

HIGHLIGHTS OF PRESCRIBING INFORMATION

These highlights do not include all the information needed to use ADVAIR DISKUS safely and effectively. See full prescribing information for ADVAIR DISKUS.

ADVAIR DISKUS (fluticasone propionate and salmeterol inhalation powder), for oral inhalation use
Initial U.S. Approval: 2000

RECENT MAJOR CHANGES

Warnings and Precautions, Glaucoma and Cataracts 1/2019 (5.15)

INDICATIONS AND USAGE

ADVAIR DISKUS is a combination product containing a corticosteroid and a long-acting beta₂-adrenergic agonist (LABA) indicated for:

- Twice-daily treatment of asthma in patients aged 4 years and older. (1.1)
- Maintenance treatment of airflow obstruction and reducing exacerbations in patients with chronic obstructive pulmonary disease (COPD). (1.2)

Important limitation of use: Not indicated for relief of acute bronchospasm. (1.1, 1.2)

DOSAGE AND ADMINISTRATION

- For oral inhalation only. (2)
- Treatment of asthma in patients aged 12 years and older: 1 inhalation of ADVAIR DISKUS 100/50, ADVAIR DISKUS 250/50, or ADVAIR DISKUS 500/50 twice daily. Starting dosage is based on asthma severity. (2.1)
- Treatment of asthma in patients aged 4 to 11 years: 1 inhalation of ADVAIR DISKUS 100/50 twice daily. (2.1)
- Maintenance treatment of COPD: 1 inhalation of ADVAIR DISKUS 250/50 twice daily. (2.2)

DOSAGE FORMS AND STRENGTHS

Inhalation powder: Inhaler containing a combination of fluticasone propionate (100, 250, or 500 mcg) and salmeterol (50 mcg) as a powder formulation for oral inhalation. (3)

CONTRAINDICATIONS

- Primary treatment of status asthmaticus or acute episodes of asthma or COPD requiring intensive measures. (4)
- Severe hypersensitivity to milk proteins or demonstrated hypersensitivity to fluticasone propionate, salmeterol, or any of the excipients. (4)

WARNINGS AND PRECAUTIONS

- LABA monotherapy increases the risk of serious asthma-related events. (5.1)
- Do not initiate in acutely deteriorating asthma or COPD. Do not use to treat acute symptoms. (5.2)
- Do not use in combination with an additional medicine containing a LABA because of risk of overdose. (5.3)
- *Candida albicans* infection of the mouth and pharynx may occur. Monitor patients periodically. Advise the patient to rinse his/her mouth with water without swallowing after inhalation to help reduce the risk. (5.4)
- Increased risk of pneumonia in patients with COPD. Monitor patients for signs and symptoms of pneumonia. (5.5)

- Potential worsening of infections (e.g., existing tuberculosis; fungal, bacterial, viral, or parasitic infections; ocular herpes simplex). Use with caution in patients with these infections. More serious or even fatal course of chickenpox or measles can occur in susceptible patients. (5.6)
- Risk of impaired adrenal function when transferring from systemic corticosteroids. Taper patients slowly from systemic corticosteroids if transferring to ADVAIR DISKUS. (5.7)
- Hypercorticism and adrenal suppression may occur with very high dosages or at the regular dosage in susceptible individuals. If such changes occur, discontinue ADVAIR DISKUS slowly. (5.8)
- If paradoxical bronchospasm occurs, discontinue ADVAIR DISKUS and institute alternative therapy. (5.10)
- Use with caution in patients with cardiovascular or central nervous system disorders because of beta-adrenergic stimulation. (5.12)
- Assess for decrease in bone mineral density initially and periodically thereafter. (5.13)
- Monitor growth of pediatric patients. (5.14)
- Glaucoma and cataracts may occur with long-term use of inhaled corticosteroids. Consider referral to an ophthalmologist in patients who develop ocular symptoms or use ADVAIR DISKUS long term. (5.15)
- Be alert to eosinophilic conditions, hypokalemia, and hyperglycemia. (5.16, 5.18)
- Use with caution in patients with convulsive disorders, thyrotoxicosis, diabetes mellitus, and ketoacidosis. (5.17)

ADVERSE REACTIONS

Most common adverse reactions (incidence ≥3%) include:

- Asthma: Upper respiratory tract infection or inflammation, pharyngitis, dysphonia, oral candidiasis, bronchitis, cough, headaches, nausea and vomiting. (6.1)
- COPD: Pneumonia, oral candidiasis, throat irritation, dysphonia, viral respiratory infections, headaches, musculoskeletal pain. (6.2)

To report SUSPECTED ADVERSE REACTIONS, contact GlaxoSmithKline at 1-888-825-5249 or FDA at 1-800-FDA-1088 or www.fda.gov/medwatch.

DRUG INTERACTIONS

- Strong cytochrome P450 3A4 inhibitors (e.g., ritonavir, ketoconazole): Use not recommended. May increase risk of systemic corticosteroid and cardiovascular effects. (7.1)
- Monoamine oxidase inhibitors and tricyclic antidepressants: Use with extreme caution. May potentiate effect of salmeterol on vascular system. (7.2)
- Beta-blockers: Use with caution. May block bronchodilatory effects of beta-agonists and produce severe bronchospasm. (7.3)
- Diuretics: Use with caution. Electrocardiographic changes and/or hypokalemia associated with non-potassium-sparing diuretics may worsen with concomitant beta-agonists. (7.4)

USE IN SPECIFIC POPULATIONS

Hepatic impairment: Monitor patients for signs of increased drug exposure. (8.6)

See 17 for PATIENT COUNSELING INFORMATION and FDA-approved patient labeling.

Revised: 1/2019

FULL PRESCRIBING INFORMATION: CONTENTS*

1 INDICATIONS AND USAGE

- 1.1 Treatment of Asthma
- 1.2 Maintenance Treatment of Chronic Obstructive Pulmonary Disease

2 DOSAGE AND ADMINISTRATION

- 2.1 Asthma
- 2.2 Chronic Obstructive Pulmonary Disease

3 DOSAGE FORMS AND STRENGTHS

4 CONTRAINDICATIONS

5 WARNINGS AND PRECAUTIONS

- 5.1 Serious Asthma-Related Events – Hospitalizations, Intubations, Death
- 5.2 Deterioration of Disease and Acute Episodes
- 5.3 Excessive Use of ADVAIR DISKUS and Use with Other Long-acting Beta₂-agonists
- 5.4 Local Effects of Inhaled Corticosteroids
- 5.5 Pneumonia

- 5.6 Immunosuppression
- 5.7 Transferring Patients from Systemic Corticosteroid Therapy
- 5.8 Hypercorticism and Adrenal Suppression
- 5.9 Drug Interactions with Strong Cytochrome P450 3A4 Inhibitors
- 5.10 Paradoxical Bronchospasm and Upper Airway Symptoms
- 5.11 Immediate Hypersensitivity Reactions
- 5.12 Cardiovascular and Central Nervous System Effects
- 5.13 Reduction in Bone Mineral Density
- 5.14 Effect on Growth
- 5.15 Glaucoma and Cataracts
- 5.16 Eosinophilic Conditions and Churg-Strauss Syndrome
- 5.17 Coexisting Conditions
- 5.18 Hypokalemia and Hyperglycemia
- 6 ADVERSE REACTIONS
- 6.1 Clinical Trials Experience in Asthma

- 6.2 Clinical Trials Experience in Chronic Obstructive Pulmonary Disease
- 6.3 Postmarketing Experience
- 7 DRUG INTERACTIONS**
- 7.1 Inhibitors of Cytochrome P450 3A4
- 7.2 Monoamine Oxidase Inhibitors and Tricyclic Antidepressants
- 7.3 Beta-adrenergic Receptor Blocking Agents
- 7.4 Non-Potassium-Sparing Diuretics
- 8 USE IN SPECIFIC POPULATIONS**
- 8.1 Pregnancy
- 8.2 Lactation
- 8.4 Pediatric Use
- 8.5 Geriatric Use
- 8.6 Hepatic Impairment
- 8.7 Renal Impairment
- 10 OVERDOSAGE**
- 10.1 Fluticasone Propionate

- 10.2 Salmeterol
- 11 DESCRIPTION**
- 12 CLINICAL PHARMACOLOGY**
- 12.1 Mechanism of Action
- 12.2 Pharmacodynamics
- 12.3 Pharmacokinetics
- 13 NONCLINICAL TOXICOLOGY**
- 13.1 Carcinogenesis, Mutagenesis, Impairment of Fertility
- 13.2 Animal Toxicology and/or Pharmacology
- 14 CLINICAL STUDIES**
- 14.1 Asthma
- 14.2 Chronic Obstructive Pulmonary Disease
- 16 HOW SUPPLIED/STORAGE AND HANDLING**
- 17 PATIENT COUNSELING INFORMATION**
- *Sections or subsections omitted from the full prescribing information are not listed.

FULL PRESCRIBING INFORMATION

1 INDICATIONS AND USAGE

1.1 Treatment of Asthma

ADVAIR DISKUS is indicated for the twice-daily treatment of asthma in patients aged 4 years and older. ADVAIR DISKUS should be used for patients not adequately controlled on a long-term asthma control medication such as an inhaled corticosteroid (ICS) or whose disease warrants initiation of treatment with both an ICS and long-acting beta₂-adrenergic agonist (LABA).

Important Limitation of Use

ADVAIR DISKUS is NOT indicated for the relief of acute bronchospasm.

1.2 Maintenance Treatment of Chronic Obstructive Pulmonary Disease

ADVAIR DISKUS 250/50 is indicated for the twice-daily maintenance treatment of airflow obstruction in patients with chronic obstructive pulmonary disease (COPD), including chronic bronchitis and/or emphysema. ADVAIR DISKUS 250/50 is also indicated to reduce exacerbations of COPD in patients with a history of exacerbations. ADVAIR DISKUS 250/50 twice daily is the only approved dosage for the treatment of COPD because an efficacy advantage of the higher strength ADVAIR DISKUS 500/50 over ADVAIR DISKUS 250/50 has not been demonstrated.

Important Limitation of Use

ADVAIR DISKUS is NOT indicated for the relief of acute bronchospasm.

2 DOSAGE AND ADMINISTRATION

ADVAIR DISKUS should be administered as 1 inhalation twice daily by the orally inhaled route only. After inhalation, the patient should rinse his/her mouth with water without swallowing to help reduce the risk of oropharyngeal candidiasis.

More frequent administration or a greater number of inhalations (more than 1 inhalation twice daily) of the prescribed strength of ADVAIR DISKUS is not recommended as some patients are

more likely to experience adverse effects with higher doses of salmeterol. Patients using ADVAIR DISKUS should not use additional LABA for any reason. [See Warnings and Precautions (5.3, 5.12).]

2.1 Asthma

If asthma symptoms arise in the period between doses, an inhaled, short-acting beta₂-agonist should be taken for immediate relief.

Adult and Adolescent Patients Aged 12 Years and Older

For patients aged 12 years and older, the dosage is 1 inhalation twice daily, approximately 12 hours apart.

When choosing the starting dosage strength of ADVAIR DISKUS, consider the patients' disease severity, based on their previous asthma therapy, including the ICS dosage, as well as the patients' current control of asthma symptoms and risk of future exacerbation.

The maximum recommended dosage is ADVAIR DISKUS 500/50 twice daily.

Improvement in asthma control following inhaled administration of ADVAIR DISKUS can occur within 30 minutes of beginning treatment, although maximum benefit may not be achieved for 1 week or longer after starting treatment. Individual patients will experience a variable time to onset and degree of symptom relief.

For patients who do not respond adequately to the starting dosage after 2 weeks of therapy, replacing the current strength of ADVAIR DISKUS with a higher strength may provide additional improvement in asthma control.

If a previously effective dosage regimen fails to provide adequate improvement in asthma control, the therapeutic regimen should be reevaluated and additional therapeutic options (e.g., replacing the current strength of ADVAIR DISKUS with a higher strength, adding additional ICS, initiating oral corticosteroids) should be considered.

Pediatric Patients Aged 4 to 11 Years

For patients with asthma aged 4 to 11 years who are not controlled on an ICS, the dosage is 1 inhalation of ADVAIR DISKUS 100/50 twice daily, approximately 12 hours apart.

2.2 Chronic Obstructive Pulmonary Disease

The recommended dosage for patients with COPD is 1 inhalation of ADVAIR DISKUS 250/50 twice daily, approximately 12 hours apart.

If shortness of breath occurs in the period between doses, an inhaled, short-acting beta₂-agonist should be taken for immediate relief.

3 DOSAGE FORMS AND STRENGTHS

Inhalation powder: Inhaler containing a foil blister strip of powder formulation for oral inhalation. The strip contains a combination of fluticasone propionate 100, 250, or 500 mcg and salmeterol 50 mcg per blister.

4 CONTRAINDICATIONS

The use of ADVAIR DISKUS is contraindicated in the following conditions:

- Primary treatment of status asthmaticus or other acute episodes of asthma or COPD where intensive measures are required [see *Warnings and Precautions (5.2)*].
- Severe hypersensitivity to milk proteins or demonstrated hypersensitivity to fluticasone propionate, salmeterol, or any of the excipients [see *Warnings and Precautions (5.11)*, *Adverse Reactions (6.3)*, *Description (11)*].

5 WARNINGS AND PRECAUTIONS

5.1 Serious Asthma-Related Events – Hospitalizations, Intubations, Death

Use of LABA as monotherapy (without ICS) for asthma is associated with an increased risk of asthma-related death [see *Salmeterol Multicenter Asthma Research Trial (SMART)*]. Available data from controlled clinical trials also suggest that use of LABA as monotherapy increases the risk of asthma-related hospitalization in pediatric and adolescent patients. These findings are considered a class effect of LABA monotherapy. When LABA are used in fixed-dose combination with ICS, data from large clinical trials do not show a significant increase in the risk of serious asthma-related events (hospitalizations, intubations, death) compared with ICS alone (see *Serious Asthma-Related Events with Inhaled Corticosteroid/Long-acting Beta₂-adrenergic Agonists*).

Serious Asthma-Related Events with Inhaled Corticosteroid/Long-acting Beta₂-adrenergic Agonists

Four (4) large, 26-week, randomized, double-blind, active-controlled clinical safety trials were conducted to evaluate the risk of serious asthma-related events when LABA were used in fixed-dose combination with ICS compared with ICS alone in subjects with asthma. Three (3) trials included adult and adolescent subjects aged 12 years and older: 1 trial compared fluticasone propionate/salmeterol inhalation powder (ADVAIR DISKUS) with fluticasone propionate inhalation powder [see *Clinical Studies (14.1)*], 1 trial compared mometasone furoate/formoterol with mometasone furoate, and 1 trial compared budesonide/formoterol with budesonide. The fourth trial included pediatric subjects aged 4 to 11 years and compared fluticasone propionate/salmeterol inhalation powder with fluticasone propionate inhalation powder [see *Clinical Studies (14.1)*]. The primary safety endpoint for all 4 trials was serious asthma-related events (hospitalizations, intubations, death). A blinded adjudication committee determined whether events were asthma related.

The 3 adult and adolescent trials were designed to rule out a risk margin of 2.0, and the pediatric trial was designed to rule out a risk margin of 2.7. Each individual trial met its pre-specified objective and demonstrated non-inferiority of ICS/LABA to ICS alone. A meta-analysis of the 3 adult and adolescent trials did not show a significant increase in risk of a serious asthma-related event with ICS/LABA fixed-dose combination compared with ICS alone (Table 1). These trials were not designed to rule out all risk for serious asthma-related events with ICS/LABA compared with ICS.

Table 1. Meta-analysis of Serious Asthma-Related Events in Subjects with Asthma Aged 12 Years and Older

	ICS/LABA (n = 17,537)^a	ICS (n = 17,552)^a	ICS/LABA vs. ICS Hazard Ratio (95% CI)^b
Serious asthma-related event ^c	116	105	1.10 (0.85, 1.44)
Asthma-related death	2	0	
Asthma-related intubation (endotracheal)	1	2	
Asthma-related hospitalization (≥24-hour stay)	115	105	

ICS = Inhaled Corticosteroid, LABA = Long-acting Beta₂-adrenergic Agonist.

^a Randomized subjects who had taken at least 1 dose of study drug. Planned treatment used for analysis.

^b Estimated using a Cox proportional hazards model for time to first event with baseline hazards stratified by each of the 3 trials.

^c Number of subjects with event that occurred within 6 months after the first use of study drug or 7 days after the last date of study drug, whichever date was later. Subjects can have one or more events, but only the first event was counted for analysis. A single, blinded, independent adjudication committee determined whether events were asthma related.

The pediatric safety trial included 6,208 pediatric subjects aged 4 to 11 years who received ICS/LABA (fluticasone propionate/salmeterol inhalation powder) or ICS (fluticasone propionate inhalation powder). In this trial, 27/3,107 (0.9%) subjects randomized to ICS/LABA and 21/3,101 (0.7%) subjects randomized to ICS experienced a serious asthma-related event. There were no asthma-related deaths or intubations. ICS/LABA did not show a significantly increased risk of a serious asthma-related event compared with ICS based on the pre-specified risk margin (2.7), with an estimated hazard ratio of time to first event of 1.29 (95% CI: 0.73, 2.27).

Salmeterol Multicenter Asthma Research Trial (SMART)

A 28-week, placebo-controlled, U.S. trial that compared the safety of salmeterol with placebo, each added to usual asthma therapy, showed an increase in asthma-related deaths in subjects receiving salmeterol (13/13,176 in subjects treated with salmeterol versus 3/13,179 in subjects

treated with placebo; relative risk: 4.37 [95% CI: 1.25, 15.34]). Use of background ICS was not required in SMART. The increased risk of asthma-related death is considered a class effect of LABA monotherapy.

5.2 Deterioration of Disease and Acute Episodes

ADVAIR DISKUS should not be initiated in patients during rapidly deteriorating or potentially life-threatening episodes of asthma or COPD. ADVAIR DISKUS has not been studied in subjects with acutely deteriorating asthma or COPD. The initiation of ADVAIR DISKUS in this setting is not appropriate.

Serious acute respiratory events, including fatalities, have been reported when salmeterol, a component of ADVAIR DISKUS, has been initiated in patients with significantly worsening or acutely deteriorating asthma. In most cases, these have occurred in patients with severe asthma (e.g., patients with a history of corticosteroid dependence, low pulmonary function, intubation, mechanical ventilation, frequent hospitalizations, previous life-threatening acute asthma exacerbations) and in some patients with acutely deteriorating asthma (e.g., patients with significantly increasing symptoms; increasing need for inhaled, short-acting beta₂-agonists; decreasing response to usual medications; increasing need for systemic corticosteroids; recent emergency room visits; deteriorating lung function). However, these events have occurred in a few patients with less severe asthma as well. It was not possible from these reports to determine whether salmeterol contributed to these events.

Increasing use of inhaled, short-acting beta₂-agonists is a marker of deteriorating asthma. In this situation, the patient requires immediate reevaluation with reassessment of the treatment regimen, giving special consideration to the possible need for replacing the current strength of ADVAIR DISKUS with a higher strength, adding additional ICS, or initiating systemic corticosteroids. Patients should not use more than 1 inhalation twice daily of ADVAIR DISKUS.

ADVAIR DISKUS should not be used for the relief of acute symptoms, i.e., as rescue therapy for the treatment of acute episodes of bronchospasm. ADVAIR DISKUS has not been studied in the relief of acute symptoms and extra doses should not be used for that purpose. Acute symptoms should be treated with an inhaled, short-acting beta₂-agonist.

When beginning treatment with ADVAIR DISKUS, patients who have been taking oral or inhaled, short-acting beta₂-agonists on a regular basis (e.g., 4 times a day) should be instructed to discontinue the regular use of these drugs.

5.3 Excessive Use of ADVAIR DISKUS and Use with Other Long-acting Beta₂-agonists

ADVAIR DISKUS should not be used more often than recommended, at higher doses than recommended, or in conjunction with other medicines containing LABA, as an overdose may result. Clinically significant cardiovascular effects and fatalities have been reported in association with excessive use of inhaled sympathomimetic drugs. Patients using ADVAIR

DISKUS should not use another medicine containing a LABA (e.g., salmeterol, formoterol fumarate, arformoterol tartrate, indacaterol) for any reason.

5.4 Local Effects of Inhaled Corticosteroids

In clinical trials, the development of localized infections of the mouth and pharynx with *Candida albicans* has occurred in subjects treated with ADVAIR DISKUS. When such an infection develops, it should be treated with appropriate local or systemic (i.e., oral) antifungal therapy while treatment with ADVAIR DISKUS continues, but at times therapy with ADVAIR DISKUS may need to be interrupted. Advise the patient to rinse his/her mouth with water without swallowing following inhalation to help reduce the risk of oropharyngeal candidiasis.

5.5 Pneumonia

Physicians should remain vigilant for the possible development of pneumonia in patients with COPD as the clinical features of pneumonia and exacerbations frequently overlap.

Lower respiratory tract infections, including pneumonia, have been reported in patients with COPD following the inhaled administration of corticosteroids, including fluticasone propionate and ADVAIR DISKUS. In 2 replicate 1-year trials in 1,579 subjects with COPD, there was a higher incidence of pneumonia reported in subjects receiving ADVAIR DISKUS 250/50 (7%) than in those receiving salmeterol 50 mcg (3%). The incidence of pneumonia in the subjects treated with ADVAIR DISKUS was higher in subjects older than 65 years (9%) compared with the incidence in subjects younger than 65 years (4%). [See *Adverse Reactions* (6.2), *Use in Specific Populations* (8.5).]

In a 3-year trial in 6,184 subjects with COPD, there was a higher incidence of pneumonia reported in subjects receiving ADVAIR DISKUS 500/50 compared with placebo (16% with ADVAIR DISKUS 500/50, 14% with fluticasone propionate 500 mcg, 11% with salmeterol 50 mcg, and 9% with placebo). Similar to what was seen in the 1-year trials with ADVAIR DISKUS 250/50, the incidence of pneumonia was higher in subjects older than 65 years (18% with ADVAIR DISKUS 500/50 versus 10% with placebo) compared with subjects younger than 65 years (14% with ADVAIR DISKUS 500/50 versus 8% with placebo). [See *Adverse Reactions* (6.2), *Use in Specific Populations* (8.5).]

5.6 Immunosuppression

Persons who are using drugs that suppress the immune system are more susceptible to infections than healthy individuals. Chickenpox and measles, for example, can have a more serious or even fatal course in susceptible children or adults using corticosteroids. In such children or adults who have not had these diseases or been properly immunized, particular care should be taken to avoid exposure. How the dose, route, and duration of corticosteroid administration affect the risk of developing a disseminated infection is not known. The contribution of the underlying disease and/or prior corticosteroid treatment to the risk is also not known. If a patient is exposed to chickenpox, prophylaxis with varicella zoster immune globulin (VZIG) may be indicated. If a

patient is exposed to measles, prophylaxis with pooled intramuscular immunoglobulin (IG) may be indicated. (See the respective package inserts for complete VZIG and IG prescribing information.) If chickenpox develops, treatment with antiviral agents may be considered.

ICS should be used with caution, if at all, in patients with active or quiescent tuberculosis infections of the respiratory tract; systemic fungal, bacterial, viral, or parasitic infections; or ocular herpes simplex.

5.7 Transferring Patients from Systemic Corticosteroid Therapy

Particular care is needed for patients who have been transferred from systemically active corticosteroids to ICS because deaths due to adrenal insufficiency have occurred in patients with asthma during and after transfer from systemic corticosteroids to less systemically available ICS. After withdrawal from systemic corticosteroids, a number of months are required for recovery of hypothalamic-pituitary-adrenal (HPA) function.

Patients who have been previously maintained on 20 mg or more of prednisone (or its equivalent) may be most susceptible, particularly when their systemic corticosteroids have been almost completely withdrawn. During this period of HPA suppression, patients may exhibit signs and symptoms of adrenal insufficiency when exposed to trauma, surgery, or infection (particularly gastroenteritis) or other conditions associated with severe electrolyte loss. Although ADVAIR DISKUS may control asthma symptoms during these episodes, in recommended doses it supplies less than normal physiological amounts of glucocorticoid systemically and does NOT provide the mineralocorticoid activity that is necessary for coping with these emergencies.

During periods of stress or a severe asthma attack, patients who have been withdrawn from systemic corticosteroids should be instructed to resume oral corticosteroids (in large doses) immediately and to contact their physicians for further instruction. These patients should also be instructed to carry a warning card indicating that they may need supplementary systemic corticosteroids during periods of stress or a severe asthma attack.

Patients requiring oral corticosteroids should be weaned slowly from systemic corticosteroid use after transferring to ADVAIR DISKUS. Prednisone reduction can be accomplished by reducing the daily prednisone dose by 2.5 mg on a weekly basis during therapy with ADVAIR DISKUS. Lung function (mean forced expiratory volume in 1 second [FEV₁] or morning peak expiratory flow [AM PEF]), beta-agonist use, and asthma symptoms should be carefully monitored during withdrawal of oral corticosteroids. In addition, patients should be observed for signs and symptoms of adrenal insufficiency, such as fatigue, lassitude, weakness, nausea and vomiting, and hypotension.

Transfer of patients from systemic corticosteroid therapy to ADVAIR DISKUS may unmask allergic conditions previously suppressed by the systemic corticosteroid therapy (e.g., rhinitis, conjunctivitis, eczema, arthritis, eosinophilic conditions).

During withdrawal from oral corticosteroids, some patients may experience symptoms of systemically active corticosteroid withdrawal (e.g., joint and/or muscular pain, lassitude, depression) despite maintenance or even improvement of respiratory function.

5.8 Hypercorticism and Adrenal Suppression

Fluticasone propionate, a component of ADVAIR DISKUS, will often help control asthma symptoms with less suppression of HPA function than therapeutically equivalent oral doses of prednisone. Since fluticasone propionate is absorbed into the circulation and can be systemically active at higher doses, the beneficial effects of ADVAIR DISKUS in minimizing HPA dysfunction may be expected only when recommended dosages are not exceeded and individual patients are titrated to the lowest effective dose. A relationship between plasma levels of fluticasone propionate and inhibitory effects on stimulated cortisol production has been shown after 4 weeks of treatment with fluticasone propionate inhalation aerosol. Since individual sensitivity to effects on cortisol production exists, physicians should consider this information when prescribing ADVAIR DISKUS.

Because of the possibility of significant systemic absorption of ICS in sensitive patients, patients treated with ADVAIR DISKUS should be observed carefully for any evidence of systemic corticosteroid effects. Particular care should be taken in observing patients postoperatively or during periods of stress for evidence of inadequate adrenal response.

It is possible that systemic corticosteroid effects such as hypercorticism and adrenal suppression (including adrenal crisis) may appear in a small number of patients who are sensitive to these effects. If such effects occur, ADVAIR DISKUS should be reduced slowly, consistent with accepted procedures for reducing systemic corticosteroids, and other treatments for management of asthma symptoms should be considered.

5.9 Drug Interactions with Strong Cytochrome P450 3A4 Inhibitors

The use of strong cytochrome P450 3A4 (CYP3A4) inhibitors (e.g., ritonavir, atazanavir, clarithromycin, indinavir, itraconazole, nefazodone, nelfinavir, saquinavir, ketoconazole, telithromycin) with ADVAIR DISKUS is not recommended because increased systemic corticosteroid and increased cardiovascular adverse effects may occur [*see Drug Interactions (7.1), Clinical Pharmacology (12.3)*].

5.10 Paradoxical Bronchospasm and Upper Airway Symptoms

As with other inhaled medicines, ADVAIR DISKUS can produce paradoxical bronchospasm, which may be life threatening. If paradoxical bronchospasm occurs following dosing with ADVAIR DISKUS, it should be treated immediately with an inhaled, short-acting bronchodilator; ADVAIR DISKUS should be discontinued immediately; and alternative therapy should be instituted. Upper airway symptoms of laryngeal spasm, irritation, or swelling, such as stridor and choking, have been reported in patients receiving ADVAIR DISKUS.

5.11 Immediate Hypersensitivity Reactions

Immediate hypersensitivity reactions (e.g., urticaria, angioedema, rash, bronchospasm, hypotension), including anaphylaxis, may occur after administration of ADVAIR DISKUS. There have been reports of anaphylactic reactions in patients with severe milk protein allergy after inhalation of powder products containing lactose; therefore, patients with severe milk protein allergy should not use ADVAIR DISKUS [*see Contraindications (4)*].

5.12 Cardiovascular and Central Nervous System Effects

Excessive beta-adrenergic stimulation has been associated with seizures, angina, hypertension or hypotension, tachycardia with rates up to 200 beats/min, arrhythmias, nervousness, headache, tremor, palpitation, nausea, dizziness, fatigue, malaise, and insomnia [*see Overdosage (10.2)*]. Therefore, ADVAIR DISKUS, like all products containing sympathomimetic amines, should be used with caution in patients with cardiovascular disorders, especially coronary insufficiency, cardiac arrhythmias, and hypertension.

Salmeterol, a component of ADVAIR DISKUS, can produce a clinically significant cardiovascular effect in some patients as measured by pulse rate, blood pressure, and/or symptoms. Although such effects are uncommon after administration of salmeterol at recommended doses, if they occur, the drug may need to be discontinued. In addition, beta-agonists have been reported to produce electrocardiogram (ECG) changes, such as flattening of the T wave, prolongation of the QTc interval, and ST segment depression. The clinical significance of these findings is unknown. Large doses of inhaled or oral salmeterol (12 to 20 times the recommended dose) have been associated with clinically significant prolongation of the QTc interval, which has the potential for producing ventricular arrhythmias. Fatalities have been reported in association with excessive use of inhaled sympathomimetic drugs.

5.13 Reduction in Bone Mineral Density

Decreases in bone mineral density (BMD) have been observed with long-term administration of products containing ICS. The clinical significance of small changes in BMD with regard to long-term consequences such as fracture is unknown. Patients with major risk factors for decreased bone mineral content, such as prolonged immobilization, family history of osteoporosis, postmenopausal status, tobacco use, advanced age, poor nutrition, or chronic use of drugs that can reduce bone mass (e.g., anticonvulsants, oral corticosteroids), should be monitored and treated with established standards of care. Since patients with COPD often have multiple risk factors for reduced BMD, assessment of BMD is recommended prior to initiating ADVAIR DISKUS and periodically thereafter. If significant reductions in BMD are seen and ADVAIR DISKUS is still considered medically important for that patient's COPD therapy, use of medicine to treat or prevent osteoporosis should be strongly considered.

2-Year Fluticasone Propionate Trial

A 2-year trial in 160 subjects (females aged 18 to 40 years, males 18 to 50) with asthma receiving chlorofluorocarbon (CFC)-propelled fluticasone propionate inhalation aerosol 88 or 440 mcg twice daily demonstrated no statistically significant changes in BMD at any time point (24, 52, 76, and 104 weeks of double-blind treatment) as assessed by dual-energy x-ray absorptiometry at lumbar regions L1 through L4.

3-Year Bone Mineral Density Trial

Effects of treatment with ADVAIR DISKUS 250/50 or salmeterol 50 mcg on BMD at the L₁-L₄ lumbar spine and total hip were evaluated in 186 subjects with COPD (aged 43 to 87 years) in a 3-year double-blind trial. Of those enrolled, 108 subjects (72 males and 36 females) were followed for the entire 3 years. BMD evaluations were conducted at baseline and at 6-month intervals. Conclusions cannot be drawn from this trial regarding BMD decline in subjects treated with ADVAIR DISKUS versus salmeterol due to the inconsistency of treatment differences across gender and between lumbar spine and total hip.

In this trial there were 7 non-traumatic fractures reported in 5 subjects treated with ADVAIR DISKUS and 1 non-traumatic fracture in 1 subject treated with salmeterol. None of the non-traumatic fractures occurred in the vertebrae, hip, or long bones.

3-Year Survival Trial

Effects of treatment with ADVAIR DISKUS 500/50, fluticasone propionate 500 mcg, salmeterol 50 mcg, or placebo on BMD was evaluated in a subset of 658 subjects (females and males aged 40 to 80 years) with COPD in the 3-year survival trial. BMD evaluations were conducted at baseline and at 48, 108, and 158 weeks. Conclusions cannot be drawn from this trial because of the large number of dropouts (>50%) before the end of the follow-up and the maldistribution of covariates among the treatment groups that can affect BMD.

Fracture risk was estimated for the entire population of subjects with COPD in the survival trial (N = 6,184). The probability of a fracture over 3 years was 6.3% for ADVAIR DISKUS, 5.4% for fluticasone propionate, 5.1% for salmeterol, and 5.1% for placebo.

5.14 Effect on Growth

Orally inhaled corticosteroids may cause a reduction in growth velocity when administered to pediatric patients. Monitor the growth of pediatric patients receiving ADVAIR DISKUS routinely (e.g., via stadiometry). To minimize the systemic effects of orally inhaled corticosteroids, including ADVAIR DISKUS, titrate each patient's dosage to the lowest dosage that effectively controls his/her symptoms [*see Dosage and Administration (2.1), Use in Specific Populations (8.4)*].

5.15 Glaucoma and Cataracts

Glaucoma, increased intraocular pressure, and cataracts have been reported in patients with asthma and COPD following the long-term administration of ICS, including fluticasone propionate, a component of ADVAIR DISKUS. Consider referral to an ophthalmologist in patients who develop ocular symptoms or use ADVAIR DISKUS long term.

Effects of treatment with ADVAIR DISKUS 500/50, fluticasone propionate 500 mcg, salmeterol 50 mcg, or placebo on development of cataracts or glaucoma was evaluated in a subset of 658 subjects with COPD in the 3-year survival trial. Ophthalmic examinations were conducted at baseline and at 48, 108, and 158 weeks. Conclusions about cataracts cannot be drawn from this trial because the high incidence of cataracts at baseline (61% to 71%) resulted in an inadequate number of subjects treated with ADVAIR DISKUS 500/50 who were eligible and available for evaluation of cataracts at the end of the trial (n = 53). The incidence of newly diagnosed glaucoma was 2% with ADVAIR DISKUS 500/50, 5% with fluticasone propionate, 0% with salmeterol, and 2% with placebo.

5.16 Eosinophilic Conditions and Churg-Strauss Syndrome

In rare cases, patients on inhaled fluticasone propionate, a component of ADVAIR DISKUS, may present with systemic eosinophilic conditions. Some of these patients have clinical features of vasculitis consistent with Churg-Strauss syndrome, a condition that is often treated with systemic corticosteroid therapy. These events usually, but not always, have been associated with the reduction and/or withdrawal of oral corticosteroid therapy following the introduction of fluticasone propionate. Cases of serious eosinophilic conditions have also been reported with other ICS in this clinical setting. Physicians should be alert to eosinophilia, vasculitic rash, worsening pulmonary symptoms, cardiac complications, and/or neuropathy presenting in their patients. A causal relationship between fluticasone propionate and these underlying conditions has not been established.

5.17 Coexisting Conditions

ADVAIR DISKUS, like all medicines containing sympathomimetic amines, should be used with caution in patients with convulsive disorders or thyrotoxicosis and in those who are unusually responsive to sympathomimetic amines. Doses of the related beta₂-adrenoceptor agonist albuterol, when administered intravenously, have been reported to aggravate preexisting diabetes mellitus and ketoacidosis.

5.18 Hypokalemia and Hyperglycemia

Beta-adrenergic agonist medicines may produce significant hypokalemia in some patients, possibly through intracellular shunting, which has the potential to produce adverse cardiovascular effects [see *Clinical Pharmacology (12.2)*]. The decrease in serum potassium is usually transient, not requiring supplementation. Clinically significant changes in blood glucose

and/or serum potassium were seen infrequently during clinical trials with ADVAIR DISKUS at recommended doses.

6 ADVERSE REACTIONS

Use of LABA may result in the following:

- Serious asthma-related events – hospitalizations, intubations, death [*see Warnings and Precautions (5.1)*]
- Cardiovascular and central nervous system effects [*see Warnings and Precautions (5.12)*]

Systemic and local corticosteroid use may result in the following:

- *Candida albicans* infection [*see Warnings and Precautions (5.4)*]
- Pneumonia in patients with COPD [*see Warnings and Precautions (5.5)*]
- Immunosuppression [*see Warnings and Precautions (5.6)*]
- Hypercorticism and adrenal suppression [*see Warnings and Precautions (5.8)*]
- Reduction in bone mineral density [*see Warnings and Precautions (5.13)*]
- Growth effects [*see Warnings and Precautions (5.14)*]
- Glaucoma and cataracts [*see Warnings and Precautions (5.15)*]

Because clinical trials are conducted under widely varying conditions, adverse reaction rates observed in the clinical trials of a drug cannot be directly compared with rates in the clinical trials of another drug and may not reflect the rates observed in practice.

6.1 Clinical Trials Experience in Asthma

Adult and Adolescent Subjects Aged 12 Years and Older

The incidence of adverse reactions associated with ADVAIR DISKUS in Table 2 is based upon two 12-week, placebo-controlled, U.S. clinical trials (Trials 1 and 2). A total of 705 adult and adolescent subjects (349 females and 356 males) previously treated with salmeterol or ICS were treated twice daily with ADVAIR DISKUS (100/50- or 250/50-mcg doses), fluticasone propionate inhalation powder (100- or 250-mcg doses), salmeterol inhalation powder 50 mcg, or placebo. The average duration of exposure was 60 to 79 days in the active treatment groups compared with 42 days in the placebo group.

Table 2. Adverse Reactions with ADVAIR DISKUS with $\geq 3\%$ Incidence and More Common than Placebo in Adult and Adolescent Subjects with Asthma

Adverse Event	ADVAIR DISKUS 100/50 (n = 92) %	ADVAIR DISKUS 250/50 (n = 84) %	Fluticasone Propionate 100 mcg (n = 90) %	Fluticasone Propionate 250 mcg (n = 84) %	Salmeterol 50 mcg (n = 180) %	Placebo (n = 175) %
Ear, nose, and throat						
Upper respiratory tract infection	27	21	29	25	19	14
Pharyngitis	13	10	7	12	8	6
Upper respiratory inflammation	7	6	7	8	8	5
Sinusitis	4	5	6	1	3	4
Hoarseness/dysphonia	5	2	2	4	<1	<1
Oral candidiasis	1	4	2	2	0	0
Lower respiratory						
Viral respiratory infections	4	4	4	10	6	3
Bronchitis	2	8	1	2	2	2
Cough	3	6	0	0	3	2
Neurology						
Headaches	12	13	14	8	10	7
Gastrointestinal						
Nausea and vomiting	4	6	3	4	1	1
Gastrointestinal discomfort and pain	4	1	0	2	1	1
Diarrhea	4	2	2	2	1	1
Viral gastrointestinal infections	3	0	3	1	2	2
Non-site specific						
Candidiasis unspecified site	3	0	1	4	0	1
Musculoskeletal						
Musculoskeletal pain	4	2	1	5	3	3

The types of adverse reactions and events reported in Trial 3, a 28-week, non-U.S. clinical trial in 503 subjects previously treated with ICS who were treated twice daily with ADVAIR DISKUS 500/50, fluticasone propionate inhalation powder 500 mcg and salmeterol inhalation powder 50 mcg used concurrently, or fluticasone propionate inhalation powder 500 mcg, were similar to those reported in Table 2.

Additional Adverse Reactions

Other adverse reactions not previously listed, whether considered drug-related or not by the investigators, that were reported more frequently by subjects with asthma treated with ADVAIR DISKUS compared with subjects treated with placebo include the following: lymphatic signs and symptoms; muscle injuries; fractures; wounds and lacerations; contusions and hematomas; ear signs and symptoms; nasal signs and symptoms; nasal sinus disorders; keratitis and conjunctivitis; dental discomfort and pain; gastrointestinal signs and symptoms; oral ulcerations; oral discomfort and pain; lower respiratory signs and symptoms; pneumonia; muscle stiffness, tightness, and rigidity; bone and cartilage disorders; sleep disorders; compressed nerve syndromes; viral infections; pain; chest symptoms; fluid retention; bacterial infections; unusual taste; viral skin infections; skin flakiness and acquired ichthyosis; disorders of sweat and sebum.

Pediatric Subjects Aged 4 to 11 Years

The safety data for pediatric subjects aged 4 to 11 years is based upon 1 U.S. trial of 12 weeks' treatment duration. A total of 203 subjects (74 females and 129 males) who were receiving ICS at trial entry were randomized to either ADVAIR DISKUS 100/50 or fluticasone propionate inhalation powder 100 mcg twice daily. Common adverse reactions ($\geq 3\%$ and greater than placebo) seen in the pediatric subjects but not reported in the adult and adolescent clinical trials include: throat irritation and ear, nose, and throat infections.

Laboratory Test Abnormalities

Elevation of hepatic enzymes was reported in $\geq 1\%$ of subjects in clinical trials. The elevations were transient and did not lead to discontinuation from the trials. In addition, there were no clinically relevant changes noted in glucose or potassium.

6.2 Clinical Trials Experience in Chronic Obstructive Pulmonary Disease

Short-term (6 Months to 1 Year) Trials

The short-term safety data are based on exposure to ADVAIR DISKUS 250/50 twice daily in one 6-month and two 1-year clinical trials. In the 6-month trial, a total of 723 adult subjects (266 females and 457 males) were treated twice daily with ADVAIR DISKUS 250/50, fluticasone propionate inhalation powder 250 mcg, salmeterol inhalation powder, or placebo. The mean age of the subjects was 64, and the majority (93%) was Caucasian. In this trial, 70% of the subjects treated with ADVAIR DISKUS reported an adverse reaction compared with 64% on placebo. The average duration of exposure to ADVAIR DISKUS 250/50 was 141.3 days compared with 131.6 days for placebo. The incidence of adverse reactions in the 6-month trial is shown in Table 3.

Table 3. Overall Adverse Reactions with ADVAIR DISKUS 250/50 with ≥3% Incidence in Subjects with Chronic Obstructive Pulmonary Disease Associated with Chronic Bronchitis

Adverse Event	ADVAIR DISKUS 250/50 (n = 178) %	Fluticasone Propionate 250 mcg (n = 183) %	Salmeterol 50 mcg (n = 177) %	Placebo (n = 185) %
Ear, nose, and throat				
Candidiasis mouth/throat	10	6	3	1
Throat irritation	8	5	4	7
Hoarseness/dysphonia	5	3	<1	0
Sinusitis	3	8	5	3
Lower respiratory				
Viral respiratory infections	6	4	3	3
Neurology				
Headaches	16	11	10	12
Dizziness	4	<1	3	2
Non-site specific				
Fever	4	3	0	3
Malaise and fatigue	3	2	2	3
Musculoskeletal				
Musculoskeletal pain	9	8	12	9
Muscle cramps and spasms	3	3	1	1

In the two 1-year trials, ADVAIR DISKUS 250/50 was compared with salmeterol in 1,579 subjects (863 males and 716 females). The mean age of the subjects was 65 years, and the majority (94%) was Caucasian. To be enrolled, all of the subjects had to have had a COPD exacerbation in the previous 12 months. In this trial, 88% of the subjects treated with ADVAIR DISKUS and 86% of the subjects treated with salmeterol reported an adverse event. The most common events that occurred with a frequency of >5% and more frequently in the subjects treated with ADVAIR DISKUS were nasopharyngitis, upper respiratory tract infection, nasal congestion, back pain, sinusitis, dizziness, nausea, pneumonia, candidiasis, and dysphonia. Overall, 55 (7%) of the subjects treated with ADVAIR DISKUS and 25 (3%) of the subjects treated with salmeterol developed pneumonia.

The incidence of pneumonia was higher in subjects older than 65 years, 9% in the subjects treated with ADVAIR DISKUS compared with 4% in the subjects treated with ADVAIR DISKUS younger than 65 years. In the subjects treated with salmeterol, the incidence of pneumonia was the same (3%) in both age groups. [See *Warnings and Precautions (5.5)*, *Use in Specific Populations (8.5)*.]

Long-term (3 Years) Trial

The safety of ADVAIR DISKUS 500/50 was evaluated in a randomized, double-blind, placebo-controlled, multicenter, international, 3-year trial in 6,184 adult subjects with COPD (4,684 males and 1,500 females). The mean age of the subjects was 65 years, and the majority (82%) was Caucasian. The distribution of adverse events was similar to that seen in the 1-year trials with ADVAIR DISKUS 250/50. In addition, pneumonia was reported in a significantly increased number of subjects treated with ADVAIR DISKUS 500/50 and fluticasone propionate 500 mcg (16% and 14%, respectively) compared with subjects treated with salmeterol 50 mcg or placebo (11% and 9%, respectively). When adjusted for time on treatment, the rates of pneumonia were 84 and 88 events per 1,000 treatment-years in the groups treated with fluticasone propionate 500 mcg and with ADVAIR DISKUS 500/50, respectively, compared with 52 events per 1,000 treatment-years in the salmeterol and placebo groups. Similar to what was seen in the 1-year trials with ADVAIR DISKUS 250/50, the incidence of pneumonia was higher in subjects older than 65 years (18% with ADVAIR DISKUS 500/50 versus 10% with placebo) compared with subjects younger than 65 years (14% with ADVAIR DISKUS 500/50 versus 8% with placebo). [See Warnings and Precautions (5.5), Use in Specific Populations (8.5).]

Additional Adverse Reactions

Other adverse reactions not previously listed, whether considered drug-related or not by the investigators, that were reported more frequently by subjects with COPD treated with ADVAIR DISKUS compared with subjects treated with placebo include the following: syncope; ear, nose, and throat infections; ear signs and symptoms; laryngitis; nasal congestion/blockage; nasal sinus disorders; pharyngitis/throat infection; hypothyroidism; dry eyes; eye infections; gastrointestinal signs and symptoms; oral lesions; abnormal liver function tests; bacterial infections; edema and swelling; viral infections.

Laboratory Abnormalities

There were no clinically relevant changes in these trials. Specifically, no increased reporting of neutrophilia or changes in glucose or potassium was noted.

6.3 Postmarketing Experience

In addition to adverse reactions reported from clinical trials, the following adverse reactions have been identified during postapproval use of any formulation of ADVAIR, fluticasone propionate, and/or salmeterol regardless of indication. Because these reactions are reported voluntarily from a population of uncertain size, it is not always possible to reliably estimate their frequency or establish a causal relationship to drug exposure. These events have been chosen for inclusion due to either their seriousness, frequency of reporting, or causal connection to ADVAIR DISKUS, fluticasone propionate, and/or salmeterol or a combination of these factors.

Cardiac Disorders

Arrhythmias (including atrial fibrillation, extrasystoles, supraventricular tachycardia), ventricular tachycardia.

Endocrine Disorders

Cushing's syndrome, Cushingoid features, growth velocity reduction in children/adolescents, hypercorticism.

Eye Disorders

Glaucoma.

Gastrointestinal Disorders

Abdominal pain, dyspepsia, xerostomia.

Immune System Disorders

Immediate and delayed hypersensitivity reaction (including very rare anaphylactic reaction). Very rare anaphylactic reaction in patients with severe milk protein allergy.

Infections and Infestations

Esophageal candidiasis.

Metabolic and Nutrition Disorders

Hyperglycemia, weight gain.

Musculoskeletal, Connective Tissue, and Bone Disorders

Arthralgia, cramps, myositis, osteoporosis.

Nervous System Disorders

Paresthesia, restlessness.

Psychiatric Disorders

Agitation, aggression, depression. Behavioral changes, including hyperactivity and irritability, have been reported very rarely and primarily in children.

Reproductive System and Breast Disorders

Dysmenorrhea.

Respiratory, Thoracic, and Mediastinal Disorders

Chest congestion; chest tightness; dyspnea; facial and oropharyngeal edema, immediate bronchospasm; paradoxical bronchospasm; tracheitis; wheezing; reports of upper respiratory symptoms of laryngeal spasm, irritation, or swelling such as stridor or choking.

Skin and Subcutaneous Tissue Disorders

Ecchymoses, photodermatitis.

Vascular Disorders

Pallor.

7 DRUG INTERACTIONS

ADVAIR DISKUS has been used concomitantly with other drugs, including short-acting beta₂-agonists, methylxanthines, and intranasal corticosteroids, commonly used in patients with asthma or COPD without adverse drug reactions [see *Clinical Pharmacology (12.2)*]. No formal drug interaction trials have been performed with ADVAIR DISKUS.

7.1 Inhibitors of Cytochrome P450 3A4

Fluticasone propionate and salmeterol, the individual components of ADVAIR DISKUS, are substrates of CYP3A4. The use of strong CYP3A4 inhibitors (e.g., ritonavir, atazanavir, clarithromycin, indinavir, itraconazole, nefazodone, nelfinavir, saquinavir, ketoconazole, telithromycin) with ADVAIR DISKUS is not recommended because increased systemic corticosteroid and increased cardiovascular adverse effects may occur.

Ritonavir

Fluticasone Propionate: A drug interaction trial with fluticasone propionate aqueous nasal spray in healthy subjects has shown that ritonavir (a strong CYP3A4 inhibitor) can significantly increase plasma fluticasone propionate exposure, resulting in significantly reduced serum cortisol concentrations [see *Clinical Pharmacology (12.3)*]. During postmarketing use, there have been reports of clinically significant drug interactions in patients receiving fluticasone propionate and ritonavir, resulting in systemic corticosteroid effects including Cushing's syndrome and adrenal suppression.

Ketoconazole

Fluticasone Propionate: Coadministration of orally inhaled fluticasone propionate (1,000 mcg) and ketoconazole (200 mg once daily) resulted in a 1.9-fold increase in plasma fluticasone propionate exposure and a 45% decrease in plasma cortisol area under the curve (AUC), but had no effect on urinary excretion of cortisol.

Salmeterol: In a drug interaction trial in 20 healthy subjects, coadministration of inhaled salmeterol (50 mcg twice daily) and oral ketoconazole (400 mg once daily) for 7 days resulted in greater systemic exposure to salmeterol (AUC increased 16-fold and C_{max} increased 1.4-fold). Three (3) subjects were withdrawn due to beta₂-agonist side effects (2 with prolonged QTc and 1 with palpitations and sinus tachycardia). Although there was no statistical effect on the mean QTc, coadministration of salmeterol and ketoconazole was associated with more frequent increases in QTc duration compared with salmeterol and placebo administration.

7.2 Monoamine Oxidase Inhibitors and Tricyclic Antidepressants

ADVAIR DISKUS should be administered with extreme caution to patients being treated with monoamine oxidase inhibitors or tricyclic antidepressants, or within 2 weeks of discontinuation of such agents, because the action of salmeterol, a component of ADVAIR DISKUS, on the vascular system may be potentiated by these agents.

7.3 Beta-adrenergic Receptor Blocking Agents

Beta-blockers not only block the pulmonary effect of beta-agonists, such as salmeterol, a component of ADVAIR DISKUS, but may also produce severe bronchospasm in patients with asthma or COPD. Therefore, patients with asthma or COPD should not normally be treated with beta-blockers. However, under certain circumstances, there may be no acceptable alternatives to the use of beta-adrenergic blocking agents for these patients; cardioselective beta-blockers could be considered, although they should be administered with caution.

7.4 Non-Potassium-Sparing Diuretics

The ECG changes and/or hypokalemia that may result from the administration of non-potassium-sparing diuretics (such as loop or thiazide diuretics) can be acutely worsened by beta-agonists, such as salmeterol, a component of ADVAIR DISKUS, especially when the recommended dose of the beta-agonist is exceeded. Although the clinical significance of these effects is not known, caution is advised in the coadministration of ADVAIR DISKUS with non-potassium-sparing diuretics.

8 USE IN SPECIFIC POPULATIONS

8.1 Pregnancy

Risk Summary

There are insufficient data on the use of ADVAIR DISKUS or individual monoproducts, fluticasone propionate and salmeterol xinafoate, in pregnant women. There are clinical considerations with the use of ADVAIR DISKUS in pregnant women. (*See Clinical Considerations.*) In animals, teratogenicity characteristic of corticosteroids, decreased fetal body weight and/or skeletal variations, in rats, mice, and rabbits were observed with subcutaneously administered maternal toxic doses of fluticasone propionate less than the maximum recommended human daily inhaled dose (MRHDID) on a mcg/m² basis. (*See Data.*) However, fluticasone propionate administered via inhalation to rats decreased fetal body weight, but did not induce teratogenicity at a maternal toxic dose less than the MRHDID on a mcg/m² basis. (*See Data.*) Experience with oral corticosteroids suggests that rodents are more prone to teratogenic effects from corticosteroids than humans. Oral administration of salmeterol to pregnant rabbits caused teratogenicity characteristic of beta-adrenoceptor stimulation at maternal doses approximately 50 times the MRHDID on an AUC basis. These adverse effects generally occurred at large multiples of the MRHDID when salmeterol was administered by the oral route

to achieve high systemic exposures. No such effects occurred at an oral salmeterol dose approximately 20 times the MRHDID. (*See Data.*)

The estimated risk of major birth defects and miscarriage for the indicated population is unknown. In the U.S. general population, the estimated risk of major birth defects and miscarriage in clinically recognized pregnancies is 2% to 4% and 15% to 20%, respectively.

Clinical Considerations

Disease-Associated Maternal and/or Embryofetal Risk: In women with poorly or moderately controlled asthma, there is an increased risk of several perinatal outcomes such as pre-eclampsia in the mother and prematurity, low birth weight, and small for gestational age in the neonate. Pregnant women should be closely monitored and medication adjusted as necessary to maintain optimal control of asthma.

Labor and Delivery: There are no human studies evaluating the effects of ADVAIR DISKUS during labor and delivery. Because of the potential for beta-agonist interference with uterine contractility, use of ADVAIR DISKUS during labor should be restricted to those patients in whom the benefits clearly outweigh the risks.

Data

Human Data: Fluticasone Propionate: Following inhaled administration, fluticasone propionate was detected in the neonatal cord blood after delivery.

Animal Data: Fluticasone Propionate and Salmeterol: In an embryofetal development study with pregnant rats that received the combination of subcutaneous administration of fluticasone propionate and oral administration of salmeterol at doses of 0/1,000; 30/0; 10/100; 30/1,000; and 100/10,000 mcg/kg/day (as fluticasone propionate/salmeterol) during the period of organogenesis, findings were generally consistent with the individual monoproducts and there was no exacerbation of expected fetal effects. Omphalocele, increased embryofetal deaths, decreased body weight, and skeletal variations were observed in rat fetuses in the presence of maternal toxicity when combining fluticasone propionate at a dose approximately equivalent to the MRHDID (on a mcg/m² basis at a maternal subcutaneous dose of 100 mcg/kg/day) and salmeterol at a dose approximately 970 times the MRHDID (on a mcg/m² basis at a maternal oral dose of 10,000 mcg/kg/day). The rat no observed adverse effect level (NOAEL) was observed when combining fluticasone propionate at a dose approximately 0.3 times the MRHDID (on a mcg/m² basis at a maternal subcutaneous dose of 30 mcg/kg/day) and salmeterol at a dose approximately 100 times the MRHDID (on a mcg/m² basis at a maternal oral dose of 1,000 mcg/kg/day).

In an embryofetal development study with pregnant mice that received the combination of subcutaneous administration of fluticasone propionate and oral administration of salmeterol at doses of 0/1,400; 40/0; 10/200; 40/1,400; or 150/10,000 mcg/kg/day (as fluticasone propionate/salmeterol) during the period of organogenesis, findings were generally consistent

with the individual monoproducts and there was no exacerbation of expected fetal effects. Cleft palate, fetal death, increased implantation loss, and delayed ossification were observed in mouse fetuses when combining fluticasone propionate at a dose approximately 0.7 times the MRHDID (on a mcg/m² basis at a maternal subcutaneous dose of 150 mcg/kg/day) and salmeterol at a dose approximately 490 times the MRHDID (on a mcg/m² basis at a maternal oral dose of 10,000 mcg/kg/day). No developmental toxicity was observed at combination doses of fluticasone propionate up to approximately 0.2 times the MRHDID (on a mcg/m² basis at a maternal subcutaneous dose of 40 mcg/kg) and doses of salmeterol up to approximately 70 times the MRHDID (on a mcg/m² basis at a maternal oral dose of 1,400 mcg/kg).

Fluticasone Propionate: In embryofetal development studies with pregnant rats and mice dosed by the subcutaneous route throughout the period of organogenesis, fluticasone propionate was teratogenic in both species. Omphalocele, decreased body weight, and skeletal variations were observed in rat fetuses, in the presence of maternal toxicity, at a dose approximately equivalent to the MRHDID (on a mcg/m² basis with a maternal subcutaneous dose of 100 mcg/kg/day). The rat NOAEL was observed at approximately 0.3 times the MRHDID (on a mcg/m² basis with a maternal subcutaneous dose of 30 mcg/kg/day). Cleft palate and fetal skeletal variations were observed in mouse fetuses at a dose approximately 0.2 times the MRHDID (on a mcg/m² basis with a maternal subcutaneous dose of 45 mcg/kg/day). The mouse NOAEL was observed with a dose approximately 0.07 times the MRHDID (on a mcg/m² basis with a maternal subcutaneous dose of 15 mcg/kg/day).

In an embryofetal development study with pregnant rats dosed by the inhalation route throughout the period of organogenesis, fluticasone propionate produced decreased fetal body weights and skeletal variations, in the presence of maternal toxicity, at a dose approximately 0.25 times the MRHDID (on a mcg/m² basis with a maternal inhalation dose of 25.7 mcg/kg/day); however, there was no evidence of teratogenicity. The NOAEL was observed with a dose approximately 0.05 times the MRHDID (on a mcg/m² basis with a maternal inhalation dose of 5.5 mcg/kg/day).

In an embryofetal development study in pregnant rabbits that were dosed by the subcutaneous route throughout organogenesis, fluticasone propionate produced reductions of fetal body weights, in the presence of maternal toxicity, at doses approximately 0.012 times the MRHDID and higher (on a mcg/m² basis with a maternal subcutaneous dose of 0.57 mcg/kg/day). Teratogenicity was evident based upon a finding of cleft palate for 1 fetus at a dose approximately 0.08 times the MRHDID (on a mcg/m² basis with a maternal subcutaneous dose of 4 mcg/kg/day). The NOAEL was observed in rabbit fetuses with a dose approximately 0.002 times the MRHDID (on a mcg/m² basis with a maternal subcutaneous dose of 0.08 mcg/kg/day).

Fluticasone propionate crossed the placenta following subcutaneous administration to mice and rats and oral administration to rabbits.

In a pre- and post-natal development study in pregnant rats dosed by the subcutaneous route from late gestation through delivery and lactation (Gestation Day 17 to Postpartum Day 22),

fluticasone propionate was not associated with decreases in pup body weight, and had no effects on developmental landmarks, learning, memory, reflexes, or fertility at doses up to 0.5 times the MRHDID (on a mcg/m² basis with maternal subcutaneous doses up to 50 mcg/kg/day).

Salmeterol: In 3 embryofetal development studies, pregnant rabbits received oral administration of salmeterol at doses ranging from 100 to 10,000 mcg/kg/day during the period of organogenesis. In pregnant Dutch rabbits administered salmeterol doses approximately 50 times the MRHDID (on an AUC basis at maternal oral doses of 1,000 mcg/kg/day and higher), fetal toxic effects were observed characteristically resulting from beta-adrenoceptor stimulation. These included precocious eyelid openings, cleft palate, sternebral fusion, limb and paw flexures, and delayed ossification of the frontal cranial bones. No such effects occurred at a salmeterol dose approximately 20 times the MRHDID (on an AUC basis at a maternal oral dose of 600 mcg/kg/day). New Zealand White rabbits were less sensitive since only delayed ossification of the frontal cranial bones was seen at a salmeterol dose approximately 2,000 times the MRHDID (on a mcg/m² basis at a maternal oral dose of 10,000 mcg/kg/day).

In 2 embryofetal development studies, pregnant rats received salmeterol by oral administration at doses ranging from 100 to 10,000 mcg/kg/day during the period of organogenesis. Salmeterol produced no maternal toxicity or embryofetal effects at doses up to 973 times the MRHDID (on a mcg/m² basis at maternal oral doses up to 10,000 mcg/kg/day).

In a peri- and post-natal development study in pregnant rats dosed by the oral route from late gestation through delivery and lactation, salmeterol at a dose 973 times the MRHDID (on a mcg/m² basis with a maternal oral dose of 10,000 mcg/kg/day) was fetotoxic and decreased the fertility of survivors.

Salmeterol xinafoate crossed the placenta following oral administration to mice and rats.

8.2 Lactation

Risk Summary

There are no available data on the presence of fluticasone propionate or salmeterol in human milk, the effects on the breastfed child, or the effects on milk production. Other corticosteroids have been detected in human milk. However, fluticasone propionate and salmeterol concentrations in plasma after inhaled therapeutic doses are low and therefore concentrations in human breast milk are likely to be correspondingly low [see *Clinical Pharmacology (12.3)*]. The developmental and health benefits of breastfeeding should be considered along with the mother's clinical need for ADVAIR DISKUS and any potential adverse effects on the breastfed child from ADVAIR DISKUS or from the underlying maternal condition.

Data

Animal Data: Subcutaneous administration of tritiated fluticasone propionate at a dose of 10 mcg/kg/day to lactating rats resulted in measurable levels in milk. Oral administration of salmeterol at a dose of 10,000 mcg/kg/day to lactating rats resulted in measurable levels in milk.

8.4 Pediatric Use

Use of ADVAIR DISKUS 100/50 in patients aged 4 to 11 years is supported by extrapolation of efficacy data from older subjects and by safety and efficacy data from a trial of ADVAIR DISKUS 100/50 in children with asthma aged 4 to 11 years [*see Adverse Reactions (6.1), Clinical Pharmacology (12.3), Clinical Studies (14.1)*]. The safety and effectiveness of ADVAIR DISKUS in children with asthma younger than 4 years have not been established.

ICS, including fluticasone propionate, a component of ADVAIR DISKUS, may cause a reduction in growth velocity in children and adolescents [*see Warnings and Precautions (5.14)*]. The growth of pediatric patients receiving orally inhaled corticosteroids, including ADVAIR DISKUS, should be monitored.

A 52-week placebo-controlled trial to assess the potential growth effects of fluticasone propionate inhalation powder (FLOVENT ROTADISK) at 50 and 100 mcg twice daily was conducted in the U.S. in 325 prepubescent children (244 males and 81 females) aged 4 to 11 years. The mean growth velocities at 52 weeks observed in the intent-to-treat population were 6.32 cm/year in the placebo group (n = 76), 6.07 cm/year in the 50-mcg group (n = 98), and 5.66 cm/year in the 100-mcg group (n = 89). An imbalance in the proportion of children entering puberty between groups and a higher dropout rate in the placebo group due to poorly controlled asthma may be confounding factors in interpreting these data. A separate subset analysis of children who remained prepubertal during the trial revealed growth rates at 52 weeks of 6.10 cm/year in the placebo group (n = 57), 5.91 cm/year in the 50-mcg group (n = 74), and 5.67 cm/year in the 100-mcg group (n = 79). In children aged 8.5 years, the mean age of children in this trial, the range for expected growth velocity is: boys – 3rd percentile = 3.8 cm/year, 50th percentile = 5.4 cm/year, and 97th percentile = 7.0 cm/year; girls – 3rd percentile = 4.2 cm/year, 50th percentile = 5.7 cm/year, and 97th percentile = 7.3 cm/year. The clinical relevance of these growth data is not certain.

If a child or adolescent on any corticosteroid appears to have growth suppression, the possibility that he/she is particularly sensitive to this effect of corticosteroids should be considered. The potential growth effects of prolonged treatment should be weighed against the clinical benefits obtained. To minimize the systemic effects of orally inhaled corticosteroids, including ADVAIR DISKUS, each patient should be titrated to the lowest strength that effectively controls his/her asthma [*see Dosage and Administration (2.1)*].

8.5 Geriatric Use

Clinical trials of ADVAIR DISKUS for asthma did not include sufficient numbers of subjects aged 65 years and older to determine whether older subjects with asthma respond differently than younger subjects.

Of the total number of subjects in clinical trials receiving ADVAIR DISKUS for COPD, 1,621 were aged 65 years and older and 379 were aged 75 years and older. Subjects with COPD aged

65 years and older had a higher incidence of serious adverse events compared with subjects younger than 65 years. Although the distribution of adverse events was similar in the 2 age groups, subjects older than 65 years experienced more severe events. In two 1-year trials, the excess risk of pneumonia that was seen in subjects treated with ADVAIR DISKUS compared with those treated with salmeterol was greater in subjects older than 65 years than in subjects younger than 65 years [see *Adverse Reactions (6.2)*]. As with other products containing beta₂-agonists, special caution should be observed when using ADVAIR DISKUS in geriatric patients who have concomitant cardiovascular disease that could be adversely affected by beta₂-agonists. Based on available data for ADVAIR DISKUS or its active components, no adjustment of dosage of ADVAIR DISKUS in geriatric patients is warranted.

No relationship between fluticasone propionate systemic exposure and age was observed in 57 subjects with COPD (aged 40 to 82 years) given 250 or 500 mcg twice daily.

8.6 Hepatic Impairment

Formal pharmacokinetic studies using ADVAIR DISKUS have not been conducted in patients with hepatic impairment. However, since both fluticasone propionate and salmeterol are predominantly cleared by hepatic metabolism, impairment of liver function may lead to accumulation of fluticasone propionate and salmeterol in plasma. Therefore, patients with hepatic disease should be closely monitored.

8.7 Renal Impairment

Formal pharmacokinetic studies using ADVAIR DISKUS have not been conducted in patients with renal impairment.

10 OVERDOSAGE

No human overdosage data has been reported for ADVAIR DISKUS.

ADVAIR DISKUS contains both fluticasone propionate and salmeterol; therefore, the risks associated with overdosage for the individual components described below apply to ADVAIR DISKUS. Treatment of overdosage consists of discontinuation of ADVAIR DISKUS together with institution of appropriate symptomatic and/or supportive therapy. The judicious use of a cardioselective beta-receptor blocker may be considered, bearing in mind that such medication can produce bronchospasm. Cardiac monitoring is recommended in cases of overdosage.

10.1 Fluticasone Propionate

Chronic overdosage of fluticasone propionate may result in signs/symptoms of hypercorticism [see *Warnings and Precautions (5.8)*]. Inhalation by healthy volunteers of a single dose of 4,000 mcg of fluticasone propionate inhalation powder or single doses of 1,760 or 3,520 mcg of fluticasone propionate CFC inhalation aerosol was well tolerated. Fluticasone propionate given by inhalation aerosol at dosages of 1,320 mcg twice daily for 7 to 15 days to healthy human volunteers was also well tolerated. Repeat oral doses up to 80 mg daily for 10 days in healthy

volunteers and repeat oral doses up to 20 mg daily for 42 days in subjects were well tolerated. Adverse reactions were of mild or moderate severity, and incidences were similar in active and placebo treatment groups.

10.2 Salmeterol

The expected signs and symptoms with overdosage of salmeterol are those of excessive beta-adrenergic stimulation and/or occurrence or exaggeration of any of the signs and symptoms of beta-adrenergic stimulation (e.g., seizures, angina, hypertension or hypotension, tachycardia with rates up to 200 beats/min, arrhythmias, nervousness, headache, tremor, muscle cramps, dry mouth, palpitation, nausea, dizziness, fatigue, malaise, insomnia, hyperglycemia, hypokalemia, metabolic acidosis). Overdosage with salmeterol can lead to clinically significant prolongation of the QTc interval, which can produce ventricular arrhythmias.

As with all inhaled sympathomimetic medicines, cardiac arrest and even death may be associated with an overdose of salmeterol.

11 DESCRIPTION

ADVAIR DISKUS 100/50, ADVAIR DISKUS 250/50, and ADVAIR DISKUS 500/50 are combinations of fluticasone propionate and salmeterol xinafoate.

One active component of ADVAIR DISKUS is fluticasone propionate, a corticosteroid having the chemical name *S*-(fluoromethyl) 6 α ,9-difluoro-11 β ,17-dihydroxy-16 α -methyl-3-oxoandrosta-1,4-diene-17 β -carbothioate, 17-propionate and the following chemical structure:

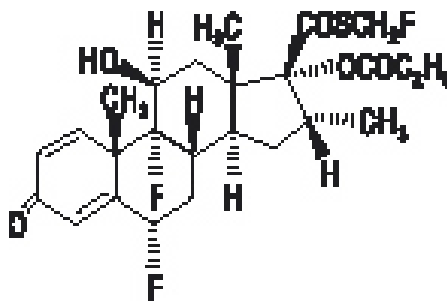

Fluticasone propionate is a white powder with a molecular weight of 500.6, and the empirical formula is C₂₅H₃₁F₃O₅S. It is practically insoluble in water, freely soluble in dimethyl sulfoxide and dimethylformamide, and slightly soluble in methanol and 95% ethanol.

The other active component of ADVAIR DISKUS is salmeterol xinafoate, a beta₂-adrenergic bronchodilator. Salmeterol xinafoate is the racemic form of the 1-hydroxy-2-naphthoic acid salt of salmeterol. It has the chemical name 4-hydroxy- α ¹-[[[6-(4-phenylbutoxy)hexyl]amino]methyl]-1,3-benzenedimethanol, 1-hydroxy-2-naphthalenecarboxylate and the following chemical structure:

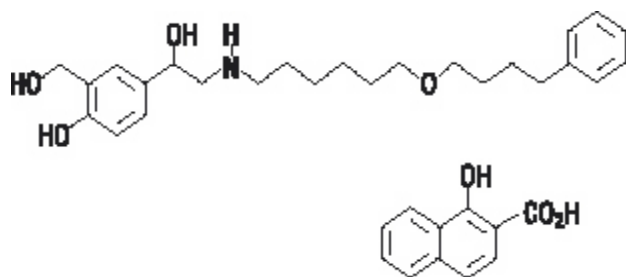

Salmeterol xinafoate is a white powder with a molecular weight of 603.8, and the empirical formula is $C_{25}H_{37}NO_4 \cdot C_{11}H_8O_3$. It is freely soluble in methanol; slightly soluble in ethanol, chloroform, and isopropanol; and sparingly soluble in water.

ADVAIR DISKUS is a purple plastic inhaler containing a foil blister strip. Each blister on the strip contains a white powder mix of micronized fluticasone propionate (100, 250, or 500 mcg) and micronized salmeterol xinafoate salt (72.5 mcg, equivalent to 50 mcg of salmeterol base) in 12.5 mg of formulation containing lactose monohydrate (which contains milk proteins). After the inhaler is activated, the powder is dispersed into the airstream created by the patient inhaling through the mouthpiece.

Under standardized in vitro test conditions, ADVAIR DISKUS delivers 93, 233, and 465 mcg of fluticasone propionate and 45 mcg of salmeterol base per blister from ADVAIR DISKUS 100/50, ADVAIR DISKUS 250/50, and ADVAIR DISKUS 500/50, respectively, when tested at a flow rate of 60 L/min for 2 seconds.

In adult subjects with obstructive lung disease and severely compromised lung function (mean FEV₁ 20% to 30% of predicted), mean peak inspiratory flow (PIF) through the DISKUS inhaler was 82.4 L/min (range: 46.1 to 115.3 L/min).

Inhalation profiles for adolescent (N = 13, aged 12 to 17 years) and adult (N = 17, aged 18 to 50 years) subjects with asthma inhaling maximally through the DISKUS inhaler show mean PIF of 122.2 L/min (range: 81.6 to 152.1 L/min). Inhalation profiles for pediatric subjects with asthma inhaling maximally through the DISKUS inhaler show a mean PIF of 75.5 L/min (range: 49.0 to 104.8 L/min) for the 4-year-old subject set (N = 20) and 107.3 L/min (range: 82.8 to 125.6 L/min) for the 8-year-old subject set (N = 20).

The actual amount of drug delivered to the lung will depend on patient factors, such as inspiratory flow profile.

12 CLINICAL PHARMACOLOGY

12.1 Mechanism of Action

ADVAIR DISKUS

ADVAIR DISKUS contains both fluticasone propionate and salmeterol. The mechanisms of action described below for the individual components apply to ADVAIR DISKUS. These drugs

represent 2 different classes of medications (a synthetic corticosteroid and a LABA) that have different effects on clinical, physiologic, and inflammatory indices.

Fluticasone Propionate

Fluticasone propionate is a synthetic trifluorinated corticosteroid with anti-inflammatory activity. Fluticasone propionate has been shown in vitro to exhibit a binding affinity for the human glucocorticoid receptor that is 18 times that of dexamethasone, almost twice that of beclomethasone-17-monopropionate (BMP), the active metabolite of beclomethasone dipropionate, and over 3 times that of budesonide. Data from the McKenzie vasoconstrictor assay in man are consistent with these results. The clinical significance of these findings is unknown.

Inflammation is an important component in the pathogenesis of asthma. Corticosteroids have been shown to have a wide range of actions on multiple cell types (e.g., mast cells, eosinophils, neutrophils, macrophages, lymphocytes) and mediators (e.g., histamine, eicosanoids, leukotrienes, cytokines) involved in inflammation. These anti-inflammatory actions of corticosteroids contribute to their efficacy in asthma.

Inflammation is also a component in the pathogenesis of COPD. In contrast to asthma, however, the predominant inflammatory cells in COPD include neutrophils, CD8+ T-lymphocytes, and macrophages. The effects of corticosteroids in the treatment of COPD are not well defined and ICS and fluticasone propionate when used apart from ADVAIR DISKUS are not indicated for the treatment of COPD.

Salmeterol Xinafoate

Salmeterol is a selective LABA. In vitro studies show salmeterol to be at least 50 times more selective for beta₂-adrenoceptors than albuterol. Although beta₂-adrenoceptors are the predominant adrenergic receptors in bronchial smooth muscle and beta₁-adrenoceptors are the predominant receptors in the heart, there are also beta₂-adrenoceptors in the human heart comprising 10% to 50% of the total beta-adrenoceptors. The precise function of these receptors has not been established, but their presence raises the possibility that even selective beta₂-agonists may have cardiac effects.

The pharmacologic effects of beta₂-adrenoceptor agonist drugs, including salmeterol, are at least in part attributable to stimulation of intracellular adenylyl cyclase, the enzyme that catalyzes the conversion of adenosine triphosphate (ATP) to cyclic-3',5'-adenosine monophosphate (cyclic AMP). Increased cyclic AMP levels cause relaxation of bronchial smooth muscle and inhibition of release of mediators of immediate hypersensitivity from cells, especially from mast cells.

In vitro tests show that salmeterol is a potent and long-lasting inhibitor of the release of mast cell mediators, such as histamine, leukotrienes, and prostaglandin D₂, from human lung. Salmeterol inhibits histamine-induced plasma protein extravasation and inhibits platelet-activating factor–induced eosinophil accumulation in the lungs of guinea pigs when administered by the inhaled

route. In humans, single doses of salmeterol administered via inhalation aerosol attenuate allergen-induced bronchial hyper-responsiveness.

12.2 Pharmacodynamics

ADVAIR DISKUS

Healthy Subjects: Cardiovascular Effects: Since systemic pharmacodynamic effects of salmeterol are not normally seen at the therapeutic dose, higher doses were used to produce measurable effects. Four (4) trials were conducted with healthy adult subjects: (1) a single-dose crossover trial using 2 inhalations of ADVAIR DISKUS 500/50, fluticasone propionate inhalation powder 500 mcg and salmeterol inhalation powder 50 mcg given concurrently, or fluticasone propionate inhalation powder 500 mcg given alone, (2) a cumulative-dose trial using 50 to 400 mcg of salmeterol inhalation powder given alone or as ADVAIR DISKUS 500/50, (3) a repeat-dose trial for 11 days using 2 inhalations twice daily of ADVAIR DISKUS 250/50, fluticasone propionate inhalation powder 250 mcg, or salmeterol inhalation powder 50 mcg, and (4) a single-dose trial using 5 inhalations of ADVAIR DISKUS 100/50, fluticasone propionate inhalation powder 100 mcg alone, or placebo. In these trials no significant differences were observed in the pharmacodynamic effects of salmeterol (pulse rate, blood pressure, QTc interval, potassium, and glucose) whether the salmeterol was given as ADVAIR DISKUS, concurrently with fluticasone propionate from separate inhalers, or as salmeterol alone. The systemic pharmacodynamic effects of salmeterol were not altered by the presence of fluticasone propionate in ADVAIR DISKUS. The potential effect of salmeterol on the effects of fluticasone propionate on the HPA axis was also evaluated in these trials.

Hypothalamic-Pituitary-Adrenal Axis Effects: No significant differences across treatments were observed in 24-hour urinary cortisol excretion and, where measured, 24-hour plasma cortisol AUC. The systemic pharmacodynamic effects of fluticasone propionate were not altered by the presence of salmeterol in ADVAIR DISKUS in healthy subjects.

Subjects with Asthma: Adult and Adolescent Subjects: Cardiovascular Effects: In clinical trials with ADVAIR DISKUS in adult and adolescent subjects aged 12 years and older with asthma, no significant differences were observed in the systemic pharmacodynamic effects of salmeterol (pulse rate, blood pressure, QTc interval, potassium, and glucose) whether the salmeterol was given alone or as ADVAIR DISKUS. In 72 adult and adolescent subjects with asthma given either ADVAIR DISKUS 100/50 or ADVAIR DISKUS 250/50, continuous 24-hour electrocardiographic monitoring was performed after the first dose and after 12 weeks of therapy, and no clinically significant dysrhythmias were noted.

Hypothalamic-Pituitary-Adrenal Axis Effects: In a 28-week trial in adult and adolescent subjects with asthma, ADVAIR DISKUS 500/50 twice daily was compared with the concurrent use of salmeterol inhalation powder 50 mcg plus fluticasone propionate inhalation powder 500 mcg from separate inhalers or fluticasone propionate inhalation powder 500 mcg

alone. No significant differences across treatments were observed in serum cortisol AUC after 12 weeks of dosing or in 24-hour urinary cortisol excretion after 12 and 28 weeks.

In a 12-week trial in adult and adolescent subjects with asthma, ADVAIR DISKUS 250/50 twice daily was compared with fluticasone propionate inhalation powder 250 mcg alone, salmeterol inhalation powder 50 mcg alone, and placebo. For most subjects, the ability to increase cortisol production in response to stress, as assessed by 30-minute cosyntropin stimulation, remained intact with ADVAIR DISKUS. One subject (3%) who received ADVAIR DISKUS 250/50 had an abnormal response (peak serum cortisol <18 mcg/dL) after dosing, compared with 2 subjects (6%) who received placebo, 2 subjects (6%) who received fluticasone propionate 250 mcg, and no subjects who received salmeterol.

In a repeat-dose, 3-way crossover trial, 1 inhalation twice daily of ADVAIR DISKUS 100/50, FLOVENT DISKUS 100 mcg (fluticasone propionate inhalation powder 100 mcg), or placebo was administered to 20 adult and adolescent subjects with asthma. After 28 days of treatment, geometric mean serum cortisol AUC over 12 hours showed no significant difference between ADVAIR DISKUS and FLOVENT DISKUS or between either active treatment and placebo.

Pediatric Subjects: Hypothalamic-Pituitary-Adrenal Axis Effects: In a 12-week trial in subjects with asthma aged 4 to 11 years who were receiving ICS at trial entry, ADVAIR DISKUS 100/50 twice daily was compared with fluticasone propionate inhalation powder 100 mcg administered twice daily via the DISKUS. The values for 24-hour urinary cortisol excretion at trial entry and after 12 weeks of treatment were similar within each treatment group. After 12 weeks, 24-hour urinary cortisol excretion was also similar between the 2 groups.

Subjects with Chronic Obstructive Pulmonary Disease: Cardiovascular Effects: In clinical trials with ADVAIR DISKUS in subjects with COPD, no significant differences were seen in pulse rate, blood pressure, potassium, and glucose between ADVAIR DISKUS, the individual components of ADVAIR DISKUS, and placebo. In a trial of ADVAIR DISKUS 250/50, 8 subjects (2 [1.1%] in the group given ADVAIR DISKUS 250/50, 1 [0.5%] in the fluticasone propionate 250-mcg group, 3 [1.7%] in the salmeterol group, and 2 [1.1%] in the placebo group) had QTc intervals >470 msec at least 1 time during the treatment period. Five (5) of these 8 subjects had a prolonged QTc interval at baseline.

In a 24-week trial, 130 subjects with COPD received continuous 24-hour electrocardiographic monitoring prior to the first dose and after 4 weeks of twice-daily treatment with either ADVAIR DISKUS 500/50, fluticasone propionate inhalation powder 500 mcg, salmeterol inhalation powder 50 mcg, or placebo. No significant differences in ventricular or supraventricular arrhythmias and heart rate were observed among the groups treated with ADVAIR DISKUS 500/50, the individual components, or placebo. One (1) subject in the fluticasone propionate group experienced atrial flutter/atrial fibrillation, and 1 subject in the group given ADVAIR DISKUS 500/50 experienced heart block. There were 3 cases of

nonsustained ventricular tachycardia (1 each in the placebo, salmeterol, and fluticasone propionate 500-mcg treatment groups).

In 24-week clinical trials in subjects with COPD, the incidence of clinically significant ECG abnormalities (myocardial ischemia, ventricular hypertrophy, clinically significant conduction abnormalities, clinically significant arrhythmias) was lower for subjects who received salmeterol (1%, 9 of 688 subjects who received either salmeterol 50 mcg or ADVAIR DISKUS) compared with placebo (3%, 10 of 370 subjects).

No significant differences with salmeterol 50 mcg alone or in combination with fluticasone propionate as ADVAIR DISKUS 500/50 were observed on pulse rate and systolic and diastolic blood pressure in a subset of subjects with COPD who underwent 12-hour serial vital sign measurements after the first dose (n = 183) and after 12 weeks of therapy (n = 149). Median changes from baseline in pulse rate and systolic and diastolic blood pressure were similar to those seen with placebo.

Hypothalamic-Pituitary-Adrenal Axis Effects: Short-cosyntropin stimulation testing was performed both at Day 1 and Endpoint in 101 subjects with COPD receiving twice-daily ADVAIR DISKUS 250/50, fluticasone propionate inhalation powder 250 mcg, salmeterol inhalation powder 50 mcg, or placebo. For most subjects, the ability to increase cortisol production in response to stress, as assessed by short cosyntropin stimulation, remained intact with ADVAIR DISKUS 250/50. One (1) subject (3%) who received ADVAIR DISKUS 250/50 had an abnormal stimulated cortisol response (peak cortisol <14.5 mcg/dL assessed by high-performance liquid chromatography) after dosing, compared with 2 subjects (9%) who received fluticasone propionate 250 mcg, 2 subjects (7%) who received salmeterol 50 mcg, and 1 subject (4%) who received placebo following 24 weeks of treatment or early discontinuation from trial.

After 36 weeks of dosing, serum cortisol concentrations in a subset of subjects with COPD (n = 83) were 22% lower in subjects receiving ADVAIR DISKUS 500/50 and 21% lower in subjects receiving fluticasone propionate 500 mcg than in subjects receiving placebo.

Other Fluticasone Propionate Products

Subjects with Asthma: Hypothalamic-Pituitary-Adrenal Axis Effects: In clinical trials with fluticasone propionate inhalation powder using dosages up to and including 250 mcg twice daily, occasional abnormal short cosyntropin tests (peak serum cortisol <18 mcg/dL assessed by radioimmunoassay) were noted both in subjects receiving fluticasone propionate and in subjects receiving placebo. The incidence of abnormal tests at 500 mcg twice daily was greater than placebo. In a 2-year trial carried out with the DISKHALER inhalation device in 64 subjects with mild, persistent asthma (mean FEV₁ 91% of predicted) randomized to fluticasone propionate 500 mcg twice daily or placebo, no subject receiving fluticasone propionate had an abnormal response to 6-hour cosyntropin infusion (peak serum cortisol <18 mcg/dL). With a peak cortisol threshold of <35 mcg/dL, 1 subject receiving fluticasone propionate (4%) had an abnormal

response at 1 year; repeat testing at 18 months and 2 years was normal. Another subject receiving fluticasone propionate (5%) had an abnormal response at 2 years. No subject on placebo had an abnormal response at 1 or 2 years.

Subjects with Chronic Obstructive Pulmonary Disease: Hypothalamic-Pituitary-Adrenal Axis Effects: After 4 weeks of dosing, the steady-state fluticasone propionate pharmacokinetics and serum cortisol levels were described in a subset of subjects with COPD (n = 86) randomized to twice-daily fluticasone propionate inhalation powder via the DISKUS 500 mcg, fluticasone propionate inhalation powder 250 mcg, or placebo. Serial serum cortisol concentrations were measured across a 12-hour dosing interval. Serum cortisol concentrations following 250- and 500-mcg twice-daily dosing were 10% and 21% lower than placebo, respectively, indicating a dose-dependent increase in systemic exposure to fluticasone propionate.

Other Salmeterol Xinafoate Products

Subjects with Asthma: Cardiovascular Effects: Inhaled salmeterol, like other beta-adrenergic agonist drugs, can produce dose-related cardiovascular effects and effects on blood glucose and/or serum potassium [see *Warnings and Precautions (5.12, 5.18)*]. The cardiovascular effects (heart rate, blood pressure) associated with salmeterol inhalation aerosol occur with similar frequency, and are of similar type and severity, as those noted following albuterol administration.

The effects of rising inhaled doses of salmeterol and standard inhaled doses of albuterol were studied in volunteers and in subjects with asthma. Salmeterol doses up to 84 mcg administered as inhalation aerosol resulted in heart rate increases of 3 to 16 beats/min, about the same as albuterol dosed at 180 mcg by inhalation aerosol (4 to 10 beats/min). Adult and adolescent subjects receiving 50-mcg doses of salmeterol inhalation powder (N = 60) underwent continuous electrocardiographic monitoring during two 12-hour periods after the first dose and after 1 month of therapy, and no clinically significant dysrhythmias were noted.

Concomitant Use of ADVAIR DISKUS with Other Respiratory Medicines

Short-acting Beta₂-agonists: In clinical trials in subjects with asthma, the mean daily need for albuterol by 166 adult and adolescent subjects aged 12 years and older using ADVAIR DISKUS was approximately 1.3 inhalations/day and ranged from 0 to 9 inhalations/day. Five percent (5%) of subjects using ADVAIR DISKUS in these trials averaged 6 or more inhalations per day over the course of the 12-week trials. No increase in frequency of cardiovascular adverse events was observed among subjects who averaged 6 or more inhalations per day.

In a clinical trial in subjects with COPD, the mean daily need for albuterol for subjects using ADVAIR DISKUS 250/50 was 4.1 inhalations/day. Twenty-six percent (26%) of subjects using ADVAIR DISKUS 250/50 averaged 6 or more inhalations of albuterol per day over the course of the 24-week trial. No increase in frequency of cardiovascular adverse reactions was observed among subjects who averaged 6 or more inhalations per day.

Methylxanthines: The concurrent use of intravenously or orally administered methylxanthines (e.g., aminophylline, theophylline) by adult and adolescent subjects aged 12 years and older receiving ADVAIR DISKUS has not been completely evaluated. In clinical trials in subjects with asthma, 39 subjects receiving ADVAIR DISKUS 100/50, ADVAIR DISKUS 250/50, or ADVAIR DISKUS 500/50 twice daily concurrently with a theophylline product had adverse event rates similar to those in 304 subjects receiving ADVAIR DISKUS without theophylline. Similar results were observed in subjects receiving salmeterol 50 mcg plus fluticasone propionate 500 mcg twice daily concurrently with a theophylline product (n = 39) or without theophylline (n = 132).

In a clinical trial in subjects with COPD, 17 subjects receiving ADVAIR DISKUS 250/50 twice daily concurrently with a theophylline product had adverse event rates similar to those in 161 subjects receiving ADVAIR DISKUS without theophylline. Based on the available data, the concomitant administration of methylxanthines with ADVAIR DISKUS did not alter the observed adverse event profile.

Fluticasone Propionate Nasal Spray: In adult and adolescent subjects aged 12 years and older receiving ADVAIR DISKUS in clinical trials, no difference in the profile of adverse events or HPA axis effects was noted between subjects who were receiving FLONASE (fluticasone propionate) Nasal Spray, 50 mcg concurrently (n = 46) and those who were not (n = 130).

12.3 Pharmacokinetics

Absorption

Fluticasone Propionate: Healthy Subjects: Fluticasone propionate acts locally in the lung; therefore, plasma levels do not predict therapeutic effect. Trials using oral dosing of labeled and unlabeled drug have demonstrated that the oral systemic bioavailability of fluticasone propionate is negligible (<1%), primarily due to incomplete absorption and presystemic metabolism in the gut and liver. In contrast, the majority of the fluticasone propionate delivered to the lung is systemically absorbed.

Following administration of ADVAIR DISKUS to healthy adult subjects, peak plasma concentrations of fluticasone propionate were achieved in 1 to 2 hours. In a single-dose crossover trial, a higher-than-recommended dose of ADVAIR DISKUS was administered to 14 healthy adult subjects. Two (2) inhalations of the following treatments were administered: ADVAIR DISKUS 500/50, fluticasone propionate inhalation powder 500 mcg and salmeterol inhalation powder 50 mcg given concurrently, and fluticasone propionate inhalation powder 500 mcg alone. Mean peak plasma concentrations of fluticasone propionate averaged 107, 94, and 120 pg/mL, respectively, indicating no significant changes in systemic exposures of fluticasone propionate.

In 15 healthy subjects, systemic exposure to fluticasone propionate from 4 inhalations of ADVAIR HFA 230/21 (fluticasone propionate 230 mcg and salmeterol 21 mcg) Inhalation

Aerosol (920/84 mcg) and 2 inhalations of ADVAIR DISKUS 500/50 (1,000/100 mcg) was similar between the 2 inhalers (i.e., 799 versus 832 pg•h/mL, respectively), but approximately half the systemic exposure from 4 inhalations of fluticasone propionate CFC inhalation aerosol 220 mcg (880 mcg, AUC = 1,543 pg•h/mL). Similar results were observed for peak fluticasone propionate plasma concentrations (186 and 182 pg/mL from ADVAIR HFA and ADVAIR DISKUS, respectively, and 307 pg/mL from the fluticasone propionate CFC inhalation aerosol). Absolute bioavailability of fluticasone propionate was 5.3% and 5.5% following administration of ADVAIR HFA and ADVAIR DISKUS, respectively.

Subjects with Asthma and COPD: Peak steady-state fluticasone propionate plasma concentrations in adult subjects with asthma (N = 11) ranged from undetectable to 266 pg/mL after a 500-mcg twice-daily dose of fluticasone propionate inhalation powder using the DISKUS inhaler. The mean fluticasone propionate plasma concentration was 110 pg/mL.

Full pharmacokinetic profiles were obtained from 9 female and 16 male subjects with asthma given fluticasone propionate inhalation powder 500 mcg twice daily using the DISKUS inhaler and from 14 female and 43 male subjects with COPD given 250 or 500 mcg twice daily. No overall differences in fluticasone propionate pharmacokinetics were observed.

Peak steady-state fluticasone propionate plasma concentrations in subjects with COPD averaged 53 pg/mL (range: 19.3 to 159.3 pg/mL) after treatment with 250 mcg twice daily (n = 30) and 84 pg/mL (range: 24.3 to 197.1 pg/mL) after treatment with 500 mcg twice daily (n = 27) via the fluticasone propionate DISKUS inhaler. In another trial in subjects with COPD, peak steady-state fluticasone propionate plasma concentrations averaged 115 pg/mL (range: 52.6 to 366.0 pg/mL) after treatment with 500 mcg twice daily via the fluticasone propionate DISKUS inhaler (n = 15) and 105 pg/mL (range: 22.5 to 299.0 pg/mL) via ADVAIR DISKUS (n = 24).

Salmeterol Xinafoate: Healthy Subjects: Salmeterol xinafoate, an ionic salt, dissociates in solution so that the salmeterol and 1-hydroxy-2-naphthoic acid (xinafoate) moieties are absorbed, distributed, metabolized, and eliminated independently. Salmeterol acts locally in the lung; therefore, plasma levels do not predict therapeutic effect.

Following administration of ADVAIR DISKUS to healthy adult subjects, peak plasma concentrations of salmeterol were achieved in about 5 minutes.

In 15 healthy subjects receiving ADVAIR HFA 230/21 Inhalation Aerosol (920/84 mcg) and ADVAIR DISKUS 500/50 (1,000/100 mcg), systemic exposure to salmeterol was higher (317 versus 169 pg•h/mL) and peak salmeterol concentrations were lower (196 versus 223 pg/mL) following ADVAIR HFA compared with ADVAIR DISKUS, although pharmacodynamic results were comparable.

Subjects with Asthma: Because of the small therapeutic dose, systemic levels of salmeterol are low or undetectable after inhalation of recommended dosages (50 mcg of salmeterol inhalation powder twice daily). Following chronic administration of an inhaled dose

of 50 mcg of salmeterol inhalation powder twice daily, salmeterol was detected in plasma within 5 to 45 minutes in 7 subjects with asthma; plasma concentrations were very low, with mean peak concentrations of 167 pg/mL at 20 minutes and no accumulation with repeated doses.

Distribution

Fluticasone Propionate: Following intravenous administration, the initial disposition phase for fluticasone propionate was rapid and consistent with its high lipid solubility and tissue binding. The volume of distribution averaged 4.2 L/kg.

The percentage of fluticasone propionate bound to human plasma proteins averages 99%. Fluticasone propionate is weakly and reversibly bound to erythrocytes and is not significantly bound to human transcortin.

Salmeterol: The percentage of salmeterol bound to human plasma proteins averages 96% in vitro over the concentration range of 8 to 7,722 ng of salmeterol base per milliliter, much higher concentrations than those achieved following therapeutic doses of salmeterol.

Metabolism

Fluticasone Propionate: The total clearance of fluticasone propionate is high (average, 1,093 mL/min), with renal clearance accounting for <0.02% of the total. The only circulating metabolite detected in man is the 17 β -carboxylic acid derivative of fluticasone propionate, which is formed through the CYP3A4 pathway. This metabolite had less affinity (approximately 1/2,000) than the parent drug for the glucocorticoid receptor of human lung cytosol in vitro and negligible pharmacological activity in animal studies. Other metabolites detected in vitro using cultured human hepatoma cells have not been detected in man.

Salmeterol: Salmeterol base is extensively metabolized by hydroxylation, with subsequent elimination predominantly in the feces. No significant amount of unchanged salmeterol base was detected in either urine or feces.

An in vitro study using human liver microsomes showed that salmeterol is extensively metabolized to α -hydroxysalmeterol (aliphatic oxidation) by CYP3A4. Ketoconazole, a strong inhibitor of CYP3A4, essentially completely inhibited the formation of α -hydroxysalmeterol in vitro.

Elimination

Fluticasone Propionate: Following intravenous dosing, fluticasone propionate showed polyexponential kinetics and had a terminal elimination half-life of approximately 7.8 hours. Less than 5% of a radiolabeled oral dose was excreted in the urine as metabolites, with the remainder excreted in the feces as parent drug and metabolites. Terminal half-life estimates of fluticasone propionate for ADVAIR HFA, ADVAIR DISKUS, and fluticasone propionate CFC inhalation aerosol were similar and averaged 5.6 hours.

Salmeterol: In 2 healthy adult subjects who received 1 mg of radiolabeled salmeterol (as salmeterol xinafoate) orally, approximately 25% and 60% of the radiolabeled salmeterol was eliminated in urine and feces, respectively, over a period of 7 days. The terminal elimination half-life was about 5.5 hours (1 volunteer only).

The xinafoate moiety has no apparent pharmacologic activity. The xinafoate moiety is highly protein bound (>99%) and has a long elimination half-life of 11 days. No terminal half-life estimates were calculated for salmeterol following administration of ADVAIR DISKUS.

Specific Populations

A population pharmacokinetic analysis was performed for fluticasone propionate and salmeterol utilizing data from 9 controlled clinical trials that included 350 subjects with asthma aged 4 to 77 years who received treatment with ADVAIR DISKUS, the combination of HFA-propelled fluticasone propionate and salmeterol inhalation aerosol (ADVAIR HFA), fluticasone propionate inhalation powder (FLOVENT DISKUS), HFA-propelled fluticasone propionate inhalation aerosol (FLOVENT HFA), or CFC-propelled fluticasone propionate inhalation aerosol. The population pharmacokinetic analyses for fluticasone propionate and salmeterol showed no clinically relevant effects of age, gender, race, body weight, body mass index, or percent of predicted FEV₁ on apparent clearance and apparent volume of distribution.

Age: When the population pharmacokinetic analysis for fluticasone propionate was divided into subgroups based on fluticasone propionate strength, formulation, and age (adolescents/adults and children), there were some differences in fluticasone propionate exposure. Higher fluticasone propionate exposure from ADVAIR DISKUS 100/50 compared with FLOVENT DISKUS 100 mcg was observed in adolescents and adults (ratio 1.52 [90% CI: 1.08, 2.13]). However, in clinical trials of up to 12 weeks' duration comparing ADVAIR DISKUS 100/50 and FLOVENT DISKUS 100 mcg in adolescents and adults, no differences in systemic effects of corticosteroid treatment (e.g., HPA axis effects) were observed. Similar fluticasone propionate exposure was observed from ADVAIR DISKUS 500/50 and FLOVENT DISKUS 500 mcg (ratio 0.83 [90% CI: 0.65, 1.07]) in adolescents and adults.

Steady-state systemic exposure to salmeterol when delivered as ADVAIR DISKUS 100/50, ADVAIR DISKUS 250/50, or ADVAIR HFA 115/21 (fluticasone propionate 115 mcg and salmeterol 21 mcg) Inhalation Aerosol was evaluated in 127 subjects aged 4 to 57 years. The geometric mean AUC was 325 pg•h/mL (90% CI: 309, 341) in adolescents and adults.

The population pharmacokinetic analysis included 160 subjects with asthma aged 4 to 11 years who received ADVAIR DISKUS 100/50 or FLOVENT DISKUS 100 mcg. Higher fluticasone propionate exposure (AUC) was observed in children from ADVAIR DISKUS 100/50 compared with FLOVENT DISKUS 100 mcg (ratio 1.20 [90% CI: 1.06, 1.37]). Higher fluticasone propionate exposure (AUC) from ADVAIR DISKUS 100/50 was observed in children compared with adolescents and adults (ratio 1.63 [90% CI: 1.35, 1.96]). However, in clinical trials of up to 12 weeks' duration comparing ADVAIR DISKUS 100/50 and FLOVENT DISKUS 100 mcg in

both adolescents and adults and in children, no differences in systemic effects of corticosteroid treatment (e.g., HPA axis effects) were observed.

Exposure to salmeterol was higher in children compared with adolescents and adults who received ADVAIR DISKUS 100/50 (ratio 1.23 [90% CI: 1.10, 1.38]). However, in clinical trials of up to 12 weeks' duration with ADVAIR DISKUS 100/50 in both adolescents and adults and in children, no differences in systemic effects of beta₂-agonist treatment (e.g., cardiovascular effects, tremor) were observed.

Male and Female Patients: The population pharmacokinetic analysis involved 202 males and 148 females with asthma who received fluticasone propionate alone or in combination with salmeterol and showed no gender differences for fluticasone propionate pharmacokinetics.

The population pharmacokinetic analysis involved 76 males and 51 females with asthma who received salmeterol in combination with fluticasone propionate and showed no gender differences for salmeterol pharmacokinetics.

Patients with Hepatic and Renal Impairment: Formal pharmacokinetic studies using ADVAIR DISKUS have not been conducted in patients with hepatic or renal impairment. However, since both fluticasone propionate and salmeterol are predominantly cleared by hepatic metabolism, impairment of liver function may lead to accumulation of fluticasone propionate and salmeterol in plasma. Therefore, patients with hepatic disease should be closely monitored.

Drug Interaction Studies

In the repeat- and single-dose trials, there was no evidence of significant drug interaction in systemic exposure between fluticasone propionate and salmeterol when given alone or in combination via the DISKUS. The population pharmacokinetic analysis from 9 controlled clinical trials in 350 subjects with asthma showed no significant effects on fluticasone propionate or salmeterol pharmacokinetics following co-administration with beta₂-agonists, corticosteroids, antihistamines, or theophyllines.

Inhibitors of Cytochrome P450 3A4: Ritonavir: Fluticasone Propionate: Fluticasone propionate is a substrate of CYP3A4. Coadministration of fluticasone propionate and the strong CYP3A4 inhibitor ritonavir is not recommended based upon a multiple-dose, crossover drug interaction trial in 18 healthy subjects. Fluticasone propionate aqueous nasal spray (200 mcg once daily) was coadministered for 7 days with ritonavir (100 mg twice daily). Plasma fluticasone propionate concentrations following fluticasone propionate aqueous nasal spray alone were undetectable (<10 pg/mL) in most subjects, and when concentrations were detectable peak levels (C_{max}) averaged 11.9 pg/mL (range: 10.8 to 14.1 pg/mL) and AUC_(0-τ) averaged 8.43 pg•h/mL (range: 4.2 to 18.8 pg•h/mL). Fluticasone propionate C_{max} and AUC_(0-τ) increased to 318 pg/mL (range: 110 to 648 pg/mL) and 3,102.6 pg•h/mL (range: 1,207.1 to 5,662.0 pg•h/mL), respectively, after coadministration of ritonavir with fluticasone propionate aqueous nasal spray.

This significant increase in plasma fluticasone propionate exposure resulted in a significant decrease (86%) in serum cortisol AUC.

Ketoconazole: Fluticasone Propionate: In a placebo-controlled crossover trial in 8 healthy adult volunteers, coadministration of a single dose of orally inhaled fluticasone propionate (1,000 mcg) with multiple doses of ketoconazole (200 mg) to steady state resulted in increased plasma fluticasone propionate exposure, a reduction in plasma cortisol AUC, and no effect on urinary excretion of cortisol.

Salmeterol: In a placebo-controlled, crossover drug interaction trial in 20 healthy male and female subjects, coadministration of salmeterol (50 mcg twice daily) and the strong CYP3A4 inhibitor ketoconazole (400 mg once daily) for 7 days resulted in a significant increase in plasma salmeterol exposure as determined by a 16-fold increase in AUC (ratio with and without ketoconazole 15.76 [90% CI: 10.66, 23.31]) mainly due to increased bioavailability of the swallowed portion of the dose. Peak plasma salmeterol concentrations were increased by 1.4-fold (90% CI: 1.23, 1.68). Three (3) out of 20 subjects (15%) were withdrawn from salmeterol and ketoconazole coadministration due to beta-agonist-mediated systemic effects (2 with QTc prolongation and 1 with palpitations and sinus tachycardia). Coadministration of salmeterol and ketoconazole did not result in a clinically significant effect on mean heart rate, mean blood potassium, or mean blood glucose. Although there was no statistical effect on the mean QTc, coadministration of salmeterol and ketoconazole was associated with more frequent increases in QTc duration compared with salmeterol and placebo administration.

Erythromycin: Fluticasone Propionate: In a multiple-dose drug interaction trial, coadministration of orally inhaled fluticasone propionate (500 mcg twice daily) and erythromycin (333 mg 3 times daily) did not affect fluticasone propionate pharmacokinetics.

Salmeterol: In a repeat-dose trial in 13 healthy subjects, concomitant administration of erythromycin (a moderate CYP3A4 inhibitor) and salmeterol inhalation aerosol resulted in a 40% increase in salmeterol C_{max} at steady state (ratio with and without erythromycin 1.4 [90% CI: 0.96, 2.03], $P = 0.12$), a 3.6-beat/min increase in heart rate ([95% CI: 0.19, 7.03], $P < 0.04$), a 5.8-msec increase in QTc interval ([95% CI: -6.14, 17.77], $P = 0.34$), and no change in plasma potassium.

13 NONCLINICAL TOXICOLOGY

13.1 Carcinogenesis, Mutagenesis, Impairment of Fertility

Fluticasone Propionate

Fluticasone propionate demonstrated no tumorigenic potential in mice at oral doses up to 1,000 mcg/kg (approximately 5 and 10 times the MRHDID for adults and children, respectively, on a mcg/m² basis) for 78 weeks or in rats at inhalation doses up to 57 mcg/kg (less than and approximately equivalent to the MRHDID for adults and children, respectively, on a mcg/m² basis) for 104 weeks.

Fluticasone propionate did not induce gene mutation in prokaryotic or eukaryotic cells in vitro. No significant clastogenic effect was seen in cultured human peripheral lymphocytes in vitro or in the in vivo mouse micronucleus test.

Fertility and reproductive performance were unaffected in male and female rats at subcutaneous doses up to 50 mcg/kg (approximately 0.5 times the MRHDID for adults on a mcg/m² basis).

Salmeterol

In an 18-month carcinogenicity study in CD-mice, salmeterol at oral doses of 1,400 mcg/kg and above (approximately 20 times the MRHDID for adults and children based on comparison of the plasma AUCs) caused a dose-related increase in the incidence of smooth muscle hyperplasia, cystic glandular hyperplasia, leiomyomas of the uterus, and ovarian cysts. No tumors were seen at 200 mcg/kg (approximately 3 times the MRHDID for adults and children based on comparison of the AUCs).

In a 24-month oral and inhalation carcinogenicity study in Sprague Dawley rats, salmeterol caused a dose-related increase in the incidence of mesovarian leiomyomas and ovarian cysts at doses of 680 mcg/kg and above (approximately 66 and 35 times the MRHDID for adults and children, respectively, on a mcg/m² basis). No tumors were seen at 210 mcg/kg (approximately 20 and 10 times the MRHDID for adults and children, respectively, on a mcg/m² basis). These findings in rodents are similar to those reported previously for other beta-adrenergic agonist drugs. The relevance of these findings to human use is unknown.

Salmeterol produced no detectable or reproducible increases in microbial and mammalian gene mutation in vitro. No clastogenic activity occurred in vitro in human lymphocytes or in vivo in a rat micronucleus test.

Fertility and reproductive performance were unaffected in male and female rats at oral doses up to 2,000 mcg/kg (approximately 195 times the MRHDID for adults on a mcg/m² basis).

13.2 Animal Toxicology and/or Pharmacology

Preclinical

Studies in laboratory animals (minipigs, rodents, and dogs) have demonstrated the occurrence of cardiac arrhythmias and sudden death (with histologic evidence of myocardial necrosis) when beta-agonists and methylxanthines are administered concurrently. The clinical relevance of these findings is unknown.

14 CLINICAL STUDIES

14.1 Asthma

Adult and Adolescent Subjects Aged 12 Years and Older

In clinical trials comparing ADVAIR DISKUS with its individual components, improvements in most efficacy endpoints were greater with ADVAIR DISKUS than with the use of either

fluticasone propionate or salmeterol alone. In addition, clinical trials showed similar results between ADVAIR DISKUS and the concurrent use of fluticasone propionate plus salmeterol at corresponding doses from separate inhalers.

Trials Comparing ADVAIR DISKUS with Fluticasone Propionate Alone or Salmeterol Alone: Three (3) double-blind, parallel-group clinical trials were conducted with ADVAIR DISKUS in 1,208 adult and adolescent subjects (aged 12 years and older, baseline FEV₁ 63% to 72% of predicted normal) with asthma that was not optimally controlled on their current therapy. All treatments were inhalation powders given as 1 inhalation from the DISKUS inhaler twice daily, and other maintenance therapies were discontinued.

Trial 1: Clinical Trial with ADVAIR DISKUS 100/50: This placebo-controlled, 12-week, U.S. trial compared ADVAIR DISKUS 100/50 with its individual components, fluticasone propionate 100 mcg and salmeterol 50 mcg. The trial was stratified according to baseline asthma maintenance therapy; subjects were using either ICS (n = 250) (daily doses of beclomethasone dipropionate 252 to 420 mcg; flunisolide 1,000 mcg; fluticasone propionate inhalation aerosol 176 mcg; or triamcinolone acetonide 600 to 1,000 mcg) or salmeterol (n = 106). Baseline FEV₁ measurements were similar across treatments: ADVAIR DISKUS 100/50, 2.17 L; fluticasone propionate 100 mcg, 2.11 L; salmeterol, 2.13 L; and placebo, 2.15 L.

Predefined withdrawal criteria for lack of efficacy, an indicator of worsening asthma, were utilized for this placebo-controlled trial. Worsening asthma was defined as a clinically important decrease in FEV₁ or PEF, increase in use of VENTOLIN (albuterol, USP) Inhalation Aerosol, increase in night awakenings due to asthma, emergency intervention or hospitalization due to asthma, or requirement for asthma medication not allowed by the protocol. As shown in Table 4, statistically significantly fewer subjects receiving ADVAIR DISKUS 100/50 were withdrawn due to worsening asthma compared with fluticasone propionate, salmeterol, and placebo.

Table 4. Percent of Subjects Withdrawn due to Worsening Asthma in Subjects Previously Treated with Either Inhaled Corticosteroids or Salmeterol (Trial 1)

ADVAIR DISKUS 100/50 (n = 87)	Fluticasone Propionate 100 mcg (n = 85)	Salmeterol 50 mcg (n = 86)	Placebo (n = 77)
3%	11%	35%	49%

The FEV₁ results are displayed in Figure 1. Because this trial used predetermined criteria for worsening asthma, which caused more subjects in the placebo group to be withdrawn, FEV₁ results at Endpoint (last available FEV₁ result) are also provided. Subjects receiving ADVAIR DISKUS 100/50 had significantly greater improvements in FEV₁ (0.51 L, 25%) compared with fluticasone propionate 100 mcg (0.28 L, 15%), salmeterol (0.11 L, 5%), and placebo (0.01 L,

1%). These improvements in FEV₁ with ADVAIR DISKUS were achieved regardless of baseline asthma maintenance therapy (ICS or salmeterol).

Figure 1. Mean Percent Change from Baseline in FEV₁ in Subjects with Asthma Previously Treated with Either Inhaled Corticosteroids or Salmeterol (Trial 1)

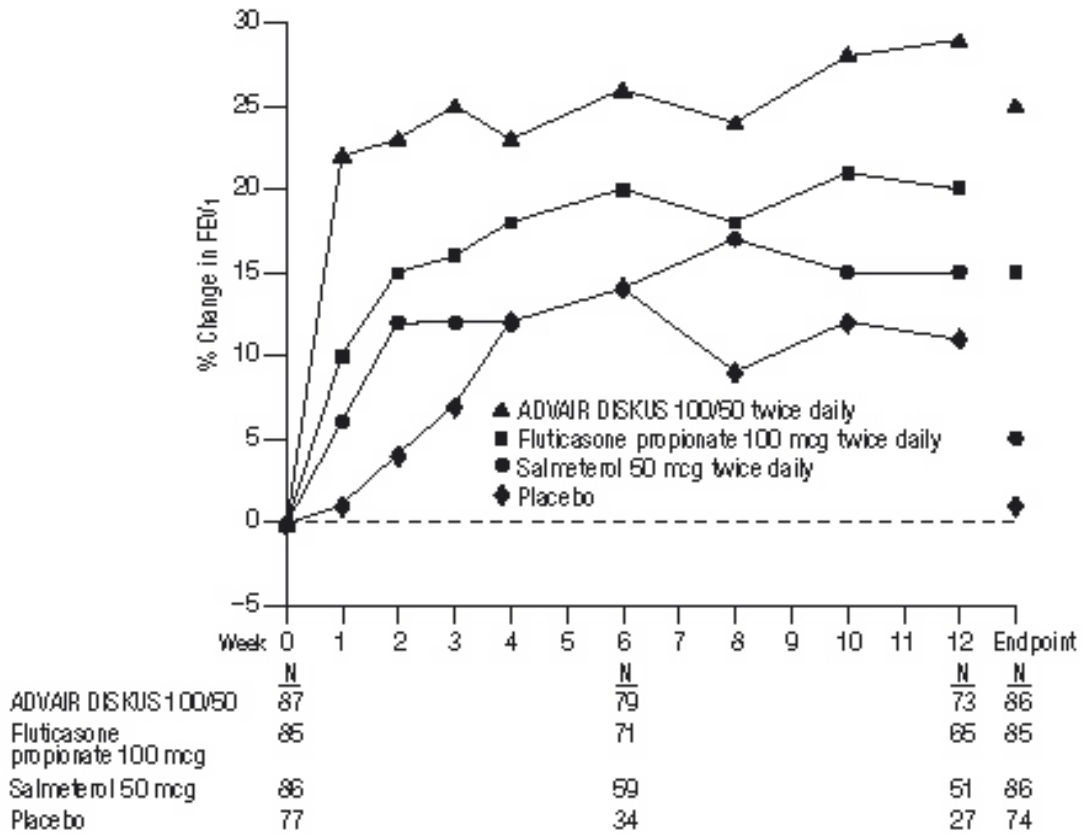

The effect of ADVAIR DISKUS 100/50 on morning and evening PEF endpoints is shown in Table 5.

Table 5. Peak Expiratory Flow Results for Subjects with Asthma Previously Treated with Either Inhaled Corticosteroids or Salmeterol (Trial 1)

Efficacy Variable^a	ADVAIR DISKUS 100/50 (n = 87)	Fluticasone Propionate 100 mcg (n = 85)	Salmeterol 50 mcg (n = 86)	Placebo (n = 77)
AM PEF (L/min)				
Baseline	393	374	369	382
Change from baseline	53	17	-2	-24
PM PEF (L/min)				
Baseline	418	390	396	398
Change from baseline	35	18	-7	-13

^a Change from baseline = change from baseline at Endpoint (last available data).

The subjective impact of asthma on subjects' perception of health was evaluated through use of an instrument called the Asthma Quality of Life Questionnaire (AQLQ) (based on a 7-point scale where 1 = maximum impairment and 7 = none). Subjects receiving ADVAIR DISKUS 100/50 had clinically meaningful improvements in overall asthma-specific quality of life as defined by a difference between groups of ≥ 0.5 points in change from baseline AQLQ scores (difference in AQLQ score of 1.25 compared with placebo).

Trial 2: Clinical Trial with ADVAIR DISKUS 250/50: This placebo-controlled, 12-week, U.S. trial compared ADVAIR DISKUS 250/50 with its individual components, fluticasone propionate 250 mcg and salmeterol 50 mcg, in 349 subjects with asthma using ICS (daily doses of beclomethasone dipropionate 462 to 672 mcg; flunisolide 1,250 to 2,000 mcg; fluticasone propionate inhalation aerosol 440 mcg; or triamcinolone acetonide 1,100 to 1,600 mcg). Baseline FEV₁ measurements were similar across treatments: ADVAIR DISKUS 250/50, 2.23 L; fluticasone propionate 250 mcg, 2.12 L; salmeterol, 2.20 L; and placebo, 2.19 L.

Efficacy results in this trial were similar to those observed in Trial 1. Subjects receiving ADVAIR DISKUS 250/50 had significantly greater improvements in FEV₁ (0.48 L, 23%) compared with fluticasone propionate 250 mcg (0.25 L, 13%), salmeterol (0.05 L, 4%), and placebo (decrease of 0.11 L, decrease of 5%). Statistically significantly fewer subjects receiving ADVAIR DISKUS 250/50 were withdrawn from this trial for worsening asthma (4%) compared with fluticasone propionate (22%), salmeterol (38%), and placebo (62%). In addition, ADVAIR DISKUS 250/50 was superior to fluticasone propionate, salmeterol, and placebo for improvements in morning and evening PEF. Subjects receiving ADVAIR DISKUS 250/50 also had clinically meaningful improvements in overall asthma-specific quality of life as described in Trial 1 (difference in AQLQ score of 1.29 compared with placebo).

Trial 3: Clinical Trial with ADVAIR DISKUS 500/50: This 28-week, non-U.S. trial compared ADVAIR DISKUS 500/50 with fluticasone propionate 500 mcg alone and concurrent

therapy (salmeterol 50 mcg plus fluticasone propionate 500 mcg administered from separate inhalers) twice daily in 503 subjects with asthma using ICS (daily doses of beclomethasone dipropionate 1,260 to 1,680 mcg; budesonide 1,500 to 2,000 mcg; flunisolide 1,500 to 2,000 mcg; or fluticasone propionate inhalation aerosol 660 to 880 mcg [750 to 1,000 mcg inhalation powder]). The primary efficacy parameter, morning PEF, was collected daily for the first 12 weeks of the trial. The primary purpose of weeks 13 to 28 was to collect safety data.

Baseline PEF measurements were similar across treatments: ADVAIR DISKUS 500/50, 359 L/min; fluticasone propionate 500 mcg, 351 L/min; and concurrent therapy, 345 L/min. Morning PEF improved significantly with ADVAIR DISKUS 500/50 compared with fluticasone propionate 500 mcg over the 12-week treatment period. Improvements in morning PEF observed with ADVAIR DISKUS 500/50 were similar to improvements observed with concurrent therapy.

Onset of Action and Progression of Improvement in Asthma Control: The onset of action and progression of improvement in asthma control were evaluated in the 2 placebo-controlled U.S. trials. Following the first dose, the median time to onset of clinically significant bronchodilatation ($\geq 15\%$ improvement in FEV₁) in most subjects was seen within 30 to 60 minutes. Maximum improvement in FEV₁ generally occurred within 3 hours, and clinically significant improvement was maintained for 12 hours (Figure 2). Following the initial dose, predose FEV₁ relative to Day 1 baseline improved markedly over the first week of treatment and continued to improve over the 12 weeks of treatment in both trials. No diminution in the 12-hour bronchodilator effect was observed with either ADVAIR DISKUS 100/50 (Figures 2 and 3) or ADVAIR DISKUS 250/50 as assessed by FEV₁ following 12 weeks of therapy.

Figure 2. Percent Change in Serial 12-Hour FEV₁ in Subjects with Asthma Previously Using Either Inhaled Corticosteroids or Salmeterol (Trial 1)

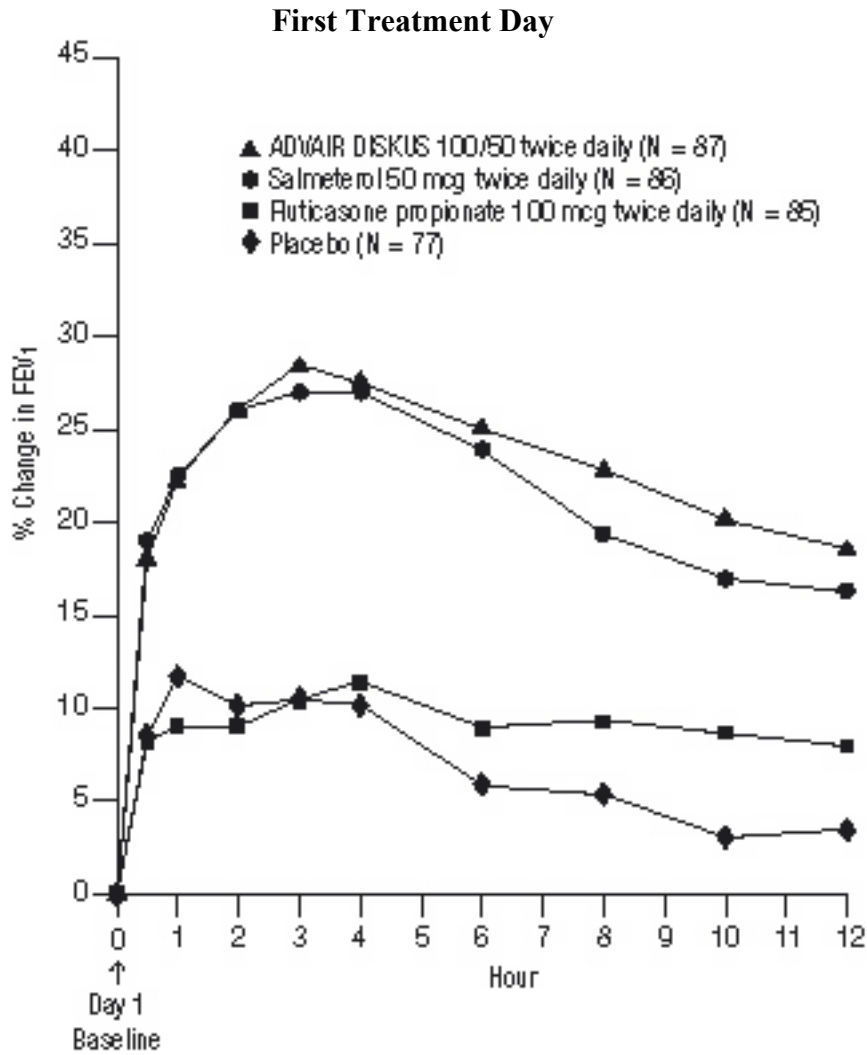
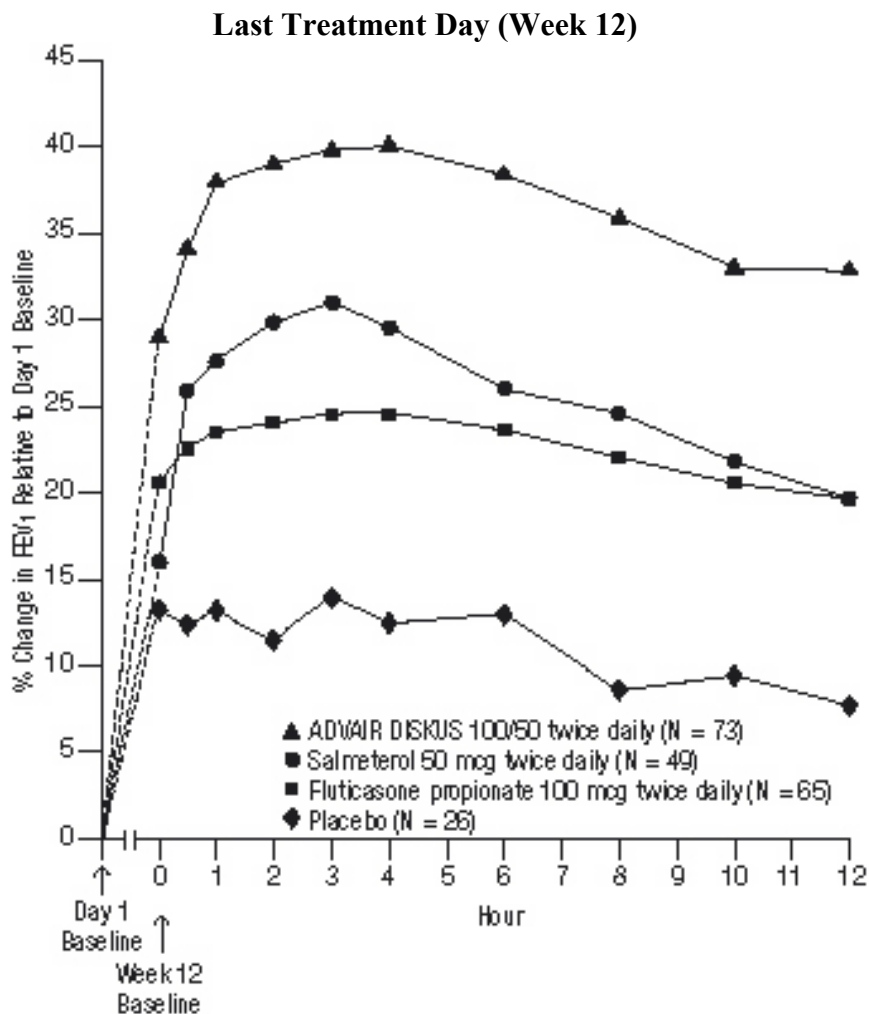

Figure 3. Percent Change in Serial 12-Hour FEV₁ in Subjects with Asthma Previously Using Either Inhaled Corticosteroids or Salmeterol (Trial 1)



Reduction in asthma symptoms and use of rescue VENTOLIN Inhalation Aerosol and improvement in morning and evening PEF also occurred within the first day of treatment with ADVAIR DISKUS, and continued to improve over the 12 weeks of therapy in both trials.

Pediatric Subjects

In a 12-week U.S. trial, ADVAIR DISKUS 100/50 twice daily was compared with fluticasone propionate inhalation powder 100 mcg twice daily in 203 children with asthma aged 4 to 11 years. At trial entry, the children were symptomatic on low doses of ICS (beclomethasone dipropionate 252 to 336 mcg/day; budesonide 200 to 400 mcg/day; flunisolide 1,000 mcg/day; triamcinolone acetonide 600 to 1,000 mcg/day; or fluticasone propionate 88 to 250 mcg/day). The primary objective of this trial was to determine the safety of ADVAIR DISKUS 100/50 compared with fluticasone propionate inhalation powder 100 mcg in this age group; however, the

trial also included secondary efficacy measures of pulmonary function. Morning predose FEV₁ was obtained at baseline and Endpoint (last available FEV₁ result) in children aged 6 to 11 years. In subjects receiving ADVAIR DISKUS 100/50, FEV₁ increased from 1.70 L at baseline (n = 79) to 1.88 L at Endpoint (n = 69) compared with an increase from 1.65 L at baseline (n = 83) to 1.77 L at Endpoint (n = 75) in subjects receiving fluticasone propionate 100 mcg.

The findings of this trial, along with extrapolation of efficacy data from subjects aged 12 years and older, support the overall conclusion that ADVAIR DISKUS 100/50 is efficacious in the treatment of asthma in subjects aged 4 to 11 years.

Safety and Efficacy Trials Comparing ADVAIR DISKUS with Fluticasone Propionate

Serious Asthma-Related Events: Two 26-week, randomized, double-blind, parallel-group, active comparator trials were conducted to compare the safety and efficacy of ADVAIR DISKUS with fluticasone propionate inhalation powder in adult and adolescent subjects (Trial 4, NCT01475721) and in pediatric subjects aged 4 to 11 years (Trial 5, NCT01462344). The primary safety objective of both trials was to evaluate whether the addition of salmeterol xinafoate to fluticasone propionate therapy (ADVAIR DISKUS) was non-inferior to ICS fluticasone propionate in terms of the risk of a serious asthma-related event (hospitalization, endotracheal intubation, and death). The trials were designed to rule out pre-defined risk margins for serious asthma-related events of 2.0 for Trial 4 and 2.7 for Trial 5. A blinded adjudication committee determined whether events were asthma related.

Trial 4 enrolled subjects with moderate to severe persistent asthma with a history of asthma-related hospitalization or at least 1 asthma exacerbation in the previous year treated with systemic corticosteroids. A total of 11,679 adult and adolescent subjects [5,834 receiving ADVAIR DISKUS 100/50, ADVAIR DISKUS 250/50, or ADVAIR DISKUS 500/50 and 5,845 receiving fluticasone propionate inhalation powder (100, 250, or 500 mcg)] were included. Trial 5 enrolled subjects with a diagnosis of asthma and a history of at least 1 asthma exacerbation in the previous year treated with systemic corticosteroid. A total of 6,208 subjects aged 4 to 11 years [3,107 receiving ADVAIR DISKUS 100/50 or ADVAIR DISKUS 250/50 and 3,101 receiving fluticasone propionate inhalation powder (100 or 250 mcg)] were included. In both trials, subjects with life-threatening asthma were excluded. In Trials 4 and 5, ADVAIR DISKUS was non-inferior to fluticasone propionate in terms of time to first serious asthma-related events based on the pre-specified risk margins, with estimated hazard ratios of 1.03 (95% CI: 0.64, 1.66) and 1.29 (95% CI: 0.73, 2.27), respectively (Table 6).

Table 6. Serious Asthma-Related Events in the 26-Week Trials 4 and 5

	Adult and Adolescent Subjects Aged 12 Years and Older (Trial 4)		Pediatric Subjects Aged 4 to 11 Years (Trial 5)	
	ADVAIR DISKUS (n = 5,834)	Fluticasone Propionate Inhalation Powder (n = 5,845)	ADVAIR DISKUS (n = 3,107)	Fluticasone Propionate Inhalation Powder (n = 3,101)
Serious asthma-related event (hospitalization, endotracheal intubation, and death) ^a	34 (0.6%)	33 (0.6%)	27 (0.9%)	21 (0.7%)
Hazard ratio (ADVAIR DISKUS/fluticasone propionate)	1.03 (0.64-1.66) ^b		1.29 (0.73-2.27) ^b	
Asthma-related death	0	0	0	0
Asthma-related intubation (endotracheal)	0	2	0	0
Asthma-related hospitalization (≥24-hour stay)	34	33	27	21

^a Number of subjects with event that occurred within 6 months after the first use of study drug or 7 days after the last date of study drug treatment, whichever date was later. Subjects can have one or more events, but only the first event was counted for analysis. A blinded adjudication committee determined whether events were asthma related.

^b The hazard ratio for time to first event was based on a Cox proportional hazards model with a single covariate of treatment (ADVAIR DISKUS vs. fluticasone propionate) and baseline hazards stratified by incoming asthma medication/asthma control status. If the resulting upper 95% CI estimate for the relative risk was <2.0 (Trial 4) or <2.7 (Trial 5), then non-inferiority was concluded.

Effect on Exacerbation: Trials 4 and 5 included time to first exacerbation as a secondary endpoint, where exacerbation was defined as a deterioration of asthma requiring the use of systemic corticosteroids for at least 3 days or an in-patient hospitalization or emergency department visit due to asthma that required systemic corticosteroids. In Trials 4 and 5, the hazard ratio for the time to first asthma exacerbation for ADVAIR DISKUS relative to fluticasone propionate inhalation powder was 0.79 (95% CI: 0.70, 0.89) and 0.86 (95% CI: 0.73, 1.01), respectively. The difference in exacerbations was primarily driven by a reduction in those requiring systemic corticosteroids only.

14.2 Chronic Obstructive Pulmonary Disease

The efficacy of ADVAIR DISKUS 250/50 and ADVAIR DISKUS 500/50 in the treatment of subjects with COPD was evaluated in 6 randomized, double-blind, parallel-group clinical trials in adult subjects aged 40 years and older. These trials were primarily designed to evaluate the efficacy of ADVAIR DISKUS on lung function (3 trials), exacerbations (2 trials), and survival (1 trial).

Lung Function

Two (2) of the 3 clinical trials primarily designed to evaluate the efficacy of ADVAIR DISKUS on lung function were conducted in 1,414 subjects with COPD associated with chronic bronchitis. In these 2 trials, all the subjects had a history of cough productive of sputum that was not attributable to another disease process on most days for at least 3 months of the year for at least 2 years. The trials were randomized, double-blind, parallel-group, 24-week treatment duration. One (1) trial evaluated the efficacy of ADVAIR DISKUS 250/50 compared with its components fluticasone propionate 250 mcg and salmeterol 50 mcg and with placebo, and the other trial evaluated the efficacy of ADVAIR DISKUS 500/50 compared with its components fluticasone propionate 500 mcg and salmeterol 50 mcg and with placebo. Trial treatments were inhalation powders given as 1 inhalation from the DISKUS inhaler twice daily. Maintenance COPD therapies were discontinued, with the exception of theophylline. The subjects had a mean pre-bronchodilator FEV₁ of 41% and 20% reversibility at trial entry. Percent reversibility was calculated as 100 times (FEV₁ post-albuterol minus FEV₁ pre-albuterol)/FEV₁ pre-albuterol.

Improvements in lung function (as defined by predose and postdose FEV₁) were significantly greater with ADVAIR DISKUS than with fluticasone propionate, salmeterol, or placebo. The improvement in lung function with ADVAIR DISKUS 500/50 was similar to the improvement seen with ADVAIR DISKUS 250/50.

Figures 4 and 5 display predose and 2-hour postdose, respectively, FEV₁ results for the trial with ADVAIR DISKUS 250/50. To account for subject withdrawals during the trial, FEV₁ at Endpoint (last evaluable FEV₁) was evaluated. Subjects receiving ADVAIR DISKUS 250/50 had significantly greater improvements in predose FEV₁ at Endpoint (165 mL, 17%) compared with salmeterol 50 mcg (91 mL, 9%) and placebo (1 mL, 1%), demonstrating the contribution of fluticasone propionate to the improvement in lung function with ADVAIR DISKUS (Figure 4). Subjects receiving ADVAIR DISKUS 250/50 had significantly greater improvements in postdose FEV₁ at Endpoint (281 mL, 27%) compared with fluticasone propionate 250 mcg (147 mL, 14%) and placebo (58 mL, 6%), demonstrating the contribution of salmeterol to the improvement in lung function with ADVAIR DISKUS (Figure 5).

Figure 4. Predose FEV₁: Mean Percent Change from Baseline in Subjects with Chronic Obstructive Pulmonary Disease

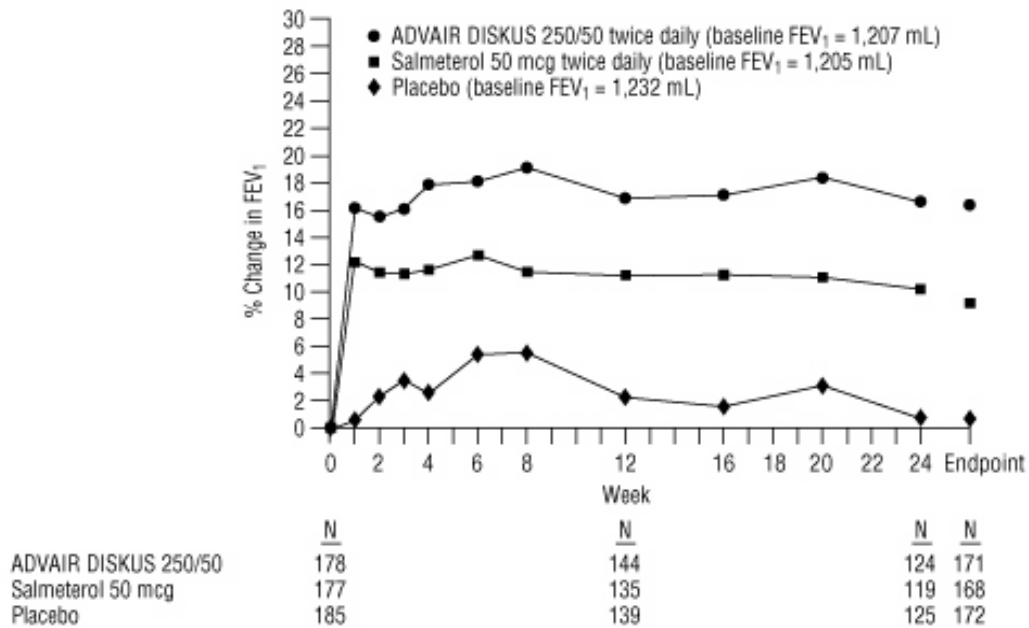
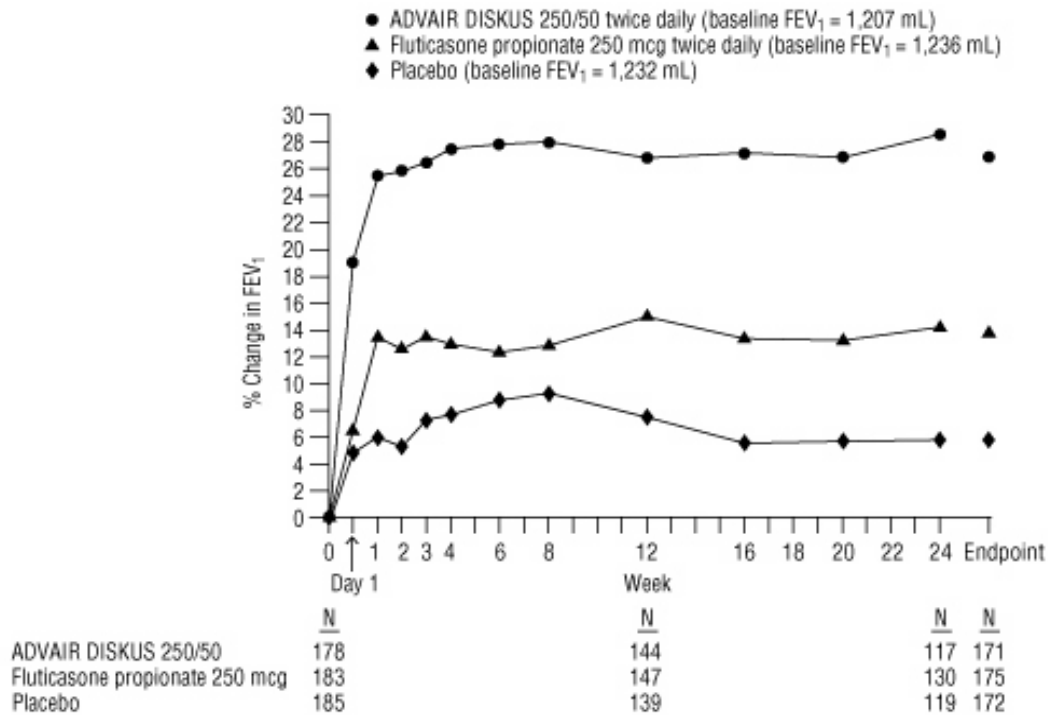

Figure 5. Two-Hour Postdose FEV₁: Mean Percent Changes from Baseline over Time in Subjects with Chronic Obstructive Pulmonary Disease



The third trial was a 1-year trial that evaluated ADVAIR DISKUS 500/50, fluticasone propionate 500 mcg, salmeterol 50 mcg, and placebo in 1,465 subjects. The subjects had an established history of COPD and exacerbations, a pre-bronchodilator FEV₁ <70% of predicted at trial entry, and 8.3% reversibility. The primary endpoint was the comparison of pre-bronchodilator FEV₁ in the groups receiving ADVAIR DISKUS 500/50 or placebo. Subjects treated with ADVAIR DISKUS 500/50 had greater improvements in FEV₁ (113 mL, 10%) compared with fluticasone propionate 500 mcg (7 mL, 2%), salmeterol (15 mL, 2%), and placebo (-60 mL, -3%).

Exacerbations

Two (2) trials were primarily designed to evaluate the effect of ADVAIR DISKUS 250/50 on exacerbations. In these 2 trials, exacerbations were defined as worsening of 2 or more major symptoms (dyspnea, sputum volume, and sputum purulence) or worsening of any 1 major symptom together with any 1 of the following minor symptoms: sore throat, colds (nasal discharge and/or nasal congestion), fever without other cause, and increased cough or wheeze for at least 2 consecutive days. COPD exacerbations were considered of moderate severity if treatment with systemic corticosteroids and/or antibiotics was required and were considered severe if hospitalization was required.

Exacerbations were also evaluated as a secondary outcome in the 1- and 3-year trials with ADVAIR DISKUS 500/50. There was not a symptomatic definition of exacerbation in these 2 trials. Exacerbations were defined in terms of severity requiring treatment with antibiotics and/or systemic corticosteroids (moderately severe) or requiring hospitalization (severe).

The 2 exacerbation trials with ADVAIR DISKUS 250/50 were identical trials designed to evaluate the effect of ADVAIR DISKUS 250/50 and salmeterol 50 mcg, each given twice daily, on exacerbations of COPD over a 12-month period. A total of 1,579 subjects had an established history of COPD (but no other significant respiratory disorders). Subjects had a pre-bronchodilator FEV₁ of 33% of predicted, a mean reversibility of 23% at baseline, and a history of ≥1 COPD exacerbation in the previous year that was moderate or severe. All subjects were treated with ADVAIR DISKUS 250/50 twice daily during a 4-week run-in period prior to being assigned trial treatment with twice-daily ADVAIR DISKUS 250/50 or salmeterol 50 mcg. In both trials, treatment with ADVAIR DISKUS 250/50 resulted in a significantly lower annual rate of moderate/severe COPD exacerbations compared with salmeterol (30.5% reduction [95% CI: 17.0, 41.8], *P*<0.001) in the first trial and (30.4% reduction [95% CI: 16.9, 41.7], *P*<0.001) in the second trial. Subjects treated with ADVAIR DISKUS 250/50 also had a significantly lower annual rate of exacerbations requiring treatment with oral corticosteroids compared with subjects treated with salmeterol (39.7% reduction [95% CI: 22.8, 52.9], *P*<0.001) in the first trial and (34.3% reduction [95% CI: 18.6, 47.0], *P*<0.001) in the second trial. Secondary endpoints including pulmonary function and symptom scores improved more in subjects treated with ADVAIR DISKUS 250/50 than with salmeterol 50 mcg in both trials.

Exacerbations were evaluated in the 1- and the 3-year trials with ADVAIR DISKUS 500/50 as 1 of the secondary efficacy endpoints. In the 1-year trial, the group receiving ADVAIR DISKUS 500/50 had a significantly lower rate of moderate and severe exacerbations compared with placebo (25.4% reduction compared with placebo [95% CI: 13.5, 35.7]) but not when compared with its components (7.5% reduction compared with fluticasone propionate [95% CI: -7.3, 20.3] and 7% reduction compared with salmeterol [95% CI: -8.0, 19.9]). In the 3-year trial, the group receiving ADVAIR DISKUS 500/50 had a significantly lower rate of moderate and severe exacerbations compared with each of the other treatment groups (25.1% reduction compared with placebo [95% CI: 18.6, 31.1], 9.0% reduction compared with fluticasone propionate [95% CI: 1.2, 16.2], and 12.2% reduction compared with salmeterol [95% CI: 4.6, 19.2]).

There were no trials conducted to directly compare the efficacy of ADVAIR DISKUS 250/50 with ADVAIR DISKUS 500/50 on exacerbations. Across trials, the reduction in exacerbations seen with ADVAIR DISKUS 500/50 was not greater than the reduction in exacerbations seen with ADVAIR DISKUS 250/50.

Survival

A 3-year multicenter, international trial evaluated the efficacy of ADVAIR DISKUS 500/50 compared with fluticasone propionate 500 mcg, salmeterol 50 mcg, and placebo on survival in 6,112 subjects with COPD. During the trial subjects were permitted usual COPD therapy with the exception of other ICS and long-acting bronchodilators. The subjects were aged 40 to 80 years with an established history of COPD, a pre-bronchodilator FEV₁ <60% of predicted at trial entry, and <10% of predicted reversibility. Each subject who withdrew from double-blind treatment for any reason was followed for the full 3-year trial period to determine survival status. The primary efficacy endpoint was all-cause mortality. Survival with ADVAIR DISKUS 500/50 was not significantly improved compared with placebo or the individual components (all-cause mortality rate 12.6% ADVAIR DISKUS versus 15.2% placebo). The rates for all-cause mortality were 13.5% and 16.0% in the groups treated with salmeterol 50 mcg and fluticasone propionate 500 mcg, respectively. Secondary outcomes, including pulmonary function (post-bronchodilator FEV₁), improved with ADVAIR DISKUS 500/50, salmeterol 50 mcg, and fluticasone propionate 500 mcg compared with placebo.

16 HOW SUPPLIED/STORAGE AND HANDLING

ADVAIR DISKUS 100/50 is supplied as a disposable purple plastic inhaler containing a foil blister strip with 60 blisters. The inhaler is packaged in a plastic-coated, moisture-protective foil pouch (NDC 0173-0695-00). ADVAIR DISKUS 100/50 is also supplied in an institutional pack containing 14 blisters (NDC 0173-0695-04).

ADVAIR DISKUS 250/50 is supplied as a disposable purple plastic inhaler containing a foil blister strip with 60 blisters. The inhaler is packaged in a plastic-coated, moisture-protective foil

pouch (NDC 0173-0696-00). ADVAIR DISKUS 250/50 is also supplied in an institutional pack containing 14 blisters (NDC 0173-0696-04).

ADVAIR DISKUS 500/50 is supplied as a disposable purple plastic inhaler containing a foil blister strip with 60 blisters. The inhaler is packaged in a plastic-coated, moisture-protective foil pouch (NDC 0173-0697-00). ADVAIR DISKUS 500/50 is also supplied in an institutional pack containing 14 blisters (NDC 0173-0697-04).

Store at room temperature between 68°F and 77°F (20°C and 25°C); excursions permitted from 59°F to 86°F (15°C to 30°C) [See USP Controlled Room Temperature]. Store in a dry place away from direct heat or sunlight. Keep out of reach of children.

ADVAIR DISKUS should be stored inside the unopened moisture-protective foil pouch and only removed from the pouch immediately before initial use. Discard ADVAIR DISKUS 1 month after opening the foil pouch or when the counter reads “0” (after all blisters have been used), whichever comes first. The inhaler is not reusable. Do not attempt to take the inhaler apart.

17 PATIENT COUNSELING INFORMATION

Advise the patient to read the FDA-approved patient labeling (Patient Information and Instructions for Use).

Serious Asthma-Related Events

Inform patients with asthma that LABA when used alone increases the risk of asthma-related hospitalization or asthma-related death. Available data show that when ICS and LABA are used together, such as with ADVAIR DISKUS, there is not a significant increase in the risk of these events.

Not for Acute Symptoms

Inform patients that ADVAIR DISKUS is not meant to relieve acute asthma symptoms or exacerbations of COPD and extra doses should not be used for that purpose. Advise patients to treat acute symptoms with an inhaled, short-acting beta₂-agonist such as albuterol. Provide patients with such medication and instruct them in how it should be used.

Instruct patients to seek medical attention immediately if they experience any of the following:

- Decreasing effectiveness of inhaled, short-acting beta₂-agonists
- Need for more inhalations than usual of inhaled, short-acting beta₂-agonists
- Significant decrease in lung function as outlined by the physician

Tell patients they should not stop therapy with ADVAIR DISKUS without physician/provider guidance since symptoms may recur after discontinuation.

Do Not Use Additional Long-acting Beta₂-agonists

Instruct patients not to use other LABA for asthma and COPD.

Local Effects

Inform patients that localized infections with *Candida albicans* occurred in the mouth and pharynx in some patients. If oropharyngeal candidiasis develops, treat it with appropriate local or systemic (i.e., oral) antifungal therapy while still continuing therapy with ADVAIR DISKUS, but at times therapy with ADVAIR DISKUS may need to be temporarily interrupted under close medical supervision. Advise patients to rinse the mouth with water without swallowing after inhalation to help reduce the risk of thrush.

Pneumonia

Patients with COPD have a higher risk of pneumonia; instruct them to contact their healthcare providers if they develop symptoms of pneumonia.

Immunosuppression

Warn patients who are on immunosuppressant doses of corticosteroids to avoid exposure to chickenpox or measles and, if exposed, to consult their physicians without delay. Inform patients of potential worsening of existing tuberculosis; fungal, bacterial, viral, or parasitic infections; or ocular herpes simplex.

Hypercorticism and Adrenal Suppression

Advise patients that ADVAIR DISKUS may cause systemic corticosteroid effects of hypercorticism and adrenal suppression. Additionally, inform patients that deaths due to adrenal insufficiency have occurred during and after transfer from systemic corticosteroids. Patients should taper slowly from systemic corticosteroids if transferring to ADVAIR DISKUS.

Immediate Hypersensitivity Reactions

Advise patients that immediate hypersensitivity reactions (e.g., urticaria, angioedema, rash, bronchospasm, hypotension), including anaphylaxis, may occur after administration of ADVAIR DISKUS. Patients should discontinue ADVAIR DISKUS if such reactions occur. There have been reports of anaphylactic reactions in patients with severe milk protein allergy after inhalation of powder products containing lactose; therefore, patients with severe milk protein allergy should not take ADVAIR DISKUS.

Reduction in Bone Mineral Density

Advise patients who are at an increased risk for decreased BMD that the use of corticosteroids may pose an additional risk.

Reduced Growth Velocity

Inform patients that orally inhaled corticosteroids, including fluticasone propionate, may cause a reduction in growth velocity when administered to pediatric patients. Physicians should closely follow the growth of children and adolescents taking corticosteroids by any route.

Glaucoma and Cataracts

Advise patients that long-term use of ICS may increase the risk of some eye problems (cataracts or glaucoma); consider regular eye examinations.

Risks Associated with Beta-agonist Therapy

Inform patients of adverse effects associated with beta₂-agonists, such as palpitations, chest pain, rapid heart rate, tremor, or nervousness.

Trademarks are owned by or licensed to the GSK group of companies.



GlaxoSmithKline
Research Triangle Park, NC 27709

©Year GSK group of companies or its licensor.

ADD: xxPI

PATIENT INFORMATION

ADVAIR DISKUS (AD vair DISK us) (fluticasone propionate and salmeterol inhalation powder) for oral inhalation use

What is ADVAIR DISKUS?

- ADVAIR DISKUS combines the inhaled corticosteroid (ICS) medicine fluticasone propionate and the long-acting beta₂-adrenergic agonist (LABA) medicine salmeterol.
 - ICS medicines such as fluticasone propionate help to decrease inflammation in the lungs. Inflammation in the lungs can lead to breathing problems.
 - LABA medicines such as salmeterol help the muscles around the airways in your lungs stay relaxed to prevent symptoms, such as wheezing, cough, chest tightness, and shortness of breath. These symptoms can happen when the muscles around the airways tighten. This makes it hard to breathe.
- **ADVAIR DISKUS is not used to relieve sudden breathing problems** and will not replace a rescue inhaler.
- It is not known if ADVAIR DISKUS is safe and effective in children younger than 4 years.
- ADVAIR DISKUS is used for asthma and COPD as follows:

Asthma:

- ADVAIR DISKUS is a prescription medicine used to control symptoms of asthma and to prevent symptoms such as wheezing in adults and children aged 4 years and older.
- ADVAIR DISKUS contains salmeterol, the same medicine found in SEREVENT DISKUS (salmeterol xinafoate inhalation powder). LABA medicines such as salmeterol when used alone increase the risk of hospitalizations and death from asthma problems. ADVAIR DISKUS contains an ICS and a LABA. When an ICS and LABA are used together, there is not a significant increased risk in hospitalizations and death from asthma problems.
- ADVAIR DISKUS is not for adults and children with asthma who are well controlled with an asthma control medicine, such as a low to medium dose of an ICS medicine. ADVAIR DISKUS is for adults and children with asthma who need both an ICS and LABA medicine.

COPD:

ADVAIR DISKUS 250/50 is a prescription medicine used to treat COPD. COPD is a chronic lung disease that includes chronic bronchitis, emphysema, or both. ADVAIR DISKUS 250/50 is used long term as 1 inhalation 2 times each day to improve symptoms of COPD for better breathing and to reduce the number of flare-ups (the worsening of your COPD symptoms for several days).

Do not use ADVAIR DISKUS:

- to relieve sudden breathing problems.
- as a rescue inhaler.
- if you have a severe allergy to milk proteins. Ask your healthcare provider if you are not sure.
- if you are allergic to fluticasone propionate, salmeterol, or any of the ingredients in ADVAIR DISKUS. See the end of this Patient Information for a complete list of ingredients in ADVAIR DISKUS.

Before using ADVAIR DISKUS, tell your healthcare provider about all of your medical conditions, including if you:

- have heart problems.
- have high blood pressure.

- have seizures.
- have thyroid problems.
- have diabetes.
- have liver problems.
- have weak bones (osteoporosis).
- have an immune system problem.
- have or have had eye problems such as glaucoma, increased pressure in your eye, cataracts, or other changes in vision.
- are allergic to milk proteins.
- have any type of viral, bacterial, or fungal infection.
- are exposed to chickenpox or measles.
- are pregnant or plan to become pregnant. It is not known if ADVAIR DISKUS may harm your unborn baby.
- are breastfeeding. It is not known if the medicines in ADVAIR DISKUS pass into your milk and if they can harm your baby.

Tell your healthcare provider about all the medicines you take, including prescription and over-the-counter medicines, vitamins, and herbal supplements. ADVAIR DISKUS and certain other medicines may interact with each other. This may cause serious side effects. Especially tell your healthcare provider if you take antifungal or anti-HIV medicines. Know the medicines you take. Keep a list of them to show your healthcare provider and pharmacist when you get a new medicine.

How should I use ADVAIR DISKUS?

Read the step-by-step instructions for using ADVAIR DISKUS at the end of this Patient Information.

- **Do not** use ADVAIR DISKUS unless your healthcare provider has taught you how to use the inhaler and you understand how to use it correctly.
- Children should use ADVAIR DISKUS with an adult's help, as instructed by the child's healthcare provider.
- ADVAIR DISKUS comes in 3 different strengths. Your healthcare provider prescribed the strength that is best for you.
- Use ADVAIR DISKUS exactly as your healthcare provider tells you to use it. **Do not** use ADVAIR DISKUS more often than prescribed.
- Use 1 inhalation of ADVAIR DISKUS 2 times each day. Use ADVAIR DISKUS at the same time each day, about 12 hours apart.
- If you miss a dose of ADVAIR DISKUS, just skip that dose. Take your next dose at your usual time. Do not take 2 doses at 1 time.
- If you take too much ADVAIR DISKUS, call your healthcare provider or go to the nearest hospital emergency room right away if you have any unusual symptoms, such as worsening shortness of breath, chest pain, increased heart rate, or shakiness.
- **Do not use other medicines that contain a LABA for any reason.** Ask your healthcare provider or pharmacist if any of your other medicines are LABA medicines.
- **Do not** stop using ADVAIR DISKUS, even if you are feeling better, unless your healthcare provider tells you to.
- **ADVAIR DISKUS does not relieve sudden breathing problems.** Always have a rescue inhaler with you to treat sudden symptoms. If you do not have a rescue inhaler, call your healthcare provider to have one prescribed for you.
- Rinse your mouth with water **without swallowing** after each dose of ADVAIR DISKUS. This will help lessen the

chance of getting a yeast infection (thrush) in your mouth and throat.

- Call your healthcare provider or get medical care right away if:
 - your breathing problems get worse.
 - you need to use your rescue inhaler more often than usual.
 - your rescue inhaler does not work as well to relieve your symptoms.
 - you need to use 4 or more inhalations of your rescue inhaler in 24 hours for 2 or more days in a row.
 - you use 1 whole canister of your rescue inhaler in 8 weeks.
 - your peak flow meter results decrease. Your healthcare provider will tell you the numbers that are right for you.
 - you have asthma and your symptoms do not improve after using ADVAIR DISKUS regularly for 1 week.

What are the possible side effects of ADVAIR DISKUS?

ADVAIR DISKUS can cause serious side effects, including:

- **fungal infection in your mouth or throat (thrush).** Rinse your mouth with water **without swallowing** after using ADVAIR DISKUS to help reduce your chance of getting thrush.
- **pneumonia.** People with COPD have a higher chance of getting pneumonia. ADVAIR DISKUS may increase the chance of you getting pneumonia. Call your healthcare provider right away if you have any of the following symptoms:
 - increase in mucus (sputum) production
 - change in mucus color
 - fever
 - chills
 - increased cough
 - increased breathing problems
- **weakened immune system and increased chance of getting infections (immunosuppression).**
- **reduced adrenal function (adrenal insufficiency).** Adrenal insufficiency is a condition where the adrenal glands do not make enough steroid hormones. This can happen when you stop taking oral corticosteroid medicines (such as prednisone) and start taking a medicine containing an inhaled steroid (such as ADVAIR DISKUS). During this transition period, when your body is under stress such as from fever, trauma (such as a car accident), infection, surgery, or worse COPD symptoms, adrenal insufficiency can get worse and may cause death.
Symptoms of adrenal insufficiency include:
 - feeling tired
 - lack of energy
 - weakness
 - nausea and vomiting
 - low blood pressure (hypotension)
- **sudden breathing problems immediately after inhaling your medicine.** If you have sudden breathing problems immediately after inhaling your medicine, stop using ADVAIR DISKUS and call your healthcare provider right away.
- **serious allergic reactions.** Call your healthcare provider or get emergency medical care if you get any of the following symptoms of a serious allergic reaction:
 - rash
 - hives
 - swelling of your face, mouth, and tongue
 - breathing problems
- **effects on heart.**
 - increased blood pressure
 - a fast or irregular heartbeat
 - chest pain
- **effects on nervous system.**
 - tremor
 - nervousness
- **bone thinning or weakness (osteoporosis).**

- **slowed growth in children.** Your child's growth should be checked regularly by the healthcare provider while using ADVAIR DISKUS.
- **eye problems** including glaucoma, increased pressure in your eye, cataracts, or other changes in vision. You should have regular eye exams while using ADVAIR DISKUS.
- **changes in laboratory blood levels (sugar, potassium, certain types of white blood cells).**

Common side effects of ADVAIR DISKUS include:

Asthma:

- | | |
|--|-----------------------|
| • upper respiratory tract infection | • bronchitis |
| • throat irritation | • cough |
| • hoarseness and voice changes | • headache |
| • thrush in your mouth or throat. Rinse your mouth with water without swallowing after use to help prevent this. | • nausea and vomiting |

In children with asthma, infections in the ear, nose, and throat are common.

COPD:

- | | |
|--|--------------------------------|
| • thrush in your mouth or throat. Rinse your mouth with water without swallowing after use to help prevent this. | • viral respiratory infections |
| • throat irritation | • headache |
| • hoarseness and voice changes | • muscle and bone pain |

These are not all the possible side effects of ADVAIR DISKUS.

Call your doctor for medical advice about side effects. You may report side effects to FDA at 1-800-FDA-1088.

How should I store ADVAIR DISKUS?

- Store ADVAIR DISKUS at room temperature between 68°F and 77°F (20°C and 25°C). Keep in a dry place away from heat and sunlight.
- Store ADVAIR DISKUS in the unopened foil pouch and only open when ready for use.
- Safely throw away ADVAIR DISKUS in the trash 1 month after you open the foil pouch or when the counter reads **0**, whichever comes first.

Keep ADVAIR DISKUS and all medicines out of the reach of children.

General information about the safe and effective use of ADVAIR DISKUS.

Medicines are sometimes prescribed for purposes other than those listed in a Patient Information leaflet. Do not use ADVAIR DISKUS for a condition for which it was not prescribed. Do not give ADVAIR DISKUS to other people, even if they have the same symptoms that you have. It may harm them.

You can ask your healthcare provider or pharmacist for information about ADVAIR DISKUS that was written for health professionals.

What are the ingredients in ADVAIR DISKUS?

Active ingredients: fluticasone propionate, salmeterol xinafoate

Inactive ingredient: lactose monohydrate (contains milk proteins)



For more information about ADVAIR DISKUS, call 1-888-825-5249 or visit our website at www.advair.com.

Trademarks are owned by or licensed to the GSK group of companies.

GlaxoSmithKline, Research Triangle Park, NC 27709

©Year GSK group of companies or its licensor.

INSTRUCTIONS FOR USE
ADVAIR DISKUS (AD vair DISK us)
(fluticasone propionate and salmeterol inhalation powder)
for oral inhalation use

Read this Instructions for Use before you start using ADVAIR DISKUS and each time you get a refill. There may be new information. This information does not take the place of talking to your healthcare provider about your medical condition or treatment.

Your ADVAIR DISKUS inhaler



Figure A

Important information about your ADVAIR DISKUS inhaler:

- **ADVAIR DISKUS is for oral inhalation use only.**
- Take ADVAIR DISKUS out of the foil pouch just before you use it for the first time. Safely throw away the pouch. The DISKUS will be in the closed position.
- Write the date you opened the foil pouch in the first blank line on the label. **See Figure A.**
- Write the “use by” date in the second blank line on the label. **See Figure A.** That date is 1 month after the date you wrote in the first line.
- The counter should read **60**. If you have a sample (with “Sample” on the back label) or institutional (with “INSTITUTIONAL PACK” on the back label) pack, the counter should read **14**.

How to use your ADVAIR DISKUS inhaler

Follow these steps every time you use ADVAIR DISKUS.

Step 1. Open your ADVAIR DISKUS.

- Hold the DISKUS in your left hand and place the thumb of your right hand in the thumb grip. Push the thumb grip away from you as far as it will go until the mouthpiece shows and snaps into place. **See Figure B.**

Step 2. Slide the lever until you hear it click.

- **Hold the DISKUS in a level, flat position** with the mouthpiece towards you. Slide the lever away from the mouthpiece as far as it will go until it **clicks**. **See Figure C.**



Figure B



Figure C

- The number on the counter will count down by 1. The DISKUS is now ready to use.

Follow the instructions below so you will not accidentally waste a dose:

- **Do not** close the DISKUS.
- **Do not** tilt the DISKUS.
- **Do not** move the lever on the DISKUS.

Step 3. Inhale your medicine.

- Before you breathe in your dose from the DISKUS, breathe out (exhale) as long as you can while you hold the DISKUS level and away from your mouth. **See Figure D.** Do not breathe into the mouthpiece.
- Put the mouthpiece to your lips. **See Figure E.** Breathe in quickly and deeply through the DISKUS. Do not breathe in through your nose.



Figure D



Figure E

- Remove the DISKUS from your mouth **and hold your breath for about 10 seconds**, or for as long as is comfortable for you.
- **Breathe out slowly as long as you can. See Figure D.**
- The DISKUS delivers your dose of medicine as a very fine powder that you may or may not taste or feel. **Do not** take an extra dose from the DISKUS even if you do not taste or feel the medicine.

Step 4. Close the DISKUS.

- Place your thumb in the thumb grip and slide it back towards you as far as it will go. **See Figure F.** Make sure the DISKUS clicks shut and you cannot see the mouthpiece.



Figure F

- The DISKUS is now ready for you to take your next scheduled dose in about 12 hours. **When you are ready to take your next dose, repeat Steps 1 through 4.**

Step 5. Rinse your mouth.

- **Rinse your mouth with water after breathing in the medicine.** Spit out the water. Do not swallow it. **See Figure G.**



Figure G

When should you get a refill?

The counter on top of the DISKUS shows you how many doses are left. After you have taken **55** doses (**9** doses from the sample or institutional pack), the numbers **5** to **0** will show in red. **See Figure H.**

These numbers warn you there are only a few doses left and are a reminder to get a refill.



Figure H

For correct use of the DISKUS, remember:

- Always use the DISKUS in a level, flat position.
- Make sure the lever firmly clicks into place.
- Hold your breath for about 10 seconds after inhaling. Then breathe out fully.
- After each dose, rinse your mouth with water and spit it out. Do not swallow the water.
- **Do not** take an extra dose, even if you did not taste or feel the powder.
- **Do not** take the DISKUS apart.
- **Do not** wash the DISKUS.
- Always keep the DISKUS in a dry place.
- **Do not** use the DISKUS with a spacer device.



For more information about ADVAIR DISKUS or how to use your inhaler, call 1-888-825-5249 or visit our website at www.advair.com.

Trademarks are owned by or licensed to the GSK group of companies.

GlaxoSmithKline, Research Triangle Park, NC 27709

©Year GSK group of companies or its licensor.

ADD:xIFU

This Instructions for Use has been approved by the U.S. Food and Drug Administration

Revised: January 2019

PrADVAIR DISKUS

fluticasone propionate and salmeterol inhalation powder USP

PrADVAIR DISKUS 100

100 mcg fluticasone propionate and 50 mcg salmeterol (as the xinafoate salt)

PrADVAIR DISKUS 250

250 mcg fluticasone propionate and 50 mcg salmeterol (as the xinafoate salt)

PrADVAIR DISKUS 500

500 mcg fluticasone propionate and 50 mcg salmeterol (as the xinafoate salt)

PrADVAIR

fluticasone propionate and salmeterol pressurised inhalation, suspension BP

PrADVAIR 125

125 mcg fluticasone propionate and 25 mcg salmeterol (as the xinafoate salt)

PrADVAIR 250

250 mcg fluticasone propionate and 25 mcg salmeterol (as the xinafoate salt)

Corticosteroid and Bronchodilator for Oral Inhalation

GlaxoSmithKline Inc.
7333 Mississauga Road
Mississauga, Ontario
L5N 6L4

Date of Revision:
June 17, 2020

Submission Control No: 237271

© 2020 GSK group of companies or its licensor
Trademarks are owned by or licensed to the GSK group of companies.

Table of Contents

PART I: HEALTH PROFESSIONAL INFORMATION	3
SUMMARY PRODUCT INFORMATION	3
INDICATIONS AND CLINICAL USE.....	3
CONTRAINDICATIONS	4
WARNINGS AND PRECAUTIONS	4
ADVERSE REACTIONS	15
DRUG INTERACTIONS	24
DOSAGE AND ADMINISTRATION.....	27
OVERDOSAGE	29
ACTION AND CLINICAL PHARMACOLOGY	30
STORAGE AND STABILITY	32
SPECIAL HANDLING INSTRUCTIONS	33
DOSAGE FORMS, COMPOSITION AND PACKAGING	33
PART II: SCIENTIFIC INFORMATION	35
PHARMACEUTICAL INFORMATION	35
CLINICAL TRIALS	37
DETAILED PHARMACOLOGY	46
TOXICOLOGY	49
REFERENCES	53
PART III: CONSUMER INFORMATION.....	55
PART III: CONSUMER INFORMATION.....	63

PrADVAIR DISKUS

fluticasone propionate and salmeterol inhalation powder USP

PrADVAIR

fluticasone propionate and salmeterol pressurised inhalation, suspension BP

PART I: HEALTH PROFESSIONAL INFORMATION

SUMMARY PRODUCT INFORMATION

Route of Administration	Dosage Form / Strength	Nonmedicinal Ingredients
Oral Inhalation	Inhalation Powder/ 100, 250, 500 mcg fluticasone propionate/ 50 mcg salmeterol/blister	Lactose and milk protein
Oral Inhalation	Pressurised Inhalation, Suspension/ 125, 250 mcg fluticasone propionate/ 25 mcg salmeterol/ metered dose	1,1,1,2-tetrafluoroethane (HFA-134a)

INDICATIONS AND CLINICAL USE

Asthma

ADVAIR/ADVAIR DISKUS (fluticasone propionate/salmeterol) is a combination of an inhaled corticosteroid (ICS) and a long-acting beta₂-adrenergic agonist (LABA) indicated for the maintenance treatment of asthma, in patients with reversible obstructive airways disease.

ADVAIR/ADVAIR DISKUS should be prescribed for patients not adequately controlled on a long-term asthma control medication, such as an ICS, or whose disease severity clearly warrants treatment with both an ICS and a LABA.

ADVAIR/ADVAIR DISKUS is **not** indicated for patients whose asthma can be managed by occasional use of a rapid onset, short duration, inhaled beta₂-agonist, or for patients whose asthma can be successfully managed by inhaled corticosteroids along with occasional use of a rapid onset, short duration, inhaled beta₂-agonist.

ADVAIR/ADVAIR DISKUS should **not** be used as a rescue medication. To relieve acute asthmatic symptoms, a rapid onset, short duration inhaled bronchodilator (e.g. salbutamol) should be used.

Chronic Obstructive Pulmonary Disease (COPD)

ADVAIR DISKUS 250 and ADVAIR DISKUS 500 are indicated for:

- the maintenance treatment of COPD, including emphysema and chronic bronchitis, in patients where the use of a combination product is considered appropriate.

ADVAIR DISKUS should **not** be used as a rescue medication.

Physicians should reassess patients several months after the initiation of ADVAIR DISKUS and if symptomatic improvement has not occurred, ADVAIR DISKUS should be discontinued.

Geriatrics:

There is no need to adjust the dose in elderly patients.

Pediatrics (< 4 years of age):

At present, there is insufficient clinical data to recommend the use of ADVAIR DISKUS in children younger than 4 years of age and the use of ADVAIR pressurised inhalation, suspension in children younger than 12 years of age.

CONTRAINDICATIONS

- Patients who are hypersensitive to this drug or to any ingredient in the formulation or component of the container. For a complete listing, see DOSAGE FORMS, COMPOSITION AND PACKAGING.
- Patients with IgE mediated allergic reactions to lactose (which contains milk protein) or milk (ADVAIR DISKUS users only).
- Patients with cardiac tachyarrhythmias.
- Patients with untreated fungal, bacterial or tuberculous infections of the respiratory tract.
- In the primary treatment of status asthmaticus or other acute episodes of asthma.

WARNINGS AND PRECAUTIONS

General

Serious Asthma-Related Events – Hospitalizations, Intubations, Death

Use of LABA as monotherapy (without ICS) for asthma is associated with an increased risk of asthma-related death (see Salmeterol Multicenter Asthma Research Trial (SMART)). Available data from controlled clinical trials also suggest that use of LABA

as monotherapy increases the risk of asthma-related hospitalization in pediatric and adolescent patients. These findings are considered a class effect of LABA monotherapy.

When LABA are used in fixed-dose combination with ICS, data from large clinical trials do not show a significant increase in the risk of serious asthma-related events (hospitalizations, intubations, death) compared with ICS alone (see Serious Asthma-Related Events with Inhaled Corticosteroid/Long-acting Beta₂-adrenergic Agonist Combination Products).

Serious Asthma-Related Events with Inhaled Corticosteroid/Long-acting Beta₂-adrenergic Agonist Combination Products

Four (4) large, 26-week, randomized, double-blind, active-controlled clinical safety trials were conducted to evaluate the risk of serious asthma-related events when LABA were used in fixed-dose combination with ICS compared with ICS alone in subjects with asthma. Three (3) trials included adult and adolescent subjects aged 12 years and older: 1 trial compared budesonide/formoterol with budesonide, 1 trial compared fluticasone propionate/salmeterol with fluticasone propionate (see CLINICAL TRIALS), and 1 trial compared mometasone furoate/formoterol with mometasone furoate. The fourth trial included pediatric subjects aged 4 to 11 years and compared fluticasone propionate/salmeterol with fluticasone propionate (see CLINICAL TRIALS). The primary safety endpoint for all 4 trials was serious asthma-related events (hospitalizations, intubations, death). A single, blinded, independent, joint adjudication committee determined whether events were asthma related.

The 3 adult and adolescent trials were designed to rule out a 2.0-fold increase in relative risk for ICS/LABA compared with ICS, and the pediatric trial was designed to rule out a 2.7-fold increase in this relative risk. Each individual trial met its pre-specified objective and demonstrated non-inferiority of ICS/LABA to ICS alone. A meta-analysis of the 3 adult and adolescent trials did not show a significant increase in risk of a serious asthma-related event with ICS/LABA fixed-dose combination compared with ICS alone (Table 1). These trials were not designed to rule out all risk for serious asthma-related events with ICS/LABA compared with ICS.

Table 1 Meta-analysis of Serious Asthma-Related Events in Subjects with Asthma Aged 12 Years and Older

	ICS/LABA (n=17,537)^a	ICS (n=17,552)^a	ICS/LABA vs. ICS Hazard Ratio (95% CI)^b
Serious asthma-related event ^c	116	105	1.10 (0.85, 1.44)
Asthma-related death	2	0	
Asthma-related intubation (endotracheal)	1	2	
Asthma-related hospitalization (≥24-hour stay)	115	105	

ICS = Inhaled Corticosteroid; LABA = Long-acting Beta₂-adrenergic Agonist.

^a Randomized subjects who had taken at least 1 dose of study drug. Planned treatment used for analysis.

^b Estimated using a Cox proportional hazards model for time to first event with baseline hazards stratified by each of the 3 trials.

^c Number of subjects with an event that occurred within 6 months after the first use of study drug or 7 days after the last date of study drug, whichever date was later. Subjects may have had one or more events, but only the first event was counted for analysis. A single, blinded, independent joint adjudication committee determined whether events were asthma related.

The pediatric safety trial included 6,208 pediatric subjects aged 4 to 11 years who received ICS/LABA (fluticasone propionate/salmeterol inhalation powder) or ICS (fluticasone propionate inhalation powder). In this trial, 27/3,107 (0.9%) subjects randomized to ICS/LABA and 21/3,101 (0.7%) subjects randomized to ICS experienced a serious asthma-related event. There were no asthma-related deaths or intubations. ICS/LABA did not show a significant increase in risk of a serious asthma-related event compared with ICS based on the pre-specified risk margin (2.7), with an estimated hazard ratio of time to first event of 1.29 (95% CI: 0.73, 2.27).

Salmeterol Multicenter Asthma Research Trial (SMART)

A 28-week, placebo-controlled, U.S. trial that compared the safety of salmeterol with placebo, each added to usual asthma therapy, showed an increase in asthma-related deaths in subjects receiving salmeterol (13/13,176 in subjects treated with salmeterol versus 3/13,179 in subjects treated with placebo; relative risk: 4.37 [95% CI: 1.25, 15.34]). Use of background ICS was not required in SMART. The increased risk of asthma-related death is considered a class effect of LABA monotherapy.

Not for Acute Use

ADVAIR/ADVAIR DISKUS should not be used to treat acute symptoms of asthma or COPD. It is crucial to inform patients of this and prescribe rapid onset, short duration inhaled bronchodilator (e.g., salbutamol) to relieve the acute symptoms of asthma or COPD. Patients should be clearly instructed to use rapid onset, short duration, inhaled beta₂-agonists only for symptomatic relief if they develop asthma or COPD symptoms while taking ADVAIR/ADVAIR DISKUS.

When beginning treatment with ADVAIR/ADVAIR DISKUS, patients who have been taking rapid onset, short duration, inhaled beta₂-agonists on a regular basis (e.g., q.i.d)

should be instructed to discontinue the regular use of these drugs and use them only for symptomatic relief if they develop acute symptoms of asthma or COPD while taking ADVAIR/ADVAIR DISKUS.

Excessive Use and Use with Other LABA Products

ADVAIR/ADVAIR DISKUS should not be used more often than recommended, at higher doses than recommended, or in conjunction with other medicines containing LABA, as an overdose may result. Clinically significant cardiovascular effects and fatalities have been reported in association with excessive use of inhaled sympathomimetic drugs. Patients using ADVAIR/ADVAIR DISKUS should not use another medicine containing a LABA (e.g. formoterol fumarate, indacaterol, olodaterol, vilanterol) for any reason.

Discontinuance

Treatment with inhaled corticosteroids should not be stopped abruptly in patients with asthma due to risk of exacerbation. In this case, therapy should be titrated down gradually, under physician supervision. For patients with COPD, cessation of therapy may be associated with symptomatic decompensation and should be supervised by a physician.

Cardiovascular Effects

Pharmacological side-effects of beta-2 agonist treatment, such as palpitations have been reported, but tend to be transient and to reduce with regular therapy (see ADVERSE REACTIONS). A small increase in QTc interval has been reported with therapeutic doses of salmeterol. Cardiovascular effects such as increased blood pressure and heart rate may occasionally be seen with all sympathomimetic drugs, especially at higher than therapeutic doses.

Large doses of inhaled or oral salmeterol (12 to 20 times the recommended dose) have been associated with clinically significant prolongation of the QTc interval, which has the potential for producing ventricular arrhythmias. Fatalities have been reported following excessive use of aerosol preparations containing sympathomimetic amines, the exact cause of which is unknown. Cardiac arrest was reported in several instances.

In individual patients any beta₂-adrenergic agonist may have a clinically significant cardiac effect. As has been described with other beta-adrenergic agonist bronchodilators, clinically significant changes in systolic and/or diastolic blood pressure, pulse rate, and electrocardiograms have been seen infrequently in individual patients in controlled clinical studies with salmeterol.

Fluticasone propionate/salmeterol xinafoate, like all products, containing sympathomimetic amines, should be used with caution in patients with cardiovascular disorders, especially coronary insufficiency, cardiac arrhythmias, and hypertension; in patients with convulsive disorders or thyrotoxicosis; and in patients who are unusually responsive to sympathomimetic amines.

Occurrence of cardiovascular effects may require discontinuation of the drug.

Central Nervous System Effects

Central nervous system effects of beta₂-agonist treatment such as tremor and headache have been reported, but tend to be transient and to reduce with regular therapy. Other central nervous system effects of beta₂-agonist treatment, such as situational disorders, agitation, anxiety, irritability, sleep disorders, syncope, vertigo or dizziness can occur after the use of ADVAIR/ADVAIR DISKUS.

Ear/Nose/Throat

Symptoms of laryngeal spasm, irritation, or swelling, such as stridor and choking, have been reported rarely in patients receiving salmeterol.

Also see Immune, Candidiasis.

Endocrine And Metabolism

Systemic Steroid Replacement by Inhaled Steroid

Particular care is needed in patients who are transferred from systemically active corticosteroids to inhaled corticosteroids because deaths due to adrenal insufficiency have occurred in patients with asthma during and after transfer. For the transfer of patients being treated with oral corticosteroids, inhaled corticosteroids should first be added to the existing oral steroid therapy which is then gradually withdrawn.

Patients with adrenocortical suppression should be monitored regularly and the oral steroid reduced cautiously. Some patients transferred from other inhaled steroids or oral steroids remain at risk of impaired adrenal reserve for a considerable time after transferring to inhaled fluticasone propionate.

After withdrawal from systemic corticosteroids, a number of months are required for recovery of hypothalamic-pituitary-adrenal (HPA) function. During this period of HPA suppression, patients may exhibit signs and symptoms of adrenal insufficiency when exposed to trauma, surgery or infections, particularly gastroenteritis. Although inhaled fluticasone propionate may provide control of asthmatic symptoms during these episodes, it does not provide the systemic steroid which is necessary for coping with these emergencies. The physician may consider supplying oral steroids for use in times of stress (e.g. worsening asthma attacks, chest infections, and surgery).

During periods of stress or a severe asthmatic attack, patients who have been withdrawn from systemic corticosteroids should be instructed to resume systemic steroids immediately and to contact their physician for further instruction. These patients should also be instructed to carry a warning card indicating that they may need supplementary systemic steroids during periods of stress or a severe asthma attack. To assess the risk of adrenal insufficiency in emergency situations, routine tests of adrenal cortical function, including measurement of early morning and evening cortisol levels, should be performed periodically in all patients. An early morning resting cortisol level may be accepted as normal only if it falls at or near the normal mean level.

Systemic Effects

Systemic effects may occur with any inhaled corticosteroid, particularly at high doses prescribed for long periods; these effects are much less likely to occur than with oral corticosteroids. Possible systemic effects include Cushing's syndrome, Cushingoid features, and adrenal suppression, growth retardation in children and adolescents, decrease in bone mineral density (BMD), cataract, glaucoma and central serous chorioretinopathy. It is important therefore, that the dose of inhaled corticosteroid is titrated to the lowest dose at which effective control is maintained (see Monitoring and Laboratory Tests).

Effects on Growth

A reduction of growth velocity in children or teenagers may occur as a result of inadequate control of chronic diseases such as asthma or from use of corticosteroids for treatment. Physicians should closely follow the growth of children and adolescents taking corticosteroids by any route and weigh the benefits of corticosteroid therapy and asthma control against the possibility of growth suppression if any child's or adolescent's growth appears slowed.

The long-term effects of fluticasone propionate in human subjects are still unknown. The local effect of the drug on developmental or immunologic processes in the mouth, pharynx, trachea, and lungs is unknown. There is also no information about the possible long-term systemic effects of the agent (see Monitoring and Laboratory Tests).

Bone Metabolism

Long-term use of orally inhaled corticosteroids may affect normal bone metabolism resulting in a loss of bone mineral density. In patients with major risk factors for decreased bone mineral content, such as chronic alcohol use, tobacco use, age, sedentary lifestyle, strong family history of osteoporosis, or chronic use of drugs that can reduce bone mass (e.g., anticonvulsants and corticosteroids), ADVAIR/ADVAIR DISKUS may pose an additional risk.

Effects of treatment with ADVAIR DISKUS 500/50 mcg, fluticasone propionate 500 mcg, salmeterol 50 mcg, or placebo on BMD was evaluated in a subset of 658 patients (females and males 40 to 80 years of age) with COPD in a 3 year study (SCO30003). BMD evaluations were conducted at baseline and at 48, 108 and 158 weeks. There were no significant differences between any of the treatment groups at 3 years. A slight reduction in BMD measured at the hip was observed in all treatment groups (ADVAIR DISKUS -3.2%, fluticasone propionate -2.9%, salmeterol -1.7%, placebo -3.1%). Fracture risk was estimated for the entire population of patients with COPD in study SCO30003 (N = 6,184). There were no significant differences between any of the treatment groups. The probability of a fracture over 3 years was 6.3% for ADVAIR DISKUS, 5.4% for fluticasone propionate, 5.1% for salmeterol, and 5.1% for placebo.

Osteoporosis and fracture are the major complications of long-term treatment with parenteral or oral steroids. Inhaled corticosteroid therapy is also associated with dose-dependent bone loss although the degree of risk is very much less than with oral steroid.

This risk may be offset by titrating the daily dose of inhaled steroid to the minimum required to maintain optimal control of respiratory symptoms. It is not yet known whether the peak bone density achieved during youth is adversely affected if substantial amounts of inhaled corticosteroid are administered prior to 30 years of age. Failure to achieve maximal bone density during youth could increase the risk of osteoporotic fracture when those individuals reach 60 years of age and older.

During post-marketing use, there have been reports of clinically significant drug interactions in patients receiving intranasal or inhaled fluticasone propionate and ritonavir, resulting in systemic corticosteroid effects including Cushing's syndrome and adrenal suppression. Therefore, concomitant use of fluticasone propionate and ritonavir should be avoided, unless the potential benefit to the patient outweighs the risk of systemic corticosteroid side-effects (see DRUG INTERACTIONS).

The results of a drug interaction study conducted in healthy subjects indicated that concomitant use of systemic ketoconazole [a strong cytochrome P450 3A4 (CYP3A4) inhibitor] increased exposure to salmeterol in some subjects. This increase in plasma salmeterol exposure may lead to prolongation in the QTc interval. Due to the potential increased risk of cardiovascular adverse events, the concomitant use of salmeterol with ketoconazole is not recommended (see DRUG INTERACTIONS, and ACTION AND CLINICAL PHARMACOLOGY: Pharmacokinetics). Caution should also be exercised when other CYP3A4 inhibitors are co-administered with salmeterol (e.g. ritonavir, atazanavir, clarithromycin, indinavir, itraconazole, nefazodone, nelfinavir, saquinavir, telithromycin, cobicistat-containing products).

Metabolic Effects

Doses of the related beta₂-adrenoceptor agonist salbutamol, when administered intravenously, have been reported to aggravate pre-existing diabetes mellitus and ketoacidosis. Administration of beta₂-adrenoceptor agonists may cause a decrease in serum potassium, possibly through intracellular shunting, which has the potential to increase the likelihood of arrhythmias. The effect is usually seen at higher therapeutic doses and the decrease is usually transient, not requiring supplementation. Therefore, fluticasone propionate/salmeterol xinafoate should be used with caution in patients predisposed to low levels of serum potassium.

The possibility of impaired adrenal response should always be borne in mind in emergency and elective situations likely to produce stress and appropriate corticosteroid treatment must be considered.

Certain individuals can show greater susceptibility to the effects of inhaled corticosteroid than do most patients.

Similar to other beta-adrenergic agents, salmeterol can induce reversible metabolic changes (hyperglycemia, hypokalemia). Reports of hyperglycemia have been uncommon and this should be considered when prescribing to patients with a history of diabetes mellitus.

There is an enhanced effect of corticosteroids on patients with hypothyroidism.

Hematologic

Eosinophilic Conditions

In rare cases, patients on inhaled fluticasone propionate may present with systemic eosinophilic conditions, with some patients presenting with clinical features of vasculitis consistent with eosinophilic granulomatosis with polyangiitis (EGPA) (formerly Churg-Strauss syndrome), a condition that is often treated with systemic corticosteroid therapy. These events usually, but not always, have been associated with the reduction and/or withdrawal of oral corticosteroid therapy following the introduction of fluticasone propionate. Cases of serious eosinophilic conditions have also been reported with other inhaled corticosteroids in this clinical setting. Physicians should be alerted to eosinophilia, vasculitic rash, worsening pulmonary symptoms, cardiac complications, and/or neuropathy presenting in their patients. A causal relationship between fluticasone propionate and these underlying conditions has not been established.

Hepatic/Biliary/Pancreatic

There is an enhanced effect of corticosteroids on patients with cirrhosis.

Hypersensitivity

Immediate hypersensitivity reactions may occur after administration of salmeterol, as demonstrated by rare cases of urticaria, angioedema, rash and bronchospasm, and very rare cases of anaphylactic reactions, anaphylactic shock.

Immune

Candidiasis

Therapeutic dosages of fluticasone propionate frequently cause the appearance of Candida albicans (thrush) in the mouth and throat. The development of pharyngeal and laryngeal candidiasis is a cause for concern because the extent of its penetration into the respiratory tract is unknown. Patients may find it helpful to rinse the mouth and gargle with water after using ADVAIR/ADVAIR DISKUS. Symptomatic candidiasis can be treated with topical anti-fungal therapy while continuing to use ADVAIR/ADVAIR DISKUS.

Infection

Corticosteroids may mask some signs of infection and new infections may appear. A decreased resistance to localised infection has been observed during corticosteroid therapy. This may require treatment with appropriate therapy or stopping the administration of fluticasone propionate until the infection is eradicated. Patients who are on drugs that suppress the immune system are more susceptible to infections than healthy individuals. Chickenpox and measles, for example, can have a more serious or even fatal course in susceptible children or adults on corticosteroids. In such children or adults who have not had these diseases, particular care should be taken to avoid exposure. How the dose, route, and duration of corticosteroid administration affect the risk of developing a disseminated infection is not known. The contribution of the underlying

disease and/or prior corticosteroid treatment to the risk is also not known. If exposed to chickenpox, prophylaxis with varicella zoster immune globulin (VZIG) may be indicated. If exposed to measles, prophylaxis with intramuscular pooled immunoglobulin (IG) may be indicated. If chickenpox develops, treatment with antiviral agents may be considered.

Ophthalmologic

Glaucoma, increased intraocular pressure, and cataracts have been reported in patients following the long-term administration of inhaled corticosteroids. Long-term administration of inhaled corticosteroids may result in central serous chorioretinopathy (CSCR). For patients at risk, monitoring of ocular effects (cataract, glaucoma, and CSCR) should also be considered in patients receiving maintenance therapy with ADVAIR/ADVAIR DISKUS.

Reports of glaucoma have been rare but may be exacerbated by inhaled corticosteroid treatment. In patients with established glaucoma who require long-term inhaled corticosteroid treatment, it is prudent to measure intraocular pressure before commencing the inhaled corticosteroid and to monitor it subsequently. In patients without established glaucoma, but with a potential for developing intraocular hypertension (e.g. the elderly), intraocular pressure should be monitored at appropriate intervals.

Reports of cataracts have been uncommon. In elderly patients treated with inhaled corticosteroids, the prevalence of posterior subcapsular and nuclear cataracts is probably low but increases in relation to the daily and cumulative lifetime dose. Cofactors such as smoking, ultraviolet B exposure, or diabetes may increase the risk. Children may be less susceptible.

Effects of treatment with ADVAIR DISKUS 500/50 mcg, fluticasone propionate 500 mcg, salmeterol 50 mcg, or placebo on development of cataracts or glaucoma was evaluated in a subset of 658 patients with COPD in a 3 year (SCO30003) study. Ophthalmic examinations were conducted at baseline and at 48, 108 and 158 weeks. The presence of cataracts and glaucoma at baseline was similar across treatment groups (61% to 71% and 5% to 8%, respectively). New cataracts were diagnosed in all treatment groups (26% on ADVAIR DISKUS 500/50 mcg, 17% on fluticasone propionate, 15% on salmeterol, and 21% on placebo). A few new cases of glaucoma were diagnosed (2% on ADVAIR DISKUS 500/50 mcg, 5% on fluticasone propionate, none on salmeterol, and 2% on placebo). There were no significant differences in the development of glaucoma or cataracts between any of the treatment groups.

Respiratory

Paradoxical Bronchospasm

As with other inhalation therapy, paradoxical bronchospasm, characterized by an immediate increase in wheezing after dosing, may occur with ADVAIR/ADVAIR DISKUS. This should be treated immediately with a rapid onset, short duration inhaled bronchodilator (e.g. salbutamol) to relieve acute asthmatic symptoms.

ADVAIR/ADVAIR DISKUS should be discontinued immediately, the patient assessed, and if necessary, alternative therapy instituted.

Pneumonia (COPD Patients)

In a 3 year study of 6,184 patients with COPD (SCO30003) there was an increased reporting of any adverse event of pneumonia in patients receiving ADVAIR 500/50 mcg compared with placebo (16% on ADVAIR DISKUS 500/50 mcg, 14% on fluticasone propionate 500 mcg, 11% on salmeterol 50 mcg and 9% on placebo). Physicians should remain vigilant for the possible development of pneumonia in patients with COPD as the clinical features of pneumonia and exacerbations frequently overlap (see CLINICAL TRIAL ADVERSE DRUG REACTIONS, COPD).

For COPD patients, it is important that even mild chest infections be treated immediately since these patients may be more susceptible to damaging lung infections than healthy individuals. Patients should be instructed to contact their physician as soon as possible if they suspect an infection.

Physicians should recommend that COPD patients receive an annual influenza vaccination.

Special Populations

Use In Women

Fertility

There are no data on human fertility (see TOXICOLOGY, Reproduction).

Pregnant Women

There are no adequate and well-controlled clinical trials with ADVAIR/ADVAIR DISKUS in pregnant women and the safety of ADVAIR/ADVAIR DISKUS in pregnancy has not been adequately established. ADVAIR/ADVAIR DISKUS should be used during pregnancy only if the potential benefit justifies the potential risk to the fetus.

There are limited data from an observational epidemiological study with ADVAIR/ADVAIR DISKUS in pregnant women.

Results from a retrospective epidemiological study based on the UK General Practice Research Database (GPRD), did not find an increased risk of major congenital malformations following exposure to fluticasone propionate when compared to other inhaled corticosteroids, during the first trimester of pregnancy (see DETAILED PHARMACOLOGY).

In animal studies, some effects on the fetus, typical for a beta-agonist, occurred at exposure levels substantially higher than those that occur with therapeutic use. Extensive use of other beta-agonists has provided no evidence that effects in animals are relevant to human use.

Like other glucocorticoids, fluticasone propionate is teratogenic to rodent species. Adverse effects typical of potent corticosteroids are only seen at high systemic exposure levels; administration by inhalation ensures minimal systemic exposure. The relevance of these findings to humans has not yet been established since well-controlled trials relating to fetal risk in humans are not available. Infants born of mothers who have received substantial doses of glucocorticoids during pregnancy should be carefully observed for hypoadrenalism.

Use in Labour and Delivery

There are no well-controlled human studies that have investigated effects of salmeterol on preterm labour or labour at term. Because of the potential for beta-agonist interference with uterine contractility, use of ADVAIR/ADVAIR DISKUS during labour should be restricted to those patients in whom the benefits clearly outweigh the risks.

Nursing Women

Plasma levels of salmeterol after inhaled therapeutic doses are very low (85 to 200 pg/mL) in humans and therefore levels in milk should be correspondingly low. Studies in lactating animals indicate that salmeterol is likely to be secreted in only very small amounts in breast milk.

Glucocorticoids are excreted in human milk. The excretion of fluticasone propionate into human breast milk has not been investigated. When measurable plasma levels were obtained in lactating laboratory rats following subcutaneous administration, there was evidence of fluticasone propionate in the breast milk. However, plasma levels in patients following inhaled fluticasone propionate at recommended doses are likely to be low.

Since there is no experience with use of ADVAIR/ADVAIR DISKUS by nursing mothers, a decision should be made whether to discontinue nursing or to discontinue the drug, taking into account the importance of the drug to the mother.

Pediatrics: (≥ 4 years of age): In adolescents and children, the severity of asthma may vary with age and periodic reassessment should be considered to determine if continued maintenance therapy with ADVAIR/ADVAIR DISKUS is still indicated.

Also see Monitoring and Laboratory Tests.

The safety and efficacy of ADVAIR DISKUS in children younger than 4 years of age have not been established.

The safety and efficacy of ADVAIR in children younger than 12 years of age have not been established.

Geriatrics: As with other beta₂-agonists, special caution should be observed when using salmeterol in elderly patients who have concomitant cardiovascular disease that could be adversely affected by this class of drug. Based on available data, no adjustment of salmeterol dosage in geriatric patients is warranted.

Monitoring And Laboratory Tests

Monitoring Control of Asthma or COPD

ADVAIR/ADVAIR DISKUS should not be introduced in acutely deteriorating asthma or COPD, which is a potentially life threatening condition. Increasing use of rapid onset, short duration inhaled bronchodilators to control symptoms indicates deterioration of asthma control. Sudden and progressive deterioration in asthma control is potentially life-threatening and the treatment plan should be re-evaluated. Also, where the current dosage of ADVAIR/ADVAIR DISKUS has failed to give adequate control of asthma (in patients with reversible obstructive airways disease) the patient should be reviewed by a physician. Before introducing ADVAIR/ADVAIR DISKUS, adequate education should be provided to the patient on how to use the drug and what to do if asthma flares up.

During long-term therapy, HPA axis function and haematological status should be assessed periodically. For patients at risk, monitoring of bone and ocular effects (cataract, glaucoma, and central serous chorioretinopathy) should also be considered in patients receiving maintenance therapy with ADVAIR/ADVAIR DISKUS. It is recommended that the height of children receiving prolonged treatment with inhaled corticosteroids is regularly monitored.

ADVERSE REACTIONS

Adverse Drug Reaction Overview

The type and severity of adverse reactions associated with fluticasone propionate and salmeterol xinafoate may be expected with ADVAIR/ADVAIR DISKUS. There are no additional adverse reactions attributed to the combination product when compared to the adverse event profiles of the individual components.

Adverse drug reactions based on the frequency of reported events from pooled clinical trial data (23 asthma and 7 COPD studies) are listed in Table 2 below. Frequencies are defined as: very common ($\geq 1/10$), common ($\geq 1/100$ to $<1/10$), uncommon ($\geq 1/1000$ to $<1/100$), rare ($\geq 1/10,000$ to $<1/1000$) and very rare ($<1/10,000$). The frequency of adverse drug reactions based on spontaneous adverse event reporting data is presented separately (see Post-Market Adverse Drug Reactions).

Table 2 Adverse Drug Reactions based on the frequency of reported events from pooled clinical trial data (23 asthma and 7 COPD studies)

MedDRA preferred term	Frequency
Cardiac disorders	
Atrial fibrillation	uncommon
Tachycardia	uncommon
Palpitations	uncommon
Cardiac arrhythmia	rare
Supraventricular tachycardia	rare
Supraventricular extrasystoles	rare
Ventricular extrasystoles	rare
Eye disorders	
Cataract	uncommon
Glaucoma	rare
Infections and Infestations	
Oral candidiasis	common
Pneumonia	common (COPD patients)
Immune system disorders	
Cutaneous hypersensitivity reactions	uncommon
Dyspnoea	uncommon
Anaphylactic reaction	rare
Metabolism and nutrition disorders	
Hyperglycemia	uncommon
Musculoskeletal and connective tissue disorders	
Arthralgia	common
Muscle spasms	common
Nervous system disorders	
Headache (see Warnings and Precautions)	very common
Tremor (see Warnings and Precautions)	uncommon
Psychiatric disorders	
Anxiety	uncommon
Sleep disorder	uncommon
Psychomotor hyperactivity	rare
Irritability	rare
Abnormal behaviour	rare
Respiratory, thoracic and mediastinal disorders	
Dysphonia/Hoarseness	common
Throat irritation	uncommon
Skin and subcutaneous tissue disorders	
Contusion	uncommon

In addition to the pooled data above, symptoms of laryngeal spasm, irritation, or swelling, such as stridor and choking, have been reported rarely in patients receiving salmeterol. Clinically significant hypokalemia has also been seen rarely during long-term administration of salmeterol at recommended doses.

In rare cases, patients on inhaled fluticasone propionate may present with systemic eosinophilic conditions, with some patients presenting with clinical features of vasculitis consistent with EGPA, a condition that is often treated with systemic corticosteroid therapy (see WARNINGS AND PRECAUTIONS, Hematologic, Eosinophilic Conditions).

Clinical Trial Adverse Drug Reactions

By Indication

Because clinical trials are conducted under very specific conditions the adverse reaction rates observed in the clinical trials may not reflect the rates observed in practice and should not be compared to the rates in the clinical trials of another drug. Adverse drug reaction information from clinical trials is useful for identifying drug-related adverse events and for approximating rates.

Asthma

Use of LABA monotherapy increases the risk of serious asthma-related events (death, hospitalizations, and intubations) (see WARNINGS AND PRECAUTIONS, General).

ADVAIR DISKUS Inhalation Powder

In clinical trials involving 1824 adult and adolescent patients with asthma, the most commonly reported adverse events with the combination fluticasone propionate/salmeterol xinafoate DISKUS were: hoarseness/dysphonia, throat irritation, headache, candidiasis of mouth and throat and palpitations as detailed in the table below:

Table 3 Number (and percentage) of patients with drug-related adverse events (incidence $\geq 1\%$) (Safety Population)

Adverse events	Fluticasone propionate/ salmeterol xinafoate combination product	Fluticasone propionate and salmeterol xinafoate concurrent therapy	Fluticasone propionate alone	Salmeterol xinafoate alone	Placebo
Number of patients	644	486	339	180	175
Any event	110 (17%)	81 (17%)	50 (15%)	9 (5%)	5 (3%)
Hoarseness/dysphonia	15 (2%)	11 (2%)	8 (2%)	1 (<1%)	0
Throat irritation	14 (2%)	10 (2%)	8 (2%)	1 (<1%)	1 (<1%)
Candidiasis of mouth and throat	15 (2%)	9 (2%)	5 (1%)	0	0
Headaches	16 (2%)	11 (2%)	3 (<1%)	0	0
Asthma ²	9 (1%)	11 (2%)	3 (<1%)	0	0
Palpitations	7 (1%)	4 (<1%)	2 (<1%)	1 (<1%)	0
Cough	6 (<1%)	2 (<1%)	5 (1%)	1 (<1%)	0
Breathing disorders	6 (<1%)	2 (<1%)	4 (1%)	0	0
Candidiasis-unspecified site	6 (<1%)	3 (<1%)	4 (1%)	0	2 (1%)
Upper respiratory tract infection	5 (<1%)	5 (1%)	2 (<1%)	0	0

¹ in any integrated treatment group

² asthma was not recorded as an adverse event in those studies which included treatment with salmeterol xinafoate alone or placebo (unless it was a serious adverse event)

In the ADVAIR DISKUS group, there was no apparent relationship to fluticasone propionate dose for drug-related adverse events (15% with 100/50 mcg, 19% with 250/50 mcg and 17% with 500/50 mcg).

ADVAIR Pressurised Inhalation, Suspension

In clinical trials, the most commonly reported adverse events with the combination fluticasone propionate/salmeterol xinafoate pressurised inhalation, suspension were: hoarseness/dysphonia, throat irritation and headache. All other adverse events with a reasonable possibility of being related to study drug were reported in $\leq 1\%$ of subjects.

Table 4 Number (and percentage) of patients with drug-related adverse events (incidence $\geq 1\%$ ¹) (Safety Population)

Adverse events	Fluticasone propionate/ salmeterol xinafoate MDI combination product	Fluticasone propionate alone	Salmeterol xinafoate alone	Placebo
Number of patients	622	614	274	176
Any event	67 (11 %)	71 (11 %)	29 (11%)	9 (5%)
Hoarseness/dysphonia	13 (2 %)	7 (1 %)	3 (2 %)	0 (0 %)
Throat irritation	13 (2 %)	14 (2 %)	10 (4 %)	3 (2 %)
Candidiasis of mouth and throat	8 (1 %)	8 (1 %)	0 (0 %)	1 (<1 %)
Headaches	11 (2 %)	11 (2 %)	5 (2 %)	3 (2 %)
Cough	3 (<1 %)	3 (<1 %)	6 (2%)	1 (<1 %)
Hyposalivation	6 (1 %)	2 (<1 %)	1 (<1 %)	0 (0 %)

¹ in any integrated treatment group
MDI = metered dose inhaler

The incidence of drug-related adverse events for the MDI combination product groups was similar to the individual components.

Use in children

A total of 257 pediatric patients participated in the clinical development programme and received either the combination 100 mcg fluticasone propionate/50 mcg salmeterol xinafoate DISKUS or concurrent therapy (with fluticasone propionate and salmeterol administered via separate inhalers). Only one drug-related adverse event, candidiasis, was reported with an incidence of 2% or more in the ADVAIR group. The combination product was generally well tolerated and the safety profile was comparable to that observed in the concurrent therapy group.

There have been very rare reports of anxiety, sleep disorders and behavioural changes including hyperactivity and irritability (predominantly in children and adolescents).

COPD

Clinical trial adverse drug reaction data is provided for two 24-week studies, a 52-week study and a 3-year study.

24-week studies

In clinical trials involving 2054 adults with COPD, the most commonly reported adverse events with ADVAIR DISKUS after 24 weeks were: upper respiratory tract infection, throat irritation, headache and musculoskeletal pain as detailed in the table below. These adverse reactions were mostly mild to moderate in severity.

The following table includes all events (whether considered drug-related or non drug-related by the investigator) that occurred at a rate of 3% or greater in either of the groups receiving ADVAIR DISKUS and were more common than in the placebo group.

Table 5 Overall adverse experiences with $\geq 3\%$ incidence in controlled clinical trials with ADVAIR DISKUS in patients with COPD

Adverse Event	ADVAIR DISKUS 500/50 mcg (n = 169) %	ADVAIR DISKUS 250/50 mcg (n = 178) %	Fluticasone propionate 500 mcg (n = 391) %	Fluticasone propionate 250 mcg (n = 399) %	Salmeterol 50 mcg (n = 341) %	Placebo (n = 576) %
Any event	78	70	80	74	68	69
Infections and Infestations						
Upper respiratory tract infection	17	12	18	16	11	15
Sinusitis	3	3	3	6	4	2
Sinusitis/sinus infection	4	2	2	2	1	2
Candidiasis mouth/throat	7	10	12	6	2	<1
Viral respiratory infections	8	6	9	5	5	4
Respiratory, thoracic and mediastinal disorders						
Nasal congestion/blockage	4	3	7	4	4	3
Throat irritation	11	8	9	9	7	6
Upper respiratory inflammation	9	2	7	5	5	5
Hoarseness/dysphonia	3	5	5	5	<1	1
Nervous system disorders						
Dizziness	3	4	2	2	4	2
Headaches	18	16	17	13	14	11
General disorders						
Fever	4	4	3	3	1	3
Malaise & fatigue	4	3	3	3	2	3
Gastrointestinal disorders						
Nausea & vomiting	4	2	4	4	3	3
Musculoskeletal and connective tissue disorders						
Muscle cramps & spasms	8	3	2	2	3	1
Muscle pain	4	0	3	2	1	<1
Musculoskeletal pain	12	9	9	10	12	10

Other COPD Clinical Trial Adverse Drug Reactions (1-3%)

Cardiovascular: arrhythmias, hypertension, palpitations

Drug Interaction, Overdose and Trauma: contusions, fractures, hematomas, lacerations and wounds

Ear/Nose/Throat: ear/nose/throat infections, ear/nose/throat signs and symptoms, ear signs and symptoms, epistaxis, laryngitis, nasal sinus disorders, pharyngitis/throat infections, rhinorrhea/post nasal drip, sputum abnormalities

Endocrine and Metabolism: diabetes mellitus, hypothyroidism

Gastrointestinal: constipation, dental discomfort and pain, diverticulosis, dyspeptic symptoms, gastrointestinal infections, gum signs and symptoms, hyposalivation, oral discomfort and pain; oral lesions, regurgitation and reflux

Hepatic/Biliary/Pancreatic: abnormal liver function tests

Immune: bacterial infections, candidiasis unspecified site, viral infections

Neurologic: anxiety, situational disorders, sleep disorders, syncope, tremors, vertigo

Non-Site Specific: bone and skeletal pain, edema and swelling, non-site specific pain, non-specific condition, soft tissue injuries

Ophthalmologic: dry eyes, eye infections, lacrimal disorders, ocular pressure disorders, visual disturbances

Per-Operative Considerations: postoperative complications

Respiratory: breathing disorders, bronchitis, lower respiratory hemorrhage, lower respiratory signs and symptoms, pneumonia

Skin: fungal skin infections and skin infections

52-week study

After 52 weeks of treatment with ADVAIR DISKUS (500/50 mcg), fluticasone propionate 500 mcg, salmeterol 50 mcg and placebo in 1465 patients with COPD, the most commonly reported drug related adverse event was candidiasis of the mouth and throat (ADVAIR DISKUS 500/50 mcg, 6%; fluticasone propionate 500 mcg, 6%; salmeterol 50 mcg, 1%; placebo, 1%).

3-year study

Study SCO30003 provided safety data on 6,184 patients with moderate to severe COPD who were randomised and received at least one dose of study medication and treated for up to 3 years; defined as the Safety population. The safety profile of ADVAIR DISKUS

over the three-year treatment period was comparable to that seen in previous studies of shorter duration, confirming the long-term tolerability of ADVAIR DISKUS. All three active treatments were well tolerated and the adverse events reported were generally those expected based on clinical experience with these treatments, with the exception of pneumonia. The estimated 3 year probability of having pneumonia reported as an adverse event was 12.3% for placebo, 13.3% for salmeterol, 18.3% for fluticasone propionate and 19.6% for ADVAIR DISKUS (Hazard ratio for ADVAIR DISKUS vs placebo: 1.64, 95% CI: 1.33 to 2.01, $p < 0.001$). There was no increase in pneumonia related deaths for ADVAIR DISKUS; deaths while on treatment that were adjudicated as primarily due to pneumonia were 7 for placebo, 9 for salmeterol, 13 for fluticasone propionate and 8 for ADVAIR DISKUS.

There was no significant difference in probability of bone fracture (5.1% placebo, 5.1% salmeterol, 5.4% fluticasone propionate and 6.3% ADVAIR DISKUS; Hazard ratio for ADVAIR DISKUS versus placebo: 1.22, 95% CI: 0.87 to 1.72, $p=0.248$). The incidence of adverse events of eye disorders, bone disorders, and HPA axis disorders was low and there was no difference observed between treatments. There was no evidence of an increase in cardiac events for ADVAIR DISKUS, fluticasone propionate, and salmeterol.

Post-Market Adverse Drug Reactions

In addition to adverse events reported from clinical trials, the following events have been identified during worldwide use of any formulation of ADVAIR or ADVAIR DISKUS, fluticasone propionate, and/or salmeterol regardless of indication. These events have been chosen for inclusion due to either their seriousness, frequency of reporting, or causal connection to ADVAIR or ADVAIR DISKUS, fluticasone propionate, and/or salmeterol or a combination of these factors.

Vascular disorders

Very Rare: Hypertension and arrhythmias (including atrial fibrillation, supraventricular tachycardia, and extrasystoles).

Endocrine disorders

Rare: Cushing's syndrome, Cushingoid, adrenal suppression (including suppression of HPA axis responsiveness to stress), growth retardation (in children and adolescents), bone density decreased, cataract, glaucoma

Infections and Infestations

Rare: Esophageal candidiasis

Immune system disorders

Uncommon: Cutaneous hypersensitivity reactions

Rare: Urticaria, rash, bronchospasm, angioedema (mainly facial and oropharyngeal edema)

Very rare: Anaphylactic shock or anaphylactic reaction.

Musculoskeletal and connective tissue disorders

Very Rare: osteonecrosis (particularly with previous or concurrent use of systemic steroids (e.g., IV or oral))

Respiratory, thoracic and mediastinal disorders

Rare: bronchospasm paradoxical, upper airway symptoms of laryngeal spasm, irritation, or swelling, such as stridor and choking.

Very rare: Oropharyngeal irritation

In extensive worldwide postmarketing experience, serious exacerbations of asthma, including some that have been fatal, have been reported. In most cases, these have occurred in patients with severe asthma and/or in some patients in whom asthma has been acutely deteriorating (see WARNINGS AND PRECAUTIONS - **Respiratory**), but they have occurred in a few patients with less severe asthma as well. It was not possible from these reports to determine whether ADVAIR or ADVAIR DISKUS contributed to these events or simply failed to relieve the deteriorating asthma.

Metabolism and Nutrition Disorders

Very rare: Hyperglycemia.

Psychiatric Disorders

Very rare: Anxiety, sleep disorders and behaviour changes, including hyperactivity and irritability (predominantly in children and adolescents).

DRUG INTERACTIONS

Overview

Use ADVAIR with caution in patients receiving other medications causing hypokalemia and/or increased QTc interval (diuretics, high dose steroids, anti-arrhythmics) since cardiac and vascular effects may be potentiated.

Fluticasone Propionate

Under normal circumstances, low plasma concentrations of fluticasone propionate are achieved after inhaled dosing, due to extensive first pass metabolism and high systemic clearance mediated by cytochrome P450 3A4 (CYP3A4) in the gut and liver. Hence, clinically significant drug interactions involving fluticasone propionate are unlikely.

A drug interaction study of intranasal fluticasone propionate in healthy subjects has shown that ritonavir (a highly potent CYP3A4 inhibitor) can greatly increase fluticasone propionate plasma concentrations, resulting in markedly reduced serum cortisol concentrations. During post-marketing use, there have been reports of clinically significant drug interactions in patients receiving intranasal or inhaled fluticasone propionate and ritonavir, resulting in systemic corticosteroid effects including Cushing's syndrome and adrenal suppression. Therefore, concomitant use of fluticasone propionate and ritonavir should be avoided, unless the potential benefit to the patient outweighs the risk of systemic corticosteroid side-effects.

This study has shown that other inhibitors of CYP3A4 produce negligible (erythromycin) and minor (ketoconazole) increases in systemic exposure to fluticasone propionate without notable reductions in serum cortisol concentrations. However, there have been a few case reports during world-wide post-market use of adrenal cortisol suppression associated with concomitant use of azole anti-fungals and inhaled fluticasone propionate. Therefore, care is advised when co-administering potent CYP3A4 inhibitors (e.g. ketoconazole) as there is potential for increased systemic exposure to fluticasone propionate.

Salmeterol Xinafoate

Co-administration of repeat dose ketoconazole (a CYP3A4 inhibitor) and salmeterol in healthy subjects resulted in a significant increase in plasma salmeterol exposure (1.4-fold increase in C_{max} and 15-fold increase in AUC). This increase in plasma salmeterol exposure may cause a prolongation of the QT_c interval (See WARNINGS AND PRECAUTIONS and ACTION AND CLINICAL PHARMACOLOGY: Pharmacokinetics).

Drug-Drug Interactions

Table 6 **Established or Potential Drug-Drug Interactions**

Drug Type	Ref	Effect	Clinical comment
Sympathomimetic agents	CT	May lead to deleterious cardiovascular effects.	Aerosol bronchodilators of the rapid onset, short duration adrenergic stimulant type may be used for relief of breakthrough symptoms while using salmeterol for asthma. Increasing use of such preparations to control symptoms indicates deterioration of disease control and the patient's therapy plan should be reassessed. The regular, concomitant use of salmeterol and other sympathomimetic agents is not recommended.
Mono amine Oxidase Inhibitors or Tricyclic Antidepressants	CS	Action of salmeterol on vascular system may be potentiated.	Salmeterol should be administered with extreme caution to patients being treated with monoamine oxidase inhibitors or tricyclic antidepressants, or within 2 weeks of discontinuation of such agents.
Methylxanthines	CT	Unknown	The concurrent use of intravenously or orally administered methylxanthines (e.g., aminophylline, theophylline) by patients receiving salmeterol has not been completely evaluated.
Beta-Blockers	CS	May antagonise the bronchodilating action of salmeterol.	Non-selective beta-blocking drugs should never be prescribed in asthma or COPD. Cardioselective beta-blocking drugs should be used with caution in patients with asthma or COPD.
Acetylsalicylic acid	T		Use with caution in conjunction with corticosteroids in hypoprothrombinemia.
Ritonavir	CT & post-marketing	Systemic effects including Cushing's syndrome and adrenal suppression.	Concomitant use of fluticasone propionate and ritonavir should be avoided. (See DRUG INTERACTIONS, Overview)
Other inhibitors of cytochrome P450 3A4	CT	Increased systemic exposure to fluticasone propionate and salmeterol xinafoate.	Caution is advised when co-administering potent CYP3A4 inhibitors (e.g. ketoconazole, cobicistat-containing products). (See DRUG INTERACTIONS, Overview, WARNINGS AND PRECAUTIONS and ACTION AND CLINICAL PHARMACOLOGY, Pharmacokinetics)

Legend: C = Case Study; CT = Clinical Trial; T = Theoretical; CS = Class Statements

DOSAGE AND ADMINISTRATION

Dosing Considerations

COPD and Asthma

ADVAIR/ADVAIR DISKUS should not be used to treat acute symptoms of asthma or COPD. It is crucial to inform patients of this. Patients should be prescribed a rapid onset, short duration inhaled bronchodilator (e.g., salbutamol) to relieve the acute symptoms such as shortness of breath and advised to have this available for use at all times.

As twice-daily regular treatment, ADVAIR/ADVAIR DISKUS provides twenty-four hour bronchodilation and can replace regular use of a rapid onset, short duration (4 hour) inhaled or oral bronchodilator (e.g. salbutamol). Rapid onset, short duration beta₂-agonists should be used only to relieve acute symptoms of asthma and COPD (See WARNINGS AND PRECAUTIONS).

Patients should be regularly reassessed so that the strength of ADVAIR/ADVAIR DISKUS they are receiving remains optimal and is only changed on medical advice. The dose should be titrated to the lowest dose of fluticasone propionate at which effective control of symptoms is maintained.

There is no need to adjust the dose in the otherwise healthy elderly or in patients with impaired renal function. Because salmeterol is predominantly cleared by hepatic metabolism, patients with hepatic disease should be closely monitored.

Asthma

When treating patients with asthma, physicians should only prescribe ADVAIR/ADVAIR DISKUS for patients not adequately controlled on a long-term asthma control medication, such as an inhaled corticosteroid or whose disease severity clearly warrants treatment with both an inhaled corticosteroid and LABA.

Recommended Dose And Dosage Adjustment

ADVAIR DISKUS Inhalation Powder

	Asthma		COPD	
	Children 4-11 years of age	Adults and adolescents ≥12 years of age	Adults ≥18 years of age	
ADVAIR DISKUS 100	One inhalation twice daily	One inhalation twice daily	--	OR
ADVAIR DISKUS 250	--	One inhalation twice daily	One inhalation twice daily	OR
ADVAIR DISKUS 500	--	One inhalation twice daily	One inhalation twice daily	

ADVAIR Pressurised Inhalation, Suspension

	Asthma	
	Adults and adolescents ≥12 years of age	
ADVAIR 125	Two inhalations twice daily	OR
ADVAIR 250	Two inhalations twice daily	

It is intended that each prescribed dose of ADVAIR Pressurised Inhalation, Suspension be given by a minimum of two inhalations twice daily. However, the prescribed dose of ADVAIR DISKUS Inhalation Powder may be given by a single inhalation twice daily.

Use with Spacer Devices

Spacer devices may be used in patients who have difficulty coordinating the actuation of a metered dose inhaler (MDI) with inhalation. The dosage of ADVAIR pressurised inhalation, suspension should be adjusted according to individual response. For patients whose asthma has been stabilized without the use of a spacer device, continuation of therapy with a spacer may require a dosage adjustment.

Two small single dose pharmacokinetic studies were conducted in subjects with asthma to investigate the performance of various spacer devices. The studies showed that following the administration of ADVAIR pressurised inhalation, suspension, the exposure to both fluticasone propionate (FP) and salmeterol xinafoate (SAL) was significantly higher (up to 4 fold) when used with the AeroChamber Max spacer, compared to the MDI alone. Exposure to FP and SAL was also increased with the use of the AeroChamber Plus and Ventahaler spacers, but to a lesser degree than that seen with the AeroChamber Max spacer. The long term safety and clinical effect of using a spacer device with ADVAIR pressurised inhalation, suspension was not evaluated in these studies.

Missed Dose

If a single dose is missed, instruct the patient to take the next dose when it is due.

Administration

ADVAIR/ADVAIR DISKUS are to be administered by oral inhalation only.

The patient should be made aware that for optimum benefit ADVAIR/ADVAIR DISKUS should be taken regularly, even when asymptomatic.

As a general rule, rinsing the mouth and gargling with water after each inhalation can help in preventing the occurrence of candidiasis. Cleansing dentures has the same effect.

OVERDOSAGE

ADVAIR/ADVAIR DISKUS should not be used more frequently than twice daily (morning and evening) at the recommended dose. Fatalities have been reported in association with excessive use of inhaled sympathomimetic drugs (See WARNINGS AND PRECAUTIONS - **General**). Large doses of inhaled or oral salmeterol (12 to 20 times the recommended dose) have been associated with clinically significant prolongation of the QTc interval, which has the potential for producing ventricular arrhythmias.

There are no data available from clinical trials on overdose with ADVAIR/ADVAIR DISKUS, however data on overdose with individual drugs is given below.

Acute inhalation of fluticasone propionate doses in excess of those approved may lead to temporary suppression of the hypothalamic-pituitary-adrenal axis. This does not usually require emergency action, as normal adrenal function typically recovers within a few days.

The expected signs and symptoms of salmeterol overdose are those typical of excessive beta₂-adrenergic stimulation, including tremor, headache, tachycardia, increases in systolic blood pressure, cardiac arrhythmias, hypokalemia, hypertension and, in extreme cases, sudden death. There is no specific treatment for an overdose of fluticasone propionate and salmeterol. If overdose occurs, the patient should be treated supportively with appropriate monitoring as necessary. The judicious use of a cardioselective beta-receptor blocker may be considered, bearing in mind that such medication can produce bronchospasm.

If higher than approved doses are continued over prolonged periods, significant adrenocortical suppression is possible. There have been very rare reports of acute adrenal crisis occurring in children exposed to higher than approved dosages (typically 1000 mcg daily and above), over prolonged periods (several months or years); observed features included hypoglycemia and sequelae of decreased consciousness and/or convulsions. Situations which would potentially trigger acute adrenal crisis include exposure to

trauma, surgery or infection or any rapid reduction in dosage. Patients receiving higher than approved dosages should be managed closely and the dose reduced gradually.

For management of a suspected drug overdose, contact your regional Poison Control Centre.

ACTION AND CLINICAL PHARMACOLOGY

Mechanism Of Action

ADVAIR/ADVAIR DISKUS contains fluticasone propionate and salmeterol xinafoate which have differing modes of action for the treatment of COPD and asthma (in patients with reversible obstructive airways disease). Fluticasone propionate is an inhaled anti-inflammatory agent that reduces airways irritability; salmeterol is a long-acting bronchodilator that prevents breakthrough symptoms of wheezing and chest tightness. ADVAIR/ADVAIR DISKUS can offer a more convenient regime for patients requiring concurrent long-acting beta₂-agonists and inhaled corticosteroid therapy. ADVAIR/ADVAIR DISKUS is designed to produce a greater improvement in pulmonary function and symptom control than either fluticasone propionate or salmeterol used alone at their recommended dosages. The respective mechanisms of action of both drugs are discussed below:

Salmeterol is a selective, long-acting (12 hours), slow onset (10-20 minutes) beta₂-adrenoceptor agonist with a long side-chain which binds to the exo-site of the receptor. Salmeterol offers more effective protection against histamine-induced bronchoconstriction and produces a longer duration of bronchodilation, lasting for at least 12 hours, than recommended doses of conventional rapid onset, short duration beta₂-agonists.

In vitro tests on human lung have shown that salmeterol is a potent and long-lasting inhibitor of the release of mast cell mediators, such as histamine, leukotrienes and prostaglandin D₂.

In man, salmeterol inhibits the early and late phase response to inhaled allergen. The late phase response is inhibited for over 30 hours after a single dose, when the bronchodilator effect is no longer evident. The full clinical significance of these findings is not yet clear. The mechanism is different from the anti-inflammatory effect of corticosteroids.

Fluticasone propionate is a highly potent glucocorticoid anti-inflammatory steroid. When administered by inhalation at therapeutic dosages, it has a direct potent anti-inflammatory action within the lungs, resulting in reduced symptoms and exacerbations of asthma, and less adverse effects than systemically administered corticosteroids.

In comparisons with beclomethasone dipropionate, fluticasone propionate has demonstrated greater topical potency.

Pharmacodynamics

The pharmacodynamic effects and pharmacokinetics of the combination product in the DISKUS inhalation powder were investigated in healthy adult male and female volunteers after single and repeat-dose administration.

Those studies showed that the systemic pharmacodynamic effects of fluticasone propionate and salmeterol xinafoate are essentially unchanged when the two drugs are administered in combination, when compared with the component drugs given alone or concurrently.

There was no evidence that the systemic exposure to salmeterol was altered by concomitant exposure to fluticasone propionate. In one study, the salmeterol plasma C_{max} and T_{max} were not significantly different when compared between the groups receiving fluticasone propionate 500 mcg and salmeterol xinafoate 100 mcg twice daily in the combination product (C_{max} 0.23 ng/mL) or salmeterol xinafoate 100 mcg twice daily as a single agent (C_{max} 0.22 ng/mL).

When fluticasone propionate alone or the fluticasone propionate/salmeterol xinafoate product are administered at the same dosage, there is similar systemic exposure to fluticasone propionate.

Pharmacokinetics

There is no evidence in animal or human subjects that the administration of fluticasone propionate and salmeterol xinafoate together by the inhaled route affects the pharmacokinetics of either component. For pharmacokinetic purposes therefore each component can be considered separately.

Salmeterol Xinafoate

Salmeterol acts locally in the lung; therefore, plasma levels are not an indication of therapeutic effect. Because of the low therapeutic dose, systemic levels of salmeterol are low or undetectable after inhalation of recommended doses (50 mcg twice daily). Salmeterol is predominantly cleared by hepatic metabolism; liver function impairment may lead to accumulation of salmeterol in plasma. Therefore, patients with hepatic disease should be closely monitored.

An *in vitro* study showed that salmeterol is extensively metabolised to α -hydroxysalmeterol (aliphatic oxidation) by cytochrome P450 3A4 (CYP3A4). A repeat dose study with salmeterol and erythromycin in healthy volunteers showed no clinically significant changes in pharmacodynamic effects at 500 mg three times daily doses of erythromycin. However, a salmeterol-ketoconazole interaction study resulted in a significant increase in plasma salmeterol exposure (See WARNING AND PRECAUTIONS, and DRUG INTERACTIONS).

In a placebo-controlled, crossover drug interaction study in 15 healthy subjects, co-administration of salmeterol (50 mcg twice daily inhaled) and the CYP3A4 inhibitor, ketoconazole (400 mg once daily orally), for 7 days, resulted in a significant increase in plasma salmeterol exposure (1.4-fold C_{max} and 15-fold AUC). There was no increase in

salmeterol accumulation with repeat dosing. Three subjects were withdrawn from salmeterol and ketoconazole co-administration due to QTc prolongation or palpitations with sinus tachycardia. In the remaining 12 subjects, co-administration of salmeterol and ketoconazole did not result in a clinically significant effect on heart rate, blood potassium or QTc duration (See WARNINGS AND PRECAUTIONS, and DRUG INTERACTIONS).

Fluticasone Propionate

Following intravenous administration, the pharmacokinetics of fluticasone propionate are proportional to the dose. Fluticasone propionate is extensively distributed within the body. The volume of distribution at steady state is approximately 300 litres and has a very high clearance which is estimated to be 1.1 litre/minute indicating extensive hepatic extraction.

Peak plasma fluticasone propionate concentrations are reduced by approximately 98% within 3-4 hours and only low plasma concentrations are associated with the terminal half-life, which is approximately 8 hours.

Following oral administration of fluticasone propionate, 87-100% of the dose is excreted in the faeces. Following doses of either 1 or 16 mg, up to 20% and 75% respectively, is excreted in the faeces as the parent compound. There is a non-active major metabolite. Absolute oral bioavailability is negligible (< 1%) due to a combination of incomplete absorption from the gastrointestinal tract and extensive first-pass metabolism.

The absolute bioavailability of fluticasone propionate has been estimated from within study comparisons of inhaled and intravenous pharmacokinetic data. In healthy adult subjects the absolute systemic bioavailability of fluticasone propionate from fluticasone propionate-salmeterol pressurised inhalation, suspension and from fluticasone propionate-salmeterol inhalation powder was 5.3% and 5.5% respectively. Systemic absorption of fluticasone propionate occurs mainly through the lungs, and is initially rapid, then prolonged.

The percentage of fluticasone propionate bound to human plasma proteins averages 99%. Fluticasone propionate is extensively metabolised by CYP3A4 enzyme to an inactive carboxylic acid derivative.

STORAGE AND STABILITY

ADVAIR DISKUS inhalation powder

Do not store ADVAIR DISKUS above 25°C. Keep in a dry place, away from direct heat or sunlight.

ADVAIR DISKUS should be safely discarded when the dose counter reads “0” or 1 month after it was removed from the foil pouch, whichever comes first.

ADVAIR pressurised inhalation, suspension

Replace the mouthpiece cover firmly and snap it into position. Store ADVAIR pressurised inhalation, suspension between 15°C and 25°C. Protect from frost and direct sunlight.

SPECIAL HANDLING INSTRUCTIONS

ADVAIR DISKUS inhalation powder

ADVAIR DISKUS should be stored inside the unopened moisture-protective foil pouch and only removed from the pouch immediately before initial use. Discard ADVAIR DISKUS 1 month after opening the foil pouch or when the counter reads “0” (after all blisters have been used), whichever comes first. The inhaler is not reusable. Do not attempt to take the inhaler apart.

ADVAIR pressurised inhalation, suspension

Contents under pressure. Container may explode if heated. Do not place in hot water or near radiators, stoves, or other sources of heat. Even when apparently empty, do not puncture or incinerate container or store at temperatures over 25°C.

As with most inhaled medications in pressurized canisters, the therapeutic effect of this medication may decrease when the canister is cold.

DOSAGE FORMS, COMPOSITION AND PACKAGING

ADVAIR DISKUS inhalation powder

ADVAIR DISKUS is an inhalation powder plastic inhaler device containing a foil strip with 28 or 60 regularly placed blisters each containing 100, 250 or 500 mcg of fluticasone propionate and 50 mcg of salmeterol (as the xinafoate salt) per inhalation. Each blister also contains lactose (milk sugar), including milk protein, which acts as the “carrier”.

The inhaler is packaged in a plastic-coated, moisture-protective foil pouch.

ADVAIR pressurised inhalation, suspension

ADVAIR is a pressurized metered-dose inhaler (MDI) consisting of an aluminum canister fitted with a metering valve. Each canister is fitted into the supplied purple actuator/adaptor. A dust cap is fitted over the actuator’s mouthpiece when not in use.

ADVAIR comprises a suspension of fluticasone propionate and salmeterol in the propellant HFA-134a (1,1,1,2-tetrafluoroethane). It contains no excipients. ADVAIR delivers 125 or 250 mcg of fluticasone propionate and 25 mcg of salmeterol per actuation.

Available in 120 dose formats.

PART II: SCIENTIFIC INFORMATION

PHARMACEUTICAL INFORMATION

Drug Substance

Proper name: salmeterol xinafoate

Chemical name: 4-hydroxy- α^1 -[[[6-(4-phenylbutoxy) hexyl]amino]-methyl]-1,3-benzenedimethanol, 1-hydroxy-2-naphthoate.

Molecular formula and molecular mass: $C_{25}H_{37}NO_4 \cdot C_{11}H_8O_3$ 603.8

Structural formula:

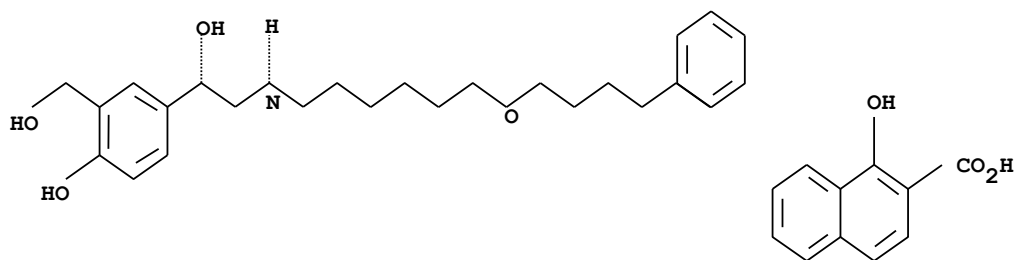

Physicochemical properties:

Description: White to off-white crystalline powder with a melting point ~ 123 °C

Solubility:

In water ~ 0.07 mg/mL (pH = 8)
In saline ~ 0.08 mg/mL (0.9%w/v)
In methanol ~ 40 mg/mL
In ethanol ~ 7 mg/mL
In chloroform ~ 3 mg/mL
In isopropanol ~ 2 mg/mL

pKa and pH:

Salmeterol is amphoteric and is partially ionised in water over the whole pH range. The ionised species have a low solubility, thus accurate determination of the two macro-dissociation constants by potentiometric titration has not been possible. The apparent pKa for dissociation of the phenolic group (as determined by ultraviolet spectrophotometry) is 9.3. The four microconstants lie between 8.9 and 9.7.

The pH of a saturated aqueous solution of salmeterol xinafoate (0.07 mg/mL) is about 8.

Partition Coefficient:

The partition coefficient between n-octanol and water is pH dependent and has been determined by an HPLC procedure.

log D = 3.2 (pH 9.2)

log D = 2.0 (pH 7.4)

log D = 0.6 (pH 4.0)

Drug Substance

Proper name: fluticasone propionate

Chemical name: s-fluoromethyl 6 α ,9 α -difluoro-11 β -hydroxy-16 α -methyl-3-oxo-17 α -propionyloxyandrost-1,4-diene-17 β -carbothioate

Molecular formula and molecular mass: C₂₅H₃₁F₃O₅S 500.6

Structural formula:

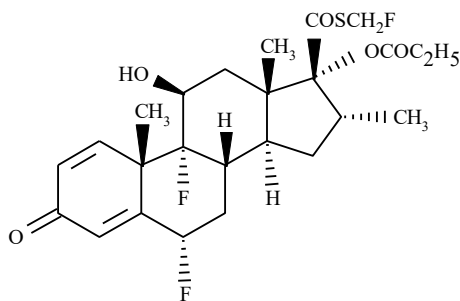

Physicochemical properties:

Description: Fluticasone propionate is a white to off-white powder. It is freely soluble in dimethyl sulfoxide and dimethylformamide, sparingly soluble in acetone, dichloromethane, ethyl acetate and chloroform, slightly soluble in methanol and 95% ethanol, and practically insoluble in water. Fluticasone propionate decomposes without melting. Onset of decomposition occurs at about 225°C.

CLINICAL TRIALS

Clinical Studies in Asthma

There have been very rare reports of anxiety, sleep disorders and behavioural changes including hyperactivity and irritability (predominantly in children and adolescents).

ADVAIR DISKUS Fluticasone Propionate and Salmeterol Inhalation Powder

Use in adolescents and adults

Clinical studies in patients 12 years of age and older showed that the combination product was significantly more effective than placebo or salmeterol alone in all primary efficacy comparisons. It was significantly more effective than fluticasone propionate alone in all primary efficacy comparisons ($p < 0.001$) except in one study for probability of remaining in the study ($p = 0.084$).

In clinical studies comparing the efficacy and safety of the combination product versus concurrent therapy with fluticasone propionate and salmeterol administered via separate inhalers, results for the primary efficacy variable, mean morning PEFr during weeks 1-12, in the Intent-to-Treat Population met the criterion for clinical equivalence (90% confidence limits for the difference between treatments contained within +15L/min) in two studies. Results were similar when the 95% confidence limits were considered rather than 90%. In the study using the 100/50 mcg dose, equivalence was not demonstrated, with treatment differences indicating a slightly greater efficacy for the combination product.

In randomized, double-blind, placebo-controlled trials involving 700 patients aged 12 years and over, treatment with 100/50 mcg or 250/50 mcg fluticasone propionate/salmeterol xinafoate DISKUS produced clinically significant improvements in quality of life as assessed by the Asthma Quality of Life Questionnaire (AQLQ). There were significant differences in quality of life between the combination product and salmeterol xinafoate 50 mcg alone, fluticasone propionate 100 mcg or 250 mcg alone, or placebo. Differences between the combination product and salmeterol or placebo were clinically significant. In these 2 studies, survival analysis revealed that patients treated with 100/50 mcg or 250/50 mcg fluticasone propionate/salmeterol xinafoate DISKUS also had a significantly greater probability of remaining in the study over time without being withdrawn because of worsening asthma than did those in the salmeterol or fluticasone treatment groups. ($p \leq 0.020$ and $p \leq 0.002$ respectively). In both studies, statistically significantly fewer patients receiving the fluticasone/salmeterol combination were withdrawn from the study due to worsening asthma (3% and 4%) compared with fluticasone (11% and 22%), salmeterol (35% and 38%) and placebo (49% and 62%). The combination product significantly reduced symptom scores and supplemental salbutamol use compared with the other treatments. In the first study, regardless of baseline asthma therapy (inhaled corticosteroids or salmeterol), greater improvements in asthma control were observed with the combination as compared to the individual agents. In both studies, the mean change from baseline in pre-dose FEV₁ at the Week 12 endpoint was significantly greater in the combination group ($p < 0.001$ and $p = 0.003$ respectively).

compared to fluticasone propionate alone with no apparent diminution in the 12-hour bronchodilator effect following 12 weeks of therapy.

At the Week 12 endpoint, patients treated with the combination had a 25% and 23% improvement from baseline in FEV₁ respectively.

In a randomized, double-blind, active-controlled trial involving 267 patients aged 12 years and over, who were uncontrolled on short-acting beta₂-agonist therapy, treatment with 100/50 mcg fluticasone propionate/salmeterol xinafoate DISKUS demonstrated superior efficacy and comparable safety compared with salmeterol (50 mcg) or fluticasone propionate (100 mcg) alone. ADVAIR DISKUS 100/50 mcg was proven to be significantly more efficacious than salmeterol alone for the mean change from baseline in morning pre-dose FEV₁ at endpoint ($p = 0.036$). In addition, ADVAIR DISKUS achieved significantly better results than fluticasone propionate alone for area under the serial FEV₁ curve at treatment week 12 relative to baseline ($p = 0.021$). Lung function parameters, asthma symptoms, and VENTOLIN use all showed statistically significant and clinically relevant improvements with the combination product compared with its individual components.

Two, randomized, double-dummy, parallel-group, 12-week comparative trials of ADVAIR DISKUS 100/50 mcg versus oral montelukast 10 mg once-daily were conducted. 855 patients 15 years and older with persistent asthma inadequately controlled with scheduled or as needed short-acting beta₂-agonists alone were enrolled. In both trials, ADVAIR DISKUS was significantly more efficacious ($p < 0.001$, morning pre-dose FEV₁) and has a similar tolerability and adverse event profile compared to the once-daily montelukast.

Use in children

The efficacy of ADVAIR DISKUS 100/50 mcg was compared to concurrent therapy with fluticasone propionate and salmeterol xinafoate administered via separate inhalers in children 4-11 years old. The adjusted mean change in morning PEF_R from baseline for Weeks 1-12 were 33L/min for the combination product and 28L/min for concurrent therapy. Patients responded similarly in both treatment groups with marked reduction of asthma symptoms and VENTOLIN use during the study.

ADVAIR Fluticasone Propionate and Salmeterol Pressurised Inhalation, Suspension

Use in adolescents and adults

In clinical trials comparing ADVAIR pressurised inhalation, suspension with individual components, improvements in most efficacy endpoints were greater with ADVAIR pressurised inhalation, suspension than with the use of either fluticasone propionate or salmeterol alone. In addition, clinical trials showed comparable results between ADVAIR pressurised inhalation, suspension and ADVAIR DISKUS.

When compared to salmeterol alone, ADVAIR pressurised inhalation, suspension was significantly more efficacious in terms of asthma stability (probability of remaining in the

study and change from baseline at endpoint in morning predose FEV₁). ADVAIR pressurised inhalation, suspension was comparable or superior to salmeterol in area under the 12-hour serial FEV₁ curve relative to baseline [AUC(bl)] at Treatment Week 1 and Treatment Week 12, respectively.

When compared to fluticasone propionate alone, patients receiving ADVAIR pressurised inhalation, suspension had significantly greater increases from baseline at endpoint in morning predose FEV₁ and serial FEV₁ results relative to baseline [AUC(bl)] at Treatment Week 1 and Treatment Week 12, respectively.

Patients' perceptions of the impact of asthma on their quality of life were assessed with the Asthma Quality of Life Questionnaire (AQLQ). Patients receiving ADVAIR pressurised inhalation, suspension 125/25 mcg had improvements in overall asthma-related quality of life (mean of 4 AQLQ domain scores: activity limitation, asthma symptoms, emotional function, and environmental stimuli) compared with placebo, fluticasone propionate 125 mcg and salmeterol 25 mcg. Clinically meaningful (≥ 0.5 point differences between groups in mean overall AQLQ score change from baseline) improvements were seen in patients receiving ADVAIR pressurised inhalation, suspension 125/25 mcg compared with placebo, and salmeterol 25 mcg.

In a one-year study, evaluating the safety of ADVAIR pressurised inhalation, suspension 125/25 mcg and 250/25 mcg, improvements in FEV₁ (0.17 to 0.23L at 4 weeks) were seen across both treatment groups and were sustained throughout the 52-week treatment period. Few patients (4%) were withdrawn due to worsening asthma over 1 year.

The onset of action and progression of improvement in asthma control were evaluated in 3 studies. Following the first dose, the median time to onset of clinically significant bronchodilation ($\geq 15\%$ improvement in FEV₁) in most patients was seen within 30 to 60 minutes. Maximum improvement in FEV₁ occurred within 4 hours, and clinically significant improvement was maintained for 12 hours. Additionally, significant improvement in morning PEF, asthma symptom scores, and VENTOLIN use were observed within 1 day and in evening PEF within 12 hours after initiating treatment with the ADVAIR pressurised inhalation, suspension. Improvement continued over the weeks of therapy in all 3 studies.

Following the initial dose, predose FEV₁ relative to day 1 baseline improved markedly over the first week of treatment and continued to improve over the 12 weeks of treatment in all 3 studies.

Safety Studies in Asthma

Fluticasone Propionate

A 2-year study of patients with asthma receiving CFC-propelled fluticasone propionate pressurised inhalation, suspension (100 and 500 mcg twice daily) demonstrated no statistically significant changes in bone mineral density at any time point (24, 52, 76, and 104 weeks of double blind treatment) as assessed by dual-energy x-ray absorptiometry at lumbar region L1 and L4.

Salmeterol Xinafoate – Serious asthma-related events

Salmeterol Multicenter Asthma Research Trial (SMART)

The Salmeterol Multicenter Asthma Research Trial (SMART) was a 28-week US post-marketing study that evaluated the safety of salmeterol (50 mcg twice daily) compared to placebo each added to usual asthma therapy in adult and adolescent subjects. The study showed a significant increase in asthma-related deaths in patients receiving salmeterol (13 deaths out of 13,176 patients treated with salmeterol versus 3 deaths out of 13,179 patients on placebo; relative risk of 4.37 [95% CI: 1.25, 15.34]). The study was not designed to assess the impact of concurrent inhaled corticosteroid use.

Safety of ADVAIR DISKUS Compared With Inhaled Fluticasone Propionate Alone

Subsequent to the Salmeterol Multicenter Asthma Research Trial, two 26-week, randomized, double-blind, parallel-group, active-controlled, multicenter clinical safety trials, one in 11,679 adult and adolescent subjects aged 12 years and older (NCT01475721) and one in 6,208 pediatric subjects aged 4 to 11 years (NCT01462344) were conducted to evaluate the safety of ADVAIR DISKUS compared with inhaled fluticasone propionate alone.

The primary objective of both trials was to evaluate whether the addition of LABA to inhaled corticosteroid therapy (ADVAIR DISKUS) was non-inferior to inhaled corticosteroid therapy alone (fluticasone propionate) in terms of the risk of a serious asthma-related event (hospitalization, endotracheal intubation, and death). The adult and adolescent trial was designed to rule out a pre-specified risk margin for serious asthma-related events of 2.0 and the pediatric trial was designed to rule out a risk margin of 2.7. A blinded adjudication committee determined whether events were asthma related.

Adult and adolescent subjects enrolled in NCT01475721 had moderate to severe persistent asthma with a history of asthma-related hospitalization or at least 1 asthma exacerbation in the previous year treated with systemic corticosteroid. Subjects were randomized in a 1:1 ratio, within stratification groups based on previous asthma medication and asthma control, to receive ADVAIR DISKUS (100/50 mcg, 250/50 mcg or 500/50 mcg) twice daily or fluticasone propionate inhalation powder (100 mcg, 250 mcg or 500 mcg) twice daily. Pediatric subjects enrolled in NCT01462344 had a diagnosis of asthma and a history of at least 1 asthma exacerbation within the prior 12 months treated with systemic corticosteroid. Subjects were randomized in a 1:1 ratio, within stratification groups based on previous asthma medication, asthma control and number of asthma exacerbations in the prior year, to receive ADVAIR DISKUS (100/50 mcg or 250/50 mcg) twice daily or fluticasone propionate inhalation powder (100 mcg or 250 mcg) twice daily. Patients with life-threatening or unstable asthma were excluded from the 2 clinical trials.

For both trials, ADVAIR DISKUS was non-inferior to fluticasone propionate for time to first serious asthma-related events based on the pre-specified risk margins (Table 7). In

the pediatric trial, there was a higher number of asthma-related hospitalizations in the ADVAIR DISKUS group (27) compared to the fluticasone propionate group (21).

Table 7 Serious Asthma-Related Events in the two 26-Week Safety Trials

	NCT01475721		NCT01462344	
	Adults and adolescents (12 years and older)		Children (4-11 years)	
	ADVAIR DISKUS (n = 5,834)	Fluticasone Propionate (n = 5,845)	ADVAIR DISKUS (n = 3,107)	Fluticasone Propionate (n = 3,101)
Serious asthma-related event (hospitalization, endotracheal intubation, or death) ^a	34 (0.6%)	33 (0.6%)	27 (0.9%)	21 (0.7%)
ADVAIR DISKUS /Fluticasone Propionate Hazard ratio (95% CI)	1.03 (0.64-1.66) ^b		1.29 (0.73-2.27) ^b	
Asthma-related death	0	0	0	0
Asthma-related intubation (endotracheal)	0	2	0	0
Asthma-related hospitalization (≥24-hour stay)	34	33	27	21

^a Number of subjects with an event that occurred within 6 months after the first use of study drug or 7 days after the last date of study drug, whichever date was later. Subjects may have had one or more events, but only the first event was counted for analysis.

^b The hazard ratio for time to first event was based on a Cox proportional hazards regression model with randomized treatment as a covariate and baseline hazards stratified by prior asthma medication and asthma control status. If the resulting upper 95% CI estimate for the relative risk was less than 2.0 (NCT01475721) or less than 2.7 (NCT01462344), then non-inferiority was concluded.

Additional Clinical Study in Asthma

Use in adolescents and adults

The objective of study SAM40027, also known as the GOAL study (The Gaining Optimal Asthma Control study), was to determine whether patients could achieve asthma control based upon definitions derived from internationally accepted guidelines (Global Initiative for Asthma/National Institute of Health - GINA/NIH), by comparing the efficacy of an escalated dose of fluticasone propionate alone or in combination with the long acting beta₂-agonist salmeterol.

Study Demographics and Trial Design

Table 8 Summary of patient demographics for clinical trials in asthma

Study #	Trial design (Duration)	Dosage (mcg), route of administration	Study subjects (n=number)	Mean age (Range)	Gender
SAM40027 GOAL (Bateman et. al., 2004)	Stratified, randomized, double blind, parallel group, step-up, multicentre study Phase 1: 12-36 weeks Phase 2: 16-40 weeks Phase 1 & 2: 52-weeks	ADVAIR DISKUS 100/50, 250/50, 500/50 BID FP ¹ DISKUS 100, 250, 500 BID Oral inhalation	3416	40 (9-83)	1428M/1988F

¹ fluticasone propionate

In SAM40027, the two treatment groups were well matched for all demographic characteristics. The study was divided into two phases, Phase 1: treatment step-up in which treatment was stepped-up every 12 weeks until “Total Control” was achieved or the highest dose of study drug was reached and Phase 2: treatment at constant dose. A broad range of subjects were included in the study and were stratified into 3 groups according to baseline asthma therapy over the 6 months prior to randomization; Stratum 1: ICS naïve or no ICS in last 6 months; Stratum 2: using low doses of inhaled corticosteroid (ICS) in the previous 6 months (≤ 500 mcg BDP daily or equivalent, i.e. ≤ 250 mcg of FP); Stratum 3: using moderate doses of ICS in the previous 6 months (> 500 mcg- 1000 mcg BDP daily or equivalent, i.e. > 250 - 500 mcg of FP).

SAM40027 assessed two pre-defined levels of asthma control: “Well-Controlled” (primary efficacy endpoint) and “Total Control”.

“Well-controlled” was defined as two or more of the following 3 criteria:

- Symptom score* of >1 allowed on ≤ 2 days per week only
- ≤ 2 days and ≤ 4 occasions per week of rescue medication use
- $\geq 80\%$ predicted morning PEF every day

And all of the following criteria:

- no night-time awakenings,
- no exacerbations[#],
- no side effects enforcing a change in therapy.

* Symptom score: 1 was defined as “symptoms for one short period during the day”.

Overall scale: 0(none) –5 (severe).

[#] Exacerbations defined as deterioration in asthma requiring treatment with an oral corticosteroid or an emergency department visit or hospitalization.

“Total Control” was defined as:

- no symptoms, no rescue medication use,
- $\geq 80\%$ predicted morning PEF every day,
- no night-time awakenings,
- no exacerbations[#] and
- no side effects enforcing a change in therapy.

Control needed to be sustained, during weeks 5-12, 17-24, or 29-36 in Phase 1, for at least 6 out of the last 7, or 7 out of the last 8 weeks of treatment to reach the composite endpoints defined above. Direct measurements of airway inflammation and/or hyper-responsiveness were not included in these composite endpoints.

Study Results

In each Stratum, more patients receiving ADVAIR achieved “Well-Controlled” asthma versus inhaled FP alone at the end of Phase I (see Table 9, below).

Table 9 Proportion of patients who achieved “Well-Controlled” asthma in study SAM40027

Primary Endpoint	Associated value and statistical significance for ADVAIR vs. FP	Number of Subjects ²
Proportion of subjects who achieved “Well-Controlled” asthma with ADVAIR compared with FP alone in dose titration phase (Phase I, 12-36 weeks)	Stratum 1: 71% vs. 65% (p=0.039) ¹	1083
	Stratum 2: 69% vs. 52% (p<0.001)	1160
	Stratum 3: 51% vs. 33% (p<0.001)	1135

¹Results for Stratum 1 did not meet the predefined 10% difference between treatments used to indicate a clinically important difference and are presented for completeness only.

²Excludes subjects with missing covariates (baseline FEV₁). Subject whose control status was missing or unevaluable were assessed as ‘not controlled’.

In Stratum 1 (ICS naïve or no ICS in last 6 months) the results for the primary endpoint did not meet the predetermined 10% difference used in the study to indicate a clinically important difference (6% treatment difference was achieved). This observation is consistent with the recommended use of LABA-containing drugs such as ADVAIR, which should not be introduced as initial therapy in these patients. ADVAIR should be used only in patients whose conditions are not adequately controlled using low- to medium-dose inhaled corticosteroids or the severity of whose disease clearly warrants the initiation of treatment with two maintenance therapies.

Table 10 below displays the observed likelihood of achieving “Well-Controlled” asthma and the absolute difference for achieving “Well-Controlled” asthma, when comparing ADVAIR with FP alone.

Table 10 Likelihood of achieving “Well-Controlled” asthma in study SAM40027

Stratum	Likelihood of achieving “Well-Controlled” asthma (ADVAIR compared with FP alone)	Absolute difference for achieving “Well-Controlled” asthma (ADVAIR compared with FP alone)
Stratum 1 ⁺	9% (95%CI: 0%-18%)	6% (95%CI: 0%-11%)
Stratum 2	31% (95%CI: 19%-44%)	16% (95%CI: 10%-22%)
Stratum 3	51% (95%CI: 31%-74%)	17% (95%CI: 11%-23%)

⁺ Stratum 1 results did not meet the predetermined 10% difference used to indicate a clinically important difference for the primary endpoint of achieving “Well-Controlled” asthma

Similar results were observed with “Total Control” of asthma, where more patients receiving ADVAIR achieved “Total Control” of asthma versus inhaled FP alone at the end of Phase I for each individual Stratum⁺ (p<0.001). Table 11 below displays the observed likelihood of achieving “Total Control” of asthma and the absolute difference for achieving “Total Control” of asthma, when comparing ADVAIR with FP alone.

Table 11 Likelihood of achieving “Total Control” of asthma in study SAM40027

Stratum	Likelihood of achieving “Total Control” of asthma (ADVAIR compared with FP alone)	Absolute difference for achieving “Total Control” of asthma (ADVAIR compared with FP alone)
Stratum 1 ⁺	34% (95%CI: 14%-58%)	11% (95%CI: 5%-16%)
Stratum 2	65% (95%CI: 35%-101%)	13% (95%CI: 8%-18%)
Stratum 3	124% (95%CI: 63%-209%)	10% (95%CI: 6%-14%)

⁺ Stratum 1 results did not meet the predetermined 10% difference used to indicate a clinically important difference for the primary endpoint of achieving “Well-Controlled” asthma

In general, these effects were observed earlier with ADVAIR compared to FP alone and at a lower ICS dose. In those patients achieving “Well-controlled” asthma or “Total control” of asthma, across all Strata⁺, the time to achieve the first “Well-Controlled” or “Total Control” week during Weeks 1-12 was faster with ADVAIR compared to FP alone (p≤0.002).

Attaining “Well-Controlled” asthma and “Total Control” of asthma resulted in an improved Quality of Life (QoL) as measured by the Asthma Quality of Life Questionnaire (AQLQ). In Stratum 2 (Week 52), 64% and 53% of patients reported minimal or no impairment on QoL after treatment with ADVAIR and FP alone, respectively, compared to 10% and 8% at baseline. In Stratum 3 (Week 52), 57% and 45% of patients reported minimal or no impairment on QoL after treatment with ADVAIR and FP alone, respectively, compared to 8% and 9% at baseline. Sustained and continuous treatment for 52 weeks also resulted in significantly greater mean FEV₁ at each of the clinic visits in patients receiving ADVAIR compared to those receiving FP

⁺ Stratum 1 results did not meet the predetermined 10% difference used to indicate a clinically important difference for the primary endpoint of achieving “Well-Controlled” asthma

alone ($p < 0.001$). Differences between blinded treatments ranged from 0.13L to 0.16L in Stratum 2, and 0.11L to 0.15L in Stratum 3 in favour of ADVAIR.

In SAM40027, an adverse event was defined as any untoward medical occurrence in a subject and did not necessarily have a causal relationship with any treatment. During the blinded treatment period, the percentage of patients who had an adverse event was similar between treatment groups for each Strata: 56% in the FP group and 55% in the ADVAIR group for Stratum 1, 57% FP and 60% ADVAIR for Stratum 2, and 67% FP and 69% ADVAIR in Stratum 3. Drug-related adverse events that were reported by at least 1% of subjects in either treatment group (all Strata combined) were: hoarseness (2% FP vs. 3% ADVAIR), oral candidiasis (2% FP vs. 2% ADVAIR) and pharyngolaryngeal pain (1% FP vs. <1% ADVAIR). There was a greater number of subjects experiencing myocardial infarction and unstable angina or angina pectoris in ADVAIR ($n=8$) compared with FP alone ($n=3$); however, none of these events were considered by the investigator to be related to the study medication.

Clinical Studies in COPD

Clinical study data is provided for a 52-week study.

52-week study

A long term (52 week) clinical study in 1465 COPD patients evaluated the safety and efficacy of ADVAIR DISKUS 500/50 (fluticasone propionate/salmeterol xinafoate) versus placebo and the individual components fluticasone propionate 500 mcg and salmeterol 50 mcg, all taken twice daily via the DISKUS inhalation device. Patients who had an established clinical history of COPD with a pre-bronchodilator FEV_1 of ≥ 25 to $\leq 70\%$ of predicted normal, poor reversibility of airflow obstruction (defined as an increase of $< 10\%$ of the predicted normal FEV_1 value following the administration of 400 mcg salbutamol), and pre-bronchodilator FEV_1/FVC ratio of $\leq 70\%$ were included in the study. Patients who had respiratory disorders other than COPD, those requiring long term oxygen or those who received inhaled or systemic corticosteroids or antibiotic therapy in the 4 weeks prior to study start were excluded.

The primary measure of efficacy was pre-bronchodilator FEV_1 .

Pre-bronchodilator FEV_1 in the ADVAIR DISKUS 500/50 group was 133mL higher than the placebo group ($p < 0.001$), 73mL higher than the salmeterol 50 mcg group ($p < 0.001$) and 95 mL higher than the fluticasone 500 mcg group ($p < 0.001$) throughout the treatment period.

Disease-specific quality of life was assessed with the St. George's Respiratory Questionnaire (SGRQ). With ADVAIR DISKUS 500/50, the raw mean changes in Total Score ranged from -2.4 at Week 2 to -4.5 at Week 52. A clinically meaningful change of > 4.0 was achieved as early as 8 weeks with ADVAIR DISKUS 500/50 but not with placebo, salmeterol 50 mcg or fluticasone 500 mcg.

The overall incidence of adverse events and COPD-related adverse events was similar across the four groups during the treatment period. Most commonly reported drug-related adverse event was candidiasis of the mouth and throat (ADVAIR DISKUS 500/50 mcg, 6%; fluticasone 500 mcg, 6%; salmeterol 50 mcg, 1%; placebo, 1%). Lower respiratory tract infections and pneumonia occurred in 7% of patients in the placebo and salmeterol groups compared to 12% and 14% in the fluticasone propionate 500 mcg and ADVAIR DISKUS 500/50 mcg groups respectively.

No clinically significant effects were observed following any treatment on ECG findings, vital signs or bruise count.

Bone density and fracture rates were not assessed in this study.

DETAILED PHARMACOLOGY

Note: For complete information on the pharmacology of the individual compounds fluticasone propionate and salmeterol xinafoate, please refer to the SEREVENT and FLOVENT Product Monographs.

Animals

A safety pharmacology study was performed to determine the potential interaction of subcutaneously administered fluticasone propionate with the cardiovascular and respiratory effects of intravenously administered salmeterol xinafoate in anaesthetised guinea-pigs. Fluticasone propionate (10 mg/kg, sc) or vehicle control was administered as two doses at 24 hours and 3 hours prior to dosing with salmeterol xinafoate.

Salmeterol at intravenous doses of 0.01 – 100 mcg/kg (including and exceeding those required for pharmacological effects or amounts likely to be absorbed clinically after inhalation), had no effects other than those consistent with the known pharmacological profile of the compound (decreases in blood pressure and increases in heart rate). These effects were not exacerbated by pre-treatment with fluticasone propionate.

Pharmacokinetics

Plasma concentrations of fluticasone propionate and salmeterol xinafoate administered concomitantly were determined in single dose inhalation studies in the rat and dog. Plasma levels at the lowest dose levels used in the studies (28/73 mcg/kg in the rat, and 48/50 mcg/animal in the dog) were about 30-fold and 26-fold greater in rat and 13-fold and 3- to 5-fold greater in dog than the peak levels likely to occur in man for fluticasone propionate and salmeterol xinafoate.

Repeat dose pharmacokinetics of fluticasone propionate and salmeterol xinafoate has been obtained by monitoring plasma concentrations in inhalation toxicity studies in the rat and dog.

In both species, plasma levels of fluticasone propionate were not affected by salmeterol administered concurrently and plasma levels of salmeterol were not affected by co-administration with fluticasone propionate.

Human

The pharmacodynamic effects and pharmacokinetics of the combination product in the DISKUS inhalation powder were investigated in healthy adult male and female volunteers after single and repeat-dose administration.

Those studies showed that the systemic pharmacodynamic effects of fluticasone propionate and salmeterol xinafoate are essentially unchanged when the two drugs are administered in combination, when compared with the component drugs given alone or concurrently.

There was no evidence that the systemic exposure to salmeterol was altered by concomitant exposure to fluticasone propionate. In one study, the salmeterol plasma C_{max} and T_{max} were not significantly different when compared between the groups receiving fluticasone propionate 500 mcg and salmeterol xinafoate 100 mcg twice daily in the combination product (C_{max} 0.23 ng/mL) or salmeterol xinafoate 100 mcg twice daily as a single agent (C_{max} 0.22 ng/mL).

When fluticasone propionate alone or the fluticasone propionate/salmeterol xinafoate product are administered at the same dosage, there is similar systemic exposure to fluticasone propionate.

Long-Term Outcomes in the Management of COPD

SCO30003 was a 3 year study to assess the effect of treatment with ADVAIR DISKUS 500/50 mcg twice daily, fluticasone propionate 500 mcg twice daily, salmeterol 50 mcg twice daily or placebo on all-cause mortality in 6,112 patients with COPD; defined as the Intent-to-Treat-Efficacy (ITT) population. The patients were 40 to 80 years of age with moderate to severe COPD, with a baseline (pre-bronchodilator) $FEV_1 < 60\%$ of predicted at study entry, and $< 10\%$ of predicted reversibility and were randomised to double-blind medication. During the study, patients were permitted usual COPD therapy with the exception of other inhaled corticosteroids, long-acting bronchodilators and long-term systemic corticosteroids. Survival status at 3 years was determined for all patients regardless of withdrawal from study medication.

The primary endpoint of study SCO30003 was the effect of ADVAIR DISKUS 500/50 mcg twice daily versus placebo on all-cause mortality at 3 years. After three years, 15.2% and 12.6% of patients died in the placebo and ADVAIR DISKUS 500/50 mcg treatment groups respectively, equating to an absolute risk reduction of 2.6%. Based on the results of this study, the hazard ratio for ADVAIR DISKUS 500/50 mcg versus placebo was 0.825 (95% CI 0.68, 1.00, $p = 0.052$), all adjusted for two pre-specified interim analyses. There was a trend towards improved survival in patients treated with ADVAIR DISKUS 500/50 mcg compared with placebo over 3 years however this did not achieve the pre-specified statistical significance level of $p \leq 0.05$.

In study SCO30003, ADVAIR DISKUS 500/50 mcg reduced the rate of moderate to severe exacerbations by 25% compared with placebo (95% CI: 19% to 31%; $p < 0.001$). ADVAIR DISKUS reduced the exacerbation rate by 9% compared with fluticasone propionate (95% CI: 1% to 16%; $p = 0.024$) and 12% compared with salmeterol (95% CI: 5% to 19%; $p = 0.002$).

Health Related Quality of Life, as measured by the St. George's Respiratory Questionnaire (SGRQ) was also improved by all active treatments in comparison with placebo in study SCO30003. An adjusted mean change of -4.3 unit decrease was seen at week 48 with ADVAIR DISKUS 500/50 mcg. The average improvement over three years for ADVAIR DISKUS compared with placebo was -3.1 units (95% CI: -4.1 to -2.1; $p < 0.001$), compared with salmeterol was -2.2 units ($p < 0.001$) and compared with fluticasone propionate was -1.2 units ($p = 0.017$).

Over the 3 year treatment period of study SCO30003, FEV₁ values were also higher in patients treated with ADVAIR DISKUS 500/50 mcg than for those treated with placebo (average difference over 3 years 92 mL, 95% CI: 75 to 108 mL; $p < 0.001$). ADVAIR DISKUS was also more effective than fluticasone propionate or salmeterol in improving FEV₁ (average difference over 3 years 50 mL, $p < 0.001$ for salmeterol and 44 mL, $p < 0.001$ for fluticasone propionate). Averaged over the 3 years of the study, patients treated with ADVAIR DISKUS showed a +29 mL increase from baseline in post-bronchodilator FEV₁ while the placebo, fluticasone propionate or salmeterol groups demonstrated a decline of -62 mL, -15 mL, and -21 mL, respectively.

Fluticasone propionate containing medications in asthma during pregnancy

An observational retrospective epidemiological cohort study utilising electronic health records from the United Kingdom was conducted to evaluate the risk of major congenital malformations following first trimester exposure to inhaled fluticasone propionate alone and fluticasone propionate -salmeterol combination relative to non- fluticasone propionate containing inhaled corticosteroids. No placebo comparator was included in this study given the disease being studied. As an epidemiologic study, biases may not have been controlled to the same extent as in a clinical trial.

Within the asthma cohort of 5362 first trimester inhaled corticosteroid-exposed pregnancies in which major congenital malformations were diagnosed by one year of age, 131 major congenital malformations were identified; in the 1612 (30%) pregnancies which were exposed to fluticasone propionate or fluticasone propionate -salmeterol, 42 diagnosed major congenital malformations were identified. In 3750 (70%) pregnancies which were exposed to non-FP inhaled corticosteroid (ICS), 89 diagnosed major congenital malformations were identified. The adjusted odds ratio for major congenital malformations diagnosed by 1 year was 1.1 (95% CI: 0.5 – 2.3) for fluticasone propionate exposed vs non- fluticasone propionate inhaled corticosteroid exposed women with moderate asthma and 1.2 (95% CI: 0.7 – 2.0) for women with considerable to severe asthma. No difference in the risk of major congenital malformations was identified following first trimester exposure to fluticasone propionate alone versus fluticasone propionate-salmeterol combination. Absolute risks of major congenital malformations

across the asthma severity strata ranged from 2.0 to 2.9 per 100 fluticasone propionate - exposed pregnancies.

TOXICOLOGY

Note: For complete information on the toxicology of the individual compounds fluticasone propionate and salmeterol xinafoate, please refer to the SEREVENT and FLOVENT Product Monographs.

Acute Toxicity

The experimental details of single dose studies are presented below:

Species (strain)	Route of Administration	Nominal Exposure Concentrations (mcg/L) (Salmeterol xinafoate: Fluticasone propionate)	Initial Group		Duration of Treatment (Days)
			M	F	
Rat (Wistar)	Inhalation powder	0:0	10	10	1
		75:40	10	10	
		0:0	5	5	
		10:20	5	5	
		20:40	5	5	
Rat (Wistar)	Inhalation powder	0:0	7	7	1
		1:2	7	7	
		2:4	7	7	
		5:10	7	7	
		10:20	7	7	
20:40	7	7			
Rat (Wistar)	Inhalation powder	0:0	10	0	1
		75:0	10	0	
		75:40	10	0	

High single inhaled doses of combinations of fluticasone propionate and salmeterol xinafoate were well-tolerated by rats. With one exception (mild atrial myocarditis), all findings were expected at the doses of fluticasone propionate and salmeterol xinafoate administered.

Mild atrial myocarditis occurred at combination doses of 28 mcg/kg salmeterol with 73 mcg/kg fluticasone propionate, or higher, at which plasma drug concentrations were at least 30 times (salmeterol) or 26 times (fluticasone propionate) greater than peak levels in man. The change was characterized by degeneration, mononuclear cell infiltration and a predilection for localisation within the left atrium. This change was not observed in earlier studies when the drugs were administered alone.

The lesion was present 48 hours after a single exposure, but had resolved completely and was absent after 14 days. There were no associated rises in plasma enzyme activities (aspartate aminotransferase, lactate dehydrogenase or creatine phosphokinase) 48 hours after exposure. There were no large differences in heart rate or rhythm between rats

given salmeterol alone or in combination with fluticasone propionate, although animals exposed to the combination showed slightly larger and more prolonged falls in blood pressure. No atrial lesions occurred in repeat dose studies in rats.

This is considered unlikely to be of relevance to man because it has been reported in rats after co-administration of other commonly used and clinically well-tolerated beta₂-agonists and corticosteroids.

Long-Term Toxicity

Findings from repeat dose inhalation toxicity studies of up to 13 weeks duration in rats and dogs were generally as expected for the doses of fluticasone propionate and salmeterol xinafoate administered, most being typical of beta₂-agonist or corticosteroid excess.

The experimental details of long-term toxicity studies are provided below:

Species (strain)	Route of Administration	Nominal Exposure Concentrations (mcg/L) (Salmeterol xinafoate: Fluticasone propionate)	Initial Group		Duration of Treatment (Weeks)
			M	F	
Rat (Wistar)	Inhalation	0:0	6	6	2
		2:0.2	7	7	
		20:2	7	7	
Rat (Sprague-Dawley and Wistar)	Inhalation	0:0	5	5	2
		0:2	5	5	
		20:0	5	5	
		20:0.02	5	5	
		20:0.2	5	5	
		20:2	5	5	
Rat (Wistar)	Inhalation	0:0	26	26	2 or 5
		2:4	21	21	
		2:10	21	21	
		4:20	26	26	
		10:20	26	26	
Rat (Wistar)	Inhalation	0:0	41	41	13
		3:0	31	31	
		0:6	31	31	
		0.6:6	31	31	
		3:6	41	41	
Dog (Beagle)	Inhalation	0:0	2	2	2
		15:15	2	2	
		150:150	2	2	
Dog (Beagle)	Inhalation	0:0	2	2	2
		5:0	2	2	
		15:0	2	2	
		5:10	2	2	
		5:25	2	2	
		15:30	2	2	
		15:75	2	2	
Dog (Beagle)	Inhalation	0:0	6	6	13
		15:0	4	4	
		0:30	4	4	
		3:30	4	4	
		15:30	4	4	
		15:30	6	6	

Focal coronary arteritis was the only finding not reported in earlier studies when fluticasone propionate and salmeterol xinafoate were administered alone.

Focal coronary arteritis occurred transiently and sporadically in Wistar rats exposed daily to fluticasone propionate and salmeterol xinafoate combinations for 2 weeks. The lesion was short-lived, resolving fully even with continued treatment, always being absent in studies of 5 and 13 weeks duration. It showed both species and strain specificity, being absent in dogs and Sprague-Dawley rats.

In 2 week inhalation studies in dogs, salmeterol-related pulse rate increases were slightly more marked in groups given the combination compared with those given salmeterol alone. However, there were no significant effects of the combination on ECG or on cardiac histopathology in this species.

Reproduction

Co-administration of high-doses of subcutaneous fluticasone propionate and oral salmeterol did not alter the incidence of any minor or major abnormality in rats or mice compared with studies in which the drugs were administered alone. The incidence of two variants, transposed (left) umbilical artery and incomplete ossification of the occipital bone, were increased in rats at the highest combination dose (100 mcg/kg: 10 mg/kg fluticasone propionate: salmeterol xinafoate).

Exposure at the no-effect dose for both variants of 30 mcg/kg: 1 mg/kg (fluticasone propionate:salmeterol xinafoate) was approximately 12 times (salmeterol) and 4 times (fluticasone propionate) greater than peak exposure in man after a standard 50:50 mcg dose (fluticasone propionate: salmeterol xinafoate).

Mutagenicity

Mutagenicity studies conducted with fluticasone propionate and salmeterol xinafoate alone did not show evidence of genotoxicity.

Genetic toxicity studies with the combination product were not conducted.

Carcinogenicity

In long-term studies, salmeterol xinafoate induced benign tumours of smooth muscle on the mesovarium of rats and the uterus of mice. These findings in rodents are similar to those reported previously for other beta-adrenergic agonist drugs. The relevance of these findings to human is unknown.

No treatment-related effects were observed on the type or incidence of neoplasia in an 18 month oral (gavage) study in mice administered fluticasone propionate at dose levels of up to 1 mg/kg/day. In a lifetime (2 years) snout-only inhalation study in rats, at dose levels of up to 57 mcg/kg/day, there was an increase in the incidence of tumours in the mammary gland, liver and pancreas. These were not considered as evidence of tumorigenic effect of fluticasone propionate based on the absence of statistical support of an increase in incidence and the historical tumour incidence data.

Fluticasone propionate/salmeterol xinafoate combination product was not tested in carcinogenicity studies.

REFERENCES

1. Bateman ED, Britton M, Carrillo J, Almeida J, Wixon C. Salmeterol/fluticasone combination inhaler. A new, effective and well tolerated treatment for asthma. *Clin Drug Invest.* 1998;16(3):193-201.
2. Boulet LP, Cowie R, Johnston P, Krakovsky D, Mark S. Comparison of Diskus inhaler, a new multidose powder inhaler, with Diskhaler inhaler for the delivery of salmeterol to asthmatic patients. Canadian Study Group. *J Asthma.* 1995;32(6):429-436.
3. Calverley MA, Anderson JA, Celli B, Ferguson GT, Jenkins C. Salmeterol and fluticasone propionate and survival in chronic obstructive pulmonary disease. *NEJM.* 2007;356(8):775-789.
4. Chapman KR, Ringdal N, Backer V, Palmqvist M, Saarelainen S, Briggs M. Salmeterol and fluticasone propionate (50/250 microg) administered via combination Diskus inhaler: as effective as when given via separate Diskus inhalers. *Can Respir J.* 1999;6(1):45-51.
5. Dahl R, Lundback B, Malo JL, Mazza JA, Nieminen MM, Saarelainen P et al. A dose-ranging study of fluticasone propionate in adult patients with moderate asthma. International Study Group. *Chest.* 1993;104(5):1352-1358.
6. Falcoz C, Mackie AE, Moss J, Horton J, Ventresca GP, Brown A et al. Pharmacokinetics of fluticasone propionate inhaled from the Diskhaler and the Diskus after repeat doses in healthy subjects and asthmatic patients. *J Allergy and Clin Immunol* 1999;99(0091-6749):s505.
7. Greening AP, Ind PW, Northfield M, Shaw G. Added salmeterol versus higher-dose corticosteroid in asthma patients with symptoms on existing inhaled corticosteroid. Allen & Hanburys Limited UK Study Group. *Lancet.* 1994;344(8917):219-224.
8. Harding SM. The human pharmacology of fluticasone propionate. *Respir Med.* 1990;84 Suppl A:25-29.
9. Kavuru M, Melamed J, Gross G, Laforce C, House K, Prillaman B et al. Salmeterol and fluticasone propionate combined in a new powder inhalation device for the treatment of asthma: a randomized, double-blind, placebo-controlled trial. *J Allergy Clin Immunol.* 2000;105(6 Pt 1):1108-1116.
10. Lundback B, Rawlinson DW, Palmer JB. Twelve month comparison of salmeterol and salbutamol as dry powder formulations in asthmatic patients. European Study Group. *Thorax.* 1993;48(2):148-153.

11. Shapiro G, Lumry W, Wolfe J, Given J, White MV, Woodring A et al. Combined salmeterol 50 microg and fluticasone propionate 250 microg in the diskus device for the treatment of asthma. *Am J Respir Crit Care Med.* 2000;161(2 Pt 1):527-534.
12. Taylor DR, Town GI, Herbison GP, Boothman-Burrell D, Flannery EM, Hancox B et al. Asthma control during long-term treatment with regular inhaled salbutamol and salmeterol. *Thorax.* 1998;53(9):744-752.
13. Van den Berg NJ, Ossip MS, Hederos CA, Anttila H, Ribeiro BL, Davies PI. Salmeterol/fluticasone propionate (50/100 microg) in combination in a Diskus inhaler (Seretide) is effective and safe in children with asthma. *Pediatr Pulmonol.* 2000;30(2):97-105.
14. Woolcock A, Lundback B, Ringdal N, Jacques LA. Comparison of addition of salmeterol to inhaled steroids with doubling of the dose of inhaled steroids. *Am J Respir Crit Care Med.* 1996;153(5):1481-1488.

PART III: CONSUMER INFORMATION**PrADVAIR DISKUS****fluticasone propionate and salmeterol inhalation powder USP**

This leaflet is part III of a three-part "Product Monograph" for ADVAIR DISKUS and is designed specifically for Consumers. This leaflet is a summary and will not tell you everything about ADVAIR DISKUS. Contact your doctor or pharmacist if you have any questions about the drug.

ABOUT THIS MEDICATION**What the medication is used for:****Asthma (patients 4 years old and older):**

Asthma is a chronic inflammatory disease of the lungs characterized by episodes of difficulty in breathing. People with asthma have extra sensitive or "twitchy" airways. During an asthma attack, the airways react by narrowing, making it more difficult for the air to flow in and out of the lungs.

ADVAIR DISKUS should be used in patients:

- who have asthma that is not adequately controlled with a long-term asthma medication such as an inhaled corticosteroid (ICS) alone; or
- whose asthma severity requires treatment with both an ICS and long-acting beta₂ agonist (LABA).

ADVAIR DISKUS should not be the first asthma medication you use unless advised by your doctor. It is only used when a regular ICS medicine along with a fast acting 'reliever' medicine, such as salbutamol are not adequately helping you with your breathing problems. ADVAIR DISKUS helps to prevent breathlessness and wheezing from happening due to asthma.

Control of asthma requires avoiding irritants that cause asthma attacks and taking the appropriate medications. For example, patients should avoid exposure to house dust mites, mold, pets, tobacco smoke and pollens.

Chronic Obstructive Pulmonary Disease (COPD):

COPD is a type of lung disease in which there is often a permanent narrowing of the airways, leading to breathing difficulties. In many patients, this narrowing of the airways is a result of many years of cigarette smoking. If you suffer from COPD, you must stop smoking to prevent further lung damage. Please contact your physician or other health care provider for help in smoking cessation.

ADVAIR DISKUS is to be used for the long-term control of symptoms due to COPD and to prevent wheezing in adults with COPD.

This medicine is for you. Only a doctor can prescribe it for you. Never give it to someone else. It may harm them even if their symptoms are the same as yours.

What it does:

ADVAIR DISKUS contains two medicinal ingredients, fluticasone propionate and salmeterol xinafoate.

Fluticasone propionate is an inhaled corticosteroid.

Corticosteroids are used to treat breathing problems because they have an anti-inflammatory action. They reduce the swelling and irritation in the walls of the small air passages in the lungs and so ease breathing problems.

Salmeterol xinafoate is a LABA. It relaxes the muscles in the walls of the small air passages in the lungs. This helps to open the airways and makes it easier for air to get in and out of the lungs. The effects of salmeterol xinafoate last for at least 12 hours. When it is taken regularly with an inhaled corticosteroid, it helps the small air passages to remain open.

Corticosteroids also help to prevent attacks of asthma. When you take these two ingredients together regularly they will both help to control your breathing difficulties.

When it should not be used:

ADVAIR DISKUS does not act quickly enough to provide relief from a sudden attack of breathlessness or wheezing due to asthma or COPD. A fast acting 'reliever' medicine, such as salbutamol should be used for any sudden attacks of breathlessness or wheezing (e.g., asthma attacks).

Remember:

Do not use ADVAIR DISKUS if you:

- Are allergic or have had an allergic reaction to fluticasone propionate, salmeterol xinafoate.
- Are allergic to lactose (milk sugar) or milk protein.
- Have a medical history of cardiac tachyarrhythmias (problems of your heart beating fast and/or irregularly).
- Have an untreated fungal, bacterial or tuberculosis infection.

What the medicinal ingredients are:

fluticasone propionate and salmeterol xinafoate.

What the nonmedicinal ingredients are:

lactose (milk sugar) and milk protein.

What dosage forms it comes in:

ADVAIR DISKUS is an inhalation powder administered through a plastic inhaler device containing a foil strip with 28 or 60 blisters. Each blister contains 100, 250, or 500 mcg of fluticasone propionate and 50 mcg of salmeterol (as the xinafoate salt) per inhalation.

WARNINGS AND PRECAUTIONS

ADVAIR DISKUS is not for the treatment of acute asthma attacks or sudden increase of breathlessness and wheezing in COPD. If you get a sudden attack of wheezing and breathlessness between your doses of ADVAIR DISKUS, you should use your fast acting ‘reliever’ medicine, such as salbutamol which your doctor has prescribed to you. Use the medication as directed by your doctor.

You may need to also take steroid tablets or syrup during a severe asthma attack, during other illnesses or during times of stress. Your doctor may give you some steroid tablets or syrup to carry with you as well as a steroid warning card, which will give you advice on when and how to use them.

Before and while you use ADVAIR DISKUS talk to your doctor or pharmacist if the following situations apply to you so that they can determine whether you should start or continue taking this medication:

- Have eye problems such as glaucoma, cataracts, blurry vision or other changes in vision.
- Are suffering from any chest infection (cold, bronchitis).
- Have ever had to stop taking another medication for your breathing problems because you were allergic to it or it caused problems.
- Have been told you are allergic to lactose (milk sugar) or milk protein.
- Ever had a yeast infection (thrush) in your mouth.
- Are having treatment for a thyroid condition.
- Have diabetes.
- Have high blood pressure.
- Have heart problems.
- Have had tuberculosis (TB) infections.
- Are taking other “steroids” by mouth or by inhalation.
- Are pregnant, planning to become pregnant or breastfeeding.
- Are taking a medicine called ketoconazole, used to treat fungal infection.
- Are taking medicines used to treat HIV infection (e.g. ritonavir, atazanavir, indinavir, nelfinavir, saquinavir and cobicistat containing products).
- Have liver problems or cirrhosis.

You should avoid coming into contact with anyone who has measles or the chicken pox while taking an ICS. If you or your child are exposed, tell your doctor right away.

Drugs like ADVAIR DISKUS can cause eye disorders:

- **Cataracts:** Clouding of the lens in the eye, blurry vision, eye pain;
- **Glaucoma:** An increased pressure in your eyes, eye pain. Untreated, it may lead to permanent vision loss;

- **Central serous chorioretinopathy (CSCR):** blurry vision or other changes in vision.

Contact your healthcare professional if you experience blurry vision or other vision problems. You should have regular eye exams.

Other warnings you should know about:

Asthma specific warnings:

After you start taking ADVAIR DISKUS, your doctor may change the dosages of your other asthma medicines. Rarely, this may make a patient feel worse rather than better. This especially applies to oral corticosteroids (sometimes referred to as steroids), including prednisone. If your doctor decreases your oral steroid dose, and you become unwell, tell your doctor immediately.

You should have your asthma assessed at regular intervals as agreed upon with your doctor. Once control of your asthma is achieved and maintained, your doctor may further adjust your dose of ADVAIR DISKUS. Do not stop or change the dose of your ADVAIR DISKUS unless your doctor has advised you to do so.

When LABA medicines are used alone without an ICS, they increase the risk of hospitalization and death from asthma problems. ADVAIR DISKUS contains both an ICS and LABA. Studies showed that when an ICS and LABA are used together, there is not a significant increased risk in hospitalizations and death from asthma problems.

Tell your doctor immediately if:

- There is a change in your symptoms such as more coughing, attacks of wheezing, chest tightness, or an unusual increase in the severity of the breathlessness.
- You wake up at night with chest tightness, wheezing or shortness of breath.
- You use increasing amounts of your fast acting ‘reliever’ medicine.

These could be warning signs that your condition may be worsening. Do not stop taking ADVAIR DISKUS without talking to your doctor.

COPD specific warnings:

- **Tell your doctor immediately** if you notice symptoms of a ‘flare up’.
- Patients with COPD have a higher chance of getting pneumonia (a lung infection). Drugs like ADVAIR DISKUS may also increase your chance of getting pneumonia. However, symptoms of pneumonia and COPD ‘flare ups’ frequently overlap. It is therefore important you tell your doctor immediately if you suspect an infection, as even mild chest infections should be treated immediately.

Your doctor may also recommend that you receive a flu shot each year.

You should avoid close contact with people who have colds or the flu (influenza). You should ask your doctor about flu vaccination.

The following warning signs indicate that your COPD condition may be worsening. You should contact your doctor as soon as possible if you notice:

- An unusual increase or decrease in the amount of phlegm.
- An unusual increase in the consistency and stickiness of the phlegm.
- The presence of blood in phlegm.
- A change in the colour of the phlegm to either brown, yellow or green.
- An unusual increase in the severity of the breathlessness, cough or wheeze.
- Symptoms of a cold (e.g., sore throat).
- Unexplained tiredness or fever.
- Chest tightness.
- Unexplained swelling.
- The necessity to increase the number of pillows in order to sleep in comfort.

INTERACTIONS WITH THIS MEDICATION

As with most medicines, interactions with other drugs are possible. Tell your doctor, nurse, or pharmacist about all the medicines you take, including drugs prescribed by other doctors, vitamins, minerals, natural supplements, or alternative medicines.

Drugs that may interact with ADVAIR DISKUS include:

- medicines similar to ADVAIR DISKUS used for your lung disease, as it may increase the risk of experiencing possible side effects. This includes other medicines containing a LABA or a corticosteroid.
- medicines used to treat HIV infection or AIDS (e.g. ritonavir, atazanavir, indinavir, nelfinavir, saquinavir and cobicistat containing products).
- ketoconazole (used to treat fungal infections).
- beta-blockers used in the treatment of high blood pressure or other heart problems (e.g. propranolol) or in the treatment of glaucoma.
- medicines used to treat depression (i.e., tricyclic antidepressants, monoamine oxidase inhibitors).
- medicines used to decrease the level of potassium in your blood (i.e., diuretics). These are also known as “water pills” and are used to treat high blood pressure.
- methylxanthines (such as theophylline) used to treat asthma and COPD.

PROPER USE OF THIS MEDICATION

It is very important that you use your ADVAIR DISKUS every day, twice a day, even if you have no symptoms. This will help you to keep free of symptoms throughout the day and night.

You should not use it more than twice a day. If you take more than one inhaled medicine, make sure you understand the purpose for taking each medication and when you should use them.

Do not stop taking ADVAIR DISKUS suddenly, even if you feel better. Your doctor can provide you with information about how to slowly stop the medication if necessary. Do not change your dose unless told to by your doctor. If you have to go into hospital for an operation, take your ADVAIR DISKUS with you and tell the doctor what medicine(s) you are taking. If your doctor decides to stop the treatment, do not keep any left-over medicine unless your doctor tells you to.

Usual Asthma Dose:

For patients 12 years of age and older, the usual dose is:

- One inhalation ADVAIR DISKUS 100 twice daily
- or One inhalation ADVAIR DISKUS 250 twice daily
- or One inhalation ADVAIR DISKUS 500 twice daily.

For children 4 to 11 years of age the usual dose is:

- One inhalation ADVAIR DISKUS 100 twice daily.

At present, there are insufficient clinical data to recommend the use of ADVAIR DISKUS in children younger than 4 years of age.

Usual COPD Dose:

The usual dose for adults (18 years and older) is:

- One inhalation ADVAIR DISKUS 250 twice daily
- or One inhalation ADVAIR DISKUS 500 twice daily

If you are troubled with mucus, try to clear your chest as completely as possible by coughing before you use ADVAIR DISKUS. This will allow ADVAIR DISKUS to pass more deeply into your lungs.

Overdose:

In case of drug overdose, contact a health care practitioner, hospital emergency department or regional Poison Control Centre immediately, even if there are no symptoms.

If you accidentally take a **larger dose than recommended**, you may notice that your heart is beating faster than usual and that you feel shaky. Other symptoms you may experience include headache, muscle weakness and aching joints.

Excessive use of medication can be extremely dangerous. If you have used a larger than allowed recommended dose of ADVAIR DISKUS for a long period of time (months or years), you should talk to your doctor or pharmacist for advice. A gradual reduction of your dose may be needed. Do not stop taking the medication suddenly.

Missed Dose:

It is **very important that you use ADVAIR DISKUS regularly**. If you forget to inhale a dose do not worry, inhale another as soon as you remember **but** if it is near to the time for the next dose, wait until it is due. Do not take a double dose. Then go on as before.

About your ADVAIR DISKUS:

The ADVAIR DISKUS inhaler is packaged in a plastic-coated, moisture-protective foil pouch. **Do not open the foil pouch until you are ready to use the inhaler.** When you take your DISKUS out of its foil pouch, it will be in the **closed position**. Safely throw away the pouch. Write the “Discard by” date in the first blank line on the label. This date is 1 month from the date you have opened the foil pouch.

The blisters protect the powder for inhalation from effects of the atmosphere.

A new DISKUS contains 28 or 60 individually protected doses of your medicine, in powder form. The device has a dose counter which tells you the number of doses remaining. It counts down from 28 or 60 to 1. **To show when the last five doses have been reached the numbers appear in red.**

Each dose is accurately measured and hygienically protected. The DISKUS requires no maintenance, and no refilling.

How to use your ADVAIR DISKUS properly:

It is important that you take each dose as instructed by your doctor, nurse, or pharmacist. Your doctor will decide which strength of DISKUS you should use.

When you need a dose, just follow the six simple steps illustrated: 1. Open, 2. Slide, 3. Exhale, 4. Inhale, 5. Close, 6. Rinse.

Sliding the lever of your DISKUS opens a small hole in the mouthpiece and unwraps a dose ready for you to inhale it. When you close the DISKUS, the lever automatically moves back to its original position ready for your next dose when you need it. The outer case protects your DISKUS when it is not in use.

1. Open

To open your DISKUS hold the outer case in one hand and put the thumb of your other hand on the thumb grip. Push the thumb grip away from you, until you hear it click into place.



2. Slide

Hold your DISKUS with the mouthpiece towards you. Slide the lever away until you hear another click. Your DISKUS is now ready to use.



Every time the lever is pushed back a dose is made available for inhaling. This is shown by the dose counter. Do not play with the lever as this releases doses which will be wasted.

3. Exhale

Hold the DISKUS away from your mouth. Breathe out as far as is comfortable. Remember – never exhale into your DISKUS.



4. Inhale

Before you start to inhale the dose, read through this section carefully. Once you have fully exhaled, place the mouthpiece to your mouth and close your lips around it. Breathe in steadily and deeply through your mouth until a full breath is taken.



Remove the DISKUS from your mouth. Hold your breath for 10 seconds or as long as is comfortable. **Breathe out slowly.**

You may not be able to taste or feel the powder on your tongue, even if you have used the DISKUS correctly.

5. Close

To close your DISKUS, place your thumb in the thumb grip, and slide it back until you hear a click. The lever is now automatically reset for your next use. The counter on the DISKUS indicates how many doses are remaining.



6. Rinse

Rinse out your mouth and gargle with water

after each dose. Do not swallow the water.

To get the most from your treatment, remember to take one inhalation of ADVAIR DISKUS twice a day, everyday or as prescribed by your doctor.



Special attention should be paid if you:

- were previously taking another form of corticosteroids (like an injection or an oral tablet) and have switched to an ICS, to look out for tiredness, weakness, nausea and vomiting, low blood pressure.
- are being treated for diabetes as you may need more frequent blood sugar monitoring or a dosage adjustment of your diabetes medication.
- develop a mild yeast infection of the mouth or throat (thrush, Candidiasis) or, rarely, in the esophagus. Common signs are white, slightly raised, sore patches on your tongue and inner cheeks. Remember to rinse and gargle your mouth with water and spit after using ADVAIR DISKUS. Cleaning dentures may also help.
- are a child or adolescent with asthma, as your growth should be monitored regularly by a physician when being treated with corticosteroids. Studies have also shown that children whose asthma is not controlled do not grow as quickly as other children.

SIDE EFFECTS AND WHAT TO DO ABOUT THEM

Medicines affect different people in different ways. Just because side effects have occurred in other patients does not mean you will get them. If you experience any side effects that bother you, please contact your doctor. This includes the following side effects, which usually wear off with continued treatment:

Effects on heart

- faster heart beat than usual

Effects on muscles and joints

- pain in joints
- muscle cramps

Effects on nervous system

- feeling a little shaky
- headache
- behavioural changes (including agitation, anxiety, and irritability)
- disturbed sleep
- fainting
- spinning sensation (vertigo)
- dizziness

Other Effects

- hoarseness and voice changes
- increased bruising

It is very important that you use your medicine regularly to control your asthma and to ask your doctor whether you need to be monitored in any special way.

SERIOUS SIDE EFFECTS, HOW OFTEN THEY HAPPEN AND WHAT TO DO ABOUT THEM

Symptom / effect		Talk with your doctor or pharmacist		Stop taking drug and seek immediate emergency medical attention
		Only if severe	In all cases	
Common	Thrush: yeast infection of the mouth or throat; thick white patches in the mouth, tongue or on the throat, sore throat		√	
	Pneumonia (in COPD patients), symptoms such as increased cough with increase in mucus (sputum) production, fever accompanied by shaking chills, shortness of breath, sharp or stabbing chest pain during deep breaths, and increased rapid breathing.*		√	
Uncommon	Allergic reactions: lumpy skin rash or hives anywhere on the body.			√
	Fast or irregular heartbeat that does not go away on its own		√	
	Increase amount of sugar in blood (excessive thirst, frequent urination, dry skin, blurred vision and fatigue)		√	
	Blurry vision or eye pain (cataracts)		√	

SERIOUS SIDE EFFECTS, HOW OFTEN THEY HAPPEN AND WHAT TO DO ABOUT THEM

Symptom / effect		Talk with your doctor or pharmacist		Stop taking drug and seek immediate emergency medical attention
		Only if severe	In all cases	
Rare	Eosinophilic granulomatosis with polyangiitis: a flu-like illness, rash, pins and needles or numbness of arms or legs, severe sinusitis and worsening lung or breathing problems		√	
	Low blood potassium: muscle weakness and muscle spasms		√	
	Rounded face, loss of bone density, blurry vision or eye pain (glaucoma), slowing of growth in children and adolescents		√	
	Decreased adrenal function: symptoms may include tiredness, weakness, nausea and vomiting, low blood pressure		√	
	Allergic reactions: sudden wheeziness and chest pain or tightness; or swelling of eyelids, face, lips, tongue or throat.			√
	Sudden worsening of shortness of breath and wheezing shortly after using ADVAIR DISKUS.			√

SERIOUS SIDE EFFECTS, HOW OFTEN THEY HAPPEN AND WHAT TO DO ABOUT THEM

Symptom / effect		Talk with your doctor or pharmacist		Stop taking drug and seek immediate emergency medical attention
		Only if severe	In all cases	
Rare	Mouth, throat becomes unusually irritated causing high pitched wheezing and choking		√	
	Esophageal candidiasis: Yeast infection of the esophagus (food tube); difficulty swallowing		√	
Very rare	Persistent pain and/or limited range of motion of a joint or a limb.		√	
Unknown	Decreased ability to fight infections. Symptoms of infection may include fever, pain, chills, feeling tired and sore throat	√		
	Worsening of lung symptoms such as increased shortness of breath, wheezing, cough and chest tightness accompanied by fever and more phlegm		√	

*Symptoms of pneumonia and COPD exacerbations frequently overlap.

This is not a complete list of side effects. For any unexpected effects while taking ADVAIR DISKUS, contact your doctor or pharmacist.

HOW TO STORE IT

Keep out of reach and sight of children. Your medicine may harm them.

Do not store ADVAIR DISKUS above 25°C. Keep in a dry place, away from direct heat or sunlight. Store ADVAIR DISKUS in the unopened foil pouch and only open when ready for use. Discard ADVAIR DISKUS 1 month after you open the foil pouch or when the counter reads 0, whichever comes first.

Remember

Keep your DISKUS dry and away from direct heat or sunlight. Keep it closed when not in use.

REPORTING SUSPECTED SIDE EFFECTS

You can report any suspected adverse reactions associated with the use of health products to the Canada Vigilance Program by one of the following 3 ways:

- Report online at <https://www.canada.ca/en/health-canada/services/drugs-health-products/medeffect-canada/adverse-reaction-reporting.html>
- Call toll-free at 1-866-234-2345
- Complete a Canada Vigilance Reporting Form and:
 - Fax toll-free to 1-866-678-6789, or
 - Mail to: **Canada Vigilance Program
Health Canada
Postal Locator 1908C
Ottawa, Ontario
K1A 0K9**

Postage paid labels, Canada Vigilance Reporting Form and the adverse reaction reporting guidelines are available on the MedEffect™ Canada Web site at <https://www.canada.ca/en/health-canada/services/drugs-health-products/medeffect-canada/adverse-reaction-reporting.html>.

NOTE: Should you require information related to the management of side effects, contact your health professional. The Canada Vigilance Program does not provide medical advice.

MORE INFORMATION

You may need to read this package insert again. **Please do not throw it away** until you have finished your medicine. This document plus the full product monograph, prepared for health professionals can be found at:

<http://www.gsk.ca> or by contacting the sponsor,
GlaxoSmithKline Inc., at:
7333 Mississauga Road
Mississauga, Ontario L5N 6L4
1-800-387-7374

This leaflet was prepared by GlaxoSmithKline Inc.

Last Revised: June 17, 2020

© 2020 GSK group of companies or its licensor
Trademarks are owned by or licensed to the GSK group of
companies.

PART III: CONSUMER INFORMATION

Pr **ADVAIR** **fluticasone propionate and salmeterol pressurised inhalation, suspension BP**

This leaflet is part III of a three-part "Product Monograph" for ADVAIR and is designed specifically for Consumers. This leaflet is a summary and will not tell you everything about ADVAIR. Contact your doctor or pharmacist if you have any questions about the drug.

ABOUT THIS MEDICATION

What the medication is used for:

Asthma (patients 12 years of age or older):

Asthma is a chronic inflammatory disease of the lungs characterized by episodes of difficulty in breathing. People with asthma have extra sensitive or "twitchy" airways. During an asthma attack, the airways react by narrowing, making it more difficult for the air to flow in and out of the lungs.

ADVAIR should be used in patients:

- who have asthma that is not adequately controlled with a long-term asthma medication such as an inhaled corticosteroid (ICS) alone; or
- whose asthma severity requires treatment with both an ICS and long-acting beta₂ agonist (LABA).

ADVAIR should not be the first asthma medication you use unless advised by your doctor. It is only used when a regular ICS medicine along with a fast acting 'reliever' medicine, such as salbutamol are not adequately helping you with your breathing problems. ADVAIR helps to prevent breathlessness and wheezing from happening due to asthma.

Control of asthma requires avoiding irritants that cause asthma attacks and taking the appropriate medications. For example, patients should avoid exposure to house dust mites, mold, pets, tobacco smoke and pollens.

This medicine is for you. Only a doctor can prescribe it for you. Never give it to someone else. It may harm them even if their symptoms are the same as yours.

What it does:

ADVAIR contains two medicinal ingredients, fluticasone propionate and salmeterol xinafoate.

Fluticasone propionate is an inhaled corticosteroid. Corticosteroids are used to treat breathing problems because they have an anti-inflammatory action. They reduce the swelling and irritation in the walls of the small air passages in the lungs and so ease breathing problems.

Salmeterol xinafoate is a LABA. It relaxes the muscles in the walls of the small air passages in the lungs. This helps to open the airways and makes it easier for air to get in and out of the lungs. The effects of salmeterol xinafoate last for at least 12 hours. When it is taken regularly with an inhaled corticosteroid it helps the small air passages to remain open.

Corticosteroids also help to prevent attacks of asthma. When you take these two ingredients together regularly they will both help to control your breathing difficulties.

When it should not be used:

ADVAIR does not act quickly enough to provide relief from a sudden attack of breathlessness or wheezing. A fast acting 'reliever' medicine, such as salbutamol should be used for any sudden attacks of breathlessness or wheezing (e.g., asthma attacks).

Do not use ADVAIR if you:

- Are allergic or have had an allergic reaction to fluticasone propionate, salmeterol xinafoate.
- Have a medical history of cardiac tachyarrhythmias (problems of your heart beating fast and/or irregularly).
- Have an untreated fungal, bacterial or tuberculosis infection.

What the medicinal ingredients are:

fluticasone propionate and salmeterol xinafoate.

What the nonmedicinal ingredients are:

CFC-free propellant, HFA.

What dosage forms it comes in:

ADVAIR pressurised inhalation, suspension is a pressurized metered dose inhaler containing 125 or 250 mcg of fluticasone propionate, and 25 mcg of salmeterol per inhalation.

WARNINGS AND PRECAUTIONS

ADVAIR is not for the treatment of acute asthma attacks.

If you get a sudden attack of wheezing and breathlessness between your doses of ADVAIR, you should use your fast acting 'reliever' medicine, such as salbutamol which your doctor has prescribed to you. Use the medication as directed by your doctor.

You may need to also take steroid tablets or syrup during a severe asthma attack, during other illnesses or during times of stress. Your doctor may give you some steroid tablets or syrup to carry with you as well as a steroid warning card, which will give you advice on when and how to use them.

Before and while you use ADVAIR talk to your doctor or pharmacist if the following situations apply to you so that they can determine whether you should start or continue taking this medication:

- Have eye problems such as glaucoma, cataracts, blurry vision or other changes in vision.
- Are suffering from any chest infection (cold, bronchitis).
- Have ever had to stop taking another medication for your breathing problems because you were allergic to it or it caused problems.
- Ever had a yeast infection (thrush) in your mouth.
- Are having treatment for a thyroid condition.
- Have diabetes.
- Have high blood pressure.
- Have heart problems.
- Have had tuberculosis (TB) infections.
- Are taking other “steroids” by mouth or by inhalation.
- Are pregnant, planning to become pregnant or breastfeeding.
- Are taking a medicine called ketoconazole, used to treat fungal infection.
- Are taking medicines used to treat HIV infection (e.g. ritonavir, atazanavir, indinavir, nelfinavir, saquinavir and cobicistat containing products).
- Have liver problems or cirrhosis.

You should avoid coming into contact with anyone who has measles or the chicken pox while taking an ICS. If you or your child are exposed, tell your doctor right away.

Drugs like ADVAIR can cause eye disorders:

- Cataracts: Clouding of the lens in the eye, blurry vision, eye pain;
- Glaucoma: An increased pressure in your eyes, eye pain. Untreated, it may lead to permanent vision loss;
- Central serous chorioretinopathy (CSCR): blurry vision or other changes in vision.

Contact your healthcare professional if you experience blurry vision or other vision problems. You should have regular eye exams.

Asthma:

After you start taking ADVAIR, your doctor may change the dosages of your other asthma medicines. Rarely, this may make a patient feel worse rather than better. This especially applies to oral corticosteroids (sometimes referred to as steroids), including prednisone. If your doctor decreases your oral steroid dose, and you become unwell, tell your doctor immediately.

You should have your asthma assessed at regular intervals as agreed upon with your doctor. Once control of your asthma is achieved and maintained, your doctor may further adjust your

dose of ADVAIR. Do not stop or change the dose of your ADVAIR unless your doctor has advised you to do so.

When LABA medicines are used alone without an ICS, they increase the risk of hospitalization and death from asthma problems. ADVAIR contains both an ICS and LABA. Studies showed that when an ICS and LABA are used together, there is not a significant increased risk in hospitalizations and death from asthma problems.

Tell your doctor immediately if:

- There is a change in your symptoms such as more coughing, attacks of wheezing, chest tightness, or an unusual increase in the severity of the breathlessness.
- You wake up at night with chest tightness, wheezing or shortness of breath.
- You use increasing amounts of your fast acting ‘reliever’ medicine.

These could be warning signs that your condition may be worsening. Do not stop taking ADVAIR without talking to your doctor.

INTERACTIONS WITH THIS MEDICATION

As with most medicines, interactions with other drugs are possible. Tell your doctor, nurse, or pharmacist about all the medicines you take, including drugs prescribed by other doctors, vitamins, minerals, natural supplements, or alternative medicines.

Drugs that may interact with ADVAIR include:

- medicines similar to ADVAIR used for your lung disease, as it may increase the risk of experiencing possible side effects. This includes other medicines containing a LABA or a corticosteroid.
- medicines used to treat HIV infection or AIDS (e.g. ritonavir, atazanavir, indinavir, nelfinavir, saquinavir and cobicistat containing products).
- ketoconazole (used to treat fungal infections).
- beta-blockers used in the treatment of high blood pressure or other heart problems (e.g. propranolol) or in the treatment of glaucoma.
- medicines used to treat depression (i.e., tricyclic antidepressants, monoamine oxidase inhibitors).
- medicines used to decrease the level of potassium in your blood (i.e., diuretics). These are also known as “water pills” and are used to treat high blood pressure.
- methylxanthines (such as theophylline) used to treat asthma.

PROPER USE OF THIS MEDICATION

It is very important that you use 2 puffs of ADVAIR every day, twice a day, even if you have no symptoms. This will help you to keep free of symptoms throughout the day and night. **You should not use it more than twice a day.** If you take more than one inhaled medicine, make sure you understand the purpose for taking each medication and when you should use them.

It is very important that you use ADVAIR regularly every day. Do not stop taking ADVAIR suddenly, even if you feel better. Your doctor can provide you with information about how to slowly stop the medication if necessary. Do not change your dose unless told to by your doctor. If you have to go into hospital for an operation, take your ADVAIR with you and tell the doctor what medicine(s) you are taking. If your doctor decides to stop the treatment, do not keep any left-over medicine unless your doctor tells you to.

Spacer devices (holding chamber) may be used in patients who have difficulty coordinating the actuation of a metered dose inhaler with inhalation. Talk to your doctor before using ADVAIR with a spacer device because your dose may need to

be changed. If using a spacer device, follow the manufacturer’s instructions.

Usual Asthma Dose:

For patients 12 years of age and older, the usual dose is:
Two inhalations ADVAIR 125 pressurized inhalation, suspension twice daily
or
Two inhalations ADVAIR 250 pressurized inhalation, suspension twice daily.

At present, there are insufficient clinical data to recommend the use of ADVAIR in children younger than 12 years of age.

Overdose:

In case of drug overdose, contact a health care practitioner, hospital emergency department or regional Poison Control Centre immediately, even if there are no symptoms.

If you accidentally take a **larger dose than recommended**, you may notice that your heart is beating faster than usual and that you feel shaky. Other symptoms you may experience include headache, muscle weakness and aching joints.

Excessive use of medication can be extremely dangerous. If you have used a larger than allowed recommended dose of ADVAIR for a long period of time (months or years), you should talk to your doctor or pharmacist for advice. A gradual reduction of your dose may be needed. Do not stop taking the medication suddenly.

Missed Dose:

It is **very important that you use ADVAIR regularly**. If you forget to inhale a dose do not worry, inhale another as soon as you remember **but** if it is near to the time for the next dose, wait until it is due. Do not take a double dose. Then go on as before.

How to Prime ADVAIR:

Before you use your ADVAIR for the first time, remove the mouthpiece cover by gently squeezing the sides of the cover, shake the inhaler well and release a puff into the air and repeat until the counter reads 120 to make sure that it works. If your inhaler has not been used for a week or more, remove the mouthpiece cover, shake the inhaler well and release a puff into the air; repeat for a second puff. Each time the inhaler is activated, the number on the counter will count down by one after each actuation. In some circumstances, dropping the inhaler may cause the counter to count down.

How to use your ADVAIR properly:

It is important that you take each dose as instructed by your doctor, nurse, or pharmacist. Your doctor will decide which

strength of ADVAIR you should use.

After use, always replace the mouthpiece cover immediately to keep out dust and fluff. **REPLACE MOUTHPIECE COVER FIRMLY AND PUSH INTO POSITION.** The cover must be replaced in the correct orientation; otherwise, the cover will not fit properly. Do not force; the cover will click into position if it is replaced in the correct orientation. If the cover is upside down, it will not be possible to fully replace it. If this happens, remove the cover, rotate it and try again.

1. Open

To remove the snap-on mouthpiece cover, hold between the thumb and forefinger, squeeze gently and pull apart as shown. Check inside and outside of the inhaler including the mouthpiece for the presence of loose objects. Your inhaler is now ready to use.

2. Shake

Shake the inhaler well to ensure that any loose objects are removed and that the contents of the inhaler are evenly mixed.

3. Exhale

Hold the inhaler upright between your fingers and thumb with your thumb on the base, below the mouthpiece. Breathe out as far as is comfortable. Once you have fully exhaled, place the mouthpiece between your teeth without biting, and close your lips around it.

4. Inhale

Just after starting to breathe in through your mouth, press down firmly on the top of the inhaler while still breathing in steadily and deeply.

Remove the inhaler from your mouth and hold your breath for 10 seconds or as long as is comfortable. **Breathe out slowly.**

Each time the inhaler is activated, the number on the counter will count down by one.

Each prescribed dose is usually given by a minimum of 2 puffs. Before taking your next puff, hold the inhaler upright and wait 30 seconds before repeating steps 2 through 4.



To keep out dust and lint, replace the mouthpiece cover by firmly pushing and snapping the cover into position in the correct orientation. If it does not click into place, turn the cover the other way round and try again. Do not use excessive force.

5. Rinse

Rinse out your mouth and gargle with water after each dose. Do not swallow the water.



To get the most from your treatment, remember to take 2 puffs of ADVAIR twice a day, every day or as prescribed by your doctor.

Important

Do not rush stage 4. It is important that you start to breathe in as slowly as possible just before operating your inhaler. Practice in front of a mirror for the first few times. If you see "mist" coming from the top of your inhaler or the sides of your mouth, you should start again from stage 2.

If your doctor has given you different instructions for using your inhaler, please follow them carefully. Tell your doctor if you have any difficulties.

You should get a replacement when the counter shows the number 020. The counter will stop at 000 when all of the recommended puffs have been used. Stop using the inhaler when the counter reads 000.



Never try to alter the numbers on the counter or detach the counter from the metal can. The counter cannot be reset and is permanently attached to the can.

Children/Elderly

Some children may need help and an adult may need to operate the inhaler for them. Encourage the child to breathe out and operate the inhaler just after the child starts to breathe in. Practice the technique together. Children or people with weak hands should hold the inhaler with both hands. Put the two forefingers on top of the inhaler and both thumbs on the base below the mouthpiece.

Cleaning

To prevent your inhaler blocking up, it is important to clean it at least once a week, following the instructions below. If your inhaler does block up, the same cleaning instructions should be followed. If you notice a build up of medicine around the mouthpiece, do not attempt to unblock it with a sharp object, such as a pin.

To clean your inhaler:

1. Remove the mouthpiece cover.
2. Do not remove the canister from the plastic casing.
3. Wipe the inside and outside of the mouthpiece and the plastic casing with a dry cloth, tissue or cotton swab. Do not put the metal canister into water.
4. Replace the mouthpiece cover.

SIDE EFFECTS AND WHAT TO DO ABOUT THEM

Medicines affect different people in different ways. Just because side effects have occurred in other patients does not mean you will get them. If you experience any side effects that bother you, please contact your doctor. This includes the following side effects, which usually wear off with continued treatment:

Effects on heart

- faster heart beat than usual

Effects on muscles and joints

- pain in joints
- muscle cramps

Effects on nervous system

- feeling a little shaky
- headache
- behavioural changes (including agitation, anxiety, and irritability)
- disturbed sleep
- fainting
- spinning sensation (vertigo)
- dizziness

Other Effects

- hoarseness and voice changes
- increased bruising

It is very important that you use your medicine regularly to control your asthma and to ask your doctor whether you need to be monitored in any special way.

Special attention should be paid if you:

- were previously taking another form of corticosteroids (like an injection or an oral tablet) and have switched to an ICS, to look out for tiredness, weakness, nausea and vomiting, low blood pressure.
- are being treated for diabetes as you may need more frequent blood sugar monitoring or a dosage adjustment of your diabetes medication.
- develop a mild yeast infection of the mouth or throat (thrush, Candidiasis) or, rarely, in the esophagus. Common signs are white, slightly raised, sore patches on your tongue and inner cheeks. Remember to rinse and gargle your mouth with water and spit after using ADVAIR. Cleaning dentures may also help.
- are a child or adolescent with asthma, as your growth should be monitored regularly by a physician when being treated with corticosteroids. Studies have also shown that children whose asthma is not controlled do not grow as quickly as other children.

SERIOUS SIDE EFFECTS, HOW OFTEN THEY HAPPEN AND WHAT TO DO ABOUT THEM

Symptom / effect		Talk with your doctor or pharmacist		Stop taking drug and seek immediate emergency medical attention
		Only if severe	In all cases	
Common	Thrush: yeast infection of the mouth or throat; thick white patches in the mouth, tongue or on the throat, sore throat		√	
	Pneumonia (in COPD patients), symptoms such as increased cough with increase in mucus (sputum) production, fever accompanied by shaking chills, shortness of breath, sharp or stabbing chest pain during deep breaths, and increased rapid breathing.*		√	
Uncommon	Allergic reactions: lumpy skin rash or hives anywhere on the body.			√
	Fast or irregular heartbeat that does not go away on its own		√	
	Increase amount of sugar in blood (excessive thirst, frequent urination, dry skin, blurred vision and fatigue)		√	
	Blurry vision or eye pain (cataracts)		√	

SERIOUS SIDE EFFECTS, HOW OFTEN THEY HAPPEN AND WHAT TO DO ABOUT THEM

Symptom / effect		Talk with your doctor or pharmacist		Stop taking drug and seek immediate emergency medical attention
		Only if severe	In all cases	
Rare	Eosinophilic granulomatosis with polyangiitis: a flu-like illness, rash, pins and needles or numbness of arms or legs, severe sinusitis and worsening lung or breathing problems		√	
	Low blood potassium: muscle weakness and muscle spasms		√	
	Rounded face, loss of bone density, blurry vision or eye pain (glaucoma), slowing of growth in children and adolescents		√	
	Decreased adrenal function: symptoms may include tiredness, weakness, nausea and vomiting, low blood pressure		√	
	Allergic reactions: sudden wheeziness and chest pain or tightness; or swelling of eyelids, face, lips, tongue or throat.			√
	Sudden worsening of shortness of breath and wheezing shortly after using ADVAIR.			√

SERIOUS SIDE EFFECTS, HOW OFTEN THEY HAPPEN AND WHAT TO DO ABOUT THEM

Symptom / effect		Talk with your doctor or pharmacist		Stop taking drug and seek immediate emergency medical attention
		Only if severe	In all cases	
Rare	Mouth, throat becomes unusually irritated causing high pitched wheezing and choking		√	
	Esophageal candidiasis: Yeast infection of the esophagus (food tube); difficulty swallowing		√	
Very rare	Persistent pain and/or limited range of motion of a joint or a limb.		√	
Unknown	Decreased ability to fight infections. Symptoms of infection may include fever, pain, chills, feeling tired and sore throat	√		
	Worsening of lung symptoms such as wheezing, shortness of breath, cough and chest tightness		√	

*Symptoms of pneumonia and COPD exacerbations frequently overlap.

This is not a complete list of side effects. For any unexpected effects while taking ADVAIR, contact your doctor or pharmacist.

HOW TO STORE IT

Keep out of reach and sight of children. Your medicine may harm them.

After use, replace the mouthpiece cover firmly and snap it into position. Do not use excessive force.

Store ADVAIR between 15°C and 25°C. Protect from frost and direct sunlight.

As with most inhaled medications in pressurized canisters, the therapeutic effect of this medication may decrease when the canister is cold. If the inhaler becomes very cold, remove the metal canister and warm **in your hand** for a few minutes. **Never** use other forms of heat.

Warning - The metal canister is pressurized. Do not puncture it or burn it, even when apparently empty.

REPORTING SUSPECTED SIDE EFFECTS

You can report any suspected adverse reactions associated with the use of health products to the Canada Vigilance Program by one of the following 3 ways:

- Report online at <https://www.canada.ca/en/health-canada/services/drugs-health-products/medeffect-canada/adverse-reaction-reporting.html>
- Call toll-free at 1-866-234-2345
- Complete a Canada Vigilance Reporting Form and:
 - Fax toll-free to 1-866-678-6789, or
 - Mail to: **Canada Vigilance Program
Health Canada
Postal Locator 1908C
Ottawa, Ontario
K1A 0K9**

Postage paid labels, Canada Vigilance Reporting Form and the adverse reaction reporting guidelines are available on the MedEffect™ Canada Web site at <https://www.canada.ca/en/health-canada/services/drugs-health-products/medeffect-canada/adverse-reaction-reporting.html>.

NOTE: Should you require information related to the management of side effects, contact your health professional. The Canada Vigilance Program does not provide medical advice.

MORE INFORMATION

You may need to read this package insert again. **Please do not throw it away** until you have finished your medicine. This document plus the full product monograph, prepared for health professionals can be found at:

<http://www.gsk.ca> or by contacting the sponsor, GlaxoSmithKline Inc., at:
7333 Mississauga Road
Mississauga, Ontario L5N 6L4
1-800-387-7374

This leaflet was prepared by GlaxoSmithKline Inc.

Last Revised: June 17, 2020

© 2020 GSK group of companies or its licensor
Trademarks are owned by or licensed to the GSK group of companies.



Outside View

ADVAIR DISKUS[®] 100/50
(fluticasone propionate 100 mcg and salmeterol* 50 mcg inhalation powder)

Remember:

- Always use the DISKUS in a level, flat position.
- Make sure the lever firmly clicks into place.
- Hold your breath for about 10 seconds after inhaling. Then breathe out fully.
- After each dose, rinse your mouth with water and spit it out. Do not swallow the water.
- Do not take an extra dose, even if you did not taste or feel the powder.
- Do not take the DISKUS apart.
- Do not wash the DISKUS.
- Always keep the DISKUS in a dry place.
- Do not use the DISKUS with a spacer device.

For live assistance with using your ADVAIR DISKUS, call 1-800-884-0593. Visit www.advair.com

NDC 0173-0695-00

ADVAIR DISKUS[®] 100/50
(fluticasone propionate 100 mcg and salmeterol* 50 mcg inhalation powder)

FOR ORAL INHALATION ONLY

*Each blister contains 100 mcg of fluticasone propionate and 72.5 mcg of salmeterol xinafoate, equivalent to 50 mcg of salmeterol base, with lactose.

Federal Law requires the dispensing of ADVAIR DISKUS with the Medication Guide inside the carton.

Rx only



100/50

1 DISKUS[®] Inhalation Device
Containing 1 Foil Strip of 60 Blisters

Store at room temperature between 68°F and 77°F (20°C and 25°C); excursions permitted from 59°F to 86°F (15°C to 30°C) [See USP Controlled Room Temperature]. Store in a dry place away from direct heat or sunlight. **Keep out of reach of children.** Discard ADVAIR DISKUS 1 month after opening the foil pouch or when the counter reads "0" (after all blisters have been used), whichever comes first. **Dosage:** Use only as directed by your doctor.

IMPORTANT: Read the accompanying Medication Guide leaflet carefully for further information. ©2015, the GSK group of companies GlaxoSmithKline Research Triangle Park, NC 27709

For FREE information, please visit our website at **advair.com**
Or call 888-825-5249



DEVCOMP-0004264 Rev. 8/15

DEVCOMP-0004264

Instructions for using ADVAIR DISKUS
Read the Medication Guide that comes with ADVAIR DISKUS before you start using it and each time you get a refill. There may be new information.

- Step 1. Open your ADVAIR DISKUS.**
Hold the DISKUS in your left hand. Place the thumb of your right hand in the thumb grip and push it away from you as far as it will go until the mouthpiece snaps into place.
- Step 2. Slide the lever until you hear it click.**
Hold the DISKUS in a level, flat position with the mouthpiece towards you. Slide the lever away from the mouthpiece as far as it will go until it clicks.
- Step 3. Inhale your medicine.**
Breathe out (exhale) as long as you can while you hold the DISKUS level and away from your mouth. Do not breathe into the mouthpiece.
Put the mouthpiece to your lips. Breathe in quickly and deeply through the DISKUS. Do not breathe in through your nose.
Remove the DISKUS from your mouth and **hold your breath for about 10 seconds**, or for as long as is comfortable for you.
Breathe out slowly as long as you can.
- Step 4. Close the DISKUS.** Make sure the DISKUS clicks shut and you cannot see the mouthpiece.
- Step 5. Rinse your mouth with water after breathing in the medicine.** Spit out the water. Do not swallow it.

Continued on side panel.

Inside View

Scan this code using your smart phone to see instructions on how to use your ADVAIR DISKUS device.



<http://gsk.ly/htudvid>

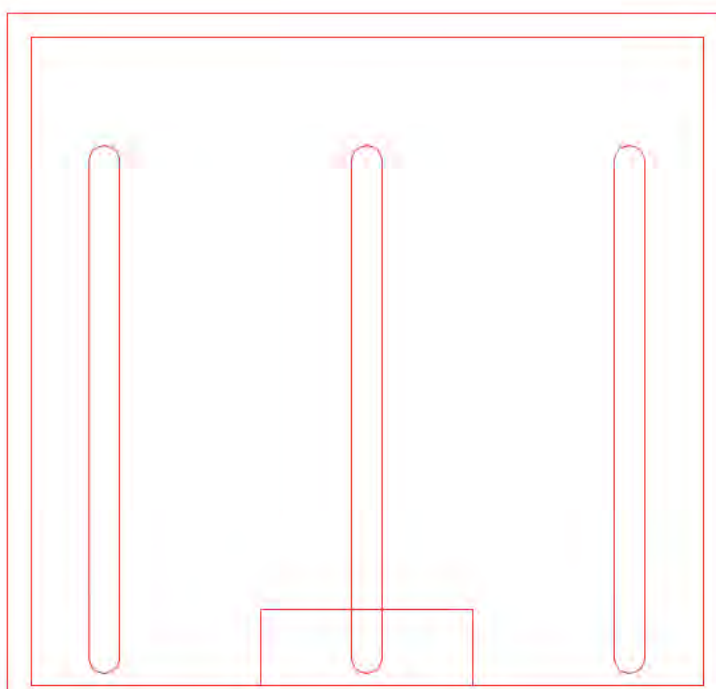



Outside View

ADVAIR DISKUS[®] 100/50
(fluticasone propionate 100 mcg and salmeterol* 50 mcg inhalation powder)

Remember:

- Always use the DISKUS in a level, flat position.
- Make sure the lever firmly clicks into place.
- Hold your breath for about 10 seconds after inhaling. Then breathe out fully.
- After each dose, rinse your mouth with water and spit it out. Do not swallow the water.
- Do not take an extra dose, even if you did not taste or feel the powder.
- Do not take the DISKUS apart.
- Do not wash the DISKUS.
- Always keep the DISKUS in a dry place.
- Do not use the DISKUS with a spacer device.

For live assistance with using your ADVAIR DISKUS, call 1-800-884-0593. Visit www.advair.com

NDC 0173-0695-04

ADVAIR DISKUS[®] 100/50
(fluticasone propionate 100 mcg and salmeterol* 50 mcg inhalation powder)

FOR ORAL INHALATION ONLY

*Each blister contains 100 mcg of fluticasone propionate and 72.5 mcg of salmeterol xinafoate, equivalent to 50 mcg of salmeterol base, with lactose.

Federal Law requires the dispensing of ADVAIR DISKUS with the Medication Guide inside the carton.

Rx only

INSTITUTIONAL PACK

100/50

1 DISKUS[®] Inhalation Device
Containing 1 Foil Strip of 14 Blisters

Store at room temperature between 68°F and 77°F (20°C and 25°C); excursions permitted from 59°F to 86°F (15°C to 30°C) [See USP Controlled Room Temperature]. Store in a dry place away from direct heat or sunlight. **Keep out of reach of children.** Discard ADVAIR DISKUS 1 month after opening the foil pouch or when the counter reads "0" (after all blisters have been used), whichever comes first. **Dosage:** Use only as directed by your doctor.

IMPORTANT: Read the accompanying Medication Guide leaflet carefully for further information.

©2015, the GSK group of companies
GlaxoSmithKline
Research Triangle Park, NC 27709

For FREE information, please visit our website at advair.com
Or call 888-825-5249

Instructions for using ADVAIR DISKUS
Read the Medication Guide that comes with ADVAIR DISKUS before you start using it and each time you get a refill. There may be new information.

- Step 1. Open your ADVAIR DISKUS.**
Hold the DISKUS in your left hand. Place the thumb of your right hand in the thumb grip and push it away from you as far as it will go until the mouthpiece snaps into place.
- Step 2. Slide the lever until you hear it click.**
Hold the DISKUS in a level, flat position with the mouthpiece towards you. Slide the lever away from the mouthpiece as far as it will go until it clicks.
- Step 3. Inhale your medicine.**
Breathe out (exhale) as long as you can while you hold the DISKUS level and away from your mouth. Do not breathe into the mouthpiece.
Put the mouthpiece to your lips. Breathe in quickly and deeply through the DISKUS. Do not breathe in through your nose.
Remove the DISKUS from your mouth and **hold your breath for about 10 seconds**, or for as long as is comfortable for you.
Breathe out slowly as long as you can.

The DISKUS delivers your dose of medicine as a very fine powder that you may or may not taste or feel. **Do not** take an extra dose from the DISKUS even if you do not taste or feel the medicine.

- Step 4. Close the DISKUS.** Make sure the DISKUS clicks shut and you cannot see the mouthpiece.
- Step 5. Rinse your mouth with water after breathing in the medicine.** Spit out the water. Do not swallow it.

Continued on side panel.

Inside View

Scan this code using your smart phone to see instructions on how to use your ADVAIR DISKUS device.



<http://gsk.ly/htudvid>

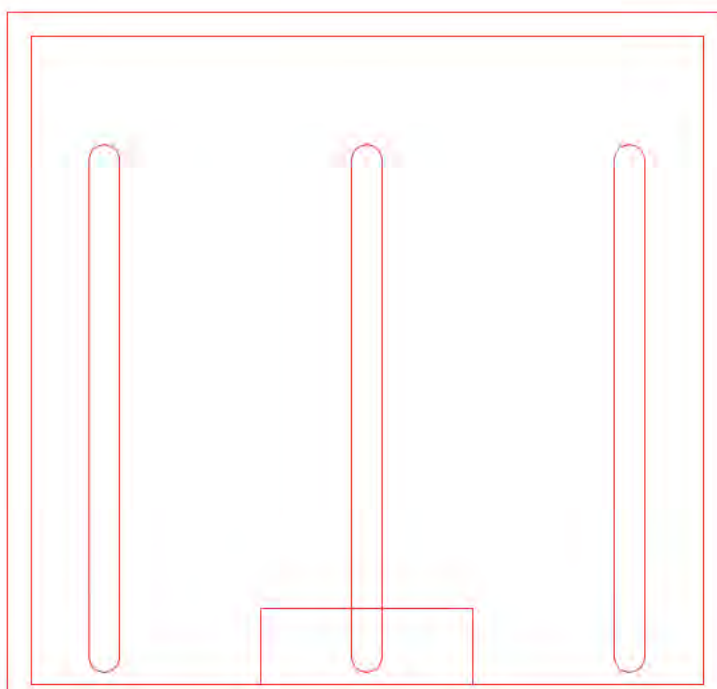







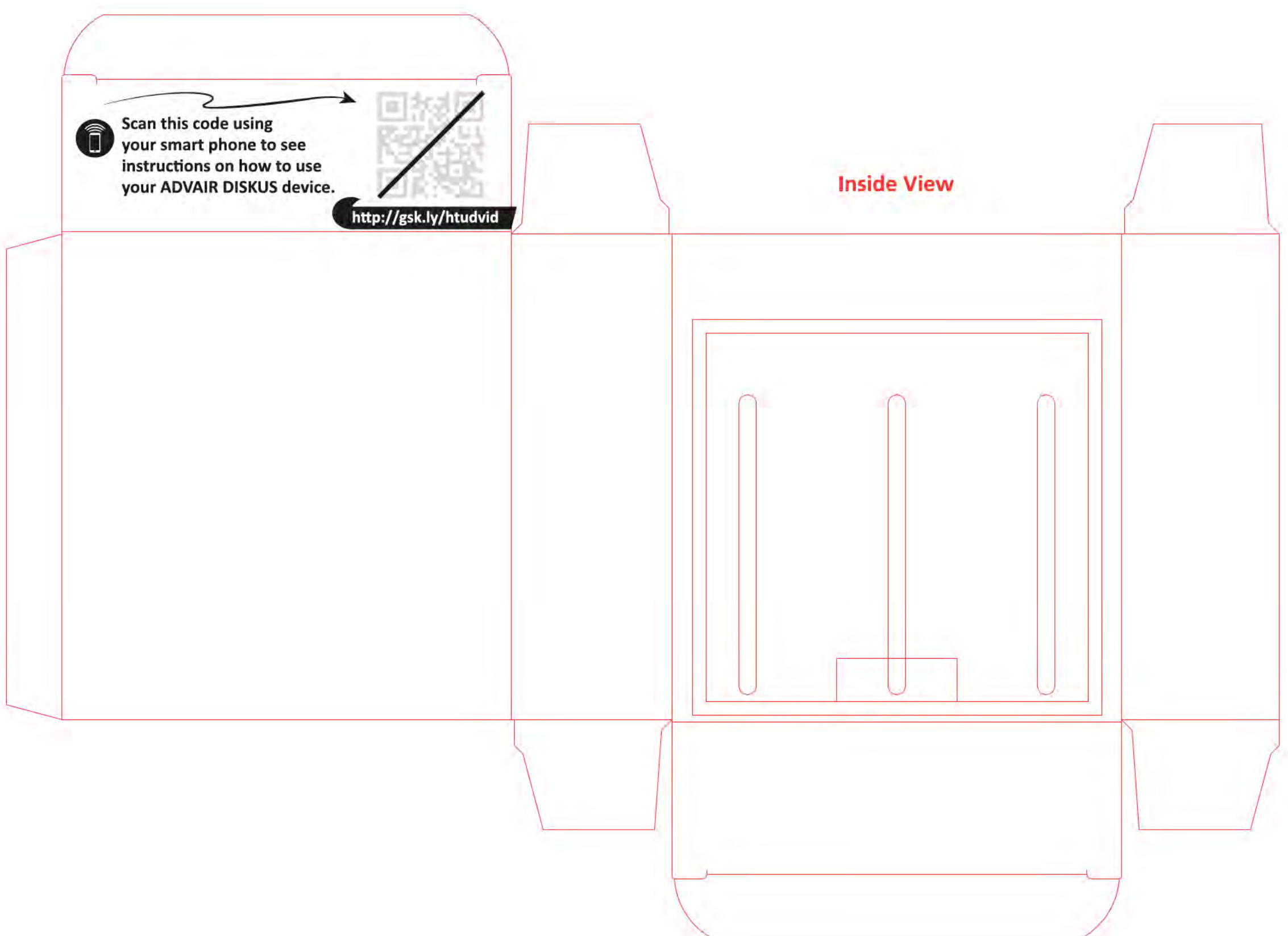
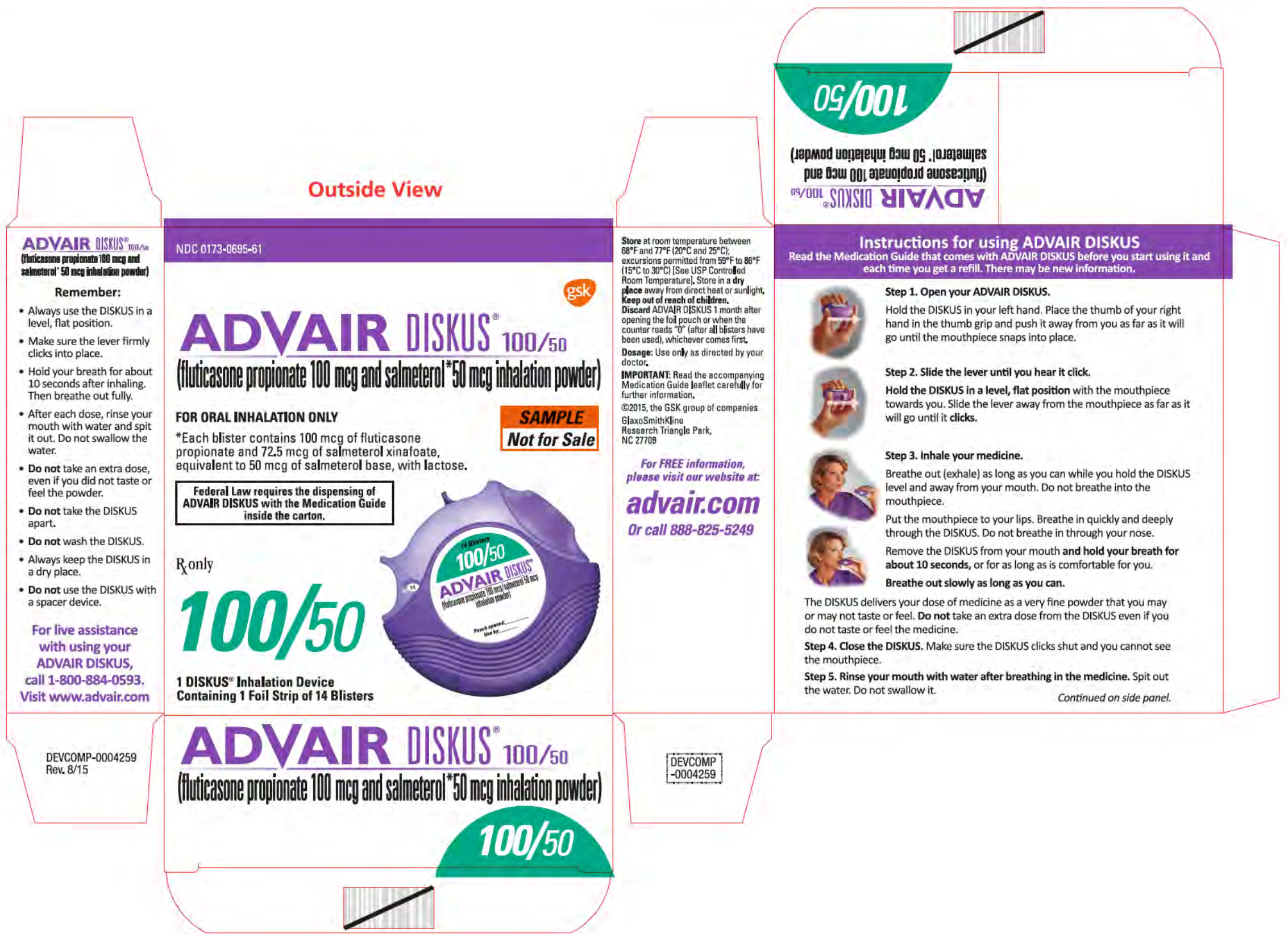



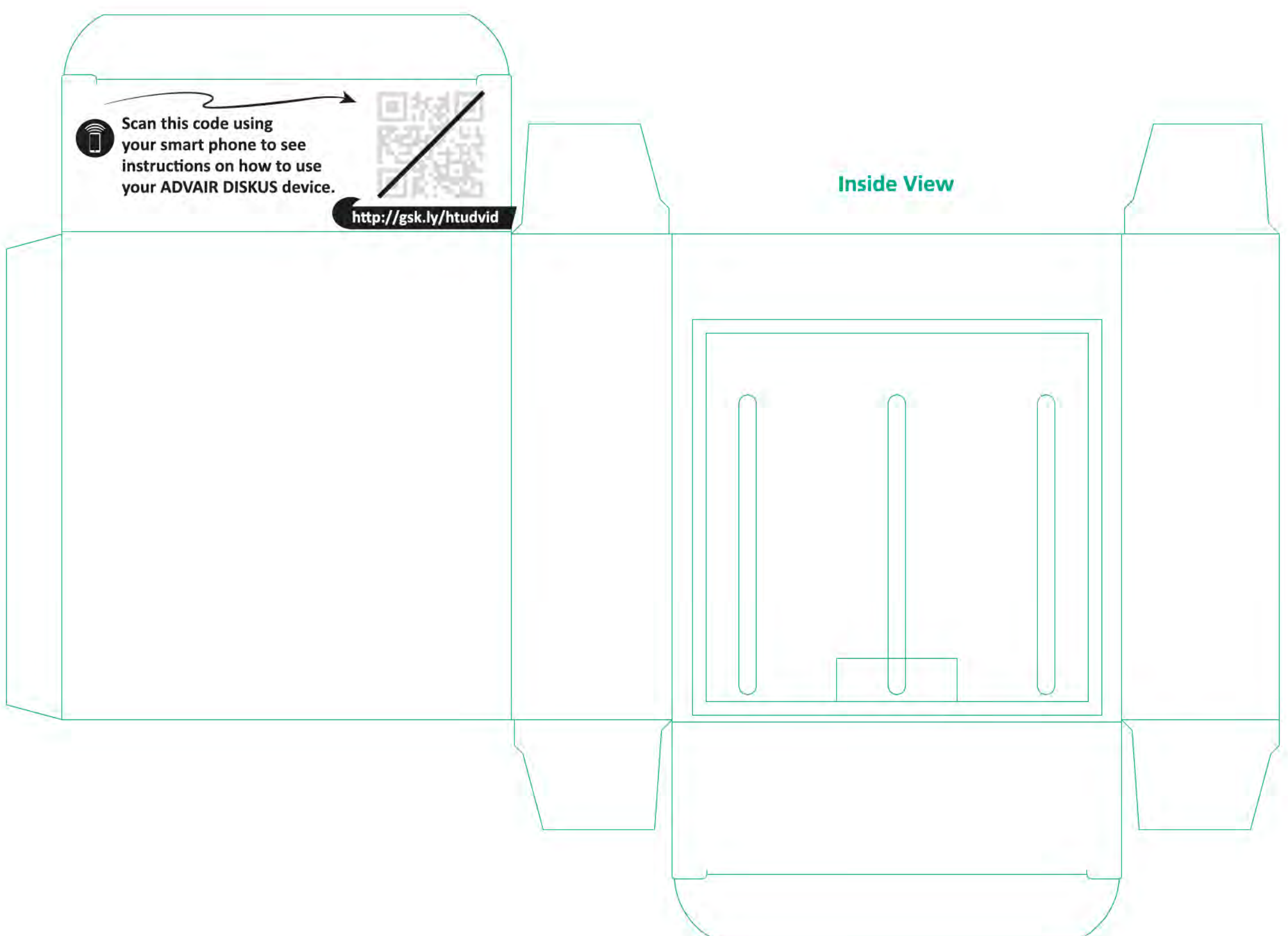



Outside View

ADVAIR DISKUS[®] 250/50
(fluticasone propionate 250 mcg and salmeterol* 50 mcg inhalation powder)

NDC 0173-0696-04

Remember:

- Always use the DISKUS in a level, flat position.
- Make sure the lever firmly clicks into place.
- Hold your breath for about 10 seconds after inhaling. Then breathe out fully.
- After each dose, rinse your mouth with water and spit it out. Do not swallow the water.
- Do not take an extra dose, even if you did not taste or feel the powder.
- Do not take the DISKUS apart.
- Do not wash the DISKUS.
- Always keep the DISKUS in a dry place.
- Do not use the DISKUS with a spacer device.

For live assistance with using your ADVAIR DISKUS, call 1-800-884-0593. Visit www.advair.com

ADVAIR DISKUS[®] 250/50
(fluticasone propionate 250 mcg and salmeterol* 50 mcg inhalation powder)

FOR ORAL INHALATION ONLY

*Each blister contains 250 mcg of fluticasone propionate and 72.5 mcg of salmeterol xinafoate, equivalent to 50 mcg of salmeterol base, with lactose.

Federal Law requires the dispensing of ADVAIR DISKUS with the Medication Guide inside the carton.

Rx only

INSTITUTIONAL PACK

250/50

1 DISKUS[®] Inhalation Device
Containing 1 Foil Strip of 14 Blisters

Store at room temperature between 68°F and 77°F (20°C and 25°C); excursions permitted from 59°F to 86°F (15°C to 30°C) (See USP Controlled Room Temperature). Store in a dry place away from direct heat or sunlight. Keep out of reach of children. Discard ADVAIR DISKUS 1 month after opening the foil pouch or when the counter reads "0" (after all blisters have been used), whichever comes first. Dosage: Use only as directed by your doctor. **IMPORTANT:** Read the accompanying Medication Guide leaflet carefully for further information. ©2015, the GSK group of companies GlaxoSmithKline Research Triangle Park, NC 27709

For FREE information, please visit our website at advair.com
Or call 888-825-5249

Instructions for using ADVAIR DISKUS
Read the Medication Guide that comes with ADVAIR DISKUS before you start using it and each time you get a refill. There may be new information.

Step 1. Open your ADVAIR DISKUS.
Hold the DISKUS in your left hand. Place the thumb of your right hand in the thumb grip and push it away from you as far as it will go until the mouthpiece snaps into place.

Step 2. Slide the lever until you hear it click.
Hold the DISKUS in a level, flat position with the mouthpiece towards you. Slide the lever away from the mouthpiece as far as it will go until it clicks.

Step 3. Inhale your medicine.
Breathe out (exhale) as long as you can while you hold the DISKUS level and away from your mouth. Do not breathe into the mouthpiece.
Put the mouthpiece to your lips. Breathe in quickly and deeply through the DISKUS. Do not breathe in through your nose.
Remove the DISKUS from your mouth and hold your breath for about 10 seconds, or for as long as is comfortable for you.
Breathe out slowly as long as you can.

The DISKUS delivers your dose of medicine as a very fine powder that you may or may not taste or feel. Do not take an extra dose from the DISKUS even if you do not taste or feel the medicine.

Step 4. Close the DISKUS. Make sure the DISKUS clicks shut and you cannot see the mouthpiece.

Step 5. Rinse your mouth with water after breathing in the medicine. Spit out the water. Do not swallow it.

Continued on side panel.

DEVCOMP-0004257 Rev. 8/15

DEVCOMP-0004257

Inside View

Scan this code using your smart phone to see instructions on how to use your ADVAIR DISKUS device.

<http://gsk.ly/htudvid>







Outside View

ADVAIR DISKUS[®] 250/50
(fluticasone propionate 250 mcg and salmeterol* 50 mcg inhalation powder)

Remember:

- Always use the DISKUS in a level, flat position.
- Make sure the lever firmly clicks into place.
- Hold your breath for about 10 seconds after inhaling. Then breathe out fully.
- After each dose, rinse your mouth with water and spit it out. Do not swallow the water.
- Do not take an extra dose, even if you did not taste or feel the powder.
- Do not take the DISKUS apart.
- Do not wash the DISKUS.
- Always keep the DISKUS in a dry place.
- Do not use the DISKUS with a spacer device.

For live assistance with using your ADVAIR DISKUS, call 1-800-884-0593. Visit www.advair.com

NDC 0173-0696-61

ADVAIR DISKUS[®] 250/50
(fluticasone propionate 250 mcg and salmeterol* 50 mcg inhalation powder)

FOR ORAL INHALATION ONLY

*Each blister contains 250 mcg of fluticasone propionate and 72.5 mcg of salmeterol xinafoate, equivalent to 50 mcg of salmeterol base, with lactose.

Federal Law requires the dispensing of ADVAIR DISKUS with the Medication Guide inside the carton.

Rx only

250/50

1 DISKUS[®] Inhalation Device
Containing 1 Foil Strip of 14 Blisters

gsk

SAMPLE
Not for Sale



Store at room temperature between 68°F and 77°F (20°C and 25°C); excursions permitted from 59°F to 86°F (15°C to 30°C) (See USP Controlled Room Temperature). Store in a dry place away from direct heat or sunlight. **Keep out of reach of children.** Discard ADVAIR DISKUS 1 month after opening the foil pouch or when the counter reads "0" (after all blisters have been used), whichever comes first.

Dosage: Use only as directed by your doctor.

IMPORTANT: Read the accompanying Medication Guide leaflet carefully for further information.

©2015, the GSK group of companies
GlaxoSmithKline
Research Triangle Park,
NC 27709

For **FREE** information, please visit our website at **advair.com**
Or call 888-825-5249

DEVCMP-0004260 Rev. 8/15

DEVCMP-0004260

Instructions for using ADVAIR DISKUS
Read the Medication Guide that comes with ADVAIR DISKUS before you start using it and each time you get a refill. There may be new information.

- Step 1. Open your ADVAIR DISKUS.**
Hold the DISKUS in your left hand. Place the thumb of your right hand in the thumb grip and push it away from you as far as it will go until the mouthpiece snaps into place.
- Step 2. Slide the lever until you hear it click.**
Hold the DISKUS in a level, flat position with the mouthpiece towards you. Slide the lever away from the mouthpiece as far as it will go until it clicks.
- Step 3. Inhale your medicine.**
Breathe out (exhale) as long as you can while you hold the DISKUS level and away from your mouth. Do not breathe into the mouthpiece.
Put the mouthpiece to your lips. Breathe in quickly and deeply through the DISKUS. Do not breathe in through your nose.
Remove the DISKUS from your mouth and **hold your breath for about 10 seconds**, or for as long as is comfortable for you.
Breathe out slowly as long as you can.
- Step 4. Close the DISKUS.** Make sure the DISKUS clicks shut and you cannot see the mouthpiece.
- Step 5. Rinse your mouth with water after breathing in the medicine.** Spit out the water. Do not swallow it.

Continued on side panel.

Inside View

Scan this code using your smart phone to see instructions on how to use your ADVAIR DISKUS device.



<http://gsk.ly/htudvid>

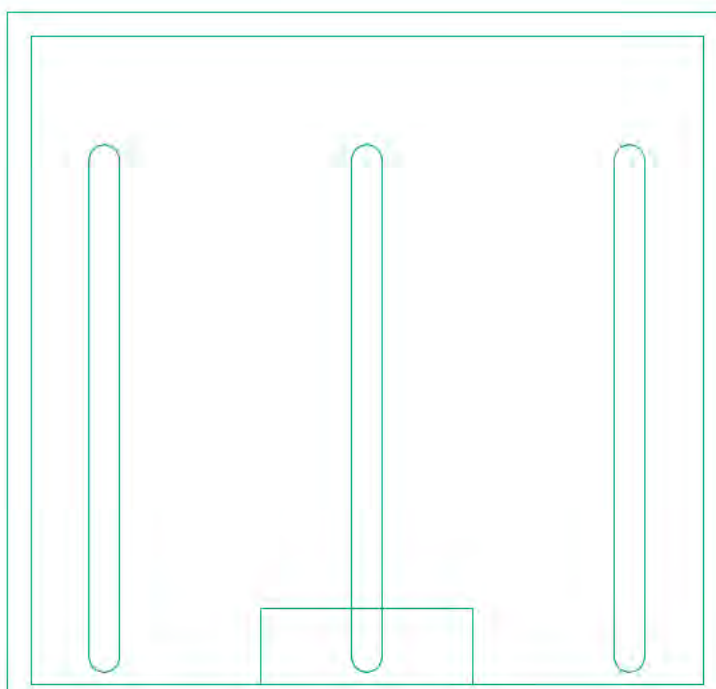



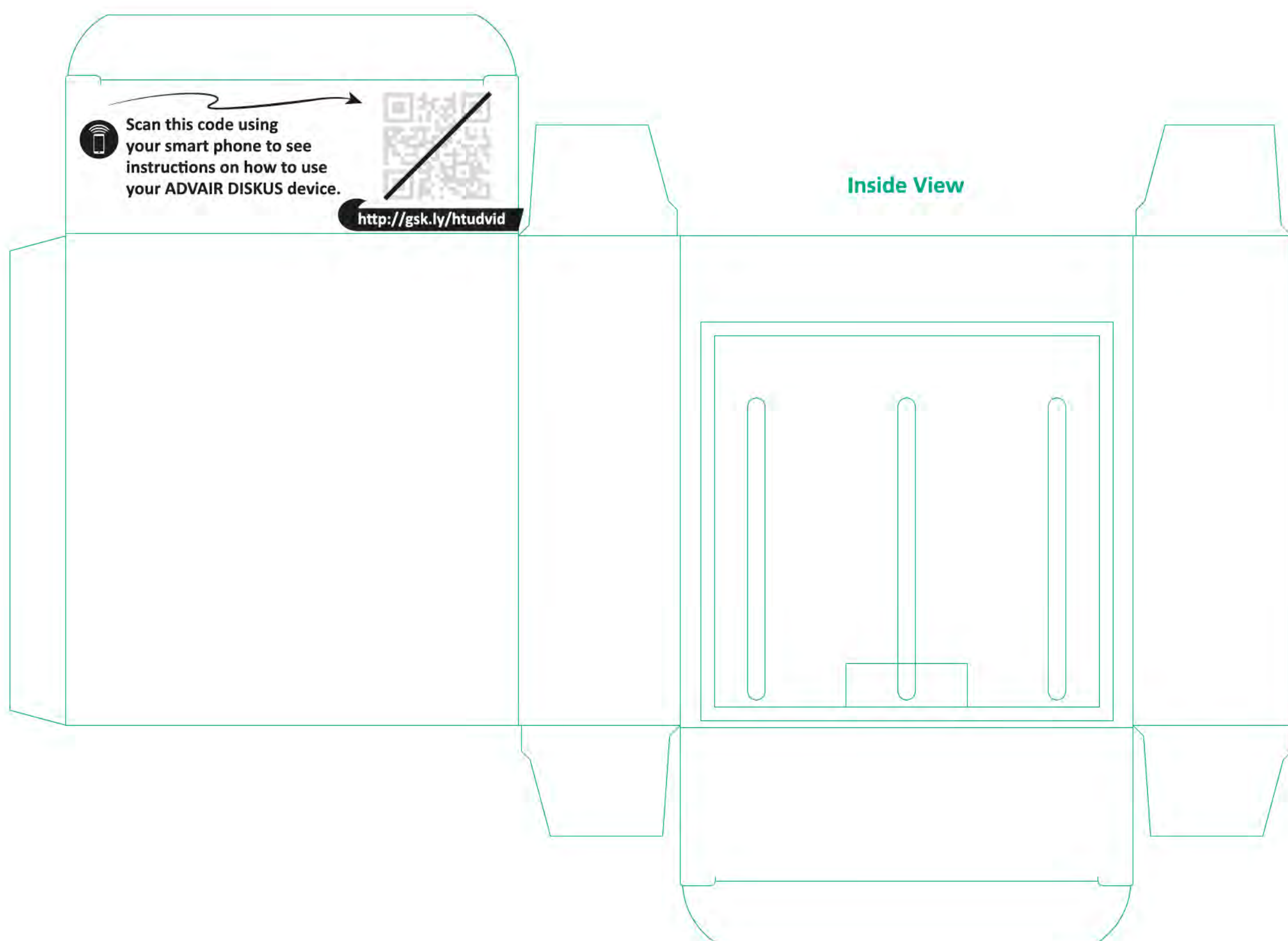

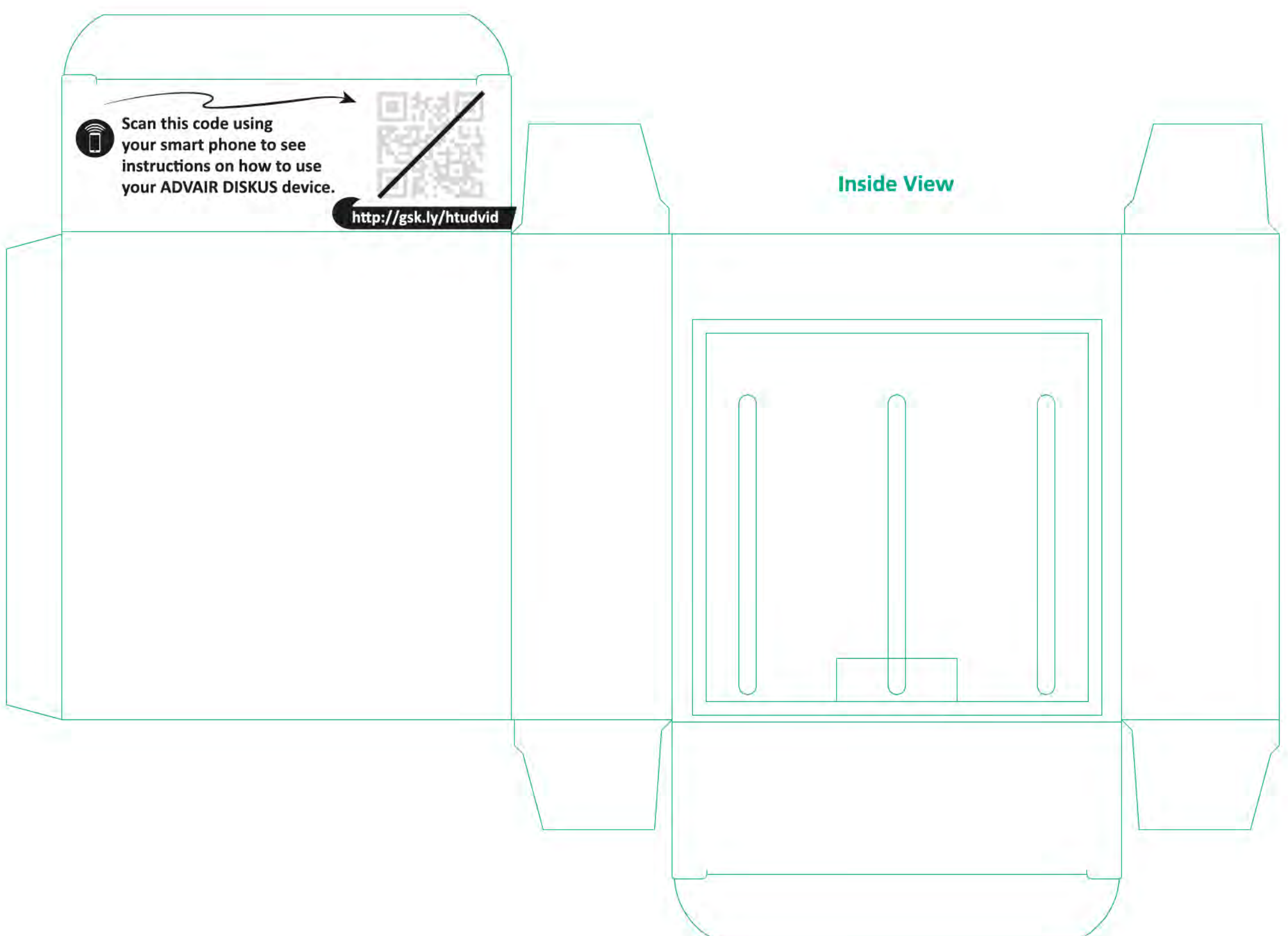







Outside View

ADVAIR DISKUS[®] 500/50
(fluticasone propionate 500 mcg and salmeterol* 50 mcg inhalation powder)

Remember:

- Always use the DISKUS in a level, flat position.
- Make sure the lever firmly clicks into place.
- Hold your breath for about 10 seconds after inhaling. Then breathe out fully.
- After each dose, rinse your mouth with water and spit it out. Do not swallow the water.
- **Do not** take an extra dose, even if you did not taste or feel the powder.
- **Do not** take the DISKUS apart.
- **Do not** wash the DISKUS.
- Always keep the DISKUS in a dry place.
- **Do not** use the DISKUS with a spacer device.

For live assistance with using your ADVAIR DISKUS, call 1-800-884-0593. Visit www.advair.com

NDC 0173-0697-61

ADVAIR DISKUS[®] 500/50
(fluticasone propionate 500 mcg and salmeterol* 50 mcg inhalation powder)

FOR ORAL INHALATION ONLY

*Each blister contains 500 mcg of fluticasone propionate and 72.5 mcg of salmeterol xinafoate, equivalent to 50 mcg of salmeterol base, with lactose.

Federal Law requires the dispensing of ADVAIR DISKUS with the Medication Guide inside the carton.

Rx only

500/50

1 DISKUS[®] Inhalation Device
Containing 1 Foil Strip of 14 Blisters

gsk

SAMPLE
Not for Sale



Store at room temperature between 68°F and 77°F (20°C and 25°C); excursions permitted from 59°F to 86°F (15°C to 30°C) [See USP Controlled Room Temperature]. Store in a dry place away from direct heat or sunlight. **Keep out of reach of children.** Discard ADVAIR DISKUS 1 month after opening the foil pouch or when the counter reads "0" (after all blisters have been used), whichever comes first.

IMPORTANT: Read the accompanying Medication Guide leaflet carefully for further information.

©2015, the GSK group of companies
GlaxoSmithKline
Research Triangle Park,
NC 27709

For **FREE** information, please visit our website at **advair.com**
Or call 888-825-5249

DEVCOMP-0004261 Rev. 8/15

DEVCOMP-0004261

500/50

ADVAIR DISKUS[®] 500/50
(fluticasone propionate 500 mcg and salmeterol* 50 mcg inhalation powder)

Instructions for using ADVAIR DISKUS
Read the Medication Guide that comes with ADVAIR DISKUS before you start using it and each time you get a refill. There may be new information.

- Step 1. Open your ADVAIR DISKUS.**
Hold the DISKUS in your left hand. Place the thumb of your right hand in the thumb grip and push it away from you as far as it will go until the mouthpiece snaps into place.
- Step 2. Slide the lever until you hear it click.**
Hold the DISKUS in a level, flat position with the mouthpiece towards you. Slide the lever away from the mouthpiece as far as it will go until it clicks.
- Step 3. Inhale your medicine.**
Breathe out (exhale) as long as you can while you hold the DISKUS level and away from your mouth. Do not breathe into the mouthpiece.
Put the mouthpiece to your lips. Breathe in quickly and deeply through the DISKUS. Do not breathe in through your nose.
Remove the DISKUS from your mouth and **hold your breath for about 10 seconds**, or for as long as is comfortable for you.
Breathe out slowly as long as you can.
- Step 4. Close the DISKUS.** Make sure the DISKUS clicks shut and you cannot see the mouthpiece.
- Step 5. Rinse your mouth with water after breathing in the medicine.** Spit out the water. Do not swallow it.

Continued on side panel.

Scan this code using your smart phone to see instructions on how to use your ADVAIR DISKUS device.



<http://gsk.ly/htudvid>

Inside View

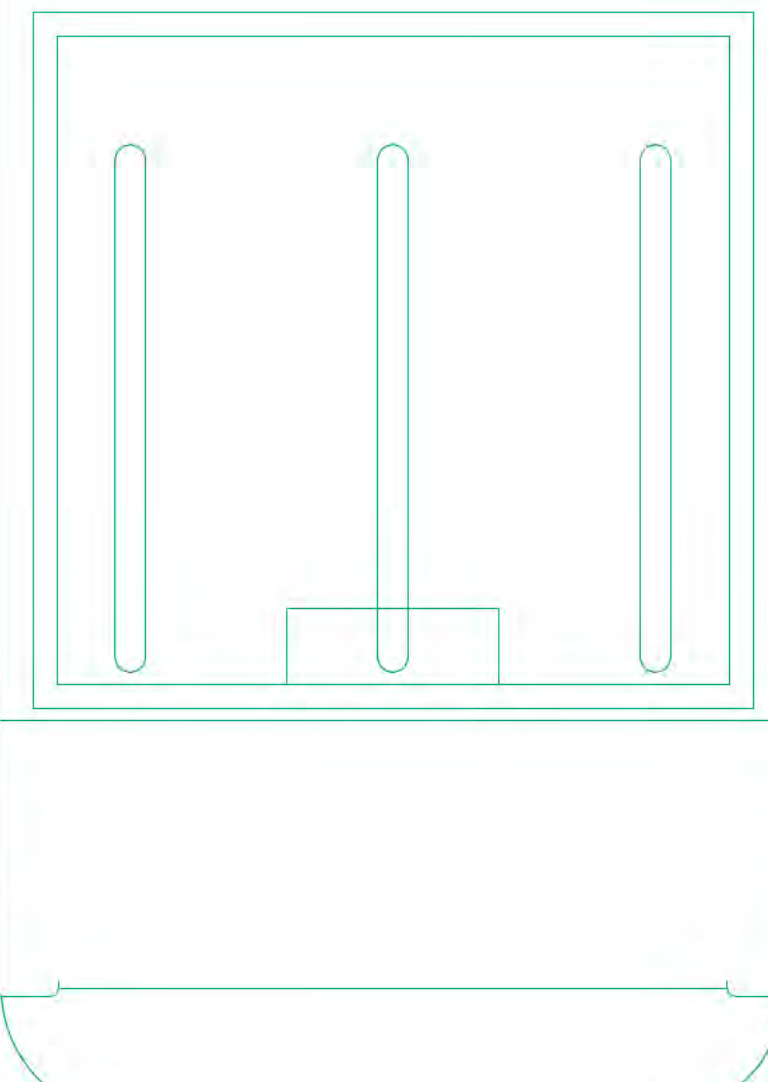



PRODUCT MONOGRAPH

Pr **AFINITOR**[®]
(everolimus tablets)
2.5 mg, 5 mg, 7.5 mg and 10 mg

Pr **AFINITOR**[®] **DISPERZ**[™]
(everolimus tablets for oral suspension)
2 mg, 3 mg and 5 mg

Antineoplastic Agent
(mTOR kinase inhibitor)

Novartis Pharmaceuticals Canada Inc.
385 Bouchard Blvd., Dorval, Quebec
H9S 1A9

Date of Revision:
November 16, 2017

Submission Control No: 200814

AFINITOR is a registered trademark.

Table of Contents

PART I: HEALTH PROFESSIONAL INFORMATION.....3
SUMMARY PRODUCT INFORMATION3
INDICATIONS AND CLINICAL USE.....3
CONTRAINDICATIONS6
WARNINGS AND PRECAUTIONS.....6
ADVERSE REACTIONS.....15
DRUG INTERACTIONS42
DOSAGE AND ADMINISTRATION45
OVERDOSAGE57
ACTION AND CLINICAL PHARMACOLOGY57
STORAGE AND STABILITY61
SPECIAL HANDLING INSTRUCTIONS61
DOSAGE FORMS, COMPOSITION AND PACKAGING61

PART II: SCIENTIFIC INFORMATION63
PHARMACEUTICAL INFORMATION.....63
CLINICAL TRIALS.....64
DETAILED PHARMACOLOGY90
TOXICOLOGY94
REFERENCES103

PART III: CONSUMER INFORMATION.....106

Pr **AFINITOR**[®]
(everolimus tablets)

Pr **AFINITOR**[®] **DISPERZ**[™]
(everolimus tablets for oral suspension)

PART I: HEALTH PROFESSIONAL INFORMATION

SUMMARY PRODUCT INFORMATION

Route of Administration	Dosage Form / Strength	Clinically Relevant Nonmedicinal Ingredients
AFINITOR [®]		
Oral	Tablet 2.5 mg, 5 mg, 7.5 mg and 10 mg	Butylated hydroxytoluene (E321), crospovidone, hypromellose, lactose anhydrous, lactose monohydrate, magnesium stearate. <i>For a complete listing see Dosage Forms, Composition and Packaging section.</i>
AFINITOR [®] DISPERZ [™]		
Oral	Tablet for oral suspension 2 mg, 3 mg and 5 mg	Butylated hydroxytoluene (E321), cellulose microcrystalline, crospovidone, hypromellose, lactose monohydrate, magnesium stearate, mannitol, silica colloidal anhydrous. <i>For a complete listing see Dosage Forms, Composition and Packaging section.</i>

INDICATIONS AND CLINICAL USE

AFINITOR[®] (everolimus) is indicated for the treatment of postmenopausal women with hormone receptor-positive, HER2- negative advanced breast cancer in combination with exemestane after recurrence or progression following treatment with letrozole or anastrozole.

The effectiveness of AFINITOR in advanced breast cancer is based on a demonstration of progression-free survival (PFS) benefit. Clinical benefit such as prolongation of overall survival (OS) or improvement in quality-of-life (QOL) has not been demonstrated (see **CLINICAL TRIALS**).

AFINITOR is indicated for the treatment of well- or moderately differentiated neuroendocrine

tumours of pancreatic origin (PNET) in patients with unresectable, locally advanced or metastatic disease that has progressed within the last 12 months.

The effectiveness of AFINITOR in PNET is based on demonstrated progression-free survival (PFS) benefit in a phase III placebo-controlled study in patients with documented progressive disease within 12 months of randomization. There was no evidence of an overall survival (OS) benefit and quality of life (QOL) was not measured (see **CLINICAL TRIALS**).

AFINITOR is indicated for the treatment of unresectable, locally advanced or metastatic, well-differentiated, non-functional neuroendocrine tumours (NET) of gastrointestinal or lung origin in adults with progressive disease.

The effectiveness of AFINITOR in gastrointestinal or lung NET is based on demonstrated progression-free survival (PFS) benefit in a phase III placebo-controlled study in patients whose disease had progressed within 6 months of randomization. An overall survival (OS) benefit or improvement in quality of life (QOL) has not been demonstrated. Subgroup analyses suggested that patients with better prognosis benefited less from AFINITOR treatment (see **CLINICAL TRIALS**).

AFINITOR in combination with a somatostatin analogue is not indicated for the treatment of patients with neuroendocrine tumours from gastrointestinal or lung origin.

AFINITOR is not indicated for the treatment of patients with functional carcinoid tumours (see **WARNINGS AND PRECAUTIONS** and **CLINICAL TRIALS**).

AFINITOR is indicated for the treatment of patients with metastatic renal cell carcinoma (RCC) of clear cell morphology, after failure of initial treatment with either of the VEGF-receptor TKIs¹ sunitinib or sorafenib.

The effectiveness of AFINITOR is based on PFS. Prolongation of OS was not demonstrated for AFINITOR in RCC nor were quality-of-life differences shown between patients receiving AFINITOR versus placebo in the pivotal phase III trial (see **CLINICAL TRIALS**).

AFINITOR and AFINITOR DISPERZ are indicated for the treatment of patients with subependymal giant cell astrocytoma (SEGA) associated with tuberous sclerosis complex (TSC) that have demonstrated serial growth, who are not candidates for surgical resection and for whom immediate surgical intervention is not required.

The effectiveness of AFINITOR is based on an analysis of change in SEGA volume.

Prescribers should take into consideration that surgical resection can be curative, while treatment with AFINITOR has been shown only to reduce the SEGA volume.

¹ VEGF receptor TKIs = vascular endothelial growth factor receptor tyrosine kinase inhibitors

The pharmacokinetic properties of AFINITOR and AFINITOR DISPERZ have been evaluated in clinical comparative bioavailability trials (see **ACTION AND CLINICAL PHARMACOLOGY, Pharmacokinetics**). AFINITOR DISPERZ has **not** been studied in clinical safety and efficacy trials.

AFINITOR is indicated for the treatment of adult patients (≥ 18 years of age) with renal angiomyolipoma associated with tuberous sclerosis complex (TSC), who do not require immediate surgery.

The effectiveness of AFINITOR in the treatment of renal angiomyolipoma is based on an analysis of objective responses in patients treated for a median of 8.3 months in the pivotal phase III placebo-controlled trial (see **CLINICAL TRIALS**).

AFINITOR DISPERZ is indicated as adjunctive treatment of seizures associated with Tuberous Sclerosis Complex (TSC) in patients 2 years and older, with a definite diagnosis of TSC, who are not satisfactorily controlled with current therapies.

Only patients with a definite diagnosis of TSC participated in the seizures related clinical trial. Therefore, AFINITOR DISPERZ should not be used for the treatment of any type of seizure in any other patient population (see **CONTRAINDICATIONS** and **CLINICAL TRIALS**).

AFINITOR DISPERZ is the only formulation that should be used for the treatment of patients with seizures associated with TSC.

Geriatrics (≥ 65 years of age):

In the advanced breast cancer study, 40% of AFINITOR-treated patients were ≥ 65 years of age, while 15% were 75 years of age and over. No overall differences in effectiveness were observed between elderly and younger patients. Differences in the incidence of deaths due to any cause within 28 days of the last AFINITOR dose and in the incidence of adverse reactions leading to permanent treatment discontinuation were observed between elderly and younger patients (see **WARNINGS AND PRECAUTIONS, Special Populations, Geriatrics** and **CLINICAL TRIALS**).

In two other randomized trials (metastatic RCC and advanced PNET), no overall differences in safety or effectiveness were observed between elderly and younger patients. In the randomized metastatic RCC study, 41% of AFINITOR treated patients were ≥ 65 years of age, while 7% were 75 years of age and over. In the randomized advanced PNET study, 30% of AFINITOR -treated patients were ≥ 65 years of age, while 7% were 75 years of age and over (see **CLINICAL TRIALS**).

In the randomized advanced GI/Lung NET study, 47% of AFINITOR -treated patients were ≥ 65 years of age, while 16% were 75 years of age and above. No overall differences in effectiveness were observed between elderly and younger patients. Adverse events reported with 1.5-fold the incidence in older patients receiving everolimus relative to those aged <65 years included cardiac failure, lower respiratory tract infections (pneumonia, lung infection, bronchitis), cough and

decreased appetite.

Paediatrics (< 18 years of age):

AFINITOR is not recommended for use in paediatric cancer patients.

AFINITOR and AFINITOR DISPERZ have not been studied in paediatric patients with SEGA < 1 year of age and are not recommended for use in this age group. There are limited efficacy and safety data in patients 1 to 3 years of age with AFINITOR in patients with SEGA (see **WARNINGS AND PRECAUTIONS, Special Populations**).

AFINITOR DISPERZ has not been studied in paediatric patients <2 years of age with seizures associated with TSC and is not recommended for use in this age group.

AFINITOR and AFINITOR DISPERZ are not recommended for use in paediatric patients with renal angiomyolipoma.

CONTRAINDICATIONS

- AFINITOR (everolimus) and AFINITOR DISPERZ are contraindicated in patients who are hypersensitive to the drug, to other rapamycin derivatives or to any of the excipients. For a complete listing, see the **DOSAGE FORMS, COMPOSITION AND PACKAGING** (see also **WARNINGS AND PRECAUTIONS**).
- AFINITOR (everolimus) and AFINITOR DISPERZ are contraindicated for the treatment of seizures (of any type) in populations other than those with a definite diagnosis of TSC (see **CLINICAL TRIALS**).

WARNINGS AND PRECAUTIONS

Serious Warnings and Precautions

Hormone receptor-positive, HER2-negative advanced breast cancer, advanced NET and metastatic kidney cancer:

- AFINITOR (everolimus) should be prescribed by a qualified healthcare professional who is experienced in the use of antineoplastic therapy.

SEGA associated with TSC:

- Treatment with AFINITOR or AFINITOR DISPERZ should be initiated by a qualified healthcare professional experienced in the treatment of patients with TSC and with access to everolimus therapeutic drug monitoring services.
- Therapeutic drug monitoring of everolimus blood concentrations is **required** for patients treated for SEGA (see **DOSAGE AND ADMINISTRATION, Therapeutic drug monitoring for patients treated for SEGA**).
- The optimal duration of AFINITOR therapy for patients with SEGA is not known; however, SEGA re-growth has been reported to occur once therapy is discontinued (see

DOSAGE AND ADMINISTRATION, SEGA volume monitoring for patients treated with AFINITOR and CLINICAL TRIALS, SEGA associated with Tuberous Sclerosis Complex).

- Non-clinical data suggests that there is a risk of delayed developmental landmarks and delayed reproductive development in patients taking everolimus (see **Special Populations, Paediatrics** below and **TOXICOLOGY**).
- Dosage forms (AFINITOR and AFINITOR DISPERZ™) are **not** interchangeable (see **DOSAGE AND ADMINISTRATION, Dosing Considerations, Switching dosage forms**)

Renal Angiomyolipoma associated with TSC:

- Treatment with AFINITOR should be initiated by a qualified healthcare professional experienced in the treatment of patients with TSC. The optimal time to initiate therapy is not known.
- The optimal duration of AFINITOR therapy for patients who have renal angiomyolipoma associated with TSC is not known (see **CLINICAL TRIALS, Renal Angiomyolipoma associated with Tuberous Sclerosis Complex**).
- Clinical trial data suggest that there is a potential risk of secondary amenorrhoea in females taking everolimus (see **Special Populations, Women of childbearing potential** below).

The following are clinically significant adverse events:

- Non-infectious pneumonitis, including fatalities (see “**Respiratory**” section below)
- Infections, including fatalities (see “**Immune**” section below)
- Renal failure, including fatalities (see “**Renal**” section below)

General

Drug-Drug Interactions

Co-administration with strong inhibitors of CYP3A4 and/or PgP should be avoided (see **DOSAGE AND ADMINISTRATION** and **DRUG INTERACTIONS**).

Use caution when administered in combination with moderate inhibitors of CYP3A4 and/or PgP. If AFINITOR or AFINITOR DISPERZ must be co-administered with a moderate inhibitor of CYP3A4 and/or PgP, the patient should be carefully monitored for undesirable effects and the dose reduced (see **DOSAGE AND ADMINISTRATION** and **DRUG INTERACTIONS**).

Co-administration with strong inducers of CYP3A4 and/or PgP should be avoided due to the risk of reduced effectiveness of the drug. If AFINITOR or AFINITOR DISPERZ must be co-administered with a strong inducer of CYP3A4 and/or PgP, the patient should be carefully monitored for clinical response. Consider a dose increase of AFINITOR or AFINITOR DISPERZ when co-administered with anticonvulsants that are strong inducers of CYP3A4 if alternative treatment is not possible. However, there are limited clinical data with this dose adjustment in patients with renal angiomyolipoma receiving an anticonvulsant that is a strong inducer of CYP3A4 (see **DOSAGE AND ADMINISTRATION** and **DRUG INTERACTIONS**).

Exercise caution when AFINITOR or AFINITOR DISPERZ is taken in combination with orally administered CYP3A4 substrates with a narrow therapeutic index due to the potential for drug interactions that may increase blood levels of CYP3A4 substrates. Interaction between AFINITOR or AFINITOR DISPERZ and non-orally administered CYP3A4 substrates has not been studied (see **DRUG INTERACTIONS**).

Patients taking concomitant ACE inhibitor therapy may be at increased risk for angioedema (e.g. swelling of the airways or tongue, with or without respiratory impairment). A review of pooled clinical trial data in the oncology setting revealed that angioedema occurred in 3.2% and 2.9% of everolimus patients treated with concomitant ACE inhibitors during double-blind and open-label treatment, respectively. In contrast, angioedema occurred in 0.5% and 0.7% of everolimus patients NOT treated with ACE inhibitors, in double-blind and open-label treatment, respectively.

Carcinogenesis and Mutagenesis

Genotoxicity studies showed no evidence of clastogenic or mutagenic activity. Administration of everolimus for up to 2 years did not indicate any oncogenic potential in mice and rats up to the highest doses, corresponding respectively to 3.9 and 0.2 times the estimated clinical exposure from a 10 mg daily dose.

Functional carcinoid tumour

In a randomized, double-blind, multi-centre trial in 429 patients with functional carcinoid tumours, AFINITOR plus depot octreotide (SANDOSTATIN[®] LAR[®]) was compared to placebo plus depot octreotide. The study did not meet the primary efficacy endpoint (PFS) and the OS interim analysis numerically favoured the placebo plus depot octreotide arm. Therefore, the use of AFINITOR in patients with functional carcinoid tumours is not recommended outside an investigational study.

Endocrine and Metabolism

Hyperlipidaemia: Hypercholesterolaemia and hypertriglyceridaemia have been reported in patients taking AFINITOR (see **ADVERSE REACTIONS**). Monitoring of fasting lipid profile is recommended prior to the start of AFINITOR or AFINITOR DISPERZ therapy and periodically thereafter. Consider dose reduction, dose interruption or discontinuation, as well as management with appropriate medical therapy (see **DOSAGE AND ADMINISTRATION, Dosing Considerations, Table 15**).

Hyperglycaemia: Hyperglycaemia has been reported in patients taking AFINITOR. Monitoring of fasting serum glucose is recommended prior to the start of AFINITOR or AFINITOR DISPERZ therapy and periodically thereafter (see **Monitoring and Laboratory Tests** below). More frequent monitoring is recommended when AFINITOR or AFINITOR DISPERZ is co-administered with other drugs that may induce hyperglycaemia. Optimal glycaemic control should be achieved before starting a patient on AFINITOR or AFINITOR DISPERZ. New onset

type 2 diabetes has occurred with AFINITOR treatment (see **ADVERSE REACTIONS**).

Gastrointestinal

Stomatitis, including mouth ulceration, is a common adverse event in patients treated with AFINITOR. Across the clinical trial experience, 44% to 86% of the patients receiving AFINITOR experienced stomatitis (see **ADVERSE REACTIONS**). Stomatitis mostly occurs within the first 8 weeks of treatment.

For mouth ulcers and stomatitis, topical treatments are recommended, but alcohol-, hydrogen peroxide-, iodine- or thyme-containing mouthwashes should be avoided as they may exacerbate the condition. Antifungal agents should not be used unless oral fungal infection has been diagnosed (see **DOSAGE AND ADMINISTRATION, Table 15** and **DRUG INTERACTIONS**).

A single arm study suggested that an alcohol-free corticosteroid oral solution, administered as a mouthwash during the initial 8 weeks of treatment with AFINITOR plus exemestane, may decrease the incidence and severity of stomatitis in postmenopausal breast cancer patients.

Haematologic

Decreased haemoglobin, lymphocytes, neutrophils and platelets have been reported in patients taking AFINITOR (see **ADVERSE REACTIONS**). Monitoring of complete blood count is recommended prior to the start of AFINITOR or AFINITOR DISPERZ therapy and periodically thereafter.

Haemorrhage

Clinical trials in patients with advanced cancers treated with AFINITOR have reported all grades of haemorrhage. In the RCC trial, gastrointestinal (GI) haemorrhage, retinal haemorrhage, vaginal haemorrhage, pulmonary alveolar haemorrhage, melaena and haematuria were reported as adverse events. In the hormone receptor-positive, HER2-negative advanced breast cancer trial, a single case of tumour haemorrhage was reported as a fatal adverse drug reaction. Post-marketing surveillance reported GI, tumour, pulmonary and cerebral haemorrhage as adverse events. Some cases were fatal (GI haemorrhage and cerebral haemorrhage). In the renal angiomyolipoma with TSC trial, low grade epistaxis, vaginal haemorrhage and menorrhagia were reported (see **ADVERSE REACTIONS**).

Caution is advised in patients taking AFINITOR or AFINITOR DISPERZ during concomitant use with active substances known to affect platelet function or that can increase the risk of haemorrhage and in patients with a history of bleeding disorders. Be vigilant for signs and symptoms of bleeding throughout the treatment period, especially if risk factors for haemorrhage are combined.

Immune

Hypersensitivity reactions: Hypersensitivity reactions manifested by symptoms including, but not limited to, anaphylaxis, dyspnoea, flushing, chest pain or angioedema (e.g. swelling of the airways or tongue, with or without respiratory impairment) have been observed with everolimus (see **CONTRAINDICATIONS**). Patients taking concomitant ACE inhibitor therapy may be at increased risk for angioedema (e.g. swelling of the airways or tongue, with or without respiratory impairment).

Infections: Everolimus has immunosuppressive properties and may predispose patients to bacterial, fungal, viral or protozoal infections, including infections with opportunistic pathogens (see **ADVERSE REACTIONS**). Localised and systemic infections, including pneumonia, other bacterial infections and invasive fungal infections, such as aspergillosis, candidiasis, or pneumocystis jirovecii pneumonia (PJP) and viral infections including reactivation of hepatitis B virus have been described in patients taking AFINITOR. Some of these infections have been severe (e.g. leading to sepsis [including septic shock], respiratory or hepatic failure) and occasionally have had a fatal outcome in adult and paediatric patients (see **WARNINGS AND PRECAUTIONS, Special Populations, Paediatrics**).

Physicians and patients should be aware of the increased risk of infection with AFINITOR or AFINITOR DISPERZ. Pre-existing infections should be treated and fully resolved prior to starting treatment with AFINITOR or AFINITOR DISPERZ. Be vigilant for signs and symptoms of infection; if a diagnosis of infection is made, institute appropriate treatment promptly and consider interruption or discontinuation of AFINITOR or AFINITOR DISPERZ.

If a diagnosis of invasive systemic fungal infection is made, discontinue AFINITOR or AFINITOR DISPERZ and treat with appropriate antifungal therapy (see **DOSAGE AND ADMINISTRATION**).

Cases of pneumocystis jirovecii pneumonia (PJP), some with fatal outcome, have been reported in patients who received everolimus. PJP may be associated with concomitant use of corticosteroids or other immunosuppressive agents. Prophylaxis for PJP should be considered when concomitant use of corticosteroids or other immunosuppressive agents are required.

Vaccinations: The use of live vaccines and close contact with those who have received live vaccines should be avoided during treatment with AFINITOR or AFINITOR DISPERZ (see **DRUG INTERACTIONS**). For paediatric patients with SEGA and/or seizures associated with TSC who do not require immediate treatment, complete the recommended childhood series of live vaccinations prior to the start of therapy according to local treatment guidelines (e.g. updated Canadian Immunization Guide).

Musculoskeletal and Connective Tissue Disorders

Rhabdomyolysis: There have been unconfirmed reports of rhabdomyolysis presenting as myalgia, muscle pain and weakness with significantly elevated creatine kinase in patients treated with AFINITOR. During AFINITOR or AFINITOR DISPERZ therapy, patients should be monitored for the possible development of rhabdomyolysis especially if they are prescribed a

concomitant statin. Patients on treatment with AFINITOR or AFINITOR DISPERZ should be advised to report promptly symptoms including muscle pain, weakness, or dark urine. If rhabdomyolysis is diagnosed, institute treatment promptly and consider interruption or discontinuation of AFINITOR or AFINITOR DISPERZ (see **DRUG INTERACTIONS**, **Drug-Drug Interactions**).

In a clinical trial of 118 patients with renal angiomyolipoma associated with TSC, one patient (<1%) receiving AFINITOR reported an adverse event of rhabdomyolysis.

Peri-operative Considerations

Impaired wound healing is a class effect of rapamycin derivatives, including everolimus. Caution should therefore be exercised with the use of AFINITOR or AFINITOR DISPERZ in the peri-surgical period.

Renal

Elevations of serum creatinine, usually mild, and proteinuria have been reported in patients taking AFINITOR (see **ADVERSE REACTIONS**). Monitoring of renal function, including measurement of blood urea nitrogen (BUN), urinary protein, or serum creatinine, is recommended prior to the start of AFINITOR or AFINITOR DISPERZ therapy and periodically thereafter. Renal function of patients should be monitored particularly where patients have additional risk factors that may further impair renal function (see also **Monitoring and Laboratory Tests** below).

Cases of renal failure (including acute renal failure), some with a fatal outcome, have been observed in patients treated with AFINITOR (see **ADVERSE REACTIONS**).

Respiratory

Non-infectious pneumonitis: Non-infectious pneumonitis is a class effect of rapamycin derivatives, including AFINITOR and AFINITOR DISPERZ. Cases of non-infectious pneumonitis (including interstitial lung disease) were reported in up to 19% of patients treated with AFINITOR (see **ADVERSE REACTIONS**). Some of these have been severe and on rare occasions, a fatal outcome was observed.

A diagnosis of non-infectious pneumonitis should be considered in patients presenting with non-specific respiratory signs and symptoms such as hypoxia, pleural effusion, cough or dyspnoea, and in whom infectious, neoplastic and other non-medicinal causes have been excluded by means of appropriate investigations. Opportunistic infections such as pneumocystis jirovecii pneumonia (PJP) should be ruled out in the differential diagnosis of non-infectious pneumonitis (see **Immune, Infections**). Patients should be advised to report promptly any new or worsening respiratory symptoms.

Patients who develop radiological changes suggestive of non-infectious pneumonitis and have few or no symptoms may continue AFINITOR or AFINITOR DISPERZ therapy without dose alteration.

If symptoms are moderate (Grade 2), consideration should be given to interruption of therapy until symptoms improve. The use of corticosteroids may be indicated. AFINITOR or AFINITOR DISPERZ may be reintroduced at a daily dose approximately 50% lower than the dose previously administered (see **DOSAGE AND ADMINISTRATION, Table 15**).

For cases of Grade 3 non-infectious pneumonitis, interrupt AFINITOR or AFINITOR DISPERZ until, resolution to less than or equal to Grade 1. AFINITOR or AFINITOR DISPERZ may be reintroduced at a daily dose approximately 50% lower than the dose previously administered, depending on the individual clinical circumstances. If toxicity recurs at Grade 3, consider discontinuation of AFINITOR or AFINITOR DISPERZ. For cases of Grade 4 non-infectious pneumonitis, AFINITOR or AFINITOR DISPERZ therapy should be discontinued. Corticosteroids may be indicated until clinical symptoms resolve. For patients who require use of corticosteroids for treatment of non-infectious pneumonitis, prophylaxis for pneumocystis jirovecii pneumonia (PJP) should be considered. The development of pneumonitis has also been reported at a reduced dose (see **DOSAGE AND ADMINISTRATION, Table 15**).

Sporadic lymphangi leiomyomatosis (LAM)

The safety and effectiveness of AFINITOR in the treatment of patients with renal angiomyolipoma associated with sporadic LAM has not been established.

Vascular

Deep vein thrombosis (DVT) and pulmonary embolism (PE) events have been reported with AFINITOR use in clinical trials (see **ADVERSE REACTIONS**).

Special Populations

Pregnant women: Foetal harm may occur when administered to pregnant women. Apprise women of potential harm to the foetus. Animal studies have shown post-implantation loss in rats and rabbits as well as foetal toxicity at below clinical exposures (see **TOXICOLOGY**).

Nursing women: It is not known whether everolimus is excreted in breast milk. However, in animal studies everolimus and/or its metabolites readily passed into the milk of lactating rats. Women taking AFINITOR or AFINITOR DISPERZ should therefore not breastfeed during treatment and for 2 weeks after the last dose.

Women of childbearing potential: Women of childbearing potential, including pre-pubertal women, should be advised to use a highly effective method of contraception while receiving AFINITOR or AFINITOR DISPERZ, and for up to 8 weeks after ending treatment.

If amenorrhoea develops in a woman of childbearing potential who is receiving AFINITOR or AFINITOR DISPERZ, use of a highly effective method of contraception should continue.

In the renal angiomyolipoma associated with TSC clinical trial, secondary amenorrhoea has been reported in 15% of females receiving everolimus and in 4% of females receiving placebo. In the SEGA associated with TSC trial, amenorrhea occurred in 17% of females receiving everolimus and in none of the females receiving placebo. The mechanism is unknown. Early referral of patients with menstrual irregularities to endocrine specialists is recommended (see **ADVERSE REACTIONS**).

Fertility: Both female and male fertility may be compromised by treatment with AFINITOR or AFINITOR DISPERZ. Secondary amenorrhoea and associated luteinizing hormone (LH)/follicle stimulating hormone (FSH) imbalance have been observed in female patients receiving AFINITOR. Blood levels of FSH and LH increased, blood levels of testosterone decreased, and azoospermia have been observed in male patients receiving AFINITOR. A reduction in male fertility has also been demonstrated in animal studies (see **TOXICOLOGY**).

Geriatrics (≥ 65 years of age): In the randomized hormone receptor-positive, HER2-negative advanced breast cancer study, the incidence of deaths due to any cause within 28 days of the last AFINITOR dose was 3.7% overall; 6.3% in patients ≥ 65 years of age compared to 2.1% in patients < 65 years of age. Adverse reactions leading to permanent treatment discontinuation occurred in 33% of patients ≥ 65 years of age compared to 17% in patients < 65 years of age. Careful monitoring and appropriate dose adjustments for adverse reactions are recommended (see **DOSAGE AND ADMINISTRATION**).

Other reported clinical experience has not identified differences in response between the elderly and younger patients (see **ACTION AND CLINICAL PHARMACOLOGY, Special Populations and Conditions, Geriatrics**).

Paediatrics (< 18 years of age): AFINITOR and AFINITOR DISPERZ is not recommended for use in paediatric cancer patients.

AFINITOR and AFINITOR DISPERZ have not been studied in paediatric patients with SEGA < 1 year of age and are not recommended for use in this age group. There are limited efficacy and safety data in patients 1 to 3 years of age with AFINITOR in patients with SEGA.

AFINITOR DISPERZ has not been studied in paediatric patients < 2 years of age with seizures associated with TSC and is not recommended for use in this age group.

The optimal duration of AFINITOR or AFINITOR DISPERZ therapy for patients with SEGA is not known; however, SEGA re-growth has been reported to occur once therapy is discontinued (see **DOSAGE AND ADMINISTRATION, SEGA volume monitoring for patients treated with AFINITOR and AFINITOR DISPERZ** and **CLINICAL TRIALS, SEGA associated with Tuberous Sclerosis Complex**).

Non-clinical data suggest that there is a risk of delayed developmental landmarks and delayed reproductive development in patients taking everolimus. In juvenile rat toxicity studies, dose-related delayed attainment of developmental landmarks including delayed eye-opening, delayed reproductive development in males and females, and increased latency time during the learning and memory phases were observed at doses as low as 0.15 mg/kg/day (see **TOXICOLOGY**).

Although a conclusive determination cannot be made due to the lack of a comparator arm in the open label follow-up periods of two phase III studies and a phase II study, AFINITOR did not appear to adversely impact growth and pubertal development in the 409 paediatric patients treated with AFINITOR in clinical trials with an estimated exposure of 944.20 patient treatment years (PTY).

The effect of AFINITOR on neurological development is unknown, AFINITOR has not been associated with adverse effects on neurological development in children. Body weight, longitudinal growth and pubertal development should be monitored at regular intervals (every 12 months) and neurological development should be monitored according to TSC guidelines in paediatric patients. Therapy should be individualized for the patient and clinical situation.

AFINITOR and AFINITOR DISPERZ are not recommended for use in paediatric patients with renal angiomyolipoma associated with TSC in the absence of AFINITOR or AFINITOR DISPERZ treatment for SEGA.

The overall type, frequency and severity of adverse events across the age groups were similar, with the exception of infections, which occurred at a higher frequency and severity in patients <6 years of age. A total of 46 out of 137 patients (34%) <6 years had Grade 3/4 infections, compared to 49 out of 272 patients (18%) 6 to <18 years and 24 out of 203 patients (12%) ≥18 years. In the clinical trial conducted in patients with seizures associated with TSC, two fatal cases due to infection were reported in 409 patients <18 years receiving everolimus.

Hepatic impairment: Exposure to everolimus is increased in patients with hepatic impairment. AFINITOR is recommended at a reduced dose in patients with hormone receptor-positive, HER2-negative advanced breast cancer, advanced NET, metastatic RCC or renal angiomyolipoma associated with TSC who have severe hepatic impairment only if the potential benefits outweigh the risks. For patients with mild (Child-Pugh A) or moderate (Child-Pugh B) hepatic impairment, AFINITOR is recommended at a reduced dose (see **DOSAGE AND ADMINISTRATION, Hormone Receptor-Positive, HER2-Negative Advanced Breast Cancer, Advanced NET, Metastatic RCC and Renal Angiomyolipoma associated with TSC** and **ACTION AND CLINICAL PHARMACOLOGY, Special Populations and Conditions, Hepatic Impairment**).

No data are available in a paediatric population with hepatic impairment. Everolimus clearance, normalised to body-surface area, may be higher in younger patients than in adults and therefore the available adult data in hepatic impairment cannot be used to predict paediatric dosing (see **ACTION AND CLINICAL PHARMACOLOGY, Special Populations and Conditions, Paediatrics**). AFINITOR and AFINITOR DISPERZ are not recommended for use in patients < 18 years of age with SEGA and concomitant hepatic impairment (Child-Pugh A, B or C). AFINITOR or AFINITOR DISPERZ are not recommended for use in patients ≥ 18 years of age with SEGA and severe hepatic impairment (Child-Pugh C). For patients ≥ 18 years of age with SEGA who have mild (Child-Pugh A) or moderate (Child-Pugh B) hepatic impairment, AFINITOR or AFINITOR DISPERZ are recommended at a reduced dose. AFINITOR DISPERZ is not recommended for use in patients < 18 years of age with seizures associated with TSC and concomitant hepatic impairment (Child-Pugh A, B or C). AFINITOR DISPERZ is not

recommended for use in patients ≥ 18 years of age with seizures associated with TSC who have severe hepatic impairment (Child-Pugh C). The AFINITOR DISPERZ dose should be reduced in patients ≥ 18 years of age with seizures associated with TSC who have mild (Child-Pugh A) or moderate (Child-Pugh B) hepatic impairment, (see **DOSAGE AND ADMINISTRATION** and **ACTION AND CLINICAL PHARMACOLOGY, Special Populations and Conditions, Hepatic Impairment**).

Monitoring and Laboratory Tests

Evaluation of CBC and serum chemistries (including blood glucose, lipids, liver function tests, creatinine, BUN, electrolytes, magnesium, calcium and phosphate) and urinary protein should be performed at the beginning of treatment with AFINITOR or AFINITOR DISPERZ and periodically thereafter.

Body weight, longitudinal growth and pubertal development should be monitored at regular intervals (every 12 months) and neurological development should be monitored according to TSC guidelines in paediatric patients (see **Special Populations, Paediatrics**).

ADVERSE REACTIONS

Adverse Events in Hormone Receptor-Positive, HER2-Negative Advanced Breast Cancer

Adverse Reaction Overview

The data described below reflect exposure to AFINITOR (10 mg/day) in combination with exemestane (25 mg/day) (n=482) and placebo in combination with exemestane (25 mg/day) (n=238) in a randomized, placebo-controlled phase III study (BOLERO-2) for the treatment of postmenopausal women with oestrogen receptor-positive, HER 2-neu/non-amplified locally advanced breast cancer² or metastatic breast cancer. The median age of patients was 61 years (range 28 - 93) and 75% were Caucasian. Safety results are based on a median follow-up of approximately 13 months. As of the data cut-off date of the updated analysis, the median duration of treatment with AFINITOR was 23.9 weeks (range: 1 to 100) with a median dose intensity of 8.7 mg/day; the median duration of placebo therapy was 13.4 weeks (range: 1 to 79).

The most common treatment-emergent adverse events irrespective of causality (incidence $\geq 30\%$) were stomatitis, infections, rash, fatigue, diarrhoea and decreased appetite. Grade 3-4 events were observed more frequently among patients receiving AFINITOR plus exemestane than patients receiving placebo plus exemestane [grade 3 (40.9% vs. 22.3%, respectively) and grade 4 (8.7% vs. 5.0%, respectively)]. The most common grade 3-4 adverse events (incidence $\geq 3\%$) were stomatitis, infections, fatigue, dyspnoea and pneumonitis. Specific grade 3 or grade 4 infections were: pneumonia (1.2%), sepsis (0.3%), gastroenteritis (0.6%), and primary atypical pneumonia (0.4%). The most common laboratory abnormalities (incidence $\geq 50\%$) were hypercholesterolaemia, hyperglycaemia, increased AST, anaemia, leukopenia,

² N=2 patients (0.4%) in the AFINITOR plus exemestane arm only

thrombocytopenia, lymphopenia, increased ALT and hypertriglyceridaemia. The most common grade 3-4 laboratory abnormalities (incidence $\geq 3\%$) were lymphopenia, anaemia, hyperglycaemia, increased gamma-glutamyltransferase, decreased potassium, increased AST, increased ALT and thrombocytopenia. Fatal adverse reactions occurred in 7/482 (1.5%) of patients who received AFINITOR plus exemestane, with one death each due to pneumonia, sepsis, staphylococcal sepsis, tumour haemorrhage, ischemic stroke, completed suicide and renal failure. One death (0.4%) due to pneumonia occurred among 238 patients on the placebo plus exemestane arm.

The rates of treatment-emergent adverse events resulting in permanent discontinuation were 24% and 5% for the AFINITOR plus exemestane and placebo plus exemestane treatment groups, respectively. The most commonly reported AEs leading to discontinuation in the AFINITOR plus exemestane arm were: pneumonitis (4.4% of patients), stomatitis (2.5%), dyspnoea (1.9%), fatigue (1.9%), decreased appetite (1.7%), anaemia (1.7%) and rash (1.5%). The incidence of dose adjustments was 64% among patients receiving AFINITOR in the AFINITOR plus exemestane arm and 21% among patients receiving placebo in the placebo plus exemestane arm. Adverse events necessitating dose adjustments (interruptions or reductions) were more frequent among patients in the AFINITOR plus exemestane arm than in the placebo plus exemestane arm (60% versus 12%, respectively). The most commonly reported AEs that necessitated dose interruption or reduction for the AFINITOR plus exemestane arm were stomatitis (23.7% of patients), pneumonitis (7.3%) and thrombocytopenia (5.2%).

Clinical Trial Adverse Reactions

Table 1 compares the incidence of treatment-emergent adverse events reported with an incidence of $\geq 10\%$ for patients receiving AFINITOR 10 mg daily versus placebo.

Treatment-emergent adverse events in Table 1 are listed according to MedDRA system organ class. Within each system organ class, the adverse events are ranked by frequency, with the most frequent events first.

Table 1 Adverse events, irrespective of causality, reported in at least 10% of patients and at a higher rate in the AFINITOR arm than in the placebo arm (Hormone Receptor-Positive, HER2- Negative Advanced Breast Cancer)

	AFINITOR + exemestane N=482			Placebo + exemestane N=238		
	All grades	Grade 3	Grade 4	All grades	Grade 3	Grade 4
	%	%	%	%	%	%
Any Adverse Event	100	41	9	90	22	5
Gastrointestinal Disorders						
Stomatitis ^a	67	8	0	11	0.8	0
Diarrhoea	33	2	0.2	18	0.8	0
Nausea	29	0.2	0.2	28	1	0
Vomiting	17	0.8	0.2	12	0.8	0

	AFINITOR + exemestane N=482			Placebo + exemestane N=238		
	All grades	Grade 3	Grade 4	All grades	Grade 3	Grade 4
	%	%	%	%	%	%
Constipation	14	0.4	0	13	0.4	0
Dry mouth	11	0	0	7	0	0
General Disorders and Administration Site Conditions						
Fatigue	36	4	0.4	27	1	0
Oedema peripheral	19	1	0	6	0.4	0
Pyrexia	15	0.2	0	7	0.4	0
Asthenia	13	2	0.2	4	0	0
Infections and Infestations						
Infections ^b	50	4	1	25	2	0
Investigations						
Weight decreased	25	1	0	6	0	0
Metabolism and Nutrition Disorders						
Decreased appetite	30	1	0	12	0.4	0
Hyperglycaemia	14	5	0.4	2	0.4	0
Musculoskeletal and Connective Tissue Disorders						
Arthralgia	20	0.8	0	17	0	0
Back pain	14	0.2	0	10	0.8	0
Pain in extremity	9	0.4	0	11	2	0
Nervous System Disorders						
Dysgeusia	22	0.2	0	6	0	0
Headache	21	0.4	0	14	0	0
Psychiatric disorders						
Insomnia	13	0.2	0	8	0	0
Respiratory, Thoracic and Mediastinal Disorders						
Cough	24	0.6	0	12	0	0
Dyspnoea	21	4	0.2	11	0.8	0.4
Epistaxis	17	0	0	1	0	0
Pneumonitis ^c	19	4	0.2	0.4	0	0
Skin and Subcutaneous Tissue Disorders						
Rash	39	1	0	6	0	0
Pruritus	13	0.2	0	5	0	0
Alopecia	10	0	0	5	0	0
Vascular Disorders						
Hot flush	6	0	0	14	0	0

CTCAE Version 3.0

^a Includes stomatitis, mouth ulceration, aphthous stomatitis, glossodynia, gingival pain, glossitis and lip ulceration

	AFINITOR + exemestane N=482			Placebo + exemestane N=238		
	All grades	Grade 3	Grade 4	All grades	Grade 3	Grade 4
	%	%	%	%	%	%

^b Includes all preferred terms within the ‘infections and infestations’ system organ class, the most common being nasopharyngitis (10%), urinary tract infection (10%), upper respiratory tract infection (5%), pneumonia (4%), bronchitis (4%), cystitis (3%), sinusitis (3%), and also including candidiasis (<1%), sepsis (<1%) and hepatitis C (<1%).

^c Includes pneumonitis, interstitial lung disease, lung infiltration and pulmonary fibrosis

Other treatment-emergent adverse reactions occurring more frequently with AFINITOR than with placebo, but with an incidence of < 10% and considered clinically relevant include:

Cardiac disorders: Tachycardia (3%)

Ear and labyrinth disorders: Deafness (0.8%)

Gastrointestinal disorders: Abdominal pain (5%), dysphagia (2%), gingivitis (2%)

Metabolism and nutrition disorders: Diabetes mellitus (1%), dehydration (3%)

Nervous system disorders: Ageusia (1%)

Renal and urinary disorders: Renal failure (1%), renal failure acute (0.8%), renal impairment (1%)

Respiratory, thoracic and mediastinal disorders: Pleural effusion (4%), pulmonary embolism (2%), haemoptysis (1%)

Skin and subcutaneous tissue disorders: Nail disorder (8%), erythema (4%), acne (3%), hand-foot syndrome (reported as palmar-plantar erythrodysesthesia syndrome) (0.6%), angioedema (0.2%)

Vascular disorders: Hypertension (8%), lymphoedema (6%), muscle haemorrhage (0.8%), rectal haemorrhage (0.8%), haemorrhoidal haemorrhage (0.6%), intra-abdominal haematoma (0.6%), deep vein thrombosis (1%)

Abnormal Haematologic and Clinical Chemistry Findings

Clinically relevant laboratory abnormalities are presented in Table 2.

Table 2 Clinically relevant laboratory abnormalities reported in > 10% of patients and at a higher rate in the AFINITOR arm than in the placebo arm (Hormone Receptor-Positive, HER2- Negative Advanced Breast Cancer)

Laboratory parameter	AFINITOR + exemestane N=482			Placebo + exemestane N=238		
	All grades	Grade 3	Grade 4	All grades	Grade 3	Grade 4
	%	%	%	%	%	%
Haematology^a						
Haemoglobin decreased	68	6	0.6	40	0.8	0.4
WBC decreased	58	1	0	28	0	0.8
Platelets decreased	54	3	0.2	5	0	0.4
Lymphocytes decreased	54	11	0.6	37	5	0.8
Neutrophils decreased	31	2	0	11	0.8	0.8
Clinical chemistry						
Glucose increased	69	9	0.4	44	0.8	0.4
Cholesterol increased	70	0.6	0.2	38	0.8	0.8
Aspartate transaminase (AST) increased	69	4	0.2	45	3	0.4
Gamma-glutamyltransferase increased	59	10	3	54	13	3
Alanine transaminase (ALT) increased	51	4	0.2	29	5	0
Triglycerides increased	50	0.8	0	26	0	0
Albumin decreased	33	0.8	0	16	0.8	0
Potassium decreased	29	4	0.2	7	1	0
Creatinine increased	24	2	0.2	13	0	0

CTCAE Version 3.0

^a Reflects corresponding adverse drug reaction reports of anaemia, leukopenia, lymphopenia, neutropenia and thrombocytopenia (collectively as pancytopenia), which occurred at lower frequency

Adverse Events in Advanced Pancreatic Neuroendocrine Tumours

Adverse Reaction Overview

In a randomised, controlled trial of AFINITOR (n=204) versus placebo (n=203) in patients with advanced pancreatic neuroendocrine tumours (PNET) the median age of patients was 58 years (range 23-87 years), 79% were Caucasian and 55% were male. The median duration of blinded study treatment was 37 weeks (range 1-130) for patients receiving AFINITOR and 16 weeks (range 0-146) for those receiving placebo. Patients on the placebo arm could cross over to open-label AFINITOR upon disease progression.

The most common adverse reactions (incidence $\geq 30\%$) were stomatitis, rash, diarrhoea, fatigue, oedema, abdominal pain, nausea, fever and headache. The most common grade 3/4 adverse reactions (incidence $\geq 5\%$) were stomatitis and diarrhoea. The most common laboratory abnormalities (incidence $\geq 50\%$) were decreased haemoglobin, hyperglycaemia, alkaline

phosphatase increased, hypercholesterolaemia, bicarbonate decreased and increased aspartate transaminase (AST). The most common grade 3/4 laboratory abnormalities (incidence $\geq 3\%$) were hyperglycaemia, lymphopenia, decreased haemoglobin, hypophosphataemia, increased alkaline phosphatase, neutropenia, increased aspartate transaminase (AST), potassium decreased and thrombocytopenia.

On-treatment deaths due to infections (1%), renal failure (0.5%), cardiac arrest (0.5%), death (0.5%), hepatic failure (0.5%) and acute respiratory distress (0.5%) were observed in the AFINITOR arm, but none in placebo arm. There was 1 on-treatment death due to pulmonary embolism (0.5%) in the placebo arm. The rates of treatment-emergent adverse events (irrespective of causality) resulting in permanent discontinuation were 20.1% and 5.9% for the AFINITOR and placebo treatment groups, respectively.

The most common adverse reactions (irrespective of causality) leading to treatment discontinuation were pneumonitis, infections and pyrexia. Infections, stomatitis, pneumonitis, thrombocytopenia and pyrexia were the most common reasons for treatment delay or dose reduction. The most common medical interventions required during AFINITOR treatment were for infections, stomatitis, rash, diarrhoea and peripheral oedema.

Clinical Trial Adverse Reactions

Table 3 compares the incidence of treatment-emergent adverse reactions reported with an incidence of $\geq 10\%$ for patients receiving AFINITOR 10 mg daily versus placebo. Within each MedDRA system organ class, the adverse reactions are presented in order of decreasing frequency.

Table 3 Adverse reactions reported in at least 10% of patients and at a higher rate in the AFINITOR arm than in the placebo arm (PNET)

	AFINITOR N=204			Placebo N=203		
	All grades	Grade 3	Grade 4	All grades	Grade 3	Grade 4
	%	%	%	%	%	%
Any adverse reaction	100	49	13	98	32	8
Gastrointestinal disorders						
Stomatitis ^a	70	7	0	20	0	0
Diarrhoea ^b	50	5	0.5	25	3	0
Abdominal pain	36	4	0	32	6	1
Nausea	32	2	0	33	2	0
Vomiting	29	1	0	21	2	0
Constipation	14	0	0	13	0.5	0
Dry mouth	11	0	0	4	0	0
General disorders and administration site conditions						
Fatigue/malaise	45	3	0.5	27	2	0.5

	AFINITOR N=204			Placebo N=203		
	All grades	Grade 3	Grade 4	All grades	Grade 3	Grade 4
	%	%	%	%	%	%
Oedema (general and peripheral)	39	1	0.5	12	1	0
Fever	31	0.5	0.5	13	0.5	0
Asthenia	19	3	0	20	3	0
Infections and infestations						
Nasopharyngitis/rhinitis/URI	25	0	0	13	0	0
Urinary tract infection	16	0	0	6	0.5	0
Investigations						
Weight decreased	28	0.5	0	11	0	0
Metabolism and nutrition disorders						
Decreased appetite	30	1	0	18	1	0
Diabetes mellitus	10	2	0	0.5	0	0
Musculoskeletal and connective tissue disorders						
Arthralgia	15	1	0.5	7	0.5	0
Back pain	15	1	0	11	1	0
Pain in extremity	14	0.5	0	6	1	0
Muscle spasms	10	0	0	4	0	0
Nervous system disorders						
Headache/migraine	30	0.5	0	15	1	0
Dysgeusia	19	0	0	5	0	0
Dizziness	12	0.5	0	7	0	0
Psychiatric disorders						
Insomnia	14	0	0	8	0	0
Respiratory, thoracic and mediastinal disorders						
Cough/productive cough	25	0.5	0	13	0	0
Epistaxis	22	0	0	1	0	0
Dyspnoea/dyspnoea exertional	20	2	0.5	7	0.5	0
Pneumonitis ^c	17	3	0.5	0	0	0
Oropharyngeal pain	11	0	0	6	0	0
Skin and subcutaneous disorders						
Rash	59	0.5	0	19	0	0
Nail disorders	22	0.5	0	2	0	0
Pruritus/pruritus generalized	21	0	0	13	0	0
Dry skin/xeroderma	13	0	0	6	0	0
Vascular disorders						
Hypertension	13	1	0	6	1	0

	AFINITOR N=204			Placebo N=203		
	All grades	Grade 3	Grade 4	All grades	Grade 3	Grade 4
	%	%	%	%	%	%
Median duration of treatment (wks)	37			16		

CTCAE Version 3.0

^a Includes stomatitis, aphthous stomatitis, gingival pain/swelling/ulceration, glossitis, glossodynia, lip ulceration, mouth ulceration, tongue ulceration and mucosal inflammation.

^b Includes diarrhoea, enteritis, enterocolitis, colitis, defecation urgency and steatorrhoea.

^c Includes pneumonitis, interstitial lung disease, pulmonary fibrosis and restrictive pulmonary disease.

Other treatment-emergent adverse reactions occurring more frequently with AFINITOR than with placebo, but with an incidence of < 10% and considered clinically relevant include:

Respiratory, thoracic and mediastinal disorders: Pleural effusion (7%), pulmonary embolism (2%), pulmonary oedema (1%)

General disorders and administration site conditions: Chills (6%), chest pain (3%), generalised oedema (2%)

Psychiatric disorders: Depression (6%)

Skin and subcutaneous tissue disorders: Acne (6%), erythema (5%), hand-foot syndrome (reported as palmar-plantar erythrodysesthesia syndrome) (3%), angioedema (0.5%)

Gastrointestinal disorders: Dysphagia (3%), oral pain (3%), small intestinal obstruction (0.5%)

Cardiac disorders: Angina pectoris (2%), cardiac failure (1%)

Renal and urinary disorders: Proteinuria (4%), renal failure (2%)

Haematologic disorders: Pure red cell aplasia (0.5%)

Metabolism and nutrition disorders: Dehydration (6%)

Reproductive system and breast disorders: Menstruation irregular (3%)

Abnormal Haematological and Clinical Chemistry Findings

Clinically relevant laboratory abnormalities are presented in Table 4.

Table 4 Clinically relevant laboratory abnormalities reported in $\geq 10\%$ of patients and at a higher rate in the AFINITOR arm than in the placebo arm (PNET)

Laboratory parameter	AFINITOR N=204		Placebo N=203	
	All grades	Grade 3-4	All grades	Grade 3-4
	%	%	%	%
Haematology				
Haemoglobin decreased	86	15	63	1
Lymphocytes decreased	45	16	22	4
Platelets decreased	45	3	11	0
WBC decreased	43	2	13	0
Neutrophils decreased	30	4	17	2
Clinical chemistry				
Alkaline phosphatase increased	74	8	66	8
Glucose (fasting) increased	75	17	53	6
Cholesterol increased	66	0.5	22	0
Bicarbonate decreased	56	0	40	0
Aspartate transaminase (AST) increased	56	4	41	4
Alanine transaminase (ALT) increased	48	2	35	2
Phosphate decreased	40	10	14	3
Triglycerides increased	39	0	10	0
Calcium decreased	37	0.5	12	0
Potassium decreased	23	4	5	0
Creatinine increased	19	2	14	0
Sodium decreased	16	1	16	1
Albumin decreased	13	1	8	0
Bilirubin increased	10	1	14	2
Potassium increased	7	0	10	0.5

CTCAE Version 3.0

Adverse Events in Advanced Non-Functional Neuroendocrine Tumours of Gastrointestinal or Lung Origin

Adverse Reaction Overview

The data described below reflect exposure to AFINITOR (n=205) and placebo (n=97) in a randomized, controlled phase III study (RADIANT-4) in patients with advanced non-functional NET of GI or lung origin. The median duration of blinded study treatment was 40 weeks for patients receiving AFINITOR and 20 weeks for those receiving placebo.

Serious adverse events (SAEs) were reported more frequently in AFINITOR-treated group (42.1%) than in the placebo group (19.4%). While the incidence of specific individual SAEs was low for both treatment groups, the most commonly reported SAEs in AFINITOR group,

irrespective of causal relationship to the study drug, were abdominal pain (5.4%), pyrexia (4.5%), diarrhea (4.0%), anemia (3.0%), pneumonia (3.0%), small intestinal obstruction (3.0%), asthenia (2.5%), fatigue (2.5%), vomiting (2.5%), and pneumonitis (2.0%).

Deaths during double-blind treatment where an adverse event was the primary cause occurred in three patients on AFINITOR (1.5%) and two patients on placebo (2.0%). Causes of death due to an adverse event on the AFINITOR arm included one case of each of the following: cardiac failure, respiratory failure and septic shock. Causes of death on the placebo arm due to an adverse event included one case of lung infection and one case of dyspnea. The rates of treatment-emergent adverse events resulting in permanent discontinuation were 29% and 7% for the AFINITOR and placebo treatment groups, respectively. Dose delay or reduction was necessary in 70% of AFINITOR patients and 19% of placebo patients.

The most frequent adverse events (AEs) ($\geq 5\%$), irrespective of causality, requiring dose adjustment or interruption were anaemia, stomatitis, diarrhea, fatigue, oedema peripheral, pyrexia, pneumonitis. The most frequent AEs (irrespective of causality) leading to treatment discontinuation were stomatitis (3.0%), GGT increased (1.5%) and diarrhea (1.5%). Other AEs occurred in $\leq 1\%$ of patients each.

The most common ($\geq 10\%$) adverse events (irrespective of causality) requiring medical intervention during AFINITOR treatment were anemia, stomatitis, diarrhea, abdominal pain, nausea, pyrexia, oedema peripheral, urinary tract infection, pneumonitis, cough, rash and hypertension.

Table 5 compares the incidence of treatment-emergent adverse events reported with an incidence of $\geq 10\%$ for patients receiving AFINITOR 10 mg daily plus best supportive care versus placebo plus best supportive care. Within each MedDRA system organ class, the adverse reactions are presented in order of decreasing frequency.

Clinical Trial Adverse Reactions

Table 5 Adverse events reported in at least 10% of patients with advanced non-functional neuroendocrine tumours (NET) of gastrointestinal or lung origin and at a higher rate in the AFINITOR arm than in the placebo arm

	AFINITOR N=202			Placebo N=98		
	All grades	Grade 3	Grade 4	All grades	Grade 3	Grade 4
	%	%	%	%	%	%
Any adverse reaction	99	57	12	89	21	7
Blood and lymphatic system disorders						
Anemia	22	5	1	12	3	0
Gastrointestinal disorders						
Stomatitis ^a	63	9	0	22	0	0

Diarrhea	41	8	1	31	2	0
Nausea	26	3	1	17	1	0
Vomiting	15	4	0	12	2	0
General disorders and administration site conditions						
Edema peripheral	39	3	0	6	1	0
Fatigue	37	4	1	36	1	0
Asthenia	23	2	1	8	0	0
Pyrexia	23	1	1	8	0	0
Infections and infestations						
Infections ^b	58	8	3	29	1	1
Investigations						
Weight decreased	22	2	0	11	1	0
Metabolism and nutrition disorders						
Decreased appetite	22	1	0	17	1	0
Hyperglycemia	12	5	0	3	0	0
Musculoskeletal and connective tissue disorders						
Arthralgia	12	1	0	8	0	0
Nervous system disorders						
Dysgeusia	18	1	0	4	0	0
Psychiatric disorders						
Insomnia	10	0	0	7	1	0
Respiratory, thoracic and mediastinal disorders						
Cough	27	0	0	20	0	0
Dyspnea	20	3	0	11	1	1
Pneumonitis ^c	16	2	0	2	0	0
Epistaxis	13	1	0	3	0	0
Skin and subcutaneous disorders						
Rash	30	1	0	9	0	0
Pruritus	17	1	0	9	0	0
Vascular disorders						
Hypertension	12	4	0	8	3	0
Grading according to CTCAE Version 4.03						
^a Includes stomatitis, mouth ulceration, aphthous stomatitis, gingival pain, glossitis, tongue ulceration and mucosal inflammation.						
^b Urinary tract infection, nasopharyngitis, upper respiratory tract infection, lower respiratory tract infection (pneumonia, bronchitis), abscess, pyelonephritis, septic shock and viral myocarditis.						
^c Includes pneumonitis and interstitial lung disease.						

Other clinically relevant treatment-emergent adverse events with an incidence of < 10% in AFINITOR group but occurring more frequently than with placebo, include:

Blood and lymphatic system disorders: Thrombocytopenia (4%), neutropenia (3%)

Cardiac disorders: Cardiac failure (3%), cardiac failure congestive (1%), cardiac failure chronic (1%), left ventricular dysfunction (1%)

Eye disorders: Eyelid oedema (4%)

Gastrointestinal disorders: Small intestinal obstruction (3%), intestinal obstruction (2%), dysphagia (3%)

General disorders and administration site conditions: Impaired healing (1%)

Investigations: Alanine aminotransferase increased (5%), blood cholesterol increased (5%), gamma-glutamyltransferase increased (5%), aspartate aminotransferase increased (4%), blood creatinine increased (4%)

Metabolism and nutrition disorders: Hypokalaemia (10%), hypercholesterolaemia (6%), hypertriglyceridaemia (5%), hypophosphataemia (5%), diabetes mellitus (4%), type 2 diabetes mellitus (1%), hypocalcaemia (4%)

Musculoskeletal and connective tissue disorders: Pain in extremity (9%), myalgia (6%)

Nervous system disorders: Lethargy (4%), Paraesthesia (2%)

Renal and urinary disorders: Proteinuria (8%), renal failure (1%)

Respiratory, thoracic and mediastinal disorders: Pleural effusion (5%)

Skin and subcutaneous tissue disorders: Dermatitis acneiform (9%), dry skin (9%), nail disorder (6%), erythema (6%), acne (5%), palmar-plantar erythrodysesthesia syndrome (4%)

Vascular disorders: Deep vein thrombosis (1%), phlebitis (1%)

Abnormal Haematological and Clinical Chemistry Findings

Clinically relevant laboratory abnormalities are presented in Table 6.

Table 6 Clinically relevant laboratory abnormalities reported in $\geq 10\%$ of patients with advanced non-functional neuroendocrine tumours (NET) of gastrointestinal or lung origin and at a higher rate in the AFINITOR arm than in the placebo arm

	AFINITOR N=202			Placebo N=98		
	All grades %	Grade 3 %	Grade 4 %	All grades %	Grade 3 %	Grade 4 %
Hematology						
Hemoglobin decreased	81	5	0	41	2	0
Lymphocytes decreased	66	15	2	32	2	0
White blood cell count decreased	49	2	0	17	0	0
Platelets decreased	33	2	1	11	0	0
Neutrophils decreased	32	2	0	15	3	0
Clinical chemistry						
Creatinine increased	82	2	1	82	1	1
Cholesterol increased	71	0	0	37	0	0
Aspartate transaminase (AST) increased	57	1	1	34	2	0
Glucose (fasting) increased	55	6	0	36	1	0
Alanine transaminase (ALT) increased	46	5	1	39	1	0
Phosphate decreased	43	4	0	15	2	0
Triglycerides increased	30	3	1	8	1	0
Potassium decreased	27	4	2	12	3	0
Albumin decreased	18	0	0	8	0	0

Grading according to CTCAE Version 4.03

Adverse Events in Metastatic RCC

Adverse Reaction Overview

The data described below reflect exposure to AFINITOR (n=274) and placebo (n=137) in a randomised phase III study for the treatment of metastatic renal cell carcinoma. In total, 165 patients were exposed to AFINITOR 10 mg/day for ≥ 4 months. The median age of patients was 61 years (range 27 to 85 years), 90% were Caucasian and 78% were males. The median duration of blinded study treatment was 141 days (range 19 to 451) for patients receiving AFINITOR and 60 days (range 21 to 295) for those receiving placebo.

The most common treatment-emergent adverse events irrespective of causality (incidence $\geq 30\%$) were stomatitis, anaemia, infections, asthenia, fatigue, cough and diarrhoea. The most common grade 3-4 adverse events (incidence $\geq 3\%$) were anaemia, infections, dyspnoea, hyperglycaemia, stomatitis, fatigue, dehydration, pneumonitis, abdominal pain, asthenia and hypercholesterolaemia.

The rates of treatment-emergent adverse events resulting in permanent discontinuation were 14% and 3% for the AFINITOR and placebo treatment groups, respectively. Most treatment-emergent adverse events were grade 1 or 2 in severity.

Clinical Trial Adverse Reactions

Table 7 compares the incidence of treatment-emergent adverse events reported with an incidence of $\geq 10\%$ for patients receiving AFINITOR 10 mg/day versus placebo.

Treatment-emergent adverse events in Table 7 are listed according to MedDRA system organ class. Within each system organ class, the adverse events are ranked by frequency, with the most frequent events first.

Table 7 Adverse events, irrespective of causality, reported in at least 10% of patients and at a higher rate in the AFINITOR arm than in the placebo arm (mRCC)

	AFINITOR 10 mg/day N=274			Placebo N=137		
	All grades	Grade 3	Grade 4	All grades	Grade 3	Grade 4
	%	%	%	%	%	%
Any Adverse Event	97	52	13	93	23	5
Gastrointestinal Disorders						
Stomatitis ^a	44	4	<1	8	0	0
Diarrhoea	30	1	0	7	0	0
Nausea	26	1	0	19	0	0
Vomiting	20	2	0	12	0	0
Blood and Lymphatic System Disorders						
Anaemia	38	9	<1	15	4	<1
Infections and Infestations^b	37	7	3	18	1	0
General Disorders and Administration Site Conditions						
Asthenia	33	3	<1	23	4	0
Fatigue	31	5	0	27	3	<1
Oedema peripheral	25	<1	0	8	<1	0
Pyrexia	20	<1	0	9	0	0
Mucosal inflammation	19	1	0	1	0	0
Respiratory, Thoracic and Mediastinal Disorders						
Cough	30	<1	0	16	0	0
Dyspnoea	24	6	1	15	3	0
Epistaxis	18	0	0	0	0	0
Pneumonitis ^c	14	4	0	0	0	0
Skin and Subcutaneous Tissue Disorders						
Rash	29	1	0	7	0	0
Pruritus	14	<1	0	7	0	0
Dry skin	13	<1	0	5	0	0

	AFINITOR 10 mg/day N=274			Placebo N=137		
	All grades	Grade 3	Grade 4	All grades	Grade 3	Grade 4
	%	%	%	%	%	%
Metabolism and Nutrition Disorders						
Anorexia	25	1	0	14	<1	0
Hypercholesterolaemia	20	3	0	2	0	0
Hypertriglyceridaemia	15	1	0	2	0	0
Hyperglycaemia	12	6	0	2	1	0
Nervous System Disorders						
Headache	19	<1	<1	9	<1	0
Dysgeusia	10	0	0	2	0	0
Musculoskeletal and Connective Tissue Disorders						
Pain in extremity	10	1	0	7	0	0
Median Duration of Treatment (d)	141			60		

CTCAE Version 3.0

^a Stomatitis (including aphthous stomatitis), and mouth and tongue ulceration.

^b Includes all preferred terms within the 'infections and infestations' system organ class, the most common being nasopharyngitis (6%), pneumonia (6%), urinary tract infection (5%), bronchitis (4%), and sinusitis (3%), and also including aspergillosis (<1%), candidiasis (<1%) and sepsis (<1%).

^c Includes pneumonitis, interstitial lung disease, lung infiltration, pulmonary alveolar haemorrhage, pulmonary toxicity and alveolitis.

Other treatment-emergent adverse events occurring more frequently with AFINITOR than with placebo, but with an incidence of < 10% and considered clinically relevant include:

Gastrointestinal disorders: Abdominal pain (9%), dry mouth (8%), haemorrhoids (5%), dyspepsia (4%), dysphagia (4%), anal haemorrhage (<1%) haematochezia (<1%), melaena (<1%) and rectal haemorrhage (<1%)

General disorders and administration site conditions: Weight decreased (9%), chest pain (5%), chills (4%), impaired wound healing (<1%)

Investigations: Blood creatinine increased (9%)

Blood and lymphatic system disorders: Lymphopenia (8%), thrombocytopenia (7%), leucopenia (3%)

Respiratory, thoracic and mediastinal disorders: Pleural effusion (7%), pharyngolaryngeal pain (4%), rhinorrhoea (3%), pulmonary alveolar haemorrhage (<1%)

Skin and subcutaneous tissue disorders: Hand-foot syndrome (reported as palmar-plantar erythrodysesthesia syndrome) (5%), nail disorder (5%), erythema (4%), onychoclasia (4%), skin

lesion (4%), acneiform dermatitis (3%), acne (<1%), angioedema (0.7%)

Metabolism and nutrition disorders: Dehydration (5%), hypophosphataemia (5%), alanine aminotransferase increased (3%), aspartate aminotransferase increased (3%), hypocalcaemia (3%), exacerbation of pre-existing diabetes mellitus (2%), new-onset diabetes mellitus (<1%)

Psychiatric disorders: Insomnia (9%)

Nervous system disorders: Dizziness (7%), paraesthesia (5%), ageusia (1%)

Eye disorders: Eyelid oedema (4%), conjunctivitis (2%), retinal haemorrhage (<1%)

Vascular disorders: Hypertension (4%), haemorrhage (3%)[§], deep vein thrombosis (<1%)

Renal and urinary disorders: Renal failure (3%), acute renal failure (1%), increased daytime urination (2%), haematuria (2%)

Reproductive system and breast disorders: Vaginal haemorrhage (<1%)

Cardiac disorders: Tachycardia (3%), congestive cardiac failure (1%)

Musculoskeletal and connective tissue disorders: Jaw pain (3%)

[§]Excluding epistaxis

Abnormal Haematological and Clinical Chemistry Findings

Clinically relevant laboratory abnormalities are presented in Table 8.

Table 8 Clinically relevant laboratory abnormalities reported at a higher rate in the AFINITOR arm than in the placebo arm (mRCC)

Laboratory parameter	AFINITOR 10 mg/day N=274			Placebo N=137		
	All grades	Grade 3	Grade 4	All grades	Grade 3	Grade 4
	%	%	%	%	%	%
Haematology^a						
Haemoglobin decreased	92	12	1	79	5	<1
Lymphocytes decreased	51	16	2	28	5	0
Platelets decreased	23	1	0	2	0	<1
Neutrophils decreased	14	0	<1	4	0	0
Clinical chemistry						
Cholesterol increased	77	4	0	35	0	0
Triglycerides increased	73	<1	0	34	0	0
Glucose increased	57	15	<1	25	1	0
Creatinine increased	50	1	0	34	0	0
Phosphate decreased	37	6	0	8	0	0
Aspartate transaminase (AST) increased	25	<1	<1	7	0	0
Alanine transaminase (ALT) increased	21	1	0	4	0	0
Bilirubin increased	3	<1	<1	2	0	0

CTCAE Version 3.0

^a Includes reports of anaemia, leucopenia, lymphopenia, neutropenia, pancytopenia, thrombocytopenia

Adverse Events in Renal Angiomyolipoma associated with Tuberous Sclerosis Complex

Adverse Reaction Overview

The data described below reflect exposure to AFINITOR (10 mg/day) (n=79) vs. placebo (n=39) in a randomized double-blind, parallel-group, placebo-controlled, multi-centre phase III study for the treatment of patients who have renal angiomyolipoma associated with TSC (n=113) or with sporadic lymphangiomyomatosis (LAM) (n=5). The median age of patients was 31 years (range: 18 to 61 years), 89% were Caucasian, and 34% were male. The median duration of blinded study treatment was 48 weeks (range: 2 to 115 weeks) for patients receiving AFINITOR and 45 weeks (range: 9 to 115 weeks) for those receiving placebo.

The most common treatment-emergent adverse reaction irrespective of causality (incidence $\geq 30\%$) was stomatitis. The most common grade 3-4 adverse events (incidence $\geq 2\%$) were stomatitis, amenorrhoea and convulsion. The most common clinically relevant laboratory abnormalities (incidence $\geq 50\%$) were increased cholesterol and triglycerides and decreased haemoglobin. The most common clinically relevant grade 3/4 laboratory abnormality (incidence $\geq 2\%$) was decreased phosphate. A single death was reported in the AFINITOR arm as a result of

status epilepticus in a patient with a prior history of intractable seizures.

The rates of treatment-emergent adverse events resulting in permanent discontinuation were 4% and 10% for the AFINITOR and placebo treatment groups, respectively. Adverse reactions leading to permanent discontinuation in the AFINITOR arm were hypersensitivity/angioedema/bronchospasm, convulsion and decreased blood phosphorus. Dose adjustments (interruptions or reductions) due to adverse reactions were more frequent among patients in the AFINITOR arm than in the placebo arm (52% versus 21%, respectively). The most commonly occurring adverse reaction leading to AFINITOR dose adjustment or need for medical intervention was stomatitis.

Clinical Trial Adverse Reactions

Table 9 compares the incidence of treatment-emergent adverse events reported with an incidence of $\geq 10\%$ for patients receiving AFINITOR 10 mg daily or placebo and occurring more frequently with AFINITOR than with placebo.

Treatment-emergent adverse events in Table 9 are listed according to MedDRA system organ class. Within each system organ class, the adverse events are ranked by frequency, with the most frequent events first.

Table 9 Adverse events, irrespective of causality, reported in at least 10% of patients and at a higher rate in the AFINITOR arm than in the placebo arm (Renal Angiomyolipoma associated with TSC)

	AFINITOR 10 mg/day N=79			Placebo N=39		
	All grades	Grade 3	Grade 4	All grades	Grade 3	Grade 4
	%	%	%	%	%	%
Any Adverse Event	100	25	5	97	8	5
Blood and Lymphatic System Disorders						
Anaemia	11	0	0	3	0	0
Leukopenia	10	0	0	8	0	0
Gastrointestinal Disorders						
Stomatitis ^a	78	6	0	23	0	0
Nausea	16	0	0	13	0	0
Vomiting	15	0	0	5	0	0
Diarrhoea	14	0	0	5	0	0
Abdominal pain	11	0	0	8	3	0
General Disorders and Administration Site Conditions						
Oedema peripheral	13	1	0	8	0	0
Infections and Infestations						
Upper respiratory tract	11	0	0	5	0	0

	AFINITOR 10 mg/day N=79			Placebo N=39		
	All grades	Grade 3	Grade 4	All grades	Grade 3	Grade 4
	%	%	%	%	%	%
infection						
Investigations						
Blood lactate dehydrogenase increased	11	0	0	3	0	0
Metabolism and Nutrition Disorders						
Hypercholesterolaemia	23	1	0	3	0	0
Hypophosphataemia	11	0	0	3	0	0
Musculoskeletal and Connective Tissue Disorders						
Arthralgia	13	0	0	5	0	0
Nervous System Disorders						
Headache	22	0	0	21	3	0
Respiratory, Thoracic and Mediastinal Disorders						
Cough	20	0	0	13	0	0
Skin and Subcutaneous Tissue Disorders						
Acne	22	0	0	5	0	0
Rash ^b	11	0	0	0	0	0
Eczema	10	0	0	8	0	0

Grading according to CTCAE Version 3.0

^a Includes stomatitis, aphthous stomatitis, mouth ulceration, gingival pain, glossitis and glossodynia.

^b Includes rash, erythema, rash erythematous, palmar erythema, rash macular

Amenorrhoea (secondary) occurred in 15% of AFINITOR-treated females (8 of 52) and 4% (1 of 26) of females in the placebo group. Other adverse reactions involving the female reproductive system were menorrhagia (10%), menstrual irregularities (10%), vaginal haemorrhage (8%), menstruation delayed (2%) and oligomenorrhoea (2%).

Other treatment-emergent adverse reactions occurring more frequently with AFINITOR than with placebo, but with an incidence of < 10% and considered clinically relevant include:

Blood and lymphatic system disorders: Thrombocytopenia (8%)

Gastrointestinal disorders: Flatulence (6%), oral pain (1%)

Immune system disorders: Hypersensitivity (3%)

Infections and infestations: Otitis media (6%), sinusitis (6%), rash pustular (5%), oral herpes (4%), pneumonia (4%), gingivitis (1%)

Investigations: Carbon monoxide diffusing capacity decreased (9%), blood alkaline phosphatase increased (9%), gamma-glutamyltransferase increased (6%), blood phosphorus decreased (5%)

Metabolism and nutrition disorders: Hyperlipidaemia (8%), decreased appetite (6%), iron deficiency (6%)

Nervous system disorders: Migraine (5%), dysgeusia (4%), ageusia (1%)

Psychiatric disorders: Depression (5%), insomnia (4%), aggression (1%)

Respiratory, thoracic and mediastinal disorders: Epistaxis (9%), pneumonitis (1%)

Reproductive system and breast disorders: Blood luteinising hormone increased (4%), blood follicle stimulating hormone increased (3%), ovarian cyst (3%)

Skin and subcutaneous tissue disorders: Dry skin (9%), dermatitis acneiform (8%), angioedema (1%)

Vascular disorders: Hypertensive crisis (1%)

Abnormal Haematological and Clinical Chemistry Findings

Clinically relevant laboratory abnormalities are presented in Table 10 below.

Table 10 Clinically relevant laboratory abnormalities reported in at a higher rate in the AFINITOR arm than in the placebo arm (Renal Angiomyolipoma associated with TSC)

Laboratory parameter	AFINITOR 10 mg/day N=79			Placebo N=39		
	All grades %	Grade 3 %	Grade 4 %	All grades %	Grade 3 %	Grade 4 %
Haematology						
Haemoglobin decreased	61	0	0	49	0	0
White blood cells (WBC) decreased	37	0	0	21	0	0
Lymphocytes decreased	20	1	0	8	0	0
Platelets decreased	19	0	0	3	0	0
Clinical chemistry						
Cholesterol increased	85	1	0	46	0	0
Triglycerides increased	52	0	0	10	0	0
Phosphate decreased	49	5	0	15	0	0
Alkaline phosphatase increased	32	1	0	10	0	0

Laboratory parameter	AFINITOR 10 mg/day N=79			Placebo N=39		
	All grades %	Grade 3 %	Grade 4 %	All grades %	Grade 3 %	Grade 4 %
Aspartate transaminase (AST) increased	23	1	0	8	0	0
Alanine transaminase (ALT) increased	20	1	0	15	0	0
Glucose (fasting) increased	14	0	0	8	0	0

Grading according to CTCAE Version 3.0

Further long term follow-up with a median duration of exposure of 47 months resulted in the following additional key laboratory abnormalities: partial thromboplastin time increased (63%), prothrombin time increased (40%), fibrinogen decreased (38%); and notable adverse events: nasopharyngitis (44.6%), urinary tract infection (31%), proteinuria (18%), bronchitis (14.3%), pyrexia (13%), oropharyngeal pain (13%), pruritus (12%), gastroenteritis (12%), blood lactate dehydrogenase increased (11%), dizziness (11%) and myalgia (11%), dental conditions (tooth abscess [7.1%], tooth infection [6.3%], and periodontitis [5.4%]), and metrorrhagia (5.4%). Blood follicle stimulating hormone (FSH) increased and blood luteinizing hormone (LH) increased was reported in 2 male patients (5.1%; 2/39 male patients). One of these 2 patients also reported blood testosterone decreased (2.6%; 1/39 male patients).

Adverse Events in SEGA associated with Tuberous Sclerosis Complex

Adverse Reaction Overview

The data described below reflect exposure to AFINITOR (n=78) or placebo (n=39) in a randomized (2:1), double-blind, placebo-controlled, phase III trial in patients with subependymal giant cell astrocytoma (SEGA) associated with tuberous sclerosis complex (TSC) (N=117). The median age of patients was 9.5 years (range: 0.8 to 26.6 years), 93% were Caucasian and 57% were male. The median duration of blinded study treatment was 52 weeks (range: 24 to 89 weeks) for patients receiving AFINITOR and 47 weeks (range: 14 to 88 weeks) for those receiving placebo.

In the double-blind period of the trial, the most common treatment-emergent adverse event irrespective of causality reported for AFINITOR (incidence \geq 30%) was stomatitis. The most common grade 3-4 adverse reactions (incidence \geq 2%) were stomatitis, pyrexia, pneumonia, viral gastroenteritis, aggression, agitation, neutropenia and amenorrhoea. The most common key laboratory abnormalities (incidence \geq 50%) were cholesterol increased and elevated partial thromboplastin time. The most common grade 3-4 laboratory abnormality (incidence \geq 3%) was neutrophil count decreased

There were no adverse events resulting in permanent discontinuation. Dose adjustments (interruptions or reductions) due to adverse events occurred in 55% of AFINITOR-treated patients. The most common adverse event leading to AFINITOR dose adjustment was stomatitis.

Clinical Trial Adverse Reactions

Table 11 compares the incidence of treatment-emergent adverse events irrespective of causality reported with an incidence of $\geq 10\%$ for patients receiving AFINITOR and occurring more frequently with AFINITOR than with placebo.

Treatment-emergent adverse events in Table 11 are listed according to MedDRA system organ class. Within each system organ class, the adverse events are ranked by frequency, with the most frequent events first.

Table 11 Adverse events, irrespective of causality, reported in at least 10% of patients and at a higher rate in the AFINITOR arm than in the placebo arm (SEGA associated with TSC– Phase III Trial)

	AFINITOR N=78			Placebo N=39		
	All grades %	Grade 3 %	Grade 4 %	All grades %	Grade 3 %	Grade 4 %
Any adverse reaction	97	36	3	92	23	3
Gastrointestinal disorders						
Stomatitis ^a	62	9	0	26	3	0
Vomiting	22	1	0	13	0	0
Diarrhoea	17	0	0	5	0	0
Constipation	10	0	0	3	0	0
Infections and infestations						
Respiratory tract infection ^b	31	1	1	23	0	0
Gastroenteritis ^c	10	4	1	3	0	0
Pharyngitis streptococcal	10	0	0	3	0	0
Ear infection ^f	18	3	0	15	3	0
General disorders and administration site conditions						
Pyrexia	23	6	0	18	3	0
Fatigue	14	0	0	3	0	0
Psychiatric and behavioural disorder						
Anxiety, aggression or other behavioural disturbance ^d	21	5	0	3	0	0
Skin and subcutaneous tissue disorders						
Rash ^e	21	0	0	8	0	0
Acne	10	0	0	5	0	0
Grading according to CTCAE Version 3.0						

- ^a Includes mouth ulceration, stomatitis and lip ulceration
- ^b Includes respiratory tract infection, upper respiratory tract infection and respiratory tract infection viral
- ^c Includes gastroenteritis, gastroenteritis viral and gastrointestinal infection
- ^d Includes agitation, anxiety, panic attack, aggression, abnormal behaviour and obsessive compulsive disorder
- ^e Includes rash, rash generalized, rash macular, rash maculo-papular, rash papular, dermatitis allergic and urticaria
- ^f Includes otitis media, ear infection, ear infection bacterial, otitis media acute

Amenorrhoea (secondary) occurred in 17% (3 out of 18) of AFINITOR-treated females aged 10 to 55 years (age of oldest patient in this target range was 27 years) and in none of the females in the placebo group. For this same group of AFINITOR-treated females, the following menstrual abnormalities were reported: dysmenorrhoea (6%), menorrhagia (6%), metrorrhagia (6%) and unspecified menstrual irregularity (6%).

Other treatment-emergent adverse events occurring with AFINITOR with an incidence of < 10% and considered clinically relevant include:

Blood and Lymphatic Disorders: Neutropenia (6 %), anaemia (5 %)

Gastrointestinal disorders: Nausea (8%), oral pain (5%)

General disorders and administrative site conditions: Irritability (5%)

Immune system disorders: Hypersensitivity (3%)

Infections and infestations: Urinary tract infection (4%), gingivitis (4%), herpes zoster (1%)

Investigations: Blood luteinising hormone increased (1%)

Metabolism and Nutrition Disorders: Decreased appetite (9%), hypercholesterolaemia (6%)

Musculoskeletal and connective tissue disorder: Pain in extremity (8%)

Psychiatric disorders: Aggression (8%), insomnia (6%)

Respiratory, thoracic and mediastinal disorders: Pneumonia (6%), epistaxis (5%), pneumonitis (1%)

Abnormal Haematological and Clinical Chemistry Findings

Key laboratory abnormalities reported more frequently with AFINITOR than placebo are presented in Table 12.

Table 12 Laboratory abnormalities reported in at a higher rate in the AFINITOR arm than in the placebo arm (SEGA associated with TSC - Phase III Trial)

	AFINITOR N=78	Placebo N=39

	All grades %	Grade 3 %	Grade 4 %	All grades %	Grade 3 %	Grade 4 %
Haematology						
Elevated partial thromboplastin time	72	3	0	44	5	0
Neutrophils decreased	46	9	0	41	3	0
Haemoglobin decreased	41	0	0	21	0	0
Clinical chemistry						
Hypercholesterolemia	81	0	0	39	0	0
Elevated aspartate transaminase (AST)	33	0	0	0	0	0
Hypertriglyceridemia	27	0	0	15	0	0
Elevated alanine transaminase (ALT)	18	0	0	3	0	0
Hypophosphatemia	9	1	0	3	0	0

Grading according to CTCAE Version 3.0

Further long-term follow-up with a medium duration of exposure of 47 months resulted in the following additional notable adverse events and key laboratory abnormalities: nasopharyngitis (35%), cough (26%), pneumonia (25%), sinusitis (20%), bronchitis (18%), otitis media (18%), headache (15%), decreased appetite (14%), hyperglycemia (13%), hypertension (11%), urinary tract infection (9%), decreased fibrinogen (8%), oropharyngeal pain (6%), cellulitis (6%), abdominal pain (5%), weight decrease (5%), irritability (5%) and elevated creatinine (5%) and azoospermia (1%).

Clinical Trial Adverse Events in Patients with Seizures Associated with TSC

Adverse Reaction Overview

The data described below are based on a randomized, double-blind, multicenter, three-arm, parallel-group, phase-III study of AFINITOR DISPERZ versus placebo as adjunctive therapy conducted in patients with seizures associated with TSC. A total of 247 patients received AFINITOR DISPERZ (Low dose/low trough [LT] range: 3 to 7 ng/mL, n=117; High dose/high trough [HT] range: 9 to 15 ng/mL, n = 130) or placebo (n=119), added to each patient's concomitant AED therapy.

The most common adverse reactions reported for AFINITOR DISPERZ with an incidence \geq 20% (in either the LT or HT arms) were stomatitis (55% AFINITOR DISPERZ LT, 64% AFINITOR DISPERZ HT) and diarrhea (17%, 22%). The most common Grade 3-4 adverse reactions (incidence \geq 2%) were stomatitis (3%, 4%), neutropenia (2%, 2%), pneumonia (1%, 2%), and irregular menstruation (0%, 2%)(see Table 13). The most common clinically relevant laboratory abnormalities (incidence \geq 30%) were hypercholesterolemia (85%, 85%), hypertriglyceridemia (43%, 38%), neutropenia (25%, 37%), and anemia (26%, 30%). The most common clinically relevant Grade 3-4 laboratory abnormality (incidence \geq 2%) was neutropenia (4%, 6%) (see Table 14). The most common serious adverse events (incidence \geq 1%) were pneumonia (0.9%,

3%), status epilepticus (2%, 2%), headache (0%, 2%), seizure (2%, 0.8%), mouth ulceration (2%, 0%), pharyngitis (2%, 0%), and urinary tract infection (2%, 0%).

Adverse reactions leading to study drug discontinuation occurred in 5% and 3% of patients in the AFINITOR DISPERZ LT and HT arms, respectively, and in 2% of patients in the placebo arm. The most common adverse reaction (incidence \geq 1%) leading to AFINITOR DISPERZ discontinuation was stomatitis (2% AFINITOR DISPERZ LT, 2% AFINITOR DISPERZ HT, 0% placebo). Dose adjustments (interruptions or reductions) due to adverse reactions occurred in 24% and 35% of patients in the AFINITOR DISPERZ LT and HT arms, respectively (Placebo: 8%). The most common adverse reactions (incidence \geq 3%) leading to dose adjustments in the AFINITOR DISPERZ LT or HT arms were stomatitis (11%, 16%) including mouth ulceration (7%, 4%), pneumonia (0.9%, 4%), and pyrexia (3%, 2%).

Table 13 Adverse events, irrespective of causality, by MedDRA Preferred Term reported in at least 10% of patients and at a higher rate in the AFINITOR DISPERZ arm than in the placebo arm during the Core treatment phase (Seizures associated with TSC)

	AFINITOR DISPERZ						Placebo		
	LT target of 3-7 ng/mL			HT target of 9-15 ng/mL					
	N=117			N=130			N=119		
	All grades	Grade 3	Grade 4	All grades	Grade 3	Grade 4	All grades	Grade 3	Grade 4
	%	%	%	%	%	%	%	%	%
Any adverse reactions									
Gastrointestinal disorders									
Stomatitis ^a	55	3	0	64	4	0	9	0	0
Diarrhoea	17	0	0	22	0	0	5	0	0
Vomiting	12	0	0	10	2	0	9	0	0
Infections and infestations									
Nasopharyngitis	14	0	0	16	0	0	16	0	0
Upper respiratory tract infection	13	0	0	15	0	0	13	1	0
General disorders and administration site conditions									
Pyrexia	20	0	0	14	1	0	5	0	0
Respiratory, thoracic and mediastinal disorders									
Cough	11	0	0	10	0	0	3	0	0
Skin and subcutaneous tissue disorders									
Rash ^b	6	0	0	10	0	0	3	0	0

^aIncludes reports of stomatitis, mouth ulceration, aphthous ulcer, lip ulceration, tongue ulceration, mucosal inflammation, gingival pain
^bIncludes reports of rash, rash erythematous, rash generalized, erythema, rash maculo-papular, rash macular

Other adverse events occurring with AFINITOR DISPERZ treated patients with an incidence of < 10% and considered clinically relevant include (%AFINITOR DISPERZ LT, % AFINITOR DISPERZ HT):

Gastrointestinal disorders: constipation (0%, 4%), nausea (1%, 3%), flatulence (0%, 2%), gastritis (1%, 1%), abdominal pain (3%, 0%), abdominal pain upper (2%, 5%)

General disorders and administration site conditions: fatigue (3%, 5%)

Infections and infestations: pharyngitis (5%, 6%), pneumonia (2%, 4%), sinusitis (0.9%, 4%), urinary tract infection (3%, 2%), pharyngitis streptococcal (0%, 2%), gastroenteritis viral (0%, 1%), gingivitis (3%, 1%), otitis media (2%, 1%), cellulitis (1%, 1%)

Investigations: blood lactate dehydrogenase increased (0%, 1%), blood luteinizing hormone increased (1%, 0%)

Metabolism and nutritious disorders: decreased appetite (9%, 7%)

Nervous system disorders: headache (3%, 9%)

Psychiatric disorders: irritability (2%, 2%), aggression (2%, 1%), insomnia (3%, 1%)

Renal and urinary disorders: proteinuria (0%, 2%)

Reproductive and breast disorders: amenorrhea (7%, 3%; in female patients aged 10 to 55 years), irregular menstruation (7%, 9%; in female patients aged 10 to 55 years), menorrhagia (3%, 3%; in female patients aged 10 to 55 years)

Respiratory, thoracic and mediastinal disorders: epistaxis (3%, 5%), pneumonitis (0%, 1%)

Skin and subcutaneous tissue disorders: acne (3%, 6%), dry skin (3%, 2%)

Vascular disorders: hypertension (2%, 2%)

Abnormal Haematological and Clinical Chemistry Findings

Clinically relevant laboratory abnormalities reported more frequently with AFINITOR DISPERZ than placebo are presented in Table 14.

Table 14 Clinically relevant laboratory abnormalities reported in at a higher rate in the AFINITOR DISPERZ arm than in the placebo arm during the Core treatment phase (Seizures associated with TSC)

	AFINITOR DISPERZ						Placebo		
	LT target of 3-7 ng/mL			HT target of 9-15 ng/mL					
	N=117			N=130			N=119		
	All grades	Grade 3	Grade 4	All grades	Grade 3	Grade 4	All grades	Grade 3	Grade 4

	%	%	%	%	%	%	%	%	%
Hematology									
Neutropenia	25	4	0	37	5	0.8	23	7	0
Anemia	27	1	0	30	0	0	21	1	0
Leukopenia	14	0	0	25	0	0	18	0	0
Thrombocytopenia	12	0	0	15	0	0	6	0	0
Clinical Chemistry									
Hypercholesterolemia	85	0	0	85	0.8	0	58	0	0
Hypertriglyceridemia	43	2	0	38	0.8	0.8	22	0	0
Elevated alanine transaminase (ALT)	17	0	0	22	0	0	6	0	0
Elevated aspartate transaminase (AST)	13	0	0	18	0	0	4	0	0
Hyperglycemia	19	0	0	18	0	0	17	0	0
Elevated alkaline phosphatase	24	0	0	16	0	0	29	0	0
Hypophosphatemia	9	1	0	16	0.8	0.8	3	0	0
Grading according to CTCAE version 4.03									

Updated safety information from 361 patients treated with AFINITOR DISPERZ in the Core and/or Extension treatment phases for a median duration of 20.8 (0.5 to 37.9) months identified the following additional notable adverse reactions: angioedema (0.3%) and sepsis (0.8%).

Post-Market Adverse Reactions

Other adverse drug reactions are presented below; some of them are reported spontaneously. Because spontaneous events are reported voluntarily from a population of uncertain size, it is not always possible to reliably estimate their frequency or clearly establish a causal relationship to AFINITOR exposure.

Blood and lymphatic system disorders: febrile neutropenia

Immune system disorders: hepatitis B reactivation, including fatal outcome (reactivation of infections is an expected event during periods of immunosuppression), angioedema with and without concomitant use of ACE inhibitors

Infections and infestations: pneumocystis jirovecii pneumonia (PJP)

Musculoskeletal and connective tissue disorders: rhabdomyolysis

Renal and urinary disorders: renal failure events, including fatal outcome (monitoring of renal function is recommended), proteinuria

Reproductive system and breast disorders: secondary amenorrhoea

Respiratory, thoracic and mediastinal disorders: pulmonary embolism

DRUG INTERACTIONS

Overview

Everolimus is a substrate of CYP3A4, and also a substrate and moderate inhibitor of the multidrug efflux pump PgP. Therefore, absorption and subsequent elimination of everolimus may be influenced by products that affect CYP3A4 and/or PgP.

In vitro, everolimus is a competitive inhibitor of CYP3A4 and a mixed inhibitor of CYP2D6.

Drug-Drug Interactions

Agents that may increase everolimus blood concentrations:

Everolimus blood concentrations may be increased by substances that inhibit CYP3A4 activity and thus decrease everolimus metabolism.

Everolimus blood concentrations may be increased by inhibitors of PgP that may decrease the efflux of everolimus from intestinal cells.

Concurrent treatment with strong inhibitors of CYP3A4 and/or PgP (including but not limited to ketoconazole, itraconazole, voriconazole, atazanavir, indinavir, nelfinavir, ritonavir, saquinavir, nefazodone, clarithromycin and telithromycin) should be avoided.

There was a significant increase in exposure to everolimus (C_{max} and AUC increased by 3.9- and 15.0-fold, respectively) in healthy subjects when everolimus was co-administered with ketoconazole (a strong inhibitor of CYP3A4 and PgP).

Concomitant treatment with moderate inhibitors of CYP3A4 (including, but not limited to, erythromycin, verapamil, cyclosporine, fluconazole, diltiazem, amprenavir, fosamprenavir or aprepitant) and moderate PgP inhibitors requires caution. Reduce the AFINITOR or AFINITOR DISPERZ dose if co-administered with moderate inhibitors of CYP3A4 and/or PgP (see **DOSAGE AND ADMINISTRATION** and **WARNINGS AND PRECAUTIONS**).

There was an increase in exposure to everolimus in healthy subjects when everolimus was co-administered with:

- erythromycin (a moderate inhibitor of CYP3A4 and an inhibitor of PgP; C_{max} and AUC increased by 2.0- and 4.4-fold, respectively).
- verapamil (a moderate inhibitor of CYP3A4 and an inhibitor of PgP; C_{max} and AUC increased by 2.3- and 3.5-fold, respectively).
- cyclosporine (a CYP3A4 substrate and an inhibitor of PgP; C_{max} and AUC increased by 1.8- and 2.7-fold, respectively).

Agents that may decrease everolimus blood concentrations:

Substances that are inducers of CYP3A4 and/or PgP may decrease everolimus blood concentrations by increasing the metabolism or the efflux of everolimus from intestinal cells.

Concurrent treatment with strong inducers of CYP3A4 and/or PgP should be avoided. If AFINITOR or AFINITOR DISPERZ must be co-administered with a strong inducer of CYP3A4 and/or PgP (e.g. rifampicin and rifabutin), it may be necessary to adjust the AFINITOR or AFINITOR DISPERZ dose (see **DOSAGE AND ADMINISTRATION** and **WARNINGS AND PRECAUTIONS**).

Pre-treatment of healthy subjects with multiple doses of rifampicin (a strong inducer of CYP3A4 and PgP) 600 mg daily for 8 days followed by a single dose of everolimus, increased everolimus oral-dose clearance nearly 3-fold and decreased C_{max} by 58% and AUC by 63%.

Other strong inducers of CYP3A4 and/or PgP that may increase the metabolism of everolimus and decrease everolimus blood levels include St. John's wort (*Hypericum perforatum*), anticonvulsants (e.g. carbamazepine, phenobarbital, phenytoin) and anti-HIV agents (e.g. efavirenz, nevirapine).

Agents whose plasma concentrations may be altered by everolimus:

Studies in healthy subjects indicate that there are no clinically significant pharmacokinetic interactions between AFINITOR and the HMG-CoA reductase inhibitors atorvastatin (a CYP3A4 substrate) and pravastatin (a non-CYP3A4 substrate) and population pharmacokinetic analyses also detected no influence of simvastatin (a CYP3A4 substrate) on the clearance of everolimus. However, these studies were carried out with a 2 mg oral dose of everolimus. The effects of a 10 mg dose have not been studied and therefore pharmacological interactions cannot be ruled out in this setting.

Everolimus may inhibit the metabolism of substrates of CYP3A4 including statins (HMG-CoA reductase inhibitors). Caution should be exercised if a statin is prescribed for hyperlipidaemia, since the risk of developing rhabdomyolysis may be increased with statin use (see **WARNINGS AND PRECAUTIONS, Musculoskeletal and Connective Tissue Disorders**).

In vitro, everolimus competitively inhibited the metabolism of the CYP3A4 substrate cyclosporine and was a mixed inhibitor of the CYP2D6 substrate dextromethorphan. The mean steady-state of everolimus C_{max} with an oral dose of 10 mg daily or 70 mg weekly is more than 12- to 36-fold below the K_i -values of the *in vitro* inhibition. An effect of everolimus on the metabolism of CYP3A4 and CYP2D6 substrates was therefore considered to be unlikely.

The effect of everolimus on the pharmacokinetics of the CYP3A4 substrate midazolam has been studied in healthy subjects. Co-administration of an oral dose of midazolam with everolimus resulted in a 25% increase in midazolam C_{max} and a 30% increase in midazolam $AUC_{(0-inf)}$, whereas the metabolic $AUC_{(0-inf)}$ ratio (1-hydroxy-midazolam/midazolam) and the terminal $t_{1/2}$ of midazolam were not affected. This indicates that everolimus may increase the blood concentration of orally administered CYP3A4 substrates. Interaction between everolimus and non-orally administered CYP3A4 substrates has not been studied (see **WARNINGS AND PRECAUTIONS**).

Everolimus increased pre-dose concentrations of the antiepileptic drugs (AEDs) carbamazepine, clobazam, and the clobazam metabolite N-desmethyloclobazam by about 10%. The increase in the

pre-dose concentrations of these AEDs may not be clinically significant but dose adjustments for AEDs with a narrow therapeutic index e.g. carbamazepine may be considered.

CYP3A4 Substrates (AEDs)

Everolimus had no impact on pre-dose concentrations of AEDs that are substrates of CYP3A4 (clonazepam, diazepam, felbamate and zonisamide).

Other Anti-Epileptic Drugs (AEDs)

Everolimus had no impact on the pre-dose concentration of other AEDs, including valproic acid, topiramate, oxcarbazepine, phenobarbital, phenytoin and primidone

Co-administration of everolimus and depot octreotide increased octreotide C_{min} with a geometric mean ratio (everolimus/placebo) of 1.47 (90% CI: 1.32 to 1.64).

Co-administration of AFINITOR and exemestane (a drug which is metabolized in part by CYP3A4) increased exemestane C_{min} and C_{2h} by 45% and 71%, respectively. However, the corresponding oestradiol levels at steady state (4 weeks) were not different between the two treatment arms. No increase in adverse events related to exemestane was observed in patients with hormone receptor-positive, HER2-negative advanced breast cancer receiving the combination.

Pharmacodynamic drug interactions:

Patients taking concomitant ACE inhibitor therapy may be at increased risk for angioedema (e.g. swelling of the airways or tongue, with or without respiratory impairment). The nature of the pharmacodynamic interaction has not been established (see **WARNINGS AND PRECAUTIONS, General, Drug-Drug Interactions**).

Vaccinations:

Immunosuppressants may affect the response to vaccination and vaccination during treatment with AFINITOR or AFINITOR DISPERZ may therefore be less effective. The use of live vaccines should be avoided during treatment with AFINITOR or AFINITOR DISPERZ (see **WARNINGS AND PRECAUTIONS**). Examples of live vaccines are: intranasal influenza, measles, mumps, rubella, oral polio, BCG, yellow fever, varicella, and TY21, a typhoid vaccine.

For paediatric patients with SEGA and/or seizures associated with TSC who do not require immediate treatment, complete the recommended childhood series of live vaccinations prior to the start of therapy. An accelerated vaccination schedule may be appropriate.

Drug-Food Interactions

Grapefruit, grapefruit juice, star fruit, Seville oranges, and other foods that are known to inhibit cytochrome P450 and P-gP activity may increase everolimus exposures and should be avoided during treatment.

Drug-Herb Interactions

St. John's wort (*Hypericum perforatum*) is an inducer of CYP3A4 that may increase the metabolism of everolimus and decrease everolimus blood levels and should be avoided.

Drug-Laboratory Test Interactions

Interactions between AFINITOR or AFINITOR DISPERZ and laboratory tests have not been studied.

DOSAGE AND ADMINISTRATION

Dosing Considerations

AFINITOR and AFINITOR DISPERZ should be prescribed by a qualified healthcare professional who is experienced in the use of antineoplastic therapy and/or in the treatment of patients with TSC.

AFINITOR (everolimus) is available in two dosage forms, tablets (AFINITOR) and tablets for oral suspension (AFINITOR DISPERZ). AFINITOR and AFINITOR DISPERZ are **not** interchangeable and should **not** be combined to achieve the desired dose (see **Switching dosage forms** below).

AFINITOR Tablets

AFINITOR (tablets) may be used in all approved oncology indications and for the renal angiomyolipoma associated with tuberous sclerosis complex (TSC) and subependymal giant cell astrocytoma (SEGA) associated with TSC indications. For patients with SEGA associated with TSC, AFINITOR must be used in conjunction with therapeutic drug monitoring (see **Therapeutic drug monitoring for patients treated for SEGA and/or seizures associated with TSC** below).

AFINITOR (tablets) have not been studied and should not be used in patients with seizures associated with TSC.

AFINITOR DISPERZ (Tablets for Oral Suspension)

AFINITOR DISPERZ (tablets for oral suspension) should only be used for the treatment of patients with SEGA and/or seizures associated with TSC. For patients with SEGA and/or seizures associated with TSC, AFINITOR DISPERZ must be used in conjunction with therapeutic drug monitoring (see **Therapeutic drug monitoring for patients treated for SEGA and/or seizures associated with TSC** below).

AFINITOR and AFINITOR DISPERZ should be administered orally once daily at the same time every day (preferably in the morning), either consistently with food or consistently without food (see **ACTION AND CLINICAL PHARMACOLOGY**).

Management of Adverse Reactions:

Management of severe or intolerable suspected adverse drug reactions may require temporary dose interruption (with or without dose reduction) or discontinuation of AFINITOR or AFINITOR DISPERZ therapy. If dose reduction is required, the suggested dose is approximately 50% lower than the dose previously administered (see **Table 15** and **WARNINGS AND PRECAUTIONS**). For dose reductions below the lowest available tablet strength, alternate day dosing should be considered.

Table 15 summarizes recommendations for dose interruption, reduction, or discontinuation of AFINITOR or AFINITOR DISPERZ in the management of adverse reactions. General management recommendations are also provided as applicable. Clinical judgment of the treating physician should guide the management plan of each patient based on individual benefit/risk assessment.

Table 15 AFINITOR or AFINITOR DISPERZ dose adjustment and management recommendations for adverse drug reactions

Adverse Drug Reaction	Severity^a	AFINITOR or AFINITOR DISPERZ Dose Adjustment^b and Management Recommendations
Non-infectious pneumonitis	Grade 1 Asymptomatic, clinical or diagnostic observations only; intervention not indicated	No dose adjustment required. Initiate appropriate monitoring.
	Grade 2 Symptomatic, medical intervention indicated; limiting instrumental ADL ^c	Consider interruption of therapy, rule out infection and consider treatment with corticosteroids until symptoms improve to ≤ Grade 1. Re-initiate treatment at a lower dose. Discontinue treatment if failure to recover within 4 weeks.
	Grade 3 Severe symptoms; limiting self-care ADL ^c ; O ₂ indicated	Interrupt treatment until symptoms resolve to ≤ grade 1. Rule out infection and consider treatment with corticosteroids. Consider re-initiating treatment at a lower dose. If toxicity recurs at Grade 3, consider discontinuation.
	Grade 4 Life-threatening respiratory compromise; urgent intervention indicated (e.g., tracheotomy or intubation)	Discontinue treatment, rule out infection, and consider treatment with corticosteroids.

Adverse Drug Reaction	Severity^a	AFINITOR or AFINITOR DISPERZ Dose Adjustment^b and Management Recommendations
Stomatitis	Grade 1 Asymptomatic or mild symptoms, intervention not indicated	No dose adjustment required. Manage with non-alcoholic or salt water (0.9%) mouth wash several times a day.
	Grade 2 Moderate pain; not interfering with oral intake; modified diet indicated	Temporary dose interruption until recovery to grade ≤ 1 . Re-initiate treatment at the same dose. If stomatitis recurs at Grade 2, interrupt dose until recovery to Grade ≤ 1 . Re-initiate treatment at a lower dose. Manage with topical analgesic mouth treatments (e.g. benzocaine, butyl aminobenzoate, tetracaine hydrochloride, menthol or phenol) with or without topical corticosteroids (i.e. triamcinolone oral paste). ^d
	Grade 3 Severe pain; interfering with oral intake	Temporary dose interruption until recovery to Grade ≤ 1 . Re-initiate treatment at a lower dose. Manage with topical analgesic mouth treatments (i.e. benzocaine, butyl aminobenzoate, tetracaine hydrochloride, menthol or phenol) with or without topical corticosteroids (i.e. triamcinolone oral paste). ^d
	Grade 4 Life-threatening consequences; urgent intervention indicated	Discontinue treatment and treat with appropriate medical therapy.
Other non-haematologic toxicities (excluding metabolic events)	Grade 1	If toxicity is tolerable, no dose adjustment required. Initiate appropriate medical therapy and monitor.
	Grade 2	If toxicity is tolerable, no dose adjustment required. Initiate appropriate medical therapy and monitor. If toxicity becomes intolerable, temporary dose interruption until recovery to Grade ≤ 1 . Re-initiate treatment at the same dose. If toxicity recurs at Grade 2, interrupt treatment until recovery to Grade ≤ 1 . Re-initiate treatment at a lower dose.
	Grade 3	Temporary dose interruption until recovery to grade ≤ 1 . Initiate appropriate medical therapy and monitor. Consider re-initiating treatment at a lower dose.

Adverse Drug Reaction	Severity ^a	AFINITOR or AFINITOR DISPERZ Dose Adjustment ^b and Management Recommendations
		If toxicity recurs at Grade 3, consider discontinuation.
	Grade 4	Discontinue treatment and treat with appropriate medical therapy.
Metabolic events (e.g. hyperglycaemia, dyslipidaemia)	Grade 1	No dose adjustment required. Initiate appropriate medical therapy and monitor.
	Grade 2	No dose adjustment required. Manage with appropriate medical therapy and monitor.
	Grade 3	Temporary dose interruption. Re-initiate treatment at a lower dose. Manage with appropriate medical therapy and monitor.
	Grade 4	Discontinue treatment and treat with appropriate medical therapy.
Thrombocytopenia (Platelet count decreased)	Grade 1 (<LLN ^e - 75.0 x 10 ⁹ /L)	No dose adjustment required.
	Grade 2 (<75.0 - 50.0 x 10 ⁹ /L)	Temporary dose interruption until recovery to Grade ≤1. Re-initiate treatment at the same dose.
	Grade 3 (<50.0 - 25.0 x 10 ⁹ /L)	Temporary dose interruption until recovery to Grade ≤1. Re-initiate treatment at a lower dose.
	Grade 4 (<25.0 x 10 ⁹ /L)	Temporary dose interruption until recovery to Grade ≤1. Re-initiate treatment at a lower dose.
Neutropenia (Neutrophil count decreased)	Grade 1 (<LLN ^e - 1.5 x 10 ⁹ /L)	No dose adjustment required.
	Grade 2 (<1.5 - 1.0 x 10 ⁹ /L)	No dose adjustment required.
	Grade 3 (<1.0 - 0.5 x 10 ⁹ /L)	Temporary dose interruption until recovery to Grade ≤2. Re-initiate treatment at the same dose.
	Grade 4 (<0.5 x 10 ⁹ /L)	Temporary dose interruption until recovery to Grade ≤2. Re-initiate treatment at a lower dose.
Febrile neutropenia	Grade 3 ANC ^f <1.0 x 10 ⁹ /L with a single temperature of >38.3°C (101°F) or a	Temporary dose interruption until recovery of ANC to ≥ 1.25 x 10 ⁹ /L and no fever. Re-initiate treatment at a lower dose.

Adverse Drug Reaction	Severity ^a	AFINITOR or AFINITOR DISPERZ Dose Adjustment ^b and Management Recommendations
	sustained temperature of $\geq 38^{\circ}\text{C}$ (100.4°F) for more than one hour.	
	Grade 4 Life-threatening consequences; urgent intervention indicated	Discontinue treatment.

^a Severity grade description: 1 = mild symptoms; 2 = moderate symptoms; 3 = severe symptoms; 4 = life-threatening symptoms.

Grading based on National Cancer Institute (NCI) Common Terminology Criteria for Adverse Events (CTCAE) v4.03.

^b If dose reduction is required, the suggested dose is approximately 50% lower than the dose previously administered.

^c Activities of daily living (ADL)

^d Avoid using agents containing alcohol, hydrogen peroxide, iodine, and thyme derivatives in management of stomatitis as they may worsen mouth ulcers. Antifungal agents should not be used, unless an oral fungal infection has been diagnosed, in which case oral topical antifungal agents are preferred.

^e Lower limit of normal (LLN)

^f Absolute Neutrophil Count (ANC)

Moderate inhibitors of CYP3A4 and/or PgP: Use caution when administering AFINITOR in combination with moderate inhibitors of CYP3A4 (e.g., amprenavir, fosamprenavir, aprepitant, erythromycin, fluconazole, verapamil, diltiazem) or PgP. If patients require co-administration of a moderate inhibitor of CYP3A4 or PgP, reduce the AFINITOR or AFINITOR DISPERZ daily dose by approximately 50%. Further dose reduction may be required to manage adverse reactions. For dose reductions below the lowest available strength, alternate day dosing should be considered (see **WARNING AND PRECAUTIONS** and **DRUG INTERACTIONS**).

Hormone receptor-positive, HER-2 negative advanced breast cancer, advanced NET, metastatic renal cell carcinoma and renal angiomyolipoma associated with TSC: If the moderate inhibitor of CYP3A4/PgP is discontinued, consider a washout period of at least 3 days, or four drug elimination half-lives, before the AFINITOR dose is increased. The AFINITOR dose should be returned to the dose used prior to initiation of the moderate inhibitor of CYP3A4 or PgP (see **WARNING AND PRECAUTIONS** and **DRUG INTERACTIONS**).

SEGA and/or seizures associated with TSC: Everolimus trough concentrations should be assessed approximately 1 to 2 weeks after the addition of a moderate inhibitor of CYP3A4/PgP. If the moderate inhibitor is discontinued, the AFINITOR or AFINITOR DISPERZ dose should be returned to the dose used prior to initiation of the inhibitor and the everolimus trough concentration should be re-assessed approximately 2 weeks later (see **WARNINGS AND PRECAUTIONS** and **DRUG INTERACTIONS**).

Strong inhibitors of CYP3A4/PgP: Avoid the use of concomitant strong inhibitors of CYP3A4 (e.g., ketoconazole, itraconazole, clarithromycin, atazanavir, nefazodone, saquinavir, telithromycin, ritonavir, indinavir, nelfinavir, voriconazole) or PgP, due to the risk of reduced

effectiveness of the drug (see **WARNINGS AND PRECAUTIONS** and **DRUG INTERACTIONS**).

Grapefruit, grapefruit juice, star fruit, Seville oranges and other foods that are known to inhibit cytochrome P450 and P-gP activity should be avoided during treatment (see **WARNINGS AND PRECAUTIONS** and **DRUG INTERACTIONS**).

Strong inducers of CYP3A4: Avoid the use of concomitant strong inducers of CYP3A4 (e.g., anticonvulsants [such as carbamazepine, oxcarbazepine, phenobarbital and phenytoin]; St. John's Wort [*Hypericum perforatum*]; rifampin, rifabutin, rifapentine). If AFINITOR must be co-administered with a strong CYP3A4/P-gP inducer, the patient should be carefully monitored for clinical response. Consider a dose increase of AFINITOR when co-administered with strong CYP3A4/P-gP inducers if alternative treatment is not possible.

Renal angiomyolipoma associated with TSC:

If patients with renal angiomyolipoma associated with TSC require co-administration of an anticonvulsant that is a strong inducer of CYP3A4, consider increasing the AFINITOR recommended dose up to 20 mg daily, using increments of 5 mg or less. This dose of AFINITOR is predicted, based on pharmacokinetic data, to adjust the AUC to the range observed without inducers. However, there are limited clinical data with this dose adjustment in patients with renal angiomyolipoma receiving an anticonvulsant which is a strong inducer of CYP3A4. If the anticonvulsant that is a strong inducer of CYP3A4 is discontinued, the AFINITOR dose should be returned to the dose used prior to initiation of the anticonvulsant.

SEGA associated with TSC:

Patients who have SEGA associated with TSC who are receiving concomitant strong inducers of CYP3A4 at the start of everolimus treatment may require an increased AFINITOR or AFINITOR DISPERZ dose to attain trough concentrations of 5 to 15 ng/mL. The daily dose may be increased by 2.5 mg every 2 weeks for AFINITOR and by 2 mg every 2 weeks for AFINITOR DISPERZ (see **Therapeutic drug monitoring for patients treated for SEGA and/or seizures associated with TSC** below, **WARNINGS AND PRECAUTIONS** and **DRUG INTERACTIONS**).

For patients who have SEGA associated with TSC who are not receiving concomitant strong inducers at the start of everolimus treatment, the addition of a strong inducer may require an increased AFINITOR or AFINITOR DISPERZ dose. Double the daily dose of AFINITOR or AFINITOR DISPERZ and assess tolerability. Determine the everolimus trough level two weeks after doubling the dose. Further adjust the dose if necessary by increments of 1 to 4 mg as necessary to maintain the target trough concentration (see **Therapeutic drug monitoring for patients treated for SEGA and/or seizures associated with TSC** below).

Seizures associated with TSC:

For patients with seizures associated with TSC receiving concomitant strong CYP3A4 inducers (e.g., enzyme inducing antiepileptic drugs carbamazepine, phenobarbital, and phenytoin) at the start of treatment with everolimus, increase the starting dose of AFINITOR DISPERZ to attain trough concentrations of 5 to 15 ng/mL (see recommendations outlined in Table 16). Further

adjust the dose by increments of 1 to 4 mg as necessary to maintain the target trough concentration (see **Therapeutic drug monitoring for patients treated for SEGA and/or seizures associated with TSC** below, **WARNINGS AND PRECAUTIONS** and **DRUG INTERACTIONS**).

If patients with seizures associated with TSC are not receiving concomitant strong inducers at the start of AFINITOR DISPERZ treatment, the addition of a strong inducer may require an increased AFINITOR DISPERZ dose. Double the daily dose of AFINITOR DISPERZ and assess tolerability. Assess the everolimus trough level two weeks after doubling the dose. Further adjust the dose if necessary by increments of 1 to 4 mg as necessary to maintain the target trough concentration (see **Therapeutic drug monitoring for patients treated for SEGA and/or seizures associated with TSC** below).

SEGA and/or seizures associated with TSC:

The addition of another concomitant strong CYP3A4 inducer may not require additional dose adjustment. Determine the everolimus trough level two weeks after initiating the additional inducer. Adjust the dose in 1 to 4 mg increments as necessary to maintain the target trough concentration (see **Therapeutic drug monitoring for patients treated for SEGA and/or seizures associated with TSC** below).

Discontinuation of one of multiple strong CYP3A4 inducers may not require additional dose adjustment. Determine the everolimus trough level two weeks after discontinuation of one of multiple strong CYP3A4 inducers (see **Therapeutic drug monitoring for patients treated for SEGA and/or seizures associated with TSC** below). If all strong inducers are discontinued, impose a washout period of at least 5 days (reasonable time for significant enzyme de-induction) before the AFINITOR or AFINITOR DISPERZ dose is returned to the dose used prior to initiation of the strong CYP3A4 inducer. Determine the everolimus trough concentration approximately 2 weeks later (see **DRUG INTERACTIONS**).

Hormone Receptor-Positive, HER2-Negative Advanced Breast Cancer, Advanced NET, Metastatic RCC and Renal Angiomyolipoma associated with TSC

Recommended Dose and Dosage Adjustment

The recommended dose of AFINITOR for the treatment of hormone receptor-positive, HER2-negative advanced breast cancer, advanced NET, metastatic RCC and renal angiomyolipoma associated with TSC is 10 mg, to be taken once daily.

Hormone Receptor-Positive, HER2-Negative Advanced Breast Cancer: Treatment with AFINITOR and exemestane should continue as long as clinical benefit is observed or until unacceptable toxicity occurs.

Advanced NET and Metastatic RCC: Treatment with AFINITOR should continue as long as clinical benefit is observed or until unacceptable toxicity occurs.

Renal Angiomyolipoma associated with Tuberous Sclerosis Complex: Optimal duration of

treatment with AFINITOR is not known.

Special Populations and Conditions

Geriatrics (≥ 65 years):

No dosage adjustment is required for elderly patients (see **ACTION AND CLINICAL PHARMACOLOGY, Special Populations and Conditions, Geriatrics**).

Paediatrics (< 18 years):

AFINITOR or AFINITOR DISPERZ is not recommended for use in paediatric patients with renal angiomyolipoma associated with TSC.

Renal impairment:

No studies with AFINITOR in patients with impaired renal function have been carried out. However, given that renal metabolism and clearance of AFINITOR is minimal (< 5% of total), no dosage adjustment is recommended (see **ACTION AND CLINICAL PHARMACOLOGY, Special Populations and Conditions, Renal Impairment**)

Hepatic impairment:

- Mild hepatic impairment (Child-Pugh A) – the recommended dose is 7.5 mg daily; the dose may be decreased to 5 mg if not well tolerated
- Moderate hepatic impairment (Child-Pugh B) – the recommended dose is 5 mg daily; the dose may be decreased to 2.5 mg if not well tolerated
- Severe hepatic impairment (Child-Pugh C) – if the potential benefit outweighs the risk, a dose of 2.5 mg daily may be used but must not be exceeded.

Dose adjustments should be made if a patient's hepatic (Child-Pugh) status changes during treatment.

Missed Dose

AFINITOR can still be taken up to 6 hours after the time it is normally taken. After more than 6 hours, the dose should be skipped for that day. The next day, AFINITOR should be taken at its usual time. Double doses should not be taken to make up for the one that was missed.

Administration

AFINITOR

AFINITOR tablets should be swallowed whole with a glass of water. The tablets should not be chewed or crushed.

SEGA and/or seizures associated with Tuberous Sclerosis Complex

Recommended Dose and Dosage Adjustment

Individualise dosing based on body surface area (BSA, in m²), calculated using the Dubois formula³.

Titration may be required to attain target everolimus trough concentrations, followed by optimal therapeutic effect within this range. Doses that are tolerated and effective vary between patients. Concomitant antiepileptic therapy may affect the metabolism of everolimus and may contribute to this variance (see **DRUG INTERACTIONS** and **Therapeutic drug monitoring for patients treated for SEGA and/or seizures associated with TSC**).

Starting dose and target trough concentrations in SEGA associated with TSC

The recommended starting daily dose for AFINITOR or AFINITOR DISPERZ for the treatment of patients with SEGA associated with TSC is 4.5 mg/m², rounded to the nearest strength of AFINITOR or AFINITOR DISPERZ. Different strengths of AFINITOR can be combined to attain the desired dose. Likewise, different strengths of AFINITOR DISPERZ can be combined to attain the desired dose. The two dosage forms should **not** be combined to achieve the desired dose.

Dosing should be titrated with the objective of attaining everolimus trough concentrations of 5 to 15 ng/mL, subject to tolerability.

Starting dose and target trough concentrations in seizures associated with TSC

The recommended starting daily dose for AFINITOR DISPERZ for the treatment of seizures associated with TSC is shown in Table 16. The starting dose should be rounded to the nearest available strength of AFINITOR DISPERZ. Different strengths of AFINITOR DISPERZ can be combined to attain the desired dose. Dosing should be titrated to attain trough concentrations of 5 to 15 ng/mL.

Table 16 **AFINITOR DISPERZ starting dose in TSC with refractory seizures**

Age	Starting dose without co-administration of CYP3A4/PgP inducer	Starting dose with co-administration of CYP3A4/PgP inducer
<6 years	6 mg/m ²	9 mg/m ²
≥6 years	5 mg/m ²	8 mg/m ²

AFINITOR DISPERZ is the only formulation that should be used for the treatment of patients with seizures associated with TSC.

³ BSA = (W^{0.425} x H^{0.725}) x 0.007184 (weight (W) is in kilograms and height (H) is in centimetres)

Dose titration for SEGA (AFINITOR and AFINITOR DISPERZ) and/or seizures (AFINITOR DISPERZ) associated with TSC.

Individualized dosing should be titrated by increasing the dose by increments of 1 to 4 mg of everolimus to attain the target trough concentration for optimal clinical response. Efficacy, safety, concomitant medication, and the current trough concentration should be considered when planning for dose titration. Individualized dose titration can be based on simple proportion:

New everolimus dose = current everolimus dose x (target concentration/current concentration)

The trough concentration should then be assessed 1 to 2 weeks after this change in dose.

Therapeutic drug monitoring for SEGA and/or seizures associated with TSC

Therapeutic drug monitoring of everolimus whole blood concentrations is **required** for patients treated for SEGA and/or seizures associated with TSC. A validated bioanalytical assay that is specific for everolimus, for example LC/MS, should be used. When possible, the same assay and laboratory should be used for therapeutic drug monitoring throughout treatment.

Everolimus whole blood trough concentrations should be assessed approximately 1 to 2 weeks after the initial dose, after any change in dose or dosage form (between AFINITOR and AFINITOR DISPERZ), after an initiation or change in co-administration of inducers or inhibitors of CYP3A4 /PgP (see **WARNINGS AND PRECAUTIONS** and **DRUG INTERACTIONS**) or after any change in hepatic (Child-Pugh) status (see **Recommended Dose and Dosage Adjustment**, **Patients with hepatic impairment** below and **ACTION AND CLINICAL PHARMACOLOGY**).

Long-term dose monitoring

For patients with SEGA and/or seizures associated with TSC, once a stable dose is attained, monitor trough concentrations every 3 to 6 months in patients with changing body surface area or every 6 to 12 months in patients with stable body surface area for the duration of treatment.

Switching dosage forms

The two dosage forms (AFINITOR and AFINITOR DISPERZ) are **not** interchangeable. Do not combine the two dosage forms to achieve the desired dose. Consistently use the same dosage form, as appropriate for the indication being treated (see **DOSAGE AND ADMINISTRATION**, **Dosing Considerations**).

SEGA volume monitoring for patients treated with AFINITOR or AFINITOR DISPERZ

SEGA volume should be evaluated approximately 3 months after commencing AFINITOR or AFINITOR DISPERZ therapy and periodically thereafter. In the phase II and phase III clinical studies, SEGA volume monitoring was performed at baseline, Month 3, Month 6 and every 6

months thereafter. The optimal schedule of monitoring and the optimal duration of AFINITOR therapy are unknown, but SEGA progressions were reported in 13 of the 111 patients approximately 8 to 56 months after initiation of AFINITOR therapy by independent central review in the phase III study. Six patients progressed while on AFINITOR remained on treatment as they were considered to be experiencing clinical benefit. No patient required surgical intervention for SEGA during the course of the study. Subsequent dose adjustments should take into consideration changes in SEGA volume, corresponding trough concentration and tolerability. Responses have been observed at trough concentrations as low as 2 ng/mL; as such, once acceptable efficacy has been achieved, additional dose increase is not necessary.

Special Populations and Conditions

Hepatic impairment:

Patients with SEGA associated with TSC, ≥ 18 years of age

- Mild hepatic impairment (Child-Pugh A) – 75% of the dose calculated based on BSA (rounded to the nearest strength)
- Moderate hepatic impairment (Child-Pugh B) – 50% of the dose calculated based on BSA (rounded to the nearest strength)
- Severe hepatic impairment (Child-Pugh C) – not recommended

Patients with seizures associated with TSC, ≥ 18 years of age

- Mild hepatic impairment (Child-Pugh A) – 75% of the dose calculated based on BSA (rounded to the nearest strength)
- Moderate hepatic impairment (Child-Pugh B) – 25% of the dose calculated based on BSA (rounded to the nearest strength)
- Severe hepatic impairment (Child-Pugh C) – not recommended

Patients < 18 years of age

AFINITOR and AFINITOR DISPERZ are not recommended for patients < 18 years of age with SEGA or seizures associated with TSC and concomitant hepatic impairment.

Paediatrics (< 18 years):

Dosing recommendation for paediatric patients with SEGA are consistent with those for the corresponding adult population.

Dosing recommendations for paediatric patients ≥ 6 years of age with seizures associated with TSC are consistent with those for the corresponding adult population. The recommended AFINITOR DISPERZ starting dose for patients < 6 year of age and patients ≥ 6 years of age is provided in Table 16.

AFINITOR and AFINITOR DISPERZ are not recommended for patients < 18 years of age with SEGA who have any degree of hepatic impairment. AFINITOR DISPERZ is not recommended for patients < 18 years of age with seizures associated with TSC who have any degree of hepatic impairment (see **Hepatic impairment** above).

Missed Dose

AFINITOR and AFINITOR DISPERZ can still be taken up to 6 hours after the time it is normally taken. After more than 6 hours, the dose should be skipped for that day. The next day, AFINITOR or AFINITOR DISPERZ should be taken at its usual time. Double doses should not be taken to make up for the one that was missed.

Administration

SEGA associated with TSC

AFINITOR

AFINITOR tablets should be swallowed whole with a glass of water. The tablets should not be chewed or crushed.

SEGA and/or seizures associated with TSC

AFINITOR DISPERZ

AFINITOR DISPERZ tablets for oral suspension should be administered as a suspension only and should not be swallowed whole, chewed, or crushed. The suspension can be prepared in an oral syringe or in a small drinking glass. Care should be taken to ensure the entire dose is administered.

Administer the suspension immediately after preparation. Discard the suspension if not administered within 60 minutes of preparation. Prepare the suspension in water only.

A complete and illustrated set of instructions for the tablet for oral suspension is provided in **Part III: CONSUMER INFORMATION**.

Using an oral syringe:

- Place the prescribed dose of AFINITOR DISPERZ into a 10 mL syringe. Do not exceed a total of 10 mg per syringe. If higher doses are required, prepare an additional syringe. Do not break or crush tablets.
- Draw approximately 5 mL of water and 4 mL of air into the syringe.
- Place the filled syringe into a container (tip up) for 3 minutes, until the AFINITOR DISPERZ tablets are in suspension.
- Gently invert the syringe 5 times immediately prior to administration.
- After administration of the prepared suspension, draw approximately 5 mL of water and 4 mL of air into the same syringe, and swirl the contents to suspend remaining particles. Administer the entire contents of the syringe.

Using a small drinking glass:

- Place the prescribed dose of AFINITOR DISPERZ into a small drinking glass (maximum size 100 mL) containing approximately 25 mL of water. Do not exceed a total of 10 mg of AFINITOR DISPERZ per glass. If higher doses are required, prepare an additional glass. Do not break or crush tablets.
- Allow 3 minutes for suspension to occur.
- Stir the contents gently with a spoon, immediately prior to drinking.
- After administration of the prepared suspension, add 25 mL of water and stir with the same spoon to re-suspend remaining particles. Administer the entire contents of the glass.

Switching dosage forms

The two dosage forms (AFINITOR and AFINITOR DISPERZ) are **not** interchangeable. Do not combine the two dosage forms to achieve the desired dose. Use one dosage form or the other.

When switching dosage forms, the dose should be adjusted to the closest milligram strength of the new dosage form and the everolimus trough concentration should be assessed approximately 2 weeks later (see **Therapeutic drug monitoring for patients treated for SEGA and/or seizures associated with TSC** above).

OVERDOSAGE

For management of suspected drug overdose, contact your regional poison control centre.

In animal studies, everolimus showed a low acute toxic potential. No lethality or severe toxicity was observed in either mice or rats given single oral doses of 2,000 mg/kg (limit test).

Reported experience with overdose in humans is very limited. Single doses of up to 70 mg have been given with acceptable acute tolerability.

There is no specific treatment for AFINITOR or AFINITOR DISPERZ overdose and general supportive care, including frequent monitoring of vital signs and close observation of the patient, is indicated.

ACTION AND CLINICAL PHARMACOLOGY

Mechanism of Action

Everolimus is an inhibitor targeting mTOR (mammalian target of rapamycin), or more specifically, mTORC1 (mammalian 'target of rapamycin' complex 1). mTOR is a key serine-threonine kinase playing a central role in the regulation of cell growth, proliferation and survival. The regulation of mTORC1 signalling is complex, being modulated by mitogens, growth factors, energy and nutrient availability. mTORC1 is an essential regulator of global protein synthesis downstream of the PI3K/AKT pathway, which is dysregulated in the majority of human cancers. Consistent with the central regulatory role of mTORC1, its inhibition by everolimus has been shown to reduce cell proliferation, glycolysis and angiogenesis in solid tumours *in vivo*, both through direct anti-tumour cell activity and inhibition of the tumour stromal compartment.

Activation of the mTOR pathway is a key adaptive change driving endocrine resistance in breast cancer. Various signal transduction pathways are activated to escape the effect of endocrine therapy. One pathway is the PI3K/Akt/mTOR pathway, which is constitutively activated in aromatase inhibitor (AI)-resistant and long-term oestrogen-deprived breast cancer cells. In *in vitro* models of breast cancer cells, resistance to AIs due to Akt activation can be reversed by co-administration with everolimus.

In tuberous sclerosis complex, a genetic disorder, inactivating mutations in either the TSC1 or the TSC2 gene lead to hamartoma formation throughout the body as well as seizures. In animal models of TSC, everolimus appears to exert inhibitory effects on phosphorylation of substrates of mTOR (see **DETAILED PHARMACOLOGY**).

Pharmacodynamics/Exposure response relationships

Exposure-response relationships: There was a moderate correlation between the decrease in the phosphorylation of 4E-BP1 (p4E-BP1) in tumour tissue and the average everolimus C_{min} at steady state in blood after daily administration of 5 or 10 mg everolimus. Further data suggest that the inhibition of phosphorylation of the S6 kinase is very sensitive to the mTOR inhibition by everolimus. Inhibition of phosphorylation of eIF-4G was complete at all C_{min} values after the 10 mg daily dose.

Cardiac Electrophysiology: Everolimus was studied in a randomised, placebo- and active-controlled, crossover ECG assessment study performed in 64 healthy subjects who received 20 mg and 50 mg single doses of everolimus. The maximum placebo-adjusted mean difference from placebo in the QTcF interval [$QTcF=QT/RR^{0.33}$] was 4.15 (90% CI 2.33; 5.97) ms in the 20 mg treatment arm and 4.26 (90% CI 2.45, 6.07) ms in the 50 mg treatment arm, both at the 12 hour time point. The effects of repeat dosing were not tested.

Pharmacokinetics

Absorption: After administration of AFINITOR to patients with advanced solid tumours, peak everolimus concentrations are reached 1 to 2 hours after administration of an oral dose of 5 to 70 mg everolimus under fasting conditions or with a light fat-free snack. C_{max} is dose-proportional with daily dosing between 5 and 10 mg. With single doses of 20 mg and higher, the increase in C_{max} is less than dose-proportional; however, AUC shows dose-proportionality over the 5 to 70 mg dose range. Steady-state was achieved within 2 weeks with the daily dosing regimen. There

was a significant correlation between $AUC_{0-\tau}$ and pre-dose trough concentration at steady-state on the daily regimen.

Table 17 Summary Statistics of Main Pharmacokinetic Parameters of Everolimus in the Pivotal Phase III Trial

	C_{max} (ng/mL)	t_{max} (h)	C_{min} (ng/mL)	$AUC_{0-\tau}$ (ng.h/mL)	CL/F (L/h)	CL/F (L/h/m ²)
Day 1 (n = 13)	68.1 ± 29.8	1 (1-2)	7.9 ± 3.4	455.0 ± 168.5	—	—
CV	(43.7%)		(43.3%)	(37.0%)		
Day 15 (n =12)	76.7 ± 39.3	1 (1-5)	19.8 ± 12.3	729.1 ± 262.7	15.4 ± 5.3	7.5 ± 2.3
CV	(51.2%)		(61.8%)	(36.0%)	(34.3%)	(30.1%)

Food effect: In healthy subjects, high fat meals reduced systemic exposure to AFINITOR 10 mg (as measured by AUC) by 22% and the peak blood concentration C_{max} by 54%. Light fat meals reduced AUC by 32% and C_{max} by 42%. Food, however, had no apparent effect on the elimination phase concentration-time profile.

Relative bioavailability of tablets for oral suspension: In comparative bioavailability studies, the C_{max} of everolimus associated with the tablet for oral suspension when administered as a suspension in water was lower than that of the intact everolimus tablets (C_{max} of the tablets for oral suspension was 64% to 80% of the intact everolimus tablets). In addition, the $AUC_{0-\infty}$ of the everolimus tablets for oral suspension was 86% to 91% that of intact everolimus tablets. Similarly, AUC_{0-72h} was 86 to 90 % that of the intact everolimus tablets. However, the predicted trough (C_{min}) concentrations of everolimus at steady-state after daily administration were similar for both formulations (see **Table 31 and Table 32, CLINICAL TRIALS, Comparative Bioavailability Studies**).

Distribution: The blood-to-plasma ratio of everolimus, which is concentration-dependent over the range of 5 to 5,000 ng/mL, is 17% to 73%. The amount of everolimus confined to the plasma is approximately 20% at blood concentrations observed in cancer patients given AFINITOR 10 mg/day. Plasma protein binding is approximately 74%, both in healthy subjects and in patients with moderate hepatic impairment.

Following intravenous administration in a rat model, everolimus was shown to cross the blood-brain barrier in a non-linear dose-dependent manner, suggesting saturation of an efflux pump at the blood-brain barrier. Brain penetration of everolimus has also been demonstrated in rats receiving oral doses of everolimus.

Biotransformation/Metabolism: Everolimus is a substrate of CYP3A4 and PgP. Following oral administration, it is the main circulating component in human blood. Six main metabolites of everolimus have been detected in human blood, including three monohydroxylated metabolites, two hydrolytic ring-opened products, and a phosphatidylcholine conjugate of everolimus. These metabolites were also identified in animal species used in toxicity studies, and showed approximately 100-times less activity than everolimus itself. Hence, the parent substance is considered to contribute the majority of the overall pharmacological activity of everolimus.

Elimination: No specific elimination studies have been undertaken in cancer patients; however, data are available from the transplantation setting. Following the administration of a single dose of radio-labelled everolimus in conjunction with cyclosporine, 80% of the radioactivity was recovered from the faeces, while 5% was excreted in the urine over 10 days. The parent substance was not detected in urine or faeces.

Special Populations and Conditions

Paediatrics:

In patients who have SEGA associated with TSC receiving AFINITOR, the geometric mean C_{min} values normalized to mg/m^2 dose in patients aged < 10 years and 10 - 18 years were lower by 54% and 40% respectively, than those observed in adults (> 18 years of age), suggesting that everolimus clearance normalized to body surface area was higher in paediatric patients as compared to adults. Dosing in this population should be guided by Therapeutic Drug Monitoring (see **DOSAGE AND ADMINISTRATION, SEGA associated with Tuberous Sclerosis Complex, Therapeutic drug monitoring for patients treated for SEGA**).

In patients with seizures associated with TSC receiving AFINITOR DISPERZ, a trend was observed toward lower C_{min} normalized to dose (as mg/m^2) in younger patients. Median C_{min} normalized to mg/m^2 dose was lower for the younger age groups (<6 years), indicating that everolimus clearance (normalized to body surface area) was higher in younger patients (see **DOSAGE AND ADMINISTRATION**, Table 16).

Geriatrics: In a population pharmacokinetic evaluation in cancer patients, no significant influence of age (27 to 85 years) on oral clearance (CL/F: range 4.8 to 54.5 litres/hour) of everolimus was detected.

Gender: Analyses of efficacy and safety data in male and female subgroups suggest that no dose adjustments are necessary based on patient gender.

Race: Oral clearance (CL/F) is similar in Japanese and Caucasian cancer patients with similar liver functions. Based on analysis of population pharmacokinetics, oral clearance (CL/F) is on average 20% higher in black transplant patients.

Hepatic Impairment: The influence of hepatic impairment on the pharmacokinetics of AFINITOR was assessed in two independent single oral dose studies in adult volunteers. One study evaluated the pharmacokinetics of everolimus in 8 volunteers with moderate hepatic impairment (Child-Pugh B) and 8 volunteers with normal hepatic function. Compared to normal volunteers, there was a 2.2-fold increase in exposure (AUC_{0-inf}) for subjects with moderate hepatic impairment. A second study evaluated the pharmacokinetics of AFINITOR in 7 volunteers with mild hepatic impairment (Child-Pugh A), 8 volunteers with moderate hepatic impairment (Child-Pugh B), 6 volunteers with severe hepatic impairment (Child-Pugh C) and 13 volunteers with normal hepatic function. Compared to normal volunteers, there was a 1.6-fold, 3.3-fold and 3.6-fold increase in exposure (AUC_{0-inf}) for volunteers with mild, moderate and severe hepatic impairment, respectively. Simulations of multiple dose pharmacokinetics support

the dosing recommendations in hepatic impaired patients based on their Child-Pugh status. Dose adjustment is recommended for patients with hepatic impairment. Dosing recommendations are based on the combined results of the two studies (see **WARNINGS AND PRECAUTIONS** and **DOSAGE AND ADMINISTRATION**).

Renal Impairment: In a population pharmacokinetic analysis of 170 patients with advanced cancer, no significant influence of creatinine clearance (25 to 178 mL/min) was detected on CL/F of everolimus. Post-transplant renal impairment (creatinine clearance range 11 to 107 mL/min) did not affect the pharmacokinetics of everolimus in transplant patients.

STORAGE AND STABILITY

Store at room temperature (15 – 30 °C). Store in the original package to protect from light and moisture.

Keep in a safe place out of the reach of children and pets.

SPECIAL HANDLING INSTRUCTIONS

The extent of absorption of everolimus through topical exposure is not known. Therefore, caregivers are advised to avoid contact with suspensions of AFINITOR DISPERZ. Wash hands thoroughly before and after preparation of the suspension.

DOSAGE FORMS, COMPOSITION AND PACKAGING

Tablets

AFINITOR (everolimus) tablets are elongated, white to slightly yellow in colour with a bevelled edge and no score. AFINITOR tablets are available in four strengths: 2.5 mg, 5 mg, 7.5 mg and 10 mg.

2.5 mg:

The tablets are engraved with “LCL” on one side and “NVR” on the other.

5 mg:

The tablets are engraved with “5” on one side and “NVR” on the other.

7.5 mg:

The tablets are engraved with “7P5” on one side and “NVR” on the other.

10 mg:

The tablets are engraved with “UHE” on one side and “NVR” on the other.

Non-medicinal Ingredients

Butylated hydroxytoluene, crospovidone, hypromellose, lactose anhydrous, lactose monohydrate, magnesium stearate.

AFINITOR 2.5 mg, 5 mg and 10 mg tablets are supplied in blister packs (10 blisters/card, 3 cards/carton).

AFINITOR 7.5 mg are supplied in blister packs (7 blisters/card, 4 cards/carton).

Tablets for oral suspension

AFINITOR DISPERZ tablets for oral suspension are round, flat, white to slightly yellowish in colour with a bevelled edge and no score. AFINITOR DISPERZ tablets for oral suspension are available in three strengths: 2 mg, 3 mg and 5 mg.

2 mg:

The tablets are engraved with “D2” on one side and “NVR” on the other.

3 mg:

The tablets are engraved with “D3” on one side and “NVR” on the other.

5 mg:

The tablets are engraved with “D5” on one side and “NVR” on the other.

Non-medicinal Ingredients

Butylated hydroxytoluene, cellulose microcrystalline, crospovidone, hypromellose, lactose monohydrate, magnesium stearate, mannitol and silica colloidal anhydrous.

AFINITOR DISPERZ 2 mg, 3 mg and 5 mg tablets for oral suspension are supplied in blister packs (10 blisters/card, 3 cards/carton).

PART II: SCIENTIFIC INFORMATION

PHARMACEUTICAL INFORMATION

Drug Substance

Common name: Everolimus

Chemical name: (1R,9S,12S,15R,16E,18R,19R,21R,23S,24E,26E,28E,30S,32S,35R)-1,18-Dihydroxy-12-[(1R)-2-[(1S, 3R, 4R)-4-(2-hydroxyethoxy)-3-methoxycyclohexyl]-1-methylethyl]-19,30-dimethoxy-15,17,21,23,29,35-hexamethyl-11,36-dioxo-4-azatricyclo [30.3.1.0^{4,9}]-hexatriaconta-16,24,26,28-tetraene-2,3,10,14,20-pentaone

Molecular formula: C₅₃H₈₃NO₁₄

Molecular mass: 958.2

Structural formula:

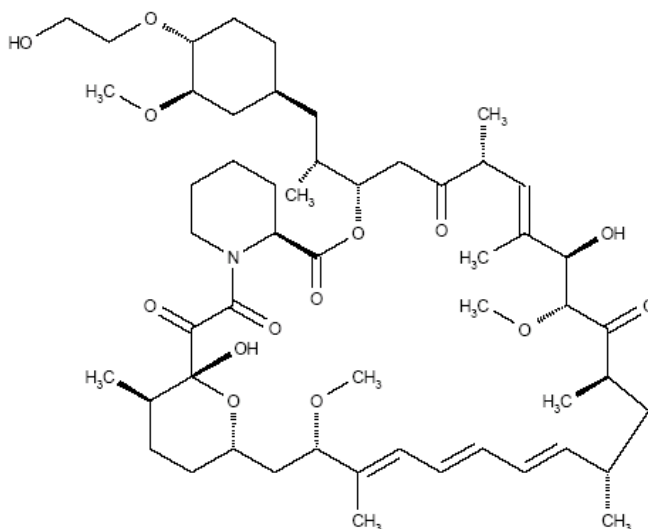

Physicochemical properties

Physical description: White to faintly white powder

Solubility: The drug substance is practically insoluble in water, but it is soluble in organic solvents.

pH: Because the solubility in water is very low (<0.01 %) the pH of an aqueous solution was not determined. The pH value of 0.1 %

suspension of several batches in 1 % aqueous solution of KNO₃ were measured and the values lie in the range 4-6.

pKa:	No pKa value can be determined (neutral compound).
Partition Coefficient:	Because of the low solubility of everolimus stabilized with BHT in water and in aqueous buffers, the partition coefficient could not be determined.
Melting Point:	Not applicable since the drug substance is amorphous.

CLINICAL TRIALS

Safety and Efficacy Studies

Hormone Receptor-Positive, HER2-Negative Advanced Breast Cancer

Study Y2301 (BOLERO-2)

A randomized, double-blind, multicentre, international phase III study of AFINITOR plus exemestane versus placebo plus exemestane was conducted in postmenopausal women with oestrogen receptor-positive, HER 2-neu/non-amplified advanced breast cancer with recurrence or progression following prior therapy with letrozole or anastrozole.

Refractory disease to NSAIs was defined as:

- Recurrence while on or within 12 months of the end of adjuvant treatment with letrozole or anastrozole
- or
- Progression while on or within 1 month of the end of letrozole or anastrozole treatment for locally advanced or metastatic breast cancer

Except for the prior use of exemestane and mTOR inhibitors, there were no restrictions as to the last anticancer treatment prior to randomization. Patients were permitted to have received 0-1 prior lines of chemotherapy in the advanced disease setting. Documented recurrence or progression on last therapy prior to randomization was required, but letrozole or anastrozole did not have to be the last line of therapy.

Patients were randomized in a 2:1 ratio to receive either AFINITOR (10 mg daily) or matching placebo in addition to open-label exemestane (25 mg daily). Randomization was stratified by documented sensitivity to prior hormonal therapy (yes vs. no) and by the presence of visceral metastasis (yes vs. no). Sensitivity to prior hormonal therapy was defined as either (1) documented clinical benefit (complete response [CR], partial response [PR], stable disease \geq 24 weeks) to at least one prior hormonal therapy in the advanced setting or (2) at least 24 months of adjuvant hormonal therapy prior to recurrence.

The primary endpoint for the trial was progression-free survival (PFS) evaluated by Response Evaluation Criteria in Solid Tumours (RECIST 1.0), based on the investigator's (local radiology) assessment. Supportive PFS analyses were based on a blinded, independent central radiology review.

Overall survival (OS) was the key secondary endpoint. Other secondary endpoints included Overall Response Rate (ORR), Clinical Benefit Rate (CBR), Safety, change in Quality of Life (QOL) [EORTC QLQ-C30] and time to ECOG PS deterioration.

A total of 724 patients were randomized to the combination AFINITOR plus exemestane (n = 485) or placebo plus exemestane (n = 239). The two treatment groups were generally balanced with respect to baseline demographics, tumour burden, disease characteristics and history of prior anti-neoplastic therapies (see Table 18). Overall, 84% of patients were considered to be sensitive to prior endocrine therapy. The median age of patients was 61 years (range 28 to 93 years). Patients in the placebo plus exemestane arm did not cross-over to AFINITOR at the time of progression.

Table 18 Demographic and Disease Characteristics (Hormone Receptor-Positive, HER2-Negative Advanced Breast Cancer)

Demographic or disease characteristic	AFINITOR plus exemestane N=485 n (%)	Placebo plus exemestane N=239 n (%)	All patients N=724 n (%)
Age category (years) (n [%])			
< 65 years	290 (59.8)	159 (66.5)	449 (62.0)
≥ 65 years to <75 years	123 (25.4)	58 (24.3)	181 (25.0)
≥ 75 years	72 (14.8)	22 (9.2)	94 (13.0)
Race			
Caucasian	361 (74.4)	186 (77.8)	547 (75.6)
Asian	98 (20.2)	45 (18.8)	143 (19.8)
Black	13 (2.7)	3 (1.3)	16 (2.2)
Other	13 (2.7)	5 (2.1)	18 (2.5)
Current disease status			
Metastatic	483 (99.6)	239 (100.0)	722 (99.7)
Locally advanced	2 (0.4)	0	2 (0.3)
Metastatic site of cancer			
Bone	370 (76.3)	184 (77.0)	554 (76.5)
Visceral (excluding CNS)	283 (58.4)	143 (59.8)	426 (58.8)
CNS	6 (1.2)	0	6 (0.8)
Other	245 (50.5)	137 (57.3)	382 (52.8)
ECOG performance status			
0	293 (60.4)	142 (59.4)	435 (60.1)
1	174 (35.9)	84 (35.1)	258 (35.6)
2	9 (1.9)	7 (2.9)	16 (2.2)
Missing	9 (1.9)	6 (2.5)	15 (2.1)
Prior anti-neoplastic therapy			

Demographic or disease characteristic	AFINITOR plus exemestane N=485 n (%)	Placebo plus exemestane N=239 n (%)	All patients N=724 n (%)
Any non-steroidal aromatase inhibitor (NSAI)	485 (100)	239 (100)	724 (100)
Prior hormonal therapy other than NSAI	281 (57.9)	146 (61.1)	427 (59.0)
Chemotherapy	337 (69.5)	156 (65.3)	493 (68.1)
Neoadjuvant /adjuvant setting	211 (43.5)	95 (39.7)	306 (42.3)
Advanced setting (one line)	125 (25.8)	58 (24.3)	183 (25.3)
Other therapy	38 (7.8)	13 (5.4)	51 (7.0)

At baseline, 218 patients (45.2%) to be randomized to AFINITOR plus exemestane and 130 patients (54.6%) to be randomized to placebo plus exemestane were taking a bisphosphonate. At update, 251 patients (52.1%) in the AFINITOR plus exemestane arm and 140 patients (58.8%) in the placebo plus exemestane arm were taking a bisphosphonate.

The trial met its primary PFS endpoint at a pre-planned interim efficacy analysis (median study follow-up of 7.6 months and documentation of 68% of targeted PFS events). A statistically significant clinical benefit of AFINITOR plus exemestane over placebo plus exemestane was demonstrated by a 2.4-fold prolongation in median PFS (median: 6.93 months versus 2.83 months), resulting in a 57% risk reduction of progression or death (PFS HR 0.43; 95% CI: 0.35, 0.54); one-sided log-rank test p-value <0.0001 per local investigator assessment.

Subsequently, the trial remained blinded to investigators and patients to permit OS data to mature. Updated efficacy results (excluding OS) with an additional 5 months of follow-up (overall median follow-up of 12.5 months and documentation of 87% of targeted PFS events) demonstrated a significant clinical benefit of AFINITOR plus exemestane over placebo plus exemestane by a 2.3-fold prolongation in median PFS (median: 7.36 months versus 3.19 months), resulting in a 56 % risk reduction of progression or death (PFS HR 0.44; 95% CI: 0.36, 0.53); one-sided log-rank test p-value <0.0001 per local investigator assessment (see Table 19 and Figure 1).

The analysis of PFS based on independent central radiological assessment was supportive (see Table 19).

No clinically or statistically significant differences were observed between the two treatment arms in terms of time to deterioration of ECOG PS (≥ 1 point) and median times to deterioration ($\geq 5\%$) of QLQ-C30 domain scores.

OS data were not mature at the time of a second interim analysis (additional 8 months of follow-up) based on 182 observed deaths (representing 23% and 29% of patient-deaths reported in the AFINITOR plus exemestane arm and placebo plus exemestane arm, respectively). No statistically significant treatment-related difference in OS was noted [HR=0.77 (95% CI: 0.57,

1.04)]. The final OS analysis is planned at 398 deaths.

Table 19 Efficacy Results at a Median Follow-up of 12.5 Months (Hormone Receptor-Positive, HER2-Negative Advanced Breast Cancer)

Analysis	AFINITOR + exemestane N=485	Placebo + exemestane N=239	Hazard Ratio (95%CI)	p-value
Median progression-free survival (months, 95% CI)				
Investigator radiological review	7.36 (6.93 to 8.48)	3.19 (2.76 to 4.14)	0.44 (0.36 to 0.53)	<0.0001
Independent radiological review	11.01 (9.56 to NA)	4.11 (2.83 to 5.55)	0.36 (0.28 to 0.45)	<0.0001
Best overall response (% , 95% CI)				
Objective response rate [Complete response (CR) or Partial response (PR)]	12% (7.0 to 12.4)	1.3% (0.3 to 3.6)	-	<0.0001 ^a
Clinical benefit rate (CR or PR or stable disease ≥ 24 weeks)	50.5% (46.0 to 55.1)	25.5% (20.1 to 31.5)	-	<0.0001 ^a

^a p-value is obtained from the exact Cochran-Mantel-Haenszel test using a stratified version of the Cochran-Armitage permutation test

Figure 1 Kaplan-Meier Progression-free Survival Curves at a Median Follow-up of 12.5 Months

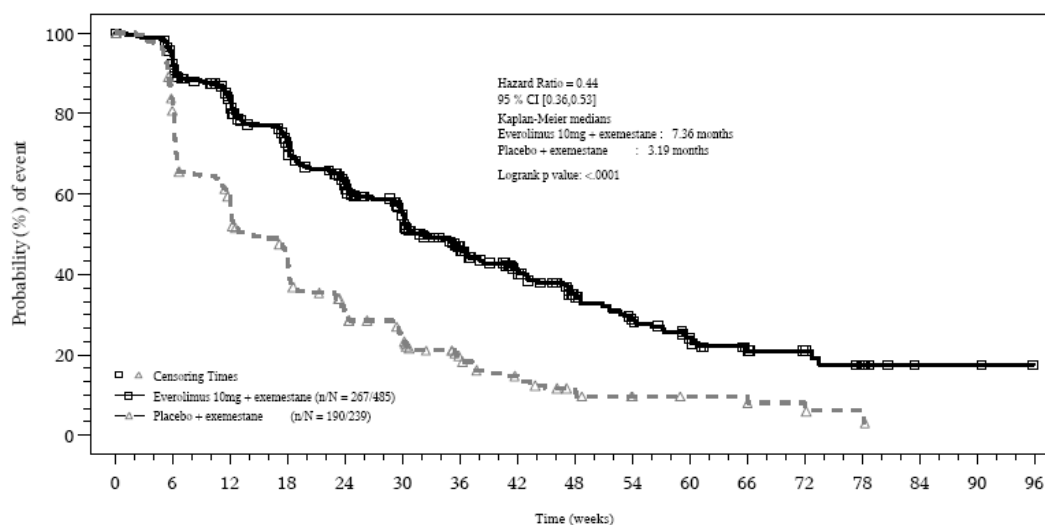

Number of Patients still at Risk																	
Time(weeks)	0	6	12	18	24	30	36	42	48	54	60	66	72	78	84	90	96
Everolimus	485	436	365	303	246	188	136	96	64	45	34	21	13	9	2	2	0
Placebo	239	190	131	95	63	45	29	19	12	8	6	6	4	2	0	0	0

Planned exploratory subgroup analyses of PFS demonstrated a positive treatment effect for AFINITOR plus exemestane across all subgroups analysed (see Figure 2).

Figure 2 Forest plot of PFS as per investigator by subgroup

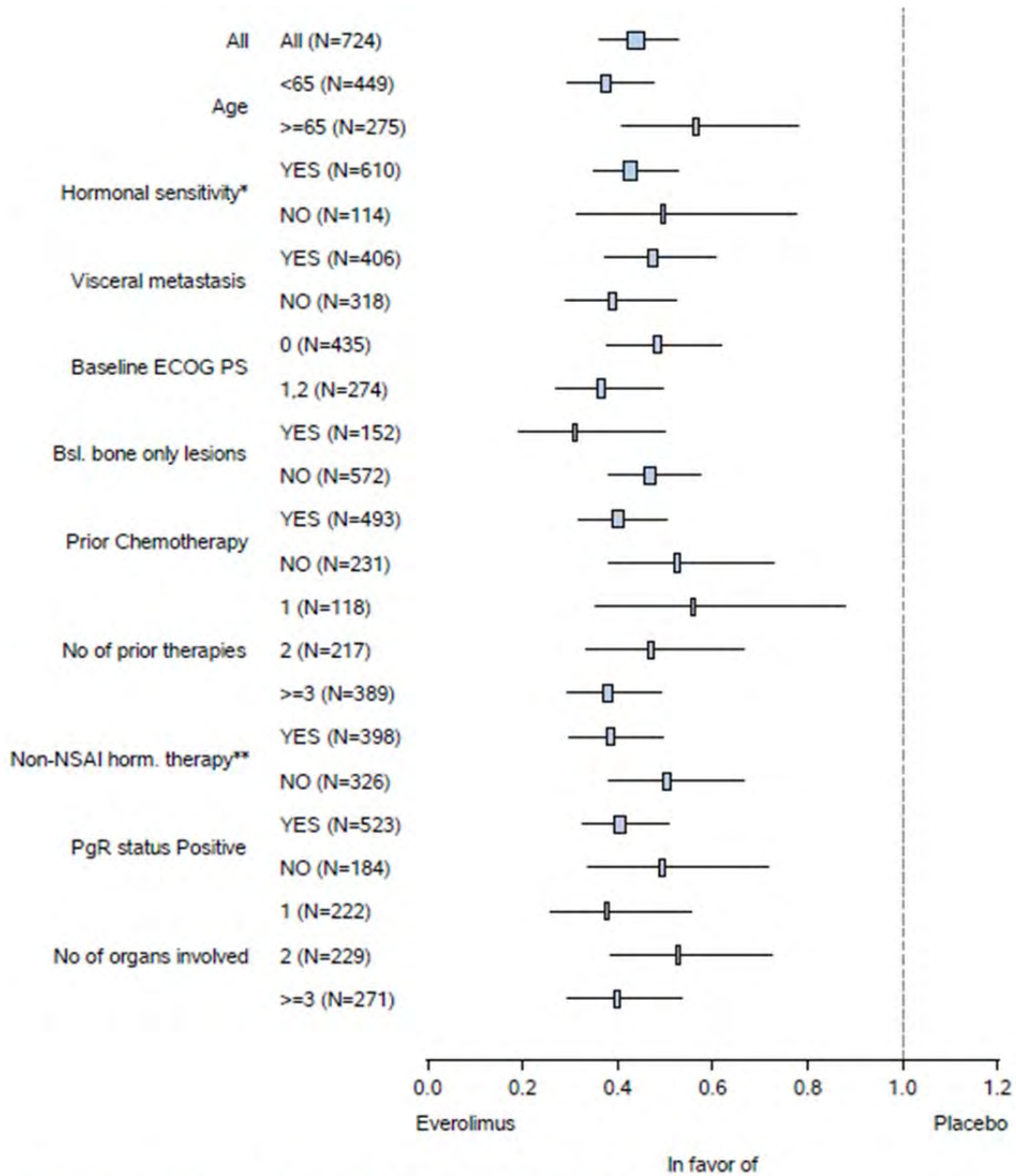

Hazard ratio was obtained using unstratified Cox proportional hazard model.

* sensitivity to prior hormonal therapy

** anti-estrogens, LHRH analogs and progestins

Pancreatic Neuroendocrine Tumours (PNET)

Study C2324 (RADIANT-3)

A randomized, double-blind, multi-centre phase III study of AFINITOR plus best supportive care (BSC) versus placebo plus BSC was conducted in patients with locally advanced or metastatic pancreatic neuroendocrine tumours (PNET) and disease progression within the prior 12 months. Patients were stratified by prior cytotoxic chemotherapy (yes/no) and by WHO performance status (0 vs. 1 and 2). Treatment with somatostatin analogues was allowed as part of BSC.

The primary endpoint for the trial was PFS evaluated by RECIST (Response Evaluation Criteria in Solid Tumours, version 1.0) as per investigator radiology review. After documented radiological progression, patients could be unblinded by the investigator; those randomized to placebo were then able to receive open-label AFINITOR. Crossover from placebo to open-label AFINITOR occurred in 73% (148/203) of patients.

Secondary endpoints include safety, objective response rate (ORR) (complete response [CR] or partial response [PR]) and overall survival.

Patients were randomized 1:1 to receive either AFINITOR 10mg/day (n=207) or placebo (n=203). Demographics were well balanced (median age 58 years, 55% male, 79% Caucasian).

Table 20 Demographic and Disease Characteristics (PNET)

Demographic or disease characteristic	AFINITOR N=207 n (%)	Placebo N=203 n (%)	Total N=410 N (%)
Age (years)			
Mean (standard deviation)	57.1 (12.2)	56.2 (11.4)	56.5 (11.8)
Median	58.0	57.0	58.0
Range	23 - 87	20 - 82	20 - 87
Age group (years) (n [%])			
< 65 years	146 (70.5)	153 (75.4)	299 (72.9)
≥ 65 years	61 (29.5)	50 (24.6)	111 (27.1)
Gender			
Male	110 (53.1)	117 (57.6)	227 (55.4)
Female	97 (46.9)	86 (42.4)	183 (44.6)
Race			
Caucasian	146 (75.4)	166 (81.8)	322 (78.5)
Asian	40 (19.3)	34 (16.7)	74 (18.0)
Black	9 (4.3)	2 (1.0)	11 (2.7)
Other	2 (1.0)	1 (0.5)	3 (0.7)
Histologic grade			
Well differentiated	170 (82.1)	171 (84.2)	341 (83.2)
Moderately differentiated	35 (16.9)	30 (14.8)	65 (15.9)
Unknown	2 (1.0)	2 (1.0)	4 (1.0)

Demographic or disease characteristic	AFINITOR N=207 n (%)	Placebo N=203 n (%)	Total N=410 N (%)
WHO performance status			
0	139 (67.1)	133 (65.5)	272 (66.3)
1	62 (30.0)	64 (31.5)	126 (30.7)
2	6 (2.9)	6 (2.9)	12 (2.9)
Prior long-acting somatostatin analogue therapy	101 (48.8)	102 (50.2)	203 (49.5)

The trial demonstrated a statistically significant improvement in PFS (median 11.0 months versus 4.6 months), resulting in a 65% risk reduction in investigator-determined PFS (HR 0.35; 95% CI: 0.27, 0.45; p<0.0001) (see Table 21 and Figure 3). PFS improvement was observed across all patient subgroups, irrespective of prior somatostatin analogue use. The PFS results by investigator radiological review, central radiological review and adjudicated radiological review are shown below in Table 21.

Table 21 Progression Free Survival Results (PNET)

Analysis	N 410	AFINITOR N=207	Placebo N=203	Hazard Ratio (95%CI)	p-value^b
		Median progression-free survival (months) (95% CI)			
Investigator radiological review		11.0 (8.4 to 13.9)	4.60 (3.1 to 5.4)	0.35 (0.27 to 0.45)	<0.0001
Central radiological review		13.7 (11.2 to 18.8)	5.7 (5.4 to 8.3)	0.38 (0.28 to 0.51)	<0.001
Independent radiological review ^a		11.40 [10.84, 14.75]	5.39 [4.34, 5.55]	0.34 [0.26, 0.44]	<0.0001

^a Includes adjudication for discrepant assessments between investigator radiological review and central radiological review

^b one-sided p-value from a stratified log-rank test

Figure 3 Kaplan-Meier Investigator-Determined Progression-free Survival Curves

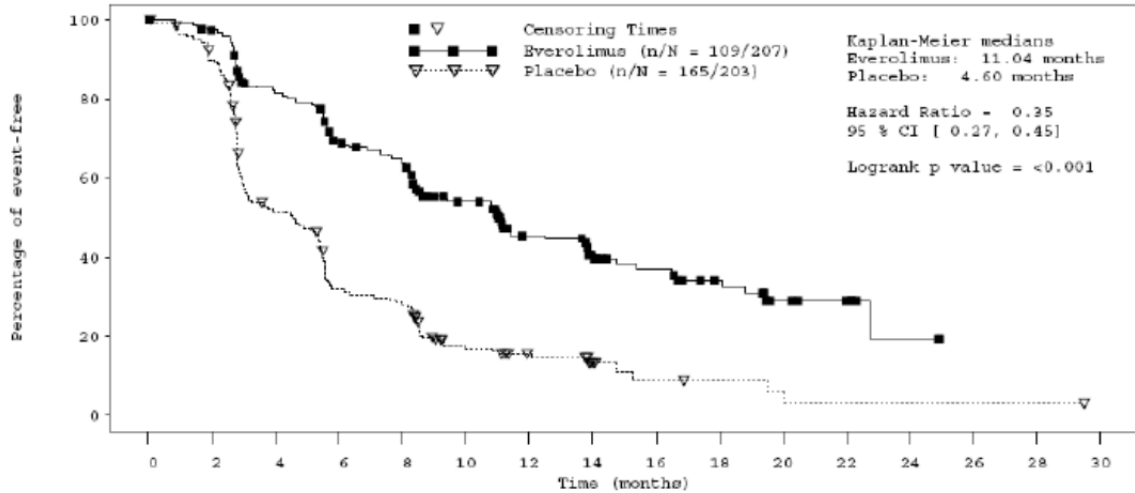

No. of patients still at risk																
Time (months)	0	2	4	6	8	10	12	14	16	18	20	22	24	26	28	30
Everolimus	207	189	152	126	114	80	49	36	28	21	10	6	2	0	0	0
Placebo	203	177	98	59	52	24	16	7	4	3	2	1	1	1	1	0

The objective response rate per investigator assessment was 4.8% for the AFINITOR arm vs. 2% for the placebo arm. Tumour reduction is also evident from the corresponding waterfall plot (Figure 4). Results indicate that 64.4% of patients in the everolimus arm experienced tumour shrinkage versus 20.6% for placebo.

Figure 4 Tumour shrinkage: best percentage change from baseline in sum of longest diameters as per investigator assessment

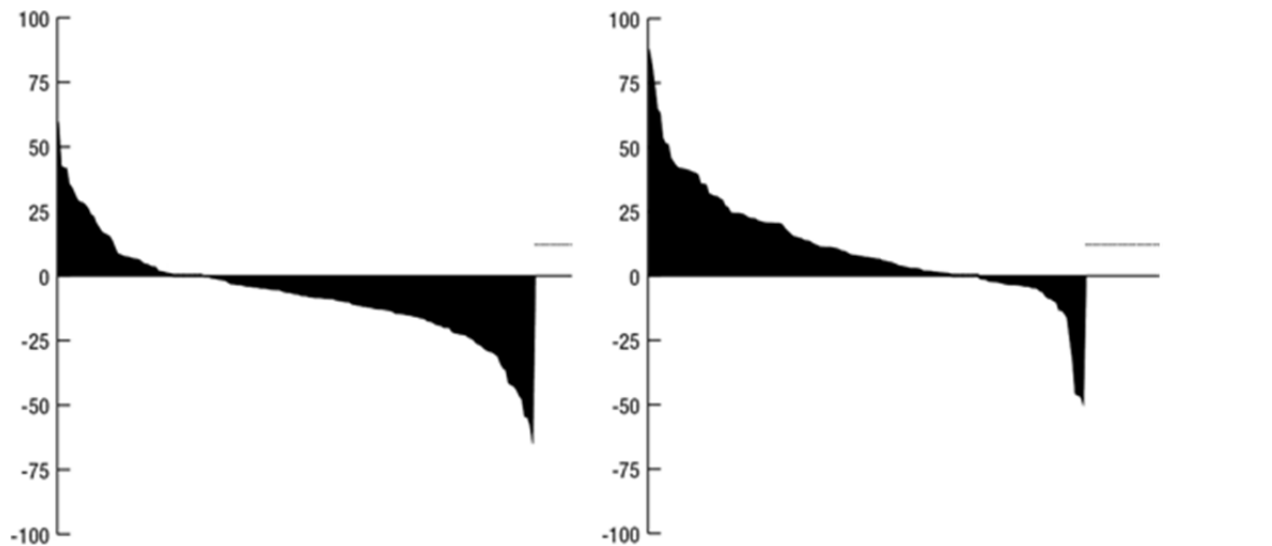

	Everolimus n (%)	Placebo n (%)
Decrease in best percentage change from baseline	123 (64.4%)	39 (20.6%)
Zero change in best percentage change from baseline	11 (5.8%)	10 (5.3%)
Increase in best percentage change from baseline	43 (22.5%)	112 (59.3%)
% Change in target lesion available but contradicted by overall lesion response = PD*	14 (7.3%)	28 (14.8%)

* Patients for whom the best % change in target lesions was either unavailable or was contradicted by overall lesion response of “unknown” were excluded from this analysis. Percentages were derived using the remaining number of evaluable patients (n) as the denominator.

The overall survival results are not yet mature and no statistically significant treatment-related difference in OS was noted [HR=0.99 (95% CI: 0.68 to 1.43)]. Crossover of > 72% of patients from placebo to open label AFINITOR following disease progression likely confounded the detection of any treatment related difference in OS.

Advanced, Non-Functional Neuroendocrine Tumours of Gastrointestinal or Lung Origin

Study T2302 (RADIANT-4)

A randomized, double-blind, multi-center study of AFINITOR plus best supportive care (BSC) versus placebo plus best supportive care was conducted in patients with unresectable, locally advanced or metastatic neuroendocrine tumours (NET) of gastrointestinal or lung origin without a history of and no active symptoms related to carcinoid syndrome. Patients enrolled in Study T2302 had well-differentiated (low or intermediate grade) histology and evidence of disease progression within 6 months prior to randomization. Randomization was stratified by prior somatostatin analog (SSA) use, tumour origin and WHO performance status. Best supportive care excluded the use of anti-tumour therapies such as SSAs.

The primary endpoint for the study was progression-free survival (PFS) evaluated by Response Evaluation Criteria in Solid Tumours (modified RECIST version 1.0) based on independent radiological assessment. Supportive PFS analysis was based on local investigator review.

Secondary endpoints included overall survival (OS), Overall Response Rate (ORR), Safety, change in Quality of Life (QoL) via FACT-G and time to WHO PS deterioration.

A total of 302 patients were randomised in a 2:1 ratio to receive either AFINITOR (10 mg daily) (n = 205) or placebo (n = 97). The two treatment groups were generally balanced with respect to the baseline demographics, disease characteristics and history of prior somatostatin analog (SSA) use. The median duration of blinded treatment was 40.4 weeks for patients receiving AFINITOR and 19.6 weeks for those receiving placebo. Patients in the placebo arm did not cross-over to everolimus at the time of progression.

Table 22 Demographic and Disease Characteristics (GI or lung NET)

Demographic variable	AFINITOR N=205 n (%)	Placebo N=97 n (%)	Total N=302 n (%)
Age (years)			
Median (min-max)	65 (22 – 86)	60 (24 – 83)	63 (22 – 86)
Age category (years) – n (%)			
<65	100 (48.8)	59 (60.8)	159 (52.6)
≥ 65	105 (51.2)	38 (39.2)	143 (47.4)
Gender – n (%)			
Male	89 (43.4)	53 (54.6)	142 (47.0)
Female	116 (56.6)	44 (45.4)	160 (53.0)

Demographic variable	AFINITOR N=205 n (%)	Placebo N=97 n (%)	Total N=302 n (%)
WHO performance status – n (%)			
0	149 (72.7)	73 (75.3)	222 (73.5)
1	55 (26.8)	24 (24.7)	79 (26.2)
2	1 (0.5)	0	1 (0.3)
Primary tumour site			
Lung	63 (30.7)	27 (27.8)	90 (29.8)
Ileum	47 (22.9)	24 (24.7)	71 (23.5)
Rectum	25 (12.2)	15 (15.5)	40 (13.2)
CUP	23 (11.2)	13 (13.4)	36 (11.9)
Jejunum	16 (7.8)	6 (6.2)	22 (7.3)
Stomach	7 (3.4)	4 (4.1)	11 (3.6)
Duodenum	8 (3.9)	2 (2.1)	10 (3.3)
Colon	5 (2.4)	3 (3.1)	8 (2.6)
Other	6 (2.9)	2 (2.1)	8 (2.6)
Caecum	4 (2.0)	1 (1.0)	5 (1.7)
Appendix	1 (0.5)	0	1 (0.3)
Tumour Grade			
Grade 1	129 (62.9)	65 (67.0)	194 (64.2)
Grade 2	75 (36.6)	32 (33.0)	107 (35.4)
Time from initial diagnosis to randomization			
≤6 months	26 (12.7)	12 (12.4)	38 (12.6)
>6 months - ≤12 months	37 (18.0)	13 (13.4)	50 (16.6)
>12 months - ≤18 months	14 (6.8)	12 (12.4)	26 (8.6)
>18 months - ≤24 months	12 (5.9)	9 (9.3)	21 (7.0)
>24 months - ≤36 months	29 (14.1)	13 (13.4)	42 (13.9)
>36 months	87 (42.4)	38 (39.2)	125 (41.4)
Previous treatments			
Any prior antineoplastic therapy ¹	159 (77.6)	82 (84.5)	241 (79.8)
Any prior radiotherapy	44 (21.5)	19 (19.6)	63 (20.9)
Any prior surgery	121 (59.0)	70 (72.2)	191 (63.2)
Any loco-regional therapy	23 (11.2)	10 (10.3)	33 (10.9)
Any prior medications	63 (30.7)	29 (29.9)	92 (30.5)
Any prior chemotherapy	54 (26.3)	23 (23.7)	77 (25.5)
Any prior hormonal therapy	1 (0.5)	1 (1.0)	2 (0.7)
Any prior immunotherapy	7 (3.4)	5 (5.2)	12 (4.0)
Any prior targeted therapy	2 (1.0)	0	2 (0.7)
Any prior other therapy	2 (1.0)	4 (4.1)	6 (2.0)
Prior SSA treatment			
Yes	109 (53.2)	54 (55.7)	163 (54.0)
Disease stage			
I	0	1 (1.0)	1 (0.3)
II	2 (1.0)	3 (3.1)	5 (1.7)
III	7 (3.4)	3 (3.1)	10 (3.3)
IV	196 (95.6)	90 (92.8)	286 (94.7)
Disease sites			
Liver	163 (79.5)	76 (78.4)	239 (79.1)
Lymph node/Lymphatic system	85 (41.5)	45 (46.4)	130 (43.0)
Lung	45 (22.0)	20 (20.6)	65 (21.5)
Bone	42 (20.5)	15 (15.5)	57 (18.9)
Peritoneum	25 (12.2)	8 (8.2)	33 (10.9)
Liver tumour burden			
0%	34 (16.6)	14 (14.4)	48 (15.9)

Demographic variable	AFINITOR N=205 n (%)	Placebo N=97 n (%)	Total N=302 n (%)
>0-10%	119 (58.0)	61 (62.9)	180 (59.6)
>10-25%	29 (14.1)	8 (8.2)	37 (12.3)
>25-50%	9 (4.4)	4 (4.1)	13 (4.3)
>50%	12 (5.9)	10 (10.3)	22 (7.3)
Unknown	2 (1.0)	0	2 (0.7)

¹Any prior antineoplastic therapy includes patients who have had prior medication (other than somatostatin analog), radiotherapy or surgery.

The efficacy results were obtained from the final analysis of PFS after 178 PFS events were observed per independent radiological review.

The study demonstrated a statistically significant clinical benefit of everolimus over placebo by a 52% risk reduction of progression or death (HR 0.48; 95% CI: 0.35, 0.67; one-sided stratified log-rank test p-value <0.001) per independent assessment (see Table 23 and Figure 5). The analysis of PFS based on local investigator assessment was supportive.

Table 23 RADIANT-4 – Progression Free Survival results

Analysis	N	AFINITOR N=205	Placebo N=97	Hazard Ratio ^a (95%CI)	p-value ^b
	302	Median progression-free survival (months) (95% CI)			
Independent radiological review		11.0 (9.2 to 13.3)	3.9 (3.6 to 7.4)	0.48 (0.35 to 0.67)	<0.001
Investigator radiological review		14.0 (11.2 to 17.7)	5.5 (3.7 to 7.4)	0.39 (0.28 to 0.54)	<0.001

^aHazard ratio from a stratified Cox model

^bOne-sided p-value from a stratified log-rank test

Figure 5 RADIANT-4 – Kaplan-Meier progression-free survival curves (independent radiological review)

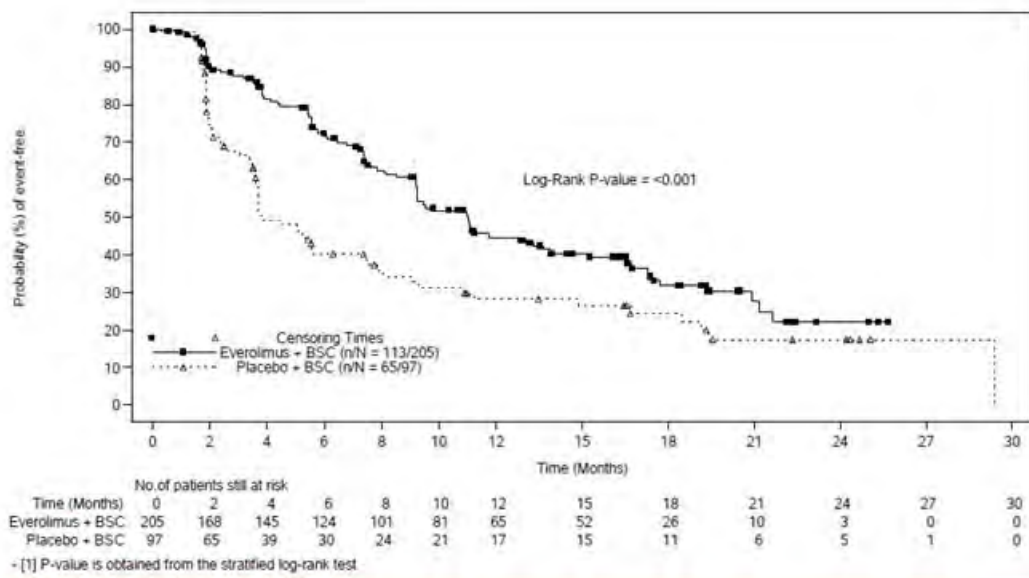

The overall PFS benefit favored AFINITOR across demographic and prognostic stratification subgroups (See Figure 6). Stratum A (appendix, cecum, jejunum, ileum, duodenum, and carcinoma of unknown primary (CUP)) corresponds to better prognosis and that stratum B (lung, stomach, rectum, and colon (with the exception of cecum)) has worse prognosis. In an exploratory subgroup analysis of PFS for sites of tumour origin, a positive treatment effect has been observed in all subgroups with the exception of the subgroup of patients with ileum as primary site of tumour origin (Ileum: HR=1.22 [95% CI: 0.56 to 2.65]). (See Figure 7).

Figure 6 Forest plot of hazard ratio for PFS by subgroup based on stratification factors (independent radiological review)

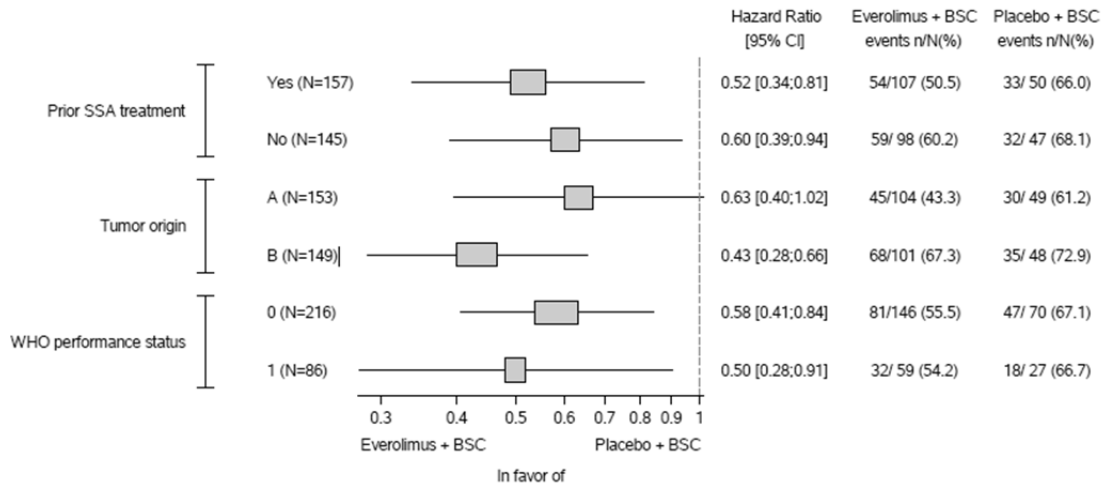

- Hazard ratio is obtained from unstratified Cox model
- The somatostatin analogs (SSA) pretreated stratum is defined as patients who had continuously received SSA for >=12 weeks any time prior to study inclusion.
- The tumor origin stratum is A for appendix, caecum, jejunum, ileum, duodenum and carcinoma of unknown primary (CUP).
- The tumor origin stratum is B for lung, stomach, rectum, and colon except caecum.
- Stratification factors are as per IRT.

Figure 7 Forest plot of stratified hazard ratio for PFS treatment effect for patient subgroups (independent radiological review)

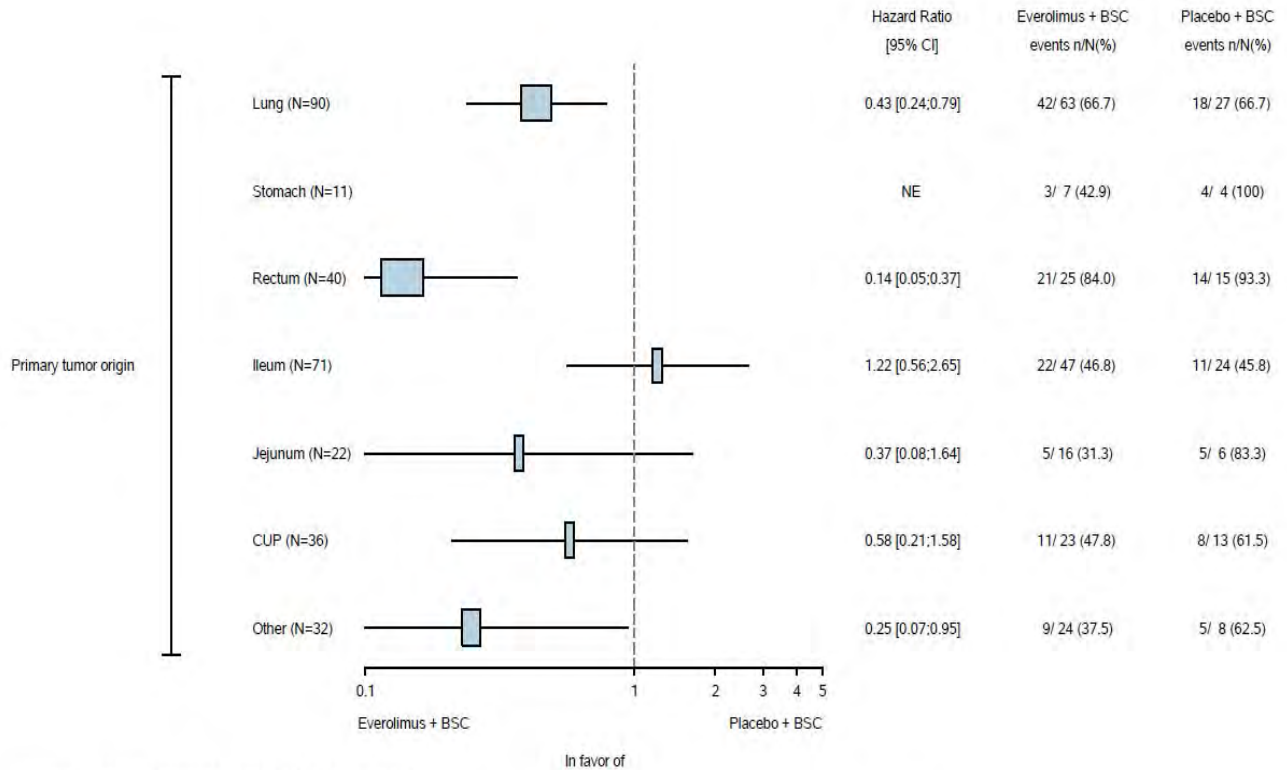

- Hazard ratio is obtained from stratified Cox model
- In Primary tumor origin category: Appendix, Caecum, Colon, Duodenum and Other are grouped as Other category.
- Cox model stratified by Prior SSA and WHO performance status as entered in the IRT at randomization.

The overall response rate as per independent assessment was 2% in the everolimus arm vs. 1% in the placebo arm. The overall survival (OS) analysis is not yet mature.

Clinically or statistically significant differences were not observed between the two treatment arms in terms of time to deterioration of WHO PS (≥ 1 point) and time to deterioration of FACT-G total score (≥ 7 points).

Lack of Efficacy in Locally Advanced or Metastatic Functional Carcinoid Tumours

Study C2325 (RADIANT-2)

The safety and effectiveness of AFINITOR in patients with locally advanced or metastatic functional carcinoid tumours was not demonstrated in study C2325. In this randomized (1:1), double-blind, multi-center trial in 429 patients with carcinoid tumours, AFINITOR plus depot octreotide (Sandostatin LAR) was compared to placebo plus depot octreotide. After documented radiological progression, patients on the placebo arm could receive AFINITOR; of those randomized to placebo, 143 (67%) patients received open-label AFINITOR plus depot octreotide. The study did not meet its primary efficacy endpoint of a statistically significant improvement in PFS and the final analysis of OS favored the placebo plus depot octreotide arm.

Metastatic RCC

The safety and efficacy of AFINITOR in the treatment of metastatic renal cell carcinoma (mRCC) were studied in a single randomised phase III trial.

Study C2240 (RECORD-1)

A phase III, international, multi-centre, randomised, double-blind study comparing AFINITOR 10 mg/day (2 x 5 mg tablets) and placebo, both in conjunction with best supportive care, was conducted in patients with mRCC whose disease had progressed despite prior treatment with the VEGF (vascular endothelial growth factor)-receptor tyrosine kinase inhibitors (TKIs) sunitinib, sorafenib, or both sunitinib and sorafenib. Prior therapy with bevacizumab, interleukin-2 or interferon-alpha was also permitted. Patients were stratified according to Memorial Sloan-Kettering Cancer Center (MSKCC) prognostic score (favourable- vs. intermediate- vs. poor-risk groups) and prior anticancer therapy (1 vs. 2 prior VEGF-receptor TKIs).

Progression-free survival, documented using RECIST (Response Evaluation Criteria in Solid Tumours) and assessed via a blinded, independent central review, was the primary endpoint. Secondary endpoints included safety, objective tumour response rate, overall survival, disease-related symptoms and quality of life. After documented radiological progression, patients could be unblinded by the investigator: those randomised to placebo were then able to receive open-label AFINITOR 10 mg/day. The Independent Data Monitoring Committee recommended termination of this trial at the time of the second interim analysis as the primary endpoint had been met.

In total, 416 patients were randomised 2:1 to receive AFINITOR (n=277) or placebo (n=139). Demographics were well balanced (see Table 24).

Table 24 Demographic and Disease Characteristics (mRCC)

Demographic or disease characteristic	AFINITOR N=277	Placebo N=139
Age (years)		
Median (range)	61.0 (27 to 85)	60.0 (29 to 79)
Age group (years) (n [%])		
< 65 years	165 (59.6)	98 (70.5)
≥ 65 years	112 (40.4)	41 (29.5)
Gender (n [%])		
Male	216 (78.0)	106 (76.3)
Female	61 (22.0)	33 (23.7)
Race (n [%])		
Caucasian	246 (88.8)	121 (87.1)
Asian	16 (5.8)	11 (7.9)
Black	2 (0.7)	3 (2.2)
Native American	1 (0.4)	0
Other/ Missing	9/4 (2.9/1.4)	3/1 (2.2/0.7)
MSKCC prognostic score [n (%)]		
Favourable risk	81 (29.2)	39 (28.1)
Intermediate risk	156 (56.3)	79 (56.8)
Poor risk	40 (14.4)	21 (15.1)
Prior VEGF-receptor TKI therapy [n (%)]		
One prior VEGF-receptor TKI	205 (74.0)	103 (74.1)
Two prior VEGF-receptor TKIs	72 (26.0)	36 (25.9)
Prior immunotherapy (n [%])	179 (64.6)	93 (66.9)

Results from a planned interim analysis showed that AFINITOR was superior to placebo for the primary endpoint of progression-free survival (PFS), with a statistically significant 67% reduction in the risk of progression or death. At 6 months, PFS rates were 36% for AFINITOR therapy compared with 9% for placebo (see Table 25 and Figure 8).

Table 25 Progression Free Survival results (mRCC)

Population	N	AFINITOR N=277	Placebo N=139	Hazard Ratio (95%CI)	p-value ^a
		Median progression-free survival (months) (95% CI)			
Primary analysis					
All (blinded independent central review)	416	4.9 (4.0 to 5.5)	1.9 (1.8 to 1.9)	0.33 (0.25 to 0.43)	<0.001 ^a
Supportive/sensitivity analyses					

Population	N	AFINITOR N=277	Placebo N=139	Hazard Ratio (95%CI)	p-value ^a
All (local review by investigator)	416	5.5 (4.6 to 5.8)	1.9 (1.8 to 2.2)	0.32 (0.25 to 0.41)	<0.001 ^a
MSKCC prognostic score					
Favourable risk	120	5.8 (4.0 to 7.4)	1.9 (1.9 to 2.8)	0.31 (0.19 to 0.50)	<0.001 ^b
Intermediate risk	235	4.5 (3.8 to 5.5)	1.8 (1.8 to 1.9)	0.32 (0.22 to 0.44)	<0.001 ^b
Poor risk	61	3.6 (1.9 to 4.6)	1.8 (1.8 to 3.6)	0.44 (0.22 to 0.85)	0.013 ^b

^a Log-rank test stratified by prognostic score

^b Unstratified, two-sided log-rank test

Figure 8 Kaplan-Meier progression-free survival curves

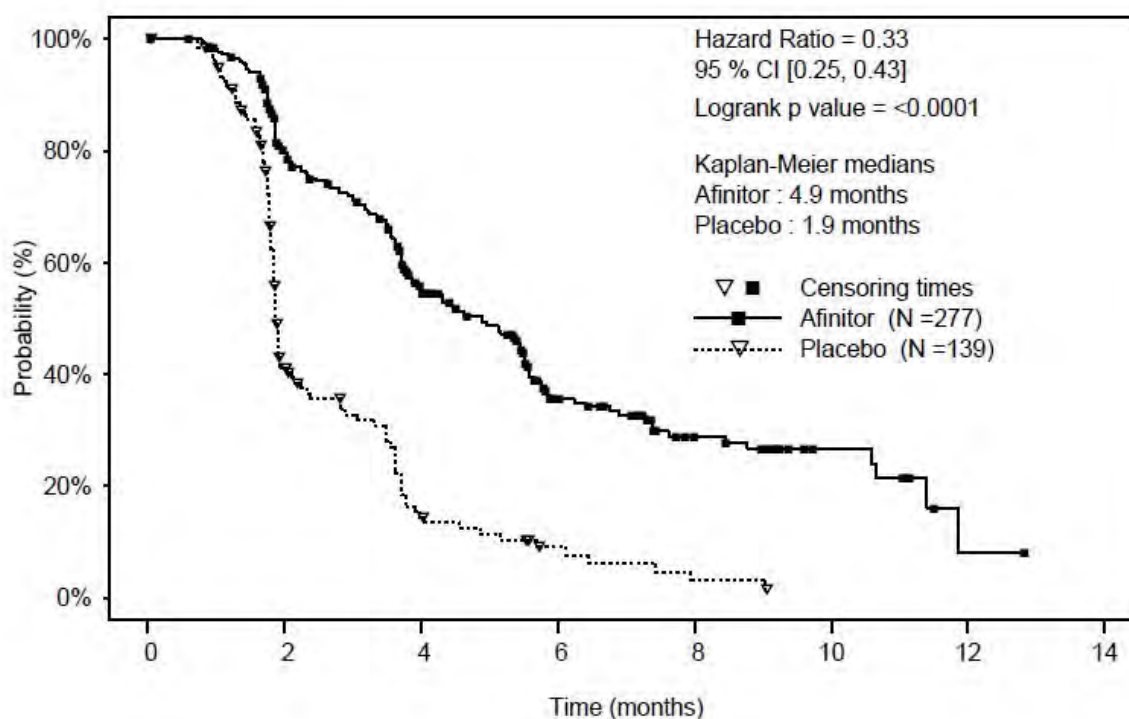

A low objective response rate (ORR) was observed with no significant differences apparent between the two treatment arms. ORR, based on RECIST, was documented in 1.8% (95% CI: 0.6-4.2%) of patients receiving everolimus therapy (vs. 0% for placebo); all 5 of these patients had partial responses. The progression-free survival advantage therefore primarily reflects the population with disease stabilisation (corresponding to 67% of the AFINITOR treatment group) (see Figure 9).

Figure 9 Waterfall plot: best percentage change from baseline of target lesions by central radiology

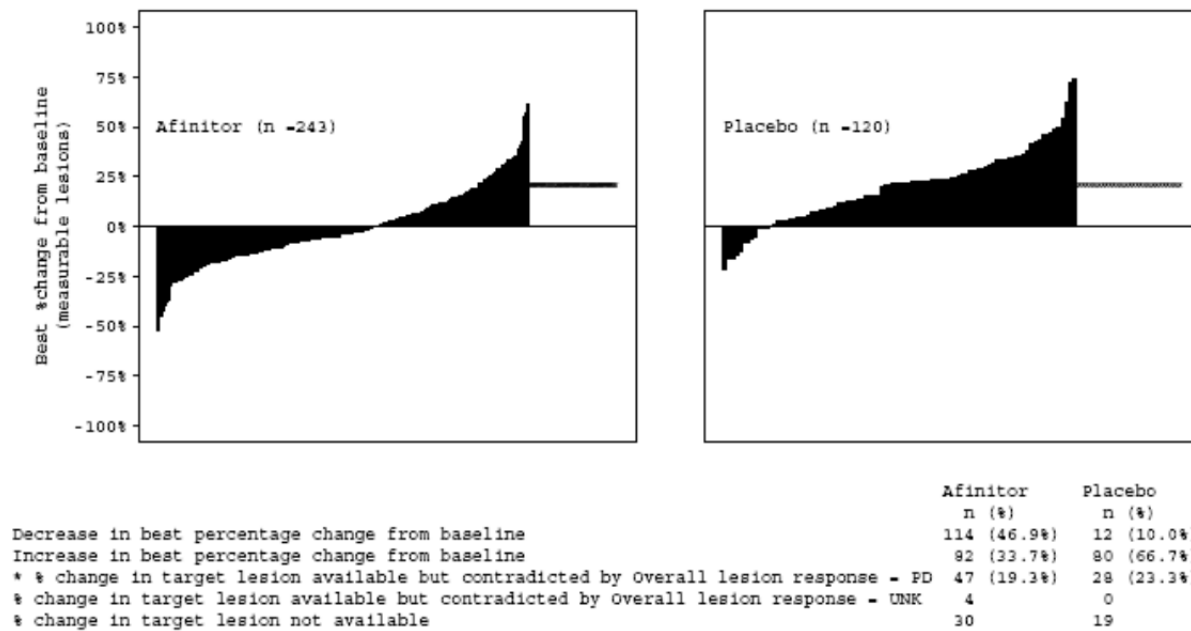

No statistically significant treatment-related difference in overall survival was noted, although there was a trend in favour of AFINITOR (HR 0.82; 95% CI: 0.57 to 1.17; p=0.137). Crossover to open-label AFINITOR following disease progression for patients allocated to placebo may have confounded the detection of any treatment-related difference in overall survival.

No difference in health-related quality of life was observed in patients receiving AFINITOR compared to placebo patients.

Renal Angiomyolipoma associated with Tuberous Sclerosis Complex

The safety and efficacy of AFINITOR in the treatment of renal angiomyolipoma associated with tuberous sclerosis complex (TSC) were studied in a phase III trial.

M2302 (EXIST-2)

A randomized, double-blind, multi-centre phase III study of AFINITOR versus placebo was conducted in patients who have renal angiomyolipoma associated with TSC (n=113) or with sporadic lymphangioliomyomatosis (LAM) (n=5). Presence of at least one angiomyolipoma ≥ 3 cm in longest diameter using CT/MRI (based on local radiology assessment), no immediate indication for surgery, and age ≥ 18 years were required for entry.

The primary efficacy endpoint for the trial was angiomyolipoma response rate based on independent central radiology review. Response was defined as: $\geq 50\%$ reduction in the sum of angiomyolipoma volume relative to baseline, plus absence of new angiomyolipoma ≥ 1.0 cm in longest diameter, plus no increases in renal volume $> 20\%$ from nadir, plus absence of grade ≥ 2

angiomyolipoma-related bleeding. The analysis was stratified by use of enzyme-inducing antiepileptic drugs (EIAEDs) at randomisation (yes/no).

Key secondary endpoints included time to angiomyolipoma progression and skin lesion response rate.

The primary analyses of efficacy endpoints were limited to the blinded treatment period which ended 6 months after the last patient was randomized. The median duration of follow-up was 8.3 months (range 0.7 to 24.8 months).

Patients initially treated with placebo were allowed to cross over to everolimus at the time of angiomyolipoma progression or after the primary analysis. At the time of the final analysis (4 years following the last patient randomization), the median duration of exposure to everolimus was 46.9 months (range 0.5 to 63.9 months).

A total of 118 patients were randomised in a 2:1 ratio to receive either AFINITOR 10 mg daily (n=79) or matching placebo (n=39) until disease progression or unacceptable toxicity. Demographic and baseline disease characteristics and history of prior anti-angiomyolipoma therapies were generally well balanced.

Table 26 Demographic and Disease Characteristics (Full Analysis Set) (Renal Angiomyolipoma associated with TSC)

Demographic or disease characteristic	AFINITOR N=79	Placebo N=39
Age (years)		
N	79	39
Mean (SD)	32.5 (10.4)	31.0 (9.6)
Median	32.0	29.0
Range	18 – 61	18 - 58
Age (years), n (%)		
18 to < 30	35 (44.3)	20 (51.3)
≥ 30	44 (55.7)	19 (48.7)
Gender, n (%)		
Female	52 (65.8)	26 (66.7)
Male	27 (34.2)	13 (33.3)
Race, n (%)		
Caucasian	71 (89.9)	34 (87.2)
Asian	7 (8.9)	4 (10.3)
Other ¹	1 (1.3)	1 (2.6)
Diagnosis of TSC²		
n (%)		
At least two major features	77 (97.5)	36 (92.3)
Only one major feature and at least two	0	0

Demographic or disease characteristic	AFINITOR N=79	Placebo N=39
minor features		
EIAED use/EIAED non-use (n, %)		
EIAED use	13 (16.5)	7 (17.9)
EIAED non-use	66 (83.5)	32 (82.1)
Longest diameter of largest angiomyolipoma²		
≥ 8cm	22 (27.8)	12 (30.8)
≥ 4cm and <8cm	45 (57.0)	19 (48.7)
≥ 3cm and <4cm	6 (7.6)	4 (10.3)
< 3cm	5 (6.3)	2 (5.1)
Number of target angiomyolipoma lesions ≥ 1cm in longest diameter (n, %)		
1-5	32 (40.5)	15 (38.5)
6-10	46 (58.2)	23 (59.0)
Number of patients with angiomyolipoma lesions present in (n, %)		
One kidney only	13 (16.7)	11 (28.9)
Both kidneys	65 (83.3)	27 (71.1)
Sum of volumes of target angiomyolipoma lesions (cm³)²		
Median	85.4	119.8
Range	8.6 – 1611.5	3.0 – 4520.0
Prior anti-angiomyolipoma therapy (surgery/invasive procedure)		
Renal embolization	19 (24.1)	9 (23.1)
Nephrectomy	14 (17.7)	8 (20.5)
Number of patients with ≥ 1 skin lesion at baseline	77 (97.5)	37 (94.9)

¹ Other was applied to patients of mixed race

² Baseline kidney CT/MRI assessments were per central radiology review

Results showed that AFINITOR was statistically superior to placebo for the primary efficacy endpoint of angiomyolipoma response rate ($p < 0.0001$). Best overall response rate was 41.8% (95% CI: 30.8, 53.4) for the AFINITOR arm compared with 0% (95% CI: 0.0, 9.0) for the placebo arm (Figure 8). Consistent treatment effects were observed across all subgroups evaluated (i.e., EIAED use vs. EIAED non-use, sex, age and race) at the primary efficacy analysis (Figure 10).

Figure 10 Forest plot of angiomyolipoma response by subgroup (Full Analysis Set) at primary analysis

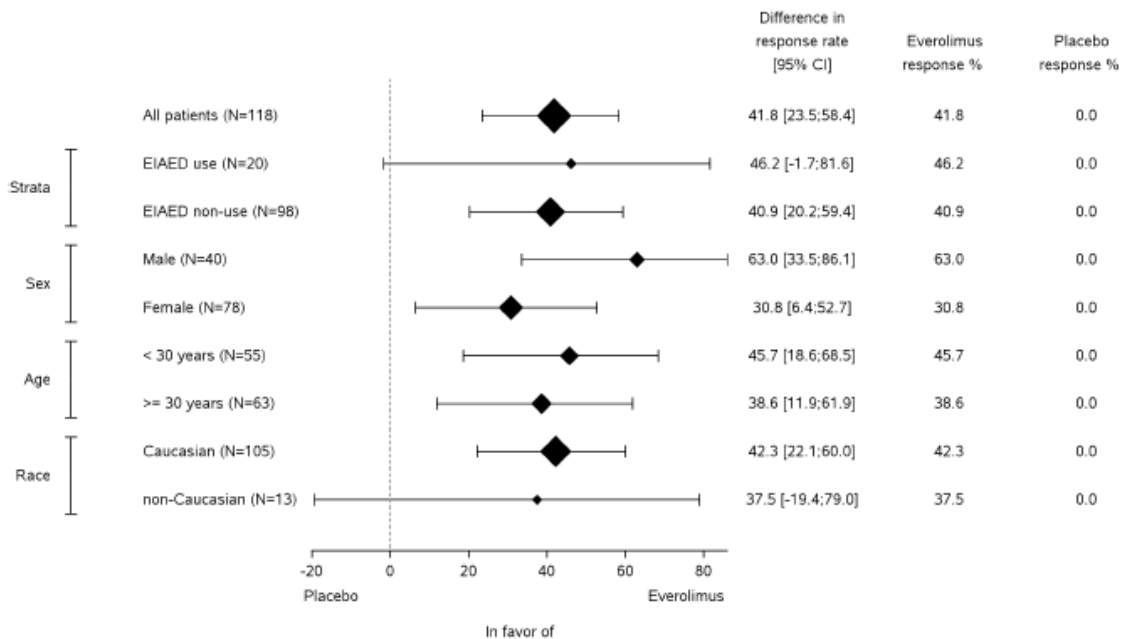
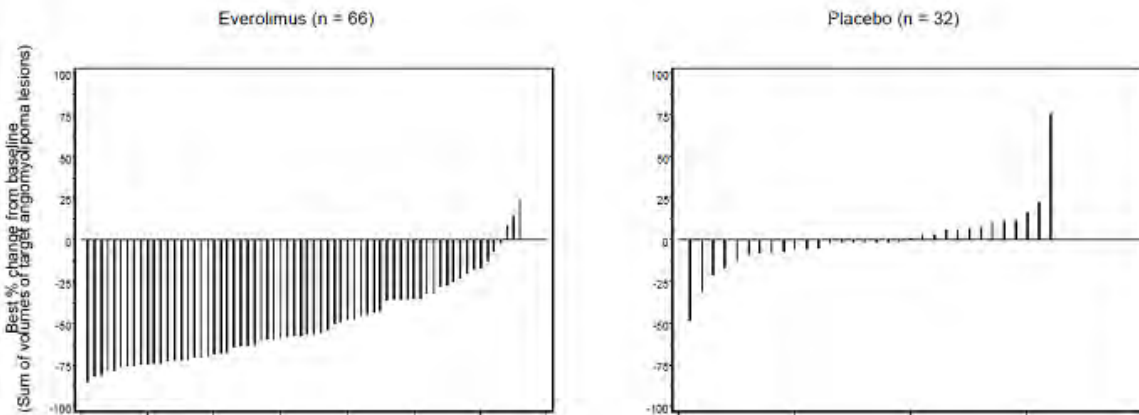

Table 27 Angiomyolipoma Response

	Primary Analysis			Final analysis
	AFINITOR N=79	Placebo N=39	p-value	AFINITOR N=112
Angiomyolipoma response rate ^a - %	41.8	0	<0.0001	58.0
95% CI	(30.8, 53.4)	(0.0, 9.0)		(48.3, 67.3)

^a Per independent central radiology review

Figure 11 Waterfall plot: Angiomyolipoma shrinkage: best percentage change from baseline (Full Analysis Set)^{1,2} at primary analysis



¹ Per independent central radiology review

² Patients for whom the best % change in sum of volumes of target angiomyolipoma lesions was not available and patients with overall angiomyolipoma response = Not evaluable were excluded from the graph

At the primary analysis, progressions were observed in 3.8% (3/79) of patients in the AFINITOR arm compared with 20.5% (8/39) of patients in the placebo arm. AFINITOR was associated with a statistically significant prolongation in time to angiomyolipoma progression (HR 0.08; 95% CI: 0.02, 0.37; $p < 0.0001$). Median time to angiomyolipoma progression was 11.4 months in the placebo arm and was not reached in the AFINITOR arm.

At the final analysis, the angiomyolipoma best overall response rate had increased to 58.0% (95% CI: 48.3, 67.3). Median time to angiomyolipoma progression was not reached. Angiomyolipoma progressions were observed in 14.3% of the patients (16/112). The estimated angiomyolipoma progression-free rates at 24 months and 48 months were 91.6% (95% CI: 84.0%, 95.7%) and 83.1% (95% CI: 73.4%, 89.5%) respectively. No cases of angiomyolipoma-related nephrectomy and only one case of renal embolization were reported among patients treated with everolimus during the study.

At the primary analysis, AFINITOR also demonstrated improvements in skin lesion response ($p = 0.0002$), with partial response rates of 26.0% (20/77) for the AFINITOR arm and 0% (0/37) for the placebo arm. At the final analysis, the overall skin lesion response rate had increased to 68.2% (73/107) (95% CI: 58.5%, 76.9%).

SEGA associated with Tuberous Sclerosis Complex

The safety and efficacy of AFINITOR in the treatment of subependymal giant cell astrocytoma (SEGA) associated with tuberous sclerosis complex (TSC) were studied in a phase III trial.

Study M2301 (EXIST-1)

A randomized, double-blind, multicentre, phase III study of AFINITOR versus placebo was conducted in 117 patients with SEGA associated with TSC. Patients were randomised in a 2:1 ratio to receive either AFINITOR or placebo. Eligible patients had the presence of at least one SEGA lesion ≥ 1.0 cm in longest diameter using MRI (based on local radiology assessment) and one or more of the following: serial radiological evidence of SEGA growth, a new SEGA lesion ≥ 1 cm in longest diameter, or new or worsening hydrocephalus. Patients randomized to the treatment arm received AFINITOR at a starting dose of 4.5 mg/m² daily, with subsequent dose adjustments as needed, to achieve and maintain everolimus trough concentrations of 5 to 15 ng/mL, as tolerated.

The primary efficacy endpoint was SEGA response rate based on independent central radiology review. Analysis of SEGA response rate was limited to the blinded treatment period which ended 6 months after the last patient was randomised. The analysis was stratified by use of enzyme-inducing antiepileptic drugs (EIAEDs) at randomisation (yes/no).

Key secondary endpoints included time to SEGA progression and skin lesion response rate. Renal angiomyolipoma response was an exploratory endpoint.

Of the 117 patients enrolled, 78 were randomised to AFINITOR and 39 were randomised to placebo. The two treatment arms were generally well balanced with respect to demographic and baseline disease characteristics and history of prior anti-SEGA therapies. The median duration of blinded study treatment was 52.2 weeks (range 24 to 89 weeks) for patients receiving AFINITOR and 46.6 weeks (range 14 to 88 weeks) for those receiving placebo.

Table 28 Demographic and Disease Characteristics

Demographic or disease characteristic	AFINITOR N=78 n (%)	Placebo N=39 n (%)	Total N=117 n (%)
Age (years)			
Mean (standard deviation)	10.1 (5.9)	10.3 (7.3)	10.2 (6.4)
Median	9.5	7.1	9.5
Range	1.0 to 23.9	0.8 to 26.6	0.8 to 26.6
Age group (years) (n [%])			
< 3	13 (16.7)	7 (17.9)	20 (17.1)
3 to < 18	55 (70.5)	26 (66.7)	81 (69.2)
≥ 18	10 (12.8)	6 (15.4)	16 (13.7)
Gender			
Male	49 (62.8)	18 (46.2)	67 (57.3)
Female	29 (37.2)	21 (53.8)	50 (42.7)
Race			
Caucasian	73 (93.6)	36 (92.6)	109 (93.2)
Black	3 (3.8)	1 (2.6)	4 (3.4)
Other ^a	1 (1.3)	2 (5.1)	3 (2.6)
Number of target SEGA lesions			
Bilateral SEGA	63 (80.8)	30 (76.9)	93 (79.5)
≥ 2	36 (46.2)	14 (35.9)	50 (42.7)
Brain MRI assessment			
Inferior growth	19 (24.4)	11 (28.2)	30 (25.6)
Evidence of deep parenchymal invasion	8 (10.3)	3 (7.7)	11 (9.4)

Demographic or disease characteristic	AFINITOR N=78 n (%)	Placebo N=39 n (%)	Total N=117 n (%)
Radiographic evidence of hydrocephalus	8 (10.3)	0 (0.0)	8 (6.8)
Skin and subcutaneous tissue disorders			
At least one skin lesion	72 (92.3)	38 (97.4)	110 (94.0)
Prior SEGA-related surgery	6 (7.7)	2 (5.1)	8 (6.8)

^a 'Other' was applied to patients who were of mixed race

Results showed that AFINITOR was superior to placebo for the primary endpoint of best overall SEGA response ($p < 0.0001$) (Table 29). At the time of primary analysis, all SEGA responses were on-going and the median duration of response was 5.3 months (range 2.1 to 8.4 months).

Patients initially treated with placebo were allowed to cross over to AFINITOR at the time of SEGA progression and upon recognition that treatment with AFINITOR was superior to treatment with placebo. All patients receiving at least one dose of AFINITOR were followed until drug discontinuation or study completion. At the time of final analysis, the median duration of exposure to AFINITOR among all such patients was 204.9 weeks (range 8.1 to 253.7). The best overall SEGA response rate had increased to 57.7% (95% CI: 47.9, 67.0) at the final analysis (Table 29).

Table 29 SEGA response (Study EXIST-1)

	Primary analysis³			Final analysis⁴
	AFINITOR N=78	Placebo N=39	p-value	AFINITOR
SEGA response rate ^{1,2} (%)	34.6	0	<0.0001	57.7
95% CI	24.2, 46.2	0.0, 9.0		47.9, 67.0

¹ Per independent central radiology review

² SEGA responses were confirmed with a repeat scan. Response was defined as: $\geq 50\%$ reduction in the sum of SEGA volume relative to baseline, plus no unequivocal worsening of non-target SEGA lesions, plus absence of new SEGA ≥ 1 cm in longest diameter, plus no new or worsening hydrocephalus.

³ Primary analysis for double blind period

⁴ Final analysis includes patients who crossed over from the placebo group; median duration of exposure to everolimus of 204.9 weeks

Consistent treatment effects were observed across all subgroups evaluated (i.e., EIAED use vs. EIAED non-use, sex and age) at the primary analysis (Figure 12).

Figure 12 Forest plot of SEGA response by subgroup at primary analysis

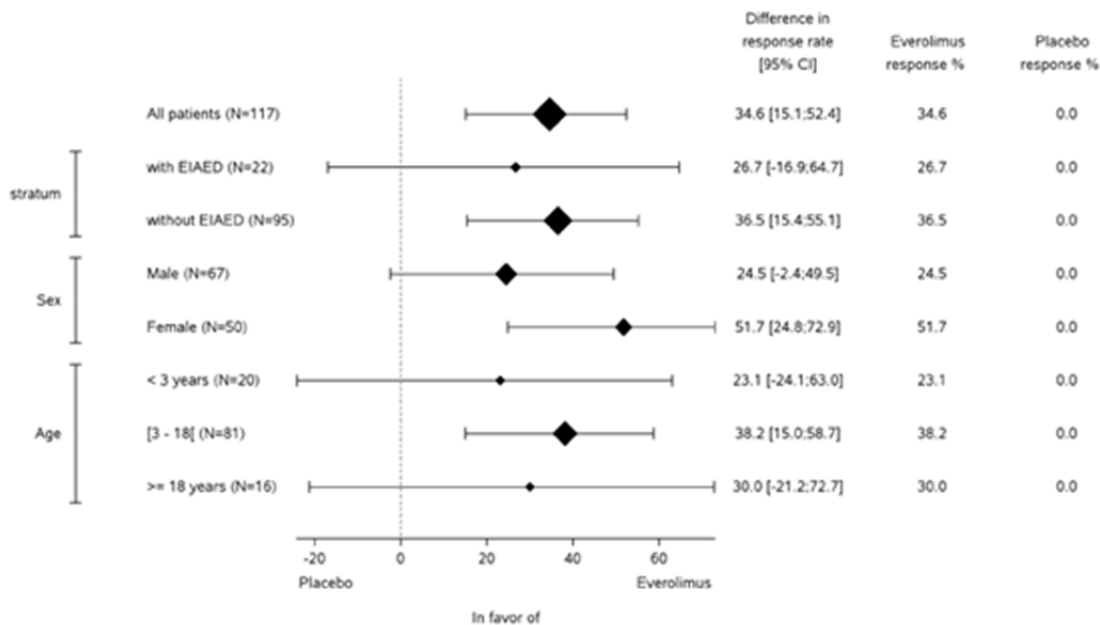

During the double blind period, reduction of SEGA volume was evident within the initial 12 weeks of treatment with AFINITOR: 29.7% (22/74) of patients had $\geq 50\%$ reductions in volume and 73.0% (54/74) of patients had $\geq 30\%$ reductions in volume. At Week 24, 41.9% (31/74) of patients had $\geq 50\%$ reductions and 78.4% (58/74) of patients had $\geq 30\%$ reductions in SEGA volume.

In the AFINITOR treated population (N=111) of the study, including patients who crossed over from the placebo group, tumour response, starting as early as after 12 weeks on AFINITOR, was sustained at later time points. The proportion of patients achieving at least 50% or at least 30% reductions in SEGA volume were 62.1% (41/66) and 77.3% (51/66) respectively, at Week 192 after start of AFINITOR treatment.

Progressions were only observed in the placebo arm (15.4%) during the blinded phase of the study. Thirteen of the 111 patients (11.7%) treated with AFINITOR had documented disease progression by the end of the follow-up period.

AFINITOR demonstrated improvements in skin lesion response with response rates of 41.7% for the AFINITOR arm and 10.5% for the placebo arm. At the final analysis, the skin lesion response rate increased to 58.1% (95% CI: 48.1, 67.7).

At the time of the primary analysis, renal angiomyolipoma responses were only observed in the AFINITOR arm (n/N:16/30; 53.3%; 95% CI: 34.3, 71.7). At the time of final analysis, among the 41 TSC-SEGA in patients with an angiomyolipoma lesion(s) present at start of treatment with AFINITOR. 30 patients (73.2 %; 95% CI: 57.1, 85.8) achieved, as their best overall response, at least a 50% reduction in sum of angiomyolipoma volumes.

No patient required surgical intervention for SEGA during the entire course of the study.

Seizures associated with Tuberous Sclerosis Complex

Study M2304 (EXIST-3)

The safety and efficacy of AFINITOR DISPERZ as adjunctive therapy in the treatment of seizures associated with tuberous sclerosis complex (TSC) were studied in a randomized, double-blind, placebo-controlled, multicenter, phase III trial. This study included 366 patients (247 patients were exposed to everolimus and 119 received placebo). The patients' mean age was approximately 13 years (Median: 10 years; Range: 2 to 56 years). All patients had a definite diagnosis of TSC. Approximately half the patients were male.

Patients had partial-onset seizures with or without secondary generalization and were not satisfactorily controlled with combinations of anti-epileptic drugs (AEDs). During the 8-week Baseline phase, patients were required to have ≥ 16 seizures per 28 days. The Core treatment phase of the study was 18 weeks in duration (including a 6 week Titration period and a 12 week Maintenance period). The study consisted of three arms and compared two doses of everolimus (low trough [LT]: 3-7 ng/mL and high trough [HT]: 9-15 ng/mL) with placebo. Across all arms, approximately 95% of the patients completed the Core treatment phase of the study.

Study Results

A statistically significant treatment effect was observed for both doses of AFINITOR DISPERZ relative to placebo ($p=0.003$ [LT] and $p<0.001$ [HT]) for the median percent reduction from Baseline in seizure frequency during the Maintenance period of the Core Treatment Phase. This was supported by the analysis of responder rate during the Maintenance period of the Core treatment phase (Table 30). Efficacy results from the entire Core Treatment Phase (Titration + Maintenance periods) support the results from the Maintenance period of the Core Treatment Phase.

Table 30 Median Percent Reduction in Seizure Frequency and Proportion of Patients with at least a 50% Reduction in Seizure Frequency from Baseline (Full Analysis Set)

Efficacy Results ^a	AEDs + Placebo N=119	AEDs + AFINITOR DISPERZ	
		LT Target 3-7 ng/mL N=117	HT Target 9-15 ng/mL N=130
Median percent reduction from Baseline during the Maintenance period of the Core treatment phase	14.9	29.3	39.6
p-value versus placebo		0.003	<0.001
Responder Rate from Baseline during the Maintenance period of the Core treatment phase	15.1	28.2	40.0

p-value versus placebo ^c		0.008	<0.001
-------------------------------------	--	-------	--------

^a The primary efficacy endpoint was the median percent reduction from Baseline during the Maintenance period of the Core treatment phase. Responder rate was defined as percentage of patients who achieved at least a 50% reduction from Baseline in seizure frequency during the Maintenance period of the Core treatment phase.

At the end of the Core treatment phase, roughly 4% of the patients in AFINITOR DISPERZ arms became seizure-free vs about 1% in placebo.

There were no significant differences in seizure control as a function of gender. Data on race were limited (approximately 35% of the patients were non-Caucasian).

Comparative Bioavailability Studies

Table 31 presents the results of a randomized, open label, cross-over study in 53 healthy volunteers comparing the bioavailability of the AFINITOR DISPERZ 5 mg tablet for oral suspension to the AFINITOR 5 mg tablet.

Table 31 Single dose bioavailability study 1

Everolimus (1 x 5 mg AFINITOR tablet and 1 x 5 mg AFINITOR DISPERZ tablet for oral suspension) From measured data Geometric Mean Arithmetic Mean (CV %)				
--	--	--	--	--

Parameter	AFINITOR DISPERZ 5 mg Tablet for oral suspension (Test)	AFINITOR 5 mg Tablet (Reference)	Ratio of Geometric Means	90% Confidence Interval
AUC _{0-72h} (ng.h/mL)	190.11 196.62 (26.00)	211.56 220.44 (32.29)	0.90	0.85, 0.95
AUC _{0-∞} (ng.h/mL)	230.95 238.17 (24.90)	252.47 262.63 (31.38) ¹	0.91	0.86, 0.96
C _{MAX} (ng/mL)	25.73 26.59 (25.55)	31.98 33.09 (29.22)	0.80	0.75, 0.86
T _{MAX} [§] (h)	1.5 (0.5, 4.0)	1.00 (0.5, 3.0)		
T _{1/2} [‡] (h)	34.92 (19.23) ²	33.30 (15.14)		

¹ N=52 for AUC_{0-∞} for the 5 mg tablet

² N=52 for T_{1/2} for the 5 mg tablet for oral suspension

[§] Expressed as median (range)

[‡] Expressed as the arithmetic mean (CV%)

Table 32 presents the results of a randomized, open label, cross-over study in 51 healthy

volunteers comparing the bioavailability of the AFINITOR DISPERZ 5 mg tablet for oral suspension to the 5 x 1 mg everolimus tablets.

Table 32 Single dose bioavailability study 2

Everolimus (5 x 1 mg everolimus tablets and 1 x 5 mg AFINITOR DISPERZ tablet for oral suspension) From measured data Geometric Mean Arithmetic Mean (CV %)				
---	--	--	--	--

Parameter	AFINITOR DISPERZ 5 mg Tablet for oral suspension (Test)	5 x 1 mg everolimus tablets (Reference)	Ratio of Geometric Means	90% Confidence Interval
AUC _{0-72h} (ng.h/mL)	186.49 194.78 (31.28)	214.11 224.32 (32.72)	0.86	0.80, 0.93
AUC _{0-∞} (ng.h/mL)	219.69 230.62 (33.55)	254.62 266.76 (32.79)	0.86	0.80, 0.93
C _{MAX} (ng/mL)	25.45 26.68 (30.62)	39.68 41.10 (27.95)	0.64	0.60, 0.68
T _{MAX} [§] (h)	1.50 (0.5, 4.0)	0.50 (0.5, 2.0)		
T _{1/2} [‡] (h)	32.81 (20.08)	34.03 (31.60)		

[§] Expressed as median (range).

[‡] Expressed as the arithmetic mean (CV%).

DETAILED PHARMACOLOGY

This section includes animal data on everolimus pharmacology not derived from human studies.

Nonclinical Pharmacology

***In vitro* pharmacology**

Everolimus binds with high affinity to the intracellular immunophilin, FKBP-12 resulting in inhibition of the mTORC1 complex and consequently, suppression of downstream events such as S6K and 4EBP activity and cell-cycle arrest from G1 to S phase. No activity was found against the following kinases: HER-1, HER-2, KDR, IGF1-R, FGFR-1, c-met, c-src, c-kit, and CDK1. Everolimus shows a very broad inhibition of tumour cell lines (i.e. inhibits tumour proliferation) of different histotypes *in vitro* with high sensitivity to anti-proliferative effects in some cells (as determined by measuring the number of cells) (IC₅₀ <1 nM) and insensitivity in others (IC₅₀ >1 µM), although the majority of cell lines tested (80%) had IC₅₀ values <100 nM. Specifically, in

renal cancer models, everolimus showed significant activity: a panel of 16 human RCC cell lines were tested *in vitro* for anti-proliferative activity of everolimus; 14 were sensitive to everolimus treatment with IC₅₀s in the low/sub nM range, while two renal cell lines were insensitive (IC₅₀ >2500 nM). The sensitivity of RCC cell lines was similar to that described for other histotypes *in vitro*. VHL genetic status did not affect the anti-proliferative response to everolimus in the renal cell panel *in vitro*: three out of the four VHL wild-type lines were very sensitive to everolimus treatment with similar IC₅₀s (in the low/sub nM range) as observed in the VHL negative lines. Moreover, exogenous expression of VHL in a VHL negative background had little effect and the two lines defined as insensitive to everolimus treatment were VHL wild type (Caki-1) and VHL negative (Caki-2).

***In vivo* pharmacology**

Cell lines insensitive to everolimus *in vitro* responded to the drug when grown as tumours in mice. This was noted by a decrease in tumour-volume suggesting a significant anti-vascular/angiogenic activity of everolimus consistent with the ability of this drug to decrease levels of HIF-1 and VEGF in tumours *in vivo*. Thus everolimus is expected to inhibit cancer cell growth by mechanisms directed against both tumour cells and the surrounding cellular milieu. Two of the human RCC cell lines (786-O and Caki-1) were also tested for sensitivity to everolimus *in vivo* by growing them subcutaneously (s.c.) in athymic nude mice. Everolimus showed significant dose-dependent inhibition of growth, and in the more sensitive cell line (786-O) caused tumour regression.

In a mouse neuronal model of TSC in which *TSC1* is ablated in most neurons during cortical development, everolimus improved median survival from 33 days to more than 100 days, and behaviour, phenotype and weight gain also markedly improved. There was brain penetration, with accumulation over time with repetitive treatment, and effective reduction of levels of phospho-S6, a downstream marker of mTORC1. Neurofilament abnormalities, myelination and cell enlargement were all improved by the treatment, although dysplastic neuronal features persisted, and there were only modest changes in dendritic spine density and length. Mice treated with everolimus for 23 days only (postnatal days 7–30) displayed a persistent improvement in phenotype, with median survival of 78 days. In summary, everolimus is highly active in this neuronal model of TSC, with benefit apparently attributable to effects on mTORC1 and Akt signalling and, consequently, cell size and myelination.

Safety Pharmacology

The studies related to safety pharmacology showed that everolimus was devoid of relevant effects on vital functions including the cardiovascular function, respiratory function and nervous systems.

In stably transfected HEK293 cells, everolimus inhibited hERG currents by 18% at 10 µM (concentration experimentally verified). Higher concentrations could not be tested because of solubility limitations. In sheep isolated Purkinje fibres, everolimus prolonged the action potential duration at 90% repolarization (APD90) by 5.0% at 1.04 µM and 4.7% at 10.0 µM (nominal concentrations). In male pigs (N=4) anaesthetized with ketamine and sodium pentobarbital, everolimus at escalating intravenous doses of 0, 0.01, 0.1, 1, and 10 mg/kg was not observed to affect the mean arterial blood pressure, systolic blood pressure, diastolic blood

pressure, heart rate, or ECG parameters over 30 minute post-dose observation periods. The study lacked a time-matched vehicle control arm.

Although everolimus passes the blood-brain barrier, there was no indication of relevant changes in the behaviour of rodents, even after single oral doses up to 2000 mg/kg.

Based on these findings, the potential of everolimus to affect vital functions in patients is considered to be low.

Nonclinical Pharmacokinetics

See also **ACTION AND CLINICAL PHARMACOLOGY**.

Absorption/Bioavailability: The oral absorption of everolimus was low in mice (12%) and monkeys (18%) and medium in rats (~ 40%). The bioavailability of unchanged everolimus was 14-26% in the rat and 6% in the monkey, suggesting considerable first-pass metabolism. Everolimus is a substrate for P-glycoprotein mediated efflux systems (MDR1). After an intravenous dose to mice (0.9 mg/kg), rats (1 mg/kg) and monkeys (1 mg/kg), terminal half-lives of about 9.8 hours, 60 hours, and 27 hours were observed, respectively. After an oral dose of [³H]everolimus to rats (1.5 and 15 mg/kg) and monkeys (5 mg/kg), terminal half-lives of about 61 and 47 hours in rats and 18 hours in monkeys were observed. Multiple oral dosing of [³H]everolimus over 21 days (0.5 mg/kg/day) to rats increases 24-hour trough levels of radioactivity in blood by 4.4-fold compared to Day 1. In the rat, the blood clearance was moderate and corresponded to about 38% and 59% of the hepatic blood flow. In the mouse and monkey, the blood clearance was significantly lower, corresponding to about 0.9% and 7% of the hepatic blood flow, respectively.

Distribution: In plasma, the free fraction of everolimus was independent of concentration and averaged 7.6% in the rat, 16% in the monkey and 25% in human, but only 0.1% in the mouse. With the exception of the mouse, the blood distribution of everolimus was concentration-dependent. At a concentration of 5 ng/mL the distribution was 66%, 79% and 83% in rat, monkey and human, respectively. In the mouse blood, the majority of everolimus (~ 98%) was located in plasma. The volume of distribution at steady-state (V_{ss}) was species-dependent and ranged from high in the rat (44-52 L/kg) to very low in the mouse (0.37 L/kg). An intermediate value could be estimated for human ($V_z/F= 14.2$ L/kg). In rats, tissue distribution of radioactivity was essentially extravascular with highest levels found in heart, lung, liver, kidney, spleen, thyroid and adrenal gland. Everolimus and/or its metabolites displayed no special affinity to melanin-containing tissue of the pigmented rat. Unchanged everolimus was the major component of tissues radioactivity of rats after single oral or intravenous administration. In the rat, the blood-brain passage of everolimus and/or its metabolites was found to be dose-dependent. [³H]Everolimus-related radioactivity passed the placenta of pregnant rats to a limited degree and was readily transferred into milk of lactating rats.

Metabolism: Everolimus is mainly eliminated by metabolism in the mouse, rat, monkey and human. Everolimus was the main circulating drug-related component in blood of all species. In all species everolimus formed a large number of metabolites. The metabolite patterns in the blood were comparable in all species including man. Everolimus is essentially metabolized

through oxidation by CYP3A4 in the liver and to some extent in the gut wall. Therefore, co-mediations that are strong inducers of CYP3A4 have the potential to reduce everolimus metabolism *in vivo*. Conversely, everolimus inhibited competitively the metabolism of the CYP3A4 substrate cyclosporine ($K_i = 2.3 \mu\text{mol/L}$) and was also a mixed inhibitor of the metabolism of the CYP2D6 substrate dextromethorphan ($K_i = 1.7 \mu\text{mol/L}$) *in vitro*. Apart from parent drug, essentially five main metabolite peaks P36, P40, P42, P50 and P57, containing six metabolites were observed. The main metabolites P40, P36, P42, P50 and P57 were approximately two orders of magnitudes less active than everolimus in a mixed lymphocyte reaction (MLR) assay. Essentially the same metabolites of everolimus in humans were formed by at least one of the animal species *in vivo* and/or *in vitro*.

Elimination/Excretion: Everolimus was predominantly eliminated through metabolic biliary/faecal clearance in all animal species and in human. Excretion was essentially complete in all species. Renal excretion was a minor component (0.7-7%). No unchanged drug was detected in urine or faeces.

Conclusion: Overall, the pharmacokinetic and metabolism data from mouse, rat and monkey indicate that these species are adequate for non clinical pharmacology and toxicology studies with everolimus.

Human Pharmacology

Absorption and Distribution

Based on the amount of radioactivity excreted in urine in the mass balance study in maintenance renal transplant patients, the extent of absorption was estimated to be 11% or higher based on the amount of radio-labelled compounds present in blood at t_{max} . In patients with advanced solid tumours, the steady-state $\text{AUC}_{0-\tau}$ is dose-proportional over the 5 mg and 10 mg dose range in the daily regimen and 5 mg to 70 mg in the weekly regimen. C_{max} is dose-proportional between 5 and 10 mg for both the weekly and daily regimens. At doses of 20 mg/week and higher, the increase in C_{max} is less than dose-proportional. Pre-dose trough blood concentrations (C_{min}) correlate well with $\text{AUC}_{0-\tau}$ at steady-state during daily administration. The *in vitro* distribution of everolimus between human blood cells and plasma was concentration-dependent. The proportion of everolimus confined to plasma ranged from 17 to 73% over the concentration range of 5 to 5000 ng/mL. The saturation of blood cell uptake was evident at concentrations above 100 ng/mL. The proportion of everolimus confined to plasma was approximately 20% at blood concentrations observed in cancer patients given 10 mg/day of everolimus. Plasma protein binding is approximately 74% in healthy subjects as well as patients with moderate hepatic impairment.

Metabolism and Elimination

The major and nearly exclusive enzyme responsible for the metabolism of everolimus in man is CYP3A4. Everolimus is a moderate inhibitor of P-gP-like mediated efflux systems. After an oral ^{14}C -labelled dose of everolimus, 85% of the radioactivity was recovered within 10 days in faeces (80%) and urine (5%). Unchanged everolimus accounted for about 40% of the AUC of total radioactivity in blood but was not detected in faeces or urine. Japanese and Caucasian cancer patients with similar liver functions have similar CL/F values. Age and weight (both over the

adult ranges) and gender do not have significant effects on pharmacokinetics of everolimus in cancer and transplant patients. Pharmacokinetics in healthy subjects are not altered by Japanese or Asian ethnicity. Black renal transplant patients have a 20% higher apparent clearance compared with non-blacks. As expected from the low renal excretion of parent compound, post-transplant renal impairment does not affect the pharmacokinetics of everolimus. Mean exposure ($AUC_{0-\infty}$) to everolimus is increased in patients with hepatic impairment. In one study, compared to normal subjects, there was a 2.2-fold increase in exposure for subjects with moderate hepatic impairment (Child-Pugh B, score 7 to 9). In a second study there was a 1.6-fold, 3.3-fold and 3.6-fold increase in exposure for subjects with mild (Child-Pugh A, score 5 to 6), moderate (Child-Pugh B, score 7 to 9) and severe (Child-Pugh C, score 10 to 15) hepatic impairment respectively, compared to normal subjects. The strong inhibitor of CYP3A4 and PgP, ketoconazole, increases everolimus $AUC_{0-\infty}$ 15.0-fold. The moderate inhibitors of CYP3A4 and PgP, erythromycin and verapamil, increase everolimus $AUC_{0-\infty}$ 4.4-fold and 3.5-fold, respectively. The CYP3A4 substrate and inhibitor of PgP, cyclosporine (NEORAL[®]) increases everolimus $AUC_{0-\infty}$ 2.7-fold. The CYP3A4 substrate atorvastatin did not influence the pharmacokinetics of everolimus. The CYP3A4 and PgP substrate paclitaxel did not influence the pharmacokinetics of everolimus. The everolimus doses used in these drug interaction studies ranged from 1 to 4 mg. Drug interaction studies at the 10 mg dose have not been conducted. The strong inducer rifampin decreases everolimus $AUC_{0-\infty}$ to 0.4-times the pre-treatment value. Pravastatin and gemcitabine are not substrates of CYP3A4 and do not have effects on the pharmacokinetics of everolimus. Co-administration of everolimus and SANDOSTATIN LAR did not have clinically significant effects on the pre-dose trough concentrations of everolimus and octreotide.

TOXICOLOGY

Single Dose Toxicity Studies

Single dose toxicity studies were conducted in rats and mice. Everolimus showed a low acute toxic potential after oral administration in mice and rats. No lethality or severe toxicity was observed after single oral doses of 2000 mg/kg (limit test) in either mice or rats. The low oral acute toxicity indicates that there is a minimal risk of intoxication following accidental or deliberate overdosing.

Repeated Dose Toxicity Studies

Repeated dose toxicity studies were performed in mice over 13 weeks, in rats up to 26 weeks, in minipigs up to 4 weeks and in monkeys up to 52 weeks. The study design and major findings of the repeated dose toxicity studies are shown in Table 33. The monkey was selected as a non-rodent species because gastrointestinal intolerance of everolimus was seen in the oral rising-dose study in the dog, precluding this species from treatment for longer periods. Similar findings have been reported with rapamycin in this species.

Table 33 Repeated dose toxicity studies

Species (strain)	Duration	Route	No./ groups	Dose (mg/kg)	Major findings
Mouse	13 weeks	Oral, gavage	10m, 10f	0, 0.15, 0.5, 1.5, 5, 15	<ul style="list-style-type: none"> • ≥ 0.15 mg/kg: higher incidence of swollen spleen • ≥ 0.5 mg/kg: reduced testes and epididymides weight, depletion of germ cells and vacuolation of the germinal epithelium of testis, reduced sperm content and germ cells in tubular lumina of epididymides (m), skin lesions (f), increased microvesiculation of zona glomerulosa and/or zona fasciculate of the adrenals (m), thymic atrophy • ≥ 1.5 mg/kg: higher liver weight (m), slightly higher cholesterol (m), skin lesions (+m), foamy alveolar macrophages (f), reduced ovarian follicular development and atrophy of uterus (f) • ≥ 5 mg/kg: lower body weight gain (m), higher incidence of skin abrasions (m), higher cholesterol (+f), reduced uterus weight (f), renal tubular degeneration with karyomegaly and interstitial inflammation (m), foamy alveolar macrophages (+m) • 15 mg/kg: high incidence of skin abrasions (+f), higher creatinine concentrations (m), lower albumin and A/G ratio (m), reduced thymus weight and higher spleen weight (m), higher liver weight (+f), renal tubular degeneration with karyomegaly and interstitial inflammation (+f) • NTEL=0.15 (m), and 0.5 (f)
Rat	2 weeks	Oral, gavage	4m, 4f	0, 2.5, 10, 40 (everolimus), 40 (rapamycin)	<ul style="list-style-type: none"> • ≥ 2.5 mg/kg: reduced body weight gain, food intake (m); decrease in lymphocytes, platelets and albumin; thymic atrophy; lymphoid depletion of spleen and lymph nodes; atrophy/decreased secretion of prostate and seminal vesicles; increased focal myocardial degeneration; decreased extramedullary splenic haemopoiesis; increase in alveolar

Species (strain)	Duration	Route	No./ groups	Dose (mg/kg)	Major findings
					<p>macrophages in lungs</p> <ul style="list-style-type: none"> • ≥ 10 mg/kg: reduced body weight gain, food intake (+f); increased cholesterol (m); skin lesions; bone marrow depletion (m) • 40 mg/kg: increased WBC/neutrophils; degenerative changes in testes; increased incidence of dioestrus stage. No major differences in toxicity profile compared with rapamycin • NTEL < 2.5 mg/kg
Rat	2 weeks	Oral, gavage	10m, 10f	0, 1.5, 15 (in microemulsion), 0, 1.5, 15 (in solid dispersion)	<ul style="list-style-type: none"> • No relevant differences in toxicity profile and exposure between microemulsion and solid dispersion
Rat	4 weeks (with 2 week recovery)	Oral, gavage	10m, 10f, additional 6m, 6f in recovery	0, 0.5, 1.5, 5, 15, Recovery: 0, 15	<ul style="list-style-type: none"> • ≥ 0.5 mg/kg: reduced body weight gain, food intake (m); haemo-concentration; low platelets; increased cholesterol (m); chronic myocarditis (m) • ≥ 1.5 mg/kg: reduced body weight gain, food intake (+f); increased triglycerides (f); chronic myocarditis (+f); medullary atrophy of thymus; foamy alveolar macrophages; loss of germ cells in testes; atrophy/reduced secretion of seminal vesicles; interstitial cell hypertrophy of ovaries; depletion of secretory granules in salivary glands • ≥ 5 mg/kg: Increased neutrophils; increased cholesterol (+f); low albumin; anterior suture line opacities in lens; swelling/disruption of anterior cortical lens fibres; atrophy/reduced secretion of prostate; uterus atrophy; thinning of cortical bone • 15 mg/kg: Reduced sperm counts in testes; reduced contents in epididymides. Recovery of changes except for lungs, heart, eyes and testes • NTEL approx. 0.5 mg/kg
Rat	4 weeks (with 2 week recovery)	Oral, gavage	10m, 10f, additional	0, 0.1, 0.25, 0.5, 1.5,	<ul style="list-style-type: none"> • ≥ 0.5 mg/kg: Medullary atrophy of

Species (strain)	Duration	Route	No./ groups	Dose (mg/kg)	Major findings
	week recovery)		6m, 6f in recovery	Recovery: 0, 15	<p>thymus</p> <ul style="list-style-type: none"> • 1.5 mg/kg: Reduced body weight gain, food intake; anterior suture line opacities in lens; haemo-concentration; decreased platelets; increased cholesterol (m); chronic myocarditis; increased alveolar macrophages; interstitial cell hyperplasia of ovaries; uterus atrophy; depletion of secretory granules in salivary glands. Recovery of changes except for heart • EM: Alveolar macrophages in lungs with vacuoles and multi-lamellar bodies • NTEL = 0.5 mg/kg
Rat	26 weeks (with 4 weeks recovery)	Oral, gavage	20m, 20f, additional 5m, 5f in recovery	0, 0.05, 0.1, 0.15, 0.5, 1.5, Recovery: 0, 1.5	<ul style="list-style-type: none"> • ≥ 0.15 mg/kg: reduced body weight gain (f); medullary atrophy of thymus (f) • ≥ 0.5 mg/kg: haemo-concentration (m); low platelets (m); increased amylase (m); medullary atrophy of thymus (+m); lymphoid atrophy of LN; pigment (lipofuscin) in renal tubular epithelial cells; increased hydronephrosis (m); increased alveolar macrophages and perivascular lymph. infiltration; mucus cell hypertrophy/plasia of stomach; follicular cell hypertrophy/vacuolation of thyroids (m) • 1.5 mg/kg: reduced body weight gain (+m), food intake; hemo-concentration (+f); low platelets (+f); increased neutrophils; increased cholesterol (m) and amylase (+f), decreased albumin (m) and iron; interstitial pneumonitis (m); splenic haemosiderosis; depletion of germ cells, tubular vacuolation and spermatid giant cells in testes. Recovery of changes except for lungs or testes • Special investigations on the liver drug metabolizing enzyme levels and on the overall metabolism: Minor increase in total metabolite

Species (strain)	Duration	Route	No./ groups	Dose (mg/kg)	Major findings
					<p>formation and reduction of P450 2B1/2</p> <ul style="list-style-type: none"> • NTEL = 0.15 mg/kg
Monkey	24 days	Oral, gavage	1m, 1f	1 (4d), 2 (3d), 4 (4d), 10 (3d), 20 (4d), 40 (3d) 60 (3d) 5-7 d washout after each dose of 10 and above	<ul style="list-style-type: none"> • ≥ 2 mg/kg: quietness (f) • ≥ 20 mg/kg: increased WBC • ≥ 40 mg/kg: quietness (m), piloerection and huddled posture (f) • 60 mg/kg: piloerection and huddled posture (+m); reduced lymphoid activity in thymus, spleen, LN
Monkey	2 weeks	Oral, gavage	1m, 1f	0, 5, 15, 45	<ul style="list-style-type: none"> • ≥ 5 mg/kg: piloerection, rash on chest; increased fibrinogen (m), activated partial thromboplastin time; decreased lymphoid activity in thymus, spleen and LN; sub-endocardial/interstitial haemorrhage in heart; reduced cellularity of bone marrow (f) • ≥ 15 mg/kg: quietness; increased fibrinogen (+f); subendocard./interstitial haemorrhage in heart (m) • 45 mg/kg: rough coat, huddled posture (f); body weight loss and reduced food intake; increased glucose and cholesterol (m); decreased phosphorus (m); increased globulins; sub-endocardial/interstitial haemorrhage in heart (f); reduced cellularity of bone marrow (f) • NTEL < 5 mg/kg
Monkey	4 weeks (with 2 week recovery)	Oral, gavage	3m, 3f additional 2m, 2f in recovery	0, 1.5, 5, 15 Recovery: 0, 15	<ul style="list-style-type: none"> • ≥ 1.5 mg/kg: reduced food intake (f); increased fibrinogen; decreased phosphorus; splenic lymphoid atrophy • ≥ 5 mg/kg: increase in skin lesions; reduced food intake (+m); reduced RBC parameters; increased $\alpha 2/\beta$ globulins, decreased albumin and Alb/Glob ratio (m); thymic medullary atrophy; increased histiocytosis in small intestine (f) • 15 mg/kg: pilo-erection, reddening of abdomen (m); increased WBC, neutrophils, monocytes; increased alanine and aspartate

Species (strain)	Duration	Route	No./ groups	Dose (mg/kg)	Major findings
					<p>aminotransferases; increased $\alpha 2/\beta$ globulins and decreased albumin and Alb/Glob ratio (+f); reduced urine sodium; increased histiocytosis in small intestine (+m)</p> <ul style="list-style-type: none"> • NTEL = 1.5 mg/kg
Monkey	26 weeks	Oral, gavage	4m, 4f additional 4m, 4f in control and 2m, 2f at high-dose	0, 0.1, 0.5, 1.5, 5	<ul style="list-style-type: none"> • ≥ 0.5 mg/kg: increased skin lesions (m); reduced body weight gain; splenic lymphoid atrophy; lymphoid depletion in LN; macrophage aggregation in small intestine • ≥ 1.5 mg/kg: early sacrifice (2m) in weeks 14/25 due to poor health condit.; increased skin lesions (+f); reduced food intake; reduced RBC parameters; increased neutrophils/monocytes, fibrinogen; decreased phosphorus; increased cholesterol; thymic cortical and medullary atrophy; myocardial degeneration/necrosis (1m); degranulation of pancreat. exocrine cells (m); reduced follicular development and atresia of ovaries • 5 mg/kg: early termination in weeks 9/10 due to skin lesions, poor health, body weight loss; in-creased $\alpha 2/\beta$ globulins and decreased albumin and Alb/Glob ratio; increased triglycerides, increased mucosal inflammation of large intestine; myocardial degeneration/necrosis (m); degranulation of pancreatic exocrine cells and increased islet cell degeneration; vacuolation of adrenals • Virology: coxsackievirus in plasma (including pretest) and heart tissue • NTEL = 0.5 mg/kg
Monkey	39/52 weeks	Oral, gavage	4m, 4f	0, 0.1, 0.3, 0.9	<ul style="list-style-type: none"> • ≥ 0.3 mg/kg: diarrhoea/soft faeces (m); reduced body weight/food intake (2m); increased neutrophils (f); inflammatory changes in GI tract; atrophy of testes • 0.9 mg/kg: termination after 39 weeks; 1m and 2f sacrificed early due to poor health condition

Species (strain)	Duration	Route	No./ groups	Dose (mg/kg)	Major findings
					<p>consequent to diarrhoea/soft faeces and inflammation/ ulceration of large intestine; body weight loss and reduced food intake; increased fibrinogen (f)</p> <ul style="list-style-type: none"> • NOAEL = 0.1 mg/kg
Minipig	2 weeks	Oral, gavage	1m, 1f	0, 0.5, 1.5, 5	<ul style="list-style-type: none"> • ≥ 0.5 mg/kg: decreased platelets and lymphocytes; increased creatinine (f); increased seminiferous tubular atrophy in testes; thymic cortical lymphocytolysis; decreased germinal centre activity in LN • ≥ 1.5 mg/kg: decreased albumin, γ-globulins and Alb/Glob ratio; increase in $\beta 1$ globulins • 5 mg/kg: early sacrifice (f) due to pneumonitis; increased creatinine (m)
Minipig	4 weeks (with 4 week recovery)	Oral, gavage	3m, 3f additional 2m, 2f in recovery	0, 1.5, 5, 15 Recovery: 15	<ul style="list-style-type: none"> • ≥ 1.5 mg/kg: diarrhoea related to increased coccidial infestation of intestine (m); reduced body weight gain and food intake (m); increased fibrinogen and neutrophils (m); decreased albumin and alb/glob ratio (m); decreased phosphorus, alkaline phosphatase and γ-globulins; increased $\alpha 2$ and $\beta 1$ globulins; increased percent. of β-lipoproteins and decreased percent. of chylomicrons (m); thymic atrophy; atrophy/decreased lymphoid activity in LN; myelitis and focal encephalitis (m); increased dermatitis; increased testicular tubular atrophy and oligospermia in epididymides • ≥ 5 mg/kg: lymphoid depletion of spleen (1f); necrotic follicles in uterus; microvacuolation of adrenals • 15 mg/kg: diarrhoea with one death (m)/early sacrifices (3m/1f) due to intestinal erosion with coccidial infestation; reduced body weight gain and food intake; decreased platelets (m); increased urea and creatinine (2f); decreased cholinesterase; increased LDL (LDL-3 to LDL-6) and decreased

Species (strain)	Duration	Route	No./ groups	Dose (mg/kg)	Major findings
					HDL-2a; lymphoid depletion of spleen (m); vacuolation of exocrine pancreatic cells with necrosis (m); atrophy of vagina and uterus. Recovery of all changes except for the testes. <ul style="list-style-type: none"> • NTEL < 1.5 mg/kg

Abbreviations: NTEL = no toxic effect level, NOAEL = no observed adverse effect level, m = males, f = females, + m = (f+m), + f = (m+f), EM = electronic microscopy, d = day, LN=lymph node

In summary, the major target organs were male and female reproductive systems (testicular tubular degeneration, reduced sperm content in epididymides and uterine atrophy) in several species; lungs (increased alveolar macrophages) in rats and mice; and eyes (lenticular anterior suture line opacities) in rats only. Minor kidney changes were seen in the rat (exacerbation of age-related lipofuscin in tubular epithelium, increases in hydronephrosis) and mouse (exacerbation of background lesions). There was no indication of kidney toxicity in monkeys or minipigs.

Everolimus appeared to spontaneously exacerbate background diseases (chronic myocarditis in rats, coxsackie virus infection of plasma and heart in monkeys, coccidian infestation of the gastrointestinal tract in minipigs, skin lesions in mice and monkeys). These findings were generally observed at systemic exposure levels within the range of therapeutic exposure or above, with the exception of the findings in rats, which occurred below therapeutic exposure due to a high tissue distribution.

Genotoxicity and Carcinogenicity Studies

Genotoxicity studies covering relevant genotoxicity endpoints showed no evidence of clastogenic or mutagenic activity. Administration of everolimus for up to 2 years did not indicate any oncogenic potential in mice and rats up to the highest doses, corresponding respectively to 3.9 and 0.2 times the estimated clinical exposure from a 10 mg daily dose.

Fertility, Embryofoetal Development, and Pre- and Post-natal Development Studies

In a male fertility study in rats, testicular morphology was affected at 0.5 mg/kg and above, and sperm motility, sperm head count, and plasma testosterone levels were diminished at 5 mg/kg, which is within the range of therapeutic exposure (52 ng.hr/mL and 414 ng.hr/mL respectively compared to 560 ng.hr/mL human exposure at 10 mg/day) and which caused a reduction in male fertility. There was evidence of reversibility. Female fertility was not affected, but everolimus crossed the placenta and was toxic to the conceptus. In rats, everolimus caused embryo/foetotoxicity at systemic exposure below the therapeutic level. This was manifested as mortality and reduced foetal weight. The incidence of skeletal variations and malformations (e.g. sternal cleft) was increased at 0.3 and 0.9 mg/kg. In rabbits, embryotoxicity was evident in an increase in late resorptions. The effects of everolimus on the pre- and post-natal development or

rats were limited to slightly affected body weight and survival in the F1-generation at ≥ 0.1 mg/kg, and did not indicate a specific toxic potential.

Study in Juvenile Animals

In a rat oral juvenile development study, the administration of everolimus at 0.15, 0.5 and 1.5 mg/kg on post partum days 7 to 70 with 13- and 26-week recovery periods resulted in systemic toxicity at all doses, including decreased absolute body weight gain, food consumption, delayed attainment of some developmental landmarks, with full or partial recovery after cessation of dosing. With the possible exception of the rat-specific lens finding (where young animals appeared to be more susceptible), it appears that there is no significant difference in the sensitivity of juvenile animals to the adverse effects of everolimus as compared to adult animals.

In juvenile monkeys (approximately 1 year old), the oral treatment with everolimus at dosages up to 0.5 mg/kg for 4 weeks did not cause relevant toxicity.

REFERENCES

1. Amato RJ, Jac J, Giessinger S, Saxena S, Willis JP (2009) A phase 2 study with a daily regimen of the oral mTOR inhibitor RAD001 (everolimus) in patients with metastatic clear cell renal cell cancer. *Cancer*; 115: 2438-46.
2. Amato RJ, Misellati A, Khan M, Chiang S (2006). A phase II trial of RAD001 in patients (Pts) with metastatic renal cell carcinoma (MRCC). *J Clin Oncol*; 24(18 Suppl): abstract 4530.
3. Baselga J, Campone M, Piccart M, et al (2012). Everolimus in Postmenopausal Hormone-Receptor Positive Advanced Breast Cancer. *N Engl J Med*; 366(6): 520-529
4. Bissler JJ, Kingswood JC, Radzikowska E, Zonnenberget BA, et al (2012). Everolimus for angiomyolipoma associated with tuberous sclerosis complex or sporadic lymphangiomyomatosis (EXIST-2): a multicentre, randomised, double-blind, placebo-controlled trial. www.thelancet.com Published online January 11, 2013 [http://dx.doi.org/10.1016/S0140-6736\(12\)61767-X](http://dx.doi.org/10.1016/S0140-6736(12)61767-X).
5. Bissler JJ, Kingswood JC, Radzikowska E, et al (2015). Everolimus for renal angiomyolipoma in patients with tuberous sclerosis complex or sporadic lymphangiomyomatosis: extension of a randomized controlled trial. *Nephrol Dial Transplant*; 0:1-9.
6. Boulay A, Zumstein-Mecker S, Stephan C, et al (2004). Antitumor efficacy of intermittent treatment schedules with the rapamycin derivative RAD001 correlates with prolonged inactivation of ribosomal protein S6 kinase 1 in peripheral blood mononuclear cells. *Cancer Res*; 64: 252-61.
7. Ellard SL, Clemons M, Gelmon KA, et al (2009) Randomized phase II study comparing two schedules of everolimus in patients with recurrent/metastatic breast cancer: NCIC Clinical Trials Group IND.163. *J Clin Oncol*; 27: 4536-41.
8. Escudier B, Ravaud A, Oudard S, et al (2008) Phase-3 randomised trial of everolimus (RAD001) vs placebo in metastatic renal cell carcinoma. *Ann Oncol* 2008; 19(Suppl 8): viii45 (Abstract 72O). Available at: <http://www.esmo.org/fileadmin/media/presentations/977/937/2240%20Escudier%20ESMO%202008%20Final.pptx.pdf> (last accessed 12-Nov-2009).
9. Franz DN, Belousova E, Sparagana S, et al (2014) Everolimus for subependymal giant cell astrocytoma in patients with tuberous sclerosis complex: 2-year open-label extension of the randomised EXIST-1 study. *Lancet Oncol*;15: 1513-20

10. Franz DN, Belousova E, Sparagana S, et al (2013) Efficacy and safety of everolimus for subependymal giant cell astrocytomas associated with tuberous sclerosis complex (EXIST-1): a multicentre, randomised, placebo-controlled phase 3 trial. *Lancet*; 381:125-32
11. Jac J, Amato RJ, Giessinger S, Saxena S, Willis JP (2008). A phase II study with a daily regimen of the oral mTOR inhibitor RAD001 (everolimus) in patients with metastatic renal cell carcinoma which has progressed on tyrosine kinase inhibition therapy. *J Clin Oncol*; 26(Suppl): abstract 5113.
12. Jac J, Giessinger S, Khan M, et al (2007). A phase II trial of RAD001C in patients (Pts) with metastatic renal cell carcinoma. *J Clin Oncol*; 25(18 Suppl): 261s (abstract 5107).
13. Knox J, (2008). Progression-free survival as endpoint in metastatic RCC? *Lancet*; 372: 427-9.
14. Krueger DA, Care M., Holland K, et al (2010). Everolimus for Subependymal Giant-Cell Astrocytomas in Tuberous Sclerosis. *N Engl J Med*; 363: 1801-1811.
15. Motzer RJ, Escudier B, Oudard S, et al (2008). RAD001 vs placebo in patients with metastatic renal cell carcinoma (RCC) after progression on VEGFr-TKI therapy: results from a randomized, double-blind multicenter Phase-3 study. *J Clin Oncol*; 26(Suppl): abstract LBA5026.
16. Motzer RJ, Escudier B, Oudard S, et al (2008) Efficacy of everolimus in advanced renal cell carcinoma: a double-blind, randomised, placebo-controlled phase III trial. *Lancet*; 372: 449-56.
17. O'Donnell A, Faivre S, Burris HA, et al (2008). Phase I pharmacokinetic and pharmacodynamic study of the oral mammalian target of rapamycin inhibitor everolimus in patients with advanced solid tumors. *J Clin Oncol*; 26: 1588-95.
18. Porter LL, Burris A, Jones SF, et al (2006). Summary of results in patients with metastatic renal cell cancer (RCC) for phase I studies of RAD001 (everolimus). *J Clin Oncol*; 24(18 Suppl): abstract 14599.
19. Rugo HS, Seneviratne L, Beck T, et al (2016). Prevention of everolimus-related stomatitis in women with hormone receptor-positive, HER2-negative metastatic breast cancer using dexamethasone mouthwash (SWISH): a single-arm, phase 2 trial. *Lancet Oncol* 2017. Published: 14 March 2017.
20. Tabernero J, Rojo F, Calvo E, et al (2008). **Dose-** and schedule-dependent inhibition of the mammalian target of rapamycin pathway with everolimus: a phase I tumor pharmacodynamic study in patients with advanced solid tumors. *J Clin Oncol*; 26: 1603-10.
21. Tanaka C, O'Reilly T, Kovarik JM, et al (2008). Identifying optimal biologic doses of everolimus (RAD001) in patients with cancer based on the modeling of preclinical and clinical pharmacokinetic and pharmacodynamic data. *J Clin Oncol*; 26: 1596-602.

22. Yao J, Shah M, Tetsuhide I, et al (2011). Everolimus for Advanced Pancreatic Neuroendocrine Tumors. *N Engl J Med*; 364: 514-523
23. Yao J, Fazio N, Singh S, et al (2016). Everolimus for the treatment of advanced, non-functional neuroendocrine tumours of the lung or gastrointestinal tract (RADIANT-4): a randomised, placebo-controlled, phase 3 study. *Lancet*; 5;387(10022):968-77.
24. Everolimus in advanced non-functional neuroendocrine tumors (NET) of lung or gastrointestinal (GI) origin: Efficacy and safety results from the placebo-controlled, double-blind, multicenter, Phase 3 RADIANT-4 study. Abstract ECC 2015
25. Pavel ME, Hainsworth JD, Baudin E, et al (2011). Everolimus plus octreotide long-acting repeatable for the treatment of advanced neuroendocrine tumours associated with carcinoid syndrome (RADIANT-2): a randomised, placebo-controlled, phase 3 study. www.thelancet.com Published online November 25, 2011 DOI:10.1016/S0140-6736(11)61742-X.
26. French JA, Lawson JA, Yapici Z, et al (2016). Adjunctive everolimus therapy for treatment-resistant focal-onset seizures associated with tuberous sclerosis (EXIST-3): a phase 3, randomised, double-blind, placebo-controlled study. www.thelancet.com Published online September 6, 2016 DOI:10.1016/S0140-6736(16)31419-2.

PART III: CONSUMER INFORMATION

PrAFINITOR®
(everolimus tablets)
and
PrAFINITOR® DISPERZ™
(everolimus tablets for oral suspension)

This leaflet is part III of a three-part “Product Monograph” published when AFINITOR® and AFINITOR® DISPERZ™ were approved for sale in Canada and is designed specifically for Consumers. This leaflet is a summary and will not tell you everything about AFINITOR or AFINITOR DISPERZ. Contact your doctor or pharmacist if you have any questions about the drug.

Keep this leaflet. You may need to read it again. This medicine has been prescribed only for you. Do not give it to anybody else or use it for any other illnesses.

ABOUT THIS MEDICATION

What the medication is used for:

AFINITOR is used in the treatment of:

- hormone receptor-positive, HER2-negative advanced breast cancer in postmenopausal women in whom certain other medicines (letrozole or anastrozole) no longer keep the disease under control. It is given together with a medicine called exemestane. It is not known whether AFINITOR prolongs overall survival or improves the quality of life of patients with advanced breast cancer.
- a type of pancreatic cancer known as pancreatic neuroendocrine tumour (PNET), that has progressed and cannot be treated with surgery.
- a type of cancer known as neuroendocrine tumour (NET) of gastrointestinal or lung origin that has progressed and cannot be treated with surgery.
- metastatic kidney cancer (when cancer cells have spread from the kidney to other parts of the body) after failure of treatment with sunitinib or sorafenib. It is not known whether AFINITOR prolongs overall survival or improves the quality of life of patients with kidney cancer.
- adult patients with a genetic condition called tuberous sclerosis complex (TSC) who have angiomyolipoma of the kidney (a kidney tumour) and do not require immediate surgery.

AFINITOR DISPERZ is used in the treatment of:

- seizures associated with TSC in children and adults whose seizures are not controlled well by antiepileptic medicines. AFINITOR DISPERZ is the only formulation that should be used for the treatment of patients with seizures associated with TSC.

AFINITOR and AFINITOR DISPERZ are used in the treatment of:

- patients with subependymal giant cell astrocytoma (SEGA), a brain tumour seen with a genetic condition

called tuberous sclerosis complex (TSC), who are not suitable for surgery.

What it does:

Everolimus in AFINITOR and AFINITOR DISPERZ works by blocking a specific enzyme that is involved in tumour cell growth and division. This may help to slow down the growth and spread of kidney cancer cells and of pancreatic neuroendocrine cells and may reduce the size of brain tumours (SEGA), kidney tumours (angiomyolipomas) that are associated with a genetic disorder called tuberous sclerosis complex (TSC). When given together with exemestane, everolimus in AFINITOR may slow down the growth and spread of breast cancer cells. Everolimus in AFINITOR DISPERZ may decrease the frequency of seizures in patients with TSC.

When it should not be used:

If you are allergic (hypersensitive) to everolimus, or sirolimus (RAPAMUNE®), temsirolimus (TORISEL®), or any of the other ingredients in AFINITOR or AFINITOR DISPERZ listed below in the *What the nonmedicinal ingredients are* section.

What the medicinal ingredient is:

Everolimus

What the nonmedicinal ingredients are:

AFINITOR: Butylated hydroxytoluene (E321), crospovidone, hypromellose, lactose anhydrous, lactose monohydrate and magnesium stearate.

AFINITOR DISPERZ: Butylated hydroxytoluene (E321), cellulose microcrystalline, crospovidone, hypromellose, lactose monohydrate, magnesium stearate, mannitol and silica colloidal anhydrous.

What dosage forms it comes in:

AFINITOR

AFINITOR tablets are supplied as 2.5 mg, 5 mg, 7.5 mg and 10 mg tablets that are white to slightly yellowish, elongated, with a bevelled edge and no score.

Each 2.5 mg tablet contains 2.5 mg everolimus and is engraved with “LCL” on one side and “NVR” on the other.

Each 5 mg tablet contains 5 mg everolimus and is engraved with “5” on one side and “NVR” on the other.

Each 7.5 mg tablet contains 7.5 mg everolimus and is engraved with “7P5” on one side and “NVR” on the other.

Each 10 mg tablet contains 10 mg everolimus and is engraved with “UHE” on one side and “NVR” on the other.

For 2.5 mg, 5 mg and 10 mg, each blister pack contains 10 tablets and there are 3 blister packs in a carton.

For 7.5 mg, each blister pack contains 7 tablets and there are 4

blister packs in a carton.

AFINITOR DISPERZ (for treatment of SEGA and/or seizures associated with TSC)

AFINITOR DISPERZ tablets for oral suspension are supplied as 2 mg, 3 mg and 5 mg tablets for oral suspension that are white to slightly yellowish, round, flat tablets with a bevelled edge and no score.

Each 2 mg tablet for oral suspension contains 2 mg everolimus and is engraved with “D2” on one side and “NVR” on the other.

Each 3 mg tablet for oral suspension contains 3 mg everolimus and is engraved with “D3” on one side and “NVR” on the other.

Each 5 mg tablet for oral suspension contains 5 mg everolimus and is engraved with “D5” on one side and “NVR” on the other.

Each blister pack contains 10 tablets for oral suspension and there are 3 blister packs in each carton.

BEFORE you use AFINITOR or AFINITOR DISPERZ talk to your doctor or pharmacist if you:

- have any problems with your liver or have previously had any liver disease
- have any infections. AFINITOR or AFINITOR DISPERZ can make you more likely to get an infection. Some infections have resulted in death in both adults and children.
- have had hepatitis B, because it may be reactivated during your treatment with AFINITOR or AFINITOR DISPERZ
- have diabetes (high level of sugar in the blood)
- have high cholesterol or triglyceride levels
- have low blood cell count
- are going to have surgery, if you have had a recent surgery or if you still have an unhealed wound following surgery. AFINITOR or AFINITOR DISPERZ might affect the way your wound heals.
- are pregnant, think you may be pregnant, or are planning to become pregnant. AFINITOR and AFINITOR DISPERZ are not recommended during pregnancy, as it could harm an unborn baby.
- are breastfeeding. Do not breastfeed during treatment with AFINITOR or AFINITOR DISPERZ and for two weeks after the last dose of AFINITOR or AFINITOR DISPERZ, as it could harm a breastfed baby.
- need to receive a vaccine or come in contact with those who have received a live vaccine. For paediatric patients with TSC, consider completing the recommended childhood series of live virus vaccinations prior to the start of therapy according to local treatment guidelines.
- have kidney problems as kidney failure has been reported in some patients taking AFINITOR
- are taking medication that has an effect on blood clotting or may increase the risk of bleeding, or if you have a history of bleeding disorder. Taking AFINITOR or AFINITOR DISPERZ might make your bleeding worse.
- are allergic to or suspect you are allergic to any ingredient in AFINITOR or AFINITOR DISPERZ that could result in swelling of the airways and tongue and/or difficulty in breathing.
- are taking other medicines.

Hormone receptor-positive, HER2-negative advanced breast cancer, advanced NET and metastatic kidney cancer: AFINITOR is not to be used in children or adolescents under 18 years of age.

Angiomyolipoma of the kidney associated with TSC: AFINITOR and AFINITOR DISPERZ are not to be used in children or adolescents under 18 years of age with angiomyolipoma of the kidney associated with TSC.

SEGA associated with TSC: AFINITOR and AFINITOR DISPERZ can be used in children and adolescents (below 18 years of age) who have normal liver function.

Seizures associated with TSC: AFINITOR DISPERZ can be used in patients two years of age and older who have normal liver function.

What you should know during AFINITOR or AFINITOR DISPERZ treatment

WARNINGS AND PRECAUTIONS

Serious Warnings and Precautions

Hormone receptor-positive, HER2-negative advanced breast cancer, advanced NET and metastatic kidney cancer: AFINITOR should be prescribed and managed only by a doctor experienced in anticancer drugs.

Angiomyolipoma of the kidney associated with TSC: AFINITOR tablets should be prescribed and managed only by a doctor experienced in treating patients with tuberous sclerosis complex.

The best possible duration of treatment with AFINITOR for patients with angiomyolipoma of the kidney associated with TSC is not known. Absence of menstrual periods in females who previously had periods (secondary amenorrhoea) has been observed in some female patients receiving AFINITOR and is a potential risk.

SEGA associated with TSC: AFINITOR and AFINITOR DISPERZ should be prescribed and managed only by a doctor experienced in treating patients with tuberous sclerosis complex.

The best possible duration of treatment with AFINITOR or AFINITOR DISPERZ for patients with SEGA is not known; however, SEGA re-growth has been seen once therapy is stopped.

AFINITOR or AFINITOR DISPERZ are not to be used in children and adolescents (below 18 years of age) who have liver problems.

Information available from studies in animals suggests that there is a risk of delayed development in patients taking everolimus.

AFINITOR and AFINITOR DISPERZ are **not** interchangeable. See **PROPER USE OF THIS MEDICATION**.

Serious side effects which have been reported with the use of AFINITOR include:

- Non-infectious pneumonitis (including interstitial lung disease)
- Infections
- Kidney failure

Women of child-bearing potential: AFINITOR or AFINITOR DISPERZ could harm an unborn baby or a breast-fed baby. You should use a highly effective contraceptive method during treatment with AFINITOR and for 8 weeks after treatment has stopped, even if you have not yet had a first menstrual period. Absence of periods (amenorrhoea) may develop during treatment with AFINITOR or AFINITOR DISPERZ, but pregnancy may still occur and use of a highly effective contraceptive method should continue. If you think you may have become pregnant, ask your doctor for advice. If you experience irregular or delayed periods or absence of periods (amenorrhoea) ask your doctor for advice.

Fertility: AFINITOR or AFINITOR DISPERZ may affect your ability to become pregnant or father a child (fertility). Absence of menstrual periods in females who had periods (secondary amenorrhoea) has been observed in some female patients receiving AFINITOR. Abnormal levels of reproductive hormones required for the development of sperm and absence of sperm were observed in male patients.

Monitoring during your treatment with AFINITOR or AFINITOR DISPERZ:

You will have regular blood tests during treatment. These will monitor the amount of blood cells (white blood cells, red blood cells and platelets) in your body, your kidney function (levels of creatinine, blood urea nitrogen or urinary protein), liver function (level of liver enzymes) as well as your cholesterol, triglyceride and blood sugar levels.

If you receive AFINITOR or AFINITOR DISPERZ for the treatment of SEGA, regular blood tests are necessary to measure how much everolimus is in your blood since this will help your doctor decide how much AFINITOR or AFINITOR DISPERZ you need to take.

If you receive AFINITOR DISPERZ for the treatment of seizures associated with TSC, regular blood tests are necessary to measure how much everolimus is in your blood. This will help your doctor decide how much AFINITOR DISPERZ you need to take.

INTERACTIONS WITH THIS MEDICATION

Tell your doctor or pharmacist before taking AFINITOR or AFINITOR DISPERZ if you are taking or have recently taken any other medicines, including medicines obtained without a prescription. This includes in particular:

- drugs to treat infections (antifungals like ketoconazole, itraconazole; voriconazole or fluconazole; antibiotics like clarithromycin, telithromycin or erythromycin)
- drugs to treat tuberculosis, such as rifampicin or rifabutin
- St. John's wort (also known as *Hypericum perforatum*)
- drugs to stop seizures or fits (anticonvulsants like phenytoin, carbamazepine, oxcarbazepine or phenobarbital)
- drugs to treat AIDS/HIV like ritonavir, amprenavir, fosamprenavir, efavirenz, or nevirapine
- drugs to treat heart conditions or high blood pressure (such as verapamil or diltiazem)
- angiotensin-converting enzyme (ACE) inhibitors, medicines used to treat high blood pressure or other cardiovascular problems

- a class of medications called “statins” (like atorvastatin, fluvastatin, lovastatin, pravastatin, rosuvastatin or simvastatin) to treat high levels of lipids or cholesterol in the blood
- cyclosporine, a medicine to stop the body from rejecting organ transplants
- aprepitant, a medicine to prevent nausea and vomiting
- midazolam, a medicine used to treat acute seizures, or used as a sedative before or during surgery or a medical procedure
- drugs containing pimozone, quinidine or ergotamine, as the concentration of these drugs in your blood may be affected if these drugs are taken together with AFINITOR or AFINITOR DISPERZ

For patients with SEGA who are taking anti-seizure medications, a change in anti-seizure medication dose (up or down) may require a change in AFINITOR or AFINITOR DISPERZ dose.

For patients with seizures associated with TSC who are taking anti-seizure medications, a change in anti-seizure medication dose (up or down) may require a change in AFINITOR DISPERZ dose.

While you are taking AFINITOR or AFINITOR DISPERZ you should never start a new medicine without checking first with the doctor who prescribed AFINITOR or AFINITOR DISPERZ. This includes prescribed medicines, over the counter medicines and herbal or alternative medicines.

PROPER USE OF THIS MEDICATION

AFINITOR and AFINITOR DISPERZ are not interchangeable. Make sure you are using the correct tablets prescribed for you and check with the pharmacist. Do not mix use of the two formulations. Do not switch use of the products without direction by your doctor.

Your doctor will tell you exactly how many tablets of AFINITOR or AFINITOR DISPERZ to take. Follow your doctor's instructions carefully.

AFINITOR and AFINITOR DISPERZ should be taken at about the same time each day (preferably in the morning), either consistently on an empty stomach or consistently with food.

AFINITOR

AFINITOR tablets should be taken by mouth, once daily. Swallow the tablets whole, with a glass of water. Do not chew or crush the tablets.

AFINITOR DISPERZ (for treatment of SEGA or seizures associated with TSC)

Do not chew, crush, or swallow the AFINITOR DISPERZ tablets for oral suspension. Mix AFINITOR DISPERZ in tap water or non-sparkling water only, to prepare the suspension. Do not use juice or any other liquids (see **Preparation of suspension**). Take AFINITOR DISPERZ tablets as a suspension only. You can prepare the suspension in an oral syringe or in a small drinking glass. The suspension must be taken right away. If you do not take the dose within 60 minutes after it has been prepared, throw away the dose and prepare a new dose of AFINITOR DISPERZ.

Instructions for use and handling of AFINITOR DISPERZ

Caregivers are advised to avoid contact with suspensions of AFINITOR DISPERZ. As AFINITOR DISPERZ can cause harm to an unborn baby, the suspension should be prepared, when possible, by an adult who is not pregnant or planning to become pregnant. Wash hands thoroughly before and after preparation of the suspension.

Preparation of suspension



Supplies needed to prepare the suspension in an oral syringe







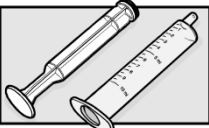
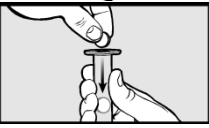

- Blister card with AFINITOR DISPERZ tablets for oral suspension
- Scissors to open the blister card
- 2 clean drinking glasses
- Approximately 30 mL of water
- 10 mL oral syringe (for one time use)



Supplies needed to prepare the suspension in a small drinking glass

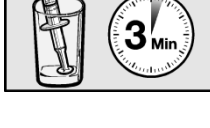
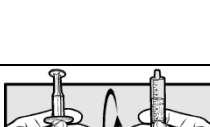
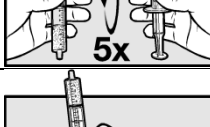

- Blister card with AFINITOR DISPERZ tablets for oral suspension
- Scissors to open the blister card
- 30 mL dose cup for measuring water (you can ask your pharmacist for this)
- 1 clean drinking glass (maximum size 100 mL)
- Water to prepare the suspension
- Spoon for stirring

Preparing a dose of AFINITOR DISPERZ suspension using an oral syringe

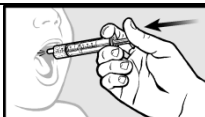
	1. Wash and dry your hands before preparing the medication.
	2. Take a 10 mL oral syringe and pull back on the plunger. Remove the plunger from the barrel of the syringe.
	3. Use scissors to open the blister card along the dotted lines. Remove the prescribed number of tablets for oral suspension from the blister card. Place the tablets for oral suspension (maximum of five 2 mg tablets, three 3 mg tablets, or two 5 mg tablets) into the oral syringe immediately.
	4. Re-insert the plunger into the barrel of the oral syringe and push the plunger until it comes into contact with the tablets for oral suspension.

	5. Fill a drinking glass with water and pull up about 5 mL of water into the oral syringe by slowly pulling back on the plunger. Note: The amount of water in the syringe does not need to be accurate. All tablets for oral suspension should be covered by water. In case tablets for oral suspension remain in the dry upper part of the syringe, make them move into the water by gentle tapping.
	6. Hold the oral syringe with the tip pointing up. Pull back on the plunger to draw back about 4 mL of air.
	7. Place the filled oral syringe in the clean, empty glass with the tip pointing up. Allow the tablets for oral suspension 3 minutes to break apart. Make sure to proceed further only when the 3 minutes are over and when the tablets for oral suspension have completely broken apart.
	8. Slowly turn the oral syringe up and down five times just before giving the dose. Do not shake the oral syringe.
	9. Hold the oral syringe in an upright position (with the tip up). Carefully remove most of the air by pushing up gently on the plunger.
	10. Give the full contents of the oral syringe slowly and gently into the mouth right away, within 60 minutes of preparing it.
	11. Carefully remove the oral syringe from patient's mouth.
	12. Insert the tip of the oral syringe into the drinking glass that is filled with water and pull up about 5 mL of water by slowly pulling back on the plunger.
	13. Hold the oral syringe with the tip pointing up and use the plunger to draw back about 4 mL of air.
	14. With the tip of the oral syringe still pointing up, swirl the contents by gently rotating the syringe in a circular manner to suspend any remaining particles of the medication.
	15. While holding the oral syringe in an upright position (with the tip up), carefully remove most of the air by pushing up gently on the plunger.







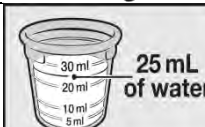

	<p>16. Dispense the full contents of the oral syringe slowly and gently into the mouth of the patient.</p> <p>17. Carefully remove the syringe from the patient's mouth. If the total prescribed dose is more than 10 mg, repeat steps 2 to 17 to finish giving the dose.</p> <p>18. Throw away the original syringe in your household trash.</p>
	<p>19. Wash your hands.</p>

finish taking the dose.	
	<p>11. Wash the glass and the spoon thoroughly with water. Wipe the glass and spoon with a clean paper towel and store them in a dry and clean place until your next dose.</p>
	<p>12. Wash your hands.</p>

Do not drink grapefruit juice or eat grapefruit, star fruit or Seville oranges. It may increase the amount of AFINITOR or AFINITOR DISPERZ in the blood, possibly to a harmful level.

Continue taking AFINITOR or AFINITOR DISPERZ as long as your doctor tells you.

Preparing a dose of AFINITOR DISPERZ suspension using a small drinking glass

	<p>1. Wash and dry your hands before preparing the medication.</p>
	<p>2. Add about 25 mL of water to the 30 mL dose cup. The amount of water added does not need to be exact.</p>
	<p>3. Pour the water from the dose cup into a small drinking glass (maximum size 100 mL).</p>
	<p>4. Use scissors to open the blister card along the dotted line and remove the prescribed number of tablets for oral suspension from the blister card.</p> <p>5. Add the prescribed number of tablets for oral suspension into the water (maximum of five 2 mg tablets, three 3-mg tablets, or two 5 mg tablets).</p>
	<p>6. Wait 3 minutes to allow the tablets for oral suspension to break apart.</p>
	<p>7. Gently stir the contents of the glass with a spoon.</p>
	<p>8. Drink the full amount of the suspension right away, within 60 minutes of preparing it.</p>
	<p>9. Refill the glass with the same amount of water (about 25 mL). Stir the contents with the same spoon.</p>
	<p>10. Drink the full amount right away so that you take any remaining medicine. If the total prescribed dose is more than 10 mg, repeat steps 2 to 10 to</p>

Usual dose:

Hormone receptor-positive, HER2-negative advanced breast cancer, NET, metastatic kidney cancer and angiomyolipoma of the kidney associated with TSC: The usual dose is 10 mg, to be taken by mouth once daily, at about the same time each day (preferably in the morning). AFINITOR should be taken either consistently with food or consistently without food.

A higher or lower dose may be recommended by your doctor based on your individual treatment needs (e.g. if you have liver problems or if you are taking certain additional medicines).

SEGA associated with TSC: Your doctor will determine the starting dose of AFINITOR or AFINITOR DISPERZ you need to take depending on your body size, the health of your liver and other medicines you are taking. Blood tests are necessary during treatment with AFINITOR or AFINITOR DISPERZ to measure the amount of everolimus in your blood and find the best daily dose for you.

Your doctor might need to reduce your dose of AFINITOR or AFINITOR DISPERZ, or to interrupt or discontinue your treatment with AFINITOR or AFINITOR DISPERZ (e.g., if you have lung or breathing problems, mouth ulcers).

Seizures associated with TSC: Your doctor will determine the starting dose of AFINITOR DISPERZ you need to take depending on your body size, the health of your liver and other medicines you are taking. Blood tests are necessary during treatment with AFINITOR DISPERZ to measure the amount of everolimus in your blood and find the best daily dose for you.

Your doctor might need to reduce your dose of AFINITOR DISPERZ, or to interrupt or discontinue your treatment with AFINITOR DISPERZ for a variety of reasons. For example, if you have lung or breathing problems, mouth sores/ulcers, etc.

Overdose:

In case of drug overdose, contact a health care practitioner, hospital emergency department or regional Poison Control Centre immediately, even if there are no symptoms.

Missed Dose:

If you forget to take AFINITOR or AFINITOR DISPERZ, you may still take it up to 6 hours after the time you normally take it.

If you remember more than 6 hours after you normally take your AFINITOR or AFINITOR DISPERZ, skip the dose for that day. The next day, take AFINITOR or AFINITOR DISPERZ at your usual time. Do not take a double dose to make up for the one that you missed.

SIDE EFFECTS AND WHAT TO DO ABOUT THEM

Like all medicines, AFINITOR and AFINITOR DISPERZ can cause side effects.

Treatment of hormone receptor-positive, HER2-negative advanced breast cancer, advanced NET and metastatic kidney cancer

Very common side effects:

These side effects may affect more than 1 in 10 patients.

- Lung or breathing problems (pneumonitis)
- Infections
- Loss of appetite
- Disturbed taste (dysgeusia)
- Dry mouth
- Headache
- Cough
- Nose bleeds (epistaxis)
- Breathlessness (dyspnoea)
- Dizziness
- Mouth ulcers: AFINITOR can cause mouth ulcers and sores. Your doctor may tell you to use a special mouthwash or mouth gel that does not contain alcohol or peroxide that may require a prescription. **Tell your doctor** if you have pain, discomfort, or open sores in the mouth.
- Stomach upsets like feeling sick (nausea), being sick (vomiting), diarrhoea, constipation
- Hair loss
- Rash
- Dry skin
- Itching (pruritus)
- Nail disorders
- Feeling weak or tired
- Mucosal inflammation
- Swelling of arms, hands, feet, ankles, face or other part of the body (signs of oedema)
- Fever
- Loss of weight
- Low red blood cell count (anaemia)
- High blood glucose
- High cholesterol
- High triglycerides
- High blood pressure
- Low level of potassium in the blood (hypokalaemia)
- High level of phosphate in the blood
- Pain in arm and leg, mouth and throat, back or joints
- Trouble sleeping (insomnia)

If any of these affects you severely, **tell your doctor.**

Common side effects:

These side effects may affect between 1 and 10 in every 100 patients.

- Blockade or obstruction of a blood vessel (vein) in the legs (deep vein thrombosis). Symptoms may be swelling and/or pain in one of your legs, usually your calf, and redness or warm skin in the affected area.
- Chest pain, cough, hiccups and rapid breathing (signs of fluid collection between the layers of tissue that line the lungs and chest cavity)
- High level of sugar in the blood (diabetes)
- Worsening of diabetes
- Dehydration
- Pulmonary embolism (a condition that occurs when one or more arteries in your lungs become blocked). Symptoms may be sudden onset of shortness of breath, chest pain or coughing up blood). **Talk to your doctor right away if this occurs.**
- Coughing up blood (haemoptysis)
- Heartburn (dyspepsia)
- Difficulty in swallowing (dysphagia)
- Acne
- Rash/pain on the palms of your hands or soles of your feet (hand foot syndrome)
- Skin reddening (erythema)
- Protein in the urine
- Kidney failure
- Pain in abdomen, chest or jaw
- Low lymphocyte, platelet or white blood cell count
- Excess fluid around lung
- Haemorrhoids or bleeding
- Low blood phosphate or calcium
- Tingling sensation/feeling of numbness
- Muscle spasm
- Chills
- Swelling of eyelids
- Runny nose
- High level of liver enzymes
- Heart problems, tachycardia or rapid heartbeat, heart failure (breathlessness, difficulty breathing when lying down, swelling of the feet or legs)
- Pink eye
- Swelling of gums (gingivitis)
- Feeling depressed
- Loss of taste (ageusia)

If any of these affects you severely, **tell your doctor.**

Uncommon side effects:

These side effects may affect between 1 and 10 in every 1,000 patients.

- A type of anaemia called pure red cell aplasia
- Onset of diabetes
- Abnormal wound healing
- Absence of menstrual periods (amenorrhoea)
- Loss of hearing

If any of these affects you severely, **tell your doctor**.

Treatment of angiomyolipoma of the kidney associated with TSC

Very common side effects:

These side effects may affect more than 1 in 10 patients.

- Low level of red blood cells (anaemia)
- Low level of white blood cells (leukopenia)
- High level of cholesterol in the blood (hypercholesterolaemia)
- Mouth ulcers. AFINITOR® can cause mouth ulcers and sores. **Tell your doctor** if you have pain, discomfort, or open sores in your mouth. You might need treatment with a mouthwash or gel. Some mouthwashes and gels can make ulcers worse, so do not try anything without checking with your doctor first.
- Middle ear infection
- Stomach upsets like feeling sick (nausea)
- Being sick (vomiting)
- Diarrhoea
- Abdominal pain
- Swelling of arms, hands, feet, ankles or other part of the body (signs of oedema)
- Upper respiratory tract infection
- Acne
- Skin rash
- Itchy rash (eczema)
- High level of an enzyme, called blood lactate dehydrogenase, in the blood that gives information about the health of certain organs
- Low level of phosphate in the blood (hypophosphatemia)
- Joint pain
- Headache
- Cough
- Menstruation disorders such as absence of periods (amenorrhoea), irregular periods, heavy periods (menorrhagia)

Common side effects:

These side effects may affect between 1 and 10 in every 100 patients.

- Rash, itching, hives, difficulty breathing or swallowing, dizziness, signs of serious allergic reaction (hypersensitivity)
- Menstruation disorders such as vaginal bleeds, delayed periods, or infrequent periods (oligomenorrhoea)
- Rash with pus-filled blister
- Rash with small, fluid-filled blisters on the mouth (mouth herpes)
- Fever, coughing, difficulty breathing, wheezing, signs of inflammation of the lung (pneumonia)
- Inflammation of the sinuses and nasal passages (sinusitis). Symptoms may include headache, pressure in the eyes, nose or cheek area
- Low level of platelets (thrombocytopenia)
- A special lung functional test result decreased (carbon monoxide test)

- High level of an enzyme called blood alkaline phosphatase, in the blood that gives information about the health of certain organs
- High level of an enzyme, called blood gamma-glutamyltransferase, in the blood that gives information about the health of your liver
- High level of lipids in the blood (hyperlipidaemia)
- Decreased appetite
- Low level of iron (iron deficiency)
- Severe headache often accompanied by nausea, vomiting and sensitivity to light (migraine)
- Disturbed taste (dysgeusia)
- Loss of taste (ageusia)
- Nose bleeds (epistaxis)
- Excess amount of gas in the bowels (flatulence)
- An inflammatory condition of the skin characterized by redness, itching, and oozing liquid-filled cysts which become scaly, crusted, or hardened (dermatitis acneiform)
- Dry skin
- Fever, coughing, difficulty breathing, wheezing, signs of inflammation of the lung (pneumonitis)
- Feeling depressed
- Sudden, severe increase in blood pressure
- Inability to sleep (insomnia)
- Aggression
- Mouth pain
- Higher level of ovulation triggering hormone (blood luteinising hormone increased)
- Higher level of female reproductive hormone (blood follicle stimulating hormone increased)
- Swollen, bleeding gums, signs of gum inflammation (gingivitis)
- Bad pain in the lower abdomen and pelvic area that may be sharp, with menstrual irregularities (ovarian cyst)

If any of these affects you severely, **tell your doctor**.

Treatment of SEGA associated with TSC

Very common side effects:

These side effects may affect more than 1 in 10 patients.

- Infections, such as inflammation of the sinuses and nasal passages (sinusitis), middle or outer ear infection, gastric infection, sore throat and runny nose, skin infections, ringworm (a fungus infection of the skin), infections of the hair follicle, urinary tract infection, conjunctivitis, upper respiratory tract infection, pneumonia.
- Mouth ulcers: AFINITOR® can cause mouth ulcers and sores. **Tell your doctor** if you have pain, discomfort, or open sores in the mouth. Your doctor may tell you to use a special mouthwash or mouth gel that does not contain alcohol or peroxide.
- High level of cholesterol in the blood
- High levels of fats in the blood (raised triglycerides)
- Cough
- Diarrhoea and constipation
- Skin problems (such as rash, acne, dry skin or scratching of the skin)

- Fever
- Low white blood cells (a type of blood cell that fights infections; your doctor will check periodically)
- Vomiting
- Stomach pain
- Seizure
- Headache
- Dizziness
- Stuffy or runny nose
- Change in personality
- Loss of appetite
- High level of sugar in the blood (hyperglycemia)
- High blood pressure (hypertension)
- Sore throat and runny nose (nasopharyngitis)

If any of these affects you severely, **tell your doctor**.

Common side effects:

These side effects may affect between 1 and 10 in every 100 patients.

- Abscess of limb
- Bronchitis viral
- Low level of red blood cells (anaemia)
- Aggression
- Inability to sleep (insomnia)
- Feeling agitated
- Fits (convulsions)
- Nose bleeds
- Throat inflammation
- Inflammation of the stomach lining (gastritis)
- A pink itchy rash on your body called pityriasis rosea
- Protein in the urine
- Menstruation disorders, such as absence of periods (amenorrhoea), irregular periods
- Feeling tired
- Irritability
- Trouble walking (gait disturbance)
- Decrease antibody levels in the blood (ask your doctor)
- Increased low density lipoprotein in the blood
- Pain in the mouth
- Pain in the mouth or throat
- Rash of small fluid-filled blisters, appearing on reddened skin, signs of viral infection that can be potentially severe (herpes zoster)
- Higher level of ovulation triggering hormone (blood luteinising hormone increased)
- Urinary tract infection
- Swollen, bleeding gums, signs of gum inflammation (gingivitis)
- Weight loss
- Abnormal kidney function test results
- Abdominal pain
- Decrease of a special protein (fibrinogen) that helps blood clot
- Bacterial skin infection
- Absence of sperms

If any of these affects you severely, **tell your doctor**.

Treatment of seizures associated with TSC:

Very common side effects:

- Mouth ulcers. AFINITOR® can cause mouth ulcers and sores. Tell your doctor if you have pain, discomfort, or open sores in your mouth. You might need treatment with a mouthwash or gel. Some mouthwashes and gels can make ulcers worse, so do not try anything without checking with your doctor first
- Diarrhoea
- Throwing up (vomiting)
- Sore throat and runny nose (nasopharyngitis)
- Upper respiratory tract infection
- Fever
- Cough
- Low level of white blood cells which help fight infections (leukopenia, lymphopenia, neutropenia). This could increase chances of contracting different types of infection.
- Low level of red blood cells (anaemia)
- Low level of blood cells called platelets (thrombocytopenia) which are responsible to control bleeding. This could increase risk of bleeding.
- High level of fat called cholesterol in the blood (hypercholesterolaemia)
- High level of fats in the blood called triglycerides (Hypertriglyceridemia)
- Increased levels of enzymes liver enzymes in the blood which give information about health of liver.
- High level of sugar in the blood (hyperglycemia)
- High level of an enzyme called alkaline phosphatase, in the blood that gives information about the health of certain organs mainly liver and bones.

Common side effects:

- Rash
- Constipation
- Feeling sick (nausea)
- Gas in the stomach and bowels (flatulence)
- Inflammation of the stomach lining (gastritis)
- Abdominal pain
- Feeling tired
- Sore throat (pharyngitis)
- Inflammation of the tissue in one or both lungs (pneumonia), with cough, fever and difficulty in breathing
- Inflammation of the lining of the sinuses (hollow spaces in the bones of the face around nose) (sinusitis)
- Urinary tract infection
- Infection of stomach and intestines by a virus (gastroenteritis and intestinal flu)
- Inflammation and swelling of gums(gingivitis)
- Ear infection
- Skin inflammation (cellulitis)
- High level of an enzyme, called blood lactate dehydrogenase, in the blood that gives information about the health of certain organs

- Higher level of ovulation triggering hormone (blood luteinising hormone increased)
- Decreased appetite
- Headache
- Irritability
- Aggression
- Inability to sleep (insomnia)
- Protein in the urine
- Absence of periods (amenorrhoea) or irregular periods or heavy periods (menorrhagia)
- Nose bleeds (epistaxis)
- Fever, coughing, difficulty breathing, wheezing, signs of inflammation of the lung (pneumonitis)
- Acne
- Dry skin
- High blood pressure (hypertension)
- Low level of a chemical called phosphate in the blood (hypophosphatemia), which is responsible for health of bones, teeth and muscles.

If any of these affects you severely, **tell your doctor.**

SERIOUS SIDE EFFECTS, HOW OFTEN THEY HAPPEN AND WHAT TO DO ABOUT THEM				
Symptom / effect		Talk with your doctor or pharmacist		Stop taking drug and call your doctor or pharmacist
		Only if severe	In all cases	
Very common	Pain, discomfort or sores in the mouth		√	
Common	Lung or breathing problems (pneumonitis, pulmonary embolism, acute respiratory syndrome) (cough, chest pain, shortness of breath)		√	
	Fever or chills or other signs of an infection as you might need urgent treatment		√	
	Increased frequency in urination; kidney failure		√	

SERIOUS SIDE EFFECTS, HOW OFTEN THEY HAPPEN AND WHAT TO DO ABOUT THEM			
Symptom / effect	Talk with your doctor or pharmacist		Stop taking drug and call your doctor or pharmacist
	Only if severe	In all cases	
Rash, itching, hives, difficulty breathing or swallowing, dizziness, signs of serious allergic reaction (swelling of the face, lips, tongue or throat) (hypersensitivity)			√
Coughing up blood			√
Uncommon	Swelling and/or pain, and redness or warm skin in your leg, usually affecting the calf (deep vein thrombosis)		√
	Blood in urine		√
	Unexpected vaginal bleeding		√
	Severe abdominal pain, vomiting blood, black or bloody stools, swelling of the abdomen, constipation (gastrointestinal bleeding)		√
	Hepatitis B reactivation with symptoms of fever, skin rash, joint pain and inflammation, tiredness, loss of appetite, nausea, yellowing of the skin, pain in the upper abdomen, pale stool or dark urine		√
	Swelling of the airways or tongue, with or without respiratory impairment (angioedema)		√

SERIOUS SIDE EFFECTS, HOW OFTEN THEY HAPPEN AND WHAT TO DO ABOUT THEM

Symptom / effect	Talk with your doctor or pharmacist		Stop taking drug and call your doctor or pharmacist
	Only if severe	In all cases	
Fever, chills, rapid breathing and heart rate, rash, and possibly confusion and disorientation (signs of serious infection, also known as sepsis)		√	
Reported from post-marketing with unknown frequency			√
Severe headache, weakness or paralysis of limbs or face, difficulty speaking, sudden loss of consciousness (bleeding in the brain)			
Muscle pain, tenderness and weakness that you cannot explain		√	
Brownish or discoloured urine			√

This is not a complete list of side effects. For any unexpected effects while taking AFINITOR or AFINITOR DISPERZ, contact your doctor or pharmacist.

HOW TO STORE IT

Do not use after the expiry date shown on the box.

Store at room temperature (15–30°C). Store in the original package to protect from light and moisture.

Keep out of the reach and sight of children and pets.

You can report any suspected adverse reactions associated with the use of health products to the Canada Vigilance Program by one of the following 3 ways:

- Report online at www.healthcanada.gc.ca/medeffect
- Call toll-free at 1-866-234-2345
- Complete a Canada Vigilance Reporting Form and:
 - Fax toll-free to 1-866-678-6789, or
 - Mail to: Canada Vigilance Program

Health Canada
Postal Locator 1908C
Ottawa, ON K1A 0K9

Postage paid labels, Canada Vigilance Reporting Form and the adverse reaction reporting guidelines are available on the MedEffect™ Canada Web site at www.healthcanada.gc.ca/medeffect.

NOTE: Should you require information related to the management of side effects, contact your health professional. The Canada Vigilance Program does not provide medical advice.

MORE INFORMATION

This document plus the full product monograph, prepared for health professionals can be found at: <http://www.novartis.ca>

or by contacting the sponsor, Novartis Pharmaceuticals Canada Inc. at: 1-800-363-8883

This leaflet was prepared by, Novartis Pharmaceuticals Canada Inc. 385 Bouchard Blvd. Dorval, Quebec, H9S 1A9

Last revised: November 16, 2017

AFINITOR, AFINITOR DISPERZ and SANDOSTATIN LAR are registered trademarks of Novartis Pharmaceuticals Canada Inc. RAPAMUNE and TORISEL are registered trademarks of Pfizer Canada Inc.

HIGHLIGHTS OF PRESCRIBING INFORMATION

These highlights do not include all the information needed to use AFINITOR/AFINITOR DISPERZ safely and effectively. See full prescribing information for AFINITOR/AFINITOR DISPERZ.

AFINITOR® (everolimus) tablets, for oral use

AFINITOR DISPERZ® (everolimus tablets for oral suspension)

Initial U.S. Approval: 2009

RECENT MAJOR CHANGES

Warnings and Precautions, Risk of Impaired Wound Healing (5.7) 2/2020

INDICATIONS AND USAGE

AFINITOR is a kinase inhibitor indicated for the treatment of:

- Postmenopausal women with advanced hormone receptor-positive, HER2-negative breast cancer in combination with exemestane after failure of treatment with letrozole or anastrozole. (1.1)
- Adults with progressive neuroendocrine tumors of pancreatic origin (PNET) and adults with progressive, well-differentiated, non-functional neuroendocrine tumors (NET) of gastrointestinal (GI) or lung origin that are unresectable, locally advanced or metastatic.
Limitations of Use: AFINITOR is not indicated for the treatment of patients with functional carcinoid tumors. (1.2)
- Adults with advanced renal cell carcinoma (RCC) after failure of treatment with sunitinib or sorafenib. (1.3)
- Adults with renal angiomyolipoma and tuberous sclerosis complex (TSC), not requiring immediate surgery. (1.4)

AFINITOR and AFINITOR DISPERZ are kinase inhibitors indicated for the treatment of adult and pediatric patients aged 1 year and older with TSC who have subependymal giant cell astrocytoma (SEGA) that requires therapeutic intervention but cannot be curatively resected. (1.5)

AFINITOR DISPERZ is a kinase inhibitor indicated for the adjunctive treatment of adult and pediatric patients aged 2 years and older with TSC-associated partial-onset seizures. (1.6)

DOSAGE AND ADMINISTRATION

Do not combine AFINITOR and AFINITOR DISPERZ to achieve the total daily dose. (2.1)

Modify the dose for patients with hepatic impairment or for patients taking drugs that inhibit or induce P-glycoprotein (P-gp) and CYP3A4. (2.1)

Breast Cancer:

- 10 mg orally once daily. (2.2)

NET:

- 10 mg orally once daily. (2.3)

RCC:

- 10 mg orally once daily. (2.4)

TSC-Associated Renal Angiomyolipoma:

- 10 mg orally once daily. (2.5)

TSC-Associated SEGA:

- 4.5 mg/m² orally once daily; adjust dose to attain trough concentrations of 5-15 ng/mL. (2.6, 2.8)

TSC-Associated Partial-Onset Seizures:

- 5 mg/m² orally once daily; adjust dose to attain trough concentrations of 5-15 ng/mL. (2.7, 2.8)

DOSAGE FORMS AND STRENGTHS

- AFINITOR: 2.5 mg, 5 mg, 7.5 mg, and 10 mg tablets (3)
- AFINITOR DISPERZ: 2 mg, 3 mg, and 5 mg tablets (3)

CONTRAINDICATIONS

Clinically significant hypersensitivity to everolimus or to other rapamycin derivatives. (4)

WARNINGS AND PRECAUTIONS

- Non-Infectious Pneumonitis: Monitor for clinical symptoms or radiological changes. Withhold or permanently discontinue based on severity. (2.9, 5.1)
- Infections: Monitor for signs and symptoms of infection. Withhold or permanently discontinue based on severity. (2.9, 5.2)
- Severe Hypersensitivity Reactions: Permanently discontinue for clinically significant hypersensitivity. (5.3)
- Angioedema: Patients taking concomitant angiotensin-converting-enzyme (ACE) inhibitors may be at increased risk for angioedema. Permanently discontinue for angioedema. (5.4, 7.2)
- Stomatitis: Initiate dexamethasone alcohol-free mouthwash when starting treatment. (5.5, 6.1)
- Renal Failure: Monitor renal function prior to treatment and periodically thereafter. (5.6)
- Risk of Impaired Wound Healing: Withhold for at least 1 week prior to elective surgery. Do not administer for at least 2 weeks following major surgery and until adequate wound healing. The safety of resumption of treatment after resolution of wound healing complications has not been established. (5.7)
- Geriatric Patients: Monitor and adjust dose for adverse reactions. (5.8)
- Metabolic Disorders: Monitor serum glucose and lipids prior to treatment and periodically thereafter. Withhold or permanently discontinue based on severity (2.9, 5.9)
- Myelosuppression: Monitor hematologic parameters prior to treatment and periodically thereafter. Withhold or permanently discontinue based on severity. (2.9, 5.10)
- Risk of Infection or Reduced Immune Response with Vaccination: Avoid live vaccines and close contact with those who have received live vaccines. Complete recommended childhood vaccinations prior to starting treatment. (5.11)
- Embryo-Fetal Toxicity: Can cause fetal harm. Advise patients of reproductive potential of the potential risk to a fetus and to use effective contraception. (5.12, 8.1, 8.3)

ADVERSE REACTIONS

- Breast cancer, NET, RCC: Most common adverse reactions (incidence ≥ 30%) include stomatitis, infections, rash, fatigue, diarrhea, edema, abdominal pain, nausea, fever, asthenia, cough, headache, and decreased appetite. (6.1)
- TSC-Associated Renal Angiomyolipoma: Most common adverse reaction (incidence ≥ 30%) is stomatitis. (6.1)
- TSC-Associated SEGA: Most common adverse reactions (incidence ≥ 30%) are stomatitis and respiratory tract infection. (6.1)
- TSC-Associated Partial-Onset Seizures: Most common adverse reaction (incidence ≥ 30%) is stomatitis. (6.1)

To report SUSPECTED ADVERSE REACTIONS, contact Novartis Pharmaceuticals Corporation at 1-888-669-6682 or FDA at 1-800-FDA-1088 or www.fda.gov/medwatch.

DRUG INTERACTIONS

- P-gp and strong CYP3A4 inhibitors: Avoid concomitant use. (2.11, 7.1)
- P-gp and moderate CYP3A4 inhibitors: Reduce the dose as recommended. (2.11, 7.1)
- P-gp and strong CYP3A4 inducers: Increase the dose as recommended. (2.12, 7.1)

USE IN SPECIFIC POPULATIONS

- For breast cancer, NET, RCC, or TSC-associated renal angiomyolipoma patients with hepatic impairment, reduce the dose. (2.10, 8.6)
- For patients with TSC-associated SEGA or TSC-associated partial-onset seizures and severe hepatic impairment, reduce the starting dose and adjust dose to attain target trough concentrations. (2.8, 2.10, 8.6)

See 17 for PATIENT COUNSELING INFORMATION and FDA-approved patient labeling.

Revised: 2/2020

FULL PRESCRIBING INFORMATION: CONTENTS***1 INDICATIONS AND USAGE**

- 1.1 Hormone Receptor-Positive, HER2-Negative Breast Cancer
- 1.2 Neuroendocrine Tumors (NET)
- 1.3 Renal Cell Carcinoma (RCC)
- 1.4 Tuberous Sclerosis Complex (TSC)-Associated Renal Angiomyolipoma
- 1.5 Tuberous Sclerosis Complex (TSC)-Associated Subependymal Giant Cell Astrocytoma (SEGA)
- 1.6 Tuberous Sclerosis Complex (TSC)-Associated Partial-Onset Seizures

2 DOSAGE AND ADMINISTRATION

- 2.1 Important Dosage Information
- 2.2 Recommended Dosage for Hormone Receptor-Positive, HER2-Negative Breast Cancer
- 2.3 Recommended Dosage for Neuroendocrine Tumors (NET)
- 2.4 Recommended Dosage for Renal Cell Carcinoma (RCC)
- 2.5 Recommended Dosage for Tuberous Sclerosis Complex (TSC)-Associated Renal Angiomyolipoma
- 2.6 Recommended Dosage for Tuberous Sclerosis Complex (TSC)-Associated Subependymal Giant Cell Astrocytoma (SEGA)
- 2.7 Recommended Dosage for Tuberous Sclerosis Complex (TSC)-Associated Partial-Onset Seizures
- 2.8 Therapeutic Drug Monitoring (TDM) and Dose Titration for Tuberous Sclerosis Complex (TSC)-Associated Subependymal Giant Cell Astrocytoma (SEGA) and TSC-Associated Partial-Onset Seizures
- 2.9 Dosage Modifications for Adverse Reactions
- 2.10 Dosage Modifications for Hepatic Impairment
- 2.11 Dosage Modifications for P-gp and CYP3A4 Inhibitors
- 2.12 Dosage Modifications for P-gp and CYP3A4 Inducers
- 2.13 Administration and Preparation

3 DOSAGE FORMS AND STRENGTHS**4 CONTRAINDICATIONS****5 WARNINGS AND PRECAUTIONS**

- 5.1 Non-infectious Pneumonitis
- 5.2 Infections
- 5.3 Severe Hypersensitivity Reactions
- 5.4 Angioedema with Concomitant Use of Angiotensin-Converting Enzyme (ACE) Inhibitors
- 5.5 Stomatitis
- 5.6 Renal Failure
- 5.7 Risk of Impaired Wound Healing

- 5.8 Geriatric Patients
- 5.9 Metabolic Disorders
- 5.10 Myelosuppression
- 5.11 Risk of Infection or Reduced Immune Response with Vaccination
- 5.12 Embryo-Fetal Toxicity

6 ADVERSE REACTIONS

- 6.1 Clinical Trials Experience
- 6.2 Postmarketing Experience

7 DRUG INTERACTIONS

- 7.1 Effect of Other Drugs on AFINITOR/AFINITOR DISPERZ
- 7.2 Effects of Combination Use of Angiotensin Converting Enzyme (ACE) Inhibitors

8 USE IN SPECIFIC POPULATIONS

- 8.1 Pregnancy
- 8.2 Lactation
- 8.3 Females and Males of Reproductive Potential
- 8.4 Pediatric Use
- 8.5 Geriatric Use
- 8.6 Hepatic Impairment

11 DESCRIPTION**12 CLINICAL PHARMACOLOGY**

- 12.1 Mechanism of Action
- 12.2 Pharmacodynamics
- 12.3 Pharmacokinetics

13 NONCLINICAL TOXICOLOGY

- 13.1 Carcinogenesis, Mutagenesis, Impairment of Fertility
- 13.2 Animal Toxicology and/or Pharmacology

14 CLINICAL STUDIES

- 14.1 Hormone Receptor-Positive, HER2-Negative Breast Cancer
- 14.2 Neuroendocrine Tumors (NET)
- 14.3 Renal Cell Carcinoma (RCC)
- 14.4 Tuberous Sclerosis Complex (TSC)-Associated Renal Angiomyolipoma
- 14.5 Tuberous Sclerosis Complex (TSC)-Associated Subependymal Giant Cell Astrocytoma (SEGA)
- 14.6 Tuberous Sclerosis Complex (TSC)-Associated Partial-Onset Seizures

15 REFERENCES**16 HOW SUPPLIED/STORAGE AND HANDLING****17 PATIENT COUNSELING INFORMATION**

*Sections or subsections omitted from the full prescribing information are not listed

FULL PRESCRIBING INFORMATION

1 INDICATIONS AND USAGE

1.1 Hormone Receptor-Positive, HER2-Negative Breast Cancer

AFINITOR® is indicated for the treatment of postmenopausal women with advanced hormone receptor-positive, HER2-negative breast cancer in combination with exemestane, after failure of treatment with letrozole or anastrozole.

1.2 Neuroendocrine Tumors (NET)

AFINITOR is indicated for the treatment of adult patients with progressive neuroendocrine tumors of pancreatic origin (PNET) with unresectable, locally advanced or metastatic disease.

AFINITOR is indicated for the treatment of adult patients with progressive, well-differentiated, non-functional NET of gastrointestinal (GI) or lung origin with unresectable, locally advanced or metastatic disease.

Limitations of Use: AFINITOR is not indicated for the treatment of patients with functional carcinoid tumors [*see Clinical Studies (14.2)*].

1.3 Renal Cell Carcinoma (RCC)

AFINITOR is indicated for the treatment of adult patients with advanced RCC after failure of treatment with sunitinib or sorafenib.

1.4 Tuberos Sclerosis Complex (TSC)-Associated Renal Angiomyolipoma

AFINITOR is indicated for the treatment of adult patients with renal angiomyolipoma and TSC, not requiring immediate surgery.

1.5 Tuberos Sclerosis Complex (TSC)-Associated Subependymal Giant Cell Astrocytoma (SEGA)

AFINITOR and AFINITOR DISPERZ® are indicated in adult and pediatric patients aged 1 year and older with TSC for the treatment of SEGA that requires therapeutic intervention but cannot be curatively resected.

1.6 Tuberos Sclerosis Complex (TSC)-Associated Partial-Onset Seizures

AFINITOR DISPERZ is indicated for the adjunctive treatment of adult and pediatric patients aged 2 years and older with TSC-associated partial-onset seizures.

2 DOSAGE AND ADMINISTRATION

2.1 Important Dosage Information

- AFINITOR and AFINITOR DISPERZ are two different dosage forms. Select the recommended dosage form based on the indication [*see Indications and Usage (1)*]. Do not combine AFINITOR and AFINITOR DISPERZ to achieve the total dose.
- Modify the dosage for patients with hepatic impairment or for patients taking drugs that inhibit or induce P-glycoprotein (P-gp) and CYP3A4 [*see Dosage and Administration (2.10, 2.11, 2.12)*].

2.2 Recommended Dosage for Hormone Receptor-Positive, HER2-Negative Breast Cancer

The recommended dosage of AFINITOR is 10 mg orally once daily until disease progression or unacceptable toxicity.

2.3 Recommended Dosage for Neuroendocrine Tumors (NET)

The recommended dosage of AFINITOR is 10 mg orally once daily until disease progression or unacceptable toxicity.

2.4 Recommended Dosage for Renal Cell Carcinoma (RCC)

The recommended dosage of AFINITOR is 10 mg orally once daily until disease progression or unacceptable toxicity.

2.5 Recommended Dosage for Tuberous Sclerosis Complex (TSC)-Associated Renal Angiomyolipoma

The recommended dosage of AFINITOR is 10 mg orally once daily until disease progression or unacceptable toxicity.

2.6 Recommended Dosage for Tuberous Sclerosis Complex (TSC)-Associated Subependymal Giant Cell Astrocytoma (SEGA)

The recommended starting dosage of AFINITOR/AFINITOR DISPERZ is 4.5 mg/m² orally once daily until disease progression or unacceptable toxicity [see *Dosage and Administration* (2.8)].

2.7 Recommended Dosage for Tuberous Sclerosis Complex (TSC)-Associated Partial-Onset Seizures

The recommended starting dosage of AFINITOR DISPERZ is 5 mg/m² orally once daily until disease progression or unacceptable toxicity [see *Dosage and Administration* (2.8)].

2.8 Therapeutic Drug Monitoring (TDM) and Dose Titration for Tuberous Sclerosis Complex (TSC)-Associated Subependymal Giant Cell Astrocytoma (SEGA) and TSC-Associated Partial-Onset Seizures

- Monitor everolimus whole blood trough concentrations at time points recommended in Table 1.
- Titrate the dose to attain trough concentrations of 5 ng/mL to 15 ng/mL.
- Adjust the dose using the following equation:

$$\text{New dose}^* = \text{current dose} \times (\text{target concentration} / \text{current concentration})$$

*The maximum dose increment at any titration must not exceed 5 mg. Multiple dose titrations may be required to attain the target trough concentration.

- When possible, use the same assay and laboratory for TDM throughout treatment.

Table 1: Recommended Timing of Therapeutic Drug Monitoring

Event	When to Assess Trough Concentrations After Event
Initiation of AFINITOR/AFINITOR DISPERZ	1 to 2 weeks
Modification of AFINITOR/AFINITOR DISPERZ dose	1 to 2 weeks
Switch between AFINITOR and AFINITOR DISPERZ	1 to 2 weeks
Initiation or discontinuation of P-gp and moderate CYP3A4 inhibitor	2 weeks
Initiation or discontinuation of P-gp and strong CYP3A4 inducer	2 weeks
Change in hepatic function	2 weeks
Stable dose with changing body surface area (BSA)	Every 3 to 6 months
Stable dose with stable BSA	Every 6 to 12 months

Abbreviation: P-gp, P-glycoprotein.

2.9 Dosage Modifications for Adverse Reactions

Table 2 summarizes recommendations for dosage modifications of AFINITOR/AFINITOR DISPERZ for the management of adverse reactions.

Table 2: Recommended Dosage Modifications for AFINITOR/AFINITOR DISPERZ for Adverse Reactions

Adverse Reaction	Severity	Dosage Modification
Non-infectious pneumonitis <i>[see Warnings and Precautions (5.1)]</i>	Grade 2	Withhold until improvement to Grade 0 or 1. Resume at 50% of previous dose; change to every other day dosing if the reduced dose is lower than the lowest available strength. Permanently discontinue if toxicity does not resolve or improve to Grade 1 within 4 weeks.
	Grade 3	Withhold until improvement to Grade 0 or 1. Resume at 50% of previous dose; change to every other day dosing if the reduced dose is lower than the lowest available strength. If toxicity recurs at Grade 3, permanently discontinue.
	Grade 4	Permanently discontinue.
Stomatitis <i>[see Warnings and Precautions (5.5)]</i>	Grade 2	Withhold until improvement to Grade 0 or 1. Resume at same dose. If recurs at Grade 2, withhold until improvement to Grade 0 or 1. Resume at 50% of previous dose; change to every other day dosing if the reduced dose is lower than the lowest available strength.
	Grade 3	Withhold until improvement to Grade 0 or 1. Resume at 50% of previous dose; change to every other day dosing if the reduced dose is lower than the lowest available strength.
	Grade 4	Permanently discontinue.
Metabolic events (e.g., hyperglycemia, dyslipidemia) <i>[see Warnings and Precautions (5.9)]</i>	Grade 3	Withhold until improvement to Grade 0, 1, or 2. Resume at 50% of previous dose; change to every other day dosing if the reduced dose is lower than the lowest available strength.
	Grade 4	Permanently discontinue.
Other non-hematologic toxicities	Grade 2	If toxicity becomes intolerable, withhold until improvement to Grade 0 or 1. Resume at same dose. If toxicity recurs at Grade 2, withhold until improvement to Grade 0 or 1. Resume at 50% of previous dose; change to every other day dosing if the reduced dose is lower than the lowest available strength.
	Grade 3	Withhold until improvement to Grade 0 or 1. Consider resuming at 50% of previous dose; change to every other day dosing if the reduced dose is lower than the lowest available strength. If recurs at Grade 3, permanently discontinue.
	Grade 4	Permanently discontinue.
Thrombocytopenia <i>[see Warnings and Precautions (5.10)]</i>	Grade 2	Withhold until improvement to Grade 0 or 1. Resume at same dose.
	Grade 3	Withhold until improvement to Grade 0 or 1. Resume at 50% of previous dose; change to every other day dosing if the reduced dose is lower than the lowest available strength.
	Grade 4	
Neutropenia <i>[see Warnings and Precautions (5.10)]</i>	Grade 3	Withhold until improvement to Grade 0, 1, or 2. Resume at same dose.
	Grade 4	Withhold until improvement to Grade 0, 1, or 2. Resume at 50% of previous dose; change to every other day dosing if the reduced dose is lower than the lowest available strength.

Adverse Reaction	Severity	Dosage Modification
Febrile neutropenia <i>[see Warnings and Precautions (5.10)]</i>	Grade 3	Withhold until improvement to Grade 0, 1, or 2, and no fever. Resume at 50% of previous dose; change to every other day dosing if the reduced dose is lower than the lowest available strength.
	Grade 4	Permanently discontinue.

2.10 Dosage Modifications for Hepatic Impairment

The recommended dosages of AFINITOR/AFINITOR DISPERZ for patients with hepatic impairment are described in Table 3 *[see Use in Specific Populations (8.6)]*:

Table 3: Recommended Dosage Modifications for Patients with Hepatic Impairment

Indication	Dose Modification for AFINITOR/AFINITOR DISPERZ
Breast Cancer, NET, RCC, and TSC-Associated Renal Angiomyolipoma	<ul style="list-style-type: none"> Mild hepatic impairment (Child-Pugh class A) – 7.5 mg orally once daily; decrease the dose to 5 mg orally once daily if a dose of 7.5 mg once daily is not tolerated. Moderate hepatic impairment (Child-Pugh class B) – 5 mg orally once daily; decrease the dose to 2.5 mg orally once daily if a dose of 5 mg once daily is not tolerated. Severe hepatic impairment (Child-Pugh class C) – 2.5 mg orally once daily if the desired benefit outweighs the risk; do not exceed a dose of 2.5 mg once daily.
TSC-Associated SEGA and TSC-Associated Partial-Onset Seizures	<ul style="list-style-type: none"> Severe hepatic impairment (Child-Pugh class C) – 2.5 mg/m² orally once daily. Adjust dose based on everolimus trough concentrations as recommended <i>[see Dosage and Administration (2.8)]</i>.

Abbreviations: NET, Neuroendocrine Tumors; RCC, Renal Cell Carcinoma; SEGA, Subependymal Giant Cell Astrocytoma; TSC, Tuberous Sclerosis Complex.

2.11 Dosage Modifications for P-gp and CYP3A4 Inhibitors

- Avoid the concomitant use of P-gp and strong CYP3A4 inhibitors *[see Drug Interactions (7.1)]*.
- Avoid ingesting grapefruit and grapefruit juice.
- Reduce the dose for patients taking AFINITOR/AFINITOR DISPERZ with a P-gp and moderate CYP3A4 inhibitor as recommended in Table 4 *[see Drug Interactions (7.1), Clinical Pharmacology (12.3)]*.

Table 4: Recommended Dosage Modifications for Concurrent Use of AFINITOR/AFINITOR DISPERZ with a P-gp and Moderate CYP3A4 Inhibitor

Indication	Dose Modification for AFINITOR/AFINITOR DISPERZ
Breast Cancer, NET, RCC, and TSC-Associated Renal Angiomyolipoma	<ul style="list-style-type: none"> Reduce dose to 2.5 mg once daily. May increase dose to 5 mg once daily if tolerated. Resume dose administered prior to inhibitor initiation, once the inhibitor is discontinued for 3 days.
TSC-Associated SEGA and TSC-Associated Partial-Onset Seizures	<ul style="list-style-type: none"> Reduce the daily dose by 50%. Change to every other day dosing if the reduced dose is lower than the lowest available strength. Resume dose administered prior to inhibitor initiation, once the inhibitor is discontinued for 3 days. Assess trough concentrations when initiating and discontinuing the inhibitor <i>[see Dosage and Administration (2.8)]</i>.

2.12 Dosage Modifications for P-gp and CYP3A4 Inducers

- Avoid concomitant use of St. John's Wort (*Hypericum perforatum*).
- Increase the dose for patients taking AFINITOR/AFINITOR DISPERZ with a P-gp and strong CYP3A4 inducer as recommended in Table 5 [see *Drug Interactions (7.1), Clinical Pharmacology (12.3)*].

Table 5: Recommended Dosage Modifications for Concurrent Use of AFINITOR/AFINITOR DISPERZ with P-gp and Strong CYP3A4 Inducers

Indication	Dose Modification for AFINITOR/AFINITOR DISPERZ
Breast Cancer, NET, RCC, and TSC-Associated Renal Angiomyolipoma	<ul style="list-style-type: none">• Avoid coadministration where alternatives exist.• If coadministration cannot be avoided, double the daily dose using increments of 5 mg or less. Multiple increments may be required.• Resume the dose administered prior to inducer initiation, once an inducer is discontinued for 5 days.
TSC-Associated SEGA and TSC-Associated Partial-Onset Seizures	<ul style="list-style-type: none">• Double the daily dose using increments of 5 mg or less. Multiple increments may be required.• Addition of another strong CYP3A4 inducer in a patient already receiving treatment with a strong CYP3A4 inducer may not require additional dosage modification.• Assess trough concentrations when initiating and discontinuing the inducer [see <i>Dosage and Administration (2.8)</i>].• Resume the dose administered before starting any inducer, once all inducers are discontinued for 5 days.

2.13 Administration and Preparation

- Administer AFINITOR/AFINITOR DISPERZ at the same time each day.
- Administer AFINITOR/AFINITOR DISPERZ consistently either with or without food [see *Clinical Pharmacology (12.3)*].
- If a dose of AFINITOR/AFINITOR DISPERZ is missed, it can be administered up to 6 hours after the time it is normally administered. After more than 6 hours, the dose should be skipped for that day. The next day, AFINITOR/AFINITOR DISPERZ should be administered at its usual time. Double doses should not be administered to make up for the dose that was missed.

AFINITOR

- AFINITOR should be swallowed whole with a glass of water. Do not break or crush tablets.

AFINITOR DISPERZ

- Wear gloves to avoid possible contact with everolimus when preparing suspensions of AFINITOR DISPERZ for another person.
- Administer as a suspension only.
- Administer suspension immediately after preparation. Discard suspension if not administered within 60 minutes after preparation.
- Prepare suspension in water only.

Using an Oral Syringe to Prepare Oral Suspension:

- Place the prescribed dose into a 10-mL syringe. Do not exceed a total of 10 mg per syringe. If higher doses are required, prepare an additional syringe. Do not break or crush tablets.
- Draw approximately 5 mL of water and 4 mL of air into the syringe.
- Place the filled syringe into a container (tip up) for 3 minutes, until the tablets are in suspension.
- Gently invert the syringe 5 times immediately prior to administration.

- After administration of the prepared suspension, draw approximately 5 mL of water and 4 mL of air into the same syringe, and swirl the contents to suspend remaining particles. Administer the entire contents of the syringe.

Using a Small Drinking Glass to Prepare Oral Suspension:

- Place the prescribed dose into a small drinking glass (maximum size 100 mL) containing approximately 25 mL of water. Do not exceed a total of 10 mg per glass. If higher doses are required, prepare an additional glass. Do not break or crush tablets.
- Allow 3 minutes for suspension to occur.
- Stir the contents gently with a spoon, immediately prior to drinking.
- After administration of the prepared suspension, add 25 mL of water and stir with the same spoon to re-suspend remaining particles. Administer the entire contents of the glass.

3 DOSAGE FORMS AND STRENGTHS

AFINITOR

Tablets, white to slightly yellow and elongated with a bevelled edge:

- 2.5 mg: engraved with “LCL” on one side and “NVR” on the other.
- 5 mg: engraved with “5” on one side and “NVR” on the other.
- 7.5 mg: engraved with “7P5” on one side and “NVR” on the other.
- 10 mg: engraved with “UHE” on one side and “NVR” on the other.

AFINITOR DISPERZ

Tablets for oral suspension, white to slightly yellowish, round, and flat with a bevelled edge:

- 2 mg: engraved with “D2” on one side and “NVR” on the other.
- 3 mg: engraved with “D3” on one side and “NVR” on the other.
- 5 mg: engraved with “D5” on one side and “NVR” on the other.

4 CONTRAINDICATIONS

AFINITOR/AFINITOR DISPERZ is contraindicated in patients with clinically significant hypersensitivity to everolimus or to other rapamycin derivatives [see *Warnings and Precautions (5.3)*].

5 WARNINGS AND PRECAUTIONS

5.1 Non-infectious Pneumonitis

Non-infectious pneumonitis is a class effect of rapamycin derivatives. Non-infectious pneumonitis was reported in up to 19% of patients treated with AFINITOR/AFINITOR DISPERZ in clinical trials, some cases were reported with pulmonary hypertension (including pulmonary arterial hypertension) as a secondary event. The incidence of Grade 3 and 4 non-infectious pneumonitis was up to 4% and up to 0.2%, respectively [see *Adverse Reactions (6.1)*]. Fatal outcomes have been observed.

Consider a diagnosis of non-infectious pneumonitis in patients presenting with non-specific respiratory signs and symptoms. Consider opportunistic infections such as pneumocystis jiroveci pneumonia (PJP) in the differential diagnosis. Advise patients to report promptly any new or worsening respiratory symptoms.

Continue AFINITOR/AFINITOR DISPERZ without dose alteration in patients who develop radiological changes suggestive of non-infectious pneumonitis and have few or no symptoms. Imaging appears to overestimate the incidence of clinical pneumonitis.

For Grade 2 to 4 non-infectious pneumonitis, withhold or permanently discontinue AFINITOR/AFINITOR DISPERZ based on severity [see *Dosage and Administration (2.9)*]. Corticosteroids may be indicated until clinical symptoms resolve. Administer prophylaxis for PJP when concomitant use of corticosteroids or other immunosuppressive agents are required. The development of pneumonitis has been reported even at a reduced dose.

5.2 Infections

AFINITOR/AFINITOR DISPERZ has immunosuppressive properties and may predispose patients to bacterial, fungal, viral, or protozoal infections, including infections with opportunistic pathogens [see *Adverse Reactions (6.1)*]. Localized and systemic infections, including pneumonia, mycobacterial infections, other bacterial infections, invasive fungal infections (e.g., aspergillosis, candidiasis, or PJP), and viral infections (e.g., reactivation of hepatitis B virus) have occurred. Some of these infections have been severe (e.g., sepsis, septic shock, or resulting in multisystem organ failure) or fatal. The incidence of Grade 3 and 4 infections was up to 10% and up to 3%, respectively. The incidence of serious infections was reported at a higher frequency in patients < 6 years of age [see *Use in Specific Populations (8.4)*].

Complete treatment of preexisting invasive fungal infections prior to starting treatment. Monitor for signs and symptoms of infection. Withhold or permanently discontinue AFINITOR/AFINITOR DISPERZ based on severity of infection [see *Dosage and Administration (2.9)*].

Administer prophylaxis for PJP when concomitant use of corticosteroids or other immunosuppressive agents are required.

5.3 Severe Hypersensitivity Reactions

Hypersensitivity reactions to AFINITOR/AFINITOR DISPERZ have been observed and include anaphylaxis, dyspnea, flushing, chest pain, and angioedema (e.g., swelling of the airways or tongue, with or without respiratory impairment) [see *Contraindications (4)*]. The incidence of Grade 3 hypersensitivity reactions was up to 1%. Permanently discontinue AFINITOR/AFINITOR DISPERZ for the development of clinically significant hypersensitivity.

5.4 Angioedema with Concomitant Use of Angiotensin-Converting Enzyme (ACE) Inhibitors

Patients taking concomitant ACE inhibitors with AFINITOR/AFINITOR DISPERZ may be at increased risk for angioedema (e.g., swelling of the airways or tongue, with or without respiratory impairment). In a pooled analysis of randomized double-blind oncology clinical trials, the incidence of angioedema in patients taking AFINITOR with an ACE inhibitor was 6.8% compared to 1.3% in the control arm with an ACE inhibitor. Permanently discontinue AFINITOR/AFINITOR DISPERZ for angioedema.

5.5 Stomatitis

Stomatitis, including mouth ulcers and oral mucositis, has occurred in patients treated with AFINITOR/AFINITOR DISPERZ at an incidence ranging from 44% to 78% across clinical trials. Grades 3-4 stomatitis was reported in 4% to 9% of patients [see *Adverse Reactions (6.1)*]. Stomatitis most often occurs within the first 8 weeks of treatment. When starting AFINITOR/AFINITOR DISPERZ, initiating dexamethasone alcohol-free oral solution as a swish and spit mouthwash reduces the incidence and severity of stomatitis [see *Adverse Reactions (6.1)*]. If stomatitis does occur, mouthwashes and/or other topical treatments are recommended. Avoid alcohol-, hydrogen peroxide-, iodine-, or thyme-containing products, as they may exacerbate the condition. Do not administer antifungal agents, unless fungal infection has been diagnosed.

5.6 Renal Failure

Cases of renal failure (including acute renal failure), some with a fatal outcome, have occurred in patients taking AFINITOR. Elevations of serum creatinine and proteinuria have been reported in patients taking AFINITOR/AFINITOR DISPERZ [see *Adverse Reactions (6.1)*]. The incidence of Grade 3 and 4 elevations of serum creatinine was up to 2% and up to 1%, respectively. The incidence of Grade 3 and 4 proteinuria was up to 1% and up to 0.5%, respectively. Monitor renal function prior to starting AFINITOR/AFINITOR DISPERZ and annually thereafter. Monitor renal function at least every 6 months in patients who have additional risk factors for renal failure.

5.7 Risk of Impaired Wound Healing

Impaired wound healing can occur in patients who receive drugs that inhibit the VEGF signaling pathway. Therefore, AFINITOR/AFINITOR DISPERZ have the potential to adversely affect wound healing.

Withhold AFINITOR/AFINITOR DISPERZ for at least 1 week prior to elective surgery. Do not administer for at least 2 weeks following major surgery and until adequate wound healing. The safety of resumption of treatment upon resolution of wound healing complications has not been established.

5.8 Geriatric Patients

In the randomized hormone receptor-positive, HER2-negative breast cancer study (BOLERO-2), the incidence of deaths due to any cause within 28 days of the last AFINITOR dose was 6% in patients \geq 65 years of age compared to 2% in patients < 65 years of age. Adverse reactions leading to permanent treatment discontinuation occurred in 33% of patients \geq 65 years of age compared to 17% in patients < 65 years of age. Careful monitoring and appropriate dose adjustments for adverse reactions are recommended [see *Dosage and Administration (2.9)*, *Use in Specific Populations (8.5)*].

5.9 Metabolic Disorders

Hyperglycemia, hypercholesterolemia, and hypertriglyceridemia have been reported in patients taking AFINITOR/AFINITOR DISPERZ at an incidence up to 75%, 86%, and 73%, respectively. The incidence of these Grade 3 and 4 laboratory abnormalities was up to 15% and up to 0.4%, respectively [see *Adverse Reactions (6.1)*]. In non-diabetic patients, monitor fasting serum glucose prior to starting AFINITOR/AFINITOR DISPERZ and annually thereafter. In diabetic patients, monitor fasting serum glucose more frequently as clinically indicated. Monitor lipid profile prior to starting AFINITOR/AFINITOR DISPERZ and annually thereafter. When possible, achieve optimal glucose and lipid control prior to starting AFINITOR/AFINITOR DISPERZ. For Grade 3 to 4 metabolic events, withhold or permanently discontinue AFINITOR/AFINITOR DISPERZ based on severity [see *Dosage and Administration (2.9)*].

5.10 Myelosuppression

Anemia, lymphopenia, neutropenia, and thrombocytopenia have been reported in patients taking AFINITOR/AFINITOR DISPERZ. The incidence of these Grade 3 and 4 laboratory abnormalities was up to 16% and up to 2%, respectively [see *Adverse Reactions (6.1)*]. Monitor complete blood count (CBC) prior to starting AFINITOR/AFINITOR DISPERZ every 6 months for the first year of treatment and annually thereafter. Withhold or permanently discontinue AFINITOR/AFINITOR DISPERZ based on severity [see *Dosage and Administration (2.9)*].

5.11 Risk of Infection or Reduced Immune Response with Vaccination

The safety of immunization with live vaccines during AFINITOR/AFINITOR DISPERZ therapy has not been studied. Due to the potential increased risk of infection, avoid the use of live vaccines and close contact with individuals who have received live vaccines during treatment with AFINITOR/AFINITOR DISPERZ. Due to the potential increased risk of infection or reduced immune response with vaccination, complete the recommended childhood series of vaccinations according to American Council on Immunization Practices (ACIP) guidelines prior to the start of therapy. An accelerated vaccination schedule may be appropriate.

5.12 Embryo-Fetal Toxicity

Based on animal studies and the mechanism of action, AFINITOR/AFINITOR DISPERZ can cause fetal harm when administered to a pregnant woman. In animal studies, everolimus caused embryo-fetal toxicities in rats when administered during the period of organogenesis at maternal exposures that were lower than human exposures at the clinical dose of 10 mg once daily. Advise pregnant women of the potential risk to a fetus. Advise female patients of reproductive potential to avoid becoming pregnant and to use effective contraception during treatment with AFINITOR/AFINITOR DISPERZ and for 8 weeks after the last dose. Advise male patients with female partners of reproductive potential to use effective contraception during treatment with AFINITOR/AFINITOR DISPERZ and for 4 weeks after the last dose [see *Use in Specific Populations (8.1, 8.3)*].

6 ADVERSE REACTIONS

The following serious adverse reactions are described elsewhere in the labeling:

- Non-Infectious Pneumonitis [see *Warnings and Precautions (5.1)*].
- Infections [see *Warnings and Precautions (5.2)*].

- Severe Hypersensitivity Reactions [see Warnings and Precautions (5.3)].
- Angioedema with Concomitant Use of ACE inhibitors [see Warnings and Precautions (5.4)].
- Stomatitis [see Warnings and Precautions (5.5)].
- Renal Failure [see Warnings and Precautions (5.6)].
- Impaired Wound Healing [see Warnings and Precautions (5.7)].
- Metabolic Disorders [see Warnings and Precautions (5.9)].
- Myelosuppression [see Warnings and Precautions (5.10)].

6.1 Clinical Trials Experience

Because clinical trials are conducted under widely varying conditions, the adverse reaction rates observed cannot be directly compared to rates in other trials and may not reflect the rates observed in clinical practice.

Hormone Receptor-Positive, HER2-Negative Breast Cancer

The safety of AFINITOR (10 mg orally once daily) in combination with exemestane (25 mg orally once daily) (n = 485) vs. placebo in combination with exemestane (n = 239) was evaluated in a randomized, controlled trial (BOLERO-2) in patients with advanced or metastatic hormone receptor-positive, HER2-negative breast cancer. The median age of patients was 61 years (28 to 93 years), and 75% were White. The median follow-up was approximately 13 months.

The most common adverse reactions (incidence $\geq 30\%$) were stomatitis, infections, rash, fatigue, diarrhea, and decreased appetite. The most common Grade 3-4 adverse reactions (incidence $\geq 2\%$) were stomatitis, infections, hyperglycemia, fatigue, dyspnea, pneumonitis, and diarrhea. The most common laboratory abnormalities (incidence $\geq 50\%$) were hypercholesterolemia, hyperglycemia, increased aspartate transaminase (AST), anemia, leukopenia, thrombocytopenia, lymphopenia, increased alanine transaminase (ALT), and hypertriglyceridemia. The most common Grade 3-4 laboratory abnormalities (incidence $\geq 3\%$) were lymphopenia, hyperglycemia, anemia, hypokalemia, increased AST, increased ALT, and thrombocytopenia.

Fatal adverse reactions occurred in 2% of patients who received AFINITOR. The rate of adverse reactions resulting in permanent discontinuation was 24% for the AFINITOR arm. Dose adjustments (interruptions or reductions) occurred in 63% of patients in the AFINITOR arm.

Adverse reactions reported with an incidence of $\geq 10\%$ for patients receiving AFINITOR vs. placebo are presented in Table 6. Laboratory abnormalities are presented in Table 7. The median duration of treatment with AFINITOR was 23.9 weeks; 33% were exposed to AFINITOR for a period of ≥ 32 weeks.

Table 6: Adverse Reactions Reported in $\geq 10\%$ of Patients with Hormone Receptor-Positive Breast Cancer in BOLERO-2

	AFINITOR with Exemestane N = 482		Placebo with Exemestane N = 238	
	All Grades %	Grade 3-4 %	All Grades %	Grade 3-4 %
Gastrointestinal				
Stomatitis ^a	67	8 ^d	11	0.8
Diarrhea	33	2	18	0.8
Nausea	29	0.4	28	1
Vomiting	17	1	12	0.8
Constipation	14	0.4 ^d	13	0.4
Dry mouth	11	0	7	0
General				
Fatigue	36	4	27	1 ^d
Edema peripheral	19	1 ^d	6	0.4 ^d
Pyrexia	15	0.2 ^d	7	0.4 ^d

	AFINITOR with Exemestane N = 482		Placebo with Exemestane N = 238	
	All Grades	Grade 3-4	All Grades	Grade 3-4
	%	%	%	%
Asthenia	13	2	4	0
Infections				
Infections ^b	50	6	25	2 ^d
Investigations				
Weight loss	25	1 ^d	6	0
Metabolism and nutrition				
Decreased appetite	30	1 ^d	12	0.4 ^d
Hyperglycemia	14	5	2	0.4 ^d
Musculoskeletal and connective tissue				
Arthralgia	20	0.8 ^d	17	0
Back pain	14	0.2 ^d	10	0.8 ^d
Pain in extremity	9	0.4 ^d	11	2 ^d
Nervous system				
Dysgeusia	22	0.2 ^d	6	0
Headache	21	0.4 ^d	14	0
Psychiatric				
Insomnia	13	0.2 ^d	8	0
Respiratory, thoracic and mediastinal				
Cough	24	0.6 ^d	12	0
Dyspnea	21	4	11	1
Epistaxis	17	0	1	0
Pneumonitis ^c	19	4	0.4	0
Skin and subcutaneous tissue				
Rash	39	1 ^d	6	0
Pruritus	13	0.2 ^d	5	0
Alopecia	10	0	5	0
Vascular				
Hot flush	6	0	14	0

Grading according to NCI CTCAE Version 3.0.

^aIncludes stomatitis, mouth ulceration, aphthous stomatitis, glossodynia, gingival pain, glossitis, and lip ulceration.

^bIncludes all reported infections including, but not limited to, urinary tract infections, respiratory tract (upper and lower) infections, skin infections, and gastrointestinal tract infections.

^cIncludes pneumonitis, interstitial lung disease, lung infiltration, and pulmonary fibrosis.

^dNo Grade 4 adverse reactions were reported.

Table 7: Selected Laboratory Abnormalities Reported in ≥ 10% of Patients with Hormone Receptor-Positive Breast Cancer in BOLERO-2

Laboratory Parameter	AFINITOR with Exemestane N = 482		Placebo with Exemestane N = 238	
	All Grades	Grade 3-4	All Grades	Grade 3-4
	%	%	%	%
Hematology^a				
Anemia	68	6	40	1

Laboratory Parameter	AFINITOR with Exemestane N = 482		Placebo with Exemestane N = 238	
	All Grades	Grade 3-4	All Grades	Grade 3-4
	%	%	%	%
Leukopenia	58	2 ^b	28	6
Thrombocytopenia	54	3	5	0.4
Lymphopenia	54	12	37	6
Neutropenia	31	2 ^b	11	2
Chemistry				
Hypercholesterolemia	70	1	38	2
Hyperglycemia	69	9	44	1
Increased AST	69	4	45	3
Increased ALT	51	4	29	5 ^b
Hypertriglyceridemia	50	0.8 ^b	26	0
Hypoalbuminemia	33	0.8 ^b	16	0.8 ^b
Hypokalemia	29	4	7	1 ^b
Increased creatinine	24	2	13	0

Grading according to NCI CTCAE Version 3.0.

^aReflects corresponding adverse drug reaction reports of anemia, leukopenia, lymphopenia, neutropenia, and thrombocytopenia (collectively as pancytopenia), which occurred at lower frequency.

^bNo Grade 4 laboratory abnormalities were reported.

Topical Prophylaxis for Stomatitis

In a single arm study (SWISH; N = 92) in postmenopausal women with hormone receptor-positive, HER2-negative breast cancer beginning AFINITOR (10 mg orally once daily) in combination with exemestane (25 mg orally once daily), patients started dexamethasone 0.5 mg/5mL alcohol-free mouthwash (10 mL swished for 2 minutes and spat, 4 times daily for 8 weeks) concurrently with AFINITOR and exemestane. No food or drink was to be consumed for at least 1 hour after swishing and spitting the dexamethasone mouthwash. The primary objective of this study was to assess the incidence of Grade 2 to 4 stomatitis within 8 weeks. The incidence of Grade 2 to 4 stomatitis within 8 weeks was 2%, which was lower than the 33% reported in the BOLERO-2 trial. The incidence of Grade 1 stomatitis was 19%. No cases of Grade 3 or 4 stomatitis were reported. Oral candidiasis was reported in 2% of patients in this study compared to 0.2% in the BOLERO-2 trial.

Coadministration of AFINITOR/AFINITOR DISPERZ and dexamethasone alcohol-free oral solution has not been studied in pediatric patients.

Pancreatic Neuroendocrine Tumors (PNET)

In a randomized, controlled trial (RADIANT-3) of AFINITOR (n = 204) vs. placebo (n = 203) in patients with advanced PNET the median age of patients was 58 years (20 to 87 years), 79% were White, and 55% were male. Patients on the placebo arm could cross over to open-label AFINITOR upon disease progression.

The most common adverse reactions (incidence \geq 30%) were stomatitis, rash, diarrhea, fatigue, edema, abdominal pain, nausea, fever, and headache. The most common Grade 3-4 adverse reactions (incidence \geq 5%) were stomatitis and diarrhea. The most common laboratory abnormalities (incidence \geq 50%) were anemia, hyperglycemia, increased alkaline phosphatase, hypercholesterolemia, decreased bicarbonate, and increased AST. The most common Grade 3-4 laboratory abnormalities (incidence \geq 3%) were hyperglycemia, lymphopenia, anemia, hypophosphatemia, increased alkaline phosphatase, neutropenia, increased AST, hypokalemia, and thrombocytopenia.

Deaths during double-blind treatment where an adverse reaction was the primary cause occurred in seven patients on AFINITOR. Causes of death on the AFINITOR arm included one case of each of the following: acute renal failure, acute

respiratory distress, cardiac arrest, death (cause unknown), hepatic failure, pneumonia, and sepsis. After cross-over to open-label AFINITOR, there were three additional deaths, one due to hypoglycemia and cardiac arrest in a patient with insulinoma, one due to myocardial infarction with congestive heart failure, and the other due to sudden death. The rate of adverse reactions resulting in permanent discontinuation was 20% for the AFINITOR group. Dose delay or reduction was necessary in 61% of AFINITOR patients. Grade 3-4 renal failure occurred in six patients in the AFINITOR arm. Thrombotic events included five patients with pulmonary embolus in the AFINITOR arm as well as three patients with thrombosis in the AFINITOR arm.

Table 8 compares the incidence of adverse reactions reported with an incidence of $\geq 10\%$ for patients receiving AFINITOR vs. placebo. Laboratory abnormalities are summarized in Table 9. The median duration of treatment in patients who received AFINITOR was 37 weeks.

In female patients aged 18 to 55 years, irregular menstruation occurred in 5 of 46 (11%) AFINITOR-treated females.

Table 8: Adverse Reactions Reported in $\geq 10\%$ of Patients with PNET in RADIANT-3

	AFINITOR N = 204		Placebo N = 203	
	All Grades %	Grade 3-4 %	All Grades %	Grade 3-4 %
Gastrointestinal				
Stomatitis ^a	70	7 ^d	20	0
Diarrhea ^b	50	6	25	3 ^d
Abdominal pain	36	4 ^d	32	7
Nausea	32	2 ^d	33	2 ^d
Vomiting	29	1 ^d	21	2 ^d
Constipation	14	0	13	0.5 ^d
Dry mouth	11	0	4	0
General				
Fatigue/malaise	45	4	27	3
Edema (general and peripheral)	39	2	12	1 ^d
Fever	31	1	13	0.5 ^d
Asthenia	19	3 ^d	20	3 ^d
Infections				
Nasopharyngitis/rhinitis/URI	25	0	13	0
Urinary tract infection	16	0	6	0.5 ^d
Investigations				
Weight loss	28	0.5 ^d	11	0
Metabolism and nutrition				
Decreased appetite	30	1 ^d	18	1 ^d
Diabetes mellitus	10	2 ^d	0.5	0
Musculoskeletal and connective tissue				
Arthralgia	15	1	7	0.5 ^d
Back pain	15	1 ^d	11	1 ^d
Pain in extremity	14	0.5 ^d	6	1 ^d
Muscle spasms	10	0	4	0
Nervous system				
Headache/migraine	30	0.5 ^d	15	1 ^d
Dysgeusia	19	0	5	0

	AFINITOR N = 204		Placebo N = 203	
	All Grades	Grade 3-4	All Grades	Grade 3-4
	%	%	%	%
Dizziness	12	0.5 ^d	7	0
Psychiatric				
Insomnia	14	0	8	0
Respiratory, thoracic and mediastinal				
Cough/productive cough	25	0.5 ^d	13	0
Epistaxis	22	0	1	0
Dyspnea/dyspnea exertional	20	3	7	0.5 ^d
Pneumonitis ^c	17	4	0	0
Oropharyngeal pain	11	0	6	0
Skin and subcutaneous				
Rash	59	0.5	19	0
Nail disorders	22	0.5	2	0
Pruritus/pruritus generalized	21	0	13	0
Dry skin/xeroderma	13	0	6	0
Vascular				
Hypertension	13	1	6	1 ^d

Grading according to NCI CTCAE Version 3.0.

^aIncludes stomatitis, aphthous stomatitis, gingival pain/swelling/ulceration, glossitis, glossodynia, lip ulceration, mouth ulceration, tongue ulceration, and mucosal inflammation.

^bIncludes diarrhea, enteritis, enterocolitis, colitis, defecation urgency, and steatorrhea.

^cIncludes pneumonitis, interstitial lung disease, pulmonary fibrosis, and restrictive pulmonary disease.

^dNo Grade 4 adverse reactions were reported.

Table 9: Selected Laboratory Abnormalities Reported in ≥ 10% of Patients with PNET in RADIANT-3

Laboratory parameter	AFINITOR N = 204		Placebo N = 203	
	All Grades	Grade 3-4	All Grades	Grade 3-4
	%	%	%	%
Hematology				
Anemia	86	15	63	1
Lymphopenia	45	16	22	4
Thrombocytopenia	45	3	11	0
Leukopenia	43	2	13	0
Neutropenia	30	4	17	2
Chemistry				
Hyperglycemia (fasting)	75	17	53	6
Increased alkaline phosphatase	74	8	66	8
Hypercholesterolemia	66	0.5	22	0
Bicarbonate decreased	56	0	40	0
Increased AST	56	4	41	4
Increased ALT	48	2	35	2
Hypophosphatemia	40	10	14	3

Laboratory parameter	AFINITOR N = 204		Placebo N = 203	
	All Grades	Grade 3-4	All Grades	Grade 3-4
	%	%	%	%
Hypertriglyceridemia	39	0	10	0
Hypocalcemia	37	0.5	12	0
Hypokalemia	23	4	5	0
Increased creatinine	19	2	14	0
Hyponatremia	16	1	16	1
Hypoalbuminemia	13	1	8	0
Hyperbilirubinemia	10	1	14	2
Hyperkalemia	7	0	10	0.5

Grading according to NCI CTCAE Version 3.0.

Neuroendocrine Tumors (NET) of Gastrointestinal (GI) or Lung Origin

In a randomized, controlled trial (RADIANT-4) of AFINITOR (n = 202 treated) vs. placebo (n = 98 treated) in patients with advanced non-functional NET of GI or lung origin, the median age of patients was 63 years (22-86 years), 76% were White, and 53% were female. The median duration of exposure to AFINITOR was 9.3 months; 64% of patients were treated for ≥ 6 months and 39% were treated for ≥ 12 months. AFINITOR was discontinued for adverse reactions in 29% of patients, dose reduction or delay was required in 70% of AFINITOR-treated patients.

Serious adverse reactions occurred in 42% of AFINITOR-treated patients and included 3 fatal events (cardiac failure, respiratory failure, and septic shock). Adverse reactions occurring at an incidence of $\geq 10\%$ and at $\geq 5\%$ absolute incidence over placebo (all Grades) or $\geq 2\%$ higher incidence over placebo (Grade 3 and 4) are presented in Table 10. Laboratory abnormalities are presented in Table 11.

Table 10: Adverse Reactions in $\geq 10\%$ of AFINITOR-Treated Patients with Non-Functional NET of GI or Lung Origin in RADIANT-4

	AFINITOR N = 202		Placebo N = 98	
	All Grades	Grade 3-4	All Grades	Grade 3-4
	%	%	%	%
Gastrointestinal				
Stomatitis ^a	63	9 ^d	22	0
Diarrhea	41	9	31	2 ^d
Nausea	26	3	17	1 ^d
Vomiting	15	4 ^d	12	2 ^d
General				
Peripheral edema	39	3 ^d	6	1 ^d
Fatigue	37	5	36	1 ^d
Asthenia	23	3	8	0
Pyrexia	23	2	8	0
Infections				
Infections ^b	58	11	29	2
Investigations				
Weight loss	22	2 ^d	11	1 ^d

	AFINITOR N = 202		Placebo N = 98	
	All Grades	Grade 3-4	All Grades	Grade 3-4
	%	%	%	%
Metabolism and nutrition				
Decreased appetite	22	1 ^d	17	1 ^d
Nervous system				
Dysgeusia	18	1 ^d	4	0
Respiratory, thoracic and mediastinal				
Cough	27	0	20	0
Dyspnea	20	3 ^d	11	2
Pneumonitis ^c	16	2 ^d	2	0
Epistaxis	13	1 ^d	3	0
Skin and subcutaneous				
Rash	30	1 ^d	9	0
Pruritus	17	1 ^d	9	0

Grading according to NCI CTCAE Version 4.03.

^aIncludes stomatitis, mouth ulceration, aphthous stomatitis, gingival pain, glossitis, tongue ulceration, and mucosal inflammation.

^bUrinary tract infection, nasopharyngitis, upper respiratory tract infection, lower respiratory tract infection (pneumonia, bronchitis), abscess, pyelonephritis, septic shock and viral myocarditis.

^cIncludes pneumonitis and interstitial lung disease.

^dNo Grade 4 adverse reactions were reported.

Table 11: Selected Laboratory Abnormalities in $\geq 10\%$ of AFINITOR-Treated Patients with Non-Functional NET of GI or Lung Origin in RADIANT-4

	AFINITOR N = 202		Placebo N = 98	
	All Grades	Grade 3-4	All Grades	Grade 3-4
	%	%	%	%
Hematology				
Anemia	81	5 ^a	41	2 ^a
Lymphopenia	66	16	32	2 ^a
Leukopenia	49	2 ^a	17	0
Thrombocytopenia	33	2	11	0
Neutropenia	32	2 ^a	15	3 ^a
Chemistry				
Hypercholesterolemia	71	0	37	0
Increased AST	57	2	34	2 ^a
Hyperglycemia (fasting)	55	6 ^a	36	1 ^a
Increased ALT	46	5	39	1 ^a
Hypophosphatemia	43	4 ^a	15	2 ^a
Hypertriglyceridemia	30	3	8	1 ^a
Hypokalemia	27	6	12	3 ^a
Hypoalbuminemia	18	0	8	0

Grading according to NCI CTCAE Version 4.03.

^aNo Grade 4 laboratory abnormalities were reported.

Renal Cell Carcinoma (RCC)

The data described below reflect exposure to AFINITOR (n = 274) and placebo (n = 137) in a randomized, controlled trial (RECORD-1) in patients with metastatic RCC who received prior treatment with sunitinib and/or sorafenib. The median age of patients was 61 years (27 to 85 years), 88% were White, and 78% were male. The median duration of blinded study treatment was 141 days (19 to 451 days) for patients receiving AFINITOR.

The most common adverse reactions (incidence $\geq 30\%$) were stomatitis, infections, asthenia, fatigue, cough, and diarrhea. The most common Grade 3-4 adverse reactions (incidence $\geq 3\%$) were infections, dyspnea, fatigue, stomatitis, dehydration, pneumonitis, abdominal pain, and asthenia. The most common laboratory abnormalities (incidence $\geq 50\%$) were anemia, hypercholesterolemia, hypertriglyceridemia, hyperglycemia, lymphopenia, and increased creatinine. The most common Grade 3-4 laboratory abnormalities (incidence $\geq 3\%$) were lymphopenia, hyperglycemia, anemia, hypophosphatemia, and hypercholesterolemia.

Deaths due to acute respiratory failure (0.7%), infection (0.7%), and acute renal failure (0.4%) were observed on the AFINITOR arm. The rate of adverse reactions resulting in permanent discontinuation was 14% for the AFINITOR group. The most common adverse reactions leading to treatment discontinuation were pneumonitis and dyspnea. Infections, stomatitis, and pneumonitis were the most common reasons for treatment delay or dose reduction. The most common medical interventions required during AFINITOR treatment were for infections, anemia, and stomatitis.

Adverse reactions reported with an incidence of $\geq 10\%$ for patients receiving AFINITOR vs. placebo are presented in Table 12. Laboratory abnormalities are presented in Table 13.

Table 12: Adverse Reactions Reported in $\geq 10\%$ of Patients with RCC and at a Higher Rate in the AFINITOR Arm than in the Placebo Arm in RECORD-1

	AFINITOR N = 274		Placebo N = 137	
	All Grades %	Grade 3-4 %	All Grades %	Grade 3-4 %
Gastrointestinal				
Stomatitis ^a	44	4	8	0
Diarrhea	30	2 ^d	7	0
Nausea	26	2 ^d	19	0
Vomiting	20	2 ^d	12	0
Infections^b	37	10	18	2
General				
Asthenia	33	4	23	4
Fatigue	31	6 ^d	27	4
Edema peripheral	25	< 1 ^d	8	< 1 ^d
Pyrexia	20	< 1 ^d	9	0
Mucosal inflammation	19	2 ^d	1	0
Respiratory, thoracic and mediastinal				
Cough	30	< 1 ^d	16	0
Dyspnea	24	8	15	3 ^d
Epistaxis	18	0	0	0
Pneumonitis ^c	14	4 ^d	0	0
Skin and subcutaneous tissue				
Rash	29	1 ^d	7	0
Pruritus	14	< 1 ^d	7	0

	AFINITOR N = 274		Placebo N = 137	
	All Grades %	Grade 3-4 %	All Grades %	Grade 3-4 %
Dry skin	13	< 1 ^d	5	0
Metabolism and nutrition				
Anorexia	25	2 ^d	14	< 1 ^d
Nervous system				
Headache	19	1	9	< 1 ^d
Dysgeusia	10	0	2	0
Musculoskeletal and connective tissue				
Pain in extremity	10	1 ^d	7	0

Grading according to NCI CTCAE Version 3.0.

^aStomatitis (including aphthous stomatitis), and mouth and tongue ulceration.

^bIncludes all reported infections including, but not limited to, respiratory tract (upper and lower) infections, urinary tract infections, and skin infections.

^cIncludes pneumonitis, interstitial lung disease, lung infiltration, pulmonary alveolar hemorrhage, pulmonary toxicity, and alveolitis.

^dNo Grade 4 adverse reactions were reported.

Other notable adverse reactions occurring more frequently with AFINITOR than with placebo, but with an incidence of < 10% include:

Gastrointestinal: Abdominal pain (9%), dry mouth (8%), hemorrhoids (5%), dysphagia (4%)

General: Weight loss (9%), chest pain (5%), chills (4%), impaired wound healing (< 1%)

Respiratory, thoracic and mediastinal: Pleural effusion (7%), pharyngolaryngeal pain (4%), rhinorrhea (3%)

Skin and subcutaneous tissue: Hand-foot syndrome (reported as palmar-plantar erythrodysesthesia syndrome) (5%), nail disorder (5%), erythema (4%), onychoclasia (4%), skin lesion (4%), acneiform dermatitis (3%), angioedema (< 1%)

Metabolism and nutrition: Exacerbation of pre-existing diabetes mellitus (2%), new onset of diabetes mellitus (< 1%)

Psychiatric: Insomnia (9%)

Nervous system: Dizziness (7%), paresthesia (5%)

Ocular: Eyelid edema (4%), conjunctivitis (2%)

Vascular: Hypertension (4%), deep vein thrombosis (< 1%)

Renal and urinary: Renal failure (3%)

Cardiac: Tachycardia (3%), congestive cardiac failure (1%)

Musculoskeletal and connective tissue: Jaw pain (3%)

Hematologic: Hemorrhage (3%)

Table 13: Selected Laboratory Abnormalities Reported in Patients with RCC at a Higher Rate in the AFINITOR Arm Than the Placebo Arm in RECORD-1

Laboratory parameter	AFINITOR N = 274		Placebo N = 137	
	All Grades %	Grade 3-4 %	All Grades %	Grade 3-4 %
Hematology^a				
Anemia	92	13	79	6
Lymphopenia	51	18	28	5 ^b
Thrombocytopenia	23	1 ^b	2	< 1
Neutropenia	14	< 1	4	0
Chemistry				
Hypercholesterolemia	77	4 ^b	35	0
Hypertriglyceridemia	73	< 1 ^b	34	0
Hyperglycemia	57	16	25	2 ^b
Increased creatinine increased	50	2 ^b	34	0
Hypophosphatemia	37	6 ^b	8	0
Increased AST	25	1	7	0
Increased ALT	21	1 ^b	4	0
Hyperbilirubinemia	3	1	2	0

Grading according to NCI CTCAE Version 3.0.

^aReflects corresponding adverse drug reaction reports of anemia, leukopenia, lymphopenia, neutropenia, and thrombocytopenia (collectively pancytopenia), which occurred at lower frequency.

^bNo Grade 4 laboratory abnormalities were reported.

Tuberous Sclerosis Complex (TSC)-Associated Renal Angiomyolipoma

The data described below are based on a randomized (2:1), double-blind, placebo-controlled trial (EXIST-2) of AFINITOR in 118 patients with renal angiomyolipoma as a feature of TSC (n = 113) or sporadic lymphangioliomyomatosis (n = 5). The median age of patients was 31 years (18 to 61 years), 89% were White, and 34% were male. The median duration of blinded study treatment was 48 weeks (2 to 115 weeks) for patients receiving AFINITOR.

The most common adverse reaction reported for AFINITOR (incidence $\geq 30\%$) was stomatitis. The most common Grade 3-4 adverse reactions (incidence $\geq 2\%$) were stomatitis and amenorrhea. The most common laboratory abnormalities (incidence $\geq 50\%$) were hypercholesterolemia, hypertriglyceridemia, and anemia. The most common Grade 3-4 laboratory abnormality (incidence $\geq 3\%$) was hypophosphatemia.

The rate of adverse reactions resulting in permanent discontinuation was 3.8% in the AFINITOR-treated patients. Adverse reactions leading to permanent discontinuation in the AFINITOR arm were hypersensitivity/angioedema/bronchospasm, convulsion, and hypophosphatemia. Dose adjustments (interruptions or reductions) due to adverse reactions occurred in 52% of AFINITOR-treated patients. The most common adverse reaction leading to AFINITOR dose adjustment was stomatitis.

Adverse reactions reported with an incidence of $\geq 10\%$ for patients receiving AFINITOR and occurring more frequently with AFINITOR than with placebo are presented in Table 14. Laboratory abnormalities are presented in Table 15.

Table 14: Adverse Reactions Reported in ≥ 10% of AFINITOR-Treated Patients with TSC-Associated Renal Angiomyolipoma in EXIST-2

	AFINITOR N = 79		Placebo N = 39	
	All Grades %	Grade 3-4 %	All Grades %	Grade 3-4 %
Gastrointestinal				
Stomatitis ^a	78	6 ^b	23	0
Vomiting	15	0	5	0
Diarrhea	14	0	5	0
General				
Peripheral edema	13	0	8	0
Infections				
Upper respiratory tract infection	11	0	5	0
Musculoskeletal and connective tissue				
Arthralgia	13	0	5	0
Respiratory, thoracic and mediastinal				
Cough	20	0	13	0
Skin and subcutaneous tissue				
Acne	22	0	5	0

Grading according to NCI CTCAE Version 3.0.

^aIncludes stomatitis, aphthous stomatitis, mouth ulceration, gingival pain, glossitis, and glossodynia.

^bNo Grade 4 adverse reactions were reported.

Amenorrhea occurred in 15% of AFINITOR-treated females (8 of 52). Other adverse reactions involving the female reproductive system were menorrhagia (10%), menstrual irregularities (10%), and vaginal hemorrhage (8%).

The following additional adverse reactions occurred in less than 10% of AFINITOR-treated patients: epistaxis (9%), decreased appetite (6%), otitis media (6%), depression (5%), abnormal taste (5%), increased blood luteinizing hormone (LH) levels (4%), increased blood follicle stimulating hormone (FSH) levels (3%), hypersensitivity (3%), ovarian cyst (3%), pneumonitis (1%), and angioedema (1%).

Table 15: Selected Laboratory Abnormalities Reported in AFINITOR-Treated Patients with TSC-Associated Renal Angiomyolipoma in EXIST-2

	AFINITOR N = 79		Placebo N = 39	
	All Grades %	Grade 3-4 %	All Grades %	Grade 3-4 %
Hematology				
Anemia	61	0	49	0
Leukopenia	37	0	21	0
Neutropenia	25	1	26	0
Lymphopenia	20	1 ^a	8	0
Thrombocytopenia	19	0	3	0
Chemistry				
Hypercholesterolemia	85	1 ^a	46	0
Hypertriglyceridemia	52	0	10	0
Hypophosphatemia	49	5 ^a	15	0

	AFINITOR N = 79		Placebo N = 39	
	All Grades	Grade 3-4	All Grades	Grade 3-4
	%	%	%	%
Increased alkaline phosphatase	32	1 ^a	10	0
Increased AST	23	1 ^a	8	0
Increased ALT	20	1 ^a	15	0
Hyperglycemia (fasting)	14	0	8	0

Grading according to NCI CTCAE Version 3.0.

^aNo Grade 4 laboratory abnormalities were reported.

Updated safety information from 112 patients treated with AFINITOR for a median duration of 3.9 years identified the following additional adverse reactions and selected laboratory abnormalities: increased partial thromboplastin time (63%), increased prothrombin time (40%), decreased fibrinogen (38%), urinary tract infection (31%), proteinuria (18%), abdominal pain (16%), pruritus (12%), gastroenteritis (12%), myalgia (11%), and pneumonia (10%).

TSC-Associated Subependymal Giant Cell Astrocytoma (SEGA)

The data described below are based on a randomized (2:1), double-blind, placebo-controlled trial (EXIST-1) of AFINITOR in 117 patients with SEGA and TSC. The median age of patients was 9.5 years (0.8 to 26 years), 93% were White, and 57% were male. The median duration of blinded study treatment was 52 weeks (24 to 89 weeks) for patients receiving AFINITOR.

The most common adverse reactions reported for AFINITOR (incidence \geq 30%) were stomatitis and respiratory tract infection. The most common Grade 3-4 adverse reactions (incidence \geq 2%) were stomatitis, pyrexia, pneumonia, gastroenteritis, aggression, agitation, and amenorrhea. The most common laboratory abnormalities (incidence \geq 50%) were hypercholesterolemia and elevated partial thromboplastin time. The most common Grade 3-4 laboratory abnormality (incidence \geq 3%) was neutropenia.

There were no adverse reactions resulting in permanent discontinuation. Dose adjustments (interruptions or reductions) due to adverse reactions occurred in 55% of AFINITOR-treated patients. The most common adverse reaction leading to AFINITOR dose adjustment was stomatitis.

Adverse reactions reported with an incidence of \geq 10% for patients receiving AFINITOR and occurring more frequently with AFINITOR than with placebo are reported in Table 16. Laboratory abnormalities are presented in Table 17.

Table 16: Adverse Reactions Reported in \geq 10% of AFINITOR-Treated Patients with TSC-Associated SEGA in EXIST-1

	AFINITOR N = 78		Placebo N = 39	
	All Grades	Grade 3-4	All Grades	Grade 3-4
	%	%	%	%
Gastrointestinal				
Stomatitis ^a	62	9 ^f	26	3 ^f
Vomiting	22	1 ^f	13	0
Diarrhea	17	0	5	0
Constipation	10	0	3	0
Infections				
Respiratory tract infection ^b	31	3	23	0
Gastroenteritis ^c	10	5	3	0
Pharyngitis streptococcal	10	0	3	0
General				

	AFINITOR N = 78		Placebo N = 39	
	All Grades	Grade 3-4	All Grades	Grade 3-4
	%	%	%	%
Pyrexia	23	6 ^f	18	3 ^f
Fatigue	14	0	3	0
Psychiatric				
Anxiety, aggression or other behavioral disturbance ^d	21	5 ^f	3	0
Skin and subcutaneous tissue				
Rash ^e	21	0	8	0
Acne	10	0	5	0

Grading according to NCI CTCAE Version 3.0.

^aIncludes mouth ulceration, stomatitis, and lip ulceration.

^bIncludes respiratory tract infection, upper respiratory tract infection, and respiratory tract infection viral.

^cIncludes gastroenteritis, gastroenteritis viral, and gastrointestinal infection.

^dIncludes agitation, anxiety, panic attack, aggression, abnormal behavior, and obsessive compulsive disorder.

^eIncludes rash, rash generalized, rash macular, rash maculo-papular, rash papular, dermatitis allergic, and urticaria.

^fNo Grade 4 adverse reactions were reported.

Amenorrhea occurred in 17% of AFINITOR-treated females aged 10 to 55 years (3 of 18). For this same group of AFINITOR-treated females, the following menstrual abnormalities were reported: dysmenorrhea (6%), menorrhagia (6%), metrorrhagia (6%), and unspecified menstrual irregularity (6%).

The following additional adverse reactions occurred in less than 10% of AFINITOR-treated patients: nausea (8%), pain in extremity (8%), insomnia (6%), pneumonia (6%), epistaxis (5%), hypersensitivity (3%), increased blood luteinizing hormone (LH) levels (1%), and pneumonitis (1%).

Table 17: Selected Laboratory Abnormalities Reported in AFINITOR-Treated Patients with TSC-Associated SEGA in EXIST-1

	AFINITOR N = 78		Placebo N = 39	
	All Grades	Grade 3-4	All Grades	Grade 3-4
	%	%	%	%
Hematology				
Elevated partial thromboplastin time	72	3 ^a	44	5 ^a
Neutropenia	46	9 ^a	41	3 ^a
Anemia	41	0	21	0
Chemistry				
Hypercholesterolemia	81	0	39	0
Elevated AST	33	0	0	0
Hypertriglyceridemia	27	0	15	0
Elevated ALT	18	0	3	0
Hypophosphatemia	9	1 ^a	3	0

Grading according to NCI CTCAE Version 3.0.

^aNo Grade 4 laboratory abnormalities were reported.

Updated safety information from 111 patients treated with AFINITOR for a median duration of 47 months identified the following additional notable adverse reactions and selected laboratory abnormalities: decreased appetite (14%),

hyperglycemia (13%), hypertension (11%), urinary tract infection (9%), decreased fibrinogen (8%), cellulitis (6%), abdominal pain (5%), decreased weight (5%), elevated creatinine (5%), and azoospermia (1%).

TSC-Associated Partial-Onset Seizures

The data described below are based on the 18-week Core phase of a randomized, double-blind, multicenter, three-arm trial (EXIST-3) comparing two everolimus trough levels (3-7 ng/mL and 9-15 ng/mL) to placebo as adjunctive antiepileptic therapy in patients with TSC-associated partial-onset seizures. A total of 366 patients were randomized to AFINITOR DISPERZ low trough (LT) (n = 117), AFINITOR DISPERZ high trough (HT) (n = 130), or placebo (n = 119). The median age of patients was 10 years (2.2 to 56 years; 28% were < 6 years, 31% were 6 to < 12 years, 22% were 12 to < 18 years, and 18% were ≥ 18 years), 65% were White, and 52% were male. Patients received between one and three concomitant antiepileptic drugs.

The most common adverse reaction reported for AFINITOR DISPERZ in both arms (incidence ≥ 30%) was stomatitis. The most common Grade 3-4 adverse reactions (incidence ≥ 2%) were stomatitis, pneumonia, and irregular menstruation. The most common laboratory abnormality (incidence ≥ 50%) was hypercholesterolemia. The most common Grade 3-4 laboratory abnormality (incidence ≥ 2%) was neutropenia.

Adverse reactions leading to study drug discontinuation occurred in 5% and 3% of patients in the LT and HT arms, respectively. The most common adverse reaction (incidence ≥ 1%) leading to discontinuation was stomatitis. Dose adjustments (interruptions or reductions) due to adverse reactions occurred in 24% and 35% of patients in the LT and HT arms, respectively. The most common adverse reactions (incidence ≥ 3%) leading to dose adjustments in the AFINITOR DISPERZ arms were stomatitis, pneumonia, and pyrexia.

Adverse reactions reported with an incidence of ≥ 10% for patients receiving AFINITOR DISPERZ are presented in Table 18. Laboratory abnormalities are presented in Table 19.

Table 18: Adverse Reactions Reported in ≥ 10% of AFINITOR DISPERZ-Treated Patients with TSC-Associated Partial-Onset Seizures in EXIST-3

	AFINITOR DISPERZ				Placebo	
	Target of 3-7 ng/mL N = 117		Target of 9-15 ng/mL N = 130		N = 119	
	All Grades %	Grade 3-4 %	All Grades %	Grade 3-4 %	All Grades %	Grade 3-4 %
Gastrointestinal						
Stomatitis ^a	55	3 ^b	64	4 ^b	9	0
Diarrhea	17	0	22	0	5	0
Vomiting	12	0	10	2 ^b	9	0
Infections						
Nasopharyngitis	14	0	16	0	16	0
Upper respiratory tract infection	13	0	15	0	13	0.8 ^b
General						
Pyrexia	20	0	14	0.8 ^b	5	0
Respiratory, thoracic and mediastinal						
Cough	11	0	10	0	3	0
Skin and subcutaneous tissue						
Rash	6	0	10	0	3	0

AFINITOR DISPERZ				Placebo	
Target of 3-7 ng/mL N = 117		Target of 9-15 ng/mL N = 130		N = 119	
All Grades	Grade 3-4	All Grades	Grade 3-4	All Grades	Grade 3-4
%	%	%	%	%	%

^aIncludes stomatitis, mouth ulceration, aphthous ulcer, lip ulceration, tongue ulceration, mucosal inflammation, gingival pain.

^bNo Grade 4 adverse reactions were reported.

The following additional adverse reactions occurred in < 10% of AFINITOR DISPERZ treated patients (% AFINITOR DISPERZ LT, % AFINITOR DISPERZ HT): decreased appetite (9%, 7%), pneumonia (2%, 4%), aggression (2%, 0.8%), proteinuria (0%, 2%), menorrhagia (0.9%, 0.8%), and pneumonitis (0%, 0.8%).

Table 19: Selected Laboratory Abnormalities Reported in ≥ 10% AFINITOR DISPERZ-Treated Patients with TSC-Associated Partial-Onset Seizures

	AFINITOR DISPERZ				Placebo	
	Target of 3-7 ng/mL N = 117		Target of 9-15 ng/mL N = 130		N = 119	
	All Grades	Grade 3-4	All Grades	Grade 3-4	All Grades	Grade 3-4
	%	%	%	%	%	%
Hematology						
Neutropenia	25	4 ^a	37	6	23	7 ^a
Anemia	27	0.9 ^a	30	0	21	0.8 ^a
Thrombocytopenia	12	0	15	0	6	0
Chemistry						
Hypercholesterolemia	86	0	85	0.8 ^a	58	0
Hypertriglyceridemia	43	2 ^a	39	2	22	0
Increased ALT	17	0	22	0	6	0
Increased AST	13	0	19	0	4	0
Hyperglycemia	19	0	18	0	17	0
Increased alkaline phosphatase	24	0	16	0	29	0
Hypophosphatemia	9	0.9 ^a	16	2	3	0

Grading according to NCI CTCAE version 4.03.

^aNo Grade 4 laboratory abnormalities were reported.

Updated safety information from 357 patients treated with AFINITOR DISPERZ for a median duration of 48 weeks identified the following additional notable adverse reactions: hypersensitivity (0.6%), angioedema (0.3%), and ovarian cyst (0.3%).

6.2 Postmarketing Experience

The following adverse reactions have been identified during post approval use of AFINITOR/AFINITOR DISPERZ. Because these reactions are reported voluntarily from a population of uncertain size, it is not always possible to reliably estimate frequency or establish a causal relationship to drug exposure:

- *Blood and lymphatic disorders:* Thrombotic microangiopathy
- *Cardiac:* Cardiac failure with some cases reported with pulmonary hypertension (including pulmonary arterial hypertension) as a secondary event

- *Gastrointestinal*: Acute pancreatitis
- *Hepatobiliary*: Cholecystitis and cholelithiasis
- *Infections*: Sepsis and septic shock
- *Nervous System*: Reflex sympathetic dystrophy
- *Vascular*: Arterial thrombotic events

7 DRUG INTERACTIONS

7.1 Effect of Other Drugs on AFINITOR/AFINITOR DISPERZ

Inhibitors

Avoid the concomitant use of P-gp and strong CYP3A4 inhibitors [*see Dosage and Administration (2.11), Clinical Pharmacology (12.3)*].

Reduce the dose for patients taking AFINITOR/AFINITOR DISPERZ with a P-gp and moderate CYP3A4 inhibitor as recommended [*see Dosage and Administration (2.11), Clinical Pharmacology (12.3)*].

Inducers

Increase the dose for patients taking AFINITOR/AFINITOR DISPERZ with a P-gp and strong CYP3A4 inducer as recommended [*see Dosage and Administration (2.12), Clinical Pharmacology (12.3)*].

7.2 Effects of Combination Use of Angiotensin Converting Enzyme (ACE) Inhibitors

Patients taking concomitant ACE inhibitors with AFINITOR/AFINITOR DISPERZ may be at increased risk for angioedema. Avoid the concomitant use of ACE inhibitors with AFINITOR/AFINITOR DISPERZ [*see Warnings and Precautions (5.4)*].

8 USE IN SPECIFIC POPULATIONS

8.1 Pregnancy

Risk Summary

Based on animal studies and the mechanism of action [*see Clinical Pharmacology (12.1)*], AFINITOR/AFINITOR DISPERZ can cause fetal harm when administered to a pregnant woman. There are limited case reports of AFINITOR use in pregnant women; however, these reports are not sufficient to inform about risks of birth defects or miscarriage. In animal studies, everolimus caused embryo-fetal toxicities in rats when administered during the period of organogenesis at maternal exposures that were lower than human exposures at the recommended dose of AFINITOR 10 mg orally once daily (*see Data*). Advise pregnant women of the potential risk to the fetus.

In the U.S. general population, the estimated background risk of major birth defects and miscarriage is 2% to 4% and 15% to 20% of clinically recognized pregnancies, respectively.

Data

Animal Data

In animal reproductive studies, oral administration of everolimus to female rats before mating and through organogenesis induced embryo-fetal toxicities, including increased resorption, pre-implantation and post-implantation loss, decreased numbers of live fetuses, malformation (e.g., sternal cleft), and retarded skeletal development. These effects occurred in the absence of maternal toxicities. Embryo-fetal toxicities in rats occurred at doses ≥ 0.1 mg/kg (0.6 mg/m²) with resulting exposures of approximately 4% of the human exposure at the recommended dose of AFINITOR 10 mg orally once daily based on area under the curve (AUC). In rabbits, embryo-toxicity evident as an increase in resorptions occurred at an oral dose of 0.8 mg/kg (9.6 mg/m²), approximately 1.6 times the recommended dose of AFINITOR 10 mg orally once daily or the median dose administered to patients with tuberous sclerosis complex (TSC)-associated subependymal giant cell

astrocytoma (SEGA), and 1.3 times the median dose administered to patients with TSC-associated partial-onset seizures based on BSA. The effect in rabbits occurred in the presence of maternal toxicities.

In a pre- and post-natal development study in rats, animals were dosed from implantation through lactation. At the dose of 0.1 mg/kg (0.6 mg/m²), there were no adverse effects on delivery and lactation or signs of maternal toxicity; however, there were reductions in body weight (up to 9% reduction from the control) and in survival of offspring (~5% died or missing). There were no drug-related effects on the developmental parameters (morphological development, motor activity, learning, or fertility assessment) in the offspring.

8.2 Lactation

Risk Summary

There are no data on the presence of everolimus or its metabolites in human milk, the effects of everolimus on the breastfed infant or on milk production. Everolimus and its metabolites passed into the milk of lactating rats at a concentration 3.5 times higher than in maternal serum. Because of the potential for serious adverse reactions in breastfed infants from everolimus, advise women not to breastfeed during treatment with AFINITOR/AFINITOR DISPERZ and for 2 weeks after the last dose.

8.3 Females and Males of Reproductive Potential

Pregnancy Testing

Verify the pregnancy status of females of reproductive potential prior to starting AFINITOR/AFINITOR DISPERZ [*see Use in Specific Population (8.1)*].

Contraception

AFINITOR/AFINITOR DISPERZ can cause fetal harm when administered to pregnant women [*see Use in Specific Populations (8.1)*].

Females: Advise female patients of reproductive potential to use effective contraception during treatment with AFINITOR/AFINITOR DISPERZ and for 8 weeks after the last dose.

Males: Advise male patients with female partners of reproductive potential to use effective contraception during treatment with AFINITOR/AFINITOR DISPERZ and for 4 weeks after the last dose.

Infertility

Females: Menstrual irregularities, secondary amenorrhea, and increases in luteinizing hormone (LH) and follicle stimulating hormone (FSH) occurred in female patients taking AFINITOR/AFINITOR DISPERZ. Based on these findings, AFINITOR/AFINITOR DISPERZ may impair fertility in female patients [*see Adverse Reactions (6.1), Nonclinical Toxicology (13.1)*].

Males: Cases of reversible azoospermia have been reported in male patients taking AFINITOR. In male rats, sperm motility, sperm count, plasma testosterone levels and fertility were diminished at AUC similar to those of the clinical dose of AFINITOR 10 mg orally once daily. Based on these findings, AFINITOR/AFINITOR DISPERZ may impair fertility in male patients [*see Nonclinical Toxicology (13.1)*].

8.4 Pediatric Use

TSC-Associated SEGA

The safety and effectiveness of AFINITOR/AFINITOR DISPERZ have been established in pediatric patients age 1 year and older with TSC-associated SEGA that requires therapeutic intervention but cannot be curatively resected. Use of AFINITOR/AFINITOR DISPERZ for this indication is supported by evidence from a randomized, double-blind, placebo-controlled trial in adult and pediatric patients (EXIST-1); an open-label, single-arm trial in adult and pediatric patients (Study 2485); and additional pharmacokinetic data in pediatric patients [*see Adverse Reactions (6.1), Clinical Pharmacology (12.3), Clinical Studies (14.5)*]. The safety and effectiveness of AFINITOR/AFINITOR DISPERZ have not been established in pediatric patients less than 1 year of age with TSC-associated SEGA.

In EXIST-1, the incidence of infections and serious infections were reported at a higher frequency in patients < 6 years of age. Ninety-six percent of 23 AFINITOR-treated patients < 6 years had at least one infection compared to 67% of 55 AFINITOR-treated patients ≥ 6 years. Thirty-five percent of 23 AFINITOR-treated patients < 6 years of age had at least 1 serious infection compared to 7% of 55 AFINITOR-treated patients ≥ 6 years.

Although a conclusive determination cannot be made due to the limited number of patients and lack of a comparator arm in the open label follow-up periods of EXIST-1 and Study 2485, AFINITOR did not appear to adversely impact growth and pubertal development in the 115 pediatric patients treated with AFINITOR for a median duration of 4.1 years.

TSC-Associated Partial-Onset Seizures

The safety and effectiveness of AFINITOR DISPERZ has been established for the adjunctive treatment of pediatric patients aged 2 years and older with TSC-associated partial-onset seizures. Use of AFINITOR DISPERZ for this indication is supported by evidence from a randomized, double-blind, placebo-controlled trial in adult and pediatric patients (EXIST-3) with additional pharmacokinetic data in pediatric patients [*see Adverse Reactions (6.1), Clinical Pharmacology (12.3), Clinical Studies (14.6)*]. The safety and effectiveness of AFINITOR DISPERZ and AFINITOR have not been established for the adjunctive treatment of pediatric patients less than 2 years of age with TSC-associated partial-onset seizures.

The incidence of infections and serious infections were reported at a higher frequency in patients < 6 years of age compared to patients ≥ 6 years old. Seventy-seven percent of 70 AFINITOR DISPERZ-treated patients < 6 years had at least one infection, compared to 53% of 177 AFINITOR DISPERZ-treated patients ≥ 6 years. Sixteen percent of 70 AFINITOR DISPERZ-treated patients < 6 years of age had at least 1 serious infection, compared to 4% of 177 AFINITOR DISPERZ-treated patients ≥ 6 years of age. Two fatal cases due to infections were reported in pediatric patients.

Other Indications

The safety and effectiveness of AFINITOR/AFINITOR DISPERZ in pediatric patients have not been established in:

- Hormone receptor-positive, HER2-negative breast cancer
- Neuroendocrine tumors (NET)
- Renal cell carcinoma (RCC)
- TSC-associated renal angiomyolipoma

8.5 Geriatric Use

In BOLERO-2, 40% of patients with breast cancer treated with AFINITOR were ≥ 65 years of age, while 15% were ≥ 75 years of age. No overall differences in effectiveness were observed between elderly and younger patients. The incidence of deaths due to any cause within 28 days of the last AFINITOR dose was 6% in patients ≥ 65 years of age compared to 2% in patients < 65 years of age. Adverse reactions leading to permanent treatment discontinuation occurred in 33% of patients ≥ 65 years of age compared to 17% in patients < 65 years of age.

In RECORD-1, 41% of patients with renal cell carcinoma treated with AFINITOR were ≥ 65 years of age, while 7% were ≥ 75 years of age. In RADIANT-3, 30% of patients with PNET treated with AFINITOR were ≥ 65 years of age, while 7% were ≥ 75 years of age. No overall differences in safety or effectiveness were observed between elderly and younger patients.

8.6 Hepatic Impairment

AFINITOR/AFINITOR DISPERZ exposure may increase in patients with hepatic impairment [*see Clinical Pharmacology (12.3)*].

For patients with breast cancer, NET, RCC, and TSC-associated renal angiomyolipoma who have hepatic impairment, reduce the AFINITOR dose as recommended [*see Dosage and Administration (2.10)*].

For patients with TSC-associated SEGA and TSC-associated partial-onset seizures who have severe hepatic impairment (Child-Pugh C), reduce the starting dose of AFINITOR/AFINITOR DISPERZ as recommended and adjust the dose based on everolimus trough concentrations [see *Dosage and Administration (2.8, 2.10)*].

11 DESCRIPTION

AFINITOR (everolimus) and AFINITOR DISPERZ (everolimus tablets for oral suspension) are kinase inhibitors.

The chemical name of everolimus is (1R,9S,12S,15R,16E,18R,19R,21R,23S,24E,26E,28E,30S,32S,35R)-1,18-dihydroxy-12-[(1R)-2-[(1S,3R,4R)-4-(2-hydroxyethoxy)-3-methoxycyclohexyl]-1-methylethyl]-19,30-dimethoxy-15,17,21,23,29,35-hexamethyl-11,36-dioxo-4-aza-tricyclo[30.3.1.0^{4,9}]hexatriaconta-16,24,26,28-tetraene-2,3,10,14,20-pentaone. The molecular formula is C₅₃H₈₃NO₁₄ and the molecular weight is 958.2 g/mol. The structural formula is:

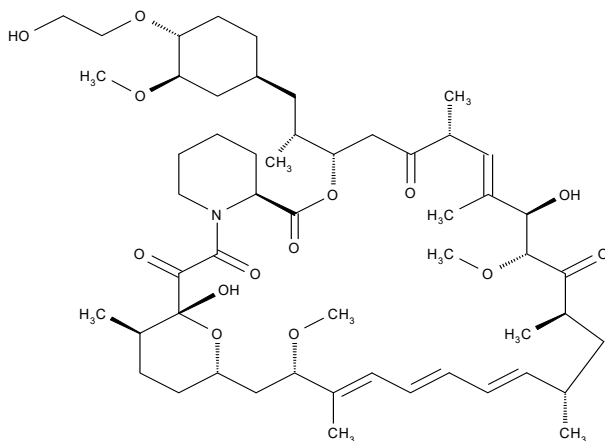

AFINITOR for oral administration contains 2.5 mg, 5 mg, 7.5 mg, or 10 mg of everolimus and the following inactive ingredients: anhydrous lactose, butylated hydroxytoluene, crospovidone, hypromellose, lactose monohydrate, and magnesium stearate.

AFINITOR DISPERZ for oral administration contains 2 mg, 3 mg, or 5 mg of everolimus and the following inactive ingredients: butylated hydroxytoluene, colloidal silicon dioxide, crospovidone, hypromellose, lactose monohydrate, magnesium stearate, mannitol, and microcrystalline cellulose.

12 CLINICAL PHARMACOLOGY

12.1 Mechanism of Action

Everolimus is an inhibitor of mammalian target of rapamycin (mTOR), a serine-threonine kinase, downstream of the PI3K/AKT pathway. The mTOR pathway is dysregulated in several human cancers and in tuberous sclerosis complex (TSC). Everolimus binds to an intracellular protein, FKBP-12, resulting in an inhibitory complex formation with mTOR complex 1 (mTORC1) and thus inhibition of mTOR kinase activity. Everolimus reduced the activity of S6 ribosomal protein kinase (S6K1) and eukaryotic initiation factor 4E-binding protein (4E-BP1), downstream effectors of mTOR, involved in protein synthesis. S6K1 is a substrate of mTORC1 and phosphorylates the activation domain 1 of the estrogen receptor which results in ligand-independent activation of the receptor. In addition, everolimus inhibited the expression of hypoxia-inducible factor (e.g., HIF-1) and reduced the expression of vascular endothelial growth factor (VEGF). Inhibition of mTOR by everolimus has been shown to reduce cell proliferation, angiogenesis, and glucose uptake in in vitro and/or in vivo studies.

Constitutive activation of the PI3K/Akt/mTOR pathway can contribute to endocrine resistance in breast cancer. In vitro studies show that estrogen-dependent and HER2+ breast cancer cells are sensitive to the inhibitory effects of everolimus, and that combination treatment with everolimus and Akt, HER2, or aromatase inhibitors enhances the anti-tumor activity of everolimus in a synergistic manner.

Two regulators of mTORC1 signaling are the oncogene suppressors tuberlin-sclerosis complexes 1 and 2 (*TSC1*, *TSC2*). Loss or inactivation of either *TSC1* or *TSC2* leads to activation of downstream signaling. In TSC, a genetic disorder, inactivating mutations in either the *TSC1* or the *TSC2* gene lead to hamartoma formation throughout the body as well as seizures and epileptogenesis. Overactivation of mTOR results in neuronal dysplasia, aberrant axonogenesis and dendrite formation, increased excitatory synaptic currents, reduced myelination, and disruption of the cortical laminar structure causing abnormalities in neuronal development and function. Treatment with an mTOR inhibitor in animal models of mTOR dysregulation in the brain resulted in seizure suppression, prevention of the development of new-onset seizures, and prevention of premature death.

12.2 Pharmacodynamics

Exposure-Response Relationship

In patients with TSC-associated subependymal giant cell astrocytoma (SEGA), the magnitude of the reduction in SEGA volume was correlated with the everolimus trough concentration.

In patients with TSC-associated partial-onset seizures, the magnitude of the reduction in absolute seizure frequency was correlated with the everolimus trough concentration.

Cardiac Electrophysiology

In a randomized, placebo-controlled, cross-over study, 59 healthy subjects were administered a single oral dose of AFINITOR (20 mg and 50 mg) and placebo. AFINITOR at single doses up to 50 mg did not prolong the QT/QTc interval.

12.3 Pharmacokinetics

Absorption

After administration of AFINITOR in patients with advanced solid tumors, peak everolimus concentrations are reached 1 to 2 hours after administration of oral doses ranging from 5 mg to 70 mg. Following single doses, C_{max} is dose-proportional with daily dosing between 5 mg and 10 mg. With single doses of 20 mg and higher, the increase in C_{max} is less than dose-proportional; however, AUC shows dose-proportionality over the 5 mg to 70 mg dose range. Steady-state was achieved within 2 weeks following once-daily dosing.

In patients with TSC-associated SEGA, everolimus C_{min} was approximately dose-proportional within the dose range from 1.35 mg/m² to 14.4 mg/m².

Effect of Food: In healthy subjects, a high-fat meal (containing approximately 1000 calories and 55 grams of fat) reduced systemic exposure to AFINITOR 10 mg (as measured by AUC) by 22% and the peak blood concentration C_{max} by 54%. Light-fat meals (containing approximately 500 calories and 20 grams of fat) reduced AUC by 32% and C_{max} by 42%.

In healthy subjects who received 9 mg of AFINITOR DISPERZ, high-fat meals (containing approximately 1000 calories and 55 grams of fat) reduced everolimus AUC by 12% and C_{max} by 60% and low-fat meals (containing approximately 500 calories and 20 grams of fat) reduced everolimus AUC by 30% and C_{max} by 50%.

Relative Bioavailability: The AUC_{inf} of everolimus was equivalent between AFINITOR DISPERZ and AFINITOR; the C_{max} of everolimus in the AFINITOR DISPERZ dosage form was 20% to 36% lower than that of AFINITOR. The predicted trough concentrations at steady-state were similar after daily administration.

Distribution

The blood-to-plasma ratio of everolimus, which is concentration-dependent over the range of 5 to 5000 ng/mL, is 17% to 73%. The amount of everolimus confined to the plasma is approximately 20% at blood concentrations observed in cancer patients given AFINITOR 10 mg orally once daily. Plasma protein binding is approximately 74% both in healthy subjects and in patients with moderate hepatic impairment.

Elimination

The mean elimination half-life of everolimus is approximately 30 hours.

Metabolism: Everolimus is a substrate of CYP3A4. Following oral administration, everolimus is the main circulating component in human blood. Six main metabolites of everolimus have been detected in human blood, including three monohydroxylated metabolites, two hydrolytic ring-opened products, and a phosphatidylcholine conjugate of everolimus. These metabolites were also identified in animal species used in toxicity studies, and showed approximately 100-times less activity than everolimus itself.

Excretion: No specific elimination studies have been undertaken in cancer patients. Following the administration of a 3 mg single dose of radiolabeled everolimus in patients who were receiving cyclosporine, 80% of the radioactivity was recovered from the feces, while 5% was excreted in the urine. The parent substance was not detected in urine or feces.

Specific Populations

No relationship was apparent between oral clearance and age or sex in patients with cancer.

Patients with Renal Impairment: No significant influence of creatinine clearance (25 to 178 mL/min) was detected on oral clearance (CL/F) of everolimus.

Patients with Hepatic Impairment: Compared to normal subjects, there was a 1.8-fold, 3.2-fold, and 3.6-fold increase in AUC for subjects with mild (Child-Pugh class A), moderate (Child-Pugh class B), and severe (Child-Pugh class C) hepatic impairment, respectively. In another study, the average AUC of everolimus in subjects with moderate hepatic impairment (Child-Pugh class B) was twice that found in subjects with normal hepatic function [see *Dosage and Administration (2.10), Use in Specific Populations (8.6)*].

Pediatric Patients: In patients with TSC-associated SEGA or TSC-associated partial-onset seizures, the mean C_{\min} values normalized to mg/m^2 dose in pediatric patients (< 18 years of age) were lower than those observed in adults, suggesting that everolimus clearance adjusted to BSA was higher in pediatric patients as compared to adults.

Race or Ethnicity: Based on a cross-study comparison, Japanese patients had on average exposures that were higher than non-Japanese patients receiving the same dose. Oral clearance (CL/F) is on average 20% higher in Black patients than in White patients.

Drug Interaction Studies

Effect of CYP3A4 and P-glycoprotein (P-gp) Inhibitors on Everolimus: Everolimus exposure increased when AFINITOR was coadministered with:

- ketoconazole (a P-gp and strong CYP3A4 inhibitor) - C_{\max} and AUC increased by 3.9- and 15-fold, respectively.
- erythromycin (a P-gp and moderate CYP3A4 inhibitor) - C_{\max} and AUC increased by 2- and 4.4-fold, respectively.
- verapamil (a P-gp and moderate CYP3A4 inhibitor) - C_{\max} and AUC increased by 2.3- and 3.5-fold, respectively.

Effect of CYP3A4 and P-gp Inducers on Everolimus: The coadministration of AFINITOR with rifampin, a P-gp and strong inducer of CYP3A4, decreased everolimus AUC by 63% and C_{\max} by 58% compared to AFINITOR alone [see *Dosage and Administration (2.12)*].

Effect of Everolimus on CYP3A4 Substrates: No clinically significant pharmacokinetic interactions were observed between AFINITOR and the HMG-CoA reductase inhibitors atorvastatin (a CYP3A4 substrate), pravastatin (a non-CYP3A4 substrate), and simvastatin (a CYP3A4 substrate).

The coadministration of an oral dose of midazolam (sensitive CYP3A4 substrate) with AFINITOR resulted in a 25% increase in midazolam C_{\max} and a 30% increase in midazolam $\text{AUC}_{0-\text{inf}}$.

The coadministration of AFINITOR with exemestane increased exemestane C_{\min} by 45% and $C_{2\text{h}}$ by 64%; however, the corresponding estradiol levels at steady state (4 weeks) were not different between the 2 treatment arms. No increase in adverse reactions related to exemestane was observed in patients with hormone receptor-positive, HER2-negative advanced breast cancer receiving the combination.

The coadministration of AFINITOR with long acting octreotide increased octreotide C_{\min} by approximately 50%.

Effect of Everolimus on Antiepileptic drugs (AEDs): Everolimus increased pre-dose concentrations of the carbamazepine, clobazam, oxcarbazepine, and clobazam's metabolite N-desmethyloclobazam by about 10%. Everolimus had no impact on pre-dose concentrations of AEDs that are substrates of CYP3A4 (e.g., clonazepam and zonisamide) or other AEDs, including valproic acid, topiramate, phenobarbital, and phenytoin.

13 NONCLINICAL TOXICOLOGY

13.1 Carcinogenesis, Mutagenesis, Impairment of Fertility

Administration of everolimus for up to 2 years did not indicate oncogenic potential in mice and rats up to the highest doses tested (0.9 mg/kg) corresponding respectively to 3.9 and 0.2 times the estimated human exposure based on AUC at the recommended dose of AFINITOR 10 mg orally once daily.

Everolimus was not genotoxic in a battery of in vitro assays (Ames mutation test in *Salmonella*, mutation test in L5178Y mouse lymphoma cells, and chromosome aberration assay in V79 Chinese hamster cells). Everolimus was not genotoxic in an in vivo mouse bone marrow micronucleus test at doses up to 500 mg/kg/day (1500 mg/m²/day, approximately 255-fold the recommended dose of AFINITOR 10 mg orally once daily, and approximately 200-fold the median dose administered to patients with TSC-associated SEGA and TSC-associated partial-onset seizures, based on the BSA), administered as 2 doses, 24 hours apart.

Based on non-clinical findings, AFINITOR/AFINITOR DISPERZ may impair male fertility. In a 13-week male fertility study in rats, testicular morphology was affected at doses of 0.5 mg/kg and above. Sperm motility, sperm count, and plasma testosterone levels were diminished in rats treated with 5 mg/kg. The exposures at these doses (52 ng•hr/mL and 414 ng•hr/mL, respectively) were within the range of human exposure at the recommended dose of AFINITOR 10 mg orally once daily (560 ng•hr/mL) and resulted in infertility in the rats at 5 mg/kg. Effects on male fertility occurred at AUC_{0-24h} values 10% to 81% lower than human exposure at the recommended dose of AFINITOR 10 mg orally once daily. After a 10-13 week non-treatment period, the fertility index increased from zero (infertility) to 60%.

Oral doses of everolimus in female rats at doses \geq 0.1 mg/kg (approximately 4% the human exposure based on AUC at the recommended dose of AFINITOR 10 mg orally once daily) resulted in increased incidence of pre-implantation loss, suggesting that the drug may reduce female fertility.

13.2 Animal Toxicology and/or Pharmacology

In juvenile rat toxicity studies, dose-related delayed attainment of developmental landmarks including delayed eye-opening, delayed reproductive development in males and females and increased latency time during the learning and memory phases were observed at doses as low as 0.15 mg/kg/day.

14 CLINICAL STUDIES

14.1 Hormone Receptor-Positive, HER2-Negative Breast Cancer

A randomized, double-blind, multicenter study (BOLERO-2, NCT00863655) of AFINITOR in combination with exemestane vs. placebo in combination with exemestane was conducted in 724 postmenopausal women with estrogen receptor-positive, HER2-negative advanced breast cancer with recurrence or progression following prior therapy with letrozole or anastrozole. Randomization was stratified by documented sensitivity to prior hormonal therapy (yes vs. no) and by the presence of visceral metastasis (yes vs. no). Sensitivity to prior hormonal therapy was defined as either (1) documented clinical benefit (complete response [CR], partial response [PR], stable disease \geq 24 weeks) to at least one prior hormonal therapy in the advanced setting or (2) at least 24 months of adjuvant hormonal therapy prior to recurrence. Patients were permitted to have received 0-1 prior lines of chemotherapy for advanced disease. The major efficacy outcome measure was progression-free survival (PFS) evaluated by RECIST (Response Evaluation Criteria in Solid Tumors), based on investigator (local radiology) assessment. Other outcome measures included overall survival (OS) and objective response rate (ORR).

Patients were randomized 2:1 to AFINITOR 10 mg orally once daily in combination with exemestane 25 mg once daily (n = 485) or to placebo in combination with exemestane 25 mg orally once daily (n = 239). The two treatment groups were generally balanced with respect to baseline demographics and disease characteristics. Patients were not permitted to cross over to AFINITOR at the time of disease progression.

The trial demonstrated a statistically significant improvement in PFS by investigator assessment (Table 20 and Figure 1). The results of the PFS analysis based on independent central radiological assessment were consistent with the investigator assessment. PFS results were also consistent across the subgroups of age, race, presence and extent of visceral metastases, and sensitivity to prior hormonal therapy.

ORR was higher in the AFINITOR in combination with exemestane arm vs. the placebo in combination with exemestane arm (Table 20). There were 3 complete responses (0.6%) and 58 partial responses (12%) in the AFINITOR arm. There were no complete responses and 4 partial responses (1.7%) in the placebo in combination with exemestane arm.

After a median follow-up of 39.3 months, there was no statistically significant difference in OS between the AFINITOR in combination with exemestane arm and the placebo in combination with exemestane arm [HR 0.89 (95% CI: 0.73, 1.10)].

Table 20: Efficacy Results in Hormone-Receptor Positive, HER-2 Negative Breast Cancer in BOLERO-2

Analysis	AFINITOR with Exemestane N = 485	Placebo with Exemestane N = 239	Hazard ratio	p-value
Median progression-free survival (months, 95% CI)				
Investigator radiological review	7.8 (6.9, 8.5)	3.2 (2.8, 4.1)	0.45 ^a (0.38, 0.54)	< 0.0001 ^b
Independent radiological review	11.0 (9.7, 15.0)	4.1 (2.9, 5.6)	0.38 ^a (0.3, 0.5)	< 0.0001 ^b
Best overall response (% , 95% CI)				
Objective response rate (ORR) ^c	12.6% (9.8, 15.9)	1.7% (0.5, 4.2)	n/a ^d	

^aHazard ratio is obtained from the stratified Cox proportional-hazards model by sensitivity to prior hormonal therapy and presence of visceral metastasis.
^bp-value is obtained from the one-sided log-rank test stratified by sensitivity to prior hormonal therapy and presence of visceral metastasis.
^cObjective response rate = proportion of patients with CR or PR.
^dNot applicable.

Figure 1: Kaplan-Meier Curves for Progression-Free Survival by Investigator Radiological Review in Hormone Receptor-Positive, HER-2 Negative Breast Cancer in BOLERO-2

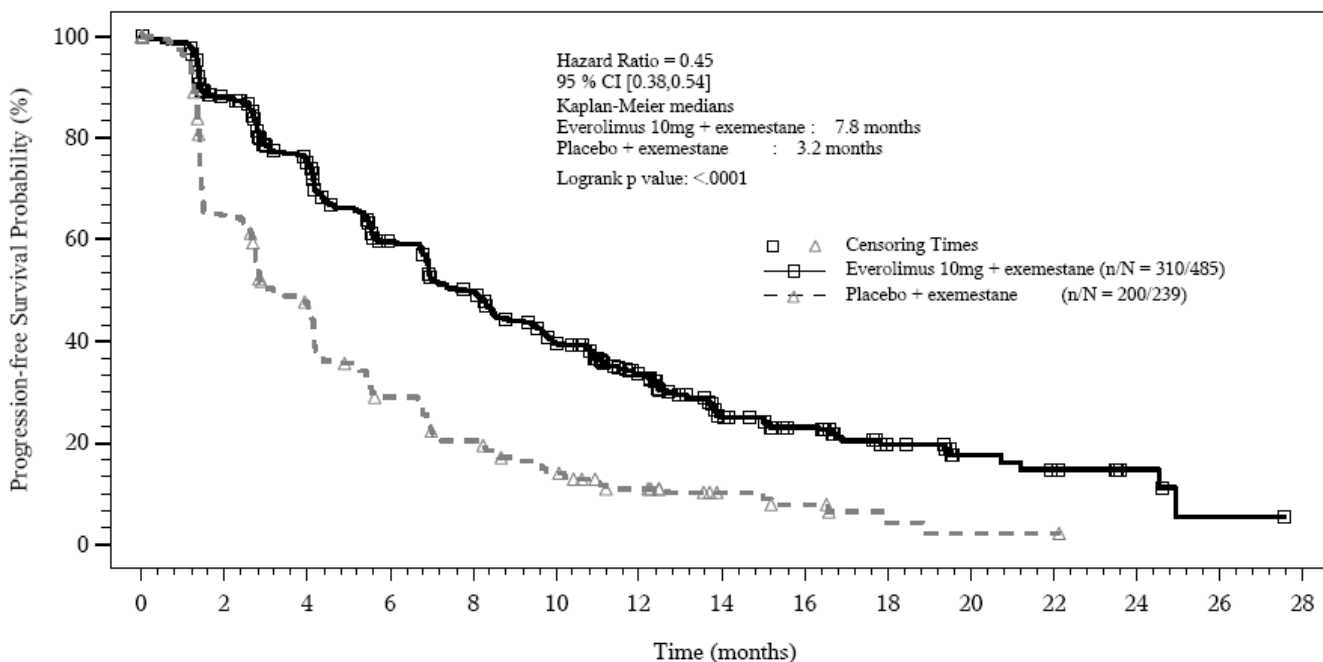

14.2 Neuroendocrine Tumors (NET)

Pancreatic Neuroendocrine Tumors (PNET)

A randomized, double-blind, multi-center trial (RADIANT-3, NCT00510068) of AFINITOR in combination with best supportive care (BSC) compared to placebo in combination with BSC was conducted in patients with locally advanced or metastatic advanced PNET and disease progression within the prior 12 months. Patients were stratified by prior cytotoxic chemotherapy (yes vs. no) and WHO performance status (0 vs. 1 and 2). Treatment with somatostatin analogs was allowed as part of BSC. The major efficacy outcome was PFS evaluated by RECIST. After documented radiological progression, patients randomized to placebo could receive open-label AFINITOR. Other outcome measures included ORR, response duration, and OS.

Patients were randomized 1:1 to receive either AFINITOR 10 mg once daily (n = 207) or placebo (n = 203). Demographics were well balanced (median age 58 years, 55% male, 79% White). Of the 203 patients randomized to BSC, 172 patients (85%) received AFINITOR following documented radiologic progression.

The trial demonstrated a statistically significant improvement in PFS (Table 21 and Figure 2). PFS improvement was observed across all patient subgroups, irrespective of prior somatostatin analog use. The PFS results by investigator radiological review, central radiological review and adjudicated radiological review are shown below in Table 21.

Table 21: Progression-Free Survival Results in PNET in RADIANT-3

Analysis	N	AFINITOR N = 207	Placebo N = 203	Hazard Ratio (95% CI)	p-value
	410	Median progression-free survival (months) (95% CI)			
Investigator radiological review		11.0 (8.4, 13.9)	4.6 (3.1, 5.4)	0.35 (0.27, 0.45)	< 0.001
Central radiological review		13.7	5.7	0.38	< 0.001

Analysis	N	AFINITOR N = 207 (11.2, 18.8)	Placebo N = 203 (5.4, 8.3)	Hazard Ratio (95% CI) (0.28, 0.51)	p-value
Adjudicated radiological review ^a		11.4 (10.8, 14.8)	5.4 (4.3, 5.6)	0.34 (0.26, 0.44)	< 0.001

^aIncludes adjudication for discrepant assessments between investigator radiological review and central radiological review.

Figure 2: Kaplan-Meier Curves for Progression-Free Survival by Investigator Radiological Review in PNET in RADIANT-3

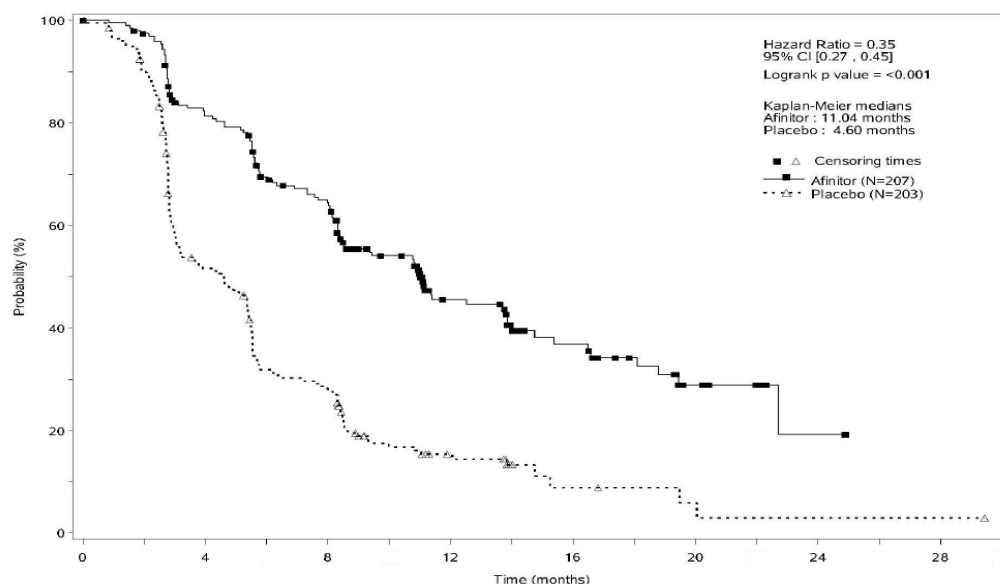

Investigator-determined response rate was 4.8% in the AFINITOR arm and there were no complete responses. OS was not statistically significantly different between arms [HR = 0.94 (95% CI 0.73, 1.20); p = 0.30].

NET of Gastrointestinal (GI) or Lung Origin

A randomized, double-blind, multicenter study (RADIANT-4, NCT01524783) of AFINITOR in combination with BSC compared to placebo in combination with BSC was conducted in patients with unresectable, locally advanced or metastatic, well differentiated, non-functional NET of GI (excluding pancreatic) or lung origin. The study required that patients had well-differentiated (low or intermediate grade) histology, no prior or current history of carcinoid symptoms, and evidence of disease progression within 6 months prior to randomization. Patients were randomized 2:1 to receive either AFINITOR 10 mg once daily or placebo, and stratified by prior somatostatin analog use (yes vs. no), tumor origin and WHO performance status (0 vs. 1). The major efficacy outcome measure was PFS based on independent radiological assessment evaluated by RECIST. Additional efficacy outcome measures were OS and ORR.

A total of 302 patients were randomized, 205 to the AFINITOR arm and 97 to the placebo arm. The median age was 63 years (22 to 86 years); 47% were male; 76% were White; 74% had WHO performance status of 0 and 26% had WHO performance status of 1. The most common primary sites of tumor were lung (30%), ileum (24%), and rectum (13%).

The study demonstrated a statistically significant improvement in PFS per independent radiological review (Table 22 and Figure 3). There was no statistically significant difference in OS at the planned interim analysis.

Table 22: Progression-Free Survival in Neuroendocrine Tumors of Gastrointestinal or Lung Origin in RADIANT-4

	AFINITOR N = 205	Placebo N = 97
Progression-Free Survival		
Number of Events	113 (55%)	65 (67%)
Progressive Disease	104 (51%)	60 (62%)
Death	9 (4%)	5 (5%)
Median PFS in months (95% CI)	11.0 (9.2, 13.3)	3.9 (3.6, 7.4)
Hazard Ratio (95% CI) ^a	0.48 (0.35, 0.67)	
p-value ^b	< 0.001	
Overall Response Rate	2%	1%

^aHazard ratio is obtained from the stratified Cox model.

^bp-value is obtained from the stratified log-rank test.

Figure 3: Kaplan-Meier Curves for Progression-Free Survival in NET of GI or Lung Origin in RADIANT-4

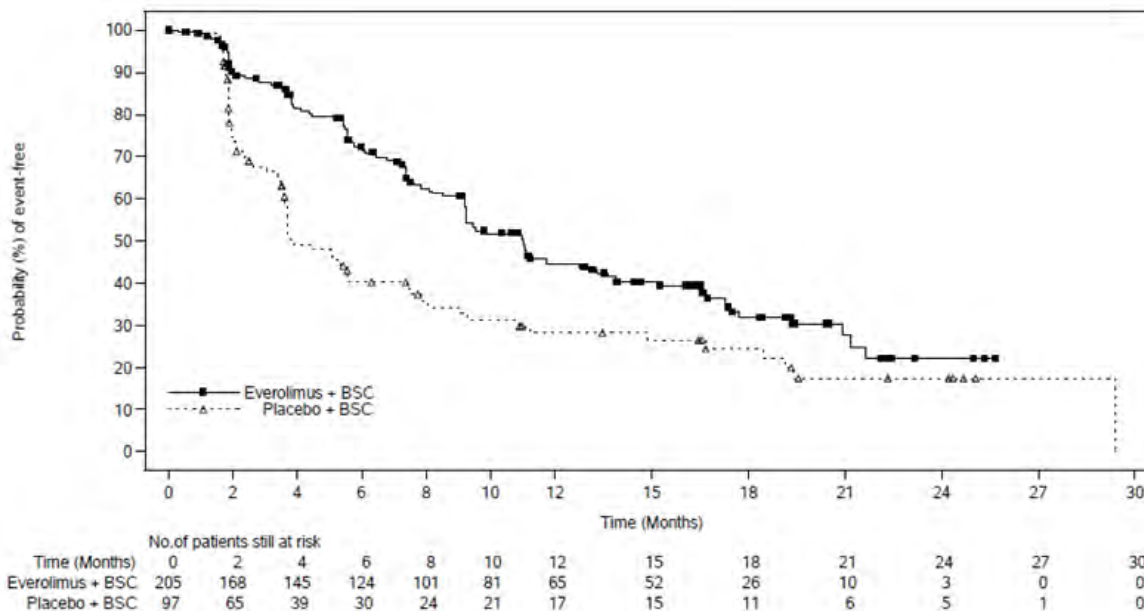

Lack of Efficacy in Locally Advanced or Metastatic Functional Carcinoid Tumors

The safety and effectiveness of AFINITOR in patients with locally advanced or metastatic functional carcinoid tumors have not been demonstrated. In a randomized (1:1), double-blind, multi-center trial (RADIANT-2, NCT00412061) in 429 patients with carcinoid tumors, AFINITOR in combination with long-acting octreotide (Sandostatin LAR[®]) was compared to placebo in combination with long-acting octreotide. After documented radiological progression, patients on the placebo arm could receive AFINITOR; of those randomized to placebo, 67% received open-label AFINITOR in combination with long-acting octreotide. The study did not meet its major efficacy outcome measure of a statistically significant improvement in PFS and the final analysis of OS favored the placebo in combination with long-acting octreotide arm.

14.3 Renal Cell Carcinoma (RCC)

An international, multi-center, randomized, double-blind trial (RECORD-1, NCT00410124) comparing AFINITOR 10 mg once daily and placebo, both in conjunction with BSC, was conducted in patients with metastatic RCC whose disease had progressed despite prior treatment with sunitinib, sorafenib, or both sequentially. Prior therapy with

bevacizumab, interleukin 2, or interferon- α was also permitted. Randomization was stratified according to prognostic score and prior anticancer therapy. The major efficacy outcome measure for the trial was PFS evaluated by RECIST, based on a blinded, independent, central radiologic review. After documented radiological progression, patients randomized to placebo could receive open-label AFINITOR. Other outcome measures included OS.

In total, 416 patients were randomized 2:1 to receive AFINITOR (n = 277) or placebo (n = 139). Demographics were well balanced between the arms (median age 61 years; 77% male, 88% White, 74% received prior sunitinib or sorafenib, and 26% received both sequentially).

AFINITOR was superior to placebo for PFS (Table 23 and Figure 4). The treatment effect was similar across prognostic scores and prior sorafenib and/or sunitinib. Final OS results yield a hazard ratio of 0.90 (95% CI: 0.71, 1.14), with no statistically significant difference between the arms. Planned cross-over from placebo due to disease progression to open-label AFINITOR occurred in 80% of the 139 patients and may have confounded the OS benefit.

Table 23: Progression-Free Survival and Objective Response Rate by Central Radiologic Review in RCC in RECORD-1

	AFINITOR N = 277	Placebo N = 139	Hazard Ratio (95% CI)	p-value ^a
Median Progression-free Survival (95% CI)	4.9 months (4.0, 5.5)	1.9 months (1.8, 1.9)	0.33 (0.25, 0.43)	< 0.0001
Objective Response Rate	2%	0%	n/a ^b	n/a ^b

^aLog-rank test stratified by prognostic score.

^bNot applicable.

Figure 4: Kaplan-Meier Curves for Progression-Free Survival in RCC in RECORD-1

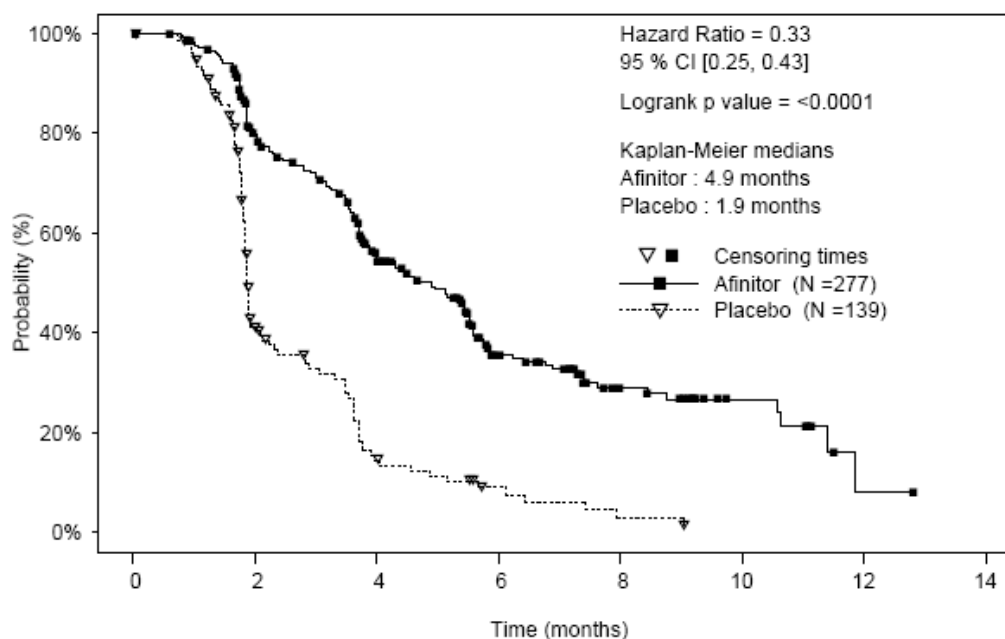

14.4 Tuberos Sclerosis Complex (TSC)-Associated Renal Angiomyolipoma

A randomized (2:1), double-blind, placebo-controlled trial (EXIST-2, NCT00790400) of AFINITOR was conducted in 118 patients with renal angiomyolipoma as a feature of TSC (n = 113) or sporadic lymphangioliomyomatosis (n = 5). The key eligibility requirements for this trial were at least one angiomyolipoma of ≥ 3 cm in longest diameter on CT/MRI based on local radiology assessment, no immediate indication for surgery, and age ≥ 18 years. Patients received AFINITOR 10 mg or matching placebo orally once daily until disease progression or unacceptable toxicity. CT or MRI

scans for disease assessment were obtained at baseline, 12, 24, and 48 weeks and annually thereafter. Clinical and photographic assessment of skin lesions were conducted at baseline and every 12 weeks thereafter until treatment discontinuation. The major efficacy outcome measure was angiomyolipoma response rate based on independent central radiology review, which was defined as a $\geq 50\%$ reduction in angiomyolipoma volume, absence of new angiomyolipoma lesion ≥ 1 cm, absence of kidney volume increase $\geq 20\%$, and no angiomyolipoma related bleeding of \geq Grade 2. Key supportive efficacy outcome measures were time to angiomyolipoma progression and skin lesion response rate. The primary analyses of efficacy outcome measures were limited to the blinded treatment period and conducted 6 months after the last patient was randomized. The comparative angiomyolipoma response rate analysis was stratified by use of enzyme-inducing antiepileptic drugs (EIAEDs) at randomization (yes vs. no).

Of the 118 patients enrolled, 79 were randomized to AFINITOR and 39 to placebo. The median age was 31 years (18 to 61 years), 34% were male, and 89% were White. At baseline, 17% of patients were receiving EIAEDs. On central radiology review at baseline, 92% of patients had at least 1 angiomyolipoma of ≥ 3 cm in longest diameter, 29% had angiomyolipomas ≥ 8 cm, 78% had bilateral angiomyolipomas, and 97% had skin lesions. The median values for the sum of all target renal angiomyolipoma lesions at baseline were 85 cm³ (9 to 1612 cm³) and 120 cm³ (3 to 4520 cm³) in the AFINITOR and placebo arms, respectively. Forty-six (39%) patients had prior renal embolization or nephrectomy. The median duration of follow-up was 8.3 months (0.7 to 24.8 months) at the time of the primary analysis.

The renal angiomyolipoma response rate was statistically significantly higher in AFINITOR-treated patients (Table 24). The median response duration was 5.3+ months (2.3+ to 19.6+ months).

There were 3 patients in the AFINITOR arm and 8 patients in the placebo arm with documented angiomyolipoma progression by central radiologic review (defined as a $\geq 25\%$ increase from nadir in the sum of angiomyolipoma target lesion volumes to a value greater than baseline, appearance of a new angiomyolipoma ≥ 1 cm in longest diameter, an increase in renal volume $\geq 20\%$ from nadir for either kidney and to a value greater than baseline, or Grade ≥ 2 angiomyolipoma-related bleeding). The time to angiomyolipoma progression was statistically significantly longer in the AFINITOR arm (HR 0.08 [95% CI: 0.02, 0.37]; $p < 0.0001$).

Table 24: Angiomyolipoma Response Rate in TSC-Associated Renal Angiomyolipoma in EXIST-2

	AFINITOR	Placebo	p-value
	N = 79	N = 39	
Primary analysis			
Angiomyolipoma response rate^a - %	41.8	0	< 0.0001
95% CI	(30.8, 53.4)	(0.0, 9.0)	

^aPer independent central radiology review.

Skin lesion response rates were assessed by local investigators for 77 patients in the AFINITOR arm and 37 patients in the placebo arm who presented with skin lesions at study entry. The skin lesion response rate was statistically significantly higher in the AFINITOR arm (26% vs. 0, $p = 0.0011$); all skin lesion responses were partial responses, defined as visual improvement in 50% to 99% of all skin lesions durable for at least 8 weeks (Physician's Global Assessment of Clinical Condition).

Patients randomized to placebo were permitted to receive AFINITOR at the time of angiomyolipoma progression or after the time of the primary analysis. After the primary analysis, patients treated with AFINITOR underwent additional follow-up CT or MRI scans to assess tumor status until discontinuation of treatment or completion of 4 years of follow-up after the last patient was randomized. A total of 112 patients (79 randomized to AFINITOR and 33 randomized to placebo) received at least one dose of AFINITOR. The median duration of AFINITOR treatment was 3.9 years (0.5 months to 5.3 years) and the median duration of follow-up was 3.9 years (0.9 months to 5.4 years). During the follow-up period after the primary analysis, 32 patients (in addition to the 33 patients identified at the time of the primary analysis) had an angiomyolipoma response based upon independent central radiology review. Among the 65 responders out of 112 patients, the median time to angiomyolipoma response was 2.9 months (2.6 to 33.8 months). Fourteen percent of the 112 patients treated with AFINITOR had angiomyolipoma progression by the end of the follow-up period. No patient

underwent a nephrectomy for angiomyolipoma progression and one patient underwent renal embolization while treated with AFINITOR.

14.5 Tuberos Sclerosis Complex (TSC)-Associated Subependymal Giant Cell Astrocytoma (SEGA)

EXIST-1

A randomized (2:1), double-blind, placebo-controlled trial (EXIST-1, NCT00789828) of AFINITOR was conducted in 117 pediatric and adult patients with SEGA and TSC. Eligible patients had at least one SEGA lesion ≥ 1 cm in longest diameter on MRI based on local radiology assessment and one or more of the following: serial radiological evidence of SEGA growth, a new SEGA lesion ≥ 1 cm in longest diameter, or new or worsening hydrocephalus. Patients randomized to the treatment arm received AFINITOR at a starting dose of 4.5 mg/m² daily, with subsequent dose adjustments as needed to achieve and maintain everolimus trough concentrations of 5 to 15 ng/mL as tolerated. AFINITOR or matched placebo continued until disease progression or unacceptable toxicity. MRI scans for disease assessment were obtained at baseline, 12, 24, and 48 weeks, and annually thereafter.

The main efficacy outcome measure was SEGA response rate based on independent central radiology review. SEGA response was defined as a $\geq 50\%$ reduction in the sum of SEGA volume relative to baseline, in the absence of unequivocal worsening of non-target SEGA lesions, a new SEGA lesion ≥ 1 cm, and new or worsening hydrocephalus. The primary analysis of SEGA response rate was limited to the blinded treatment period and conducted 6 months after the last patient was randomized. The analysis of SEGA response rate was stratified by use of enzyme-inducing antiepileptic drugs (EIAEDs) at randomization (yes vs. no).

Of the 117 patients enrolled, 78 were randomized to AFINITOR and 39 to placebo. The median age was 9.5 years (0.8 to 26 years); a total of 20 patients were < 3 years, 54 patients were 3 to < 12 years, 27 patients were 12 to < 18 years, and 16 patients were ≥ 18 years; 57% were male, and 93% were White. At baseline, 18% of patients were receiving EIAEDs. Based on central radiology review at baseline, 98% of patients had at least one SEGA lesion ≥ 1.0 cm in longest diameter, 79% had bilateral SEGAs, 43% had ≥ 2 target SEGA lesions, 26% had growth in or into the inferior surface of the ventricle, 9% had evidence of growth beyond the subependymal tissue adjacent to the ventricle, and 7% had radiographic evidence of hydrocephalus. The median values for the sum of all target SEGA lesions at baseline were 1.63 cm³ (0.18 to 25.15 cm³) and 1.30 cm³ (0.32 to 9.75 cm³) in the AFINITOR and placebo arms respectively. Eight (7%) patients had prior SEGA-related surgery. The median duration of follow-up was 8.4 months (4.6 to 17.2 months) at the time of primary analysis.

The SEGA response rate was statistically significantly higher in AFINITOR-treated patients (Table 25). At the time of the primary analysis, all SEGA responses were ongoing and the median duration of response was 5.3 months (2.1 to 8.4 months).

With a median follow-up of 8.4 months, SEGA progression was detected in 15.4% of the 39 patients randomized to receive placebo and none of the 78 patients randomized to receive AFINITOR. No patient in either treatment arm required surgical intervention.

Table 25: Subependymal Giant Cell Astrocytoma Response Rate in TSC-Associated SEGA in EXIST-1

	AFINITOR N = 78	Placebo N = 39	p-value
Primary analysis			
SEGA response rate ^a - (%)	35	0	< 0.0001
95% CI	24, 46	0, 9	

^aPer independent central radiology review.

Patients randomized to placebo were permitted to receive AFINITOR at the time of SEGA progression or after the primary analysis, whichever occurred first. After the primary analysis, patients treated with AFINITOR underwent additional follow-up MRI scans to assess tumor status until discontinuation of treatment or completion of 4 years of follow-up after the last patient was randomized. A total of 111 patients (78 patients randomized to AFINITOR and 33

patients randomized to placebo) received at least one dose of AFINITOR. Median duration of AFINITOR treatment and follow-up was 3.9 years (0.2 to 4.9 years).

By four years after the last patient was enrolled, 58% of the 111 patients treated with AFINITOR had a $\geq 50\%$ reduction in SEGA volume relative to baseline, including 27 patients identified at the time of the primary analysis and 37 patients with a SEGA response after the primary analysis. The median time to SEGA response was 5.3 months (2.5 to 33.1 months). Twelve percent of the 111 patients treated with AFINITOR had documented disease progression by the end of the follow-up period and no patient required surgical intervention for SEGA during the study.

Study 2485

Study 2485 (NCT00411619) was an open-label, single-arm trial conducted to evaluate the antitumor activity of AFINITOR 3 mg/m²/orally once daily in patients with SEGA and TSC. Serial radiological evidence of SEGA growth was required for entry. Tumor assessments were performed every 6 months for 60 months after the last patient was enrolled or disease progression, whichever occurred earlier. The major efficacy outcome measure was the reduction in volume of the largest SEGA lesion with 6 months of treatment, as assessed via independent central radiology review. Progression was defined as an increase in volume of the largest SEGA lesion over baseline that was $\geq 25\%$ over the nadir observed on study.

A total of 28 patients received AFINITOR for a median duration of 5.7 years (5 months to 6.9 years); 82% of the 28 patients remained on AFINITOR for at least 5 years. The median age was 11 years (3 to 34 years), 61% male, 86% White.

At the primary analysis, 32% of the 28 patients (95% CI: 16%, 52%) had an objective response at 6 months, defined as at least a 50% decrease in volume of the largest SEGA lesion. At the completion of the study, the median duration of durable response was 12 months (3 months to 6.3 years).

By 60 months after the last patient was enrolled, 11% of the 28 patients had documented disease progression. No patient developed a new SEGA lesion while on AFINITOR. Nine additional patients were identified as having a $\geq 50\%$ volumetric reduction in their largest SEGA lesion between 1 to 4 years after initiating AFINITOR including 3 patients who had surgical resection with subsequent regrowth prior to receiving AFINITOR.

14.6 Tuberos Sclerosis Complex (TSC)-Associated Partial-Onset Seizures

The efficacy of AFINITOR DISPERZ as an adjunctive anti-epileptic drug (AED) was evaluated in a randomized, double-blind, multicenter, placebo-controlled study conducted in patients with TSC-associated partial-onset seizures (EXIST-3, NCT01713946). Patients with a history of inadequate control of partial-onset seizures despite treatment with ≥ 2 sequential AED regimens were randomized to receive placebo or AFINITOR DISPERZ once daily at a dose to achieve a low trough (LT) level (3-7 ng/mL) or a high trough (HT) level (9-15 ng/mL). Randomization was stratified by age group (1 to < 6, 6 to < 12, 12 to < 18, ≥ 18 years). The study consisted of 3 phases: an 8-week Baseline observation phase; an 18-week double-blind, placebo-controlled Core phase (6-week titration period and a 12-week maintenance period), and an Extension phase of ≥ 48 weeks. Patients were required to have a diagnosis of TSC per the modified Gomez criteria, and ≥ 16 partial-onset seizures during the Baseline phase while receiving a stable dose of 1 to 3 concomitant AEDs. The starting doses for AFINITOR DISPERZ in the Core phase ranged from 3 to 6 mg/m² orally once daily, depending on age, in patients not receiving concomitant CYP3A4/P-gp inducers and from 5 to 9 mg/m² orally once daily, depending on age, in patients receiving concomitant CYP3A4/P-gp inducers. During the 6-week titration period, everolimus trough levels were assessed every 2 weeks and up to 3 dose adjustments were allowed to attempt to reach the targeted everolimus trough concentration range.

The major efficacy outcome measure was the percentage reduction in seizure frequency from the Baseline phase, during the maintenance period of the Core phase. Additional efficacy outcome measures included response rate, defined as at least a 50% reduction in seizure frequency from the Baseline phase during the maintenance period of the Core phase, and seizure freedom rate during the maintenance period of the Core phase.

A total of 366 patients were randomized to AFINITOR DISPERZ LT (n = 117), AFINITOR DISPERZ HT (n = 130) or placebo (n = 119). Median age was 10.1 years (2.2 to 56 years); 28% of patients were < 6 years, 31% were 6 to < 12 years, 22% were 12 to < 18 years, and 18% were ≥ 18 years). The majority were White (65%) and male (52%). The most

common major features of TSC were cortical tubers (92%), hypomelanotic macules (84%), and subependymal nodules (83%). While 17% of the patients had SEGA, 42% had renal angiomyolipoma, and 9% had both SEGA and renal angiomyolipoma; no patients were receiving treatment with AFINITOR or AFINITOR DISPERZ for these manifestations of TSC. During the Baseline phase, 65% of patients had complex partial seizures, 52% had secondarily generalized seizures, 19% had simple partial seizures, and 2% had generalized onset seizures. The median seizure frequency per week during the Baseline phase was 9.4 for all patients and 47% of patients were receiving 3 AEDs during the Baseline phase. The efficacy results are summarized in Table 26.

Table 26: Percentage Reduction in Seizure Frequency and Response Rate in TSC-Associated Partial-Onset Seizures in EXIST-3

	AFINITOR DISPERZ		Placebo
	Target of 3-7 ng/mL N = 117	Target of 9-15 ng/mL N = 130	N = 119
Seizures per week			
Median at Baseline (Min, Max)	8.6 (1.4, 192.9)	9.5 (0.3, 218.4)	10.5 (1.3, 231.7)
Median at Core phase ^a (Min, Max)	6.8 (0.0, 193.5)	4.9 (0.0, 133.7)	8.5 (0.0, 217.7)
Percentage reduction from Baseline to Core phase (Maintenance^a)			
Median	29.3	39.6	14.9
95% CI ^b	18.8, 41.9	35.0, 48.7	0.1, 21.7
p-value ^c	0.003	< 0.001	
Response rate			
Responders, n (%)	28.2	40	15.1
95% CI ^d	20.3, 37.3	31.5, 49.0	9.2, 22.8

^aIf patient discontinued before starting the Maintenance period, then the Titration period is used.

^b95% CI of the median based on bootstrap percentiles.

^cp-values were for superiority vs. placebo, and obtained from rank ANCOVA with Baseline seizure frequency as covariate, stratified by age subgroup.

^dExact 95% CI obtained using Clopper-Pearson method.

15 REFERENCES

1. OSHA Hazardous Drugs. *OSHA*. <http://www.osha.gov/SLTC/hazardousdrugs/index.html>.

16 HOW SUPPLIED/STORAGE AND HANDLING

AFINITOR

2.5 mg tablets: White to slightly yellow, elongated tablets with a bevelled edge and engraved with “LCL” on one side and “NVR” on the other; available in:

Blisters of 28 tablets.....NDC 0078-0594-51

Each carton contains 4 blister cards of 7 tablets each

5 mg tablets: White to slightly yellow, elongated tablets with a bevelled edge and engraved with “5” on one side and “NVR” on the other; available in:

Blisters of 28 tablets.....NDC 0078-0566-51

Each carton contains 4 blister cards of 7 tablets each

7.5 mg tablets: White to slightly yellow, elongated tablets with a bevelled edge and engraved with “7P5” on one side and “NVR” on the other; available in:

Blisters of 28 tablets.....NDC 0078-0620-51

Each carton contains 4 blister cards of 7 tablets each

10 mg tablets: White to slightly yellow, elongated tablets with a bevelled edge and engraved with “UHE” on one side and “NVR” on the other; available in:

Blisters of 28 tablets.....NDC 0078-0567-51

Each carton contains 4 blister cards of 7 tablets each

AFINITOR DISPERZ

2 mg tablets for oral suspension: White to slightly yellowish, round, flat tablets with a bevelled edge and engraved with “D2” on one side and “NVR” on the other; available in:

Blisters of 28 tablets.....NDC 0078-0626-51

Each carton contains 4 blister cards of 7 tablets each

3 mg tablets for oral suspension: White to slightly yellowish, round, flat tablets with a bevelled edge and engraved with “D3” on one side and “NVR” on the other; available in:

Blisters of 28 tablets.....NDC 0078-0627-51

Each carton contains 4 blister cards of 7 tablets each

5 mg tablets for oral suspension: White to slightly yellowish, round, flat tablets with a bevelled edge and engraved with “D5” on one side and “NVR” on the other; available in:

Blisters of 28 tablets.....NDC 0078-0628-51

Each carton contains 4 blister cards of 7 tablets each

Store at 25°C (77°F); excursions permitted between 15°C to 30°C (59°F to 86°F). See USP Controlled Room Temperature.

Store in the original container, protect from light and moisture.

Follow special handling and disposal procedures for anticancer pharmaceuticals.¹

17 PATIENT COUNSELING INFORMATION

Advise the patient to read the FDA-approved patient labeling (Patient Information and Instructions for Use).

Non-infectious Pneumonitis

Advise patients of the risk of developing non-infectious pneumonitis and to immediately report any new or worsening respiratory symptoms to their healthcare provider [see *Warnings and Precautions (5.1)*].

Infections

Advise patients that they are more susceptible to infections and that they should immediately report any signs or symptoms of infections to their healthcare provider [see *Warnings and Precautions (5.2)*].

Hypersensitivity Reactions

Advise patients of the risk of clinically significant hypersensitivity reactions and to promptly contact their healthcare provider or seek emergency care for signs of hypersensitivity reaction including rash, itching, hives, difficulty breathing or swallowing, flushing, chest pain, or dizziness [see *Contraindications (4), Warnings and Precautions (5.3)*].

Angioedema with Concomitant Use of ACE Inhibitors

Advise patients to avoid ACE inhibitors and to promptly contact their healthcare provider or seek emergency care for signs or symptoms of angioedema [see *Warnings and Precautions (5.4)*].

Stomatitis

Advise patients of the risk of stomatitis and to use alcohol-free mouthwashes during treatment [see *Warnings and Precautions (5.5)*].

Renal Impairment

Advise patients of the risk of developing kidney failure and the need to monitor their kidney function periodically during treatment [see *Warnings and Precautions (5.6)*].

Risk of Impaired Wound Healing

Advise patients that AFINITOR/AFINITOR DISPERZ may impair wound healing. Advise patients to inform their healthcare provider of any planned surgical procedure [see *Warnings and Precautions (5.7)*].

Geriatric Patients

Inform patients that in a study conducted in patients with breast cancer, the incidence of deaths and adverse reactions leading to permanent discontinuation was higher in patients ≥ 65 years compared to patients < 65 years [see *Warnings and Precautions (5.8)*, *Use in Specific Populations (8.5)*].

Metabolic Disorders

Advise patients of the risk of metabolic disorders and the need to monitor glucose and lipids periodically during therapy [see *Warnings and Precautions (5.9)*].

Myelosuppression

Advise patients of the risk of myelosuppression and the need to monitor CBCs periodically during therapy [see *Warnings and Precautions (5.10)*].

Risk of Infection or Reduced Immune Response with Vaccination

Advise patients to avoid the use of live vaccines and close contact with those who have received live vaccines [see *Warnings and Precautions (5.11)*].

Embryo-Fetal Toxicity

Advise females of reproductive potential of the potential risk to a fetus. Advise females of reproductive potential to use effective contraception during treatment and for 8 weeks after the last dose. Advise patients to inform their healthcare provider of a known or suspected pregnancy. Advise males with female partners of reproductive potential to use effective contraception during treatment and for 4 weeks after the last dose [see *Warnings and Precautions (5.12)*, *Use in Specific Populations (8.1, 8.3)*].

Lactation

Advise women not to breastfeed during treatment with AFINITOR/AFINITOR DISPERZ and for 2 weeks after the last dose [see *Use in Specific Populations (8.2)*].

Infertility

Advise males and females of reproductive potential of the potential risk for impaired fertility [see *Use in Specific Populations (8.3)*].

Distributed by:

Novartis Pharmaceuticals Corporation
East Hanover, New Jersey 07936

T2020-XXX

PATIENT INFORMATION

AFINITOR® (a-fin-it-or)
(everolimus)
tablets

AFINITOR DISPERZ® (a-fin-it-or dis-perz)
(everolimus tablets for oral suspension)

Read this Patient Information leaflet that comes with AFINITOR or AFINITOR DISPERZ before you start taking it and each time you get a refill. There may be new information. This information does not take the place of talking to your healthcare provider about your medical condition or treatment.

What is the most important information I should know about AFINITOR and AFINITOR DISPERZ?

AFINITOR and AFINITOR DISPERZ can cause serious side effects. These serious side effects include:

- 1. You may develop lung or breathing problems.** In some people lung or breathing problems may be severe, and can even lead to death. Tell your healthcare provider right away if you have any of these symptoms:
 - New or worsening cough
 - Shortness of breath
 - Chest pain
 - Difficulty breathing or wheezing
- 2. You may be more likely to develop an infection,** such as pneumonia, or a bacterial, fungal or viral infection. Viral infections may include active hepatitis B in people who have had hepatitis B in the past (reactivation). In some people (including adults and children) these infections may be severe, and can even lead to death. You may need to be treated as soon as possible.

Tell your healthcare provider right away if you have a temperature of 100.5°F or above, chills, or do not feel well.

Symptoms of hepatitis B or infection may include the following:

- Fever
 - Chills
 - Skin rash
 - Joint pain and inflammation
 - Tiredness
 - Loss of appetite
 - Nausea
 - Pale stools or dark urine
 - Yellowing of the skin
 - Pain in the upper right side of the stomach
- 3. Severe allergic reactions.** Severe allergic reactions can happen in people who take AFINITOR or AFINITOR DISPERZ. Call your healthcare provider or get medical help right away if you get signs and symptoms of a severe allergic reaction including: rash, itching, hives, flushing, trouble breathing or swallowing, chest pain or dizziness.
 - 4. Possible increased risk for a type of allergic reaction called angioedema,** in people who take an Angiotensin-Converting Enzyme (ACE) inhibitor medicine during treatment with AFINITOR or AFINITOR DISPERZ. Talk with your healthcare provider before taking AFINITOR or AFINITOR DISPERZ if you are not sure if you take an ACE inhibitor medicine. Get medical help right away if you have trouble breathing or develop swelling of your tongue, mouth, or throat during treatment with AFINITOR or AFINITOR DISPERZ.
 - 5. You may develop kidney failure.** In some people this may be severe and can even lead to death. Your healthcare provider should do tests to check your kidney function before and during your treatment with AFINITOR or AFINITOR DISPERZ.

If you have any of the serious side effects listed above, you may need to stop taking AFINITOR or AFINITOR DISPERZ for a while or use a lower dose. Follow your healthcare provider's instructions.

What is AFINITOR?

AFINITOR is a prescription medicine used to treat:

- advanced hormone receptor-positive, HER2-negative breast cancer, along with the medicine exemestane, in postmenopausal women who have already received certain other medicines for their cancer.
- adults with a type of pancreatic cancer known as pancreatic neuroendocrine tumor (PNET), that has progressed and cannot be treated with surgery.

- adults with a type of cancer known as neuroendocrine tumor (NET) of the stomach and intestine (gastrointestinal), or lung that has progressed and cannot be treated with surgery.
AFINITOR is not for use in people with carcinoid tumors that actively produce hormones.
- adults with advanced kidney cancer (renal cell carcinoma or RCC) when certain other medicines have not worked.
- people with the following types of tumors that are seen with a genetic condition called tuberous sclerosis complex (TSC):
 - adults with a kidney tumor called angiomyolipoma, when their kidney tumor does not require surgery right away.
 - adults and children 1 year of age and older with a brain tumor called subependymal giant cell astrocytoma (SEGA) when the tumor cannot be removed completely by surgery.

What is AFINITOR DISPERZ?

AFINITOR DISPERZ is a prescription medicine used to treat:

- adults and children 1 year of age and older with a genetic condition called tuberous sclerosis complex (TSC) who have a brain tumor called subependymal giant cell astrocytoma (SEGA) when the tumor cannot be removed completely by surgery.
- adults and children 2 years of age and older with a genetic condition called tuberous sclerosis complex (TSC) who have certain types of seizures (epilepsy), as an added treatment to other antiepileptic medicines.

It is not known if AFINITOR and AFINITOR DISPERZ are safe and effective in children to treat:

- hormone receptor-positive, HER-2 negative breast cancer
- a type of cancer called neuroendocrine tumors (NET)
- kidney cancer (renal cell carcinoma)
- a kidney tumor called angiomyolipoma, that can happen in children with a genetic condition called tuberous sclerosis complex (TSC).

Who should not take AFINITOR or AFINITOR DISPERZ?

Do not take AFINITOR or AFINITOR DISPERZ if you have had a severe allergic reaction to everolimus.

Talk to your healthcare provider before taking this medicine if you are allergic to:

- sirolimus (Rapamune[®])
- temsirolimus (Torisel[®])

Ask your healthcare provider if you do not know.

What should I tell my healthcare provider before taking AFINITOR or AFINITOR DISPERZ?

Before taking AFINITOR or AFINITOR DISPERZ, tell your healthcare provider about all of your medical conditions, including if you:

- Have or have had kidney problems
- Have or have had liver problems
- Have diabetes or high blood sugar
- Have high blood cholesterol levels
- Have any infections
- Previously had hepatitis B
- Are scheduled to receive any vaccinations. You should not receive a “live vaccine” or be around people who have recently received a “live vaccine” during your treatment with AFINITOR or AFINITOR DISPERZ. If you are not sure about the type of immunization or vaccine, ask your healthcare provider. For children with TSC and SEGA or certain types of seizures, work with your healthcare provider to complete the recommended childhood series of vaccines before your child starts treatment with AFINITOR or AFINITOR DISPERZ.
- Are pregnant, can become pregnant, or have a partner who can become pregnant. AFINITOR or AFINITOR DISPERZ can cause harm to your unborn baby. If you are a female who is able to become pregnant you should use effective birth control during treatment and for 8 weeks after your last dose of AFINITOR or AFINITOR DISPERZ. If you are a male with

a female partner, you should use effective birth control during treatment and for 4 weeks after your last dose of AFINITOR or AFINITOR DISPERZ. Talk to your healthcare provider about birth control methods that may be right for you during this time. If you become pregnant or think you are pregnant, tell your healthcare provider right away.

- Are breastfeeding or plan to breastfeed. It is not known if AFINITOR or AFINITOR DISPERZ passes into your breast milk. Do not breastfeed during treatment and for 2 weeks after your last dose of AFINITOR or AFINITOR DISPERZ.
- Are planning to have surgery or if you have had a recent surgery. You should stop taking AFINITOR or AFINITOR DISPERZ at least 1 week before planned surgery. See **“What are the possible side effects of AFINITOR and AFINITOR DISPERZ?”**

Tell your healthcare provider about all of the medicines you take, including prescription and over-the-counter medicines, vitamins, and herbal supplements.

AFINITOR or AFINITOR DISPERZ may affect the way other medicines work, and other medicines can affect how AFINITOR or AFINITOR DISPERZ work. Taking AFINITOR or AFINITOR DISPERZ with other medicines can cause serious side effects. Know the medicines you take. Keep a list of them and show it to your healthcare provider and pharmacist when you get a new medicine. Especially tell your healthcare provider if you take:

- St. John’s Wort (*Hypericum perforatum*)
- Medicine for:
 - Fungal infections
 - Bacterial infections
 - Tuberculosis
 - Seizures
 - HIV-AIDS
 - Heart conditions or high blood pressure
- Medicines that weaken your immune system (your body’s ability to fight infections and other problems)

Ask your healthcare provider or pharmacist if you are not sure if your medicine is one of those taken for the conditions listed above. If you are taking any medicines for the conditions listed above, your healthcare provider might need to prescribe a different medicine or your dose of AFINITOR or AFINITOR DISPERZ may need to be changed. You should also tell your healthcare provider before you start taking any new medicine.

How should I take AFINITOR or AFINITOR DISPERZ?

- Your healthcare provider will prescribe the dose of AFINITOR or AFINITOR DISPERZ that is right for you.
- Take AFINITOR or AFINITOR DISPERZ exactly as your healthcare provider tells you to.
- When you start treatment with AFINITOR, your healthcare provider may also prescribe a mouthwash to reduce the likelihood of getting mouth ulcers or sores and to reduce their severity. Follow your healthcare provider’s instructions on how to use this prescription mouthwash.
- Your healthcare provider may change your dose of AFINITOR or AFINITOR DISPERZ or tell you to temporarily interrupt dosing, if needed.
- **Take only AFINITOR or AFINITOR DISPERZ. Do not mix AFINITOR and AFINITOR DISPERZ together.**
- Use scissors to open the blister pack.

AFINITOR:

- Swallow AFINITOR tablets whole with a glass of water. Do not take any tablet that is broken or crushed.

AFINITOR DISPERZ:

- If your healthcare provider prescribes AFINITOR DISPERZ for you, see the “Instructions for Use” that come with your medicine for instructions on how to prepare and take your dose.
- Each dose of AFINITOR DISPERZ must be prepared as a suspension before it is given.
- AFINITOR DISPERZ can cause harm to an unborn baby. When possible, the suspension should be prepared by an adult who is not pregnant or planning to become pregnant.

- Wear gloves to avoid possible contact with everolimus when preparing suspensions of AFINITOR DISPERZ for another person.
- Take AFINITOR or AFINITOR DISPERZ 1 time each day at about the same time.
- Take AFINITOR or AFINITOR DISPERZ the same way each time, either with food or without food.
- If you take too much AFINITOR or AFINITOR DISPERZ, contact your healthcare provider or go to the nearest hospital emergency room right away. Take the pack of AFINITOR or AFINITOR DISPERZ with you.
- If you miss a dose of AFINITOR or AFINITOR DISPERZ, you may take it if it is **less than 6 hours** after the time you normally take it. If it is **more than 6 hours** after you normally take your AFINITOR or AFINITOR DISPERZ, skip the dose for that day. The next day, take AFINITOR or AFINITOR DISPERZ at your usual time. Do not take 2 doses to make up for a missed dose. If you are not sure about what to do, call your healthcare provider.
- You should have blood tests before you start AFINITOR or AFINITOR DISPERZ and as needed during your treatment. These will include tests to check your blood cell count, kidney and liver function, cholesterol, and blood sugar levels.
- If you take AFINITOR or AFINITOR DISPERZ to treat SEGA or AFINITOR DISPERZ to treat certain types of seizures with TSC, you will also need to have blood tests regularly to measure how much medicine is in your blood. This will help your healthcare provider decide how much AFINITOR or AFINITOR DISPERZ you need to take.

What should I avoid while taking AFINITOR or AFINITOR DISPERZ?

You should not drink grapefruit juice or eat grapefruit during your treatment with AFINITOR or AFINITOR DISPERZ. It may make the amount of AFINITOR or AFINITOR DISPERZ in your blood increase to a harmful level.

What are the possible side effects of AFINITOR or AFINITOR DISPERZ?

AFINITOR and AFINITOR DISPERZ can cause serious side effects.

- **See “What is the most important information I should know about AFINITOR and AFINITOR DISPERZ?” for more information.**
- **Risk of wound healing problems.** Wounds may not heal properly during AFINITOR and AFINITOR DISPERZ treatment. Tell your healthcare provider if you plan to have any surgery before starting or during treatment with AFINITOR and AFINITOR DISPERZ.
 - You should stop taking AFINITOR and AFINITOR DISPERZ at least 1 week before planned surgery.
 - Your healthcare provider should tell you when you may start taking AFINITOR and AFINITOR DISPERZ again after surgery.
- **Increased blood sugar and fat (cholesterol and triglyceride) levels in the blood.** Your healthcare provider should do blood tests to check your fasting blood sugar, cholesterol, and triglyceride levels in the blood before you start and during treatment with AFINITOR or AFINITOR DISPERZ.
- **Decreased blood cell counts.** AFINITOR and AFINITOR DISPERZ can cause you to have decreased red blood cells, white blood cells, and platelets. Your healthcare provider should do blood tests to check your blood cell counts before you start and during treatment with AFINITOR or AFINITOR DISPERZ.

The most common side effects of AFINITOR in people with advanced hormone receptor-positive, HER2-negative breast cancer, advanced neuroendocrine tumors of the pancreas, stomach and intestine (gastrointestinal) or lung, and advanced kidney cancer include:

- **Mouth ulcers.** AFINITOR can cause mouth ulcers and sores. When you start treatment with AFINITOR, your healthcare provider may tell you to also start a prescription mouthwash to reduce the likelihood of getting mouth ulcers or sores and to reduce their severity. Follow your healthcare provider’s instructions on how to use this prescription mouthwash. If you develop pain, discomfort, or open sores in your mouth, tell your healthcare provider. Your healthcare provider may tell you to re-start this mouthwash or to use a special mouthwash or mouth gel that does not contain alcohol, peroxide, iodine, or thyme.

- Infections
- Rash
- Feeling weak or tired
- Diarrhea
- Swelling of arms, hands, feet, ankles, face, or other parts of the body
- Stomach-area (abdominal) pain
- Nausea
- Fever
- Cough
- Headache
- Decreased appetite

The most common side effects of AFINITOR and AFINITOR DISPERZ in people who have SEGA, renal angiomyolipoma, or certain types of seizures with TSC include:

- Mouth ulcers. AFINITOR and AFINITOR DISPERZ can cause mouth ulcers and sores. When you start treatment with AFINITOR or AFINITOR DISPERZ, your healthcare provider may tell you to also start a prescription mouthwash to reduce the likelihood of getting mouth ulcers or sores and to reduce their severity. Follow your healthcare provider's instructions on how to use this prescription mouthwash. If you develop pain, discomfort, or open sores in your mouth, tell your healthcare provider. Your healthcare provider may tell you to re-start this mouthwash or to use a special mouthwash or mouth gel that does not contain alcohol, peroxide, iodine, or thyme.
- Respiratory tract infections.

Other side effects that may occur with AFINITOR and AFINITOR DISPERZ:

- Absence of menstrual periods (menstruation). You may miss 1 or more menstrual periods. Tell your healthcare provider if this happens.
- AFINITOR and AFINITOR DISPERZ may affect fertility in females and may affect your ability to become pregnant. Talk to your healthcare provider if this is a concern for you.
- AFINITOR and AFINITOR DISPERZ may affect fertility in males and may affect your ability to father a child. Talk to your healthcare provider if this is a concern for you.

Tell your healthcare provider if you have any side effect that bothers you or does not go away.

These are not all the possible side effects of AFINITOR and AFINITOR DISPERZ. For more information, ask your healthcare provider or pharmacist.

Call your doctor for medical advice about side effects. You may report side effects to FDA at 1-800-FDA-1088.

How should I store AFINITOR or AFINITOR DISPERZ?

- Store AFINITOR or AFINITOR DISPERZ at room temperature, between 68°F to 77°F (20°C to 25°C).
- Keep AFINITOR or AFINITOR DISPERZ in the pack it comes in.
- Open the blister pack just before taking AFINITOR or AFINITOR DISPERZ.
- Keep AFINITOR or AFINITOR DISPERZ dry and away from light.
- Do not use AFINITOR or AFINITOR DISPERZ that is out of date or no longer needed.

Keep AFINITOR or AFINITOR DISPERZ and all medicines out of the reach of children.

General information about AFINITOR and AFINITOR DISPERZ

Medicines are sometimes prescribed for purposes other than those listed in a Patient Information leaflet. Do not use AFINITOR or AFINITOR DISPERZ for a condition for which it was not prescribed. Do not give AFINITOR or AFINITOR DISPERZ to other people, even if they have the same problem you have. It may harm them.

This leaflet summarizes the most important information about AFINITOR and AFINITOR DISPERZ. If you would like more information, talk with your healthcare provider. You can ask your healthcare provider or pharmacist for information written for healthcare professionals.

For more information call 1-888-423-4648 or go to www.AFINITOR.com.

What are the ingredients in AFINITOR?

Active ingredient: everolimus.

Inactive ingredients: anhydrous lactose, butylated hydroxytoluene, crospovidone, hypromellose, lactose monohydrate, and magnesium stearate.

What are the ingredients in AFINITOR DISPERZ?

Active ingredient: everolimus.

Inactive ingredients: butylated hydroxytoluene, colloidal silicon dioxide, crospovidone, hypromellose, lactose monohydrate, magnesium stearate, mannitol, and microcrystalline cellulose.

Distributed by:

Novartis Pharmaceuticals Corporation

East Hanover, New Jersey 07936

The brands listed are the trademarks or register marks of their respective owners and are not trademarks or register marks of Novartis.

© Novartis

T2020-XXX

This Patient Information has been approved by the U.S. Food and Drug Administration.

Revised: 2/2020

PRODUCT MONOGRAPH
INCLUDING PATIENT MEDICATION INFORMATION



(bictegravir/emtricitabine/tenofovir alafenamide) tablets
Oral

50 mg bictegravir*
200 mg emtricitabine
25 mg tenofovir alafenamide**

*as 52.5 mg bictegravir sodium
**as 28.0 mg tenofovir alafenamide hemifumarate

Antiretroviral Agent

Gilead Sciences Canada, Inc.
Mississauga, ON L5N 2W3

www.gilead.ca

Submission Control No: 226658

Date of Initial Approval:
July 10, 2018

Date of Revision:
February 28, 2020

RECENT MAJOR LABEL CHANGES

Indications (1)	10/2019
Indications, Pediatrics (1.1)	10/2019
Dosage and Administration, Recommended Dose and Dosage Adjustment (4.2)	10/2019
Dosage and Administration, Administration (4.3)	10/2019
Warnings and Precautions (7), Endocrine and Metabolism	10/2019
Warnings and Precautions (7), Immune Reconstitution Syndrome	05/2019
Warnings and Precautions, Special Populations, Pregnant Women (7.1.1)	10/2019
Warnings and Precautions, Special Populations, Pediatrics (7.1.3)	10/2019

TABLE OF CONTENTS

PART I: HEALTH PROFESSIONAL INFORMATION	4
1 INDICATIONS	4
1.1 Pediatrics.....	4
1.2 Geriatrics.....	4
2 CONTRAINDICATIONS	4
3 SERIOUS WARNINGS AND PRECAUTIONS BOX	5
4 DOSAGE AND ADMINISTRATION	5
4.1 Dosing Considerations.....	5
4.2 Recommended Dose and Dosage Adjustment.....	5
4.3 Administration.....	6
4.4 Missed Dose.....	6
5 OVERDOSAGE	6
6 DOSAGE FORMS, STRENGTHS, COMPOSITION AND PACKAGING	7
7 WARNINGS AND PRECAUTIONS	7
7.1 Special Populations.....	9
7.1.1 Pregnant Women.....	9
7.1.2 Breast-feeding.....	10
7.1.3 Pediatrics.....	10
7.1.4 Geriatrics.....	10
7.1.5 Patients Co-infected with HIV and HBV.....	10
8 ADVERSE REACTIONS	10
8.1 Adverse Reaction Overview.....	10
8.2 Clinical Trial Adverse Reactions.....	11
8.3 Less Common Clinical Trial Adverse Reactions.....	12
8.4 Abnormal Laboratory Findings: Hematologic, Clinical Chemistry and Other Quantitative Data.....	13
8.5 Post-Market Adverse Reactions.....	15
9 DRUG INTERACTIONS	15

9.1	Overview.....	16
9.2	Drug-Drug Interactions.....	17
9.3	Drug Interaction Studies	19
9.4	Drug-Food Interactions	23
9.5	Drug-Herb Interactions.....	23
9.6	Drug-Laboratory Test Interactions.....	23
9.7	Drug-Lifestyle Interactions	23
10	ACTION AND CLINICAL PHARMACOLOGY.....	23
10.1	Mechanism of Action	23
10.2	Pharmacodynamics.....	24
10.3	Pharmacokinetics.....	25
11	STORAGE, STABILITY AND DISPOSAL.....	28
12	SPECIAL HANDLING INSTRUCTIONS.....	28
13	PHARMACEUTICAL INFORMATION.....	29
14	CLINICAL TRIALS.....	31
14.1	Trial Design and Study Demographics	31
14.2	Study Results	35
15	MICROBIOLOGY.....	41
16	NON-CLINICAL TOXICOLOGY.....	43
17	SUPPORTING PRODUCT MONOGRAPHS	44
	PATIENT MEDICATION INFORMATION	45

PART I: HEALTH PROFESSIONAL INFORMATION

1 INDICATIONS

BIKTARVY (bictegravir/emtricitabine/tenofovir alafenamide) is indicated as a complete regimen for the treatment of human immunodeficiency virus-1 (HIV-1) infection in adults and pediatric patients weighing ≥ 25 kg with no known substitution associated with resistance to the individual components of BIKTARVY.

1.1 Pediatrics

Pediatrics (weighing ≥ 25 kg): The safety and efficacy in pediatric patients weighing ≥ 25 kg are based on data from an open-label clinical study (see **ADVERSE REACTIONS** and **CLINICAL TRIALS**).

Safety and efficacy of BIKTARVY in children weighing < 25 kg have not been established.

1.2 Geriatrics

Geriatrics (≥ 65 years of age): Clinical studies of BIKTARVY did not include sufficient numbers of patients aged 65 years and over to determine whether they respond differently from patients less than 65 years of age.

2 CONTRAINDICATIONS

BIKTARVY is contraindicated in patients who are hypersensitive to bictegravir, emtricitabine (FTC), tenofovir alafenamide (TAF) or to any ingredient in the formulation or component of the container. For a complete listing, see **DOSAGE FORMS, STRENGTHS, COMPOSITION AND PACKAGING**.

Coadministration of BIKTARVY is contraindicated with:

- dofetilide* due to the potential for increased dofetilide plasma concentrations and associated serious and/or life-threatening events (see **DRUG INTERACTIONS**).
- rifampin due to decreased bictegravir plasma concentrations, which may result in the loss of therapeutic effect and development of resistance to BIKTARVY (see **DRUG INTERACTIONS**).
- St. John's wort due to the effect of St. John's wort on the bictegravir component of BIKTARVY. This may result in loss of therapeutic effect and development of resistance (see **DRUG INTERACTIONS**).

*Product not marketed in Canada

3 SERIOUS WARNINGS AND PRECAUTIONS BOX

Serious Warnings and Precautions

Post-treatment Exacerbation of Hepatitis B

Severe acute exacerbations of hepatitis B have been reported in patients who are coinfecting with HIV-1 and HBV and have discontinued products containing emtricitabine (FTC) and/or tenofovir disoproxil fumarate (TDF), and may occur with discontinuation of BIKTARVY. Hepatic function should be monitored closely with both clinical and laboratory follow-up for at least several months in patients who are coinfecting with HIV-1 and HBV and discontinue BIKTARVY. If appropriate, anti-hepatitis B therapy may be warranted (see **WARNINGS AND PRECAUTIONS, Special Populations**).

4 DOSAGE AND ADMINISTRATION

4.1 Dosing Considerations

BIKTARVY is a three-drug fixed dose combination product containing 50 mg of bictegravir, 200 mg of emtricitabine, and 25 mg of tenofovir alafenamide.

Testing

Prior to or when initiating BIKTARVY, test for hepatitis B virus infection.

Prior to or when initiating BIKTARVY, and during treatment with BIKTARVY, assess serum creatinine, estimated creatinine clearance, urine glucose, and urine protein in all patients as clinically appropriate. In patients with chronic kidney disease, also assess serum phosphorus.

4.2 Recommended Dose and Dosage Adjustment

Adults and Pediatric Patients weighing ≥ 25 kg

The recommended dose of BIKTARVY is one tablet taken orally once daily with or without food.

Pediatrics (weighing < 25 kg)

BIKTARVY is not indicated for use in pediatric patients weighing < 25 kg

Geriatrics (≥ 65 years of age)

Clinical trials of BIKTARVY did not include sufficient numbers of patients aged 65 and over to determine whether they respond differently from younger patients (see **ACTION AND CLINICAL PHARMACOLOGY: Pharmacokinetics, Special Populations and Conditions**).

Renal Impairment

BIKTARVY is not recommended in patients with estimated creatinine clearance below 30 mL per minute.

No dose adjustment of BIKTARVY is required in patients with estimated creatinine clearance greater than or equal to 30 mL per minute.

Hepatic Impairment

BIKTARVY is not recommended in patients with severe hepatic impairment (Child-Pugh Class C) because it has not been studied in these patients. No dose adjustment of BIKTARVY is required in patients with mild (Child-Pugh Class A) or moderate (Child-Pugh Class B) hepatic impairment (see **ACTION AND CLINICAL PHARMACOLOGY: Pharmacokinetics, Special Populations and Conditions**).

4.3 Administration

The recommended dose of BIKTARVY is one tablet taken orally once daily with or without food in adults and pediatric patients weighing ≥ 25 kg.

4.4 Missed Dose

If a patient misses a dose of BIKTARVY within 18 hours of the time it is usually taken, the patient should take BIKTARVY as soon as possible, and then take the next dose of BIKTARVY at the regularly scheduled time. If a patient misses a dose of BIKTARVY by more than 18 hours, the patient should not take the missed dose and simply resume the usual dosing schedule.

5 OVERDOSAGE

No data are available on overdose of BIKTARVY in patients. If overdose occurs, the patient must be monitored for evidence of toxicity. Treatment of overdose with BIKTARVY consists of general supportive measures including monitoring of vital signs as well as observation of the clinical status of the patient.

There is no specific antidote for overdose with BIKTARVY. As bictegravir is highly bound to plasma proteins, it is unlikely that it will be significantly removed by hemodialysis or peritoneal dialysis. Emtricitabine can be removed by hemodialysis, which removes approximately 30% of the emtricitabine dose over a 3 hour dialysis period starting within 1.5 hours of emtricitabine dosing. It is not known whether emtricitabine can be removed by peritoneal dialysis. Tenofovir is efficiently removed by hemodialysis with an extraction coefficient of approximately 54%.

For management of a suspected drug overdose, contact your regional poison control centre.

6 DOSAGE FORMS, STRENGTHS, COMPOSITION AND PACKAGING

Table 1 Dosage Forms, Strengths, Composition and Packaging

Route of Administration	Dosage Form / Strength/Composition	Non-medicinal Ingredients
Oral	<p>Each tablet contains 50 mg of bictegravir (equivalent to 52.5 mg of bictegravir sodium), 200 mg of emtricitabine, and 25 mg of tenofovir alafenamide (equivalent to 28.0 mg of tenofovir alafenamide hemifumarate).</p> <p>The tablets are purplish brown, capsule-shaped, film-coated, and debossed with “GSI” on one side and “9883” on the other side.</p> <p>BIKTARVY tablets are packaged in white, high density polyethylene (HDPE) bottles and enclosed with a polypropylene continuous-thread child-resistant cap, lined with an induction activated aluminum foil liner. Each bottle contains 30 tablets, silica gel desiccant, and polyester coil.</p>	<p>Tablet Core: Microcrystalline Cellulose, Croscarmellose Sodium, Magnesium Stearate Film-Coating: Iron Oxide Black, Iron Oxide Red, Polyethylene Glycol, Polyvinyl Alcohol, Talc, Titanium Dioxide</p>

7 WARNINGS AND PRECAUTIONS

Please see the **SERIOUS WARNINGS AND PRECAUTIONS BOX** at the beginning of Part I: Health Professional Information.

General

BIKTARVY should not be coadministered with any other antiretroviral products including products containing bictegravir, emtricitabine, or tenofovir alafenamide (ATRIPLA[®], COMPLERA[®], DESCOVY[®], EMTRIVA[®], GENVOYA[®], ODEFSEY[®], Symtuza[™], STRIBILD[®], TRUVADA[®], TYBOST[®], VEMLIDY[®]); or with products containing lamivudine or tenofovir disoproxil fumarate (3TC[®], ATRIPLA, Combivir[®], COMPLERA, Kivexa[®], STRIBILD, Triumeq[®], Trizivir[®], TRUVADA, VIREAD[®]). BIKTARVY should not be administered with adefovir dipivoxil (HEPSERA[®]).

The safety and efficacy of BIKTARVY have not been established in patients who have failed treatment with an antiretroviral therapy regimen and are currently not virologically suppressed.

Driving and Operating Machinery

No studies on the effects of BIKTARVY on the ability to drive and use machines have been performed.

Endocrine and Metabolism

Serum Lipids and Blood Glucose

Serum lipid and blood glucose levels may increase during antiretroviral therapy (ART). Disease control and life style changes may also be contributing factors. Consideration should be given to the measurement of serum lipids and blood glucose. Lipid disorders and blood glucose elevations should be managed as clinically appropriate.

Hepatic/Biliary/Pancreatic

Lactic acidosis and severe hepatomegaly with steatosis

Lactic acidosis and severe hepatomegaly with steatosis, including fatal cases, have been reported with the use of antiretroviral nucleoside analogs, including emtricitabine, a component of BIKTARVY, and tenofovir disoproxil fumarate, another prodrug of tenofovir, alone or in combination with other antiretrovirals. Treatment with BIKTARVY should be suspended in any patient who develops clinical or laboratory findings suggestive of lactic acidosis or pronounced hepatotoxicity (which may include hepatomegaly and steatosis even in the absence of marked transaminase elevations).

Hepatic Impairment

Patients with chronic hepatitis B or C and treated with antiretroviral therapy are at increased risk for severe hepatic adverse events (see **WARNINGS AND PRECAUTIONS, Special Populations**).

Immune Reconstitution Inflammatory Syndrome

Immune reconstitution inflammatory syndrome has been reported in patients treated with combination antiretroviral therapy, including emtricitabine, a component of BIKTARVY. During the initial phase of combination antiretroviral treatment, patients whose immune system responds may develop an inflammatory response to indolent or residual opportunistic infections [such as *Mycobacterium avium* infection, cytomegalovirus, *Pneumocystis jirovecii* pneumonia (PCP), or tuberculosis], which may necessitate further evaluation and treatment.

Autoimmune disorders (such as Graves' disease, polymyositis, Guillain-Barré syndrome, and autoimmune hepatitis) have also been reported to occur in the setting of immune reconstitution; however, the reported time to onset is more variable, and can occur many months after initiation of treatment.

Renal

Renal impairment

Renal impairment, including cases of acute renal failure and Fanconi syndrome (renal tubular injury with severe hypophosphatemia), has been reported with the use of tenofovir prodrugs in both animal toxicology studies and human trials. In clinical trials with BIKTARVY, there have been no cases of Fanconi syndrome or proximal renal tubulopathy (PRT).

Patients taking tenofovir prodrugs who have impaired renal function and those taking nephrotoxic agents including non-steroidal anti-inflammatory drugs are at increased risk of

developing renal-related adverse reactions.

7.1 Special Populations

7.1.1 Pregnant Women

There are no adequate and well controlled studies of BIKTARVY or its components in pregnant women. Dolutegravir, another integrase inhibitor, has been associated with neural tube defects (NTDs). There are insufficient human data on the use of BIKTARVY during pregnancy to inform a drug-associated risk of birth defects and miscarriage. BIKTARVY should not be used during pregnancy unless the potential benefits outweigh the potential risks to the foetus.

Bictegravir

Data from an observational study in Botswana showed that dolutegravir, another integrase inhibitor, was associated with increased risk of neural tube defects when administered at the time of conception and in early pregnancy. Data available to date from other sources including the Antiretroviral Pregnancy Registry (APR), clinical trials, and postmarketing data are insufficient to address this risk with bictegravir.

Embryo-fetal development toxicity studies of bictegravir conducted in pregnant rats and rabbits revealed no evidence of adverse developmental effects at maternal exposures that were approximately 36 and 0.6 times, respectively, the human exposure at the recommended human dose. In rabbits, abortions and decreased fetal body weight were noted at maternally toxic exposures that were approximately 1.4 times the human exposure at the recommended human dose.

Emtricitabine

Reproductive studies were conducted in rats, mice, and rabbits. Animal studies (performed at 60- to 120-fold human exposure) did not indicate harmful effects of emtricitabine with respect to fertility, pregnancy, fetal parameters, parturition or postnatal development.

Tenofovir Alafenamide

Embryonic fetal development studies performed in rats and rabbits revealed no evidence of impaired fertility or harm to the fetus. The embryo-fetal NOAELs in rats and rabbits occurred at tenofovir alafenamide exposures approximately 2 and 78 times higher than, respectively, the exposure in humans at the recommended daily dose of BIKTARVY. Tenofovir alafenamide is rapidly converted to tenofovir; the observed tenofovir exposure in rats and rabbits were 55 and 86 times higher, respectively, than human tenofovir exposures at the recommended human dose.

Antiretroviral Pregnancy Registry: To monitor maternal-fetal outcomes of pregnant women exposed to ART (antiretroviral therapy), including BIKTARVY, an Antiretroviral Pregnancy Registry has been established. Healthcare providers are encouraged to register patients:

<http://www.apregistry.com>

Telephone: (800) 258-4263

Fax: (800) 800-1052

7.1.2 Breast-feeding

In animal studies, bictegravir was detected in the plasma of nursing rat pups likely due to the presence of bictegravir in milk, without effects on nursing pups. In animal studies, it has been shown that tenofovir is secreted into milk. It is not known whether bictegravir or TAF are secreted in human milk. In humans, samples of breast milk obtained from five HIV-1 infected mothers given TRUVADA (emtricitabine (FTC)/tenofovir disoproxil fumarate (TDF)) show that FTC is secreted in human milk at estimated neonatal concentrations 3 to 12 times higher than the FTC IC₅₀ but 3 to 12 times lower than the C_{min} achieved from oral administration of FTC. Breastfeeding infants whose mothers are being treated with FTC may be at risk for developing viral resistance to FTC. Other FTC-associated risks in infants breastfed by mothers being treated with FTC are unknown.

7.1.3 Pediatrics

Safety and effectiveness of BIKTARVY in pediatric patients weighing < 25 kg have not been established.

7.1.4 Geriatrics

Clinical studies of BIKTARVY did not include sufficient numbers of patients aged 65 and over to determine whether they respond differently from younger patients.

7.1.5 Patients Co-infected with HIV and HBV

Prior to or when initiating BIKTARVY, test for hepatitis B virus infection [see **DOSAGE AND ADMINISTRATION (4.1)**].

Severe acute exacerbations of hepatitis B have been reported in patients who are coinfecting with HIV-1 and HBV and have discontinued products containing FTC and/or TDF, and may occur with discontinuation of BIKTARVY. Therefore, patients co-infected with HIV-1 and HBV who discontinue BIKTARVY should be closely monitored with both clinical and laboratory follow-up for at least several months after stopping treatment. If appropriate, anti-hepatitis B therapy may be warranted, especially in HBV co-infected patients with advanced liver disease or cirrhosis since post-treatment exacerbation of hepatitis may lead to hepatic decompensation.

8 ADVERSE REACTIONS

8.1 Adverse Reaction Overview

The following adverse drug reactions are discussed in other sections of the labeling:

- Severe Acute Exacerbations of Hepatitis B [See **SERIOUS WARNINGS AND PRECAUTIONS BOX**]
- Immune Reconstitution Inflammatory Syndrome [See **WARNINGS AND PRECAUTIONS**].
- Lactic Acidosis/Severe Hepatomegaly with Steatosis [See **WARNINGS AND PRECAUTIONS**]

8.2 Clinical Trial Adverse Reactions

Because clinical trials are conducted under very specific conditions, the adverse reaction rates observed in the clinical trials may not reflect the rates observed in practice and should not be compared to the rates in the clinical trials of another drug. Adverse reaction information from clinical trials is useful for identifying drug-related adverse events and for approximating rates.

Clinical Trials in Treatment-Naïve Adults

The primary safety assessment of BIKTARVY was based on Week 96 pooled data from 1274 patients in two randomized, double-blind, active-controlled trials, Study 1489 and Study 1490, in antiretroviral treatment-naïve HIV-1 infected adult patients. A total of 634 patients received one tablet of BIKTARVY once daily [See **CLINICAL TRIALS**].

The most common adverse reactions (all Grades) reported in at least 5% of patients in the BIKTARVY group in Study 1489 were diarrhea, nausea, and headache. No adverse reactions were reported in at least 5% in the BIKTARVY group in Study 1490. The proportion of patients who discontinued treatment with BIKTARVY, abacavir [ABC]/dolutegravir [DTG]/lamivudine [3TC], or DTG + emtricitabine (FTC)/tenofovir alafenamide (TAF), due to adverse events, regardless of severity, was 0.9%, 1.6%, and 1.5%, respectively. Table 2 and Table 3 display the frequency of adverse reactions (all Grades) greater than or equal to 2% in the BIKTARVY group in Study 1489 and Study 1490, respectively.

Table 2 Adverse Reactions^a (All Grades) Reported in ≥ 2% of HIV-1 Infected Treatment-Naïve Adults Receiving BIKTARVY in Study 1489 (Week 48 and 96 analysis)

Adverse Reactions	Week 48		Week 96	
	BIKTARVY N=314 (%)	ABC/DTG/3TC N=315 (%)	BIKTARVY N=314 (%)	ABC/DTG/3TC N=315 (%)
GASTROINTESTINAL DISORDERS				
Diarrhea	6	4	6	4
Nausea	5	17	6	17
GENERAL DISORDERS AND ADMINISTRATION SITE CONDITIONS				
Fatigue	3	3	3	3
NERVOUS SYSTEM DISORDERS				
Headache	5	5	5	5
Dizziness	2	3	2	3
PSYCHIATRIC DISORDERS				
Insomnia	2	3	2	3
Abnormal dreams	3	3	3	3

a. Frequencies of adverse reactions are based on all adverse events attributed to study drugs by the investigator. No adverse reactions of Grade 2 or higher occurred in ≥1% of patients treated with BIKTARVY in Study 1489.

Table 3 Adverse Reactions^a (All Grades) Reported in ≥ 2% of HIV-1 Infected Treatment-Naïve Adults Receiving BIKTARVY in Study 1490 (Week 48 and 96 analysis)

Adverse Reactions	Week 48		Week 96	
	BIKTARVY N=320 (%)	DTG + FTC/TAF N=325 (%)	BIKTARVY N=320 (%)	DTG + FTC/TAF N=325 (%)
GASTROINTESTINAL DISORDERS				
Diarrhea	3	3	3	3
Nausea	3	5	3	5
GENERAL DISORDERS AND ADMINISTRATION SITE CONDITIONS				
Fatigue	2	2	2	2
NERVOUS SYSTEM DISORDERS				
Headache	4	3	4	3
Dizziness	2	1	2	1
PSYCHIATRIC DISORDERS				
Insomnia	2	<1	2	<1

- a. Frequencies of adverse reactions are based on all adverse events attributed to study drugs by the investigator. No adverse reactions of Grade 2 or higher occurred in $\geq 1\%$ of patients treated with BIKTARVY in Study 1490.

8.3 Less Common Clinical Trial Adverse Reactions

Additional adverse reactions (all Grades) occurring in less than 2% of patients administered BIKTARVY in Studies 1489 and 1490:

Gastrointestinal disorders: abdominal pain, dyspepsia, flatulence, vomiting

Psychiatric Disorders: depression

Skin and subcutaneous tissue disorders: rash

Suicidal ideation or suicide attempt (in patients with a pre-existing history of depression or psychiatric illness) occurred in $< 1\%$ of subjects administered BIKTARVY.

The majority of adverse reactions were Grade 1.

8.4 Abnormal Laboratory Findings: Hematologic, Clinical Chemistry and Other Quantitative Data

The frequency of laboratory abnormalities (Grades 3–4) occurring in at least 2% of patients receiving BIKTARVY in Studies 1489 and 1490 are presented in Table 4 and Table 5, respectively.

Table 4 Laboratory Abnormalities (Grades 3–4) Reported in $\geq 2\%$ of Patients Receiving BIKTARVY in Study 1489 (Week 48 and 96 analysis)

Laboratory Parameter Abnormality ^a	Week 48		Week 96	
	BIKTARVY N=314 (%)	ABC/DTG/3TC N=315 (%)	BIKTARVY N=314 (%)	ABC/DTG/3TC N=315 (%)
Amylase ($>2.0 \times$ ULN)	2	2	3	3
ALT ($>5.0 \times$ ULN)	1	1	2	2
AST ($>5.0 \times$ ULN)	2	1	4	3
Creatine Kinase ($\geq 10.0 \times$ ULN)	4	3	6	5
Neutrophils ($<750 \text{ mm}^3$)	2	3	3	4
LDL-cholesterol (fasted) ($>190 \text{ mg/dL}$)	2	3	3	4

ULN = Upper limit of normal

a. Frequencies are based on treatment-emergent laboratory abnormalities.

Table 5 Laboratory Abnormalities (Grades 3–4) Reported in ≥ 2% of Patients Receiving BIKTARVY in Study 1490 (Week 48 and 96 analysis)

Laboratory Parameter Abnormality ^a	Week 48		Week 96	
	BIKTARVY N=320 (%)	DTG + FTC/TAF N=325 (%)	BIKTARVY N=320 (%)	DTG + FTC/TAF N=325 (%)
Amylase (>2.0 x ULN)	2	2	2	3
ALT (>5.0 x ULN)	2	1	3	1
AST (>5.0 x ULN)	1	3	2	3
Creatine Kinase (≥10.0 x ULN)	4	2	5	3
Neutrophils (<750 mm ³)	2	1	3	1
LDL-cholesterol (fasted) (>190 mg/dL)	3	4	4	4

ULN = Upper limit of normal

a. Frequencies are based on treatment-emergent laboratory abnormalities.

Changes in Serum Creatinine: Bictegravir has been shown to increase serum creatinine due to inhibition of tubular secretion of creatinine without affecting renal glomerular function [see **ACTION AND CLINICAL PHARMACOLOGY**]. Increases in serum creatinine occurred by Week 4 of treatment and remained stable through Week 96. In Studies 1489 and 1490, median (Q1, Q3) serum creatinine increased by 0.09 (0.01, 0.16) mg per dL, 0.09 (0.03, 0.17) mg per dL, and 0.11 (0.04, 0.18) mg per dL from baseline to Week 96 in the BIKTARVY, ABC/DTG/3TC, and DTG+FTC/TAF groups, respectively. There were no discontinuations due to renal adverse events through Week 96 in patients administered BIKTARVY in clinical studies.

Changes in Bilirubin: In Studies 1489 and 1490, total bilirubin increases were observed in 15% of patients administered BIKTARVY through Week 96. Increases were primarily Grade 1 (11%) and Grade 2 (4%) (≥1.0 to 2.5 x ULN) and were not associated with hepatic adverse reactions or other liver related laboratory abnormalities. Four patients administered BIKTARVY (1%) had Grade 3 bilirubin increases that were not considered related to study drug. There were no discontinuations due to hepatic adverse events through Week 96 in BIKTARVY clinical studies.

Adverse Reactions from Clinical Trials of the Components of BIKTARVY

For information on the safety profiles of emtricitabine or tenofovir alafenamide, consult the Product Monographs for EMTRIVA[®], VEMLIDY[®] or DESCOVY[®].

8.5 Clinical Trials in Virologically Suppressed Adults

The safety of BIKTARVY in virologically suppressed adults was based on Week 48 data from 282 patients in a randomized, double-blind, active-controlled trial (Study 1844) in which virologically suppressed patients were switched from either DTG + ABC/3TC or ABC/DTG/3TC to BIKTARVY; and Week 48 data from 290 patients in an open-label, active-controlled trial in which virologically suppressed patients were switched from a regimen containing atazanavir (ATV) (given with cobicistat or ritonavir) or darunavir (DRV) (given with cobicistat or ritonavir) plus either FTC/TDF or ABC/3TC, to BIKTARVY (Study 1878). Overall, the safety profile in virologically suppressed adult patients in Studies 1844 and 1878 was similar to that in treatment-naïve patients.

8.6 Clinical Trials in Pediatric Patients (6 to < 18 years of age)

The safety of BIKTARVY was evaluated in 50 HIV-1 infected virologically suppressed patients between the ages of 12 to < 18 years (weighing \geq 35 kg) through Week 48 and in 50 virologically suppressed patients between the ages of 6 to < 12 years (weighing \geq 25 kg) through Week 24 in an open label clinical study, GS-US-380-1474 (Study 1474). In Study 1474, the safety profile of BIKTARVY was similar to that in adults. Adverse reactions were reported in 10% of pediatric subjects. No Grade 3 or 4 adverse reactions were reported. One subject (1%) had Grade 2 adverse reactions of insomnia and anxiety that led to discontinuation of BIKTARVY. The other adverse reactions that occurred in single subjects were similar to those seen in adults.

8.7 Post-Market Adverse Reactions

In addition to the adverse reaction reports from clinical trials, the following possible adverse reactions have been identified during post-approval use of products containing emtricitabine or tenofovir alafenamide. Because these events have been reported voluntarily from a population of unknown size, estimates of frequency cannot be made. These events have been considered possible adverse reactions due to a combination of their seriousness, frequency of reporting or potential causal relationship with treatment. No additional adverse reactions have been identified during post-approval use of other components of BIKTARVY.

Emtricitabine

The following adverse experiences have been reported in post-marketing experience without regard to causality; some events represent a single report.

<i>Blood and lymphatic system disorders:</i>	Thrombocytopenia
<i>Gastrointestinal disorders:</i>	Pancreatitis
<i>General disorders and administrative site conditions:</i>	Pyrexia
<i>Metabolism and nutrition disorders:</i>	Lactic acidosis

Tenofovir Alafenamide

<i>Skin and subcutaneous tissue disorders:</i>	Angioedema, urticaria
--	-----------------------

9 DRUG INTERACTIONS

Serious Drug Interactions

Coadministration of BIKTARVY is contraindicated with:

- Dofetilide* due to the potential for increased dofetilide plasma concentrations and associated serious and/or life-threatening events (see **Drug-Drug Interactions**)
- Rifampin due to decreased bictegravir plasma concentrations, which may result in the loss of therapeutic effect and development of resistance of BIKTARVY (see **Drug-Drug Interactions**)
- St. John's wort due to the effect of St. John's wort on the bictegravir component of BIKTARVY which may result in loss of therapeutic effect and development of resistance (see **Drug-Drug Interactions**).

*Product not marketed in Canada

9.1 Overview

The drug interactions described in Table 6 are based on studies conducted with BIKTARVY, or the components of BIKTARVY (bictegravir, emtricitabine, or tenofovir alafenamide) as individual components and/or in combination, or are potential drug interactions that may occur with BIKTARVY. The table is not comprehensive.

Potential for BIKTARVY to Affect Other Drugs

Bictegravir inhibits organic cation transporter 2 (OCT2) and multidrug and toxin extrusion transporter 1 (MATE1) *in vitro*. Coadministration of BIKTARVY with the OCT2 and MATE1 substrate metformin did not result in a clinically significant increase in metformin exposure. BIKTARVY may be coadministered with substrates of OCT2 and MATE1 except dofetilide*, which is contraindicated due to the potential for increased dofetilide plasma concentrations and associated serious and/or life-threatening events (see **CONTRAINDICATIONS**).

*Product not marketed in Canada

Bictegravir is not an inhibitor or inducer of CYP3A *in vivo*.

Emtricitabine

In vitro and clinical pharmacokinetic drug-drug interaction studies have shown that the potential for CYP-mediated interactions involving FTC with other medicinal products is low.

FTC is primarily excreted by the kidneys by a combination of glomerular filtration and active tubular secretion. No drug-drug interactions due to competition for renal excretion have been observed; however, coadministration of FTC with drugs that are eliminated by active tubular secretion may increase concentrations of FTC, and/or the coadministered drug.

Drugs that decrease renal function may increase concentrations of FTC.

Tenofovir Alafenamide

TAF is a substrate of P-gp and BCRP. Drugs that strongly affect P-gp and BCRP activity may

lead to changes in TAF absorption.

TAF is not an inhibitor or inducer of CYP3A *in vivo*.

Potential for Other Drugs to Affect One or More Components of BIKTARVY

Bictegravir, a component of BIKTARVY, is a substrate of CYP3A and UGT1A1. Coadministration of bictegravir and drugs that potently induce both CYP3A and UGT1A1 may significantly decrease plasma concentrations of bictegravir, which may result in loss of therapeutic effect of BIKTARVY and development of resistance. Coadministration of bictegravir with drugs that potently inhibit both CYP3A and UGT1A1 may significantly increase plasma concentrations of bictegravir.

TAF, a component of BIKTARVY, is a substrate of P-gp and BCRP. Drugs that strongly affect P-gp and BCRP activity may lead to changes in TAF absorption (see Table 6). Drugs that induce P-gp activity are expected to decrease the absorption of TAF, resulting in decreased plasma concentration of TAF, which may lead to loss of therapeutic effect of BIKTARVY and development of resistance. Coadministration of BIKTARVY with other drugs that inhibit P-gp and BCRP may increase the absorption and plasma concentration of TAF (see Table 9).

9.2 Drug-Drug Interactions

Drug-drug interaction studies were conducted with BIKTARVY or various combinations of the components of BIKTARVY (bictegravir, FTC or TAF).

BIKTARVY should not be coadministered with atazanavir due to a potential drug interaction. As BIKTARVY is a complete regimen, comprehensive information regarding drug-drug interactions with other antiretrovirals agents is not provided.

Drug interaction information for BIKTARVY with potential concomitant drugs is summarized in Table 6. The drug interactions described are based on studies conducted with either BIKTARVY, the components of BIKTARVY (bictegravir, FTC, and TAF) as individual agents, or are predicted drug interactions that may occur with BIKTARVY. For contraindicated drugs, see **CONTRAINDICATIONS**. For magnitude of interaction, see **Drug Interaction Studies**.

The table is not all-inclusive.

Table 6 Established or Potential^a Drug-Drug Interactions

Concomitant Drug Class: Drug Name	Effect on Concentration^b	Clinical Comment
Anticonvulsants: carbamazepine ^c oxcarbazepine phenobarbital phenytoin	↓ bictegravir ↓ TAF	Coadministration of carbamazepine, oxcarbazepine, phenobarbital, or phenytoin may decrease bictegravir and TAF plasma concentrations, which may result in loss of therapeutic effect and development of resistance. Therefore it is not recommended. Alternative anticonvulsants should be considered.
Antimycobacterials: rifabutin ^c rifampin ^{c,d} rifapentine	↓ bictegravir ↓ TAF	Coadministration of rifabutin, rifampin, or rifapentine may decrease bictegravir and TAF plasma concentrations, which may result in loss of therapeutic effect and development of resistance. Coadministration of BIKTARVY with rifampin is contraindicated due to the effect of rifampin on the bictegravir component of BIKTARVY [see CONTRAINDICATIONS]. Coadministration of BIKTARVY with rifabutin or rifapentine is not recommended.
HIV-1 Antiviral Agent: atazanavir ^{c,e}	↑ bictegravir	Coadministration of BIKTARVY with atazanavir is not recommended.
Herbal Products: St. John's wort (<i>Hypericum perforatum</i>)	↓ bictegravir ↓ TAF	Coadministration of BIKTARVY with St. John's wort is contraindicated.
Medications or oral supplements containing polyvalent cations (e.g. Mg, Al, Ca, Fe): Calcium or iron supplements ^c Cation-containing antacids or laxatives ^c Sucralfate Buffered medications	↓ bictegravir	Administer BIKTARVY 2 hours before or 2 hours after taking medications or oral supplements containing polyvalent cations. Alternatively, BIKTARVY and medications or oral supplements containing polyvalent cations can be taken together with food.

- a Table is not all inclusive
 b ↑ = increase, ↓ = decrease
 c Drug-drug interaction study was conducted.
 d Potent inducer of both CYP3A and UGT1A1.
 e Potent inhibitor of both CYP3A and UGT1A1.

9.3 Drug Interaction Studies

Drug-drug interaction studies were conducted with BIKTARVY or various combinations of BIKTARVY components (bictegravir, FTC or TAF).

The effects of coadministered drugs on the exposure of bictegravir are shown in Table 7. The effects of coadministered drugs on the exposure of tenofovir alafenamide (TAF) are shown in Table 8. The effects of bictegravir and /or TAF on the exposure of coadministered drugs are shown in Table 9.

Drugs without Clinically Significant Interactions with BIKTARVY

Based on drug interaction studies conducted with BIKTARVY or the components of BIKTARVY, no clinically significant drug interactions have been either observed or are expected when BIKTARVY is combined with the following drugs: amlodipine, atorvastatin, buprenorphine, drospirenone, ethinyl estradiol, famciclovir, famotidine, fluticasone, itraconazole, ketoconazole, ledipasvir/sofosbuvir, metformin, methadone, midazolam, naloxone, norbuprenorphine, norgestimate, omeprazole, sertraline, sofosbuvir, sofosbuvir/velpatasvir, and sofosbuvir/velpatasvir/voxilaprevir.

Table 7 Drug Interactions: Changes in Pharmacokinetic Parameters for Bictegravir in the Presence of the Coadministered Drug^a

Coadministered Drug	Dose of Coadministered Drug (mg)	Bictegravir (mg)	N	Mean % Change of Bictegravir Pharmacokinetic Parameters (90% CI) ^b		
				C _{max}	AUC	C _{min}
Atazanavir ^c (fed)	300+150 cobicistat once daily	75 single dose	15	↔	↑ 306% (↑276%, ↑337%)	NA
Atazanavir ^d (fed)	400 once daily	75 single dose	15	↔	↑ 315% (↑281%, ↑351%)	NA
Darunavir ^e (fed)	800+150 cobicistat once daily	75 once daily	13	↑ 52% (↑40%, ↑64%)	↑ 74% (↑62%, ↑87%)	↑ 111% (↑95%, ↑129%)
Ledipasvir/ Sofosbuvir (fed)	90/400 once daily	75 once daily	30	↔	↔	↔
Rifabutin (fasted)	300 once daily	75 once daily	13	↓ 20% (↓33%, ↓3%)	↓ 38% (↓47%, ↓28%)	↓ 56% (↓63%, ↓48%)
Rifampin (fed)	600 once daily	75 single dose	15	↓ 28% (↓33%, ↓22%)	↓ 75% (↓78%, ↓73%)	NA
Sofosbuvir/ velpatasvir/ voxilaprevir (fed)	400/100/100+100 voxilaprevir ^f once daily	50 once daily	30	↔	↔	↔
Voriconazole ^e (fasted)	300 twice daily	75 single dose	15	↔	↑ 61% (↑41%, ↑84%)	NA
Medications or Oral Supplements Containing Polyvalent Cations						
Maximum strength antacid (simultaneous administration, fasted)	20 mL ^g single dose (oral)	50 single dose	14	↓ 80% (↓84%, ↓76%)	↓ 79% (↓82%, ↓74%)	NA
Maximum strength antacid (2 h after BIKTARVY fasted)	20 mL ^g single dose (oral)	50 single dose	13	↔	↔	NA
Maximum strength antacid (2 h before BIKTARVY fasted)	20 mL ^g single dose (oral)	50 single dose	13	↓ 58% (↓67%, ↓48%)	↓ 52% (↓62%, ↓41%)	NA
Maximum strength antacid (simultaneous administration, fed ^h)	20 mL ^g single dose (oral)	50 single dose	14	↓ 49% (↓57%, ↓38%)	↓ 47% (↓56%, ↓36%)	NA

Coadministered Drug	Dose of Coadministered Drug (mg)	Bictegravir (mg)	N	Mean % Change of Bictegravir Pharmacokinetic Parameters (90% CI) ^b		
				C _{max}	AUC	C _{min}
Calcium carbonate (simultaneous administration, fasted)	1200 single dose	50 single dose	14	↓ 42% (↓49%, ↓33%)	↓ 33% (↓43%, ↓22%)	NA
Calcium carbonate (simultaneous administration, fed ^h)	1200 single dose	50 single dose	14	↔	↔	NA
Ferrous fumarate (simultaneous administration, fasted)	324 single dose	50 single dose	14	↓ 71% (↓74%, ↓67%)	↓ 63% (↓67%, ↓58%)	NA
Ferrous fumarate (simultaneous administration, fed ^h)	324 single dose	50 single dose	14	↓ 25% (↓35%, ↓13%)	↔	NA

NA = Not Available / Not Applicable; 90% CIs of the GLSM ratio were within (↔), extended above (↑), or extended below (↓) the predetermined No Effect Boundaries.

- All interaction studies conducted in healthy volunteers.
- All No Effect Boundaries are 70% -143%.
- Evaluated as a potent inhibitor of CYP3A, UGT1A1, and an inhibitor of P-gp.
- Evaluated as a potent inhibitor of CYP3A and UGT1A1.
- Evaluated as a potent inhibitor of CYP3A.
- Study conducted with additional voxilaprevir 100 mg to achieve voxilaprevir exposures expected in HCV-infected patients.
- Maximum strength antacid contained 80 mg aluminum hydroxide, 80 mg magnesium hydroxide, and 8 mg simethicone, per mL.
- Reference treatment administered under fasted conditions.

Table 8 Drug Interactions: Changes in Pharmacokinetic Parameters for Tenofovir Alafenamide in the Presence of the Coadministered Drug^a

Coadministered Drug	Dose of Coadministered Drug (mg)	Tenofovir Alafenamide (mg)	N	Mean % Change of Tenofovir Alafenamide Pharmacokinetic Parameters (90% CI) ^b		
				C _{max}	AUC	C _{min}
Carbamazepine	300 twice daily	25 single dose ^c	22	↓57% (↓64%, ↓49%)	↓54% (↓60%, ↓46%)	NA
Ledipasvir/sofosbuvir	90/400 once daily	25 once daily	30	↔	↔	NA
Sofosbuvir/velpastavir/voxilaprevir	400/100/100+100 voxilaprevir ^d once daily	25 once daily	30	↑28% (↑9%, ↑51%)	↑57% (↑44%, ↑71%)	NA

NA= Not Available / Not Applicable; 90% CIs of the GLSM ratio were within (↔), extended above (↑), or extended below (↓) the predetermined No Effect Boundaries

- All interaction studies conducted in healthy volunteers.
- All No Effect Boundaries are 70% -143% unless otherwise specified.
- Study conducted with DESCOVY (emtricitabine/tenofovir alafenamide).
- Study conducted with additional voxilaprevir 100 mg to achieve voxilaprevir exposures expected in HCV-infected patients.

Table 9 Drug Interactions: Changes in Pharmacokinetic Parameters for Coadministered Drug in the Presence of the Individual Components of BIKTARVY^a

Coadministered Drug	Dose of Coadministered Drug (mg)	Bictegravir (mg)	Tenofovir Alafenamide (mg)	N	Mean % Change of Coadministered Drug Pharmacokinetic Parameters (90% CI) ^b		
					C _{max}	AUC	C _{min}
Ledipasvir	90/400 once daily	75 once daily	25 once daily	30	↔	↔	↔
Sofosbuvir					↔	↔	NA
GS-331007 ^c					↔	↔	↔
Metformin	500 twice daily	50 once daily	25 once daily	30	↔	↑39% (↑31%, ↑48%)	↑36% (↑21%, ↑53%)
Midazolam	2 single dose	50 once daily	25 once daily	14	↔	↔	NA
Norelgestromin	norgestimate 0.180/0.215/0.250 once daily / ethinyl estradiol 0.025 once daily	75 once daily	-	15	↔	↔	↔
Norgestrel					↔	↔	↔
Ethinyl estradiol					↔	↔	↔
Norelgestromin	norgestimate 0.180/0.215/0.250 once daily / ethinyl estradiol 0.025 once daily	-	25 once daily ^d	14	↔	↔	↔
Norgestrel					↔	↔	↔
Ethinyl estradiol					↔	↔	↔
Sertraline	50 single dose	-	10 once daily ^e	19	↔	↔	NA
Sofosbuvir	400//100/100 + 100 ^f once daily	50 once daily	25 once daily	30	↔	↔	NA
GS-331007 ^c					↔	↔	↔
Velpatasvir					↔	↔	↔
Voxilaprevir					↔	↔	↔

NA = Not Available / Not Applicable; 90% CIs of the GLSM ratio were within (↔), extended above (↑), or extended below (↓) the predetermined No Effect Boundaries

- a. All interaction studies conducted in healthy volunteers.
- b. All No Effect Boundaries are 70% -143% unless otherwise specified.
- c. The predominant circulating nucleoside metabolite of sofosbuvir.
- d. Study conducted with DESCOVY (emtricitabine/tenofovir alafenamide).
- e. Study conducted with GENVOYA (elvitegravir/cobicistat/emtricitabine/tenofovir alafenamide).
- f. Study conducted with additional voxilaprevir 100 mg to achieve voxilaprevir exposures expected in HCV-infected patients.

9.4 Drug-Food Interactions

The effect of food on the components of the BIKTARVY was evaluated with a high (~800 calories, 50% from fat) or moderate fat (600 calories, 27% from fat) meal relative to fasted conditions.

Relative to fasting conditions, the administration of BIKTARVY with a moderate or high fat meal resulted in a 24% increase in bictegravir exposure. The alterations in mean systemic exposures of bictegravir were not clinically significant.

Relative to fasting conditions, the exposure to emtricitabine was similar following administration of BIKTARVY with a moderate or high fat meal.

Relative to fasting conditions, the administration of BIKTARVY with a moderate or high fat meal resulted in a 48% and 63% increase in TAF exposures, respectively. The alterations in mean systemic exposures of TAF were not clinically significant.

BIKTARVY may be administered without regard to food.

9.5 Drug-Herb Interactions

Coadministration of St. John's wort may significantly decrease bictegravir and tenofovir alafenamide plasma concentrations, which may result in loss of therapeutic effect and development of resistance.

Coadministration of BIKTARVY with St. John's wort is contraindicated.

9.6 Drug-Laboratory Test Interactions

Interactions of BIKTARVY with laboratory tests have not been established.

9.7 Drug-Lifestyle Interactions

Interactions of BIKTARVY with lifestyle have not been established.

10 ACTION AND CLINICAL PHARMACOLOGY

10.1 Mechanism of Action

BIKTARVY is a fixed-dose combination, single tablet regimen of the antiviral drugs bictegravir, emtricitabine (FTC) and tenofovir alafenamide (TAF).

Bictegravir

Bictegravir is an integrase strand transfer inhibitor (INSTI) that binds to the integrase active site

and blocks the strand transfer step of retroviral deoxyribonucleic acid (DNA) integration which is essential for the HIV replication cycle.

Bictegravir has activity that is specific to human immunodeficiency virus (HIV-1 and HIV-2).

Emtricitabine

FTC is a nucleoside analogue of 2'-deoxycytidine. FTC is phosphorylated by cellular enzymes to form FTC triphosphate. FTC triphosphate inhibits HIV replication through incorporation into viral DNA by the HIV reverse transcriptase, which results in DNA chain-termination.

FTC has activity that is specific to human immunodeficiency virus (HIV-1 and HIV-2) and hepatitis B virus.

FTC triphosphate is a weak inhibitor of mammalian DNA polymerases that include mitochondrial DNA polymerase γ and there was no evidence of toxicity to mitochondria *in vitro* and *in vivo*.

Tenofovir Alafenamide

TAF is a phosphoramidate prodrug of tenofovir (2'-deoxyadenosine monophosphate analogue). TAF is permeable into cells and due to increased plasma stability and intracellular activation through hydrolysis by cathepsin A, TAF is more efficient than TDF in loading tenofovir into peripheral blood mononuclear cells (PBMCs) (including lymphocytes and other HIV target cells) and macrophages. Intracellular tenofovir is subsequently phosphorylated to the pharmacologically active metabolite tenofovir diphosphate. Tenofovir diphosphate inhibits HIV replication through incorporation into viral DNA by the HIV reverse transcriptase, which results in DNA chain-termination.

Tenofovir has activity that is specific to human immunodeficiency virus (HIV-1 and HIV-2) and hepatitis B virus. *In vitro* studies have shown that both FTC and tenofovir can be fully phosphorylated when combined in cells. Tenofovir diphosphate is a weak inhibitor of mammalian DNA polymerases that include mitochondrial DNA polymerase γ and there is no evidence of mitochondrial toxicity *in vitro* based on several assays including mitochondrial DNA analyses.

10.2 Pharmacodynamics

Effects on Electrocardiogram

Bictegravir

In a thorough QT/QTc study in 48 healthy subjects, bictegravir at supratherapeutic doses of 1.5 and 6 times the recommended therapeutic dose did not affect the QT/QTc interval and did not prolong the PR interval.

Tenofovir Alafenamide

In a thorough QT/QTc study in 48 healthy subjects, TAF at the therapeutic dose or at a supratherapeutic dose approximately 5 times the recommended therapeutic dose did not affect the QT/QTc interval and did not prolong the PR interval.

Emtricitabine

The effect of FTC on the QT interval is not known.

Effects on Serum Creatinine

The effect of bictegravir on renal function was evaluated in a randomized, blinded, parallel, placebo-controlled trial in 40 healthy subjects who received bictegravir 75 mg (n=20) or placebo (n=20) once daily with food for 14 days. Mean change from baseline in serum creatinine in the bictegravir group was 0.1 mg per dL on Days 7 and 14. Bictegravir did not have a significant effect on the estimated glomerular filtration rate or on the actual glomerular filtration rate (determined by the clearance of probe drug, iohexol) compared with placebo.

10.3 Pharmacokinetics

The pharmacokinetic (PK) properties of the components of BIKTARVY are provided in Table 10. The multiple dose PK parameters of the components of BIKTARVY are provided in Table 11.

Table 10 Pharmacokinetic Properties of the Components of BIKTARVY

	Bictegravir	Emtricitabine	Tenofovir Alafenamide
Absorption			
T _{max} (h) ^a	2.0-4.0	1.5-2.0	0.5-2.0
Effect of high fat meal (relative to fasting) ^b	AUC ratio = 1.24 (1.16, 1.33) C _{max} Ratio = 1.13 (1.06, 1.20)	AUC Ratio = 0.96 (0.93, 0.99) C _{max} Ratio = 0.86 (0.78, 0.93)	AUC Ratio = 1.63 (1.43, 1.85) C _{max} Ratio = 0.92 (0.73, 1.14)
Distribution			
% Bound to human plasma proteins	>99	<4	~80
Source of protein binding data	<i>In vitro</i>	<i>In vitro</i>	<i>Ex vivo</i>
Blood-to-plasma ratio	0.64	0.6	1.0
Metabolism			
Metabolism	CYP3A UGT1A1	Not significantly metabolized	Cathepsin A ^c (PBMCs) CES1 (hepatocytes)
Elimination			
Major route of elimination	Metabolism	Glomerular filtration and active tubular secretion	Metabolism
t _{1/2} (h) ^d	17.3	10	0.51 ^d
% Of dose excreted in urine ^d	35	70	<1
% Of dose excreted in feces ^e	60.3	13.7	31.7

PBMCs = peripheral blood mononuclear cells; CES1 = carboxylesterase 1

a. Values reflect administration of BIKTARVY with or without food.

b. Values refer to geometric mean ratio [High-fat meal/fasting] in PK parameters and (90% confidence interval). High-calorie/high-fat meal = ~800 kcal, 50% fat.

c. *In vivo*, TAF is hydrolyzed within cells to form tenofovir (major metabolite), which is phosphorylated to the active metabolite, tenofovir diphosphate. *In vitro* studies have shown that TAF is metabolized to tenofovir by cathepsin A in PBMCs and macrophages; and by CES1 in hepatocytes.

d. t_{1/2} values refer to median terminal plasma half-life. Note that the pharmacologically active metabolite of TAF, tenofovir diphosphate, has a half-life of 150-180 hours within PBMCs.

e. Dosing in mass balance studies: bictegravir (single dose administration of [¹⁴C] bictegravir); FTC (single dose administration of [¹⁴C] emtricitabine after multiple dosing of emtricitabine for ten days); TAF (single dose administration of [¹⁴C] tenofovir alafenamide).

Table 11 Multiple Dose PK Parameters of bictegravir, FTC, and TAF Following Oral Administration With or Without Food in HIV-Infected Adults

Parameter	Bictegravir ^a Mean (CV%)	Emtricitabine ^b Mean (CV%)	Tenofovir Alafenamide ^c Mean (CV%)
C _{max} (µg per mL)	6.15 (22.9)	2.13 (34.7)	0.121 (15.4)
AUC _{tau} (µg•h per mL)	102 (26.9)	12.3 (29.2)	0.142 (17.3)
C _{trough} (µg per mL)	2.61 (35.2)	0.096 (37.4)	NA

CV = Coefficient of Variation; NA = Not Applicable

a. From Population PK analysis in Studies 1489, 1490, 1844, and 1878; N=1193.

b. From Intensive PK analysis in Studies 1489, 1490, 1844, and 1878; N=77.

c. From Population PK analysis in Studies 1489 and 1490; N=486.

Linearity/Non-linearity

Bictegravir

The multiple dose pharmacokinetics of bictegravir are dose proportional over the dose range of 25 to 100 mg.

Emtricitabine

The multiple dose pharmacokinetics of FTC are dose proportional over the dose range of 25 to 200 mg.

Tenofovir Alafenamide

TAF exposures are dose proportional over the dose range of 8 mg to 125 mg.

Special Populations and Conditions

Geriatrics: The pharmacokinetics of bictegravir, FTC, and TAF have not been fully evaluated in the elderly (65 years of age and older). Population pharmacokinetics analysis of HIV-infected patients in Phase 3 trials of BIKTARVY showed that age did not have a clinically relevant effect on exposures of bictegravir and TAF up to 74 years of age.

Pediatrics: Mean BIC C_{trough} was lower in 50 pediatric patients aged 12 to < 18 years (≥ 35 kg) who received BIKTARVY in Study 1474 relative to adults following administration of BIKTARVY, but was not considered clinically significant based on exposure-response relationships; exposures of FTC and TAF in these pediatric patients were similar to those in adults (Table 12).

Table 12 Multiple Dose PK Parameters of BIC, FTC, and TAF Following Oral Administration of BIKTARVY in HIV-Infected Pediatric Subjects Aged 12 to < 18 years and Weighing ≥ 35 kg (Adolescents)

Parameter	Bictegravir ^a Mean (CV%)	Emtricitabine ^b Mean (CV%)	Tenofovir Alafenamide ^a Mean (CV%)
C _{max} (µg per mL)	6.24 (27.1)	2.69 (34.0)	0.133 (70.2)
AUC _{tau} (µg·h per mL)	89.1 (31.0)	13.6 (21.7)	0.196 (50.3)
C _{trough} (µg per mL)	1.78 (44.4)	0.064 (25.0)	NA

CV=Coefficient of Variation; NA=Not Applicable

a. From Population PK analysis of Cohort 1 of Trial 1474 (n=50 for BIC; n=49 for TAF).

b. From Intensive PK analysis of Cohort 1 of Trial 1474 (n=24).

Mean BIC C_{max}, and exposures of FTC and TAF (AUC_{tau} and C_{max}) achieved in 50 pediatric patients between the ages of 6 to < 12 years and weighing ≥ 25 kg who received BIKTARVY in Study 1474 were higher than exposures in adults; however, the increase was not considered clinically significant as the safety profiles were similar in adult and pediatric patients (**Table 13**).

Table 13 Multiple Dose PK Parameters of BIC, FTC, and TAF Following Oral Administration of BIKTARVY in HIV-Infected Pediatric Subjects Aged 6 to < 12 years and Weighing ≥ 25 kg (Children)

Parameter	Bictegravir ^a Mean (CV%)	Emtricitabine ^b Mean (CV%)	Tenofovir Alafenamide ^a Mean (CV%)
C _{max} (µg per mL)	9.46 (24.3)	3.89 (31.0)	0.205 (44.6)
AUC _{tau} (µg·h per mL)	128 (27.8)	17.6 (36.9)	0.278 (40.3)
C _{trough} (µg per mL)	2.36 (39.0)	0.227 (323)	NA

CV=Coefficient of Variation; NA=Not Applicable

a. From Population PK analysis of Cohort 2 of Trial 1474 (n=50 for BIC; n=47 for TAF).

b. From Intensive PK analysis of Cohort 2 of Trial 1474 (n=25 except n=24 for C_{trough}).

Sex: Based on population pharmacokinetic analyses, no dosage adjustment for BIKTARVY is recommended based on gender.

Ethnic origin: Based on population pharmacokinetic analyses, no dosage adjustment for BIKTARVY is recommended based on race.

Hepatic Insufficiency:

Bictegravir

Clinically relevant changes in the pharmacokinetics of bictegravir were not observed in subjects with moderate (Child-Pugh Class B) hepatic impairment.

Emtricitabine

The pharmacokinetics of emtricitabine have not been studied in subjects with hepatic

impairment; however, emtricitabine is not significantly metabolized by liver enzymes; therefore, the impact of liver impairment should be limited.

Tenofovir Alafenamide

Clinically relevant changes in the pharmacokinetics of tenofovir alafenamide or its metabolite tenofovir were not observed in subjects with mild, moderate, or severe (Child-Pugh Class A, B and C) hepatic impairment; no tenofovir alafenamide dose adjustment is required in subjects with hepatic impairment.

Renal Insufficiency:

No clinically relevant differences in bictegravir, tenofovir alafenamide, or tenofovir pharmacokinetics were observed between healthy subjects and subjects with severe renal impairment (estimated creatinine clearance less than 30 mL per minute). There are no pharmacokinetic data on bictegravir or tenofovir alafenamide in patients with creatinine clearance less than 15 mL per minute.

Hepatitis B and/or Hepatitis C Virus Coinfection

Pharmacokinetics of bictegravir, emtricitabine, and tenofovir alafenamide have not been fully evaluated in patients coinfecting with hepatitis B and/or C virus.

11 STORAGE, STABILITY AND DISPOSAL

Dispense only in original container. Keep the bottle tightly closed. Do not use if seal over bottle opening is broken or missing. Store below 30°C.

12 SPECIAL HANDLING INSTRUCTIONS

There are no special handling instructions.

PART II: SCIENTIFIC INFORMATION

13 PHARMACEUTICAL INFORMATION

BIKTARVY (bictegravir, emtricitabine, and tenofovir alafenamide) is a fixed dose combination, single tablet regimen containing bictegravir, emtricitabine (FTC), and tenofovir alafenamide (TAF) for oral administration.

Each tablet contains 50 mg of bictegravir (equivalent to 52.5 mg of bictegravir sodium), 200 mg of FTC, and 25 mg of TAF (equivalent to 28.0 mg of tenofovir alafenamide fumarate) and the following inactive ingredients: croscarmellose sodium, magnesium stearate, and microcrystalline cellulose. The tablets are film-coated with a coating material containing iron oxide black, iron oxide red, polyethylene glycol, polyvinyl alcohol, talc, and titanium dioxide.

Bictegravir

Drug Substance

Common Name: bictegravir sodium (USAN)

Chemical Name: Sodium (2R,5S,13aR)-7,9-dioxo-10-[(2,4,6-trifluorobenzyl)carbamoyl]-2,3,4,5,7,9,13,13a-octahydro-2,5-methanopyrido[1',2':4,5]pyrazino[2,1-b][1,3]oxazepin-8-olate

Empirical formula: $C_{21}H_{17}F_3N_3NaO_5$

Molecular Weight: 471.4

Structural formula:

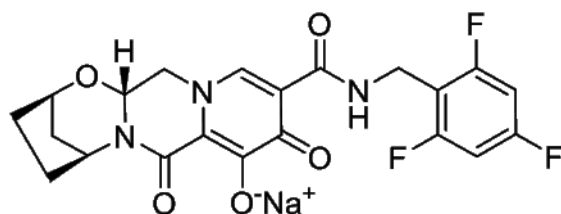

Physicochemical Properties:

Description: Bictegravir is a white to off-white to yellow solid.

Solubility: The solubility is approximately 0.1 mg per mL in water at 20°C. The partition coefficient (log P) is 1.45 and the pKa is 8.6.

Emtricitabine

Drug Substance

Common Name: emtricitabine (USAN)

Chemical Name: 5-fluoro-1-(2R,5S)-[2-(hydroxymethyl)-1,3-oxathiolan-5-yl]cytosine

Empirical Formula: $C_8H_{10}FN_3O_3S$

Molecular Weight: 247.24

Structural Formula:

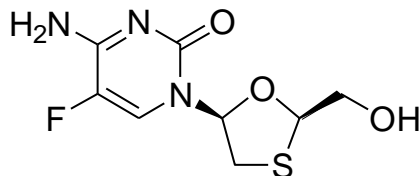

Physicochemical Properties:

Description: Emtricitabine is a white to off-white crystalline powder.

Solubility: The solubility is approximately 112 mg/mL in water at 25 °C. The partition coefficient (log P) is -0.43 and the pKa is 2.65.

Tenofovir alafenamide

Drug Substance

Common Name: Tenofovir alafenamide hemifumarate
Tenofovir alafenamide fumarate (USAN)

Chemical Name: Propan-2-yl N-[(S)-({[(2R)-1-(6-amino-9H-purin-9-yl)propan-2-yl]-oxy)methyl](phenoxy)phosphoryl]-l-alaninate, (2E)-but-2-enedioate (2:1)

Empirical Formula: C₂₁H₂₉O₅N₆P•1/2(C₄H₄O₄)

Molecular Weight: 534.5

Structural Formula:

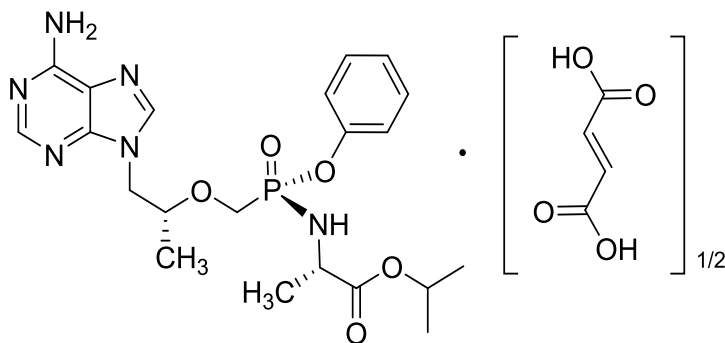

Physicochemical Properties:

Description: TAF hemifumarate is a white to off-white or tan powder.

Solubility: The solubility of TAF hemifumarate in water, pH 8.0 (50 mM phosphate buffer) at 20 °C is 4.86 mg/mL. The partition coefficient (log P) is 1.6 and the pKa is 3.96.

14 CLINICAL TRIALS

The efficacy and safety of BIKTARVY were evaluated in the studies summarized in Table 14.

14.1 Trial Design and Study Demographics

Table 14 Trials Conducted with BIKTARVY in Patients with HIV-1 Infection

Trial	Population	Study Arms (N)	Timepoint (Week)
Study 1489 ^a	Treatment-naïve adults	BIKTARVY (314) ABC/DTG/3TC (315)	96
Study 1490 ^a		BIKTARVY (320) DTG + FTC/TAF(325)	96
Study 1844 ^a	Virologically-suppressed ^c adults	BIKTARVY (282) ABC/DTG/3TC (281)	48
Study 1878 ^b		BIKTARVY (290) ATV or DRV (with cobicistat or ritonavir) plus either FTC/TDF or ABC/3TC (287)	48
Study 1474 ^d Cohort 1	Virologically-suppressed ^c adolescents (Cohort 1: 12 to < 18 years of age; weight ≥ 35 kg)	BIKTARVY (50)	48
Study 1474 ^d Cohort 2	Virologically-suppressed ^c children (Cohort 2: 6 to < 12 years of age; weight ≥ 25 kg)	BIKTARVY (50)	24

a. Randomized, double blind, active controlled trial.

b. Randomized, open label, active controlled trial.

c. HIV-1 RNA less than 50 copies per mL.

d. Open label trial

Treatment-Naïve HIV-1 Infected Patients

The efficacy and safety of Biktarvy in HIV-1 infected, treatment-naïve adults are based on 48-week data from two randomized, double-blind, active-controlled studies, GS-US- 380-1489 (n=629) and GS-US-380-1490 (n=645).

In Study 1489, patients were randomized in a 1:1 ratio to receive either BIKTARVY (N=314) or ABC/DTG/3TC (600/50/300 mg) (N=315) once daily. In Study 1490, patients were randomized in a 1:1 ratio to receive either BIKTARVY (N=320) or DTG + FTC/TAF (50+200/25 mg) (N=325) once daily.

In Study 1489, the mean age was 34 years (range 18–71), 90% were male, 57% were White, 36% were Black, and 3% were Asian. 22% of patients identified as Hispanic or Latino. The mean baseline plasma HIV-1 RNA was 4.4 log₁₀ copies/mL (range 1.3-6.5). The mean baseline CD4+ cell count was 464 cells per mm³ (range 0-1424) and 11% had CD4+ cell counts less than 200 cells per mm³. 16% of patients had baseline viral loads greater than 100,000 copies per mL.

In Study 1489, 0.6% of patients had HIV/HCV coinfection at baseline. In Study 1490, the mean age was 37 years (range 18-77), 88% were male, 59% were White, 31% were Black, and 3% were Asian. 25% of patients identified as Hispanic or Latino. The mean baseline plasma HIV-1 RNA was 4.4 log₁₀ copies/mL (range 2.3-6.6). The mean baseline CD4+ cell count was 456 cells per mm³ (range 2-1636), and 12% had CD4+ cell counts less than 200 cells per mm³. 19% of patients had baseline viral loads greater than 100,000 copies per mL. In Study 1490, 2% of patients had HIV/HBV coinfection and 2% had HIV/HCV coinfection at baseline.

In both studies, patients were stratified by baseline HIV-1 RNA (less than or equal to 100,000 copies/mL, greater than 100,000 copies per mL to less than or equal to 400,000 copies per mL, or greater than 400,000 copies/mL), by CD4 count (less than 50 cells/μL, 50-199 cells/μL, or greater than or equal to 200 cells/μL), and by region (US or ex-US).

For demographic and baseline characteristics for Study 1489 and 1490, see Table 15.

Table 15 Demographic and Baseline Characteristics of Treatment-Naïve Patients in Studies 1489 and 1490

	Study 1489			Study 1490		
	BIKTARVY N = 314 n (%)	ABC/DTG/3TC N = 315 n (%)	Total N = 629 n (%)	BIKTARVY N=320 n (%)	DTG + F/TAF N=325 n (%)	Total N=645 n (%)
Demographic characteristics						
Median age, years (range)	31 (18-71)	32 (18-68)	32 (18-71)	33 (18-71)	34 (18-77)	34 (18-77)
Sex						
Male	285 (91)	282 (90)	567 (90)	280 (88)	288 (89)	568 (88)
Female	29 (9)	33 (10)	62 (10)	40 (13)	37 (11)	77 (12)
Race						
American Indian or Alaska Native	2 (0.6)	4 (1)	6 (1)	1 (0.3)	1 (0.3)	2 (0.3)
Asian	6 (2)	10 (3)	16 (3)	7 (2)	10 (3)	17 (3)
Black	114 (37)	112 (36)	226 (36)	97 (30)	100 (31)	197 (31)
Native Hawaiian or Pacific Islander	1 (0.3)	2 (0.6)	3 (0.5)	1 (0.3)	0	1 (0.2)
White	180 (58)	179 (57)	359 (57)	183 (57)	195 (60)	378 (59)
Other	9 (3)	8 (3)	17 (3)	31 (10)	19 (6)	50 (8)
Not Permitted ^a	2	0	2	-	-	-
Baseline disease characteristics						
Median baseline HIV-1 RNA log ₁₀ copies/mL (range)	4.42 (2.23-6.52)	4.51 (1.28-6.19)	4.47 (1.28-6.52)	4.43 (2.29-6.58)	4.45 (2.76-6.15)	4.44 (2.29-6.58)
Patients with viral load ≤ 100,000 copies/mL	261 (83)	265 (84)	526 (84)	254 (79)	271 (83)	525 (81)
Patients with viral load > 100,000 copies/mL	53 (17)	50 (16)	103 (16)	66 (21)	54 (17)	120 (19)
Patients with CD4+ cell counts < 200 cells/mm ³	36 (11)	32 (10)	68 (11)	44 (14)	34 (10)	78 (12)
HIV disease status						
Asymptomatic	286 (91)	286 (91)	572 (91)	286 (89)	288 (89)	574 (89)

	Study 1489			Study 1490		
	BIKTARVY N = 314 n (%)	ABC/DTG/3TC N = 315 n (%)	Total N = 629 n (%)	BIKTARVY N=320 n (%)	DTG + F/TAF N=325 n (%)	Total N=645 n (%)
Symptomatic HIV infection	16 (5)	14 (4)	30 (5)	10 (3)	11 (3)	21 (3)
AIDS	12 (4)	15 (5)	27 (4)	24 (8)	26 (8)	50 (8)
eGFR _{CG} (mL/min), median (Q1, Q3)	125.9 (107.7, 146.3)	123.0 (107.0, 144.3)	124.8 (107.6, 145.2)	120.4 (100.8, 141.8)	120.6 (102.8, 145.1)	120.6 (102.1, 143.3)
HIV/HBV Coinfection Status ^b						
Yes	0	0	0	8 (3)	6 (2)	14 (2)
No	313 (100)	312 (100)	625 (100)	310 (97)	318 (98)	628 (98)
Missing	1	3	4	2	1	3
HIV/HCV Coinfection Status ^b						
Yes	0	4 (1)	4 (0.6)	5 (2)	5 (2)	10 (2)
No	313 (100)	311 (99)	624 (99)	315 (98)	320 (98)	635 (98)
Missing	1	0	1	-	-	-

- a. Not Permitted = Local regulators did not allow collection of race or ethnicity information.
 For race and ethnicity, patients who reported "Not Permitted" were excluded from the percentage and p-value calculation.
- b. HIV/HBV and HIV/HCV coinfection status were missing when test was not done at screening.

14.2 Study Results

Clinical Trial Results in Treatment-Naïve HIV-1 Infected Patients

Treatment outcomes of Studies 1489 and 1490 through 48 weeks are presented in Table 16.

Table 16 Virologic Outcomes of Randomized Treatment in Studies 1489 and 1490 at Weeks 48^a in Treatment-Naïve Patients

	Week 48			
	Trial 1489		Trial 1490	
	BIKTARVY (N=314)	ABC/DTG/3TC (N=315)	BIKTARVY (N=320)	DTG + FTC/TAF (N=325)
HIV-1 RNA < 50 copies/mL	92%	93%	89%	93%
Treatment Difference (95% CI) BIKTARVY vs. Comparator	-0.6% (-4.8% to 3.6%)		-3.5% (-7.9% to 1.0%)	
HIV-1 RNA ≥ 50 copies/mL^b	1%	3%	4%	1%
No Virologic Data at Week 48 Window	7%	4%	6%	6%
Discontinued Study Drug Due to AE or Death ^c	0	1%	1%	1%
Discontinued Study Drug Due to Other Reasons and Last Available HIV-1 RNA <50 copies/mL ^d	5%	3%	3%	4%
Missing Data During Window but on Study Drug	2%	<1%	2%	1%

a. Week 48 window was between Day 295 and 378 (inclusive).

b. Includes patients who had ≥ 50 copies/mL in the Week 48 window; patients who discontinued early due to lack or loss of efficacy; patients who discontinued for reasons other than an adverse event (AE), death or lack or loss of efficacy and at the time of discontinuation had a viral value of ≥ 50 copies/mL.

c. Includes patients who discontinued due to AE or death at any time point from Day 1 through the time window if this resulted in no virologic data on treatment during the specified window.

d. Includes patients who discontinued for reasons other than an AE, death, or lack or loss of efficacy, e.g., withdrew consent, loss to follow-up, etc

BIKTARVY was noninferior in achieving HIV-1 RNA less than 50 copies per mL at both Weeks 48 and 96 when compared to ABC/DTG/3TC and to DTG+FTC/TAF, respectively. In Study 1489, 88% of patients who received BIKTARVY versus 90% of patients who received ABC/DTG/3TC, had HIV RNA <50 copies/mL at Week 96. In Study 1490, 84% of patients who received BIKTARVY versus 87% of patients who received DTG+FTC/TAF, had HIV RNA <50 copies/mL at Week 96. Treatment outcomes between treatment groups were similar across subgroups by age, sex, race, baseline viral load, and baseline CD4+ cell count up to Week 96.

In Study 1489, the mean increase from baseline in CD4+ count at Week 48 was 233 and 229 cells per mm³, and at Week 96 was 287 and 288 cells per mm³, in the BIKTARVY and ABC/DTG/3TC groups, respectively. In Study 1490, the mean increase from baseline in CD4+ count at Week 48 was 180 and 201 cells per mm³, and at Week 96 was 237 and 281 cells per mm³, in the BIKTARVY and DTG+FTC/TAF groups, respectively.

Clinical Trial Results in HIV-1 Virologically-Suppressed Patients Who Switched to BIKTARVY

In Study 1844, the efficacy and safety of switching from a regimen of DTG + ABC/3TC or ABC/DTG/3TC to BIKTARVY were evaluated in a randomized, double-blind study of virologically-suppressed (HIV-1 RNA less than 50 copies per mL) HIV-1 infected adults (N=563). Patients must have been stably suppressed (HIV-1 RNA less than 50 copies per mL) on their baseline regimen for at least 3 months prior to study entry. Patients were randomized in a 1:1 ratio to either switch to BIKTARVY at baseline (N=282), or stay on their baseline antiretroviral regimen as the FDC of ABC/DTG/3TC (N=281). Patients had a mean age of 45 years (range 20–71), 89% were male, 73% were White, and 22% were Black. 17% of patients identified as Hispanic/Latino. The mean baseline CD4+ cell count was 723 cells per mm³ (range 124–2444). At baseline, one patient had HIV/HCV coinfection.

In Study 1878, the efficacy and safety of switching from either ABC/3TC or FTC/TDF (200/300 mg) plus ATV or DRV (given with either cobicistat or ritonavir) to BIKTARVY were evaluated in a randomized, open-label study of virologically-suppressed HIV-1 infected adults (N=577). Patients must have been stably suppressed on their baseline regimen for at least 6 months and must not have been previously treated with any INSTI. Patients were randomized in a 1:1 ratio to either switch to BIKTARVY (N=290), or stay on their baseline antiretroviral regimen (N=287). Patients had a mean age of 46 years (range 20–79), 83% were male, 66% were White, and 26% were Black. 19% of patients identified as Hispanic/Latino. The mean baseline CD4+ cell count was 663 cells per mm³ (range 62–2582). Patients were stratified by prior treatment regimen (ie, TDF-containing regimen vs non-TDF containing regimen). At screening, 15% of patients were receiving ABC/3TC plus ATV or DRV (given with either cobicistat or ritonavir) and 85% of patients were receiving FTC/TDF plus ATV or DRV (given with either cobicistat or ritonavir). At baseline, 2% of patients had HIV/HBV coinfection and 2% had HIV/HCV coinfection.

For demographic and baseline characteristics for Studies 1844 and 1878, see Table 17.

Table 17 Demographic and Baseline Characteristics of Virologically Suppressed Patients in Studies 1844 and 1878

	Study 1844			Study 1878		
	BIKTARVY N = 282 n (%)	ABC/DTG/3TC N = 281 n (%)	Total N = 563 n (%)	BIKTARVY N=290 n (%)	SBR N=287 n (%)	Total N=577 n (%)
Demographic characteristics						
Median age, years (range)	47 (21-71)	45 (20-70)	46 (20-71)	48 (20-74)	47 (21-79)	48 (20-79)
Sex						
Male	247 (88)	252 (90)	499 (89)	243 (84)	234 (82)	477 (83)
Female	35 (12)	29 (10)	64 (11)	47 (16)	53 (18)	100 (17)
Race						
American Indian or Alaska Native	2 (0.7)	2 (0.7)	4 (0.7)	3 (1)	3 (1)	6 (1)
Asian	9 (3)	9 (3)	18 (3)	6 (2)	10 (3)	16 (3)
Black	59 (21)	62 (22)	121 (22)	79 (27)	72 (25)	151 (26)
Native Hawaiian or Pacific Islander	3 (1)	0	3 (0.5)	0	0	0
White	206 (73)	202 (73)	408 (73)	188 (65)	190 (66)	378 (66)
Other	3 (1)	3 (1)	6 (1)	14 (5)	12 (4)	26 (5)
Not Permitted ^a	0	3	3	-	-	-
Baseline disease characteristics						
Patients with CD4+ cell counts < 200 cells/mm ³	6 (2)	4 (1)	10 (2)	4 (1)	8 (3)	12 (2)
CD4 cell count (cells/mm ³), median (range)	732 (124-2444)	661 (125-1570)	695 (124-2444)	617 (147-2582)	626 (62-1684)	624 (62-2582)
HIV disease status						
Asymptomatic	243 (86)	245 (87)	488 (87)	240 (83)	234 (82)	474 (82)
Symptomatic HIV infection	9 (3)	9 (3)	18 (3)	16 (6)	20 (7)	36 (6)
AIDS	30 (11)	27 (10)	57 (10)	34 (12)	33 (11)	67 (12)
eGFR _{CG} (mL/min), median (Q1, Q3)	100.5 (84.5, 119.0)	100.7 (84.9, 122.4)	100.7 (84.6, 120.1)	106.7 (87.0, 124.2)	104.9 (87.1, 125.3)	105.6 (87.1, 124.8)

	Study 1844			Study 1878		
	BIKTARVY N = 282 n (%)	ABC/DTG/3TC N = 281 n (%)	Total N = 563 n (%)	BIKTARVY N=290 n (%)	SBR N=287 n (%)	Total N=577 n (%)
HIV/HBV Coinfection Status ^b						
Yes	0	0	0	8 (3)	6 (2)	14 (2)
No	282 (100)	281 (100)	563 (100)	278 (97)	280 (98)	558 (98)
Missing	-	-	-	4	1	5
HIV/HCV Coinfection Status ^b						
Yes	0	1 (0.4)	1 (0.2)	5 (2)	5 (2)	10 (2)
No	282 (100)	280 (100)	562 (100)	283 (98)	282 (98)	565 (98)
Missing	-	-	-	2	0	2

- a. Not Permitted = Local regulators did not allow collection of race or ethnicity information.
 For race and ethnicity, patients who reported "Not Permitted" were excluded from the percentage and p-value calculation.
- b. HIV/HBV and HIV/HCV coinfection status were missing when test was not done at screening.

Treatment outcomes of Studies 1844 and 1878 through Week 48 are presented in Table 18.

Table 18 **Virologic Outcomes of Studies 1844 and 1878 at Week 48^a in Virologically-Suppressed Patients who Switched to BIKTARVY**

	Study 1844		Study 1878	
	BIKTARVY (N=282)	ABC/DTG/3TC (N=281)	BIKTARVY (N=290)	ATV- or DRV- based regimen (N=287)
HIV-1 RNA ≥ 50 copies/mL^b	1%	<1%	2%	2%
Treatment Difference (95% CI)	0.7% (-1.0% to 2.8%)		0.0% (-2.5% to 2.5%)	
HIV-1 RNA < 50 copies/mL	94%	95%	92%	89%
Treatment Difference (95% CI)	-1.4% (-5.5% to 2.6%)		3.2% (-1.6% to 8.2%)	

	Study 1844		Study 1878	
	BIKTARVY (N=282)	ABC/DTG/3TC (N=281)	BIKTARVY (N=290)	ATV- or DRV- based regimen (N=287)
No Virologic Data at Week 48 Window	5%	5%	6%	9%
Discontinued Study Drug Due to AE or Death and Last Available HIV-1 RNA < 50 copies/mL	2%	1%	1%	1%
Discontinued Study Drug Due to Other Reasons and Last Available HIV-1 RNA < 50 copies/mL ^c	2%	3%	3%	7%
Missing Data During Window but on Study Drug	2%	1%	2%	2%

- Week 48 window was between Day 295 and 378 (inclusive).
- Includes patients who had ≥ 50 copies/mL in the Week 48 window; patients who discontinued early due to lack or loss of efficacy; patients who discontinued for reasons other than lack or loss of efficacy and at the time of discontinuation had a viral value of ≥ 50 copies/mL.
- Includes patients who discontinued for reasons other than an AE, death, or lack or loss of efficacy, e.g., withdrew consent, loss to follow-up, etc.

In Study 1844, at Week 48, switching to BIKTARVY was noninferior to remaining on ABC/DTG/3TC with respect to the percentage of patients with HIV-1 RNA ≥ 50 copies/mL and the percentage of patients who maintained HIV-1 RNA < 50 copies/mL. Treatment outcomes between treatment groups were similar across subgroups by age, sex, race, and region. The mean change from baseline in CD4+ count at Week 48 was -31 cells/mm³ in patients who switched to BIKTARVY and 4 cells/mm³ in patients who stayed on their baseline antiretroviral regimen as the FDC ABC/DTG/3TC.

In Study 1878, at Week 48, switching to BIKTARVY was noninferior to remaining on an ATV- or DRV-based regimen with respect to the percentage of patients with HIV-1 RNA ≥ 50 copies/mL and the percentage of patients who maintained HIV-1 RNA < 50 copies/mL. Treatment outcomes between treatment groups were similar across subgroups by age, sex, race, and region. The mean change from baseline in CD4+ count at Week 48 was 25 cells/mm³ in patients who switched to BIKTARVY and 0 cells/mm³ in patients who stayed on their baseline regimen.

Bone Mineral Density:

In Study 1489, bone mineral density (BMD) change from baseline to Week 96 was assessed by dual-energy X-ray absorptiometry (DXA). In patients who had both baseline and Week 96 hip and lumbar spine BMD measurements (n=250 and 256 in the BIKTARVY group and n=257 and 258 in the ABC/DTG/3TC group, for hip and lumbar spine, respectively), mean percentage changes in BMD were similar in the BIKTARVY group compared to the ABC/DTG/3TC group for hip (-1.1% vs. -1.3%) and lumbar spine (-0.7% vs. -0.2%).

In Study 1844, BMD change from baseline to Week 48 was assessed by DXA. In patients who had both baseline and Week 48 hip and lumbar spine BMD measurements (N=229 and 233 in the BIKTARVY group and N=242 and 244 in the ABC/DTG/3TC group, for hip and lumbar

spine, respectively), mean percentage increases in BMD were similar in the BIKTARVY group compared to the ABC/DTG/3TC group for hip (0.2% vs. 0.3%) and lumbar spine (0.7% vs.0.4%).

Effects on Renal Parameters

No patients receiving BIKTARVY in the Phase 3 studies developed proximal tubulopathy (including Fanconi Syndrome) or discontinued study drugs due to a renal and urinary disorder or associated investigation AE.

Pediatric Patients

In Study 1474, an open-label, single arm trial the efficacy, safety, and pharmacokinetics of BIKTARVY in HIV-1 infected pediatric patients were evaluated in virologically-suppressed adolescents between the ages of 12 to less than 18 years weighing at least 35 kg (N=50) and in virologically-suppressed children between the ages of 6 to less than 12 years weighing at least 25 kg (N=50). Demographics and baseline characteristics for patients in the 2 study cohorts (Cohort 1: virologically suppressed adolescents [12 to < 18 years; ≥ 35 kg]; Cohort 2: virologically suppressed children [6 to < 12 years; ≥ 25 kg]) are presented in **Table 19**.

Table 19 Demographic and Baseline Characteristics of Virologically Suppressed Pediatric Patients in Study 1474 (Cohort 1 and Cohort 2)

	Study 1474	
	Cohort 1 12 to < 18 years of age (N=50)	Cohort 2 6 to < 12 years of age (N=50)
Demographic characteristics		
Median age, years (range)	15 (12-17)	10 (6-11)
Sex		
Male	18	23
Female	32	27
Race		
Asian	13	11
Black	32	36
Baseline BMI (kg/m ²), median (Q1, Q3)	19.1 (17.8, 22.4)	16.7 (15.6, 18.7)
Baseline disease characteristics		
HIV-1 RNA Category (copies/mL)		
< 50	50	50
≥ 50	0	0
CD4 cell count (cells/μL), median (Q1, Q3)	750 (586, 926)	898 (707, 1121)
eGFR by Schwartz formula (mL/min/1.73 m ²), median (Q1, Q3)	145.0 (134.0, 170.0)	153.5 (144.0, 173.0)

Study results

Cohort 1: Virologically suppressed adolescents (12 to < 18 years; ≥ 35 kg):

After switching to BIKTARVY, 98% (49/50) of patients in Cohort 1 remained suppressed (HIV-1 RNA < 50 copies/mL) at Week 48. The mean change from baseline in CD4+ cell count at Week 48 was -22 cells/mm³. Two of 50 subjects met the criteria for inclusion in the resistance analysis population through Week 48. No emergent resistance to BIKTARVY was detected through Week 48.

Cohort 2: Virologically suppressed children (6 to < 12 years; ≥ 25 kg):

After switching to BIKTARVY, 100% (50/50) of patients in Cohort 2 remained suppressed (HIV-1 RNA < 50 copies/mL) at Week 24. The mean change from baseline in CD4+ cell count at Week 24 was -24 cells/mm³. No patient qualified for resistance analysis through Week 24.

15 MICROBIOLOGY

Antiviral Activity in Cell Culture

The triple combination of bictegravir, FTC, and TAF demonstrated synergistic antiviral activity in cell culture.

Bictegravir: The antiviral activity of bictegravir against laboratory and clinical isolates of HIV-1 was assessed in lymphoblastoid cell lines, PBMCs, primary monocyte/macrophage cells, and CD4+ T-lymphocytes. The EC₅₀ values for bictegravir were in the range of <0.05 to 6.6 nM. The protein-adjusted EC₉₅ of bictegravir was 361 nM (0.162 micrograms per mL) for wild type HIV-1 virus. Bictegravir displayed antiviral activity in cell culture against HIV-1 groups (M, N, O), including subtypes A, B, C, D, E, F and G (EC₅₀ values ranged from <0.05 and 1.71 nM), and activity against HIV-2 (EC₅₀ = 1.1 nM).

In a study of bictegravir with representatives from the major classes of approved anti-HIV agents (NRTIs [nucleoside reverse transcriptase inhibitors], NNRTIs [non-nucleoside reverse transcriptase inhibitors], INSTIs, and PIs [protease inhibitors]), additive to synergistic antiviral effects were observed. No antagonism was observed for these combinations.

Emtricitabine: The antiviral activity of FTC against laboratory and clinical isolates of HIV-1 was assessed in T lymphoblastoid cell lines, the MAGI-CCR5 cell line, and primary peripheral blood mononuclear cells. The EC₅₀ values for FTC were in the range of 0.0013–0.64 μM.

FTC displayed antiviral activity in cell culture against HIV-1 clades A, B, C, D, E, F, and G (EC₅₀ values ranged from 0.007–0.075 μM) and showed strain specific activity against HIV-2 (EC₅₀ values ranged from 0.007–1.5 μM).

In two-drug combination studies of FTC with NRTIs, NNRTIs, protease inhibitors (PIs), and INSTIs, additive to synergistic effects were observed. No antagonism was observed for these combinations.

Tenofovir Alafenamide: The antiviral activity of TAF against laboratory and clinical isolates of HIV-1 subtype B was assessed in lymphoblastoid cell lines, PBMCs, primary monocyte/macrophage cells and CD4+ T lymphocytes. The EC₅₀ values for TAF ranged from 2.0 to 14.7 nM.

TAF displayed antiviral activity in cell culture against all HIV-1 groups (M, N, O), including subtypes A, B, C, D, E, F, and G (EC₅₀ values ranged from 0.10 to 12.0 nM) and strain specific activity against HIV-2 (EC₅₀ values ranged from 0.91 to 2.63 nM).

In a study of TAF with a broad panel of representatives from the major classes of approved anti-HIV agents (NRTIs, NNRTIs, INSTIs, and PIs), additive to synergistic effects were observed. No antagonism was observed for these combinations.

Resistance

In Cell Culture

Bictegravir: HIV-1 isolates with reduced susceptibility to bictegravir have been selected in cell culture. In one selection, amino acid substitutions M50I and R263K emerged and phenotypic susceptibility to bictegravir was reduced 1.3-, 2.2-, and 2.9-fold for M50I, R263K, and M50I+R263K, respectively. In a second selection, amino acid substitutions T66I and S153F emerged and phenotypic susceptibility to bictegravir was shifted 0.4-, 1.9-, and 0.5-fold for T66I, S153F, and T66I+S153F, respectively.

Emtricitabine: HIV-1 isolates with reduced susceptibility to FTC were selected in cell culture. Reduced susceptibility to FTC was associated with M184V or I substitutions in HIV-1 RT.

Tenofovir Alafenamide: HIV-1 isolates with reduced susceptibility to TAF have been selected in cell culture. HIV-1 isolates selected by TAF expressed a K65R substitution in HIV-1 RT; in addition, a K70E mutation in HIV-1 RT has been transiently observed. HIV-1 isolates with the K65R mutation have low level reduced susceptibility to abacavir, FTC, tenofovir, and lamivudine. *In vitro* drug resistance selection studies with TAF have shown no development of resistance increases above 2.5-fold after 6 months in culture.

In Clinical Trials

In Treatment-Naïve Patients:

No patients receiving BIKTARVY had HIV-1 with treatment emergent genotypic or phenotypic resistance to bictegravir, FTC, or TAF in the final resistance analysis population (n=7 with HIV-1 RNA \geq 200 copies/mL at the time of confirmed virologic failure, Week 48, Week 96 or early study drug discontinuation) in a pooled analysis of 634 antiretroviral-naïve patients through Week 96 (Studies 1489 and 1490).

In Virologically Suppressed Patients:

No patients receiving BIKTARVY had HIV-1 with treatment emergent genotypic or phenotypic resistance to bictegravir, FTC, or TAF in the resistance analysis population (n=2 with HIV-1 RNA \geq 200 copies/mL at the time of confirmed virologic failure, Week 48, or early study drug discontinuation) of 282 virologically-suppressed patients who switched from DTG + ABC/3TC or ABC/DTG/3TC to BIKTARVY (Study 1844).

No patients receiving BIKTARVY had HIV-1 with treatment emergent genotypic or phenotypic resistance to bictegravir, FTC, or TAF in the resistance analysis population (n=1 with HIV-1 RNA \geq 200 copies/mL at the time of confirmed virologic failure, Week 48, or early study drug discontinuation) of 290 virologically-suppressed patients who switched from regimens of ATV or DRV (given with cobicistat or ritonavir), plus either FTC/TDF or ABC/3TC, to BIKTARVY (Study 1878).

Cross-Resistance

Bictegravir:

Integrase Strand Transfer Inhibitor-resistant Mutant HIV-1 Strains: Cross-resistance has been observed among INSTIs. The susceptibility of bictegravir was tested against 64 clinical isolates expressing known INSTI resistance-associated substitutions listed by IAS-USA (20 with single substitutions and 44 with 2 or more substitutions). Isolates with a single INSTI-resistance substitution including E92Q, T97A, Y143C/R, Q148R, and N155H showed less than 2-fold reduced susceptibility to bictegravir. All isolates (n=14) with more than 2.5-fold reduced susceptibility to bictegravir (above the biological cutoff for bictegravir) contained G140A/C/S and Q148H/R/K substitutions; the majority (64.3%, 9/14) had a complex INSTI resistance pattern with an additional INSTI-resistance substitution L74M, T97A, or E138A/K. Of those evaluated isolates containing G140A/C/S and Q148H/R/K substitutions in the absence of additional INSTI-resistance substitutions, 38.5% (5/13) showed more than 2.5-fold reduction. In addition, site-directed mutant viruses with G118R (dolutegravir and raltegravir treatment-emergent substitution) and G118R+T97A had 3.4- and 2.8-fold reduced susceptibility to bictegravir, respectively.

Reverse Transcriptase Inhibitor- and Protease Inhibitor-resistant Strains: bictegravir demonstrated equivalent antiviral activity against 5 NNRTI-resistant, 3 NRTI-resistant, and 4 PI-resistant HIV-1 mutant clones compared with the wild-type strain.

Emtricitabine:

FTC-resistant viruses with the M184V or I substitution were cross-resistant to lamivudine, but retained sensitivity to didanosine, stavudine, tenofovir, and zidovudine.

Viruses harboring substitutions conferring reduced susceptibility to stavudine and zidovudine-thymidine analog substitutions – TAMS (M41L, D67N, K70R, L210W, T215Y/F, K219Q/E) or didanosine (L74V) remained sensitive to FTC. HIV-1 containing the K103N substitution or other substitutions associated with resistance to NNRTIs was susceptible to FTC.

Tenofovir Alafenamide:

Tenofovir resistance substitutions K65R and K70E result in reduced susceptibility to abacavir, didanosine, emtricitabine, lamivudine, and tenofovir, but retain sensitivity to zidovudine.

Multinucleoside resistant HIV-1 with a T69S double insertion mutation or with a Q151M substitution complex including K65R, showed reduced susceptibility to TAF in cell culture.

16 NON-CLINICAL TOXICOLOGY

Bictegravir

Bictegravir was not mutagenic or clastogenic in conventional genotoxicity assays.

Bictegravir was not carcinogenic in a 6-month rasH2 transgenic mouse study at doses of up to 100 and 300 mg/kg/day in males and females [approximately 15 and 23 times the exposure in humans at the recommended human dose], respectively, or in a 2-year rat study at doses of up to 300 mg/kg/day [approximately 31 times the exposure in humans at the recommended human dose].

Emtricitabine

FTC was not mutagenic or clastogenic in conventional genotoxicity assays. Long-term carcinogenicity studies of FTC in rats and mice did not show any carcinogenicity potential.

Tenofovir Alafenamide

Nonclinical studies in rats and dogs revealed bone and kidney as the primary target organs of toxicity.

TAF was not mutagenic or clastogenic in conventional genotoxicity assays.

Because there is a lower tenofovir exposure in rats and mice after TAF administration compared to TDF, carcinogenicity studies were conducted only with TDF. Long-term oral carcinogenicity studies of TDF in mice and rats were carried out at exposures up to approximately 10 times (mice) and 4 times (rats) those observed in humans at the 300 mg therapeutic dose of TDF for HIV-1 infection. At the high dose in female mice, liver adenomas were increased at tenofovir exposures 10 times (300 mg TDF) and 151 times (BIKTARVY) that in humans. In rats, the study was negative for carcinogenic findings at exposures up to 4 times that observed in humans at the therapeutic dose.

17 SUPPORTING PRODUCT MONOGRAPHS

GENVOYA (elvitegravir 150 mg/cobicistat 150 mg/emtricitabine 200 mg/tenofovir alafenamide 10 mg) tablets, Control No. 195789, Product Monograph, Gilead Sciences Canada, Inc. May 24, 2017.

VEMLIDY (tenofovir alafenamide 25 mg) tablets, Control No. 193066, Product Monograph, Gilead Sciences Canada, Inc. May 17, 2017.

READ THIS FOR SAFE AND EFFECTIVE USE OF YOUR MEDICINE
PATIENT MEDICATION INFORMATION

BIKTARVY®
(bictegravir*/emtricitabine/tenofovir alafenamide) tablets**
***as bictegravir sodium **as tenofovir alafenamide hemifumarate**

Read this carefully before you start taking **Biktarvy** and each time you get a refill. This leaflet is a summary and will not tell you everything about this drug. Talk to your healthcare professional about your medical condition and treatment and ask if there is any new information about **Biktarvy**.

Serious Warnings and Precautions

- **You may experience a “Flare-up” of Hepatitis B Virus infection if you also have hepatitis B and stop taking Biktarvy. This may result in your Hepatitis B infection becoming worse than before. Do not stop taking Biktarvy without your doctor’s advice. If you stop taking Biktarvy, tell your doctor immediately about any new, unusual or worsening symptoms that you notice after stopping treatment. After you stop taking Biktarvy, your doctor will still need to check your health and take blood tests regularly to check your liver.**

What is Biktarvy used for?

Biktarvy is a single tablet for the treatment of human immunodeficiency virus 1 (HIV-1) infection in adults and children who weigh at least 25 kg (55 lbs). **Biktarvy** is for people who do not have an HIV virus that is resistant to the components in **Biktarvy**.

How does Biktarvy work?

Biktarvy reduces the amount of HIV in your body and keeps it at a low level. **Biktarvy** also increases the CD4+ (T) cell count in your blood. CD4 cells are white blood cells that are important in helping your body to fight infection.

What are the ingredients in Biktarvy?

Each tablet has the following medicines: bictegravir (as bictegravir sodium), emtricitabine, tenofovir alafenamide (as tenofovir alafenamide hemifumarate)

Each tablet has the following ingredients that are not medicines: croscarmellose sodium, magnesium stearate, microcrystalline cellulose.

Each tablet is covered with the following ingredients that are not medicines: iron oxide black, iron oxide red, polyethylene glycol, polyvinyl alcohol, talc, titanium dioxide.

Biktarvy comes in the following dosage forms:

Biktarvy is available as purplish brown capsule-shaped tablets. Each tablet has 50 mg of bictegravir (equivalent to 52.5 mg of bictegravir sodium), 200 mg of emtricitabine and 25 mg of tenofovir alafenamide (equivalent to 28.0 mg of tenofovir alafenamide hemifumarate).

Do not take Biktarvy if:

- You are allergic to bictegravir, emtricitabine, tenofovir alafenamide or any of the other ingredients of this medicine (Read “What are the ingredients in **Biktarvy**?” above).

- You are currently taking dofetilide* (Tikosyn®)
- You are currently taking rifampin (Rifadin®, Rifamate®, Rifater®, Rimactane®)
- You are currently taking St. John's wort (*Hypericum perforatum*), an herbal remedy used to treat depression and anxiety

*Not available in Canada

To help avoid side effects and ensure proper use, talk to your healthcare professional before you take Biktarvy. Talk about any health conditions or problems you may have, including if you:

- Have liver problems or a history of liver disease, including hepatitis B virus infection (see Serious Warnings and Precautions box and Serious Side Effects table).
- Have kidney problems. Kidney problems, including kidney failure, have occurred in patients taking tenofovir. If you have kidney problems and are taking **Biktarvy** along with certain medicines such as non-steroidal anti-inflammatory drugs, your kidney problems could get worse.
- Have lactic acidosis (high levels of acid in the blood). See the Serious Side Effects table for symptoms and contact your doctor right away if you get these symptoms.

Other warnings you should know about:

If you are pregnant or plan to become pregnant:

It is not known if **Biktarvy** can harm your unborn child. Tell your healthcare provider if you become pregnant while taking **Biktarvy**.

Pregnancy Registry: There is a pregnancy registry for women who take antiviral medicines during pregnancy. This registry collects information about your health and your baby's health. If you become pregnant while taking **Biktarvy**, talk with your doctor about taking part in this registry.

If you are breast-feeding or plan to breast-feed:

Do not breast-feed if you have HIV because of the chance of passing the HIV virus to your baby. One of the ingredients of **Biktarvy**, emtricitabine, can be passed to your baby in your breast milk and may cause harm to your baby. It is not known if the other components can be passed to your baby in breast milk. If you are a woman who has or will have a baby, talk with your doctor about the best way to feed your baby.

Blood Sugar and Fat Levels

Your blood sugar levels (glucose) or levels of fats (lipids) in your blood may increase with HIV treatment. Your doctor may order blood tests for you.

Tell your healthcare professional about all the medicines you take, including any drugs, vitamins, minerals, natural supplements or alternative medicines.

Serious Drug Interactions

Do not take Biktarvy if:

- You are currently taking dofetilide* (Tikosyn®).
- You are currently taking rifampin (Rifadin®, Rifamate®, Rifater®, Rimactane®).
- You are currently taking St. John's wort (*Hypericum perforatum*), an herbal remedy used to treat depression and anxiety.

*Not available in Canada

Drugs that should not be taken with Biktarvy:

- Any other medicines that contain tenofovir (ATRIPLA®, COMPLERA®, DESCOVY®, GENVOYA®, ODEFSEY®, STRIBILD®, Symtuza™, TRUVADA®, VEMLIDY®, VIREAD®).
- Any other medicines that contain emtricitabine or lamivudine (ATRIPLA, COMPLERA, DESCOVY, EMTRIVA®, GENVOYA, ODEFSEY, STRIBILD, Symtuza, TRUVADA, 3TC, Combivir®, Heptovir®, Kivexa®, Triumeq®, Trizivir®).

The following may interact with Biktarvy:

- Medicines used for treating HIV, containing:
 - atazanavir
- Antibiotics, used to treat bacterial infections including tuberculosis, containing:
 - rifabutin or rifapentine
- Anticonvulsants, used to treat epilepsy, such as:
 - carbamazepine, oxcarbazepine, phenobarbital or phenytoin
- Antacids for stomach ulcers, heartburn or acid reflux such as:
 - aluminium/magnesium hydroxide or calcium carbonate
- Mineral supplements and vitamins, containing:
 - calcium or iron
- Ulcer-healing medication, such as:
 - sucralfate

If you are taking an antacid, a mineral supplement or vitamin containing **calcium or iron**, or an **ulcer healing medication**, take it at least 2 hours before or at least 2 hours after **Biktarvy**, or take it with **Biktarvy** together with food.

How to take Biktarvy:

- Always take this medicine exactly as your doctor has told you. Check with your doctor or pharmacist if you are not sure.
- Do not run out of **Biktarvy**. Refill your prescription or talk to your doctor before your **Biktarvy** is all gone.
- Do not stop taking **Biktarvy** without first talking to your doctor.

Usual dose:

Adults and children who weigh at least 25 kg (55 lbs): Take one tablet each day with or without food. Try to take the tablet at the same time each day.

Overdose:

If you think you have taken too much **Biktarvy**, contact your healthcare professional, hospital emergency department or regional poison control centre immediately, even if there are no symptoms.

Missed dose:

It is important not to miss a dose of **Biktarvy**.

- **If you miss a dose of Biktarvy** and you notice **within 18 hours** of the time you usually take **Biktarvy**, take the tablet as soon as you can. Then take the next dose as usual.
- **If you miss a dose of Biktarvy** and you notice **after 18 hours**, wait and take the next dose at your usual time. Do NOT take a double dose (two doses close together).

What are possible side effects from using Biktarvy?

Like all medicines, **Biktarvy** can have side effects. When treating HIV infection, it is not always possible to tell whether some of the undesirable effects that occur are caused by **Biktarvy**, by other medicines you are taking at the same time or by the HIV infection. For this reason it is very important that you inform your doctor about any changes in your health.

Common side effects of **Biktarvy** are:

- Diarrhea.
- Headache.
- Nausea.
- Tiredness.
- Dizziness.
- Trouble sleeping.
- Abnormal dreams.

Less common side effects are indigestion, gas, depression, rash and thoughts of suicide.

Other side effects may include swelling in the face, lips, tongue, or throat (angioedema) and hives (urticaria).

These are not all the possible side effects you may feel when taking **Biktarvy**.

If you experience any side effects not listed here, contact your healthcare professional.

Changes to your immune system (Immune Reconstitution Inflammatory Syndrome) can happen when you start taking HIV-1 medicines. Your immune system may get stronger and begin to fight infections that have been hidden in your body for a long time.

- Autoimmune disorders (when the immune system attacks healthy body tissue) may also occur after you start taking medicines for HIV infection. Examples of this include: Grave's disease (which affects the thyroid gland), Guillain-Barré syndrome (which affects the nervous system), polymyositis (which affects the muscles), or autoimmune hepatitis (which affects the liver). Autoimmune disorders may occur many months after the start of treatment. Look for any other symptoms such as:
 - high temperature (fever), redness, rash or swelling
 - joint or muscle pain

- numbness or weakness beginning in the hands and feet and moving up towards the trunk of the body
- palpitations (chest pain) or rapid heart rate

If you notice these or any symptoms of inflammation or infection, tell your doctor immediately.

Serious side effects and what to do about them			
Symptom / effect	Talk to your healthcare professional		Stop taking drug and get immediate medical help
	Only if severe	In all cases	
<p><u>RARE</u> Effect: Lactic acidosis Symptoms:</p> <ul style="list-style-type: none"> • Feeling very weak or tired • Unusual muscle pain • Stomach pain with nausea and vomiting • Feeling unusually cold, especially in arms and legs • Feeling dizzy or lightheaded • Fast or irregular heartbeat • Fast and deep breathing 		<ul style="list-style-type: none"> ✓ ✓ ✓ ✓ ✓ ✓ ✓ 	
<p><u>VERY RARE</u> Effect: Flare-ups of hepatitis B virus infection following drug discontinuation Symptoms:</p> <ul style="list-style-type: none"> • Jaundice (skin or the white part of eyes turns yellow) • Urine turns dark • Bowel movements (stools) turn light in color • Loss of appetite for several days or longer • Feeling sick to your stomach (nausea) • Lower stomach pain 		<ul style="list-style-type: none"> ✓ ✓ ✓ ✓ ✓ ✓ 	

If you have a troublesome symptom or side effect that is not listed here or becomes bad enough to interfere with your daily activities, talk to your healthcare professional.

Reporting Side Effects

You can report any suspected side effects associated with the use of health products to Health Canada by:

- Visiting the Web page on Adverse Reaction Reporting (<https://www.canada.ca/en/health-canada/services/drugs-health-products/medeffect-canada.html>) for information on how to report online, by mail or by fax; or
- Calling toll-free at 1-866-234-2345.

NOTE: Contact your health professional if you need information about how to manage your side effects. The Canada Vigilance Program does not provide medical advice.

Storage:

- Store **Biktarvy** below 30 °C (86 °F).
- Keep **Biktarvy** in its original container and keep the container tightly closed.
- Do not use **Biktarvy** if the seal over the bottle opening is broken or missing.
- Keep this medicine out of reach and sight of children.
- Do not use this medicine after the expiry date which is stated on the carton and bottle after {EXP}. The expiry date refers to the last day of that month.

If you want more information about Biktarvy:

- Talk to your healthcare professional.
- Find the full product monograph that is prepared for healthcare professionals and includes this Patient Medication Information by visiting the Health Canada website (<https://www.canada.ca/en/health-canada.html>); the manufacturer's website www.gilead.ca, or by calling 1-866-207-4267.

This leaflet was prepared by Gilead Sciences Canada, Inc.

February 28, 2020

Gilead Sciences, Inc.
Foster City, CA 94404
USA

Gilead Sciences Canada, Inc.
Mississauga, ON L5N 2W3

ATRIPLA[®], BIKTARVY[®], COMPLERA[®], DESCOVY[®], EMTRIVA[®], GENVOYA[®], HEPSERA[®], ODEFSEY[®], STRIBILD[®], TRUVADA[®], TYBOST[®], VEMLIDY[®], VIREAD[®] and VITEKTA[®] are trademarks of Gilead Sciences, Inc. or its related companies.

All other marks referenced herein are the property of their respective owners.

© 2020 Gilead Sciences, Inc. All rights reserved.



e203718-GS-002

HIGHLIGHTS OF PRESCRIBING INFORMATION

These highlights do not include all the information needed to use BIKTARVY safely and effectively. See full prescribing information for BIKTARVY.

BIKTARVY® (bictegravir, emtricitabine, and tenofovir alafenamide) tablets, for oral use

Initial U.S. Approval: 2018

WARNING: POST TREATMENT ACUTE EXACERBATION OF HEPATITIS B

See full prescribing information for complete boxed warning.

- Severe acute exacerbations of hepatitis B have been reported in patients who are coinfecting with HIV-1 and HBV and have discontinued products containing emtricitabine (FTC) and/or tenofovir disoproxil fumarate (TDF), and may occur with discontinuation of BIKTARVY. Closely monitor hepatic function in these patients. If appropriate, anti-hepatitis B therapy may be warranted. (5.1)

RECENT MAJOR CHANGES

Indications and Usage (1) 06/2019
Dosage and Administration, Recommended Dosage (2.2) 06/2019
Warnings and Precautions, Immune Reconstitution Syndrome (5.3) 06/2019

INDICATIONS AND USAGE

BIKTARVY is a three-drug combination of bictegravir (BIC), a human immunodeficiency virus type 1 (HIV-1) integrase strand transfer inhibitor (INSTI), and emtricitabine (FTC) and tenofovir alafenamide (TAF), both HIV-1 nucleoside analog reverse transcriptase inhibitors (NRTIs), and is indicated as a complete regimen for the treatment of HIV-1 infection in adults and pediatric patients weighing at least 25 kg who have no antiretroviral treatment history or to replace the current antiretroviral regimen in those who are virologically suppressed (HIV-1 RNA less than 50 copies per mL) on a stable antiretroviral regimen with no history of treatment failure and no known substitutions associated with resistance to the individual components of BIKTARVY. (1)

DOSAGE AND ADMINISTRATION

- Testing: Prior to or when initiating BIKTARVY test for hepatitis B virus infection. Prior to or when initiating BIKTARVY, and during treatment, assess serum creatinine, estimated creatinine clearance, urine glucose, and urine protein in all patients as clinically appropriate. In patients with chronic kidney disease, also assess serum phosphorus. (2.1)
- Recommended dosage: One tablet taken once daily with or without food in patients weighing at least 25 kg. (2.2)
- Renal impairment: BIKTARVY is not recommended in patients with estimated creatinine clearance below 30 mL per minute. (2.3)

- Hepatic impairment: BIKTARVY is not recommended in patients with severe hepatic impairment. (2.4)

DOSAGE FORMS AND STRENGTHS

Tablets: 50 mg of bictegravir (equivalent to 52.5 mg of bictegravir sodium), 200 mg of emtricitabine, and 25 mg of tenofovir alafenamide (equivalent to 28 mg of tenofovir alafenamide fumarate). (3)

CONTRAINDICATIONS

BIKTARVY is contraindicated to be co-administered with:

- dofetilide. (4)
- rifampin. (4)

WARNINGS AND PRECAUTIONS

- Immune reconstitution syndrome: May necessitate further evaluation and treatment. (5.3)
- New onset or worsening renal impairment: Assess serum creatinine, estimated creatinine clearance, urine glucose and urine protein when initiating BIKTARVY and during therapy as clinically appropriate in all patients. Also assess serum phosphorus in patients with chronic kidney disease. (5.4)
- Lactic acidosis/severe hepatomegaly with steatosis: Discontinue treatment in patients who develop symptoms or laboratory findings suggestive of lactic acidosis or pronounced hepatotoxicity. (5.5)

ADVERSE REACTIONS

Most common adverse reactions (incidence greater than or equal to 5%, all grades) are diarrhea, nausea, and headache. (6.1)

To report SUSPECTED ADVERSE REACTIONS, contact Gilead Sciences, Inc. at 1-800-GILEAD-5 or FDA at 1-800-FDA-1088 or www.fda.gov/medwatch.

DRUG INTERACTIONS

- Because BIKTARVY is a complete regimen, coadministration with other antiretroviral medications for the treatment of HIV-1 infection is not recommended. (7.1)
- Consult the Full Prescribing Information prior to and during treatment for important drug interactions. (4, 5.2, 7, 12.3)

USE IN SPECIFIC POPULATIONS

- Lactation: Women infected with HIV should be instructed not to breastfeed due to the potential for HIV transmission. (8.2)
- Pediatrics: Not recommended for patients weighing less than 25 kg. (8.4)

See 17 for PATIENT COUNSELING INFORMATION and FDA-approved patient labeling.

Revised: 08/2019

FULL PRESCRIBING INFORMATION: CONTENTS***WARNING: POST TREATMENT ACUTE EXACERBATION OF HEPATITIS B****1 INDICATIONS AND USAGE****2 DOSAGE AND ADMINISTRATION**

- 2.1 Testing When Initiating and During Treatment with BIKTARVY
- 2.2 Recommended Dosage
- 2.3 Not Recommended in Patients with Severe Renal Impairment
- 2.4 Not Recommended in Patients with Severe Hepatic Impairment

3 DOSAGE FORMS AND STRENGTHS**4 CONTRAINDICATIONS****5 WARNINGS AND PRECAUTIONS**

- 5.1 Severe Acute Exacerbation of Hepatitis B in Patients Coinfected with HIV-1 and HBV
- 5.2 Risk of Adverse Reactions or Loss of Virologic Response Due to Drug Interactions
- 5.3 Immune Reconstitution Syndrome
- 5.4 New Onset or Worsening Renal Impairment
- 5.5 Lactic Acidosis/Severe Hepatomegaly with Steatosis

6 ADVERSE REACTIONS

- 6.1 Clinical Trials Experience
- 6.2 Postmarketing Experience

7 DRUG INTERACTIONS

- 7.1 Other Antiretroviral Medications
- 7.2 Potential for BIKTARVY to Affect Other Drugs
- 7.3 Potential Effect of Other Drugs on One or More Components of BIKTARVY
- 7.4 Drugs Affecting Renal Function
- 7.5 Established and Potentially Significant Drug Interactions
- 7.6 Drugs without Clinically Significant Interactions with BIKTARVY

8 USE IN SPECIFIC POPULATIONS

- 8.1 Pregnancy
- 8.2 Lactation
- 8.4 Pediatric Use
- 8.5 Geriatric Use
- 8.6 Renal Impairment
- 8.7 Hepatic Impairment

10 OVERDOSAGE**11 DESCRIPTION****12 CLINICAL PHARMACOLOGY**

- 12.1 Mechanism of Action
- 12.2 Pharmacodynamics
- 12.3 Pharmacokinetics
- 12.4 Microbiology

13 NONCLINICAL TOXICOLOGY

- 13.1 Carcinogenesis, Mutagenesis, Impairment of Fertility
- 13.2 Animal Toxicology and/or Pharmacology

14 CLINICAL STUDIES

- 14.1 Description of Clinical Trials
- 14.2 Clinical Trial Results in HIV-1 Subjects with No Antiretroviral Treatment History
- 14.3 Clinical Trial Results in HIV-1 Virologically-Suppressed Subjects Who Switched to BIKTARVY
- 14.4 Clinical Trial Results in HIV-1 Infected Pediatric Subjects Between the Ages of 6 to Less than 18 Years

16 HOW SUPPLIED/STORAGE AND HANDLING**17 PATIENT COUNSELING INFORMATION**

*Sections or subsections omitted from the full prescribing information are not listed.

FULL PRESCRIBING INFORMATION

WARNING: POST TREATMENT ACUTE EXACERBATION OF HEPATITIS B

Severe acute exacerbations of hepatitis B have been reported in patients who are coinfecting with HIV-1 and HBV and have discontinued products containing emtricitabine (FTC) and/or tenofovir disoproxil fumarate (TDF), and may occur with discontinuation of BIKTARVY.

Closely monitor hepatic function with both clinical and laboratory follow-up for at least several months in patients who are coinfecting with HIV-1 and HBV and discontinue BIKTARVY. If appropriate, anti-hepatitis B therapy may be warranted [see *Warnings and Precautions (5.1)*].

1 INDICATIONS AND USAGE

BIKTARVY is indicated as a complete regimen for the treatment of human immunodeficiency virus type 1 (HIV-1) infection in adults and pediatric patients weighing at least 25 kg who have no antiretroviral treatment history or to replace the current antiretroviral regimen in those who are virologically-suppressed (HIV-1 RNA less than 50 copies per mL) on a stable antiretroviral regimen with no history of treatment failure and no known substitutions associated with resistance to the individual components of BIKTARVY.

2 DOSAGE AND ADMINISTRATION

2.1 Testing When Initiating and During Treatment with BIKTARVY

Prior to or when initiating BIKTARVY, test patients for hepatitis B virus infection [see *Warnings and Precautions (5.1)*].

Prior to or when initiating BIKTARVY, and during treatment with BIKTARVY, assess serum creatinine, estimated creatinine clearance, urine glucose and urine protein in all patients as clinically appropriate. In patients with chronic kidney disease, also assess serum phosphorus [see *Warnings and Precautions (5.4)*].

2.2 Recommended Dosage

BIKTARVY is a three-drug fixed dose combination product containing 50 mg of bicitgravir (BIC), 200 mg of emtricitabine (FTC), and 25 mg of tenofovir alafenamide (TAF). The recommended dosage of BIKTARVY is one tablet taken orally once daily with or without food in adults and pediatric patients weighing at least 25 kg [see *Clinical Pharmacology (12.3)*].

2.3 Not Recommended in Patients with Severe Renal Impairment

BIKTARVY is not recommended in patients with estimated creatinine clearance below 30 mL per minute [see *Use in Specific Populations (8.6)*].

2.4 Not Recommended in Patients with Severe Hepatic Impairment

BIKTARVY is not recommended in patients with severe hepatic impairment (Child-Pugh Class C) [see *Use in Specific Populations (8.7)* and *Clinical Pharmacology (12.3)*].

3 DOSAGE FORMS AND STRENGTHS

Each BIKTARVY tablet contains 50 mg of bictegravir (BIC) (equivalent to 52.5 mg of bictegravir sodium), 200 mg of emtricitabine (FTC), and 25 mg of tenofovir alafenamide (TAF) (equivalent to 28 mg of tenofovir alafenamide fumarate). The tablets are purplish brown, capsule-shaped, film-coated, and debossed with “GSI” on one side and “9883” on the other side.

4 CONTRAINDICATIONS

BIKTARVY is contraindicated to be co-administered with:

- dofetilide due to the potential for increased dofetilide plasma concentrations and associated serious and/or life-threatening events [see *Drug Interactions (7.5)*].
- rifampin due to decreased BIC plasma concentrations, which may result in the loss of therapeutic effect and development of resistance to BIKTARVY [see *Drug Interactions (7.5)*].

5 WARNINGS AND PRECAUTIONS

5.1 Severe Acute Exacerbation of Hepatitis B in Patients Coinfected with HIV-1 and HBV

Patients with HIV-1 should be tested for the presence of chronic hepatitis B virus (HBV) infection before or when initiating antiretroviral therapy [see *Dosage and Administration (2.1)*].

Severe acute exacerbations of hepatitis B (e.g., liver decompensation and liver failure) have been reported in patients who are coinfecting with HIV-1 and HBV and have discontinued products containing FTC and/or tenofovir disoproxil fumarate (TDF), and may occur with discontinuation of BIKTARVY. Patients coinfecting with HIV-1 and HBV who discontinue BIKTARVY should be closely monitored with both clinical and laboratory follow-up for at least several months after stopping treatment. If appropriate, anti-hepatitis B therapy may be warranted, especially in patients with advanced liver disease or cirrhosis, since post-treatment exacerbation of hepatitis may lead to hepatic decompensation and liver failure.

5.2 Risk of Adverse Reactions or Loss of Virologic Response Due to Drug Interactions

The concomitant use of BIKTARVY with certain other drugs may result in known or potentially significant drug interactions, some of which may lead to [see *Contraindications (4) and Drug Interactions (7.5)*]:

- Loss of therapeutic effect of BIKTARVY and possible development of resistance.
- Possible clinically significant adverse reactions from greater exposures of concomitant drugs.

See Table 3 for steps to prevent or manage these possible and known significant drug interactions, including dosing recommendations. Consider the potential for drug interactions prior to and during BIKTARVY therapy; review concomitant medications during BIKTARVY therapy; and monitor for the adverse reactions associated with the concomitant drugs.

5.3 Immune Reconstitution Syndrome

Immune reconstitution syndrome has been reported in patients treated with combination antiretroviral therapy. During the initial phase of combination antiretroviral treatment, patients whose immune system responds may develop an inflammatory response to indolent or residual opportunistic infections [such as *Mycobacterium avium* infection, cytomegalovirus, *Pneumocystis jirovecii* pneumonia (PCP), or tuberculosis], which may necessitate further evaluation and treatment.

Autoimmune disorders (such as Graves' disease, polymyositis, Guillain-Barré syndrome, and autoimmune hepatitis) have also been reported to occur in the setting of immune reconstitution; however, the time to onset is more variable, and can occur many months after initiation of treatment.

5.4 New Onset or Worsening Renal Impairment

Renal impairment, including cases of acute renal failure and Fanconi syndrome (renal tubular injury with severe hypophosphatemia), has been reported with the use of tenofovir prodrugs in both animal toxicology studies and human trials. In clinical trials of BIKTARVY, there have been no cases of Fanconi syndrome or Proximal Renal Tubulopathy (PRT). In clinical trials of BIKTARVY in subjects with no antiretroviral treatment history with eGFRs greater than 30 mL per minute, and in virologically suppressed subjects switched to BIKTARVY with eGFRs greater than 50 mL per minute, renal serious adverse events were encountered in less than 1% of subjects treated with BIKTARVY through Week 48 [see *Adverse Reactions (6.1)*]. BIKTARVY is not recommended in patients with estimated creatinine clearance below 30 mL per minute.

Patients taking tenofovir prodrugs who have impaired renal function and those taking nephrotoxic agents including non-steroidal anti-inflammatory drugs are at increased risk of developing renal-related adverse reactions.

Prior to or when initiating BIKTARVY, and during treatment with BIKTARVY, assess serum creatinine, estimated creatinine clearance, urine glucose and urine protein in all patients as clinically appropriate. In patients with chronic kidney disease, also assess serum phosphorus. Discontinue BIKTARVY in patients who develop clinically significant decreases in renal function or evidence of Fanconi syndrome.

5.5 Lactic Acidosis/Severe Hepatomegaly with Steatosis

Lactic acidosis and severe hepatomegaly with steatosis, including fatal cases, have been reported with the use of nucleoside analogs, including emtricitabine, a component of BIKTARVY, and tenofovir DF, another prodrug of tenofovir, alone or in combination with other antiretrovirals. Treatment with BIKTARVY should be suspended in any patient who develops clinical or laboratory findings suggestive of lactic acidosis or pronounced hepatotoxicity (which may include hepatomegaly and steatosis even in the absence of marked transaminase elevations).

6 ADVERSE REACTIONS

The following adverse reactions are discussed in other sections of the labeling:

- Severe Acute Exacerbations of Hepatitis B [*see Warnings and Precautions (5.1)*].
- Immune Reconstitution Syndrome [*see Warnings and Precautions (5.3)*].
- New Onset or Worsening Renal Impairment [*see Warnings and Precautions (5.4)*].
- Lactic Acidosis/Severe Hepatomegaly with Steatosis [*see Warnings and Precautions (5.5)*].

6.1 Clinical Trials Experience

Because clinical trials are conducted under widely varying conditions, adverse reaction rates observed in the clinical trials of a drug cannot be directly compared to rates in the clinical trials of another drug and may not reflect the rates observed in practice.

Clinical Trials in Adults with No Antiretroviral Treatment History

The primary safety assessment of BIKTARVY was based on Week 48 data from two randomized, double-blind, active-controlled trials, Trial 1489 and Trial 1490, that enrolled 1274 HIV-1 infected adult subjects with no antiretroviral treatment history. A total of 634 subjects received one tablet of BIKTARVY once daily [*see Clinical Studies (14.2)*].

The most common adverse reactions (all Grades) reported in at least 5% of subjects in the BIKTARVY group in either Trial 1489 or Trial 1490 were diarrhea, nausea, and headache. The proportion of subjects who discontinued treatment with BIKTARVY, abacavir [ABC]/dolutegravir [DTG]/ lamivudine [3TC], or DTG + FTC/TAF, due to adverse events, regardless of severity, was 1%, 1%, and <1%, respectively. Table 1

displays the frequency of adverse reactions (all Grades) greater than or equal to 2% in the BIKTARVY group.

Table 1 Adverse Reactions^a (All Grades) Reported in \geq 2% of HIV-1 Infected Adults with No Antiretroviral Treatment History Receiving BIKTARVY in Trials 1489 or 1490 (Week 48 analysis)

Adverse Reactions	Trial 1489		Trial 1490	
	BIKTARVY N=314	ABC/DTG/3TC N=315	BIKTARVY N=320	DTG + FTC/TAF N=325
Diarrhea	6%	4%	3%	3%
Nausea	5%	17%	3%	5%
Headache	5%	5%	4%	3%
Fatigue	3%	3%	2%	2%
Abnormal dreams	3%	3%	<1%	1%
Dizziness	2%	3%	2%	1%
Insomnia	2%	3%	2%	<1%

a. Frequencies of adverse reactions are based on all adverse events attributed to trial drugs by the investigator. No adverse reactions of Grade 2 or higher occurred in \geq 1% of subjects treated with BIKTARVY.

Additional adverse reactions (all Grades) occurring in less than 2% of subjects administered BIKTARVY in Trials 1489 and 1490 included vomiting, flatulence, dyspepsia, abdominal pain, rash, and depression.

Suicidal ideation, suicide attempt, and depression suicidal occurred in <1% of subjects administered BIKTARVY; all events were serious and primarily occurred in subjects with a preexisting history of depression, prior suicide attempt or psychiatric illness.

The majority (87%) of adverse events associated with BIKTARVY were Grade 1.

Clinical Trials in Virologically Suppressed Adults

The safety of BIKTARVY in virologically-suppressed adults was based on Week 48 data from 282 subjects in a randomized, double-blind, active-controlled trial (Trial 1844) in which virologically-suppressed subjects were switched from either DTG + ABC/3TC or ABC/DTG/3TC to BIKTARVY; and Week 48 data from 290 subjects in an open-label, active-controlled trial in which virologically-suppressed subjects were switched from a regimen containing atazanavir (ATV) (given with cobicistat or ritonavir) or darunavir (DRV) (given with cobicistat or ritonavir) plus either FTC/TDF or ABC/3TC, to BIKTARVY (Trial 1878). Overall, the safety profile in virologically suppressed adult subjects in Trials 1844 and 1878 was similar to that in subjects with no antiretroviral treatment history [see *Clinical Studies (14.3)*].

Laboratory Abnormalities

The frequency of laboratory abnormalities (Grades 3–4) occurring in at least 2% of subjects receiving BIKTARVY in Trials 1489 and 1490 are presented in Table 2.

Table 2 Laboratory Abnormalities (Grades 3–4) Reported in ≥ 2% of Subjects Receiving BIKTARVY in Trials 1489 or 1490 (Week 48 analysis)

Laboratory Parameter Abnormality ^a	Trial 1489		Trial 1490	
	BIKTARVY N=314	ABC/DTG/3TC N=315	BIKTARVY N=320	DTG + FTC/TAF N=325
Amylase (>2.0 x ULN)	2%	2%	2%	2%
ALT (>5.0 x ULN)	1%	1%	2%	1%
AST (>5.0 x ULN)	2%	1%	1%	3%
Creatine Kinase (≥10.0 x ULN)	4%	3%	4%	2%
Neutrophils (<750 mm ³)	2%	3%	2%	1%
LDL-cholesterol (fasted) (>190 mg/dL)	2%	3%	3%	3%

ULN = Upper limit of normal

a. Frequencies are based on treatment-emergent laboratory abnormalities.

Changes in Serum Creatinine: BIC has been shown to increase serum creatinine due to inhibition of tubular secretion of creatinine without affecting renal glomerular function [see *Clinical Pharmacology (12.2)*]. Increases in serum creatinine occurred by Week 4 of treatment and remained stable through Week 48. In Trials 1489 and 1490, median (Q1, Q3) serum creatinine increased by 0.10 (0.03, 0.17) mg per dL from baseline to Week 48 in the BIKTARVY group and was similar to the comparator groups who received ABC/DTG/3TC, or DTG + FTC/TAF. There were no discontinuations due to renal adverse events through Week 48 in BIKTARVY clinical trials.

Changes in Bilirubin: In Trials 1489 and 1490, total bilirubin increases were observed in 12% of subjects administered BIKTARVY through Week 48. Increases were primarily Grade 1 (1.0 to 1.5 x ULN) (9%) and Grade 2 (1.5 to 2.5 x ULN) (3%). Graded bilirubin increases in the ABC/DTG/3TC, and DTG + FTC/TAF groups, were 4% and 6%, respectively. Increases were primarily Grade 1 (3% ABC/DTG/3TC and 5% DTG + FTC/TAF) or Grade 2 (1% ABC/DTG/3TC and 1% DTG + FTC/TAF). There were no discontinuations due to hepatic adverse events through Week 48 in BIKTARVY clinical studies.

Clinical Trials in Pediatric Subjects

The safety of BIKTARVY was evaluated in HIV-1 infected virologically-suppressed subjects between the ages of 12 to less than 18 years and weighing at least 35 kg (N=50) through Week 48 (cohort 1), and in virologically-suppressed subjects between the ages of 6 to less than 12 years and weighing at least 25 kg (N=50) through Week 24 (cohort 2) in an open label clinical trial (Trial 1474) [see *Clinical Studies (14.4)*]. No new adverse reactions or laboratory abnormalities were identified compared to those

observed in adults. Adverse reactions were reported in 10% of pediatric subjects. The majority (85%) of adverse reactions were Grade 1. No Grade 3 or 4 adverse reactions were reported. The adverse reaction reported by more than one subject (regardless of severity) was abdominal pain (n=2). One subject (1%) had Grade 2 adverse reactions of insomnia and anxiety that led to discontinuation of BIKTARVY. The other adverse reactions that occurred in single subjects were similar to those seen in adults.

6.2 Postmarketing Experience

The following events have been identified during post approval use of products containing TAF. Because these events are reported voluntarily from a population of uncertain size, it is not always possible to reliably estimate their frequency or establish a causal relationship to drug exposure.

Skin and Subcutaneous Tissue Disorders

Angioedema and urticaria

7 DRUG INTERACTIONS

7.1 Other Antiretroviral Medications

Because BIKTARVY is a complete regimen, coadministration with other antiretroviral medications for the treatment of HIV-1 infection is not recommended [see *Indications and Usage (1)*]. Comprehensive information regarding potential drug-drug interactions with other antiretroviral medications is not provided because the safety and efficacy of concomitant HIV-1 antiretroviral therapy is unknown.

7.2 Potential for BIKTARVY to Affect Other Drugs

BIC inhibits organic cation transporter 2 (OCT2) and multidrug and toxin extrusion transporter 1 (MATE1) *in vitro*. Coadministration of BIKTARVY with drugs that are substrates of OCT2 and MATE1 (e.g., dofetilide) may increase their plasma concentrations (see Table 3).

7.3 Potential Effect of Other Drugs on One or More Components of BIKTARVY

BIC is a substrate of CYP3A and UGT1A1. A drug that is a strong inducer of CYP3A and also an inducer of UGT1A1 can substantially decrease the plasma concentrations of BIC which may lead to loss of therapeutic effect of BIKTARVY and development of resistance [see *Clinical Pharmacology (12.3)*].

The use of BIKTARVY with a drug that is a strong inhibitor of CYP3A and also an inhibitor of UGT1A1 may significantly increase the plasma concentrations of BIC.

TAF is a substrate of P-glycoprotein (P-gp) and breast cancer resistance protein (BCRP). Co-administration of drugs that inhibit P-gp and BCRP may increase the absorption and plasma concentrations of TAF [see *Clinical Pharmacology (12.3)*]. Co-administration of drugs that induce P-gp activity are expected to decrease the

absorption of TAF, resulting in decreased plasma concentration of TAF, which may lead to loss of therapeutic effect of BIKTARVY and development of resistance (see Table 3).

7.4 Drugs Affecting Renal Function

Because FTC and tenofovir are primarily excreted by the kidneys by a combination of glomerular filtration and active tubular secretion, coadministration of BIKTARVY with drugs that reduce renal function or compete for active tubular secretion may increase concentrations of FTC, tenofovir, and other renally eliminated drugs and this may increase the risk of adverse reactions. Some examples of drugs that are eliminated by active tubular secretion include, but are not limited to, acyclovir, cidofovir, ganciclovir, valacyclovir, valganciclovir, aminoglycosides (e.g., gentamicin), and high-dose or multiple NSAIDs [see *Warnings and Precautions (5.4)*].

7.5 Established and Potentially Significant Drug Interactions

Table 3 provides a listing of established or potentially clinically significant drug interactions with recommended prevention or management strategies. The drug interactions described are based on studies conducted with either BIKTARVY, the components of BIKTARVY (BIC, FTC, and TAF) as individual agents, or are drug interactions that may occur with BIKTARVY [see *Contraindications (4)*, *Warnings and Precautions (5.2)*, and *Clinical Pharmacology (12.3)*].

Table 3 Established and Potentially Significant^a Drug Interactions: Alteration in Regimen May be Recommended

Concomitant Drug Class: Drug Name	Effect on Concentration^b	Clinical Comment
Antiarrhythmics: dofetilide	↑ Dofetilide	Coadministration is contraindicated due to the potential for serious and/or life-threatening events associated with dofetilide therapy [see <i>Contraindications (4)</i>].
Anticonvulsants: carbamazepine ^c oxcarbazepine phenobarbital phenytoin	↓ BIC ↓ TAF	Coadministration with alternative anticonvulsants should be considered.
Antimycobacterials: rifabutin ^c rifampin ^{c,d} rifapentine	↓ BIC ↓ TAF	Coadministration with rifampin is contraindicated due to the effect of rifampin on the BIC component of BIKTARVY [see <i>Contraindications (4)</i>]. Coadministration with rifabutin or rifapentine is not recommended.
Herbal Products: St. John's wort ^e	↓ BIC ↓ TAF	Coadministration with St. John's wort is not recommended.
Medications or oral supplements containing polyvalent cations (e.g., Mg, Al, Ca, Fe): Calcium or iron supplements ^c Cation-containing antacids or laxatives ^c Sucralfate Buffered medications	↓ BIC	<u>Antacids containing Al/Mg:</u> BIKTARVY can be taken at least <u>2 hours before</u> or <u>6 hours after</u> taking antacids containing Al/Mg. Routine administration of BIKTARVY together with, or 2 hours after, antacids containing Al/Mg is not recommended. <u>Supplements or Antacids containing Calcium or Iron:</u> BIKTARVY and supplements or antacids containing calcium or iron can be taken together with food. Routine administration of BIKTARVY under fasting conditions together with, or 2 hours after, supplements or antacids containing calcium or iron is not recommended.
Metformin	↑ Metformin	Refer to the prescribing information of metformin for assessing the benefit and risk of concomitant use of BIKTARVY and metformin.

- Table is not all inclusive.
- ↑ = Increase, ↓ = Decrease.
- Drug-drug interaction study was conducted with either BIKTARVY or its components as individual agents.
- Strong inducer of CYP3A and P-gp, and inducer of UGT1A1.
- The induction potency of St. John's wort may vary widely based on preparation.

7.6 Drugs without Clinically Significant Interactions with BIKTARVY

Based on drug interaction studies conducted with BIKTARVY or the components of BIKTARVY, no clinically significant drug interactions have been observed when BIKTARVY is combined with the following drugs: ethinyl estradiol, ledipasvir/sofosbuvir,

midazolam, norgestimate, sertraline, sofosbuvir, sofosbuvir/velpatasvir, and sofosbuvir/velpatasvir/voxilaprevir.

8 USE IN SPECIFIC POPULATIONS

8.1 Pregnancy

Pregnancy Exposure Registry

There is a pregnancy exposure registry that monitors pregnancy outcomes in women exposed to BIKTARVY during pregnancy. Healthcare providers are encouraged to register patients by calling the Antiretroviral Pregnancy Registry (APR) at 1-800-258-4263.

Risk Summary

There are insufficient human data on the use of BIKTARVY during pregnancy to inform a drug-associated risk of birth defects and miscarriage. Dolutegravir, another integrase inhibitor, has been associated with neural tube defects (NTDs) (*see Data*). Discuss the benefit-risk of using BIKTARVY with individuals of childbearing potential, particularly if pregnancy is being planned. Bictegravir (BIC) and tenofovir alafenamide (TAF) use in women during pregnancy has not been evaluated; however, emtricitabine (FTC) use during pregnancy has been evaluated in a limited number of women reported to the APR. Available data from the APR show no difference in the overall risk of major birth defects for FTC compared with the background rate for major birth defects of 2.7% in a U.S. reference population of the Metropolitan Atlanta Congenital Defects Program (MACDP) (*see Data*). The rate of miscarriage is not reported in the APR. The estimated background rate of miscarriage in the clinically recognized pregnancies in the U.S. general population is 15-20%. Methodological limitations of the APR include the use of MACDP as the external comparator group. The MACDP population is not disease-specific, evaluates women and infants from a limited geographic area, and does not include outcomes for births that occurred at less than 20 weeks gestation.

In animal reproduction studies, no evidence of adverse developmental outcomes was observed with the components of BIKTARVY at exposures that were either not maternally toxic (rabbits) or greater than (rats and mice) those in humans at the recommended human dose (RHD) (*see Data*). During organogenesis, systemic exposures (AUC) to BIC were approximately 36 (rats) and 0.6 times (rabbits), to FTC were approximately 60 (mice) and 108 times (rabbits), and to TAF were approximately 2 (rats) and 78 times (rabbits) the exposure at the RHD of BIKTARVY. In rat pre/postnatal development studies, maternal systemic exposures (AUC) were 30 times (BIC), 60 times (FTC), and 19 times (TDF) the exposures of each component in humans at the RHD.

Data

Human Data

Bictegravir: Data from an observational study in Botswana showed that dolutegravir, another integrase inhibitor, was associated with increased risk of neural tube defects when administered at the time of conception and in early pregnancy. Data available to date from other sources including the APR, clinical trials, and postmarketing data are insufficient to address this risk with BIC.

Emtricitabine: Based on prospective reports to the APR of 3,406 exposures to FTC-containing regimens during pregnancy resulting in live births (including 2,326 exposed in the first trimester and 1,080 exposed in the second/third trimester), there was no difference between FTC and overall birth defects compared with the background birth defect rate of 2.7% in the U.S. reference population of the MACDP. The prevalence of birth defects in live births was 2.3% (95% CI: 1.7% to 3.0%) with first trimester exposure to FTC-containing regimens and 2.0% (95% CI: 1.3% to 3.1%) with the second/third trimester exposure to FTC-containing regimens.

Animal Data

Bictegravir: BIC was administered orally to pregnant rats (5, 30, or 300 mg/kg/day) and rabbits (100, 300, or 1000 mg/kg/day) on gestation days 7 through 17, and 7 through 19, respectively. No adverse embryo-fetal effects were observed in rats and rabbits at BIC exposures (AUC) of up to approximately 36 (rats) and 0.6 (rabbits) times the exposure in humans at the RHD of BIKTARVY. Spontaneous abortion, increased clinical signs [fecal changes, thin body, and cold-to-touch], and decreased body weight were observed at a maternally toxic dose in rabbits (1000 mg/kg/day; approximately 1.4 times higher than human exposure at the RHD).

In a pre/postnatal development study, BIC was administered orally to pregnant rats (up to 300 mg/kg/day) from gestation days 6 to lactation/post-partum day 24. No significant adverse effects were observed in the offspring exposed daily from before birth (*in utero*) through lactation at maternal and pup exposures (AUC) of approximately 30 and 11 times higher, respectively, than human exposures at the RHD.

Emtricitabine: FTC was administered orally to pregnant mice (250, 500, or 1000 mg/kg/day) and rabbits (100, 300, or 1000 mg/kg/day) through organogenesis (on gestation days 6 through 15, and 7 through 19, respectively). No significant toxicological effects were observed in embryo-fetal toxicity studies performed with emtricitabine in mice at exposures approximately 60 times higher and in rabbits at approximately 108 times higher than human exposures at the RHD.

In a pre/postnatal development study with FTC, mice were administered doses up to 1000 mg/kg/day; no significant adverse effects directly related to drug were observed in the offspring exposed daily from before birth (*in utero*) through sexual maturity at daily exposures (AUC) of approximately 60 times higher than human exposures at the RHD.

Tenofovir alafenamide: TAF was administered orally to pregnant rats (25, 100, or 250 mg/kg/day) and rabbits (10, 30, or 100 mg/kg/day) through organogenesis (on gestation days 6 through 17, and 7 through 20, respectively). No adverse embryo-fetal effects were observed in rats and rabbits at TAF exposures of approximately 2 (rats) and 78 (rabbits) times higher than the exposure in humans at the recommended daily dose of BIKTARVY. TAF is rapidly converted to tenofovir; the observed tenofovir exposure in rats and rabbits were 55 (rats) and 86 (rabbits) times higher than human tenofovir exposures at the RHD. Since TAF is rapidly converted to tenofovir and lower tenofovir exposures in rats and mice were observed after TAF administration compared to TDF administration, a pre/postnatal development study in rats was conducted only with TDF. Doses up to 600 mg/kg/day were administered through lactation; no adverse effects were observed in the offspring on gestation day 7 [and lactation day 20] at tenofovir exposures of approximately 12 [19] times higher than the exposures in humans at the RHD of BIKTARVY.

8.2 Lactation

Risk Summary

The Centers for Disease Control and Prevention recommend that HIV-1-infected mothers in the United States not breastfeed their infants to avoid risking postnatal transmission of HIV-1 infection.

It is not known whether BIKTARVY or all of the components of BIKTARVY are present in human breast milk, affects human milk production, or has effects on the breastfed infant. Based on published data, FTC has been shown to be present in human breast milk. BIC was detected in the plasma of nursing rat pups likely due to the presence of BIC in milk, and tenofovir has been shown to be present in the milk of lactating rats and rhesus monkeys after administration of TDF (*see Data*). It is unknown if TAF is present in animal milk.

Because of the potential for 1) HIV transmission (in HIV-negative infants); 2) developing viral resistance (in HIV-positive infants); and 3) adverse reactions in a breastfed infant similar to those seen in adults, instruct mothers not to breastfeed if they are receiving BIKTARVY.

Data

Animal Data

Bictegravir: BIC was detected in the plasma of nursing rat pups in the pre/postnatal development study (post-natal day 10), likely due to the presence of BIC in milk.

Tenofovir alafenamide: Studies in rats and monkeys have demonstrated that tenofovir is secreted in milk. Tenofovir was excreted into the milk of lactating rats following oral administration of TDF (up to 600 mg/kg/day) at up to approximately 24% of the median plasma concentration in the highest dosed animals at lactation day 11. Tenofovir was excreted into the milk of lactating monkeys following a single

subcutaneous (30 mg/kg) dose of tenofovir at concentrations up to approximately 4% of plasma concentration, resulting in exposure (AUC) of approximately 20% of plasma exposure.

8.4 Pediatric Use

The safety and effectiveness of BIKTARVY for the treatment of HIV-1 infection was established in pediatric patients with body weight greater than or equal to 25 kg [see *Indications and Usage (1) and Dosage and Administration (2.2)*].

Use of BIKTARVY in pediatric patients between the ages of 6 to less than 18 years and weighing at least 25 kg is supported by trials in adults and by an open-label trial in virologically-suppressed pediatric subjects aged 12 to less than 18 years and weighing at least 35 kg receiving BIKTARVY through Week 48 (cohort 1 of Trial 1474, N=50) and in virologically-suppressed pediatric subjects aged 6 to less than 12 years and weighing at least 25 kg receiving BIKTARVY through Week 24 (cohort 2 of Trial 1474, N=50). The safety and efficacy of BIKTARVY in these pediatric subjects was similar to that in adults, and there was no clinically significant change in exposure for the components of BIKTARVY [see *Adverse Reactions (6.1), Clinical Pharmacology (12.3), and Clinical Studies (14.4)*].

Safety and effectiveness of BIKTARVY in pediatric patients weighing less than 25 kg have not been established.

8.5 Geriatric Use

Clinical trials of BIKTARVY did not include sufficient numbers of subjects aged 65 and over to determine whether they respond differently from younger subjects.

8.6 Renal Impairment

BIKTARVY is not recommended in patients with severe renal impairment (estimated creatinine clearance (CL_{cr}) below 30 mL per minute, estimated by Cockcroft-Gault (C-G). No dosage adjustment of BIKTARVY is recommended in patients with CL_{cr} greater than or equal to 30 mL per minute [see *Dosage and Administration (2.3)*].

8.7 Hepatic Impairment

No dosage adjustment of BIKTARVY is recommended in patients with mild (Child-Pugh Class A) or moderate (Child-Pugh Class B) hepatic impairment. BIKTARVY has not been studied in patients with severe hepatic impairment (Child-Pugh Class C). Therefore, BIKTARVY is not recommended for use in patients with severe hepatic impairment [see *Dosage and Administration (2.4) and Clinical Pharmacology (12.3)*].

10 OVERDOSAGE

No data are available on overdose of BIKTARVY in patients. If overdose occurs, monitor the patient for evidence of toxicity. Treatment of overdose with BIKTARVY

consists of general supportive measures including monitoring of vital signs as well as observation of the clinical status of the patient.

Hemodialysis treatment removes approximately 30% of the FTC dose over a 3-hour dialysis period starting within 1.5 hours of FTC dosing (blood flow rate of 400 mL per minute and a dialysate flow rate of 600 mL per minute). It is not known whether FTC can be removed by peritoneal dialysis.

Tenofovir is efficiently removed by hemodialysis with an extraction coefficient of approximately 54%.

11 DESCRIPTION

BIKTARVY (bictegravir, emtricitabine, and tenofovir alafenamide) is a fixed dose combination tablet containing bictegravir (BIC), emtricitabine (FTC), and tenofovir alafenamide (TAF) for oral administration.

- BIC is an integrase strand transfer inhibitor (INSTI).
- FTC, a synthetic nucleoside analog of cytidine, is an HIV nucleoside analog reverse transcriptase inhibitor (HIV NRTI).
- TAF, an HIV NRTI, is converted *in vivo* to tenofovir, an acyclic nucleoside phosphonate (nucleotide) analog of adenosine 5'-monophosphate.

Each tablet contains 50 mg of BIC (equivalent to 52.5 mg of bictegravir sodium), 200 mg of FTC, and 25 mg of TAF (equivalent to 28 mg of tenofovir alafenamide fumarate) and the following inactive ingredients: croscarmellose sodium, magnesium stearate, and microcrystalline cellulose. The tablets are film-coated with a coating material containing iron oxide black, iron oxide red, polyethylene glycol, polyvinyl alcohol, talc, and titanium dioxide.

Bictegravir: The chemical name of bictegravir sodium is 2,5-Methanopyrido[1',2':4,5]pyrazino[2,1-*b*][1,3]oxazepine-10-carboxamide, 2,3,4,5,7,9,13,13a-octahydro-8-hydroxy-7,9-dioxo-*N*-[(2,4,6-trifluorophenyl)methyl]-, sodium salt (1:1), (2*R*,5*S*,13*aR*)-.

Bictegravir sodium has a molecular formula of C₂₁H₁₇F₃N₃NaO₅ and a molecular weight of 471.4 and has the following structural formula:

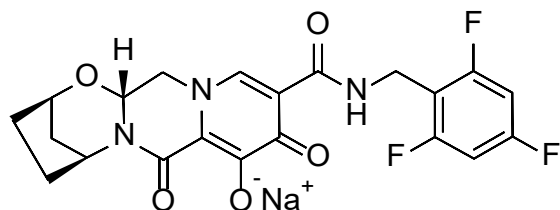

Bictegravir sodium is an off-white to yellow solid with a solubility of 0.1 mg per mL in water at 20 °C.

Emtricitabine: The chemical name of FTC is 4-amino-5-fluoro-1-(2*R*-hydroxymethyl-1,3-oxathiolan-5*S*-yl)-(1*H*)-pyrimidin-2-one. FTC is the (-)-enantiomer of a thio analog of cytidine, which differs from other cytidine analogs in that it has a fluorine in the 5 position.

FTC has a molecular formula of C₈H₁₀FN₃O₃S and a molecular weight of 247.2 and has the following structural formula:

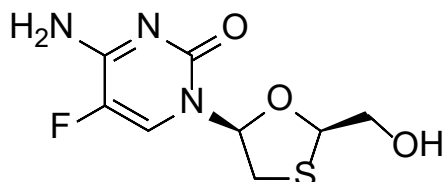

FTC is a white to off-white powder with a solubility of approximately 112 mg per mL in water at 25 °C.

Tenofovir alafenamide: The chemical name of tenofovir alafenamide fumarate drug substance is L-alanine, *N*-[(*S*)-[[(*1R*)-2-(6-amino-9*H*-purin-9-yl)-1-methylethoxy]methyl]phenoxyphosphinyl]-, 1-methylethyl ester, (*2E*)-2-butenedioate (2:1).

Tenofovir alafenamide fumarate has an empirical formula of C₂₁H₂₉O₅N₆P•½(C₄H₄O₄) and a formula weight of 534.5 and has the following structural formula:

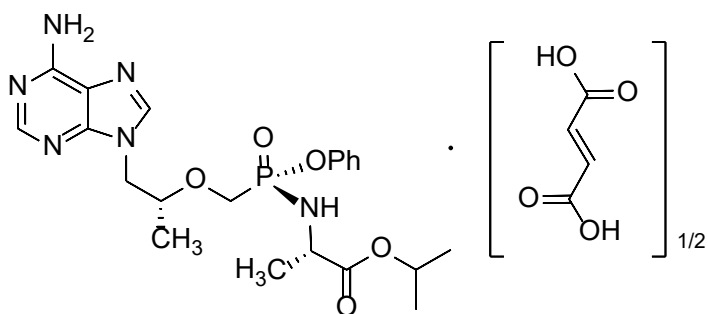

Tenofovir alafenamide fumarate is a white to off-white or tan powder with a solubility of 4.7 mg per mL in water at 20 °C.

12 CLINICAL PHARMACOLOGY

12.1 Mechanism of Action

BIKTARVY is a fixed dose combination of antiretroviral drugs bicitgravir (BIC), emtricitabine (FTC), and tenofovir alafenamide (TAF) [see *Microbiology* (12.4)].

12.2 Pharmacodynamics

Cardiac Electrophysiology

In a thorough QT/QTc trial in 48 healthy subjects, BIC at doses 1.5 and 6 times the recommended dose did not affect the QT/QTc interval and did not prolong the PR interval. In a thorough QT/QTc trial in 48 healthy subjects, TAF at the recommended dose or at a dose 5 times the recommended dose, did not affect the QT/QTc interval and did not prolong the PR interval. The effect of FTC on the QT interval is not known.

Effects on Serum Creatinine

Mean change from baseline in serum creatinine in healthy subjects who received BIC 75 mg (1.5 times the approved recommended dosage) once daily with food for 14 days was 0.1 mg per dL on Days 7 and 14 compared to placebo. BIC did not have a significant effect on the estimated creatinine clearance or on the actual glomerular filtration rate (determined by the clearance of probe drug, iohexol).

12.3 Pharmacokinetics

The pharmacokinetic (PK) properties of BIKTARVY components are provided in Table 4. The multiple dose PK parameters of BIKTARVY components (based on population pharmacokinetic analysis) are provided in Table 5.

Table 4 Pharmacokinetic Properties of the Components of BIKTARVY

		Bictegravir (BIC)	Emtricitabine (FTC)	Tenofovir Alafenamide (TAF)
Absorption				
T_{max} (h) ^a		2.0–4.0	1.5–2.0	0.5–2.0
Effect of high-fat meal (relative to fasting) ^b	AUC ratio	1.24 (1.16, 1.33)	0.96 (0.93, 0.99)	1.63 (1.43, 1.85)
	C_{max} ratio	1.13 (1.06, 1.20)	0.86 (0.78, 0.93)	0.92 (0.73, 1.14)
Distribution				
% bound to human plasma proteins		>99	<4	~80
Blood-to-plasma ratio		0.64	0.6	1.0
Elimination				
$t_{1/2}$ (h) ^c		17.3 (14.8, 20.7)	10.4 (9.0, 12.0)	0.51 (0.45, 0.62) ^c
Metabolism				
Metabolic pathway(s)		CYP3A UGT1A1	Not significantly metabolized	Cathepsin A ^d (PBMCs) CES1 (hepatocytes)
Excretion				
Major route of elimination		Metabolism	Glomerular filtration and active tubular secretion	Metabolism
% of dose excreted in urine ^e		35	70	<1
% of dose excreted in feces ^e		60.3	13.7	31.7

PBMCs=peripheral blood mononuclear cells; CES1=carboxylesterase 1

- Values reflect administration of BIKTARVY with or without food.
- Values refer to geometric mean ratio [high-fat meal/ fasting] in PK parameters and (90% confidence interval). High fat meal is approximately 800 kcal, 50% fat.
- $t_{1/2}$ values refer to median (Q1, Q3) terminal plasma half-life. Note that the active metabolite of TAF, tenofovir diphosphate, has a half-life of 150-180 hours within PBMCs.
- In vivo*, TAF is hydrolyzed within cells to form tenofovir (major metabolite), which is phosphorylated to the active metabolite, tenofovir diphosphate. *In vitro* studies have shown that TAF is metabolized to tenofovir by cathepsin A in PBMCs and macrophages; and by CES1 in hepatocytes.
- Dosing in mass balance studies: single dose administration of [¹⁴C] BIC; single dose administration of [¹⁴C] FTC after multiple dosing of FTC for ten days; single dose administration of [¹⁴C] TAF.

Table 5 Multiple Dose PK Parameters of BIC, FTC, and TAF Following Oral Administration of BIKTARVY in HIV-Infected Adults

Parameter Mean (CV%)	Bictegravir	Emtricitabine	Tenofovir Alafenamide
C _{max} (microgram per mL)	6.15 (22.9)	2.13 (34.7)	0.121 (15.4)
AUC _{tau} (microgram•h per mL)	102 (26.9)	12.3 (29.2)	0.142 (17.3)
C _{trough} (microgram per mL)	2.61 (35.2)	0.096 (37.4)	NA

CV=Coefficient of Variation; NA=Not Applicable

Specific Populations

Patients with Renal Impairment

No clinically relevant differences in the pharmacokinetics of BIC, TAF, or its metabolite tenofovir were observed between subjects with severe renal impairment (CL_{cr} 15 to 29 mL per minute estimated by Cockcroft-Gault method) and healthy subjects.

Patients with Hepatic Impairment

Bictegravir: Clinically relevant changes in the pharmacokinetics of BIC were not observed in subjects with moderate (Child-Pugh Class B) hepatic impairment.

Emtricitabine: The pharmacokinetics of FTC has not been studied in subjects with hepatic impairment; however, FTC is not significantly metabolized by liver enzymes, so the impact of hepatic impairment should be limited.

Tenofovir Alafenamide: Clinically relevant changes in the pharmacokinetics of TAF or its metabolite tenofovir were not observed in subjects with mild or moderate (Child-Pugh Class A and B) hepatic impairment [see *Use in Specific Populations (8.7)*].

Hepatitis B and/or Hepatitis C Virus Coinfection

The pharmacokinetics of BIC, FTC, and TAF have not been evaluated in subjects coinfecting with hepatitis B and/or C virus.

Geriatric Patients

The pharmacokinetics of BIC, FTC, and TAF have not been fully evaluated in the elderly (65 years of age and older). Population pharmacokinetics analysis of HIV-infected subjects in Phase 3 trials of BIKTARVY showed that age did not have a clinically relevant effect on exposures of BIC and TAF up to 74 years of age [see *Use in Specific Populations (8.5)*].

Pediatric Patients

Mean BIC C_{trough} was lower in 50 pediatric patients aged 12 to less than 18 years and weighing at least 35 kg who received BIKTARVY in Trial 1474 relative to adults following administration of BIKTARVY, but was not considered clinically significant based on exposure-response relationships; exposures of FTC and TAF in these pediatric patients were similar to those in adults (Table 6).

Table 6 Multiple Dose PK Parameters of BIC, FTC, and TAF Following Oral Administration of BIKTARVY in HIV-Infected Pediatric Subjects Aged 12 to less than 18 years

Parameter Mean (CV%)	Bictegravir ^a	Emtricitabine ^b	Tenofovir Alafenamide ^a
C_{max} (microgram per mL)	6.24 (27.1)	2.69 (34.0)	0.133 (70.2)
AUC_{tau} (microgram·h per mL)	89.1 (31.0)	13.6 (21.7)	0.196 (50.3)
C_{trough} (microgram per mL)	1.78 (44.4)	0.064 (25.0)	NA

CV=Coefficient of Variation; NA=Not Applicable

- From Population PK analysis of cohort 1 of Trial 1474 (n=50 for BIC; n=49 for TAF).
- From Intensive PK analysis of cohort 1 of Trial 1474 (n=24).

Mean BIC C_{max} , and exposures of FTC and TAF (AUC_{tau} and C_{max}) achieved in 50 pediatric patients between the ages of 6 to less than 12 years and weighing at least 25 kg who received BIKTARVY in Trial 1474 were higher than exposures in adults; however, the increase was not considered clinically significant as the safety profiles were similar in adult and pediatric patients (Table 7) [see *Use in Specific Populations* (8.4)].

Table 7 Multiple Dose PK Parameters of BIC, FTC, and TAF Following Oral Administration of BIKTARVY in HIV-Infected Pediatric Subjects Aged 6 to less than 12 years

Parameter Mean (CV%)	Bictegravir ^a	Emtricitabine ^b	Tenofovir Alafenamide ^a
C _{max} (microgram per mL)	9.46 (24.3)	3.89 (31.0)	0.205 (44.6)
AUC _{tau} (microgram•h per mL)	128 (27.8)	17.6 (36.9)	0.278 (40.3)
C _{trough} (microgram per mL)	2.36 (39.0)	0.227 (323)	NA

CV=Coefficient of Variation; NA=Not Applicable

- a. From Population PK analysis of cohort 2 of Trial 1474 (n=50 for BIC; n=47 for TAF).
b. From Intensive PK analysis of cohort 2 of Trial 1474 (n=25 except n=24 for C_{trough}).

Race and Gender

No clinically relevant changes in the pharmacokinetics of BIC, FTC, and TAF were observed based on gender or race.

Drug Interaction Studies

As BIKTARVY is a complete regimen for the treatment of HIV-1 infection, comprehensive information regarding potential drug-drug interactions with other antiretroviral agents is not provided.

BIC is a substrate of CYP3A and UGT1A1.

BIC is an inhibitor of OCT2 and MATE1. At clinically relevant concentrations, BIC is not an inhibitor of hepatic transporters OATP1B1, OATP1B3, OCT1, BSEP, renal transporters OAT1 and OAT3, or CYP (including CYP3A) or UGT1A1 enzymes.

TAF is a substrate of P-gp and BCRP.

At clinically relevant concentrations, TAF is not an inhibitor of drug transporters P-gp, BCRP, hepatic transporters OATP1B1, OATP1B3, OCT1, BSEP, renal transporters OAT1, OAT3, OCT2, MATE1, or CYP (including CYP3A) or UGT1A1 enzymes.

Drug interaction studies were conducted with BIKTARVY or its components. Tables 8 and 9 summarize the pharmacokinetic effects of other drugs on BIC and TAF, respectively. Table 10 summarizes the pharmacokinetic effects of BIKTARVY or its components on other drugs.

Effect of Other Drugs on BIKTARVY Components

Table 8 Effect of Other Drugs on BIC^a

Coadministered Drug	Dose of Coadministered Drug (mg)	BIC (mg)	Mean Ratio of BIC Pharmacokinetic Parameters (90% CI); No effect = 1.00		
			C _{max}	AUC	C _{min}
Ledipasvir/ Sofosbuvir (fed)	90/400 once daily	75 once daily	0.98 (0.94, 1.03)	1.00 (0.97, 1.03)	1.04 (0.99, 1.09)
Rifabutin (fasted)	300 once daily	75 once daily	0.80 (0.67, 0.97)	0.62 (0.53, 0.72)	0.44 (0.37, 0.52)
Rifampin (fed)	600 once daily	75 single dose	0.72 (0.67, 0.78)	0.25 (0.22, 0.27)	NA
Sofosbuvir/ velpatasvir/ voxilaprevir (fed)	400/100/100+100 voxilaprevir ^b once daily	50 once daily	0.98 (0.94, 1.01)	1.07 (1.03, 1.10)	1.10 (1.05, 1.17)
Voriconazole (fasted)	300 twice daily	75 single dose	1.09 (0.96, 1.23)	1.61 (1.41, 1.84)	NA
Maximum strength antacid (simultaneous administration, fasted)	20 mL ^c single dose (oral)	50 single dose	0.20 (0.16, 0.24)	0.21 (0.18, 0.26)	NA
Maximum strength antacid (2 h after BIKTARVY fasted)	20 mL ^c single dose (oral)	50 single dose	0.93 (0.88, 1.00)	0.87 (0.81, 0.93)	NA
Maximum strength antacid (2 h before BIKTARVY fasted)	20 mL ^c single dose (oral)	50 single dose	0.42 (0.33, 0.52)	0.48 (0.38, 0.59)	NA
Maximum strength antacid (simultaneous administration, fed ^d)	20 mL ^c single dose (oral)	50 single dose	0.51 (0.43, 0.62)	0.53 (0.44, 0.64)	NA

Coadministered Drug	Dose of Coadministered Drug (mg)	BIC (mg)	Mean Ratio of BIC Pharmacokinetic Parameters (90% CI); No effect = 1.00		
			C _{max}	AUC	C _{min}
Calcium carbonate (simultaneous administration, fasted)	1200 single dose	50 single dose	0.58 (0.51, 0.67)	0.67 (0.57, 0.78)	NA
Calcium carbonate (simultaneous administration, fed ^d)	1200 single dose	50 single dose	0.90 (0.78, 1.03)	1.03 (0.89, 1.20)	NA
Ferrous fumarate (simultaneous administration, fasted)	324 single dose	50 single dose	0.29 (0.26, 0.33)	0.37 (0.33, 0.42)	NA
Ferrous fumarate (simultaneous administration, fed ^d)	324 single dose	50 single dose	0.75 (0.65, 0.87)	0.84 (0.74, 0.95)	NA

NA= Not Applicable

- All interaction studies conducted in healthy volunteers.
- Study conducted with additional voxilaprevir 100 mg to achieve voxilaprevir exposures expected in HCV-infected patients.
- Maximum strength antacid contained 80 mg aluminum hydroxide, 80 mg magnesium hydroxide, and 8 mg simethicone, per mL.
- Reference treatment administered under fasted conditions.

Table 9 Effect of Other Drugs on TAF^a

Coadministered Drug	Dose of Coadministered Drug (mg)	Tenofovir Alafenamide (mg)	Mean Ratio of Tenofovir Alafenamide Pharmacokinetic Parameters (90% CI); No effect = 1.00		
			C _{max}	AUC	C _{min}
Carbamazepine	300 twice daily	25 single dose ^b	0.43 (0.36, 0.51)	0.46 (0.40, 0.54)	NA
Ledipasvir/sofosbuvir	90/400 once daily	25 once daily	1.17 (1.00, 1.38)	1.27 (1.19, 1.34)	NA
Sofosbuvir/velpatasvir/voxilaprevir	400/100/100 +100 voxilaprevir ^c once daily	25 once daily	1.28 (1.09, 1.51)	1.57 (1.44, 1.71)	NA

NA= Not Applicable

- All interaction studies conducted in healthy volunteers.
- Study conducted with emtricitabine/tenofovir alafenamide.
- Study conducted with additional voxilaprevir 100 mg to achieve voxilaprevir exposures expected in HCV-infected patients.

Effect of BIKTARVY Components on Other Drugs

Table 10 Effect of Components of BIKTARVY on Other Drugs^a

Coadministered Drug	Dose of Coadministered Drug (mg)	BIC (mg)	TAF (mg)	Mean Ratio of Coadministered Drug Pharmacokinetic Parameters (90% CI); No effect = 1.00		
				C _{max}	AUC	C _{min}
Ledipasvir	90/400 once daily	75 once daily	25 once daily	0.85 (0.81, 0.90)	0.87 (0.83, 0.92)	0.90 (0.84, 0.96)
Sofosbuvir				1.11 (1.00, 1.24)	1.07 (1.01, 1.13)	NA
GS-331007 ^b				1.10 (1.07, 1.13)	1.11 (1.08, 1.14)	1.02 (0.99, 1.06)
Metformin	500 twice daily	50 once daily	25 once daily	1.28 (1.21, 1.36)	1.39 (1.31, 1.48)	1.36 (1.21, 1.53)
Midazolam	2 single dose	50 once daily	25 once daily	1.03 (0.87, 1.23)	1.15 (1.00, 1.31)	NA
Norelgestromin	norgestimate 0.180/0.215/0.250 once daily / ethinyl estradiol 0.025 once daily	75 once daily	-	1.23 (1.14, 1.32)	1.08 (1.05, 1.10)	1.10 (1.05, 1.15)
Norgestrel				1.15 (1.10, 1.21)	1.13 (1.07, 1.19)	1.14 (1.06, 1.22)
Ethinyl estradiol				1.15 (1.03, 1.27)	1.04 (0.99, 1.10)	1.05 (0.95, 1.14)
Norelgestromin	norgestimate 0.180/0.215/0.250 once daily / ethinyl estradiol 0.025 once daily	-	25 once daily ^c	1.17 (1.07, 1.26)	1.12 (1.07, 1.17)	1.16 (1.08, 1.24)
Norgestrel				1.10 (1.02, 1.18)	1.09 (1.01, 1.18)	1.11 (1.03, 1.20)
Ethinyl estradiol				1.22 (1.15, 1.29)	1.11 (1.07, 1.16)	1.02 (0.92, 1.12)
Sertraline	50 single dose	-	10 once daily ^d	1.14 (0.94, 1.38)	0.93 (0.77, 1.13)	NA
Sofosbuvir	400/100/100+ 100 ^e once daily	50 once daily	25 once daily	1.14 (1.04, 1.25)	1.09 (1.02, 1.15)	NA
GS-331007 ^b				1.03 (0.99, 1.06)	1.03 (1.00, 1.06)	1.01 (0.98, 1.05)
Velpatasvir				0.96 (0.91, 1.01)	0.96 (0.90, 1.02)	0.94 (0.88, 1.01)

Coadministered Drug	Dose of Coadministered Drug (mg)	BIC (mg)	TAF (mg)	Mean Ratio of Coadministered Drug Pharmacokinetic Parameters (90% CI); No effect = 1.00		
				C _{max}	AUC	C _{min}
Voxilaprevir				0.90 (0.76, 1.06)	0.91 (0.80, 1.03)	0.97 (0.88, 1.06)

NA= Not Applicable

- All interaction studies conducted in healthy volunteers.
- The predominant circulating nucleoside metabolite of sofosbuvir.
- Study conducted with emtricitabine/tenofovir alafenamide.
- Study conducted with elvitegravir/cobicistat/emtricitabine/tenofovir alafenamide.
- Study conducted with additional voxilaprevir 100 mg to achieve voxilaprevir exposures expected in HCV-infected patients.

12.4 Microbiology

Mechanism of Action

Bictegravir: BIC inhibits the strand transfer activity of HIV-1 integrase (integrase strand transfer inhibitor; INSTI), an HIV-1 encoded enzyme that is required for viral replication. Inhibition of integrase prevents the integration of linear HIV-1 DNA into host genomic DNA, blocking the formation of the HIV-1 provirus and propagation of the virus.

Emtricitabine: FTC, a synthetic nucleoside analog of cytidine, is phosphorylated by cellular enzymes to form emtricitabine 5'-triphosphate. Emtricitabine 5'-triphosphate inhibits the activity of the HIV-1 reverse transcriptase by competing with the natural substrate deoxycytidine 5'-triphosphate and by being incorporated into nascent viral DNA which results in chain termination. Emtricitabine 5'-triphosphate is a weak inhibitor of mammalian DNA polymerases α , β , ϵ , and mitochondrial DNA polymerase γ .

Tenofovir Alafenamide: TAF is a phosphoramidate prodrug of tenofovir (2'-deoxyadenosine monophosphate analog). Plasma exposure to TAF allows for permeation into cells and then TAF is intracellularly converted to tenofovir through hydrolysis by cathepsin A. Tenofovir is subsequently phosphorylated by cellular kinases to the active metabolite tenofovir diphosphate. Tenofovir diphosphate inhibits HIV-1 replication through incorporation into viral DNA by the HIV reverse transcriptase, which results in DNA chain-termination. Tenofovir diphosphate is a weak inhibitor of mammalian DNA polymerases that include mitochondrial DNA polymerase γ and there is no evidence of toxicity to mitochondria in cell culture.

Antiviral Activity in Cell Culture

The triple combination of BIC, FTC, and TAF was not antagonistic with respect to antiviral activity in cell culture.

Bictegravir: The antiviral activity of BIC against laboratory and clinical isolates of HIV-1 was assessed in lymphoblastoid cell lines, PBMCs, primary monocyte/macrophage cells, and CD4+ T-lymphocytes. In MT-4 cells (human

lymphoblastoid T-cell line) acutely infected with HIV-1 IIIB, the mean 50% effective concentration (EC₅₀) was 2.4±0.4 nM, and the protein-adjusted EC₉₅ value was 361 nM (0.162 micrograms per mL). BIC displayed antiviral activity in activated PBMCs against clinical isolates of HIV-1 representing groups M, N, and O, including subtypes A, B, C, D, E, F, and G, with a median EC₅₀ value of 0.55 nM (range <0.05 to 1.71 nM). The EC₅₀ value against a single HIV-2 isolate was 1.1 nM.

Emtricitabine: The antiviral activity of FTC against laboratory and clinical isolates of HIV-1 was assessed in T lymphoblastoid cell lines, the MAGI-CCR5 cell line, and PBMCs. In PBMCs acutely infected with HIV-1 subtypes A, B, C, D, E, F, and G, the median EC₅₀ value for FTC was 9.5 nM (range 1 to 30 nM) and against HIV-2 was 7 nM.

Tenofovir Alafenamide: The antiviral activity of TAF against laboratory and clinical isolates of HIV-1 subtype B was assessed in lymphoblastoid cell lines, PBMCs, primary monocyte/macrophage cells and CD4-T lymphocytes. The EC₅₀ values for TAF ranged from 2.0 to 14.7 nM. TAF displayed antiviral activity in cell culture against all HIV-1 groups (M, N, O), including subtypes A, B, C, D, E, F, and G (EC₅₀ values ranged from 0.1 to 12 nM) and strain specific activity against HIV-2 (EC₅₀ values ranged from 0.9 to 2.6 nM).

Resistance

In Cell Culture

Bictegravir: HIV-1 isolates with reduced susceptibility to BIC have been selected in cell culture. In one selection with BIC, a virus pool emerged expressing amino acid substitutions M50I and R263K in the HIV-1 integrase. M50I, R263K, and M50I+R263K substitutions, when introduced into a wild-type virus by site-directed mutagenesis, conferred 1.3-, 2.2-, and 2.9-fold reduced susceptibility to BIC, respectively. In a second selection, emergence of amino acid substitutions T66I and S153F was detected, and 0.4-, 1.9-, and 0.5-fold reductions in BIC susceptibility were observed with T66I, S153F, and T66I+S153F, respectively. In addition, S24G and E157K substitutions emerged during the selection process.

Emtricitabine: HIV-1 isolates with reduced susceptibility to FTC were selected in cell culture and in subjects treated with FTC. Reduced susceptibility to FTC was associated with M184V or I substitutions in HIV-1 RT.

Tenofovir Alafenamide: HIV-1 isolates with reduced susceptibility to TAF were selected in cell culture. HIV-1 isolates selected by TAF expressed a K65R substitution in HIV-1 RT, sometimes in the presence of S68N or L429I substitutions; in addition, a K70E substitution in HIV-1 RT was observed.

In Clinical Trials

In Subjects with No Antiretroviral Treatment History: Pooled genotypic resistance analyses were performed on paired baseline and on-treatment HIV-1 isolates from subjects receiving BIKTARVY through Week 48 in Trials 1489 and 1490 [see *Clinical Studies (14.2)*] who had HIV-1 RNA greater than or equal to 200 copies/mL at the

time of confirmed virologic failure, Week 48, or early study drug discontinuation. No specific amino acid substitutions emerged consistently in the 8 treatment failure subjects with evaluable genotypic resistance data and failed to establish an association with genotypic BIC resistance. There were no treatment-emergent NRTI resistance-associated substitutions detected in the 8 evaluated treatment failure isolates. Phenotypic resistance analyses of failure isolates found fold-changes in drug susceptibility below the biological or clinical cutoffs for BIC, FTC, and TFV, compared to wild-type reference HIV-1.

In Virologically Suppressed Adult Subjects: In 2 switch trials, Trials 1844 and 1878 [see *Clinical Studies (14.3)*], of virologically suppressed HIV-1 infected subjects (n=572), only one subject with virologic rebound in the resistance analysis population had IN genotypic and phenotypic data, and 2 rebounders had RT genotypic and phenotypic data. No subjects had HIV-1 with treatment-emergent genotypic or phenotypic resistance to BIC, FTC, or TAF.

In Virologically Suppressed Pediatric Subjects: In Trial 1474 [see *Clinical Studies (14.4)*], two of 50 subjects in cohort 1 were evaluated for the development of resistance through Week 48; no amino acid substitutions known to be associated with resistance to BIC, FTC, or TFV were detected. No subjects in cohort 2 met the criteria for resistance analyses.

Cross-Resistance

Bictegravir: Cross-resistance has been observed among INSTIs. The susceptibility of BIC was tested against 64 clinical isolates expressing known INSTI resistance-associated substitutions listed by IAS-USA (20 with single substitutions and 44 with 2 or more substitutions). Isolates with a single INSTI-resistance substitution including E92Q, T97A, Y143C/R, Q148R, and N155H showed less than 2-fold reduced susceptibility to BIC. All isolates (n=14) with more than 2.5-fold reduced susceptibility to BIC (above the biological cutoff for BIC) contained G140A/C/S and Q148H/R/K substitutions; the majority (64.3%, 9/14) had a complex INSTI resistance pattern with an additional INSTI-resistance substitution L74M, T97A, or E138A/K. Of those evaluated isolates containing G140A/C/S and Q148H/R/K substitutions in the absence of additional INSTI-resistance substitutions, 38.5% (5/13) showed more than 2.5-fold reduction. In addition, site-directed mutant viruses with G118R (dolutegravir and raltegravir treatment-emergent substitution) and G118R+T97A had 3.4- and 2.8-fold reduced susceptibility to BIC, respectively.

BIC demonstrated equivalent antiviral activity with less than 2-fold reductions in susceptibility against HIV-1 variants expressing substitutions associated with resistance to NNRTIs, NRTIs, and PIs, compared with the wild-type virus.

Emtricitabine: Cross-resistance has been observed among NRTIs. FTC-resistant viruses with an M184V/I substitution in HIV-1 RT were cross-resistant to lamivudine. HIV-1 isolates containing the K65R RT substitution, selected *in vivo* by abacavir, didanosine, and tenofovir, demonstrated reduced susceptibility to inhibition by FTC.

Tenofovir Alafenamide: Cross-resistance has been observed among NRTIs.

Tenofovir resistance substitutions K65R and K70E result in reduced susceptibility to abacavir, didanosine, emtricitabine, lamivudine, and tenofovir. HIV-1 with multiple thymidine analog substitutions (M41L, D67N, K70R, L210W, T215F/Y, K219Q/E/N/R), or multinucleoside resistant HIV-1 with a T69S double insertion mutation or with a Q151M substitution complex including K65R, showed reduced susceptibility to TAF in cell culture.

13 NONCLINICAL TOXICOLOGY

13.1 Carcinogenesis, Mutagenesis, Impairment of Fertility

Bictegravir

BIC was not carcinogenic in a 6-month rasH2 transgenic mouse study at doses of up to 100 mg/kg/day in males and 300 mg/kg/day in females. BIC was not carcinogenic in a 2-year rat study at doses up to 300 mg/kg/day, which resulted in exposures of approximately 31 times the exposure in humans at the recommended dose of BIKTARVY.

BIC was not genotoxic in the reverse mutation bacterial test (Ames test), mouse lymphoma or rat micronucleus assays.

BIC did not affect fertility, reproductive performance or embryonic viability in male and female rats at 29 times higher exposures (AUC) than in humans at the recommended dose of BIKTARVY.

Emtricitabine

In long-term carcinogenicity studies of FTC, no drug-related increases in tumor incidence were found in mice at doses up to 750 mg per kg per day (25 times the human systemic exposure at the recommended dose of BIKTARVY) or in rats at doses up to 600 mg per kg per day (30 times the human systemic exposure at the recommended dose of BIKTARVY).

FTC was not genotoxic in the reverse mutation bacterial test (Ames test), mouse lymphoma or mouse micronucleus assays.

FTC did not affect fertility in male rats at approximately 140 times or in male and female mice at approximately 60 times higher exposures (AUC) than in humans given the recommended dose of BIKTARVY. Fertility was normal in the offspring of mice exposed daily from before birth (in utero) through sexual maturity at daily exposures (AUC) of approximately 60 times higher than human exposures at the recommended dose of BIKTARVY.

Tenofovir Alafenamide

Since TAF is rapidly converted to tenofovir and a lower tenofovir exposure in rats and mice was observed after TAF administration compared to TDF administration, carcinogenicity studies were conducted only with TDF. Long-term oral carcinogenicity

studies of TDF in mice and rats were carried out at exposures up to approximately 10 times (mice) and 4 times (rats) those observed in humans following a 300 mg dose of TDF. The tenofovir exposure in these studies was approximately 151 times (mice) and 51 times (rat) those observed in humans after administration of the daily recommended dose of BIKTARVY. At the high dose in female mice, liver adenomas were increased at tenofovir exposures approximately 151 times the exposure observed in humans at the recommended dose of BIKTARVY. In rats, the study was negative for carcinogenic findings.

TAF was not genotoxic in the reverse mutation bacterial test (Ames test), mouse lymphoma or rat micronucleus assays.

There were no effects on fertility, mating performance or early embryonic development when TAF was administered to male rats at a dose equivalent to 155 times the human dose of BIKTARVY based on body surface area comparisons for 28 days prior to mating and to female rats for 14 days prior to mating through Day 7 of gestation.

13.2 Animal Toxicology and/or Pharmacology

Minimal to slight infiltration of mononuclear cells in the posterior uvea was observed in dogs with similar severity after three and nine month administration of TAF; reversibility was seen after a three month recovery period. No eye toxicity was observed in the dog at systemic exposures of 7 (TAF) and 14 (tenofovir) times the exposure seen in humans with the recommended daily dose of BIKTARVY.

14 CLINICAL STUDIES

14.1 Description of Clinical Trials

The efficacy and safety of BIKTARVY were evaluated in the trials summarized in Table 11.

Table 11 Trials Conducted with BIKTARVY in Subjects with HIV-1 Infection

Trial	Population	Trial Arms (N)	Timepoint (Week)
Trial1489 ^a (NCT 02607930)	Adults with no antiretroviral treatment history	BIKTARVY (314) ABC/DTG/3TC (315)	48
Trial 1490 ^a (NCT 02607956)		BIKTARVY (320) DTG + FTC/TAF(325)	48
Trial 1844 ^a (NCT 02603120)	Virologically-suppressed ^c adults	BIKTARVY (282) ABC/DTG/3TC (281)	48
Trial 1878 ^b (NCT 02603107)		BIKTARVY (290) ATV or DRV (with cobicistat or ritonavir) plus either FTC/TDF or ABC/3TC (287)	48
Trial 1474 ^d (cohort 1) (NCT 02881320)	Virologically-suppressed ^c adolescents between the ages of 12 to less than 18 years (at least 35 kg)	BIKTARVY (50)	48
Trial 1474 ^d (cohort 2) (NCT 02881320)	Virologically-suppressed ^c children between the ages of 6 to less than 12 years (at least 25 kg)	BIKTARVY (50)	24

a. Randomized, double blind, active controlled trial.

b. Randomized, open label, active controlled trial.

c. HIV-1 RNA less than 50 copies per mL.

d. Open label trial.

14.2 Clinical Trial Results in HIV-1 Subjects with No Antiretroviral Treatment History

In Trial 1489, subjects were randomized in a 1:1 ratio to receive either BIKTARVY (N=314) or ABC/DTG/3TC (600 mg/50 mg/300 mg) (N=315) once daily. In Trial 1490, subjects were randomized in a 1:1 ratio to receive either BIKTARVY (N=320) or DTG + FTC/TAF (50 mg + 200 mg/25 mg) (N=325) once daily.

In Trial 1489, the mean age was 34 years (range 18–71), 90% were male, 57% were White, 36% were Black, and 3% were Asian. 22% of patients identified as Hispanic/Latino. The mean baseline plasma HIV-1 RNA was 4.4 log₁₀ copies/mL (range 1.3–6.5). The mean baseline CD4+ cell count was 464 cells per mm³ (range 0–1424) and 11% had CD4+ cell counts less than 200 cells per mm³. 16% of subjects had baseline viral loads greater than 100,000 copies per mL.

In Trial 1490, the mean age was 37 years (range 18–77), 88% were male, 59% were White, 31% were Black, and 3% were Asian. 25% of patients identified as

Hispanic/Latino. The mean baseline plasma HIV-1 RNA was 4.4 log₁₀ copies/mL (range 2.3–6.6). The mean baseline CD4+ cell count was 456 cells per mm³ (range 2–1636) and 12% had CD4+ cell counts less than 200 cells per mm³. 19% of subjects had baseline viral loads greater than 100,000 copies per mL.

In both trials, subjects were stratified by baseline HIV-1 RNA (less than or equal to 100,000 copies per mL, greater than 100,000 copies per mL to less than or equal to 400,000 copies per mL, or greater than 400,000 copies per mL), by CD4 count (less than 50 cells per mm³, 50–199 cells per mm³, or greater than or equal to 200 cells per mm³), and by region (US or ex-US).

Treatment outcomes of Trials 1489 and 1490 through Week 48 are presented in Table 12.

Table 12 Virologic Outcomes of Randomized Treatment in Trials 1489 and 1490 at Week 48^a in Subjects with No Antiretroviral Treatment History

	Trial 1489		Trial 1490	
	BIKTARVY (N=314)	ABC/DTG/3TC (N=315)	BIKTARVY (N=320)	DTG + FTC/TAF (N=325)
HIV-1 RNA < 50 copies/mL	92%	93%	89%	93%
Treatment Difference (95% CI) BIKTARVY vs. Comparator	-0.6% (-4.8% to 3.6%)		-3.5% (-7.9% to 1.0%)	
HIV-1 RNA ≥ 50 copies/mL^b	1%	3%	4%	1%
No Virologic Data at Week 48 Window	7%	4%	6%	6%
Discontinued Study Drug Due to AE or Death ^c	0	1%	1%	1%
Discontinued Study Drug Due to Other Reasons and Last Available HIV-1 RNA <50 copies/mL ^d	5%	3%	3%	4%
Missing Data During Window but on Study Drug	2%	<1%	2%	1%

- Week 48 window was between Day 295 and 378 (inclusive).
- Includes subjects who had ≥ 50 copies/mL in the Week 48 window; subjects who discontinued early due to lack or loss of efficacy; subjects who discontinued for reasons other than an adverse event (AE), death or lack or loss of efficacy and at the time of discontinuation had a viral value of ≥ 50 copies/mL.
- Includes subjects who discontinued due to AE or death at any time point from Day 1 through the time window if this resulted in no virologic data on treatment during the specified window.
- Includes subjects who discontinued for reasons other than an AE, death, or lack or loss of efficacy, e.g., withdrew consent, loss to follow-up, etc.

Treatment outcomes were similar across subgroups by age, sex, race, baseline viral load, and baseline CD4+ cell count.

In Trials 1489 and 1490, the mean increase from baseline in CD4+ count at Week 48 was 233 and 229 cells per mm³ in the BIKTARVY and ABC/DTG/3TC groups,

respectively, and 180 and 201 cells per mm³ in the BIKTARVY and DTG + FTC/TAF groups, respectively.

14.3 Clinical Trial Results in HIV-1 Virologically-Suppressed Subjects Who Switched to BIKTARVY

In Trial 1844, the efficacy and safety of switching from a regimen of DTG + ABC/3TC or ABC/DTG/3TC to BIKTARVY were evaluated in a randomized, double-blind trial of virologically-suppressed (HIV-1 RNA less than 50 copies per mL) HIV-1 infected adults (N=563, randomized and dosed). Subjects must have been stably suppressed (HIV-1 RNA less than 50 copies per mL) on their baseline regimen for at least 3 months prior to trial entry and had no history of treatment failure. Subjects were randomized in a 1:1 ratio to either switch to BIKTARVY at baseline (N=282), or stay on their baseline antiretroviral regimen (N=281). Subjects had a mean age of 45 years (range 20–71), 89% were male, 73% were White, and 22% were Black. 17% of subjects identified as Hispanic/Latino. The mean baseline CD4+ cell count was 723 cells per mm³ (range 124–2444).

In Trial 1878, the efficacy and safety of switching from either ABC/3TC or FTC/TDF (200/300 mg) plus ATV or DRV (given with either cobicistat or ritonavir) to BIKTARVY were evaluated in a randomized, open-label study of virologically-suppressed HIV-1 infected adults (N=577, randomized and dosed). Subjects must have been stably suppressed on their baseline regimen for at least 6 months, must not have been previously treated with any INSTI, and had no history of treatment failure. Subjects were randomized in a 1:1 ratio to either switch to BIKTARVY (N=290) or stay on their baseline antiretroviral regimen (N=287). Subjects had a mean age of 46 years (range 20–79), 83% were male, 66% were White, and 26% were Black. 19% of subjects identified as Hispanic/Latino. The mean baseline CD4+ cell count was 663 cells per mm³ (range 62–2582). Subjects were stratified by prior treatment regimen. At screening, 15% of subjects were receiving ABC/3TC plus ATV or DRV (given with either cobicistat or ritonavir) and 85% of subjects were receiving FTC/TDF plus ATV or DRV (given with either cobicistat or ritonavir).

Treatment outcomes of Trials 1844 and 1878 through Week 48 are presented in Table 13.

Table 13 Virologic Outcomes of Trials 1844 and 1878 at Week 48^a in Virologically-Suppressed Subjects who Switched to BIKTARVY

	Trial 1844		Trial 1878	
	BIKTARVY (N=282)	ABC/DTG/3TC (N=281)	BIKTARVY (N=290)	ATV- or DRV- based regimen ^b (N=287)
HIV-1 RNA \geq 50 copies/mL^c	1%	<1%	2%	2%
Treatment Difference (95% CI)	0.7% (-1.0% to 2.8%)		0.0% (-2.5% to 2.5%)	
HIV-1 RNA < 50 copies/mL	94%	95%	92%	89%
No Virologic Data at Week 48 Window	5%	5%	6%	9%
Discontinued Study Drug Due to AE or Death and Last Available HIV-1 RNA < 50 copies/mL	2%	1%	1%	1%
Discontinued Study Drug Due to Other Reasons and Last Available HIV-1 RNA < 50 copies/mL ^d	2%	3%	3%	7%
Missing Data During Window but on Study Drug	2%	1%	2%	2%

- Week 48 window was between Day 295 and 378 (inclusive).
- ATV given with cobicistat or ritonavir or DRV given with cobicistat or ritonavir plus either FTC/TDF or ABC/3TC.
- Includes subjects who had \geq 50 copies/mL in the Week 48 window; subjects who discontinued early due to lack or loss of efficacy; subjects who discontinued for reasons other than lack or loss of efficacy and at the time of discontinuation had a viral value of \geq 50 copies/mL.
- Includes subjects who discontinued for reasons other than an AE, death, or lack or loss of efficacy, e.g., withdrew consent, loss to follow-up, etc.

In Trial 1844, treatment outcomes between treatment groups were similar across subgroups by age, sex, race, and region. The mean change from baseline in CD4+ count at Week 48 was -31 cells per mm³ in subjects who switched to BIKTARVY and 4 cells per mm³ in subjects who stayed on ABC/DTG/3TC.

In Trial 1878, treatment outcomes between treatment groups were similar across subgroups by age, sex, race, and region. The mean change from baseline in CD4+ count at Week 48 was 25 cells per mm³ in patients who switched to BIKTARVY and 0 cells per mm³ in patients who stayed on their baseline regimen.

14.4 Clinical Trial Results in HIV-1 Infected Pediatric Subjects Between the Ages of 6 to Less than 18 Years

In Trial 1474, an open-label, single arm trial the efficacy, safety, and pharmacokinetics of BIKTARVY in HIV-1 infected pediatric subjects were evaluated in virologically-suppressed adolescents between the ages of 12 to less than 18 years weighing at least 35 kg (N=50) and in virologically-suppressed children between the ages of 6 to less than 12 years weighing at least 25 kg (N=50).

Cohort 1: Virologically-suppressed adolescents (12 to less than 18 years; at least 35 kg)

Subjects in cohort 1 treated with BIKTARVY once daily had a mean age of 14 years (range: 12 to 17) and a mean baseline weight of 51.7 kg (range: 35 to 123), 64% were female, 27% were Asian and 65% were black. At baseline, median CD4+ cell count was 750 cells per mm³ (range: 337 to 1207), and median CD4+% was 33% (range: 19% to 45%).

After switching to BIKTARVY, 98% (49/50) of subjects in cohort 1 remained suppressed (HIV-1 RNA < 50 copies/mL) at Week 48. The mean change from baseline in CD4+ cell count at Week 48 was -22 cells per mm³.

Cohort 2: Virologically-suppressed children (6 to less than 12 years; at least 25 kg)

Subjects in cohort 2 treated with BIKTARVY once daily had a mean age of 10 years (range: 6 to 11) and a mean baseline weight of 31.9 kg (range: 25 to 69), 54% were female, 22% were Asian and 72% were black. At baseline, median CD4+ cell count was 898 cells per mm³ (range 390 to 1991) and median CD4+% was 37% (range: 19% to 53%).

After switching to BIKTARVY, 100% (50/50) of subjects in cohort 2 remained suppressed (HIV-1 RNA < 50 copies/mL) at Week 24. The mean change from baseline in CD4+ cell count at Week 24 was -24 cells per mm³.

16 HOW SUPPLIED/STORAGE AND HANDLING

BIKTARVY tablets are purplish brown, capsule-shaped, and film-coated with “GSI” debossed on one side and “9883” on the other side. Each bottle contains 30 tablets (NDC 61958-2501-1), a silica gel desiccant, polyester coil, and is closed with a child-resistant closure. Each BIKTARVY tablet contains 50 mg of bicitgravir (BIC), 200 mg of emtricitabine (FTC), and 25 mg of tenofovir alafenamide (TAF).

Store below 30 °C (86 °F).

- Keep container tightly closed.
- Dispense only in original container.

17 PATIENT COUNSELING INFORMATION

Advise the patient to read the FDA-approved patient labeling (Patient Information).

Post-treatment Acute Exacerbation of Hepatitis B in Patients with HBV Coinfection

Severe acute exacerbations of hepatitis B have been reported in patients who are coinfecting with HBV and HIV-1 and have discontinued products containing FTC and/or TDF, and may likewise occur with discontinuation of BIKTARVY [see *Warnings and Precautions (5.1)*]. Advise the patient to not discontinue BIKTARVY without first informing their healthcare provider.

Drug Interactions

BIKTARVY may interact with certain drugs; therefore, advise patients to report to their healthcare provider the use of any other prescription or non-prescription medication or herbal products including St. John’s wort [see *Contraindications (4) and Drug Interactions (7)*].

Immune Reconstitution Syndrome

Advise patients to inform their healthcare provider immediately of any symptoms of infection, as in some patients with advanced HIV infection (AIDS), signs and symptoms of inflammation from previous infections may occur soon after anti-HIV treatment is started [see *Warnings and Precautions (5.3)*].

Renal Impairment

Advise patients to avoid taking BIKTARVY with concurrent or recent use of nephrotoxic agents. Renal impairment including cases of acute renal failure has been reported in association with the use of tenofovir prodrugs [see *Warnings and Precautions (5.4)*].

Lactic Acidosis and Severe Hepatomegaly

Lactic acidosis and severe hepatomegaly with steatosis, including fatal cases, have been reported with use of drugs similar to BIKTARVY. Advise patients that they

should stop BIKTARVY if they develop clinical symptoms suggestive of lactic acidosis or pronounced hepatotoxicity [see *Warnings and Precautions (5.5)*].

Missed Dosage

Inform patients that it is important to take BIKTARVY on a regular dosing schedule with or without food and to avoid missing doses as it can result in development of resistance [see *Dosage and Administration (2.2)*].

Pregnancy Registry

Inform patients that there is an antiretroviral pregnancy registry to monitor fetal outcomes of pregnant women exposed to BIKTARVY [see *Use in Specific Populations (8.1)*].

Lactation

Instruct women with HIV-1 infection not to breastfeed because HIV-1 can be passed to the baby in breast milk [see *Use in Specific Populations (8.2)*].

BIKTARVY is a trademark of Gilead Sciences, Inc., or its related companies. All other trademarks referenced herein are the property of their respective owners.

© 2019 Gilead Sciences, Inc. All rights reserved.

Patient Information
BIKTARVY® (bik-TAR-vee)
(bictegravir, emtricitabine,
and tenofovir alafenamide)
tablets

Important: Ask your healthcare provider or pharmacist about medicines that should not be taken with BIKTARVY. For more information, see “What should I tell my healthcare provider before taking BIKTARVY?”

What is the most important information I should know about BIKTARVY?

BIKTARVY can cause serious side effects, including:

- **Worsening of Hepatitis B virus infection. If you have hepatitis B virus (HBV) infection and take BIKTARVY, your HBV may get worse (flare-up) if you stop taking BIKTARVY. A “flare-up” is when your HBV infection suddenly returns in a worse way than before.**
 - Do not run out of BIKTARVY. Refill your prescription or talk to your healthcare provider before your BIKTARVY is all gone.
 - Do not stop taking BIKTARVY without first talking to your healthcare provider. If you stop taking BIKTARVY, your healthcare provider will need to check your health often and do blood tests regularly for several months to check your HBV infection. Tell your healthcare provider about any new or unusual symptoms you may have after you stop taking BIKTARVY.

For more information about side effects, see “What are the possible side effects of BIKTARVY?”

What is BIKTARVY?

BIKTARVY is a prescription medicine that is used without other anti-HIV-1 medicines to treat Human Immunodeficiency Virus-1 (HIV-1) in adults and children who weigh at least 55 pounds (25 kg):

- who have not received anti-HIV-1 medicines in the past, **or**
- to replace their current anti-HIV-1 medicines for people whose healthcare provider determines that they meet certain requirements.

HIV-1 is the virus that causes Acquired Immune Deficiency Syndrome (AIDS).

BIKTARVY contains the medicines bictegravir, emtricitabine, and tenofovir alafenamide.

It is not known if BIKTARVY is safe and effective in children who weigh less than 55 pounds (25 kg).

Do not take BIKTARVY if you also take a medicine that contains:

- dofetilide
- rifampin

What should I tell my healthcare provider before taking BIKTARVY?

Before taking BIKTARVY, tell your healthcare provider about all your medical conditions, including if you:

- have liver problems, including hepatitis B virus infection
- have kidney problems
- are pregnant or plan to become pregnant. It is not known if BIKTARVY can harm your unborn baby. Tell your healthcare provider if you become pregnant during treatment with BIKTARVY.
Pregnancy Registry: There is a pregnancy registry for women who take BIKTARVY during pregnancy. The purpose of this registry is to collect information about the health of you and your baby. Talk with your healthcare provider about how you can take part in this registry.
- are breastfeeding or plan to breastfeed. Do not breastfeed if you take BIKTARVY.
 - You should not breastfeed if you have HIV-1 because of the risk of passing HIV-1 to your baby.
 - At least one of the medicines in BIKTARVY can pass to your baby in your breast milk. It is not known if the other medicines in BIKTARVY can pass into your breast milk.Talk with your healthcare provider about the best way to feed your baby.

Tell your healthcare provider about all the medicines you take, including prescription and over-the-counter medicines, antacids, laxatives, vitamins, and herbal supplements.

Some medicines may interact with BIKTARVY. Keep a list of your medicines and show it to your healthcare provider and pharmacist when you get a new medicine.

- You can ask your healthcare provider or pharmacist for a list of medicines that interact with BIKTARVY.
- **Do not start a new medicine without telling your healthcare provider.** Your healthcare provider can tell you if it is safe to take BIKTARVY with other medicines.

How should I take BIKTARVY?

- Take BIKTARVY exactly as your healthcare provider tells you to take it. BIKTARVY is taken by itself (not with other HIV-1 medicines) to treat HIV-1 infection.
- Take BIKTARVY 1 time each day with or without food.
- Do not change your dose or stop taking BIKTARVY without first talking with your healthcare provider. Stay under a healthcare provider's care during treatment with BIKTARVY.
- If you take antacids that contain aluminum or magnesium, take BIKTARVY at least 2 hours before or 6 hours after you take these antacids.
- If you take supplements or antacids that contain iron or calcium, take BIKTARVY with food at the same time that you take these supplements or antacids.
- Do not miss a dose of BIKTARVY.
- If you take too much BIKTARVY, call your healthcare provider or go to the nearest hospital emergency room right away.
- When your BIKTARVY supply starts to run low, get more from your healthcare provider or pharmacy. This is very important because the amount of virus in your blood may increase if the medicine is stopped for even a short time. The virus may develop resistance to BIKTARVY and become harder to treat.

What are the possible side effects of BIKTARVY?

BIKTARVY may cause serious side effects, including:

- **See “What is the most important information I should know about BIKTARVY?”**
- **Changes in your immune system (Immune Reconstitution Syndrome)** can happen when you start taking HIV-1 medicines. Your immune system may get stronger and begin to fight infections that have been hidden in your body for a long time. Tell your healthcare provider right away if you start having any new symptoms after starting your HIV-1 medicine.
- **New or worse kidney problems, including kidney failure.** Your healthcare provider should do blood and urine tests to check your kidneys when starting and during treatment with BIKTARVY. Your healthcare provider may tell you to stop taking BIKTARVY if you develop new or worse kidney problems.
- **Too much lactic acid in your blood (lactic acidosis).** Too much lactic acid is a serious but rare medical emergency that can lead to death. **Tell your healthcare provider right away if you get these symptoms:** weakness or being more tired than usual, unusual muscle pain, being short of breath or fast breathing, stomach pain with nausea and vomiting, cold or blue hands and feet, feel dizzy or lightheaded, or a fast or abnormal heartbeat.
- **Severe liver problems.** In rare cases, severe liver problems can happen that can lead to death. **Tell your healthcare provider right away if you get these symptoms:** skin or the white part of your eyes turns yellow, dark “tea-colored” urine, light-colored stools, loss of appetite for several days or longer, nausea, or stomach-area pain.

The most common side effects of BIKTARVY are diarrhea, nausea, and headache.

These are not all the possible side effects of BIKTARVY.

Call your doctor for medical advice about side effects. You may report side effects to FDA at 1-800-FDA-1088.

How should I store BIKTARVY?

- Store BIKTARVY below 86°F (30°C).
- Keep BIKTARVY in its original container.
- Keep the container tightly closed.

Keep BIKTARVY and all medicines out of reach of children.

General information about the safe and effective use of BIKTARVY.

Medicines are sometimes prescribed for purposes other than those listed in a Patient Information leaflet. Do not use BIKTARVY for a condition for which it was not prescribed. Do not give BIKTARVY to other people, even if they have the same symptoms you have. It may harm them. If you would like more information, talk with your healthcare provider. You can ask your healthcare provider or pharmacist for information about BIKTARVY that is written for health professionals.

For more information, call 1-800-445-3235 or go to www.BIKTARVY.com.

What are the ingredients in BIKTARVY?

Active ingredients: bicitegravir, emtricitabine, and tenofovir alafenamide.

Inactive ingredients: croscarmellose sodium, magnesium stearate, and microcrystalline cellulose.

The tablets are film-coated with a coating material containing iron oxide black, iron oxide red, polyethylene glycol, polyvinyl alcohol, talc, and titanium dioxide.

Manufactured and distributed by: Gilead Sciences, Inc. Foster City, CA 94404

BIKTARVY is a trademark of Gilead Sciences, Inc., or its related companies. All other trademarks referenced herein are the property of their respective owners.

© 2019 Gilead Sciences, Inc. All rights reserved. 210251-GS-001

PRODUCT MONOGRAPH
INCLUDING PATIENT MEDICATION INFORMATION

BYDUREON[®] BCise[™]

exenatide extended-release injectable suspension

Extended-release suspension, 2 mg/dose once weekly, subcutaneous injection

ATC Code: A10BJ01

Other blood glucose lowering drugs, excl. insulins

AstraZeneca Canada Inc.
1004 Middlegate Road
Mississauga, Ontario
L4Y 1M4
www.astrazeneca.ca

Date of Revision
November 23, 2018

Submission Control No: 211975

BYDUREON[®] is a registered trademark of Amylin Pharmaceuticals LLC used under license by AstraZeneca Canada.

BCise[™] is a trademark of AstraZeneca Pharmaceuticals LP, used with permission by AstraZeneca Canada Inc.

Table of Contents

PART I: HEALTH PROFESSIONAL INFORMATION	3
SUMMARY PRODUCT INFORMATION.....	3
INDICATIONS AND CLINICAL USE	3
CONTRAINDICATIONS.....	4
WARNINGS AND PRECAUTIONS	4
ADVERSE REACTIONS	9
DRUG INTERACTIONS.....	13
DOSAGE AND ADMINISTRATION.....	15
OVERDOSAGE.....	17
ACTION AND CLINICAL PHARMACOLOGY	17
STORAGE AND STABILITY	22
SPECIAL HANDLING INSTRUCTIONS.....	22
DOSAGE FORMS, COMPOSITION AND PACKAGING.....	23
PART II: SCIENTIFIC INFORMATION.....	24
PHARMACEUTICAL INFORMATION	24
CLINICAL TRIALS	25
DETAILED PHARMACOLOGY.....	28
TOXICOLOGY	30
REFERENCES.....	33
PATIENT MEDICATION INFORMATION.....	34

BYDUREON® BCise™
exenatide extended-release injectable suspension

PART I: HEALTH PROFESSIONAL INFORMATION

SUMMARY PRODUCT INFORMATION

Route of Administration	Dosage Form / Strength	Clinically Relevant Nonmedicinal Ingredients
Subcutaneous	Exenatide Extended-Release Injectible Suspension: Suspension/2 mg/dose (weekly)	Poly (D,L-lactide-co-glycolide) Medium chain triglycerides (MCT) <i>For a complete listing see DOSAGE FORMS, COMPOSITION AND PACKAGING section.</i>

INDICATIONS AND CLINICAL USE

Monotherapy:

BYDUREON BCise is indicated as an adjunct to diet and exercise to improve glycemic control in patients with type 2 diabetes mellitus for whom metformin is inappropriate due to contraindications or intolerance.

Combination with metformin:

BYDUREON BCise is indicated in patients with type 2 diabetes mellitus to improve glycemic control in combination with metformin when metformin used alone, with diet and exercise, does not provide adequate glycemic control.

Combination with a sulfonylurea:

BYDUREON BCise is indicated in patients with type 2 diabetes mellitus to improve glycemic control in combination with a sulfonylurea when the sulfonylurea used alone, with diet and exercise, does not provide adequate glycemic control.

Combination with metformin and a sulfonylurea:

BYDUREON BCise is indicated in patients with type 2 diabetes mellitus to improve glycemic control in combination with metformin and a sulfonylurea when dual therapy with these two agents, with diet and exercise, does not provide adequate glycemic control.

Geriatrics (≥65 years of age):

Greater sensitivity of some older individuals cannot be ruled out. Clinical experience in patients 75 years of age and older is very limited. Therefore, use with caution in the elderly (see WARNINGS AND PRECAUTIONS; DOSAGE AND ADMINISTRATION and ACTION AND CLINICAL PHARMACOLOGY).

Pediatrics (<18 years of age):

The safety and efficacy of BYDUREON BCise has not been established in pediatric patients. Therefore, BYDUREON BCise should not be used in pediatric patients.

CONTRAINDICATIONS

BYDUREON BCise is contraindicated in patients with:

- known hypersensitivity to this product or any of its components. For a complete listing of ingredients, see the DOSAGE FORMS, COMPOSITION AND PACKAGING section of the Product Monograph.
- a personal or family history of medullary thyroid carcinoma (MTC) or in patients with Multiple Endocrine Neoplasia syndrome type 2 (MEN 2) (see WARNINGS AND PRECAUTIONS).
- end-stage renal disease (ESRD) or severe renal impairment (creatinine clearance <30 mL/min), including patients on dialysis (see WARNINGS AND PRECAUTIONS and ACTION AND CLINICAL PHARMACOLOGY, Pharmacokinetics, Special Populations and Conditions).

WARNINGS AND PRECAUTIONS**Serious Warnings and Precautions****Thyroid C-cell tumours**

- BYDUREON BCise is contraindicated in patients with a personal or family history of medullary thyroid carcinoma (MTC) or in patients with Multiple Endocrine Neoplasia syndrome type 2 (MEN 2) (see CONTRAINDICATIONS).
- Exenatide extended-release causes an increased incidence of thyroid C-cell tumours at clinically relevant exposures in rats, compared to controls. It is unknown whether BYDUREON BCise cause thyroid C-cell tumours, including MTC, in humans (see PART II: SCIENTIFIC INFORMATION, TOXICOLOGY, Carcinogenicity).
- Patients should be counselled regarding the potential risk for MTC with the use of BYDUREON BCise, and informed of symptoms of thyroid tumours (e.g., mass in the neck, dysphagia, dyspnea, persistent hoarseness). Routine monitoring of serum calcitonin or thyroid ultrasound is of uncertain value for early detection of MTC in patients treated with BYDUREON BCise.

General

BYDUREON BCise should not be used in patients with type 1 diabetes or for the treatment of diabetic ketoacidosis.

BYDUREON (exenatide for extended-release injectable suspension), BYDUREON BCise, or BYETTA[®] (exenatide twice daily) should not be used concomitantly, as they contain the same medicinal ingredient and this could result in an overdose.

BYDUREON BCise should not be used in combination with other GLP-1 agonists or dipeptidyl peptidase-4 (DPP-4) inhibitors, as these have similar mechanisms of action and have not been studied together.

The concurrent use of BYDUREON BCise with insulin has not been studied and is not recommended.

BYDUREON BCise has not been studied with warfarin. There have been spontaneously reported cases of increased INR, sometimes associated with bleeding, with concomitant use of warfarin and exenatide. Closer monitoring of INR is recommended after initiation or alteration of exenatide therapy in patients taking warfarin (see ADVERSE REACTIONS, Post-Market Adverse Drug Reactions and DRUG INTERACTIONS, Drug-Drug Interactions).

After discontinuation of BYDUREON BCise, plasma levels of exenatide decline over 10 weeks (see ACTION AND CLINICAL PHARMACOLOGY). Choice of other medicinal products and dose selection should be considered accordingly, as adverse reactions may continue and the anti-glycemic effect may persist until exenatide levels decline (see DOSAGE AND ADMINISTRATION, Dosing Consideration).

BYDUREON BCise must not be administered by intravenous or intramuscular injection (see DOSAGE AND ADMINISTRATION).

Carcinogenesis and Mutagenesis

Risk of Thyroid C-cell tumours

BYDUREON BCise is contraindicated in patients with a personal or family history of medullary thyroid carcinoma (MTC) or in patients with Multiple Endocrine Neoplasia syndrome type 2 (MEN 2) (see CONTRAINDICATIONS).

Exenatide extended-release caused a dose-related and treatment-duration-dependent increase in the incidence of thyroid C-cell tumours (adenomas and/or carcinomas) at clinically relevant exposures in rats, compared to controls. A statistically significant increase in malignant thyroid C-cell carcinomas was observed in female rats receiving exenatide extended-release at 25-times clinical exposure compared to controls, and higher incidences were noted in males compared to controls in all treated groups at ≥ 2 -times clinical exposure. It is unknown whether BYDUREON BCise will cause thyroid C-cell tumours, including MTC, in humans,

as the human relevance of exenatide extended-release-induced rodent thyroid C-cell tumours has not been determined (see TOXICOLOGY, Carcinogenicity).

Serum calcitonin is a biological marker of MTC. Patients with MTC usually have calcitonin values >50 ng/L. Patients with thyroid nodules noted on physical examination or neck imaging or elevated levels of serum calcitonin should be evaluated. Routine monitoring of serum calcitonin or thyroid ultrasound is of uncertain value for early detection of MTC in patients treated with BYDUREON BCise.

Cardiovascular

Heart Rate Increase: Exenatide extended-release causes an increase in heart rate, which may lead to worsening of cardiac conditions in patients with a history of ischemic heart disease or tachyarrhythmias. Caution should be observed in these patient populations (see ADVERSE REACTIONS; DRUG INTERACTIONS, Drug-Drug Interactions and ACTION AND CLINICAL PHARMACOLOGY, Cardiac Electrophysiology).

PR Interval Prolongation: Exenatide extended-release causes a prolongation of the heart rate-corrected PR interval of the electrocardiogram (see DRUG INTERACTIONS, Drug-Drug Interactions and ACTION AND CLINICAL PHARMACOLOGY, Cardiac Electrophysiology). Caution should be observed in patients with underlying structural heart disease, pre-existing conduction system abnormalities, ischemic heart disease, or cardiomyopathies, as these patients may be at increased risk for developing cardiac conduction abnormalities. Prolongation of the PR interval has also been associated with an increased risk of incident atrial fibrillation; therefore, caution is warranted in patients with a history of atrial fibrillation.

Endocrine and Metabolism

Hypoglycemia

Use with a sulfonylurea: The risk of hypoglycemia was increased when BYDUREON BCise was used in combination with a sulfonylurea in clinical trials (see ADVERSE REACTIONS). To reduce the risk of hypoglycemia associated with the use of a sulfonylurea, a decrease in the dose of sulfonylurea may be considered (see DOSAGE AND ADMINISTRATION, Recommended Dose and Dosage Adjustment).

Gastrointestinal

Exenatide has not been studied in patients with severe gastrointestinal disease, including gastroparesis. Its use is commonly associated with gastrointestinal adverse effects, including nausea, vomiting, and diarrhea. Therefore, the use of BYDUREON BCise is not recommended in patients with severe gastrointestinal disease.

Hepatic/Biliary/Pancreas

Pancreatitis

Based on post-market data, exenatide has been associated with acute pancreatitis, including fatal and non-fatal hemorrhagic or necrotizing pancreatitis. After initiation of BYDUREON BCise, patients should be observed carefully for signs and symptoms of pancreatitis (including persistent severe abdominal pain, sometimes radiating to the back, which may be accompanied by vomiting). If pancreatitis is suspected, BYDUREON BCise should promptly be discontinued and appropriate management should be initiated. If pancreatitis is confirmed, BYDUREON BCise should not be restarted. Antidiabetic therapies other than BYDUREON BCise may be considered in patients with a history of pancreatitis or in patients with other risk factors for pancreatitis (e.g. gallstones, alcoholism, or hypertriglyceridemia).

Immune

Hypersensitivity

Serious hypersensitivity reactions, including anaphylaxis and angioedema, have been reported post-market in patients treated with exenatide. If a hypersensitivity reaction is suspected, discontinue BYDUREON BCise, assess for other potential causes and institute alternative treatment for diabetes (see ADVERSE REACTIONS, Post-Market Adverse Drug Reactions).

Immunogenicity

Patients may develop antibodies to exenatide following treatment with BYDUREON BCise.

In controlled studies with BYDUREON BCise, approximately 74% of patients developed antibodies (ranging from 71 to 76%), and at week 28, approximately 57% of patients had antibodies.

High titers of anti-exenatide antibodies may result in an attenuated glycemic response to BYDUREON BCise. If there is worsening glycemic control or failure to achieve targeted glycemic control with BYDUREON BCise, alternative antidiabetic therapy should be considered.

Injection-Site Reactions

Serious injection-site reactions (e.g., abscess, cellulitis, and necrosis), with or without subcutaneous nodules, have been reported post-market with the use of exenatide extended-release (BYDUREON). Isolated cases required surgical intervention.

The overall incidence of potentially immune-related injection site reactions (such as injection site pruritus, injection site erythema, and injection site nodule), for BYDUREON BCise, was higher in antibody-positive patients, compared with antibody negative patients, with a greater incidence in those with higher titer antibodies (see ADVERSE REACTIONS).

Renal

BYDUREON BCise is contraindicated in patients with severe renal impairment (creatinine clearance <30mL/min) or end-stage renal disease (ESRD), including patients receiving dialysis, as it has not been investigated in this patient population (see CONTRAINDICATIONS).

Clinical experience in patients with moderate renal impairment (creatinine clearance 30 to 50 mL/min) is very limited; therefore, BYDUREON BCise should be used with caution in patients with moderate renal impairment and renal transplant patients.

There have been spontaneously reported events of altered renal function with exenatide, including increased serum creatinine, renal impairment, worsened chronic renal failure and acute renal failure, sometimes requiring hemodialysis or kidney transplantation. Some of these events occurred in patients receiving one or more pharmacologic agents known to affect renal function/hydration status and/or in patients experiencing events that may affect hydration, including nausea, vomiting and/or diarrhea. Concomitant agents included angiotensin converting enzyme inhibitors, nonsteroidal anti-inflammatory drugs, and diuretics. Reversibility of altered renal function has been observed with supportive treatment and discontinuation of exenatide and potentially causative agents.

Special Populations

Pregnant Women: BYDUREON BCise should not be used during pregnancy. There are no adequate and well-controlled studies in pregnant women. The potential risk for humans is unknown.

Administration of exenatide extended-release to pregnant rats during organogenesis caused fetal growth retardation. Based on animal data, exenatide may cause fetal harm (see PART II: TOXICOLOGY).

Women of childbearing potential: Women of childbearing potential should use contraception during treatment with BYDUREON BCise. Due to its long washout period, BYDUREON BCise should be discontinued at least 3 months before a planned pregnancy.

Nursing Women: There are no adequate and well-controlled studies in nursing women. BYDUREON BCise is not recommended for use in nursing women (see PART II: TOXICOLOGY).

Pediatrics (<18 years of age): The safety and efficacy of BYDUREON BCise has not been established in pediatric patients. BYDUREON BCise should not be used in pediatric patients.

Geriatrics (≥65 years of age): Greater sensitivity of some older individuals cannot be ruled out. Clinical experience in patients 75 years of age and older is very limited. Therefore, use BYDUREON BCise with caution in the elderly (see WARNINGS AND PRECAUTIONS; DOSAGE AND ADMINISTRATION and ACTION AND CLINICAL PHARMACOLOGY).

Monitoring and Laboratory Tests

Renal Function

Assessment of renal function is recommended prior to initiation BYDUREON BCise and periodically thereafter, as appropriate (see CONTRAINDICATIONS and DOSAGE AND ADMINISTRATION).

Anticoagulation

INR should be monitored frequently until stable when BYDUREON BCise is co-administered with warfarin (see DRUG INTERACTIONS).

ADVERSE REACTIONS

Adverse Drug Reaction Overview

The safety of BYDUREON BCise was assessed in one 28-week, comparator-controlled trial (n=229), and one 28-week, placebo- and comparator-controlled trial (n=181), with a total of 410 patients with type 2 diabetes.

In these trials, the most commonly observed adverse events in BYDUREON BCise-treated patients were: gastrointestinal disorders [nausea (9.3%), diarrhea (4.1%), vomiting (3.4%)] injection site reactions [nodules (12.2%), pruritis (3.7%)], and headache (5.1%).

Serious adverse events were reported in 2.4% of BYDUREON BCise-treated patients. No single SAE was reported with an incidence greater than 0.2%.

The incidence of discontinuation of treatment due to adverse events was 3.9% (n=16) for BYDUREON BCise-treated patients. The most common adverse events leading to discontinuation of treatment for BYDUREON BCise-treated patients were nausea (0.7%) and diarrhea (0.7%), vomiting (0.5%), and injection site nodule (0.5%).

Clinical Trial Adverse Drug Reactions

Because clinical trials are conducted under very specific conditions, the adverse reaction rates observed in the clinical trials may not reflect the rates observed in practice and should not be compared to the rates in the clinical trials of another drug. Adverse drug reaction information from clinical trials is useful for identifying drug-related adverse events and for approximating rates.

Table 1 summarizes the incidences of treatment-related adverse events with an incidence of $\geq 1\%$ and reported in at least two BYDUREON BCise-treated patients in any of the studies within the table. These are provided for two placebo- and comparator-controlled 28-week trials of BYDUREON BCise used as monotherapy and in combination with metformin, a sulfonylurea, a thiazolidinedione, or a combination of any two of these therapies.

Table 1 Treatment-related^a adverse events (excluding hypoglycemia^b) reported in $\geq 1\%$ and at least two BYDUREON BCise-treated patients in comparator-controlled trials in monotherapy and in combination with metformin, a sulfonylurea, a thiazolidinedione, or a combination of any two of these therapies

System Organ Class/Preferred Term	Study BCB118 (N=377) 28 weeks		Study BCB120 (N=364) 28 weeks		
	BYDUREON BCise 2 mg QW SC (N=229)	BYETTA 5 µg/10 µg BID (N=146)	BYDUREON BCise 2 mg QW SC (N=181)	Sitagliptin 100 mg/day (N=122)	Placebo (N=61)
	%		%		
Gastrointestinal disorders					
Abdominal distension	2.2	0	0	0	0
Diarrhea	2.6	4.1	1.7	0.8	1.6
Nausea	8.7	18.5	6.6	0.8	0
Vomiting	2.2	3.4	2.8	0	0
General disorders and administration site conditions					
Injection site bruising	2.6	0	2.8	0	0
Injection site erythema	3.5	0.7	1.7	0	0
Injection site induration	0	0	3.9	0	0
Injection site nodule	15.3	0.7	7.2	0	0
Injection site pain	2.6	0	0	0	0
Injection pruritus	4.4	0.7	2.8	0	0
Injection site swelling	0	0	1.1	0	0
Nervous system disorders					
Headache	1.3	2.1	0	0	0

^a As assessed by the clinical investigator.

^b See Hypoglycemia subsection of ADVERSE REACTIONS, and Table 2.
QW Once Weekly; SC subcutaneous

Less Common Clinical Trial Adverse Drug Reactions

The following is a list of less common treatment-related adverse events, reported in <1% of patients (and in at least 2 patients) and reported at a greater frequency in BYDUREON BCise-treated patients than in placebo-treated or comparator-treated patients in two 28-week studies, and which are not represented in Table 1.

Gastrointestinal disorders: Dyspepsia, Constipation, Gastrooesophageal reflux disease
General disorders and administration site conditions: Fatigue, Injection site reactions, Injection site swelling, Injection site haemorrhage, Injection site mass
Metabolism and nutrition disorders: Hyperlipidaemia, Hyperuricaemia
Nervous system disorders: Dizziness, Dysgeusia
Musculoskeletal and connective tissue disorders: Muscle spasms
Skin and subcutaneous tissue disorders: Urticaria

Immunogenicity

Patients may develop antibodies to exenatide following treatment with BYDUREON BCise.

Anti-exenatide antibodies were measured in 393 BYDUREON BCise-treated patients in two comparator-controlled 28-week studies of BYDUREON BCise. The incidence of treatment-emergent antibodies to BYDUREON BCise at the last treatment visit was approximately 57%. Approximately 42% of these patients developed low titer antibodies (<625) to exenatide and approximately 32% of patients developed high titer antibodies (\geq 625) at any time during the studies.

The level of glycemic control (i.e., reduction in HbA1c) in patients with low antibody titers (<625) (-1.1 to -1.5%) was generally comparable to that observed in patients negative for anti-exenatide antibodies (-1.1 to -1.4%). Patients with higher titer antibodies may have an attenuated HbA1c response (-0.6 to -0.7%). If there is worsening of glycemic control or failure to achieve targeted glycemic control, alternative antidiabetic therapy should be considered (see WARNINGS AND PRECAUTIONS, Immune).

Amongst BYDUREON BCise-treated patients evaluable for antibodies (N=393), the incidence of potentially immunogenic injection site reactions (including injection site nodule, pruritus, erythema and induration) during the two 28-week studies was approximately 21% for antibody-positive patients and 15.7% for antibody-negative patients (see WARNINGS AND PRECAUTIONS, Immune). These reactions were less commonly observed in antibody-negative patients (15.7%) and patients with low titer antibodies (16.3%) compared with those with high titer antibodies (27.2%).

Injection Site Reactions

Injection site reactions were observed more frequently in BYDUREON BCise-treated patients than in BYETTA (exenatide twice daily)-treated patients. Subcutaneous injection site nodules were observed very frequently; most were asymptomatic and resolved over 4 to 8 weeks (see WARNINGS AND PRECAUTIONS, Immune).

Serious injection-site reactions have been reported with post-market use of exenatide extended-release (BYDUREON), including abscess, cellulitis, and necrosis, with or without subcutaneous nodules, and rare cases have required surgical treatment.

Hypoglycemia

The incidence of hypoglycemia was increased when BYDUREON BCise was used in combination with a sulfonylurea (see WARNINGS AND PRECAUTIONS, Hypoglycemia). To reduce the risk of hypoglycemia associated with the use of a sulfonylurea, reduction in the dose of sulfonylurea may be considered (see DOSAGE AND ADMINISTRATION, Recommended Dose and Dosage Adjustment).

Table 2 summarizes the incidence and rate of minor hypoglycemia in the 2 comparator-controlled 28-week trials of BYDUREON BCise used as a monotherapy or as add-on to metformin, a sulfonylurea, a thiazolidinedione, or a combination of any two of these therapies. In these trials, a minor hypoglycemia event was defined as symptoms of hypoglycemia with a

concomitant glucose <3 mmol/L prior to treatment.

Table 2 Incidence (% of subjects) and Rate (episodes/subject year) of Minor^ϕ Hypoglycemia in the BYDUREON BCise Phase 3 Controlled Trials

Study	Incidence: % of subjects (Event rate episodes/subject year)
BCB118 (N=377); 28-week, comparator-controlled study comparing BYDUREON BCise (exenatide once weekly suspension) to BYETTA (exenatide twice daily) in patients who were inadequately treated with diet and exercise alone or with oral antidiabetic therapy, including metformin, a sulfonylurea, a thiazolidinedione, or a combination of any two of these therapies.	
With Concomitant Sulfonylurea Use	
BYDUREON BCise 2 mg QW SC (N=88)	26.1 (1.87)
BYETTA 5 ug BID, then 10 ug BID (N=62)	17.7 (1.11)
Without Concomitant Sulfonylurea Use	
BYDUREON BCise 2 mg QW SC (N=141)	2.1 (0.16)
BYETTA 5 ug BID, then 10 ug BID (N=84)	4.8 (0.18)
BCB120 (N=364); 28-week, comparator-and placebo-controlled study comparing BYDUREON BCise (exenatide once weekly suspension) to sitagliptin and placebo in patients inadequately treated with metformin.	
BYDUREON BCise 2 mg QW SC (N=181)	0 (0.0)
Sitagliptin 100 mg/day (N=122)	0.8 (0.02)
Placebo (N=61)	0 (0.0)

QW Once Weekly; SC subcutaneous; BID twice daily

^ϕ Reported event that has symptoms consistent with hypoglycemia with a concomitant glucose <3 mmol/L
N = All treated.

There were no reported events of major hypoglycemia in BYDUREON BCise treated patients in the two 28-week comparator-controlled trials. Major hypoglycemia was defined as loss of consciousness, seizure, or coma (or other mental status change consistent with neuroglycopenia) which resolved after administration of glucagon or glucose. In addition, any event that required third-party assistance to resolve due to severe impairment in consciousness or behavior, and was associated with concomitant glucose <3 mmol/L, was also defined as major hypoglycemia.

Increased Heart Rate

A mean increase in heart rate (HR) of 2.4 beats per minute (bpm) from baseline (74 bpm) was observed in the pooled phase 3 BYDUREON BCise clinical studies, compared to 0.2 bpm (BYETTA) in BCB118, and 0.8 bpm (sitagliptin) and 0.6 bpm (placebo) in BCB120.

Post-Market Adverse Drug Reactions

Additional adverse reactions have been reported with exenatide extended-release (BYDUREON). Because these reactions are reported voluntarily from a population of

uncertain size, it is generally not possible to reliably estimate their frequency or establish a causal relationship to drug exposure.

Gastrointestinal Disorders: Abdominal distension, Abdominal pain, Acute pancreatitis, Hemorrhagic and necrotizing pancreatitis (sometimes fatal), Constipation, Eructation, Flatulence

General Disorders and Administration Site Conditions: Injection-site reactions

Immune System Disorders: Anaphylactic reaction

Investigations: INR increased with concomitant warfarin use (some reports associated with bleeding)

Metabolism and Nutrition Disorders: Dehydration (generally associated with nausea, vomiting and/or diarrhea), Weight decreased

Nervous System Disorders: Dysgeusia, Somnolence

Renal and Urinary Disorders: Altered renal function, including acute renal failure (sometimes requiring hemodialysis), Worsened chronic renal failure, Renal impairment, Increased serum creatinine, Kidney transplant, Kidney transplant dysfunction

Skin and Subcutaneous Tissue Disorders: Alopecia, Angioedema, Generalized pruritus and/or urticaria, Macular or papular rash

DRUG INTERACTIONS

Overview

Drug interactions between BYDUREON BCise and metformin or a sulfonylurea have not been studied in specific pharmacokinetic drug-drug interaction studies. The dose of a sulfonylurea may require adjustment due to the increased risk of hypoglycemia associated with sulfonylurea therapy (see WARNINGS AND PRECAUTIONS, Endocrine and Metabolism; ADVERSE REACTIONS, Hypoglycemia and DOSAGE AND ADMINISTRATION, Recommended Dose and Dosage Adjustment).

Drug-Drug Interactions

Drugs that Increase Heart Rate: Exenatide extended-release causes an increase in heart rate (see ADVERSE REACTIONS and ACTION AND CLINICAL PHARMACOLOGY, Cardiac Electrophysiology). Caution should be observed if BYDUREON BCise is administered with other drugs that also increase heart rate, such as drugs with sympathomimetic or anticholinergic activity (see WARNINGS AND PRECAUTIONS, Cardiovascular).

Drugs that Cause PR Interval Prolongation: Exenatide extended-release causes an increase in the PR interval (see ACTION AND CLINICAL PHARMACOLOGY, Cardiac Electrophysiology). The impact on the PR interval of co-administration of BYDUREON BCise with other drugs that prolong the PR interval (including, but not limited to, antiarrhythmics, non-dihydropyridine calcium channel blockers, beta adrenoceptor blockers, digitalis glycosides, HIV protease inhibitors, and somatostatin analogues) has not been evaluated. As a result, co-administration of BYDUREON BCise with these drugs should be undertaken with caution (see WARNINGS AND PRECAUTIONS, Cardiovascular).

Orally Administered Drugs: In a study using 1000 mg acetaminophen as a marker of gastric emptying, either with or without a meal, following 14 weeks of exenatide extended-release (BYDUREON) therapy (2 mg weekly), no significant changes in acetaminophen AUC were observed compared to the control period. Acetaminophen C_{max} decreased by 16% (fasting) and 5% (fed) and T_{max} was increased from approximately 1 hour in the control period to 1.4 hours (fasting) and 1.3 hours (fed). Exenatide extended-release (BYDUREON) has no clinically significant effect on acetaminophen pharmacokinetics.

However, exenatide slows gastric emptying which has the potential to reduce the rate of absorption of some orally administered drugs. Use with caution when administering oral medications with BYDUREON BCise.

The following drug interaction studies have been conducted with exenatide BID (BYETTA) but not with BYDUREON BCise.

Digoxin: Co-administration of repeated doses of exenatide 10 µg BID decreased the C_{max} of oral digoxin (0.25 mg QD) by 17% and delayed the T_{max} by approximately 2.5 h; however, the overall steady-state pharmacokinetic exposure (AUC) was not changed.

HMG CoA reductase inhibitors: Lovastatin AUC and C_{max} were decreased approximately 40% and 28%, respectively, and T_{max} was delayed about 4 h when exenatide 10 µg BID was administered concomitantly with a single dose of lovastatin (40 mg) compared with lovastatin administered alone.

Lisinopril: In patients with mild to moderate hypertension stabilized on lisinopril (5 to 20 mg/day), exenatide 10 µg BID did not alter steady-state C_{max} or AUC of lisinopril. Lisinopril steady-state T_{max} was delayed by 2 h. There were no changes in 24-h mean systolic and diastolic blood pressure.

Warfarin: In a controlled clinical pharmacology study in healthy volunteers taking exenatide (5 µg BID daily on days 1-2 and 10 µg BID on days 3-9), a delay in warfarin T_{max} of about 2 hours was observed when warfarin was administered 35 minutes after exenatide administration on Day 4. No clinically relevant effects on C_{max} or AUC were observed and exenatide 10 µg BID did not have a significant effect on INR. However there have been spontaneously reported cases of increased INR, sometimes associated with bleeding, with concomitant use of warfarin and exenatide. Closer monitoring of INR is recommended after initiation or alteration of exenatide therapy in patients taking warfarin (see WARNINGS AND PRECAUTIONS, General and ADVERSE REACTIONS, Post-Market Adverse Drug Reactions).

Combination Oral Contraceptives (ethinyl estradiol and levonorgestrel): In healthy females, the administration of a combination oral contraceptive, ethinyl estradiol and levonorgestrel, 30 min after exenatide 10 µg BID resulted in a 45% reduction of the C_{max} of ethinyl estradiol, a 27% to 41% reduction in C_{max} of levonorgestrel, and a delay in T_{max} of up

to approximately 4.5 h; however, exenatide 10 µg BID did not affect AUC of ethinyl estradiol or levonorgestrel. When the oral contraceptive was administered 1 hour before exenatide BID, pharmacokinetic profiles of ethinyl estradiol or levonorgestrel were not altered.

Drug-Food Interactions

Interactions with food have not been established.

Drug-Herb Interactions

Interactions with herbal products have not been established.

Drug-Laboratory Interactions

Interactions with laboratory tests have not been established.

Drug-Lifestyle Interactions

When exenatide is used in combination with a sulfonylurea, patients should be advised to take precautions to avoid hypoglycemia while driving or using machinery.

DOSAGE AND ADMINISTRATION

Dosing Considerations

Switching from BYETTA (exenatide twice daily) to BYDUREON BCise (exenatide extended-release injectable suspension): Patients switching from BYETTA to BYDUREON BCise may experience transient elevations in blood glucose concentrations, which generally improve within two to four weeks after initiation of therapy.

Switching between BYDUREON (exenatide for extended-release injectable suspension) and BYDUREON BCise (exenatide extended-release injectable suspension): Patients switching between BYDUREON and BYDUREON BCise may do so, with minimal expected effect on blood glucose concentrations.

Discontinuation of BYDUREON BCise: After discontinuation of BYDUREON BCise, plasma levels of exenatide decline over 10 weeks (see WARNINGS AND PRECAUTIONS, General; DOSAGE AND ADMINISTRATION and ACTION AND CLINICAL PHARMACOLOGY). Choice of other medicinal products and dose selection should be considered accordingly, as adverse reactions may continue and the anti-hyperglycemic effect may persist until exenatide levels decline.

The concurrent use of BYDUREON BCise with insulin has not been studied and is not recommended.

Recommended Dose and Dosage Adjustment

BYDUREON BCise should be administered once every seven days (weekly). The dose can be administered at any time of day, with or without meals.

When BYDUREON BCise is added to sulfonylurea therapy, a decrease in the dose of the sulfonylurea may be considered to reduce the risk of hypoglycemia (see WARNINGS AND PRECAUTIONS, Endocrine and Metabolism).

Renal Impairment

BYDUREON BCise is contraindicated in patients with end-stage renal disease (ESRD) or severe renal impairment (creatinine clearance <30 mL/min), including patients on dialysis (see CONTRAINDICATIONS).

No dosage adjustment of BYDUREON BCise is required in patients with mild renal impairment (creatinine clearance 50 to 80 mL/min). BYDUREON BCise should be used with caution in patients with moderate renal impairment (creatinine clearance 30 to 50 mL/min) and renal transplant patients (see WARNINGS AND PRECAUTIONS, Renal and ACTION AND CLINICAL PHARMACOLOGY, Special Populations and Conditions).

Hepatic Impairment

No dosage adjustment is required in patients with hepatic impairment (see ACTION AND CLINICAL PHARMACOLOGY, Special Populations and Conditions).

Geriatrics (≥65 years of age)

A greater sensitivity of some older individuals cannot be ruled out. Use caution when initiating BYDUREON BCise in patients 65 years of age or older (see WARNINGS AND PRECAUTIONS, Special Populations).

Missed Dose

If a dose of BYDUREON BCise is missed, the patient should take it as soon as they remember within 3 days after the missed dose. The patient can take the next dose at the usual weekly time.

If it has been longer than 3 days after the missed dose, the patient should skip the dose and take BYDUREON BCise at the next usual weekly time. The patient should not take an extra dose of BYDUREON BCise to make up for the missed dose.

Administration

Appropriate training is recommended for non-healthcare professionals administering BYDUREON BCise. The “Instructions for Use”, which are attached to the PATIENT MEDICATION INFORMATION and also provided in the carton, must be followed carefully by the patient.

BYDUREON BCise is intended for subcutaneous (SC) self-administration by the patient, and must not be administered intravenously or intramuscularly. BYDUREON BCise is administered as a SC injection in the abdomen, thigh or upper arm region. Advise patients to use a different injection site each week when injecting in the same region.

BYDUREON BCise is supplied as an autoinjector, containing a suspension of exenatide packaged in a 2-mL glass cartridge. The autoinjector contains an integrated needle.

BYDUREON BCise must be removed from the refrigerator 15 minutes before use. The suspension must be mixed by shaking hard for at least 15 seconds, and visually inspected prior to use. The suspension should only be used if it is evenly mixed and cloudy with no white medicine seen along the side, bottom or top of the autoinjector window. BYDUREON BCise must be injected immediately after the autoinjector is prepared.

OVERDOSAGE

Signs and symptoms of overdose that may be observed with BYDUREON BCise include severe nausea, severe vomiting and rapidly declining blood glucose concentrations. In the event of overdose, appropriate supportive treatment should be initiated according to the patient's clinical signs and symptoms and should include close monitoring of blood glucose, hydration status and renal function.

For management of a suspected drug overdose, contact your regional Poison Control Centre.

ACTION AND CLINICAL PHARMACOLOGY

Exenatide, a GLP-1 receptor agonist, is a 39 amino acid peptide amide. The amino acid sequence of exenatide partially overlaps that of the endogenous incretin glucagon-like peptide 1 (GLP-1).

BYDUREON BCise is a subcutaneously once-weekly injectable, exenatide extended-release non-aqueous suspension formulation developed as an extension to both the BYETTA exenatide immediate release injection, twice daily (BID) and BYDUREON subcutaneously once-weekly injectable, exenatide extended-release aqueous suspension product lines. BYDUREON BCise contains exenatide extended-release microspheres suspended in an oil-based vehicle of medium chain triglycerides (MCT), and does not require reconstitution.

Mechanism of Action

Incretins, such as GLP-1, enhance glucose-dependent insulin secretion and exhibit other glucoregulatory actions following their release into the circulation from the gut.

Exenatide is a GLP-1 receptor agonist that mimics several antihyperglycemic actions of incretins. Exenatide has been shown to bind to and activate the known human GLP-1 receptor *in vitro*. This leads to an increase in both glucose-dependent synthesis of insulin and *in vivo* secretion of insulin from pancreatic beta cells by mechanisms involving cyclic AMP and/or other intracellular signaling pathways. Exenatide promotes insulin release from pancreatic beta cells in the presence of elevated glucose concentrations. As blood glucose concentrations decrease, insulin secretion subsides.

Pharmacodynamics

Exenatide improves glycemic control by reducing fasting and postprandial glucose concentrations in patients with type 2 diabetes through multiple mechanisms of action. Exenatide enhances glucose-dependent insulin secretion and restores first-phase insulin secretion. Exenatide suppresses glucagon secretion during periods of hyperglycemia in patients with type 2 diabetes. Exenatide also slows gastric emptying. These actions work together to reduce fasting and postprandial glucose concentrations by modulation of both glucose appearance and glucose disposal.

Glucose-dependent insulin secretion: The effect of exenatide infusion on glucose-dependent insulin secretion rate was investigated in 11 healthy subjects. On average, the insulin secretion rate response was glucose-dependent (Figure 1).

Figure 1 Insulin secretion rates (pmol/L/min) by treatment, time, and glycemic condition in healthy subjects (N=11)

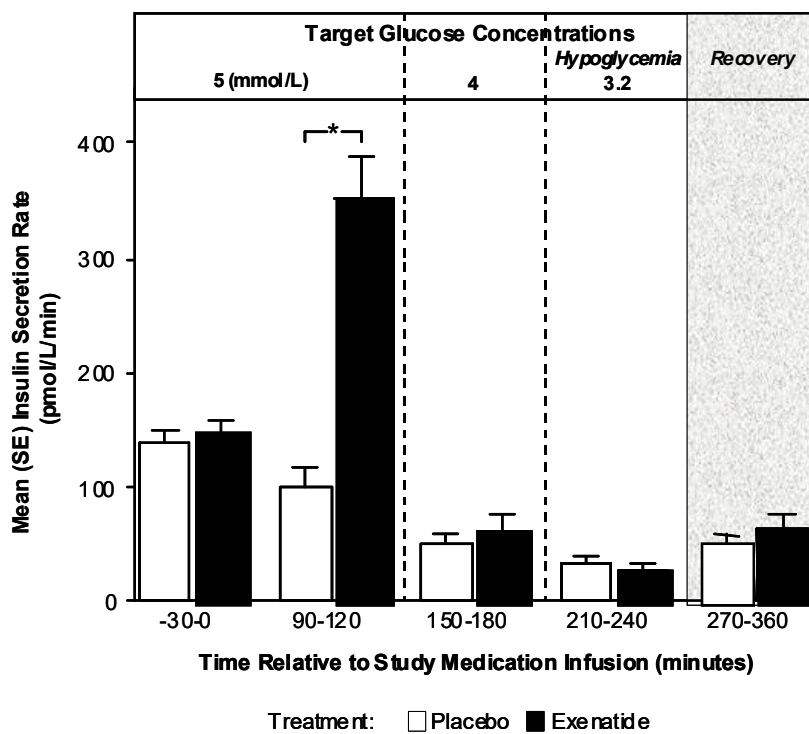

Subjects underwent a stepwise insulin-induced hypoglycemic clamp during IV infusion of exenatide or placebo in a cross-over study design. Study medication infusion was started at time = 0 min. Statistical assessments were for the last 30 min of each glycemic step, during which the target glucose concentrations were maintained. * p<0.05, exenatide treatment relative to placebo. min Minute(s); SE Standard error.

Glucagon secretion: In patients with type 2 diabetes, exenatide moderates glucagon secretion and lowers serum glucagon concentrations during periods of hyperglycemia. Lower glucagon concentrations lead to decreased hepatic glucose output and decreased insulin demand. However, exenatide does not impair the normal glucagon response to hypoglycemia.

Gastric emptying: Exenatide slows gastric emptying thereby reducing the rate at which meal-derived glucose appears in the circulation.

Fasting and Postprandial Glucose: Exenatide improves glycemic control through the immediate and sustained effects of lowering both fasting and postprandial glucose concentrations in patients with type 2 diabetes.

Fasting Glucose

In a 28-week controlled study of exenatide once weekly suspension (BYDUREON BCise) compared to exenatide twice daily (BYETTA), decreases in fasting plasma glucose concentrations were evident following two weeks of therapy, in both treatment groups. At Week 28, the mean change in fasting plasma glucose from baseline was -2.00 mmol/L for BYDUREON BCise and -1.70 mmol/L for BYETTA. The full effect on fasting glucose was not observed until approximately 8 weeks.

In a 12-week repeat dose pharmacokinetic study of exenatide microspheres suspended in MCT-oil in subjects with type 2 diabetes mellitus, reductions in fasting plasma glucose concentrations were seen by Week 4 compared to the placebo group. At the end of Week 12, the mean change in fasting plasma glucose from baseline was -1.8 mmol/L in the exenatide once weekly suspension-treated group compared to 0.4 mmol/L in the placebo group.

Postprandial Glucose

In patients with type 2 diabetes, exenatide reduces postprandial plasma glucose concentrations.

In a 28-week controlled study of exenatide once weekly (BYDUREON BCise) compared to exenatide twice daily (BYETTA), 2-hour postprandial glucose levels were measured during a mixed meal tolerance test in a subset of patients with type 2 diabetes mellitus. Following treatment for 16 weeks, after steady-state concentrations had been achieved, the LS mean change from baseline was greater with BYETTA (-6.31 mmol/L) than BYDUREON BCise (-4.83 mmol/L).

Cardiac Electrophysiology: A randomised, 3-period, placebo- and positive-controlled, double-blind, crossover study was performed to assess the electrophysiological effects of exenatide at therapeutic concentrations on the 12-lead electrocardiogram in healthy subjects (N=74). Exenatide was administered by continuous intravenous infusion at rates selected to maintain plasma concentrations of 200 pg/mL (Day 1), 300 pg/mL (Day 2), and 500 pg/mL (Day 3).

Heart Rate: Exenatide was associated with concentration-related increases in heart rate. All comparisons of change from baseline heart rate between exenatide and placebo were positive on days 1, 2, and 3, with 90% confidence intervals excluding zero. The maximum mean difference from placebo in heart rate was 12.88 bpm (90% CI 11.48, 14.28) on day 1, 14.06 bpm (90% CI 12.74, 15.37) on day 2, and 15.09 bpm (90% CI 13.66, 16.52) on day 3 (see

WARNINGS AND PRECAUTIONS, Cardiovascular and DRUG INTERACTIONS, Drugs that Increase Heart Rate).

PR Interval: Exenatide resulted in prolongation of the heart rate-corrected PR interval (PRc) at all time points on days 1, 2, and 3, with 90% CIs excluding zero at most time points. The maximum mean difference from placebo in PRc was 5.91 ms (90% CI 3.71, 8.12) on day 1, 4.17 ms (90% CI 1.66, 6.68) on day 2, and 6.20 ms (90% CI 3.67, 8.72) on day 3 (see WARNINGS AND PRECAUTIONS, Cardiovascular and DRUG INTERACTIONS, Drugs that Cause PR Interval Prolongation).

QTc Interval: No sustained or concentration-related effect on the QTcP ($QTcP = QT/RR^{0.332}$) interval was observed on days 1 to 3.

Pharmacokinetics

Table 3 Summary Statistics of Exenatide 2 mg Once Weekly (BYDUREON BCise) Pharmacokinetic Parameters at Steady-state in Patients with Type 2 Diabetes Mellitus

Pharmacokinetic Parameters	C_{ssmax} (pg/ml)	T_{ssmax} (h)	AUC_{ss} (pg*h/ml)	C_{ssave} (pg/ml)
Geometric Mean (CV %)	223.3 (29.4)	103.9 (12.5)	31325.7 (3937.4)	186.5 (23.4)

C_{ssmax} Steady-state maximum concentration; T_{ssmax} Time to maximum steady-state concentration; AUC_{ss} Steady-state area under the time-concentration curve during a dosing interval (one week); C_{ssave} Steady-state average concentration; CV Coefficient of variation.

Absorption:

Following a single dose of BYDUREON BCise, there is an initial period of release of surface-bound exenatide followed by a gradual release of exenatide from the microspheres, which results in a peak of exenatide in plasma at weeks 6 to 7 representing the hydration and erosion of the microspheres. Following weekly administration of 2 mg BYDUREON BCise, mean drug concentrations exceeded minimal efficacious concentrations (~ 50 pg/mL) in 2 weeks with gradual increase in the average plasma exenatide concentration up to week 8.

Following initiation of once every 7 days (weekly) administration of 2 mg BYDUREON BCise, gradual increase in the plasma exenatide concentration is observed up to approximately week 8. From week 8 mean exenatide concentrations of approximately 208 pg/mL were maintained over once every 7 days (weekly) dosing intervals indicating that steady state was achieved.

Distribution: The mean apparent volume of distribution of exenatide following subcutaneous administration of a single dose of exenatide 10 µg BID (BYETTA) is 28.3 L.

Metabolism and Elimination: Nonclinical studies have shown that exenatide is predominantly eliminated by glomerular filtration with subsequent proteolytic degradation.

The mean apparent clearance of exenatide in humans is 9.1 L/h and is independent of dose.

Dose proportionality, Accumulation, Time-dependency:

The geometric mean C_{ssave} at steady state for BYDUREON BCise is about 8.6-fold higher than those observed after a single dose. Accumulation occurred gradually over the first 8 weeks of therapy for BYDUREON BCise, after which steady-state concentrations were maintained in the intended therapeutic range.

The exenatide C_{ssave} were comparable up to at least 28 weeks, indicating that exenatide clearance or absorption from BYDUREON BCise did not alter over time.

Special Populations and Conditions

Geriatrics: Population pharmacokinetic analysis of patients (range from 19 to 83 years) suggests that age does not influence the pharmacokinetic properties of exenatide to a clinically meaningful extent.

The exenatide C_{ssave} for 2 mg BYDUREON BCise in patients ≥ 65 years of age was 44% higher than in patients < 65 years of age.

Pediatrics: BYDUREON BCise has not been studied in pediatric patients.

Sex: Population pharmacokinetic analysis of male and female patients suggests that sex has no clinically relevant influence on the steady state concentrations of exenatide. The exenatide C_{ssave} for 2 mg BYDUREON BCise in females was 10.6% higher than in males.

Race: Population pharmacokinetic analysis of patients including Caucasian, non-Caucasian and Asian suggests that race has no significant influence on the pharmacokinetics of exenatide. The exenatide C_{ssave} for 2 mg BYDUREON BCise in Caucasian patients was 3% and 0.6% higher than in non-Caucasian and Asian patients, respectively.

Body Mass Index:

The exenatide C_{ssave} for 2 mg BYDUREON BCise in patients with BMI < 30 kg/m² was 12.8% higher than in patients with BMI ≥ 30 kg/m².

Hepatic Impairment: No pharmacokinetic study has been performed in patients with acute or chronic hepatic insufficiency. Because exenatide is cleared primarily by the kidney, hepatic impairment is not expected to affect blood concentrations of exenatide (see DOSAGE AND ADMINISTRATION and ACTION AND CLINICAL PHARMACOLOGY, Pharmacokinetics, Metabolism and Elimination).

Renal Impairment: BYDUREON BCise has not been studied in patients with severe renal impairment (creatinine clearance < 30 mL/min) or end-stage renal disease (ESRD), including patients on dialysis.

Population pharmacokinetic analysis of renally-impaired patients receiving 2 mg BYDUREON BCise indicate that a 69% and 28% higher systemic exposure to exenatide in moderate (N=24) and mild (N=96) renally-impaired patients, respectively, as compared to patients with normal renal function (N=70).

In a study of BYETTA in subjects with ESRD on dialysis, mean exenatide exposure increased by 3.4-fold compared to that of subjects with normal renal function.

Genetic polymorphism: The influence of genetic polymorphism on the pharmacokinetics of BYDUREON BCise has not been evaluated.

STORAGE AND STABILITY

BYDUREON BCise should be stored in the refrigerator at 2°C to 8°C, up to the expiration date or until preparing for use. BYDUREON BCise can be kept at room temperature (not to exceed 30°C) for no more than a total of 4 weeks, if needed. Store in the original packaging in order to protect from light. BYDUREON BCise must be stored flat.

BYDUREON BCise should not be used past the expiration date. The expiration date for the autoinjector can be found on the carton, or on the autoinjector label.

Keep BYDUREON BCise out of reach of children and pets.

Care should be taken when discarding the BYDUREON BCise autoinjector after use. Place the used autoinjector in a closeable, puncture-resistant sharps container (biohazard container). Discard the sharps container according to the local policies.

SPECIAL HANDLING INSTRUCTIONS

BYDUREON BCise must be removed from the refrigerator 15 minutes before use. The suspension must be mixed by shaking hard for at least 15 seconds, and visually inspected prior to use. The suspension should only be used if it is evenly mixed and cloudy with no white powder seen along the side, bottom or top of the autoinjector window.

BYDUREON BCise must be administered immediately after mixing.

The “Instructions for Use”, which are attached to the PATIENT MEDICATION INFORMATION and also included in the carton, must be carefully followed.

BYDUREON BCise must not be mixed with any other medicinal product.

DOSAGE FORMS, COMPOSITION AND PACKAGING

Dosage Form

BYDUREON BCise is a sterile suspension of 2 mg of exenatide extended-release microspheres in an oil-based vehicle (medium chain triglyceride (MCT)), for once every 7 days (weekly) subcutaneous administration.

Packaging

BYDUREON BCise is supplied in a carton containing:

- 4 single-dose autoinjectors
- Patient Medication Information
- Instructions for use

BYDUREON BCise is supplied as an autoinjector, containing a suspension of exenatide in a MCT diluent vehicle, packaged in a 2-mL glass cartridge. The autoinjector is sealed at one end with a rubber seal/cap combination (combiseal), and at the other end with a rubber plunger. The autoinjector contains an integrated needle (23 gauge, 9/32").

Each autoinjector contains

- 2 mg exenatide (as white to off-white microspheres suspended in a MCT vehicle)
- Sufficient suspension to deliver 2 mg of exenatide extended-release in 0.85 mL vehicle

Composition

Microsphere formulation: Exenatide, poly (D,L-lactide-co-glycolide), sucrose
Vehicle: Medium chain triglycerides (MCT)

PART II: SCIENTIFIC INFORMATION

PHARMACEUTICAL INFORMATION

Drug Substance

Common name: exenatide

Chemical name: Exenatide is a 39-amino acid peptide amide. The amino acid sequence of exenatide is as follows:

H-His-Gly-Glu-Gly-Thr-Phe-Thr-Ser-Asp-Leu-Ser-Lys-Gln-Met-Glu-Glu-Glu-Ala-Val-Arg-Leu-Phe-Ile-Glu-Trp-Leu-Lys-Asn-Gly-Gly-Pro-Ser-Ser-Gly-Ala-Pro-Pro-Pro-Ser-NH₂

Chemical name (USAN):

L-histidylglycyl-L-glutamylglycyl-L-threonyl-L-phenylalanyl-L-threonyl-L-seryl-L-aspartyl-L-leucyl-L-seryl-L-lysyl-L-glutamyl-L-methionyl-L-glutamyl-L-glutamyl-L-glutamyl-L-alanyl-L-valyl-L-arginyl-L-leucyl-L-phenylalanyl-L-isoleucyl-L-glutamyl-L-tryptophanyl-L-leucyl-L-lysyl-L-asparaginylglycylglycyl-L-prolyl-L-seryl-L-serylglycyl-L-alanyl-L-prolyl-L-prolyl-L-prolyl-L-serinamide

Molecular formula and molecular mass: C₁₈₄H₂₈₂N₅₀O₆₀S, 4186.6 Daltons

Structural formula:

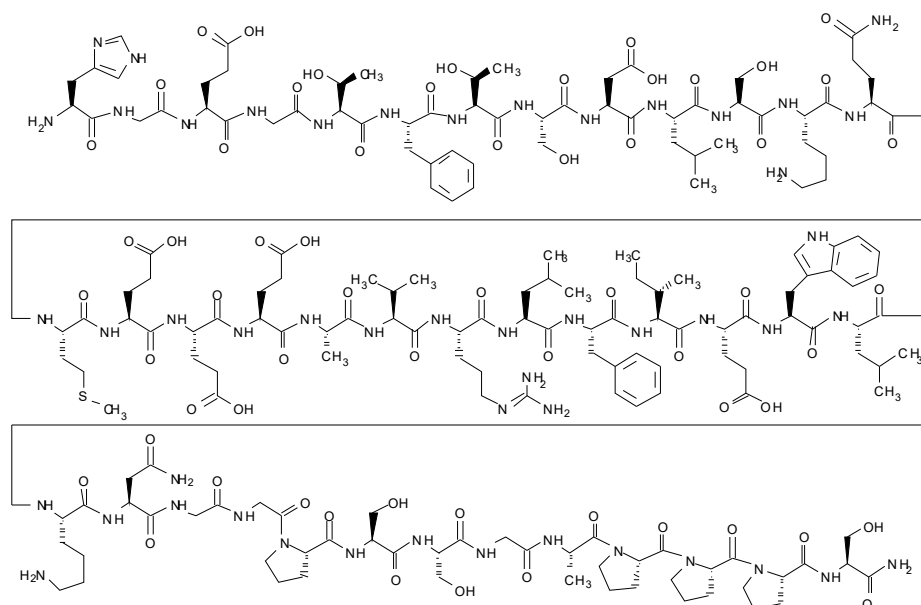

Physicochemical properties: Exenatide drug substance is a white to off-white powder.
Exenatide is freely soluble in water and pH 4.5 acetate buffer.

CLINICAL TRIALS

Study demographics and trial design

Table 4 Summary of patient demographics for clinical trials in specific indication

Trial design and duration	Dosage, route of administration and treatments	Study subjects per treatment arm N=number	Mean age (Range)	Gender (% M/F)
Study BCB118 – 28-week, comparator-controlled study comparing BYDUREON BCise (exenatide once weekly suspension) to BYETTA (exenatide twice daily) in patients who were inadequately treated with diet and exercise alone or with oral antidiabetic therapy, including metformin, a sulfonylurea, a thiazolidinedione, or a combination of any two of these therapies. ¹				
Phase 3, multicenter, randomized, open-label, parallel group, 28-week, comparator-controlled study, followed by 24-week uncontrolled extension.	<ul style="list-style-type: none"> BYDUREON BCise 2 mg QW SC 	BYDUREON BCise QW N=229	56 years (26-80)	64/36
	<ul style="list-style-type: none"> Byetta 5 µg BID for 4 weeks, then Byetta 10 µg BID for 24 weeks 	Byetta N=146		
	Subjects were randomized in a 3:2 ratio to receive BYDUREON BCise 2 mg QW SC or BYETTA, in addition to existing oral antidiabetic agents. Extension: <ul style="list-style-type: none"> BYDUREON BCise 2 mg QW SC 	BYDUREON BCise QW N=309		
Study BCB120 – 28-week, comparator-and placebo-controlled study comparing BYDUREON BCise (exenatide once weekly suspension) to sitagliptin and placebo in patients inadequately treated with metformin. ²				
Phase 3, randomized, open-label, 28-week, comparator- and placebo-controlled study.	<ul style="list-style-type: none"> BYDUREON BCise 2 mg QW SC 	BYDUREON BCise QW N=181	53 years (29-76)	53/47
	<ul style="list-style-type: none"> Sitagliptin 100 mg/day 	Sitagliptin N=122		
	<ul style="list-style-type: none"> Placebo Subjects were randomized to receive either BYDUREON BCise 2 mg QW SC, sitagliptin, or placebo in a ratio of 3:2:1. Subjects continued their existing metformin treatment (≥ 1500 mg metformin daily).	Placebo N=61		

BID Twice daily; QW Once Weekly, SC subcutaneous

Study Results

Comparator-Controlled Clinical Trials

BYDUREON BCise was studied as monotherapy and in combination with metformin, a sulfonylurea, a thiazolidinedione, or a combination of any two of these therapies.

BYDUREON BCise vs. BYETTA as Add-On to Diet and Exercise Alone or in Combination with one or any two of Metformin, Sulfonylurea, or Thiazolidinedione (Study BCB118)

A 28-week, randomized open-label comparator-controlled trial with a 24-week open-ended extension period, compared BYDUREON BCise (n=229) to BYETTA (n=148). The majority of the patients in the study were Caucasian (74%, n=278), followed by Black or African American (16%, n=61), Asian (7%, n= 25), other (1%, n=5), American Indian or Alaska Native (1%, n=5), and Native Hawaiian or Other Pacific Islander (<1%, n=1).

Patients were treated with diet and exercise alone (13%), a single oral antidiabetic agent (49%), or combination therapy of oral antidiabetic agents (38%). The mean baseline HbA1c was 8.5%. Patients were randomly assigned to receive BYDUREON BCise 2 mg once every 7 days (weekly) or BYETTA (10 mcg twice daily), in addition to existing oral antidiabetic agents. Patients assigned to BYETTA initiated treatment with 5 mcg twice daily then increased the dose to 10 mcg twice daily after 4 weeks.

The primary endpoint was change in HbA1c from baseline to Week 28. Treatment with BYDUREON BCise achieved a statistically significantly larger reduction in HbA1c, compared to BYETTA (see Table 5).

Table 5 Results of 28-week trial of BYDUREON BCise versus BYETTA, both as monotherapy or as add-on to metformin, a sulfonylurea, a thiazolidinedione, or combination of oral agents (Modified intent-to-treat patients)

	BYDUREON BCise 2 mg QW	BYETTA 10 µg BID
N	229	146
HbA1c (%)		
Mean baseline	8.5	8.5
Mean change from baseline at week 28 ¹	-1.4	-1.0
Mean difference from BYETTA (95% CI) [†]	-0.37 (-0.63, -0.10)*	
Patients (%) achieving HbA1c <7% at Week 28²	49	43
Fasting plasma glucose (mmol/L)		
Mean baseline	10	10
Mean change from baseline at week 28 ¹	-1.8	-1.3
Body weight (kg)		
Mean baseline	97.2	96.6

	BYDUREON BCise 2 mg QW	BYETTA 10 µg BID
N	229	146
Mean change from baseline at week 28 ¹	-1.5	-1.9

N = number of patients in each treatment group, CI = unadjusted confidence interval, QW = once weekly.

*p-value <0.01.

[†]The non-inferiority margin was set at +0.4% in this study.

¹ Least squares means were obtained using a mixed model repeated measure analysis with treatment, diabetes management method at Screening (diet/exercise alone, SU use, or non-SU use), renal function (normal, mild renal impairment, or moderate renal impairment), week of visit, treatment-by-visit interaction, and HbA1c stratum (<9% or ≥9%) at Screening as fixed factors, and subject as random effect.

² Subjects with missing values at Week 28 counted as not achieving goal.

BYDUREON BCise versus Sitagliptin and Placebo, All as Add-on to Metformin Therapy (Study BCB120)

A 28-week open-label (oral medication blinded), comparator- and placebo-controlled trial, compared the safety and efficacy of BYDUREON BCise to sitagliptin and placebo. A total of 364 patients were studied, 296 (81%) were Caucasian, 49 (14%) Black or African American, 14 (4%) Asian, and 3(<1%) American Indian or Alaska Native, 1(<1%) Native Hawaiian or Other Pacific Islander and 1(<1%) was classified otherwise.

The mean baseline HbA1c was 8.5%. Patients were randomly assigned to receive BYDUREON BCise 2 mg once every 7 days (weekly), sitagliptin 100 mg/day or placebo (tablet), in addition to their existing metformin therapy.

The primary endpoint was change in HbA1c from baseline to week 28. Treatment with BYDUREON BCise 2 mg once weekly resulted in a statistically significant mean reduction in HbA1c compared to sitagliptin 100 mg/day and placebo (see Table 6).

Table 6 Results of 28-week trial of BYDUREON BCise versus Sitagliptin and Placebo, all as add-on to metformin therapy (Modified intent-to treat patients)

	BYDUREON BCise 2 mg QW	Sitagliptin 100 mg/day	Placebo Once Daily
N	181	122	61
HbA1c (%)			
Mean baseline	8.4	8.5	8.5
Mean change at week 28 ¹	-1.1	-0.8	-0.4
Difference from sitagliptin (95% CI) ^{1†}	-0.38 (-0.70, -0.06)*		

	BYDUREON BCise 2 mg QW	Sitagliptin 100 mg/day	Placebo Once Daily
N	181	122	61
HbA1c (%)			
Difference from placebo (95% CI) ¹	-0.72 (-1.15,-0.30)**		
Patients (%) achieving HbA1c <7% at Week 28²	43	32	25
Fasting plasma glucose (mmol/L)			
Mean baseline	9.9	9.8	9.6
Mean change from baseline at week 28 ¹	-1.2	-0.6	0.5
Body weight (kg)			
Mean baseline	89.2	88.1	89.0
Mean change from baseline at week 28 ¹	-1.1	-1.2	0.2

N = number of patients in each treatment group, CI = unadjusted confidence interval, QW = once weekly.

*p-value <0.05, **p-value <0.01.

†Sitagliptin 100 mg/day did not show superiority to placebo in this study.

¹ Least squares means were obtained using a mixed model repeated measure analysis with treatment, week of visit, treatment by week interaction, baseline HbA1c stratum (<9% or ≥9%) and baseline HbA1c stratum by week interaction as fixed factors, and subject as random effect. Baseline HbA1c and baseline HbA1c by week interaction were also included as covariates.

² Subjects with missing values at Week 28 counted as not achieving goal.

DETAILED PHARMACOLOGY

Exenatide is a 39-amino acid peptide amide that exhibits approximately 50% sequence identity with that of the mammalian endogenous incretin glucagon-like peptide-1 (GLP-1) secreted in response to a meal by intestinal L-cells.³ *In vitro* pharmacology studies have shown that exenatide can bind and activate the human GLP-1 receptor leading to an increase in both synthesis and secretion of insulin from pancreatic beta-cells.⁴ *In vitro* studies have also demonstrated that exenatide is not substantially degraded by the protease dipeptidyl peptidase-4 (DPP-4), which explains the longer duration of pharmacologic effects observed with exenatide, when compared to native GLP-1.

Nonclinical Pharmacodynamics

Nonclinical pharmacology studies support the concept that exenatide is a GLP-1 receptor agonist that acts through multiple mechanisms to promote lowering of plasma glucose concentrations and to lower HbA1c. Exenatide decreases fasting glucose concentrations in animal models of type 2 diabetes (rat, mouse, and monkey) and exhibits a durable effect to lower HbA1c in diabetic mice and rats.⁵ Beneficial actions of exenatide on glucose and HbA1c were consistent, whether dosed twice-daily with exenatide or dosed once over 4 weeks with exenatide extended-release in ZDF rats.^{5,6} Improvements in glycemic control are achieved via modulation of both the rate of glucose

appearance in the circulation (slowing of gastric emptying, reduced food intake, and suppression of inappropriately elevated glucagon secretion) and the rate of glucose clearance (enhanced glucose-dependent insulin secretion, improved insulin sensitivity, and increased beta-cell mass). Reduced food intake in animal models of type 2 diabetes was associated with reduced weight gain.⁷

Nonclinical Pharmacokinetics

Exenatide was absorbed over an extended period of time following a subcutaneous injection of exenatide extended-release (BYDUREON), with a relative bioavailability compared to exenatide twice daily (BYETTA) calculated to be approximately 63% in rat and 23% in monkey.

PK parameters for exenatide from BYDUREON BCise were determined in both the rat and monkey and showed, like BYDUREON, that exenatide is absorbed over an extended period of time following a SC injection with BYDUREON BCise. With the exception of the initial release of exenatide in the first few days following injection, the serum concentration time profile of BYDUREON BCise and PK parameters of BYDUREON BCise were similar to those observed for BYDUREON. Treatment-emergent antibodies to exenatide developed over time in both rats and monkeys and impacted the measured plasma concentrations. Exenatide was eliminated primarily by the kidney. Studies performed in rats, mice, rabbits, and humans to evaluate the potential for exenatide to cross the placental barrier provide support that the fetal to maternal ratio is low.

Clinical Pharmacodynamics

BYDUREON BCise treatment resulted in a mean reduction in fasting glucose following two weeks of therapy, with full effect seen in 8 weeks. Data from a mixed meal tolerance test in a subset of patients with type 2 diabetes showed a mean change from baseline in 2 hour postprandial plasma glucose of -4.8 mmol/L following 16 weeks of BYDUREON BCise treatment.

Clinical Pharmacokinetics

There is an initial release of exenatide within hours following a single 10 mg subcutaneous dose of BYDUREON BCise, followed by a gradual release of exenatide from the microspheres resulting in a peak of exenatide at weeks 6 to 7. Accumulation occurs gradually over the first 8 weeks of once weekly administration, after which steady state is achieved with an 8.6-fold accumulation of exenatide C_{ssave} compared to the first dose.

The mean apparent volume of distribution of exenatide following subcutaneous administration of a single dose of exenatide 10 µg BID (BYETTA) is 28.3 L. Exenatide is primarily cleared via passive renal mechanisms. The mean apparent clearance of exenatide in humans is 9.1 L/h. Exenatide extended-release (BYDUREON) has no clinically significant effect on acetaminophen pharmacokinetics.

Safety Pharmacology

Safety pharmacology studies examined exenatide-related cardiovascular, renal, nervous, and endocrine system effects. Exenatide produced acute, dose-dependent hemodynamic effects including increases in mean arterial blood pressure and heart rate in rats. These effects appeared

to be transient and were not observed in other species. Exenatide at nominal concentrations of 5.9 and 91.1 μM did not affect hERG currents in HEK293 cells stably transfected with hERG DNA (N=3/treatment). No differences from vehicle in heart rate or electrocardiogram changes were detected in an escalating dose cardiovascular safety pharmacology study performed in free-moving conscious telemetry monkeys (N=3), receiving single subcutaneous doses of 30, 300, and 1000 $\mu\text{g}/\text{kg}$ exenatide. Exenatide produced an acute, profound diuresis and natriuresis in rats, and a mild diuresis in mice. No exenatide-related effects on renal function were detected in monkeys.

TOXICOLOGY

Acute Toxicity

Single-dose toxicity studies were conducted with exenatide in mice, rats, and monkeys. No lethality or serious toxicity was observed in mice, rats, or monkeys at doses up to 1500 $\mu\text{g}/\text{kg}$ (intravenous), 30,000 $\mu\text{g}/\text{kg}$ (subcutaneous), or 5000 $\mu\text{g}/\text{kg}$ (subcutaneous) respectively.

Repeat-Dose Toxicity

Repeat-dose toxicity studies were conducted with exenatide extended-release (BYDUREON) in rats and monkeys. Decreased body weight gain and food consumption, a known pharmacologic effect of exenatide, were observed in rats. Reversible, dose-related injection site reactions (erythema, swelling, inflammation, thickening, and granulomas associated with the presence of microspheres) were observed in placebo microsphere- and exenatide-treated groups in both species. No target organ toxicities occurred in rats or monkeys at subcutaneous doses up to 9 mg/kg Q2W (18 weeks) or 1.1 mg/kg Q1W (39 weeks), respectively, with corresponding systemic exposures of up to 27 and 14 times the human exposure resulting from the recommended dose of 2 mg/week based on plasma area under the curve (AUC), respectively.

Repeat-dose toxicity studies were conducted with exenatide in mice, rats, and monkeys. Decreased body weight gain and food consumption, a known pharmacologic effect of exenatide, were observed in all repeat-dose toxicity studies. No target organ toxicities occurred in mice, rats, or monkeys at subcutaneous doses up to 760 $\mu\text{g}/\text{kg}/\text{day}$ (182 days), 250 $\mu\text{g}/\text{kg}/\text{day}$ (91 days), or 150 $\mu\text{g}/\text{kg}/\text{day}$ (273 days), respectively, with corresponding systemic exposures of up to 157, 37, and 183 times the human exposure resulting from the recommended dose of 2 mg/week based on AUC, respectively.

Repeat-dose toxicity studies were conducted with BYDUREON BCise in cynomolgus monkeys (in 1 and 3 month studies). In the 1 month study, once weekly subcutaneous dosing of up to 1.1 mg/kg/dose was well tolerated, with no adverse systemic toxicity observed, corresponding to 4.2 times the human systemic exposure, based on AUC. In the 3 month study, once weekly subcutaneous dosing of up to 1.1 mg/kg/dose was well tolerated, with no adverse systemic toxicity observed, corresponding to 20 times the human systemic exposure, based on AUC.

Carcinogenicity

A 104-week carcinogenicity study was conducted with exenatide extended-release (BYDUREON) in male and female rats at doses of 0.3, 1.0 and 3.0 mg/kg (2, 9, and 26-times

human systemic exposure based on AUC, respectively) administered by subcutaneous injection every other week. A statistically significant increase in thyroid C-cell tumour incidence was observed in both males and females. The incidence of C-cell adenomas was statistically significantly increased at all doses (27% to 31%) in females and at 1.0 and 3.0 mg/kg (46% and 47%, respectively) in males compared with the control group (13% for males and 7% for females). A statistically significantly higher incidence of C-cell carcinomas occurred in the high dose group females (6%), while numerically higher incidences of 3%, 7%, and 4% (non-statistically significant versus controls) were noted in the low, mid, and high dose group males compared with the control group (0% for both males and females). An increase in benign fibromas was seen in the skin subcutis at injection sites of males given 3 mg/kg. No treatment-related injection site fibrosarcomas were observed at any dose. The no-observed-adverse-effect level (NOAEL) for carcinogenicity was less than 0.3 mg/kg (<2 times human exposure resulting from the recommended dose of 2 mg/week, based on AUC).

A 104-week carcinogenicity study was conducted with exenatide in male and female rats at doses of 18, 70, or 250 µg/kg/day administered by bolus subcutaneous injection. An apparent numerical increase in benign thyroid C-cell adenomas was observed in female rats given the high dose of 250 µg/kg/day. This dose has a systemic exposure 37 times the human exposure resulting from the recommended dose of 2 mg/week, based on AUC. This increased incidence was not statistically significant when adjusted for survival. There was no tumourigenic response in male rats.

In a 104-week carcinogenicity study conducted with exenatide in mice at doses of 18, 70, or 250 µg/kg/day administered by bolus subcutaneous injection, no evidence of tumours was observed at doses up to 250 µg/kg/day, a systemic exposure up to 23 times the human exposure resulting from the recommended dose of 2 mg/week, based on AUC.

Mutagenicity

Exenatide and exenatide extended-release (BYDUREON) were not mutagenic or clastogenic, with or without metabolic activation, in the Ames bacterial mutagenicity assay or chromosomal aberration assay in Chinese hamster ovary cells. Exenatide was negative in the *in vivo* mouse micronucleus assay.

Reproduction

In mouse fertility studies with subcutaneous doses of 6, 68 or 760 µg/kg/day exenatide, males were treated for 4 weeks prior to and throughout mating and females were treated 2 weeks prior to and throughout mating until Gestation Day 7. No adverse effect on fertility was observed at 760 µg/kg/day, a systemic exposure 148 times the human exposure resulting from the recommended dose of 2 mg/week, based on AUC.

Development

Fetuses from pregnant rats given subcutaneous doses of exenatide extended-release (BYDUREON) at 0.3, 1 or 3 mg/kg on gestation days 6, 9, 12 and 15 demonstrated reduced fetal growth at all doses and produced skeletal ossification deficits at 1 and 3 mg/kg in association with maternal effects (decreased food intake and decreased body weight gain). There was no evidence of malformations. Doses of 0.3, 1 and 3 mg/kg correspond to systemic exposures of 3, 7 and 17-

times, respectively, the human exposure resulting from the recommended dose of 2 mg/week, based on AUC. Both the maternal and developmental NOAELs for exenatide extended-release in rats were less than 0.3 mg/kg. For BYDUREON BCise, doses of 0.3, 1 and 3 mg/kg correspond to systemic exposures of 2.8, 7.9, and 18.5 times respectively, the human exposure resulting from recommended dose of 2 mg/week based on AUC.

In pregnant mice given subcutaneous doses of 6, 68, 460, or 760 µg/kg/day exenatide from Gestation Day 6 through 15 (organogenesis), fetal growth was slowed at doses ≥ 68 µg/kg/day exenatide. Administration of higher doses of exenatide (≥ 460 µg/kg/day) was associated with skeletal effects known to be associated with slowed fetal growth. The NOAEL for developmental effects in mice was 6 µg/kg/day (1.2 times the human exposure resulting from the recommended dose of 2 mg/week, based on AUC). Systemic exposures were equivalent to the human exposure resulting from the recommended dose of 2 mg/week, based on AUC, for BYDUREON BCise.

In pregnant rabbits given subcutaneous doses of 0.2, 2, 22, 156, or 260 µg/kg/day exenatide from Gestation Day 6 through 18 (organogenesis), fetal growth was slowed at doses greater than or equal to 22 µg/kg/day. The NOAEL for developmental effects in rabbits was 2 µg/kg/day (4.8 times the human exposure resulting from the recommended dose of 2 mg/week, based on AUC).

In pregnant mice given subcutaneous doses of 6, 68, or 760 µg/kg/day exenatide from Gestation Day 6 through Lactation Day 20 (weaning), slowed neonatal growth was observed in the F1 offspring at doses ≥ 68 µg/kg/day. Increased perinatal and neonatal mortality occurred in the F1 offspring at 760 µg/kg/day. The NOAEL for developmental toxicity in mice was 6 µg/kg/day (1.2 times the human exposure resulting from the recommended dose of 2 mg/week, based on AUC).

REFERENCES

1. Wysham CH, Rosenstock J, Vetter ML, Dong F, Ohman P, Iqbal N. Efficacy and tolerability of the new autoinjected suspension of exenatide once weekly versus exenatide twice daily in patients with type 2 diabetes. *Diabetes, Obesity and Metabolism* 2018; 20:165–172
2. Gadde KM, Vetter ML, Iqbal N, Hardy E, Ohman P. Efficacy and safety of autoinjected exenatide once-weekly suspension versus sitagliptin or placebo with metformin in patients with type 2 diabetes: The DURATION-NEO-2 randomized clinical study. *Diabetes, Obesity and Metabolism* 2017; 19: 979 -988.
3. Eng J, Kleinman WA, Singh L, Singh G, Raufman JP. Isolation and characterization of exendin-4, an exendin-3 analogue from *Heloderma suspectum* venom. *J Biol Chem.* 1992; 267:7402-7405.
4. Goke R, Fehmann HC, Linn T, Schmidt H, Krause M, Eng J, Goke B. Exendin-4 is a high potency agonist and truncated exendin-(9-39)-amide an antagonist at the glucagon-like peptide-1-(7-36) amide receptor of insulin-secreting beta-cells. *J Biol Chem.* 1993; 268:19650-19655.
5. Parkes DG, Mace KF, Tratmann ME. Discovery and development of exenatide: the first antidiabetic agent to leverage the multiple benefits of the incretin hormone, GLP-1. *Expert Opin. Drug Discov.* 2013; 8(2):219-244.
6. Gedulin, BR, Nikoulina SE, Smith PA, Gedulin G, Neilsen GL, Baron AD, Parkes DG, Young AA. Exenatide (Exendin-4) Improves Insulin Sensitivity and β -Cell Mass in Insulin-Resistant Obese fa/fa Zucker Rats Independent of Glycemia and Body Weight. *Endocrinology* 2005; 146(4):2069–2076.
7. Szayna M, Doyle ME, Betkey JA, Holloway HW, Spencer RGS, Greig NH, Egan JM. Exendin-4 decelerates food intake, weight gain, and fat deposition in Zucker rats. *Endocrinology.* 2000; 141:1936-1941.

**READ THIS FOR SAFE AND EFFECTIVE USE OF YOUR MEDICINE
PATIENT MEDICATION INFORMATION**

**BYDUREON® BCise™
exenatide extended-release injectable suspension**

Read this carefully before you start taking **BYDUREON BCise** and each time you get a refill. This leaflet is a summary and will not tell you everything about this drug. Talk to your healthcare professional about your medical condition and treatment and ask if there is any new information about **BYDUREON BCise**.

Serious Warnings and Precautions

Do NOT use BYDUREON BCise if you:

- or a family member has ever had medullary **thyroid** cancer (MTC).
- have Multiple Endocrine Neoplasia syndrome type 2 (MEN 2). This is a disease where people have tumours in more than one gland in their body.

In rats, extended-release exenatide causes a higher rate of thyroid tumours. It is not known if BYDUREON BCise causes thyroid tumours, including MTC, in people.

What is BYDUREON BCise used for?

BYDUREON BCise along with diet and exercise is used to improve control of blood sugar levels in adults with type 2 diabetes.

BYDUREON BCise can be used:

- alone, if you cannot take metformin,
OR
- in combination with these drugs. The combination is used when these drugs no longer provide enough control of blood sugar levels on their own.
 - metformin
 - a sulfonylurea (SU)
 - or metformin and a SU

How does BYDUREON BCise work?

BYDUREON BCise helps your body release more insulin when your blood sugar is high. This helps to improve your blood sugar control.

What are the ingredients in BYDUREON BCise?

Medicinal ingredients: extended-release exenatide

Non-medicinal ingredients: poly (D,L-lactide-co-glycolide), medium chain triglycerides (MCT), sucrose

BYDUREON BCise is supplied in a carton containing:

- 4 single dose autoinjectors
- Patient Medication Information
- Instructions for Use

Each autoinjector contains:

- 2 mg exenatide (as white to off-white microspheres suspended in a MCT vehicle)
- Sufficient suspension to deliver 2 mg of exenatide extended-release in 0.85 mL vehicle

Do not use BYDUREON BCise if you:

- are allergic to exenatide or to any of the ingredients in this drug.
- have severe kidney disease or are on dialysis.
- have diabetic ketoacidosis. This is an accumulation of ketones in the blood and urine.
- have type 1 diabetes.
- are pregnant or planning to have a baby. It is not known if BYDUREON BCise will harm your unborn baby. Women who can have children should use effective means of birth control while they are taking BYDUREON BCise. BYDUREON BCise should be stopped at least 3 months before planning to become pregnant.
- are under 18 years old.

To help avoid side effects and ensure proper use, talk to your healthcare professional before you take BYDUREON BCise. Talk about any health conditions or problems you may have, including if you:

- are taking other drugs to control blood sugar including insulin.
- are taking a blood thinner such as warfarin.
- have a high heart rate (fast pulse).
- have any heart disease, such as angina, history of a heart attack, or heart rhythm disturbances.
- have a condition called heart block.
- are receiving treatment with a sulfonylurea (SU). Examples are glyburide, gliclazide, glimepride. These types of drugs can increase the risk of having low blood sugar if used in combination with BYDUREON BCise.
- have severe problems with your stomach (gastroparesis) or food digestion.
- have severe vomiting and/or diarrhea and/or dehydration.
- have a history of problems with your pancreas, stones in your gallbladder (gallstones), alcohol abuse, or high levels of fat in your blood.
- have kidney problems or a kidney transplant.
- are breast feeding or plan to breastfeed. It is not known if BYDUREON BCise passes into breast milk.
- are over 65 years old.

Other warnings you should know about:

When using BYDUREON BCise with a sulfonylurea (SU) take precautions to avoid having low blood sugar while driving or using machines.

Tell your healthcare professional about all the medicines you take, including any drugs, vitamins, minerals, natural supplements or alternative medicines.

The following may interact with BYDUREON BCise:

- a sulfonylurea (SU) such as glyburide, gliclazide, glimepiride. Taking BYDUREON BCise with an SU can make your blood sugar too low.
- certain other kinds of drugs used to control blood sugar, including all drugs that contain exenatide.
- drugs that increase heart rate or that affect your heart rhythm.
- other drugs taken by mouth.
- a birth control pill (oral contraceptive).
- blood thinner (warfarin).
- heart medication (digoxin).
- blood pressure medication (lisinopril).
- cholesterol medication (lovastatin).

How to take BYDUREON BCise:

Your doctor or pharmacist should give you training before you inject BYDUREON BCise. You should also read the “Instructions for Use” included at the end of this Patient Medication Information. A copy of the “Instructions for Use” is also included in the product packaging. These instructions will give you details on how to use and inject BYDUREON BCise.

Use BYDUREON BCise exactly as instructed by your doctor. Never take more than the dose your doctor has told you to use.

For subcutaneous use only. BYDUREON BCise is to be injected under the skin (subcutaneous injection) of your stomach area (abdomen), upper leg (thigh), or upper arm. If you inject in the same body part, you should choose a different spot each week.

Look at the solution prior to using BYDUREON BCise. The solution should be cloudy and evenly mixed, and not have any white medicine visible on the bottom, top, or sides of the autoinjector window. After BYDUREON BCise is evenly suspended in the diluent, it should be injected right away.

BYDUREON BCise must not be injected into a vein or muscle.

Do not share BYDUREON BCise with another person.

Do not mix BYDUREON BCise with any other medicines.

If you stop taking BYDUREON BCise, tell your healthcare professional. Do not start taking other drugs, vitamins, mineral supplements or alternative medicines on your own. This includes other drugs to treat diabetes. BYDUREON BCise drug levels, effects and side effects will slowly go down in your body. This continues for about 10 weeks after you stop using it.

Recommended Adult dose:

2 mg subcutaneous injection once every seven days. The dose can be administered at any time of day, with or without meals.

When you first take BYDUREON BCise with a sulfonylurea (SU), your doctor might lower the dose of the SU.

Overdose:

Too much BYDUREON BCise may give you nausea, vomiting or make you feel like you have low blood sugar.

If you think you have taken too much BYDUREON BCise, contact your healthcare professional, hospital emergency department or regional Poison Control Centre immediately, even if there are no symptoms.

Missed Dose:

If you miss a dose of BYDUREON BCise, you should take it as soon as you remember if it is within 3 days after the missed dose. You can take your next dose at your usual weekly time.

If it has been longer than 3 days after the missed dose, skip the dose and wait to take BYDUREON BCise at your next usual weekly time. Do not take an extra dose of BYDUREON BCise to make up for your missed dose.

What are possible side effects from using BYDUREON BCise?

These are not all the possible side effects you may feel when taking BYDUREON BCise. If you experience any side effects not listed here, contact your healthcare professional. Please also see the Serious Warnings and Precautions box.

Side effects may include:

- nausea
- diarrhea
- vomiting
- injection site reactions such as lumps and itchy skin
- headache

Serious side effects and what to do about them			
Symptom/effect	Talk to your healthcare professional		Stop taking drug and get immediate medical help
	Only if severe	In all cases	
COMMON			
Hypoglycemia (low blood sugar) especially if you are also taking an SU. You may have headaches, feel sleepy, weak, dizzy, confused, hungry, jittery, or sweaty. Feel like your heart is beating fast.	✓		
UNCOMMON			
Pancreatitis (swelling of the pancreas): long periods of pain in the stomach and/or intestine area which may go around to your back. You may also vomit.			✓
Dehydration. (It can be from nausea, vomiting and/or diarrhea, or not taking enough liquids by mouth): If this happens while on BYDUREON BCise it may cause new or worsening problems with kidney function. This includes kidney failure.	✓		
Increase heart rate or changes in heart rhythm: dizziness, fainting. Feel a rapid, pounding, or irregular heartbeat. This is more likely if you, have heart disease, take certain other drugs, or are more than 65 years old.		✓	
Injection Site Reactions: Swelling, hardness, itching, redness, dark discoloration or bruising. This can be with or without lumps under the skin. There can be intense pain, pus, or an open wound, fever and fatigue. Surgery may be required.	✓		

Serious side effects and what to do about them			
Symptom/effect	Talk to your healthcare professional		Stop taking drug and get immediate medical help
	Only if severe	In all cases	
RARE			
Angioedema or Severe Allergic Reactions, including Anaphylaxis: severe rash, hives, or itching. Sudden swelling of the face, lips, tongue or throat. Difficulty breathing or swallowing. Fainting and a very fast heartbeat.			✓
Kidney Disorders: nausea, vomiting, diarrhea. Muscle cramps. Swelling of the legs, ankles, feet, face and/or hands. Shortness of breath due to extra fluid on the lungs. More frequent urination, or in greater amounts than usual, with pale urine. Or, less frequent urination, or in smaller amounts than usual, with dark coloured urine.			✓
Thyroid Cancer: a lump or swelling in your neck, hoarseness, or trouble swallowing.		✓	

If you have a troublesome symptom or side effect that is not listed here or becomes bad enough to interfere with your daily activities, talk to your healthcare professional.

Reporting Side Effects

You can report any suspected side effects associated with the use of health products to Health Canada by:

- Visiting the Web page on Adverse Reaction Reporting (<http://www.hc-sc.gc.ca/dhp-mps/medeff/report-declaration/index-eng.php>) for information on how to report online, by mail or by fax; or
- Calling toll-free at 1-866-234-2345.

NOTE: Contact your health professional if you need information about how to manage your side effects. The Canada Vigilance Program does not provide medical advice.

Storage:

- Store BYDUREON BCise flat in a refrigerator at 2°C to 8°C.
- Store BYDUREON BCise in the original packaging in order to protect from light.
- BYDUREON BCise can be stored at room temperature up to 30°C for 4 weeks if required.
- BYDUREON BCise should not be used after the expiration date printed on the product packaging (carton and autoinjector).
- BYDUREON BCise must be discarded after use in a puncture-resistant container.
- Keep BYDUREON BCise out of reach and sight of children and pets.

If you want more information about BYDUREON BCise:

- Talk to your healthcare professional
- Find the current full Product Monograph that is prepared for healthcare professionals and includes the current Patient Medication Information and Instructions for Use by visiting the [Health Canada website](http://hc-sc.gc.ca/index-eng.php) (<http://hc-sc.gc.ca/index-eng.php>); the AstraZeneca website: www.astrazeneca.ca, or by calling AstraZeneca Canada Inc. at:
1-800-668-6000 (Questions or concerns)
1-800-461-3787 (Des questions ou préoccupations?).

NOTE: This PATIENT MEDICATION INFORMATION leaflet provides you with the most current information at the time of printing.

This leaflet was prepared by AstraZeneca Canada Inc., Mississauga, Ontario L4Y 1M4.

BYDUREON[®] is a registered trademark of Amylin Pharmaceuticals LLC used under license by AstraZeneca Canada.

BCise[™] is a trademark of AstraZeneca Pharmaceuticals LP, used with permission by AstraZeneca Canada Inc.

© AstraZeneca 2018

Date of Revision: November 23, 2018

Important Instructions for Use, read carefully

How to use ^PBYDUREON[®] BCise[™] exenatide extended-release injectable suspension

For subcutaneous use only

Single-dose Autoinjector once weekly



Prior to using Bydureon BCise you should be trained on its proper use by a healthcare professional.

Read these instructions before you start using Bydureon BCise and each time you get a refill. There may be new information. This information does not take the place of talking to your healthcare provider about your medical condition or your treatment. Unless a trained person can help, Bydureon BCise is not recommended for people who are blind or cannot see well.

Before You Begin

The BYDUREON BCise autoinjector:

- Is a single use, fixed dose autoinjector that automatically injects your medicine.
- Comes in the locked position before you use it. Do not unlock the autoinjector until you are ready to inject it.
- Needle is hidden. You do not see it before, during, or after using the autoinjector.
- **Do not** use the autoinjector if any parts look to be broken or damaged.
- Store flat in the refrigerator between 2°C to 8°C.
- Never share your Bydureon BCise autoinjector with anyone else. You may give an infection to them or get an infection from them.
- Bydureon BCise should **not** be used by people who are blind or cannot see well, unless another person who is trained to use this device can help.
- Keep the autoinjector, and all medicines, out of the reach of children.

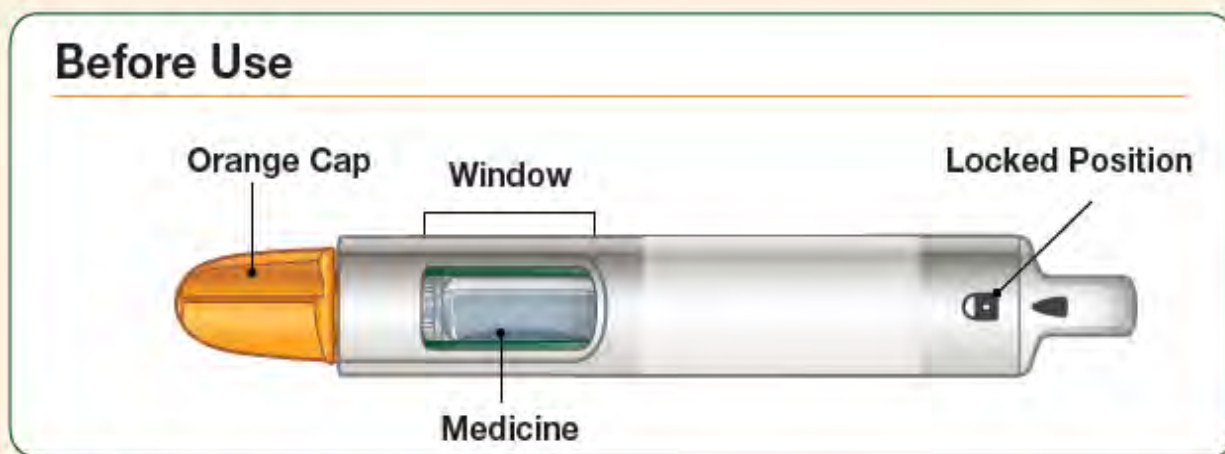

Figure A

Supplies needed to give your injection:

- Bydureon BCise autoinjector
- Alcohol swab
- A clean, flat surface
- Sharps container (see “disposal” instructions at the end of these instructions)

STEP 1: Prepare for Injection

A. Let your BYDUREON BCise autoinjector come to room temperature.

Remove 1 autoinjector from the refrigerator and rest it flat for 15 minutes.

Autoinjector can be kept at room temperature for up to 4 weeks.



Figure B

B. Check the expiration date (labeled EXP) printed on the autoinjector label.

Do not use the autoinjector past the expiration date.



Figure C

C. Wash your hands.

D. Choose your injection site.

In either your stomach, thigh, or back of the upper arm, see Figure D.

Each week you can use the same area of your body, but choose a different injection site in that area of your body.

Clean the area with an alcohol swab.

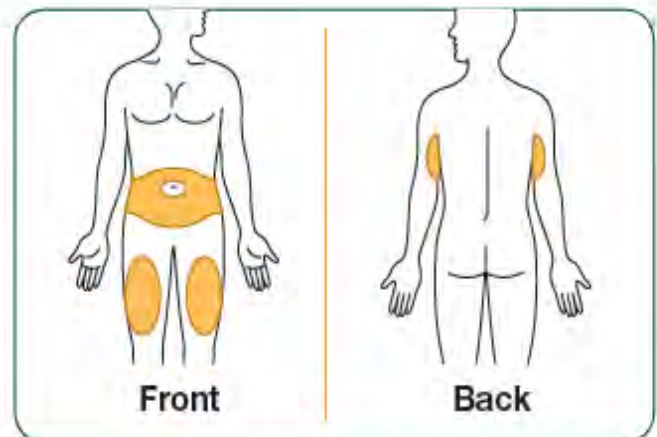

Figure D

STEP 2: Mix the medicine

A. Look in the window.

You may see white medicine along the sides, bottom or top. This means the medicine is not mixed evenly.

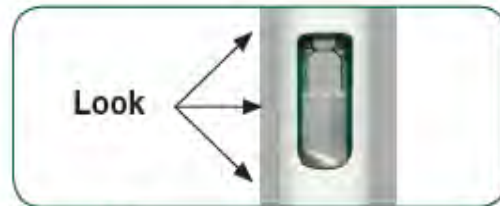

Figure E

- ### B. Shake the BYDUREON BCise autoinjector hard, in an up-and-down motion, until the medicine is mixed evenly and you do not see any white medicine along the sides, bottom or top. Shake for at least 15 seconds.



Figure F

C. Check the mix.

Hold the autoinjector up to the light and look through both sides and the bottom of the window. If not mixed well, repeat Step 2 and check again.

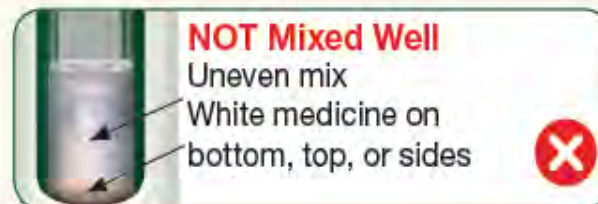

Figure G

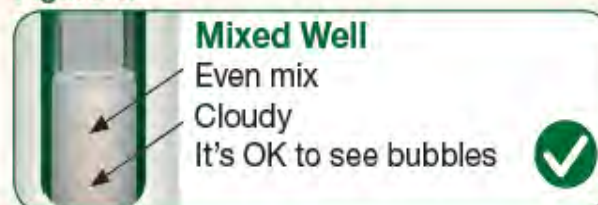

Figure H



Do not go to the next step unless your medicine is mixed well. To get a full dose, the medicine must be mixed well and look cloudy. If not mixed well, continue to shake hard.

STEP 3: Prepare the BYDUREON BCise Autoinjector

Important: After the medicine is fully mixed, you must complete the preparation steps **right away**, and inject to get the full dose. Do not save it to use later.

Only unlock the autoinjector when you are ready to inject

A. Unlock the autoinjector.

Hold the autoinjector up straight with the orange cap toward the ceiling. Turn the knob from the Lock to the Unlock position until you hear a click.



Figure I



Figure J

B. While still holding the autoinjector straight up, firmly unscrew the orange cap.

- You may need to turn the cap a few times before it loosens (if you hear clicking you are turning in the wrong direction).
- Continue holding the autoinjector upright to prevent the medicine from accidentally leaking.
- A green shield will pop up after the cap is removed. The green shield hides the needle.

It is normal to see a few drops of liquid inside the cap. **Do not** recap the autoinjector.

Throw away the cap.



Figure K



Figure L

Removed Cap



Figure M

Green shield pops up



Figure N

STEP 4: Inject the Dose

A. Inject and hold:

- DO NOT inject through clothing. Lift or remove clothing.
- Push the BYDUREON BCise autoinjector against your skin. You will hear a “click” when the injection begins.
- Keep holding the autoinjector against the skin for 15 seconds. This is to make sure you get the full dose.



Figure O

B. Make sure you received your full dose.

After you receive your injection, you will see an orange rod in the window. After you lift the autoinjector from your skin, the green shield will move back up to lock over the needle. See the Common Questions & Answers for what to do if you do not see the orange rod in the window after injection.



Figure P

STEP 4: Inject the Dose (continued)

C. Disposal.

Be careful when discarding the BYDUREON BCise autoinjector after use. Do not throw away your used autoinjector in your household trash or recycling bins.

- Put the autoinjector in a closeable, puncture-resistant sharps container (like a biohazard container).
- Do not recycle the filled sharps container.
- Ask your healthcare provider about options available in your area to dispose of the sharps container properly.



Figure Q

- The directions regarding autoinjector handling and disposal are not intended to replace local, healthcare provider or institutional policies.

Always keep your sharps container out of reach of children and animals.

See “Common Questions & Answers” for additional disposal information.

Common Questions and Answers

1. Where is the needle?

The needle is attached to the BYDUREON BCise autoinjector and covered by the orange cap. When you unscrew the orange cap, the green shield keeps the needle covered until you inject.

For more information, please see Figure N in Step 3B in the Instructions for Use.

2. How do I know if the medicine is fully mixed?

After shaking the autoinjector, look through both sides of the window. You should not see any white medicine along the bottom, top, or sides. If you see white medicine, it is unmixed. To mix, shake the autoinjector hard until the white medicine is no longer on the bottom, top, or sides. The medicine should look even throughout.

3. Why do I need to hold the BYDUREON BCise autoinjector upright while removing the orange cap?

Holding the autoinjector with the orange cap straight up helps prevent the medicine from leaking. It is normal to see a few drops of medicine inside the orange cap after you unscrew it.

4. Why should I inject my medicine right away after mixing it?

If you do not inject your medicine right away after mixing, the medicine may separate, and you will not get your full dose. You can re-mix your medicine if your autoinjector is in the locked position. However, after you unlock it, you must complete the preparation steps right away and inject to get the full dose. You cannot save it for later use.

Common Questions and Answers (continued)

5. How do I know I gave myself the full dose of medicine?

To be sure you get your full dose, press and hold the BYDUREON BCise autoinjector against your skin.

You will feel the needle go into your skin. Hold the needle against your skin for 15 seconds. This will allow enough time for all the medicine to go from the autoinjector to under your skin. After removing the needle, look for the orange rod in the window as a way to tell that the dose has been given. If the orange rod does not appear contact Medical Information at 1-800-668-6000.

6. Why should I store my autoinjectors flat in the refrigerator?

Autoinjectors stored vertically (with the needle up or down) are more difficult to mix. The medicine can still be fully mixed but it will take more shaking and more time.

7. What if I don't have a sharps disposal container?

Do not throw away (dispose of) the autoinjector in your household trash. Ask your healthcare provider about options available in your area to dispose of your autoinjector. Follow local, healthcare provider or institutional policies to dispose of your autoinjector.

Common Questions and Answers (continued)

8. What if the BYDUREON BCise device malfunctions and I cannot unlock it?

Review the Instructions for Use Step 3 to confirm the order of operations, then contact Medical Information at 1-800-668-6000 for help as needed. Do not try to unlock with excessive force or tools.

9. What if the BYDUREON BCise device malfunctions and I cannot remove the orange cap?

Review the Instructions for Use Step 3 to confirm the order of operations, also confirm that the knob is fully in the unlocked position, then contact Medical Information at 1-800-668-6000 for help as needed. Do not use tools or try to force the cap off.

10. For other questions about Bydureon BCise:

Questions or concerns: 1-800-668-6000

How to Store Bydureon BCise Autoinjector

- Store flat in the refrigerator between 2°C to 8°C.
- Each autoinjector can be kept at room temperature not to exceed 30°C for no more than a total of 4 weeks, if needed.
- Store in packaging provided to protect from light until you are ready to prepare and use your dose.
- Do not use past the expiration date. The expiration date is labeled EXP.
- Keep the autoinjector clean and away from spills.

HIGHLIGHTS OF PRESCRIBING INFORMATION

These highlights do not include all the information needed to use BYDUREON BCISE safely and effectively. See full prescribing information for BYDUREON BCISE.

BYDUREON BCISE® (exenatide extended-release) injectable suspension, for subcutaneous use.
Initial U.S. Approval: 2005

WARNING: RISK OF THYROID C-CELL TUMORS

See full prescribing information for complete boxed warning.

- Exenatide extended-release causes thyroid C-cell tumors at clinically relevant exposures in rats. It is unknown whether BYDUREON BCISE causes thyroid C-cell tumors, including medullary thyroid carcinoma (MTC) in humans, as the human relevance of exenatide extended-release-induced rodent thyroid C-cell tumors has not been determined. (5.1, 13.1)
- BYDUREON BCISE is contraindicated in patients with a personal or family history of MTC or in patients with Multiple Endocrine Neoplasia syndrome type 2 (MEN 2). Counsel patients regarding the potential risk of MTC and the symptoms of thyroid tumors. (4, 5.1)

RECENT MAJOR CHANGES

Indications and Usage, Limitations of Use (1)	7/2019
Contraindications (4)	2/2020
Warning and Precautions (5.8)	2/2020

INDICATIONS AND USAGE

BYDUREON BCISE is a glucagon-like peptide-1 (GLP-1) receptor agonist indicated as an adjunct to diet and exercise to improve glycemic control in adults with type 2 diabetes mellitus. (1, 14)

Limitations of Use:

- Not recommended as first-line therapy for patients inadequately controlled on diet and exercise. (1)
- Should not be used to treat type 1 diabetes or diabetic ketoacidosis. (1)
- Use with prandial insulin has not been studied. (1)
- BYDUREON BCISE is an extended-release formulation of exenatide. Do not coadminister with other exenatide containing products. (1)
- Has not been studied in patients with a history of pancreatitis. Consider other antidiabetic therapies in patients with a history of pancreatitis. (1, 5.2)

DOSAGE AND ADMINISTRATION

- Administer 2 mg by subcutaneous injection once every seven days (weekly), at any time of day and with or without meals. (2.1)
- Administer immediately after the dose is prepared. (2.3)

DOSAGE FORMS AND STRENGTHS

Extended-release injectable suspension: 2 mg of exenatide in a 0.85 mL single-dose autoinjector. (3)

CONTRAINDICATIONS

- Personal or family history of medullary thyroid carcinoma or in patients with Multiple Endocrine Neoplasia syndrome type 2. (4)

- Prior serious hypersensitivity reaction to exenatide or any of the product components. (4)
- History of drug-induced immune-mediated thrombocytopenia from exenatide products (4).

WARNINGS AND PRECAUTIONS

- **Acute Pancreatitis:** Including fatal and non-fatal hemorrhagic or necrotizing pancreatitis has been reported. Discontinue promptly if pancreatitis is suspected. Do not restart if pancreatitis is confirmed. Consider other antidiabetic therapies if patient has history of pancreatitis. (5.2)
- **Hypoglycemia:** When used in combination with an insulin secretagogue (e.g., a sulfonylurea) or insulin, consider lowering dose of the secretagogue or insulin to reduce risk of hypoglycemia. (5.3)
- **Acute Kidney Injury:** May induce nausea and vomiting with transient hypovolemia and may worsen renal function. Postmarketing increased serum creatinine, renal impairment, worsened chronic renal failure and acute renal failure, sometimes requiring hemodialysis or kidney transplantation has been reported. Not recommended for use in patients with eGFR below 45 mL/min/1.73 m². (5.4, 8.6, 12.3)
- **Gastrointestinal Disease:** Not recommended in patients with severe gastrointestinal disease (e.g., gastroparesis). (5.5)
- **Immunogenicity:** Patients may develop antibodies to exenatide. If there is worsening glycemic control or failure to achieve target glycemic control, consider alternative antidiabetic therapy. (5.6)
- **Hypersensitivity:** Serious hypersensitivity reactions (e.g., anaphylaxis and angioedema) have been reported. Discontinue BYDUREON BCISE and promptly seek medical advice. (5.7)
- **Drug-induced Immune-mediated Thrombocytopenia:** Serious bleeding which may be fatal has been reported. Discontinue BYDUREON BCISE promptly and avoid re-exposure to exenatide. (5.8)
- **Injection-site Reactions:** Serious injection-site reactions with or without subcutaneous nodules have been reported. (5.9)
- **Acute Gallbladder Disease:** If cholelithiasis or cholecystitis are suspected, gallbladder studies are indicated. (5.10)

ADVERSE REACTIONS

Most common (≥5%) in clinical trials: injection-site nodule, nausea. (6.1)

To report SUSPECTED ADVERSE REACTIONS, contact AstraZeneca at 1-800-236-9933 and www.bydureonbcise.com or FDA at 1-800-FDA-1088 or www.fda.gov/medwatch.

DRUG INTERACTIONS

- May impact absorption of orally administered medications. (7)
- Warfarin: Postmarketing reports with exenatide of increased international normalized ratio (INR) sometimes associated with bleeding. Monitor INR frequently until stable upon initiation of BYDUREON BCISE therapy. (7)

USE IN SPECIFIC POPULATIONS

- **Pregnancy:** Use during pregnancy only if the potential benefit justifies the risk to the fetus. (8.1)

See 17 for PATIENT COUNSELING INFORMATION and Medication Guide.

Revised: 2/2020

FULL PRESCRIBING INFORMATION: CONTENTS*

WARNING: RISK OF THYROID C-CELL TUMORS

1 INDICATIONS AND USAGE

2 DOSAGE AND ADMINISTRATION

- 2.1 Recommended Dosing
- 2.2 Missed Dose
- 2.3 Administration Instructions
- 2.4 Initiating BYDUREON BCISE Therapy

3 DOSAGE FORMS AND STRENGTHS

4 CONTRAINDICATIONS

5 WARNINGS AND PRECAUTIONS

- 5.1 Risk of Thyroid C-cell Tumors
- 5.2 Acute Pancreatitis
- 5.3 Hypoglycemia with Concomitant Use of Insulin Secretagogues or Insulin
- 5.4 Acute Kidney Injury
- 5.5 Gastrointestinal Disease

- 5.6 Immunogenicity
- 5.7 Hypersensitivity
- 5.8 Drug-Induced Thrombocytopenia
- 5.9 Injection-Site Reactions
- 5.10 Acute Gallbladder Disease

6 ADVERSE REACTIONS

- 6.1 Clinical Trial Experience
- 6.2 Immunogenicity
- 6.3 Postmarketing Experience

7 DRUG INTERACTIONS

8 USE IN SPECIFIC POPULATIONS

- 8.1 Pregnancy
- 8.2 Lactation
- 8.4 Pediatric Use
- 8.5 Geriatric Use
- 8.6 Renal Impairment

- 10 OVERDOSAGE**
- 11 DESCRIPTION**
- 12 CLINICAL PHARMACOLOGY**
 - 12.1 Mechanism of Action
 - 12.2 Pharmacodynamics
 - 12.3 Pharmacokinetics
- 13 NONCLINICAL TOXICOLOGY**
 - 13.1 Carcinogenesis, Mutagenesis, Impairment of Fertility
- 14 CLINICAL STUDIES**

- 14.1 Glycemic Control Trials in Adults with Type 2 Diabetes Mellitus
- 14.2 EXSCEL Cardiovascular Outcomes Trial in Patients with Type 2 Diabetes
- 16 HOW SUPPLIED/STORAGE AND HANDLING**
- 17 PATIENT COUNSELING INFORMATION**

*Sections or subsections omitted from the full prescribing information are not listed.

FULL PRESCRIBING INFORMATION

WARNING: RISK OF THYROID C-CELL TUMORS

- Exenatide extended-release causes an increased incidence in thyroid C-cell tumors at clinically relevant exposures in rats compared to controls. It is unknown whether BYDUREON BCISE causes thyroid C-cell tumors, including medullary thyroid carcinoma (MTC), in humans, as the human relevance of exenatide extended-release-induced rodent thyroid C-cell tumors has not been determined [see *Warnings and Precautions (5.1)* and *Nonclinical Toxicology (13.1)*].
- BYDUREON BCISE is contraindicated in patients with a personal or family history of MTC and in patients with Multiple Endocrine Neoplasia syndrome type 2 (MEN 2). Counsel patients regarding the potential risk for MTC with the use of BYDUREON BCISE and inform them of symptoms of thyroid tumors (e.g., mass in the neck, dysphagia, dyspnea, persistent hoarseness). Routine monitoring of serum calcitonin or using thyroid ultrasound is of uncertain value for detection of MTC in patients treated with BYDUREON BCISE [see *Contraindications (4)* and *Warnings and Precautions (5.1)*].

1 INDICATIONS AND USAGE

BYDUREON BCISE is indicated as an adjunct to diet and exercise to improve glycemic control in adults with type 2 diabetes mellitus [see *Clinical Studies (14)*].

Limitations of Use

- BYDUREON BCISE is not recommended as first-line therapy for patients who have inadequate glycemic control on diet and exercise because of the uncertain relevance of the rat thyroid C-cell tumor findings to humans [see *Warnings and Precautions (5.1)*].
- BYDUREON BCISE is not a substitute for insulin. BYDUREON BCISE is not indicated for use in patients with type 1 diabetes mellitus or for the treatment of diabetic ketoacidosis, as it would not be effective in these settings.
- The concurrent use of BYDUREON BCISE with prandial insulin has not been studied [see *Clinical Studies (14)*].
- BYDUREON BCISE is an extended-release formulation of exenatide. BYDUREON BCISE should not be used with other products containing the active ingredient exenatide.
- BYDUREON BCISE has not been studied in patients with a history of pancreatitis. Consider other antidiabetic therapies in patients with a history of pancreatitis [see *Warnings and Precautions (5.2)* and *Adverse Reactions (6.3)*].

2 DOSAGE AND ADMINISTRATION

2.1 Recommended Dosing

The recommended dose of BYDUREON BCISE is 2 mg subcutaneously once every 7 days (weekly). The dose can be administered at any time of day, with or without meals.

The day of weekly administration can be changed if necessary, as long as the last dose was administered 3 or more days before the new day of administration.

2.2 Missed Dose

If a dose is missed, administer the dose as soon as noticed, provided the next regularly scheduled dose is due at least 3 days later. Thereafter, patients can resume their usual dosing schedule of once every 7 days (weekly).

If a dose is missed and the next regularly scheduled dose is due 1 or 2 days later, do not administer the missed dose and instead resume BYDUREON BCISE with the next regularly scheduled dose.

2.3 Administration Instructions

- BYDUREON BCISE is intended for patient self-administration. Prior to initiation, train patients on proper mixing and injection technique to ensure the product is adequately mixed and a full dose is delivered [see *Instructions for Use*].
- Remove the autoinjector from the refrigerator 15 minutes prior to mixing the injection, in order to reach room temperature.
- Mix by shaking vigorously for at least 15 seconds. After mixing, BYDUREON BCISE should appear as an opaque, white to off-white suspension, evenly mixed with no residual medicine along the side, bottom or top of the inspection window.
- Inspect visually for particulate matter and discoloration prior to administration (BYDUREON BCISE contains microspheres which appear as white to off-white particles). Do not use if foreign particulate matter is present or if discoloration is observed. Refer patients to the accompanying Instructions for Use for disposal information [see *Instructions for Use*].
- Administer BYDUREON BCISE immediately after the autoinjector is prepared as a subcutaneous injection in the abdomen, thigh, or upper arm region. Advise patients to use a different injection site each week when injecting in the same region.
- Do not administer BYDUREON BCISE intravenously or intramuscularly.
- Refer patients to the accompanying Instructions for Use for complete administration instructions with illustrations [see *Instructions for Use*].

2.4 Initiating BYDUREON BCISE Therapy

Prior treatment with an immediate- or extended-release exenatide product is not required when initiating BYDUREON BCISE therapy. Discontinue an immediate- or extended-release exenatide product prior to initiation of BYDUREON BCISE.

Patients changing from immediate-release exenatide to BYDUREON BCISE may experience transient (approximately 2 to 4 weeks) elevations in blood glucose concentrations.

Patients changing from another extended-release exenatide product to BYDUREON BCISE may do so at the next regularly scheduled dose.

3 DOSAGE FORMS AND STRENGTHS

Extended-release injectable suspension: 2 mg of exenatide per 0.85 mL suspension, in a pre-filled single-dose autoinjector. Redispersion by mixing provides a white to off-white, opaque, suspension.

4 CONTRAINDICATIONS

BYDUREON BCISE is contraindicated in patients with:

- A personal or family history of medullary thyroid carcinoma (MTC) or in patients with Multiple Endocrine Neoplasia syndrome type 2 (MEN 2).
- A prior serious hypersensitivity reaction to exenatide or to any of the components of BYDUREON BCISE. Serious hypersensitivity reactions including anaphylactic reactions and angioedema have been reported with exenatide [see *Warnings and Precautions (5.7)*].
- A history of drug-induced immune-mediated thrombocytopenia from exenatide products. Serious bleeding, which may be fatal, from drug-induced immune-mediated thrombocytopenia has been reported with exenatide use [see *Warnings and Precautions (5.8)*].

5 WARNINGS AND PRECAUTIONS

5.1 Risk of Thyroid C-cell Tumors

In both genders of rats, exenatide extended-release caused a dose-related and treatment-duration–dependent increase in the incidence of thyroid C-cell tumors (adenomas and/or carcinomas) at clinically relevant exposures compared to controls [see *Nonclinical Toxicology (13.1)*]. A statistically significant increase in malignant thyroid C-cell carcinomas was observed in female rats receiving exenatide extended-release at 27-times clinical exposure compared to controls and higher incidences were noted in males above controls in all treated groups at ≥ 2 -times clinical exposure. The potential of exenatide extended-release to induce C-cell tumors in mice has not been evaluated. Other GLP-1 receptor agonists have also induced thyroid C-cell adenomas and carcinomas in male and female mice and rats at clinically relevant exposures. It is unknown whether BYDUREON BCISE will cause thyroid C-cell tumors, including medullary thyroid carcinoma (MTC), in humans as the human relevance of exenatide extended-release–induced rodent thyroid C-cell tumors has not been determined.

Cases of MTC in patients treated with liraglutide, another GLP-1 receptor agonist, have been reported in the postmarketing period; the data in these reports are insufficient to establish or exclude a causal relationship between MTC and GLP-1 receptor agonist use in humans.

BYDUREON BCISE is contraindicated in patients with a personal or family history of MTC or in patients with MEN 2. Counsel patients regarding the potential risk of MTC with the use of BYDUREON BCISE and inform them of symptoms of thyroid tumors (e.g., a mass in the neck, dysphagia, dyspnea, persistent hoarseness).

Routine monitoring of serum calcitonin or using thyroid ultrasound is of uncertain value for early detection of MTC in patients treated with BYDUREON BCISE. Such monitoring may increase the risk of unnecessary procedures, due to the low specificity of serum calcitonin testing for MTC and a high background incidence of thyroid disease. Significantly elevated serum calcitonin may indicate MTC and patients with MTC usually have values >50 ng/L. If serum calcitonin is measured and found to be elevated, the patient should be further evaluated. Patients with thyroid nodules noted on physical examination or neck imaging should also be further evaluated.

5.2 Acute Pancreatitis

Based on postmarketing data, exenatide has been associated with acute pancreatitis, including fatal and non-fatal hemorrhagic or necrotizing pancreatitis. After initiation of BYDUREON BCISE, observe patients carefully for signs and symptoms of pancreatitis (including persistent severe abdominal pain, sometimes radiating to the back, which may or may not be accompanied by vomiting). If pancreatitis is suspected, BYDUREON BCISE should promptly be discontinued and appropriate management should be initiated. If pancreatitis is confirmed, BYDUREON BCISE should not be restarted. Consider antidiabetic therapies other than BYDUREON BCISE in patients with a history of pancreatitis. In clinical trials of BYDUREON BCISE acute pancreatitis occurred in 0.4% of patients.

5.3 Hypoglycemia with Concomitant Use of Insulin Secretagogues or Insulin

The risk of hypoglycemia is increased when BYDUREON BCISE is used in combination with insulin secretagogues (e.g., sulfonylureas) or insulin. Patients may require a lower dose of the secretagogue or insulin to reduce the risk of hypoglycemia in this setting [*see Adverse Reactions (6.1)*].

5.4 Acute Kidney Injury

BYDUREON BCISE may induce nausea and vomiting with transient hypovolemia and may worsen renal function. There have been postmarketing reports of altered renal function with exenatide, including increased serum creatinine, renal impairment, worsened chronic renal failure and acute renal failure, sometimes requiring hemodialysis or kidney transplantation. Some of these events occurred in patients receiving one or more pharmacologic agents known to affect renal function or hydration status such as angiotensin converting enzyme inhibitors, nonsteroidal anti-inflammatory drugs, or diuretics. Some events occurred in patients who had been experiencing nausea, vomiting or diarrhea, with or without dehydration. Reversibility of altered renal function has been observed in many cases with supportive treatment and discontinuation of potentially causative agents, including BYDUREON (exenatide extended-release for injectable suspension). BYDUREON BCISE is not recommended for use in patients with an eGFR below 45 mL/min/1.73 m² [*see Use in Specific Populations (8.6)*].

5.5 Gastrointestinal Disease

Exenatide has not been studied in patients with severe gastrointestinal disease, including gastroparesis. Because exenatide is commonly associated with gastrointestinal adverse reactions, including nausea, vomiting, and diarrhea, the use of BYDUREON BCISE is not recommended in patients with severe gastrointestinal disease.

5.6 Immunogenicity

Patients may develop antibodies to exenatide following treatment with BYDUREON BCISE. Anti-exenatide antibodies were measured in BYDUREON BCISE-treated patients in two comparator-controlled 28-week studies of BYDUREON BCISE. Patients with higher titer antibodies may have an attenuated HbA_{1c} response. If there is worsening glycemic control or failure to achieve targeted glycemic control, consider alternative antidiabetic therapy [see *Adverse Reactions (6.2)*].

5.7 Hypersensitivity

There have been postmarketing reports of serious hypersensitivity reactions (e.g., anaphylaxis and angioedema) in patients treated with exenatide. If a hypersensitivity reaction occurs, the patient should discontinue BYDUREON BCISE and promptly seek medical advice [see *Contraindications (4)* and *Adverse Reactions (6.3)*]. Inform and closely monitor patients with a history of anaphylaxis or angioedema with another GLP-1 receptor agonist for allergic reactions, because it is unknown whether such patients will be predisposed to anaphylaxis with BYDUREON BCISE.

5.8 Drug-Induced Thrombocytopenia

Serious bleeding, which may be fatal, from drug-induced immune-mediated thrombocytopenia has been reported in the postmarketing setting with exenatide use. Drug-induced thrombocytopenia is an immune-mediated reaction with exenatide-dependent anti-platelet antibodies. In the presence of exenatide, these antibodies cause platelet destruction. If drug-induced thrombocytopenia is suspected, discontinue BYDUREON BCISE immediately and do not re-expose the patient to exenatide. Upon discontinuation, thrombocytopenia can persist due to the prolonged exenatide exposure from BYDUREON BCISE (about 10 weeks) [see *Adverse Reactions (6.3)*].

5.9 Injection-Site Reactions

There have been postmarketing reports of serious injection-site reactions (e.g., abscess, cellulitis, and necrosis), with or without subcutaneous nodules, with the use of BYDUREON [see *Adverse Reactions (6.3)*]. Isolated cases required surgical intervention.

5.10 Acute Gallbladder Disease

Acute events of gallbladder disease have been reported in GLP-1 receptor agonist trials. In the EXSCEL trial [see *Clinical Studies (14.2)*], 1.9% of BYDUREON-treated patients and 1.4% of placebo-treated patients reported an acute event of gallbladder disease, such as cholelithiasis or cholecystitis. If cholelithiasis is suspected, gallbladder studies and appropriate clinical follow-up are indicated.

6 ADVERSE REACTIONS

The following serious adverse reactions are described below or elsewhere in the prescribing information:

- Risk of Thyroid C-cell Tumors [see *Warnings and Precautions (5.1)*]
- Acute Pancreatitis [see *Warnings and Precautions (5.2)*]
- Hypoglycemia [see *Warnings and Precautions (5.3)*]
- Acute Kidney Injury [see *Warnings and Precautions (5.4)*]
- Gastrointestinal Disease [see *Warnings and Precautions (5.5)*]
- Immunogenicity [see *Warnings and Precautions (5.6)*]
- Hypersensitivity [see *Warnings and Precautions (5.7)*]
- Drug-Induced Thrombocytopenia [see *Warnings and Precautions (5.8)*]
- Injection-Site Reactions [see *Warnings and Precautions (5.9)*]
- Acute Gallbladder Disease [see *Warnings and Precautions (5.10)*]

6.1 Clinical Trial Experience

Because clinical trials are conducted under widely varying conditions, adverse reaction rates observed in the clinical trials of a drug cannot be directly compared to rates in the clinical trials of another drug and may not reflect the rates observed in practice.

The data in this section are derived from pooled data from the controlled period of the 2 comparator-controlled trials as well as data from the extension phase of one of these trials [see *Clinical Studies (14)*]. There were 410 patients exposed to BYDUREON BCISE 2 mg for 28 weeks during the controlled phases, and an additional 116 patients exposed to BYDUREON BCISE 2 mg during an uncontrolled extension for an additional 24 weeks. Overall, there were 526 patients exposed to BYDUREON BCISE 2 mg with a mean duration of exposure of 35 weeks in the controlled and extension phases of the two trials. Across the treatment arms in the controlled periods, the mean age of patients was 55 years, 2% were 75 years or older and 59% were male. The population in these studies was 78% White, 15% Black or African American, 5% Asian; 1% American Indian or Alaska Native; <1 % were Native Hawaiian or Pacific Islander; and <1% were other races. This population included 42% of Hispanic or Latino ethnicity. At baseline, the population had diabetes for an average of 8.3 years and had a mean HbA_{1c} of 8.5%. Baseline estimated renal function was normal or mildly impaired (eGFR \geq 60 mL/min/1.73 m²) in 93% of the pooled study populations.

Common Adverse Reactions

Table 1 summarizes the adverse reactions with an incidence \geq 5% occurring in BYDUREON BCISE-treated patients in the pooled data from the controlled and extension phases, including 10 weeks of follow-up, of the two comparator-controlled 28-week clinical trials. Adverse reactions were identified based on known adverse reactions associated with BYDUREON.

Table 1: Adverse Reactions Reported in $\geq 5\%$ of BYDUREON BCISE-Treated Patients from Pooled Clinical Trial Data in Patients with Type 2 Diabetes Mellitus

	BYDUREON BCISE 2 mg N = 526 %
Injection site nodule	10.5
Nausea	8.2

Note: Percentages are based on the number of patients who were randomized and received at least one dose of BYDUREON BCISE.

Nausea was a common adverse reaction associated with initiation of treatment with BYDUREON BCISE and usually decreased over time with continued use. The incidence of nausea and/or vomiting was 2% in the first week of therapy compared to 1% in the 4th week of therapy.

Less Common Adverse Reactions

Adverse reactions that occurred in $>2\%$ and $<5\%$ of patients receiving BYDUREON BCISE during the controlled and extension phases, including 10 weeks of follow-up, of the two comparator-controlled 28-week clinical trials include: headache (4.4%), diarrhea (4.0%), vomiting (3.4%), injection site pruritus (3.2%), dizziness (2.5%), injection site erythema (2.3%), constipation (2.1%).

Adverse Reactions Leading to Discontinuation of Therapy

The incidence of discontinuation of therapy due to adverse reactions was 3.9% for BYDUREON BCISE-treated patients in the two comparator-controlled 28-week trials. The most common classes of adverse reactions leading to discontinuation of therapy for BYDUREON BCISE-treated patients were Gastrointestinal Disorders 2.0% and General Disorders and Administration Site Conditions 1.2%. For BYDUREON BCISE-treated patients, the most frequent adverse reactions leading to discontinuation of therapy within each of these respective classes were diarrhea (0.7%), nausea (0.7%), vomiting (0.5%) and injection-site nodule (0.5%).

Other Adverse Reactions

Hypoglycemia

Table 2 summarizes the incidence of glucose level <54 mg/dL regardless of hypoglycemia clinical symptoms and the incidence of severe hypoglycemia in the two comparator-controlled 28-week trials of BYDUREON BCISE.

Table 2: Incidence (% of Subjects) of Hypoglycemia (glucose <54 mg/dL) and Severe Hypoglycemia in Clinical Trials in Patients with Type 2 Diabetes Mellitus

Incidence of Hypoglycemia (glucose <54 mg/dL)	
Mono- or Combination Therapy with One or Two OADs Trial (28 weeks)	
With Concomitant Sulfonylurea Use	
BYDUREON BCISE 2 mg (N=88)	25.0%
Without Concomitant Sulfonylurea Use	
BYDUREON BCISE 2 mg (N=141)	2.1%
Add-On to Metformin Trial (28 weeks)	
All treated subjects	
BYDUREON BCISE 2 mg (N=181)	0.0%
Incidence of Severe Hypoglycemia	
Mono- or Combination Therapy with One or Two OADs Trial (28 weeks)	
With Concomitant Sulfonylurea Use	
BYDUREON BCISE 2 mg (N=88)	2.3%
Without Concomitant Sulfonylurea Use	
BYDUREON BCISE 2 mg (N=141)	0.7%
Add-On to Metformin Trial (28 weeks)	
All treated subjects	
BYDUREON BCISE 2 mg (N=181)	0.0%

Note: N and percentages are based on the number of patients who were randomized and received at least one dose of BYDUREON BCISE.

Severe hypoglycemia was defined as clinical symptoms that were considered to result from hypoglycemia in which the patient required the assistance of another person and associated with recovery after oral carbohydrates, intravenous glucose or glucagon administration if no plasma glucose was available.

Injection-Site Adverse Reactions

In the two comparator-controlled 28-week trials, injection site reactions (including injection site nodule, injection site pruritus, injection site bruising) were observed in 23.9% of patients treated with BYDUREON BCISE. The formation of subcutaneous nodules is consistent with the properties of the microspheres used in BYDUREON BCISE.

Increase in Heart Rate

In clinical trials of BYDUREON BCISE the mean increase from baseline in heart rate was 2.4 beats per minute.

6.2 Immunogenicity

As with all therapeutic proteins, there is potential for immunogenicity. The detection of antibody formation is highly dependent on the sensitivity and specificity of the assay. Additionally, the observed incidence of antibody (including neutralizing antibody) positivity in an assay may be influenced by several factors including assay methodology, sample handling, timing of sample collection, concomitant medications, and underlying disease. For these reasons, comparison of the incidence of antibodies to exenatide in the studies described below with the incidence of antibodies in other studies or to other products may be misleading.

Anti-exenatide antibodies were measured at prespecified intervals in 393 BYDUREON BCISE-treated patients in the two comparator-controlled studies. In these trials 42.2% of these patients developed low titer antibodies to exenatide and approximately 31.8% of patients developed high titer antibodies at any time during the studies. The percentage of patients with positive antibody titers, in particular high titers, peaked at approximately Weeks 8-16 of dosing and then diminished over time.

Change in HbA_{1c} from baseline in patients with low titer antibodies at the last visit was generally comparable to that observed in antibody-negative patients at the last visit. However, patients with higher titer antibodies may have an attenuated HbA_{1c} response.

Amongst BYDUREON BCISE-treated patients evaluable for antibodies (N=393), the incidence of potentially immunogenic injection site reactions (most commonly injection site nodule) during the 28-week studies was approximately 19.6%. These reactions were less commonly observed in antibody-negative patients (15.7%) and patients with low titer antibodies (16.3%) compared with those with high titer antibodies (27.2%).

A total of 246 patients with antibodies to exenatide in the BYETTA and BYDUREON clinical trials were tested for the presence of cross-reactive antibodies to GLP-1 and/or glucagon. No treatment-emergent cross-reactive antibodies were observed across the range of titers.

6.3 Postmarketing Experience

The following adverse reactions have been identified during post-approval use of BYDUREON BCISE or other formulations of exenatide. Because these reactions are reported voluntarily from a population of uncertain size, it is not always possible to reliably estimate their frequency or establish a causal relationship to drug exposure.

Allergy/Hypersensitivity: injection-site reactions, generalized pruritus and/or urticaria, macular or papular rash, angioedema; anaphylactic reaction.

Blood and Lymphatic Systems: drug-induced thrombocytopenia [see [Warnings and Precautions \(5.8\)](#)]

Drug Interactions: increased international normalized ratio (INR) sometimes associated with bleeding, with concomitant warfarin [see [Drug Interactions \(7\)](#)].

Gastrointestinal: nausea, vomiting, and/or diarrhea resulting in dehydration; abdominal distension, abdominal pain, eructation, constipation, flatulence, acute pancreatitis, hemorrhagic and necrotizing pancreatitis sometimes resulting in death [see [Indications and Usage \(1\)](#)].

Neurologic: dysgeusia; somnolence

Renal and Urinary Disorders: altered renal function, including increased serum creatinine, renal impairment, worsened chronic renal failure or acute renal failure (sometimes requiring hemodialysis), kidney transplant and kidney transplant dysfunction.

Skin and Subcutaneous Tissue Disorders: alopecia

7 DRUG INTERACTIONS

Table 3: Clinically Relevant Interactions Affecting Drugs Co-Administered with BYDUREON BCISE and Other Exenatide-Containing Products

Orally Administered Drugs (e.g., acetaminophen)	
Clinical Impact	Exenatide slows gastric emptying. Therefore, BYDUREON BCISE has the potential to reduce the rate of absorption of orally administered drugs. <i>[see Clinical Pharmacology (12.3)].</i>
Intervention	Use caution when administering oral medications with BYDUREON BCISE where a slower rate of oral absorption may be clinically meaningful.
Warfarin	
Clinical Impact	BYDUREON BCISE has not been studied with warfarin. However, in a drug interaction study, BYETTA did not have a significant effect on INR <i>[see Clinical Pharmacology (12.3)]</i> . There have been postmarketing reports for exenatide of increased INR with concomitant use of warfarin, sometimes associated with bleeding <i>[see Adverse Reactions (6.3)]</i> .
Intervention	In patients taking warfarin, the INR should be monitored more frequently after initiating BYDUREON BCISE. Once a stable INR has been documented, the INR can be monitored at the intervals usually recommended for patients on warfarin.
Concomitant Use of Insulin Secretagogues or Insulin	
Clinical Impact	Exenatide promotes insulin release from pancreatic beta-cells in the presence of elevated glucose concentrations. The risk of hypoglycemia is increased when exenatide is used in combination with insulin secretagogues (e.g., sulfonylureas) or insulin <i>[see Adverse Reactions (6.1)]</i> .
Intervention	Patients may require a lower dose of the secretagogue or insulin to reduce the risk of hypoglycemia in this setting.

8 USE IN SPECIFIC POPULATIONS

8.1 Pregnancy

Risk Summary

Limited data with exenatide, the active ingredient in BYDUREON BCISE, in pregnant women are not sufficient to determine a drug-associated risk for major birth defects or miscarriage. There are risks to the mother and fetus associated with poorly controlled diabetes in pregnancy (*see Clinical Considerations*). Based on animal reproduction studies, there may be risks to the fetus from exposure to BYDUREON BCISE during pregnancy. BYDUREON BCISE should be used during pregnancy only if the potential benefit justifies the potential risk to the fetus.

Animal reproduction studies identified increased adverse fetal and neonatal outcomes from exposure to exenatide extended-release during pregnancy or from exposure to exenatide during pregnancy and lactation, in association with maternal effects. In rats, exenatide extended-release, administered during the

period of organogenesis, reduced fetal growth and produced skeletal ossification deficits at doses that approximate clinical exposures at the maximum recommended human dose (MRHD) of 2 mg/week. In mice, exenatide administered during gestation and lactation, caused increased neonatal deaths at doses that approximate clinical exposures at the MRHD (*see Data*). Based on animal data, advise pregnant women of the potential risk to a fetus.

The estimated background risk of major birth defects is 6-10% in women with pre-gestational diabetes with an HbA_{1c} >7 and has been reported to be as high as 20-25% in women with HbA_{1c} >10. The estimated background risk of miscarriage for the indicated population is unknown. In the U.S. general population, the estimated background risk of major birth defects and miscarriage in clinically recognized pregnancies is 2-4% and 15-20%, respectively.

Clinical Considerations

Disease-associated maternal and/or embryofetal risk

Poorly controlled diabetes in pregnancy increases the maternal risk for diabetic ketoacidosis, preeclampsia, spontaneous abortions, preterm delivery and delivery complications. Poorly controlled diabetes increases the fetal risk for major birth defects, stillbirth, and macrosomia related morbidity.

Data

Animal Data

Pregnant rats given subcutaneous doses of 0.3, 1, or 3 mg/kg exenatide extended-release every 3 days during organogenesis had systemic exposures 3-, 8-, and 19-times human exposure, respectively, at the MRHD of 2 mg/week BYDUREON BCISE based on plasma exenatide exposure (AUC) comparison. Reduced fetal growth at all doses and skeletal ossification deficits at 1 and 3 mg/kg occurred at doses that decreased maternal food intake and body weight gain.

In studies evaluating reproduction and development in pregnant mice and rabbits, maternal animals were administered exenatide, the active ingredient in BYDUREON BCISE, by subcutaneous injection twice a day. Differences in embryo-fetal developmental toxicity from subcutaneously injected exenatide extended-release and exenatide were not evaluated in mice, rats, or rabbits.

In pregnant mice given 6, 68, 460, or 760 mcg/kg/day exenatide during fetal organogenesis, skeletal variations associated with slowed fetal growth, including changes in number of rib pairs or vertebral ossifications sites, and wavy ribs were observed at 760 mcg/kg/day, a dose that produced maternal toxicity and yielded systemic exposure 200 times the human exposure resulting from the MRHD of BYDUREON BCISE based on AUC comparison.

In pregnant rabbits given 0.2, 2, 22, 156, or 260 mcg/kg/day exenatide during fetal organogenesis, irregular fetal skeletal ossifications were observed at 2 mcg/kg/day, a dose yielding systemic exposure up to 6 times the human exposure from the MRHD of BYDUREON BCISE based on AUC comparison.

In maternal mice given 6, 68, or 760 mcg/kg/day exenatide from gestation day 6 through lactation day 20 (weaning), an increased number of neonatal deaths at 6 mcg/kg/day were observed on postpartum days 2

to 4 in dams given 6 mcg/kg/day, a dose yielding a systemic exposure equivalent to the human exposure from the MRHD of BYDUREON BCISE based on AUC comparison.

8.2 Lactation

Risk Summary

There is no information regarding the presence of exenatide, in human milk, the effects of exenatide on the breastfed infant, or the effects of exenatide on milk production. Exenatide, the active ingredient in BYDUREON BCISE was present in the milk of lactating mice. However, due to species-specific differences in lactation physiology, the clinical relevance of these data is not clear (*see Data*). The developmental and health benefits of breastfeeding should be considered along with the mother's clinical need for exenatide and any potential adverse effects on the breastfed child from exenatide or from the underlying maternal condition.

Data

In lactating mice subcutaneously injected twice a day with exenatide, the active ingredient in BYDUREON BCISE, the concentration of exenatide in milk was up to 2.5% of the concentration in maternal plasma.

8.4 Pediatric Use

Safety and effectiveness of BYDUREON BCISE have not been established in pediatric patients. BYDUREON BCISE is not recommended for use in pediatric patients.

8.5 Geriatric Use

In two comparator-controlled 28-week trials, BYDUREON BCISE was studied in 74 patients (18.0%) who were at least 65 years old and 10 patients who were at least 75 years old. No meaningful differences in safety and efficacy were observed between these patients and the overall population, but the small sample size for patients ≥ 75 years old limits conclusions. In a large cardiovascular outcomes trial, BYDUREON was studied in 2959 patients (40.3%) who were at least 65 years old and of those, 605 patients (8.2%) were at least 75 years old. Use caution when initiating BYDUREON BCISE in elderly patients because they are more likely to have decreased renal function.

8.6 Renal Impairment

Pharmacokinetic studies of renally impaired patients receiving BYDUREON BCISE indicate that there is an increase in exposure in moderate and mild renally impaired patients as compared to patients with normal renal function. BYDUREON BCISE may induce nausea and vomiting with transient hypovolemia and may worsen renal function.

Monitor patients with mild renal impairment for adverse reactions that may lead to hypovolemia. BYDUREON BCISE is not recommended for use in patients with eGFR below 45 mL/min/1.73 m² or end-stage renal disease. If used in patients with renal transplantation, closely monitor for adverse reactions that may lead to hypovolemia [*see Warnings and Precautions (5.4) and Clinical Pharmacology (12.3)*].

10 OVERDOSAGE

Effects of overdoses with BYETTA, another formulation of exenatide, included severe nausea, severe vomiting, and rapidly declining blood glucose concentrations, including severe hypoglycemia requiring parenteral glucose administration. In the event of overdose, appropriate supportive treatment should be initiated according to the patient's clinical signs and symptoms.

11 DESCRIPTION

BYDUREON BCISE (exenatide extended-release) injectable suspension is a GLP-1 receptor agonist supplied as a sterile suspension of exenatide extended-release microspheres in an oil-based vehicle of medium chain triglycerides (MCT), in a single-dose autoinjector. Redispersion by mixing provides a white to off-white-opaque suspension to be administered by subcutaneous injection. Each autoinjector contains sufficient suspension to deliver 2 mg of exenatide extended-release in a volume of 0.85 mL.

Exenatide is a 39-amino acid synthetic peptide amide with an empirical formula of $C_{184}H_{282}N_{50}O_{60}S$ and a molecular weight of 4186.6 Daltons. The amino acid sequence for exenatide is shown below.

H-His-Gly-Glu-Gly-Thr-Phe-Thr-Ser-Asp-Leu-Ser-Lys-Gln-Met-Glu-Glu-Glu-Ala-Val-Arg-Leu-Phe-Ile-Glu-Trp-Leu-Lys-Asn-Gly-Gly-Pro-Ser-Ser-Gly-Ala-Pro-Pro-Pro-Ser-NH₂

Exenatide is incorporated in an extended-release microsphere formulation containing the 50:50 poly(D,L-lactide-co-glycolide) polymer (37.2 mg per dose) along with sucrose (0.8 mg per dose), suspended in the vehicle, MCT (774.4 mg per dose).

12 CLINICAL PHARMACOLOGY

12.1 Mechanism of Action

Incretins, such as glucagon-like peptide-1 (GLP-1), enhance glucose-dependent insulin secretion and exhibit other antihyperglycemic actions following their release into the circulation from the gut. Exenatide is a GLP-1 receptor agonist that enhances glucose-dependent insulin secretion by the pancreatic beta-cell, suppresses inappropriately elevated glucagon secretion, and slows gastric emptying.

The amino acid sequence of exenatide partially overlaps that of human GLP-1. Exenatide is a GLP-1 receptor agonist that has been shown to bind and activate the human GLP-1 receptor *in vitro*. This leads to an increase in both glucose-dependent synthesis of insulin and *in vivo* secretion of insulin from pancreatic beta-cells, by mechanisms involving cyclic AMP and/or other intracellular signaling pathways. Exenatide promotes insulin release from pancreatic beta-cells in the presence of elevated glucose concentrations.

12.2 Pharmacodynamics

Exenatide improves glycemic control through the actions described below.

Glucose-Dependent Insulin Secretion

The effect of exenatide infusion on glucose-dependent insulin secretion rates (ISR) was investigated in 11 healthy subjects. In these healthy subjects, on average, the ISR response was glucose-dependent (Figure 1). Exenatide did not impair the normal glucagon response to hypoglycemia.

Figure 1: Mean (SE) Insulin Secretion Rates During Infusion of Exenatide or Placebo by Treatment, Time, and Glycemic Condition in Healthy Subjects

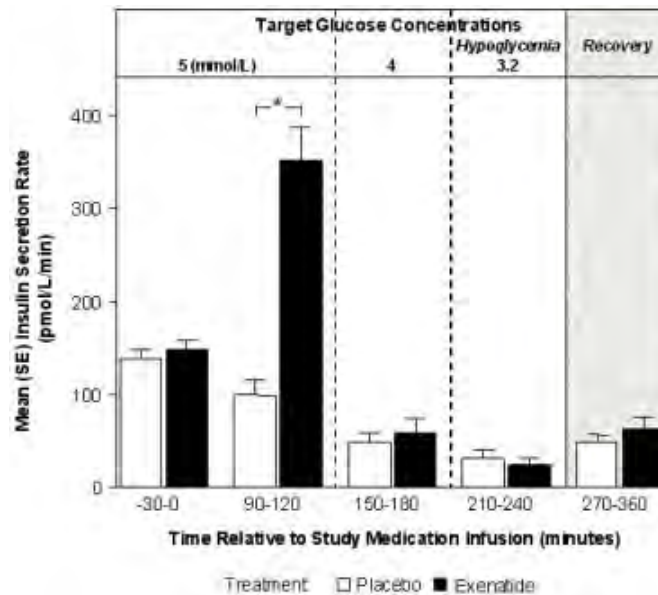

SE = standard error.

Notes: 5 mmol = 90 mg/dL, 4 mmol/L = 72 mg/dL, 3.2 mmol/L = 58 mg/dL; Study medication infusion was started at time = 0 minutes.

Statistical assessments were for the last 30 minutes of each glycemic step, during which the target glucose concentrations were maintained.

*p <0.05, exenatide treatment relative to placebo.

Glucagon Secretion

In patients with type 2 diabetes, exenatide moderates glucagon secretion and lowers serum glucagon concentrations during periods of hyperglycemia.

Gastric Emptying

Exenatide slows gastric emptying, thereby reducing the rate at which postprandial glucose appears in the circulation.

Fasting and Postprandial Glucose

In a 12-week clinical pharmacology study of exenatide microspheres suspended in MCT-oil in adults with type 2 diabetes mellitus, reductions in fasting plasma glucose were evident after 2 weeks of treatment, and after 12 weeks resulted in a reduction of fasting plasma glucose concentrations of -40.4 mg/dL, when compared to placebo.

In a clinical study of BYDUREON BCISE, 2-hour postprandial glucose levels were measured at Week 16, during a mixed meal tolerance test, in a subset of patients with type 2 diabetes mellitus. The mean change from baseline was -78 mg/dL.

Cardiac Electrophysiology

The effect of exenatide at therapeutic (253 pg/mL) and suprathreshold (627 pg/mL) concentrations, following an intravenous infusion on QTc interval was evaluated in a randomized, placebo- and active-controlled (moxifloxacin 400 mg) three-period crossover thorough QT study in 74 healthy subjects. The upper bound of the one-sided 95% confidence interval for the largest placebo adjusted, baseline-corrected QTc based on population correction method (QTcP) was below 10 ms. Therefore, exenatide was not associated with prolongation of the QTc interval at therapeutic and suprathreshold concentrations.

12.3 Pharmacokinetics

Absorption

Following a single subcutaneous dose of exenatide microspheres suspended in MCT-oil, there is an initial period of release of surface-bound exenatide followed by a gradual release of exenatide from the microspheres, which results in a peak of plasma exenatide concentration at around Week 6 to Week 7 representing the hydration and erosion of the microspheres.

Following initiation of once every 7 days (weekly) administration of 2 mg BYDUREON BCISE, a gradual increase in the plasma exenatide concentration is observed up to approximately Week 10. From Week 10 mean plasma exenatide concentrations of approximately 208 pg/mL were maintained over once every 7 days (weekly) dosing intervals indicating that steady state was achieved.

Distribution

The mean apparent volume of distribution of exenatide following subcutaneous administration of a single-dose of BYETTA is 28.3 L and is expected to remain unchanged for BYDUREON BCISE.

Metabolism

Elimination

Nonclinical studies have shown that exenatide is predominantly eliminated by glomerular filtration with subsequent proteolytic degradation. The mean apparent clearance of exenatide in humans is 9.1 L/hour and is independent of the dose. Approximately 10 weeks after discontinuation of BYDUREON BCISE therapy, plasma exenatide concentrations generally fall below the minimal quantifiable concentration of 20 pg/mL.

Drug Interaction Studies

The following drug interactions have been studied using BYDUREON. The potential for drug-drug interaction with BYDUREON BCISE is expected to be similar to that of BYDUREON.

Acetaminophen

When 1000 mg acetaminophen tablets were administered, either with or without a meal, following 14 weeks of BYDUREON therapy (2 mg weekly), no significant changes in acetaminophen AUC were observed compared to the control period. Acetaminophen C_{\max} decreased by 16% (fasting) and 5% (fed) and T_{\max} was increased from approximately 1 hour in the control period to 1.4 hours (fasting) and 1.3 hours (fed).

The following drug interactions have been studied using BYETTA. The potential for drug-drug interaction with BYDUREON BCISE is expected to be similar to that of BYETTA.

Digoxin

Administration of repeated doses of BYETTA 30 minutes before oral digoxin (0.25 mg once daily) decreased the C_{\max} of digoxin by 17% and delayed the T_{\max} of digoxin by approximately 2.5 hours; however, the overall steady-state pharmacokinetic exposure (e.g., AUC) of digoxin was not changed.

Lovastatin

Administration of BYETTA (10 mcg twice daily) 30 minutes before a single oral dose of lovastatin (40 mg) decreased the AUC and C_{\max} of lovastatin by approximately 40% and 28%, respectively, and delayed the T_{\max} by about 4 hours compared with lovastatin administered alone. In the 30-week controlled clinical trials of BYETTA, the use of BYETTA in patients already receiving HMG CoA reductase inhibitors was not associated with consistent changes in lipid profiles compared to baseline.

Lisinopril

In patients with mild to moderate hypertension stabilized on lisinopril (5-20 mg/day), BYETTA (10 mcg twice daily) did not alter steady-state C_{\max} or AUC of lisinopril. Lisinopril steady-state T_{\max} was delayed by 2 hours. There were no changes in 24-hour mean systolic and diastolic blood pressure.

Oral Contraceptives

The effect of BYETTA (10 mcg twice daily) on single and on multiple doses of a combination oral contraceptive (30 mcg ethinyl estradiol plus 150 mcg levonorgestrel) was studied in healthy female subjects. Repeated daily doses of the oral contraceptive (OC) given 30 minutes after BYETTA administration decreased the C_{\max} of ethinyl estradiol and levonorgestrel by 45% and 27%, respectively, and delayed the T_{\max} of ethinyl estradiol and levonorgestrel by 3.0 hours and 3.5 hours, respectively, as compared to the oral contraceptive administered alone. Administration of repeated daily doses of the OC one hour prior to BYETTA administration decreased the mean C_{\max} of ethinyl estradiol by 15%, but the mean C_{\max} of levonorgestrel was not significantly changed as compared to when the OC was given alone. BYETTA did not alter the mean trough concentrations of levonorgestrel after repeated daily dosing of the oral contraceptive for both regimens. However, the mean trough concentration of ethinyl estradiol was increased by 20% when the OC was administered 30 minutes after BYETTA administration injection as compared to when the OC was given alone. The effect of BYETTA on OC pharmacokinetics is confounded by the possible food effect on OC in this study [*see Drug Interactions (7)*].

Warfarin

Administration of warfarin (25 mg) 35 minutes after repeated doses of BYETTA (5 mcg twice daily on days 1-2 and 10 mcg twice daily on days 3-9) in healthy volunteers delayed warfarin T_{max} by approximately 2 hours. No clinically relevant effects on C_{max} or AUC of *S*- and *R*-enantiomers of warfarin were observed. BYETTA did not significantly alter the pharmacodynamic properties (e.g., international normalized ratio) of warfarin [see [Drug Interactions \(7\)](#)].

Specific Populations

Patients with Renal Impairment

BYDUREON BCISE has not been studied in patients with severe renal impairment (CrCL <30 mL/min, eGFR <30 mL/min/1.73m²) or end-stage renal disease receiving dialysis. Pharmacokinetic analysis of patients receiving 2 mg BYDUREON BCISE indicated that there was an 28% and 69% higher systemic exposure to exenatide in patients with mild (N=96) or moderate (N=24) renal impairment, respectively, as compared to patients with normal renal function (N=70) [see [Warnings and Precautions \(5.4\)](#) and [Use in Specific Populations \(8.6\)](#)]. In a study of BYETTA in subjects with end-stage renal disease receiving dialysis, mean exenatide exposure increased by 3.4-fold compared to that of subjects with normal renal function [see [Warnings and Precautions \(5.4\)](#) and [Use in Specific Populations \(8.6\)](#)].

Patients with Hepatic Impairment

BYDUREON BCISE has not been studied in patients with acute or chronic hepatic impairment.

Age, Male and Female Patients, Race, and Body Weight

Age, gender, race and body weight did not alter the pharmacokinetics of BYDUREON BCISE in population pharmacokinetic analyses.

Pediatric Patients

BYDUREON BCISE has not been studied in pediatric patients [see [Use in Specific Populations \(8.4\)](#)].

13 NONCLINICAL TOXICOLOGY

13.1 Carcinogenesis, Mutagenesis, Impairment of Fertility

Thyroid C-cell tumors have been observed in rats and mice with GLP-1 receptor agonists.

A 2-year carcinogenicity study was conducted with exenatide extended-release, the active component of BYDUREON BCISE, in male and female rats at doses of 0.3, 1.0, and 3.0 mg/kg (2-, 10-, and 27-times human systemic exposure at the maximum recommended human dose (MRHD) of 2 mg/week. BYDUREON BCISE based on plasma exenatide AUC, respectively) administered by subcutaneous injection every other week. In this study there was an increased incidence of C-cell adenomas and C-cell carcinomas at all doses. An increase in benign fibromas was seen in the skin subcutis at injection sites of males given 3 mg/kg. No treatment-related injection-site fibrosarcomas were observed at any dose. The human relevance of these findings is currently unknown.

Carcinogenicity of exenatide extended-release has not been evaluated in mice.

Exenatide, the active ingredient in BYDUREON BCISE, was not mutagenic or clastogenic, with or without metabolic activation, in the Ames bacterial mutagenicity assay or chromosomal aberration assay in Chinese hamster ovary cells. Exenatide was negative in the *in vivo* mouse micronucleus assay.

In mouse fertility studies with exenatide, the active ingredient in BYDUREON BCISE, at twice-daily subcutaneous doses of 6, 68, or 760 mcg/kg/day, males were treated for 4 weeks prior to and throughout mating, and females were treated 2 weeks prior to mating and throughout mating until gestation day 7. No adverse effect on fertility was observed at 760 mcg/kg/day, a systemic exposure 163 times the human exposure resulting from the recommended dose of 2 mg/week, based on AUC.

14 CLINICAL STUDIES

14.1 Glycemic Control Trials in Adults with Type 2 Diabetes Mellitus

BYDUREON BCISE has been studied as monotherapy and in combination with metformin, a sulfonylurea, a thiazolidinedione, a combination of metformin and a sulfonylurea, or a combination of metformin and a thiazolidinedione.

BYDUREON BCISE versus BYETTA, Both as Monotherapy or as Add-on to Metformin, a Sulfonylurea, a Thiazolidinedione, or Combination of Oral Agents

A 28-week, randomized, open-label comparator-controlled trial was conducted to compare the safety and efficacy of BYDUREON BCISE to BYETTA in patients with type 2 diabetes and inadequate glycemic control with diet and exercise alone or with oral antidiabetic therapy, including metformin, a sulfonylurea, a thiazolidinedione, or a combination of any two of these therapies (NCT01652716).

A total of 375 patients were studied: 278 (74%) were Caucasian, 61 (16%) Black or African American, 25 (7%) Asian, 5 (1%) listed as other, 5 (1%) American Indian or Alaska Native, and 1 (<1%) Native Hawaiian or Other Pacific Islander. Patients were treated with diet and exercise alone (13%), a single oral antidiabetic agent (49%), or combination therapy of oral antidiabetic agents (38%). The mean baseline HbA_{1c} was 8.5%. Patients were randomly assigned to receive BYDUREON BCISE 2 mg once every 7 days (weekly) (n=229) or BYETTA (10 mcg twice daily) (n=146), in addition to existing oral antidiabetic agents. Patients assigned to BYETTA initiated treatment with 5 mcg twice daily then increased the dose to 10 mcg twice daily after 4 weeks.

The primary endpoint was change in HbA_{1c} from baseline to Week 28. The results for the primary endpoint at Week 28 are summarized in Table 4. Treatment with BYDUREON BCISE 2 mg once weekly (QW) resulted in a statistically significantly greater reduction in HbA_{1c} compared to BYETTA 10 mcg twice daily. The mean reduction in HbA_{1c} was non-inferior compared with BYETTA 10 mcg twice daily at the pre-specified non-inferiority margin +0.4% in this study. BYDUREON BCISE 2 mg QW was statistically superior to BYETTA 10 mcg twice daily (ANCOVA p-value=0.0032).

Table 4: Results of 28-Week Trial of BYDUREON BCISE versus BYETTA, Both as Monotherapy or as Add-On to Metformin, a Sulfonylurea, a Thiazolidinedione, or Combination of Oral Agents in Patients with Type 2 Diabetes Mellitus

	BYDUREON BCISE 2 mg QW	BYETTA 10 mcg twice daily*
Intent-to-Treat Population (N)	229	146
HbA_{1c} (%)		
Mean Baseline	8.5	8.5
Mean Change at Week 28	-1.39	-1.03
Difference from BYETTA* [95% CI]	-0.36 [†] (-0.66, -0.14)	

N = number of patients in each treatment group, CI = unadjusted confidence interval, QW = once weekly.

* Least squares means were obtained using an Analysis of Covariance (ANCOVA) model with treatment, baseline HbA_{1c}, baseline HbA_{1c} stratum (<9% or ≥9%), diabetes management method at screening (diet/exercise alone, SU use, or non-SU use), and renal function (normal, mild, or moderate renal impairment) in the population included subjects discontinued treatment before 28 weeks regardless of initiation of rescue medicine.

† p-value <0.01

The proportions of subjects achieving HbA_{1c} <7.0% at Week 28 were 40% in BYDUREON BCISE group compared to 38% in BYETTA group. Subjects with missing values at Week 28 counted as non-responders. The mean changes from baseline to Week 28 for fasting plasma glucose were -36 mg/dL and -27 mg/dL for BYDUREON BCISE and BYETTA, respectively, and for body weight were -1.4 kg and -1.9 kg for BYDUREON BCISE and BYETTA, respectively.

BYDUREON BCISE versus Sitagliptin and Placebo, All as Add-on to Metformin Therapy

A 28-week open-label (oral medication blinded), comparator- and placebo-controlled trial was conducted to compare the safety and efficacy of BYDUREON BCISE to sitagliptin and placebo in patients with type 2 diabetes whose glycemic control was inadequate with metformin therapy (NCT01652729).

A total of 364 patients were studied, 296 (81%) were Caucasian, 49 (14%) Black or African American, 14 (4%) Asian and 3 (<1%) American Indian or Alaska Native, 1 (<1%) Native Hawaiian or Other Pacific Islander, and 1 (<1%) was classified otherwise. The mean baseline HbA_{1c} was 8.5%. Patients were randomly assigned to receive BYDUREON BCISE 2 mg once every 7 days (weekly) (n=181), sitagliptin 100 mg/day (n=122) or placebo (n=61), in addition to their existing metformin therapy.

The primary endpoint was change in HbA_{1c} from baseline to Week 28. Results for the primary endpoint at 28 weeks are summarized in Table 5. In this study, treatment with BYDUREON BCISE 2 mg once weekly resulted in a statistically significant mean reduction in HbA_{1c} compared to placebo. BYDUREON BCISE 2 mg was statistically superior to placebo (ANCOVA p-value=0.02).

Table 5: Results of 28-Week Trial of BYDUREON BCISE versus Sitagliptin and Placebo, All as Add-On to Metformin Therapy

	BYDUREON BCISE 2 mg QW	Sitagliptin 100 mg/day	Placebo once daily
Intent-to-Treat Population (N)	181	122	61
HbA_{1c} (%)			
Mean Baseline	8.4	8.5	8.5
Mean Change at Week 28	-1.07	-0.79	-0.59
Difference from sitagliptin ^{*,†} [95% CI]	-0.28 (-0.62, 0.02)		
Difference from placebo [*] [95% CI]	-0.49 (-0.91, -0.07) [‡]		

N = number of patients in each treatment group, CI = unadjusted confidence interval, QW = once weekly.

* Least squares means were obtained using an Analysis of Covariance (ANCOVA) model with treatment, baseline HbA_{1c} and baseline HbA_{1c} stratum (<9% or ≥ 9%) in the population included subjects discontinued treatment before 28 weeks regardless of initiation of rescue medicine.

† Sitagliptin 100 mg/day did not show the superiority to placebo in this study.

‡ p-value <0.05

The proportions of subjects who achieved an HbA_{1c} <7.0% at Week 28 were 41%, 31%, and 26% in BYDUREON BCISE, Sitagliptin and Placebo groups, respectively. Subjects with missing values at Week 28 counted as non-responders. The mean changes from baseline to Week 28 for fasting plasma glucose were -24 mg/dL, -19 mg/dL and -1 mg/dL for BYDUREON BCISE, Sitagliptin and Placebo, respectively, and for body weight were -1.4 kg, -1.2 kg, and 0.4 kg for BYDUREON BCISE, Sitagliptin and Placebo, respectively.

BYDUREON, another formulation of exenatide extended-release, has been studied as monotherapy and in combination with metformin, sulfonylurea, thiazolidinedione, SGLT2 inhibitor and basal insulin.

BYDUREON Monotherapy versus Metformin, Sitagliptin, and Pioglitazone

A 26-week, randomized, comparator-controlled trial was conducted to compare the safety and efficacy of BYDUREON to metformin, sitagliptin, and pioglitazone in patients with type 2 diabetes whose glycemic control was inadequate with diet and exercise (NCT00676338).

A total of 820 patients were studied: 552 (67%) were Caucasian, 102 (12%) were East Asian, 71 (9%) were West Asian, 65 (8%) were Hispanic, 25 (3.0%) were Black, 4 (0.5%) were Native American, and 1 was classified otherwise. The mean baseline HbA_{1c} was 8.5%. Patients were randomly assigned to receive BYDUREON 2 mg once every seven days (weekly), titrated metformin from 1000 to 2500 mg/day, sitagliptin 100 mg/day or titrated pioglitazone from 30 to 45 mg/day, all dosed according to approved labeling.

The primary endpoint was change in HbA_{1c} from baseline to Week 26 (or the last value at time of early discontinuation). Treatment with BYDUREON 2 mg once weekly (QW) resulted in mean HbA_{1c} reduction that was statistically significantly greater compared to sitagliptin 100 mg/day. The mean reduction in HbA_{1c} was non-inferior compared with metformin 1000-2500 mg/day (mean dose 2077 mg/day at study endpoint). Non-inferiority of BYDUREON 2 mg QW to pioglitazone 30-45 mg/day

(mean dose 40 mg/day at study endpoint) in reducing HbA_{1c} after 26 weeks of treatment was not demonstrated (the mean change from baseline in HbA_{1c} after 26 weeks was -1.6% with BYDUREON and -1.7% with pioglitazone). The non-inferiority margin was set at +0.3% in this study. The results for the primary endpoint at 26 weeks are summarized in Table 6.

Table 6: Results of 26-Week Trial of BYDUREON Monotherapy versus Metformin, Sitagliptin, and Pioglitazone in Patients with Type 2 Diabetes Mellitus

	BYDUREON 2 mg QW	Metformin 1000-2500 (mean dose 2077) mg/day	Sitagliptin 100 mg/day	Pioglitazone 30-45 (mean dose 40) mg/day
Intent-to-Treat Population (N)	248	246	163	163
HbA_{1c} (%)				
Mean Baseline	8.4	8.6	8.4	8.5
Mean Change at Week 26*	-1.6	-1.5	-1.2	-1.7
Difference from metformin* [Bonferroni-adjusted 98.3% CI]	-0.05 [-0.26, 0.17]			
Difference from sitagliptin* [Bonferroni-adjusted 98.3% CI]	-0.39 [†] [-0.63, -0.16]			
Difference from pioglitazone* [Bonferroni-adjusted 98.3% CI]	0.16 [-0.08, 0.41]			

N = number of patients in each treatment group.

Note: mean change is least squares mean change.

Note: The primary efficacy analysis was adjusted for multiple comparisons and a two-sided 98.3% confidence interval was utilized to assess difference between treatments.

Note: HbA_{1c} change data at 26 weeks were available from 86%, 87%, 85%, and 82% of the randomized subjects in the BYDUREON, metformin, sitagliptin, and pioglitazone groups, respectively.

QW = once weekly.

* Least squares means were obtained using a mixed model repeated measure analysis with treatment, pooled country, visit, baseline HbA_{1c} value, and treatment by visit interaction as fixed effects, and subject as a random effect.

[†] p<0.001, treatment vs comparator.

The proportion of patients with a Week 26 value achieving HbA_{1c} of less than 7% at Week 26 were 56%, 52%, 40%, and 55% for BYDUREON, metformin, sitagliptin, and pioglitazone, respectively. Patients who did achieve and HbA_{1c} goal <7% and discontinued before Week 26 were not included as responders. The mean changes from baseline to Week 26 for fasting serum glucose were -41 mg/dL, -36 mg/dL, -20 mg/dL and -46 mg/dL, and for body weight were -2.0 kg, -2.0 kg, -0.8 kg and +1.5 kg for BYDUREON, metformin, sitagliptin, and pioglitazone, respectively.

BYDUREON versus Sitagliptin and Pioglitazone, All as Add-on to Metformin Therapy

A 26-week double-blind comparator-controlled trial was conducted to compare the safety and efficacy of BYDUREON to sitagliptin and pioglitazone in patients with type 2 diabetes whose glycemic control was inadequate with metformin therapy (NCT00637273).

A total of 491 patients were studied 168 (34.2%) were Caucasian, 143 (29.1%) were Hispanic, 119 (24.2%) were Asian, 52 (10.6%) were Black, 3 (0.6%) were Native American, and 6 (1.2%) were classified otherwise. The mean baseline HbA_{1c} was 8.5%. Patients were randomly assigned to receive

BYDUREON 2 mg once every 7 days (weekly), sitagliptin 100 mg/day or pioglitazone 45 mg/day, in addition to their existing metformin therapy.

The primary endpoint was change in HbA_{1c} from baseline to Week 26 (or the last value at time of early discontinuation). In this study, treatment with BYDUREON 2 mg QW resulted in a statistically significant mean HbA_{1c} reduction compared to sitagliptin 100 mg/day. There was a numerically greater reduction in HbA_{1c} with BYDUREON compared to pioglitazone, but there was not sufficient evidence to conclude superiority of BYDUREON 2 mg QW to pioglitazone 45 mg/day in reducing HbA_{1c} after 26 Weeks of treatment. Results for the primary endpoint at 26 Weeks are summarized in Table 7.

Table 7: Results of 26-Week Trial of BYDUREON versus Sitagliptin and Pioglitazone, All as Add-On to Metformin Therapy in Patients with Type 2 Diabetes Mellitus

	BYDUREON 2 mg QW	Sitagliptin 100 mg/day	Pioglitazone 45 mg/day
Intent-to-Treat Population (N)	160	166	165
HbA_{1c} (%)			
Mean Baseline	8.6	8.5	8.5
Mean Change at Week 26*	-1.5	-0.9	-1.2
Difference from sitagliptin* [95% CI]	-0.63 [-0.89, -0.37]		
Difference from pioglitazone* [95% CI]	-0.32 [-0.57, -0.06]		

N = number of patients in each treatment group.

Note: mean change is least squares mean change.

QW = once weekly.

* Least squares means were obtained using an ANCOVA model with treatment, baseline HbA_{1c} stratum, and country as fixed effects. Missing Week 26 data (28%, 18%, and 24% for the BYDUREON, sitagliptin, and pioglitazone groups, respectively) were imputed by the LOCF technique.

The proportion of patients with a week 26 value achieving HbA_{1c} of less than 7% at Week 26 were 46%, 30%, and 39% for BYDUREON, sitagliptin, and pioglitazone, respectively. Patients who did achieve an HbA_{1c} goal <7% and discontinued before Week 26 were not included as responders. The mean changes from baseline to Week 26 for fasting serum glucose were -32 mg/dL, -16 mg/dL and -27 mg/dL, and for body weight were -2.3 kg, -0.8 kg and +2.8 kg for BYDUREON, sitagliptin, and pioglitazone, respectively.

BYDUREON versus Insulin Glargine, Both as Add-on to Metformin or Metformin + Sulfonylurea Therapy

A 26-week open-label comparator-controlled trial was conducted to compare the safety and efficacy of BYDUREON to titrated insulin glargine in patients with type 2 diabetes whose glycemic control was inadequate with metformin or metformin plus sulfonylurea therapy (NCT00641056).

A total of 456 patients were studied: 379 (83.1%) were Caucasian, 47 (10.3%) were Hispanic, 25 (5.5%) were East Asian, 3 (0.7%) were Black, and 2 (0.4%) were West Asian. Background therapy was either metformin (70%) or metformin plus sulfonylurea (30%). The mean baseline HbA_{1c} was 8.3%. Patients were randomly assigned to receive BYDUREON 2 mg once every 7 days (weekly) or insulin glargine once daily in addition to their existing oral antidiabetic therapy. Insulin glargine was dosed to a target

fasting glucose concentration of 72 to 100 mg/dL. The mean dose of insulin glargine was 10 units/day at baseline and 31 units/day at endpoint. At Week 26, 21% of insulin glargine treated patients were at fasting glucose goal.

The primary endpoint was change in HbA_{1c} from baseline to Week 26 (or the last value at time of early discontinuation). Treatment with BYDUREON once weekly resulted in a mean reduction in HbA_{1c} from baseline at 26 weeks of -1.5%. The mean reduction in HbA_{1c} seen in insulin glargine arm at 26 weeks was -1.3%. The difference in observed effect size between BYDUREON and glargine in this trial excluded the pre-specified non-inferiority margin of +0.3%.

The proportion of patients with a Week 26 value achieving HbA_{1c} of less than 7% at Week 26 were 57% and 48% for BYDUREON and insulin glargine, respectively. Patients who did achieve an HbA_{1c} goal <7% and discontinued before Week 26 were not included as responders. The mean changes from baseline to Week 26 for fasting serum glucose in this study were -38 mg/dL and -50 mg/dL, and for body weight were -2.6 kg and +1.4 kg for BYDUREON and insulin glargine, respectively.

BYDUREON versus Liraglutide, Both as Add-on to Metformin, a Sulfonylurea, Metformin + Sulfonylurea, or Metformin + Pioglitazone Therapy

A 26-week open-label comparator-controlled trial was conducted to compare the safety and efficacy of BYDUREON to liraglutide in patients with type 2 diabetes whose glycemic control was inadequate with metformin, a sulfonylurea, metformin plus sulfonylurea, or metformin plus pioglitazone therapy (NCT01029886).

A total of 911 patients were studied: 753 (82.7%) were Caucasian, 111 (12.2%) were Asian, 32 (3.5%) were American Indian or Alaska Native, 8 (0.9%) were Black, 6 (0.7%) were multiple races, and 1 (0.1%) was Pacific Islander. Background therapy was either a single oral antidiabetic agent (35%) or a combination of oral antidiabetic agents (65%). The mean baseline HbA_{1c} was 8.4%. Patients were randomly assigned to receive BYDUREON 2 mg once every 7 days (weekly) or liraglutide uptitrated from 0.6 mg/day to 1.2 mg/day, then 1.8 mg/day in addition to their existing oral antidiabetic therapy. Each titration was to be completed after at least one week, but could be delayed if the patient had severe nausea or vomiting as established by the investigator. Patients not tolerating the 1.8 mg/day dose of liraglutide by Week 4 were discontinued from the study.

The primary endpoint was change in HbA_{1c} from baseline to Week 26 (or the last value at time of early discontinuation). Treatment with BYDUREON once weekly resulted in a mean reduction in HbA_{1c} from baseline at 26 weeks of -1.3%. The mean reduction in HbA_{1c} seen in the liraglutide arm at 26 weeks was -1.5%. The HbA_{1c} reduction with BYDUREON did not meet predefined non-inferiority criteria compared to liraglutide 1.8 mg/day. The non-inferiority margin was set at +0.25% in this study. Results for the primary endpoint at 26 weeks are summarized in Table 8.

Table 8: Results of 26-Week Trial of BYDUREON versus Liraglutide, Both as Add-On to Metformin, a Sulfonylurea, Metformin + Sulfonylurea, or Metformin + Pioglitazone Therapy in Patients with Type 2 Diabetes Mellitus

	BYDUREON 2 mg QW	Liraglutide 1.8 mg/day
Intent-to-Treat Population (N)	461	450
HbA_{1c} (%)		
Mean Baseline	8.5	8.4
Mean Change at Week 26*	-1.3	-1.5
Difference from liraglutide* [95% CI]	0.2 [0.08, 0.33]	

N = number of patients in each treatment group.

Note: mean change is least squares mean change.

Note: HbA_{1c} change data at 26 weeks were available from 85% and 86% of the randomized subjects in the BYDUREON and liraglutide groups, respectively.

QW = once weekly.

* Least squares means were obtained using a mixed model repeated measure analysis with treatment, country, OAD stratum, baseline HbA_{1c} stratum, visit, baseline HbA_{1c} and treatment by visit interaction as fixed effects, and subject as a random effect.

The proportion of patients with a Week 26 value achieving HbA_{1c} of less than 7% at Week 26 were 48% and 56% for BYDUREON and liraglutide, respectively. Patients who did achieve an HbA_{1c} goal <7% and discontinued before Week 26 were not included as responders. The mean changes from baseline to week 26 for fasting serum glucose were -32 mg/dL and -38 mg/dL, and for body weight were -2.7 kg and -3.6 kg for BYDUREON and liraglutide, respectively.

BYDUREON in Combination with Dapagliflozin versus BYDUREON Alone and Dapagliflozin Alone, All as Add-On to Metformin

A 28-week double-blind comparator controlled trial was conducted to compare the efficacy of BYDUREON and dapagliflozin (an SGLT2 inhibitor) to BYDUREON alone and dapagliflozin alone in patients with type 2 diabetes with inadequate glycemic control with metformin therapy (NCT02229396).

A total of 694 patients were studied; 580 (83.6%) were Caucasian, 96 (13.8%) were Black, 5 (0.7%) were Asian, 2 (0.3%) were American Indian or Alaska Native, and 11 (1.6%) were classified otherwise. The mean baseline HbA_{1c} was 9.3%. All patients entered a 1-week placebo lead-in period. Patients with HbA_{1c} ≥8.0% and ≤12% and on metformin at a dose of at least 1,500 mg per day were randomly assigned to receive either BYDUREON 2 mg once every 7 days (weekly) plus dapagliflozin 10 mg once daily, BYDUREON 2 mg once weekly, or dapagliflozin 10 mg once daily.

The primary endpoint was change in HbA_{1c} from baseline to Week 28. At Week 28, BYDUREON in combination with dapagliflozin provided statistically significantly greater reductions in HbA_{1c} (-1.77%) compared to BYDUREON alone (-1.42%, p=0.012) and dapagliflozin alone (-1.32%, p=0.001). BYDUREON in combination with dapagliflozin provided statistically significantly greater reductions in FPG (-57.35 mg/dL) compared to BYDUREON alone (-40.53, p <0.001) and dapagliflozin alone (-44.72 mg/dL, p=0.006).

BYDUREON versus Placebo, Both as Add-On to Basal Insulin or Basal Insulin + Metformin Therapy

A 28-week, double-blind, placebo-controlled trial was conducted to compare the safety and efficacy of BYDUREON to placebo when added to basal insulin glargine, with or without metformin, in patients with type 2 diabetes with inadequate glycemic control (NCT02229383).

A total of 460 patients were studied: 400 (87.0%) were White, 47 (10.2%) were Black or African American, 6 (1.3%) were Asian, 1 (0.2%) was American Indian or Alaska Native, 1 (0.2%) was Pacific Islander, and 5 (1.1%) were classified otherwise. Patients on sulfonylurea therapy discontinued sulfonylurea. Patients on metformin continued on the same dose of metformin. All patients initially entered an 8-week insulin dose-titration phase. Insulin glargine was to be titrated every 3 days with an aim of achieving a target fasting plasma glucose concentration of 72 to 99 mg/dL. Following the titration period, patients with HbA_{1c} \geq 7.0% and \leq 10.5% were then randomly assigned to receive either BYDUREON 2 mg once every 7 days (weekly) or placebo once every 7 days (weekly).

The primary endpoint was the change in HbA_{1c} from baseline to Week 28. Compared to placebo, treatment with BYDUREON resulted in a statistically significant reduction in mean HbA_{1c} from baseline to Week 28 (Table 9).

Table 9: Results of 28-Week Trial of BYDUREON versus Placebo, Both as Add-On to Insulin Glargine or Insulin Glargine + Metformin

	BYDUREON 2 mg QW	Placebo QW
Intent-to-Treat Population (N)	231	229
Mean HbA_{1c} (%)		
Mean Baseline	8.53	8.53
Mean Change at Week 28*	-0.88 (0.070)	-0.24 (0.069)
Difference from Placebo [95% CI]	-0.64 [†] [-0.83, -0.45]	
Percentage Achieving HbA_{1c} <7.0% at Week 28 (%)[‡]	32.5 [†]	7.0

N = number of patients in each treatment group, CI = confidence interval, QW = once weekly.

Note: mean change is least squares mean change.

*Adjusted LS means and treatment group difference(s) in the change from baseline values at Week 28 using a multiple imputation method that models a “wash-out” for patients having missing data who discontinued treatment. ANCOVA was used with treatment, region, baseline HbA_{1c} stratum (<9.0% or \geq 9.0%), and baseline SU-use stratum (yes vs. no) as fixed factors, and baseline value as a covariate.

[†] p-value <0.001 (adjusted for multiplicity).

[‡]Categories are derived from continuous measurements. All patients with missing endpoint data are imputed as non-responders. Treatment comparison is based on Cochran-Mantel-Haenszel (CMH) test stratified by baseline HbA_{1c} (<9.0% or \geq 9.0%), and baseline SU-use stratum (yes vs. no). P-values are from the general association statistics.

Analyses include measurements post rescue therapy and post premature discontinuation of study medication.

The mean change in fasting plasma glucose from baseline to Week 28 was -12.50 mg/dL for BYDUREON and -2.26 mg/dL for placebo. The mean change from baseline to Week 28 in body weight was -0.92 kg for BYDUREON and +0.38 kg for placebo.

14.2 EXSCEL Cardiovascular Outcomes Trial in Patients with Type 2 Diabetes

EXSCEL was a multinational, placebo-controlled, double-blind, randomized, parallel group pragmatic study that evaluated cardiovascular (CV) outcomes during treatment with BYDUREON (exenatide extended-release for injectable suspension) in patients with type 2 diabetes and any level of CV risk when added to the current usual care (NCT01144338).

A total of 14,752 patients were randomized 1:1 to either BYDUREON 2 mg once weekly or placebo and followed as in routine clinical practice for a median of 38.7 months with a median treatment duration of 27.8 months. Ninety six percent of the patients in both treatment groups completed the study in accordance with the protocol, and the vital status was known at the end of the study for 98.9% and 98.8% of the patients in the BYDUREON and placebo group, respectively. The mean age at study entry was 62 years (21 to 92 years with 8.5% of the patients ≥ 75 years). Approximately 62.0% of the patients were male, 75.8% were Caucasian, 9.8% were Asian, 6.0% were Black, and 20.5% were Hispanic or Latino. The mean BMI was 32.7 kg/m² and the mean duration of diabetes was 13.1 years. Approximately 49.3% had mild renal impairment (estimated glomerular filtration rate [eGFR] ≥ 60 to ≤ 89 mL/min/1.73 m²) and 21.6% had moderate renal impairment (eGFR ≥ 30 to ≤ 59 mL/min/1.73 m²).

The mean HbA_{1c} was 8.1%. At baseline, 1.5% of patients were not treated with either oral antidiabetic medications or insulin, 42.3% were treated with one oral antidiabetic medication and 42.4% were treated with two or more oral antidiabetic medications. Usage of oral antidiabetic medications included metformin (76.6%), sulfonylurea (36.6%), DPP-4 inhibitors (14.9%), thiazolidinediones (3.9%), and SGLT-2 inhibitors (0.9%). Overall insulin usage was 46.3% (13.8% with insulin alone and 32.6% with insulin and one or more oral antidiabetic medications).

Overall, at baseline, 26.9% of patients did not have established cardiovascular (CV) disease, while 73.1% had established CV disease. The concomitant use of CV medications (e.g., ACE inhibitors, angiotensin receptor blockers, diuretics, beta blockers, calcium channel blockers, antithrombotic and anticoagulants, and lipid-lowering agents) was similar in the BYDUREON and placebo groups. At baseline, the mean systolic blood pressure was 135.5 mmHg, the mean diastolic blood pressure was 78.1 mmHg, the mean LDL was 95.0 mg/dL, and the mean HDL was 44.0 mg/dL.

The primary endpoint in EXSCEL was the time to first confirmed Major Adverse Cardiac Event (MACE) from randomization. MACE was defined as occurrence of either a cardiovascular (CV)-related death, or a nonfatal myocardial infarction (MI) or a nonfatal stroke. All-cause mortality, CV-related death, and fatal or nonfatal MI or stroke, hospitalization for acute coronary syndrome, and hospitalization for heart failure were also assessed as secondary endpoints.

A Cox proportional hazards model was used to test for non-inferiority against the pre-specified risk margin of 1.3 for the hazard ratio of MACE and superiority on MACE if non-inferiority was demonstrated. Type-1 error was controlled across multiples tests using a hierarchical testing strategy.

BYDUREON did not increase the risk of MACE in patients with type 2 diabetes mellitus (HR: 0.91; 95% CI: 0.832, 1.004; P<0.001 for non-inferiority; P=0.06 for superiority). See results in Table 10 and Figure 2. The incidence of MACE in patients with and without established CV disease was 13.4% in the BYDUREON group versus 14.6% in the placebo group and 6.0% (BYDUREON) versus 5.9% (placebo),

respectively. Five hundred and seven (507) patients (6.9%) died in the BYDUREON group versus 584 (7.9%) in the placebo group.

Table 10: Analysis of Primary Composite Endpoint MACE and Its Components in Patients with Type 2 Diabetes

	BYDUREON N=7356	Placebo N=7396	HR* (95% CI)
MACE Composite of CV death, nonfatal MI or nonfatal stroke (time to first confirmed event)	839 (11.4%)	905 (12.2%)	0.91 (0.832, 1.004)
Cardiovascular Death	340 (4.6%)	383 (5.2%)	0.88 (0.76, 1.02)
Nonfatal Myocardial Infarction	466 (6.3%)	480 (6.5%)	0.96 (0.85, 1.09)
Nonfatal Stroke	169 (2.3%)	193 (2.6%)	0.86 (0.70, 1.06)

N=number of patients in each treatment group, HR=hazard ratio, CI=confidence interval, CV=cardiovascular, MI=myocardial infarction.

* HR (active/placebo) and CI are based on Cox proportional hazards regression model, stratified by established CV disease, with treatment group only as explanatory variable.

Figure 2: Time to First Adjudicated MACE in Patients with Type 2 Diabetes

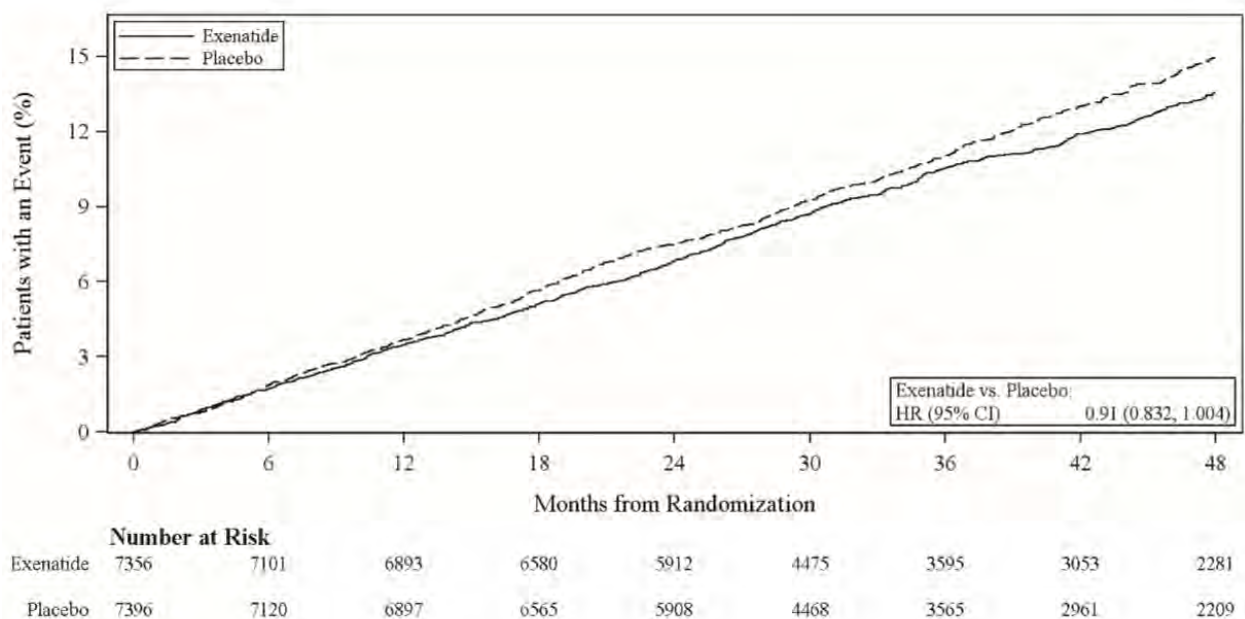

HR=hazard ratio, CI=confidence interval.

16 HOW SUPPLIED/STORAGE AND HANDLING

How Supplied

- BYDUREON BCISE contains 2 mg of exenatide in 0.85 mL vehicle, in a pre-filled, single-dose autoinjector. Redispersion by mixing provides a white to off-white, opaque, extended-release

injectable suspension, available in cartons that contain four single-dose autoinjectors (NDC 0310-6540-04).

Storage and Handling

- BYDUREON BCISE must be stored FLAT.
- Store the autoinjector in the original package. Protect from light.
- BYDUREON BCISE should be stored in the refrigerator at 36°F to 46°F (2°C to 8°C), up to the expiration date or until preparing for use. BYDUREON BCISE should not be used past the expiration date. The expiration date can be found on the carton, or on the autoinjector label.
- BYDUREON BCISE can be kept at room temperature not to exceed 86°F (30°C) for no more than a total of 4 weeks, if needed.
- Discard BYDUREON BCISE after use in a puncture-resistant container.

17 PATIENT COUNSELING INFORMATION

Advise the patient to read the FDA-approved patient labeling (Medication Guide and Instructions for Use).

Risk of Thyroid C-cell Tumors

Inform patients that exenatide extended-release causes benign and malignant thyroid C-cell tumors in rats and that the human relevance of this finding has not been determined. Counsel patients to report symptoms of thyroid tumors (e.g., a lump in the neck, hoarseness, dysphagia, or dyspnea) to their physician [see *Boxed Warning and Warnings and Precautions (5.1)*].

Risk of Pancreatitis

Inform patients treated with BYDUREON BCISE of the potential risk for pancreatitis. Explain that persistent severe abdominal pain that may radiate to the back, and which may or may not be accompanied by vomiting, is the hallmark symptom of acute pancreatitis. Instruct patients to discontinue BYDUREON BCISE promptly and contact their healthcare provider if persistent severe abdominal pain occurs [see *Warnings and Precautions (5.2)*].

Risk of Hypoglycemia

Inform patients that the risk of hypoglycemia is increased when BYDUREON BCISE is used in combination with an agent that induces hypoglycemia, such as a sulfonylurea or insulin [see *Warnings and Precautions (5.3)*]. Explain the symptoms, treatment, and conditions that predispose to the development of hypoglycemia. Review and reinforce instructions for hypoglycemia management when initiating BYDUREON BCISE therapy, particularly when concomitantly administered with a sulfonylurea or insulin [see *Warnings and Precautions (5.3)*].

Risk of Acute Kidney Injury

Inform patients treated with BYDUREON BCISE of the potential risk for worsening kidney function and explain the associated signs and symptoms of renal impairment, as well as the possibility of dialysis as a medical intervention if renal failure occurs [see *Warnings and Precautions (5.4)*].

Risk of Hypersensitivity Reactions

Inform patients that serious hypersensitivity reactions have been reported during postmarketing use of exenatide. Inform patients that if symptoms of hypersensitivity reaction occur, stop taking BYDUREON BCISE and seek medical advice promptly [see *Warnings and Precautions (5.7)*].

Risk of Drug-Induced Thrombocytopenia

Inform patients that drug-induced immune mediated thrombocytopenia has been reported during use of exenatide. Inform patients that if symptoms of thrombocytopenia occur, e.g. bleeding, stop taking BYDUREON BCISE and seek medical advice promptly [see *Warnings and Precautions (5.8)*].

Risk of Injection-Site Reactions

Inform patients that there have been postmarketing reports of serious injection-site reactions with or without subcutaneous nodules, with the use of BYDUREON. Isolated cases of injection-site reactions required surgical intervention. Advise patients to seek medical advice if symptomatic nodules occur, or for any signs or symptoms of abscess, cellulitis, or necrosis [see *Warnings and Precautions (5.9)*].

Acute Gallbladder Disease

Inform patients of the potential risk for cholelithiasis or cholecystitis. Instruct patients to contact their physician if cholelithiasis or cholecystitis is suspected for appropriate clinical follow-up [see *Warnings and Precautions (5.10)*].

Instructions

Train patients on how to use BYDUREON BCISE properly prior to self-administration. Instruct patients on proper mixing and injection technique to ensure the product is adequately mixed and a full dose is delivered. Refer patients to the accompanying Instructions for Use for complete administration instructions with illustrations.

Inform patients formerly on BYETTA who start BYDUREON BCISE may experience transient elevations in blood glucose concentrations, which generally improve within the first 4 weeks after initiation of therapy [see *Dosage and Administration (2.4)*].

Treatment with BYDUREON BCISE may also result in nausea, particularly upon initiation of therapy [see *Adverse Reactions (6)*].

Inform patients about the importance of proper storage of BYDUREON BCISE [see *How Supplied/Storage and Handling (16)*].

Instruct the patient to review the BYDUREON BCISE Medication Guide and the Instructions for Use each time the prescription is refilled.

Manufactured for:
AstraZeneca Pharmaceuticals LP
Wilmington, DE 19850

By:
Amylin Ohio LLC
West Chester, OH 45071
and
Vetter Pharma-Fertigung GmbH & Co. KG
88214 Ravensburg
Germany

BYDUREON, BCISE and BYETTA are trademarks of the AstraZeneca group of companies.

MEDICATION GUIDE
BYDUREON BCISE® (by-DUR-ee-on B-cise)
(exenatide extended-release)
injectable suspension, for subcutaneous use

What is the most important information I should know about BYDUREON BCISE?

BYDUREON BCISE may cause serious side effects, including:

- **Possible thyroid tumors, including cancer.** Tell your healthcare provider if you get a lump or swelling in your neck, hoarseness, trouble swallowing, or shortness of breath. These may be symptoms of thyroid cancer. In studies with rats, BYDUREON and medicines that work like BYDUREON caused thyroid tumors, including thyroid cancer. It is not known if BYDUREON BCISE will cause thyroid tumors or a type of thyroid cancer called medullary thyroid carcinoma (MTC) in people.
- Do not use BYDUREON BCISE if you or any of your family have ever had a type of thyroid cancer called medullary thyroid carcinoma (MTC), or if you have an endocrine system condition called Multiple Endocrine Neoplasia syndrome type 2 (MEN 2).

What is BYDUREON BCISE?

- BYDUREON BCISE is an injectable prescription medicine that may improve blood sugar (glucose) in adults with type 2 diabetes mellitus and should be used along with diet and exercise.
- BYDUREON BCISE is not recommended as the first choice of medicine for treating diabetes.
- BYDUREON BCISE is not a substitute for insulin and is not for use in people with type 1 diabetes or people with diabetic ketoacidosis.
- It is not known if BYDUREON BCISE can be used with mealtime insulin.
- BYDUREON BCISE and BYDUREON are long-acting forms of the medicine in BYETTA (exenatide). BYDUREON BCISE should not be used at the same time as BYETTA or BYDUREON.
- It is not known if BYDUREON BCISE can be used in people who have had pancreatitis.
- It is not known if BYDUREON BCISE is safe and effective for use in children.

Do not use BYDUREON BCISE if:

- you or any of your family have ever had a type of thyroid cancer called medullary thyroid carcinoma (MTC) or if you have an endocrine system condition called Multiple Endocrine Neoplasia syndrome type 2 (MEN 2).
- you have a history of low blood platelet count from using exenatide medicines (drug-induced thrombocytopenia).
- you are allergic to exenatide or any of the ingredients in BYDUREON BCISE. See the end of this Medication Guide for a complete list of ingredients in BYDUREON BCISE.

Before using BYDUREON BCISE, tell your healthcare provider about all of your medical conditions, including if you:

- have or have had problems with your pancreas or kidneys.
- have severe problems with your stomach, such as slowed emptying of your stomach (gastroparesis) or problems with digesting food.
- are pregnant or plan to become pregnant. BYDUREON BCISE may harm your unborn baby. Tell your healthcare provider if you become pregnant while using BYDUREON BCISE. Talk to your healthcare provider about the best way to control your blood sugar if you plan to become pregnant or while you are pregnant.
- are breastfeeding or plan to breastfeed. It is not known if BYDUREON BCISE passes into your breast milk. You should talk with your healthcare provider about the best way to feed your baby while using BYDUREON BCISE.

Tell your healthcare provider about all the medicines you take, including prescription and over-the-counter medicines, vitamins, and herbal supplements. BYDUREON BCISE may affect the way some medicines work and some medicines may affect the way BYDUREON BCISE works.

Before using BYDUREON BCISE, talk to your healthcare provider about low blood sugar and how to manage it. Tell your healthcare provider if you are taking other medicines to treat diabetes including insulin or sulfonylureas.

Know the medicines you take. Keep a list of them to show your healthcare provider and pharmacist when you get a new medicine.

How should I use BYDUREON BCISE?

- Read the **Instructions for Use** that comes with BYDUREON BCISE.
- Use BYDUREON BCISE exactly as your healthcare provider tells you to.
- BYDUREON BCISE should be injected right away after you prepare your dose.
- **Your healthcare provider should show you how to use BYDUREON BCISE before you use it for the first time.**
- BYDUREON BCISE is injected under the skin (subcutaneously) of your stomach (abdomen), thigh, or upper arm. **Do not** inject BYDUREON BCISE into a muscle (intramuscularly) or vein (intravenously).
- **Use BYDUREON BCISE 1 time each week on the same day each week at any time of the day.**
- BYDUREON BCISE may be taken with or without food.
- If you miss a dose of BYDUREON BCISE, take the missed dose as soon as possible if there are at least 3 days (72 hours) until your next scheduled dose. If there are less than 3 days remaining, skip the missed dose and take your next dose on the regularly scheduled day. **Do not** take 2 doses of BYDUREON BCISE within 3 days of each other.
- You may change the day of the week as long as your last dose was given 3 or more days before.
- If you use a different long acting exenatide medicine and your healthcare provider switches your medicine to BYDUREON BCISE, you should start using BYDUREON BCISE at your next scheduled dose.
- **Do not** mix insulin and BYDUREON BCISE together in the same injection.
- You may give an injection of BYDUREON BCISE and insulin in the same body area (such as, your stomach area), but not right next to each other.
- Change (rotate) your injection site with each weekly injection. **Do not** use the same site for each injection.
- **Your dose of other diabetes medicines may need to change because of:** change in level of physical activity or exercise, weight gain or loss, increased stress, illness, change in diet, or because of other medicines you take.
- **Do not share** your BYDUREON BCISE with another person. You may give another person an infection or get an infection from them.

What are the possible side effects of BYDUREON BCISE?

BYDUREON BCISE may cause serious side effects, including:

- **See "What is the most important information I should know about BYDUREON BCISE?"**
- **inflammation of your pancreas (pancreatitis).** Stop using BYDUREON BCISE and call your healthcare provider right away if you have severe pain in your stomach area (abdomen) that will not go away, with or without vomiting. You may feel the pain from your abdomen to your back.
- **low blood sugar (hypoglycemia).** Your risk for getting low blood sugar may be higher if you use BYDUREON BCISE with another medicine that can cause low blood sugar, such as a sulfonylurea or insulin. **Signs and symptoms of low blood sugar may include:**
 - dizziness or light-headedness
 - blurred vision
 - anxiety, irritability, or mood changes
 - sweating
 - slurred speech
 - hunger
 - confusion or drowsiness
 - shakiness
 - weakness
 - headache
 - fast heartbeat
 - feeling jittery
- **kidney problems.** In people who have kidney problems, diarrhea, nausea, and vomiting may cause a loss of fluids (dehydration) which may cause kidney problems to get worse or kidney failure.
- **stomach problems.** Other medicines like BYDUREON BCISE may cause severe stomach problems. It is not known if BYDUREON BCISE causes or worsens stomach problems.
- **low blood platelet count (drug-induced thrombocytopenia).** BYDUREON BCISE may cause the number of platelets in your blood to be reduced. When your platelet count is too low, your body cannot form blood clots. You could have serious bleeding that could lead to death. **Stop using BYDUREON BCISE and call your healthcare provider right away if you have unusual bleeding or bruising.** Your blood platelet count may continue to be low for about 10 weeks after stopping BYDUREON BCISE.
- **serious allergic reactions.** Stop using BYDUREON BCISE and get medical help right away if you have any symptoms of a serious allergic reaction, including itching, rash, or difficulty breathing.

- **injection-site reactions.** Serious injection-site reactions, with or without bumps (nodules), have happened in some people who use BYDUREON. Some of these injection-site reactions have required surgery. Call your healthcare provider if you have any symptoms of an injection-site reaction, including severe pain, swelling, blisters, an open wound, a dark scab.
- **gallbladder problems.** Gallbladder problems have happened in some people who take BYDUREON or other medicines like BYDUREON. Tell your healthcare provider right away if you get symptoms of gallbladder problems which may include: pain in the right or middle upper stomach area, nausea and vomiting, fever, or your skin or the white part of your eyes turns yellow.

The most common side effects of BYDUREON BCISE may include a bump (nodule) at the injection site and nausea.

Nausea is most common when you first start using BYDUREON BCISE but decreases over time in most people as their body gets used to the medicine.

Talk to your healthcare provider about any side effect that bothers you or does not go away.

These are not all the possible side effects of BYDUREON BCISE.

Call your doctor for medical advice about side effects. You may report side effects to FDA at 1-800-FDA-1088.

Keep BYDUREON BCISE and all medicines out of the reach of children.

General information about the safe and effective use of BYDUREON BCISE.

Medicines are sometimes prescribed for purposes other than those listed in a Medication Guide. Do not use BYDUREON BCISE for a condition for which it was not prescribed. Do not give your BYDUREON BCISE to other people, even if they have the same symptoms you have. It may harm them.

You can ask your pharmacist or healthcare provider for information about BYDUREON BCISE that is written for health professionals.

What are the ingredients in BYDUREON BCISE?

Contents of the powder:

Active Ingredient: exenatide

Inactive Ingredients: polylactide-co-glycolide and sucrose

Contents of liquid (diluent):

Inactive Ingredients: medium chain triglycerides

BYDUREON, BCISE and BYETTA are trademarks of the AstraZeneca group of companies. All other marks are the marks of their respective owners.

Manufactured for:

AstraZeneca Pharmaceuticals LP

Wilmington, DE 19850

By:

Amylin Ohio LLC

West Chester, OH 45071 and

Vetter Pharma-Fertigung GmbH & Co. KG

88214 Ravensburg

Germany

For more information about BYDUREON BCISE, go to www.BYDUREONBCISE.com or call 1-877-700-7365.

This Medication Guide has been approved by the U.S. Food and Drug Administration.

Revised: February 2020

INSTRUCTIONS FOR USE

Once-weekly BYDUREON BCISE®

(exenatide extended-release), injectable suspension

For subcutaneous use only

Single-dose Autoinjector once weekly

2 mg



Read the Instructions for Use before you start using BYDUREON BCISE.

Before using BYDUREON BCISE, talk to your healthcare provider about how to use it the right way.

Before You Begin

The autoinjector:

- Is a single use, fixed dose autoinjector that automatically injects your medicine.
 - Is injected 1 time per week under the skin.
 - Comes in the locked position before you use it. Do not unlock the autoinjector until you are ready to inject it.
 - Needle is hidden. You do not see it before, during, or after using the autoinjector.
- **Do not** use the autoinjector if any parts look to be broken or damaged.
 - Store flat in the refrigerator between 36°F to 46°F (2°C to 8°C).
 - Never share your BYDUREON BCISE autoinjector with anyone else. You may give an infection to them or get an infection from them.
 - BYDUREON BCISE should **not** be used by people who are blind or cannot see well, unless another person who is trained to use this device can help.
 - Keep the autoinjector, and all medicines, out of the reach of children.

Before Use



Figure A

Supplies needed to give your injection:

BYDUREON BCISE autoinjector, Alcohol swab, A clean, flat surface, Sharps container (see “disposal” instructions at the end of these instructions)

Step 1: Prepare for Injection

A. Let your autoinjector come to room temperature.

Remove 1 autoinjector from the refrigerator and rest it flat for 15 minutes. Autoinjector can be kept at room temperature for up to 4 weeks.



Figure B

B. Check the expiration date (labeled EXP) printed on the autoinjector label.

Do not use the autoinjector past the expiration date. If the expiration date has passed, throw it away and get a new autoinjector.



Figure C

C. Wash your hands.

D. Choose your injection site.

You can inject into your stomach, thigh, or back of the upper arm, see Figure D.

Each week you can use the same area of your body, but choose a different injection site in that area of your body.

Clean the area with an alcohol swab.

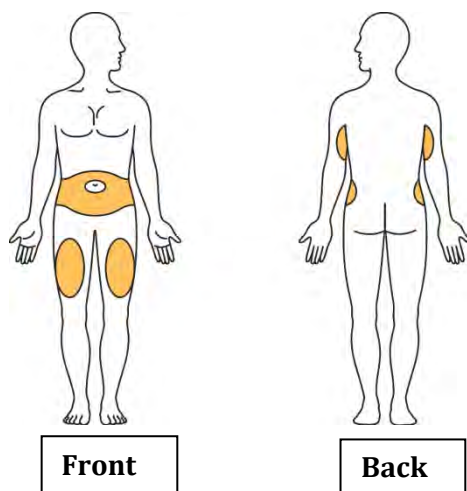

Figure D

Step 2: Mix the medicine

A. Look in the window.

You may see white medicine along the sides, bottom or top. This means the medicine is not mixed evenly.

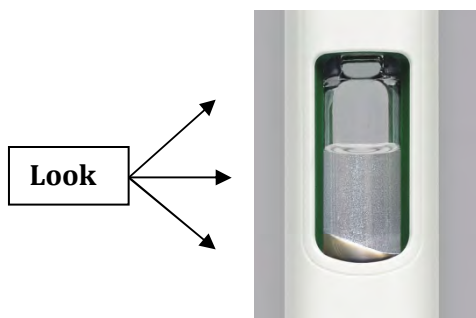

Figure E

B. Shake the autoinjector hard,

in an up-and-down motion, until the medicine is mixed evenly and you do not see any white medicine along the sides, bottom or top. Shake for at least 15 seconds. The autoinjector may need to be shaken longer than 15 seconds if the autoinjector has not been correctly stored flat.

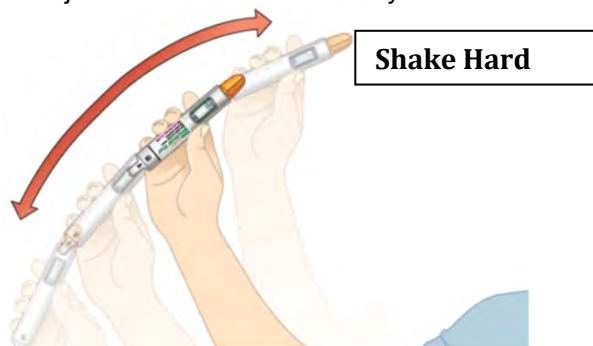

Figure F

C. Check the mix.

Hold the autoinjector up to the light and look through both sides and the bottom of the window. If not mixed well, repeat Step 2 and check again.

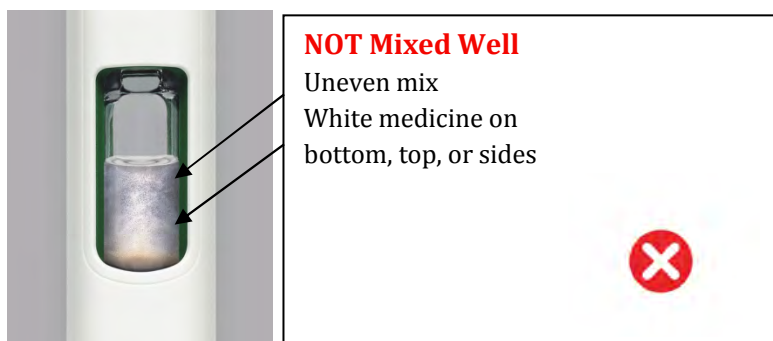

Figure G

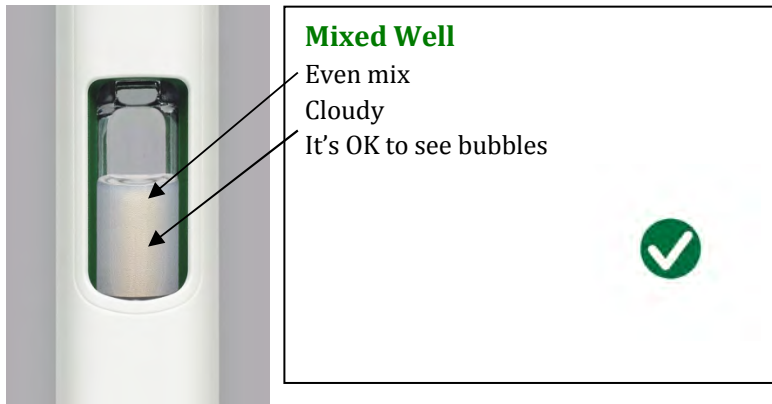

Figure H



Do not go to the next step unless your medicine is mixed well. To get a full dose, the medicine must be mixed well and look cloudy.
If not mixed well, continue to shake hard.

Step 3: Prepare the Autoinjector

Important: After the medicine is fully mixed, you must complete the preparation steps **right away**, and inject to get the full dose. Do not save it to use later.

Only unlock the autoinjector when you are ready to inject

A. Unlock the autoinjector.

Hold the autoinjector up straight with the orange cap toward the ceiling. Turn the knob from the Lock to the Unlock position until you hear a click.



Figure I

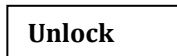

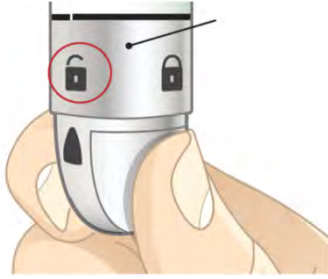

Figure J

B. While still holding the autoinjector straight up, firmly unscrew the orange cap.

- You may need to turn the cap a few times before it loosens (if you hear clicking you are turning in the wrong direction).
 - Continue holding the autoinjector upright to prevent the medicine from accidentally leaking.
 - A green shield will pop up after the cap is removed. The green shield hides the needle.
- It is normal to see a few drops of liquid inside the cap. **Do not** recap the autoinjector. Throw away the cap.

Hold **upright** and **firmly** unscrew in a counterclockwise direction.



Figure K



Figure L

Removed Cap



Figure M

Green shield **pops** up

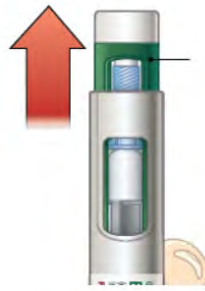

Hidden Needle

Figure N

Step 4: Inject the Dose

A. Inject and hold:

- Push the autoinjector against your skin. You will hear a “click” when the injection begins.
- Keep holding the autoinjector against the skin for 15 seconds. This is to make sure you get the full dose.



Figure O

B. Make sure you received your full dose.

After you receive your injection, you will see an orange rod in the window. After you lift the autoinjector from your skin, the green shield will move back up to lock over the needle. See the Common Questions and Answers for what to do if you do not see the orange rod after injection.

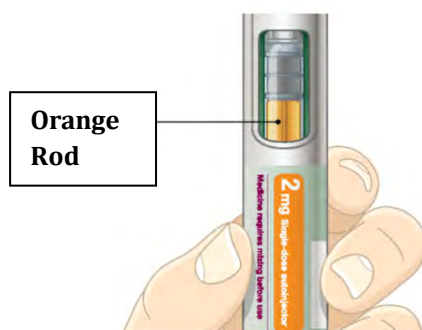

Figure P

Step 4: Inject the Dose (continued)

C. Disposal.

Put your used autoinjector in a FDA-cleared sharps disposal container right away after use. Do not throw away (dispose of) loose needles and syringes into your household trash. If you do not have an FDA-cleared sharps disposal container, you may use a household container that is:

- Made of heavy-duty plastic
- Can be closed with a tight-fitting, puncture-resistant lid that will not let sharps come out.
- Upright and stable during use
- Leak-resistant, and
- Properly labeled to warn of hazardous waste inside the container



Figure Q

When your sharps disposal container is almost full, you will need to follow your community guidelines for the right way to dispose of your sharps disposal container. There may be state or local laws about how you should throw away used needles and syringes. For more information about safe sharps disposal, and for specific information about sharps disposal in the state that you live in, go to FDA's website at: <http://www.fda.gov/safesharpsdisposal>.

Do not dispose of your used sharps disposal container in your household trash unless your community guidelines permit this. Do not recycle your used sharps disposal container. See "Common Questions and Answers" for additional disposal information.

Please keep these instructions to use for your next dose.

Common Questions and Answers

1. Where is the needle?

The needle is attached to the autoinjector and covered by the orange cap.

When you unscrew the orange cap, the green shield keeps the needle covered until you inject.

For more information, please see Figure N in Step 3B in the Instructions for Use.

2. How do I know if the medicine is fully mixed?

After shaking the autoinjector, look through both sides of the window. You should not see any white medicine along the bottom, top, or sides. If you see white medicine, it is unmixed. To mix, shake the autoinjector hard until the white medicine is no longer on the bottom, top, or sides. The medicine should look even throughout.

3. Why do I need to hold the autoinjector upright while removing the orange cap?

Holding the autoinjector with the orange cap straight up helps prevent the medicine from leaking. It is normal to see a few drops of medicine inside the orange cap after you unscrew it.

4. Why should I inject my medicine right away after mixing it?

If you do not inject your medicine right away after mixing, the medicine may separate, and you will not get your full dose. You can re-mix your medicine if your autoinjector is in the locked position. However, after you unlock it, you must complete the preparation steps right away and inject to get the full dose. You cannot save it for later use.

5. How do I know I gave myself the full dose of medicine?

To be sure you get your full dose, press and hold the autoinjector against your skin.

You will feel the needle go into your skin. Hold the needle against your skin for 15 seconds. This will allow enough time for all the medicine to go from the autoinjector to under your skin. After removing the needle,

look for the orange rod in the window as a way to tell that the dose has been given. If the orange rod does not appear contact Customer Service at 1-877-700-7365.

6. Why should I store my autoinjectors flat in the refrigerator?

Autoinjectors stored vertically (with the needle up or down) are more difficult to mix. The medicine can still be fully mixed, but it will take more shaking and more time.

7. What if I do not have an FDA-cleared sharps disposal container?

Do not throw away (dispose of) the autoinjector in your household trash. If you do not have an FDA-cleared sharps disposal container, you may use a household container that is:

- Made of heavy-duty plastic
- Can be closed with a tight-fitting, puncture-resistant lid, that won't let sharps come out
- Upright and stable during use
- Leak-resistant
- Properly labeled to warn of hazardous waste inside the container

When your sharps disposal container is almost full, you will need to follow your community guidelines for the right way to dispose of your sharps disposal container. There may be state or local laws about how you should throw away used needles and autoinjectors.

For more information about safe sharps disposal, and for specific information about sharps disposal in the state you live in, go to the FDA's website at: <http://www.fda.gov/safesharpsdisposal>.

8. What if I cannot unlock the autoinjector?

Review the Instructions for Use Step 3 to make sure you are following the right instructions, then contact Customer Service, 1-877-700-7365 for help as needed. Do not try to unlock with excessive force or tools.

9. What if I cannot remove the orange cap from the autoinjector?

Review the Instructions for Use Step 3 to make sure you are following the right instructions. You should also check that the knob is fully in the unlocked position, then contact Customer Service, 1-877-700-7365 for help as needed. Do not use tools or try to force the cap off.

10. For other questions about BYDUREON BCISE:

Visit www.BydureonBCise.com.

Call Customer Service at 1-877-700-7365.

How to Store BYDUREON BCISE Autoinjector

- Store the autoinjector flat in the refrigerator between 36°F to 46°F (2°C to 8°C).
- Each autoinjector can be kept at room temperature not to exceed 86°F (30°C) for no more than a total of 4 weeks, if needed.
- Store in the packaging provided to protect from light until you are ready to prepare and use your dose.
- Do not use the autoinjector past the expiration date. The expiration date is labeled EXP.
- Keep the autoinjector clean and away from spills.

This Instructions for Use has been approved by the U.S. Food and Drug Administration. Revised: 7/2019

PRODUCT MONOGRAPH
INCLUDING PATIENT MEDICATION INFORMATION

^{Pr}CABOMETRYX™
cabozantinib tablets

Tablets, 20 mg, 40 mg, 60 mg cabozantinib (as cabozantinib (S)-malate), Oral

Antineoplastic
ATC Code: L01XE26

Ipsen Biopharmaceuticals Canada Inc.
5060 Spectrum Way, 5th Floor
Mississauga, ON L4W 5N5

Date of Revision:
May 7, 2020

Submission Control No: 237444

CABOMETRYX is a trademark of Exelixis, Inc., licensed to Ipsen Pharma S.A.S.

RECENT MAJOR LABEL CHANGES

WARNINGS AND PRECAUTIONS (7)
PATIENT MEDICATION INFORMATION

05-2020
05-2020

TABLE OF CONTENTS

RECENT MAJOR LABEL CHANGES	2
TABLE OF CONTENTS	2
PART I: HEALTH PROFESSIONAL INFORMATION	4
1 INDICATIONS	4
1.1 Pediatrics.....	4
1.2 Geriatrics.....	4
2 CONTRAINDICATIONS	4
3 SERIOUS WARNINGS AND PRECAUTIONS	5
4 DOSAGE AND ADMINISTRATION	5
4.1 Recommended Dose and Dosage Adjustment.....	5
4.2 Administration	6
4.3 Missed Dose.....	6
5 OVERDOSAGE	6
6 DOSAGE FORMS, STRENGTHS, COMPOSITION AND PACKAGING	6
7 WARNINGS AND PRECAUTIONS	7
7.1 Special Populations.....	12
7.1.1 Pregnant Women.....	12
7.1.2 Breast-feeding	12
7.1.3 Pediatrics	13
7.1.4 Geriatrics (> 65 years of age).....	13
8 ADVERSE REACTIONS	13
8.1 Adverse Reaction Overview	13
8.2 Clinical Trial Adverse Reactions	14
8.3 Less Common Clinical Trial Adverse Reactions (2%).....	20
8.4 Abnormal Laboratory Findings: Hematologic, Clinical Chemistry and Other Quantitative Data	20
8.5 Post-Market Adverse Drug Reactions	21
9 DRUG INTERACTIONS	21
9.1 Overview.....	21
9.2 Drug-Drug Interactions.....	21
9.3 QTc Interval-Prolonging Drugs	22
10 ACTION AND CLINICAL PHARMACOLOGY	23
10.1 Mechanism of Action.....	23
10.2 Pharmacodynamics.....	23
10.3 Pharmacokinetics	24

11	STORAGE, STABILITY AND DISPOSAL.....	25
12	PHARMACEUTICAL INFORMATION	26
13	CLINICAL TRIALS	27
13.1	Trial Design and Study Demographics	27
14	NON-CLINICAL TOXICOLOGY	35
	PATIENT MEDICATION INFORMATION.....	37

PART I: HEALTH PROFESSIONAL INFORMATION

1 INDICATIONS

Renal Cell Carcinoma (RCC)

CABOMETRYX (cabozantinib) is indicated for the treatment of advanced RCC:

- In treatment-naïve adults with intermediate or poor risk.
- In adult patients who have received prior vascular endothelial growth factor (VEGF)-targeted therapy.

Hepatocellular Carcinoma (HCC)

CABOMETRYX is indicated for the treatment of patients with HCC who have been previously treated with sorafenib.

1.1 Pediatrics

Pediatrics (<18 years of age): No data are available to Health Canada; therefore, Health Canada has not authorized an indication for pediatric use.

1.2 Geriatrics

Geriatrics (> 65 years of age): Evidence from clinical studies and experience suggests that use in the geriatric population is associated with no differences in safety or effectiveness.

2 CONTRAINDICATIONS

CABOMETRYX (cabozantinib) is contraindicated in patients who are hypersensitive to this drug or to any ingredient in the formulation, including any non-medicinal ingredient, or component of the container. For a complete listing, see [DOSAGE FORMS, STRENGTHS, COMPOSITION AND PACKAGING](#).

3 SERIOUS WARNINGS AND PRECAUTIONS

Serious Warnings and Precautions

Treatment with CABOMETYX (cabozantinib) should be initiated and supervised by a physician experienced in the use of anti-cancer medicinal products.

CABOMETYX has not been studied in patients with cardiac impairment.

CABOMETYX has not been studied in patients with severe renal impairment.

CABOMETYX has not been studied in patients with severe hepatic impairment.

The following are clinically significant adverse events:

- Thromboembolism, including deaths (see [WARNINGS AND PRECAUTIONS, Cardiovascular](#))
- Hypertension and hypertensive crisis (see [WARNINGS AND PRECAUTIONS, Cardiovascular](#))
- Gastrointestinal perforations and fistulas, including deaths (see [WARNINGS AND PRECAUTIONS, Gastrointestinal](#))
- Hemorrhage, including deaths (see [WARNINGS AND PRECAUTIONS, Hematologic](#))
- Hepatotoxicity (see [WARNINGS AND PRECAUTIONS, Hepatic](#))
- Reversible Posterior Leukoencephalopathy Syndrome (see [WARNINGS AND PRECAUTIONS, Neurologic](#))
- Wound complications (see [WARNINGS AND PRECAUTIONS, Peri-Operative Considerations](#))

4 DOSAGE AND ADMINISTRATION

4.1 Recommended Dose and Dosage Adjustment

The recommended daily dose of CABOMETYX (cabozantinib) is 60 mg. Continue treatment until patient no longer experiences clinical benefit or experiences unacceptable toxicity.

For Patients Undergoing Surgery

Stop treatment with CABOMETYX at least 28 days prior to scheduled surgery, including dental surgery (see [WARNINGS AND PRECAUTIONS, Peri-Operative Considerations](#)).

For Adverse Reactions

Management of suspected adverse drug reactions may require temporary treatment interruption and/or dose reduction of CABOMETYX therapy. When dose reduction is necessary, it is recommended to reduce to 40 mg daily, and then to 20 mg daily. Dose interruptions are recommended for management of CTCAE grade 3 or greater toxicities or intolerable grade 2 toxicities. Dose reductions are recommended for events that, if persistent, could become serious or intolerable.

Discontinue CABOMETYX for any of the following:

- development of unmanageable fistula or GI perforation
- severe hemorrhage
- arterial thromboembolic event (e.g., myocardial infarction, cerebral infarction)

- hypertensive crisis or severe hypertension despite optimal medical management
- nephrotic syndrome
- reversible posterior leukoencephalopathy syndrome

In Patients with Hepatic Impairment

Reduce the starting dose of CABOMETYX to 40 mg once daily in patients with mild or moderate hepatic impairment. CABOMETYX is not recommended for use in patients with severe hepatic impairment (see [ACTION AND CLINICAL PHARMACOLOGY, Pharmacokinetics](#)). Patients with mild or moderate hepatic impairment should be closely monitored.

In Patients with Renal Impairment

CABOMETYX should be used with caution in patients with mild or moderate renal impairment. CABOMETYX is not recommended for use in patients with severe renal impairment as safety and efficacy have not been established in this population (see [ACTION AND CLINICAL PHARMACOLOGY, Pharmacokinetics](#)).

Health Canada has not authorized an indication for pediatric use.

4.2 Administration

Swallow CABOMETYX tablets whole. Do not crush CABOMETYX tablets.

Do **not** administer CABOMETYX with food. Instruct patients not to eat for at least 2 hours before and at least 1 hour after taking CABOMETYX.

Do not ingest foods (e.g., grapefruit, grapefruit juice) or nutritional supplements that are known to inhibit cytochrome P450 during CABOMETYX treatment.

4.3 Missed Dose

Do not take a missed dose within 12 hours of the next dose.

5 OVERDOSAGE

There is no specific treatment for CABOMETYX (cabozantinib) overdose and possible symptoms of overdose have not been established.

In the event of suspected overdose, CABOMETYX should be withheld and supportive care instituted. Liver function tests, serum electrolytes and metabolic clinical laboratory parameters should be monitored at least weekly or as deemed clinically appropriate to assess any possible changing trends. Blood pressure and ECG monitoring are recommended. Adverse reactions associated with overdose are to be treated symptomatically.

For management of a suspected drug overdose, contact your regional poison control centre.

6 DOSAGE FORMS, STRENGTHS, COMPOSITION AND PACKAGING

Table 1: Dosage Forms, Strengths, Composition and Packaging.

Route of	Dosage Form /	Non-medicinal Ingredients
----------	---------------	---------------------------

Administration	Strength/Composition	
oral	tablet 20 mg, 40 mg, 60 mg cabozantinib as cabozantinib (S)-malate	Colloidal Silicon Dioxide, Croscarmellose Sodium, Hydroxypropyl Cellulose, Hypromellose 2910, Iron Oxide Yellow, Lactose Anhydrous, Magnesium Stearate, Microcrystalline Cellulose, Titanium Dioxide and Triacetin.

60 mg tablets are yellow film-coated, oval shaped with no score, debossed with “XL” on one side and “60” on the other side of the tablet; available in bottles of 30 tablets.

40 mg tablets are yellow film-coated, triangle shaped with no score, debossed with “XL” on one side and “40” on the other side of the tablet; available in bottles of 30 tablets.

20 mg tablets are yellow film-coated, round shaped with no score, debossed with “XL” on one side and “20” on the other side of the tablet; available in bottles of 30 tablets.

7 WARNINGS AND PRECAUTIONS

General

As most events can occur early in the course of treatment, the physician should evaluate the patient closely during the first eight weeks of treatment to determine if dose modifications are warranted. Events that generally have early onset include hypocalcemia, hypokalemia, thrombocytopenia, hypertension, palmar-plantar erythrodysesthesia syndrome (PPES), proteinuria, and gastrointestinal (GI) events (abdominal pain, mucosal inflammation, constipation, diarrhea, vomiting).

Carcinogenesis and Mutagenesis

There are no human data on carcinogenesis and mutagenesis. Based on non-clinical findings, the long-term carcinogenic potential of CABOMETYX (cabozantinib) is unknown (see [NON-CLINICAL TOXICOLOGY, Carcinogenicity](#)).

Cardiovascular

Thrombotic Events

CABOMETYX treatment results in an increased incidence of thrombotic events. In RCC studies, venous thromboembolism occurred in 9% (including 5% pulmonary embolism) and arterial thromboembolism occurred in 1% of CABOMETYX-treated patients. In the pivotal HCC study (XL184-309), portal vein thrombosis was observed in 1% (including one fatal event) of CABOMETYX-treated patients. Patients with a history of portal vein invasion appeared to be at higher risk of developing portal vein thrombosis. Arterial thromboembolism occurred in 3% of CABOMETYX-treated HCC patients; most frequently occurred cerebrovascular accident (1% CABOMETYX vs 0% placebo) including one fatal event. In addition, two other subjects in the CABOMETYX arm had Grade 5 arterial thrombotic AEs and two had Grade 5 venous/mixed thrombotic AEs.

Use CABOMETYX with caution in patients who are at risk for, or who have a history of these events. Discontinue CABOMETYX in patients who develop an acute myocardial infarction or any other clinically significant arterial thromboembolic complication (see [DOSAGE AND ADMINISTRATION](#)).

Hypertension and Hypertensive Crisis

CABOMETYX treatment results in an increased incidence of treatment-emergent hypertension, including hypertensive crisis. In RCC studies, hypertension was reported in 44% (18% Grade \geq 3) of CABOMETYX-treated patients. In the pivotal HCC study, hypertension events were reported in 30% (16% Grade \geq 3) of CABOMETYX-treated patients.

Serious cases of artery dissection have been reported in patients using VEGF receptor tyrosine kinase inhibitors (VEGFR TKIs), including CABOMETYX, with or without hypertension.

Blood pressure should be well controlled prior to initiating CABOMETYX. Monitor blood pressure prior to initiation and regularly during CABOMETYX treatment. Reduce the dose of CABOMETYX for hypertension that is not adequately controlled by medical management; when controlled, resume CABOMETYX at a reduced dose. Discontinue CABOMETYX for severe hypertension that cannot be controlled with anti-hypertensive therapy. Discontinue CABOMETYX in the case of hypertensive crisis or severe hypertension despite optimal medical management (see [DOSAGE AND ADMINISTRATION](#)).

Prolongation of QT interval

CABOMETYX causes a prolongation of the QTc interval (see [ACTION AND CLINICAL PHARMACOLOGY, Cardiac Electrophysiology](#)). QTc prolongation may lead to an increased risk of ventricular arrhythmias including torsade de pointes. Torsade de pointes is a polymorphic ventricular tachyarrhythmia. Generally, the risk of torsade de pointes increases with the magnitude of QTc prolongation produced by the drug. Torsade de pointes may be asymptomatic or experienced by the patient as dizziness, palpitations, syncope, or seizures. If sustained, torsade de pointes can progress to ventricular fibrillation and sudden cardiac death. Hypokalemia, hypomagnesemia, and hypocalcemia should be corrected prior to initiating or continuing CABOMETYX administration.

Particular care should be exercised when administering CABOMETYX to patients who are taking other medicinal products known to prolong the QTc interval (see [DRUG INTERACTIONS](#)) or who are suspected to be at an increased risk of experiencing torsade de pointes during treatment with a QTc-prolonging drug.

Risk factors for torsade de pointes in the general population include, but are not limited to, the following: female gender, age \geq 65 years, baseline prolongation of the QT/QTc interval; presence of genetic variants affecting cardiac ion channels or regulatory proteins, especially congenital long QT syndromes; family history of sudden cardiac death at $<$ 50 years of age; cardiac disease (e.g., myocardial ischemia or infarction, congestive heart failure, cardiomyopathy, conduction system disease); history of arrhythmias; electrolyte disturbances (e.g., hypokalemia, hypomagnesemia, hypocalcemia) or conditions leading to electrolyte disturbances (e.g., persistent vomiting, eating disorders); bradycardia; acute neurological events (e.g., intracranial or subarachnoid haemorrhage, stroke, intracranial trauma); diabetes mellitus; and autonomic neuropathy.

Monitor electrocardiogram and electrolytes regularly. Permanently discontinue CABOMETYX in patients who develop torsade de pointes or polymorphic ventricular tachycardia or signs/symptoms of serious arrhythmia.

When drugs that prolong the QTc interval are prescribed, healthcare professionals should counsel their patients concerning the nature and implications of the ECG changes, underlying diseases and disorders that are considered to represent risk factors, demonstrated and predicted drug-drug interactions, symptoms suggestive of arrhythmia, risk management strategies, and

other information relevant to the use of the drug. Patients should be advised to contact their healthcare provider immediately to report any new chest pain or discomfort, changes in heartbeat, palpitations, dizziness, lightheadedness, fainting, or changes in or new use of other medications.

Heart Rate Decrease and PR Interval Prolongation

CABOMETYX causes a decrease in heart rate and a prolongation of the PR interval (see [ACTION AND CLINICAL PHARMACOLOGY, Cardiac Electrophysiology](#)). Caution should be observed in patients with a low heart rate at baseline (< 60 beats per minute), a history of syncope or arrhythmia, sick sinus syndrome, sinoatrial block, atrioventricular (AV) block, ischemic heart disease, or congestive heart failure. Concomitant medications that result in a decrease in heart rate and/or PR interval prolongation should be avoided to the extent possible during treatment with CABOMETYX (see [DRUG INTERACTIONS](#)).

Driving and Operating Machinery

Adverse events such as fatigue, dizziness and weakness occurred in CABOMETYX-treated patients. Caution should be exercised when driving or operating a vehicle or potentially dangerous machinery.

Endocrine

Thyroid dysfunction

Hypothyroidism occurred in 21% of RCC patients treated with CABOMETYX. Monitoring for thyroid function before initiation of, and periodically throughout, treatment with CABOMETYX is recommended. Hypothyroidism should be treated according to standard medical practice to maintain euthyroid state.

Gastrointestinal (GI)

Diarrhea

Diarrhea occurred in 74% of patients treated with CABOMETYX. Grade 3 diarrhea was reported in 11% of CABOMETYX-treated patients. Withhold CABOMETYX in patients that develop intolerable Grade 2 diarrhea or Grade 3-4 diarrhea that cannot be managed with standard antidiarrheal treatments until improvement to Grade 1; resume CABOMETYX at a reduced dose. Dose interruption or reduction, or permanent discontinuation of CABOMETYX should be considered in case of persistent or recurrent significant GI adverse reactions. Dose modification due to diarrhea occurred in 26% of RCC patients previously treated with VEGF-targeted therapy (see [DOSAGE AND ADMINISTRATION](#)).

GI Perforation and Fistulas

Serious GI perforations and fistulas, sometimes fatal, have been observed with CABOMETYX. Fistulas were reported in 1% (including 0.6% anal fistula) of CABOMETYX-treated patients and GI perforations were reported in 1% of patients treated with CABOMETYX. In the pivotal HCC study, fistulas occurred in 2% of CABOMETYX-treated patients including a fatal case of esophagobronchial fistula. Patients who have inflammatory bowel disease (e.g. Crohn's disease, ulcerative colitis, peritonitis, diverticulitis, or appendicitis), have tumour infiltration in the GI tract, or have complications from prior GI surgery (particularly when associated with delayed or incomplete healing) should be carefully evaluated before initiating CABOMETYX therapy. Persistent or recurring diarrhea while on treatment may be a risk factor for the development of anal fistula. Monitor patients for symptoms of fistulas and perforations. Discontinue CABOMETYX in patients who experience a GI perforation or a fistula that cannot be adequately managed (see [DOSAGE AND ADMINISTRATION](#)).

Hematologic

Hemorrhage

Severe hemorrhage, sometimes fatal, occurred with CABOMETYX. In two pivotal RCC studies (XL184-308 and A031203), the incidence of Grade ≥ 3 hemorrhagic events was 3%. Discontinue CABOMETYX in patients who experience severe hemorrhage (see [DOSAGE AND ADMINISTRATION](#)).

Patients who have a history of severe bleeding prior to treatment initiation should be carefully evaluated before initiating CABOMETYX therapy. CABOMETYX should not be administered to patients that have or are at risk for severe hemorrhage.

In the pivotal HCC study, fatal hemorrhagic events were reported at a higher incidence with CABOMETYX than with placebo (1% vs 0%). Predisposing risk factors for severe hemorrhage in the advanced HCC population may include tumour invasion of major blood vessels and the presence of underlying liver cirrhosis resulting in oesophageal varices, portal hypertension, and thrombocytopenia. The study excluded patients with concomitant anticoagulation treatment or antiplatelet agents. Subjects with untreated, or incompletely treated, varices with bleeding or high risk for bleeding were also excluded from this study.

Thrombocytopenia

In the pivotal HCC study, thrombocytopenia (11%) and decreased platelets (10%) were reported with CABOMETYX. Platelet levels should be monitored during CABOMETYX treatment and the dose modified according to the severity of the thrombocytopenia.

Hepatic/Biliary/Pancreatic

Hepatotoxicity

In RCC patients previously treated with VEGF-targeted therapy (XL184-308), increases in alanine aminotransferase (ALT) and aspartate aminotransferase (AST) were reported in 24% and 26% CABOMETYX-treated RCC patients respectively (see [ADVERSE REACTIONS](#)). Grade 3 or higher ALT and AST increases were also observed in 3% and 2% of RCC subjects treated with CABOMETYX. Fatal hepatic failure has occurred in the CABOMETYX clinical program. Hepatitis, hepatic failure and hepatic encephalopathy have been reported in the post market setting.

Monitoring of ALT, AST and bilirubin before initiation of, and periodically throughout treatment with CABOMETYX is recommended.

Hepatic Encephalopathy

In the pivotal HCC study, hepatic encephalopathy was reported more frequently in the CABOMETYX arm (4%) than in the placebo arm (1%). CABOMETYX has been associated with diarrhea, vomiting, decreased appetite and electrolyte abnormalities. In HCC patients with compromised livers, these non-hepatic effects may be precipitating factors for the development of hepatic encephalopathy. Patients should be monitored for signs and symptoms of hepatic encephalopathy.

Monitoring and Laboratory Tests

Cardiac Safety Monitoring

Patients receiving CABOMETYX should be monitored for heart rate and blood pressure. ECG evaluations should be performed prior to initiating therapy and periodically during treatment to monitor for QTc and PR interval prolongation (see [WARNINGS AND PRECAUTIONS, Cardiovascular](#), [ACTION AND CLINICAL PHARMACOLOGY](#), [Cardiac Electrophysiology](#)).

Electrolyte Monitoring

Electrolyte levels (calcium, potassium, and magnesium) should be assessed at baseline and monitored regularly during treatment with CABOMETYX, particularly in patients at risk for these electrolyte abnormalities (see [WARNINGS AND PRECAUTIONS, Cardiovascular](#); [DRUG INTERACTIONS](#)). Hypocalcemia, hypokalemia, and hypomagnesemia should be corrected prior to initiating or continuing CABOMETYX administration.

Liver Function

Monitoring of ALT, AST and bilirubin before initiation of, and periodically throughout treatment with CABOMETYX is recommended.

Osteonecrosis

Events of osteonecrosis of the jaw (ONJ) have been observed with CABOMETYX. An oral examination should be performed prior to initiation of CABOMETYX and periodically during therapy. Patients should be advised regarding oral hygiene practice. For invasive dental procedures, CABOMETYX treatment should be held at least 28 days prior to scheduled surgery, if possible. Caution should be used in patients receiving agents associated with ONJ, such as bisphosphonates. Withhold CABOMETYX for development of ONJ until complete resolution.

Thyroid Function

Monitoring for thyroid function before initiation of, and periodically throughout, treatment with CABOMETYX is recommended. Hypothyroidism should be treated according to standard medical practice to maintain euthyroid state.

Neurologic

Reversible Posterior Leukoencephalopathy Syndrome

Reversible Posterior Leukoencephalopathy Syndrome (RPLS), also known as Posterior Reversible Encephalopathy Syndrome (PRES), has been observed with CABOMETYX. This syndrome should be considered in any patient presenting with multiple symptoms, including seizures, headache, visual disturbances, confusion or altered mental function. CABOMETYX treatment should be discontinued in patients with RPLS (see [DOSAGE AND ADMINISTRATION](#)).

Peri-Operative Considerations

Wound Complications

In RCC patients previously treated with VEGF-targeted therapy (XL184-308) wound complications have been observed in 2% of patients treated with CABOMETYX. CABOMETYX treatment should be stopped at least 28 days prior to scheduled surgery, including dental surgery, if possible. The decision to resume CABOMETYX therapy after surgery should be based on clinical judgment of adequate wound healing. CABOMETYX should be discontinued in patients with wound healing complications requiring medical intervention.

Renal

Proteinuria

In RCC patients previously treated with VEGF-targeted therapy (XL184-308), proteinuria had been observed in 12% of patients treated with CABOMETYX. Grade 3 or higher occurred in 2% of CABOMETYX treated patients. In HCC patients treated with CABOMETYX, the rate of proteinuria was 4% (2% Grade \geq 3). Monitor urine protein regularly during CABOMETYX treatment. Discontinue CABOMETYX in patients who develop nephrotic syndrome (see [DOSAGE AND ADMINISTRATION](#)).

Sexual Health

Reproduction

Women of childbearing potential must be advised to avoid pregnancy while on CABOMETYX. Female partners of male patients taking CABOMETYX must also avoid pregnancy. Effective methods of contraception should be used by male and female patients and their partners during therapy, and for at least 4 months after completing therapy. Because oral contraceptives might possibly not be considered as “effective methods of contraception”, they should be used together with another method, such as a barrier method (see [DRUG INTERACTIONS](#)).

Fertility

There are no data on human fertility. Based on non-clinical safety findings, male and female fertility may be compromised by treatment with CABOMETYX. Both men and women should be advised to seek advice and consider fertility preservation before treatment (see [NONCLINICAL TOXICOLOGY](#)).

Skin

Palmar-Plantar Erythrodysesthesia Syndrome

In the pivotal clinical trial in previously treated RCC patients (XL184-308), palmar-plantar erythrodysesthesia syndrome (PPES) had been observed in 42% of patients treated with CABOMETYX. Grade 3 PPES occurred in 8% of CABOMETYX-treated patients. Dose modifications due to PPES occurred in 16% of patients. The rate of PPES in HCC CABOMETYX-treated patients was 46% (17% Grade 3); a dose modification rate was 28%. Withhold CABOMETYX in patients who develop intolerable Grade 2 PPES or Grade 3 PPES until improvement to Grade 1; resume CABOMETYX at a reduced dose.

7.1 Special Populations

7.1.1 Pregnant Women

There are no studies in pregnant women using CABOMETYX. Studies in animals have shown embryo-foetal and teratogenic effects at exposures below those occurring clinically at the recommended dose. The potential risk for humans is unknown. CABOMETYX should not be used during pregnancy unless the clinical condition of the woman requires treatment with CABOMETYX.

Embryo-fetal development studies were performed in rats and rabbits. In rats, cabozantinib caused post-implantation loss, fetal edema, cleft palate/lip, dermal aplasia and kinked or rudimentary tail. In rabbits, cabozantinib produced fetal soft tissue changes (reduced spleen size, small or missing intermediate lung lobe) and increased fetal incidence of total malformations. NOAEL for embryo-fetal toxicity and teratogenic findings were below human clinical exposure levels at intended therapeutic dose (see [DRUG INTERACTIONS](#), [ACTION AND CLINICAL PHARMACOLOGY](#), [Mechanism of Action](#)).

7.1.2 Breast-feeding

It is not known whether cabozantinib and/or its metabolites are excreted in human milk. Because of the potential harm to the infant, mothers should discontinue breast-feeding during treatment with CABOMETYX, and for at least 4 months after completing therapy.

7.1.3 Pediatrics

Pediatrics (<18 years of age): No data are available to Health Canada; therefore, Health Canada has not authorized an indication for pediatric use.

7.1.4 Geriatrics (> 65 years of age)

No specific dose adjustment for the use of CABOMETYX in older people (≥ 65 years) is recommended.

8 ADVERSE REACTIONS

8.1 Adverse Reaction Overview

The most common adverse reactions (in $\geq 25\%$ of patients) included: diarrhea, fatigue, hypertension, decreased appetite, palmar-plantar erythrodysesthesia syndrome (PPES), nausea, weight decreased, AST increased, ALT increased, dysgeusia, platelet count decreased, stomatitis, anemia, vomiting, dyspepsia and constipation.

Within 30 days of the last dose administration, 4 treatment-naïve RCC patients died (gastrointestinal perforation n=2; acute renal failure n=1 and clinical deterioration n=1).

Serious adverse events (SAEs), other than renal cell carcinoma reported in $\geq 1\%$ of RCC patients were hypertension, diarrhea, embolism, PPES, dehydration, decreased weight, decreased appetite, hypophosphatemia, hypotension, lung infection, nausea, acute renal failure, skin ulcer, stomatitis, syncope, pulmonary embolism, ALT increased, hyponatremia, vomiting, fatigue and hypomagnesemia. SAEs reported in $\geq 1\%$ of HCC patients were hepatic encephalopathy, asthenia, abdominal pain, fatigue, PPES, diarrhea, hyponatremia and thrombocytopenia.

Grade 3-4 adverse events (AEs) and laboratory abnormalities reported in $\geq 5\%$ of RCC patients were hypertension, diarrhea, PPES, fatigue, hyponatremia, hypophosphatemia, embolism, ALT increased, anemia, decreased appetite, hypotension, pain and stomatitis. Grade 3-4 AEs and laboratory abnormalities which occurred in $\geq 5\%$ of HCC patients were PPES, hypertension, AST increased, fatigue, diarrhea, asthenia and decreased appetite.

Adverse reactions led to permanent discontinuation of CABOMETYX treatment in 10% of RCC patients previously treated with VEGF-targeted therapy. The most frequent adverse reactions leading to permanent discontinuation were decreased appetite (2%) and fatigue (1%).

Adverse reactions requiring dose reductions occurred in 60% of RCC patients previously treated with VEGF-targeted therapy. Two dose reductions were required in 19% of patients. Twenty percent CABOMETYX (20%) of patients received 20 mg CABOMETYX as their lowest dose. The median time to first dose reduction was 55 days, and to first dose interruption was 38 days. The most frequent adverse reactions leading to dose reduction were: diarrhea (16%), PPES (11%), fatigue (10%), and hypertension (8%). In the pivotal clinical trial in previously treated HCC patients, dose reductions and dose interruptions occurred in 62% and 84%, respectively, of CABOMETYX-treated patients. Two dose reductions were required in 33% of patients. The median time to first dose reduction was 38 days, and to first dose interruption was 28 days. Closer monitoring is advised in patients with mild or moderate hepatic impairment.

Adverse reactions led to CABOMETYX treatment interruptions in 70% of RCC patients previously treated with VEGF-targeted therapy. The most frequent adverse reactions leading to treatment interruptions were: diarrhea (22%), PPES (14%) and fatigue (12%). In the treatment-naïve RCC study (A031203), dose modifications (reduction or interruption) were reported for 81% of subjects in the CABOMETYX arm and 76% of subjects in the sunitinib arm. There was a longer duration of exposure in the CABOMETYX arm compared with the sunitinib arm (median: 6.5 months vs 3.1 months). Dose reductions (46% CABOMETYX vs 35% sunitinib) and dose interruptions (73% vs 71%) were frequent with both agents, indicating that dose modifications were effectively used to manage side effects. Twenty-one percent (21%) of subjects in the CABOMETYX arm and 22% in the sunitinib arm discontinued study treatment due to an AE.

8.2 Clinical Trial Adverse Reactions

Because clinical trials are conducted under very specific conditions, the adverse reaction rates observed in the clinical trials may not reflect the rates observed in practice and should not be compared to the rates in the clinical trials of another drug. Adverse reaction information from clinical trials is useful for identifying drug-related adverse events and for approximating rates.

XL184-308

The safety of CABOMETYX was evaluated in a randomized (1:1), open-label, multicenter, active comparator-controlled phase 3 study (XL184-308) in which 331 patients with advanced renal cell carcinoma received 60 mg CABOMETYX and 322 patients received 10 mg everolimus administered daily until disease progression or unacceptable toxicity. Patients on both arms who had disease progression could continue treatment at the discretion of the investigator. The median duration of treatment was 7.6 months (range 0.3-20.5) for patients receiving CABOMETYX and 4.4 months (range 0.21 – 18.9) for patients receiving everolimus.

Interruption of CABOMETYX treatment was allowed at the discretion of the investigator. If treatment was interrupted due to adverse reactions for more than 6 weeks, CABOMETYX was discontinued.

Table 2: Adverse Reactions Occurring in ≥ 10% of RCC Patients Previously Treated with VEGF-Targeted Therapy in Study XL184-308

	CABOMETYX n = 331 ¹ (%)		Everolimus n = 332 (%)	
	All Grades ²	Grade 3-4	All Grades ²	Grade 3-4
Blood and Lymphatic Disorders				
Anemia	17	5	38	16
Endocrine Disorders				
Hypothyroidism	21	0	<1	<1

	CABOMETYX n = 331 ¹ (%)		Everolimus n = 332 (%)	
	All Grades ²	Grade 3-4	All Grades ²	Grade 3-4
Gastrointestinal Disorders				
Diarrhea	74	11	28	2
Nausea	50	4	28	<1
Vomiting	32	2	14	<1
Constipation	25	<1	19	<1
Abdominal pain ³	23	4	13	2
Stomatitis	22	2	24	2
Dyspepsia	12	<1	5	0
General Disorders and Administration Site Conditions				
Fatigue	56	9	47	7
Asthenia	19	4	16	2
Mucosal inflammation	19	<1	23	3
Investigations				
Weight decreased	31	2	12	0
Metabolism and Nutrition Disorders				
Decreased Appetite	46	3	34	<1
Musculoskeletal and Connective Tissue				
Pain in extremity	14	1	8	<1
Muscle spasms	13	0	5	0
Arthralgia	11	<1	14	1
Nervous System Disorders				
Dysgeusia	24	0	9	0
Headache	11	<1	12	<1
Dizziness	11	0	7	0
Renal and Urinary Disorders				
Proteinuria	12	2	9	<1
Respiratory, Thoracic, and Mediastinal				
Dysphonia	20	<1	4	0
Dyspnea	19	3	29	4
Cough	18	<1	33	<1
Skin and Subcutaneous Tissue Disorders				
Palmar-plantar erythrodysesthesia syndrome	42	8	6	<1
Rash ⁴	23	<1	43	<1
Dry Skin	11	0	10	0
Vascular Disorders				
Hypertension ⁵	39	16	8	3

	CABOMETYX n = 331 ¹ (%)		Everolimus n = 332 (%)	
	All Grades ²	Grade 3-4	All Grades ²	Grade 3-4
1 One subject randomized to everolimus received cabozantinib.				
2 National Cancer Institute Common Terminology Criteria for Adverse Events Version 4.0				
3 Includes PT terms abdominal pain, abdominal pain upper, and abdominal pain lower				
4 Includes PT terms rash, rash erythematous, rash follicular, rash macular, rash papular, rash pustular, rash vesicular, genital rash, intermittent leg rash, rash on scrotum and penis, rash maculo-papular, rash pruritic, contact dermatitis, dermatitis acneiform				
5 Includes PT terms hypertension, blood pressure increased, hypertensive crisis, blood pressure fluctuation				

Grade 3 or 4 AEs occurring in CABOMETYX-treated patients at a rate higher than what was seen in patients receiving everolimus (and not included in Table 2 or 5) were: hypokalemia, lipase increased, pleural effusion, pulmonary embolism, hypocalcemia, blood bilirubin increased and syncope.

A031203

The safety of CABOMETYX was evaluated in a randomized (1:1), open-label, multicenter, active comparator-controlled phase 2 study (A031203) in which 79 patients with advanced renal cell carcinoma received 60 mg CABOMETYX and 78 patients received 50 mg sunitinib taken once daily (4 weeks on treatment followed by 2 weeks off), until disease progression or unacceptable toxicity. The median duration of treatment was 6.5 months (range 0.2 – 28.7) for patients receiving CABOMETYX and 3.1 months (range 0.2 – 25.5) for patients receiving sunitinib.

Interruption of CABOMETYX treatment was allowed at the discretion of the investigator. If treatment was interrupted due to adverse reactions for more than 6 weeks, CABOMETYX was discontinued.

Table 3: Adverse Reactions Occurring in ≥ 10% of Treatment-Naïve RCC Patients in Study A031203

	CABOMETYX n = 78 (%)		Sunitinib n = 72 (%)	
	All Grades	Grade 3-4	All Grades	Grade 3-4
Blood and Lymphatic Disorders				
Anemia	33	1	46	3
Endocrine Disorders				
Hypothyroidism	23	0	6	0

	CABOMETYX n = 78 (%)		Sunitinib n = 72 (%)	
	All Grades	Grade 3-4	All Grades	Grade 3-4
Gastrointestinal Disorders				
Diarrhea	73	10	54	11
Stomatitis	37	5	29	6
Nausea	32	3	39	4
Dyspepsia	27	0	17	0
Vomiting	23	1	22	3
Dry Mouth	19	0	13	0
Constipation	18	1	15	0
Abdominal pain	13	0	11	4
Oral pain	10	0	8	0
General Disorders and Administration Site Conditions				
Fatigue	64	6	68	17
Pain	13	5	6	0
Investigations				
AST increased	60	3	31	3
ALT increased	55	5	28	0
Platelet count decreased	38	1	61	11
Weight decreased	32	4	17	0
Blood creatinine increased	24	3	21	3
Hypophosphatemia	23	9	17	7
Hypomagnesemia	22	3	11	0
Hyperglycemia	21	0	15	6
Hypoalbuminemia	19	0	17	0
Hypocalcemia	18	3	15	0
Hypokalemia	15	1	7	0
Neutrophil count decreased	15	0	35	4
Hyponatremia	14	9	22	8
Blood bilirubin increased	14	0	7	1
Lymphocyte count decreased	13	1	18	6
Blood ALP increased	13	0	13	1
White blood cell count decreased	12	0	35	3
Metabolism and Nutrition Disorders				
Decreased Appetite	47	5	32	1
Dehydration	12	4	10	1
Edema Peripheral	8	0	14	0
Musculoskeletal and Connective Tissue				
Back pain	10	4	6	0
Pain in extremity	10	3	10	0
Arthralgia	10	1	7	0
Muscular Weakness	4	0	17	1

	CABOMETYX n = 78 (%)		Sunitinib n = 72 (%)	
	All Grades	Grade 3-4	All Grades	Grade 3-4
Nervous System Disorders				
Dysgeusia	41	0	29	0
Dizziness	22	1	22	0
Headache	12	1	17	1
Insomnia	10	0	8	0
Peripheral Sensory Neuropathy	10	1	6	0
Renal and Urinary Disorders				
Proteinuria	6	3	14	1
Respiratory, Thoracic, and Mediastinal				
Dysphonia	22	1	1	0
Dyspnea	17	1	19	6
Cough	12	0	7	0
Skin and Subcutaneous Tissue Disorders				
Palmar-plantar erythrodysesthesia syndrome	42	8	33	4
Dry Skin	19	0	8	0
Alopecia	18	0	3	0
Rash Maculo-Papular	15	0	13	3
Dermatitis Acneiform	15	0	3	0
Vascular Disorders				
Hypertension	67	28	44	21
Embolism	12	8	1	0
Hypotension	10	5	4	1
Epistaxis	10	0	4	0

XL184-309

The safety of CABOMETYX was evaluated in a randomized (2:1), double-blind, controlled study vs. placebo in 704 subjects with hepatocellular carcinoma who had received prior sorafenib therapy. The randomized subjects received CABOMETYX 60 mg once daily (n=467) or matching placebo (n=237). The median duration of treatment was 3.8 months (range 0.1-37.3) for patients receiving CABOMETYX and 2.0 months (range 0.0-27.2) for patients receiving placebo. Dose modification rates due to AEs were 88% vs 39% with CABOMETYX vs placebo. The median average daily dose for CABOMETYX was 36 mg.

There was a higher rate in the CABOMETYX group of treatment discontinuation due to AEs (CABOMETYX 21% vs placebo 5%), including AEs related to study treatment (16% vs 3%). Overall rate of Grade \geq 3 AEs was higher with CABOMETYX (68% vs 36%) as was the rate of SAEs (50% vs 37%). Grade 5 AEs that were considered to be treatment-related occurred in 6 patients receiving CABOMETYX (esophagobronchial fistula, hepatic failure, hepatorenal syndrome, portal-vein thrombosis, upper gastrointestinal hemorrhage, pulmonary embolism) and in 1 patient in the placebo group (hepatic failure).

Table 4: Adverse Reactions Occurring in \geq 10% of HCC Patients in Study XL184-309

	CABOMETYX n = 467 (%)		Placebo n = 237 (%)	
	All Grades	Grade 3-4	All Grades	Grade 3-4
Gastrointestinal Disorders				
Diarrhea	54	10	19	2
Nausea	31	2	18	2
Vomiting	26	0	12	3
Constipation	19	0	19	0
Abdominal Pain	18	2	25	4
Stomatitis	13	2	2	0
Abdominal Pain Upper	13	1	13	0
Dyspepsia	10	0	3	0
General Disorders and Administration Site Conditions				
Fatigue	45	10	30	4
Asthenia	22	7	8	2
Mucosal inflammation	14	2	2	0
Pyrexia	14	0	10	0
Hepatobiliary Disorders				
Ascites	12	4	13	5
Investigations				
AST Increased	22	12	11	7
ALT Increased	17	5	6	2
Weight decreased	17	1	6	0
Hypoalbuminemia	12	0	5	0
Thrombocytopenia	11	3	0	0
Metabolism and Nutrition Disorders				
Decreased Appetite	48	6	18	0
Musculoskeletal and Connective Tissue				
Back pain	10	1	10	0
Nervous System Disorders				
Edema Peripheral	13	1	14	1
Dysgeusia	12	0	2	0
Headache	11	0	7	0
Insomnia	10	0	7	0
Dizziness	10	0	6	0
Respiratory, Thoracic, and Mediastinal				
Dysphonia	19	1	2	0
Cough	13	0	11	0
Dyspnea	12	3	10	0
Skin and Subcutaneous Tissue Disorders				
Palmar-plantar erythrodysesthesia syndrome	46	17	5	0
Rash	12	0	6	0
Vascular Disorders				
Hypertension	29	16	6	2

8.3 Less Common Clinical Trial Adverse Reactions (2%)

Gastrointestinal: pancreatitis

Hepatobiliary Disorders: hepatitis cholestatic

Musculoskeletal Disorders: osteonecrosis of the jaw

Nervous System Disorders: convulsion

Skin and Subcutaneous Tissue Disorders: wound complications

8.4 Abnormal Laboratory Findings: Hematologic, Clinical Chemistry and Other Quantitative Data

Table 5: Laboratory Abnormalities Occurring in \geq 25% Patients Who Received CABOMETYX in Study XL184-308

Test	CABOMETYX n = 331 (%)		Everolimus n = 332 (%)	
	All Grades	Grade 3-4	All Grades	Grade 3-4
Chemistry				
AST increased	74	3	40	<1
ALT increased	68	3	32	<1
Creatinine increased	58	<1	71	0
Triglycerides increased	53	4	73	13
Hypophosphatemia	48	8	36	5
Hyperglycemia	37	2	59	8
Hypoalbuminemia	36	2	28	<1
ALP increased	35	2	29	1
Hypomagnesemia	31	7	4	<1
Hyponatremia	30	8	26	6
GGT increased	27	5	43	9
Hematology				
White blood cells decreased	35	<1	31	<1
Absolute neutrophil count decreased	31	2	17	<1
Hemoglobin decreased	31	4	71	17
Lymphocytes decreased	25	7	39	12
Platelets decreased	25	<1	27	<1
ALP, alkaline phosphatase; ALT, alanine aminotransferase; AST, aspartate aminotransferase; GGT, gamma glutamyl transferase. National Cancer Institute Common Terminology Criteria for Adverse Events, Version 4.0				

In HCC patients, the most frequent (\geq 25%) treatment-emergent laboratory abnormalities (all grades) reported in the CABOMETYX arm were: LDH increased, ALT increased, AST increased, albumin decreased, glucose increased, ALP increased, sodium decreased, total bilirubin increased, GGT increased, phosphate decreased, platelets decreased, white blood cell count decreased, absolute neutrophil count decreased, lymphocytes decreased, hemoglobin decreased and hemoglobin increased.

8.5 Post-Market Adverse Drug Reactions

Vascular disorders: Artery dissection and artery aneurysm (including rupture) have been reported in association with VEGFR TKIs.

9 DRUG INTERACTIONS

9.1 Overview

CABOMETYX (cabozantinib) is a substrate of CYP3A4, and also a moderate inhibitor of the multidrug efflux pump P-glycoprotein (P-gp). Therefore, absorption and subsequent elimination of cabozantinib may be influenced by products that affect CYP3A4 and/or P-gp.

In vitro, cabozantinib is a competitive inhibitor of CYP3A4 and a mixed inhibitor of CYP2D6.

9.2 Drug-Drug Interactions

The drugs listed in this table are based on either drug interaction case reports or studies, or potential interactions due to the expected magnitude and seriousness of the interaction (i.e., those identified as contraindicated).

Table 6: Established or Potential Drug-Drug Interactions

CABOMETYX	Source of Evidence	Effect	Clinical comment
CYP3A4 inhibitors	CT	Administration of the strong CYP3A4 inhibitor ketoconazole (400 mg daily for 27 days) to healthy volunteers decreased cabozantinib clearance (by 29%) and increased single-dose plasma cabozantinib exposure (AUC) by 38%.	Co-administration of strong CYP3A4 inhibitors (e.g., ritonavir, itraconazole, erythromycin, clarithromycin, grapefruit juice) with cabozantinib should be approached with caution. Increased CABOMETYX exposure may increase the risk of exposure-related toxicity and the selection of an alternative agent should be considered.
CYP3A4 inducers	CT	Administration of the strong CYP3A4 inducer rifampicin (600 mg daily for 31 days) to healthy volunteers increased cabozantinib clearance (4.3-fold) and decreased single-dose plasma cabozantinib exposure (AUC) by 77%.	Chronic co-administration of strong CYP3A4 inducers (e.g., phenytoin, carbamazepine, rifampicin, phenobarbital or herbal preparations containing St. John's Wort [<i>Hypericum perforatum</i>]) with cabozantinib should therefore be avoided and alternative agents should be considered as the efficacy of CABOMETYX may be substantially reduced.

CABOMETYX	Source of Evidence	Effect	Clinical comment
Gastric pH modifying agents	CT	Co-administration of proton pump inhibitor (PPI) esomeprazole (40 mg daily for 6 days) with a single dose of 100 mg cabozantinib to healthy volunteers resulted in no clinically-significant effect on plasma cabozantinib exposure (AUC).	No dose adjustment is indicated when gastric pH modifying agents (i.e., PPIs, H2 receptor antagonists, and antacids) are co-administered with cabozantinib.
MRP2 inhibitors	CT	<i>In vitro</i> data demonstrate that cabozantinib is a substrate of MRP2.	Administration of MRP2 inhibitors may result in increases in cabozantinib plasma concentrations.
Bile salt-sequestering agents	T	Bile salt-sequestering agents such as cholestyramine and cholestigel may interact with cabozantinib and may impact absorption (or reabsorption) resulting in potentially decreased exposure	The clinical significance of these potential interactions is unknown.
Contraceptive steroids	T	The effect of cabozantinib on the pharmacokinetics of contraceptive steroids has not been investigated.	As unchanged contraceptive effect may not be guaranteed, an additional contraceptive method, such as a barrier method, is recommended.
Warfarin	T	Because of high plasma protein binding levels of cabozantinib, a plasma protein displacement interaction with warfarin may be possible.	INR values should be monitored.
P-glycoprotein substrates (P-gp)	CT	Cabozantinib was an inhibitor (IC50 = 7.0 μM), but not a substrate, of P-gp transport activities in a bi-directional assay system using MDCK-MDR1 cells.	Cabozantinib may have the potential to increase plasma concentrations of co-administered substrates of P-gp.

Legend: C = Case Study; CT = Clinical Trial; T = Theoretical

9.3 QTc Interval-Prolonging Drugs

The concomitant use of CABOMETYX with QTc interval-prolonging drugs should be avoided to the extent possible (see [WARNINGS AND PRECAUTIONS, Cardiovascular, Monitoring and Laboratory Tests](#) and [ACTION AND CLINICAL PHARMACOLOGY, Cardiac Electrophysiology](#)). Drugs that have been associated with QT interval prolongation and/or torsade de pointes include, but are not limited to, the examples in the following list. Chemical/pharmacological classes are listed if some, although not necessarily all, class members have been implicated in QT/QTc interval prolongation and/or torsade de pointes: Class IA antiarrhythmics; Class III antiarrhythmics; Class 1C antiarrhythmics; antipsychotics; antidepressants; opioids; macrolide antibiotics and analogues; quinolone antibiotics; pentamidine; antimalarials; azole antifungals;

domperidone; 5-hydroxytryptamine (5-HT)₃ receptor antagonists; kinase inhibitors; arsenic trioxide; histone deacetylase inhibitors; beta-2 adrenoceptor agonists.

Drugs that Decrease Heart Rate and/or Prolong the PR Interval

CABOMETYX results in a decrease in heart rate and an increase in the PR interval (see [WARNINGS AND PRECAUTIONS, Cardiovascular, Monitoring and Laboratory Tests](#) and [ACTION AND CLINICAL PHARMACOLOGY, Cardiac Electrophysiology](#)). Caution should be observed if CABOMETYX is used concomitantly with other drugs that lower heart rate and/or prolong the PR interval, including, but not limited to, antiarrhythmics, beta adrenoceptor antagonists, non-dihydropyridine calcium channel blockers, digitalis glycosides, cholinesterase inhibitors, sphingosine-1 phosphate receptor modulators, HIV protease inhibitors, alpha₂-adrenoceptor agonists, and I_f blockers.

Drugs that Affect Electrolytes

Caution should be observed if CABOMETYX is administered with drugs that can deplete electrolyte levels. Drugs that can reduce electrolyte levels include, but are not limited to, the following: loop, thiazide, and related diuretics; laxatives and enemas; amphotericin B; high-dose corticosteroids and proton pump inhibitors.

The above lists of potentially interacting drugs are not comprehensive. Current information sources should be consulted for newly approved drugs that prolong the QTc interval, decrease heart rate and/or prolong the PR interval, or decrease electrolytes, as well as for older drugs for which these effects have recently been established.

10 ACTION AND CLINICAL PHARMACOLOGY

10.1 Mechanism of Action

Cabozantinib is a small molecule that inhibits multiple receptor tyrosine kinases (RTKs) implicated in tumour growth and angiogenesis, pathologic bone remodeling, drug resistance, and metastatic progression of cancer. Cabozantinib has a distinct mechanism of action with primary inhibition targets of MET (hepatocyte growth factor receptor protein), VEGF (vascular endothelial growth factor) receptors and GAS6 receptor (AXL). VEGF, MET and AXL receptors are involved in tumour progression and drug resistance in RCC. In addition, cabozantinib inhibits other tyrosine kinases including RET, ROS1, TYRO3, MER, the stem cell factor receptor (KIT), TRKB, Fms-like tyrosine kinase-3 (FLT3), and TIE-2.

10.2 Pharmacodynamics

Cabozantinib exhibited dose-related tumour growth inhibition, tumour regression, and/or inhibited metastasis in a broad range of preclinical tumour models.

Cardiac Electrophysiology

In a placebo-controlled clinical trial in patients with medullary thyroid cancer receiving the cabozantinib 138 mg once-daily capsule (N=214) or placebo (N=109), serial ECGs were collected on Day 1 and during steady-state treatment on Day 29. During steady-state cabozantinib treatment, prolongation of the QTcF and PR intervals and a reduction in heart rate were observed. An increase from baseline in corrected QT interval by Fridericia (QTcF) of 10 – 15 ms was observed on Day 29 (but not on Day 1). The maximum differences from placebo in the mean change from baseline on Day 29 were 10.9 ms (90% CI 8.0, 13.9) for the QTcF interval, 6.2 ms (90% CI 3.4, 9.0) for the PR interval, and -6.7 bpm (90% CI -8.6, -4.7) for heart

rate. No cabozantinib-treated subjects in this study were observed to have QTcF >500 ms, nor did any cabozantinib-treated subjects in the RCC study (at a dose of 60 mg).

The mean C_{max} (1510 ng/mL) of cabozantinib achieved on Day 29 in this study in patients with medullary thyroid cancer receiving once daily dosing with the 138 mg capsule was comparable to the mean steady-state C_{max} (1230 ng/mL) in patients with renal cell carcinoma receiving once-daily dosing with the 60 mg tablet.

10.3 Pharmacokinetics

Table 7: Summary of Pharmacokinetic parameters

Parameters	Mean*	90% Confidence Interval (CI)
Apparent clearance CL/F (L/h)	2.23	2.13 – 2.34
Apparent volume of distribution (central compartment) Vc/F (L)	81.45	68.5 – 96.8
Apparent terminal half-life (h)**	99	

*: mean values based on population PK analysis

** : parameter derived from CL/F and Vc/F, therefore no 90% CI available

Absorption: Following oral administration of cabozantinib, peak cabozantinib plasma concentrations are reached at 3 to 4 hours post-dose. Plasma-concentration time profiles show a second absorption peak approximately 24 hours after administration, which suggests that cabozantinib may undergo enterohepatic recirculation.

Repeat daily dosing of cabozantinib at 140 mg for 19 days resulted in an approximately a 4- to 5-fold mean cabozantinib accumulation (based on AUC) compared to a single dose administration; steady state is achieved by approximately Day 15.

A high-fat meal increased C_{max} and AUC values (by 41% and 57%, respectively) relative to fasted conditions in healthy volunteers administered a single 140 mg oral cabozantinib dose. There is no information on the precise food-effect when taken 1 hour after administration of cabozantinib.

Distribution: Cabozantinib is highly protein bound *in vitro* in human plasma ($\geq 99.7\%$). Based on the population pharmacokinetic (PK) model, the volume of distribution (V_z) is approximately 319 L (SE: $\pm 2.7\%$). Protein binding was not altered in subjects with mild or moderately impaired renal or hepatic function.

Metabolism: Cabozantinib was metabolized *in vivo*. Four metabolites were present in plasma at exposures (AUC) greater than 10% of parent: XL184-N-oxide, XL184 amide cleavage product, XL184 monohydroxy sulfate, and 6-desmethyl amide cleavage product sulfate. Two non-conjugated metabolites (XL184-N-oxide and XL184 amide cleavage product), which possess <1% of the on-target kinase inhibition potency of parent cabozantinib, each represent <10% of total drug-related plasma exposure.

Cabozantinib is a substrate for CYP3A4 metabolism *in vitro*, as a neutralizing antibody to CYP3A4 inhibited formation of metabolite XL184 N-oxide by >80% in a NADPH-catalyzed human liver microsomal (HLM) incubation; in contrast, neutralizing antibodies to CYP1A2, CYP2A6,

CYP2B6, CYP2C8, CYP2C19, CYP2D6 and CYP2E1 had no effect on cabozantinib metabolite formation. A neutralizing antibody to CYP2C9 showed a minimal effect on cabozantinib metabolite formation (i.e. a <20% reduction).

Elimination: In a population PK analysis of cabozantinib using data collected from 318 patients with RCC and 63 normal healthy volunteers following oral administration of doses of 60 mg, 40 mg, and 20 mg, the plasma terminal half-life of cabozantinib is approximately 99 hours. Mean clearance (CL/F) at steady-state was estimated to be 2.2 L/hr. Within a 48-day collection period after a single dose of ¹⁴C-cabozantinib in healthy volunteers, approximately 81% of the total administered radioactivity was recovered with 54% in faeces and 27% in urine.

Special Populations and Conditions

The following patient characteristics did not result in a clinically relevant difference in the pharmacokinetics of cabozantinib: age (32-86 years), sex, race (Whites and non-Whites), or mild to moderate renal impairment (eGFR greater than or equal to 30 mL/min/1.73 m² as estimated by MDRD (modification of diet in renal disease equation)). The pharmacokinetics of cabozantinib is unknown in patients with worse than moderate renal impairment (eGFR less than 29 mL/min/1.73m²) as estimated by MDRD equation or renal impairment requiring dialysis.

Pediatrics: The pharmacokinetics of cabozantinib has not been studied in the pediatric population (see [WARNINGS AND PRECAUTIONS, Special Populations](#)).

Ethnic origin: A population PK analysis did not identify clinically relevant differences in PK of cabozantinib based on race.

Hepatic Insufficiency: Cabozantinib exposure (AUC_{0-inf}) increased by 81% and 63% in subjects with mild and moderate hepatic impairment, respectively (90% CI for AUC_{0-inf}: 121.44% to 270.34% for mild and 107.37% to 246.67% for moderate). Patients with severe hepatic impairment have not been studied.

Renal Insufficiency: Ratios of geometric LS mean for plasma cabozantinib, C_{max} and AUC_{0-inf} were 19% and 30% higher, for subjects with mild renal impairment (90% CI for C_{max} 91.60% to 155.51%; AUC_{0-inf} 98.79% to 171.26%) and 2% and 6-7% higher (90% CI for C_{max} 78.64% to 133.52%; AUC_{0-inf} 79.61% to 140.11%), for subjects with moderate renal impairment compared to subjects with normal renal function. Patients with severe renal impairment have not been studied.

11 STORAGE, STABILITY AND DISPOSAL

Store CABOMETYX (cabozantinib) at room temperature (15°C to 25°C).

Keep out of sight and reach of children.

PART II: SCIENTIFIC INFORMATION

12 PHARMACEUTICAL INFORMATION

Drug Substance

Proper/Common name: cabozantinib (S)-malate

Chemical name: N-(4-(6,7-dimethoxyquinolin-4-yloxy)phenyl)-N'-(4-fluorophenyl)cyclopropane-1,1-dicarboxamide, (2S)-hydroxybutanedioate.

Molecular formula and molecular mass: $C_{28}H_{24}FN_3O_5 \cdot C_4H_6O_5$
635.6 Daltons as malate salt

Structural formula:

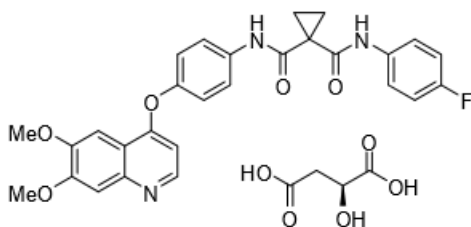

Physicochemical properties: Cabozantinib (S)-malate was found to exist in two neat, closely related solid forms (N-1 and N-2) that have similar properties.

Physical Description: white to off-white solid

Solubility: 0.03 mg/mL in water
0.3 mg/mL in methyl ethyl ketone

pH: ~100mcg/mL at pH 3; practically insoluble above pH 4

pKa: 6.32

Partition coefficient: log D50 = 3.88; log P = 5.15

Melting Point: N-1 ~186.50C; N-2 ~185.40C; Amorphous Tg ~900C>

13 CLINICAL TRIALS

13.1 Trial Design and Study Demographics

Table 8: Summary of patient demographics for clinical trials in RCC and HCC

Study #	Trial design	Dosage, route of administration	Study subjects (n)	Mean age (Range)	Sex
XL184-308 (METEOR)	Open label, active-controlled, randomized 2-arm phase 3 study	CABOMETYX (60 mg) daily, oral	N=330	62.5 (32, 86)	77%M
		everolimus (10 mg) daily, oral	N=328	62.0 (31, 84)	73%M
A031203 (CABOSUN)	Open label, active-controlled, randomized 2-arm phase 2 study	CABOMETYX (60 mg) daily, oral	N=79	62.0 (40, 82)	84%M
		sunitinib (50 mg) daily, oral	N=78	63.6 (31, 87)	57%M
XL184-309 (CELESTIAL)	Double-blind, placebo-controlled, randomized 2-arm phase 3 study	CABOMETYX (60 mg) daily, oral	N=467	64.0 (22, 86)	81%M
		Placebo daily, oral	N=237	64.0 (24, 86)	85%M

XL184-308

The safety and efficacy of CABOMETYX (cabozantinib) were evaluated in a randomized, open-label, multicenter Phase 3 study (METEOR). Patients (N=658) with advanced Renal Cell Carcinoma (RCC) with a clear cell component who had previously received at least 1 prior VEGF receptor tyrosine kinase inhibitor (VEGFR TKI) were randomized (1:1) to receive CABOMETYX (N=330) or everolimus (N=328). Patients could have received other prior therapies, including cytokines, and antibodies targeting VEGF, the programmed death 1 (PD-1) receptor, or its ligands. Patients with treated brain metastases were allowed. Progression-free survival (PFS) was assessed by a blinded independent radiology review committee, and the primary analysis was conducted among the first 375 subjects randomized. Secondary efficacy endpoints were objective response rate (ORR) and overall survival (OS). Tumor assessments were conducted every 8 weeks for the first 12 months, then every 12 weeks thereafter.

The baseline demographic and disease characteristics were similar between the CABOMETYX and everolimus arms. The majority of the patients were male (75%), with a median age of 62 years. Seventy-one percent (71%) received only one prior VEGFR TKI; 41% of patients received sunitinib as their only prior VEGFR TKI. According to the Memorial Sloan Kettering Cancer Center criteria for prognostic risk category, 46% were favorable (0 risk factors), 42% were intermediate (1 risk factor), and 13% were poor (2 or 3 risk factors). Fifty-four percent (54%) of patients had 3 or more organs with metastatic disease, including lung (63%), lymph nodes (62%), liver (29%), and bone (22%). The median duration of treatment was 7.6 months (range 0.3 – 20.5) for patients receiving CABOMETYX and 4.4 months (range 0.21 – 18.9) for patients receiving everolimus.

The main efficacy outcomes measure was progression-free survival (PFS) assessed by blinded independent radiology review committee among the first 375 subjects randomized. Other efficacy

endpoints were objective response rate (ORR) and overall survival (OS) in the Intent-to-Treat (ITT) population. Tumor assessments were conducted every 8 weeks for the first 12 months, then every 12 weeks thereafter. Patients received treatment until disease progression or experiencing unacceptable toxicity.

Statistically significant improvement in PFS was demonstrated for CABOMETYX compared to everolimus (Figure 1 and Table 9). A planned interim analysis of OS was conducted at the time of the PFS analysis and did not reach the interim boundary for statistical significance (HR=0.68 [0.51, 0.90], p=0.006). In a subsequent unplanned interim analysis of OS, a statistically significant improvement was demonstrated for patients randomized to CABOMETYX as compared with everolimus (median of 21.4 months vs. 16.5 months; HR=0.66 [95% CI: 0.53, 0.83], p=0.0003; Figure 2). The follow-up supplemental analysis demonstrated a statistically significant difference in OS for patients randomized to CABOMETYX as compared with everolimus; (median 21.4 months vs. 17.1 months; HR= 0.70 (95% CI: 0.58, 0.85; p-value = 0.0002; Table 10).

Exploratory analyses of PFS and OS in the ITT population have also shown consistent results in favour of CABOMETYX compared to everolimus across different subgroups according to age (<65 vs. ≥65, sex, MSKCC risk group (favourable, intermediate, poor), ECOG status (0 vs. 1), time from diagnosis to randomisation (<1 year vs. ≥1 year), tumour MET status (high vs. low vs. unknown), bone metastases (absence vs. presence), visceral metastases (absence vs. presence), visceral and bone metastases (absence vs. presence), number of prior VEGFR-TKIs (1 vs. ≥2), duration of first VEGFR-TKI (≤6 months vs. >6 months).

Figure 1: Progression-free survival (first 375 randomized)

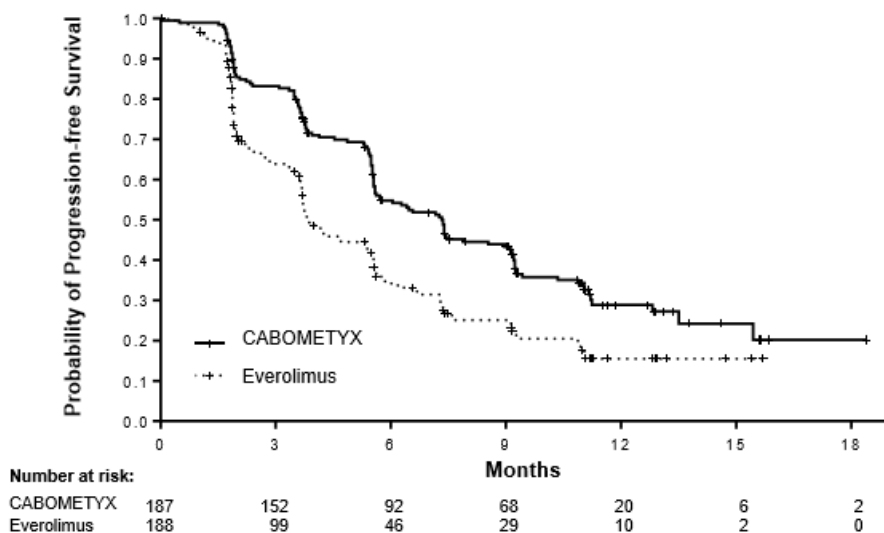

Table 9: Progression-Free Survival (First 375 randomized)

Endpoint	Primary PFS analysis Population	
	CABOMETYX	Everolimus
	N = 187	N = 188
Median PFS (95% CI), months	7.4 (5.6, 9.1)	3.8 (3.7, 5.4)
HR (95% CI), p-value ¹	0.58 (0.45, 0.74), p<0.0001	

¹stratified log-rank test with prior VEGFR-targeting TKI therapy (1 vs 2 or more) and MSKCC prognostic criteria for previously treated patients with RCC (0 vs 1 vs 2 or 3) as stratification factors (per IVRS data)

The PFS analysis was repeated in the ITT population (658 subjects), and results were similar to those obtained for the primary PFS analysis population.

Figure 2: Kaplan-Meier curve of overall survival

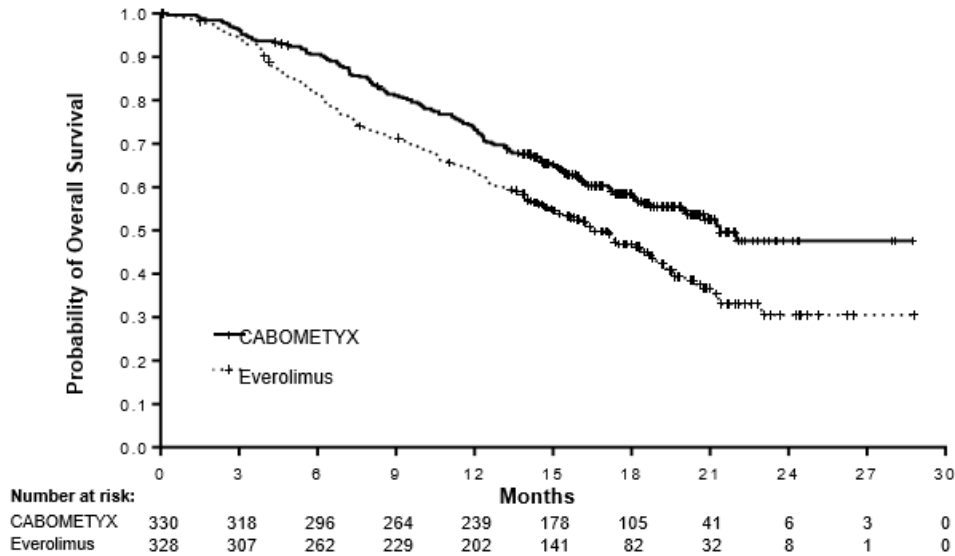

Table 10: Final Overall Survival Rate (ITT)

Endpoint	CABOMETYX	Everolimus
Number (%) of Subjects	330	328
Censored	132 (40)	96 (29)
Death	198 (60)	232 (71)
Duration of overall survival (months)		
Median (95% CI)	21.4 (18.6, 23.5)	17.1 (14.9, 18.9)
25th percentile, 75th percentile	11.5, NE	7.5, 29.5
Range	0.26, 37.8+	0.07+, 35.5+
p-value (stratified log-rank test) ^a	0.0002	
Hazard ratio (95% CI; stratified) ^b	0.70 (0.58, 0.85)	
p-value (unstratified log-rank test)	0.0006	
Hazard ratio (95% CI; unstratified)	0.72 (0.59, 0.87)	

+ indicates a censored observation; CI, confidence interval; ITT, intent-to-treat; IxRS, interactive record system; NE, not estimable; TKI, tyrosine kinase inhibitor; VEGFR, vascular endothelial growth factor receptor.

^a Stratification factors (based on IxRS) were prior VEGFR-targeting TKI therapy: 1 vs 2 or more, and Memorial Sloan-Kettering Cancer Center prognostic criteria (0 vs 1 vs 2 or 3).

^b Estimated using the Cox proportional hazard model adjusted for stratification factors. A hazard ratio <1 indicates overall survival in favor of cabozantinib.

Table 11: Summary of ORR Findings per Independent Radiology Committee Review (IRC) and Investigator Review

Endpoint	Primary Analysis ORR Intent-to-Treat Population (IRC)		ORR per Investigator Review Intent-To-Treat Population	
	CABOMETYX	Everolimus	CABOMETYX	Everolimus
	N = 330	N = 328	N = 330	N = 328
ORR (partial responses only) (95% CI)	17% (13%, 22%)	3% (2%, 6%)	24% (19%, 29%)	4% (2%, 7%)
p-value ¹	p<0.0001		p<0.0001	
Partial Response	17%	3%	24%	4%
Median time to First Response, months (95% CI)	1.91 (1.6, 11.0)	2.14 (1.9, 9.20)	1.91 (1.3, 9.8)	3.50 (1.8, 5.6)
Stable Disease as Best Response	65%	62%	63%	63%
Progressive Disease as Best Response	12%	27%	9%	27%

¹ chi-squared test

A031203

The safety and efficacy of CABOMETYX for the treatment of treatment-naïve renal cell carcinoma were evaluated in a randomized, open-label, multicenter study (CABOSUN). Patients (N=157) with previously untreated, locally advanced or metastatic RCC with a clear cell component were randomized (1:1) to receive CABOMETYX (N=79) or sunitinib (N=78). Patients had to have

intermediate or poor risk disease as defined by the International Metastatic RCC Database Consortium (IMDC) risk group categories. Patients were stratified by IMDC risk group and presence of bone metastases (yes/no). Approximately 75% of patients had a nephrectomy prior to onset of treatment.

The baseline demographic and disease characteristics were similar between the CABOMETYX and sunitinib arms. The majority of the patients treated with CABOMETYX were male (84%) with a median age of 62 years. Patient distribution by IMDC risk groups was 81% intermediate (1-2 risk factors) and 19% poor (≥ 3 risk factors). Most patients (87%) had ECOG performance status of 0 or 1; 13% had an ECOG performance status of 2. Thirty-six percent (36%) of patients had bone metastases.

The primary efficacy endpoint was PFS retrospectively assessed by a blinded Independent Radiology Committee (IRC). Secondary efficacy endpoints were objective response rate (ORR) and overall survival (OS). Tumor assessments were conducted every 12 weeks.

A statistically significant improvement in PFS as retrospectively assessed by an IRC was demonstrated for CABOMETYX compared to sunitinib (Figure 3 and Table 12). The results from the Investigator determined analysis and IRC-determined analysis of PFS were consistent.

Based on exploratory subgroup analyses, patients with a positive MET status showed a favorable effect in PFS (HR: 0.32; 95% CI: 0.16 – 0.63) and OS (HR: 0.31; 95% CI: 0.14 – 0.69) with CABOMETYX when compared with sunitinib. However, when comparing CABOMETYX to sunitinib in patients with MET negative status the numerical benefit seen in the PFS (HR: 0.67; 95% CI: 0.37 - 1.3) did not translate into the prolongation of the OS (HR: 1.34; 95% CI: 0.67 - 2.70), and a negative trend of OS treatment effect was found. The study was not powered for the OS analysis.

Objective response rate (ORR) findings are summarized in Table 12.

Figure 3: Kaplan Meier Curve for Progression-Free Survival by IRC in Treatment-Naïve RCC Subjects

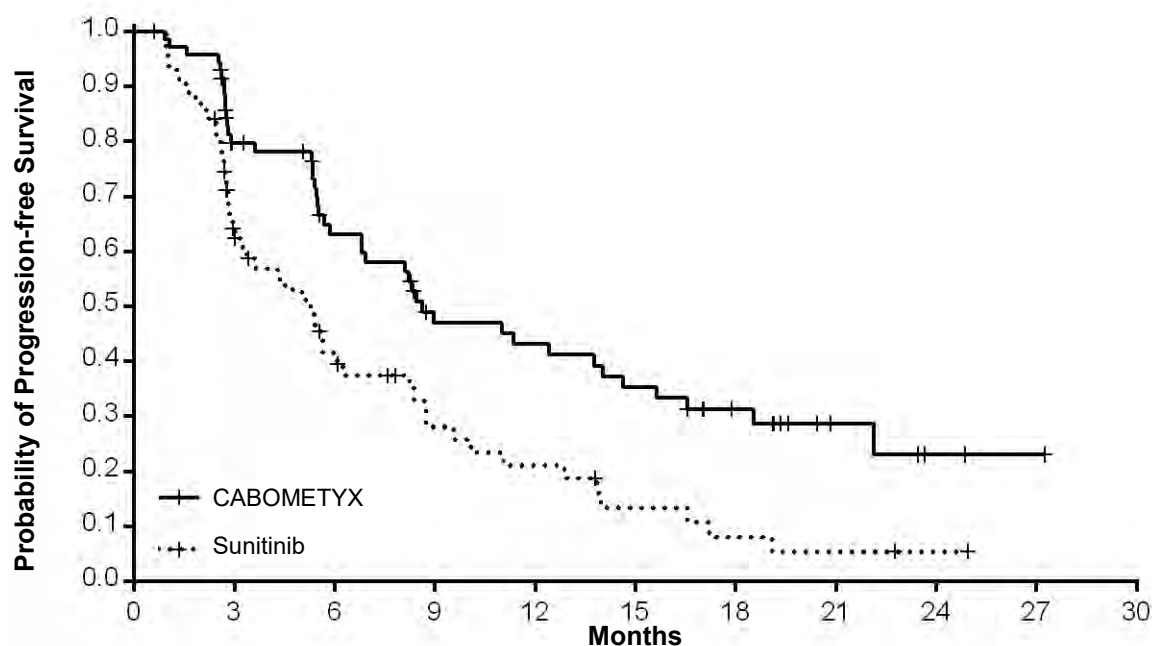

Number at risk:

CABOMETYX

Sunitinib

	0	3	6	9	12	15	18	21	24	27	30
CABOMETYX	79	51	37	24	22	18	12	5	2	1	0
Sunitinib	78	36	21	12	9	5	3	2	1	0	0

Table 12: Efficacy Results in Treatment-Naïve RCC Subjects (ITT population)

	CABOMETYX (N=79)	Sunitinib (N=78)
Progression-free survival (PFS) by IRC		
Median PFS in months (95% CI)	8.6 (6.8, 14.0)	5.3 (3.0, 8.2)
HR (95% CI); stratified ^{a, b}	0.48 (0.31, 0.74)	
Two-sided log-rank p-value: stratified ^b	p=0.0008	
Objective Response Rate n (%) by IRC		
Complete responses	0	0
Partial responses	16 (20)	7 (9)
ORR (partial responses only)	16 (20)	7 (9)
Stable disease	43 (54)	30 (38)
Progressive Disease	14 (18)	23 (29)

^aStratification factors per IxRS comprise IMDC risk categories (intermediate risk, poor risk and bone metastasis (yes, no))

^bEstimated using the Cox proportional hazard model adjusted for stratification factors per IxRS. Hazard ratio < 1 indicates PFS in favor of cabozantinib

XL184-309

The safety and efficacy of CABOMETYX were evaluated in a randomized, placebo-controlled,

double-blind study of CABOMETYX 60 mg once daily in subjects with advanced HCC who had received prior sorafenib. The study randomized a total of 707 patients, 470 to receive CABOMETYX and 237 to receive placebo. The median age was 64 years (range 22 to 86 years), 81% were male, 56% were White and 34% were Asian. Baseline ECOG performance status was 0 (52%) or 1 (48%). Etiology of HCC was HBV in 39% of patients and HCV in 28% of patients, and etiology was attributed to causes other than HBV or HCV in 40% of patients. Macroscopic vascular invasion or extra-hepatic tumor spread was present in 78% of patients. The majority of patients (98% and 99% in the CABOMETIX and placebo arms, respectively) had Child-Pugh A liver disease. All (100%) patients received prior sorafenib and 28% received two prior systemic therapy regimens. Randomization was stratified by etiology of disease (HBV [with or without HCV], HCV [without HBV], or other), geographic region (Asia, other regions) and by presence of extrahepatic spread of disease and/or macrovascular invasions (Yes, No).

The primary endpoint was duration of OS and secondary endpoints were duration of Investigator-determined PFS and ORR per RECIST 1.1. The analysis of the primary endpoint (OS) was based on a second planned interim analysis prespecified to be performed at approximately the 75% information fraction (i.e., at approximately 466 deaths). The median duration of follow up was 22.9 months. The primary analysis demonstrated a statistically significant improvement in duration of OS for subjects in the CABOMETYX arm compared with the placebo arm: the HR, adjusted for stratification factors, was 0.76 (95% CI: 0.63, 0.92; p-value =0.0049).

Table 13: Efficacy Results in HCC (ITT population, CELESTIAL)

	CABOMETYX (N=470)	Placebo (N=237)
Overall Survival		
Median OS (95% CI), months	10.2 (9.1, 12.0)	8.0 (6.8, 9.4)
HR (95% CI) ^{1,2}	0.76 (0.63, 0.92)	
p-value ¹	p=0.0049	
Progression-free survival (PFS) ³		
Median PFS in months (95% CI)	5.2 (4.0, 5.5)	1.9 (1.9, 1.9)
HR (95% CI) ¹	0.44 (0.36, 0.52)	
p-value ¹	p<0.0001	
Kaplan-Meier landmark estimates of percent of subjects event-free at 3 months		
% (95% CI)	67.0% (62.2%, 71.3%)	33.3% (27.1%, 39.7%)
Objective Response Rate n (%) ³		
Complete responses (CR)	0	0
Partial responses (PR)	18 (4)	1 (0.4)
ORR (CR+PR)	18 (4)	1 (0.4)
p-value ^{1,4}	p=0.0086	
Stable disease	282 (60)	78 (33)
Progressive Disease	98 (21)	131 (55)

¹ 2-sided stratified log-rank test with etiology of disease (HBV [with or without HCV], HCV [without HBV], or Other), geographic region (Asia, Other Regions), and presence of extrahepatic spread of disease and/or macrovascular invasion (Yes, No) as stratification factors (per IVRS data)

² Estimated using the Cox proportional-hazard model

³ As assessed by investigator per RECIST 1.1

⁴ Stratified Cochran-Mantel-Haenszel (CMH) test

Figure 4: Kaplan-Meier Curve of Overall Survival (CELESTIAL)

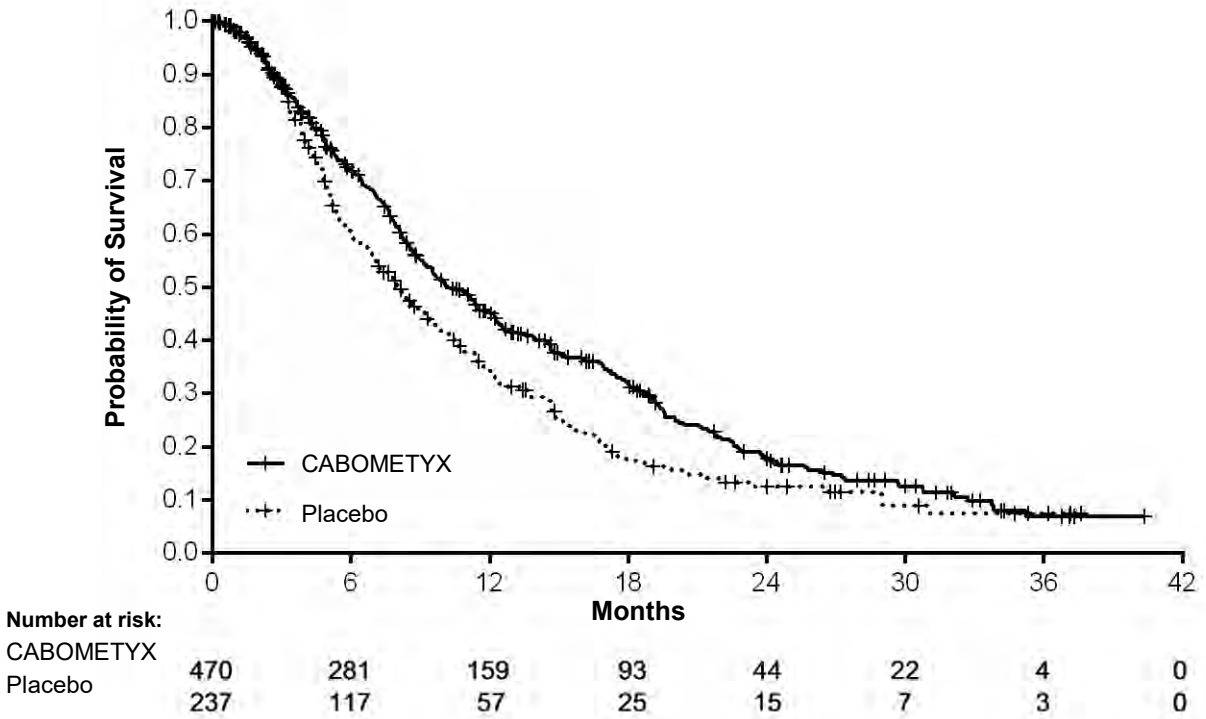
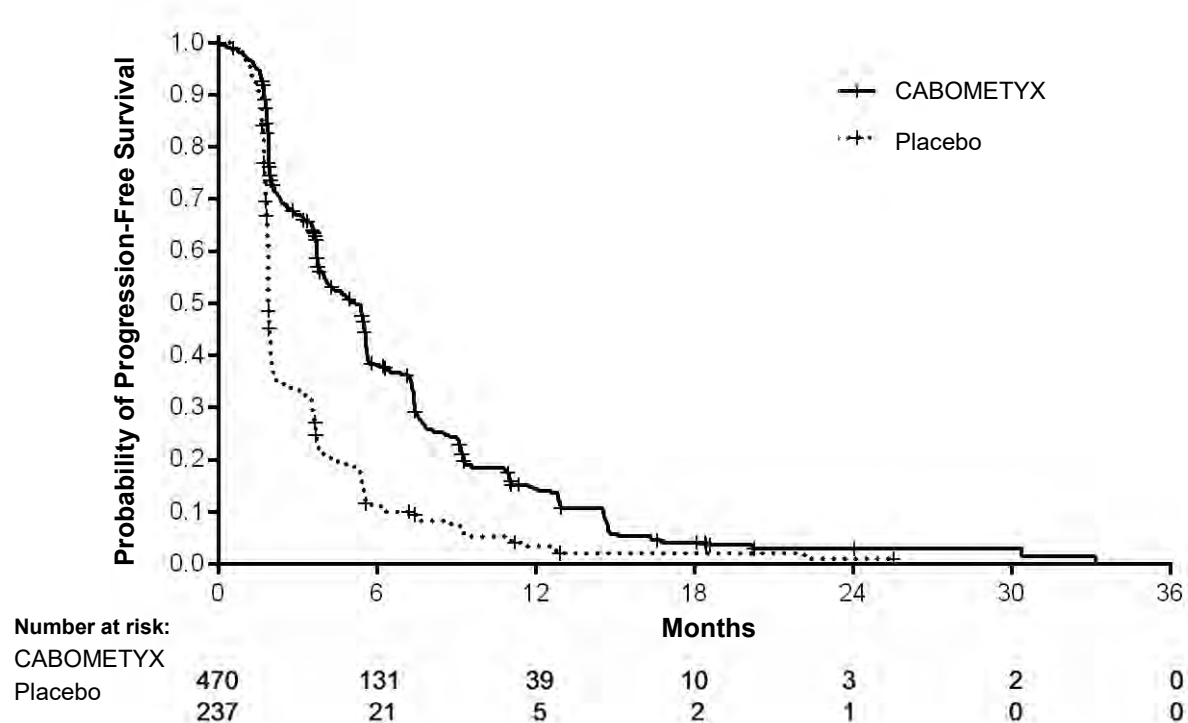

Figure 5: Kaplan Meier Curve for Progression-Free Survival (CELESTIAL)



14 NON-CLINICAL TOXICOLOGY

Single dose toxicity

Toxicity associated with single oral doses of cabozantinib in rats (100, 300 and 900 mg/kg) was characterized by dose-dependent clinical signs, clinical chemistry parameter changes reflective of possible hepatotoxicity, and hematologic parameters indicative of possible hematopoietic tissue toxicity. Histopathologic changes in gastrointestinal (GI) tract tissues, bone marrow, lymphoid tissue, and male and female reproductive tissues were considered cabozantinib-related. Minimal evidence of cabozantinib-related toxicity was observed in dogs administered single oral doses up to 2000 mg/kg (dose range: 30-2000 mg/kg/day).

Repeat dose toxicity

Repeat dose toxicity studies were performed in mice (4 weeks at 5, 15 and 50 mg/kg/day), rats (2 and 6 months at 0.1-15 mg/kg/day) and dogs (6 months at 0.2-30 mg/kg). Target organs for toxicity were lymphoid tissues, bone marrow, GI tract, kidney, adrenal and reproductive tract tissues. The no observed adverse effect level (NOAEL) yielded plasma exposures estimated to be below human clinical exposure levels at intended therapeutic dose (≥ 0.4 -fold, ≥ 0.2 -fold and $< 1\%$, for mice, rats and dogs, respectively).

Genotoxicity

Cabozantinib was not mutagenic in vitro in the bacterial reverse mutation (Ames) assay and was not clastogenic in both the in vitro cytogenetic assay using human lymphocytes or in the in vivo mouse micronucleus assay.

Carcinogenicity

Cabozantinib was not carcinogenic in a 26-week carcinogenicity study in rasH2 transgenic mice (2, 5 and 15 mg/kg/day).

During a 104-week carcinogenic study, Cabozantinib was daily administered at 0.1, 0.3 and 1.0 mg/kg/day in Sprague-Dawley rats. Cabozantinib-related neoplastic findings consisted of an increased incidence of benign pheochromocytoma, alone or in combination with malignant pheochromocytoma/complex malignant pheochromocytoma, of the adrenal medulla in males administered ≥ 0.1 mg/kg/day and females administered ≥ 0.3 mg/kg/day. In addition, increased incidence of hyperplasia of the adrenal medulla also occurred in females administered ≥ 0.1 mg/kg/day.

Reproductive and developmental toxicity

In reproductive and developmental toxicity studies, cabozantinib administration was associated with: reduced fertility in male and female rats (1, 2.5 and 5 mg/kg/day); embryotoxicity in rats (0.01, 0.03 and 0.1 mg/kg/day); fetal soft-tissue malformations (small spleen, missing lung lobe) in rabbits (0.3, 1 and 3.0 mg/kg/day); fetal skeletal malformations (cleft palate and kinked/rudimentary tail) at embryotoxic doses in rats (dose range: 0.03-7.5 mg/kg); and no fetal external or skeletal malformations in rabbits (0.3, 1.0 and 3.0 mg/kg/day). These effects were observed at exposures that were significantly lower than the human exposure at the therapeutic dose.

Target organs for toxicity in rat juvenile studies (dose range: 0.3-3 mg/kg/day) were bone, bone marrow, GI tract, lymphoid and reproductive organs. At the NOAEL (0.3 mg/kg/day) plasma exposures are estimated to be approximately 0.1-fold of the mean clinical exposure.

Phototoxicity in vitro studies

Cabozantinib was negative in an in vitro Balb/c mouse 3T3 fibroblast phototoxicity bioassay.

READ THIS FOR SAFE AND EFFECTIVE USE OF YOUR MEDICINE

PATIENT MEDICATION INFORMATION

Pr**CABOMETYX**[™] cabozantinib tablets

Read this carefully before you start taking **CABOMETYX** and each time you get a refill. This leaflet is a summary and will not tell you everything about this drug. Talk to your healthcare professional about your medical condition and treatment and ask if there is any new information about **CABOMETYX**.

Serious Warnings and Precautions

CABOMETYX should only be prescribed and used under the supervision of a healthcare professional experienced in drugs to treat cancer.

Serious side-effects with **CABOMETYX** can include:

- Life-threatening blood clots
- High blood pressure. Blood pressure can be severely high and could cause stroke (hypertensive crisis).
- Life-threatening tear in your stomach or intestinal wall (**perforation**) or abnormal connection between 2 parts of your body (**fistula**)
- Life-threatening bleeding
- Life-threatening liver injury
- A condition called **posterior reversible leukoencephalopathy syndrome**
- Abnormal wound healing

CABOMETYX has not been studied in patients with heart problems or severe kidney or liver problems.

What is **CABOMETYX used for?**

CABOMETYX is used to treat adults with:

- a type of advanced kidney cancer called renal cell carcinoma. Some of these patients may have had no previous treatment for their disease. Others may have been treated with medicines that block the growth of blood vessels (anti-angiogenic therapies).
- a type of liver cancer called hepatocellular carcinoma. These patients will have been previously treated with a medication called sorafenib.

How does **CABOMETYX work?**

CABOMETYX is a multi-kinase inhibitor. It works by blocking the action of proteins called receptor tyrosine kinases (RTKs). RTKs are involved in cell growth and the development of new blood vessels. These proteins can be present in high amounts in cancer cells. By blocking their action, **CABOMETYX** can slow down how fast the tumour grows, help to block the blood supply that the cancer needs and may increase the length of time before the cancer gets worse.

What are the ingredients in **CABOMETYX?**

Medicinal ingredient: cabozantinib (S)-malate

Non-medicinal ingredients: colloidal silicon dioxide, croscarmellose sodium, hydroxypropyl cellulose, hypromellose 2910, iron oxide yellow, lactose anhydrous, magnesium stearate, microcrystalline cellulose, titanium dioxide and triacetin

CABOMETYX comes in the following dosage forms:

Tablets: 20 mg, 40 mg, 60 mg cabozantinib (as cabozantinib (S)-malate)

Do not use CABOMETYX if:

You are allergic to cabozantinib or any other ingredients in this medicine including lactose anhydrous.

To help avoid side effects and ensure proper use, talk to your healthcare professional before you take CABOMETYX. Talk about any health conditions or problems you may have, including if you:

- have high blood pressure and its complications, including separation of the layers of an artery wall (artery dissection)
- have heart disease
- have diarrhea
- have any unusual bleeding
- plan to have any surgery, including dental surgery. You should stop treatment with CABOMETYX at least 28 days before any scheduled surgery.
- have liver or kidney disease, including increased amounts of protein in your urine
- have inflammatory bowel disease (for example Crohn's disease or ulcerative colitis, diverticulitis, or appendicitis)
- have had a blood clot in the leg, lungs or liver, stroke, or heart attack
- have any heart disorder, including an irregular heartbeat, prolongation of the QT interval or a family history of QT prolongation or sudden cardiac death at less than 50 years of age
- have thyroid problems
- are pregnant, or plan to become pregnant. Avoid getting pregnant while taking CABOMETYX, as it can harm your unborn baby.
 - Female patients who are able to become pregnant, should use effective methods of birth control during treatment and for 4 months after your last dose of CABOMETYX.
 - Talk to your healthcare provider about birth control methods that may be right for you.
 - If you become pregnant or think you are pregnant, tell your healthcare provider right away.
- are a male patient with a female partner who is able to become pregnant. Your female partner should avoid getting pregnant while you are taking CABOMETYX.
 - Effective birth control should be used during treatment with CABOMETYX and for 4 months after your last dose.
 - Tell your healthcare professional right away if your partner becomes pregnant while you are receiving treatment with CABOMETYX.
- are breastfeeding or plan to breastfeed. It is not known if CABOMETYX passes into your breast milk. Do not breastfeed during treatment and for 4 months after your last dose of CABOMETYX.

Driving and using machines: Before you do tasks which may require special attention, wait until you know how you respond to CABOMETYX. If you feel dizzy, weak, or tired, do not drive or use tools or machines.

Tell your healthcare professional about all the medicines you take, including any drugs, vitamins, minerals, natural supplements or alternative medicines.

The following may interact with CABOMETYX:

- Medicines that treat fungal infections, such as itraconazole, ketoconazole, and posaconazole
- Medicines used to treat bacterial infections (antibiotics) such as erythromycin, clarithromycin, and rifampicin
- Allergy medicines such as fexofenadine
- Medicines used to treat epilepsy or fits such as phenytoin, carbamazepine, and phenobarbital
- Herbal preparations containing St. John's Wort (*Hypericum perforatum*), sometimes used for treating depression or depression-related conditions such as anxiety
- Medicines used to thin the blood, such as warfarin, dabigatran, etexilate
- Medicines to treat high blood pressure or other heart conditions, such as ambrisentan, aliskeren, talinolol, digoxin, and tolvaptan
- Medicines for diabetes, such as saxagliptin and sitagliptin
- Medicines used to treat gout, such as colchicine
- Medicines used to treat HIV or AIDS, such as efavirenz, ritonavir, maraviroc and emtricitabine
- Medicines used to lower high cholesterol in the blood or to remove substances called bile acids from your body, such as cholestyramin and cholestagel
- Medicines that may lengthen the QT-interval of your heart, such as certain drugs to treat heart conditions, psychosis, depression, pain, infections and other conditions
- Medicines that may affect the levels of electrolytes in your body, such as certain diuretics, laxatives, enemas and corticosteroids

How to take CABOMETYX:

- Always take CABOMETYX exactly as your healthcare professional tells you to take it.
- Take CABOMETYX once a day on an empty stomach. Do not eat for at least 2 hours before and at least 1 hour after taking the dose.
- Swallow tablets whole with a full glass (at least 8 ounces) of water.
- **Do not** crush tablets.
- Take your medicine at about the same time each day.
- Do not drink grapefruit juice or eat grapefruit while taking CABOMETYX. Do not take supplements that contain grapefruit while taking CABOMETYX.

Usual adult dose:

60 mg tablet, once a day. Your healthcare professional will decide on the right dose for you.

Your doctor may adjust your dose or stop treatment for some time (then resume at the same or a lower dose). This may happen if you:

- have surgery
- have problems with your liver
- have certain side effects while taking CABOMETYX

Overdose:

If you think you have taken too much CABOMETYX, contact your healthcare professional, hospital emergency department or regional Poison Control Centre immediately, even if there are no symptoms.

Missed Dose:

If you miss a dose and your next dose is in:

- less than 12 hours, take your next dose at its scheduled time. Do not make up the missed dose.
- 12 hours or more, take the missed dose as soon as you remember. Take your next dose at the normal time.

What are possible side effects from using CABOMETYX?

These are not all the possible side effects you may feel when taking CABOMETYX. If you experience any side effects not listed here, contact your healthcare professional.

- Stomach upset, including diarrhea, nausea, vomiting, constipation, indigestion, and abdominal pain
- Decreased appetite
- Weight loss
- Altered sense of taste
- Heartburn (bringing up stomach acid)
- Redness, swelling or pain in the mouth or throat
- Rash or redness of the skin
- Dry skin and mouth
- Fatigue, insomnia
- Weakness
- Headache
- Fever
- Dizziness, fainting
- Pain in arms, legs and joints, muscle spasms
- Shortness of breath
- Difficulty in speaking, hoarseness
- Cough
- Hair loss
- Swelling in lower legs or hands
- Weakness or numbness in hands or feet

CABOMETYX can cause abnormal blood and urine test results. Your healthcare professional will decide when to perform blood or urine tests and will interpret the results.

Serious side effects and what to do about them			
Symptom / effect	Talk to your healthcare professional		Stop taking drug and get immediate medical help
	Only if severe	In all cases	
VERY COMMON			
Hand-foot skin reaction: redness, blisters, pain in the palms of the hands or soles of the feet	X		
Ascites (fluid in the abdomen): abdominal pain, feeling of fullness, flat or pushed out navel, weight increase, shortness of breath		X	
Hypertension (high blood pressure): headaches, vision problems, nausea and vomiting	X		
Anemia (low levels of red blood cells): fatigue, having pale skin, shortness of breath, loss of energy or weakness	X		
Hypothyroidism (underactive thyroid gland): changes in heart rate, appetite or weight, tiredness, constipation, feeling cold, dry skin, swelling at front of neck		X	
Hyponatremia (low level of sodium in your blood): loss of energy, tiredness, muscle weakness or cramps, seizures	X		
Hypophosphatemia (low level of phosphate in the blood): muscle weakness, coma, bone pain and fractures	X		
Hypomagnesemia (low level of magnesium in the blood): nausea, vomiting, weakness, muscle spasms, tremors	X		
Hypokalemia (low level of potassium in the blood): muscle weakness, cramping	X		
Decreased lymphocytes (low level of white blood cells): swollen lymph nodes, painful swollen joints and rash	X		
Proteinuria (too much protein in your urine): swelling of the hands, feet, face	X		
COMMON			
Thromboembolism (blood clot in a vein or artery): pain or tenderness or swelling in your arm or leg, skin that is red or warm, coldness, tingling or numbness, pale skin, muscle pain or spasms, weakness			X
Severe hemorrhage (bleeding): vomiting blood, black stools, bloody urine, headache, coughing up blood			X
Gastrointestinal perforation (tear in your stomach or intestinal wall): abdominal pain, feeling sick, vomiting, constipation, fever			X

Hypocalcemia (low level of calcium in the blood): numbness and tingling in the hands, feet or lips, muscle cramping or spasms, lightheadedness, slow heartbeat	X		
Dehydration (condition that happens when you lose more fluid than you take in): thirst, headache, loss of appetite, tiredness, weakness, decreased urine, dark urine	X		
Thrombocytopenia (low level of platelets in the blood): bruising easily, bleeding gums, nosebleeds, more bleeding than expected.	X		
Hepatic encephalopathy (worsening brain function due to liver issues): change in alertness, confusion, mood or personality changes, disorientation, changes in sleep patterns, loss of consciousness, coma		X	
UNCOMMON Convulsion: Fits (seizures), headaches, confusion, or struggling to focus			X
Anal fistula (abnormal connection between the anus and another part of your body): pain and swelling around the anus, pain with bowel movements, bleeding, bloody or foul smelling discharge from the anus, fever, chills	X		
Pancreatitis (inflammation of the pancreas): abdominal pain that lasts or gets worse when you lie down, nausea, vomiting	X		
Liver injury: yellowing of the skin or eyes, dark urine, abdominal pain, nausea, vomiting, loss of appetite, itching, bruising, weight loss			X
Hepatitis cholestatic (decrease in bile flow from the liver): yellow skin or eyes	X		
Pulmonary Embolism (blood clot in the lungs): sharp chest pain, coughing up blood, sudden shortness of breath			X
Pleural effusion (build-up of fluid around the lung): chest pain, dry cough, fever, difficulty breathing, shortness of breath			X
Osteonecrosis (bone damage in the jaw): pain in the mouth, teeth and/or jaw, swelling or sores inside the mouth, numbness or a feeling of heaviness in the jaw, or loosening of a tooth		X	
Wound complication: a wound that does not heal		X	
VERY RARE		X	

Artery Dissection (separation of the layers of an artery wall): sudden severe pain in the back, chest or abdomen			
Artery Aneurysm (a bulge in the wall of any artery including in the chest, arms, legs, heart, and brain): symptoms will differ by the site. They can be cough, coughing up blood, strong pain high in your neck or in your back when you didn't hurt yourself, problems swallowing, hoarse voice, unusual pulsing in your chest or abdomen.		X	
UNKNOWN QT Prolongation (an abnormal heart signal): irregular heartbeat, fainting, loss of consciousness			X
Reversible posterior leukoencephalopathy syndrome: headache, confusion, seizures (fits), visual problems			X

If you have a troublesome symptom or side effect that is not listed here or becomes bad enough to interfere with your daily activities, talk to your healthcare professional.

Reporting Side Effects

You can report any suspected side effects associated with the use of health products to Health Canada by:

- Visiting the Web page on Adverse Reaction Reporting (<https://www.canada.ca/en/health-canada/services/drugs-health-products/medeffect-canada/adverse-reaction-reporting.html>) for information on how to report online, by mail or by fax; or
- Calling toll-free at 1-866-234-2345.

NOTE: Contact your healthcare professional if you need information about how to manage your side effects. The Canada Vigilance Program does not provide medical advice.

Storage:

Store at 15°C to 25°C. Keep out of reach and sight of children.

If you want more information about CABOMETRYX:

- Talk to your healthcare professional
- Find the full product monograph that is prepared for healthcare professionals and includes this Patient Medication Information by visiting the [Health Canada website](https://www.canada.ca/en/health-canada.html) (<https://www.canada.ca/en/health-canada.html>); the manufacturer's website at www.ipsen.ca or by calling 1-855-215-2288.

This leaflet was prepared by Ipsen Biopharmaceuticals Canada Inc.

Last Revised: May 7, 2020

HIGHLIGHTS OF PRESCRIBING INFORMATION

These highlights do not include all the information needed to use CABOMETYX safely and effectively. See full prescribing information for CABOMETYX.

CABOMETYX® (cabozantinib) tablets, for oral use

Initial U.S. Approval: 2012

RECENT MAJOR CHANGES

Warnings and Precautions, Impaired Wound Healing (5.9) 1/2020

INDICATIONS AND USAGE

CABOMETYX is a kinase inhibitor indicated for the treatment of

- patients with advanced renal cell carcinoma (RCC) (1.1)
- patients with hepatocellular carcinoma (HCC) who have been previously treated with sorafenib (1.2)

DOSAGE AND ADMINISTRATION

- Recommended Dose: 60 mg orally, once daily. (2.2, 2.3)
- Administer at least 1 hour before or at least 2 hours after eating. (2.1)
- Do NOT substitute CABOMETYX tablets with cabozantinib capsules. (2.1)

DOSAGE FORMS AND STRENGTHS

Tablets: 20 mg, 40 mg, and 60 mg. (3)

CONTRAINDICATIONS

None. (4)

WARNINGS AND PRECAUTIONS

- Hemorrhage: Do not administer CABOMETYX if recent history of hemorrhage. (5.1)
- Perforations and Fistulas: Monitor for symptoms. Discontinue CABOMETYX for Grade 4 fistula or perforation. (5.2)
- Thrombotic Events: Discontinue CABOMETYX for myocardial infarction or serious venous or arterial thromboembolic events. (5.3)
- Hypertension and Hypertensive Crisis: Monitor blood pressure regularly. Interrupt for hypertension that is not adequately controlled with anti-hypertensive therapy. Discontinue CABOMETYX for hypertensive crisis or severe hypertension that cannot be controlled with anti-hypertensive therapy. (5.4)
- Diarrhea: May be severe. Interrupt CABOMETYX immediately until diarrhea resolves or decreases to Grade 1. Recommend standard antidiarrheal treatments. (5.5)

- Palmar-Plantar Erythrodysesthesia (PPE): Interrupt CABOMETYX treatment until PPE resolves or decreases to Grade 1. (5.6)
- Proteinuria: Monitor urine protein. Discontinue for nephrotic syndrome. (5.7)
- Osteonecrosis of the jaw (ONJ): Withhold CABOMETYX for at least 3 weeks prior to invasive dental procedures and for development of ONJ. (5.8)
- Impaired Wound Healing: Withhold CABOMETYX for at least 3 weeks before elective surgery. Do not administer for at least 2 weeks following major surgery and adequate wound healing. The safety of resumption of CABOMETYX after resolution of wound healing complications has not been established. (5.9)
- Reversible Posterior Leukoencephalopathy Syndrome (RPLS): Discontinue CABOMETYX. (5.10)
- Embryo-Fetal Toxicity: Can cause fetal harm. Advise females of reproductive potential of the potential risk to a fetus and to use effective contraception. (5.11, 8.1, 8.3)

ADVERSE REACTIONS

The most common ($\geq 25\%$) adverse reactions are: diarrhea, fatigue, decreased appetite, palmar-plantar erythrodysesthesia (PPE), nausea, hypertension, and vomiting. (6.1)

To report SUSPECTED ADVERSE REACTIONS, contact Exelixis, Inc. at 1-855-500-3935 or FDA at 1-800-FDA-1088 or www.fda.gov/medwatch.

DRUG INTERACTIONS

- Strong CYP3A4 inhibitors: Reduce the CABOMETYX dosage if coadministration cannot be avoided. (2.5, 7.1)
- Strong CYP3A4 inducers: Increase the CABOMETYX dosage if coadministration cannot be avoided. (2.6, 7.1)

USE IN SPECIFIC POPULATIONS

- Hepatic Impairment: Reduce the CABOMETYX dosage for patients with moderate hepatic impairment. Avoid in patients with severe hepatic impairment. (2.7, 8.6)
- Lactation: Advise not to breastfeed. (8.2)

See 17 for PATIENT COUNSELING INFORMATION and FDA-approved patient labeling.

Revised: 7/2020

FULL PRESCRIBING INFORMATION: CONTENTS*

1	INDICATIONS AND USAGE	5.11	Embryo-Fetal Toxicity
	1.1 Renal Cell Carcinoma	6	ADVERSE REACTIONS
	1.2 Hepatocellular Carcinoma	6.1	Clinical Trial Experience
2	DOSAGE AND ADMINISTRATION	6.2	Postmarketing Experience
	2.1 Important Dosage Information	7	DRUG INTERACTIONS
	2.2 Recommended Dosage for Renal Cell Carcinoma	7.1	Effects of Other Drugs on CABOMETYX
	2.3 Recommended Dosage for Hepatocellular Carcinoma	8	USE IN SPECIFIC POPULATIONS
	2.4 Dosage Modifications for Adverse Reactions	8.1	Pregnancy
	2.5 Dosage Modifications for Coadministration with Strong CYP3A4 Inhibitors	8.2	Lactation
	2.6 Dosage Modifications for Coadministration with Strong CYP3A4 Inducers	8.3	Females and Males of Reproductive Potential
	2.7 Dosage Modifications for Patients with Moderate and Severe Hepatic Impairment	8.4	Pediatric Use
3	DOSAGE FORMS AND STRENGTHS	8.5	Geriatric Use
4	CONTRAINDICATIONS	8.6	Hepatic Impairment
5	WARNINGS AND PRECAUTIONS	8.7	Renal Impairment
	5.1 Hemorrhage	10	OVERDOSAGE
	5.2 Perforations and Fistulas	11	DESCRIPTION
	5.3 Thrombotic Events	12	CLINICAL PHARMACOLOGY
	5.4 Hypertension and Hypertensive Crisis	12.1	Mechanism of Action
	5.5 Diarrhea	12.2	Pharmacodynamics
	5.6 Palmar-Plantar Erythrodysesthesia	12.3	Pharmacokinetics
	5.7 Proteinuria	13	NONCLINICAL TOXICOLOGY
	5.8 Osteonecrosis of the Jaw	13.1	Carcinogenesis, Mutagenesis, Impairment of Fertility
	5.9 Impaired Wound Healing	14	CLINICAL STUDIES
	5.10 Reversible Posterior Leukoencephalopathy Syndrome	14.1	Renal Cell Carcinoma
		14.2	Hepatocellular Carcinoma
		16	HOW SUPPLIED/STORAGE AND HANDLING
		17	PATIENT COUNSELING INFORMATION

*Sections or subsections omitted from the full prescribing information are not listed.

FULL PRESCRIBING INFORMATION

1 INDICATIONS AND USAGE

1.1 Renal Cell Carcinoma

CABOMETYX is indicated for the treatment of patients with advanced renal cell carcinoma (RCC).

1.2 Hepatocellular Carcinoma

CABOMETYX is indicated for the treatment of patients with hepatocellular carcinoma (HCC) who have been previously treated with sorafenib.

2 DOSAGE AND ADMINISTRATION

2.1 Important Dosage Information

- Stop treatment with CABOMETYX at least 3 weeks prior to scheduled surgery, including dental surgery [see *Warnings and Precautions (5.1, 5.8, 5.9)*].
- Do not substitute CABOMETYX tablets with cabozantinib capsules.
- Do not administer CABOMETYX with food. Administer at least 1 hour before or at least 2 hours after eating [see *Clinical Pharmacology (12.3)*].
- Swallow CABOMETYX tablets whole. Do not crush CABOMETYX tablets.
- Do not take a missed dose within 12 hours of the next dose.
- Modify the dose for certain patients with hepatic impairment and for patients taking drugs known to strongly induce or inhibit CYP450 [see *Dosage and Administration (2.5, 2.6, 2.7)*].

2.2 Recommended Dosage for Renal Cell Carcinoma

The recommended dosage of CABOMETYX is 60 mg once daily without food until the patient no longer experiences clinical benefit or experiences unacceptable toxicity.

2.3 Recommended Dosage for Hepatocellular Carcinoma

The recommended dosage of CABOMETYX is 60 mg once daily without food until disease progression or unacceptable toxicity.

2.4 Dosage Modifications for Adverse Reactions

Withhold CABOMETYX for:

- Intolerable Grade 2 adverse reactions
- Grade 3 or 4 adverse reactions
- Osteonecrosis of the jaw

Upon resolution/improvement (i.e., return to baseline or resolution to Grade 1) of an adverse reaction, reduce the dose as follows:

- If previously receiving 60 mg daily dose, resume treatment at 40 mg daily.
- If previously receiving 40 mg daily dose, resume treatment at 20 mg daily.
- If previously receiving 20 mg daily dose, resume at 20 mg if tolerated, otherwise, discontinue CABOMETYX.

Permanently discontinue CABOMETYX for any of the following:

- Severe hemorrhage
- Development of gastrointestinal (GI) perforation or Grade 4 fistula
- Acute myocardial infarction or arterial or venous thromboembolic events that require medical intervention
- Severe hypertension that cannot be controlled with anti-hypertensive therapy or hypertensive crisis
- Nephrotic syndrome
- Reversible posterior leukoencephalopathy syndrome

2.5 Dosage Modifications for Coadministration with Strong CYP3A4 Inhibitors

Reduce the daily CABOMETYX dose by 20 mg (for example, from 60 mg to 40 mg daily or from 40 mg to 20 mg daily). Resume the dose that was used prior to initiating the strong CYP3A4 inhibitor 2 to 3 days after discontinuation of the strong inhibitor [*see Drug Interactions (7.1), Clinical Pharmacology (12.3)*].

2.6 Dosage Modifications for Coadministration with Strong CYP3A4 Inducers

Increase the daily CABOMETYX dose by 20 mg (for example, from 60 mg to 80 mg daily or from 40 mg to 60 mg daily) as tolerated. Resume the dose that was used prior to initiating the strong CYP3A4 inducer 2 to 3 days after discontinuation of the strong inducer. Do not exceed a daily dose of 80 mg [*see Drug Interactions (7.1), Clinical Pharmacology (12.3)*].

2.7 Dosage Modifications for Patients with Moderate and Severe Hepatic Impairment

Reduce the starting dose of CABOMETYX to 40 mg once daily in patients with moderate hepatic impairment (Child-Pugh B). Avoid CABOMETYX in patients with severe hepatic impairment (Child-Pugh C) [*see Use in Specific Populations (8.6), Clinical Pharmacology (12.3)*].

3 DOSAGE FORMS AND STRENGTHS

Tablets:

- 60 mg: yellow film-coated, oval shaped with no score, and debossed with “XL” on one side and “60” on the other side.
- 40 mg: yellow film-coated, triangle shaped with no score, and debossed with “XL” on one side and “40” on the other side.
- 20 mg: yellow film-coated, round with no score, and debossed with “XL” on one side and “20” on the other side.

4 CONTRAINDICATIONS

None.

5 WARNINGS AND PRECAUTIONS

5.1 Hemorrhage

Severe and fatal hemorrhages occurred with CABOMETYX [see *Adverse Reactions (6.1)*]. The incidence of Grade 3 to 5 hemorrhagic events was 5% in CABOMETYX-treated patients in RCC and HCC studies.

Discontinue CABOMETYX for Grade 3 or 4 hemorrhage [see *Dosage and Administration (2.4)*]. Do not administer CABOMETYX to patients who have a recent history of hemorrhage, including hemoptysis, hematemesis, or melena.

5.2 Perforations and Fistulas

Fistulas, including fatal cases, occurred in 1% of CABOMETYX-treated patients [see *Adverse Reactions (6.1)*]. Gastrointestinal (GI) perforations, including fatal cases, occurred in 1% of CABOMETYX-treated patients.

Monitor patients for signs and symptoms of fistulas and perforations, including abscess and sepsis. Discontinue CABOMETYX in patients who experience a Grade 4 fistula or a GI perforation [see *Dosage and Administration (2.4)*].

5.3 Thrombotic Events

CABOMETYX increased the risk of thrombotic events [see *Adverse Reactions (6.1)*]. Venous thromboembolism occurred in 7% (including 4% pulmonary embolism) and arterial thromboembolism occurred in 2% of CABOMETYX-treated patients. Fatal thrombotic events occurred in CABOMETYX-treated patients.

Discontinue CABOMETYX in patients who develop an acute myocardial infarction or serious arterial or venous thromboembolic events that require medical intervention [see *Dosage and Administration (2.4)*].

5.4 Hypertension and Hypertensive Crisis

CABOMETYX can cause hypertension, including hypertensive crisis [see *Adverse Reactions (6.1)*]. Hypertension was reported in 36% (17% Grade 3 and <1% Grade 4) of CABOMETYX-treated patients.

Do not initiate CABOMETYX in patients with uncontrolled hypertension. Monitor blood pressure regularly during CABOMETYX treatment. Withhold CABOMETYX for hypertension that is not adequately controlled with medical management; when controlled, resume CABOMETYX at a reduced dose [see *Dosage and Administration (2.4)*]. Discontinue CABOMETYX for severe hypertension that cannot be controlled with anti-hypertensive therapy or for hypertensive crisis.

5.5 Diarrhea

Diarrhea occurred in 63% of patients treated with CABOMETYX. Grade 3 diarrhea occurred in 11% of patients treated with CABOMETYX [see *Adverse Reactions (6.1)*].

Withhold CABOMETYX until improvement to Grade 1 and resume CABOMETYX at a reduced dose for intolerable Grade 2 diarrhea, Grade 3 diarrhea that cannot be managed with standard antidiarrheal treatments, or Grade 4 diarrhea [see *Dosage and Administration (2.4)*].

5.6 Palmar-Plantar Erythrodysesthesia

Palmar-plantar erythrodysesthesia (PPE) occurred in 44% of patients treated with CABOMETYX [see *Adverse Reactions (6.1)*]. Grade 3 PPE occurred in 13% of patients treated with CABOMETYX.

Withhold CABOMETYX until improvement to Grade 1 and resume CABOMETYX at a reduced dose for intolerable Grade 2 PPE or Grade 3 PPE [see *Dosage and Administration (2.4)*].

5.7 Proteinuria

Proteinuria was observed in 7% of patients receiving CABOMETYX [see *Adverse Reactions (6.1)*]. Monitor urine protein regularly during CABOMETYX treatment. Discontinue CABOMETYX in patients who develop nephrotic syndrome [see *Dosage and Administration (2.4)*].

5.8 Osteonecrosis of the Jaw

Osteonecrosis of the jaw (ONJ) occurred in <1% of patients treated with CABOMETYX [see *Adverse Reactions (6.1)*]. ONJ can manifest as jaw pain, osteomyelitis, osteitis, bone erosion, tooth or periodontal infection, toothache, gingival ulceration or erosion, persistent jaw pain or slow healing of the mouth or jaw after dental surgery. Perform an oral examination prior to initiation of CABOMETYX and periodically during CABOMETYX. Advise patients regarding good oral hygiene practices. Withhold CABOMETYX for at least 3 weeks prior to scheduled dental surgery or invasive dental procedures, if possible. Withhold CABOMETYX for development of ONJ until complete resolution [see *Dosage and Administration (2.1)*].

5.9 Impaired Wound Healing

Wound complications occurred with CABOMETYX [see *Adverse Reactions (6.1)*]. Withhold CABOMETYX for at least 3 weeks prior to elective surgery [see *Dosage and Administration (2.1)*]. Do not administer CABOMETYX for at least 2 weeks after major surgery and until adequate wound healing. The safety of resumption of CABOMETYX after resolution of wound healing complications has not been established.

5.10 Reversible Posterior Leukoencephalopathy Syndrome

Reversible Posterior Leukoencephalopathy Syndrome (RPLS), a syndrome of subcortical vasogenic edema diagnosed by characteristic finding on MRI, can occur with CABOMETYX. Perform an evaluation for RPLS in any patient presenting with seizures, headache, visual disturbances, confusion or altered mental function. Discontinue CABOMETYX in patients who develop RPLS [see *Dosage and Administration (2.4)*].

5.11 Embryo-Fetal Toxicity

Based on data from animal studies and its mechanism of action, CABOMETYX can cause fetal harm when administered to a pregnant woman. Cabozantinib administration to pregnant animals during organogenesis resulted in embryoletality at exposures below those occurring clinically at the recommended dose, and in increased incidences of skeletal variations in rats and visceral variations and malformations in rabbits.

Advise pregnant women of the potential risk to a fetus. Advise females of reproductive potential to use effective contraception during treatment with CABOMETYX and for 4 months after the last dose [see *Use in Specific Populations (8.1, 8.3)*, *Clinical Pharmacology (12.1)*].

6 ADVERSE REACTIONS

The following clinically significant adverse reactions are discussed elsewhere in the labeling:

- Hemorrhage [see *Warnings and Precautions (5.1)*]
- Perforations and Fistulas [see *Warnings and Precautions (5.2)*]
- Thrombotic Events [see *Warnings and Precautions (5.3)*]
- Hypertension and Hypertensive Crisis [see *Warnings and Precautions (5.4)*]
- Diarrhea [see *Warnings and Precautions (5.5)*]
- Palmar-plantar Erythrodysesthesia [see *Warnings and Precautions (5.6)*]
- Proteinuria [see *Warnings and Precautions (5.7)*]
- Osteonecrosis of the Jaw [see *Warnings and Precautions (5.8)*]
- Impaired Wound Healing [see *Warnings and Precautions (5.9)*]
- Reversible Posterior Leukoencephalopathy Syndrome [see *Warnings and Precautions (5.10)*]

6.1 Clinical Trial Experience

The data described in the WARNINGS AND PRECAUTIONS section and below reflect exposure to CABOMETYX as a single agent in 409 patients with RCC enrolled in randomized,

active-controlled trials (CABOSUN, METEOR) and 467 patients with HCC enrolled in a randomized, placebo-controlled trial (CELESTIAL).

Because clinical trials are conducted under widely varying conditions, adverse reaction rates observed in the clinical trials of a drug cannot be directly compared to rates in the clinical trials of another drug and may not reflect the rates observed in practice.

Renal Cell Carcinoma

METEOR

The safety of CABOMETYX was evaluated in METEOR, a randomized, open-label trial in which 331 patients with advanced renal cell carcinoma received CABOMETYX 60 mg once daily and 322 patients received everolimus 10 mg once daily until disease progression or unacceptable toxicity. Patients on both arms who had disease progression could continue treatment at the discretion of the investigator [see *Clinical Studies (14.1)*]. The median duration of treatment was 7.6 months (range 0.3 – 20.5) for patients receiving CABOMETYX and 4.4 months (range 0.21 – 18.9) for patients receiving everolimus.

Adverse reactions which occurred in $\geq 25\%$ of CABOMETYX-treated patients, in order of decreasing frequency, were: diarrhea, fatigue, nausea, decreased appetite, palmar-plantar erythrodysesthesia (PPE), hypertension, vomiting, weight decreased, and constipation. Grade 3-4 adverse reactions and laboratory abnormalities which occurred in $\geq 5\%$ of patients were hypertension, diarrhea, fatigue, PPE, hyponatremia, hypophosphatemia, hypomagnesemia, lymphopenia, anemia, hypokalemia, and increased GGT.

The dose was reduced in 60% of patients receiving CABOMETYX and in 24% of patients receiving everolimus. Twenty percent (20%) of patients received CABOMETYX 20 mg once daily as their lowest dose. The most frequent adverse reactions leading to dose reduction in patients treated with CABOMETYX were: diarrhea, PPE, fatigue, and hypertension. Adverse reactions leading to dose interruption occurred in 70% patients receiving CABOMETYX and in 59% patients receiving everolimus. Adverse reactions led to study treatment discontinuation in 10% of patients receiving CABOMETYX and in 10% of patients receiving everolimus. The most frequent adverse reactions leading to permanent discontinuation in patients treated with CABOMETYX were decreased appetite (2%) and fatigue (1%).

Table 1. Adverse Reactions Occurring in $\geq 10\%$ Patients Who Received CABOMETYX in METEOR

Adverse Reaction	CABOMETYX (n=331) ¹		Everolimus (n=322)	
	All Grades ²	Grade 3-4	All Grades ²	Grade 3-4
	Percentage (%) of Patients			
Gastrointestinal				
Diarrhea	74	11	28	2
Nausea	50	4	28	<1
Vomiting	32	2	14	<1
Stomatitis	22	2	24	2
Constipation	25	<1	19	<1
Abdominal pain ³	23	4	13	2
Dyspepsia	12	<1	5	0

Adverse Reaction	CABOMETYX (n=331) ¹		Everolimus (n=322)	
	All Grades ²	Grade 3-4	All Grades ²	Grade 3-4
	Percentage (%) of Patients			
General				
Fatigue	56	9	47	7
Mucosal inflammation	19	<1	23	3
Asthenia	19	4	16	2
Metabolism and Nutrition				
Decreased appetite	46	3	34	<1
Skin and Subcutaneous Tissue				
Palmar-plantar erythrodysesthesia	42	8	6	<1
Rash ⁴	23	<1	43	<1
Dry skin	11	0	10	0
Vascular				
Hypertension ⁵	39	16	8	3
Investigations				
Weight decreased	31	2	12	0
Nervous System				
Dysgeusia	24	0	9	0
Headache	11	<1	12	<1
Dizziness	11	0	7	0
Endocrine				
Hypothyroidism	21	0	<1	<1
Respiratory, Thoracic, and Mediastinal				
Dysphonia	20	<1	4	0
Dyspnea	19	3	29	4
Cough	18	<1	33	<1
Blood and Lymphatic				
Anemia	17	5	38	16
Musculoskeletal and Connective Tissue				
Pain in extremity	14	1	8	<1
Muscle spasms	13	0	5	0
Arthralgia	11	<1	14	1
Renal and Urinary				
Proteinuria	12	2	9	<1

¹ One subject randomized to everolimus received cabozantinib.

² National Cancer Institute (NCI) Common Terminology Criteria for Adverse Events (CTCAE) Version 4.0

³ Includes the following terms: abdominal pain, abdominal pain upper, and abdominal pain lower

⁴ Includes the following terms: rash, rash erythematous, rash follicular, rash macular, rash papular, rash pustular, rash vesicular, genital rash, intermittent leg rash, rash on scrotum and penis, rash maculo-papular, rash pruritic, contact dermatitis, dermatitis acneiform

⁵ Includes the following terms: hypertension, blood pressure increased, hypertensive crisis, blood pressure fluctuation

Other clinically important adverse reactions (all grades) that were reported in <10% of patients treated with CABOMETYX included: wound complications (2%), convulsion (<1%), pancreatitis (<1%), osteonecrosis of the jaw (<1%), and hepatitis cholestatic (<1%).

Table 2. Laboratory Abnormalities Occurring in ≥ 25% Patients Who Received CABOMETYX in METEOR

Laboratory Abnormality	CABOMETYX (n=331)		Everolimus (n=322)	
	All Grades	Grade 3-4	All Grades	Grade 3-4
	Percentage (%) of Patients			
Chemistry				
Increased AST	74	3	40	<1
Increased ALT	68	3	32	<1
Increased creatinine	58	<1	71	0
Increased triglycerides	53	4	73	13
Hypophosphatemia	48	8	36	5
Hyperglycemia	37	2	59	8
Hypoalbuminemia	36	2	28	<1
Increased ALP	35	2	29	1
Hypomagnesemia	31	7	4	<1
Hyponatremia	30	8	26	6
Increased GGT	27	5	43	9
Hematology				
Leukopenia	35	<1	31	<1
Neutropenia	31	2	17	<1
Anemia ¹	31	4	71	17
Lymphopenia	25	7	39	12
Thrombocytopenia	25	<1	27	<1
ALP, alkaline phosphatase; ALT, alanine aminotransferase; AST, aspartate aminotransferase; GGT, gamma glutamyl transferase. NCI CTCAE, Version 4.0 ¹ Based on laboratory abnormalities				

CABOSUN

The safety of CABOMETYX was evaluated in CABOSUN, a randomized, open-label trial in patients with advanced renal cell carcinoma, in which 78 patients received CABOMETYX 60 mg once daily and 72 patients received sunitinib 50 mg once daily (4 weeks on treatment followed by 2 weeks off), until disease progression or unacceptable toxicity [see *Clinical Studies (14.1)*]. The median duration of treatment was 6.5 months (range 0.2 – 28.7) for patients receiving CABOMETYX and 3.1 months (range 0.2 – 25.5) for patients receiving sunitinib.

Within 30 days of treatment, there were 4 deaths in patients treated with CABOMETYX and 6 deaths in patients treated with sunitinib. Of the 4 patients treated with CABOMETYX, 2 patients died due to gastrointestinal perforation, 1 patient had acute renal failure, and 1 patient died due to clinical deterioration. All Grade 3-4 adverse reactions were collected in the entire safety population. The most frequent Grade 3-4 adverse reactions (≥5%) in patients treated with

CABOMETYX were hypertension, diarrhea, hyponatremia, hypophosphatemia, PPE, fatigue, increased ALT, decreased appetite, stomatitis, pain, hypotension, and syncope.

The median average daily dose was 50.3 mg for CABOMETYX and 44.7 mg for sunitinib (excluding scheduled sunitinib non-dosing days). The dose was reduced in 46% of patients receiving CABOMETYX and in 35% of patients receiving sunitinib. The dose was held in 73% of patients receiving CABOMETYX and in 71% of patients receiving sunitinib. Based on patient disposition, 21% of patients receiving CABOMETYX and 22% of patients receiving sunitinib discontinued due to an adverse reaction.

Table 3. Grade 3-4 Adverse Reactions Occurring in \geq 1% Patients Who Received CABOMETYX in CABOSUN

Adverse Reaction	CABOMETYX (n = 78)	Sunitinib (n = 72)
	Grade 3-4 ¹	Grade 3-4 ¹
	Percentage (%) of Patients	
Patients with any Grade 3-4 Adverse Reaction	68	65
Gastrointestinal		
Diarrhea	10	11
Stomatitis	5	6
Nausea	3	4
Vomiting	1	3
Constipation	1	0
General		
Fatigue	6	17
Pain	5	0
Metabolism and Nutrition		
Hyponatremia ²	9	8
Hypophosphatemia ²	9	7
Decreased appetite	5	1
Dehydration	4	1
Hypocalcemia ²	3	0
Hypomagnesemia ²	3	0
Hyperkalemia ²	1	3
Skin and Subcutaneous Tissue		
Palmar-plantar erythrodysesthesia	8	4
Skin ulcer	3	0
Vascular		
Hypertension ³	28	21
Hypotension	5	1
Angiopathy	1	1
Investigations		
Increased ALT ²	5	0
Weight decreased	4	0
Increased AST ²	3	3
Increased blood creatinine ²	3	3
Lymphopenia ²	1	6

Adverse Reaction	CABOMETYX (n = 78)	Sunitinib (n = 72)
	Grade 3-4 ¹	Grade 3-4 ¹
	Percentage (%) of Patients	
Thrombocytopenia ²	1	11
Nervous System		
Syncope	5	0
Respiratory, Thoracic, and Mediastinal		
Dyspnea	1	6
Dysphonia	1	0
Blood and Lymphatic		
Anemia	1	3
Psychiatric		
Depression	4	0
Confusional state	1	1
Infections		
Lung infection	4	0
Musculoskeletal and Connective Tissue		
Back pain	4	0
Bone pain	3	1
Pain in extremity	3	0
Arthralgia	1	0
Renal and Urinary		
Renal failure acute	4	1
Proteinuria	3	1

ALT, alanine aminotransferase; AST, aspartate aminotransferase
¹ NCI CTCAE Version 4.0
² Laboratory abnormalities are reported as adverse reactions and not based on shifts in laboratory values
³ Includes the following term: hypertension

Hepatocellular Carcinoma

The safety of CABOMETYX was evaluated in CELESTIAL, a randomized, double-blind, placebo-controlled trial in which 704 patients with advanced hepatocellular carcinoma were randomized to receive CABOMETYX 60 mg orally once daily (n=467) or placebo (n=237) until disease progression or unacceptable toxicity [see *Clinical Studies (14.2)*]. The median duration of treatment was 3.8 months (range 0.1 – 37.3) for patients receiving CABOMETYX and 2.0 months (range 0.0 – 27.2) for patients receiving placebo. The population exposed to CABOMETYX was 81% male, 56% White, and had a median age of 64 years.

Adverse reactions occurring in $\geq 25\%$ of CABOMETYX-treated patients, in order of decreasing frequency were: diarrhea, decreased appetite, PPE, fatigue, nausea, hypertension, and vomiting. Grade 3-4 adverse reactions which occurred in $\geq 5\%$ of patients were PPE, hypertension, fatigue, diarrhea, asthenia, and decreased appetite. There were 6 adverse reactions leading to death in patients receiving CABOMETYX (hepatic failure, hepatorenal syndrome, esophagobronchial fistula, portal vein thrombosis, pulmonary embolism, upper gastrointestinal hemorrhage).

The median average daily dose was 35.8 mg for CABOMETYX. The dose was reduced in 62% of patients receiving CABOMETYX; 33% of patients required a reduction to 20 mg daily. The most frequent adverse reactions or laboratory abnormalities leading to dose reduction of CABOMETYX were: PPE, diarrhea, fatigue, hypertension, and increased AST. Adverse reactions leading to dose interruption occurred in 84% patients receiving CABOMETYX. Adverse reactions leading to permanent discontinuation of CABOMETYX occurred in 16% of patients. The most frequent adverse reactions leading to permanent discontinuation of CABOMETYX were PPE (2%), fatigue (2%), decreased appetite (1%), diarrhea (1%), and nausea (1%).

Table 4. Adverse Reactions Occurring in $\geq 5\%$ of CABOMETYX-Treated Patients in CELESTIAL¹

Adverse Reaction	CABOMETYX (n = 467)		Placebo (n = 237)	
	All Grades ²	Grade 3-4	All Grades ²	Grade 3-4
	Percentage (%) of Patients			
Gastrointestinal				
Diarrhea	54	10	19	2
Nausea	31	2	18	2
Vomiting	26	<1	12	3
Stomatitis	13	2	2	0
Dyspepsia	10	0	3	0
General				
Fatigue	45	10	30	4
Asthenia	22	7	8	2
Mucosal inflammation	14	2	2	<1
Metabolism and Nutrition				
Decreased appetite	48	6	18	<1
Skin and Subcutaneous Tissue				
Palmar-plantar erythrodysesthesia	46	17	5	0
Rash ³	21	2	9	<1
Vascular				
Hypertension ⁴	30	16	6	2
Investigations				
Weight decreased	17	1	6	0
Nervous System				
Dysgeusia	12	0	2	0
Endocrine				
Hypothyroidism	8	<1	<1	0
Respiratory, Thoracic, and Mediastinal				
Dysphonia	19	1	2	0
Dyspnea	12	3	10	<1
Musculoskeletal and Connective Tissue				
Pain in extremity	9	<1	4	1
Muscle spasms	8	<1	2	0

Adverse Reaction	CABOMETYX (n = 467)		Placebo (n = 237)	
	All Grades ²	Grade 3-4	All Grades ²	Grade 3-4
¹ Includes terms with a between-arm difference of $\geq 5\%$ (all grades) or $\geq 2\%$ (Grade 3-4)				
² NCI CTCAE Version 4.0				
³ Includes the following terms: rash, rash erythematous, rash generalized, rash macular, rash maculopapular, rash papular, rash pruritic, rash pustular, rash vesicular, dermatitis, dermatitis acneiform, dermatitis contact, dermatitis diaper, dermatitis exfoliative, dermatitis infected				
⁴ Includes the following terms: hypertension, blood pressure diastolic increased, blood pressure increased				

Table 5. Laboratory Abnormalities Occurring in $\geq 5\%$ of CABOMETYX-Treated Patients in CELESTIAL¹

Laboratory Abnormality	CABOMETYX N=467		Placebo N=237	
	All Grades	Grade 3-4	All Grades	Grade 3-4
Percentage of Patients				
Chemistry				
Increased LDH	84	9	29	2
Increased ALT	73	12	37	6
Increased AST	73	24	46	19
Hypoalbuminemia	51	1	32	1
Increased ALP	43	8	38	6
Hypophosphatemia	25	9	8	4
Hypokalemia	23	6	6	1
Hypomagnesemia	22	3	3	0
Increased amylase	16	2	9	2
Hypocalcemia	8	2	0	0
Hematology				
Decreased platelets	54	10	16	1
Neutropenia	43	7	8	1
Increased hemoglobin	8	0	1	0
¹ Includes laboratory abnormalities with a between-arm difference of $\geq 5\%$ (all grades) or $\geq 2\%$ (Grade 3-4) ALP, alkaline phosphatase; ALT, alanine aminotransferase; AST, aspartate aminotransferase; LDH, blood lactate dehydrogenase				

6.2 Postmarketing Experience

The following adverse reactions have been identified during postapproval use of CABOMETYX. Because these reactions are reported voluntarily from a population of uncertain size, it is not always possible to reliably estimate their frequency or establish a causal relationship to drug exposure.

Vascular Disorders: Arterial (including aortic) aneurysms, dissections, and rupture

7 DRUG INTERACTIONS

7.1 Effects of Other Drugs on CABOMETYX

Strong CYP3A4 Inhibitors

Coadministration of a cabozantinib capsule formulation with a strong CYP3A4 inhibitor increased the exposure of cabozantinib, which may increase the risk of exposure-related adverse reactions [see *Clinical Pharmacology (12.3)*]. Avoid coadministration of CABOMETYX with strong CYP3A4 inhibitors. Reduce the dosage of CABOMETYX if coadministration with strong CYP3A4 inhibitors cannot be avoided [see *Dosage and Administration (2.5)*]. Avoid grapefruit or grapefruit juice which may also increase exposure of cabozantinib.

Strong CYP3A Inducers

Coadministration of a cabozantinib capsule formulation with a strong CYP3A4 inducer decreased the exposure of cabozantinib, which may reduce efficacy [see *Clinical Pharmacology (12.3)*]. Avoid coadministration of CABOMETYX with strong CYP3A4 inducers. Increase the dosage of CABOMETYX if coadministration with strong CYP3A4 inducers cannot be avoided [see *Dosage and Administration (2.6)*]. Avoid St. John's wort which may also decrease exposure of cabozantinib.

8 USE IN SPECIFIC POPULATIONS

8.1 Pregnancy

Risk Summary

Based on findings from animal studies and its mechanism of action [see *Clinical Pharmacology (12.1)*], CABOMETYX can cause fetal harm when administered to a pregnant woman. There are no available data in pregnant women to inform the drug-associated risk. In animal developmental and reproductive toxicology studies administration of cabozantinib to pregnant rats and rabbits during organogenesis resulted in embryofetal lethality and structural anomalies at exposures that were below those occurring clinically at the recommended dose (see *Data*). Advise pregnant women of the potential risk to a fetus.

In the U.S. general population, the estimated background risk of major birth defects and miscarriage in clinically recognized pregnancies is 2-4% and 15-20%, respectively.

Data

Animal Data

In an embryo-fetal development study in pregnant rats, daily oral administration of cabozantinib throughout organogenesis caused increased embryo-fetal lethality compared to controls at a dose of 0.03 mg/kg (approximately 0.12-fold of human area under the curve [AUC] at the recommended dose). Findings included delayed ossification and skeletal variations at a dose of 0.01 mg/kg/day (approximately 0.04-fold of human AUC at the recommended dose).

In pregnant rabbits, daily oral administration of cabozantinib throughout organogenesis resulted in findings of visceral malformations and variations including reduced spleen size and missing lung lobe at 3 mg/kg (approximately 1.1-fold of the human AUC at the recommended dose).

In a pre- and postnatal study in rats, cabozantinib was administered orally from gestation day 10 through postnatal day 20. Cabozantinib did not produce adverse maternal toxicity or affect pregnancy, parturition or lactation of female rats, and did not affect the survival, growth or postnatal development of the offspring at doses up to 0.3 mg/kg/day (0.05-fold of the maximum recommended clinical dose).

8.2 Lactation

Risk Summary

There is no information regarding the presence of cabozantinib or its metabolites in human milk, or their effects on the breastfed child or milk production. Because of the potential for serious adverse reactions in breastfed children, advise women not to breastfeed during treatment with CABOMETYX and for 4 months after the final dose.

8.3 Females and Males of Reproductive Potential

Pregnancy Testing

Verify the pregnancy status of females of reproductive potential prior to initiating CABOMETYX [see *Use in Specific Populations (8.1)*].

Contraception

CABOMETYX can cause fetal harm when administered to a pregnant woman [see *Use in Specific Populations (8.1)*].

Females

Advise females of reproductive potential to use effective contraception during treatment with CABOMETYX and for 4 months after the final dose.

Infertility

Females and Males

Based on findings in animals, CABOMETYX may impair fertility in females and males of reproductive potential [see *Nonclinical Toxicology (13.1)*].

8.4 Pediatric Use

The safety and effectiveness of CABOMETYX in pediatric patients have not been established.

Juvenile Animal Toxicity Data

Juvenile rats were administered cabozantinib at doses of 1 or 2 mg/kg/day from Postnatal Day 12 (comparable to less than 2 years in humans) through Postnatal Day 35 or 70. Mortalities occurred at doses ≥ 1 mg/kg/day (approximately 0.16 times the clinical dose of 60 mg/day based on body surface area). Hypoactivity was observed at both doses tested on Postnatal Day 22. Targets were generally similar to those seen in adult animals, occurred at both doses, and included the kidney

(nephropathy, glomerulonephritis), reproductive organs, gastrointestinal tract (cystic dilatation and hyperplasia in Brunner's gland and inflammation of duodenum; and epithelial hyperplasia of colon and cecum), bone marrow (hypocellularity and lymphoid depletion), and liver. Tooth abnormalities and whitening as well as effects on bones including reduced bone mineral content and density, physal hypertrophy, and decreased cortical bone also occurred at all dose levels. Recovery was not assessed at a dose of 2 mg/kg (approximately 0.32 times the clinical dose of 60 mg based on body surface area) due to high levels of mortality. At the low dose level, effects on bone parameters were partially resolved but effects on the kidney and epididymis/testis persisted after treatment ceased.

8.5 Geriatric Use

In CABOSUN and METEOR, 41% of 409 patients treated with CABOMETYX were age 65 years and older, and 8% were 75 years and older. In CELESTIAL, 49% of 467 patients treated with CABOMETYX were age 65 years and older, and 15% were 75 years and older.

No overall differences in safety or effectiveness were observed between these patients and younger patients.

8.6 Hepatic Impairment

Increased exposure to cabozantinib has been observed in patients with moderate (Child-Pugh B) hepatic impairment. Reduce the CABOMETYX dose in patients with moderate hepatic impairment. Avoid CABOMETYX in patients with severe hepatic impairment (Child-Pugh C), since it has not been studied in this population [see *Dosage and Administration (2.7)*, *Clinical Pharmacology (12.3)*].

8.7 Renal Impairment

No dosage adjustment is recommended in patients with mild or moderate renal impairment. There is no experience with CABOMETYX in patients with severe renal impairment [see *Clinical Pharmacology (12.3)*].

10 OVERDOSAGE

One case of overdosage was reported following administration of another formulation of cabozantinib; a patient inadvertently took twice the intended dose for 9 days. The patient suffered Grade 3 memory impairment, Grade 3 mental status changes, Grade 3 cognitive disturbance, Grade 2 weight loss, and Grade 1 increase in BUN. The extent of recovery was not documented.

11 DESCRIPTION

CABOMETYX is the (*S*)-malate salt of cabozantinib, a kinase inhibitor. Cabozantinib (*S*)-malate is described chemically as *N*-(4-(6,7-dimethoxyquinolin-4-yloxy)phenyl)-*N'*-(4-fluorophenyl)cyclopropane-1,1-dicarboxamide, (2*S*)-hydroxybutanedioate. The molecular

formula is $C_{28}H_{24}FN_3O_5 \cdot C_4H_6O_5$ and the molecular weight is 635.6 Daltons as malate salt. The chemical structure of cabozantinib (*S*)-malate salt is:

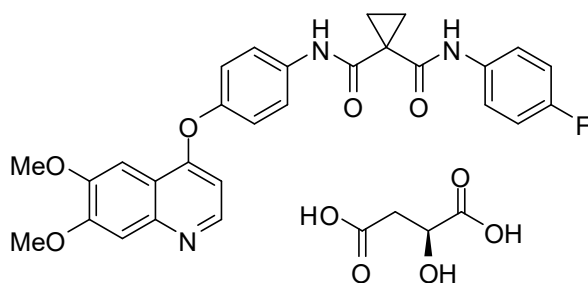

Cabozantinib (*S*)-malate salt is a white to off-white solid that is practically insoluble in aqueous media.

CABOMETYX (cabozantinib) tablets for oral use are supplied as film-coated tablets containing 20 mg, 40 mg, or 60 mg of cabozantinib, which is equivalent to 25 mg, 51 mg, or 76 mg of cabozantinib (*S*)-malate, respectively. CABOMETYX also contains the following inactive ingredients: microcrystalline cellulose, lactose anhydrous, hydroxypropyl cellulose, croscarmellose sodium, colloidal silicon dioxide, and magnesium stearate.

The film coating contains hypromellose, titanium dioxide, triacetin, and iron oxide yellow.

12 CLINICAL PHARMACOLOGY

12.1 Mechanism of Action

In vitro biochemical and/or cellular assays have shown that cabozantinib inhibits the tyrosine kinase activity of MET, VEGFR-1, -2 and -3, AXL, RET, ROS1, TYRO3, MER, KIT, TRKB, FLT-3, and TIE-2. These receptor tyrosine kinases are involved in both normal cellular function and pathologic processes such as oncogenesis, metastasis, tumor angiogenesis, drug resistance, and maintenance of the tumor microenvironment.

12.2 Pharmacodynamics

The exposure-response or –safety relationship for cabozantinib is unknown.

Cardiac Electrophysiology

The effect of cabozantinib on QTc interval was evaluated in a randomized, double-blinded, placebo-controlled trial in patients with medullary thyroid cancer administered a cabozantinib capsule formulation. A mean increase in QTcF of 10 - 15 ms was observed at 4 weeks after initiation. A concentration-QTc relationship could not be definitively established. Changes in cardiac wave form morphology or new rhythms were not observed. No patients in this study had a confirmed QTcF > 500 ms nor did any patients in METEOR, CABOSUN, or CELESTIAL.

12.3 Pharmacokinetics

Repeat daily dosing of a cabozantinib capsule formulation for 19 days resulted in 4- to 5-fold mean cabozantinib accumulation (based on AUC) compared to a single dose administration; steady state was achieved by Day 15.

Absorption

Median time to peak cabozantinib concentrations (T_{max}) ranged from 3 to 4 hours post-dose. A 19% increase in the C_{max} of CABOMETYX compared to a cabozantinib capsule formulation was observed following a single 140 mg dose. A less than 10% difference in the AUC was observed between CABOMETYX and a cabozantinib capsule formulation [see *Dosage and Administration (2.1)*].

Food Effect

Cabozantinib C_{max} and AUC increased by 41% and 57%, respectively, following a high-fat meal relative to fasted conditions in healthy subjects administered a single oral dose of a cabozantinib capsule formulation.

Distribution

The oral volume of distribution (V_z/F) of cabozantinib is approximately 319 L. Cabozantinib is highly protein bound in human plasma ($\geq 99.7\%$).

Elimination

The predicted terminal half-life is approximately 99 hours and the clearance (CL/F) at steady-state is estimated to be 2.2 L/hr.

Metabolism

Cabozantinib is a substrate of CYP3A4 in vitro.

Excretion

Approximately 81% of the total administered radioactivity was recovered within a 48-day collection period following a single dose of radiolabeled ^{14}C -cabozantinib in healthy subjects. Approximately 54% was recovered in feces and 27% in urine. Unchanged cabozantinib accounted for 43% of the total radioactivity in feces and was not detectable in urine following a 72-hour collection.

Specific Populations

The following patient characteristics did not result in a clinically relevant difference in the pharmacokinetics of cabozantinib: age (32-86 years), sex, race (Whites and non-Whites), or mild to moderate renal impairment ($eGFR \geq 30$ mL/min/1.73 m² as estimated by MDRD (modification of diet in renal disease equation)). The pharmacokinetics of cabozantinib is unknown in patients with $eGFR < 29$ mL/min/1.73m² as estimated by MDRD equation or requiring dialysis.

Patients with Hepatic Impairment

Based on a population pharmacokinetic analysis of cabozantinib in healthy subjects and patients with cancer, no clinically significant differences in the mean cabozantinib exposure were

observed between subjects with normal liver function (total bilirubin and AST \leq ULN) and those with mild hepatic impairment (total bilirubin \leq ULN and AST $>$ ULN or total bilirubin $>$ 1 to 1.5x ULN and any AST value). In a dedicated pharmacokinetic study, cabozantinib exposure (AUC_{0-12h}) increased by 63% in patients with moderate hepatic impairment (Child-Pugh B). Patients with severe hepatic impairment have not been studied [see [Dosage and Administration \(2.7\)](#), [Use in Specific Populations \(8.6\)](#)].

Drug Interaction Studies

Clinical Studies

CYP3A4 Inhibitors:

Administration of a strong CYP3A4 inhibitor, ketoconazole (400 mg daily for 27 days), with a cabozantinib capsule formulation to healthy subjects increased single-dose cabozantinib exposure (AUC_{0-12h}) by 38%.

CYP3A4 Inducers:

Administration of a strong CYP3A4 inducer, rifampin (600 mg daily for 31 days), with a cabozantinib capsule formulation to healthy subjects decreased single-dose cabozantinib exposure (AUC_{0-12h}) by 77%.

CYP2C8 Substrates:

No clinically-significant effect on single-dose rosiglitazone (a CYP2C8 substrate) exposure (C_{max} and AUC) was observed when co-administered with a cabozantinib capsule formulation at steady-state concentrations.

Gastric Acid Reducing Agents:

No clinically-significant effect on cabozantinib exposure (AUC) was observed following co-administration of the proton pump inhibitor (PPI) esomeprazole (40 mg daily for 6 days) with a single 100 mg dose of a cabozantinib capsule formulation to healthy subjects.

In vitro Studies

CYP Enzymes:

Inhibition of CYP3A4 reduced the formation of the oxidative metabolite by $>$ 80%. Inhibition of CYP2C9 had a minimal effect on cabozantinib metabolite formation (i.e., a $<$ 20% reduction). Inhibition of CYP1A2, CYP2A6, CYP2B6, CYP2C8, CYP2C19, CYP2D6 and CYP2E1 had no effect on cabozantinib metabolite formation.

Although cabozantinib is an inhibitor of CYP2C8 in vitro, a clinical study of this potential interaction concluded that concurrent use did not result in a clinically relevant effect on CYP2C8 substrate exposure. Given this finding, other less sensitive substrates of pathways affected by cabozantinib in vitro (i.e., CYP2C9, CYP2C19, and CYP3A4) were not evaluated in a clinical study, because, although a clinically relevant exposure effect cannot be ruled out, it is unlikely. Cabozantinib does not inhibit CYP1A2 and CYP2D6 isozymes in vitro.

Cabozantinib is an inducer of CYP1A1 mRNA; however, the clinical relevance of this finding is unknown. Cabozantinib does not induce CYP1A2, CYP2B6, CYP2C8, CYP2C9, CYP2C19 or CYP3A4.

Transporters:

Cabozantinib is an inhibitor, but not a substrate, of P-gp transport activities and has the potential to increase concentrations of co-administered substrates of P-gp. The clinical relevance of this finding is unknown.

Cabozantinib is a substrate of MRP2 in vitro and MRP2 inhibitors have the potential to increase concentrations of cabozantinib. The clinical relevance of this finding is unknown.

13 NONCLINICAL TOXICOLOGY

13.1 Carcinogenesis, Mutagenesis, Impairment of Fertility

The carcinogenic potential of cabozantinib has been evaluated in two species: rasH2 transgenic mice and Sprague-Dawley rats. In the 2-year rat carcinogenicity study, once daily oral administration of cabozantinib resulted in a statistically significant increase in the incidence of malignant/complex malignant pheochromocytoma in combination with benign pheochromocytoma or in benign pheochromocytoma alone in male rats at a dose of 1 mg/kg (approximately 5 times the human exposure by AUC at the recommended 60 mg dose). Cabozantinib was not carcinogenic in a 26-week carcinogenicity study in rasH2 transgenic mice at a slightly higher exposure than the intended human therapeutic exposure.

Cabozantinib was not mutagenic in vitro in the bacterial reverse mutation (Ames) assay and was not clastogenic in both the in vitro cytogenetic assay using human lymphocytes or in the *in vivo* mouse micronucleus assay.

Based on nonclinical findings, male and female fertility may be impaired by treatment with CABOMETYX. In a fertility study in which cabozantinib was administered to male and female rats at doses of 1, 2.5, and 5 mg/kg/day, male fertility was significantly compromised at doses equal to or greater than 2.5 mg/kg/day (approximately 13-fold of human AUC at the recommended dose), with a decrease in sperm counts and reproductive organ weights. In females, fertility was significantly reduced at doses equal to or greater than 1 mg/kg/day (5-fold of human AUC at the recommended dose) with a significant decrease in the number of live embryos and a significant increase in pre- and post-implantation losses.

Observations of effects on reproductive tract tissues in general toxicology studies were supportive of effects noted in the dedicated fertility study and included hypospermia and absence of corpora lutea in male and female dogs in a 6-month repeat dose study at plasma exposures (AUC) approximately 0.5-fold (males) and <0.1-fold (females) of those expected in humans at the recommended dose. In addition, female rats administered 5 mg/kg/day for 14 days (approximately 9-fold of human AUC at the recommended dose) exhibited ovarian necrosis.

14 CLINICAL STUDIES

14.1 Renal Cell Carcinoma

Previously Treated with Anti-angiogenic Therapy

The efficacy of CABOMETYX was evaluated in METEOR (NCT01865747), a randomized (1:1), open-label, multicenter trial of CABOMETYX versus everolimus conducted in patients with advanced RCC who had received at least 1 prior anti-angiogenic therapy. Patients had to have a Karnofsky Performance Score (KPS) \geq 70%. Patients were stratified by the number of prior VEGFR tyrosine kinase inhibitors (TKIs) and Memorial Sloan Kettering Cancer Center (MSKCC) Risk Group.

Patients were randomized to receive CABOMETYX (N=330) 60 mg orally once daily or everolimus (N=328) 10 mg orally once daily. The majority of the patients were male (75%), with a median age of 62 years. Sixty-nine percent (69%) received only one prior anti-angiogenic therapy. Patient distribution by MSKCC risk groups was 46% favorable (0 risk factors), 42% intermediate (1 risk factor), and 13% poor (2 or 3 risk factors). Fifty-four percent (54%) of patients had 3 or more organs with metastatic disease, including lung (63%), lymph nodes (62%), liver (29%), and bone (22%).

The main efficacy outcome measure was progression-free survival (PFS) assessed by a blinded independent radiology review committee among the first 375 subjects randomized. Other efficacy endpoints were objective response rate (ORR) and overall survival (OS) in the Intent-to-Treat (ITT) population. Tumor assessments were conducted every 8 weeks for the first 12 months, then every 12 weeks thereafter. Patients received treatment until disease progression or experiencing unacceptable toxicity. Patients on both arms who had disease progression could continue treatment at the discretion of the investigator.

Statistically significant improvements in PFS, OS, and ORR were demonstrated for CABOMETYX compared to everolimus. Efficacy results are presented in Tables 6 and 7 and Figures 1 and 2.

Table 6: Efficacy Results in METEOR (First 375 Randomized)

Endpoint	CABOMETYX	Everolimus
	N = 187	N = 188
Median PFS (95% CI), months	7.4 (5.6, 9.1)	3.8 (3.7, 5.4)
HR (95% CI), p-value ¹	0.58 (0.45, 0.74), p<0.0001	

¹ stratified log-rank test with prior VEGFR-targeting TKI therapy (1 vs 2 or more) and MSKCC prognostic criteria for previously treated patients with RCC (0 vs 1 vs 2 or 3) as stratification factors (per IVRS data)

Figure 1: Kaplan-Meier Curves of Progression-Free Survival in METEOR (First 375 Randomized)

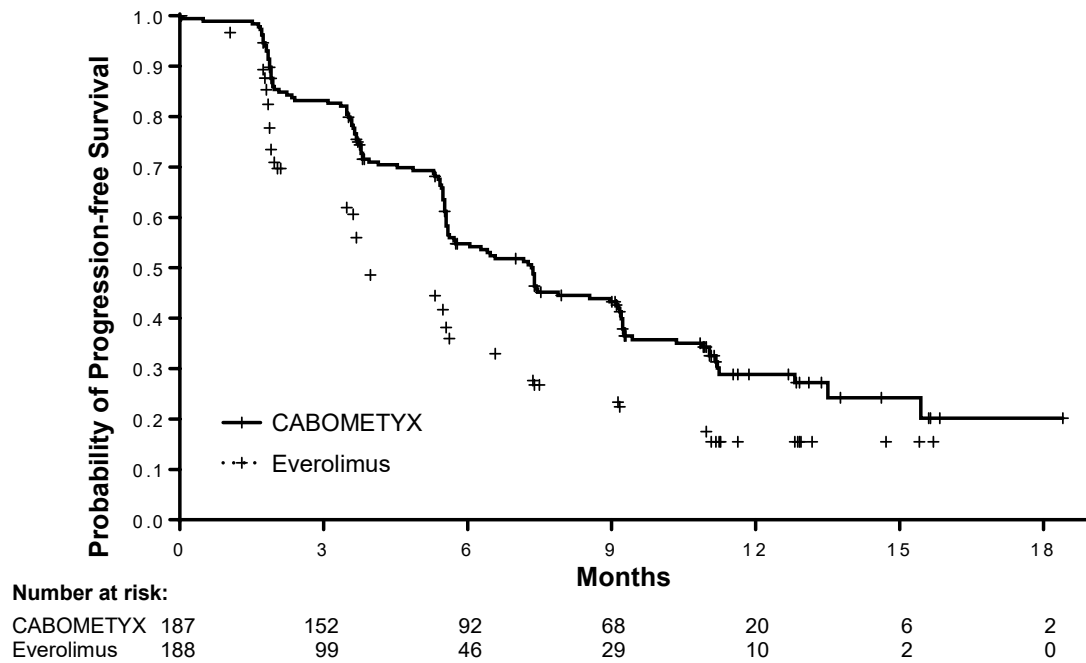

Table 7: Efficacy Results in METEOR (ITT)

Endpoint	CABOMETYX	Everolimus
	N = 330	N = 328
Median OS (95% CI), months	21.4 (18.7, NE)	16.5 (14.7, 18.8)
HR (95% CI), p-value ¹	0.66 (0.53, 0.83), p=0.0003	
Confirmed ORR (partial responses only) (95% CI)	17% (13%, 22%)	3% (2%, 6%)
p-value ²	p<0.0001	

¹ stratified log-rank test with prior VEGFR-targeting TKI therapy (1 vs 2 or more) and MSKCC prognostic criteria for previously treated patients with RCC (0 vs 1 vs 2 or 3) as stratification factors (per IVRS data)

² chi-squared test

Figure 2: Kaplan-Meier Curve of Overall Survival in METEOR (ITT)

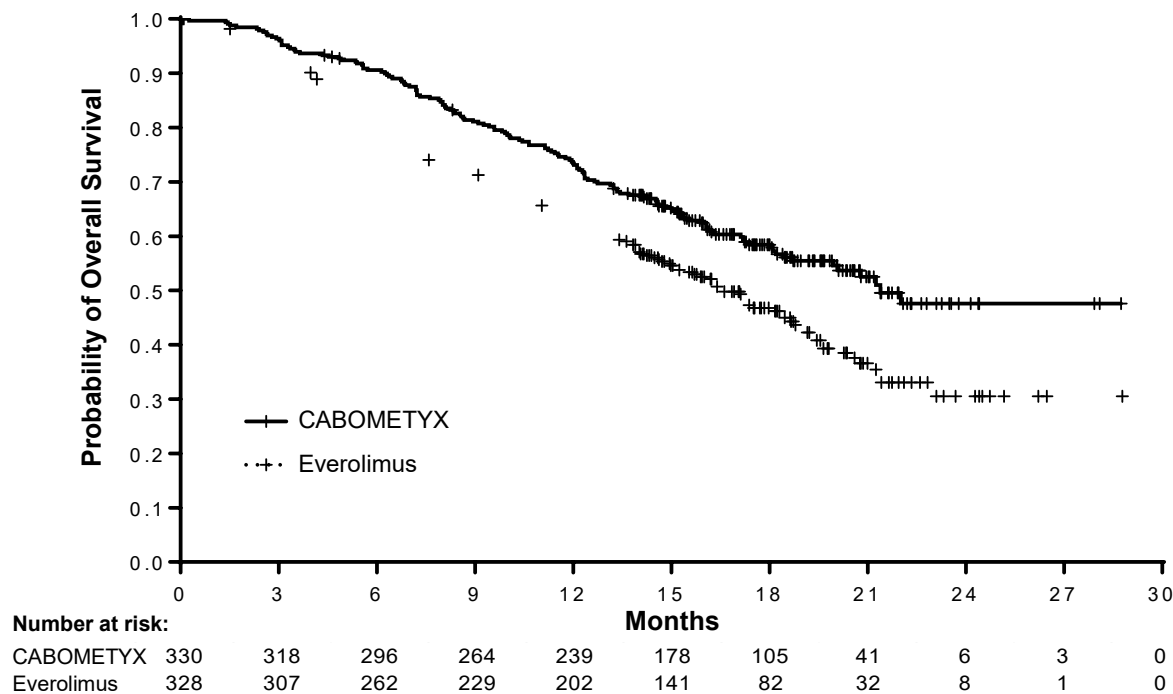

First-line Treatment

The efficacy of CABOMETYX was evaluated in CABOSUN (NCT01835158), a randomized (1:1), open-label, multicenter trial of CABOMETYX versus sunitinib conducted in patients with advanced RCC who had not received prior therapy. Patients were randomized to receive CABOMETYX (N=79) 60 mg orally once daily or sunitinib (N=78) 50 mg orally once daily (4 weeks on treatment followed by 2 weeks off) until disease progression or unacceptable toxicity. All patients were required to have intermediate or poor risk disease as defined by the International Metastatic RCC Database Consortium (IMDC) risk group categories. Patients were stratified by IMDC risk group and presence of bone metastases (yes/no).

The majority of patients were male (78%), with a median age of 63 years. Patient distribution by IMDC risk groups was 81% intermediate (1-2 risk factors) and 19% poor (≥ 3 risk factors). Thirty-six percent (36%) patients had bone metastases. Forty-six percent (46%) of patients were ECOG 0, 41% ECOG 1, and 13% ECOG 2.

The major efficacy outcome measure was progression-free survival (PFS) by a retrospective blinded independent radiology review committee (BIRC).

A statistically significant improvement in PFS, as assessed by a blinded independent radiology review committee, was demonstrated for CABOMETYX compared to sunitinib. Efficacy results are presented in Table 8, Figure 3, and Figure 4.

Table 8: Efficacy Results in CABOSUN

Endpoint	CABOMETYX	Sunitinib
	N = 79	N = 78
Progression-Free Survival¹		
Events, n(%)	43 (54)	49 (63)
Median PFS (95% CI), months ¹	8.6 (6.8, 14.0)	5.3 (3.0, 8.2)
Hazard Ratio ² (95% CI), p-value ³	0.48 (0.31, 0.74), p=0.0008	
Overall Survival		
Events, n(%)	43 (54)	47 (60)
Hazard Ratio ^{2,4} (95% CI)	0.80 (0.53, 1.21)	
Confirmed ORR, partial responses only (95% CI)^{1,4}	20% (12.0, 30.8)	9% (3.7, 17.6)

¹ as assessed by a retrospective blinded independent radiology review committee (BIRC)

² estimated from stratified Cox proportional hazards model with stratification factors IMDC risk group and presence of bone metastases and treatment as covariate

³ two-sided stratified log-rank test with stratification factors IMDC risk group and presence of bone metastases

⁴ no multiplicity adjustments were made for overall survival or ORR

Figure 3: Kaplan-Meier Curve of Progression-Free Survival in CABOSUN

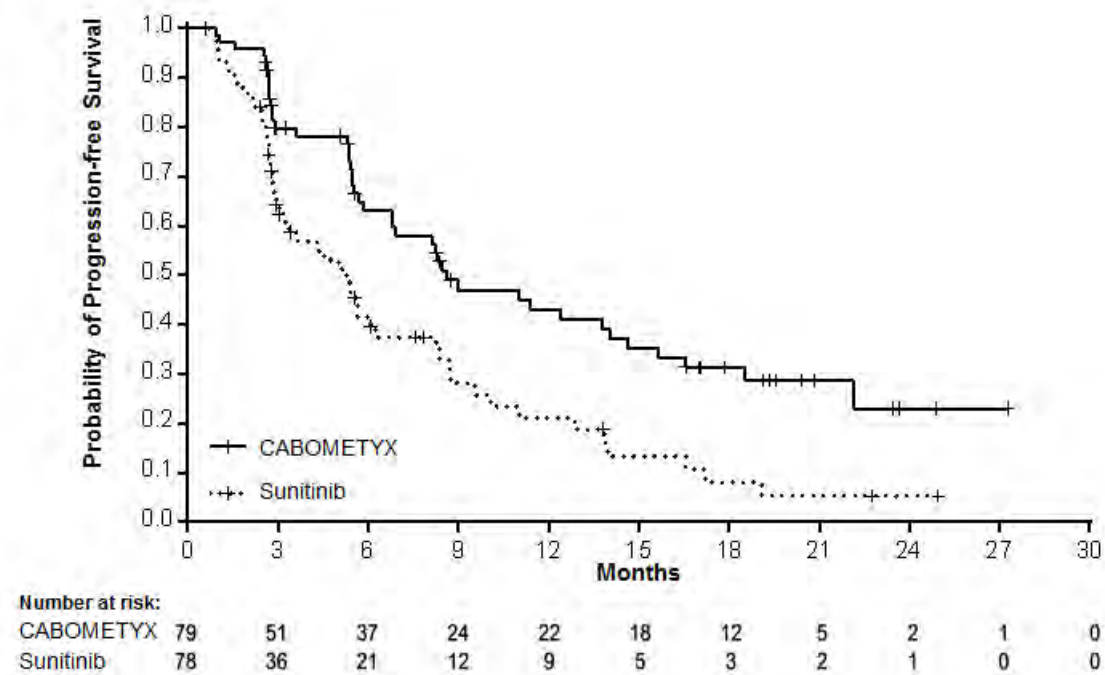
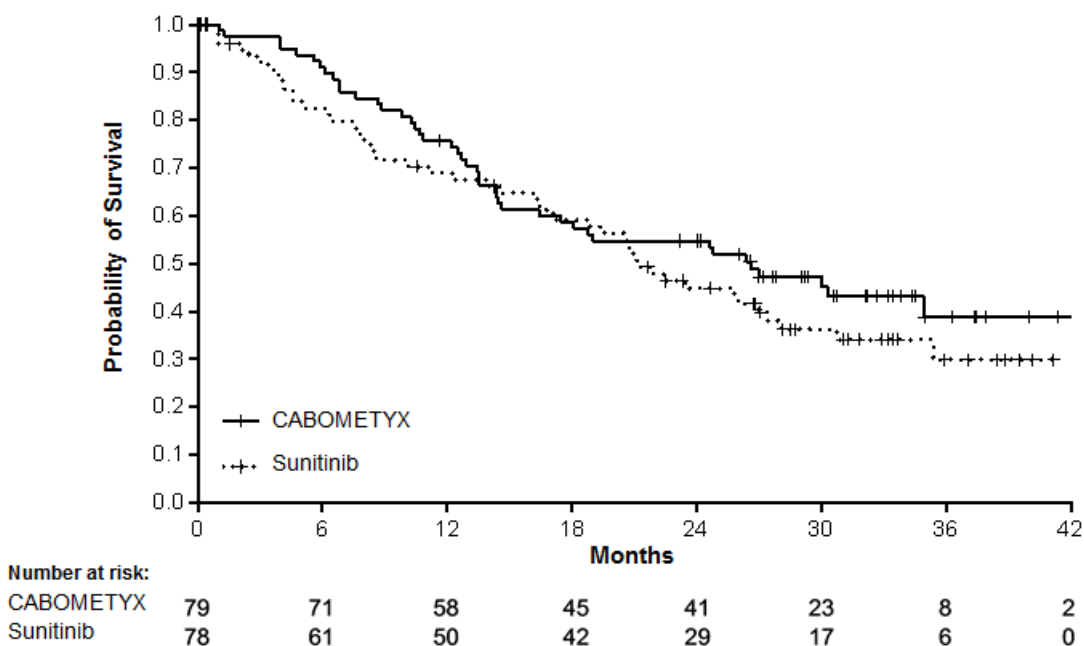

Figure 4: Kaplan-Meier Curve of Overall Survival in CABOSUN



14.2 Hepatocellular Carcinoma

The efficacy of CABOMETRYX was evaluated in CELESTIAL (NCT01908426), a randomized (2:1), double-blind, placebo-controlled, multicenter trial in patients with hepatocellular carcinoma (HCC) who had previously received sorafenib and had Child Pugh Class A liver impairment. Patients were randomized to receive CABOMETRYX 60 mg orally once daily or placebo until disease progression or unacceptable toxicity. Randomization was stratified by etiology of disease (hepatitis B virus [HBV] with or without hepatitis C virus [HCV] vs. HCV [without HBV] vs. other [without HBV and HCV]), geographic region (Asia vs. other regions), and presence of extrahepatic spread of disease and/or macrovascular invasion (yes vs. no). The primary efficacy outcome measure was overall survival (OS). Additional outcome measures were progression-free survival (PFS) and objective response rate (ORR), as assessed by investigators per RECIST 1.1. Tumor assessments were conducted every 8 weeks.

In CELESTIAL, a total of 707 patients were randomized, 470 to CABOMETRYX and 237 to placebo. The median age was 64 years (range 22 to 86 years), 82% were male, 56% were White and 34% were Asian. Baseline ECOG performance status was 0 (53%) or 1 (47%). The etiology of HCC was attributed to HBV in 38% of patients and HCV in 21%; etiology was attributed to causes other than HBV or HCV in 40%. Macroscopic vascular invasion or extra-hepatic tumor spread was present in 78% of patients and 41% had alpha-fetoprotein (AFP) levels ≥ 400 mcg/L. All patients received prior sorafenib and 27% received two prior systemic therapy regimens.

Efficacy results are summarized in Table 9, Figure 5, and Figure 6.

Table 9: Efficacy Results from CELESTIAL

Endpoint	CABOMETYX	Placebo
	N = 470	N = 237
Overall Survival		
Number of Deaths, (%)	317 (67)	167 (70)
Median OS in Months (95% CI)	10.2 (9.1, 12.0)	8.0 (6.8, 9.4)
Hazard Ratio (95% CI) ¹	0.76 (0.63, 0.92)	
p-value ²	p=0.0049 ³	
Progression-Free Survival		
Number of Events, (%)	349 (74)	205 (86)
Progressive Disease	284 (60)	186 (78)
Death	65 (14)	19 (8)
Median PFS in Months (95% CI)	5.2 (4.0, 5.5)	1.9 (1.9, 1.9)
Hazard Ratio (95% CI) ¹	0.44 (0.36, 0.52)	
p-value ²	p< 0.0001	
Overall Response Rate (ORR)		
Confirmed ORR (partial responses only) (95% CI) ³	4% (2.3, 6.0)	0.4% (0.0, 2.3)
p-value ⁴	p=0.0086	

CI, confidence interval

¹ estimated using the Cox proportional-hazard model

² log-rank test stratified by etiology of disease (HBV [with or without HCV], HCV [without HBV], or Other), geographic region (Asia, Other Regions), and presence of extrahepatic spread of disease and/or macrovascular invasion (Yes, No) as stratification factors (per IVRS data)

³ significance level = 0.021 for 78% information (484 deaths) based on O'Brien-Fleming method

⁴ Fisher's exact test

Figure 5: Kaplan-Meier Curve of Overall Survival in CELESTIAL

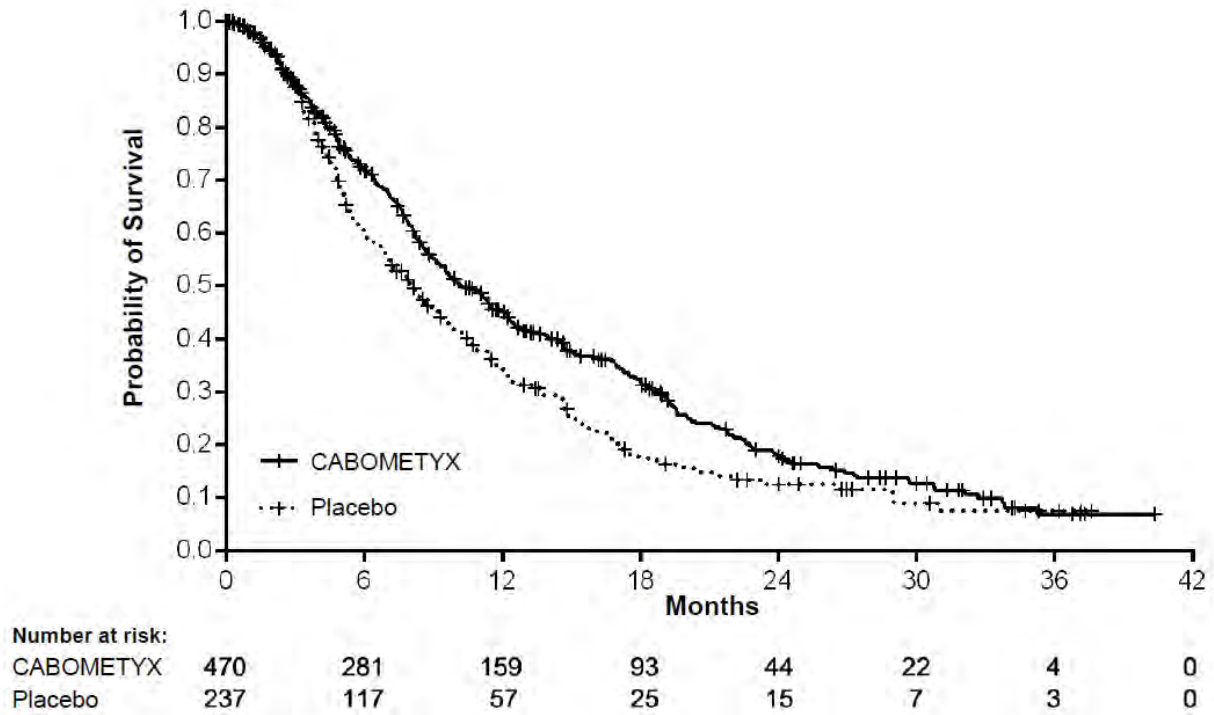
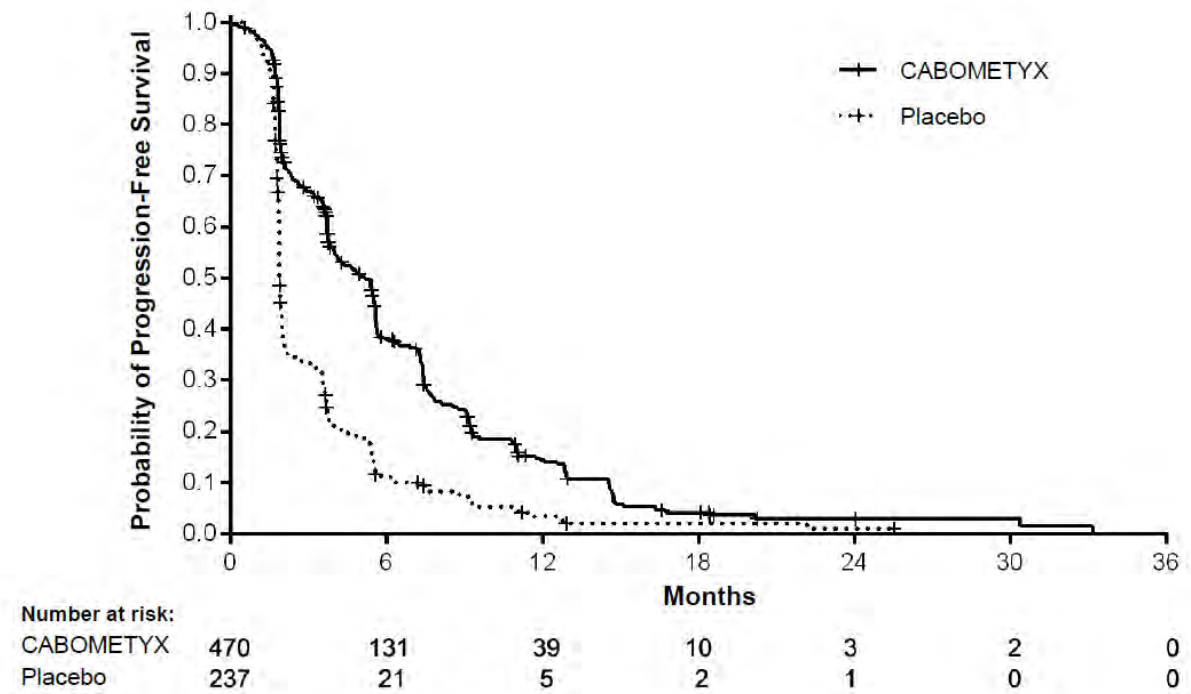

Figure 6: Kaplan-Meier Curve of Progression-Free Survival in CELESTIAL



16 HOW SUPPLIED/STORAGE AND HANDLING

CABOMETYX tablets are supplied as follows:

60 mg tablets are yellow film-coated, oval shaped with no score, debossed with “XL” on one side and “60” on the other side of the tablet; available in bottles of 30 tablets:

NDC 42388-023-26

40 mg tablets are yellow film-coated, triangle shaped with no score, debossed with “XL” on one side and “40” on the other side of the tablet; available in bottles of 30 tablets:

NDC 42388-025-26

20 mg tablets are yellow film-coated, round shaped with no score, debossed with “XL” on one side and “20” on the other side of the tablet; available in bottles of 30 tablets:

NDC 42388-024-26

Store CABOMETYX at 20°C to 25°C (68°F to 77°F); excursions are permitted from 15°C to 30°C (59°F to 86°F) [see USP Controlled Room Temperature].

17 PATIENT COUNSELING INFORMATION

Advise the patient to read the FDA-approved patient labeling (Patient Information).

- **Hemorrhage:** Instruct patients to contact their healthcare provider to seek immediate medical attention for signs or symptoms of unusual severe bleeding or hemorrhage [see *Warnings and Precautions (5.1)*].
- **Perforations and fistulas:** Advise patients that gastrointestinal disorders such as diarrhea, nausea, vomiting, and constipation may develop during CABOMETYX treatment and to seek immediate medical attention if they experience persistent or severe abdominal pain because cases of gastrointestinal perforation and fistula have been reported in patients taking CABOMETYX [see *Warnings and Precautions (5.2)*].
- **Thrombotic events:** Venous and arterial thrombotic events have been reported. Advise patients to report signs or symptoms of an arterial thrombosis. Venous thromboembolic events including pulmonary embolus have been reported. Advise patients to contact their health care provider if new onset of dyspnea, chest pain, or localized limb edema occurs [see *Warnings and Precautions (5.3)*].
- **Hypertension and hypertensive crisis:** Inform patients of the signs and symptoms of hypertension. Advise patients to undergo routine blood pressure monitoring and to contact their health care provider if blood pressure is elevated or if they experience signs or symptoms of hypertension [see *Warnings and Precautions (5.4)*].
- **Diarrhea:** Advise patients to notify their healthcare provider at the first signs of poorly formed or loose stool or an increased frequency of bowel movements [see *Warnings and Precautions (5.5)*].
- **Palmar-plantar erythrodysesthesia:** Advise patients to contact their healthcare provider for progressive or intolerable rash [see *Warnings and Precautions (5.6)*].

- Osteonecrosis of the jaw: Advise patients regarding good oral hygiene practices. Advise patients to immediately contact their healthcare provider for signs or symptoms associated with osteonecrosis of the jaw [see *Warnings and Precautions (5.8)*].
- Impaired wound healing: Advise patients that CABOMETYX may impair wound healing. Advise patients to inform their healthcare provider of any planned surgical procedure [see *Dosage and Administration (2.1), Warnings and Precautions (5.9)*].
- Reversible posterior leukoencephalopathy syndrome: Advise patients to immediately contact their health care provider for new onset or worsening neurological function [see *Warnings and Precautions (5.10)*].
- Embryo-fetal toxicity:
 - Advise females of reproductive potential of the potential risk to a fetus. Advise females to inform their healthcare provider of a known or suspected pregnancy [see *Warnings and Precautions (5.11), Use in Specific Populations (8.1)*].
 - Advise females of reproductive potential to use effective contraception during treatment with CABOMETYX and for 4 months after the final dose [see *Use in Specific Populations (8.3)*].
- Lactation: Advise women not to breastfeed during treatment with CABOMETYX and for 4 months following the last dose [see *Use in Specific Populations (8.2)*].
- Drug interactions: Advise patients to inform their healthcare provider of all prescription or nonprescription medications, vitamins or herbal products. Inform patients to avoid grapefruit, grapefruit juice, and St. John's wort [see *Drug Interactions (7.1)*].

Important administration information

- Instruct patients to take CABOMETYX at least 1 hour before or at least 2 hours after eating.

Manufactured for Exelixis, Inc. Alameda, CA 94502

PATIENT INFORMATION
CABOMETRYX® (Ka-boe-met-iks)
cabozantinib
tablets

What is CABOMETRYX?

CABOMETRYX is a prescription medicine used to treat people with:

- advanced kidney cancer (renal cell carcinoma)
- liver cancer (hepatocellular carcinoma) who have been previously treated with the medicine sorafenib.

It is not known if CABOMETRYX is safe and effective in children.

Before you take CABOMETRYX, tell your healthcare provider about all of your medical conditions, including if you:

- have a recent history of bleeding, including coughing up or vomiting blood, or black tarry stools.
- have an open or healing wound
- have high blood pressure
- plan to have any surgery, dental procedure, or have had a recent surgery. You should stop taking CABOMETRYX at least 3 weeks before planned surgery. See **“What are the possible side effects of CABOMETRYX?”**
- are pregnant, or plan to become pregnant. CABOMETRYX can harm your unborn baby.
 - If you are able to become pregnant, your healthcare provider will check your pregnancy status before you start treatment with CABOMETRYX.
 - Females who are able to become pregnant should use effective birth control (contraception) during treatment and for 4 months after your final dose of CABOMETRYX.
 - Talk to your healthcare provider about birth control methods that may be right for you.
 - If you become pregnant or think you are pregnant, tell your healthcare provider right away.
- are breastfeeding or plan to breastfeed. It is not known if CABOMETRYX passes into your breast milk. Do not breastfeed during treatment and for 4 months after your final dose of CABOMETRYX.

Tell your healthcare provider about all the medicines you take, including prescription or over-the-counter medicines, vitamins, and herbal supplements. CABOMETRYX and certain other medicines may affect each other causing side effects.

How should I take CABOMETRYX?

- Take CABOMETRYX exactly as your healthcare provider tells you to take it.
- **Do not** take CABOMETRYX with food. Take CABOMETRYX at least 1 hour before or at least 2 hours after eating.
- Swallow CABOMETRYX tablets whole with a full glass (at least 8 ounces) of water.
- **Do not** crush CABOMETRYX tablets.
- If you miss a dose and your next dose is in:
 - less than 12 hours, take your next dose at the normal time. Do not make up the missed dose.
 - 12 hours or more, take the missed dose as soon as you remember. Take your next dose at the normal time.

What should I avoid while taking CABOMETRYX?

Do not drink grapefruit juice, eat grapefruit or take supplements that contain grapefruit or St. John’s wort during treatment with CABOMETRYX.

What are the possible side effects of CABOMETRYX?

CABOMETRYX may cause serious side effects, including:

- **bleeding (hemorrhage).** CABOMETRYX can cause severe bleeding that may lead to death. Tell your healthcare provider right away if you get any signs of bleeding during treatment with CABOMETRYX, including:
 - coughing up blood or blood clots
 - red or black (looks like tar) stools

- vomiting blood or if your vomit looks like coffee-grounds
 - menstrual bleeding that is heavier than normal
 - any unusual or heavy bleeding
 - **a tear in your stomach or intestinal wall (perforation) or an abnormal connection between 2 parts of your body (fistula).** Tell your healthcare provider right away if you get tenderness or pain in your stomach-area (abdomen).
 - **blood clots, stroke, heart attack, and chest pain.** Get emergency help right away if you get:
 - swelling or pain in your arms or legs
 - sudden confusion, trouble speaking or understanding
 - shortness of breath
 - sudden trouble seeing in one or both eyes
 - feel lightheaded or faint
 - sudden trouble walking
 - sweating more than usual
 - dizziness, loss of balance or coordination
 - numbness or weakness of your face, arm or leg, especially on one side of your body
 - a sudden severe headache
 - **high blood pressure (hypertension).** Hypertension is common with CABOMETYX and sometimes can be severe. Your healthcare provider will check your blood pressure before starting CABOMETYX and during treatment with CABOMETYX. If needed, your healthcare provider may prescribe medicine to treat your high blood pressure.
 - **diarrhea.** Diarrhea is common with CABOMETYX and can be severe. If needed, your healthcare provider may prescribe medicine to treat your diarrhea. Tell your healthcare provider right away, if you have frequent loose, watery bowel movements.
 - **a skin problem called hand-foot skin reaction.** Hand-foot skin reactions are common and can be severe. Tell your healthcare provider right away if you have rashes, redness, pain, swelling, or blisters on the palms of your hands or soles of your feet.
 - **protein in your urine and possible kidney problems.** Symptoms may include swelling in your hands, arms, legs, or feet.
 - **severe jaw bone problems (osteonecrosis).** Symptoms may include jaw pain, toothache, or sores on your gums. Your healthcare provider should examine your mouth before you start and during treatment with CABOMETYX. Tell your dentist that you are taking CABOMETYX. It is important for you to practice good mouth care during treatment with CABOMETYX.
 - **wound healing problems.** Wound healing problems have happened in some people who take CABOMETYX. Tell your healthcare provider if you plan to have any surgery before or during treatment with CABOMETYX.
 - You should stop taking CABOMETYX at least 3 weeks before planned surgery.
 - Your healthcare provider should tell you when you may start taking CABOMETYX again after surgery.
 - **Reversible Posterior Leukoencephalopathy Syndrome (RPLS).** A condition called reversible posterior leukoencephalopathy syndrome can happen during treatment with CABOMETYX. Tell your healthcare provider right away if you have headaches, seizures, confusion, changes in vision, or problems thinking.
 - CABOMETYX may cause fertility problems in females and males, which may affect your ability to have children. Talk to your healthcare provider if you have concerns about fertility.
- Your healthcare provider may change your dose, temporarily stop, or permanently stop treatment with CABOMETYX if you have certain side effects.
- The most common side effects of CABOMETYX include:
- tiredness
 - decreased appetite
 - weight loss
 - nausea
 - vomiting
 - changes in certain blood tests
- Tell your healthcare provider if you have any side effect that bothers you or that does not go away. These are not all of the possible side effects of CABOMETYX. Call your doctor for medical advice about side effects. You may report side effects to FDA at 1-800-FDA-1088.

How should I store CABOMETYX?

- Store CABOMETYX at room temperature 68°F to 77°F (20°C to 25°C).

Keep CABOMETYX and all medicines out of the reach of children.

General information about the safe and effective use of CABOMETYX.

Medicines are sometimes prescribed for purposes other than those listed in a Patient Information leaflet. Do not use CABOMETYX for a condition for which it was not prescribed. Do not give CABOMETYX to other people, even if they have the same symptoms you have. It may harm them.

You can ask your healthcare provider or pharmacist for information about CABOMETYX that is written for health professionals.

What are the ingredients in CABOMETYX?

Active ingredient: cabozantinib

Inactive ingredients: microcrystalline cellulose, lactose anhydrous, hydroxypropyl cellulose, croscarmellose sodium, colloidal silicon dioxide, and magnesium stearate. The film coating contains hypromellose, titanium dioxide, triacetin, and iron oxide yellow.

Manufactured for Exelixis, Inc. Alameda, CA 94502

For more information, go to www.cabometryx.com or call 1-855-292-3935.

This Patient Information has been approved by the U.S. Food and Drug Administration. Issued: 01/2020

HIGHLIGHTS OF PRESCRIBING INFORMATION

These highlights do not include all the information needed to use CABOMETYX safely and effectively. See full prescribing information for CABOMETYX.

CABOMETYX® (cabozantinib) tablets, for oral use

Initial U.S. Approval: 2012

RECENT MAJOR CHANGES

Warnings and Precautions, Impaired Wound Healing (5.9) 1/2020

INDICATIONS AND USAGE

CABOMETYX is a kinase inhibitor indicated for the treatment of

- patients with advanced renal cell carcinoma (RCC) (1.1)
- patients with hepatocellular carcinoma (HCC) who have been previously treated with sorafenib (1.2)

DOSAGE AND ADMINISTRATION

- Recommended Dose: 60 mg orally, once daily. (2.2, 2.3)
- Administer at least 1 hour before or at least 2 hours after eating. (2.1)
- Do NOT substitute CABOMETYX tablets with cabozantinib capsules. (2.1)

DOSAGE FORMS AND STRENGTHS

Tablets: 20 mg, 40 mg, and 60 mg. (3)

CONTRAINDICATIONS

None. (4)

WARNINGS AND PRECAUTIONS

- Hemorrhage: Do not administer CABOMETYX if recent history of hemorrhage. (5.1)
- Perforations and Fistulas: Monitor for symptoms. Discontinue CABOMETYX for Grade 4 fistula or perforation. (5.2)
- Thrombotic Events: Discontinue CABOMETYX for myocardial infarction or serious venous or arterial thromboembolic events. (5.3)
- Hypertension and Hypertensive Crisis: Monitor blood pressure regularly. Interrupt for hypertension that is not adequately controlled with anti-hypertensive therapy. Discontinue CABOMETYX for hypertensive crisis or severe hypertension that cannot be controlled with anti-hypertensive therapy. (5.4)
- Diarrhea: May be severe. Interrupt CABOMETYX immediately until diarrhea resolves or decreases to Grade 1. Recommend standard antidiarrheal treatments. (5.5)

- Palmar-Plantar Erythrodysesthesia (PPE): Interrupt CABOMETYX treatment until PPE resolves or decreases to Grade 1. (5.6)
- Proteinuria: Monitor urine protein. Discontinue for nephrotic syndrome. (5.7)
- Osteonecrosis of the jaw (ONJ): Withhold CABOMETYX for at least 3 weeks prior to invasive dental procedures and for development of ONJ. (5.8)
- Impaired Wound Healing: Withhold CABOMETYX for at least 3 weeks before elective surgery. Do not administer for at least 2 weeks following major surgery and adequate wound healing. The safety of resumption of CABOMETYX after resolution of wound healing complications has not been established. (5.9)
- Reversible Posterior Leukoencephalopathy Syndrome (RPLS): Discontinue CABOMETYX. (5.10)
- Embryo-Fetal Toxicity: Can cause fetal harm. Advise females of reproductive potential of the potential risk to a fetus and to use effective contraception. (5.11, 8.1, 8.3)

ADVERSE REACTIONS

The most common ($\geq 25\%$) adverse reactions are: diarrhea, fatigue, decreased appetite, palmar-plantar erythrodysesthesia (PPE), nausea, hypertension, and vomiting. (6.1)

To report SUSPECTED ADVERSE REACTIONS, contact Exelixis, Inc. at 1-855-500-3935 or FDA at 1-800-FDA-1088 or www.fda.gov/medwatch.

DRUG INTERACTIONS

- Strong CYP3A4 inhibitors: Reduce the CABOMETYX dosage if coadministration cannot be avoided. (2.5, 7.1)
- Strong CYP3A4 inducers: Increase the CABOMETYX dosage if coadministration cannot be avoided. (2.6, 7.1)

USE IN SPECIFIC POPULATIONS

- Hepatic Impairment: Reduce the CABOMETYX dosage for patients with moderate hepatic impairment. Avoid in patients with severe hepatic impairment. (2.7, 8.6)
- Lactation: Advise not to breastfeed. (8.2)

See 17 for PATIENT COUNSELING INFORMATION and FDA-approved patient labeling.

Revised: 1/2020

FULL PRESCRIBING INFORMATION: CONTENTS*

1	INDICATIONS AND USAGE	5.10 Reversible Posterior Leukoencephalopathy Syndrome
	1.1 Renal Cell Carcinoma	5.11 Embryo-Fetal Toxicity
	1.2 Hepatocellular Carcinoma	6 ADVERSE REACTIONS
2	DOSAGE AND ADMINISTRATION	6.1 Clinical Trial Experience
	2.1 Important Dosage Information	7 DRUG INTERACTIONS
	2.2 Recommended Dosage for Renal Cell Carcinoma	7.1 Effects of Other Drugs on CABOMETYX
	2.3 Recommended Dosage for Hepatocellular Carcinoma	8 USE IN SPECIFIC POPULATIONS
	2.4 Dosage Modifications for Adverse Reactions	8.1 Pregnancy
	2.5 Dosage Modifications for Coadministration with Strong CYP3A4 Inhibitors	8.2 Lactation
	2.6 Dosage Modifications for Coadministration with Strong CYP3A4 Inducers	8.3 Females and Males of Reproductive Potential
	2.7 Dosage Modifications for Patients with Moderate and Severe Hepatic Impairment	8.4 Pediatric Use
3	DOSAGE FORMS AND STRENGTHS	8.5 Geriatric Use
4	CONTRAINDICATIONS	8.6 Hepatic Impairment
5	WARNINGS AND PRECAUTIONS	8.7 Renal Impairment
	5.1 Hemorrhage	10 OVERDOSAGE
	5.2 Perforations and Fistulas	11 DESCRIPTION
	5.3 Thrombotic Events	12 CLINICAL PHARMACOLOGY
	5.4 Hypertension and Hypertensive Crisis	12.1 Mechanism of Action
	5.5 Diarrhea	12.2 Pharmacodynamics
	5.6 Palmar-Plantar Erythrodysesthesia	12.3 Pharmacokinetics
	5.7 Proteinuria	13 NONCLINICAL TOXICOLOGY
	5.8 Osteonecrosis of the Jaw	13.1 Carcinogenesis, Mutagenesis, Impairment of Fertility
	5.9 Wound Complications	14 CLINICAL STUDIES
		14.1 Renal Cell Carcinoma
		14.2 Hepatocellular Carcinoma
		16 HOW SUPPLIED/STORAGE AND HANDLING
		17 PATIENT COUNSELING INFORMATION

*Sections or subsections omitted from the full prescribing information are not listed.

FULL PRESCRIBING INFORMATION

1 INDICATIONS AND USAGE

1.1 Renal Cell Carcinoma

CABOMETYX is indicated for the treatment of patients with advanced renal cell carcinoma (RCC).

1.2 Hepatocellular Carcinoma

CABOMETYX is indicated for the treatment of patients with hepatocellular carcinoma (HCC) who have been previously treated with sorafenib.

2 DOSAGE AND ADMINISTRATION

2.1 Important Dosage Information

- Stop treatment with CABOMETYX at least 3 weeks prior to scheduled surgery, including dental surgery [see *Warnings and Precautions (5.1, 5.8, 5.9)*].
- Do not substitute CABOMETYX tablets with cabozantinib capsules.
- Do not administer CABOMETYX with food. Administer at least 1 hour before or at least 2 hours after eating [see *Clinical Pharmacology (12.3)*].
- Swallow CABOMETYX tablets whole. Do not crush CABOMETYX tablets.
- Do not take a missed dose within 12 hours of the next dose.
- Modify the dose for certain patients with hepatic impairment and for patients taking drugs known to strongly induce or inhibit CYP450 [see *Dosage and Administration (2.5, 2.6, 2.7)*].

2.2 Recommended Dosage for Renal Cell Carcinoma

The recommended dosage of CABOMETYX is 60 mg once daily without food until the patient no longer experiences clinical benefit or experiences unacceptable toxicity.

2.3 Recommended Dosage for Hepatocellular Carcinoma

The recommended dosage of CABOMETYX is 60 mg once daily without food until disease progression or unacceptable toxicity.

2.4 Dosage Modifications for Adverse Reactions

Withhold CABOMETYX for:

- Intolerable Grade 2 adverse reactions
- Grade 3 or 4 adverse reactions
- Osteonecrosis of the jaw

Upon resolution/improvement (i.e., return to baseline or resolution to Grade 1) of an adverse reaction, reduce the dose as follows:

- If previously receiving 60 mg daily dose, resume treatment at 40 mg daily.
- If previously receiving 40 mg daily dose, resume treatment at 20 mg daily.
- If previously receiving 20 mg daily dose, resume at 20 mg if tolerated, otherwise, discontinue CABOMETYX.

Permanently discontinue CABOMETYX for any of the following:

- Severe hemorrhage
- Development of gastrointestinal (GI) perforation or Grade 4 fistula
- Acute myocardial infarction or arterial or venous thromboembolic events that require medical intervention
- Severe hypertension that cannot be controlled with anti-hypertensive therapy or hypertensive crisis
- Nephrotic syndrome
- Reversible posterior leukoencephalopathy syndrome

2.5 Dosage Modifications for Coadministration with Strong CYP3A4 Inhibitors

Reduce the daily CABOMETYX dose by 20 mg (for example, from 60 mg to 40 mg daily or from 40 mg to 20 mg daily). Resume the dose that was used prior to initiating the strong CYP3A4 inhibitor 2 to 3 days after discontinuation of the strong inhibitor [see *Drug Interactions (7.1)*, *Clinical Pharmacology (12.3)*].

2.6 Dosage Modifications for Coadministration with Strong CYP3A4 Inducers

Increase the daily CABOMETYX dose by 20 mg (for example, from 60 mg to 80 mg daily or from 40 mg to 60 mg daily) as tolerated. Resume the dose that was used prior to initiating the strong CYP3A4 inducer 2 to 3 days after discontinuation of the strong inducer. Do not exceed a daily dose of 80 mg [see *Drug Interactions (7.1)*, *Clinical Pharmacology (12.3)*].

2.7 Dosage Modifications for Patients with Moderate and Severe Hepatic Impairment

Reduce the starting dose of CABOMETYX to 40 mg once daily in patients with moderate hepatic impairment (Child-Pugh B). Avoid CABOMETYX in patients with severe hepatic impairment (Child-Pugh C) [see *Use in Specific Populations (8.6)*, *Clinical Pharmacology (12.3)*].

3 DOSAGE FORMS AND STRENGTHS

Tablets:

- 60 mg: yellow film-coated, oval shaped with no score, and debossed with “XL” on one side and “60” on the other side.
- 40 mg: yellow film-coated, triangle shaped with no score, and debossed with “XL” on one side and “40” on the other side.
- 20 mg: yellow film-coated, round with no score, and debossed with “XL” on one side and “20” on the other side.

4 CONTRAINDICATIONS

None.

5 WARNINGS AND PRECAUTIONS

5.1 Hemorrhage

Severe and fatal hemorrhages occurred with CABOMETYX [see *Adverse Reactions (6.1)*]. The incidence of Grade 3 to 5 hemorrhagic events was 5% in CABOMETYX-treated patients in RCC and HCC studies.

Discontinue CABOMETYX for Grade 3 or 4 hemorrhage [see *Dosage and Administration (2.4)*]. Do not administer CABOMETYX to patients who have a recent history of hemorrhage, including hemoptysis, hematemesis, or melena.

5.2 Perforations and Fistulas

Fistulas, including fatal cases, occurred in 1% of CABOMETYX-treated patients [see *Adverse Reactions (6.1)*]. Gastrointestinal (GI) perforations, including fatal cases, occurred in 1% of CABOMETYX-treated patients.

Monitor patients for signs and symptoms of fistulas and perforations, including abscess and sepsis. Discontinue CABOMETYX in patients who experience a Grade 4 fistula or a GI perforation [see *Dosage and Administration (2.4)*].

5.3 Thrombotic Events

CABOMETYX increased the risk of thrombotic events [see *Adverse Reactions (6.1)*]. Venous thromboembolism occurred in 7% (including 4% pulmonary embolism) and arterial thromboembolism occurred in 2% of CABOMETYX-treated patients. Fatal thrombotic events occurred in CABOMETYX-treated patients.

Discontinue CABOMETYX in patients who develop an acute myocardial infarction or serious arterial or venous thromboembolic events that require medical intervention [see *Dosage and Administration (2.4)*].

5.4 Hypertension and Hypertensive Crisis

CABOMETYX can cause hypertension, including hypertensive crisis [see *Adverse Reactions (6.1)*]. Hypertension was reported in 36% (17% Grade 3 and <1% Grade 4) of CABOMETYX-treated patients.

Do not initiate CABOMETYX in patients with uncontrolled hypertension. Monitor blood pressure regularly during CABOMETYX treatment. Withhold CABOMETYX for hypertension that is not adequately controlled with medical management; when controlled, resume CABOMETYX at a reduced dose [see *Dosage and Administration (2.4)*]. Discontinue CABOMETYX for severe hypertension that cannot be controlled with anti-hypertensive therapy or for hypertensive crisis.

5.5 Diarrhea

Diarrhea occurred in 63% of patients treated with CABOMETYX. Grade 3 diarrhea occurred in 11% of patients treated with CABOMETYX [see *Adverse Reactions (6.1)*].

Withhold CABOMETYX until improvement to Grade 1 and resume CABOMETYX at a reduced dose for intolerable Grade 2 diarrhea, Grade 3 diarrhea that cannot be managed with standard antidiarrheal treatments, or Grade 4 diarrhea [see *Dosage and Administration (2.4)*].

5.6 Palmar-Plantar Erythrodysesthesia

Palmar-plantar erythrodysesthesia (PPE) occurred in 44% of patients treated with CABOMETYX [see *Adverse Reactions (6.1)*]. Grade 3 PPE occurred in 13% of patients treated with CABOMETYX.

Withhold CABOMETYX until improvement to Grade 1 and resume CABOMETYX at a reduced dose for intolerable Grade 2 PPE or Grade 3 PPE [see *Dosage and Administration (2.4)*].

5.7 Proteinuria

Proteinuria was observed in 7% of patients receiving CABOMETYX [see *Adverse Reactions (6.1)*]. Monitor urine protein regularly during CABOMETYX treatment. Discontinue CABOMETYX in patients who develop nephrotic syndrome [see *Dosage and Administration (2.4)*].

5.8 Osteonecrosis of the Jaw

Osteonecrosis of the jaw (ONJ) occurred in <1% of patients treated with CABOMETYX [see *Adverse Reactions (6.1)*]. ONJ can manifest as jaw pain, osteomyelitis, osteitis, bone erosion, tooth or periodontal infection, toothache, gingival ulceration or erosion, persistent jaw pain or slow healing of the mouth or jaw after dental surgery. Perform an oral examination prior to initiation of CABOMETYX and periodically during CABOMETYX. Advise patients regarding good oral hygiene practices. Withhold CABOMETYX for at least 3 weeks prior to scheduled dental surgery or invasive dental procedures, if possible. Withhold CABOMETYX for development of ONJ until complete resolution [see *Dosage and Administration (2.1)*].

5.9 Impaired Wound Healing

Wound complications occurred with CABOMETYX [see *Adverse Reactions (6.1)*]. Withhold CABOMETYX for at least 3 weeks prior to elective surgery [see *Dosage and Administration (2.1)*]. Do not administer CABOMETYX for at least 2 weeks after major surgery and until adequate wound healing. The safety of resumption of CABOMETYX after resolution of wound healing complications has not been established.

5.10 Reversible Posterior Leukoencephalopathy Syndrome

Reversible Posterior Leukoencephalopathy Syndrome (RPLS), a syndrome of subcortical vasogenic edema diagnosed by characteristic finding on MRI, can occur with CABOMETYX. Perform an evaluation for RPLS in any patient presenting with seizures, headache, visual disturbances, confusion or altered mental function. Discontinue CABOMETYX in patients who develop RPLS [see *Dosage and Administration (2.4)*].

5.11 Embryo-Fetal Toxicity

Based on data from animal studies and its mechanism of action, CABOMETYX can cause fetal harm when administered to a pregnant woman. Cabozantinib administration to pregnant animals during organogenesis resulted in embryoletality at exposures below those occurring clinically at the recommended dose, and in increased incidences of skeletal variations in rats and visceral variations and malformations in rabbits.

Advise pregnant women of the potential risk to a fetus. Advise females of reproductive potential to use effective contraception during treatment with CABOMETYX and for 4 months after the last dose [see *Use in Specific Populations (8.1, 8.3)*, *Clinical Pharmacology (12.1)*].

6 ADVERSE REACTIONS

The following clinically significant adverse reactions are discussed elsewhere in the labeling:

- Hemorrhage [see *Warnings and Precautions (5.1)*]
- Perforations and Fistulas [see *Warnings and Precautions (5.2)*]
- Thrombotic Events [see *Warnings and Precautions (5.3)*]
- Hypertension and Hypertensive Crisis [see *Warnings and Precautions (5.4)*]
- Diarrhea [see *Warnings and Precautions (5.5)*]
- Palmar-plantar Erythrodysesthesia [see *Warnings and Precautions (5.6)*]
- Proteinuria [see *Warnings and Precautions (5.7)*]
- Osteonecrosis of the Jaw [see *Warnings and Precautions (5.8)*]
- Impaired Wound Healing [see *Warnings and Precautions (5.9)*]
- Reversible Posterior Leukoencephalopathy Syndrome [see *Warnings and Precautions (5.10)*]

6.1 Clinical Trial Experience

The data described in the WARNINGS AND PRECAUTIONS section and below reflect exposure to CABOMETYX as a single agent in 409 patients with RCC enrolled in randomized,

active-controlled trials (CABOSUN, METEOR) and 467 patients with HCC enrolled in a randomized, placebo-controlled trial (CELESTIAL).

Because clinical trials are conducted under widely varying conditions, adverse reaction rates observed in the clinical trials of a drug cannot be directly compared to rates in the clinical trials of another drug and may not reflect the rates observed in practice.

Renal Cell Carcinoma

METEOR

The safety of CABOMETYX was evaluated in METEOR, a randomized, open-label trial in which 331 patients with advanced renal cell carcinoma received CABOMETYX 60 mg once daily and 322 patients received everolimus 10 mg once daily until disease progression or unacceptable toxicity. Patients on both arms who had disease progression could continue treatment at the discretion of the investigator [see *Clinical Studies (14.1)*]. The median duration of treatment was 7.6 months (range 0.3 – 20.5) for patients receiving CABOMETYX and 4.4 months (range 0.21 – 18.9) for patients receiving everolimus.

Adverse reactions which occurred in $\geq 25\%$ of CABOMETYX-treated patients, in order of decreasing frequency, were: diarrhea, fatigue, nausea, decreased appetite, palmar-plantar erythrodysesthesia (PPE), hypertension, vomiting, weight decreased, and constipation. Grade 3-4 adverse reactions and laboratory abnormalities which occurred in $\geq 5\%$ of patients were hypertension, diarrhea, fatigue, PPE, hyponatremia, hypophosphatemia, hypomagnesemia, lymphopenia, anemia, hypokalemia, and increased GGT.

The dose was reduced in 60% of patients receiving CABOMETYX and in 24% of patients receiving everolimus. Twenty percent (20%) of patients received CABOMETYX 20 mg once daily as their lowest dose. The most frequent adverse reactions leading to dose reduction in patients treated with CABOMETYX were: diarrhea, PPE, fatigue, and hypertension. Adverse reactions leading to dose interruption occurred in 70% patients receiving CABOMETYX and in 59% patients receiving everolimus. Adverse reactions led to study treatment discontinuation in 10% of patients receiving CABOMETYX and in 10% of patients receiving everolimus. The most frequent adverse reactions leading to permanent discontinuation in patients treated with CABOMETYX were decreased appetite (2%) and fatigue (1%).

Table 1. Adverse Reactions Occurring in $\geq 10\%$ Patients Who Received CABOMETYX in METEOR

Adverse Reaction	CABOMETYX (n=331) ¹		Everolimus (n=322)	
	All Grades ²	Grade 3-4	All Grades ²	Grade 3-4
	Percentage (%) of Patients			
Gastrointestinal				
Diarrhea	74	11	28	2
Nausea	50	4	28	<1
Vomiting	32	2	14	<1
Stomatitis	22	2	24	2
Constipation	25	<1	19	<1
Abdominal pain ³	23	4	13	2
Dyspepsia	12	<1	5	0

Adverse Reaction	CABOMETYX (n=331) ¹		Everolimus (n=322)	
	All Grades ²	Grade 3-4	All Grades ²	Grade 3-4
	Percentage (%) of Patients			
General				
Fatigue	56	9	47	7
Mucosal inflammation	19	<1	23	3
Asthenia	19	4	16	2
Metabolism and Nutrition				
Decreased appetite	46	3	34	<1
Skin and Subcutaneous Tissue				
Palmar-plantar erythrodysesthesia	42	8	6	<1
Rash ⁴	23	<1	43	<1
Dry skin	11	0	10	0
Vascular				
Hypertension ⁵	39	16	8	3
Investigations				
Weight decreased	31	2	12	0
Nervous System				
Dysgeusia	24	0	9	0
Headache	11	<1	12	<1
Dizziness	11	0	7	0
Endocrine				
Hypothyroidism	21	0	<1	<1
Respiratory, Thoracic, and Mediastinal				
Dysphonia	20	<1	4	0
Dyspnea	19	3	29	4
Cough	18	<1	33	<1
Blood and Lymphatic				
Anemia	17	5	38	16
Musculoskeletal and Connective Tissue				
Pain in extremity	14	1	8	<1
Muscle spasms	13	0	5	0
Arthralgia	11	<1	14	1
Renal and Urinary				
Proteinuria	12	2	9	<1

¹ One subject randomized to everolimus received cabozantinib.

² National Cancer Institute (NCI) Common Terminology Criteria for Adverse Events (CTCAE) Version 4.0

³ Includes the following terms: abdominal pain, abdominal pain upper, and abdominal pain lower

⁴ Includes the following terms: rash, rash erythematous, rash follicular, rash macular, rash papular, rash pustular, rash vesicular, genital rash, intermittent leg rash, rash on scrotum and penis, rash maculo-papular, rash pruritic, contact dermatitis, dermatitis acneiform

⁵ Includes the following terms: hypertension, blood pressure increased, hypertensive crisis, blood pressure fluctuation

Other clinically important adverse reactions (all grades) that were reported in <10% of patients treated with CABOMETYX included: wound complications (2%), convulsion (<1%), pancreatitis (<1%), osteonecrosis of the jaw (<1%), and hepatitis cholestatic (<1%).

Table 2. Laboratory Abnormalities Occurring in ≥ 25% Patients Who Received CABOMETYX in METEOR

Laboratory Abnormality	CABOMETYX (n=331)		Everolimus (n=322)	
	All Grades	Grade 3-4	All Grades	Grade 3-4
	Percentage (%) of Patients			
Chemistry				
Increased AST	74	3	40	<1
Increased ALT	68	3	32	<1
Increased creatinine	58	<1	71	0
Increased triglycerides	53	4	73	13
Hypophosphatemia	48	8	36	5
Hyperglycemia	37	2	59	8
Hypoalbuminemia	36	2	28	<1
Increased ALP	35	2	29	1
Hypomagnesemia	31	7	4	<1
Hyponatremia	30	8	26	6
Increased GGT	27	5	43	9
Hematology				
Leukopenia	35	<1	31	<1
Neutropenia	31	2	17	<1
Anemia ¹	31	4	71	17
Lymphopenia	25	7	39	12
Thrombocytopenia	25	<1	27	<1
ALP, alkaline phosphatase; ALT, alanine aminotransferase; AST, aspartate aminotransferase; GGT, gamma glutamyl transferase. NCI CTCAE, Version 4.0 ¹ Based on laboratory abnormalities				

CABOSUN

The safety of CABOMETYX was evaluated in CABOSUN, a randomized, open-label trial in patients with advanced renal cell carcinoma, in which 78 patients received CABOMETYX 60 mg once daily and 72 patients received sunitinib 50 mg once daily (4 weeks on treatment followed by 2 weeks off), until disease progression or unacceptable toxicity [see *Clinical Studies (14.1)*]. The median duration of treatment was 6.5 months (range 0.2 – 28.7) for patients receiving CABOMETYX and 3.1 months (range 0.2 – 25.5) for patients receiving sunitinib.

Within 30 days of treatment, there were 4 deaths in patients treated with CABOMETYX and 6 deaths in patients treated with sunitinib. Of the 4 patients treated with CABOMETYX, 2 patients died due to gastrointestinal perforation, 1 patient had acute renal failure, and 1 patient died due to clinical deterioration. All Grade 3-4 adverse reactions were collected in the entire safety population. The most frequent Grade 3-4 adverse reactions (≥5%) in patients treated with

CABOMETYX were hypertension, diarrhea, hyponatremia, hypophosphatemia, PPE, fatigue, increased ALT, decreased appetite, stomatitis, pain, hypotension, and syncope.

The median average daily dose was 50.3 mg for CABOMETYX and 44.7 mg for sunitinib (excluding scheduled sunitinib non-dosing days). The dose was reduced in 46% of patients receiving CABOMETYX and in 35% of patients receiving sunitinib. The dose was held in 73% of patients receiving CABOMETYX and in 71% of patients receiving sunitinib. Based on patient disposition, 21% of patients receiving CABOMETYX and 22% of patients receiving sunitinib discontinued due to an adverse reaction.

Table 3. Grade 3-4 Adverse Reactions Occurring in \geq 1% Patients Who Received CABOMETYX in CABOSUN

Adverse Reaction	CABOMETYX (n = 78)	Sunitinib (n = 72)
	Grade 3-4 ¹	Grade 3-4 ¹
	Percentage (%) of Patients	
Patients with any Grade 3-4 Adverse Reaction	68	65
Gastrointestinal		
Diarrhea	10	11
Stomatitis	5	6
Nausea	3	4
Vomiting	1	3
Constipation	1	0
General		
Fatigue	6	17
Pain	5	0
Metabolism and Nutrition		
Hyponatremia ²	9	8
Hypophosphatemia ²	9	7
Decreased appetite	5	1
Dehydration	4	1
Hypocalcemia ²	3	0
Hypomagnesemia ²	3	0
Hyperkalemia ²	1	3
Skin and Subcutaneous Tissue		
Palmar-plantar erythrodysesthesia	8	4
Skin ulcer	3	0
Vascular		
Hypertension ³	28	21
Hypotension	5	1
Angiopathy	1	1
Investigations		
Increased ALT ²	5	0
Weight decreased	4	0
Increased AST ²	3	3
Increased blood creatinine ²	3	3
Lymphopenia ²	1	6

Adverse Reaction	CABOMETYX (n = 78)	Sunitinib (n = 72)
	Grade 3-4 ¹	Grade 3-4 ¹
	Percentage (%) of Patients	
Thrombocytopenia ²	1	11
Nervous System		
Syncope	5	0
Respiratory, Thoracic, and Mediastinal		
Dyspnea	1	6
Dysphonia	1	0
Blood and Lymphatic		
Anemia	1	3
Psychiatric		
Depression	4	0
Confusional state	1	1
Infections		
Lung infection	4	0
Musculoskeletal and Connective Tissue		
Back pain	4	0
Bone pain	3	1
Pain in extremity	3	0
Arthralgia	1	0
Renal and Urinary		
Renal failure acute	4	1
Proteinuria	3	1

ALT, alanine aminotransferase; AST, aspartate aminotransferase
¹ NCI CTCAE Version 4.0
² Laboratory abnormalities are reported as adverse reactions and not based on shifts in laboratory values
³ Includes the following term: hypertension

Hepatocellular Carcinoma

The safety of CABOMETYX was evaluated in CELESTIAL, a randomized, double-blind, placebo-controlled trial in which 704 patients with advanced hepatocellular carcinoma were randomized to receive CABOMETYX 60 mg orally once daily (n=467) or placebo (n=237) until disease progression or unacceptable toxicity [see *Clinical Studies (14.2)*]. The median duration of treatment was 3.8 months (range 0.1 – 37.3) for patients receiving CABOMETYX and 2.0 months (range 0.0 – 27.2) for patients receiving placebo. The population exposed to CABOMETYX was 81% male, 56% White, and had a median age of 64 years.

Adverse reactions occurring in $\geq 25\%$ of CABOMETYX-treated patients, in order of decreasing frequency were: diarrhea, decreased appetite, PPE, fatigue, nausea, hypertension, and vomiting. Grade 3-4 adverse reactions which occurred in $\geq 5\%$ of patients were PPE, hypertension, fatigue, diarrhea, asthenia, and decreased appetite. There were 6 adverse reactions leading to death in patients receiving CABOMETYX (hepatic failure, hepatorenal syndrome, esophagobronchial fistula, portal vein thrombosis, pulmonary embolism, upper gastrointestinal hemorrhage).

The median average daily dose was 35.8 mg for CABOMETYX. The dose was reduced in 62% of patients receiving CABOMETYX; 33% of patients required a reduction to 20 mg daily. The most frequent adverse reactions or laboratory abnormalities leading to dose reduction of CABOMETYX were: PPE, diarrhea, fatigue, hypertension, and increased AST. Adverse reactions leading to dose interruption occurred in 84% patients receiving CABOMETYX. Adverse reactions leading to permanent discontinuation of CABOMETYX occurred in 16% of patients. The most frequent adverse reactions leading to permanent discontinuation of CABOMETYX were PPE (2%), fatigue (2%), decreased appetite (1%), diarrhea (1%), and nausea (1%).

Table 4. Adverse Reactions Occurring in \geq 5% of CABOMETYX-Treated Patients in CELESTIAL¹

Adverse Reaction	CABOMETYX (n = 467)		Placebo (n = 237)	
	All Grades ²	Grade 3-4	All Grades ²	Grade 3-4
	Percentage (%) of Patients			
Gastrointestinal				
Diarrhea	54	10	19	2
Nausea	31	2	18	2
Vomiting	26	<1	12	3
Stomatitis	13	2	2	0
Dyspepsia	10	0	3	0
General				
Fatigue	45	10	30	4
Asthenia	22	7	8	2
Mucosal inflammation	14	2	2	<1
Metabolism and Nutrition				
Decreased appetite	48	6	18	<1
Skin and Subcutaneous Tissue				
Palmar-plantar erythrodysesthesia	46	17	5	0
Rash ³	21	2	9	<1
Vascular				
Hypertension ⁴	30	16	6	2
Investigations				
Weight decreased	17	1	6	0
Nervous System				
Dysgeusia	12	0	2	0
Endocrine				
Hypothyroidism	8	<1	<1	0
Respiratory, Thoracic, and Mediastinal				
Dysphonia	19	1	2	0
Dyspnea	12	3	10	<1
Musculoskeletal and Connective Tissue				
Pain in extremity	9	<1	4	1
Muscle spasms	8	<1	2	0

Adverse Reaction	CABOMETYX (n = 467)		Placebo (n = 237)	
	All Grades ²	Grade 3-4	All Grades ²	Grade 3-4
¹ Includes terms with a between-arm difference of $\geq 5\%$ (all grades) or $\geq 2\%$ (Grade 3-4)				
² NCI CTCAE Version 4.0				
³ Includes the following terms: rash, rash erythematous, rash generalized, rash macular, rash maculopapular, rash papular, rash pruritic, rash pustular, rash vesicular, dermatitis, dermatitis acneiform, dermatitis contact, dermatitis diaper, dermatitis exfoliative, dermatitis infected				
⁴ Includes the following terms: hypertension, blood pressure diastolic increased, blood pressure increased				

Table 5. Laboratory Abnormalities Occurring in $\geq 5\%$ of CABOMETYX-Treated Patients in CELESTIAL¹

Laboratory Abnormality	CABOMETYX N=467		Placebo N=237	
	All Grades	Grade 3-4	All Grades	Grade 3-4
Percentage of Patients				
Chemistry				
Increased LDH	84	9	29	2
Increased ALT	73	12	37	6
Increased AST	73	24	46	19
Hypoalbuminemia	51	1	32	1
Increased ALP	43	8	38	6
Hypophosphatemia	25	9	8	4
Hypokalemia	23	6	6	1
Hypomagnesemia	22	3	3	0
Increased amylase	16	2	9	2
Hypocalcemia	8	2	0	0
Hematology				
Decreased platelets	54	10	16	1
Neutropenia	43	7	8	1
Increased hemoglobin	8	0	1	0
¹ Includes laboratory abnormalities with a between-arm difference of $\geq 5\%$ (all grades) or $\geq 2\%$ (Grade 3-4) ALP, alkaline phosphatase; ALT, alanine aminotransferase; AST, aspartate aminotransferase; LDH, blood lactate dehydrogenase				

7 DRUG INTERACTIONS

7.1 Effects of Other Drugs on CABOMETYX

Strong CYP3A4 Inhibitors

Coadministration of a cabozantinib capsule formulation with a strong CYP3A4 inhibitor increased the exposure of cabozantinib, which may increase the risk of exposure-related adverse reactions [see *Clinical Pharmacology (12.3)*]. Avoid coadministration of CABOMETYX with strong CYP3A4 inhibitors. Reduce the dosage of CABOMETYX if coadministration with strong

CYP3A4 inhibitors cannot be avoided [see *Dosage and Administration (2.5)*]. Avoid grapefruit or grapefruit juice which may also increase exposure of cabozantinib.

Strong CYP3A Inducers

Coadministration of a cabozantinib capsule formulation with a strong CYP3A4 inducer decreased the exposure of cabozantinib, which may reduce efficacy [see *Clinical Pharmacology (12.3)*]. Avoid coadministration of CABOMETYX with strong CYP3A4 inducers. Increase the dosage of CABOMETYX if coadministration with strong CYP3A4 inducers cannot be avoided [see *Dosage and Administration (2.6)*]. Avoid St. John's wort which may also decrease exposure of cabozantinib.

8 USE IN SPECIFIC POPULATIONS

8.1 Pregnancy

Risk Summary

Based on findings from animal studies and its mechanism of action [see *Clinical Pharmacology (12.1)*], CABOMETYX can cause fetal harm when administered to a pregnant woman. There are no available data in pregnant women to inform the drug-associated risk. In animal developmental and reproductive toxicology studies administration of cabozantinib to pregnant rats and rabbits during organogenesis resulted in embryofetal lethality and structural anomalies at exposures that were below those occurring clinically at the recommended dose (see *Data*). Advise pregnant women of the potential risk to a fetus.

In the U.S. general population, the estimated background risk of major birth defects and miscarriage in clinically recognized pregnancies is 2-4% and 15-20%, respectively.

Data

Animal Data

In an embryo-fetal development study in pregnant rats, daily oral administration of cabozantinib throughout organogenesis caused increased embryo-fetal lethality compared to controls at a dose of 0.03 mg/kg (approximately 0.12-fold of human area under the curve [AUC] at the recommended dose). Findings included delayed ossification and skeletal variations at a dose of 0.01 mg/kg/day (approximately 0.04-fold of human AUC at the recommended dose).

In pregnant rabbits, daily oral administration of cabozantinib throughout organogenesis resulted in findings of visceral malformations and variations including reduced spleen size and missing lung lobe at 3 mg/kg (approximately 1.1-fold of the human AUC at the recommended dose).

In a pre- and postnatal study in rats, cabozantinib was administered orally from gestation day 10 through postnatal day 20. Cabozantinib did not produce adverse maternal toxicity or affect pregnancy, parturition or lactation of female rats, and did not affect the survival, growth or postnatal development of the offspring at doses up to 0.3 mg/kg/day (0.05-fold of the maximum recommended clinical dose).

8.2 Lactation

Risk Summary

There is no information regarding the presence of cabozantinib or its metabolites in human milk, or their effects on the breastfed child or milk production. Because of the potential for serious adverse reactions in breastfed children, advise women not to breastfeed during treatment with CABOMETYX and for 4 months after the final dose.

8.3 Females and Males of Reproductive Potential

Pregnancy Testing

Verify the pregnancy status of females of reproductive potential prior to initiating CABOMETYX [see *Use in Specific Populations (8.1)*].

Contraception

CABOMETYX can cause fetal harm when administered to a pregnant woman [see *Use in Specific Populations (8.1)*].

Females

Advise females of reproductive potential to use effective contraception during treatment with CABOMETYX and for 4 months after the final dose.

Infertility

Females and Males

Based on findings in animals, CABOMETYX may impair fertility in females and males of reproductive potential [see *Nonclinical Toxicology (13.1)*].

8.4 Pediatric Use

The safety and effectiveness of CABOMETYX in pediatric patients have not been established.

Juvenile Animal Toxicity Data

Juvenile rats were administered cabozantinib at doses of 1 or 2 mg/kg/day from Postnatal Day 12 (comparable to less than 2 years in humans) through Postnatal Day 35 or 70. Mortalities occurred at doses ≥ 1 mg/kg/day (approximately 0.16 times the clinical dose of 60 mg/day based on body surface area). Hypoactivity was observed at both doses tested on Postnatal Day 22. Targets were generally similar to those seen in adult animals, occurred at both doses, and included the kidney (nephropathy, glomerulonephritis), reproductive organs, gastrointestinal tract (cystic dilatation and hyperplasia in Brunner's gland and inflammation of duodenum; and epithelial hyperplasia of colon and cecum), bone marrow (hypocellularity and lymphoid depletion), and liver. Tooth abnormalities and whitening as well as effects on bones including reduced bone mineral content and density, physal hypertrophy, and decreased cortical bone also occurred at all dose levels. Recovery was not assessed at a dose of 2 mg/kg (approximately 0.32 times the clinical dose of 60 mg based on body surface area) due to high levels of mortality. At the low dose level, effects on bone parameters were partially resolved but effects on the kidney and epididymis/testis persisted after treatment ceased.

8.5 Geriatric Use

In CABOSUN and METEOR, 41% of 409 patients treated with CABOMETYX were age 65 years and older, and 8% were 75 years and older. In CELESTIAL, 49% of 467 patients treated with CABOMETYX were age 65 years and older, and 15% were 75 years and older.

No overall differences in safety or effectiveness were observed between these patients and younger patients.

8.6 Hepatic Impairment

Increased exposure to cabozantinib has been observed in patients with moderate (Child-Pugh B) hepatic impairment. Reduce the CABOMETYX dose in patients with moderate hepatic impairment. Avoid CABOMETYX in patients with severe hepatic impairment (Child-Pugh C), since it has not been studied in this population [see *Dosage and Administration (2.7)*, *Clinical Pharmacology (12.3)*].

8.7 Renal Impairment

No dosage adjustment is recommended in patients with mild or moderate renal impairment. There is no experience with CABOMETYX in patients with severe renal impairment [see *Clinical Pharmacology (12.3)*].

10 OVERDOSAGE

One case of overdosage was reported following administration of another formulation of cabozantinib; a patient inadvertently took twice the intended dose for 9 days. The patient suffered Grade 3 memory impairment, Grade 3 mental status changes, Grade 3 cognitive disturbance, Grade 2 weight loss, and Grade 1 increase in BUN. The extent of recovery was not documented.

11 DESCRIPTION

CABOMETYX is the (*S*)-malate salt of cabozantinib, a kinase inhibitor. Cabozantinib (*S*)-malate is described chemically as *N*-(4-(6,7-dimethoxyquinolin-4-yloxy)phenyl)-*N'*-(4-fluorophenyl)cyclopropane-1,1-dicarboxamide, (2*S*)-hydroxybutanedioate. The molecular formula is $C_{28}H_{24}FN_3O_5 \cdot C_4H_6O_5$ and the molecular weight is 635.6 Daltons as malate salt. The chemical structure of cabozantinib (*S*)-malate salt is:

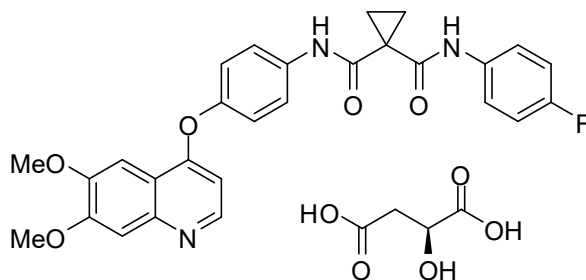

Cabozantinib (*S*)-malate salt is a white to off-white solid that is practically insoluble in aqueous media.

CABOMETYX (cabozantinib) tablets for oral use are supplied as film-coated tablets containing 20 mg, 40 mg, or 60 mg of cabozantinib, which is equivalent to 25 mg, 51 mg, or 76 mg of cabozantinib (*S*)-malate, respectively. CABOMETYX also contains the following inactive ingredients: microcrystalline cellulose, lactose anhydrous, hydroxypropyl cellulose, croscarmellose sodium, colloidal silicon dioxide, and magnesium stearate.

The film coating contains hypromellose, titanium dioxide, triacetin, and iron oxide yellow.

12 CLINICAL PHARMACOLOGY

12.1 Mechanism of Action

In vitro biochemical and/or cellular assays have shown that cabozantinib inhibits the tyrosine kinase activity of MET, VEGFR-1, -2 and -3, AXL, RET, ROS1, TYRO3, MER, KIT, TRKB, FLT-3, and TIE-2. These receptor tyrosine kinases are involved in both normal cellular function and pathologic processes such as oncogenesis, metastasis, tumor angiogenesis, drug resistance, and maintenance of the tumor microenvironment.

12.2 Pharmacodynamics

The exposure-response or –safety relationship for cabozantinib is unknown.

Cardiac Electrophysiology

The effect of cabozantinib on QTc interval was evaluated in a randomized, double-blinded, placebo-controlled trial in patients with medullary thyroid cancer administered a cabozantinib capsule formulation. A mean increase in QTcF of 10 - 15 ms was observed at 4 weeks after initiation. A concentration-QTc relationship could not be definitively established. Changes in cardiac wave form morphology or new rhythms were not observed. No patients in this study had a confirmed QTcF > 500 ms nor did any patients in METEOR, CABOSUN, or CELESTIAL.

12.3 Pharmacokinetics

Repeat daily dosing of a cabozantinib capsule formulation for 19 days resulted in 4- to 5-fold mean cabozantinib accumulation (based on AUC) compared to a single dose administration; steady state was achieved by Day 15.

Absorption

Median time to peak cabozantinib concentrations (T_{max}) ranged from 3 to 4 hours post-dose. A 19% increase in the C_{max} of CABOMETYX compared to a cabozantinib capsule formulation was observed following a single 140 mg dose. A less than 10% difference in the AUC was observed between CABOMETYX and a cabozantinib capsule formulation [*see Dosage and Administration (2.1)*].

Food Effect

Cabozantinib C_{\max} and AUC increased by 41% and 57%, respectively, following a high-fat meal relative to fasted conditions in healthy subjects administered a single oral dose of a cabozantinib capsule formulation.

Distribution

The oral volume of distribution (V_z/F) of cabozantinib is approximately 319 L. Cabozantinib is highly protein bound in human plasma ($\geq 99.7\%$).

Elimination

The predicted terminal half-life is approximately 99 hours and the clearance (CL/F) at steady-state is estimated to be 2.2 L/hr.

Metabolism

Cabozantinib is a substrate of CYP3A4 in vitro.

Excretion

Approximately 81% of the total administered radioactivity was recovered within a 48-day collection period following a single dose of radiolabeled ^{14}C -cabozantinib in healthy subjects. Approximately 54% was recovered in feces and 27% in urine. Unchanged cabozantinib accounted for 43% of the total radioactivity in feces and was not detectable in urine following a 72-hour collection.

Specific Populations

The following patient characteristics did not result in a clinically relevant difference in the pharmacokinetics of cabozantinib: age (32-86 years), sex, race (Whites and non-Whites), or mild to moderate renal impairment ($\text{eGFR} \geq 30 \text{ mL/min/1.73 m}^2$ as estimated by MDRD (modification of diet in renal disease equation)). The pharmacokinetics of cabozantinib is unknown in patients with $\text{eGFR} < 29 \text{ mL/min/1.73m}^2$ as estimated by MDRD equation or requiring dialysis.

Patients with Hepatic Impairment

Based on a population pharmacokinetic analysis of cabozantinib in healthy subjects and patients with cancer, no clinically significant differences in the mean cabozantinib exposure were observed between subjects with normal liver function (total bilirubin and $\text{AST} \leq \text{ULN}$) and those with mild hepatic impairment (total bilirubin $\leq \text{ULN}$ and $\text{AST} > \text{ULN}$ or total bilirubin > 1 to $1.5 \times \text{ULN}$ and any AST value). In a dedicated pharmacokinetic study, cabozantinib exposure ($\text{AUC}_{0-\text{INF}}$) increased by 63% in patients with moderate hepatic impairment (Child-Pugh B). Patients with severe hepatic impairment have not been studied [*see Dosage and Administration (2.7), Use in Specific Populations (8.6)*].

Drug Interaction Studies

Clinical Studies

CYP3A4 Inhibitors:

Administration of a strong CYP3A4 inhibitor, ketoconazole (400 mg daily for 27 days), with a cabozantinib capsule formulation to healthy subjects increased single-dose cabozantinib exposure (AUC_{0-1NF}) by 38%.

CYP3A4 Inducers:

Administration of a strong CYP3A4 inducer, rifampin (600 mg daily for 31 days), with a cabozantinib capsule formulation to healthy subjects decreased single-dose cabozantinib exposure (AUC_{0-1NF}) by 77%.

CYP2C8 Substrates:

No clinically-significant effect on single-dose rosiglitazone (a CYP2C8 substrate) exposure (C_{max} and AUC) was observed when co-administered with a cabozantinib capsule formulation at steady-state concentrations.

Gastric Acid Reducing Agents:

No clinically-significant effect on cabozantinib exposure (AUC) was observed following co-administration of the proton pump inhibitor (PPI) esomeprazole (40 mg daily for 6 days) with a single 100 mg dose of a cabozantinib capsule formulation to healthy subjects.

In vitro Studies

CYP Enzymes:

Inhibition of CYP3A4 reduced the formation of the oxidative metabolite by > 80%. Inhibition of CYP2C9 had a minimal effect on cabozantinib metabolite formation (i.e., a <20% reduction). Inhibition of CYP1A2, CYP2A6, CYP2B6, CYP2C8, CYP2C19, CYP2D6 and CYP2E1 had no effect on cabozantinib metabolite formation.

Although cabozantinib is an inhibitor of CYP2C8 in vitro, a clinical study of this potential interaction concluded that concurrent use did not result in a clinically relevant effect on CYP2C8 substrate exposure. Given this finding, other less sensitive substrates of pathways affected by cabozantinib in vitro (i.e., CYP2C9, CYP2C19, and CYP3A4) were not evaluated in a clinical study, because, although a clinically relevant exposure effect cannot be ruled out, it is unlikely. Cabozantinib does not inhibit CYP1A2 and CYP2D6 isozymes in vitro.

Cabozantinib is an inducer of CYP1A1 mRNA; however, the clinical relevance of this finding is unknown. Cabozantinib does not induce CYP1A2, CYP2B6, CYP2C8, CYP2C9, CYP2C19 or CYP3A4.

Transporters:

Cabozantinib is an inhibitor, but not a substrate, of P-gp transport activities and has the potential to increase concentrations of co-administered substrates of P-gp. The clinical relevance of this finding is unknown.

Cabozantinib is a substrate of MRP2 in vitro and MRP2 inhibitors have the potential to increase concentrations of cabozantinib. The clinical relevance of this finding is unknown.

13 NONCLINICAL TOXICOLOGY

13.1 Carcinogenesis, Mutagenesis, Impairment of Fertility

The carcinogenic potential of cabozantinib has been evaluated in two species: rasH2 transgenic mice and Sprague-Dawley rats. In the 2-year rat carcinogenicity study, once daily oral administration of cabozantinib resulted in a statistically significant increase in the incidence of malignant/complex malignant pheochromocytoma in combination with benign pheochromocytoma or in benign pheochromocytoma alone in male rats at a dose of 1 mg/kg (approximately 5 times the human exposure by AUC at the recommended 60 mg dose). Cabozantinib was not carcinogenic in a 26-week carcinogenicity study in rasH2 transgenic mice at a slightly higher exposure than the intended human therapeutic exposure.

Cabozantinib was not mutagenic *in vitro* in the bacterial reverse mutation (Ames) assay and was not clastogenic in both the *in vitro* cytogenetic assay using human lymphocytes or in the *in vivo* mouse micronucleus assay.

Based on nonclinical findings, male and female fertility may be impaired by treatment with CABOMETYX. In a fertility study in which cabozantinib was administered to male and female rats at doses of 1, 2.5, and 5 mg/kg/day, male fertility was significantly compromised at doses equal to or greater than 2.5 mg/kg/day (approximately 13-fold of human AUC at the recommended dose), with a decrease in sperm counts and reproductive organ weights. In females, fertility was significantly reduced at doses equal to or greater than 1 mg/kg/day (5-fold of human AUC at the recommended dose) with a significant decrease in the number of live embryos and a significant increase in pre- and post-implantation losses.

Observations of effects on reproductive tract tissues in general toxicology studies were supportive of effects noted in the dedicated fertility study and included hypospermia and absence of corpora lutea in male and female dogs in a 6-month repeat dose study at plasma exposures (AUC) approximately 0.5-fold (males) and <0.1-fold (females) of those expected in humans at the recommended dose. In addition, female rats administered 5 mg/kg/day for 14 days (approximately 9-fold of human AUC at the recommended dose) exhibited ovarian necrosis.

14 CLINICAL STUDIES

14.1 Renal Cell Carcinoma

Previously Treated with Anti-angiogenic Therapy

The efficacy of CABOMETYX was evaluated in METEOR (NCT01865747), a randomized (1:1), open-label, multicenter trial of CABOMETYX versus everolimus conducted in patients with advanced RCC who had received at least 1 prior anti-angiogenic therapy. Patients had to have a Karnofsky Performance Score (KPS) \geq 70%. Patients were stratified by the number of prior VEGFR tyrosine kinase inhibitors (TKIs) and Memorial Sloan Kettering Cancer Center (MSKCC) Risk Group.

Patients were randomized to receive CABOMETYX (N=330) 60 mg orally once daily or everolimus (N=328) 10 mg orally once daily. The majority of the patients were male (75%), with a median age of 62 years. Sixty-nine percent (69%) received only one prior anti-angiogenic

therapy. Patient distribution by MSKCC risk groups was 46% favorable (0 risk factors), 42% intermediate (1 risk factor), and 13% poor (2 or 3 risk factors). Fifty-four percent (54%) of patients had 3 or more organs with metastatic disease, including lung (63%), lymph nodes (62%), liver (29%), and bone (22%).

The main efficacy outcome measure was progression-free survival (PFS) assessed by a blinded independent radiology review committee among the first 375 subjects randomized. Other efficacy endpoints were objective response rate (ORR) and overall survival (OS) in the Intent-to-Treat (ITT) population. Tumor assessments were conducted every 8 weeks for the first 12 months, then every 12 weeks thereafter. Patients received treatment until disease progression or experiencing unacceptable toxicity. Patients on both arms who had disease progression could continue treatment at the discretion of the investigator.

Statistically significant improvements in PFS, OS, and ORR were demonstrated for CABOMETYX compared to everolimus. Efficacy results are presented in Tables 6 and 7 and Figures 1 and 2.

Table 6: Efficacy Results in METEOR (First 375 Randomized)

Endpoint	CABOMETYX	Everolimus
	N = 187	N = 188
Median PFS (95% CI), months	7.4 (5.6, 9.1)	3.8 (3.7, 5.4)
HR (95% CI), p-value ¹	0.58 (0.45, 0.74), p<0.0001	

¹ stratified log-rank test with prior VEGFR-targeting TKI therapy (1 vs 2 or more) and MSKCC prognostic criteria for previously treated patients with RCC (0 vs 1 vs 2 or 3) as stratification factors (per IVRS data)

Figure 1: Kaplan-Meier Curves of Progression-Free Survival in METEOR (First 375 Randomized)

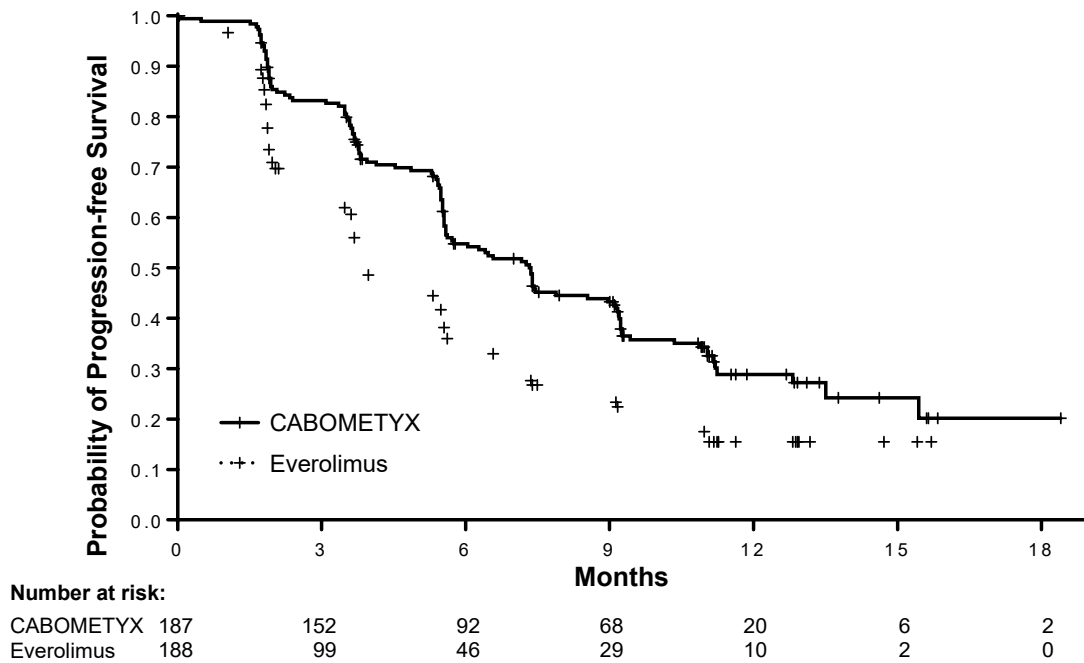

Table 7: Efficacy Results in METEOR (ITT)

Endpoint	CABOMETYX	Everolimus
	N = 330	N = 328
Median OS (95% CI), months	21.4 (18.7, NE)	16.5 (14.7, 18.8)
HR (95% CI), p-value ¹	0.66 (0.53, 0.83), p=0.0003	
Confirmed ORR (partial responses only) (95% CI)	17% (13%, 22%)	3% (2%, 6%)
p-value ²	p<0.0001	

¹ stratified log-rank test with prior VEGFR-targeting TKI therapy (1 vs 2 or more) and MSKCC prognostic criteria for previously treated patients with RCC (0 vs 1 vs 2 or 3) as stratification factors (per IVRS data)

² chi-squared test

Figure 2: Kaplan-Meier Curve of Overall Survival in METEOR (ITT)

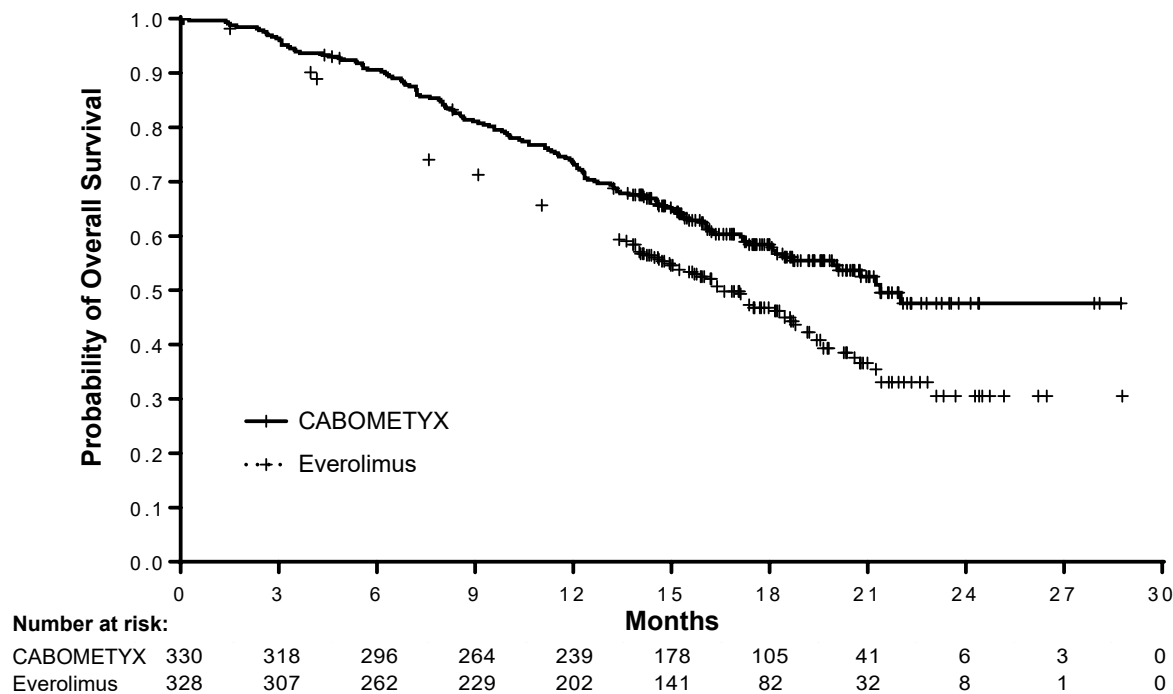

First-line Treatment

The efficacy of CABOMETYX was evaluated in CABOSUN (NCT01835158), a randomized (1:1), open-label, multicenter trial of CABOMETYX versus sunitinib conducted in patients with advanced RCC who had not received prior therapy. Patients were randomized to receive CABOMETYX (N=79) 60 mg orally once daily or sunitinib (N=78) 50 mg orally once daily (4 weeks on treatment followed by 2 weeks off) until disease progression or unacceptable toxicity. All patients were required to have intermediate or poor risk disease as defined by the International Metastatic RCC Database Consortium (IMDC) risk group categories. Patients were stratified by IMDC risk group and presence of bone metastases (yes/no).

The majority of patients were male (78%), with a median age of 63 years. Patient distribution by IMDC risk groups was 81% intermediate (1-2 risk factors) and 19% poor (≥ 3 risk factors). Thirty-six percent (36%) patients had bone metastases. Forty-six percent (46%) of patients were ECOG 0, 41% ECOG 1, and 13% ECOG 2.

The major efficacy outcome measure was progression-free survival (PFS) by a retrospective blinded independent radiology review committee (BIRC).

A statistically significant improvement in PFS, as assessed by a blinded independent radiology review committee, was demonstrated for CABOMETYX compared to sunitinib. Efficacy results are presented in Table 8, Figure 3, and Figure 4.

Table 8: Efficacy Results in CABOSUN

Endpoint	CABOMETYX	Sunitinib
	N = 79	N = 78
Progression-Free Survival¹		
Events, n(%)	43 (54)	49 (63)
Median PFS (95% CI), months ¹	8.6 (6.8, 14.0)	5.3 (3.0, 8.2)
Hazard Ratio ² (95% CI), p-value ³	0.48 (0.31, 0.74), p=0.0008	
Overall Survival		
Events, n(%)	43 (54)	47 (60)
Hazard Ratio ^{2,4} (95% CI)	0.80 (0.53, 1.21)	
Confirmed ORR, partial responses only (95% CI)^{1,4}	20% (12.0, 30.8)	9% (3.7, 17.6)

¹ as assessed by a retrospective blinded independent radiology review committee (BIRC)

² estimated from stratified Cox proportional hazards model with stratification factors IMDC risk group and presence of bone metastases and treatment as covariate

³ two-sided stratified log-rank test with stratification factors IMDC risk group and presence of bone metastases

⁴ no multiplicity adjustments were made for overall survival or ORR

Figure 3: Kaplan-Meier Curve of Progression-Free Survival in CABOSUN

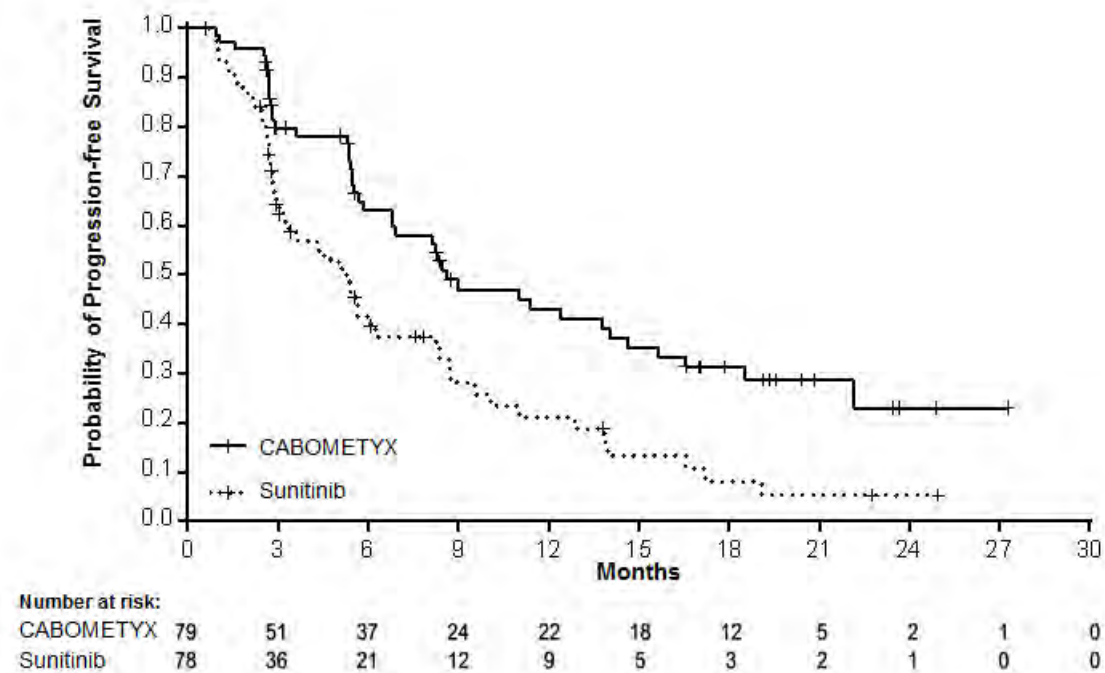
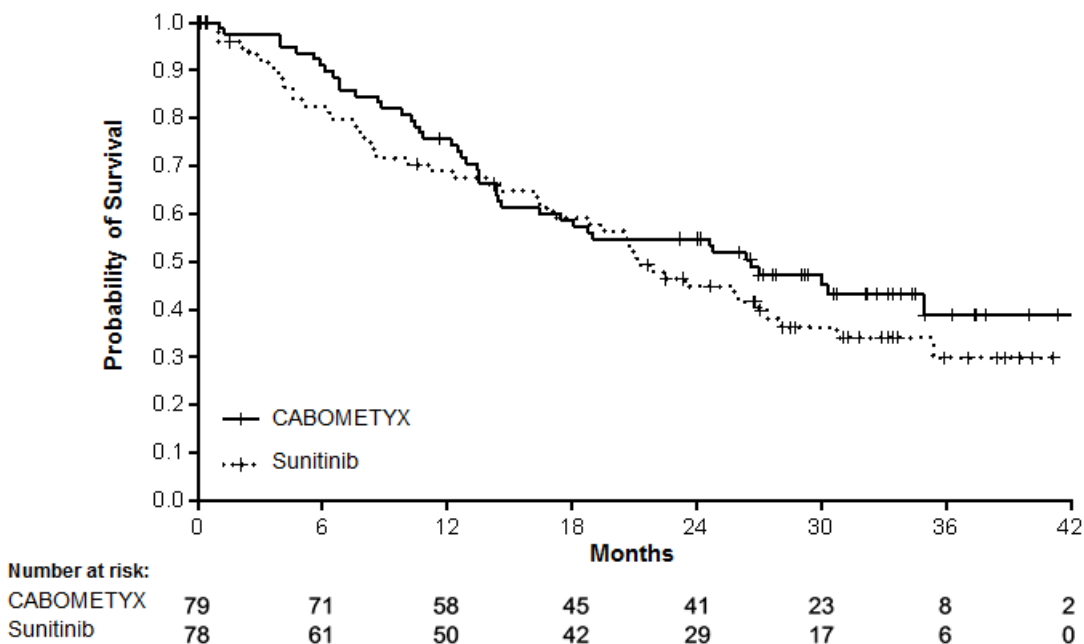

Figure 4: Kaplan-Meier Curve of Overall Survival in CABOSUN



14.2 Hepatocellular Carcinoma

The efficacy of CABOMETRYX was evaluated in CELESTIAL (NCT01908426), a randomized (2:1), double-blind, placebo-controlled, multicenter trial in patients with hepatocellular carcinoma (HCC) who had previously received sorafenib and had Child Pugh Class A liver impairment. Patients were randomized to receive CABOMETRYX 60 mg orally once daily or placebo until disease progression or unacceptable toxicity. Randomization was stratified by etiology of disease (hepatitis B virus [HBV] with or without hepatitis C virus [HCV] vs. HCV [without HBV] vs. other [without HBV and HCV]), geographic region (Asia vs. other regions), and presence of extrahepatic spread of disease and/or macrovascular invasion (yes vs. no). The primary efficacy outcome measure was overall survival (OS). Additional outcome measures were progression-free survival (PFS) and objective response rate (ORR), as assessed by investigators per RECIST 1.1. Tumor assessments were conducted every 8 weeks.

In CELESTIAL, a total of 707 patients were randomized, 470 to CABOMETRYX and 237 to placebo. The median age was 64 years (range 22 to 86 years), 82% were male, 56% were White and 34% were Asian. Baseline ECOG performance status was 0 (53%) or 1 (47%). The etiology of HCC was attributed to HBV in 38% of patients and HCV in 21%; etiology was attributed to causes other than HBV or HCV in 40%. Macroscopic vascular invasion or extra-hepatic tumor spread was present in 78% of patients and 41% had alpha-fetoprotein (AFP) levels ≥ 400 mcg/L. All patients received prior sorafenib and 27% received two prior systemic therapy regimens.

Efficacy results are summarized in Table 9, Figure 5, and Figure 6.

Table 9: Efficacy Results from CELESTIAL

Endpoint	CABOMETYX	Placebo
	N = 470	N = 237
Overall Survival		
Number of Deaths, (%)	317 (67)	167 (70)
Median OS in Months (95% CI)	10.2 (9.1, 12.0)	8.0 (6.8, 9.4)
Hazard Ratio (95% CI) ¹	0.76 (0.63, 0.92)	
p-value ²	p=0.0049 ³	
Progression-Free Survival		
Number of Events, (%)	349 (74)	205 (86)
Progressive Disease	284 (60)	186 (78)
Death	65 (14)	19 (8)
Median PFS in Months (95% CI)	5.2 (4.0, 5.5)	1.9 (1.9, 1.9)
Hazard Ratio (95% CI) ¹	0.44 (0.36, 0.52)	
p-value ²	p< 0.0001	
Overall Response Rate (ORR)		
Confirmed ORR (partial responses only) (95% CI) ³	4% (2.3, 6.0)	0.4% (0.0, 2.3)
p-value ⁴	p=0.0086	

CI, confidence interval

¹ estimated using the Cox proportional-hazard model

² log-rank test stratified by etiology of disease (HBV [with or without HCV], HCV [without HBV], or Other), geographic region (Asia, Other Regions), and presence of extrahepatic spread of disease and/or macrovascular invasion (Yes, No) as stratification factors (per IVRS data)

³ significance level = 0.021 for 78% information (484 deaths) based on O'Brien-Fleming method

⁴ Fisher's exact test

Figure 5: Kaplan-Meier Curve of Overall Survival in CELESTIAL

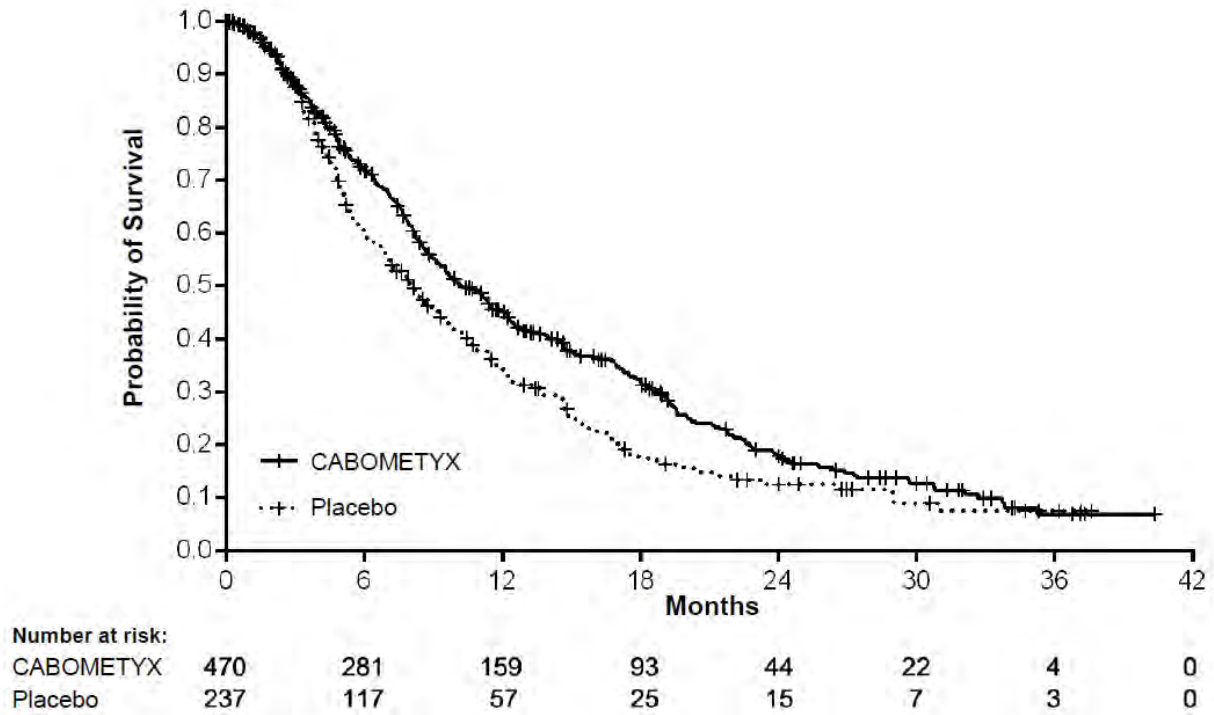
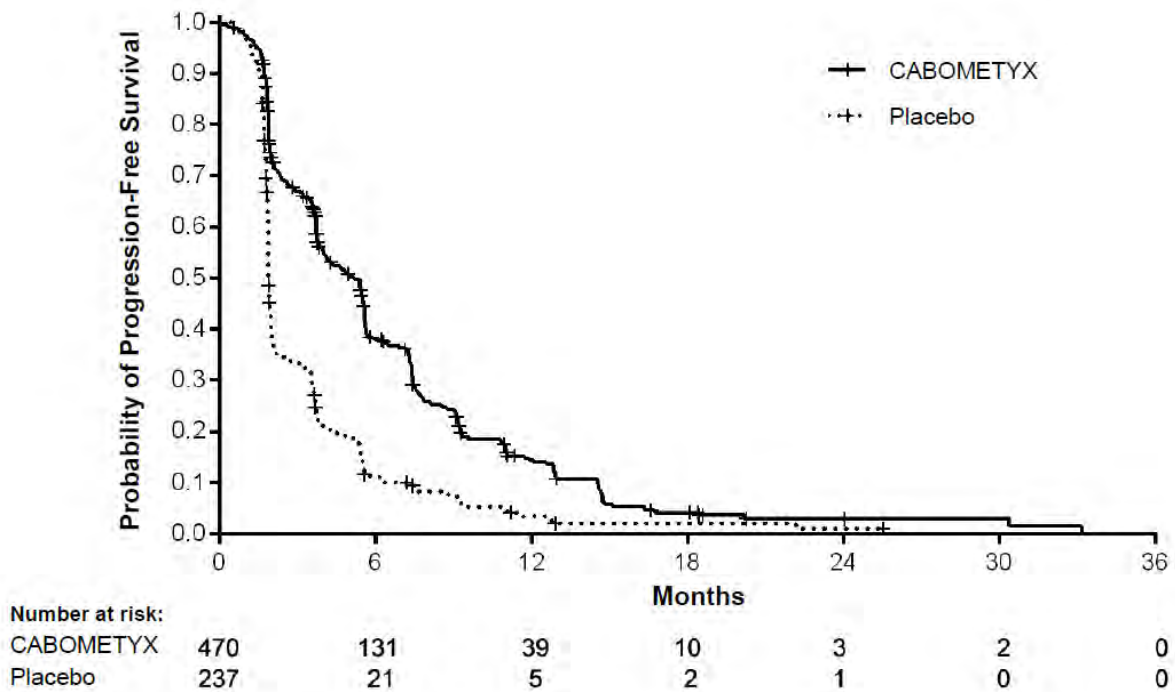

Figure 6: Kaplan-Meier Curve of Progression-Free Survival in CELESTIAL



16 HOW SUPPLIED/STORAGE AND HANDLING

CABOMETYX tablets are supplied as follows:

60 mg tablets are yellow film-coated, oval shaped with no score, debossed with “XL” on one side and “60” on the other side of the tablet; available in bottles of 30 tablets:

NDC 42388-023-26

40 mg tablets are yellow film-coated, triangle shaped with no score, debossed with “XL” on one side and “40” on the other side of the tablet; available in bottles of 30 tablets:

NDC 42388-025-26

20 mg tablets are yellow film-coated, round shaped with no score, debossed with “XL” on one side and “20” on the other side of the tablet; available in bottles of 30 tablets:

NDC 42388-024-26

Store CABOMETYX at 20°C to 25°C (68°F to 77°F); excursions are permitted from 15°C to 30°C (59°F to 86°F) [see USP Controlled Room Temperature].

17 PATIENT COUNSELING INFORMATION

Advise the patient to read the FDA-approved patient labeling (Patient Information).

- **Hemorrhage:** Instruct patients to contact their healthcare provider to seek immediate medical attention for signs or symptoms of unusual severe bleeding or hemorrhage [see *Warnings and Precautions (5.1)*].
- **Perforations and fistulas:** Advise patients that gastrointestinal disorders such as diarrhea, nausea, vomiting, and constipation may develop during CABOMETYX treatment and to seek immediate medical attention if they experience persistent or severe abdominal pain because cases of gastrointestinal perforation and fistula have been reported in patients taking CABOMETYX [see *Warnings and Precautions (5.2)*].
- **Thrombotic events:** Venous and arterial thrombotic events have been reported. Advise patients to report signs or symptoms of an arterial thrombosis. Venous thromboembolic events including pulmonary embolus have been reported. Advise patients to contact their health care provider if new onset of dyspnea, chest pain, or localized limb edema occurs [see *Warnings and Precautions (5.3)*].
- **Hypertension and hypertensive crisis:** Inform patients of the signs and symptoms of hypertension. Advise patients to undergo routine blood pressure monitoring and to contact their health care provider if blood pressure is elevated or if they experience signs or symptoms of hypertension [see *Warnings and Precautions (5.4)*].
- **Diarrhea:** Advise patients to notify their healthcare provider at the first signs of poorly formed or loose stool or an increased frequency of bowel movements [see *Warnings and Precautions (5.5)*].
- **Palmar-plantar erythrodysesthesia:** Advise patients to contact their healthcare provider for progressive or intolerable rash [see *Warnings and Precautions (5.6)*].

- Osteonecrosis of the jaw: Advise patients regarding good oral hygiene practices. Advise patients to immediately contact their healthcare provider for signs or symptoms associated with osteonecrosis of the jaw [see *Warnings and Precautions (5.8)*].
- Impaired wound healing: Advise patients that CABOMETYX may impair wound healing. Advise patients to inform their healthcare provider of any planned surgical procedure [see *Dosage and Administration (2.1), Warnings and Precautions (5.9)*].
- Reversible posterior leukoencephalopathy syndrome: Advise patients to immediately contact their health care provider for new onset or worsening neurological function [see *Warnings and Precautions (5.10)*].
- Embryo-fetal toxicity:
 - Advise females of reproductive potential of the potential risk to a fetus. Advise females to inform their healthcare provider of a known or suspected pregnancy [see *Warnings and Precautions (5.11), Use in Specific Populations (8.1)*].
 - Advise females of reproductive potential to use effective contraception during treatment with CABOMETYX and for 4 months after the final dose [see *Use in Specific Populations (8.3)*].
- Lactation: Advise women not to breastfeed during treatment with CABOMETYX and for 4 months following the last dose [see *Use in Specific Populations (8.2)*].
- Drug interactions: Advise patients to inform their healthcare provider of all prescription or nonprescription medications, vitamins or herbal products. Inform patients to avoid grapefruit, grapefruit juice, and St. John's wort [see *Drug Interactions (7.1)*].

Important administration information

- Instruct patients to take CABOMETYX at least 1 hour before or at least 2 hours after eating.

Manufactured for Exelixis, Inc. Alameda, CA 94502

PATIENT INFORMATION
CABOMETYX® (Ka-boe-met-iks)
cabozantinib
tablets

What is CABOMETYX?

CABOMETYX is a prescription medicine used to treat people with:

- advanced kidney cancer (renal cell carcinoma)
- liver cancer (hepatocellular carcinoma) who have been previously treated with the medicine sorafenib.

It is not known if CABOMETYX is safe and effective in children.

Before you take CABOMETYX, tell your healthcare provider about all of your medical conditions, including if you:

- have a recent history of bleeding, including coughing up or vomiting blood, or black tarry stools.
- have an open or healing wound
- have high blood pressure
- plan to have any surgery, dental procedure, or have had a recent surgery. You should stop taking CABOMETYX at least 3 weeks before planned surgery. See **“What are the possible side effects of CABOMETYX?”**
- are pregnant, or plan to become pregnant. CABOMETYX can harm your unborn baby.
 - If you are able to become pregnant, your healthcare provider will check your pregnancy status before you start treatment with CABOMETYX.
 - Females who are able to become pregnant should use effective birth control (contraception) during treatment and for 4 months after your final dose of CABOMETYX.
 - Talk to your healthcare provider about birth control methods that may be right for you.
 - If you become pregnant or think you are pregnant, tell your healthcare provider right away.
- are breastfeeding or plan to breastfeed. It is not known if CABOMETYX passes into your breast milk. Do not breastfeed during treatment and for 4 months after your final dose of CABOMETYX.

Tell your healthcare provider about all the medicines you take, including prescription or over-the-counter medicines, vitamins, and herbal supplements. CABOMETYX and certain other medicines may affect each other causing side effects.

How should I take CABOMETYX?

- Take CABOMETYX exactly as your healthcare provider tells you to take it.
- **Do not** take CABOMETYX with food. Take CABOMETYX at least 1 hour before or at least 2 hours after eating.
- Swallow CABOMETYX tablets whole with a full glass (at least 8 ounces) of water.
- **Do not** crush CABOMETYX tablets.
- If you miss a dose and your next dose is in:
 - less than 12 hours, take your next dose at the normal time. Do not make up the missed dose.
 - 12 hours or more, take the missed dose as soon as you remember. Take your next dose at the normal time.

What should I avoid while taking CABOMETYX?

Do not drink grapefruit juice, eat grapefruit or take supplements that contain grapefruit or St. John’s wort during treatment with CABOMETYX.

What are the possible side effects of CABOMETYX?

CABOMETYX may cause serious side effects, including:

- **bleeding (hemorrhage).** CABOMETYX can cause severe bleeding that may lead to death. Tell your healthcare provider right away if you get any signs of bleeding during treatment with CABOMETYX, including:
 - coughing up blood or blood clots
 - red or black (looks like tar) stools

- vomiting blood or if your vomit looks like coffee-grounds
 - menstrual bleeding that is heavier than normal
 - any unusual or heavy bleeding
 - **a tear in your stomach or intestinal wall (perforation) or an abnormal connection between 2 parts of your body (fistula).** Tell your healthcare provider right away if you get tenderness or pain in your stomach-area (abdomen).
 - **blood clots, stroke, heart attack, and chest pain.** Get emergency help right away if you get:
 - swelling or pain in your arms or legs
 - sudden confusion, trouble speaking or understanding
 - shortness of breath
 - sudden trouble seeing in one or both eyes
 - feel lightheaded or faint
 - sudden trouble walking
 - sweating more than usual
 - dizziness, loss of balance or coordination
 - numbness or weakness of your face, arm or leg, especially on one side of your body
 - a sudden severe headache
 - **high blood pressure (hypertension).** Hypertension is common with CABOMETYX and sometimes can be severe. Your healthcare provider will check your blood pressure before starting CABOMETYX and during treatment with CABOMETYX. If needed, your healthcare provider may prescribe medicine to treat your high blood pressure.
 - **diarrhea.** Diarrhea is common with CABOMETYX and can be severe. If needed, your healthcare provider may prescribe medicine to treat your diarrhea. Tell your healthcare provider right away, if you have frequent loose, watery bowel movements.
 - **a skin problem called hand-foot skin reaction.** Hand-foot skin reactions are common and can be severe. Tell your healthcare provider right away if you have rashes, redness, pain, swelling, or blisters on the palms of your hands or soles of your feet.
 - **protein in your urine and possible kidney problems.** Symptoms may include swelling in your hands, arms, legs, or feet.
 - **severe jaw bone problems (osteonecrosis).** Symptoms may include jaw pain, toothache, or sores on your gums. Your healthcare provider should examine your mouth before you start and during treatment with CABOMETYX. Tell your dentist that you are taking CABOMETYX. It is important for you to practice good mouth care during treatment with CABOMETYX.
 - **wound healing problems.** Wound healing problems have happened in some people who take CABOMETYX. Tell your healthcare provider if you plan to have any surgery before or during treatment with CABOMETYX.
 - You should stop taking CABOMETYX at least 3 weeks before planned surgery.
 - Your healthcare provider should tell you when you may start taking CABOMETYX again after surgery.
 - **Reversible Posterior Leukoencephalopathy Syndrome (RPLS).** A condition called reversible posterior leukoencephalopathy syndrome can happen during treatment with CABOMETYX. Tell your healthcare provider right away if you have headaches, seizures, confusion, changes in vision, or problems thinking.
 - CABOMETYX may cause fertility problems in females and males, which may affect your ability to have children. Talk to your healthcare provider if you have concerns about fertility.
- Your healthcare provider may change your dose, temporarily stop, or permanently stop treatment with CABOMETYX if you have certain side effects.
- The most common side effects of CABOMETYX include:
- tiredness
 - decreased appetite
 - weight loss
 - nausea
 - vomiting
 - changes in certain blood tests
- Tell your healthcare provider if you have any side effect that bothers you or that does not go away. These are not all of the possible side effects of CABOMETYX. Call your doctor for medical advice about side effects. You may report side effects to FDA at 1-800-FDA-1088.

How should I store CABOMETYX?

- Store CABOMETYX at room temperature 68°F to 77°F (20°C to 25°C).

Keep CABOMETYX and all medicines out of the reach of children.

General information about the safe and effective use of CABOMETYX.

Medicines are sometimes prescribed for purposes other than those listed in a Patient Information leaflet. Do not use CABOMETYX for a condition for which it was not prescribed. Do not give CABOMETYX to other people, even if they have the same symptoms you have. It may harm them.

You can ask your healthcare provider or pharmacist for information about CABOMETYX that is written for health professionals.

What are the ingredients in CABOMETYX?

Active ingredient: cabozantinib

Inactive ingredients: microcrystalline cellulose, lactose anhydrous, hydroxypropyl cellulose, croscarmellose sodium, colloidal silicon dioxide, and magnesium stearate. The film coating contains hypromellose, titanium dioxide, triacetin, and iron oxide yellow.

Manufactured for Exelixis, Inc. Alameda, CA 94502

For more information, go to www.cabometryx.com or call 1-855-292-3935.

This Patient Information has been approved by the U.S. Food and Drug Administration. Issued: 01/2020

PRODUCT MONOGRAPH

Pr **CHAMPIX**[®]

(varenicline tartrate tablets)

0.5 mg and 1.0 mg varenicline (as varenicline tartrate)

Smoking-Cessation Aid

Pfizer Canada Inc.
17,300 Trans-Canada Highway
Kirkland, Quebec H9J 2M5

Date of Revision:
January 22, 2019

® C.P. Pharmaceuticals International C.V.
Pfizer Canada Inc., licensee

© 2019 Pfizer Canada ULC

Submission Control No: 221214

Table of Contents

PART I: HEALTH PROFESSIONAL INFORMATION.....3
SUMMARY PRODUCT INFORMATION3
INDICATIONS AND CLINICAL USE.....3
CONTRAINDICATIONS3
WARNINGS AND PRECAUTIONS.....3
ADVERSE REACTIONS.....12
DRUG INTERACTIONS24
DOSAGE AND ADMINISTRATION.....27
OVERDOSAGE29
ACTION AND CLINICAL PHARMACOLOGY30
INDICATIONS AND CLINICAL USE.....32
STORAGE AND STABILITY.....40
DOSAGE FORMS, COMPOSITION AND PACKAGING40

PART II: SCIENTIFIC INFORMATION41
PHARMACEUTICAL INFORMATION.....41
CLINICAL TRIALS.....42
DETAILED PHARMACOLOGY47
TOXICOLOGY48
REFERENCES51

PART III: CONSUMER INFORMATION.....54

CHAMPIX[®]
(varenicline tartrate tablets)

PART I: HEALTH PROFESSIONAL INFORMATION

SUMMARY PRODUCT INFORMATION

Route of Administration	Dosage Form / Strength	All Non-medicinal Ingredients
oral	Tablet: 0.5 mg and 1.0 mg	Anhydrous dibasic calcium phosphate, colloidal silicon dioxide, croscarmellose sodium, magnesium stearate, and microcrystalline cellulose. The film-coating contains hypromellose, polyethylene glycol, titanium dioxide and triacetin. The 1.0 mg tablet also contains FD&C Blue #2/Indigo Carmine Aluminum Lake as a colouring agent.

INDICATIONS AND CLINICAL USE

Adults

CHAMPIX (varenicline tartrate) is indicated for smoking-cessation treatment in adults, in conjunction with smoking-cessation counselling.

Geriatrics (>65 years of age): No dosage adjustment is necessary for healthy elderly patients. However, varenicline is known to be substantially excreted by the kidney, and the risk of toxic reactions to this drug may be greater in patients with impaired renal function. Because elderly patients are more likely to have decreased renal function, care should be taken in dose selection, and it may be useful to monitor renal function (see **WARNINGS AND PRECAUTIONS, Special Populations: Geriatrics**).

Pediatrics (<18 years of age): Based on the data submitted and reviewed by Health Canada, the safety and efficacy of CHAMPIX in pediatric patients has not been established; therefore, Health Canada has not authorized an indication for pediatric use (see **WARNINGS AND PRECAUTIONS, Special Populations: Pediatrics**).

CONTRAINDICATIONS

Patients who are hypersensitive to varenicline or to any ingredient in the formulation or component of the container.

WARNINGS AND PRECAUTIONS

Psychiatric Symptoms (in Patients with and without Pre-existing Psychiatric Disorder or Symptoms) (see also **ADVERSE REACTIONS, Post-Marketing Experience**)

There have been post-marketing reports of serious neuropsychiatric symptoms in patients being treated with CHAMPIX, including anxiety, psychosis, mood swings, depressed mood, agitation, aggression, hostility, changes in behavior or thinking, suicidal ideation, suicidal behavior and suicide, as well as worsening of pre-existing psychiatric disorder (previously diagnosed or not). Not all patients had stopped smoking at the time of onset of symptoms, and not all patients had known pre-existing psychiatric illness, or were using concomitant CNS drugs.

Randomized Study Data: A large randomized, double-blind, active and placebo-controlled study (“EAGLES” study) was conducted to compare the risk of serious neuropsychiatric events in patients with and without a history of psychiatric disorder treated for smoking cessation with varenicline, bupropion, nicotine replacement therapy patch (NRT) or placebo. The primary safety endpoint was a composite of neuropsychiatric adverse events that have been reported in post-marketing experience. The findings were that the use of CHAMPIX, in patients with or without a history of psychiatric disorder, was not associated with an increased risk of serious neuropsychiatric adverse events in the composite primary endpoint compared with placebo (See **ACTION AND CLINICAL PHARMACOLOGY, Special Populations and Conditions, Neuropsychiatric Safety Study in Subjects with and without a History of Psychiatric Disorder**).

Recommendations: Clinicians should be aware of the possible emergence of serious neuropsychiatric symptoms in patients attempting to quit smoking, with or without treatment.

Alcohol intake: There have been post-marketing reports of patients experiencing increased intoxicating effects of alcohol while taking CHAMPIX. Some cases described unusual and sometimes aggressive behaviour, and were often accompanied by amnesia for the events.

Pre-existing Psychiatric Disorder or Symptoms: Smoking cessation, with or without pharmacotherapy, has been associated with exacerbation of underlying psychiatric illness (e.g. depression, anxiety). Patients with a history of psychiatric symptoms should be monitored for worsening or new symptoms when attempting to quit smoking, regardless of how well controlled symptoms may be when starting smoking cessation treatment. Patients should be instructed to report strongly atypical and concerning symptoms to their healthcare provider, so that dose adjustments of psychiatric medications or CHAMPIX may be considered.

General: Patients should be informed that if they experience thoughts, moods or behaviours that are strongly atypical and concerning while on smoking-cessation medication, including CHAMPIX, the medication should be discontinued immediately, with urgent medical help sought as needed, and the symptoms reported to their healthcare provider.

Angioedema and Hypersensitivity reactions

There have been post-marketing reports of hypersensitivity reactions, including angioedema, in patients treated with CHAMPIX (see **ADVERSE REACTIONS, Post-Marketing Experience**). Clinical signs included swelling of the face, mouth (tongue, lips and gums), neck (pharynx and larynx) and extremities. There were rare reports of life-threatening angioedema requiring urgent medical attention due to respiratory compromise. Patients experiencing these symptoms should

be instructed to discontinue treatment with CHAMPIX and contact a healthcare provider immediately.

Serious Skin Reactions

There have also been post-marketing reports of rare but severe cutaneous reactions, including Stevens-Johnson syndrome and erythema multiforme, in patients using CHAMPIX (see **ADVERSE REACTIONS, Post-Marketing Experience**). As these skin reactions can be life-threatening, patients should be instructed to discontinue treatment at the first sign of rash or skin reaction and contact a healthcare provider immediately.

Seizures

In clinical trials and post-marketing experience there have been reports of seizures in patients treated with CHAMPIX. Some patients had no history of seizures, whereas others had a history of seizure disorder that was remote or well-controlled. CHAMPIX should be used cautiously in patients with a history of seizures or other conditions that potentially lower the seizure threshold. Advise patients to discontinue CHAMPIX and immediately contact a healthcare provider if they experience a seizure while on treatment (see **Special Populations, Use of CHAMPIX in Patients with Concomitant Conditions**).

Somnambulism

Cases of somnambulism have been reported post-marketing in patients taking CHAMPIX. Some cases described harmful behavior to self, others, or property. Instruct patients to discontinue CHAMPIX and notify their healthcare provider if they experience somnambulism.

Cardiovascular Events

In a placebo-controlled smoking cessation clinical trial in patients with stable cardiovascular disease (CVD), patients were treated with CHAMPIX 1 mg BID or placebo for 12 weeks, and then followed for another 40 weeks. There were approximately 350 patients per arm. Serious cardiovascular (CV) events that were reported more frequently in CHAMPIX compared to placebo (difference > 2 subjects) were: non-fatal myocardial infarctions (4 vs. 1, on-treatment phase) and need for coronary revascularization (7 vs. 2, post-treatment phase). The total number of patients that experienced serious CV events in CHAMPIX compared to placebo was: 10 vs. 9 on treatment phase, 16 vs. 11 post-treatment phase, for a total of 25 vs. 20 over the 52 week duration. The serious CV events occurring during the treatment and post-treatment phases were adjudicated by an independent blinded committee.

The study was powered for assessing efficacy (ie quit rates) but not for assessing differences in the occurrence of serious CV events between CHAMPIX and placebo. Therefore, the study was not large enough to allow conclusions regarding the difference in the incidence of CV events reported in the two arms (See also **ADVERSE EVENTS, Clinical Trial in Special Populations**; and **ACTION AND CLINICAL PHARMACOLOGY, Special Population**). Physicians are to inform patients of the symptoms of a heart attack and stroke, and instruct them to get emergency medical help right away if they experience any of these symptoms (see also **Patient Counselling Information**).

The CV safety of CHAMPIX was also evaluated in the Cardiovascular Safety Assessment Study in subjects with and without a history of psychiatric disorder that randomized subjects 1:1:1:1 to CHAMPIX 1 mg BID, bupropion SR 150 mg BID, nicotine replacement therapy patch (NRT) 21 mg/day with taper or placebo for a treatment period of 12 weeks. Subjects were then followed post-treatment through a period of up to a total of 52 weeks (See ACTION AND CLINICAL PHARMACOLOGY, Special Populations and Conditions, Cardiovascular Safety Assessment Study in Subjects with and without a History of Psychiatric Disease). Major CV events (CV death, non-fatal MI, non-fatal stroke) were infrequent overall (1/2016 and 4/2014, for patients treated with CHAMPIX and placebo, respectively) during the treatment period. However, because of the relatively low number of events overall and the lack of power for assessing differences between CHAMPIX and placebo, an association between the use of CHAMPIX and an increased risk of CV adverse events cannot be entirely ruled out.

CHAMPIX has not been studied in patients with unstable cardiovascular disease or those with cardiovascular events occurring within two months before study screening. Patients should be advised to notify a health care provider of new or worsening symptoms of cardiovascular disease. The risks of CHAMPIX should be weighed against the benefits of its use in smokers with cardiovascular disease. Smoking is an independent and major risk factor for cardiovascular disease. CHAMPIX has been demonstrated to increase the likelihood of abstinence from smoking for as long as one year compared to treatment with placebo.

Accidental Injury, including while Driving, Operating Machinery

There have been post-marketing reports of traffic accidents, near-miss incidents in traffic, and other accidental injuries in patients taking CHAMPIX. In some cases, the patients reported somnolence, dizziness, loss of consciousness (blackouts), seizures or difficulty concentrating.

Therefore, patients should be advised not to engage in potentially hazardous activities, such as driving a car or operating dangerous machines, until they know how CHAMPIX may affect them.

Concomitant Illness The full consequences of using this product in patients with concomitant illness have not been studied, and caution should be exercised (see **Special Populations, Use of CHAMPIX in Patients with Concomitant Conditions**).

Nicotine replacement therapy (NRT)

The concomitant use of NRT with CHAMPIX (varenicline tartrate) may result in an increase in adverse reactions. In a clinical drug interaction study (N=24), the incidences of nausea, headache, vomiting, dizziness, dyspepsia and fatigue were greater for the combination of NRT and varenicline than for NRT alone (see DRUG INTERACTIONS). The safety and efficacy of the combination treatment with CHAMPIX and NRT have not been studied. Due to the proposed mechanism of action of varenicline, it is not anticipated that co-administration with NRT would confer additional benefit compared with CHAMPIX alone.

Effect of smoking-cessation

Physiological changes resulting from smoking-cessation, with or without treatment with CHAMPIX, may alter the pharmacokinetics or pharmacodynamics of some drugs for which dosage adjustment may be necessary (examples include theophylline, warfarin and insulin). As smoking induces cytochrome P450 (CYP) isoenzyme 1A2, smoking-cessation may result in an increase of plasma levels of CYP1A2 substrates.

Nausea

Nausea was the most common adverse event associated with CHAMPIX treatment. Nausea was generally described as mild or moderate and often transient; however, for some subjects, it was persistent over several months. The incidence of nausea was dose-dependent. Initial dose-titration was beneficial in reducing the occurrence of nausea. Nausea was reported by approximately 30% of patients treated with CHAMPIX 1.0 mg BID after an initial week of dose titration. In patients taking CHAMPIX 0.5 mg BID, the incidence of nausea was 16% following initial titration. Approximately 3% of subjects treated with CHAMPIX 1.0 mg BID in studies involving 12 weeks of treatment discontinued treatment prematurely because of nausea. For patients with intolerable nausea, dose reduction should be considered (see **DOSAGE AND ADMINISTRATION, Recommended Dose and Dosage Adjustment**).

Carcinogenesis and Mutagenesis

For animal data, see **Part II: TOXICOLOGY** section.

Dependence/Tolerance

Animal Studies

The subjective nicotine-like effects of varenicline were investigated in drug discrimination studies. At 1.0 mg/kg, there was complete substitution of varenicline for nicotine in a paradigm of nicotine-associated lever pressing for food reward. In an efficacy model, varenicline pretreatment dose-dependently reduced nicotine self-administration under a fixed-ratio schedule. Under a progressive ratio schedule rats worked harder for nicotine than for varenicline.

Human Studies

The rewarding potential of varenicline (1 mg and 3 mg doses) was compared with that of amphetamines in subjects experienced with psychomotor stimulants. The pattern for both smokers and non-smokers was consistent with a profile of a drug that, while having some pharmacological activity, did not produce amphetamine-like subjective effects.

Patient Counselling Information

Consumer Information is included in the package of CHAMPIX dispensed to the patient.

Prior to prescribing CHAMPIX, physicians should:

- Discuss with the patient the expected benefits and risks of CHAMPIX, as well as those of all smoking-cessation options.
- Inform the patients that quitting smoking, with or without treatment, may be associated with nicotine withdrawal symptoms (including depression, irritation or agitation) or exacerbation of pre-existing psychiatric disorder.

- Encourage the patient to reveal any history of psychiatric disorder prior to initiating treatment. Patients with such history who are trying to stop smoking should be monitored by their physician for new or worsened psychiatric events.
- Advise patients:
 - not to engage in potentially hazardous tasks, such as driving a car or operating dangerous machines, until they know how CHAMPIX may affect them. In some cases, patients have reported somnolence, dizziness, loss of consciousness, seizures or difficulty concentrating while driving.
 - that some people have reported seizures while taking CHAMPIX and encourage them to report any history of seizures or other factors that can lower seizure threshold. Instruct patients to discontinue CHAMPIX and immediately contact a healthcare provider if they experience a seizure while on treatment.
 - that there have been post-marketing reports of serious neuropsychiatric symptoms in patients being treated with CHAMPIX, including anxiety, psychosis, mood swings, aggression, depressed mood, agitation, hallucinations, hostility, changes in behavior or thinking, suicidal ideation, suicidal behavior and suicide, as well as worsening of pre-existing psychiatric disorder.
 - that i) new or worse cardiovascular events (heart and stroke) have been reported, primarily in those who already have cardiovascular problems and ii) based on available data, it is not possible to determine whether CHAMPIX increases the risk of cardiovascular events.

For those patients receiving CHAMPIX:

- Patients should be instructed to read the patient information leaflet supplied with every CHAMPIX prescription before starting their CHAMPIX pills. This leaflet is approved by Health Canada and is Part III of the CHAMPIX Product Monograph.
- Patients should also be provided with educational materials and necessary counselling to support an attempt at quitting smoking, including a review of the overall smoking cessation plan with the physician.
- Patients should call 1-800-CHAMPIX for a list of provincial Smoking Cessation resources (toll-free quit line) which can be used to support a quit attempt.
- Patients should be informed that there are three choices in setting a quit date when using CHAMPIX, and discuss with their physician which one is best for them.
- Patients should be instructed on how to titrate CHAMPIX:
 - Begin at a dose of 0.5 mg per day. Prescribers should explain that one 0.5 mg tablet should be taken daily for the first three days, and then for the next four days, two 0.5 mg tablets should be taken daily: one in the morning and one in the evening. **Following this one week of titration, there are two dosing options:** the dose can remain at 0.5 mg twice daily or can go up to 1.0 mg twice daily, depending on the physician judgment and patient preference. Based on the limited data available, the two doses do not appear different in terms of either quit rates, or rates of serious psychiatric side effects (see **DOSAGE AND ADMINISTRATION, Dosing Considerations**).
 - If needed, the dose can be changed depending on how well the patient tolerates

CHAMPIX and how effective the doctor and patient consider it is in helping the patient quit smoking.

- Patients should be informed that the maximum dose of CHAMPIX is 1.0 mg twice a day.
- Patients should be encouraged to continue in their quit attempt if they have early lapses after their quit date.
- Patients should be encouraged to inform friends and family members of their quit attempt which includes treatment with CHAMPIX and ask for their support and help in monitoring for any changes in behavior or thinking that are not typical for the patient.
- Patients should be advised that drinking alcohol may increase the risk of experiencing psychiatric adverse events during treatment with CHAMPIX.
- Patients with pre-existing psychiatric disorder should be instructed that if they develop worsened or new symptoms, to report these to their healthcare provider; dose adjustments of psychiatric medications or CHAMPIX may be considered.
- Patients should be informed that if they experience thoughts, moods or behaviours that are strongly atypical and concerning while on smoking-cessation medication, including CHAMPIX, the medication should be discontinued immediately, urgent medical help sought as needed, and the symptoms reported to their healthcare provider.
- Patients should be informed that:
 - they may experience vivid, unusual or strange dreams during treatment with CHAMPIX.
 - nausea is the most common adverse event associated with CHAMPIX and is usually transient. CHAMPIX should be taken after eating and with a full glass of water. Patients should be advised that if they are persistently troubled by this symptom, a dose reduction may be considered.
 - if they experience sleepwalking, they should discontinue CHAMPIX and notify their healthcare provider.
 - there have been reports of **angioedema**, with swelling of the face, mouth (tongue, lips and gums) and neck (pharynx and larynx) that can lead to life-threatening respiratory compromise. Patients should be instructed to discontinue CHAMPIX and seek immediate emergency medical attention if they experience these symptoms.
 - **serious skin reactions**, such as Stevens-Johnson syndrome and erythema multiforme, were reported by some patients taking CHAMPIX. Patients should be advised to stop taking CHAMPIX at the first sign of rash with mucosal lesions or skin reaction and seek immediate emergency medical attention.
- Patients should be instructed to notify their healthcare providers of symptoms of new or worsening cardiovascular events and to seek immediate medical attention if they experience signs and symptoms of myocardial infarction or stroke.

Special Populations

Use of CHAMPIX in Patients with Concomitant Conditions:

Psychiatric Patients

Smoking-cessation with or without pharmacotherapy, has been associated with the exacerbation of underlying psychiatric illness. Patients with a history of psychiatric symptoms who are attempting to quit smoking should be monitored by a healthcare professional for new or worsened psychiatric events (see **DOSAGE AND ADMINISTRATION, Special Populations, Psychiatric Patients**; as well as **WARNINGS AND PRECAUTIONS, Psychiatric Symptoms in Patients with and without Pre-existing Psychiatric Disorder or Symptoms**).

In a large randomized, double-blind, active and placebo-controlled smoking cessation study, use of CHAMPIX was not associated with an increased risk of serious neuropsychiatric adverse events in the composite endpoint compared with placebo, in patients with or without a history of psychiatric disorder (See **ACTION AND CLINICAL PHARMACOLOGY, Special Populations and Conditions, Neuropsychiatric Safety Study in Subjects with and without a History of Psychiatric Disorder**). Major depressive disorder, bipolar disorder I and II, anxiety, and schizophrenia were the primary baseline psychiatric conditions reported in the study; only patients judged to be clinically stable were included. Current substance abuse was among the conditions that were excluded.

Patients with Epilepsy

The use of CHAMPIX has not been studied in patients with epilepsy. There have been post-marketing reports of seizures in patients using varenicline. It is not known for how many of these there is a prior history or risk of a seizure disorder (see **WARNINGS AND PRECAUTIONS, Seizures**).

Patients with Diabetes

Smoking cessation, with or without treatment, may be associated with altered glycemic control. There have been post-marketing reports of diabetic patients experiencing loss of glycemic control while taking CHAMPIX. Therefore, increased glycemic monitoring is recommended in diabetic patients, with resultant adjustment of diabetic medications as necessary.

Patients with Irritable Bowel or Other Gastrointestinal (GI) Problems

The use of CHAMPIX has not been studied in patients with irritable bowel syndrome or other GI problems. Post marketing reports of irritable bowel syndrome, abdominal pain, faecal incontinence and other GI issues have been reported in patients taking CHAMPIX.

Patients Exposed to Chemotherapy

The use of CHAMPIX has not been studied in patients exposed to emetogenic chemotherapy.

Pregnant Women

Studies in animals have shown reproductive toxicity (see **TOXICOLOGY**). The potential risk for humans is not fully known (See **ACTION AND CLINICAL PHARMACOLOGY, Special Populations: Pregnant Women**). CHAMPIX should not be used during pregnancy.

Nonteratogenic Effects

Varenicline succinate has been shown to have an adverse effect on the fetus in animal reproduction studies. Administration of varenicline succinate to pregnant rabbits resulted in reduced fetal weights at an oral dose of 30 mg/kg/day (50 times the human AUC at 1.0 mg BID); this reduction was not evident following treatment with 10 mg/kg/day (23 times the maximum recommended daily human exposure based on AUC). In addition, in the offspring of pregnant rats treated with varenicline succinate there were decreases in fertility and increases in auditory startle response at an oral dose of 15 mg/kg/day (36 times the maximum recommended human daily exposure based on AUC at 1.0 mg BID).

Nursing Women

Animal studies have shown that varenicline can be transferred to nursing pups. It is not known whether varenicline is excreted in human milk. Because many drugs are excreted in human milk and because the potential for adverse reactions in nursing infants from CHAMPIX is unknown, a decision should be made whether to discontinue nursing or to discontinue the drug.

Pediatrics (<18 years of age)

Based on the data submitted and reviewed by Health Canada, the safety and efficacy of CHAMPIX in pediatric patients has not been established; therefore, Health Canada has not authorized an indication for pediatric use (see **WARNINGS AND PRECAUTIONS, Special Populations: Pediatrics**).

Geriatrics (>65 years of age)

A combined single and multiple-dose pharmacokinetic study demonstrated that the pharmacokinetics of 1.0 mg varenicline given once daily (QD) or BID to 16 healthy elderly male and female smokers (aged 65-75 years) for 7 consecutive days was similar to that of younger subjects. No overall differences in safety or effectiveness were observed between these subjects and younger subjects, and other reported clinical experience has not identified differences in responses between the elderly and younger patients, but greater sensitivity of some older individuals cannot be ruled out.

Varenicline is known to be substantially excreted by the kidney, and the risk of toxic reactions to this drug may be greater in patients with impaired renal function. Because elderly patients are more likely to have decreased renal function, care should be taken in dose selection, and it may be useful to monitor renal function (see **DOSAGE AND ADMINISTRATION, Special Populations: Geriatrics**).

Renal Impairment

A multiple dose pharmacokinetic study was conducted in patients with normal renal function, with mild, moderate, or severe renal impairment (estimated creatinine clearance: >80 mL/min, >50 and ≤80 mL/min, ≥ 30 and ≤50 mL/min, and <30 mL/min, respectively) or end-stage renal disease (ESRD). Varenicline pharmacokinetics was unchanged in subjects with mild renal impairment. Relative to subjects with normal renal function, varenicline exposure increased 1.5-fold in patients with moderate renal impairment and 2.1-fold in patients with severe renal impairment. In subjects with ESRD, varenicline was efficiently removed by hemodialysis. The recommended dose of CHAMPIX is reduced in patients with severe renal impairment.

CHAMPIX is not recommended in patients with ESRD (see **ACTION AND CLINICAL PHARMACOLOGY, Special Populations and Conditions: Renal Impairment, and DOSAGE AND ADMINISTRATION, Special Populations: Patients with Impaired Renal Function**).

ADVERSE REACTIONS

Adverse Drug Reaction Overview

Clinical Trial Adverse Drug Reactions

Smoking-cessation with or without treatment is associated with various symptoms. For example, dysphoric or depressed mood, insomnia, irritability, frustration or anger, anxiety, difficulty concentrating, restlessness, decreased heart rate, increased appetite or weight gain have been reported in patients attempting to stop smoking.

Overview

Pre-marketing clinical trials included approximately 2300 patients treated for at least 12 weeks, approximately 700 for 6 months, and approximately 100 for one year. In general, onset of adverse events was in the first few weeks of therapy and severity was generally mild to moderate. No differences were observed by age, race or gender with regard to the incidence of adverse reactions, although patient numbers in elderly, and in non-caucasian races were too limited to allow conclusions.

Commonly Observed Adverse Events

The most commonly observed adverse events associated with CHAMPIX (>5% and twice the rate seen in placebo-treated patients) were nausea, abnormal dreams, constipation, flatulence, and vomiting.

For patients exposed to the maximum recommended dose of 1.0 mg BID following initial dosage titration, the incidence of nausea was 30%, compared with 16% in 0.5 mg BID and approximately 10% in placebo-treated patients. Nausea was generally described as mild to moderate and often transient; however, for some subjects, it was persistent throughout the treatment period.

Adverse Events Leading to Discontinuation

In Phase 2 and 3 placebo-controlled studies, the treatment discontinuation rate due to adverse events in patients randomized to 12 weeks treatment with the recommended maximum dose of 1.0 mg BID was 12% for CHAMPIX compared to 10% for placebo. In this group, the adverse events most frequently resulting in treatment discontinuation in CHAMPIX treated patients were as follows: nausea (2.7% vs 0.6% for placebo), insomnia (1.3% vs 1.2% for placebo), fatigue/malaise/asthenia (1.0% vs 0.5% for placebo), and dizziness (0.7% vs 0.4% for placebo).

Table 1 shows the adverse events for CHAMPIX and placebo in the 12-week fixed dose studies with titration in the first week (Studies 1 (titrated arm only), 3, and 4). MedDRA High Level Group Terms (HLGT) reported in $\geq 5\%$ of patients in the CHAMPIX 1.0 mg BID dose group, and more commonly than in the placebo group, are listed, along with subordinate Preferred

Terms (PT) reported in $\geq 1\%$ of CHAMPIX patients (and at least 0.5% more frequently than placebo). Closely related Preferred Terms such as 'Insomnia', 'Initial insomnia', 'Middle insomnia', 'Early morning awakening' were grouped, but individual patients reporting two or more grouped events were only counted once.

Table 1. Common Treatment Emergent Adverse Events (%) in the 12-Week Fixed-Dose, Placebo-Controlled Studies ($\geq 1\%$ in the 1.0 mg BID CHAMPIX Group, and 1.0 mg BID CHAMPIX at least 0.5% more than Placebo)

SYSTEM ORGAN CLASS High Level Group Term Preferred Term	CHAMPIX 0.5 mg BID N=129	CHAMPIX 1.0 mg BID N=821	Placebo N=805
GASTROINTESTINAL			
GI Signs and Symptoms			
Nausea	16	30	10
Abdominal Pain *	5	7	5
Flatulence	9	6	3
Dyspepsia	5	5	3
Vomiting	1	5	2
GI Motility/Defecation Conditions			
Constipation	5	8	3
Gastroesophageal reflux disease	1	1	0
Salivary Gland Conditions			
Dry mouth	4	6	4
PSYCHIATRIC DISORDERS			
Sleep Disorder/Disturbances			
Insomnia **	19	18	13
Abnormal dreams	9	13	5
Sleep disorder	2	5	3
Nightmare	2	1	0
NERVOUS SYSTEM			
Headaches			
Headache	19	15	13
Neurological Disorders NEC			
Dysgeusia	8	5	4
Somnolence	3	3	2
Lethargy	2	1	0
GENERAL DISORDERS			
General Disorders NEC			
Fatigue/Malaise/Asthenia	4	7	6
RESPIR/THORACIC/MEDIAST			
Respiratory Disorders NEC			
Rhinorrhea	0	1	0
Dyspnea	2	1	1
Upper Respiratory Tract Disorder	7	5	4
SKIN/SUBCUTANEOUS TISSUE			
Epidermal and Dermal Conditions			
Rash	1	3	2
Pruritus	0	1	1
METABOLISM & NUTRITION			
Appetite/General Nutrition Disorders			
Increased appetite	4	3	2
Decreased appetite/Anorexia	1	2	1

* Includes PTs Abdominal (pain, pain upper, pain lower, discomfort, tenderness, distension) and Stomach discomfort

** Includes PTs Insomnia/Initial insomnia/Middle insomnia/Early morning awakening

NEC: Not Elsewhere Classified

Initial dose titration was beneficial in reducing the occurrence of nausea.

An additional 12 weeks of CHAMPIX 1.0 mg BID was well-tolerated in patients who had completed 12 weeks of treatment and had stopped smoking. Adverse events resulted in treatment discontinuation in 1.7% of patients who received CHAMPIX compared with 1.3% of placebo patients.

Safety Study: One-Year, Double-Blind Drug-Treatment

The overall pattern and the frequency of adverse events during a 52-week trial with CHAMPIX 1.0 mg BID (n=251 subjects randomized to CHAMPIX arm, and n=126 to placebo arm) were similar to those described in Table 1, except for the following events which were seen to be increased relative to placebo, as compared to the profile for 12 week drug exposure: nausea (40% vs 8% placebo); and the pooled terms of: abdominal pain (17% vs 3% placebo), and increased blood pressure (11% vs 6% placebo). Few of these events were recorded as severe.

Neuropsychiatric Adverse Events in Randomized, Double-Blind, Placebo-Controlled Clinical Studies of Varenicline

Meta-Analysis of Columbia-Suicide Severity Rating Scale (C-SSRS)

A meta-analysis of 5 randomized, double blind, placebo controlled trials, including 1907 patients (1130 CHAMPIX, 777 placebo), was conducted to assess suicidal ideation and behavior as reported on the C-SSRS. This meta-analysis included one trial (N=127) in patients with a history of schizophrenia or schizoaffective disorder and another trial (N=525) in patients with a history of depression. The results showed no increase in the incidence of suicidal ideation and/or behavior in patients treated with CHAMPIX compared to patients treated with placebo, with a Risk Ratio (RR) of 0.79 (95% Confidence Interval [CI]: 0.46, 1.36), as shown in **Table 2**. Forty-eight (48) of the 55 patients who reported suicidal ideation or behavior (24 CHAMPIX, 24 placebo) were from the two trials that enrolled patients with a history of schizophrenia, schizoaffective disorder, or depression (see **ACTION AND CLINICAL PHARMACOLOGY, Special Populations and Conditions**). Few patients reported these events in the other three trials (4 CHAMPIX, 3 placebo).

Table 2. Number of Patients and Risk Ratio for Suicidal Ideation and/or Behavior Reported on C-SSRS from a Meta-Analysis of 5 Clinical Trials Comparing CHAMPIX to Placebo

	CHAMPIX (N=1130)	Placebo (N=777)
Patients with suicidal ideation and/or behavior* [n (%)]**	28 (2.5)	27 (3.5)
Patient-years of exposure	325	217
Risk Ratio # (RR; 95% CI)	0.79 (0.46, 1.36)	

* Of these, one patient in each treatment arm reported suicidal behavior

** Patients with events up to 30 days after treatment; % are not weighted by study

RR of incidence rates per 100 patient years

Pooled Data including Ten Smoking Cessation Trials

Table 3 below provides the incidence of all causality, treatment-emergent neuropsychiatric adverse events with varenicline as compared to placebo ($\geq 0.2\%$ more than placebo) in adult smokers, adverse event summarized from all randomized, placebo-controlled, double-blind

varenicline studies (10 studies) completed by 31 December 2008, regardless of Study Dose or Duration. Four of these are described in the CLINICAL TRIALS section. There were no suicidal and self-injurious behaviors reported (suicide ideation and suicide attempt) in the varenicline group versus 2 events (0.1%) in the placebo group.

Table 3: All-Causality Treatment-Emergent Neuropsychiatric Adverse Events (%) in Ten Completed Phase 2/4 Placebo-Controlled Studies ($\geq 0.2\%$ more than placebo)

Neuropsychiatric Adverse Events	Varenicline (N =3091)	Placebo (N =2005)
	% (n)	% (n)
Psychiatric Disorders*		
Depressed mood disorders and disturbances	2.8 (88)	1.9 (38)
Depression	1.6 (51)	1.2 (24)
Depressed mood	1.0 (32)	0.6 (12)
Disturbances in thinking and perception	0.4 (13)	0.1 (2)
Thinking abnormal	0.2 (7)	-- (1)
Mood disorders and disturbances NEC	2.4 (73)	1.5 (30)
Affect lability	0.6 (20)	0.3 (6)
Mood swings	0.3 (10)	0.1 (2)
Apathy	0.2 (5)	-- (1)
Psychiatric disorders NEC	0.5 (16)	0.3 (6)
Sleep disorders and disturbances	25.1 (776)	14.5 (291)
Insomnia	13.9 (431)	9.5 (191)
Abnormal dreams	9.9 (305)	3.6 (73)
Sleep disorder	3.1 (97)	1.7 (35)
Middle insomnia	1.1 (35)	0.3 (7)
Initial insomnia	1.0 (30)	0.6 (12)
Nightmare	0.5 (17)	0.3 (7)
Early morning awakening	0.4 (13)	0.1 (3)
Nervous System Disorders**		
Mental impairment disorders	4.0 (124)	3.6 (73)
Disturbance in attention	3.4(104)	3.1 (63)
Amnesia	0.3 (9)	0.1 (2)
Neurological disorders NEC	16.4 (507)	13.0 (260)
Dysgeusia	6.2 (193)	3.2 (64)
Somnolence	3.4 (105)	2.4 (49)
Lethargy	0.8 (25)	0.4 (8)

MedDRA version 11; included data up to 30 days after last dose of drug

NEC: Not Elsewhere Classified

Number (%) of Subjects with Adverse Events by:

* **Psychiatric Disorders System Organ Class: All High Level Group Terms (HLGT)**

and Preferred Terms (PTs) reported in each HLGT that are $\geq 0.2\%$ greater than placebo.

** **Nervous System Disorder System Organ Class Selected HLGTs and PTs** reported in each HLGT that are $\geq 0.2\%$ greater than placebo.

Data from One Phase 2 Trial with Two Varenicline Doses

Data are shown from the Phase 2 trial (12 weeks duration) that included both efficacious doses, 0.5 mg BID and 1.0 mg BID (see **CLINICAL TRIALS, Study 1**).

Table 4: All-Causality Treatment-Emergent Neuropsychiatric Adverse Events (%) in one Phase 2 Dose Response Study that included both, 0.5 mg BID and 1.0 mg BID doses, ($\geq 1\%$ greater than placebo for any varenicline dose regimen)

Neuropsychiatric Adverse Events *	0.5 mg BID (N= 253)	1.0 mg BID (N=253)	Placebo (N= 121)
	% (n)	% (n)	% (n)
Total Psychiatric Disorders			
<u>Depressed mood disorders and disturbances</u>	4.3 (11)	3.2 (8)	3.3 (4)
Depressed mood	1.2 (3)	0.8 (2)	-- (0)
<u>Disturbances in thinking and perception</u>	1.2 (3)	0.8 (2)	-- (0)
Thinking abnormal	1.2 (3)	-- (0)	-- (0)
<u>Mood disorders and disturbances NEC</u>	2.8 (7)	3.6 (9)	3.3 (4)
Affect lability	0.8 (2)	2.0 (5)	0.8 (1)
<u>Sexual dysfunction, disturbances and gender identity disorders</u>	0.4 (1)	1.6 (4)	-- (0)
Libido decreased	-- (0)	1.6 (4)	-- (0)
<u>Sleep disorders and disturbances</u>	34.4 (87)	36.4 (92)	15.7 (19)
Insomnia	20.6 (52)	22.9 (58)	9.9 (12)
Abnormal dreams	12.6 (32)	18.2 (46)	4.1 (5)
Sleep disorder	2.4 (6)	4.0 (10)	0.8 (1)
Initial insomnia	3.2 (8)	1.2 (3)	1.7 (2)
Early morning awakening	1.2 (3)	0.8 (2)	-- (0)
<u>Nervous System Disorders**</u>			
<u>Mental impairment disorders</u>	6.3 (16)	9.9 (25)	4.1 (5)
Disturbance in attention	5.9 (15)	7.9 (20)	4.1 (5)
Amnesia	-- (0)	1.2 (3)	-- (0)
<u>Neurological disorders NEC</u>	22.9 (58)	24.9 (63)	14.0 (17)
Dysgeusia	11.9 (30)	12.6 (32)	4.1 (5)
Somnolence	3.6 (9)	7.1 (18)	1.7 (2)
Lethargy	1.2 (3)	2.8 (7)	-- (0)
Hypoaesthesia	0.4 (1)	1.2 (3)	-- (0)

MedDRA version 11; included data up to 30 days after last dose of drug

NEC: Not Elsewhere Classified

Number (%) of Subjects with Adverse Events by:

* **Psychiatric Disorder System Organ Class: High Level Group Terms (HLGT) and Preferred Terms (PT)** reported in each HLGT $\geq 1\%$ greater than placebo.

** **Nervous System Disorders System Organ Class:** Selected HLGTs and PTs reported in each HLGT $\geq 1\%$ greater than placebo.

Additional Clinical Trial Adverse Drug Reactions

The adverse drug reactions listed below are based on evaluation of data from pre-marketing phase 2-3 studies and updated based on a pooled database of a total of 18 placebo-controlled, pre- and post-marketing smoking cessation studies, with approximately 5,000 patients treated with CHAMPIX. All reported events are included except those already listed in Table 1, those too general to be informative, and those not reasonably possibly associated with the use of the drug. In some cases, separate event terms have been consolidated to facilitate meaningful presentation. It is important to emphasize that although the events reported occurred during treatment with CHAMPIX, they were not necessarily caused by it.

The ADRs listed below are presented by the Medical Dictionary for Regulatory Activities (MedDRA, Version 16) System Organ Class (SOC). The variability associated with adverse event reporting and the terminology used to describe adverse events limit the value of the quantitative frequency estimates provided. Events are further classified within system organ class categories and enumerated in order of decreasing frequency using the following definitions: very frequent (occurring in at least 1/10 patients), frequent (occurring in at least 1/100 patients), infrequent (occurring in <1/100 to 1/1000 patients) and rare (occurring in fewer than 1/1000 patients).

Blood and Lymphatic System Disorders: *Infrequent:* Anemia, Lymphadenopathy. *Rare:* Leukocytosis, Platelet count decreased, Thrombocytopenia, Splenomegaly.

Cardiac Disorders: *Infrequent:* Angina pectoris, Electrocardiogram abnormal, Heart rate increased, Myocardial infarction, Palpitations, Tachycardia. *Rare:* Arrhythmia, Atrial fibrillation, Bradycardia, Cardiac flutter, Coronary artery disease, Cor pulmonale, Acute coronary syndrome, Electrocardiogram ST segment depression, Electrocardiogram T wave amplitude decreased, Ventricular extrasystoles.

Ear and Labyrinth Disorders: *Infrequent:* Tinnitus, Vertigo. *Rare:* Deafness, Meniere's disease.

Endocrine Disorders: *Infrequent:* Thyroid gland disorders.

Eye Disorders: *Infrequent:* Conjunctivitis, Eye irritation, Vision blurred, Visual-impairment, Eye pain. *Rare:* Acquired night blindness, Blindness transient, Cataract subcapsular, Dry eye, Mydriasis, Myopia, Lacrimation increased, Ocular vascular disorder, Photophobia, Scleral discolouration, Scotoma, Vitreous floaters.

Gastrointestinal Disorders: *Frequent:* Diarrhea, Toothache. *Infrequent:* Change of bowel habit, Aphthous stomatitis, Gingival pain, Dysphagia, Eructation, Gastritis, Gastrointestinal hemorrhage, Hematochezia, Mouth ulceration. *Rare:* Abnormal feces, Enterocolitis, Esophagitis, Gastric ulcer, Hematemesis, Intestinal obstruction, Pancreatitis acute, Tongue coated.

General Disorders and Administration Site Conditions: *Frequent:* Chest pain, Irritability. *Infrequent:* Chest discomfort, Chills, Edema, Influenza like illness, Pyrexia, Thirst. *Rare:* Cyst, Feeling cold.

Hepatobiliary Disorders: *Rare:* Gall bladder disorder, Worsening of existing autoimmune hepatitis.

Immune System Disorders: *Infrequent:* Hypersensitivity. *Rare:* Drug hypersensitivity.

Infections and Infestations: *Very frequent:* Nasopharyngitis. *Frequent:* Bronchitis, Sinusitis. *Infrequent:* Fungal infection, Gingivitis, Viral infection, Tooth abscess, Urinary Tract Infection.

Investigations: *Frequent:* Liver function test abnormal, alanine aminotransferase increased, *Rare:* Muscle enzyme increased, Semen abnormal, C-reactive protein increased, Blood calcium decreased, Urine analysis abnormal.

Metabolism and Nutrition Disorders: *Frequent:* Weight increased. *Infrequent:* Diabetes mellitus, Hypoglycemia. *Rare:* Hyperkalemia, Hyperlipidemia, Hypokalemia, Polydipsia.

Musculoskeletal and Connective Tissue Disorders: *Frequent:* Arthralgia, Back pain, Myalgia. *Infrequent:* Arthritis, Musculoskeletal chest pain, Muscle cramp, Musculoskeletal pain, Muscle spasms. *Rare:* Costochondritis, Joint stiffness, Myositis, Osteoporosis.

Nervous System Disorders: *Frequent:* Disturbance in attention, Dizziness, Somnolence. *Infrequent:* Amnesia, Convulsion, Hypoesthesia, Migraine, Parosmia, Syncope, Tremor. *Rare:* Balance disorder, Cerebrovascular accident, Circadian rhythm sleep disorder, Coordination abnormal, Dysarthria, Hypertonia, Hypogeusia, Mental impairment, Multiple sclerosis, VIIth nerve paralysis, Nystagmus, Psychomotor hyperactivity, Psychomotor skills impaired, Restless legs syndrome, Sensory disturbance, Transient ischemic attack, Visual field defect.

Psychiatric Disorders: *Frequent:* Agitation, Anxiety, Depression. *Infrequent:* Aggression, Dissociation, Libido decreased, Libido increased, Mood swings, Panic reaction, Restlessness, Suicidal ideation, Thinking abnormal. *Rare:* Bradyphrenia, Disorientation, Dysphoria, Emotional disorder, Euphoric mood, Hallucination, Psychotic disorder, Suicide attempt.

Renal and Urinary Disorders: *Infrequent:* Nocturia, Pollakiuria, Urine abnormality. *Rare:* Glycosuria, Nephrolithiasis, Polyuria, Renal failure acute, Urethral syndrome, Urinary retention.

Reproductive System and Breast Disorders: *Frequent:* Menstrual disorder. *Infrequent:* Erectile dysfunction, Menorrhagia. *Rare:* Sexual dysfunction, Vaginal discharge.

Respiratory, Thoracic and Mediastinal Disorders: *Frequent:* Cough, Respiratory disorders. *Infrequent:* Asthma, Dysphonia, Epistaxis, Rhinitis allergic, Throat irritation, Respiratory tract congestion, Sinus congestion, Rhinorrhea, Upper-airway cough syndrome, Upper respiratory tract inflammation. *Rare:* Laryngeal pain, Pleurisy, Pulmonary embolism, Snoring.

Skin and Subcutaneous Tissue Disorders: *Frequent:* Rash. *Infrequent:* Acne, Dry skin, Eczema, Erythema, Hyperhidrosis, Night sweats, Urticaria. *Rare:* Dermatitis, Photosensitivity reaction, Psoriasis.

Vascular Disorders: *Frequent:* Hypertension. *Infrequent:* Blood pressure increased, Hot flush, Hypotension. *Rare:* Peripheral ischemia, Thrombosis.

Clinical Trials in Special Populations

Adverse Events in Adolescents: (see ACTION AND CLINICAL PHARMACOLOGY, Special Populations and Conditions, Pediatrics).

Cardiovascular Adverse Events in Pooled Clinical Studies of Varenicline

In pooled data of 14 completed randomized double-blind placebo controlled smoking cessation trials (not including the study in patients with stable cardiovascular disease), the rate of reported treatment-emergent myocardial infarction (MI) or cerebrovascular accident (CVA) related adverse events was: 8 of 3317 (0.24%) patients on CHAMPIX (>1 mg), compared to 4 of 2542 (0.16%) patients on placebo.

Study in patients with Cardiovascular Disease

CHAMPIX was evaluated in a randomized, double-blind, placebo-controlled study of 703 subjects aged 35 to 75 years with stable, documented cardiovascular disease (other than or in addition to hypertension) that had been diagnosed for more than 2 months. Patients were treated with CHAMPIX 1 mg BID or placebo for 12 weeks, and then followed for another 40 weeks post-treatment (See WARNINGS AND PRECAUTIONS, Cardiovascular Events).

There are two partially overlapping data sets of cardiovascular events from the study:

- i) Treatment-emergent CV AEs captured via standard clinical trial AE reporting, while on drug treatment, (including, 30 days post-dose); and
- ii) Pre-specified serious CV events that were adjudicated by an independent blinded committee captured throughout the 52 week duration (ie both “on-treatment” [including 30 days post-dose], and “post-treatment”).

The study was powered for assessing efficacy (ie quit rates) but not for assessing differences in the occurrence of serious CV events between CHAMPIX and placebo.

More cardiovascular events were reported in both arms compared to other studies, as expected due to underlying conditions.

Treatment-emergent cardiovascular events which occurred within 30 days after the last dose, and in at least 3 subjects in either arm, are shown in **Table 5**.

Table 5: Treatment-Emergent Cardiovascular Events that occurred within 30 days after the last dose and in at least 3 subjects in any treatment arm

Cardiovascular Adverse Events	Varenicline (N = 353)	Placebo (N = 350)
	n (%)	n (%)
Angina pectoris	13 (3.7)	7 (2.0)
Chest pain	9 (2.5)	8 (2.3)
Peripheral edema	7 (2.0)	4 (1.1)
Arteriosclerosis	3 (0.8)	0 (0)
Hypertension	5 (1.4)	9 (2.6)
Palpitations	2 (0.6)	4 (1.1)

The adjudicated serious cardiovascular events are shown below in **Table 6**.

Patients are counted only once within each row per study phase.

As shown in **Table 6**, the individual serious cardiovascular (CV) events that were reported more frequently in CHAMPIX compared to placebo (difference > 2 subjects) were: non-fatal myocardial infarctions (4 vs. 1, on-treatment phase) and need for coronary revascularization (7 vs. 2, post-treatment phase). Some of the patients requiring coronary revascularization underwent the procedure as part of management of nonfatal MI and hospitalization for angina.

Table 6: Summary of Adjudicated Cardiovascular Events (including CV death) over the 52 Weeks of the Study

	Varenicline N=353			Placebo N = 350		
	Study Treatment Phase	Study Post- Treatment Follow-Up Phase	Total Study Duration (52 Weeks)	Study Treatment Phase	Study Post- Treatment Follow-Up Phase	Total Study Duration (52 Weeks)
Number of subjects with CV event, n (%)						
# of subjects with at least 1 CV event (including CV death)	10 (2.8)	16 (4.5)	25 (7.1)	9 (2.6)	11 (3.1)	20 (5.7)
Types of CV Events						
Nonfatal myocardial infarction	4 (1.1)	3 (0.8) ^a	7 (2.0)	1 (0.3)	2 (0.6) ^b	3 (0.9)
Need for coronary revascularization	1 (0.3)	7 (2.0) ^a	8 (2.3)	1 (0.3)	2 (0.6)	3 (0.9)
Hospitalization for angina pectoris	2 (0.6)	6 (1.7)	8 (2.3)	4 (1.1)	4 (1.1) ^a	8 (2.3)
Hospitalization for congestive heart failure	0 (0)	0 (0)	0 (0)	2 (0.6)	0 (0)	2 (0.6)
Nonfatal stroke	2 (0.6)	0 (0)	2 (0.6)	0 (0)	1 (0.3)	1 (0.3)
Transient ischemic attack	0 (0)	1 (0.3)	1 (0.3)	1 (0.3)	0 (0)	1 (0.3)
New diagnosis of peripheral vascular disease (PVD) or admission for a procedure for the treatment of PVD	1 (0.3)	5 (1.4)	5 (1.4)	1 (0.3)	2 (0.6)	3 (0.9)
Cardiovascular death	0 (0)	1 (0.3) ^a	1 (0.3)	1 (0.3)	1 (0.3)	2 (0.6)

^a one of the events occurred while the subject was taking during the post treatment phase "off-protocol" CHAMPIX or ^b CHAMPIX and other smoking cessation medication.

CHAMPIX was not studied in patients with unstable cardiovascular disease or those with cardiovascular events occurring within two months before screening. (See also: **WARNINGS AND PRECAUTIONS, Cardiovascular Events, and ACTION AND CLINICAL PHARMACOLOGY, Special Populations and Conditions**)

Cardiovascular Safety Assessment Study in Patients with and without a History of Psychiatric Disorder

The cardiovascular (CV) safety of CHAMPIX was evaluated in the Cardiovascular Safety Assessment Study in subjects with and without a history of psychiatric disorder. Subjects aged 18-75 years, smoking 10 or more cigarettes per day (N=8058) were randomized 1:1:1:1 to CHAMPIX 1 mg BID, bupropion SR 150 mg BID, nicotine replacement therapy patch (NRT) 21 mg/day with taper or placebo for a treatment period of 12 weeks; they were then followed another 12 weeks post-treatment through a period of up to a total of 52 weeks. Of all treated subjects, 1749 (21.7%) had a medium CV risk and 644 (8.0%) had a high CV risk, as defined by Framingham score.

Major adverse cardiovascular event (MACE), were defined as cardiovascular death, non-fatal myocardial infarction or non-fatal stroke during treatment.

Deaths and cardiovascular events were adjudicated by a blinded, independent committee. The study was not powered for assessing differences between CHAMPIX and placebo in the time to MACE.

The following table shows the incidence of MACE for all treatment groups during treatment, and cumulative for treatment plus 30 days and through end of study.

	Varenicline N=2016	Bupropion N=2006	NRT N=2022	Placebo N=2014
During treatment				
MACE, n (%)	1 (0.05)	2 (0.10)	1 (0.05)	4 (0.20)
During treatment plus 30 days				
MACE, n (%)	1 (0.05)	2 (0.10)	2 (0.10)	4 (0.20)
Through end of study				
MACE, n (%)	3 (0.15)	9 (0.45)	6 (0.30)	8 (0.40)

Because of the relatively low number of events overall and the lack of power for assessing differences between CHAMPIX and placebo, an association between the use of CHAMPIX and an increased risk of CV adverse events cannot be entirely ruled out.

Post-Marketing Experience

The following adverse events have been reported during post-approval use of CHAMPIX. Because these events are reported voluntarily from a population of uncertain size, it is not always possible to reliably estimate their frequency or establish a causal relationship to drug exposure.

Psychiatric Symptoms

There have been reports of depressed mood, agitation, aggression, hostility, anxiety, changes in behavior or thinking, mania, psychosis, hallucinations, paranoia, delusions, homicidal ideation, mood swings, suicidal ideation and completed suicide in patients attempting to quit smoking while taking CHAMPIX (see **WARNINGS AND PRECAUTIONS, Psychiatric Symptoms in Patients with and without Pre-existing Psychiatric Disorder or Symptoms**). Of the cases with information provided, the majority reported possible contributing factors, including

primarily prior psychiatric history and/or concurrent psychiatric medications. Smoking status at the time of event onset was not reported in most cases. Patients should be advised that drinking alcohol may increase the risk of experiencing psychiatric adverse events. Smoking cessation with or without treatment is associated with nicotine withdrawal symptoms and the exacerbation of underlying psychiatric illness. The role of CHAMPIX in these reports is not known (see also **WARNINGS AND PRECAUTIONS, Psychiatric Symptoms in Patients with and without Pre-existing Psychiatric Disorder or Symptoms**).

Hypersensitivity and Serious Skin Reactions

There have also been reports of hypersensitivity reactions, including angioedema and of rare but severe cutaneous reactions including Stevens-Johnson syndrome and erythema multiforme in patients taking CHAMPIX (see **WARNINGS AND PRECAUTIONS, Angioedema and Hypersensitivity Reactions and Serious Skin Reactions**).

Myocardial Infarction and Cerebrovascular Accident

There have been reports of myocardial infarction (MI) and cerebrovascular accident (CVA) including ischemic and hemorrhagic events in patients taking Champix. In the majority of the reported cases, patients had preexisting cardiovascular disease and/or other risk factors. Although smoking is a risk factor for MI and CVA, a contributory role of varenicline cannot be ruled out, based on temporal relationship between medication use and events.

Hyperglycemia and Diabetes Mellitus

Smoking cessation, with or without treatment, may be associated with altered glycemic control. There have been reports of hyperglycemia in patients taking CHAMPIX. While the majority of these cases involved diabetic patients experiencing loss of glycemic control (see **Special Populations, Patients with Diabetes**), there have also been reports of new onset diabetes in patients with no pre-existing diabetes or pre-diabetes.

DRUG INTERACTIONS

Overview

Based on varenicline pharmacokinetic characteristics, and clinical experience to date, it appears unlikely that CHAMPIX would produce or be subject to clinically meaningful drug interactions.

Drug interaction studies were performed with varenicline and: cimetidine, metformin, digoxin, warfarin, transdermal nicotine and bupropion.

No clinically meaningful pharmacokinetic drug interactions have been identified, other than potential for interaction with cimetidine in patients with severe renal impairment (see ***Cimetidine***, below).

Drugs cleared by, or which affect, cytochrome P450 enzymes

In vitro studies demonstrated that varenicline does not inhibit cytochrome P450 enzymes (IC₅₀ >6400 ng/mL). The P450 enzymes tested for inhibition were: 1A2, 2A6, 2B6, 2C8, 2C9, 2C19, 2D6, 2E1, and 3A4/5. Also, in human hepatocytes *in vitro*, varenicline did not induce the

activity of cytochrome P450 enzymes 1A2 and 3A4. Therefore, varenicline is unlikely to alter the pharmacokinetics of compounds that are primarily metabolized by cytochrome P450 enzymes.

Furthermore, since metabolism of varenicline represents less than 10% of its clearance, drugs known to affect the cytochrome P450 system are unlikely to alter the pharmacokinetics of CHAMPIX (see **ACTION AND CLINICAL PHARMACOLOGY: Pharmacokinetics**) and therefore a dose adjustment of CHAMPIX should not be required for these types of drugs.

Drugs cleared by, or which affect, renal secretion

In vitro studies demonstrated that varenicline does not inhibit human renal transport proteins at therapeutic concentrations. Therefore, drugs that are cleared by renal secretion (eg, metformin - see below) are unlikely to be affected by varenicline.

In vitro studies demonstrated the active renal secretion of varenicline is mediated by the human organic cation transporter, hOCT2. In patients with normal renal function coadministration with inhibitors of hOCT2 does not require a dose adjustment of CHAMPIX as the increase in systemic exposure to CHAMPIX is not expected to be clinically meaningful except in cases of severe renal impairment (see *Cimetidine*, and *Other Inhibitors of hOCT2* below).

Drug-Drug Interactions

Alcohol

Patients should be advised that alcohol intake may increase the risk of experiencing psychiatric adverse events during treatment with CHAMPIX (See **WARNINGS and PRECAUTIONS, Psychiatric Symptoms in Patients with and without Pre-existing Psychiatric Disorder or Symptoms**; see also **Patient Counselling Information**).

Drug-drug interaction studies were limited to approximately two-week studies in healthy young adult volunteers who smoked.

Single dosing for one of the two drugs:

Cimetidine: Co-administration of varenicline (2 mg single dose) with an hOCT2 inhibitor, cimetidine (300 mg four times daily (QID) at steady-state) to 12 smokers increased the systemic exposure of varenicline by 29% (90% CI: 21.5%, 36.9%) due to a reduction in varenicline renal clearance. No dosage adjustment is recommended based on concomitant cimetidine administration in subjects with normal renal function or in patients with mild to moderate renal impairment. In patients with severe renal impairment, the concomitant use of cimetidine and varenicline should be avoided (see **DOSAGE AND ADMINISTRATION, Recommended Dose and Dosage Adjustment: Special Populations, Patients with Impaired Renal Function**).

Other inhibitors of hOCT2: Other inhibitors of hOCT2 have not been directly studied. Cimetidine causes greater *in vivo* drug interactions with renally cleared compounds than other inhibitors of hOCT2. Consequently, co-administration of other inhibitors of hOCT2 with varenicline would not require dosage adjustment in patients with normal renal function or

moderate renal impairment. In patients with severe renal impairment, the concomitant use of varenicline and other inhibitors of hOCT2, such as trimethoprim, ranitidine or levofloxacin should be avoided (see **DOSAGE AND ADMINISTRATION, Recommended Dose and Dosage Adjustment: Special Populations, Patients with Impaired Renal Function**).

Co-administration with Other Drugs Eliminated via hOCT2: Based on the lack of interaction between varenicline and metformin, interactions between varenicline and other cationic drugs eliminated via hOCT2 are unlikely.

Warfarin: Varenicline (1 mg BID steady-state) did not alter the pharmacokinetics of a single 25 mg dose of (R, S)-warfarin in 24 smokers. Prothrombin time (INR) was not affected by CHAMPIX. Smoking-cessation itself may result in changes to warfarin pharmacokinetics (see **WARNINGS AND PRECAUTIONS**).

Multiple dosing for both drugs:

Metformin: When co-administered to 30 smokers, varenicline (1 mg BID) did not alter the steady-state pharmacokinetics of metformin (500 mg BID), which is a substrate of hOCT2. Metformin had no effect on varenicline steady-state pharmacokinetics.

Digoxin: Varenicline (1 mg BID) did not alter the steady-state pharmacokinetics of digoxin administered as a 0.25 mg daily dose in 18 smokers. Steady-state pharmacokinetics of varenicline remained unchanged by digoxin co-administration.

Use with other therapies for smoking-cessation:

Safety and efficacy of varenicline in combination with other smoking-cessation therapies, such as bupropion or nicotine replacement therapy, have not been studied.

Bupropion: Varenicline (1 mg BID) did not alter the steady-state pharmacokinetics of bupropion (150 mg BID) in 46 smokers. Steady-state pharmacokinetics of varenicline remained unchanged by bupropion co-administration.

Nicotine replacement therapy (NRT): When varenicline (1 mg BID) and NRT (transdermal, 21 mg/day) were co-administered to 24 smokers for 12 days, there was a statistically significant decrease in average systolic blood pressure (mean 2.6 mmHg) measured on the final day of the study. In this study, the incidence of nausea, headache, vomiting, dizziness, dyspepsia and fatigue were greater for the combination of varenicline and NRT than for NRT alone. Due to the partial agonist nicotinic activity of varenicline, it is not anticipated that co-administration with NRT would confer additional benefits compared with CHAMPIX alone, and may result in increased side effects (see **WARNINGS AND PRECAUTIONS**).

Drug-Food Interactions

Oral bioavailability of CHAMPIX is unaffected by food.

Drug-Herb Interactions

CHAMPIX has no known drug-herb interactions.

Drug-Laboratory Interactions

CHAMPIX has no known drug-laboratory test interactions.

DOSAGE AND ADMINISTRATION

Dosing Considerations

Smoking-cessation therapies are more likely to succeed for patients who are motivated to stop smoking and who are provided additional counselling and /or support services. In the clinical trials on which approval was based, CHAMPIX was used with supportive counselling. Physicians should review the patient's overall smoking-cessation plan that includes treatment with CHAMPIX.

The majority of clinical evidence in efficacy and safety was based on a 1.0 mg BID dose (see **CLINICAL TRIALS**). There is little clinical experience with doses above the maximum recommended dose of 1 mg BID.

There is limited data available for dose comparison. In the one randomized clinical trial that included both 1.0 mg BID and 0.5 mg BID arms and that was designed to compare each of the two doses to placebo, and not to each other, the quit rates for 1.0 mg BID (n=253), 0.5 mg BID (n=253) and placebo (n=121) were:

- for Weeks 9 to 12: 51%, 45%, and 12% respectively, and
- for Weeks 9 to 52: 23%, 19% and 4% respectively.

For further information on this study, see **CLINICAL TRIAL**, study 1.

Based on the limited data available, it cannot be concluded that there is a difference between the two doses in the rate of serious neuropsychiatric events (see **ADVERSE REACTIONS, Neuropsychiatric Adverse Events in Randomized Double Blind, Placebo Controlled Clinical Studies of Varenicline**).

CHAMPIX should be taken after eating and with a full glass of water.

Patients with Severe Renal Impairment

The maximum recommended dose for this population is 0.5 mg twice daily (see below: **Special Populations, *Patients with Impaired Renal Function***).

Recommended Dose and Dosage Adjustment

Adults

Setting a quit date:

There are three ways to set a quit date with CHAMPIX:

- **Fixed quit approach:** The patient sets a date to stop smoking. CHAMPIX dosing should start 1-2 Weeks before this date (see **CLINICAL TRIALS**).

or

- **Flexible quit approach:** The patient begins CHAMPIX and then quits smoking between days 8 and 35 of treatment (ie between Weeks 2 and 5) (see **ACTION AND CLINICAL PHARMACOLOGY, Special Populations, Flexibility in Setting a Quit Date**).

or

- **Gradual quit approach:** The patient starts taking CHAMPIX with a goal to quit smoking by end of 12 weeks of treatment. The patient should gradually reduce smoking during the first 12 weeks of treatment such as 50% reduction or more by 4 weeks of treatment, 75% or more by 8 weeks to reach 100% by 12 weeks (see **ACTION AND CLINICAL PHARMACOLOGY, Special Populations**).

Dosing Options

Following one week of titration, there is a choice of two doses for CHAMPIX: 0.5 mg BID or 1.0 mg BID.

As shown in the table below, the two titration schedules are identical from Day 1 to Day 7, separating at Day 8 when the patient either remains on 0.5 mg BID or moves up to 1.0 mg BID.

Day	Dosing regimen	
	0.5 mg BID	1.0 mg BID
Days 1 – 3:	0.5 mg once daily	0.5 mg once daily
Days 4 – 7:	0.5 mg twice daily	0.5 mg twice daily
Day 8 – onward	0.5 mg twice daily	1.0 mg twice daily

The choice of dosing regimen should be based on physician judgment and patient preference, following discussion with the patient (see also **Dosing Considerations**).

Once CHAMPIX treatment is initiated, the dose may be changed, temporarily or permanently, according to patient and physician judgments on tolerability and efficacy.

Patients who follow one of the first 2 approaches to setting a quit date (1-2 weeks after starting the treatment or between days 8 and 35 of treatment) should be treated with CHAMPIX for 12 weeks. For patients who have successfully stopped smoking at the end of 12 weeks, an additional course of 12 weeks treatment with CHAMPIX may be considered. No data are available on the efficacy of an additional 12 week course of treatment with CHAMPIX for patients who have not successfully stopped smoking at the end of 12 weeks.

Patients who follow the gradual quit approach (Week 12) should be treated with CHAMPIX for 24 weeks.

Dose tapering may be considered. Regardless of whether the treatment course is 12 or 24 weeks,

risk of smoking-cessation relapse is elevated in the period immediately following the end of drug treatment (see **CLINICAL TRIALS**). In addition, dose tapering may help minimize discontinuation symptoms (eg, increase in irritability, urge to smoke, depression, and/or insomnia), observed in up to 3% of patients at the end of treatment.

Special Populations

Psychiatric Patients

Patients with a history of psychiatric symptoms who are attempting to quit smoking should be monitored by their healthcare professional for new or worsened psychiatric events. Those with a current condition should be clinically stable. Patients should be instructed that if they develop worsened or new symptoms, to report these to their healthcare provider, so that dose adjustments of psychiatric medications and/or CHAMPIX may be considered (see also **WARNINGS AND PRECAUTIONS, Special Populations, Psychiatric Patients**).

Patients with Impaired Renal Function:

No dosage adjustment is necessary for patients with mild (estimated creatinine clearance >50 mL/min and ≤ 80 mL/min) to moderate (estimated creatinine clearance ≥ 30 mL/min and ≤ 50 mL/min) renal impairment. For patients who experience intolerable adverse events, dosing may be reduced.

For patients with severe renal impairment, the recommended dose of CHAMPIX is 0.5 mg twice daily. Dosing should begin at 0.5 mg once daily for the first 3 days then increased to 0.5 mg twice daily. Based on insufficient clinical experience with CHAMPIX in patients with end-stage renal disease, treatment is not recommended in this patient population (see also **WARNINGS AND PRECAUTIONS, Special Populations: Renal Impairment**).

Patients with Hepatic Impairment:

No dosage adjustment is necessary for patients with hepatic impairment.

Patients with Epilepsy, Patients undergoing Chemotherapy, and Patients with GI disturbances such as irritable bowel: The use of CHAMPIX has not been studied in these patient populations (see **WARNINGS AND PRECAUTIONS, Special Populations**).

Dosing in Elderly Patients:

No dosage adjustment is necessary for elderly patients with normal renal function. However, varenicline is known to be substantially excreted by the kidney, and the risk of toxic reactions to this drug may be greater in patients with impaired renal function. Because elderly patients are more likely to have decreased renal function, care should be taken in dose selection, and it may be useful to monitor renal function (see **WARNINGS AND PRECAUTIONS, Special Populations: Geriatrics**).

OVERDOSAGE

Symptoms

Consistent with its pharmacological profile, CHAMPIX resulted in increased incidences of nausea and vomiting when given at doses greater than the recommended dose of 1 mg BID.

Treatment

Varenicline has been shown to be dialyzed in patients with end-stage renal disease (see **ACTION AND CLINICAL PHARMACOLOGY, Special Populations and Conditions: Renal Insufficiency**), however, there is no experience with dialysis following overdose.

For management of a suspected drug overdose, contact your regional Poison Control Centre.

ACTION AND CLINICAL PHARMACOLOGY

Mechanism of Action

The efficacy of CHAMPIX in smoking-cessation is believed to be a result of varenicline's partial agonist activity at the $\alpha 4\beta 2$ nicotinic acetylcholine receptor (ie, agonist activity to a lesser degree than nicotine), while simultaneously preventing nicotine binding (ie, antagonist activity).

In vitro, varenicline binds with higher affinity to the $\alpha 4\beta 2$ receptor subtype than to other common nicotinic receptors (>500-fold $\alpha 3\beta 4$; >3,500-fold $\alpha 7$; >20,000-fold $\alpha 1\beta \gamma \delta$), or to non-nicotinic receptors and transporters (> 2,000-fold).

Electrophysiology studies *in vitro* and neurochemical studies *in vivo* have shown that varenicline acts as a partial agonist at $\alpha 4\beta 2$ nicotinic acetylcholine receptors. In the absence of nicotine, varenicline's agonist activity is at a significantly lower level than nicotine, but sufficient to activate the central nervous mesolimbic dopamine system, believed to be the neuronal mechanism underlying reinforcement and reward experienced upon smoking. In the presence of nicotine, which competes for the same human $\alpha 4\beta 2$ nicotinic acetylcholine receptor (nAChR) binding site, varenicline prevented nicotine from activating the $\alpha 4\beta 2$ receptor, since it has higher affinity for this site and this prevented full stimulation of the central nervous mesolimbic dopamine system.

Varenicline is also a partial agonist at $\alpha 3\beta 4$ receptors, but a full agonist at $\alpha 7$ receptors and a full agonist at 5-HT₃ receptors.

Varenicline has moderate affinity for the 5-HT₃ serotonergic receptor ($K_i=350$ nM), at which it acts as a weak, full agonist ($EC_{50}=0.96$ μ M). Varenicline-induced nausea shortly after dosing, when gastrointestinal levels are predicted to be temporarily high, may be due to activation of this peripheral receptor, in addition to a possible role for peripheral $\alpha 3\beta 4$ and/or central $\alpha 4\beta 2$ nAChRs.

Pharmacokinetics

Table 7. Summary of Mean with Standard Deviation Varenicline Pharmacokinetic Parameters in Adult Male and Female Smokers

	C_{max} (ng/mL)	T_{max}^b (hr)	AUC₀₋₂₄ (ng·h/mL)	t_{1/2} (hr)	Clearance^c (L/hr)	Volume of distribution^c (L)
1.0 mg ^a BID	9.22 (2.05)	3.00 [1.00- 8.00]	194 [†] (42.7)	33.0 [‡] (14.4)	10.4 (25%CV)	337 (50%CV)

^aDerived from three multiple-dose studies (N=103); [†]N=64; [‡]N=46

^bT_{max} presented as median [range]

^cApparent clearance and central volume of distribution estimated from a population PK analysis conducted on pooled data from 1878 subjects (49.2% females); presented as typical value (interindividual coefficient of variation)

Absorption: Maximum plasma concentrations of varenicline occur typically within 3-4 hours after oral administration. Following administration of multiple oral doses of varenicline to healthy volunteers, steady-state conditions were reached within 4 days. Varenicline exhibits linear kinetics when given as single (0.1 to 3 mg) or repeated (1 to 3 mg/day) doses. In a mass balance study, absorption of varenicline is virtually complete after oral administration and systemic availability is high. Oral bioavailability of varenicline is unaffected by food or time-of-day dosing.

Distribution: Plasma protein binding of varenicline is low ($\leq 20\%$) and independent of both age and renal function.

Metabolism: Varenicline tartrate undergoes minimal metabolism, with approximately 92% of recovered drug-related entity in urine being unchanged varenicline. Metabolite profiles (for circulation and urine) were similar for smokers and non-smokers, and are from the following minor routes of metabolism: N-carbonyl glucuronidation, N-formylation and conjugation with a hexose sugar.

Elimination: The elimination half-life of varenicline tartrate is approximately 24 hours. Renal elimination of varenicline is the major elimination route, primarily through glomerular filtration along with active tubular secretion via the organic cationic transporter, OCT2.

Special Populations and Conditions

There were no clinically meaningful differences seen in varenicline tartrate pharmacokinetics due to being elderly, race, gender, smoking status, or use of concomitant medications, as demonstrated in specific pharmacokinetic studies and in population pharmacokinetic analyses.

Pediatrics:

Based on the data submitted and reviewed by Health Canada, the safety and efficacy of CHAMPIX in pediatric patients has not been established; therefore, Health Canada has not authorized an indication for pediatric use.

Two pharmacokinetic studies have been conducted in adolescent smokers, aged 12-17 inclusive: a single dose study (n= 27), and a multiple dose study (n= 72). Pharmacokinetics were approximately dose-proportional over the 0.5 mg to 2 mg daily dose range studied. (see **INDICATIONS AND CLINICAL USE, Special population: Pediatrics**).

Steady-state systemic exposure: In the multiple-dose study, patients were stratified by bodyweight (> 55 kg; ≤ 55 kg), and within each bodyweight group, were randomized into three treatment arms (low dose of varenicline, high dose of varenicline and placebo) using a 2:2:1 randomization scheme. Dosing was as follows:

- >55 kg: 0.5 mg BID (n = 14), 1.0 mg BID (n = 14) and placebo (n = 7);
- ≤ 55 kg 0.5 mg QD (n = 15), 0.5 mg BID (n = 14) and placebo (n= 8).

The dosing period was 14 days, with all arms at target dose by Day 8. Patients were allowed to continue smoking at will throughout the study.

In adolescent patients of bodyweight >55 kg, steady-state systemic exposures, as assessed by AUC (0-24), were consistent with those previously observed in the adult population. In adolescent patients of ≤ 55 kg, steady-state systemic exposure for the 0.5 mg BID was on average approximately 40% higher compared to that previously observed in the adult population.

Individual adverse event terms (MedDRA-coded preferred terms) that were reported in more than one patient taking CHAMPIX and more frequently than for placebo were: nausea (most frequent), headache, vomiting, dizziness, pharyngolaryngeal pain, abdominal pain upper, anorexia, flatulence, abnormal dreams, arthralgia, fatigue, and somnolence. Patients ≤55 kg reported more adverse events than patients > 55 kg.

Mood-related events were reported for three patients of 57 in the CHAMPIX arms (anger, mood swings, irritability; none severe), compared with 0 reports in 15 patients in the placebo arms.

Geriatrics: A combined single and multiple-dose pharmacokinetic study demonstrated that the pharmacokinetics of 1 mg varenicline given once or twice daily to 16 healthy elderly male and female smokers (aged 65-75 years) for 7 consecutive days was similar to that of younger subjects.

Because elderly patients are more likely to have decreased renal function, care should be taken in

dose selection, and it may be useful to monitor renal function (see **DOSAGE AND ADMINISTRATION, Special Populations: Dosing in Elderly Patients**).

Hepatic Insufficiency: Due to the absence of significant hepatic metabolism, varenicline tartrate pharmacokinetics should be unaffected in patients with hepatic insufficiency, except in the case that there is accompanying renal compromise (see **DOSAGE AND ADMINISTRATION**). The potential for clinically meaningful drug interactions between varenicline and metabolic inhibitors/inducers is low.

Renal Impairment: Varenicline tartrate pharmacokinetics were studied in subjects with normal, mild, moderate, severe renal impairment and end-stage renal disease (n=6 per arm), following 0.5 mg once daily administration for 12 days.

Varenicline pharmacokinetics were essentially unchanged in subjects with mild renal impairment (estimated creatinine clearance >50 mL/min and ≤80 mL/min).

In patients with moderate renal impairment (estimated creatinine clearance ≥30 mL/min and ≤50 mL/min), varenicline exposure [AUC_τ] increased 1.5-fold compared with subjects with normal renal function (estimated creatinine clearance >80 mL/min).

In subjects with severe renal impairment (estimated creatinine clearance <30 mL/min), varenicline exposure [AUC_τ] was increased 2.1-fold.

In subjects with end-stage renal disease (ESRD), undergoing a three-hour session of hemodialysis for three days a week, varenicline exposure [AUC_τ] was increased 2.7-fold; varenicline was efficiently removed by hemodialysis (see **DOSAGE AND ADMINISTRATION, Recommended Dose and Dosage Adjustment: Special Populations, Patients with Impaired Renal Function**).

Patients with Cardiovascular Disease

CHAMPIX was evaluated in a randomized, double-blind, placebo-controlled smoking cessation study of subjects aged 35 to 75 years with stable, documented cardiovascular disease (other than or in addition to hypertension) that had been diagnosed for >2 months. Subjects were randomized to CHAMPIX 1 mg BID (n=353) or placebo (n=350) for 12 weeks of treatment and then were followed for 40 weeks post-treatment. Quit rates were in the range of those from studies in the general population of smokers. Adverse events in this study were quantitatively and qualitatively similar to those observed in studies in the general population of smokers, other than cardiovascular-related events (see also **WARNINGS AND PRECAUTIONS, Cardiovascular Events**).

Patients with Chronic Obstructive Pulmonary Disease

CHAMPIX was evaluated in a randomized, double-blind, placebo-controlled smoking cessation study of 499 subjects with mild-to-moderate COPD with post-bronchodilator FEV₁/FVC <70% and FEV₁ ≥50% of predicted normal value, aged > 35 years. Subjects were randomized and treated with CHAMPIX 1 mg BID (n=248) or placebo (n=251) for 12 weeks and then followed for 40 weeks post-treatment. Quit rates were in the range of those from studies in the general

population of smokers. Adverse events in this one-year study were quantitatively and qualitatively similar to those observed in studies in the general population of smokers.

Patients with Stable Schizophrenia or Schizoaffective Disorder (See also below: Neuropsychiatric Safety Study in Subjects with and without a History of Psychiatric Disorder)

CHAMPIX safety and tolerability was assessed in a double-blind study of 128 smokers with stable schizophrenia or schizoaffective disorder, on antipsychotic medication, randomized 2:1 to varenicline (1 mg twice daily) or placebo for 12 weeks with 12-week non-drug follow-up.

Assessments including the Positive and Negative Symptom Scale (PANSS), standard questioning regarding adverse events, and the Columbia Suicide Severity Rating Scale (C-SSRS) occurred weekly through week 13 and at weeks 16, 20 and 24.

Based on adverse event rates, including neuropsychiatric, there were no new safety concerns compared to studies in the general population of smokers. The study discontinuation rate due to neuropsychiatric adverse events in the CHAMPIX arm was 4% (3 /84), compared to 0 (0 /43) in the placebo group.

In this study, there was no overall worsening of schizophrenia in either treatment group as measured by PANSS scores nor worsening of extra-pyramidal signs.

Evaluation of suicidal ideation and behavior (including C-SSRS): Reported lifetime history of suicidality was higher in the patients randomized to the CHAMPIX arm compared to placebo [62% (52 /84) and 51% (22/43) respectively]. During the active treatment period, the rate of C-SSRS endorsement was 11% (9/82) in the CHAMPIX arm and 9% (4/43) in the placebo arm. There were two suicide-related actions by two patients treated with CHAMPIX (attempt through overdose, and preparatory act of collecting pills); both patients had a lifetime history of similar behaviours.

During the 12 week post-treatment phase, the rate of C-SSRS endorsement decreased in the placebo arm to 5% (2/39), while the rate in the CHAMPIX arm remained at 11% (8 / 70). For six of the cases, all in the CHAMPIX arm, the C-SSRS endorsements were the first in the study for those individuals and occurred more than 30 days after last treatment dose.

All incidences of suicidal ideation or behavior during the study, except for one patient treated with CHAMPIX, occurred in patients with a prior history of suicidality.

Patients with Major Depressive Disorder (See also below: Neuropsychiatric Safety Study in Subjects with and without a History of Psychiatric Disorder)

CHAMPIX was evaluated in a randomized, double-blind, placebo-controlled study of 525 subjects with major depressive disorder without psychotic features (DSM-IV TR), on stable antidepressant treatment and/or who experienced a major depressive episode (which was successfully treated) in the past 2 years. Subjects aged 18 to 75 years were randomized to CHAMPIX 1 mg BID (n=256) or placebo (n=269) for a treatment of 12 weeks and then followed for 40 weeks post-treatment. Quit rates in this study were in the range of those from studies in

the general population of smokers.

In general, the adverse events in this one-year study were quantitatively and qualitatively similar to those observed in studies in the general population of smokers.

The following psychiatric AEs were more frequent in the CHAMPIX group vs placebo: agitation (6.6% vs. 4.1%), depression (6.6% vs. 4.8%), tension (3.5% vs. 3.0%), hostility (2.0% vs. 0.4%) and restlessness (2.0% vs. 1.9%). No overall worsening of depression was observed during the study in neither CHAMPIX or placebo treatment groups.

The percentage of subjects with suicidal ideation and/or behavior during treatment were 6.0% and 7.5% respectively for the CHAMPIX and placebo groups and 6.2% vs 5.8% for the non-treatment follow-up period. There was one event of intentional self-injury/possible suicide attempt during treatment (Day 73) in a subject with history of alcohol abuse in the placebo group. A possible suicide could not be ruled out in one subject who died by an overdose of illicit drugs 76 days after last dose of study drug in the CHAMPIX group.

Neuropsychiatric Safety Study in Subjects with and without a History of Psychiatric Disorder (see also WARNING AND PRECAUTIONS, Psychiatric Symptoms in Patients with and without Pre-existing Psychiatric Disorder or Symptoms)

CHAMPIX was evaluated in a randomized, double-blind, active and placebo-controlled study that included subjects with a history of psychiatric disorder (psychiatric cohort, N=4074) and subjects without a history of psychiatric disorder (non-psychiatric cohort, N=3984). Excluded psychiatric disorders included current substance abuse, dementias, impulse control and dissociative disorders. Subjects aged 18-75 years, smoking 10 or more cigarettes per day were randomized 1:1:1:1 to varenicline 1 mg BID, bupropion SR 150 mg BID, nicotine replacement therapy patch (NRT) 21 mg/day with taper or placebo for a treatment period of 12 weeks; they were then followed for another 12 weeks post-treatment.

The prospective primary safety endpoint was a composite of the following neuropsychiatric (NPS) adverse events (which mapped from 261 MedDRA preferred terms): severe events of anxiety, depression, feeling abnormal, or hostility; and moderate or severe events of agitation, aggression, delusions, hallucinations, homicidal ideation, mania, panic, paranoia, psychosis, suicidal ideation, suicidal behavior or completed suicide.

The primary diagnoses in the psychiatric cohort of the study were: Affective Disorders ~70%; Anxiety Disorders ~19%; Psychotic Disorders ~ 10%, and Borderline Personality Disorders ~ 1% with all patients judged to be clinically stable.

Table 8 shows the rates of the composite NPS adverse event primary end point by treatment group and the risk differences (RDs) (95% CI) vs placebo in each of the non-psychiatric and psychiatric cohort.

Table 8. Rates of Patients Reporting the Composite NPS AE Primary Endpoint by Treatment Group in Both Patient Cohorts

	Non-psychiatric Cohort N=3984			
	CHAMPIX	Bupropion	NRT	Placebo
Number of Patients Treated	990	989	1006	999
Composite NPS AE Primary Endpoint, % (n)	1.3% (13)	2.2% (22)	2.5% (25)	2.4% (24)
RD (95% CI) vs Placebo	-1.28 (-2.40, -0.15)	-0.08 (-1.37, 1.21)	-0.21 (-1.54, 1.12)	
	Psychiatric Cohort N=4074			
	CHAMPIX	Bupropion	NRT	Placebo
Number of Patients Treated	1026	1017	1016	1015
Composite NPS AE Primary Endpoint, % (n)	6.5% (67)	6.7% (68)	5.2% (53)	4.9% (50)
RD (95% CI) vs Placebo	1.59 (-0.42, 3.59)	1.78 (-0.24, 3.81)	0.37 (-1.53, 2.26)	

NRT=Nicotine replacement therapy patch; AE=adverse event; RD = Risk Difference; CI = Confidence Interval.

In the psychiatric cohort, there were more events reported in patients in each treatment group compared with the non-psychiatric cohort, and the incidence of events in the composite endpoint was higher for each of the active treatments compared to placebo.

However, in neither cohort (psychiatric or non-psychiatric) was the use of varenicline or bupropion associated with a significantly increased risk, compared with placebo, of NPS primary endpoint AEs (95% CIs were lower than or included zero).

Various sensitivity analyses were performed, including different expansions of the selected AE definitions. The sensitivity analyses did not reveal significantly increased rates of psychiatric adverse events for CHAMPIX compared to placebo, nor compared to the two other treatments (bupropion, NRT).

The totality of psychiatric adverse events in the study is shown below (Table 9) for reference.

Table 9. Incidence of Adverse Events Coding to Preferred Terms in the Psychiatric Disorder System Organ Class (SOC) and/or Preferred Terms Pre-specified for the Primary NPS Endpoint

Cohort	CHAMPIX	Bupropion	NRT	Placebo
Totality of Psychiatric Adverse Events (All Causality, Any Severity)				
Non-psychiatric	32%	34%	30%	26%
Psychiatric	40%	43%	42%	35%
High Level Group Terms with Preferred Terms > 2% in any treatment group:				
Anxiety disorder & symptoms				
Non-psychiatric	9%	11%	8%	9%
Psychiatric	15%	18%	16%	13%
Depressed Mood Disorder and disturbances				
Non-psychiatric	6%	3%	4%	5%
Psychiatric	11%	11%	11%	11%
Mood Disorder and disturbances NEC				
Non-psychiatric	6%	4%	6%	4%
Psychiatric	8%	7%	8%	9%
Sleep disorders & disturbances				
Non-psychiatric	21%	22%	22%	14%
Psychiatric	22%	23%	26%	15%

Suicidality

The percentage of subjects with suicidal ideation and/or behavior based on the Columbia-Suicide Severity Rating Scale (C-SSRS) was similar between the varenicline and placebo groups for both the non-psychiatric and psychiatric cohort, both during treatment and in the non-treatment follow-up, as shown in Table 10.

There was one completed suicide, which occurred during treatment in a subject treated with placebo, in the non-psychiatric cohort.

Table 10. Number of Patients Reporting Suicidal Ideation and/or Behavior on C-SSRS by Treatment Group in Both Patient Cohorts

	Non-psychiatric Cohort N=3984			
	CHAMPIX N=990 n (%)	Bupropion N=989 n (%)	NRT N=1006 n (%)	Placebo N=999 n (%)
During treatment				
Number assessed	988	983	996	995
Suicidal behavior and/or ideation	7 (0.7)	4 (0.4)	3 (0.3)	7 (0.7)
Suicidal behavior	0	0	1 (0.1)	1 (0.1)
Suicidal ideation	7 (0.7)	4 (0.4)	3 (0.3)	6 (0.6)
During follow up				
Number assessed	807	816	800	805
Suicidal behavior and/or ideation	3 (0.4)	2 (0.2)	3 (0.4)	4 (0.5)
Suicidal behavior	0	1 (0.1)	0	0
Suicidal ideation	3 (0.4)	2 (0.2)	3 (0.4)	4 (0.5)
	Psychiatric Cohort N=4074			
	CHAMPIX N=1026 n (%)	Bupropion N=1017 n (%)	NRT N=1016 n (%)	Placebo N=1015 n (%)
During treatment				
Number assessed	1017	1012	1006	1006
Suicidal behavior and/or ideation	27 (2.7)	15 (1.5)	20 (2.0)	25 (2.5)
Suicidal behavior	0	1 (0.1)	0	2 (0.2)
Suicidal ideation	27 (2.7)	15 (1.5)	20 (2.0)	25 (2.5)
During follow up				
Number assessed	833	836	824	791
Suicidal behavior and/or ideation	14 (1.7)	4 (0.5)	9 (1.1)	11 (1.4)
Suicidal behavior	1 (0.1)	0	1 (0.1)	1 (0.1)
Suicidal ideation	14 (1.7)	4 (0.5)	9 (1.1)	11 (1.4)

NRT=Nicotine replacement therapy patch

For both the psychiatric and non-psychiatric cohorts, the quit rates for all three treatments (varenicline, bupropion, and NRT patches) were significantly greater than those for placebo. The relative efficacy between treatment arms was evaluated. Quit rates for the non-psychiatric cohort were in the range of those from studies in the general population, as were relative rates between treatments for both cohorts (see **CLINICAL TRIALS**). Comparing the two cohorts, quit rates for the psychiatric cohort were diminished compared to non-psychiatric cohort for all treatment arms, including placebo. These data are limited to 6 months from the start of treatment.

Flexibility in Setting a Quit Date

CHAMPIX was evaluated in a double-blind, placebo-controlled study where patients were instructed to select a quit date between the start of Week 2 of treatment (Day 8) and the end of Week 5 (Day 35) of treatment. It was not required that the quit date be selected prior to starting treatment. Subjects were randomized 3:1 and treated for 12 weeks with CHAMPIX 1 mg BID (n=486) or placebo (n=165) and followed for another 12 weeks post-treatment. Quit rates were in the range of those from studies with a fixed target quit date.

Setting a Quit Date at 12 Weeks of Treatment with a Gradual Reduction in Smoking

CHAMPIX was evaluated in a 52-week double-blind, placebo-controlled trial of subjects who were willing to gradually reduce their smoking over a 12-week period before quitting. Subjects were randomized to either CHAMPIX 1 mg twice daily (n=760) or placebo (n=750) for 24 weeks and followed up post-treatment through week 52. Subjects were instructed to reduce the number of cigarettes smoked by at least 50 percent by the end of the first four weeks of treatment, followed by a further 50 percent reduction from week four to week eight of treatment, with the goal of reaching complete abstinence by 12 weeks. After the initial 12-week reduction phase, subjects continued treatment for another 12 weeks. Quit rates were in the range of those from studies with a target quit date either at 1 week of treatment or between days 8 and 35 of treatment.

The CHAMPIX safety profile in this study was consistent with premarketing studies.

Patients Re-treated with CHAMPIX

CHAMPIX was evaluated in a double-blind, placebo-controlled trial of 494 patients who had made a previous attempt to quit smoking with CHAMPIX, and either did not succeed in quitting or relapsed after treatment. Subjects were randomized 1:1 to CHAMPIX 1 mg BID (n=249) or placebo (n=245) for 12 weeks of treatment and followed for up to 40 weeks post-treatment. Patients included in this study had taken CHAMPIX for a smoking-cessation attempt in the past (for a total treatment duration of a minimum of two weeks), at least three months prior to study entry, and had been smoking for at least four weeks. Quit rates in this study were in the range of those from studies in subjects at their first attempt to quit smoking with CHAMPIX.

Adverse events in this one-year study were quantitatively and qualitatively similar to those from studies in subjects at their first attempt to quit with CHAMPIX.

Pregnant Women

A population-based cohort study compared infants exposed to CHAMPIX *in utero* (N=335) with infants born to mothers who smoked during pregnancy (N=78,412) and infants born to non-smoking mothers (N=806,438). In this study, infants exposed to CHAMPIX *in utero* were no more likely to have major congenital malformations (3.6%) than infants born to mothers who smoked during pregnancy (4.3%) or to non-smoking mothers (4.2%). Similarly, infants exposed to CHAMPIX *in utero*, as compared to infants of smoking and non-smoking mothers, were not at increased risk of stillbirth, (0.3%, 0.5%, 0.3%, respectively), small for gestational age (12.5%, 17.1%, 9.1%), preterm birth (7.5%, 7.9%, 5.8%), or premature rupture of membrane (3.6%, 5.4%, 3.8%).

STORAGE AND STABILITY

Store at room temperature (15–30°C).

DOSAGE FORMS, COMPOSITION AND PACKAGING

CHAMPIX is supplied for oral administration in two strengths:

0.5 mg: capsular biconvex, white to off-white, film-coated tablet debossed with "Pfizer" on one side and "CHX 0.5" on the other side. Each tablet contains 0.5 mg of varenicline (as tartrate). Supplied in high-density polyethylene (HDPE) bottles of 56 tablets and in packs containing blister strips of 11 tablets.

1.0 mg: capsular biconvex, light blue film-coated tablet debossed with "Pfizer" on one side and "CHX 1.0" on the other side. Each tablet contains 1.0 mg of varenicline (as tartrate). Supplied in high-density polyethylene (HDPE) bottles of 56 tablets and in packs containing blister strips of 14 or 28 tablets.

Initial dosing pack: Includes one blister containing both 11 x 0.5 mg and 14 x 1.0 mg tablets and a second blister of 28 x 1.0 mg tablets.

Nonmedicinal ingredients are microcrystalline cellulose, anhydrous dibasic calcium phosphate, croscarmellose sodium, colloidal silicon dioxide and magnesium stearate. The film-coating contains hypromellose, titanium dioxide, polyethylene glycol and triacetin. The 1.0 mg tablet also contains FD&C Blue #2/Indigo Carmine Aluminum Lake as a colouring agent.

PART II: SCIENTIFIC INFORMATION

PHARMACEUTICAL INFORMATION

Drug Substance

Proper name : Varenicline tartrate

Chemical name: 7,8,9,10-tetrahydro-6,10-methano-6*H*-pyrazino[2,3-*h*][3]benzazepine,
(2*R*,3*R*)-2,3-dihydroxybutanedioate (1:1)

Molecular formula: C₁₃H₁₃N₃ • C₄H₆O₆

Molecular weight: 361.35 Daltons

Structural formula:

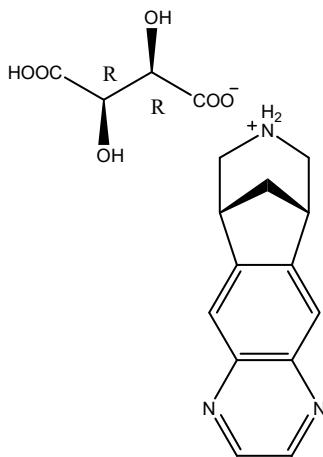

Physicochemical properties: Varenicline tartrate powder is a white to off-white to slightly yellow solid which is highly soluble in water.

CLINICAL TRIALS

The efficacy of CHAMPIX (varenicline tartrate) in smoking-cessation was demonstrated in five double-blind, placebo-controlled clinical trials in which a total of 4190 chronic cigarette smokers (about 10 cigarettes per day) received varenicline. Patients set a date to stop smoking (target quit date, or TQD) of 1 week after treatment initiation. For four of the studies, the primary outcome was based on 12 weeks of drug treatment, with a subsequent 40 weeks of double-blind assessment, post drug-treatment. Of these four, two included a bupropion SR arm. The fifth study assessed the effect of 12 weeks of double-blind treatment on maintenance of abstinence achieved during a prior 12 weeks of open-label varenicline.

The four smoking cessation studies with 12 weeks treatment:

Primary objective: A comparison of varenicline to placebo, and additionally in each of the two studies with a bupropion SR arm comparison of varenicline (1 mg BID) to bupropion SR.

Primary endpoint: Abstinence Responder rate was defined as % of patients for whom 4-week continuous abstinence from Week 9 through Week 12 (4 Week-Continuous Quit Rate, or 4W-CQR) was recorded. Abstinence from smoking was determined on a weekly basis, by patient self-report and measurement of expired carbon monoxide levels (CO). Abstinence was defined as self-report of not even a puff of a cigarette, and by having CO measurements of ≤ 10 ppm. Intent-to-treat population was used, and patients who discontinued drug treatment early were eligible as responders, provided they chose to remain in the study.

Key secondary endpoint: Continuous Abstinence Rate (CAR) was defined as the proportion of all patients who reported that they did not smoke (not even a puff of a cigarette) from Week 9 through to Week 52 (ie, including the 40-week, non-drug treatment period), and had an exhaled CO measurement of ≤ 10 ppm.

Study 1; 12-week randomized dose comparison:

This study compared CHAMPIX 0.5 mg BID (n=253) and 1.0 mg BID (n=253) with placebo (n=121). Each treatment arm had two different regimens - with or without a week of dose titration – in order to explore the effect on tolerability. The titrated and non-titrated groups were pooled for efficacy analysis.

Study 2; 12-week flexible dose study:

This study (n=312) examined the effect of patient-directed dosing strategy of CHAMPIX or placebo. After an initial one week titration to a dose 0.5 mg BID, patients could adjust their dosage as often as they wished between 0.5 mg QD to 1.0 mg BID. Sixty-nine percent (69%) of patients titrated to the maximum allowable dose at any time during the study. For 44% of patients, the modal dose selected was 1.0 mg BID; for 52% of the study patients, the modal dose selected was 1.0 mg/day or less.

Study 3 and Study 4; Identical 12-week studies with active comparator arm:

Two identical double-blinded clinical trials prospectively compared the efficacy of CHAMPIX (1.0 mg BID) to placebo, and to sustained release bupropion (150 mg BID) in the absence of

NRT in smoking-cessation. Patients received treatment for 12 weeks and then were followed for a total study duration of 52 weeks. The CHAMPIX dosage of 1.0 mg BID was achieved using a titration of 0.5 mg once daily for the initial 3 days followed by 0.5 mg BID for the next 4 days. The bupropion dosage of 150 mg BID was achieved using a 3-day titration of 150 mg once daily.

Study Results

Primary Endpoint

In all four studies, the primary endpoint for CHAMPIX (ie, 4W-CQR from Week 9 to Week 12) demonstrated statistical superiority to placebo and in the subset of the two identical studies, statistical superiority to bupropion SR was also demonstrated with CHAMPIX 1.0 mg BID dose. No patients were allowed to use NRT during the drug treatment phase, and those who did were considered treatment failures. The 4W-CQR (weeks 9-12) for all four studies are shown in Table 11.

Table 11. Continuous Quit Rate, Week 9 through 12 across different studies

Studies	CHAMPIX 0.5 mg BID	CHAMPIX 1.0 mg BID	CHAMPIX Flexible	Bupropion SR	Placebo
Study 1	45%* n=253	51%* n=253			12% n=121
Study 2			40%* n=157		12% n=155
Study 3		44%*# n=349		30% ^{†a} n=329	17% n=344
Study 4		44%*# n=343		30% ^{†a} n=340	18% n=340

* P<0.0001 CHAMPIX vs placebo

[†] P<0.001 Bupropion SR vs placebo

P<0.0001 CHAMPIX 1.0 mg BID vs Bupropion SR

^a Statistical comparison of bupropion SR vs placebo was not protocol-specified.

Figure 1. Continuous Quit Rate, Week 9 through 12 across different studies

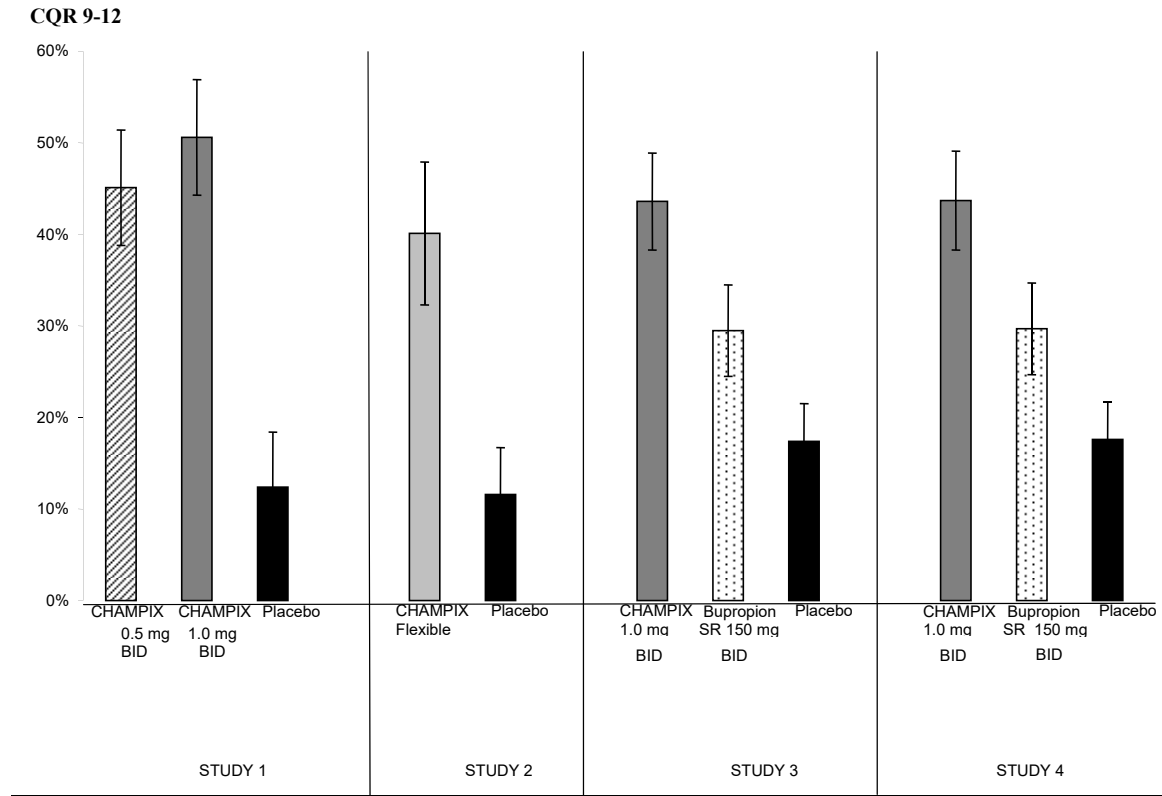

Secondary Endpoints:

In all four studies, a key secondary endpoint for CHAMPIX (ie, CAR Week 9 through 52) demonstrated statistical superiority to placebo. The CAR Weeks 9 through 52 for all four studies are shown in Table 12.

Table 12. Continuous Abstinence Rate, Week 9 through 52 across different studies

Studies	CHAMPIX 0.5 mg BID	CHAMPIX 1.0 mg BID	CHAMPIX Flexible	Bupropion SR	Placebo
Study 1	19%* n=253	22.9%* n=253			4.1% n=121
Study 2			22.3%* n=157		7.7% n=155
Study 3		22.1%* n=349		16.4% ^{† a} n=329	8.4% n=344
Study 4		23%* n=343		15% ^a n=340	10.3% n=340

* P<0.0001 CHAMPIX vs placebo

† P<0.001 Bupropion SR vs placebo

^a Statistical comparison of bupropion SR vs placebo was not protocol-specified.

Figure 2. Continuous Abstinence Rate, Week 9 through 52 across different studies

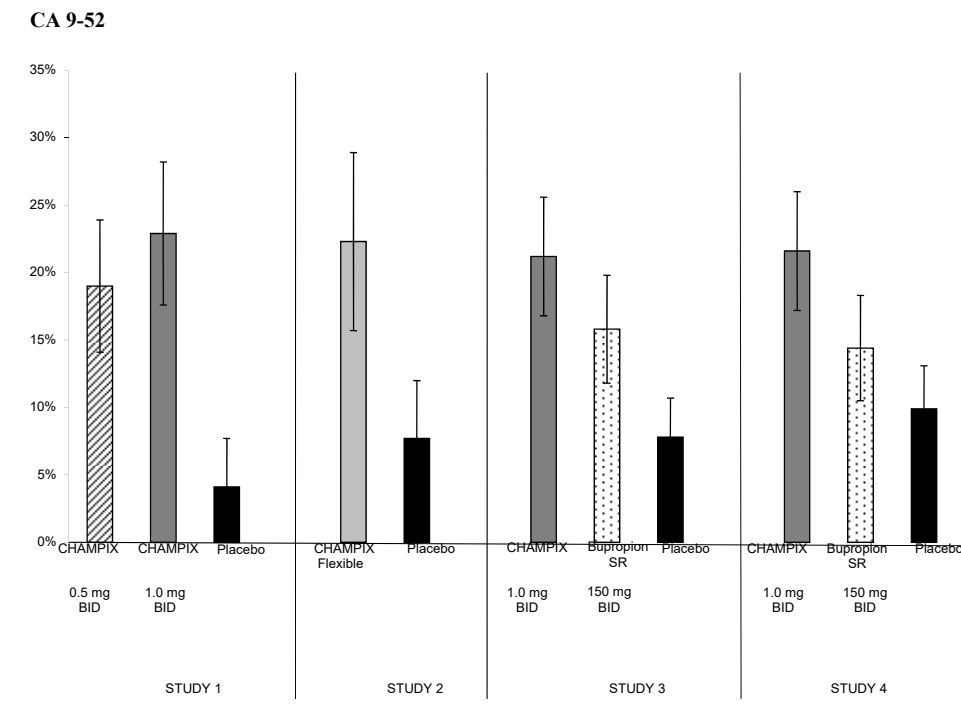

Urge to Smoke and Withdrawal Symptoms

Based on the responses to the Brief Questionnaire of Smoking Urges and the Minnesota Nicotine Withdrawal Scale, as measured in the 12-week treatment period, craving and urge to smoke were significantly reduced in patients randomized to CHAMPIX compared to those randomized to placebo, as were negative affect withdrawal symptoms (depressed mood; irritability, frustration, or anger; anxiety; difficulty concentrating).

Maintenance of Abstinence Study

The fifth study assessed the benefit of an additional 12 weeks of CHAMPIX therapy on the maintenance of abstinence. Patients received open-label CHAMPIX 1.0 mg BID for 12 weeks. Patients who were abstinent for 7 continuous days at Week 12 were then randomized to double-blind treatment with either CHAMPIX (1.0 mg BID, n=602) or placebo (n=604) for an additional 12 weeks, and then followed for a total study duration of 52 weeks.

The primary study endpoint was the CO-confirmed-CAR (defined as above) from Week 13 through Week 24 in the double-blind treatment phase. A key secondary endpoint was the CAR for Week 13 through Week 52.

Superiority to placebo was shown for both the primary and secondary endpoints (see Table 9). The CAR from Week 13 through Week 24 was higher for patients continuing treatment with CHAMPIX (70.6%) than for patients switching to placebo (49.8%). Superiority to placebo was also maintained during the 28-week, post-treatment follow-up (CHAMPIX 44.0% versus placebo 37.1% at Week 52). This study showed the benefit of an additional 12 weeks of treatment with CHAMPIX 1.0 mg BID for the maintenance of smoking-cessation, compared to placebo. A statistically significant difference was maintained at Week 52, the final week of the study.

Table 13. Maintenance Study Results

	CHAMPIX N=602 (%)	Placebo N=604 (%)
CAR wk 13-24	70.6*	49.8
CAR wk 13-52	44.0**	37.1

* P<0.0001 CHAMPIX vs placebo

** P<0.01 CHAMPIX vs placebo

(CAR) continuous abstinence rate

Figure 3. Continuous Abstinence Rate from Week 13 through Week 52 Maintenance Study

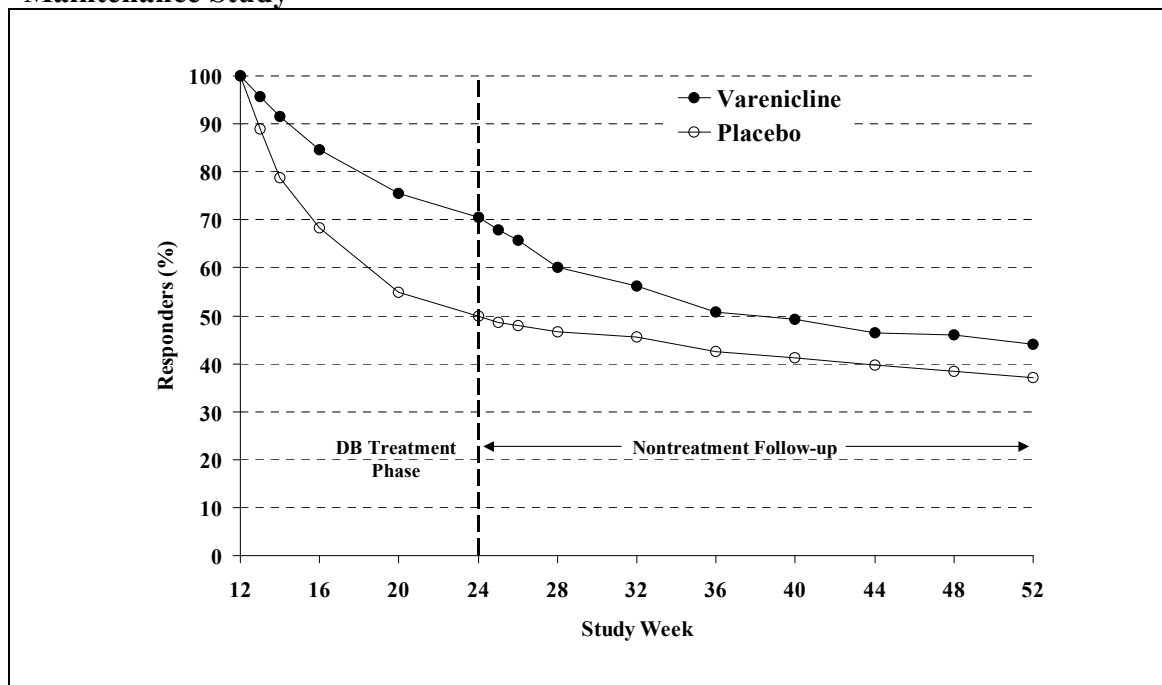

Note: Subjects at Week 12 were those who were abstinent during the last week of open-label varenicline treatment and were randomized and received treatment in the double-blind phase.

DETAILED PHARMACOLOGY

Preclinical Pharmacology

In vitro and *in vivo* experiments demonstrate that varenicline performs as expected for a partial agonist of the $\alpha 4\beta 2$ nicotinic receptor subtype. For example, dopamine turnover and microdialysis results in rats demonstrate that varenicline has a reduced ability to activate the mesolimbic dopamine system relative to nicotine, and in fact varenicline can attenuate the activating effects of nicotine on this system. While varenicline does substitute for nicotine in a discrimination paradigm, varenicline was shown to be less reinforcing than nicotine in rats trained to self-administer nicotine, and pretreatment with varenicline significantly decreased nicotine self-administration. Finally, in a withdrawal study in rats and a study assessing withdrawal in monkeys there were no observed behaviors or responses consistent with withdrawal effects.

In vivo and *in vitro* data demonstrate that varenicline is well absorbed after oral administration. Protein binding of varenicline is low and similar across species. It readily distributes throughout the body with increased but reversible association with melanin-containing tissues. Varenicline was shown to not interact with major human drug metabolizing CYPs. A substantial portion (75% - 93% of dose) of varenicline was excreted as unchanged drug in all species examined, with most drug-related material excreted in urine. Metabolites were minor and those observed in human circulation and excreta were also observed in one or more animal species. *In vitro* data

suggest that renal excretion of varenicline occurs by both passive filtration and an active transport process (likely via renal transporter OCT2).

TOXICOLOGY

The toxicology program was conducted to characterize the toxicity and dose response in the appropriate nonclinical species of the rat and monkey. No evidence of any unique toxicity or adverse pharmacological effects of varenicline in the expected range of human plasma exposure was observed in animals.

Acute and Repeated-Dose Toxicity

The toxicology program was conducted to characterize the toxicity and dose response in the appropriate nonclinical species of the rat and monkey. Effects were seen primarily in the gastrointestinal tract and the central nervous system (CNS) ie, tremors and convulsions at exposure multiples greater than those observed in humans. These changes were reversible.

Acute Toxicity

Acute oral studies in rat (30, 100, 200, and 300 mg/kg) and monkey (3 mg/kg) and intravenous (IV) studies in monkeys (0.08-0.3 mg/kg) were conducted.

In the single-dose study in rats, the findings were in the gastrointestinal system (decreased body weight and loose stool) and CNS (tremors and convulsions). The onset of the CNS clinical signs was rapid and occurred immediately to 2.5 hours post-dosing. All findings were reversed by the end of the 14-day observation period. There was one death in rats dosed at 300 mg/kg PO, a dose associated with exposure approximately 300-fold above expected human exposure.

The single-dose no observed adverse effect level (NOAEL) in monkeys was 0.2 mg/kg (0.1 mg/kg BID) corresponding to an exposure of approximately 1.2-fold above expected human exposure. In a single-dose oral study in monkeys at 3 mg/kg, the findings were also in the gastrointestinal system (emesis) and CNS (tremors). In addition electrocardiogram changes (decreased HR and QT interval and increased PRQ and P wave) were observed. Clinical signs (emesis and tremors) occurred at similar exposures after both oral gavage and IV dosing, both associated with exposure approximately 2- to 4-fold above expected human exposure. All of the findings occurred within ~1-4 hours post-dosing and were not present the next day.

Table 14. Repeat-Dose Gavage Pivotal Studies in Rats and Monkeys

Species	Duration	Dose (mg/kg/day)
Rats	6 Weeks	0.3, 3, 30
	3 Months	3, 10, 30
	6 Months	3, 10, 30
Monkeys	6 Weeks	0.01, 0.05, 0.2 (0.1 BID)
	3 Months	0.01, 0.05, 0.2 (0.1 BID)
	9 Months	0.01, 0.05, 0.2 (0.1 BID)
	9 Months	0.2 (0.1 BID), 0.4 (0.2 BID), 1.2 (0.6 BID)

Rats:

The no-observed adverse effect level (NOAEL) in rats was 10 mg/kg/day in the 3- and 6-month studies, which corresponds to C_{max} and AUC values that are 68 and 50 times those at the maximum recommended human dose (MRHD), respectively. The NOAELs in both studies were based on decreases in body weight and food consumption, which were attributed to decreases in gastric motility.

In the 6-week and 3-month rat studies at 30 mg/kg/day (associated with exposures of approximately 75- to 140-fold above expected human exposure) the findings were in the gastrointestinal tract; decreases in body weight, food consumption, and intestinal dilatation, which were consistent with decreases in gastric motility. At ≥ 10 mg/kg/day (associated with exposures of approximately 40- to 65-fold above expected human exposure), there were slight increases in alkaline phosphatase (ALP), alanine transaminase (ALT), and/or total bilirubin. In addition, hepatocellular single-cell necrosis was observed in a 10 day study, at 100 mg/kg/day. At ≥ 30 mg/kg/day, there were slight increases in hematocrit and hemoglobin. Similar changes were seen in mice and other rat studies, but not monkeys. The changes may be secondary to stress of decreased food consumption and dehydration.

In the 6-month rat study, findings were also in the gastrointestinal tract (decreases in body weight and food consumption). In this study, there were no biologically meaningful hepatic changes as compared to the marginal hepatic findings observed in the shorter-term studies.

Monkeys:

The NOAEL in cynomolgus monkeys was 0.2 mg/kg/day (0.1 mg/kg BID) in the first 9-month study. There were also no findings in the second 9-month study at this dose, which was the low dose. The next dose up (0.4 mg/kg/day) showed sporadic emesis and loose stools. The C_{max} and AUC at 0.2 mg/kg/day in monkeys was approximately 3-fold the human exposure at MRHD.

There were no findings in the 6-week, 3-month, or the first 9-month study, at doses up to 0.2 mg/kg/day.

In the second 9-month monkey study, the main finding at 0.4 mg/kg/day (0.2 mg/kg BID) was sporadic emesis. One female monkey was found dead at this dose of megacolon, secondary to colonic torsion and ischemic necrosis. Megacolon is an uncommon spontaneous finding in monkeys. This finding was likely secondary to the gastrointestinal dysfunction (loose stools) that was evident prior to and during treatment, although drug treatment cannot be excluded. Colonic torsion was not observed in other monkeys with equivalent or higher doses. At 1.2 mg/kg/day (0.6 mg/kg BID) – approximately 10- to 12-fold above expected human exposure – all animals were euthanized or removed from study after 3-8 weeks of treatment due to body weight loss (>15% in 10 of 12 monkeys) associated with emesis and decreased food consumption. Decreases in core body temperature of 1-2 degrees Celsius were observed (and had also been seen in an earlier monkey study at 0.6 mg/kg/day, and were also seen in mice; body temperature perturbation is a well-known effect of nicotine). There were no treatment-related microscopic findings in any of the animals. Dosing was discontinued and the surviving animals at 1.2 mg/kg/day (0.6 mg/kg BID) were monitored for ~1 month. The clinical signs ceased and body weight returned to pretreatment levels within a month.

Carcinogenesis: Lifetime carcinogenicity studies were performed in CD-1 mice and Sprague-Dawley rats. There was no evidence of a carcinogenic effect in mice administered varenicline by oral gavage for 2 years at doses up to 20 mg/kg/day (47 times the maximum recommended human daily exposure based on the area under the curve (AUC)). Rats were administered varenicline (1, 5, and 15 mg/kg/day) by oral gavage for 2 years. In male rats (n=65 per sex per dose group), incidences of hibernoma (tumor of the brown fat) was increased at the mid dose (1 tumor, 5 mg/kg/day, 23 times the maximum recommended human daily exposure based on AUC) and at the maximum dose (2 tumors, 15 mg/kg/day, 67 times the maximum recommended human daily exposure based on AUC). The clinical relevance of this finding to humans has not been established. There was no evidence of carcinogenicity in female rats.

Mutagenesis: Varenicline was not genotoxic, with or without metabolic activation, in the following assays: Ames bacterial mutation assay; mammalian CHO/HGPRT assay; and tests for cytogenetic aberrations *in vivo* in rat bone marrow and *in vitro* in human lymphocytes.

Sexual Function / Reproduction

Impairment of Fertility: There was no evidence of impairment of fertility in either male or female Sprague-Dawley rats administered varenicline succinate up to 15 mg/kg/day (67 and 36 times, respectively, the maximum recommended human daily exposure based on AUC at 1.0 mg BID). However, a decrease in fertility was noted in the offspring of pregnant rats who were administered varenicline succinate at an oral dose of 15 mg/kg/day (36 times the maximum recommended human daily exposure based on AUC at 1.0 mg BID). This decrease in fertility in the offspring of treated female rats was not evident at an oral dose of 3 mg/kg/day (9 times the maximum recommended human daily exposure based on AUC at 1.0 mg BID).

REFERENCES

Acri JB, Grunberg NE, Morse DE. Effects of nicotine on the acoustic startle reflex amplitude in rats. *Psychopharmacology (Berl)*. 1991;104(2):244-8.

Al-Hachim GM, Mahmoud FA. Prenatal nicotine and CNS development. *Epilepsia*. 1985 Nov-Dec; 26(6):661-5.

American Psychiatric Association. *Diagnostic and Statistical Manual of Mental Disorders*. 5th ed. Washington, DC: American Psychiatric Association; 2013.

Anthenelli RM, Benowitz NL, West R, St Aubin L, McRae T, Lawrence D, Ascher J, Russ C, Krishen A, Evins AE. Neuropsychiatric safety and efficacy of varenicline, bupropion, and nicotine patch in smokers with and without psychiatric disorders (EAGLES): a double-blind, randomised, placebo-controlled clinical trial. *Lancet*. 2016;387(10037):2507-20.

Anthenelli RM, Morris C, Ramey TS, Dubrava SJ, Tsilkos K, Russ C, Yunis C. Effects of varenicline on smoking cessation in adults with stable current or past major depression: A randomized trial. *Ann Intern Med*. 2013;159:390–400.

Baldi A, Santini M, Mellone P, Esposito V, Groeger AM, Caputi M, et al. Mediastinal hibernoma: a case report. *J Clin Pathol*. 2004 Sep;57(9):993-4.

Burstein AH, Fullerton T, Clark DJ, Faessel HM. Pharmacokinetics, safety, and tolerability after single and multiple oral doses of varenicline in elderly smokers. *J Clin Pharmacol*. 2006 Nov;46(11):1234-40.

Cappelleri JC, Bushmakina AG, Baker CL, Merikle E, Olufade AO, Gilbert DG. Revealing the multidimensional framework of the Minnesota nicotine withdrawal scale. *Curr Med Res Opin*. 2005 May;21(5):749-60.

Coe JW, Brooks PR, Vetelino MG, Wirtz MC, Arnold EP, Huang J, et al. Varenicline: an alpha4beta2 nicotinic receptor partial agonist for smoking-cessation. *J Med Chem*. 2005 May 19;48(10):3474-7.

Ebbert JO, Hughes JR, West RJ, Rennard SI, Russ C, McRae TD, Treadow J, Yu C, Dutro MP, Park PW. Effect of varenicline on smoking cessation through smoking reduction: A randomized clinical trial. *JAMA*. 2015;313(7):687-94

Faessel HM, Smith BJ, Gibbs MA, Gobey JS, Clark DJ, Burstein AH. Single-dose pharmacokinetics of varenicline, a selective nicotinic receptor partial agonist, in healthy smokers and nonsmokers. *J Clin Pharmacol*. 2006 Sep;46(9):991-8.

Faessel HM, Gibbs MA, Clark DJ, Rohrbacher K, Stolar M, Burstein AH. Multiple-dose pharmacokinetics of the selective nicotinic receptor partial agonist, varenicline, in healthy smokers. *J Clin Pharmacol*. 2006 Dec;46(12):1439-48.

Faessel H, Ravva P, Williams K. Pharmacokinetics, Safety and Tolerability of Varenicline in Healthy Adolescent Smokers: A Multicenter, Randomized, Double-Blind, Placebo-Controlled Parallel-Group Study. *Clin Ther*. 2009;31(1):177-86.

Gonzales D, Hajek P, Pliamm, Nackerts, Tseng L-J, McRae TD, Treadow J. Retreatment with Varenicline for Smoking Cessation in Smokers Who Have Previously Taken Varenicline: A Randomized, Placebo-Controlled Trial. *Clin Pharmacol Ther*. 2014;96(3): 390-6.

Gonzales D, Rennard SI, Nides M, Oncken C, Azoulay S, Billing CB, Watsky EJ, Gong J, Williams KE, Reeves KR. Varenicline, an alpha4beta2 nicotinic acetylcholine receptor partial agonist, vs sustained-release bupropion and placebo for smoking-cessation: a randomized controlled trial. *JAMA*. 2006 Jul 5;296(1):47-55.

Hughes JR, Keely JP, Niaura RS, Ossip-Klein DJ, Richmond RL, Swan GE. Measures of abstinence in clinical trials: issues and recommendations. *Nicotine Tob Res*. 2003 Feb;5(1):13-25. Erratum in: *Nicotine Tob Res*. 2003 Aug;5(4):603.

Jorenby DE, Hays JT, Rigotti NA, Azoulay S, Watsky EJ, Williams KE, Billing CB, Gong J, Reeves KR. Efficacy of varenicline, an alpha4beta2 nicotinic acetylcholine receptor partial agonist, vs placebo or sustained-release bupropion for smoking-cessation: a randomized controlled trial. *JAMA*. 2006 Jul 5;296(1):56-63. Erratum in: *JAMA*. 2006 Sep 20;296(11):1355.

Lean ME, James WP, Jennings G, Trayhurn P. Brown adipose tissue uncoupling protein content in human infants, children and adults. *Clin Sci (Lond)*. 1986 Sep;71(3):291-7.

Maskos U, Molles BE, Pons S, Besson M, Guiard BP, Guilloux JP, et al. Nicotine reinforcement and cognition restored by targeted expression of nicotinic receptors. *Nature*. 2005 Jul 7;436(7047):103-7.

Nides M, Oncken C, Gonzales D, Rennard S, Watsky EJ, Anziano R, Reeves KR. Smoking-cessation with varenicline, a selective alpha4beta2 nicotinic receptor partial agonist: results from a 7-week, randomized, placebo- and bupropion-controlled trial with 1-year follow-up. *Arch Intern Med*. 2006 Aug 14-28;166(15):1561-8.

Obach RS, Reed-Hagen AE, Krueger SS, Obach BJ, O'Connell TN, Zandi KS, et al. Metabolism and disposition of varenicline, a selective alpha4beta2 acetylcholine receptor partial agonist, in vivo and in vitro. *Drug Metab Dispos*. 2006 Jan;34(1):121-30.

Oncken C, Gonzales D, Nides M, Rennard S, Watsky E, Billing CB, Anziano R, Reeves K. Efficacy and safety of the novel selective nicotinic acetylcholine receptor partial agonist, varenicline, for smoking-cessation. *Arch Intern Med*. 2006 Aug 14-28;166(15):1571-7.

Rennard S, Hughes J, Cinciripini PM, Kralikova E, Raupach T, Arteaga C, St-Aubin LB, Russ C. A randomized placebo-controlled trial of varenicline for smoking cessation allowing flexible quit dates. *Nicotine Tob Res*, 2012 Mar;14(3):343-50.

Rigotti NA, Pipe AL, Benowitz NL, Arteaga C, Garza D, Tonstad S. Efficacy and Safety of Varenicline for Smoking Cessation in Patients With Cardiovascular Disease. A Randomized Trial. *Circulation*, 2010, 121:221-229

Rollema H, Chambers LK, Coe JW, Glowa J, Hurst RS, Lebel LA, et al. Pharmacological profile of the alpha(4)beta(2) nicotinic acetylcholine receptor partial agonist varenicline, an effective smoking-cessation aid. *Neuropharmacology*. 2006 Dec 6; [Epub ahead of print <http://dx.doi.org/10.1016/j.neuropharm.2006.10.016>].

Sell H, Deshaies Y, Richard D. The brown adipocyte: update on its metabolic role. *Int J Biochem Cell Biol*. 2004 Nov;36(11):2098-104.

SRNT Subcommittee on Biochemical Verification. Biochemical verification of tobacco use and cessation. *Nicotine Tob Res*. 2002 May;4(2):149-59.

Tapper AR, McKinney SL, Nashmi R, Schwarz J, Deshpande P, Labarca C, et al. Nicotine activation of alpha4 receptors: sufficient for reward, tolerance, and sensitization. *Science*. 2004 Nov 5;306(5698):1029-32.

Tashkin D.P, Rennard S, Hays JT, Ma W, Lawrence D, and Lee T.C. Effects of varenicline on smoking cessation in mild-to-moderate COPD: A randomized controlled trial. *Chest* 2011; 139(3): 591-599.

Tonstad S, Tonnesen P, Hajek P, Williams KE, Billing CB, Reeves KR; Varenicline Phase 3 Study Group. Effect of maintenance therapy with varenicline on smoking-cessation: a randomized controlled trial. *JAMA*. 2006 Jul 5;296(1):64-71.

Tonstad S, Davies S, Flammer M, Russ C, and Hughes J; Psychiatric Adverse Events in Randomized, Double-Blind, Placebo-Controlled Clinical Trials of Varenicline. *Drug Saf* 2010; 33 (4): 289-301

Ward MM, Swan GE, Jack LM. Self-reported abstinence effects in the first month after smoking-cessation. *Addict Behav*. 2001 May-Jun;26(3):311-27.

West R, Hajek P, Stead L, Stapleton J. Outcome criteria in smoking-cessation trials: proposal for a common standard. *Addiction*. 2005 Mar;100(3):299-303.

Williams JM, Anthenelli RM, Morris CD, et al. A randomized, double-blind, placebo-controlled study evaluation the safety and efficacy of varenicline for smoking cessation in patients with schizophrenia or schizoaffective disorder. *J Clin Psychiatry*. 2012;73(5):654-60.

PART III: CONSUMER INFORMATION
Pr CHAMPIX®
(varenicline tartrate tablets)

Read this information each time you refill your prescription in case new information has been added.

This leaflet is part III of a three-part "Product Monograph" published when CHAMPIX was approved for sale in Canada and is designed specifically for Consumers. This leaflet is a summary and will not tell you everything about CHAMPIX. Contact your doctor or pharmacist if you have any questions about the drug.

What is the most important information I should know about CHAMPIX?

When you try to quit smoking, with or without CHAMPIX, you may have symptoms that may be due to nicotine withdrawal, including

- the urge to smoke
- depressed mood
- trouble sleeping
- irritability
- frustration
- anger
- feeling anxious
- difficulty concentrating
- restlessness
- decreased heart rate
- increased appetite or weight gain.

Some people have even experienced suicidal thoughts when trying to quit smoking without medication. Sometimes quitting smoking can lead to worsening of mental health problems that you already have, such as depression.

Mental Health Problems

Some people have had serious side effects while taking CHAMPIX to help them quit smoking, including changes in behavior or thinking, hostility, agitation, aggression, depressed mood, or suicidal thoughts or actions. These symptoms have occurred in people with previous mental health problems, as well as in those with no previous history. For some people, these symptoms began when they started taking CHAMPIX while for others, they began after several weeks of treatment, or shortly after stopping CHAMPIX.

Before taking any quit-smoking treatment, including CHAMPIX, tell your healthcare provider (doctor, pharmacist or nurse):

- if you have ever had depression or other mental health problems;
- about any concerning symptoms you had during other times you tried to quit smoking, with or without medication.

Inform your friends and family members of your quit attempt with CHAMPIX and ask for their support and help in monitoring for any changes in behavior or thinking that are not normal.

Drinking alcohol may increase the risk of having mental health problems during your treatment with CHAMPIX.

Patients with history of mental health problems (eg depression, anxiety, schizophrenia): If you have had mental health problems before taking CHAMPIX, your healthcare provider will monitor you while you try to quit smoking with CHAMPIX. If you develop worsened or new symptoms, talk to your healthcare provider right away because changing the dose (of CHAMPIX or other medications) may make a difference.

All patients/General: If you have thoughts, moods or behaviours that are severe, concerning or very abnormal for you, stop taking CHAMPIX right away, seek medical help, and tell your healthcare provider about your symptoms. In many people, these symptoms went away after stopping CHAMPIX, but not in all. It is important for you to follow up with your healthcare provider until your symptoms go away.

Allergic Reactions

Some people can have allergic reactions to CHAMPIX. Some of these allergic reactions can be life-threatening and include: swelling of the face, mouth, and throat that can cause trouble breathing. If you have these symptoms, stop taking CHAMPIX and seek immediate emergency medical attention.

Serious Skin Reactions

Some people can have serious skin reactions while taking CHAMPIX. These can include rash, swelling, redness, and peeling of the skin. Some of these reactions can become life-threatening. If you have a rash with peeling skin or blisters in your mouth, around the eyes or genitals, stop taking CHAMPIX and seek immediate emergency medical attention.

ABOUT THIS MEDICATION**What the medication is used for:**

CHAMPIX is a prescription medicine which is used in combination with supportive counselling to help motivated adults stop smoking.

What it does:

CHAMPIX can help to relieve the craving and withdrawal symptoms associated with stopping smoking.

CHAMPIX does not contain nicotine, but it has been shown to affect the nicotine receptor in the brain that is thought to be most related to smoking addiction. CHAMPIX can affect this receptor in two opposite ways: it acts like a weaker version of nicotine, and also blocks nicotine from getting to the receptor because it binds more tightly. Although it is thought that this may be, in part, how CHAMPIX works, it is not known exactly how the drug works in people.

When it should not be used:**Do not take CHAMPIX if you:**

- are allergic (hypersensitive) to varenicline tartrate or any of the other ingredients of CHAMPIX (see list below of non-medical ingredients).
- are using nicotine replacement therapy, such as patches, gum or inhaler. The combination of CHAMPIX and nicotine replacement therapy is not expected to improve your chances of quitting, and may result in more side effects than with CHAMPIX alone.

What the medicinal ingredient is:

Varenicline tartrate.

What the nonmedicinal ingredients are:

The nonmedicinal ingredients are microcrystalline cellulose, anhydrous dibasic calcium phosphate, croscarmellose sodium, colloidal silicon dioxide and magnesium stearate. The film-coating contains hypromellose, titanium dioxide, polyethylene glycol and triacetin. The 1 mg tablet also contains FD&C Blue #2/Indigo Carmine Aluminum Lake as a colouring agent.

What dosage forms it comes in:

CHAMPIX is available as film-coated tablets. The 0.5 mg tablets are white and the 1 mg tablets are light blue.

WARNINGS AND PRECAUTIONS**BEFORE you use CHAMPIX talk to your healthcare provider if you:**

- have experienced depression or any other mental health problems. Your healthcare provider will monitor you for new or worsened emotional or behavioral problems during treatment with CHAMPIX.
- have any problems with your kidneys, as you may need a lower dose of CHAMPIX.
- have heart or blood vessel (cardiovascular) problems.
- have a history of seizures.
- have any other medical conditions.
- are pregnant, are breastfeeding or plan to become pregnant (see “Pregnancy” and “Breastfeeding” below).
- have diabetes. CHAMPIX can potentially affect your blood sugar regulation, and you may need to monitor your blood sugar more often. If you notice changes, discuss this with your healthcare provider.

The effects of changes in your body resulting from stopping smoking, with or without treatment with CHAMPIX, may alter the way other drugs work. Tell your healthcare provider about all your other medicines, including prescription and nonprescription medicines, vitamins and herbal supplements. Especially, tell your healthcare provider if you take:

- o Insulin
- o Asthma medicines (theophylline)
- o Blood thinner (warfarin)

as an adjustment of the dose of these medicines may be necessary once you are smoke-free.

Mental Health Symptoms

See “What is the most important information I should know about CHAMPIX?”

Pregnancy

Talk to your healthcare provider if you are pregnant or planning to become pregnant.

You should not take CHAMPIX while you are pregnant. It is unknown if CHAMPIX will harm your unborn baby.

It is best to stop smoking before you get pregnant.

Breastfeeding

You should ask your healthcare provider for advice before taking any medication, including CHAMPIX, if you are breastfeeding, as the medicine may pass into breast milk.

CHAMPIX is not recommended for use in children under 18 years of age.

Accidental Injury, including while Driving, Operating Machinery

Do not engage in potentially hazardous tasks, such as driving a car or operating dangerous machines, until you know how CHAMPIX may affect you. In some cases, people have reported sleepiness, dizziness, blackouts, seizures or difficulty concentrating while driving.

Seizures

Tell your healthcare provider if you have experienced seizures or have epilepsy before you start CHAMPIX treatment. Some people have reported seizures while taking CHAMPIX, both with and without a history of seizures.

Heart or Stroke Events

New or worse heart or blood vessel (cardiovascular) problems have been reported in people taking CHAMPIX, primarily in those who already have cardiovascular problems. From the information available to date, it is not possible to determine whether CHAMPIX increases the risk of heart or stroke events.

Tell your healthcare provider if you have any changes in cardiovascular symptoms during treatment with CHAMPIX. Get emergency medical help right away if you have symptoms of a heart attack, including any of the following:

- Chest discomfort (uncomfortable pressure, squeezing, fullness or pain) that lasts more than a few minutes, or that goes away and comes back.
- Pain or discomfort in one or both arms, back, neck, jaw or stomach.
- Shortness of breath, sweating, nausea, vomiting, or feeling lightheaded associated with chest discomfort.

Get emergency medical help right away if you have symptoms of a stroke, including any of the following:

- Weakness - Sudden loss of strength or sudden numbness in the face, arm or leg even if temporary.
- Trouble speaking - Sudden difficulty speaking or understanding or sudden confusion, even if temporary.
- Vision problems - Sudden trouble with vision, even if temporary.

- Headache - Sudden severe and unusual headache.
- Dizziness - Sudden loss of balance, especially with any of the above signs.

Sleepwalking

Sleepwalking has been reported in patients taking CHAMPIX, and may sometimes lead to behaviour that is harmful to you or other people or property. Stop taking CHAMPIX and tell your healthcare provider if you start sleepwalking.

INTERACTIONS WITH THIS MEDICATION

Drinking alcohol during treatment with CHAMPIX may increase the risk of mental health symptoms.

Reported experiences include:

- **unusual or sometimes aggressive behavior;**
- **more intoxicated than expected from the amount of alcohol;**
- **no memory of things that have happened.**

Use of CHAMPIX with other therapies for smoking-cessation:

The safety and benefits of taking CHAMPIX in combination with other medicines for stopping smoking have not been studied. Taking CHAMPIX in combination with other smoking-cessation therapies (eg, nicotine replacement therapy) is therefore not recommended. Using CHAMPIX in combination with nicotine replacement therapies (eg, patch gum or inhaler) is not likely to increase your chances of quitting smoking, and it may result in more side effects than with CHAMPIX alone.

PROPER USE OF THIS MEDICATION

You are more likely to stop smoking if you are motivated to stop. Your healthcare provider can provide advice, support and sources of further information to help ensure your attempt to stop smoking is successful.

To increase the chances of success, CHAMPIX should be used in combination with supportive counselling as recommended by your healthcare provider. CHAMPIX was used in combination with supportive counselling in the clinical trials. At any time, you can also call government-funded toll-free provincial Quit Lines, to speak to a knowledgeable and supportive specialist; these phone numbers are available on the Health Canada website, or by calling 1-800-CHAMPIX.

Always take CHAMPIX exactly as your healthcare provider has told you. You should check with your healthcare provider if you are not sure.

REMEMBER: This medication has been prescribed specifically for you. Do not give it to anyone else.

Setting Your Quit Date:

Starting treatment before your quit date lets CHAMPIX build up in your body. You can keep smoking until your quit date.

There are three ways to set your quit date when using CHAMPIX. Talk to your healthcare provider about which way is best for you:

- Fixed quit approach: Set a quit date when you will stop smoking. Start taking CHAMPIX 8 - 14 days (1 to 2 weeks) before your quit date. You should take CHAMPIX for 12 weeks. After 12 weeks of treatment, your healthcare provider may recommend an additional 12 weeks of treatment.

Or

- Flexible quit approach: Start taking CHAMPIX, then quit smoking between Day 8 and Day 35 after the start of your treatment (ie between Weeks 2 and 5). You should take CHAMPIX for 12 weeks. After 12 weeks of treatment, your healthcare provider may recommend an additional 12 weeks of treatment.

Or

- Gradual quit approach: Start taking CHAMPIX and reduce smoking with a goal to quit smoking by end of 12 weeks of treatment. For example, reduce smoking by half by the 4th week, another half by the 8th week (down to 25%) and then quit by the end of the 12th week. You may quit any time before the end of 12 weeks of treatment, if you are able to. Continue treatment for an additional 12 weeks for a total of 24 weeks.

Write down, and keep in a visible or convenient place (for example on the fridge or on the CHAMPIX pack), the date that you started CHAMPIX, your quit date, and the date to stop taking CHAMPIX.

Make sure that you try to stop smoking on your quit date. If you slip-up and smoke after that target date, keep trying. Some people need a few weeks on CHAMPIX for it to work best.

Dosing Options:

CHAMPIX should be taken after eating and with a full glass of water.

Regardless of which dose is prescribed, the first week on CHAMPIX is the same, and is described in the following table:

Week 1 Dosing Schedule:

Day	Dose
Day 1 – 3	Take one white CHAMPIX 0.5 mg tablet once a day.
Day 4 - 7	Take one white CHAMPIX 0.5 mg tablet twice a day, once in the morning and once in the evening, at about the same time each day.

After the first week, your healthcare provider may recommend to stay at 0.5 mg twice a day (**OPTION 1**) or go up to 1 mg twice a day (**OPTION 2**).

Week 2 (day 8) to the end of treatment

OPTION 1: Continue on 0.5 mg twice a day

Day	Dose
Day 8- end of treatment	0.5 mg twice a day: Continue to take one white CHAMPIX 0.5 mg pill in the morning, and one in the evening, at about the same time each day

Or

OPTION 2: Start taking 1 mg twice a day

Day	Dose
Day 8- end of treatment	1 mg twice a day: Take one light blue CHAMPIX 1 mg pill in the morning, and one in the evening, at about the same time each day

The maximum dose of CHAMPIX is 1 mg twice a day.

Based on the limited data available, the two doses do not appear different in terms of either quit rates, or rates of

serious mental health side effects (your healthcare provider can provide more information).

Discussion with your healthcare provider is important in order to choose the dose that is best for you.

If needed, the dose can be changed depending on how well you tolerate CHAMPIX and how effective your healthcare provider and you consider it is in helping you quit smoking. Your healthcare provider will help decide what dose is right for you.

Your healthcare provider may recommend to gradually lower the dose at the end of the treatment period rather than stopping abruptly.

Can I smoke while taking CHAMPIX?

You can keep smoking prior to your quit date.

Smoking after your quit date will reduce your chance of breaking your smoking addiction.

Some people have reported a change in the taste of cigarettes after starting CHAMPIX.

Overdose:

In case of drug overdose, contact a health care practitioner, hospital emergency department or regional Poison Control Centre immediately, even if there are no symptoms.

Missed Dose:

Do not take a double dose to make up for a forgotten tablet. It is important that you take CHAMPIX regularly at the same time each day. If you forget to take a dose, take it as soon as you remember, as long as it is within a few hours of the missed dose. If it is has been longer than a few hours since the missed dose, or if you do not remember whether you took a dose or not, then skip that dose, and wait to take the next dose at the correct time.

If you have any further questions on the use of this product, ask your healthcare provider.

Your appetite may increase, and you may gain some weight.

Like all medicines, CHAMPIX can cause side effects, although not everybody gets them.

The common side effects are mostly mild to moderate and these usually occur in the first weeks of treatment.

Some of the most common side effects you should be aware of include:

- Nausea, vomiting
- Trouble sleeping
- Headache
- Abnormal dreams (vivid, unusual, or increased dreaming; rarely may include nightmares)
- Sleepiness, tiredness, dizziness
- Constipation, diarrhea, gas

Mental Health Problems

See “**What is the most important information I should know about CHAMPIX?**”

Stop taking CHAMPIX if you experience severe or unusual feelings of agitation, aggression, depressed mood, hostility, hallucinations, or if you have thoughts of self-harm or harm to others. Tell your healthcare provider about your symptoms.

Allergic Reactions

Some people have allergic reactions to CHAMPIX. Some of these allergic reactions can be life-threatening and include: swelling of the face, mouth (lips, gums, tongue), and throat can cause trouble breathing. If you have these symptoms, stop taking CHAMPIX and seek immediate emergency medical attention.

Serious Skin Reactions

Some people can have serious skin reactions while taking CHAMPIX. These can include rash, swelling, redness, and peeling of the skin. Some of these reactions can become life-threatening. If you have a rash with peeling skin, or blistering of the mouth, around the eyes or genitals, stop taking CHAMPIX and seek immediate emergency medical attention.

SIDE EFFECTS AND WHAT TO DO ABOUT THEM

Whether you are taking medication to stop smoking or not, the following are symptoms you may feel: depressed, short-tempered, frustrated or angry, nervous, impatient; have difficulty concentrating.

SERIOUS SIDE EFFECTS, HOW OFTEN THEY HAPPEN AND WHAT TO DO ABOUT THEM

Symptom / effect		Talk with your doctor or pharmacist		Stop taking drug and seek immediate emergency medical attention
		Only if severe	In all cases	
Rare	Allergic reaction redness, itching or swelling of your skin, hives, burning, stinging, swelling of the neck area, or any difficulty with breathing, not present before using this medicine			X
Rare	Serious skin reactions peeling of the skin, or rash combined with blisters around the mouth, eyes or genitals.			X
Rare	Mental Health Problems		X	X (if severe, or if involves potential for harm to self or others)
Unknown	Heart attack: chest pain often associated with left shoulder or jaw pain, feeling of constriction around chest and sweating			X

SERIOUS SIDE EFFECTS, HOW OFTEN THEY HAPPEN AND WHAT TO DO ABOUT THEM

Symptom / effect		Talk with your doctor or pharmacist		Stop taking drug and seek immediate emergency medical attention
		Only if severe	In all cases	
Unknown	Stroke: weakness and/or loss of sensation of limbs or face, difficulty speaking, clumsiness, visual loss			X
Unknown	Seizures: Loss of consciousness with uncontrollable shaking (convulsion)			X
Unknown	Sleepwalking		X (and stop taking CHAMPIX)	

This is not a complete list of side effects. For any unexpected effects while taking CHAMPIX, contact your doctor or pharmacist.

HOW TO STORE IT

Store CHAMPIX at room temperature (15°C – 30°C).

Keep out of the reach and sight of children.

REPORTING SUSPECTED SIDE EFFECTS

You can report any suspected adverse reactions associated with the use of health products to the Canada Vigilance Program by one of the following 3 ways:

- Report online at www.healthcanada.gc.ca/medeffect
- Call toll-free at 1-866-234-2345
- Complete a Canada Vigilance Reporting Form and:
 - Fax toll-free to 1-866-678-6789, or
 - Mail to: Canada Vigilance Program
Health Canada
Postal Locator 1908C
Ottawa, Ontario
K1A 0K9

Postage paid labels, Canada Vigilance Reporting Form and the adverse reaction reporting guidelines are available on the MedEffect™ Canada Web site at www.healthcanada.gc.ca/medeffect.

NOTE: Should you require information related to the management of side effects, contact your health professional. The Canada Vigilance Program does not provide medical advice.

MORE INFORMATION

This document plus the full product monograph, prepared for health professionals can be found at:
<http://www.Pfizer.ca>
or by contacting the sponsor, Pfizer Canada Inc., at:
1-800-463-6001

This leaflet was prepared by Pfizer Canada ULC
17,300 TransCanada Highway, Kirkland, Quebec
H9J 2M5

Last revised: January 22, 2019

HIGHLIGHTS OF PRESCRIBING INFORMATION

These highlights do not include all the information needed to use CHANTIX safely and effectively. See full prescribing information for CHANTIX.

CHANTIX® (varenicline) tablets, for oral use

Initial U.S. Approval: 2006

RECENT MAJOR CHANGES

Warnings and Precautions, Cardiovascular Events (5.5) 6/2018

INDICATIONS AND USAGE

CHANTIX is a nicotinic receptor partial agonist indicated for use as an aid to smoking cessation treatment. (1 and 2.1)

DOSAGE AND ADMINISTRATION

- Begin CHANTIX dosing one week before the date set by the patient to stop smoking. Alternatively, the patient can begin CHANTIX dosing and then quit smoking between days 8 and 35 of treatment. (2.1)
- Starting Week: 0.5 mg once daily on days 1-3 and 0.5 mg twice daily on days 4-7. (2.1)
- Continuing Weeks: 1 mg twice daily for a total of 12 weeks. (2.1)
- An additional 12 weeks of treatment is recommended for successful quitters to increase likelihood of long-term abstinence. (2.1)
- Consider a gradual approach to quitting smoking with CHANTIX for patients who are sure that they are not able or willing to quit abruptly. Patients should begin CHANTIX dosing and reduce smoking by 50% from baseline within the first four weeks, by an additional 50% in the next four weeks, and continue reducing with the goal of reaching complete abstinence by 12 weeks. Continue treatment for an additional 12 weeks, for a total of 24 weeks. (2.1)
- Severe Renal Impairment (estimated creatinine clearance less than 30 mL/min): Begin with 0.5 mg once daily and titrate to 0.5 mg twice daily. For patients with end-stage renal disease undergoing hemodialysis, a maximum of 0.5 mg daily may be given if tolerated. (2.2)
- Consider dose reduction for patients who cannot tolerate adverse effects. (2.1)
- Another attempt at treatment is recommended for those who fail to stop smoking or relapse when factors contributing to the failed attempt have been addressed. (2.1)
- Provide patients with appropriate educational materials and counseling to support the quit attempt. (2.1)

DOSAGE FORMS AND STRENGTHS

Tablets: 0.5 mg and 1 mg (3)

CONTRAINDICATIONS

History of serious hypersensitivity or skin reactions to CHANTIX. (4)

WARNINGS AND PRECAUTIONS

- **Neuropsychiatric Adverse Events:** Postmarketing reports of serious or clinically significant neuropsychiatric adverse events have included changes in mood (including depression and mania), psychosis, hallucinations, paranoia, delusions, homicidal ideation, aggression, hostility, agitation, anxiety, and panic, as well as suicidal ideation, suicide

attempt, and completed suicide. Observe patients attempting to quit smoking with CHANTIX for the occurrence of such symptoms and instruct them to discontinue CHANTIX and contact a healthcare provider if they experience such adverse events. (5.1)

- **Seizures:** New or worsening seizures have been observed in patients taking CHANTIX. CHANTIX should be used cautiously in patients with a history of seizures or other factors that can lower the seizure threshold. (5.2)
- **Interaction with Alcohol:** Increased effects of alcohol have been reported. Instruct patients to reduce the amount of alcohol they consume until they know whether CHANTIX affects them. (5.3)
- **Accidental Injury:** Accidental injuries (e.g., traffic accidents) have been reported. Instruct patients to use caution driving or operating machinery until they know how CHANTIX may affect them. (5.4)
- **Cardiovascular Events:** Patients with underlying cardiovascular (CV) disease may be at increased risk of CV events; however, these concerns must be balanced with the health benefits of smoking cessation. Instruct patients to notify their healthcare providers of new or worsening CV symptoms and to seek immediate medical attention if they experience signs and symptoms of myocardial infarction (MI) or stroke. (5.5 and 6.1)
- **Somnambulism:** Cases of somnambulism have been reported in patients taking CHANTIX. Some cases described harmful behavior to self, others, or property. Instruct patients to discontinue CHANTIX and notify their healthcare provider if they experience somnambulism. (5.6 and 6.2)
- **Angioedema and Hypersensitivity Reactions:** Such reactions, including angioedema, infrequently life-threatening, have been reported. Instruct patients to discontinue CHANTIX and immediately seek medical care if symptoms occur. (5.7 and 6.2)
- **Serious Skin Reactions:** Rare, potentially life-threatening skin reactions have been reported. Instruct patients to discontinue CHANTIX and contact a healthcare provider immediately at first appearance of skin rash with mucosal lesions. (5.8 and 6.2)
- **Nausea:** Nausea is the most common adverse reaction (up to 30% incidence rate). Dose reduction may be helpful. (5.9)

ADVERSE REACTIONS

Most common adverse reactions (>5% and twice the rate seen in placebo-treated patients) were nausea, abnormal (e.g., vivid, unusual, or strange) dreams, constipation, flatulence, and vomiting. (6)

To report SUSPECTED ADVERSE REACTIONS, contact Pfizer Inc. at 1-800-438-1985 or FDA at 1-800-FDA-1088 or www.fda.gov/medwatch.

DRUG INTERACTIONS

- **Other Smoking Cessation Therapies:** Safety and efficacy in combination with other smoking cessation therapies has not been established. Coadministration of varenicline and transdermal nicotine resulted in a high rate of discontinuation due to adverse events. (7.1)
- **Effect of Smoking Cessation on Other Drugs:** Pharmacokinetics or pharmacodynamics of certain drugs (e.g., theophylline, warfarin, insulin) may be altered, necessitating dose adjustment. (7.2)

See 17 for PATIENT COUNSELING INFORMATION and Medication Guide

Revised: 02/2019

FULL PRESCRIBING INFORMATION: CONTENTS*

- 1 INDICATIONS AND USAGE**
- 2 DOSAGE AND ADMINISTRATION**
 - 2.1 Usual Dosage for Adults
 - 2.2 Dosage in Special Populations
- 3 DOSAGE FORMS AND STRENGTHS**
- 4 CONTRAINDICATIONS**
- 5 WARNINGS AND PRECAUTIONS**
 - 5.1 Neuropsychiatric Adverse Events including Suicidality
 - 5.2 Seizures
 - 5.3 Interaction with Alcohol
 - 5.4 Accidental Injury
 - 5.5 Cardiovascular Events
 - 5.6 Somnambulism
 - 5.7 Angioedema and Hypersensitivity Reactions
 - 5.8 Serious Skin Reactions
 - 5.9 Nausea
- 6 ADVERSE REACTIONS**
 - 6.1 Clinical Trials Experience
 - 6.2 Postmarketing Experience
- 7 DRUG INTERACTIONS**
 - 7.1 Use with Other Drugs for Smoking Cessation
 - 7.2 Effect of Smoking Cessation on Other Drugs
- 8 USE IN SPECIFIC POPULATIONS**
 - 8.1 Pregnancy
 - 8.2 Lactation
 - 8.4 Pediatric Use
 - 8.5 Geriatric Use
 - 8.6 Renal Impairment
- 9 DRUG ABUSE AND DEPENDENCE**
 - 9.1 Controlled Substance
 - 9.3 Dependence
- 10 OVERDOSAGE**
- 11 DESCRIPTION**
- 12 CLINICAL PHARMACOLOGY**
 - 12.1 Mechanism of Action
 - 12.3 Pharmacokinetics
- 13 NONCLINICAL TOXICOLOGY**
 - 13.1 Carcinogenesis, Mutagenesis, Impairment of Fertility
- 14 CLINICAL STUDIES**
 - 14.1 Initiation of Abstinence
 - 14.2 Urge to Smoke
 - 14.3 Long-Term Abstinence
 - 14.4 Alternative Instructions for Setting a Quit Date
 - 14.5 Gradual Approach to Quitting Smoking
 - 14.6 Re-Treatment Study
 - 14.7 Subjects with Chronic Obstructive Pulmonary Disease
 - 14.8 Subjects with Cardiovascular Disease and Other Cardiovascular Analyses
 - 14.9 Subjects with Major Depressive Disorder
 - 14.10 Postmarketing Neuropsychiatric Safety Outcome Trial
- 16 HOW SUPPLIED/STORAGE AND HANDLING**
- 17 PATIENT COUNSELING INFORMATION**

*Sections or subsections omitted from the full prescribing information are not listed.

FULL PRESCRIBING INFORMATION

1 INDICATIONS AND USAGE

CHANTIX is indicated for use as an aid to smoking cessation treatment.

2 DOSAGE AND ADMINISTRATION

2.1 Usual Dosage for Adults

Smoking cessation therapies are more likely to succeed for patients who are motivated to stop smoking and who are provided additional advice and support. Provide patients with appropriate educational materials and counseling to support the quit attempt.

The patient should set a date to stop smoking. Begin CHANTIX dosing one week before this date. Alternatively, the patient can begin CHANTIX dosing and then quit smoking between days 8 and 35 of treatment.

CHANTIX should be taken orally after eating and with a full glass of water.

The recommended dose of CHANTIX is 1 mg twice daily following a 1-week titration as follows:

Days 1 – 3:	0.5 mg once daily
Days 4 – 7:	0.5 mg twice daily
Day 8 – end of treatment:	1 mg twice daily

Patients should be treated with CHANTIX for 12 weeks. For patients who have successfully stopped smoking at the end of 12 weeks, an additional course of 12 weeks treatment with CHANTIX is recommended to further increase the likelihood of long-term abstinence.

For patients who are sure that they are not able or willing to quit abruptly, consider a gradual approach to quitting smoking with CHANTIX. Patients should begin CHANTIX dosing and reduce smoking by 50% from baseline within the first four weeks, by an additional 50% in the next four weeks, and continue reducing with the goal of reaching complete abstinence by 12 weeks. Continue CHANTIX treatment for an additional 12 weeks, for a total of 24 weeks of treatment. Encourage patients to attempt quitting sooner if they feel ready [*see Clinical Studies (14.5)*].

Patients who are motivated to quit, and who did not succeed in stopping smoking during prior CHANTIX therapy for reasons other than intolerability due to adverse events or who relapsed after treatment, should be encouraged to make another attempt with CHANTIX once factors contributing to the failed attempt have been identified and addressed.

Consider a temporary or permanent dose reduction in patients who cannot tolerate the adverse effects of CHANTIX.

2.2 Dosage in Special Populations

Patients with Impaired Renal Function

No dosage adjustment is necessary for patients with mild to moderate renal impairment. For patients with severe renal impairment (estimated creatinine clearance less than 30 mL per min), the recommended starting dose of CHANTIX is 0.5 mg once daily. The dose may then be titrated as needed to a maximum dose of 0.5 mg twice daily. For patients with end-stage renal disease undergoing hemodialysis, a maximum dose of 0.5 mg once daily may be administered if tolerated [*see Use in Specific Populations (8.6), Clinical Pharmacology (12.3)*].

Elderly and Patients with Impaired Hepatic Function

No dosage adjustment is necessary for patients with hepatic impairment. Because elderly patients are more likely to have decreased renal function, care should be taken in dose selection, and it may be useful to monitor renal function [*see Use in Specific Populations (8.5)*].

3 DOSAGE FORMS AND STRENGTHS

Capsular, biconvex tablets: 0.5 mg (white to off-white, debossed with "Pfizer" on one side and "CHX 0.5" on the other side) and 1 mg (light blue, debossed with "Pfizer" on one side and "CHX 1.0" on the other side).

4 CONTRAINDICATIONS

CHANTIX is contraindicated in patients with a known history of serious hypersensitivity reactions or skin reactions to CHANTIX.

5 WARNINGS AND PRECAUTIONS

5.1 Neuropsychiatric Adverse Events including Suicidality

Serious neuropsychiatric adverse events have been reported in patients being treated with CHANTIX [*see Adverse Reactions (6.2)*]. These postmarketing reports have included changes in mood (including depression and mania), psychosis, hallucinations, paranoia, delusions, homicidal ideation, aggression, hostility, agitation, anxiety, and panic, as well as suicidal ideation, suicide attempt, and completed suicide. Some patients who stopped smoking may have been experiencing symptoms of nicotine withdrawal, including depressed mood. Depression, rarely including suicidal ideation, has been reported in smokers undergoing a smoking cessation attempt without medication. However, some of these adverse events occurred in patients taking CHANTIX who continued to smoke.

Neuropsychiatric adverse events occurred in patients without and with pre-existing psychiatric disease; some patients experienced worsening of their psychiatric illnesses. Some neuropsychiatric adverse events, including unusual and sometimes aggressive behavior directed to oneself or others, may have been worsened by concomitant use of alcohol [*see Warnings and Precautions (5.3), Adverse Reactions (6.2)*]. Observe patients for the occurrence of neuropsychiatric adverse events. Advise patients and caregivers that the patient should stop taking CHANTIX and contact a healthcare provider immediately if agitation, depressed mood, or changes in

behavior or thinking that are not typical for the patient are observed, or if the patient develops suicidal ideation or suicidal behavior. The healthcare provider should evaluate the severity of the symptoms and the extent to which the patient is benefiting from treatment, and consider options including dose reduction, continued treatment under closer monitoring, or discontinuing treatment. In many postmarketing cases, resolution of symptoms after discontinuation of CHANTIX was reported. However, the symptoms persisted in some cases; therefore, ongoing monitoring and supportive care should be provided until symptoms resolve.

The neuropsychiatric safety of CHANTIX was evaluated in a randomized, double-blind, active and placebo-controlled study that included patients without a history of psychiatric disorder (non-psychiatric cohort, N=3912) and patients with a history of psychiatric disorder (psychiatric cohort, N=4003). In the non-psychiatric cohort, CHANTIX was not associated with an increased incidence of clinically significant neuropsychiatric adverse events in a composite endpoint comprising anxiety, depression, feeling abnormal, hostility, agitation, aggression, delusions, hallucinations, homicidal ideation, mania, panic, and irritability. In the psychiatric cohort, there were more events reported in each treatment group compared to the non-psychiatric cohort, and the incidence of events in the composite endpoint was higher for each of the active treatments compared to placebo: Risk Differences (RDs) (95%CI) vs. placebo were 2.7% (-0.05, 5.4) for CHANTIX, 2.2% (-0.5, 4.9) for bupropion, and 0.4% (-2.2, 3.0) for transdermal nicotine. In the non-psychiatric cohort, neuropsychiatric adverse events of a serious nature were reported in 0.1% of CHANTIX-treated patients and 0.4% of placebo-treated patients. In the psychiatric cohort, neuropsychiatric events of a serious nature were reported in 0.6% of CHANTIX-treated patients, with 0.5% involving psychiatric hospitalization. In placebo-treated patients, serious neuropsychiatric events occurred in 0.6%, with 0.2% requiring psychiatric hospitalization [see *Clinical Studies (14.10)*].

5.2 Seizures

During clinical trials and the postmarketing experience, there have been reports of seizures in patients treated with CHANTIX. Some patients had no history of seizures, whereas others had a history of seizure disorder that was remote or well-controlled. In most cases, the seizure occurred within the first month of therapy. Weigh this potential risk against the potential benefits before prescribing CHANTIX in patients with a history of seizures or other factors that can lower the seizure threshold. Advise patients to discontinue CHANTIX and contact a healthcare provider immediately if they experience a seizure while on treatment [see *Adverse Reactions (6.2)*].

5.3 Interaction with Alcohol

There have been postmarketing reports of patients experiencing increased intoxicating effects of alcohol while taking CHANTIX. Some cases described unusual and sometimes aggressive behavior, and were often accompanied by amnesia for the events. Advise patients to reduce the amount of alcohol they consume while taking CHANTIX until they know whether CHANTIX affects their tolerance for alcohol [see *Adverse Reactions (6.2)*].

5.4 Accidental Injury

There have been postmarketing reports of traffic accidents, near-miss incidents in traffic, or other accidental injuries in patients taking CHANTIX. In some cases, the patients reported somnolence, dizziness, loss of consciousness or difficulty concentrating that resulted in impairment, or concern about potential impairment, in driving or operating machinery. Advise patients to use caution driving or operating machinery or engaging in other potentially hazardous activities until they know how CHANTIX may affect them.

5.5 Cardiovascular Events

A comprehensive evaluation of cardiovascular (CV) risk with CHANTIX suggests that patients with underlying CV disease may be at increased risk; however, these concerns must be balanced with the health benefits of smoking cessation. CV risk has been assessed for CHANTIX in randomized controlled trials (RCT) and meta-analyses of RCTs. In a smoking cessation trial in patients with stable CV disease, CV events were infrequent overall; however, nonfatal myocardial infarction (MI) and nonfatal stroke occurred more frequently in patients treated with CHANTIX compared to placebo. All-cause and CV mortality was lower in patients treated with CHANTIX [see *Clinical Studies (14.8)*]. This study was included in a meta-analysis of 15 CHANTIX efficacy trials in various clinical populations that showed an increased hazard ratio for Major Adverse Cardiovascular Events (MACE) of 1.95; however, the finding was not statistically significant (95% CI: 0.79, 4.82). In the large postmarketing neuropsychiatric safety outcome trial, an analysis of adjudicated MACE events was conducted for patients while in the trial and during a 28-week non-treatment extension period. Few MACE events occurred during the trial; therefore, the findings did not contribute substantively to the understanding of CV risk with CHANTIX. Instruct patients to notify their healthcare providers of new or worsening CV symptoms and to seek immediate medical attention if they experience signs and symptoms of MI or stroke [see *Clinical Studies (14.10)*].

5.6 Somnambulism

Cases of somnambulism have been reported in patients taking CHANTIX. Some cases described harmful behavior to self, others, or property. Instruct patients to discontinue CHANTIX and notify their healthcare provider if they experience somnambulism [see *Adverse Reactions (6.2)*].

5.7 Angioedema and Hypersensitivity Reactions

There have been postmarketing reports of hypersensitivity reactions including angioedema in patients treated with CHANTIX [see *Adverse Reactions (6.2)*, *Patient Counseling Information (17)*]. Clinical signs included swelling of the face, mouth (tongue, lips, and gums), extremities, and neck (throat and larynx). There were infrequent reports of life-threatening angioedema requiring emergent medical attention due to respiratory compromise. Instruct patients to discontinue CHANTIX and immediately seek medical care if they experience these symptoms.

5.8 Serious Skin Reactions

There have been postmarketing reports of rare but serious skin reactions, including Stevens-Johnson Syndrome and erythema multiforme, in patients using CHANTIX [see *Adverse Reactions (6.2)*]. As these skin reactions can be life-threatening, instruct patients to stop taking CHANTIX and contact a healthcare provider immediately at the first appearance of a skin rash with mucosal lesions or any other signs of hypersensitivity.

5.9 Nausea

Nausea was the most common adverse reaction reported with CHANTIX treatment. Nausea was generally described as mild or moderate and often transient; however, for some patients, it was persistent over several months. The incidence of nausea was dose-dependent. Initial dose-titration was beneficial in reducing the occurrence of nausea. For patients treated to the maximum recommended dose of 1 mg twice daily following initial dosage titration, the incidence of nausea was 30% compared with 10% in patients taking a comparable placebo regimen. In patients taking CHANTIX 0.5 mg twice daily following initial titration, the incidence was 16% compared with 11% for placebo. Approximately 3% of patients treated with CHANTIX 1 mg twice daily in studies involving 12 weeks of treatment discontinued treatment prematurely because of nausea. For patients with intolerable nausea, a dose reduction should be considered.

6 ADVERSE REACTIONS

The following serious adverse reactions were reported in postmarketing experience and are discussed in greater detail in other sections of the labeling:

- Neuropsychiatric Adverse Events including Suicidality [see Warnings and Precautions (5.1)]
- Seizures [see Warnings and Precautions (5.2)]
- Interaction with Alcohol [see Warnings and Precautions (5.3)]
- Accidental Injury [see Warnings and Precautions (5.4)]
- Cardiovascular Events [see Warnings and Precautions (5.5)]
- Somnambulism [see Warnings and Precautions (5.6)]
- Angioedema and Hypersensitivity Reactions [see Warnings and Precautions (5.7)]
- Serious Skin Reactions [see Warnings and Precautions (5.8)]

In the placebo-controlled premarketing studies, the most common adverse events associated with CHANTIX (>5% and twice the rate seen in placebo-treated patients) were nausea, abnormal (vivid, unusual, or strange) dreams, constipation, flatulence, and vomiting.

The treatment discontinuation rate due to adverse events in patients dosed with 1 mg twice daily was 12% for CHANTIX, compared to 10% for placebo in studies of three months' treatment. In this group, the discontinuation rates that are higher than placebo for the most common adverse events in CHANTIX-treated patients were as follows: nausea (3% vs. 0.5% for placebo), insomnia (1.2% vs. 1.1% for placebo), and abnormal dreams (0.3% vs. 0.2% for placebo).

Smoking cessation, with or without treatment, is associated with nicotine withdrawal symptoms and has also been associated with the exacerbation of underlying psychiatric illness.

6.1 Clinical Trials Experience

Because clinical trials are conducted under widely varying conditions, the adverse reactions rates observed in the clinical studies of a drug cannot be directly compared to rates in the clinical trials of another drug and may not reflect the rates observed in clinical practice.

During the premarketing development of CHANTIX, over 4500 subjects were exposed to CHANTIX, with over 450 treated for at least 24 weeks and approximately 100 for a year. Most study participants were treated for 12 weeks or less.

The most common adverse event associated with CHANTIX treatment is nausea, occurring in 30% of patients treated at the recommended dose, compared with 10% in patients taking a comparable placebo regimen [see Warnings and Precautions (5.9)].

Table 1 shows the adverse events for CHANTIX and placebo in the 12- week fixed dose premarketing studies with titration in the first week [Studies 2 (titrated arm only), 4, and 5]. Adverse events were categorized using the Medical Dictionary for Regulatory Activities (MedDRA, Version 7.1).

MedDRA High Level Group Terms (HLGT) reported in ≥5% of patients in the CHANTIX 1 mg twice daily dose group, and more commonly than in the placebo group, are listed, along with subordinate Preferred Terms (PT) reported in ≥1% of CHANTIX patients (and at least 0.5% more frequent than placebo). Closely related Preferred Terms such as 'Insomnia', 'Initial insomnia', 'Middle insomnia', 'Early morning awakening' were grouped, but individual patients reporting two or more grouped events are only counted once.

Table 1. Common Treatment Emergent AEs (%) in the Fixed-Dose, Placebo-Controlled Studies (HLGTs ≥5% of Patients in the 1 mg BID CHANTIX Group and More Commonly than Placebo and PT ≥1% in the 1 mg BID CHANTIX Group, and 1 mg BID CHANTIX at Least 0.5% More than Placebo)

SYSTEM ORGAN CLASS High Level Group Term Preferred Term	CHANTIX 0.5 mg BID N=129	CHANTIX 1 mg BID N=821	Placebo N=805
GASTROINTESTINAL (GI)			
GI Signs and Symptoms			
Nausea	16	30	10
Abdominal Pain *	5	7	5
Flatulence	9	6	3
Dyspepsia	5	5	3
Vomiting	1	5	2
GI Motility/Defecation Conditions			
Constipation	5	8	3
Gastroesophageal reflux disease	1	1	0
Salivary Gland Conditions			
Dry mouth	4	6	4
PSYCHIATRIC DISORDERS			
Sleep Disorder/Disturbances			
Insomnia **	19	18	13
Abnormal dreams	9	13	5
Sleep disorder	2	5	3
Nightmare	2	1	0
NERVOUS SYSTEM			
Headaches			
Headache	19	15	13
Neurological Disorders			

NEC			
Dysgeusia	8	5	4
Somnolence	3	3	2
Lethargy	2	1	0
GENERAL DISORDERS			
General Disorders NEC			
Fatigue/Malaise/Asthenia	4	7	6
RESPIR/THORACIC/MEDIAST			
Respiratory Disorders NEC			
Rhinorrhea	0	1	0
Dyspnea	2	1	1
Upper Respiratory Tract Disorder	7	5	4
SKIN/SUBCUTANEOUS TISSUE			
Epidermal and Dermal Conditions			
Rash	1	3	2
Pruritis	0	1	1
METABOLISM and NUTRITION			
Appetite/General Nutrition Disorders			
Increased appetite	4	3	2
Decreased appetite/ Anorexia	1	2	1

* Includes PTs Abdominal (pain, pain upper, pain lower, discomfort, tenderness, distension) and Stomach discomfort

** Includes PTs Insomnia/Initial insomnia/Middle insomnia/Early morning awakening

The overall pattern and frequency of adverse events during the longer-term premarketing trials was similar to those described in Table 1, though several of the most common events were reported by a greater proportion of patients with long-term use (e.g., nausea was reported in 40% of patients treated with CHANTIX 1 mg twice daily in a one year study, compared to 8% of placebo-treated patients).

Following is a list of treatment-emergent adverse events reported by patients treated with CHANTIX during all premarketing clinical trials and updated based on pooled data from 18 placebo-controlled pre- and postmarketing studies, including approximately 5,000 patients treated with varenicline. Adverse events were categorized using MedDRA, Version 16.0. The listing does not include those events already listed in the previous tables or elsewhere in labeling, those events for which a drug cause was remote, those events which were so general as to be uninformative, and those events reported only once which did not have a substantial probability of being acutely life-threatening.

Blood and Lymphatic System Disorders. *Infrequent:* anemia, lymphadenopathy. *Rare:* leukocytosis, splenomegaly, thrombocytopenia.

Cardiac Disorders. *Infrequent:* angina pectoris, myocardial infarction, palpitations, tachycardia. *Rare:* acute coronary syndrome, arrhythmia, atrial fibrillation, bradycardia, cardiac flutter, cor pulmonale, coronary artery disease, ventricular extrasystoles.

Ear and Labyrinth Disorders. *Infrequent:* tinnitus, vertigo. *Rare:* deafness, Meniere's disease.

Endocrine Disorders. *Infrequent:* thyroid gland disorders.

Eye Disorders. *Infrequent:* conjunctivitis, eye irritation, eye pain, vision blurred, visual impairment. *Rare:* blindness transient, cataract subcapsular, dry eye, night blindness, ocular vascular disorder, photophobia, vitreous floaters.

Gastrointestinal Disorders. *Frequent:* diarrhea, toothache. *Infrequent:* dysphagia, eructation, gastritis, gastrointestinal hemorrhage, mouth ulceration. *Rare:* enterocolitis, esophagitis, gastric ulcer, intestinal obstruction, pancreatitis acute.

General Disorders and Administration Site Conditions. *Frequent:* chest pain. *Infrequent:* chest discomfort, chills, edema, influenza-like illness, pyrexia.

Hepatobiliary Disorders. *Rare:* gall bladder disorder.

Investigations. *Frequent:* liver function test abnormal, weight increased. *Infrequent:* electrocardiogram abnormal. *Rare:* muscle enzyme increased, urine analysis abnormal.

Metabolism and Nutrition Disorders. *Infrequent:* diabetes mellitus, hypoglycemia. *Rare:* hyperlipidemia, hypokalemia.

Musculoskeletal and Connective Tissue Disorders. *Frequent:* arthralgia, back pain, myalgia. *Infrequent:* arthritis, muscle cramp, musculoskeletal pain. *Rare:* myositis, osteoporosis.

Nervous System Disorders. *Frequent:* disturbance in attention, dizziness. *Infrequent:* amnesia, convulsion, migraine, parosmia, syncope, tremor. *Rare:* balance disorder, cerebrovascular accident, dysarthria, mental impairment, multiple sclerosis, VIIth nerve paralysis, nystagmus, psychomotor hyperactivity, psychomotor skills impaired, restless legs syndrome, sensory disturbance, transient ischemic attack, visual field defect.

Psychiatric Disorders. *Infrequent:* dissociation, libido decreased, mood swings, thinking abnormal. *Rare:* bradyphrenia, disorientation, euphoric mood.

Renal and Urinary Disorders. *Infrequent:* nocturia, pollakiuria, urine abnormality. *Rare:* nephrolithiasis, polyuria, renal failure acute, urethral syndrome, urinary retention.

Reproductive System and Breast Disorders. *Frequent:* menstrual disorder. *Infrequent:* erectile dysfunction. *Rare:* sexual dysfunction.

Respiratory, Thoracic and Mediastinal Disorders. *Frequent:* respiratory disorders. *Infrequent:* asthma, epistaxis, rhinitis allergic, upper respiratory tract inflammation. *Rare:* pleurisy, pulmonary embolism.

Skin and Subcutaneous Tissue Disorders. *Infrequent:* acne, dry skin, eczema, erythema, hyperhidrosis, urticaria. *Rare:* photosensitivity reaction, psoriasis.

Vascular Disorders. *Infrequent:* hot flush. *Rare:* thrombosis.

CHANTIX has also been studied in postmarketing trials including (1) a trial conducted in patients with chronic obstructive pulmonary disease (COPD), (2) a trial conducted in generally healthy patients (similar to those in the premarketing studies) in which they were allowed to select a quit date between days 8 and 35 of treatment ("alternative quit date instruction trial"), (3) a trial conducted in patients who did not succeed in stopping smoking during prior CHANTIX therapy, or who relapsed after treatment ("re-treatment trial"), (4) a trial conducted in patients with stable cardiovascular disease, (5) a trial conducted in patients with stable schizophrenia or schizoaffective disorder, (6) a trial conducted in patients with major depressive disorder, (7) a postmarketing neuropsychiatric safety outcome trial in patients without or with a history of psychiatric disorder, (8) a non-treatment extension of the postmarketing neuropsychiatric safety outcome trial that assessed CV safety, (9) a trial in patients who were not able or willing to quit abruptly and who were instructed to quit gradually ("gradual approach to quitting smoking trial").

Adverse events in the trial of patients with COPD (1), in the alternative quit date instruction trial (2), and in the gradual approach to quitting smoking trial (9) were similar to those observed in premarketing studies. In the re-treatment trial (3), the profile of common adverse events was similar to that previously reported, but, in addition, varenicline-treated patients also commonly reported diarrhea (6% vs. 4% in placebo-treated patients), depressed mood disorders and disturbances (6% vs. 1%), and other mood disorders and disturbances (5% vs. 2%).

In the trial of patients with stable cardiovascular disease (4), more types and a greater number of cardiovascular events were reported compared to premarketing studies, as shown in Table 1 and in Table 2 below.

Table 2. Cardiovascular Mortality and Nonfatal Cardiovascular Events (%) with a Frequency >1% in Either Treatment Group in the Trial of Patients with Stable Cardiovascular Disease

	CHANTIX 1 mg BID N=353	Placebo N=350
Adverse Events ≥1% in either treatment group		
<i>Up to 30 days after treatment</i>		
Angina pectoris	3.7	2.0
Chest pain	2.5	2.3
Peripheral edema	2.0	1.1
Hypertension	1.4	2.6
Palpitations	0.6	1.1
Adjudicated Cardiovascular Mortality (up to 52 weeks)	0.3	0.6
Adjudicated Nonfatal Serious Cardiovascular Events ≥1% in either treatment group		
<i>Up to 30 days after treatment</i>		
Nonfatal MI	1.1	0.3
Hospitalization for angina pectoris	0.6	1.1
<i>Beyond 30 days after treatment and up to 52 weeks</i>		
Need for coronary revascularization*	2.0	0.6
Hospitalization for angina pectoris	1.7	1.1
New diagnosis of peripheral vascular disease (PVD) or admission for a PVD procedure	1.4	0.6

*some procedures were part of management of nonfatal MI and hospitalization for angina

In the trial of patients with stable schizophrenia or schizoaffective disorder (5), 128 smokers on antipsychotic medication were randomized 2:1 to varenicline (1 mg twice daily) or placebo for 12 weeks with 12-week non-drug follow-up. The most common treatment emergent adverse events reported in this trial are shown in Table 3 below.

Table 3. Common Treatment Emergent AEs (%) in the Trial of Patients with Stable Schizophrenia or Schizoaffective Disorder

	CHANTIX 1 mg BID N=84	Placebo N=43
Adverse Events ≥10% in the varenicline group		
Nausea	24	14
Headache	11	19
Vomiting	11	9
Psychiatric Adverse Events ≥5% and at a higher rate than in the placebo group		
Insomnia	10	5

For the trial of patients with major depressive disorder (6), the most common treatment emergent adverse events reported are shown in Table 4 below. Additionally, in this trial, patients treated with varenicline were more likely than patients treated with placebo to report one of events related to hostility and aggression (3% vs. 1%).

Table 4. Common Treatment Emergent AEs (%) in the Trial of Patients with Major Depressive Disorder

	CHANTIX 1 mg BID N=256	Placebo N=269
Adverse Events ≥10% in either treatment group		
Nausea	27	10
Headache	17	11
Abnormal dreams	11	8
Insomnia	11	5
Irritability	11	8
Psychiatric Adverse Events ≥2% in any treatment group and not included above		
Depressed mood disorders and disturbances	11	9
Anxiety	7	9
Agitation	7	4
Tension	4	3
Hostility	2	0.4
Restlessness	2	2

In the trial of patients without or with a history of psychiatric disorder (7), the most common adverse events in subjects treated with varenicline were similar to those observed in premarketing studies. Most common treatment-emergent adverse events reported in this trial are shown in Table 5 below.

Table 5. Treatment Emergent Common AEs (%) in the Trial of Patients without or with a History of Psychiatric Disorder

	CHANTIX 1 mg BID	Placebo
Adverse Events ≥10% in the varenicline group		
Entire study population, N	1982	1979
Nausea	25	7
Headache	12	10
Psychiatric Adverse Events ≥2% in any treatment group		
Non-psychiatric cohort, N	975	982
Abnormal dreams	8	4
Agitation	3	3
Anxiety	5	6
Depressed mood	3	3
Insomnia	10	7
Irritability	3	4
Sleep disorder	3	2
Psychiatric cohort, N	1007	997
Abnormal dreams	12	5
Agitation	5	4
Anxiety	8	6
Depressed mood	5	5
Depression	5	5
Insomnia	9	7
Irritability	5	7
Nervousness	2	3
Sleep disorder	3	2

In the non-treatment extension of the postmarketing neuropsychiatric safety outcomes trial that assessed CV safety (8), the most common adverse events in subjects treated with varenicline and occurring up to 30 days after last dose of treatment were similar to those observed in premarketing studies.

6.2 Postmarketing Experience

The following adverse events have been reported during post-approval use of CHANTIX. Because these events are reported voluntarily from a population of uncertain size, it is not possible to reliably estimate their frequency or establish a causal relationship to drug exposure.

There have been reports of depression, mania, psychosis, hallucinations, paranoia, delusions, homicidal ideation, aggression, hostility, anxiety, and panic, as well as suicidal ideation, suicide attempt, and completed suicide in patients attempting to quit smoking while taking CHANTIX [see *Warnings and Precautions (5.1)*].

There have been postmarketing reports of new or worsening seizures in patients treated with CHANTIX [see *Warnings and Precautions (5.2)*].

There have been postmarketing reports of patients experiencing increased intoxicating effects of alcohol while taking CHANTIX. Some reported neuropsychiatric events, including unusual and sometimes aggressive behavior [see *Warnings and Precautions (5.1) and (5.3)*].

There have been reports of hypersensitivity reactions, including angioedema [see *Warnings and Precautions (5.7)*].

There have also been reports of serious skin reactions, including Stevens-Johnson Syndrome and erythema multiforme, in patients taking CHANTIX [see *Warnings and Precautions (5.8)*].

There have been reports of myocardial infarction (MI) and cerebrovascular accident (CVA) including ischemic and hemorrhagic events in patients taking CHANTIX. In the majority of the reported cases, patients had pre-existing cardiovascular disease and/or other risk factors. Although smoking is a risk factor for MI and CVA, based on temporal relationship between medication use and events, a contributory role of varenicline cannot be ruled out [see *Warnings and Precautions (5.5)*].

There have been reports of hyperglycemia in patients following initiation of CHANTIX.

There have been reports of somnambulism, some resulting in harmful behavior to self, others, or property in patients treated with CHANTIX [see *Warnings and Precautions (5.6)*].

7 DRUG INTERACTIONS

Based on varenicline characteristics and clinical experience to date, CHANTIX has no clinically meaningful pharmacokinetic drug interactions [see *Clinical Pharmacology (12.3)*].

7.1 Use with Other Drugs for Smoking Cessation

Safety and efficacy of CHANTIX in combination with other smoking cessation therapies have not been studied.

Bupropion

Varenicline (1 mg twice daily) did not alter the steady-state pharmacokinetics of bupropion (150 mg twice daily) in 46 smokers. The safety of the combination of bupropion and varenicline has not been established.

Nicotine replacement therapy (NRT)

Although co-administration of varenicline (1 mg twice daily) and transdermal nicotine (21 mg/day) for up to 12 days did not affect nicotine pharmacokinetics, the incidence of nausea, headache, vomiting, dizziness, dyspepsia, and fatigue was greater for the combination than for NRT alone. In this study, eight of twenty-two (36%) patients treated with the combination of varenicline and NRT prematurely discontinued treatment due to adverse events, compared to 1 of 17 (6%) of patients treated with NRT and placebo.

7.2 Effect of Smoking Cessation on Other Drugs

Physiological changes resulting from smoking cessation, with or without treatment with CHANTIX, may alter the pharmacokinetics or pharmacodynamics of certain drugs (e.g., theophylline, warfarin, insulin) for which dosage adjustment may be necessary.

8 USE IN SPECIFIC POPULATIONS

8.1 Pregnancy

Risk Summary

Available data have not suggested an increased risk for major birth defects following exposure to varenicline in pregnancy, compared with women who smoke [see Data]. Smoking during pregnancy is associated with maternal, fetal, and neonatal risks (see Clinical Considerations). In animal studies, varenicline did not result in major malformations but caused decreased fetal weights in rabbits when dosed during organogenesis at exposures equivalent to 50 times the exposure at the maximum recommended human dose (MRHD). Additionally, administration of varenicline to pregnant rats during organogenesis through lactation produced developmental toxicity in offspring at maternal exposures equivalent to 36 times human exposure at the MRHD [see Data].

The estimated background risk of oral clefts is increased by approximately 30% in infants of women who smoke during pregnancy, compared to pregnant women who do not smoke. The background risk of other major birth defects and miscarriage for the indicated population are unknown. In the US general population, the estimated background risk of major birth defects and miscarriage in clinically recognized pregnancies is 2-4% and 15-20%, respectively.

Clinical Considerations

Disease-Associated Maternal and/or Embryo/Fetal Risk

Smoking during pregnancy causes increased risks of orofacial clefts, premature rupture of membranes, placenta previa, placental abruption, ectopic pregnancy, fetal growth restriction and low birth weight, stillbirth, preterm delivery and shortened gestation, neonatal death, sudden infant death syndrome and reduction of lung function in infants. It is not known whether quitting smoking with CHANTIX during pregnancy reduces these risks.

Data

Human Data

A population-based observational cohort study using the national registers of Denmark and Sweden compared pregnancy and birth outcomes among women exposed to varenicline (N=335, includes 317 first trimester exposed) with women who smoked during pregnancy (N=78,412) and with non-smoking pregnant women (N=806,438). The prevalence of major malformations, the primary outcome, was similar in all groups, including between smoking and non-smoking groups. The prevalence of adverse perinatal outcomes in the varenicline-exposed cohort was not greater than in the cohort of women who smoked, and differed somewhat between the three cohorts. The prevalences of the primary and secondary outcomes are shown in Table 6.

Table 6. Summary of Primary and Secondary Outcomes for Three Birth Cohorts

Outcome	Varenicline Cohort (n=335)	Smoking Cohort (n=78,412)	Non-Smoking Cohort (n=806,438)
Major congenital malformation*	12 / 334 (3.6%)	3,382 / 78,028 (4.3%)	33,950 / 804,020 (4.2%)
Stillbirth	1 (0.3%)	384 (0.5%)	2,418 (0.3%)
Small for gestational age	42 (12.5%)	13,433 (17.1%)	73,135 (9.1%)
Preterm birth	25 (7.5%)	6,173 (7.9%)	46,732 (5.8%)
Premature rupture of membranes	12 (3.6%)	4,246 (5.4%)	30,641 (3.8%)
Sudden infant death syndrome**	0/307 (0.0%)	51/71,720 (0.1%)	58/755,939 (<0.1%)

*Included only live births in the cohorts. Prevalence among first trimester varenicline-exposed pregnancies (11/317 [3.5%]).

**There was a lag in death data in Denmark, so the cohorts were smaller.

The study limitations include the inability to capture malformations in pregnancies that do not result in a live birth, and possible misclassification of outcome and of exposure to varenicline or to smoking.

Other small epidemiological studies of pregnant women exposed to varenicline did not identify an association with major malformations, consistent with the Danish and Swedish observational cohort study. Methodological limitations of these studies include small samples and lack of adequate controls.

Overall, available studies cannot definitely establish or exclude any varenicline-associated risk during pregnancy.

Animal Data

Pregnant rats and rabbits received varenicline succinate during organogenesis at oral doses up to 15 and 30 mg/kg/day, respectively. While no fetal structural abnormalities occurred in either species, maternal toxicity, characterized by reduced body weight gain, and reduced fetal weights occurred in rabbits at the highest dose (exposures 50 times the human exposure at the MRHD of 1 mg twice daily based on AUC). Fetal weight reduction did not occur in rabbits at exposures 23 times the human exposure at the MRHD based on AUC.

In a pre- and postnatal development study, pregnant rats received up to 15 mg/kg/day of oral varenicline succinate from organogenesis through lactation. Maternal toxicity, characterized by a decrease in body weight gain was observed at 15 mg/kg/day (36 times the human exposure at the MRHD based on AUC). However, decreased fertility and increased auditory startle response occurred in offspring at the highest maternal dose of 15 mg/kg/day.

8.2 Lactation

Risk Summary

There are no data on the presence of varenicline in human milk, the effects on the breastfed infant, or the effects on milk production. In animal studies varenicline was present in milk of lactating rats [see Data]. However, due to species-specific differences in lactation physiology, animal data may not reliably predict drug levels in human milk. The lack of clinical data during lactation precludes a clear determination of the risk of CHANTIX to an infant during lactation; however the developmental and health benefits of breastfeeding should be considered along with the mother's clinical need for CHANTIX and any potential adverse effects on the breastfed child from CHANTIX or from the underlying maternal condition.

Clinical Considerations

Because there are no data on the presence of varenicline in human milk and the effects on the breastfed infant, breastfeeding women should monitor their infant for seizures and excessive vomiting, which are adverse reactions that have occurred in adults that may be clinically relevant in breastfeeding infants.

Data

In a pre- and postnatal development study, pregnant rats received up to 15 mg/kg/day of oral varenicline succinate through gestation and lactation. Mean serum concentrations of varenicline in the nursing pups were 5-22% of maternal serum concentrations.

8.4 Pediatric Use

CHANTIX is not recommended for use in pediatric patients 16 years of age or younger because its efficacy in this population was not demonstrated.

Single and multiple-dose pharmacokinetics of varenicline have been investigated in pediatric patients aged 12 to 17 years old (inclusive) and were approximately dose-proportional over the 0.5 mg to 2 mg daily dose range studied. Steady-state systemic exposure in adolescent patients of bodyweight >55 kg, as assessed by AUC (0-24), was comparable to that noted for the same doses in the adult population. When 0.5 mg BID was given, steady-state daily exposure of varenicline was, on average, higher (by approximately 40%) in adolescent patients with bodyweight ≤ 55 kg compared to that noted in the adult population.

The efficacy and safety of varenicline was evaluated in a randomized, double-blind, placebo-controlled study of 312 patients aged 12 to 19 years, who smoked an average of at least 5 cigarettes per day during the 30 days prior to recruitment, had a score of at least 4 on the Fagerstrom Test for Nicotine Dependence scale, and at least one previous failed quit attempt. Patients were stratified by age (12 to 16 years of age, n = 216 and 17 to 19 years of age, n = 96) and by body weight (≤55 kg and >55 kg). Patients were randomized to one of two doses of varenicline, adjusted by weight to provide plasma levels in the efficacious range (based on adult studies) and placebo. Patients received treatment for 12 weeks, followed by a non-treatment period of 40 weeks, along with age-appropriate counseling throughout the study. Results from this study showed that varenicline, at either dose studied, did not improve continuous abstinence rates at weeks 9 through 12 of treatment compared with placebo in subjects 12 to 19 years of age. The varenicline safety profile in this study was consistent with that observed in adult studies.

8.5 Geriatric Use

A combined single- and multiple-dose pharmacokinetic study demonstrated that the pharmacokinetics of 1 mg varenicline given once daily or twice daily to 16 healthy elderly male and female smokers (aged 65-75 years) for 7 consecutive days was similar to that of younger subjects. No overall differences in safety or effectiveness were observed between these subjects and younger subjects, and other reported clinical experience has not identified differences in responses between the elderly and younger patients, but greater sensitivity of some older individuals cannot be ruled out.

Varenicline is known to be substantially excreted by the kidney, and the risk of toxic reactions to this drug may be greater in patients with impaired renal function. Because elderly patients are more likely to have decreased renal function, care should be taken in dose selection, and it may be useful to monitor renal function [see *Dosage and Administration* (2.2)].

No dosage adjustment is recommended for elderly patients.

8.6 Renal Impairment

Varenicline is substantially eliminated by renal glomerular filtration along with active tubular secretion. Dose reduction is not required in patients with mild to moderate renal impairment. For patients with severe renal impairment (estimated creatinine clearance <30 mL/min), and for patients with end-stage renal disease undergoing hemodialysis, dosage adjustment is needed [see *Dosage and Administration* (2.2), *Clinical Pharmacology* (12.3)].

9 DRUG ABUSE AND DEPENDENCE

9.1 Controlled Substance

Varenicline is not a controlled substance.

9.3 Dependence

Humans

Fewer than 1 out of 1,000 patients reported euphoria in clinical trials with CHANTIX. At higher doses (greater than 2 mg), CHANTIX produced more frequent reports of gastrointestinal disturbances such as nausea and vomiting. There is no evidence of dose-escalation to maintain therapeutic effects in clinical studies, which suggests that tolerance does not develop. Abrupt discontinuation of CHANTIX was associated with an increase in irritability and sleep disturbances in up to 3% of patients. This suggests that, in some patients, varenicline may produce mild physical dependence which is not associated with addiction.

In a human laboratory abuse liability study, a single oral dose of 1 mg varenicline did not produce any significant positive or negative subjective responses in smokers. In non-smokers, 1 mg varenicline produced an increase in some positive subjective effects, but this was accompanied by an increase in negative adverse effects, especially nausea. A single oral dose of 3 mg varenicline uniformly produced unpleasant subjective responses in both smokers and non-smokers.

Animals

Studies in rodents have shown that varenicline produces behavioral responses similar to those produced by nicotine. In rats trained to discriminate nicotine from saline, varenicline produced full generalization to the nicotine cue. In self-administration studies, the degree to which varenicline substitutes for nicotine is dependent upon the requirement of the task. Rats trained to self-administer nicotine under easy conditions continued to self-administer varenicline to a degree comparable to that of nicotine; however in a more demanding task, rats self-administered varenicline to a lesser extent than nicotine. Varenicline pretreatment also reduced nicotine self-administration.

10 OVERDOSAGE

In case of overdose, standard supportive measures should be instituted as required.

Varenicline has been shown to be dialyzed in patients with end-stage renal disease [see *Clinical Pharmacology (12.3)*], however, there is no experience in dialysis following overdose.

11 DESCRIPTION

CHANTIX tablets contain varenicline (as the tartrate salt), which is a partial nicotinic agonist selective for $\alpha_4\beta_2$ nicotinic acetylcholine receptor subtypes.

Varenicline, as the tartrate salt, is a powder which is a white to off-white to slightly yellow solid with the following chemical name: 7,8,9,10-tetrahydro-6,10-methano-6H-pyrazino[2,3-h][3]benzazepine, (2*R*,3*R*)-2,3-dihydroxybutanedioate (1:1). It is highly soluble in water. Varenicline tartrate has a molecular weight of 361.35 Daltons, and a molecular formula of $C_{13}H_{13}N_3 \cdot C_4H_6O_6$. The chemical structure is:

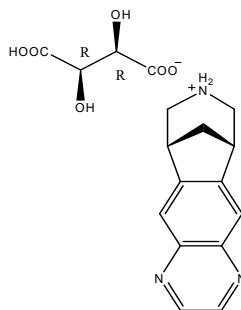

CHANTIX is supplied for oral administration in two strengths: a 0.5 mg capsular biconvex, white to off-white, film-coated tablet debossed with "Pfizer" on one side and "CHX 0.5" on the other side and a 1 mg capsular biconvex, light blue film-coated tablet debossed with "Pfizer" on one side and "CHX 1.0" on the other side. Each 0.5 mg CHANTIX tablet contains 0.85 mg of varenicline tartrate equivalent to 0.5 mg of varenicline free base; each 1 mg CHANTIX tablet contains 1.71 mg of varenicline tartrate equivalent to 1 mg of varenicline free base. The following inactive ingredients are included in the tablets: microcrystalline cellulose, anhydrous dibasic calcium phosphate, croscarmellose sodium, colloidal silicon dioxide, magnesium stearate, Opadry® White (for 0.5 mg), Opadry® Blue (for 1 mg), and Opadry® Clear.

12 CLINICAL PHARMACOLOGY

12.1 Mechanism of Action

Varenicline binds with high affinity and selectivity at $\alpha_4\beta_2$ neuronal nicotinic acetylcholine receptors. The efficacy of CHANTIX in smoking cessation is believed to be the result of varenicline's activity at $\alpha_4\beta_2$ sub-type of the nicotinic receptor where its binding produces agonist activity, while simultaneously preventing nicotine binding to these receptors.

Electrophysiology studies *in vitro* and neurochemical studies *in vivo* have shown that varenicline binds to $\alpha_4\beta_2$ neuronal nicotinic acetylcholine receptors and stimulates receptor-mediated activity, but at a significantly lower level than nicotine. Varenicline blocks the ability of nicotine to activate $\alpha_4\beta_2$ receptors and thus to stimulate the central nervous mesolimbic dopamine system, believed to be the neuronal mechanism underlying reinforcement and reward experienced upon smoking. Varenicline is highly selective and binds more potently to $\alpha_4\beta_2$ receptors than to other common nicotinic receptors (>500-fold $\alpha_3\beta_4$, >3,500-fold α_7 , >20,000-fold $\alpha_1\beta\gamma\delta$), or to non-nicotinic receptors and transporters (>2,000-fold). Varenicline also binds with moderate affinity ($K_i = 350$ nM) to the 5-HT₃ receptor.

12.3 Pharmacokinetics

Absorption

Maximum plasma concentrations of varenicline occur typically within 3-4 hours after oral administration. Following administration of multiple oral doses of varenicline, steady-state conditions were reached within 4 days. Over the recommended dosing range, varenicline exhibits linear pharmacokinetics after single or repeated doses.

In a mass balance study, absorption of varenicline was virtually complete after oral administration and systemic availability was ~90%.

Food Effect

Oral bioavailability of varenicline is unaffected by food or time-of-day dosing.

Distribution

Plasma protein binding of varenicline is low ($\leq 20\%$) and independent of both age and renal function.

Elimination

The elimination half-life of varenicline is approximately 24 hours.

Metabolism

Varenicline undergoes minimal metabolism, with 92% excreted unchanged in the urine.

Excretion

Renal elimination of varenicline is primarily through glomerular filtration along with active tubular secretion possibly via the organic cation transporter, OCT2.

Specific Populations

There are no clinically meaningful differences in varenicline pharmacokinetics due to age, race, gender, smoking status, or use of concomitant medications, as demonstrated in specific pharmacokinetic studies and in population pharmacokinetic analyses.

Age: Geriatric Patients

A combined single- and multiple-dose pharmacokinetic study demonstrated that the pharmacokinetics of 1 mg varenicline given once daily or twice daily to 16 healthy elderly male and female smokers (aged 65-75 years) for 7 consecutive days was similar to that of younger subjects.

Age: Pediatric Patients

CHANTIX is not recommended for use in pediatric patients 16 years of age or younger because its efficacy in this population was not demonstrated [see *Use in Specific Populations* (8.4)].

Renal Impairment

Varenicline pharmacokinetics were unchanged in subjects with mild renal impairment (estimated creatinine clearance >50 mL/min and ≤80 mL/min). In subjects with moderate renal impairment (estimated creatinine clearance ≥30 mL/min and ≤50 mL/min), varenicline exposure increased 1.5-fold compared with subjects with normal renal function (estimated creatinine clearance >80 mL/min). In subjects with severe renal impairment (estimated creatinine clearance <30 mL/min), varenicline exposure was increased 2.1-fold. In subjects with end-stage-renal disease (ESRD) undergoing a three-hour session of hemodialysis for three days a week, varenicline exposure was increased 2.7-fold following 0.5 mg once daily administration for 12 days. The plasma C_{max} and AUC of varenicline noted in this setting were similar to those of healthy subjects receiving 1 mg twice daily [see *Dosage and Administration* (2.2), *Use in Specific Populations* (8.6)]. Additionally, in subjects with ESRD, varenicline was efficiently removed by hemodialysis [see *Overdosage* (10)].

Hepatic Impairment

Due to the absence of significant hepatic metabolism, varenicline pharmacokinetics should be unaffected in patients with hepatic impairment.

Drug-Drug Interactions

In vitro studies demonstrated that varenicline does not inhibit the following cytochrome P450 enzymes (IC₅₀ >6400 ng/mL): 1A2, 2A6, 2B6, 2C8, 2C9, 2C19, 2D6, 2E1, and 3A4/5. Also, in human hepatocytes *in vitro*, varenicline does not induce the cytochrome P450 enzymes 1A2 and 3A4.

In vitro studies demonstrated that varenicline does not inhibit human renal transport proteins at therapeutic concentrations. Therefore, drugs that are cleared by renal secretion (e.g., metformin [see *below*]) are unlikely to be affected by varenicline.

In vitro studies demonstrated the active renal secretion of varenicline is mediated by the human organic cation transporter OCT2. Co-administration with inhibitors of OCT2 (e.g., cimetidine [see *below*]) may not necessitate a dose adjustment of CHANTIX as the increase in systemic exposure to CHANTIX is not expected to be clinically meaningful. Furthermore, since metabolism of varenicline represents less than 10% of its clearance, drugs known to affect the cytochrome P450 system are unlikely to alter the pharmacokinetics of CHANTIX [see *Clinical Pharmacology* (12.3)]; therefore, a dose adjustment of CHANTIX would not be required.

Drug interaction studies were performed with varenicline and digoxin, warfarin, transdermal nicotine, bupropion, cimetidine, and metformin. No clinically meaningful pharmacokinetic drug-drug interactions have been identified.

Metformin

When co-administered to 30 smokers, varenicline (1 mg twice daily) did not alter the steady-state pharmacokinetics of metformin (500 mg twice daily), which is a substrate of OCT2. Metformin had no effect on varenicline steady-state pharmacokinetics.

Cimetidine

Co-administration of an OCT2 inhibitor, cimetidine (300 mg four times daily), with varenicline (2 mg single dose) to 12 smokers increased the systemic exposure of varenicline by 29% (90% CI: 21.5%, 36.9%) due to a reduction in varenicline renal clearance.

Digoxin

Varenicline (1 mg twice daily) did not alter the steady-state pharmacokinetics of digoxin administered as a 0.25 mg daily dose in 18 smokers.

Warfarin

Varenicline (1 mg twice daily) did not alter the pharmacokinetics of a single 25 mg dose of (R, S)-warfarin in 24 smokers. Prothrombin time (INR) was not affected by varenicline. Smoking cessation itself may result in changes to warfarin pharmacokinetics [see *Drug Interactions* (7.2)].

Use with Other Drugs for Smoking Cessation

Bupropion: Varenicline (1 mg twice daily) did not alter the steady-state pharmacokinetics of bupropion (150 mg twice daily) in 46 smokers [see *Drug Interactions* (7.1)].

NRT: Although co-administration of varenicline (1 mg twice daily) and transdermal nicotine (21 mg/day) for up to 12 days did not affect nicotine pharmacokinetics, the incidence of adverse reactions was greater for the combination than for NRT alone [see *Drug Interactions* (7.1)].

13 NONCLINICAL TOXICOLOGY

13.1 Carcinogenesis, Mutagenesis, Impairment of Fertility

Carcinogenesis

Lifetime carcinogenicity studies were performed in CD-1 mice and Sprague-Dawley rats. There was no evidence of a carcinogenic effect in mice administered varenicline by oral gavage for 2 years at doses up to 20 mg/kg/day (47 times the maximum recommended human daily (MRHD) exposure based on AUC). Rats were administered varenicline (1, 5, and 15 mg/kg/day) by oral gavage for 2 years. In male rats (n = 65 per sex per dose group), incidences of hibernoma (tumor of the brown fat) were increased at the mid dose (1 tumor, 5 mg/kg/day, 23 times the MRHD exposure based on AUC) and maximum dose (2 tumors, 15 mg/kg/day, 67 times the MRHD exposure based on AUC). The clinical relevance of this finding to humans has not been established. There was no evidence of carcinogenicity in female rats.

Mutagenesis

Varenicline was not genotoxic, with or without metabolic activation, in the following assays: Ames bacterial mutation assay; mammalian CHO/HGPRT assay; and tests for cytogenetic aberrations *in vivo* in rat bone marrow and *in vitro* in human lymphocytes.

Impairment of Fertility

There was no evidence of impairment of fertility in either male or female Sprague-Dawley rats administered varenicline succinate up to 15 mg/kg/day (67 and 36 times, respectively, the MRHD exposure based on AUC at 1 mg twice daily). Maternal toxicity, characterized by a decrease in body weight gain, was observed at 15 mg/kg/day. However, a decrease in fertility was noted in the offspring of pregnant rats who were administered varenicline succinate at an oral dose of 15 mg/kg/day. This decrease in fertility in the offspring of treated female rats was not evident at an oral dose of 3 mg/kg/day (9 times the MRHD exposure based on AUC at 1 mg twice daily).

14 CLINICAL STUDIES

The efficacy of CHANTIX in smoking cessation was demonstrated in six clinical trials in which a total of 3659 chronic cigarette smokers (≥ 10 cigarettes per day) were treated with CHANTIX. In all clinical studies, abstinence from smoking was determined by patient self-report and verified by measurement of exhaled carbon monoxide ($CO \leq 10$ ppm) at weekly visits. Among the CHANTIX-treated patients enrolled in these studies, the completion rate was 65%. Except for the dose-ranging study (Study 1) and the maintenance of abstinence study (Study 6), patients were treated for 12 weeks and then were followed for 40 weeks post-treatment. Most patients enrolled in these trials were white (79-96%). All studies enrolled almost equal numbers of men and women. The average age of patients in these studies was 43 years. Patients on average had smoked about 21 cigarettes per day for an average of approximately 25 years. Patients set a date to stop smoking (target quit date) with dosing starting 1 week before this date.

Seven additional studies evaluated the efficacy of CHANTIX in patients with cardiovascular disease, in patients with chronic obstructive pulmonary disease [see *Clinical Studies (14.7)*], in patients instructed to select their quit date within days 8 and 35 of treatment [see *Clinical Studies (14.4)*], patients with major depressive disorder [see *Clinical Studies (14.9)*], patients who had made a previous attempt to quit smoking with CHANTIX, and either did not succeed in quitting or relapsed after treatment [see *Clinical Studies (14.6)*], in patients without or with a history of psychiatric disorder enrolled in a postmarketing neuropsychiatric safety outcome trial [see *Warnings and Precautions (5.1)*, *Clinical Studies (14.10)*], and in patients who were not able or willing to quit abruptly and were instructed to quit gradually [see *Clinical studies (14.5)*].

In all studies, patients were provided with an educational booklet on smoking cessation and received up to 10 minutes of smoking cessation counseling at each weekly treatment visit according to Agency for Healthcare Research and Quality guidelines.

14.1 Initiation of Abstinence

Study 1

This was a six-week dose-ranging study comparing CHANTIX to placebo. This study provided initial evidence that CHANTIX at a total dose of 1 mg per day or 2 mg per day was effective as an aid to smoking cessation.

Study 2

This study of 627 patients compared CHANTIX 1 mg per day and 2 mg per day with placebo. Patients were treated for 12 weeks (including one-week titration) and then were followed for 40 weeks post-treatment. CHANTIX was given in two divided doses daily. Each dose of CHANTIX was given in two different regimens, with and without initial dose-titration, to explore the effect of different dosing regimens on tolerability. For the titrated groups, dosage was titrated up over the course of one week, with full dosage achieved starting with the second week of dosing. The titrated and nontitrated groups were pooled for efficacy analysis.

Forty-five percent of patients receiving CHANTIX 1 mg per day (0.5 mg twice daily) and 51% of patients receiving 2 mg per day (1 mg twice daily) had CO-confirmed continuous abstinence during weeks 9 through 12 compared to 12% of patients in the placebo group (Figure 1). In addition, 31% of the 1 mg per day group and 31% of the 2 mg per day group were continuously abstinent from one week after TQD through the end of treatment as compared to 8% of the placebo group.

Study 3

This flexible-dosing study of 312 patients examined the effect of a patient-directed dosing strategy of CHANTIX or placebo. After an initial one-week titration to a dose of 0.5 mg twice daily, patients could adjust their dosage as often as they wished between 0.5 mg once daily to 1 mg twice daily per day. Sixty-nine percent of patients titrated to the maximum allowable dose at any time during the study. For 44% of patients, the modal dose selected was 1 mg twice daily; for slightly over half of the study participants, the modal dose selected was 1 mg/day or less.

Of the patients treated with CHANTIX, 40% had CO-confirmed continuous abstinence during weeks 9 through 12 compared to 12% in the placebo group. In addition, 29% of the CHANTIX group were continuously abstinent from one week after TQD through the end of treatment as compared to 9% of the placebo group.

Study 4 and Study 5

These identical double-blind studies compared CHANTIX 2 mg per day, bupropion sustained-release (SR) 150 mg twice daily, and placebo. Patients were treated for 12 weeks and then were followed for 40 weeks post-treatment. The CHANTIX dosage of 1 mg twice daily was achieved using a titration of 0.5 mg once daily for the initial 3 days followed by 0.5 mg twice daily for the next 4 days. The bupropion SR dosage of 150 mg twice daily was achieved using a 3-day titration of 150 mg once daily. Study 4 enrolled 1022 patients and Study 5 enrolled 1023 patients. Patients inappropriate for bupropion treatment or patients who had previously used bupropion were excluded.

In Study 4, patients treated with CHANTIX had a superior rate of CO-confirmed abstinence during weeks 9 through 12 (44%) compared to patients treated with bupropion SR (30%) or placebo (17%). The bupropion SR quit rate was also superior to placebo. In addition, 29% of the CHANTIX group were continuously abstinent from one week after TQD through the end of treatment as compared to 12% of the placebo group and 23% of the bupropion SR group.

Similarly in Study 5, patients treated with CHANTIX had a superior rate of CO-confirmed abstinence during weeks 9 through 12 (44%) compared to patients treated with bupropion SR (30%) or placebo (18%). The bupropion SR quit rate was also superior to placebo. In addition, 29% of the CHANTIX group were continuously abstinent from one week after TQD through the end of treatment as compared to 11% of the placebo group and 21% of the bupropion SR group.

Figure 1: Continuous Abstinence, Weeks 9 through 12

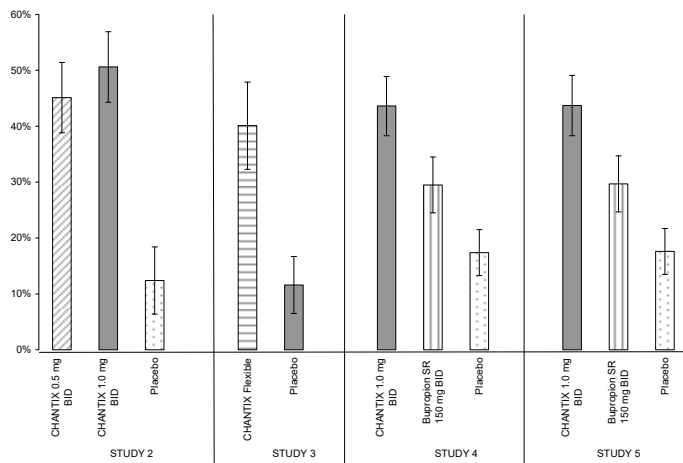

Table 7. Continuous Abstinence, Weeks 9 through 12 (95% confidence interval)

	CHANTIX 0.5 mg BID	CHANTIX 1 mg BID	CHANTIX Flexible	Bupropion SR	Placebo
Study 2	45% (39%, 51%)	51% (44%, 57%)			12% (6%, 18%)
Study 3			40% (32%, 48%)		12% (7%, 17%)
Study 4		44% (38%, 49%)		30% (25%, 35%)	17% (13%, 22%)
Study 5		44% (38%, 49%)		30% (25%, 35%)	18% (14%, 22%)

BID = twice daily

14.2 Urge to Smoke

Based on responses to the Brief Questionnaire of Smoking Urges and the Minnesota Nicotine Withdrawal scale “urge to smoke” item, CHANTIX reduced urge to smoke compared to placebo.

14.3 Long-Term Abstinence

Studies 1 through 5 included 40 weeks of post-treatment follow-up. In each study, CHANTIX-treated patients were more likely to maintain abstinence throughout the follow-up period than were patients treated with placebo (Figure 2, Table 8).

Figure 2: Continuous Abstinence, Weeks 9 through 52

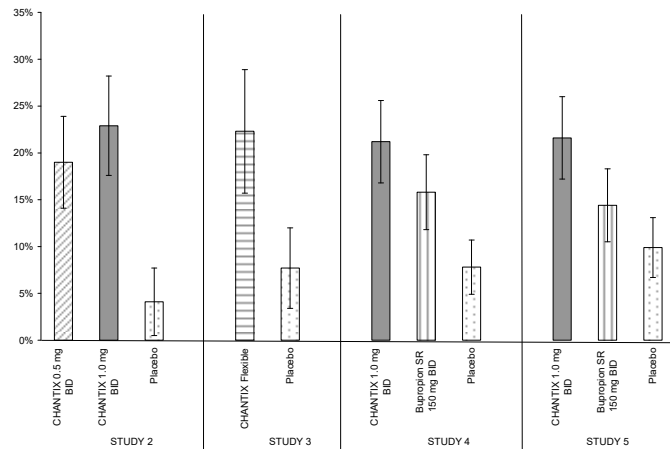

Table 8. Continuous Abstinence, Weeks 9 through 52 (95% confidence interval) Across Different Studies

	CHANTIX 0.5 mg BID	CHANTIX 1 mg BID	CHANTIX Flexible	Bupropion SR	Placebo
Study 2	19% (14%, 24%)	23% (18%, 28%)			4% (1%, 8%)
Study 3			22% (16%, 29%)		8% (3%, 12%)
Study 4		21% (17%, 26%)		16% (12%, 20%)	8% (5%, 11%)
Study 5		22% (17%, 26%)		14% (11%, 18%)	10% (7%, 13%)

BID = twice daily

Study 6

This study assessed the effect of an additional 12 weeks of CHANTIX therapy on the likelihood of long-term abstinence. Patients in this study (N=1927) were treated with open-label CHANTIX 1 mg twice daily for 12 weeks. Patients who had stopped smoking for at least a week by Week 12 (N= 1210) were then randomized to double-blind treatment with CHANTIX (1 mg twice daily) or placebo for an additional 12 weeks and then followed for 28 weeks post-treatment.

The continuous abstinence rate from Week 13 through Week 24 was higher for patients continuing treatment with CHANTIX (70%) than for patients switching to placebo (50%). Superiority to placebo was also maintained during 28 weeks post-treatment follow-up (CHANTIX 54% versus placebo 39%).

In Figure 3 below, the x-axis represents the study week for each observation, allowing a comparison of groups at similar times after discontinuation of CHANTIX; post-CHANTIX follow-up begins at Week 13 for the placebo group and Week 25 for the CHANTIX group. The y-axis represents the percentage of patients who had been abstinent for the last week of CHANTIX treatment and remained abstinent at the given timepoint.

Figure 3: Continuous Abstinence Rate during Nontreatment Follow-Up

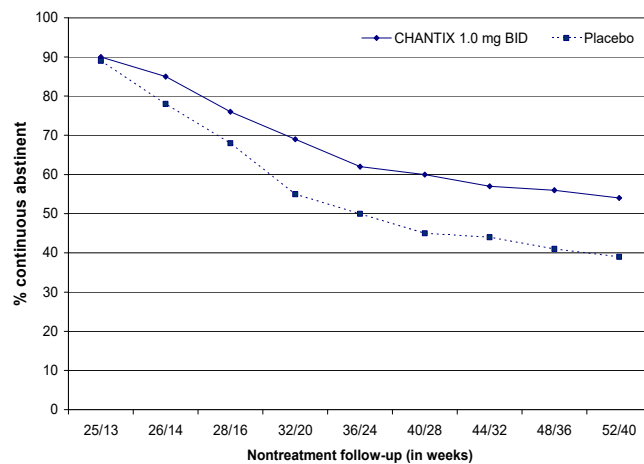

14.4 Alternative Instructions for Setting a Quit Date

CHANTIX was evaluated in a double-blind, placebo-controlled trial where patients were instructed to select a target quit date between Day 8 and Day 35 of treatment. Subjects were randomized 3:1 to CHANTIX 1 mg twice daily (N=486) or placebo (N=165) for 12 weeks of treatment and followed for another 12 weeks post-treatment. Patients treated with CHANTIX had a superior rate of CO-confirmed abstinence during weeks 9 through 12 (54%) compared to patients treated with placebo (19%) and from weeks 9 through 24 (35%) compared to subjects treated with placebo (13%).

14.5 Gradual Approach to Quitting Smoking

CHANTIX was evaluated in a 52-week double-blind placebo-controlled study of 1,510 subjects who were not able or willing to quit smoking within four weeks, but were willing to gradually reduce their smoking over a 12 week period before quitting. Subjects were randomized to either CHANTIX 1 mg twice daily (N=760) or placebo (N=750) for 24 weeks and followed up post-treatment through week 52. Subjects were instructed to reduce the number of cigarettes smoked by at least 50 percent by the end of the first four weeks of treatment, followed by a further 50 percent reduction from week four to week eight of treatment, with the goal of reaching complete abstinence by 12 weeks. After the initial 12-week reduction phase, subjects continued treatment for another 12 weeks. Subjects treated with CHANTIX had a significantly higher Continuous Abstinence Rate compared with placebo at weeks 15 through 24 (32% vs. 7%) and weeks 15 through 52 (24% vs. 6%).

14.6 Re-Treatment Study

CHANTIX was evaluated in a double-blind, placebo-controlled trial of patients who had made a previous attempt to quit smoking with CHANTIX, and either did not succeed in quitting or relapsed after treatment. Subjects were randomized 1:1 to CHANTIX 1 mg twice daily (N=249) or placebo (N=245) for 12 weeks of treatment and followed for 40 weeks post-treatment. Patients included in this study had taken CHANTIX for a smoking-cessation attempt in the past (for a total treatment duration of a minimum of two weeks), at least three months prior to study entry, and had been smoking for at least four weeks.

Patients treated with CHANTIX had a superior rate of CO-confirmed abstinence during weeks 9 through 12 (45%) compared to patients treated with placebo (12%) and from weeks 9 through 52 (20%) compared to subjects treated with placebo (3%).

Table 9. Continuous Abstinence (95% confidence interval), Re-Treatment Study

	Weeks 9 through 12		Weeks 9 through 52	
	CHANTIX 1 mg BID	Placebo	CHANTIX 1 mg BID	Placebo
Retreatment Study	45% (39%, 51%)	12% (8%, 16%)	20% (15%, 25%)	3% (1%, 5%)

BID = twice daily

14.7 Subjects with Chronic Obstructive Pulmonary Disease

CHANTIX was evaluated in a randomized, double-blind, placebo-controlled study of subjects aged ≥ 35 years with mild-to-moderate COPD with post-bronchodilator FEV₁/FVC <70% and FEV₁ $\geq 50\%$ of predicted normal value. Subjects were randomized to CHANTIX 1 mg twice daily (N=223) or placebo (N=237) for a treatment of 12 weeks and then were followed for 40 weeks post-treatment. Subjects treated with CHANTIX had a superior rate of CO-confirmed abstinence during weeks 9 through 12 (41%) compared to subjects treated with placebo (9%) and from week 9 through 52 (19%) compared to subjects treated with placebo (6%).

Table 10. Continuous Abstinence (95% confidence interval), Studies in Patients with Chronic Obstructive Pulmonary Disease (COPD)

	Weeks 9 through 12		Weeks 9 through 52	
	CHANTIX 1 mg BID	Placebo	CHANTIX 1 mg BID	Placebo
COPD Study	41% (34%, 47%)	9% (6%, 13%)	19% (14%, 24%)	6% (3%, 9%)

BID = twice daily

14.8 Subjects with Cardiovascular Disease and Other Cardiovascular Analyses

CHANTIX was evaluated in a randomized, double-blind, placebo-controlled study of subjects aged 35 to 75 years with stable, documented cardiovascular disease (diagnoses other than, or in addition to, hypertension) that had been diagnosed for more than 2 months. Subjects were randomized to CHANTIX 1 mg twice daily (N=353) or placebo (N=350) for a treatment period of 12 weeks and then were followed for 40 weeks post-treatment. Subjects treated with CHANTIX had a superior rate of CO-confirmed abstinence during weeks 9 through 12 (47%) compared to subjects treated with placebo (14%) and from week 9 through 52 (20%) compared to subjects treated with placebo (7%).

Table 11. Continuous Abstinence (95% confidence interval), Studies in Patients with Cardiovascular Disease (CVD)

	Weeks 9 through 12		Weeks 9 through 52	
	CHANTIX 1 mg BID	Placebo	CHANTIX 1 mg BID	Placebo
CVD Study	47% (42%, 53%)	14% (11%, 18%)	20% (16%, 24%)	7% (5%, 10%)

BID = twice daily

In this study, all-cause and CV mortality was lower in patients treated with CHANTIX, but certain nonfatal CV events occurred more frequently in patients treated with CHANTIX than in patients treated with placebo [see *Warnings and Precautions* (5.5), *Adverse Reactions* (6.1)]. Table 12 below shows mortality and the incidence of selected nonfatal serious CV events occurring more frequently in the CHANTIX arm compared to the placebo arm. These events were adjudicated by an independent blinded committee. Nonfatal serious CV events not listed occurred at the same incidence or more commonly in the placebo arm. Patients with more than one CV event of the same type are counted only once per row. Some of the patients requiring coronary revascularization underwent the procedure as part of management of nonfatal MI and hospitalization for angina.

Table 12. Mortality and Adjudicated Nonfatal Serious Cardiovascular Events in the Placebo-Controlled CHANTIX Trial in Patients with Stable Cardiovascular Disease

Mortality and Cardiovascular Events	CHANTIX (N=353) n (%)	Placebo (N=350) n (%)
<i>Mortality (Cardiovascular and All-cause up to 52 weeks)</i>		
Cardiovascular	1 (0.3)	2 (0.6)
All-cause	2 (0.6)	5 (1.4)

Nonfatal Cardiovascular Events (rate on CHANTIX > Placebo)		
<i>Up to 30 days after treatment</i>		
Nonfatal myocardial infarction	4 (1.1)	1 (0.3)
Nonfatal Stroke	2 (0.6)	0 (0)
<i>Beyond 30 days after treatment and up to 52 weeks</i>		
Nonfatal myocardial infarction	3 (0.8)	2 (0.6)
Need for coronary revascularization	7 (2.0)	2 (0.6)
Hospitalization for angina pectoris	6 (1.7)	4 (1.1)
Transient ischemia attack	1 (0.3)	0 (0)
New diagnosis of peripheral vascular disease (PVD) or admission for a PVD procedure	5 (1.4)	2 (0.6)

Following the CVD study, a meta-analysis of 15 clinical trials of ≥ 12 weeks treatment duration, including 7002 patients (4190 CHANTIX, 2812 placebo), was conducted to systematically assess the CV safety of CHANTIX. The study in patients with stable CV disease described above was included in the meta-analysis. There were lower rates of all-cause mortality (CHANTIX 6 [0.14%]; placebo 7 [0.25%]) and CV mortality (CHANTIX 2 [0.05%]; placebo 2 [0.07%]) in the CHANTIX arms compared with the placebo arms in the meta-analysis.

The key CV safety analysis included occurrence and timing of a composite endpoint of Major Adverse Cardiovascular Events (MACE), defined as CV death, nonfatal MI, and nonfatal stroke. These events included in the endpoint were adjudicated by a blinded, independent committee. Overall, a small number of MACE occurred in the trials included in the meta-analysis, as described in Table 13. These events occurred primarily in patients with known CV disease.

Table 13. Number of MACE cases, Hazard Ratio and Rate Difference in a Meta-Analysis of 15 Clinical Trials Comparing CHANTIX to Placebo*

	CHANTIX N=4190	Placebo N=2812
MACE cases, n (%)	13 (0.31%)	6 (0.21%)
Patient-years of exposure	1316	839
Hazard Ratio (95% CI)	1.95 (0.79, 4.82)	
Rate Difference per 1,000 patient-years (95% CI)	6.30 (-2.40, 15.10)	

*Includes MACE occurring up to 30 days post-treatment.

The meta-analysis showed that exposure to CHANTIX resulted in a hazard ratio for MACE of 1.95 (95% confidence interval from 0.79 to 4.82) for patients up to 30 days after treatment; this is equivalent to an estimated increase of 6.3 MACE events per 1,000 patient-years of exposure. The meta-analysis showed higher rates of CV endpoints in patients on CHANTIX relative to placebo across different time frames and pre-specified sensitivity analyses, including various study groupings and CV outcomes. Although these findings were not statistically significant they were consistent. Because the number of events was small overall, the power for finding a statistically significant difference in a signal of this magnitude is low.

Additionally, a cardiovascular endpoint analysis was added to the postmarketing neuropsychiatric safety outcome study along with a non-treatment extension, [see *Warnings and Precautions (5.5), Adverse Reactions (6.1), Clinical Studies (14.10)*].

14.9 Subjects with Major Depressive Disorder

CHANTIX was evaluated in a randomized, double-blind, placebo-controlled study of subjects aged 18 to 75 years with major depressive disorder without psychotic features (DSM-IV TR). If on medication, subjects were to be on a stable antidepressant regimen for at least two months. If not on medication, subjects were to have experienced a major depressive episode in the past 2 years, which was successfully treated. Subjects were randomized to CHANTIX 1 mg twice daily (N=256) or placebo (N=269) for a treatment of 12 weeks and then followed for 40 weeks post-treatment. Subjects treated with CHANTIX had a superior rate of CO-confirmed abstinence during weeks 9 through 12 (36%) compared to subjects treated with placebo (16%) and from week 9 through 52 (20%) compared to subjects treated with placebo (10%).

Table 14. Continuous Abstinence (95% confidence interval), Study in Patients with Major Depressive Disorder (MDD)

	Weeks 9 through 12		Weeks 9 through 52	
	CHANTIX 1 mg BID	Placebo	CHANTIX 1 mg BID	Placebo
MDD Study	36% (30%, 42%)	16% (11%, 20%)	20% (15%, 25%)	10% (7%, 14%)

BID = twice daily

14.10 Postmarketing Neuropsychiatric Safety Outcome Trial

CHANTIX was evaluated in a randomized, double-blind, active and placebo-controlled trial that included subjects without a history of psychiatric disorder (non-psychiatric cohort, N=3912) and with a history of psychiatric disorder (psychiatric cohort, N=4003). Subjects aged 18-75 years, smoking 10 or more cigarettes per day were randomized 1:1:1:1 to CHANTIX 1 mg BID, bupropion SR 150 mg BID, NRT patch 21 mg/day with taper or placebo for a treatment period of 12 weeks; they were then followed for another 12 weeks post-treatment. [See *Warnings and Precautions (5.1)*]

A composite safety endpoint intended to capture clinically significant neuropsychiatric (NPS) adverse events included the following NPS adverse events: anxiety, depression, feeling abnormal, hostility, agitation, aggression, delusions, hallucinations, homicidal ideation, mania, panic, paranoia, psychosis, irritability, suicidal ideation, suicidal behavior or completed suicide.

As shown in Table 15, the use of CHANTIX, bupropion, and NRT in the non-psychiatric cohort was not associated with an increased risk of clinically significant NPS adverse events compared with placebo. Similarly, in the non-psychiatric cohort, the use of CHANTIX was not associated with an increased risk of clinically significant NPS adverse events in the composite safety endpoint compared with bupropion or NRT.

Table 15. Number of Patients with Clinically Significant or Serious NPS Adverse Events by Treatment Group Among Patients without a History of Psychiatric Disorder

	CHANTIX (N=975) n (%)	Bupropion (N=968) n (%)	NRT (N=987) n (%)	Placebo (N=982) n (%)
Clinically Significant NPS	30 (3.1)	34 (3.5)	33 (3.3)	40 (4.1)
Serious NPS	1 (0.1)	5 (0.5)	1 (0.1)	4 (0.4)
Psychiatric Hospitalizations	1 (0.1)	2 (0.2)	0 (0.0)	1 (0.1)

As shown in Table 16, there were more clinically significant NPS adverse events reported in patients in the psychiatric cohort in each treatment group compared with the non-psychiatric cohort. The incidence of events in the composite endpoint was higher for each of the active treatments compared to placebo: Risk Differences (RDs) (95%CI) vs placebo were 2.7% (-0.05, 5.4) for CHANTIX, 2.2% (-0.5, 4.9) for bupropion, and 0.4% (-2.2, 3.0) for NRT transdermal nicotine.

Table 16. Number of Patients with Clinically Significant or Serious NPS Adverse Events by Treatment Group Among Patients with a History of Psychiatric Disorder

	CHANTIX (N=1007) n (%)	Bupropion (N=1004) n (%)	NRT (N=995) n (%)	Placebo (N=997) n (%)
Clinically Significant NPS	123 (12.2)	118 (11.8)	98 (9.8)	95 (9.5)
Serious NPS	6 (0.6)	8 (0.8)	4 (0.4)	6 (0.6)
Psychiatric hospitalizations	5 (0.5)	8 (0.8)	4 (0.4)	2 (0.2)

There was one completed suicide, which occurred during treatment in a patient treated with placebo in the non-psychiatric cohort. There were no completed suicides reported in the psychiatric cohort.

In both cohorts, subjects treated with CHANTIX had a superior rate of CO-confirmed abstinence during weeks 9 through 12 and 9 through 24 compared to subjects treated with bupropion, nicotine patch and placebo.

Table 17 Continuous Abstinence (95% confidence interval), Study in Patients with or without a History of Psychiatric Disorder

	CHANTIX 1 mg BID	Bupropion SR 150 mg BID	NRT 21 mg/day with taper	Placebo
Weeks 9 through 12				
Non-Psychiatric Cohort	38% (35%, 41%)	26% (23%, 29%)	26% (24%, 29%)	14% (12%, 16%)
Psychiatric Cohort	29% (26%, 32%)	19% (17%, 22%)	20% (18%, 23%)	11% (10%, 14%)
Weeks 9 through 24				
Non-Psychiatric Cohort	25% (23%, 28%)	19% (16%, 21%)	18% (16%, 21%)	11% (9%, 13%)
Psychiatric Cohort	18% (16%, 21%)	14% (12%, 16%)	13% (11%, 15%)	8% (7%, 10%)

BID = twice daily

Cardiovascular Outcome Analysis

To obtain another source of data regarding the CV risk of CHANTIX, a cardiovascular endpoint analysis was added to the postmarketing neuropsychiatric safety outcome study along with a non-treatment extension. In the parent study (N=8027), subjects aged 18-75 years, smoking 10 or more cigarettes per day were randomized 1:1:1:1 to CHANTIX 1 mg BID, bupropion SR 150 mg BID, nicotine replacement therapy (NRT) patch 21 mg/day or placebo for a treatment period of 12 weeks; they were then followed for another 12 weeks post-treatment. The extension study enrolled 4590 (57.2%) of the 8027 subjects who were randomized and treated in the parent study and followed them for additional 28 weeks. Of all treated subjects, 1743 (21.7%) had a medium CV risk and 640 (8.0%) had a high CV risk, as defined by Framingham score. Note that one site from the parent study was excluded in the assessment of CV safety and two sites were excluded in the assessment of neuropsychiatric safety.

The primary CV endpoint was the time to major adverse CV event (MACE), defined as CV death, nonfatal myocardial infarction or nonfatal stroke during treatment. Deaths and CV events were adjudicated by a blinded, independent committee. Table 18 below shows the incidence of MACE and Hazard Ratios compared to placebo for all randomized subjects exposed to at least 1 partial dose of study treatment in the parent study.

Table 18. The Incidence of MACE and Hazard Ratios in the Cardiovascular Safety Assessment Trial in Subjects without or with a History of Psychiatric Disorder

	CHANTIX N=2006	Bupropion N=1997	NRT N=2017	Placebo N=2007
During treatment*				
MACE, n [IR]	1 [2.4]	2 [4.9]	1 [2.4]	4 [9.8]
Hazard Ratio (95% CI) vs. placebo	0.24 (0.03, 2.18)	0.49 (0.09, 2.69)	0.24 (0.03, 2.18)	
Through end of study**				
MACE, n [IR]	3 [2.1]	9 [6.3]	6 [4.3]	8 [5.7]
Hazard Ratio (95% CI) vs. placebo	0.36 (0.10, 1.36)	1.09 (0.42, 2.83)	0.74 (0.26, 2.13)	

[IR] indicates incidence rate per 1000 person-years

*during treatment in the parent neuropsychiatric safety study

**either the end of the extension study or the end of parent neuropsychiatric safety study for those subjects not enrolled into the extension study

For this study, MACE+ was defined as any MACE or a new onset or worsening peripheral vascular disease (PVD) requiring intervention, a need for coronary revascularization, or hospitalization for unstable angina. Incidence rates of MACE+ and all-cause mortality for all randomized subjects exposed to at least 1 partial dose of study treatment in the parent study are shown for all treatment groups during treatment, and through end of study in the Table 19 below.

Table 19. The Incidence of MACE+ and All-Cause Death in the Cardiovascular Safety Assessment Trial in Subjects without or with a History of Psychiatric Disorder

	CHANTIX N=2006	Bupropion N=1997	NRT N=2017	Placebo N=2007
During treatment*				
MACE+, n [IR]	5 [12.1]	4 [9.9]	2 [4.8]	5 [12.2]
All-cause deaths, n [IR]	0	2 [4.9]	0	2 [4.9]
Through end of study**				
MACE+, n [IR]	10 [6.9]	15 [10.5]	10 [7.1]	12 [8.6]
All-cause deaths, n [IR]	2 [1.4]	4 [2.8]	3 [2.1]	4 [2.9]

[IR] indicates incidence rate per 1000 person-years

*during treatment in the parent neuropsychiatric safety study

**either the end of the extension study or the end of the parent neuropsychiatric safety study for those subjects not enrolled into the extension study

The number of subjects who experienced MACE, MACE+ and all-cause death was similar or lower among patients treated with CHANTIX than patients treated with placebo. The number of events observed overall was too low to distinguish meaningful differences between the treatment arms.

16 HOW SUPPLIED/STORAGE AND HANDLING

CHANTIX is supplied for oral administration in two strengths: a 0.5 mg capsular biconvex, white to off-white, film-coated tablet debossed with "Pfizer" on one side and "CHX 0.5" on the other side and a 1 mg capsular biconvex, light blue film-coated tablet debossed with "Pfizer" on one side and "CHX 1.0" on the other side. CHANTIX is supplied in the following package configurations:

	Description	NDC
Packs	Starting 4-week card: 0.5 mg x 11 tablets and 1 mg x 42 tablets	NDC 0069-0471-03
	Continuing 4-week card: 1 mg x 56 tablets	NDC 0069-0469-03
	Starting Month Box: 0.5 mg x 11 tablets and 1 mg x 42 tablets	NDC 0069-0471-03
	Continuing Month Box: 1 mg x 56 tablets	NDC 0069-0469-03
Bottles	0.5 mg - bottle of 56	NDC 0069-0468-56
	1 mg - bottle of 56	NDC 0069-0469-56

Store at 25°C (77°F); excursions permitted to 15–30°C (59–86°F) (see USP Controlled Room Temperature).

17 PATIENT COUNSELING INFORMATION

See FDA-approved patient labeling (Medication Guide)

Initiate Treatment and Continue to Attempt to Quit if Lapse

Instruct patients to set a date to quit smoking and to initiate CHANTIX treatment one week before the quit date. Alternatively, the patient can begin CHANTIX dosing and then set a date to quit smoking between days 8 and 35 of treatment. Encourage patients to continue to attempt to quit if they have early lapses after quit day [see Dosage and Administration (2.1)].

For patients who are sure that they are not able or willing to quit abruptly, a gradual approach to quitting smoking with CHANTIX may be considered. Patients should begin CHANTIX dosing and reduce smoking during the first 12 weeks of treatment, then quit by the end of that period and continue treatment for an additional 12 weeks for a total of 24 weeks [see Dosage and Administration (2.1)].

Encourage patients who are motivated to quit and who did not succeed in stopping smoking during prior CHANTIX therapy for reasons other than intolerability due to adverse events, or who relapsed after treatment to make another attempt with CHANTIX once factors contributing to the failed attempt have been identified and addressed [see *Dosage and Administration (2.1)*, *Clinical Studies (14.6)*].

How to Take

Advise patients that CHANTIX should be taken orally after eating, and with a full glass of water [see *Dosage and Administration (2.1)*].

Starting Week Dosage

Instruct patients on how to titrate CHANTIX, beginning at a dose of 0.5 mg/day. Explain that one 0.5 mg tablet should be taken daily for the first three days, and that for the next four days, one 0.5 mg tablet should be taken in the morning and one 0.5 mg tablet should be taken in the evening [see *Dosage and Administration (2.1)*].

Continuing Weeks Dosage

Advise patients that, after the first seven days, the dose should be increased to one 1 mg tablet in the morning and one 1 mg tablet in the evening [see *Dosage and Administration (2.1)*].

Dosage Adjustment for CHANTIX or Other Drugs

Inform patients that nausea and insomnia are side effects of CHANTIX and are usually transient; however, advise patients that if they are persistently troubled by these symptoms, they should notify the prescribing physician so that a dose reduction can be considered.

Inform patients that some drugs may require dose adjustment after quitting smoking [see *Dosage and Administration (2.1)*].

Counseling and Support

Provide patients with educational materials and necessary counseling to support an attempt at quitting smoking [see *Dosage and Administration (2.1)*].

Neuropsychiatric Adverse Events

Inform patients that some patients have experienced changes in mood (including depression and mania), psychosis, hallucinations, paranoia, delusions, homicidal ideation, aggression, hostility, agitation, anxiety, and panic, as well as suicidal ideation and suicide when attempting to quit smoking while taking CHANTIX. Instruct patients to discontinue CHANTIX and contact a healthcare professional if they experience such symptoms [see *Warnings and Precautions (5.1)*, *Adverse Reactions (6.2)*].

History of Psychiatric Illness

Encourage patients to reveal any history of psychiatric illness prior to initiating treatment.

Nicotine Withdrawal

Inform patients that quitting smoking, with or without CHANTIX, may be associated with nicotine withdrawal symptoms (including depression or agitation) or exacerbation of pre-existing psychiatric illness.

Seizures

Encourage patients to report any history of seizures or other factors that can lower seizure threshold. Instruct patients to discontinue CHANTIX and contact a healthcare provider immediately if they experience a seizure while on treatment [see *Warnings and Precautions (5.2)*].

Interaction with Alcohol

Advise patients to reduce the amount of alcohol they consume while taking CHANTIX until they know whether CHANTIX affects their tolerance for alcohol [see *Warnings and Precautions (5.3)*, *Adverse Reactions (6.2)*].

Driving or Operating Machinery

Advise patients to use caution driving or operating machinery until they know how quitting smoking and/or varenicline may affect them [see *Warnings and Precautions (5.4)*].

Cardiovascular Events

Patients should be instructed to notify their healthcare providers of symptoms of new or worsening cardiovascular events and to seek immediate medical attention if they experience signs and symptoms of myocardial infarction or stroke [see *Warnings and Precautions (5.5)*, *Adverse Reactions (6.1)*].

Somnambulism

Patients should be instructed to discontinue CHANTIX and notify their healthcare providers if they experience somnambulism [see *Warnings and Precautions (5.6)*].

Angioedema

Inform patients that there have been reports of angioedema, with swelling of the face, mouth (lip, gum, tongue) and neck (larynx and pharynx) that can lead to life-threatening respiratory compromise. Instruct patients to discontinue CHANTIX and immediately seek medical care if they experience these symptoms [see *Warnings and Precautions (5.7)*, *Adverse Reactions (6.2)*].

Serious Skin Reactions

Inform patients that serious skin reactions, such as Stevens-Johnson Syndrome and erythema multiforme, were reported by some patients taking CHANTIX. Advise patients to stop taking CHANTIX at the first sign of rash with mucosal lesions or skin reaction and contact a healthcare provider immediately [*see Warnings and Precautions (5.8), Adverse Reactions (6.2)*].

Vivid, Unusual, or Strange Dreams

Inform patients that they may experience vivid, unusual or strange dreams during treatment with CHANTIX.

Pregnancy and Lactation

Patients who are pregnant or breastfeeding or planning to become pregnant should be advised of: the risks of smoking to a pregnant mother and her developing baby, the potential risks of CHANTIX use during pregnancy and breastfeeding, and the benefits of smoking cessation with and without CHANTIX. Advise breastfeeding women to monitor the infant for seizures and vomiting [*see Use in Specific Populations (8.1 and 8.2)*].

This product's label may have been updated. For full prescribing information, please visit www.pfizer.com



LAB- 0327-23.1

MEDICATION GUIDE
CHANTIX® (CHANT-iks)
(varenicline)
Tablets

What is the most important information I should know about CHANTIX?

When you try to quit smoking, with or without CHANTIX, you may have symptoms that may be due to nicotine withdrawal, including:

- urge to smoke
- depressed mood
- trouble sleeping
- irritability
- frustration
- anger
- feeling anxious
- difficulty concentrating
- restlessness
- decreased heart rate
- increased appetite
- weight gain

Some people have even experienced suicidal thoughts when trying to quit smoking without medication. Sometimes quitting smoking can lead to worsening of mental health problems that you already have, such as depression.

Some people have had serious side effects while taking CHANTIX to help them quit smoking, including:

New or worse mental health problems, such as changes in behavior or thinking, aggression, hostility, agitation, depressed mood, or suicidal thoughts or actions. Some people had these symptoms when they began taking CHANTIX, and others developed them after several weeks of treatment, or after stopping CHANTIX. These symptoms happened more often in people who had a history of mental health problems before taking CHANTIX, than in people without a history of mental health problems.

Stop taking CHANTIX and call your healthcare provider right away if you, your family, or caregiver notice any of these symptoms. Work with your healthcare provider to decide whether you should continue to take CHANTIX. In many people, these symptoms went away after stopping CHANTIX, but in some people symptoms continued after stopping CHANTIX. It is important for you to follow-up with your healthcare provider until your symptoms go away.

Before taking CHANTIX, tell your healthcare provider if you have ever had depression or other mental health problems. You should also tell your healthcare provider about any symptoms you had during other times you tried to quit smoking, with or without CHANTIX.

What is CHANTIX?

CHANTIX is a prescription medicine to help people stop smoking.

Quitting smoking can lower your chances of having lung disease, heart disease or getting certain types of cancer that are related to smoking.

CHANTIX has not been shown to be effective in children 16 years of age and under. CHANTIX should not be used in children 16 years of age and under.

It is not known if CHANTIX is safe and effective when used with other stop smoking medicines.

Who should not take CHANTIX?

Do not take CHANTIX if you have had a serious allergic or skin reaction to CHANTIX. Symptoms may include:

- swelling of the face, mouth (tongue, lips, gums), throat or neck
- trouble breathing
- rash, with peeling skin
- blisters in your mouth

What should I tell my healthcare provider before taking CHANTIX?

See “What is the most important information I should know about CHANTIX?”

Before you take CHANTIX, tell your healthcare provider if you:

- use other treatments to quit smoking. Using CHANTIX with a nicotine patch may cause nausea, vomiting, headache, dizziness, upset stomach, and tiredness to happen more often than if you just use a nicotine patch alone.
- have kidney problems or get kidney dialysis. Your healthcare provider may prescribe a lower dose of CHANTIX for you.
- have a history of seizures
- drink alcohol
- have heart or blood vessel problems
- have any other medical conditions
- are pregnant or plan to become pregnant.
- are breastfeeding. It is not known if CHANTIX passes into breast milk. If you breastfeed and take CHANTIX, monitor your baby for seizures as well as spitting up or vomiting more than normal.

Tell your healthcare provider about all the medicines you take, including prescription and over-the-counter medicines, vitamins and herbal supplements. Your healthcare provider may need to change the dose of some of your medicines when you stop smoking.

You should not use CHANTIX while using other medicines to quit smoking. Tell your healthcare provider if you use other treatments to quit smoking.

Know the medicines you take. Keep a list of them with you to show your healthcare provider and pharmacist when you get a new medicine.

How should I take CHANTIX?

- There are 3 ways that you can use CHANTIX to help you quit smoking. Talk to your healthcare provider about the following 3 ways to use CHANTIX:
 - Choose a **quit date** when you will stop smoking. Start taking CHANTIX 1 week (7 days) before your quit date. Take CHANTIX for 12 weeks.
- OR**
- Start taking CHANTIX before you choose a **quit date**. Pick a date to quit smoking that is between days 8 and 35 of treatment. Take CHANTIX for 12 weeks.
- OR**
- If you are sure that you are not able or willing to quit smoking right away, start taking CHANTIX and reduce smoking during the first 12 weeks of treatment, as follows:

Weeks 1 through 4	Reduce your smoking to reach one-half of your starting daily number of cigarettes. Example: If you usually smoke 20 cigarettes each day, reduce your smoking to 10 cigarettes each day during weeks 1 through 4.
Weeks 5 through 8	Reduce your smoking to reach one-quarter of your starting daily number of cigarettes. Example: If you usually smoked 20 cigarettes each day, reduce your smoking to 5 cigarettes each day during weeks 5 through 8.
Weeks 9 through 12	Keep reducing your smoking until you are no longer smoking (you reach zero cigarettes each day).

Aim to quit by the end of the 12th week of treatment, or sooner if you feel ready. Continue to take CHANTIX for another 12 weeks, for a total of 24 weeks of treatment.

Starting CHANTIX before your **quit date** gives CHANTIX time to build up in your body. You can keep smoking during this time. Take CHANTIX exactly as prescribed by your healthcare provider.

- CHANTIX comes as a white tablet (0.5 mg) and a blue tablet (1 mg). You start with the white tablet and then usually go to the blue tablet. See the chart below for dosing instructions for adults.

Day 1 to Day 3	<ul style="list-style-type: none">○ <u>White</u> tablet (0.5 mg)○ Take 1 tablet each day
Day 4 to Day 7	<ul style="list-style-type: none">○ <u>White</u> tablet (0.5 mg)○ Take 1 in the morning and 1 in the evening
Day 8 to end of treatment	<ul style="list-style-type: none">○ <u>Blue</u> tablet (1 mg)○ Take 1 in the morning and 1 in the evening

- Make sure that you try to stop smoking on your quit date. If you slip-up and smoke, try again. Some people need to take CHANTIX for a few weeks for CHANTIX to work best.
- Most people will take CHANTIX for up to 12 weeks. If you have completely quit smoking by 12 weeks, your healthcare provider may prescribe CHANTIX for another 12 weeks to help you stay cigarette-free.
- Take CHANTIX after eating and with a full glass (8 ounces) of water.
- This dosing schedule may not be right for everyone. Talk to your healthcare provider if you are having side effects such as nausea, strange dreams, or sleep problems. Your healthcare provider may want to reduce your dose.
- If you miss a dose of CHANTIX, take it as soon as you remember. If it is almost time for your next dose, skip the missed dose. Just take your next dose at your regular time.

What should I avoid while taking CHANTIX?

- Use caution when driving or operating machinery until you know how CHANTIX affects you. CHANTIX may make you feel sleepy, dizzy, or have trouble concentrating, making it hard to drive or perform other activities safely.
- Decrease the amount of alcoholic beverages that you drink during treatment with CHANTIX until you know if CHANTIX affects your ability to tolerate alcohol. Some people have experienced the following when drinking alcohol during treatment with CHANTIX:
 - increased drunkenness (intoxication)
 - unusual or sometimes aggressive behavior
 - no memory of things that have happened

What are the possible side effects of CHANTIX?

Serious side effects of CHANTIX may include:

- **See “What is the most important information I should know about CHANTIX?”**
- **Seizures.** Some people have had seizures during treatment with CHANTIX. In most cases, the seizures have happened during the first month of treatment with CHANTIX. If you have a seizure during treatment with CHANTIX, stop taking CHANTIX and contact your healthcare provider right away.
- **New or worse heart or blood vessel (cardiovascular) problems,** mostly in people, who already have cardiovascular problems. Tell your healthcare provider if you have any changes in symptoms during treatment with CHANTIX.

Get emergency medical help right away if you have any of the following symptoms of a heart attack, including:

- chest discomfort (uncomfortable pressure, squeezing, fullness or pain) that lasts more than a few minutes, or that goes away and comes back
- pain or discomfort in one or both arms, back, neck, jaw or stomach
- shortness of breath, sweating, nausea, vomiting, or feeling lightheaded associated with chest discomfort
- **Sleepwalking** can happen with CHANTIX, and can sometimes lead to behavior that is harmful to you or other people, or to property. Stop taking CHANTIX and tell your healthcare provider if you start sleepwalking.
- **Allergic reactions** can happen with CHANTIX. Some of these allergic reactions can be life-threatening.
- **Serious skin reactions**, including rash, swelling, redness, and peeling of the skin. Some of these skin reactions can become life-threatening.

Stop taking CHANTIX and get medical help right away if you have any of the following symptoms:

- swelling of the face, mouth (tongue, lips, and gums), throat or neck
- trouble breathing
- rash with peeling skin
- blisters in your mouth

The most common side effects of CHANTIX include:

- nausea
- sleep problems (trouble sleeping or vivid, unusual, or strange dreams)
- constipation
- gas
- vomiting

Tell your healthcare provider about side effects that bother you or that do not go away.

These are not all the side effects of CHANTIX. Ask your healthcare provider or pharmacist for more information.

Call your doctor for medical advice about side effects. You may report side effects to FDA at 1-800-FDA-1088.

How should I store CHANTIX?

- Store CHANTIX at room temperature, between 68°F to 77°F (20°C to 25°C).

Keep CHANTIX and all medicines out of the reach of children.

General information about the safe and effective use of CHANTIX.

Medicines are sometimes prescribed for purposes other than those listed in a Medication Guide. Do not use CHANTIX for a condition for which it was not prescribed. Do not give your CHANTIX to other people, even if they have the same symptoms that you have. It may harm them. If you would like more information, talk with your healthcare provider. You can ask your healthcare provider or pharmacist for information about CHANTIX that is written for healthcare professionals. For more information about CHANTIX and tips on how to quit smoking, go to www.CHANTIX.com or call 1-877-242-6849. If you are motivated to quit smoking and did not succeed during prior CHANTIX treatment for reasons other than side effects, or if you returned to smoking after treatment, speak with your healthcare provider about whether another course of CHANTIX therapy may be right for you.

What are the ingredients in CHANTIX?

Active ingredient: varenicline tartrate

Inactive ingredients: microcrystalline cellulose, anhydrous dibasic calcium phosphate, croscarmellose sodium, colloidal silicon dioxide, magnesium stearate, Opadry® White (for 0.5 mg), Opadry® Blue (for 1 mg), and Opadry® Clear.



LAB-0328-16.1

This Medication Guide has been approved by the U.S. Food and Drug Administration.

Revised: Feb 2019

PRODUCT MONOGRAPH
INCLUDING PATIENT MEDICATION INFORMATION

^{Pr}**COPAXONE**[®]

glatiramer acetate injection

20 mg / 1 mL and 40 mg / 1 mL
Pre-filled syringes for Subcutaneous Injection

Immunomodulator

Date of Revision: June 5, 2020

Distributed by:
Teva Canada Limited
Toronto, Ontario M1B 2K9

Manufactured for:
Teva Canada Innovation
Montréal, Quebec H2Z 1S8

Submission Control No: 236453

COPAXONE is a registered trade-mark of Teva Pharmaceutical Industries, Ltd.

RECENT MAJOR LABEL CHANGES

Warnings and Precautions (6)

Adverse Reactions, Post-Market Adverse Reactions (7.5)

TABLE OF CONTENTS

PART I: HEALTH PROFESSIONAL INFORMATION.....	4
1 INDICATIONS.....	4
1.1 Pediatrics.....	4
1.2 Geriatrics.....	4
2 CONTRAINDICATIONS.....	4
3 DOSAGE AND ADMINISTRATION.....	4
3.1 Dosing Considerations.....	4
3.2 Recommended Dose and Dosage Adjustment.....	5
3.3 Administration.....	5
3.4 Missed Dose.....	5
4 OVERDOSAGE.....	5
5 DOSAGE FORMS, STRENGTHS, COMPOSITION AND PACKAGING.....	6
6 WARNINGS AND PRECAUTIONS.....	6
6.1 Special Populations.....	9
6.1.1 Pregnant Women.....	9
6.1.2 Breast-feeding.....	9
6.1.3 Pediatrics.....	9
6.1.4 Geriatrics.....	9
7 ADVERSE REACTIONS.....	9
7.1 Adverse Reaction Overview.....	10
7.2 Clinical Trial Adverse Reactions.....	11
7.3 Other Clinical Trial Adverse Reactions.....	16
7.4 Abnormal Laboratory Findings: Hematologic, Clinical Chemistry and Other Quantitative Data.....	19
7.5 Post-Market Adverse Reactions.....	19
8 DRUG INTERACTIONS.....	21

8.1	Overview.....	21
9	ACTION AND CLINICAL PHARMACOLOGY	21
9.1	Mechanism of action.....	21
9.2	Pharmacokinetics.....	21
10	STORAGE, STABILITY AND DISPOSAL	21
	PART II: SCIENTIFIC INFORMATION	23
11	PHARMACEUTICAL INFORMATION	23
12	CLINICAL TRIALS.....	24
13	PHARMACOLOGY.....	29
14	NON-CLINICAL TOXICOLOGY	30
	PATIENT MEDICATION INFORMATION.....	32

PART I: HEALTH PROFESSIONAL INFORMATION

1 INDICATIONS

COPAXONE (glatiramer acetate) is indicated for:

20 mg/mL once-daily:

Treatment of ambulatory patients with Relapsing Remitting Multiple Sclerosis (RRMS), including patients who have experienced a single demyelinating event and have lesions typical of multiple sclerosis on brain MRI:

- To decrease the frequency of clinical exacerbations
- To reduce the number and volume of active brain lesions identified on Magnetic Resonance Imaging (MRI) scans.

40 mg/mL three times-a-week:

Treatment of ambulatory patients with Relapsing Remitting Multiple Sclerosis (RRMS):

- To decrease the frequency of clinical exacerbations
- To reduce the number and volume of active brain lesions identified on Magnetic Resonance Imaging (MRI) scans.

The safety and efficacy of COPAXONE in chronic progressive MS have not been established.

1.1 Pediatrics

Pediatrics (under 18 years of age): No data are available to Health Canada; therefore, Health Canada has not authorized an indication for pediatric use.

1.2 Geriatrics

Geriatrics (over 65 years of age): No data are available to Health Canada; therefore, Health Canada has not authorized an indication for geriatric use.

2 CONTRAINDICATIONS

COPAXONE is contraindicated in patients who are hypersensitive to this drug or to any ingredient in the formulation, including any non-medicinal ingredient, or component of the container. For a complete listing, see Dosage Forms, Strengths, Composition and Packaging.

3 DOSAGE AND ADMINISTRATION

3.1 Dosing Considerations

COPAXONE should only be prescribed by (or following consultation with) clinicians who are experienced in the diagnosis and management of Multiple Sclerosis.

The only recommended route of administration of COPAXONE (glatiramer acetate) injection is the subcutaneous route. COPAXONE should not be administered by the intravenous route.

3.2 Recommended Dose and Dosage Adjustment

The recommended dose and dosing schedule of COPAXONE (glatiramer acetate injection) for the treatment of Relapsing Remitting MS depends on the product strength selected:

- **COPAXONE 20 mg/mL:** Administer once per day
- or
- **COPAXONE 40 mg/mL:** Administer three times per week and at least 48 hours apart

COPAXONE 20 mg/mL and COPAXONE 40 mg/mL are not interchangeable.

Health Canada has not authorized an indication for pediatric use (see Section 1.1: Pediatrics).

3.3 Administration

Please see **Part III - Patient Medication Information (Instructions for Use)** for instructions on the preparation and injection of COPAXONE.

3.4 Missed Dose

If a dose is missed it should be taken as soon as possible. If, however, it is closer to the time of the next dose, skip the missed dose and resume at the usual dosing schedule.

For COPAXONE 20 mg/mL, avoid giving 2 injections in the same 12-hour period.

For COPAXONE 40 mg/mL, ensure injections are at least 48 hours apart.

4 OVERDOSAGE

Cases of overdose with COPAXONE (up to 300 mg glatiramer acetate) have been reported. These cases were not associated with any adverse reactions other than those mentioned in **ADVERSE REACTIONS**. In case of overdose, patients should be monitored and the appropriate symptomatic and supportive therapy instituted.

For management of a suspected drug overdose, contact your regional poison control centre.

5 DOSAGE FORMS, STRENGTHS, COMPOSITION AND PACKAGING

Table 1: Dosage Forms, Strengths, Composition and Packaging

Route of Administration	Dosage Form / Strength/Composition	Nonmedicinal Ingredients
Subcutaneous	20 mg / 1 mL Prefilled syringe	40 mg mannitol in sterile water for injection
	40 mg / 1 mL Prefilled syringe	40 mg mannitol in sterile water for injection

- COPAXONE (glatiramer acetate injection) single-use **20 mg/1 mL** pre-filled syringes have white plunger rods. Each pre-filled syringe contains glatiramer acetate, mannitol and sterile water for injection. Available in packs of 30 single-use 20 mg/1 mL pre-filled glass syringes.
- COPAXONE (glatiramer acetate injection) single use **40 mg/1 mL** prefilled syringes have blue plunger rods. Each pre-filled syringe contains glatiramer acetate, mannitol and sterile water for injection. Available in packs of 12 single-use 40 mg/1 mL prefilled glass syringes.

6 WARNINGS AND PRECAUTIONS

The only recommended route of administration of COPAXONE (glatiramer acetate) injection is the subcutaneous route. COPAXONE should not be administered by the intravenous or intramuscular routes.

General

Patients should be instructed in aseptic self-injection techniques to assure the safe administration of COPAXONE (glatiramer acetate), including a careful review of the **Part III – Patient Medication Information**. The first injection should be performed under the supervision of an appropriately qualified health care professional. Patient understanding and use of aseptic self-injection techniques and procedures should be periodically re-evaluated. Patients should be cautioned against the re-use of needles or syringes and instructed in safe disposal procedures. A puncture-resistant container for disposal of used needles and syringes should be used by the patient. Patients should be instructed on the safe disposal of full containers.

Localized Adverse Reactions Associated with Subcutaneous Use

At injection sites, localized lipoatrophy and, rarely, injection site skin necrosis have been reported during clinical trials and post-marketing experience (see **ADVERSE REACTIONS**). Lipoatrophy may occur after treatment onset (sometimes as early as several months) and may be permanent. There is no known therapy for lipoatrophy. To assist in possibly minimizing these events the patient should be advised to follow proper injection technique and to rotate injection areas and sites on a regular basis (see **Part III – Patient Medication Information**).

Carcinogenesis and Mutagenesis

Preclinical studies to assess the carcinogenic potential of glatiramer acetate in mice and rats do not suggest any evidence of carcinogenic potential related to glatiramer acetate administered

subcutaneously at dose levels of up to 30 mg/kg/day in rats and 60 mg/kg/day in mice (see **NON-CLINICAL TOXICOLOGY: Carcinogenicity**). The relevance of these findings for humans is unknown (see **WARNINGS AND PRECAUTIONS: Immune - Considerations Involving the Use of a Product Capable of Modifying Immune Responses**).

Cardiovascular

Symptoms of Potentially Cardiac Origin: A number of patients exposed to either COPAXONE 20 mg/mL once per day in 4 placebo-controlled trials, or COPAXONE 40 mg/mL three times per week in a single placebo-controlled trial, experienced at least one episode of what was described as transient chest pain (see **ADVERSE REACTIONS**). While some of these episodes occurred in the context of the Immediate Post-Injection Reaction (see **ADVERSE REACTIONS**), many did not. The pathogenesis of this symptom is unknown. Patients in controlled clinical trials were free of significant cardiovascular problems (New York Heart Association Class I and II) and thus the risks associated with COPAXONE treatment for Multiple Sclerosis patients with comorbid cardiovascular disease are unknown.

Immediate Post-Injection Reaction: COPAXONE has been associated with a constellation of symptoms appearing immediately after injection that included at least two of the following: flushing, chest pain, palpitations, anxiety, dyspnea, constriction of the throat and urticaria (see **ADVERSE REACTIONS: Immediate Post-Injection Reaction**).

Hepatic

Very rare cases of severe liver injury, including liver failure, hepatitis with jaundice, and extremely rare cases of fulminant hepatitis leading to liver transplant, have been reported with Copaxone during postmarketing experience in patients with and without relevant risk factors in their medical history, such as history of drug induced liver events with other disease modifying therapies (DMTs) indicated for the treatment of multiple sclerosis, concomitant treatment with drugs with known Drug Induced Liver Injury (DILI) risk or medical history of liver impairment. Hepatic adverse events have occurred from days to years after initiating treatment with Copaxone and with a similar profile with both dose regimens (20 mg/mL daily and 40 mg/mL TIW), suggesting idiosyncratic drug induced liver injury in most cases. Some cases, reported in patients who previously experienced liver injury during treatment with other immunomodulatory therapies used to treat multiple sclerosis, were suggestive of autoimmune hepatitis. Most events resolved with discontinuation of treatment and a relationship to Copaxone could not be excluded (see **ADVERSE REACTIONS, Post-Market Adverse Reactions**).

Caution is recommended when considering treatment with Copaxone in patients who have pre-existing liver disease or who have experienced liver injury previously during treatment with other drugs, including other disease modifying therapies (DMTs) for treatment of multiple sclerosis or with concomitant (DILI) risk drugs.

Prior to initiating treatment with COPAXONE, serum aminotransferase, alkaline phosphatase and total bilirubin levels should be obtained (within 6 months) for all patients. Patients should be monitored during treatment for signs of hepatic injury. Evaluation of transaminases is recommended during treatment, as clinically relevant (see **WARNINGS AND PRECAUTIONS, Monitoring and Laboratory Tests**). Patients should be advised to immediately report any signs or symptoms of hepatotoxicity (e.g., jaundice, dark urine, abdominal pain, nausea, vomiting, loss of appetite, weight loss, unusual fatigue). Discontinue treatment if clinically significant liver injury induced by COPAXONE is suspected.

Immune

Considerations Involving the Use of a Product Capable of Modifying Immune Responses:

COPAXONE is an antigenic substance and thus it is possible that detrimental host responses can occur with its use. Whether COPAXONE can alter normal human immune responses, such as the recognition of foreign antigens is unknown. It is therefore possible that treatment with COPAXONE may undermine the body's defenses against infections and tumor surveillance. Systematic assessments of these risks have not been done. Continued alteration of cellular immunity due to chronic treatment with glatiramer acetate might result in untoward effects.

Glatiramer acetate-reactive antibodies are formed in practically all patients exposed to treatment with the recommended dose. Studies in both the rat and monkey have suggested that immune complexes are deposited in the renal glomeruli. Furthermore, in a controlled clinical trial of 125 RRMS patients given glatiramer acetate 20 mg for 2 years, serum IgG levels reached at least 3 times baseline values in 80% of patients by 3 months of initiation of treatment. By 12 months of treatment, however, 30% of patients still had IgG levels at least 3 times baseline values, and 90% had levels above baseline by 12 months. The antibodies are exclusively of the IgG subtype - and predominantly of the IgG-1 subtype. No IgE type antibodies could be detected in any of the 94 sera tested.

Nevertheless, anaphylaxis can be associated with the administration of almost any foreign substance and, therefore, this risk cannot be excluded.

COPAXONE has not been studied in patients with a history of severe anaphylactoid reactions, obstructive pulmonary disease or asthma, nor in patients under treatment for either of these two latter conditions. Particular caution is therefore advised regarding the use of COPAXONE in such patients.

Anaphylactoid reactions associated with the use of COPAXONE have been reported in rare instances (<1/1000) during the post-marketing period. Some cases required treatment with epinephrine and other appropriate medical treatment.

Monitoring and Laboratory Tests

Renal

The pharmacokinetics of COPAXONE in patients with impaired renal function have not been determined. In patients with renal impairment, renal function should be monitored while they are treated with COPAXONE. While there is no evidence of glomerular deposition of immune complexes in patients, the possibility cannot be excluded.

Liver function

Liver transaminases should be checked (within 6 months) before initiating treatment with COPAXONE. Evaluation of transaminases is recommended during treatment, as clinically relevant (see WARNINGS AND PRECAUTIONS, Hepatic; ADVERSE REACTIONS, Postmarket Adverse Reactions).

6.1 Special Populations

6.1.1 Pregnant Women

There are no adequate and well-controlled studies in pregnant women. No evidence of reproductive toxicity was observed in preclinical studies (see **NON-CLINICAL TOXICOLOGY: Reproduction and Teratology**). The potential risk for humans is not fully known (See **ADVERSE REACTIONS, Post-Market Adverse Reactions**). However, since animal reproduction studies are not always predictive of human response and there are no adequate and well controlled studies in pregnant women with MS, COPAXONE should be used during pregnancy only when, in the judgment of the physician, the potential benefits outweigh the possible hazards.

During pre-marketing clinical trials with COPAXONE (20 mg/mL once per day), seven women conceived while being treated with the active drug. One case was lost to follow-up. Three of the patients electively discontinued pregnancy. Three patients stopped treatment 1, 1.5 and 2 months after learning they were pregnant; all delivered healthy babies. In a 12-month placebo-controlled trial with COPAXONE (40 mg/mL three times per week) a total of nine pregnancies were reported. Of these, one patient experienced a spontaneous abortion at 13 weeks gestation and three patients had elective abortions. Five pregnancies were carried to term and all delivered healthy babies. Patients stopped treatment with COPAXONE prior to or upon learning that they were pregnant.

6.1.2 Breast-feeding

It is not known whether COPAXONE is excreted in human milk. Because many drugs are excreted in human milk, caution should be exercised when COPAXONE is administered to a nursing woman. No significant effects on offspring growth and development were observed in preclinical studies (see **NON-CLINICAL TOXICOLOGY: Reproduction and Teratology**).

6.1.3 Pediatrics

Pediatrics (under 18 years of age): No data are available to Health Canada; therefore, Health Canada has not authorized an indication for pediatric use.

6.1.4 Geriatrics

Geriatrics (over 65 years of age): No data are available to Health Canada; therefore, Health Canada has not authorized an indication for geriatric use.

7 ADVERSE REACTIONS

Most Copaxone safety data were accumulated for COPAXONE 20 mg/mL administered as a subcutaneous injection once daily. This section presents accumulated safety data from 4

placebo-controlled trials with COPAXONE 20 mg/mL administered once daily, and from one placebo-controlled trial with COPAXONE 40 mg/mL administered three times a week.

COPAXONE 20 mg/mL (administered once daily)

7.1 Adverse Reaction Overview

In 4 placebo-controlled clinical trials, the most commonly observed adverse events associated with the use of COPAXONE occurring at an incidence of at least 10% and at least 1.5 times higher than in placebo treated patients were: injection site reactions, vasodilatation, rash, dyspnea and chest pain.

In the placebo-controlled clinical trials approximately 5% discontinued treatment due to an adverse event compared to 1% for placebo treated patients. The adverse events most commonly associated with discontinuation were (in order of descending frequency): injection site reactions, dyspnea, urticaria, vasodilatation and hypersensitivity. Treatment discontinuation due to a serious adverse event considered by investigators to be related to COPAXONE treatment included a case of life-threatening serum sickness.

Immediate Post-Injection Reaction: Approximately 14% of Multiple Sclerosis patients exposed to COPAXONE in 4 placebo-controlled studies reported a post-injection reaction immediately following subcutaneous injection of COPAXONE compared to 2% for placebo treated patients. An immediate post-injection reaction is a constellation of symptoms occurring immediately after injection that includes at least two of the following: flushing, chest pain, palpitations, anxiety, dyspnea, constriction of the throat and urticaria (individual symptoms are listed separately in Table 1 below). These symptoms were invariably transient, self-limited, did not require specific treatment and in general, arose several months after initiation of treatment, although they may occur earlier in the course of treatment. A given patient may experience one or several episodes of these symptoms during treatment with COPAXONE. Whether these episodes are mediated by an immunologic or non-immunologic mechanism, and whether several similar episodes seen in a given patient have identical mechanisms is unknown. In fact, whether or not this constellation of symptoms actually represents a specific syndrome is unknown. During the post-marketing period, there have been reports of patients with similar symptoms who received emergency medical care (see **WARNINGS AND PRECAUTIONS, Cardiovascular, Symptoms of Potentially Cardiac Origin**).

Chest Pain: Approximately 13% of glatiramer acetate patients in 4 placebo-controlled studies (compared to 5% of placebo patients) experienced at least one episode of what was described as transient chest pain. While some of these episodes occurred in the context of the Immediate Post-Injection Reaction described above, many did not. The temporal relationship of the chest pain to an injection of glatiramer acetate was not always known, although the pain was transient (usually lasting only a few minutes), often unassociated with other symptoms, and appeared to have no important clinical sequelae. Some patients experienced more than one such episode, and episodes usually began at least 1 month after the initiation of treatment. The pathogenesis of this symptom is unknown. Patients in clinical trials were free of significant cardiovascular disease (New York Heart Association Class I or II); therefore, the risks associated with glatiramer acetate treatment for Multiple Sclerosis patients with comorbid cardiovascular disease are unknown (see **WARNINGS AND PRECAUTIONS, Cardiovascular, Symptoms of Potentially Cardiac Origin**).

7.2 Clinical Trial Adverse Reactions

Because clinical trials are conducted under very specific conditions the adverse reaction rates observed in the clinical trials may not reflect the rates observed in practice and should not be compared to the rates in the clinical trials of another drug. Adverse drug reaction information from clinical trials is useful for identifying drug-related adverse events and for approximating rates.

COPAXONE 20 mg/mL (administered once daily)

The adverse reaction data in this section is derived from 4 pivotal, double-blind, placebo-controlled clinical trials which were conducted during pre-marketing and post-marketing periods in a total of 512 patients treated with glatiramer acetate and 509 patients treated with placebo for up to 36 months. Three trials were conducted in RRMS. The fourth trial was in patients presenting with a first clinical event and MRI features suggestive of MS and included 243 patients treated with glatiramer acetate and 238 patients treated with placebo.

All adverse events were recorded by the clinical investigators, using terminology of their own choosing. To provide a meaningful estimate of the proportion of individuals having adverse events, similar types of events were grouped into standardized categories using MedDRA dictionary terminology.

The following table lists treatment-emergent signs and symptoms that occurred in at least 2% of patients treated with glatiramer acetate in the placebo-controlled trials. These signs and symptoms were numerically more common in patients treated with glatiramer acetate than in patients treated with placebo. Lipoatrophy occurred in approximately 2% of patients exposed to COPAXONE 20 mg/mL once per day in the multicentre controlled trials (compared to none on placebo).

Table 2: Controlled Trials (COPAXONE 20 mg/mL per day): Incidence of Glatiramer Acetate Adverse Reactions $\geq 2\%$ and More Frequent than Placebo

MedDRA Version 10.0		GA 20 mg (N=512)	Placebo (N=509)
		% of Patients	% of Patients
Blood And Lymphatic System Disorders	Lymphadenopathy	7.2	2.9
Cardiac Disorders	Palpitations	7.6	3.3
	Tachycardia	4.7	1.6
Eye Disorders	Eye Disorder	3.3	1.2
	Diplopia	2.9	1.8
Gastrointestinal Disorders	Nausea	14.5	10.4
	Vomiting	7.4	4.3
	Constipation	7.0	6.3
	Dyspepsia	6.6	6.5
	Dysphagia	2.3	1.2
	Faecal Incontinence	2.3	2.0
General Disorders And Administration Site Conditions	Injection Site Erythema	46.1	10.6
	Injection Site Pain	36.3	17.1
	Injection Site Mass	25.8	5.9
	Injection Site Pruritus	24.4	2.8
	Asthenia	23.8	23.2
	Injection Site Edema	20.9	4.5
	Pain	18.9	16.7
	Chest Pain	12.5	4.9
	Injection Site Inflammation	8.2	1.6
	Injection Site Reaction	8.2	1.4
	Pyrexia	6.4	5.7
	Injection Site Hypersensitivity	4.1	0.0
	Local Reaction	3.7	1.4
	Face Edema	3.3	0.6
	Edema Peripheral	3.3	2.4
	Chills	2.9	0.4
	Injection Site Atrophy*	2.0	0.0
	Injection Site Fibrosis	2.0	0.6
	Immune System Disorders	Hypersensitivity	3.3

MedDRA Version 10.0		GA 20 mg (N=512)	Placebo (N=509)
		% of Patients	% of Patients
Infections And Infestations	Infection	31.8	30.8
	Influenza	15.4	14.5
	Rhinitis	7.4	5.9
	Bronchitis	6.4	5.7
	Gastroenteritis	6.3	4.3
	Vaginal Candidiasis	4.9	2.6
	Otitis Media	3.7	2.9
	Herpes Simplex	2.5	1.8
	Tooth Abscess	2.3	2.2
Metabolism And Nutrition Disorders	Weight Increased	2.9	0.8
	Anorexia	2.3	2.2
Musculoskeletal And Connective Tissue Disorders	Back Pain	13.5	11.2
	Arthralgia	10.4	9.4
	Neck Pain	4.5	3.9
Nervous System Disorders	Headache	30.9	29.1
	Hypertonia	7.8	7.3
	Tremor	4.1	1.8
	Migraine	3.7	2.4
	Syncope	3.1	1.8
Psychiatric Disorders	Depression	13.1	12.0
	Anxiety	11.1	8.8
	Nervousness	2.3	1.0
Renal And Urinary Disorders	Micturition Urgency	5.1	4.3
	Pollakiuria	4.7	4.5
Respiratory, Thoracic And Mediastinal Disorders	Dyspnoea	13.3	2.8
	Cough	6.6	5.3
Skin And Subcutaneous Tissue Disorders	Rash	13.7	9.0
	Hyperhidrosis	6.6	4.7
	Pruritus	5.1	4.3
	Ecchymosis	3.5	3.3
	Urticaria	3.1	1.6
	Skin Disorder	2.9	0.8
Vascular Disorders	Vasodilatation**	18.0	4.7

* "Injection site atrophy" comprises terms relating to localized lipoatrophy at injection site

** "Vasodilatation" includes the terms "feeling hot", "flushing", "hot flush", "hyperaemia" and "vasodilatation".

In the fourth trial noted above, an open-label treatment phase followed the placebo-controlled period. No new safety signals were observed during the open-label follow-up period of up to 5 years.

Data on adverse events occurring in the 4 controlled clinical trials were analyzed to evaluate sex-related differences. No clinically significant differences were identified. In these clinical trials 96% of patients were Caucasian. This percentage reflects the higher representation of

Caucasian in the MS population, even though it does not reflect the exact world racial distribution among MS patients. In addition, the vast majority of patients treated with COPAXONE were between the ages of 18 and 45. Consequently, inadequate data are available to perform an analysis of the incidence of adverse events related to clinically relevant age subgroups.

COPAXONE 40 mg/mL (administered three times per week)

The safety of COPAXONE 40 mg/mL was assessed based on a double-blind, placebo-controlled clinical trial in RRMS patients with a total of 943 patients treated for 12 months with COPAXONE 40 mg/mL three times per week, and 461 patients treated with placebo. Among the 943 patients treated with COPAXONE 40 mg/mL, approximately 3% of the subjects discontinued treatment because of an adverse event. The most common adverse events were injection site reactions, which were also the most common cause of discontinuation.

No new adverse events were seen in patients treated with COPAXONE 40 mg/mL administered three times per week as compared to subjects treated with COPAXONE 20 mg/mL administered daily.

Injection site reactions were reported by 36% of the patients on COPAXONE 40 mg/mL compared to 5% on placebo. Immediate post-injection reaction was reported by approximately 2% of the patients on COPAXONE 40 mg/mL compared to none on placebo. Approximately 2% of patients exposed to COPAXONE 40 mg/mL three times per week in single placebo-controlled trial (compared to 1% of placebo patients) experienced at least one episode of what was described as transient chest pain.

Table 3 lists treatment-emergent AEs that occurred in at least 2% of patients treated with COPAXONE 40 mg/mL three times per week in the blinded, placebo-controlled trial. These AEs were numerically more common in patients treated with COPAXONE 40 mg/mL than in patients treated with placebo. Adverse events were usually mild in intensity.

Table 3: Controlled Trial (COPAXONE 40 mg/mL three times per week): Incidence of Glatiramer Acetate Adverse Events $\geq 2\%$ and More Frequent than Placebo

MedDRA Version 15.0		GA 40 mg (N=943)	Placebo (N=461)
		% of Patients	% of Patients
Gastrointestinal Disorders	Nausea	2.3	1.3
General Disorders and Administration Site Conditions	Injection Site Erythema	20.9	1.5
	Injection Site Pain	10.4	2.0
	Injection Site Pruritus	5.9	0.0
	Injection Site Swelling	4.0	0.4
	Influenza Like Illness	3.2	1.5
	Injection Site Induration	3.1	0.0
	Pyrexia	2.4	1.3
	Chills	2.0	0.0
Infections and Infestations	Nasopharyngitis	10.6	8.5
	Influenza	3.8	3.7
	Respiratory Tract Infection Viral	2.5	1.5
	Pharyngitis	2.0	1.1
Musculoskeletal and Connective Tissue Disorders	Pain in Extremity	2.1	1.7
Respiratory, Thoracic and Mediastinal Disorders	Dyspnea	3.2	0.4

Data on adverse events occurring in the controlled clinical trial were analyzed to evaluate differences based on sex. Injection site reactions, mainly erythema, pain and pruritus occurred with a higher incidence ($\geq 5\%$) in females (13.7%) than males (8.1%) in patients treated with COPAXONE 40 mg/mL three times per week; the majority of patients in this trial were female (68%).

7.3 Other Clinical Trial Adverse Reactions

COPAXONE 20 mg/mL (administered once daily)

In the pre-marketing clinical trials, approximately 900 individuals received at least one dose of COPAXONE (glatiramer acetate) in controlled and uncontrolled clinical trials. Total patient exposure to COPAXONE in these clinical trials ranged from 6 months (693 patients) to 2 years (306 patients), with a subset of patients continuing to 20 years (n=63) in an open-label extension at a daily dose of 20 mg.

During these trials, all adverse events were recorded by clinical investigators using terminology of their own choosing. To provide a meaningful estimate of the proportion of individuals having adverse events, similar types of events were grouped into a smaller number of standardized categories using COSTART II dictionary terminology. All reported events that occurred at least twice and potentially important events occurring once, are included except those already listed in the previous table, those too general to be informative, trivial events, and other events which occurred in at least 2% of treated patients and were present at equal or greater rates in the placebo group.

Events are further classified within body system categories and enumerated in order of decreasing frequency using the following definitions: *Frequent* adverse events are defined as those occurring in at least 1/100 patients; *infrequent* adverse events are those occurring in 1/100 to 1/1000 patients.

Body as a whole:

Frequent. Injection site edema, injection site atrophy, abscess and injection site hypersensitivity.

Infrequent. Injection site hematoma, injection site fibrosis, moon face, cellulitis, generalized edema, hernia, injection site abscess, serum sickness, suicide attempt, injection site hypertrophy, injection site melanosis, lipoma, and photosensitivity reaction.

Cardiovascular:

Frequent. Hypertension.

Infrequent. Hypotension, midsystolic click, systolic murmur, atrial fibrillation, bradycardia, fourth heart sound, postural hypotension and varicose veins.

Digestive:

Frequent. Liver function abnormality

Infrequent. Dry mouth, stomatitis, burning sensation on tongue, cholecystitis, colitis, esophageal ulcer, esophagitis, gastrointestinal carcinoma, gum hemorrhage, hepatomegaly, increased appetite, melena, mouth ulceration, pancreas disorder, pancreatitis, rectal hemorrhage, tenesmus, tongue discoloration and duodenal ulcer.

Endocrine:

Infrequent. Goiter, hyperthyroidism, and hypothyroidism.

Gastrointestinal:

Frequent: Bowel urgency, oral moniliasis, salivary gland enlargement, tooth caries, and ulcerative stomatitis.

Hemic and Lymphatic:

Infrequent: Leukopenia, anemia, cyanosis, eosinophilia, hematemesis, lymphedema, pancytopenia, and splenomegaly.

Metabolic and Nutritional:

Infrequent: Weight loss, alcohol intolerance, Cushing's syndrome, gout, abnormal healing, and xanthoma.

Musculoskeletal:

Infrequent: Arthritis, muscle atrophy, bone pain, bursitis, kidney pain, muscle disorder, myopathy, osteomyelitis, tendon pain, and tenosynovitis.

Nervous:

Frequent: Abnormal dreams, emotional lability and stupor.

Infrequent: Aphasia, ataxia, convulsion, circumoral paresthesia, depersonalization, hallucinations, hostility, hypokinesia, coma, concentration disorder, facial paralysis, decreased libido, manic reaction, memory impairment, myoclonus, neuralgia, paranoid reaction, paraplegia, psychotic depression and transient stupor.

Respiratory:

Frequent: Hyperventilation, hay-fever.

Infrequent: Asthma, pneumonia, epistaxis, hypoventilation, and voice alteration.

Skin and Appendages:

Frequent: Eczema, herpes zoster, pustular rash, skin atrophy and warts.

Infrequent: Dry skin, skin hypertrophy, dermatitis, furunculosis, psoriasis, angioedema, contact dermatitis, erythema nodosum, fungal dermatitis, maculopapular rash, pigmentation, benign skin neoplasm, skin carcinoma, skin striae, and vesiculobullous rash.

Special Senses:

Frequent: Visual field defect.

Infrequent: Dry eyes, otitis externa, ptosis, cataract, corneal ulcer, mydriasis, optic neuritis, photophobia, and taste loss.

Urogenital:

Frequent: Amenorrhea, hematuria, impotence, menorrhagia, suspicious Papanicolaou smear, urinary frequency and vaginal hemorrhage.

Infrequent: Vaginitis, flank pain (kidney), abortion, breast engorgement, breast enlargement, breast pain, carcinoma cervix *in situ*, fibrocystic breast, kidney calculus, nocturia, ovarian cyst, priapism, pyelonephritis, abnormal sexual function, and urethritis.

In the post-marketing clinical trials, more than 5500 individuals were exposed to glatiramer acetate (20 mg/day) as part of the clinical development program. Safety data collected in these trials have shown an adverse event profile similar to that presented above.

COPAXONE 40 mg/mL (administered three times per week)

The following is a list of adverse events reported by COPAXONE-treated patients at an incidence rate of less than 2% and $\geq 0.3\%$ higher than placebo, and including potentially important events that occurred at least once in the double-blind phase and open-label extension of the clinical trial. Events that were already included in Table 2 have been excluded. Although the events reported occurred during treatment with COPAXONE, they were not necessarily caused by COPAXONE.

Events are listed by body system in decreasing order of incidence in COPAXONE-treated patients.

Blood and Lymphatic System Disorders: lymphadenopathy (0.6%)

Cardiac Disorders: tachycardia (1.2%), palpitations (1%)

Ear and Labyrinth Disorders: tinnitus (0.3%)

Eye Disorders: vision blurred (0.3%)

Gastrointestinal Disorders: abdominal pain (1.2%), vomiting (0.7%), gastroesophageal reflux disease (0.4%), pancreatitis (0.3%)

General Disorders and Administration Site Conditions: injection site oedema (1.8%), injection site mass (1.7%), asthenia (1.6%), injection site inflammation (1.6%), injection site extravasation (1.5%), injection site reaction (1.5%), feeling hot (1.3%), injection site rash (1.1%), chest pain (0.8%), injection site haematoma (0.7%), injection site hypertrophy (0.7%), oedema peripheral (0.7%), chest discomfort (0.5%), injection site atrophy (0.4%), injection site irritation (0.4%), pain (0.4%), spinal pain (0.4%), discomfort (0.3%), hyperthermia (0.3%), injection site anaesthesia (0.3%), localised oedema (0.3%)

Hepatobiliary Disorders: hepatic steatosis (0.2%), drug-induced liver injury (0.1%), hepatitis toxic (0.1%)

Immune System Disorders: drug hypersensitivity (0.3%), anaphylactic reaction (0.2%), anaphylactic shock (0.1%)

Infections and Infestations: cystitis (1.7%), viral infection (0.8%), gastroenteritis viral (0.6%), oral herpes (0.5%), pyelonephritis chronic (0.5%), vulvovaginal mycotic infection (0.4%), herpes simplex (0.3%), papilloma viral infection (0.3%), pneumonia (0.3%), vaginitis bacterial (0.3%)

Injury, Poisoning and Procedural Complications: fall (0.8%), limb injury (0.3%), thermal burn (0.3%)

Investigations: weight decreased (0.7%), neutrophil count decreased (0.3%), red blood cell count decreased (0.3%)

Metabolism and Nutrition Disorders: hypercholesterolaemia (0.3%)

Musculoskeletal and Connective Tissue Disorders: myalgia (0.5%), musculoskeletal chest pain (0.4%), arthritis (0.3%), osteopenia (0.3%)

Neoplasms Benign, Malignant and Unspecified (including Cysts and Polyps): fibroadenoma of the breast (0.1%), intraductal papilloma of breast (0.1%)*, invasive ductal breast carcinoma (0.1%)*, breast neoplasm (0.1%)*

Nervous System Disorders: paraesthesia (1.4%), syncope (1%), trigeminal neuralgia (0.4%), tremor (0.3%)

Renal and Urinary Disorders: leukocyturia (1.1%), haematuria (0.6%)

Reproductive System and Breast Disorders: breast disorder (0.1%), breast discharge (0.1%), menstrual disorder (0.4%), breast calcifications (0.1%)*, breast dysplasia (0.1%)*

Respiratory, Thoracic and Mediastinal Disorders: cough (1.8%)

Skin and Subcutaneous Tissue Disorders: erythema (1.8%), hyperhidrosis (0.5%), skin reaction (0.5%), angioedema (0.4%), acne (0.3%), generalised erythema (0.3%), lipoatrophy (0.1%)

Surgical and Medical Procedures: mastectomy (0.1%)*

Vascular Disorders: flushing (1.0%), hypotension (0.7%), hyperaemia (0.6%), hot flush (0.3%)

*Events occurred during the open-label extension of the clinical trial

7.4 Abnormal Laboratory Findings: Hematologic, Clinical Chemistry and Other Quantitative Data

Laboratory analyses were performed on all patients participating in the clinical program for COPAXONE. Clinically significant changes in laboratory values for hematology, chemistry, and urinalysis were similar for both COPAXONE and placebo groups in blinded clinical trials. No patient receiving COPAXONE withdrew from any placebo-controlled trial due to abnormal laboratory findings which were assessed as possibly related to glatiramer acetate.

7.5 Post-Market Adverse Reactions

Adverse Events Reported Post-Marketing and Not Previously Noted in Clinical Trials

Post-marketing experience has shown an adverse event profile similar to that presented above. Reports of adverse reactions occurring under treatment with COPAXONE in clinical trials or from spontaneous reports that have been received since market introduction and that may have or not have causal relationship to the drug, include the following:

Body as a Whole:

Sepsis, SLE syndrome, hydrocephalus, enlarged abdomen, injection site hypersensitivity, allergic reaction, anaphylactoid reaction, bacterial infection, fever, infection.

Cardiovascular:

Thrombosis, peripheral vascular disease, pericardial effusion, myocardial infarct, deep thrombophlebitis, coronary occlusion, congestive heart failure, cardiomyopathy, cardiomegaly, arrhythmia, angina pectoris, tachycardia.

Digestive:

Tongue edema, stomach ulcer hemorrhage, liver damage, hepatitis, eructation, cirrhosis of the liver, cholelithiasis, diarrhea, gastrointestinal disorder.

Hemic and Lymphatic:

Thrombocytopenia, lymphoma-like reaction, acute leukemia.

Metabolic and Nutritional:

Hypercholesteremia.

Musculoskeletal:

Rheumatoid arthritis, generalized spasm.

Nervous:

Myelitis, meningitis, CNS neoplasm, cerebrovascular accident, brain edema, abnormal dreams, aphasia, convulsion, neuralgia, anxiety, foot drop, nervousness, speech disorder, vertigo.

Respiratory:

Pulmonary embolus, pleural effusion, carcinoma of lung, hay fever, laryngismus.

Skin and Appendages:

Herpes simplex, pruritis, rash, urticaria.

Special Senses:

Glaucoma, blindness, visual field defect.

Urogenital:

Urogenital neoplasm, urine abnormality, ovarian carcinoma, nephrosis, kidney failure, breast carcinoma, bladder carcinoma, urinary frequency.

Post-market safety analysis demonstrated that the safety profile of COPAXONE 40 mg/mL (administered three times per week) is compatible with the safety profile of COPAXONE 20 mg/mL (administered once daily).

Localized Adverse Reactions Associated with Subcutaneous Use

At injection sites, localized lipoatrophy and, rarely, injection site skin necrosis have been reported during post-marketing experience. Lipoatrophy may occur after treatment onset (sometimes as early as several months) and may be permanent. There is no known therapy for lipoatrophy. To assist in possibly minimizing these events the patient should be advised to follow proper injection technique and to rotate injection areas and sites on a regular basis (see **Part III – Patient Medication Information**).

To date, post-market information was received on more than 2,000 prospectively reported pregnancies with known outcome in patients exposed to conventional dose regimens of COPAXONE. In this cohort, the reported rates of fetal loss and congenital anomalies or disorders were found to be within the range found in a normal pregnant population, indicating no malformative or fetoneonatal toxicity of COPAXONE. However, since there are no adequate and well controlled studies in pregnant women with MS, COPAXONE should be used during pregnancy only if clearly needed.

Severe Liver Injury

Very rare cases of severe liver injury (including liver failure, hepatitis with jaundice, fulminant hepatitis leading to liver transplant) have been reported with Copaxone. Most instances of severe liver injury resolved with discontinuation of treatment and a relationship to Copaxone

could not be excluded (see **WARNINGS AND PRECAUTIONS, Hepatic; WARNINGS AND PRECAUTIONS, Monitoring and Laboratory Tests**).

8 DRUG INTERACTIONS

8.1 Overview

Interactions between COPAXONE and other drugs have not been fully evaluated. Results from existing clinical trials do not suggest any significant interactions of COPAXONE with therapies commonly used in MS patients. This includes the concurrent use of corticosteroids for up to 28 days.

9 ACTION AND CLINICAL PHARMACOLOGY

9.1 Mechanism of action

COPAXONE (glatiramer acetate) is a sterile, lyophilized mixture of synthetic polypeptides containing four naturally occurring amino acids: L-glutamic acid, L-alanine, L-tyrosine and L-lysine with an average molar fraction of 0.141, 0.427, 0.095 and 0.338, respectively.

The precise mechanism by which glatiramer acetate exerts therapeutic effects in MS patients is not fully elucidated, but may involve immunomodulation by inducing a regulatory phenotype of antigen presenting cells (e.g., dendritic cells, monocytes, and B cells), which may exert direct effects and/or support regulatory and anti-inflammatory T cell populations.

Because the immunological profile of glatiramer acetate remains to be fully elucidated, concerns exist about its potential to alter naturally occurring immune responses, but this has not been systematically evaluated (see **WARNINGS AND PRECAUTIONS: Immune**).

9.2 Pharmacokinetics

Results obtained in pharmacokinetic studies performed in humans (healthy volunteers) and animals support the assumption that a substantial fraction of the therapeutic dose delivered to patients subcutaneously is hydrolyzed locally. Nevertheless, larger fragments of glatiramer acetate can be recognized by glatiramer acetate reactive antibodies. Some fraction of the injected material, either intact or partially hydrolyzed, is presumed to enter the lymphatic circulation, enabling it to reach regional lymph nodes, and some, may enter the systemic circulation intact.

10 STORAGE, STABILITY AND DISPOSAL

The pre-filled syringes of COPAXONE should be refrigerated immediately upon receipt (2°-8°C). DO NOT FREEZE.

COPAXONE prefilled syringes contain no preservative. Do not use if the solution contains any particulate matter.

If you cannot have refrigerator storage, pre-filled syringes of COPAXONE can be stored at room temperature (15° - 30°C) for up to 1 month. Do not store pre-filled syringes at room temperature for longer than 1 month. Note: this drug is light sensitive, do not expose to light when not injecting. Each pre-filled syringe is for single use only.

Throw out all used syringes in a hard-walled plastic container.

PART II: SCIENTIFIC INFORMATION

11 PHARMACEUTICAL INFORMATION

Drug Substance

- Proper name: Glatiramer acetate
- Chemical name: Glatiramer acetate is the acetate salt of synthetic polypeptides.
- Description: Glatiramer acetate is prepared by chemically reacting the activated derivatives of four amino acids: L-glutamic acid (L-Glu), L-alanine (L-Ala), L-tyrosine (L-Tyr), and L-lysine (L-Lys) in a specified ratio. The average molar fraction of each amino acid residue are as follows: L-Glu 0.141, L-Ala 0.427, L-Tyr 0.095 and L-Lys 0.338.
- Molecular formula and molecular mass: The average molecular weight of glatiramer acetate is 5,000 to 9,000 daltons. Glatiramer acetate is identified by specific antibodies.
- Structural formula: $\text{Poly}[\text{L-Glu}^{13-15}, \text{L-Ala}^{39-46}, \text{L-Tyr}^{8,6-10}, \text{L-Lys}^{30-37}] \bullet n\text{CH}_3\text{CO}_2\text{H}$ (n=15-24)
- Physical form: White to slightly yellowish lyophilized material.
- Solubility: Sparingly soluble in water, insoluble in acetone.
- pH: The pH of a 0.5% w/v solution of glatiramer acetate in water is in the range of 5.5 to 7.0.
- Biological activity: The biological activity of COPAXONE is determined by its ability to block the induction of experimental autoimmune encephalomyelitis (EAE) in mice.

12 CLINICAL TRIALS

COPAXONE 20 mg/mL (administered once daily)

The efficacy of COPAXONE (glatiramer acetate) was evaluated in two placebo-controlled trials in patients with Relapsing Remitting MS (RRMS). In a third placebo-controlled study the effects of glatiramer acetate on MRI parameters were assessed.

The first trial was a pilot study (BR-1) which was conducted at a single-center and was a double-blind, randomized, matched-pair, parallel group placebo-controlled trial. Fifty patients with RRMS were randomized to receive 20 mg/day glatiramer acetate (n=25) or placebo (n=25) subcutaneously. The protocol-specified primary outcome measure was the proportion of patients who were relapse free during the 2-year duration of the trial, but two additional relevant outcomes were also specified as endpoints: frequency of attacks during the trial, and the change in the number of attacks compared to the rate of attacks in the 2 years prior to study entry. Results from this study (see Table 4) show that there was a statistically significant effect of glatiramer acetate on number of relapses.

Table 4- Trial BR-1: Efficacy Results

Outcome^a	Glatiramer acetate n=25	Placebo n=25	p-Value
% Relapse Free Patients	14/25 (56%)	7/25 (28%)	0.085
Mean Relapse Frequency	0.6/2 years	2.4/2 years	0.005
Reduction in Relapse Rate compared to pre-study	3.2	1.6	0.025
Median Time to First Relapse (days)	>700	150	0.03
% of Progression-Free* Patients	20/25 (80%)	13/25 (52%)	0.07

^aThe primary efficacy measure was the proportion of patients who were relapse free during the 2 year duration of the trial (% **Relapse Free**). Analyses were based on the intent-to-treat population.

* Progression defined as an increase of at least 1 point on the DSS that persists for at least 3 consecutive months.

The second study (01-9001) was a multicenter double-blind, randomized, placebo-controlled trial. Two hundred and fifty-one patients with RRMS were randomized to receive 20 mg/day glatiramer acetate (n=125) or placebo (n=126) subcutaneously. Patients were diagnosed with RRMS by Poser criteria, and had at least 2 exacerbations during the 2 years immediately preceding enrollment. Patients had a score of no more than 5 on the Kurtzke Expanded Disability Scale Score (EDSS), a standard scale ranging from 0 (normal) to 10 (death due to MS). A score of 5 is defined as one at which a patient is still ambulatory but for whom full daily activities are impaired due to disability, a score of 6 is defined as one at which the patient is still ambulatory but requires assistance and a score of 7 on this scale means that the patient requires a wheelchair.

Patients were seen every 3 months for 2 years, as well as within several days of a presumed exacerbation. In order for an exacerbation to be confirmed, a blinded neurologist had to document objective neurologic signs, as well as document the existence of other criteria (e.g., the persistence of the lesion for at least 48 hours).

The protocol-specified primary outcome measure was the mean number of relapses during treatment.

Table 5 shows results of the analysis of primary as well as several secondary outcome measures at two years based on the intent-to-treat population.

Table 5 – Trial 01-9001: Core (24-month) Double-Blind Study: Effect on Relapse Rate

Outcome ^a	Glatiramer acetate n=125	Placebo n=126	p-Value
Mean No of Relapses/2 years ^b	1.19	1.68	0.007*
% Relapse Free Patients	42/125 (34%)	34/126 (27%)	0.25
Median Time to First Relapse (days)	287	198	0.23
% of Patients Progression Free ^c	98/125 (78%)	95/126 (75%)	0.48
Mean Change in EDSS	-0.05	+0.21	0.023

^a The primary efficacy measure was the number of relapses during treatment. Analyses were based on the intent-to-treat population.

^b Baseline adjusted mean

^c Progression defined as an increase of at least 1 point on the EDSS that persists for at least 3 consecutive months.

* Analysis of Covariance adjusted for baseline EDSS, prior 2-year relapse rate and study centers. ANCOVA or analysis of covariance is a statistical test used to adjust for covariate differences between the treatment and control groups which may confound the true treatment effect when one or more factors are not balanced across treatment groups.

The effects of glatiramer acetate on relapse severity were not evaluated in either trial.

Both studies showed a beneficial effect of glatiramer acetate on relapse rate, and on this basis glatiramer acetate is considered effective.

The third study (9003) was a multi-national, multi-center, MRI-monitored study. A total of 239 patients with RRMS (119 on glatiramer acetate and 120 on placebo) were randomized. Inclusion criteria were similar to those in Study 01-9001 with the additional criteria that patients had to have at least one Gd-enhancing lesion on the screening MRI. The patients were treated initially in a double-blind manner for nine months, during which they underwent monthly MRI scanning. The primary endpoint for the double-blind phase was the total cumulative number of T1 Gd-enhancing lesions over nine months. Other MRI parameters were assessed as secondary endpoints. Table 6 summarizes the results for the parameters monitored during the nine-month double-blind phase for the intent-to-treat cohort. Because the link between MRI findings and the clinical status of patients is contentious, the prognostic value of the following statistically significant findings is unknown.

Table 6 – Trial 9003: Nine-Month Double-Blind Phase: MRI Endpoints - Results

No.	Outcome	Glatiramer Acetate (n=113)	Placebo (n=115)	p-value
Primary Endpoint				
1	Medians of the Cumulative Number of T1 Gd-Enhancing Lesions	12	17	0.0037
Secondary Endpoints				
2	Medians of the Cumulative Number of New T1 Gd-Enhancing Lesions	9	14	0.0347
3	Medians of the Cumulative Number of New T2 Lesions	5	8	0.01
4	Medians of the Cumulative Change from Baseline in volumes (mL) of T1 Gd-Enhancing Lesions	-0.309	0	0.0248
5	Medians of the Cumulative Change from Baseline in volumes (mL) of T2 Lesions	8.852	13.566	0.0229
6.	Medians of the Cumulative Change from Baseline in volumes (mL) of T1 Hypointense Lesions	1.642	1.829	0.7311
	Proportion of T1 Gd-Enhancing Lesion-Free Patients	46.4%	32.2%	0.0653

The mean number of relapses in this 9 month study was 0.50 for the COPAXONE® group and 0.77 for the placebo group (p = 0.0077).

Patients with early RRMS

A fourth study (GA/9010) was a multicenter, randomized, double-blind, placebo-controlled, parallel group study involving 481 patients for up to three years (glatiramer acetate 20 mg/day: n=243; placebo: n=238). It was performed in patients with a well-defined, single, unifocal neurological presentation and with at least two cerebral lesions on T2-weighted MRI (previously referred to as "clinically isolated syndrome"). The primary outcome measure in the study was the time to development of a second exacerbation according to Poser criteria. Secondary outcomes were brain MRI measures including number of new T2 lesions and T2 lesion volume.

Time to development of a second exacerbation was significantly delayed in the glatiramer acetate group corresponding to a risk reduction of 45% (Hazard Ratio = 0.55; 95% CI [0.40; 0.77], p=0.0005) (Figure 1).

Figure 1: Trial GA/9010: Time to Second Exacerbation (ITT Analysis)

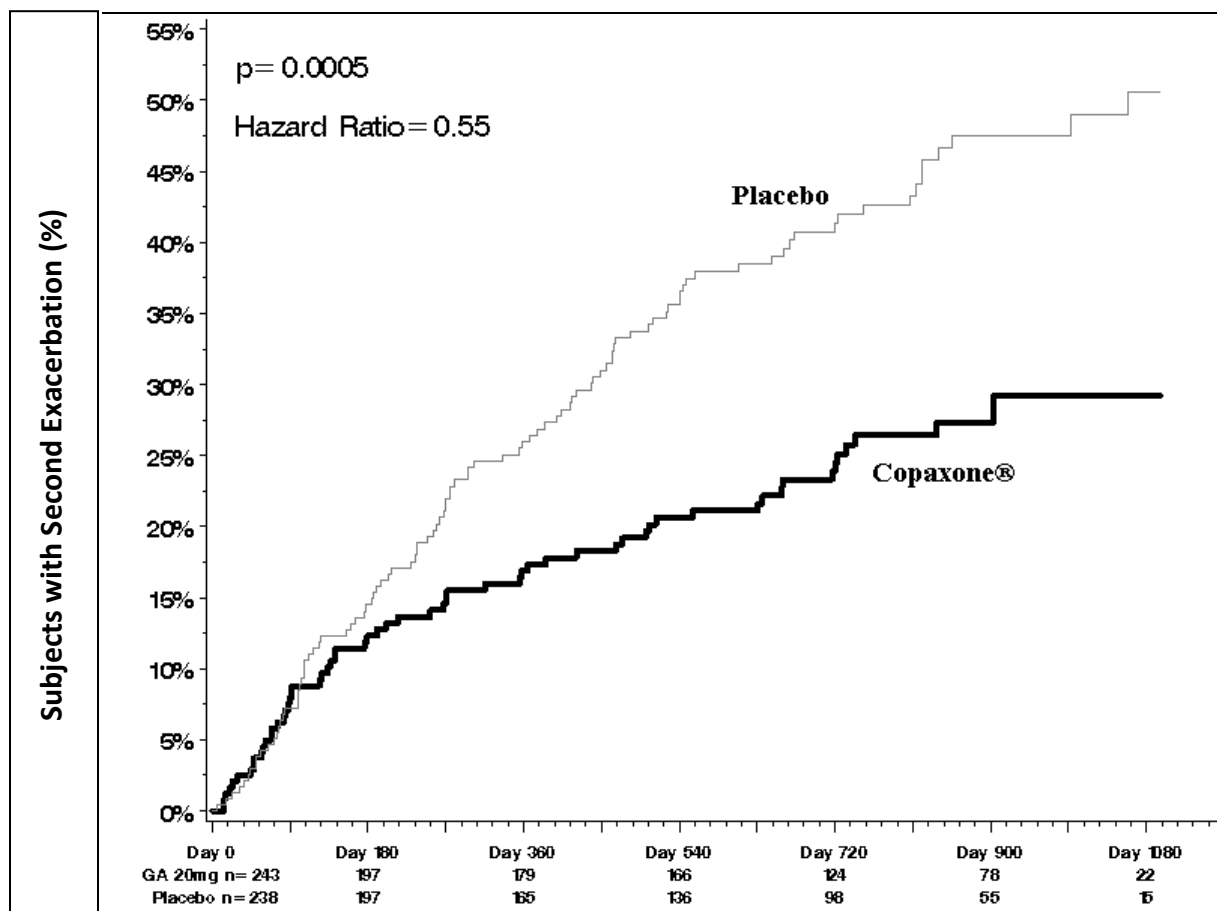

Glatiramer acetate prolonged the time to second exacerbation by 386 (115%) days, from 336 days in the placebo group to 722 days in the glatiramer acetate group (based on the 25th percentile; Kaplan-Meier estimates).

A total of 25% of glatiramer acetate patients, and 43% of placebo patients experienced a second exacerbation in an average duration of treatment of 2.4 years.

The benefit of treatment with glatiramer acetate over placebo was also demonstrated in two secondary MRI-based endpoints. The number of new T2 lesions at last observed value (LOV) was significantly lower ($p < 0.0001$) for patients on glatiramer acetate, demonstrating a treatment effect of 58% for glatiramer acetate over placebo (mean number of new T2 lesions at LOV was 0.7 for glatiramer acetate and 1.8 for placebo). Additionally, baseline-adjusted T2 lesion volume at LOV showed a significant reduction ($p = 0.0013$) of 13% for glatiramer acetate over placebo (median change in T2 volume from baseline to LOV was 0.7 mL on glatiramer acetate and 1.3 mL on placebo).

However, the impact of early treatment with COPAXONE 20 mg/mL once-daily on the long term evolution of the disease is unknown as the study was mainly designed to assess the time to the second exacerbation event.

COPAXONE 40 mg/mL (administered three times per week)

Study MS-GA-301 was a double-blind, placebo-controlled, multinational trial with a total of 1404 patients with RRMS randomized in a 2:1 ratio to receive either COPAXONE 40 mg/mL (n=943) or placebo (n=461) three times a week for 12 months. Patients had a median of 2 relapses in the 2 years prior to screening and had not received any interferon-beta for at least 2 months prior to screening. Baseline EDSS scores ranged from 0 to 5.5 with a median of 2.5. Neurological evaluations were performed at baseline, every three months, and at unscheduled visits for suspected relapse or early termination. MRI was performed at baseline, months 6 and 12, or early termination. A total of 91% of those assigned to COPAXONE and 93% of those assigned to placebo completed treatment at 12 months.

The primary outcome measure was the total number of confirmed relapses (persistence of neurological symptoms for at least 48 hours confirmed on examination with objective signs). The effect of COPAXONE on several magnetic resonance imaging (MRI) variables, including number of new or enlarging T2 lesions and number of enhancing lesions on T1-weighted images, was also measured at months 6 and 12. See Table 7.

Table 7 – Study MS-GA-301: Efficacy and MRI Results in the ITT population

	COPAXONE 40 mg/mL (n=943)	Placebo (n=461)	P-Value
Clinical Endpoints			
Number of confirmed relapses during the 12-month placebo-controlled phase			
Adjusted Mean Estimates	0.331	0.505	<0.0001
Relative risk reduction	34%		
MRI Endpoints			
Cumulative number of new or enlarging T2 lesions at Months 6 and 12			
Adjusted Mean Estimates	3.650	5.592	<0.0001
Relative risk reduction	35%		
Cumulative number of enhancing lesions on T1-weighted images at Months 6 and 12			
Adjusted Mean Estimates	0.905	1.639	<0.0001
Relative risk reduction	45%		

13 PHARMACOLOGY

Glatiramer acetate is efficacious in suppressing and/or preventing both the clinical and histological manifestations of the most widely accepted animal model of Multiple Sclerosis, EAE. This effect of glatiramer acetate has been demonstrated in a wide variety of species including mice, rats, guinea pigs, rabbits, and primates (rhesus monkeys and baboons).¹⁻⁸

Glatiramer acetate partially cross-reacts with myelin basic protein (MBP) on both the humoral and cellular levels. In addition, it competes with myelin-associated peptides including myelin oligodendrocyte glycoprotein (MOG) and proteolipid protein (PLP) for binding to the MHC class II molecules.⁹ Glatiramer acetate binds with high affinity to MHC Class II molecules on the surface of antigen presenting cells.¹⁰ *In vitro* studies demonstrate that the affinity of glatiramer acetate is sufficient to competitively displace MBP, MOG and PLP from MHC II.⁹ Specificity of glatiramer acetate binding is demonstrated by the observation that anti-MHC II DR antibodies but not anti-MHC I or anti-MHC II DQ antibodies inhibit interaction of glatiramer acetate with MHC II.⁹

Induction of suppressor T-cells has been demonstrated experimentally. T-cell hybridomas established from spleen cells of glatiramer acetate treated animals were shown to adoptively transfer resistance to EAE in untreated animals and to inhibit antigen-specific proliferation and interleukin-2 (IL-2) secretion of an MBP-specific T-cell line.¹¹ Inhibition of MBP-specific effector T-cells by glatiramer acetate has been demonstrated in several *in vitro* studies. In the presence of antigen presenting cells, glatiramer acetate competitively inhibits proliferation and IL-2 and interferon gamma secretion by human MBP-specific T-cell lines while having no effect on T-cell lines specific for other antigens. Glatiramer acetate alone does not stimulate proliferation,^{12,13} IL-2 secretion^{12,13} or cytotoxic responses in human MBP-specific T-cells¹⁴. In addition, glatiramer acetate has been shown to inhibit MBP-specific T-cell cytotoxicity.¹⁴

Attempts have been made to characterize bioavailability using subcutaneously administered ¹²⁵I-Glatiramer acetate in animals. Serum samples were qualitatively analyzed by HPLC to estimate the proportion of intact glatiramer acetate and glatiramer acetate-related peptide fragments over time. The HPLC elution pattern was consistent with that for glatiramer acetate three minutes after injection. By 15 minutes, the elution pattern shifted to two distinct smaller species and free iodide. It is unclear if the smaller species represented ¹²⁵I-Glatiramer acetate metabolites or other unrelated species iodinated as a result of iodide exchange. These studies have not been repeated in man.

Other *in vitro* and *in vivo* studies in animals demonstrate that ¹²⁵I-Glatiramer acetate is rapidly degraded at the site of injection. Tissue homogenate studies suggest this may also be true in man. Due to the possibility of de-iodination, iodide exchange and incorporation of amino acids from glatiramer acetate into other peptides, results from these studies with ¹²⁵I-Glatiramer acetate must be cautiously interpreted.

14 NON-CLINICAL TOXICOLOGY

Acute Toxicity

Glatiramer acetate was well tolerated following a single subcutaneous injection at a dose of 400 mg/kg in the rat. No toxic effects were noted.

After intravenous administration of 200 mg/kg in the rat, severe morbidities with about 10% mortalities were recorded. At 40 mg/kg, no mortalities occurred and only transient tremor was noted in one animal.

Long-Term Toxicity (Subchronic and Chronic)

Toxicity and reproductive studies were performed with glatiramer acetate involving 560 rats treated for up to 6 months, 68 rabbits treated for up to 2 weeks, 23 dogs treated for up to 3 months and 32 monkeys treated for up to 1 year. The several deaths that occurred (5 rats in the 6-month study, 2 rats in the 4-week study, 1 rat in the segment III reproduction study and 1 monkey in the 1-year study) were judged as incidental and unrelated to treatment.

Chronic and subchronic daily subcutaneous injections were systemically well tolerated at doses of up to 30 mg/kg/day for periods extending for up to 6 months in the rat and up to one year in the monkey.

In aging male rats (at the end of the life-span carcinogenicity study), there was a small increase in the incidence of glomerulonephritis. The NOAEL for this finding was 7.5 mg/kg/day.

At doses of 30 mg/kg and above some findings such as slight reduction in body weight gain, and occasional minor changes in blood chemistry and hematological parameters were noted. These findings were noted in some studies and not in others, and were without any clinical sequelae. No remarkable findings were noted in ophthalmoscopic or in EKG evaluations. In monkeys treated with 30 mg/kg/day there were some evidence for over immune stimulations such as an increase in the titer of antinuclear antibodies, an increase in the incidence of germinal centers in the bone marrow and of minor chronic focal fibrosing arterial lesions. The association of these findings to treatment is uncertain and the NOAEL for these findings was set to 10 mg/kg/day.

Based on these findings, the NOAEL for the systemic effects of glatiramer acetate in chronic studies is considered to be 7.5 mg/kg.

Local lesions at the injection sites were consistently observed in all studies and were dose related. At doses of 30 mg/kg/day and above in the rat and the monkey, injection site reactions were clinically significant and poorly tolerated.

Carcinogenicity

Two life-span carcinogenicity studies with glatiramer acetate, one in mice and one in rats, were completed. Results from the two carcinogenicity studies do not suggest any evidence of carcinogenic potential related to glatiramer acetate administered subcutaneously to rats and mice, at dose levels of up to 60 mg/kg/day.

In the two-year carcinogenicity study in the mouse, repeated administration of doses up to 60 mg/kg/day, showed no evidence for systemic carcinogenicity. In males of the high dose group (60 mg/kg/day), but not in females, there was an increased incidence of fibrosarcomas at

the injection sites. These rapidly growing sarcomas, consisting of spindle or fusiform cells with local invasion but no metastasis, were associated with skin damage precipitated by repetitive injections of an irritant over a limited skin area.

In a two-year carcinogenicity study in rats, subcutaneous administration of glatiramer acetate at a dose of 30 mg/kg/day was associated with an increased incidence of benign adrenal pheochromocytomas in males only. This effect was not seen at 15 mg/kg/day and was within the historical control values for the testing laboratory.

Mutagenicity

Glatiramer acetate showed a marginal and inconsistent effect on structural chromosomal aberrations in cultured human lymphocytes. Chromosomal aberrations or abnormalities did not occur in bone marrow cells of mice given 140 mg/kg, equivalent to approximately 60% of the LD₅₀/kg, i.p. Glatiramer acetate, with or without metabolic activation, did not induce point mutations in four strains of *Salmonella typhimurium*, two strains of *Escherichia coli*, or mouse lymphoma L5178Y cell cultures.

Reproduction and Teratology

In fertility and reproduction studies in rats, glatiramer acetate at doses up to 36 mg/kg/day had no adverse effects on reproductive parameters.

Embryofetal development toxicity studies have been performed in rats and rabbits at doses up to approximately 37.5 mg/kg and have revealed no evidence of impaired development of the fetus due to glatiramer acetate.

Peri- and post-natal development toxicity studies did not reveal any effect on the development and reproductive performances of pups born to female rats that were dosed until weaning of the pups with glatiramer acetate at doses up to 36 mg/kg.

Antigenicity Studies

Studies to assess anaphylaxis in sensitized guinea pigs and mice showed that glatiramer acetate elicited IgG activity but very low or no IgE activity.

Cardiac Study

In a dog study, a pharmacological effect of intravenous glatiramer acetate, i.e. reduction of blood pressure, was achieved at a dose of 6.0 mg/kg (10-times the human therapeutic dose on a mg/m² basis) but not at a 2-fold lower dose. This was not associated with a decrease in coronary artery blood flow or ischemic change on ECG.

READ THIS FOR SAFE AND EFFECTIVE USE OF YOUR MEDICINE

PATIENT MEDICATION INFORMATION

COPAXONE® glatiramer acetate injection

Read this carefully before you start taking **COPAXONE** and each time you get a refill. This leaflet is a summary and will not tell you everything about this drug. Talk to your healthcare professional about your medical condition and treatment and ask if there is any new information about **COPAXONE**.

What is COPAXONE used for?

COPAXONE 20 mg/mL (once-daily) is used to treat patients with Relapsing Remitting Multiple Sclerosis (RRMS), including those who have experienced one episode of nervous system symptoms and who have abnormalities on their brain scan that may be the first signs of Multiple Sclerosis.

COPAXONE 40 mg/mL (three times-a-week) is used to treat patients with Relapsing Remitting Multiple Sclerosis (RRMS).

COPAXONE is not a cure. Patients treated with COPAXONE experience fewer relapses (flare-ups of the disease).

How does COPAXONE work?

Multiple Sclerosis (MS) is thought to be a disease where your immune system causes your body to attack its own cells. This leads to loss of myelin, a substance that covers your nerve fibers. The loss of myelin eventually leads to the symptoms of MS.

COPAXONE is a mixture of small proteins. These small proteins are similar to a protein found in myelin. COPAXONE is thought to work by modifying the immune processes that are believed to cause MS.

What are the ingredients in COPAXONE?

Medicinal ingredients: Glatiramer acetate

Non-medicinal ingredients: Mannitol in sterile water for injection

COPAXONE comes in the following dosage forms:

Once-daily solution: 20 mg/1 mL pre-filled syringe.

Three times-a-week solution: 40 mg/1 mL pre-filled syringe.

Do not use COPAXONE if:

- you are allergic to glatiramer or mannitol.
- the solution in the pre-filled syringe is cloudy, leaking or contains any particles.

To help avoid side effects and ensure proper use, talk to your healthcare professional before you take COPAXONE. Talk about any health conditions or problems you may have, including if you:

- have heart disease. Some patients taking COPAXONE experience chest pain.
- have a history of developing severe allergic reactions.
- have chronic obstructive pulmonary disease (COPD).
- have asthma.
- have kidney and or liver problems.
- are pregnant, planning to become pregnant, or if you become pregnant while you are using this medication.
- are nursing.
- are under 18 years of age.

Tell your healthcare professional about all the medicines you take, including any drugs, vitamins, minerals, natural supplements or alternative medicines.

How to take COPAXONE:

The **first** time you use COPAXONE you:

- will be given full instructions on how to use it.
- should be supervised by a doctor or nurse.

Each pre-filled syringe should be:

- used only once.
- used only for subcutaneous injection.

Usual Adult Dose:

- **COPAXONE 20 mg/1 mL** is injected once a day.
- **COPAXONE 40 mg/1 mL** is injected 3 times each week on the same 3 days each week, if possible (for example, Monday, Wednesday and Friday). The injections are given at least 48 hours (2 days) apart.

Your doctor will prescribe the correct dose for you. Do **NOT** change the dose or dosing schedule without consulting your doctor.

Do **NOT** stop using COPAXONE without consulting your doctor.

COPAXONE 20 mg/mL (once-daily) and COPAXONE 40 mg/mL (three times-a-week) are not interchangeable because they are different in their strength and dosing schedule.

INSTRUCTIONS FOR USE

Step 1: Gathering the materials

- Collect one of each of the items you will need on a clean, flat surface in a well-lit area.
 - 1 COPAXONE pre-filled syringe. (Each syringe is contained inside a protective blister. Holding the package of syringes, tear off only 1 blister at a time. Keep all unused syringes in the refrigerator.)
 - Alcohol swab (not supplied) or access to soap and water
 - Dry cotton ball (not supplied)
- Ensure that the solution is at room temperature. Let the unopened blister containing the syringe stand at room temperature for at least 20 minutes.
- **Before you inject** wash and dry your hands. Avoid touching your hair or skin, after you have washed your hands. This will help prevent infection.
- Do **NOT** try to force small air bubbles out of the syringe before injecting the medicine.

Step 2: Choosing the site for injection

You should have a planned schedule for your chosen injection sites and make note of it in a diary.

- There are **7** possible areas on your body for injection (**see Figure 1**):
 - back of upper arms (right and left)
 - front and outside of thighs (right and left)
 - upper buttocks/rear of hips (right and left)
 - stomach (abdomen)
- If you are taking **COPAXONE 20 mg/1 mL (once-daily)**, pick a different area each day (one for each day of the week).
- If you are taking **COPAXONE 40 mg/1 mL (three times-a-week)**, pick each injection area only once per week.
- Within each of the 7 areas there are many sites where you can inject the drug. Rotate the injection sites within the chosen area. **Choose a different injection site each time.**

Figure 1:

Arms Administer the injection in the upper back portion of the arm.	Stomach Administer the injection leaving 5 cm (2 inches) around the navel
---	---

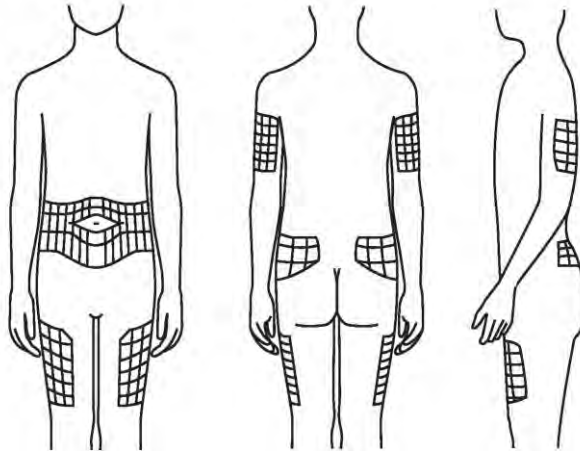

Buttocks Administer the injection in the upper and outer rear quadrant.	Thighs Administer the injection in the front and outer part of the thigh, 5 cm (2 inches) above the knee and 5 cm (2 inches) below the groin.
---	---

- **Please note:** do NOT inject in any area that is:
 - painful.
 - discoloured.
 - where you feel firm knots or lumps.
 - where skin depression has occurred (a “dent” at the injection site). Further injections in these sites may make the depression deeper.

Hard to inject areas: There may be some areas on your body that may be hard for you to inject the drug yourself (such as the back of your arms). You should ask your doctor or nurse for instructions on how to inject COPAXONE in these areas.

Step 3: Injection

1. Remove the syringe from its protective blister by peeling back the paper label. Place the syringe back on the clean, flat surface.

2. Clean the site you have chosen to inject by using:
 - a fresh alcohol swab. (Let it air dry for 1 minute to reduce any stinging.)
 - or
 - soap and water
3. Using the hand you write with, pick up the syringe as you would a pencil. Remove the needle cap from the needle.
4. With your other hand, pinch about a 5 centimeter (2 inch) fold of skin between your thumb and index finger (**See Figure 2**).
5. While resting the heel of your hand against your body, **insert** the needle at a 90° angle. When the needle is all the way in the skin, let go the fold of skin (**See Figure 3**).

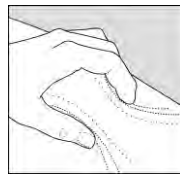

Figure 2

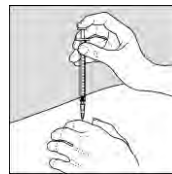

Figure 3

6. To inject the medication, hold the syringe steady and push down on the plunger. This should take only a few seconds. (**See Figure 3**)
7. Pull the needle straight out.
8. Press a dry cotton ball on the injection site for few seconds.
9. Throw out the syringe and the needle cap in a safe hard-walled plastic container.

Proper disposal of needles:

- Throw out all used syringes in a hard-walled plastic container (such as a Sharps container from a pharmacy).
- Keep the cover of this container closed tight and **out of the reach and sight of children**.
- When the container is full, check with your doctor, pharmacist or nurse about proper disposal.

Overdose:

If you think you have taken too much COPAXONE, contact your healthcare professional, hospital emergency department or regional Poison Control Centre immediately, even if there are no symptoms.

Missed Dose:

COPAXONE 20 mg/mL (once daily): If you miss a dose, you should take it as soon as you remember. If it is less than 12 hours before your next dose, skip the missed dose and take your next dose at the usual time. Do NOT give yourself 2 injections in the same 12-hour period.

COPAXONE 40 mg/mL (three times-a-week): If you miss a dose, you should take it as soon as you remember. If it is less than 48 hours before your next dose, skip the missed dose and take your next dose at the usual time. Do NOT give yourself 2 injections in the same 48-hour period.

What are possible side effects from using COPAXONE?

These are not all the possible side effects you may feel when taking COPAXONE. If you experience any side effects not listed here, contact your healthcare professional.

The most common side effects of COPAXONE are:

- Skin reactions at the injection site. These include:
 - Redness
 - Pain
 - Inflammation
 - Itching
 - Swelling
 - Lumps
- A permanent “dent” under the skin at the injection site, caused by damage to the fatty tissue at that site.
- Rash
- Hives
- Headache
- A feeling of worry, nervousness, unease (anxiety)

Serious side effects and what to do about them			
Symptom / effect	Talk to your healthcare professional		Stop taking drug and get immediate medical help
	Only if severe	In all cases	
COMMON Post-injection Reaction: Flushing, dizziness, skin eruptions with irritation, sweating, chest pain, chest tightness, irregular heartbeat, anxiety, difficulty in breathing, tightness in the throat, hives appearing immediately after injection			√
Low blood pressure: dizziness, fatigue, nausea		√	
High blood pressure: headache, dizziness, blurred vision or shortness of breath		√	
Breathing problems: shortness of breath, difficulty breathing		√	
Fast heart beat or skipping a beat		√	
Chest pain: pressure or tightness in the chest		√	
Back, neck or joint pain	√		
Angioedema: Swelling of the arms, legs or face	√		
Depression: change in weight, difficulty sleeping, lack of interest in regular activities	√		
Changes to your vision	√		
RARE Serious Allergic Reactions: rash, hives, swelling of the face, lips, throat, difficulty swallowing or breathing			√
VERY RARE Liver injury: Yellowing of the skin or eyes, dark urine, abdominal pain, nausea, vomiting, loss of appetite, weight loss, unusual tiredness.			√

If you have a troublesome symptom or side effect that is not listed here or becomes bad enough to interfere with your daily activities, talk to your healthcare professional.

Reporting Side Effects

You can report any suspected side effects associated with the use of health products to Health Canada by:

- Visiting the Web page on Adverse Reaction Reporting (<http://www.hc-sc.gc.ca/dhp-mps/medeff/report-declaration/index-eng.php>) for information on how to report online, by mail or by fax; or
- Calling toll-free at 1-866-234-2345.

NOTE: Contact your health professional if you need information about how to manage your side effects. The Canada Vigilance Program does not provide medical advice.

Storage:

- Refrigerate (2° - 8°C) immediately. Do NOT FREEZE
- If you cannot store COPAXONE in the refrigerator, it can be stored for 1 month at room temperature (15° - 30°C). Do NOT store for longer than 1 month at room temperature.
- Protect from light. This drug is sensitive to light.

Keep out of reach and sight of children.

If you want more information about COPAXONE:

- Talk to your healthcare professional
- Find the full product monograph that is prepared for healthcare professionals and includes this Patient Medication Information by visiting the Health Canada website (www.healthcanada.gc.ca), the manufacturer's website (<http://www.tevacanadainnovation.ca>), or by calling 1-800-283-0034.

This leaflet was prepared by Teva Canada Innovation.

Last revised: June 5, 2020.

HIGHLIGHTS OF PRESCRIBING INFORMATION

These highlights do not include all the information needed to use COPAXONE® safely and effectively. See full prescribing information for COPAXONE.

COPAXONE (glatiramer acetate injection), for subcutaneous use
Initial U.S. Approval: 1996

RECENT MAJOR CHANGES

Indications and Usage (1) 7/2019
Warnings and Precautions, Hepatic Injury (5.5) 7/2020

INDICATIONS AND USAGE

COPAXONE is indicated for the treatment of relapsing forms of multiple sclerosis (MS), to include clinically isolated syndrome, relapsing-remitting disease, and active secondary progressive disease, in adults (1).

DOSAGE AND ADMINISTRATION

- For subcutaneous injection only; doses are not interchangeable (2.1)
- COPAXONE 20 mg/mL per day (2.1)
- COPAXONE 40 mg/mL three times per week (2.1)
- Before use, allow the solution to warm to room temperature (2.2)

DOSAGE FORMS AND STRENGTHS

- Injection: 20 mg/mL in a single-dose prefilled syringe with a white plunger (3)
- Injection: 40 mg/mL in a single-dose, prefilled syringe with a blue plunger (3)

CONTRAINDICATIONS

Known hypersensitivity to glatiramer acetate or mannitol (4)

WARNINGS AND PRECAUTIONS

- Immediate Post-Injection Reaction (flushing, chest pain, palpitations, tachycardia, anxiety, dyspnea, throat constriction, and/or urticaria), may occur within seconds to minutes after injection and are generally transient and self-limiting (5.1)
- Chest pain, usually transient (5.2)
- Lipoatrophy and skin necrosis may occur. Instruct patients in proper injection technique and to rotate injection sites (5.3)
- COPAXONE can modify immune response (5.4)
- Hepatic Injury: if signs or symptoms of hepatic dysfunction occur, consider discontinuing COPAXONE (5.5)

ADVERSE REACTIONS

- In controlled studies of COPAXONE 20 mg/mL, most common adverse reactions ($\geq 10\%$ and ≥ 1.5 times higher than placebo) were: injection site reactions, vasodilatation, rash, dyspnea, and chest pain (6.1)
- In a controlled study of COPAXONE 40 mg/mL, most common adverse reactions ($\geq 10\%$ and ≥ 1.5 times higher than placebo) were: injection site reactions (6.1)

To report SUSPECTED ADVERSE REACTIONS, contact Teva Pharmaceuticals at 1-888-483-8279 or FDA at 1-800-FDA-1088 or www.fda.gov/medwatch.

See 17 for PATIENT COUNSELING INFORMATION and FDA-approved patient labeling.

Revised: 7/2020

FULL PRESCRIBING INFORMATION: CONTENTS*

1	INDICATIONS AND USAGE
2	DOSAGE AND ADMINISTRATION
2.1	Recommended Dose
2.2	Instructions for Use
3	DOSAGE FORMS AND STRENGTHS
4	CONTRAINDICATIONS
5	WARNINGS AND PRECAUTIONS
5.1	Immediate Post-Injection Reaction
5.2	Chest Pain
5.3	Lipoatrophy and Skin Necrosis
5.4	Potential Effects on Immune Response
5.5	Hepatic Injury
6	ADVERSE REACTIONS
6.1	Clinical Trials Experience
6.2	Postmarketing Experience
7	DRUG INTERACTIONS
8	USE IN SPECIFIC POPULATIONS

8.1	Pregnancy
8.2	Lactation
8.4	Pediatric Use
8.5	Geriatric Use
8.6	Use in Patients with Impaired Renal Function
11	DESCRIPTION
12	CLINICAL PHARMACOLOGY
12.1	Mechanism of Action
12.3	Pharmacokinetics
13	NONCLINICAL TOXICOLOGY
13.1	Carcinogenesis, Mutagenesis, Impairment of Fertility
14	CLINICAL STUDIES
16	HOW SUPPLIED/STORAGE AND HANDLING
17	PATIENT COUNSELING INFORMATION

*Sections or subsections omitted from the full prescribing information are not listed.

FULL PRESCRIBING INFORMATION

1 INDICATIONS AND USAGE

COPAXONE is indicated for the treatment of relapsing forms of multiple sclerosis (MS), to include clinically isolated syndrome, relapsing-remitting disease, and active secondary progressive disease, in adults.

2 DOSAGE AND ADMINISTRATION

2.1 Recommended Dose

COPAXONE is for subcutaneous use only. Do not administer intravenously. The dosing schedule depends on the product strength that is selected. The recommended doses are:

- COPAXONE 20 mg per mL: administer once per day
or
- COPAXONE 40 mg per mL: administer three times per week and at least 48 hours apart

COPAXONE 20 mg per mL and COPAXONE 40 mg per mL are not interchangeable.

2.2 Instructions for Use

Remove one blister-packaged prefilled syringe from the refrigerated carton. Let the prefilled syringe stand at room temperature for 20 minutes to allow the solution to warm to room temperature. Visually inspect the syringe for particulate matter and discoloration prior to administration. The solution in the syringe should appear clear, colorless to slightly yellow. If particulate matter or discoloration is observed, discard the syringe.

Areas for subcutaneous self-injection include arms, abdomen, hips, and thighs. The prefilled syringe is for single use only. Discard unused portions.

3 DOSAGE FORMS AND STRENGTHS

- Injection: 20 mg per mL in a single-dose, prefilled syringe with a white plunger. For subcutaneous use only.
- Injection: 40 mg per mL in a single-dose, prefilled syringe with a blue plunger. For subcutaneous use only.

4 CONTRAINDICATIONS

COPAXONE is contraindicated in patients with known hypersensitivity to glatiramer acetate or mannitol.

5 WARNINGS AND PRECAUTIONS

5.1 Immediate Post-Injection Reaction

Approximately 16% of patients exposed to COPAXONE 20 mg per mL in the 5 placebo-controlled trials compared to 4% of those on placebo, and approximately 2% of patients exposed to COPAXONE 40 mg per mL in a placebo-controlled trial compared to none on placebo, experienced a constellation of symptoms that may occur immediately (within seconds to minutes, with the majority of symptoms observed within 1 hour) after injection and included at least two of the following: flushing, chest pain, palpitations, tachycardia, anxiety, dyspnea, constriction of the throat, and urticaria. In general, these symptoms have their onset several months after the initiation of treatment, although they may occur earlier, and a given patient may experience one or several episodes of these symptoms. Whether or not any of these symptoms actually represent a specific syndrome is uncertain. Typically, the symptoms were transient and self-limited and did not require treatment; however, there have been reports of patients with similar symptoms who received emergency medical care. Whether an immunologic or nonimmunologic mechanism mediates these episodes, or whether several similar episodes seen in a given patient have identical mechanisms, is unknown.

5.2 Chest Pain

Approximately 13% of COPAXONE 20 mg per mL patients in the 5 placebo-controlled studies compared to 6% of placebo patients, and approximately 2% of patients exposed to COPAXONE 40 mg per mL in a placebo-controlled trial compared to 1% of placebo patients, experienced at least one episode of transient chest pain. While some of these episodes occurred in the context of the Immediate Post-Injection Reaction described above, many did not. The temporal relationship of this chest pain to an injection was not always known. The pain was usually transient, often unassociated with other symptoms, and appeared to have no clinical sequelae. Some patients experienced more than one such episode, and episodes usually began at least 1 month after the initiation of treatment. The pathogenesis of this symptom is unknown.

5.3 Lipoatrophy and Skin Necrosis

At injection sites, localized lipoatrophy and, rarely, injection site skin necrosis may occur. Lipoatrophy occurred in approximately 2% of patients exposed to COPAXONE 20 mg per mL in the 5 placebo-controlled trials compared to none on placebo, and 0.5% of patients exposed to COPAXONE 40 mg per mL in a single placebo-controlled trial and none on placebo. Skin necrosis has only been observed in the postmarketing setting. Lipoatrophy may occur at various times after treatment onset (sometimes after several months) and is thought to be permanent. There is no known therapy for lipoatrophy. To assist in possibly minimizing these events, the patient should be advised to follow proper injection technique and to rotate injection sites with each injection.

5.4 Potential Effects on Immune Response

Because COPAXONE can modify immune response, it may interfere with immune functions. For example, treatment with COPAXONE may interfere with the recognition of foreign antigens in a way that would undermine the body's tumor surveillance and its defenses against infection.

There is no evidence that COPAXONE does this, but there has not been a systematic evaluation of this risk. Because COPAXONE is an antigenic material, it is possible that its use may lead to the induction of host responses that are untoward, but systematic surveillance for these effects has not been undertaken.

Although COPAXONE is intended to minimize the autoimmune response to myelin, there is the possibility that continued alteration of cellular immunity due to chronic treatment with COPAXONE may result in untoward effects.

Glatiramer acetate-reactive antibodies are formed in most patients receiving glatiramer acetate. Studies in both the rat and monkey have suggested that immune complexes are deposited in the renal glomeruli. Furthermore, in a controlled trial of 125 RRMS patients given COPAXONE 20 mg per mL, subcutaneously every day for 2 years, serum IgG levels reached at least 3 times baseline values in 80% of patients by 3 months of initiation of treatment. By 12 months of treatment, however, 30% of patients still had IgG levels at least 3 times baseline values, and 90% had levels above baseline by 12 months. The antibodies are exclusively of the IgG subtype and predominantly of the IgG-1 subtype. No IgE type antibodies could be detected in any of the 94 sera tested; nevertheless, anaphylaxis can be associated with the administration of most any foreign substance, and therefore, this risk cannot be excluded.

5.5 Hepatic Injury

Cases of hepatic injury, some severe, including liver failure and hepatitis with jaundice, have been reported with COPAXONE. Hepatic injury has occurred from days to years after initiating treatment with COPAXONE. If signs or symptoms of liver dysfunction occur, consider discontinuation of COPAXONE.

6 ADVERSE REACTIONS

The following serious adverse reactions are described elsewhere in the labeling:

- Immediate Post-Injection Reaction [*see Warnings and Precautions (5.1)*]
- Chest Pain [*see Warnings and Precautions (5.2)*]
- Lipatrophy and Skin Necrosis [*see Warnings and Precautions (5.3)*]
- Potential Effects on Immune Response [*see Warnings and Precautions (5.4)*]
- Hepatic Injury [*see Warnings and Precautions (5.5)*]

6.1 Clinical Trials Experience

Because clinical trials are conducted under widely varying conditions, adverse reaction rates observed in the clinical trials of a drug cannot be directly compared to rates in the clinical trials of another drug and may not reflect the rates observed in practice.

Incidence in Controlled Clinical Trials

COPAXONE 20 mg per mL per day

Among 563 patients treated with COPAXONE in blinded placebo-controlled trials, approximately 5% of the subjects discontinued treatment because of an adverse reaction. The adverse reactions most commonly associated with discontinuation were: injection site reactions,

dyspnea, urticaria, vasodilatation, and hypersensitivity. The most common adverse reactions were: injection site reactions, vasodilatation, rash, dyspnea, and chest pain.

Table 1 lists signs and symptoms that occurred in at least 2% of patients treated with COPAXONE 20 mg per mL in the placebo-controlled trials. These signs and symptoms were numerically more common in patients treated with COPAXONE than in patients treated with placebo. Adverse reactions were usually mild in intensity.

Table 1: Adverse Reactions in Controlled Clinical Trials with an Incidence \geq 2% of Patients and More Frequent with COPAXONE (20 mg per mL Daily) than with Placebo

		COPAXONE 20 mg/mL (n=563) %	Placebo (n=564) %
Blood And Lymphatic System Disorders	Lymphadenopathy	7	3
Cardiac Disorders	Palpitations	9	4
	Tachycardia	5	2
Eye Disorders	Eye Disorder	3	1
	Diplopia	3	2
Gastrointestinal Disorders	Nausea	15	11
	Vomiting	7	4
	Dysphagia	2	1
General Disorders And Administration Site Conditions	Injection Site Erythema	43	10

		COPAXONE 20 mg/mL (n=563) %	Placebo (n=564) %
	Injection Site Pain	40	20
	Injection Site Pruritus	27	4
	Injection Site Mass	26	6
	Asthenia	22	21
	Pain	20	17
	Injection Site Edema	19	4
	Chest Pain	13	6
	Injection Site Inflammation	9	1
	Edema	8	2
	Injection Site Reaction	8	1
	Pyrexia	6	5
	Injection Site Hypersensitivity	4	0
	Local Reaction	3	1
	Chills	3	1
	Face Edema	3	1
	Edema Peripheral	3	2
	Injection Site Fibrosis	2	1
	Injection Site Atrophy*	2	0
Immune System Disorders	Hypersensitivity	3	2
Infections And Infestations	Infection	30	28
	Influenza	14	13
	Rhinitis	7	5
	Bronchitis	6	5
	Gastroenteritis	6	4
	Vaginal Candidiasis	4	2
Metabolism And Nutrition Disorders	Weight Increased	3	1
Musculoskeletal And Connective Tissue Disorders	Back Pain	12	10
Neoplasms Benign, Malignant And Unspecified (Incl Cysts And Polyps)	Benign Neoplasm of Skin	2	1
Nervous System Disorders	Tremor	4	2

		COPAXONE 20 mg/mL (n=563) %	Placebo (n=564) %
	Migraine	4	2
	Syncope	3	2
	Speech Disorder	2	1
Psychiatric Disorders	Anxiety	13	10
	Nervousness	2	1
Renal And Urinary Disorders	Micturition Urgency	5	4
Respiratory, Thoracic And Mediastinal Disorders	Dyspnea	14	4
	Cough	6	5
	Laryngospasm	2	1
Skin And Subcutaneous Tissue Disorders	Rash	19	11
	Hyperhidrosis	7	5
	Pruritus	5	4
	Urticaria	3	1
	Skin Disorder	3	1
Vascular Disorders	Vasodilatation	20	5

*Injection site atrophy comprises terms relating to localized lipoatrophy at injection site

Adverse reactions which occurred only in 4 to 5 more subjects in the COPAXONE group than in the placebo group (less than 1% difference), but for which a relationship to COPAXONE could not be excluded, were arthralgia and herpes simplex.

Laboratory analyses were performed on all patients participating in the clinical program for COPAXONE. Clinically-significant laboratory values for hematology, chemistry, and urinalysis were similar for both COPAXONE and placebo groups in blinded clinical trials. In controlled trials one patient discontinued treatment due to thrombocytopenia ($16 \times 10^9/L$), which resolved after discontinuation of treatment.

Data on adverse reactions occurring in the controlled clinical trials of COPAXONE 20 mg per mL were analyzed to evaluate differences based on sex. No clinically-significant differences were identified. Ninety-six percent of patients in these clinical trials were Caucasian. The majority of patients treated with COPAXONE were between the ages of 18 and 45. Consequently, data are inadequate to perform an analysis of the adverse reaction incidence related to clinically-relevant age subgroups.

Other Adverse Reactions

In the paragraphs that follow, the frequencies of less commonly reported adverse clinical reactions are presented. Because the reports include reactions observed in open and uncontrolled premarketing studies (n= 979), the role of COPAXONE in their causation cannot be reliably determined. Furthermore, variability associated with adverse reaction reporting, the terminology

used to describe adverse reactions, etc., limit the value of the quantitative frequency estimates provided. Reaction frequencies are calculated as the number of patients who used COPAXONE and reported a reaction divided by the total number of patients exposed to COPAXONE. All reported reactions are included except those already listed in the previous table, those too general to be informative, and those not reasonably associated with the use of the drug. Reactions are further classified within body system categories and enumerated in order of decreasing frequency using the following definitions: *Frequent* adverse reactions are defined as those occurring in at least 1/100 patients and *infrequent* adverse reactions are those occurring in 1/100 to 1/1,000 patients.

Body as a Whole:

Frequent: Abscess

Infrequent: Injection site hematoma, moon face, cellulitis, hernia, injection site abscess, serum sickness, suicide attempt, injection site hypertrophy, injection site melanosis, lipoma, and photosensitivity reaction.

Cardiovascular:

Frequent: Hypertension.

Infrequent: Hypotension, midsystolic click, systolic murmur, atrial fibrillation, bradycardia, fourth heart sound, postural hypotension, and varicose veins.

Digestive:

Infrequent: Dry mouth, stomatitis, burning sensation on tongue, cholecystitis, colitis, esophageal ulcer, esophagitis, gastrointestinal carcinoma, gum hemorrhage, hepatomegaly, increased appetite, melena, mouth ulceration, pancreas disorder, pancreatitis, rectal hemorrhage, tenesmus, tongue discoloration, and duodenal ulcer.

Endocrine:

Infrequent: Goiter, hyperthyroidism, and hypothyroidism.

Gastrointestinal:

Frequent: Bowel urgency, oral moniliasis, salivary gland enlargement, tooth caries, and ulcerative stomatitis.

Hemic and Lymphatic:

Infrequent: Leukopenia, anemia, cyanosis, eosinophilia, hematemesis, lymphedema, pancytopenia, and splenomegaly.

Metabolic and Nutritional:

Infrequent: Weight loss, alcohol intolerance, Cushing's syndrome, gout, abnormal healing, and xanthoma.

Musculoskeletal:

Infrequent: Arthritis, muscle atrophy, bone pain, bursitis, kidney pain, muscle disorder, myopathy, osteomyelitis, tendon pain, and tenosynovitis.

Nervous:

Frequent: Abnormal dreams, emotional lability, and stupor.

Infrequent: Aphasia, ataxia, convulsion, circumoral paresthesia, depersonalization, hallucinations, hostility, hypokinesia, coma, concentration disorder, facial paralysis, decreased libido, manic reaction, memory impairment, myoclonus, neuralgia, paranoid reaction, paraplegia, psychotic depression, and transient stupor.

Respiratory:

Frequent: Hyperventilation and hay fever.

Infrequent: Asthma, pneumonia, epistaxis, hypoventilation, and voice alteration.

Skin and Appendages:

Frequent: Eczema, herpes zoster, pustular rash, skin atrophy, and warts.

Infrequent: Dry skin, skin hypertrophy, dermatitis, furunculosis, psoriasis, angioedema, contact dermatitis, erythema nodosum, fungal dermatitis, maculopapular rash, pigmentation, benign skin neoplasm, skin carcinoma, skin striae, and vesiculobullous rash.

Special Senses:

Frequent: Visual field defect.

Infrequent: Dry eyes, otitis externa, ptosis, cataract, corneal ulcer, mydriasis, optic neuritis, photophobia, and taste loss.

Urogenital:

Frequent: Amenorrhea, hematuria, impotence, menorrhagia, suspicious papanicolaou smear, urinary frequency, and vaginal hemorrhage.

Infrequent: Vaginitis, flank pain (kidney), abortion, breast engorgement, breast enlargement, carcinoma *in situ* cervix, fibrocystic breast, kidney calculus, nocturia, ovarian cyst, priapism, pyelonephritis, abnormal sexual function, and urethritis.

COPAXONE 40 mg per mL three times per week

Among 943 patients treated with COPAXONE 40 mg per mL three times per week in a blinded, placebo-controlled trial, approximately 3% of the subjects discontinued treatment because of an adverse reaction. The most common adverse reactions were injection site reactions, which were also the most common cause of discontinuation.

Table 2 lists signs and symptoms that occurred in at least 2% of patients treated with COPAXONE 40 mg per mL in the blinded, placebo-controlled trial. These signs and symptoms were numerically more common in patients treated with COPAXONE 40 mg per mL than in patients treated with placebo. Adverse reactions were usually mild in intensity.

Table 2: Adverse Reactions in a Controlled Clinical Trial with an Incidence $\geq 2\%$ of Patients and More Frequent with COPAXONE (40 mg per mL Three Times per Week) than with Placebo

		COPAXONE 40 mg/mL (n=943) %	Placebo (n=461) %
General Disorders And Administration Site Conditions	Injection Site Erythema	22	2
	Injection Site Pain	10	2
	Injection Site Mass	6	0
	Injection Site Pruritus	6	0
	Injection Site Edema	6	0
	Pyrexia	3	2
	Influenza-like Illness	3	2
	Injection Site Inflammation	2	0
	Chills	2	0
	Chest Pain	2	1
Infections And Infestations	Nasopharyngitis	11	9
	Respiratory Tract Infection Viral	3	2
Respiratory, Thoracic and Mediastinal Disorders	Dyspnea	3	0
Vascular Disorders	Vasodilatation	3	0
Gastrointestinal Disorders	Nausea	2	1
Skin And Subcutaneous Tissue Disorders	Erythema	2	0
	Rash	2	1

No new adverse reactions appeared in subjects treated with COPAXONE 40 mg per mL three times per week as compared to subjects treated with COPAXONE 20 mg per mL per day in clinical trials and during postmarketing experience. Data on adverse reactions occurring in the controlled clinical trial of COPAXONE 40 mg per mL were analyzed to evaluate differences based on sex. No clinically significant differences were identified. Ninety-eight percent of patients in this clinical trial were Caucasian and the majority were between the ages of 18 and 50. Consequently, data are inadequate to perform an analysis of the adverse reaction incidence related to clinically-relevant age groups.

6.2 Postmarketing Experience

The following adverse reactions have been identified during postapproval use of COPAXONE. Because these reactions are reported voluntarily from a population of uncertain size, it is not always possible to reliably estimate their frequency or establish a causal relationship to drug exposure.

Body as a Whole: sepsis; SLE syndrome; hydrocephalus; enlarged abdomen; allergic reaction; anaphylactoid reaction

Cardiovascular System: thrombosis; peripheral vascular disease; pericardial effusion; myocardial infarct; deep thrombophlebitis; coronary occlusion; congestive heart failure; cardiomyopathy; cardiomegaly; arrhythmia; angina pectoris

Digestive System: tongue edema; stomach ulcer; hemorrhage; eructation

Hemic and Lymphatic System: thrombocytopenia; lymphoma-like reaction; acute leukemia

Hepatobiliary Disorders: cholelithiasis; liver function abnormality; cirrhosis of the liver; hepatitis; hepatic injury [see *Warnings and Precautions (5.5)*]

Metabolic and Nutritional Disorders: hypercholesterolemia

Musculoskeletal System: rheumatoid arthritis; generalized spasm

Nervous System: myelitis; meningitis; CNS neoplasm; cerebrovascular accident; brain edema; abnormal dreams; aphasia; convulsion; neuralgia

Respiratory System: pulmonary embolus; pleural effusion; carcinoma of lung

Special Senses: glaucoma; blindness

Urogenital System: urogenital neoplasm; urine abnormality; ovarian carcinoma; nephrosis; kidney failure; breast carcinoma; bladder carcinoma; urinary frequency

7 DRUG INTERACTIONS

Interactions between COPAXONE and other drugs have not been fully evaluated. Results from existing clinical trials do not suggest any significant interactions of COPAXONE with therapies commonly used in MS patients, including the concurrent use of corticosteroids for up to 28 days. COPAXONE has not been formally evaluated in combination with interferon beta.

8 USE IN SPECIFIC POPULATIONS

8.1 Pregnancy

Risk Summary

Available human data on the use of COPAXONE in pregnant women are not sufficient to support conclusions about drug-associated risk for major birth defects and miscarriage. Administration of glatiramer acetate by subcutaneous injection to pregnant rats and rabbits resulted in no adverse effects on embryofetal or offspring development (see *Data*).

The estimated background risk of major birth defects and miscarriage for the indicated population is unknown. In the US general population, the estimated background risk of major birth defects and miscarriage in clinically recognized pregnancies is 2% to 4% and 15% to 20%, respectively.

Data

Human Data

There are no adequate and well-controlled studies of COPAXONE in pregnant women. The available postmarketing reports, case series, and small cohort studies do not provide sufficient information to support conclusions about drug-associated risk for major birth defects and miscarriage.

Animal Data

In rats or rabbits receiving glatiramer acetate by subcutaneous injection during the period of organogenesis, no adverse effects on embryofetal development were observed at doses up to 37.5 mg/kg/day (18 and 36 times, respectively, the therapeutic human dose of 20 mg/day on a mg/m² basis). In rats receiving subcutaneous glatiramer acetate at doses of up to 36 mg/kg from day 15 of pregnancy throughout lactation, no significant effects on delivery or on offspring growth and development were observed.

8.2 Lactation

Risk Summary

There are no data on the presence of glatiramer acetate in human milk, the effects on breastfed infants, or the effects on milk production.

The developmental and health benefits of breastfeeding should be considered along with the mother's clinical need for COPAXONE and any potential adverse effects on the breastfed infant from COPAXONE or from the underlying maternal condition.

8.4 Pediatric Use

The safety and effectiveness of COPAXONE have not been established in patients under 18 years of age.

8.5 Geriatric Use

COPAXONE has not been studied in elderly patients.

8.6 Use in Patients with Impaired Renal Function

The pharmacokinetics of glatiramer acetate in patients with impaired renal function have not been determined.

11 DESCRIPTION

Glatiramer acetate, the active ingredient of COPAXONE, consists of the acetate salts of synthetic polypeptides, containing four naturally occurring amino acids: L-glutamic acid, L-alanine, L-tyrosine, and L-lysine with an average molar fraction of 0.141, 0.427, 0.095, and 0.338, respectively. The average molecular weight of glatiramer acetate is 5,000 – 9,000 daltons. Glatiramer acetate is identified by specific antibodies.

Chemically, glatiramer acetate is designated L-glutamic acid polymer with L-alanine, L-lysine and L-tyrosine, acetate (salt). Its structural formula is:

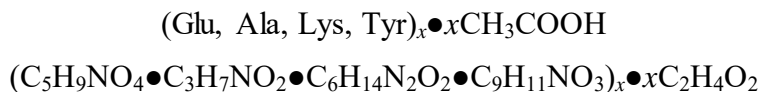

CAS - 147245-92-9

COPAXONE is a clear, colorless to slightly yellow, sterile, nonpyrogenic solution for subcutaneous injection. Each 1 mL of COPAXONE solution contains 20 mg or 40 mg of glatiramer acetate and the following inactive ingredient: 40 mg of mannitol. The pH of the solutions is approximately 5.5 to 7.0. The biological activity of glatiramer acetate is determined by its ability to block the induction of experimental autoimmune encephalomyelitis (EAE) in mice.

12 CLINICAL PHARMACOLOGY

12.1 Mechanism of Action

The mechanism(s) by which glatiramer acetate exerts its effects in patients with MS are not fully understood. However, glatiramer acetate is thought to act by modifying immune processes that are believed to be responsible for the pathogenesis of MS. This hypothesis is supported by findings of studies that have been carried out to explore the pathogenesis of experimental autoimmune encephalomyelitis, a condition induced in animals through immunization against central nervous system derived material containing myelin and often used as an experimental animal model of MS. Studies in animals and *in vitro* systems suggest that upon its administration, glatiramer acetate-specific suppressor T-cells are induced and activated in the periphery.

Because glatiramer acetate can modify immune functions, concerns exist about its potential to alter naturally-occurring immune responses. There is no evidence that glatiramer acetate does this, but this has not been systematically evaluated [*see Warnings and Precautions (5.4)*].

12.3 Pharmacokinetics

Results obtained in pharmacokinetic studies performed in humans (healthy volunteers) and animals support that a substantial fraction of the therapeutic dose delivered to patients subcutaneously is hydrolyzed locally. Larger fragments of glatiramer acetate can be recognized by glatiramer acetate-reactive antibodies. Some fraction of the injected material, either intact or partially hydrolyzed, is presumed to enter the lymphatic circulation, enabling it to reach regional lymph nodes, and some may enter the systemic circulation intact.

13 NONCLINICAL TOXICOLOGY

13.1 Carcinogenesis, Mutagenesis, Impairment of Fertility

Carcinogenesis

In a 2-year carcinogenicity study, mice were administered up to 60 mg/kg/day glatiramer acetate by subcutaneous injection (up to 15 times the human therapeutic dose of 20 mg/day on a mg/m² basis). No increase in systemic neoplasms was observed. In males receiving the 60-mg/kg/day dose, there was an increased incidence of fibrosarcomas at the injection sites. These sarcomas were associated with skin damage precipitated by repetitive injections of an irritant over a limited skin area.

In a 2-year carcinogenicity study, rats were administered up to 30 mg/kg/day glatiramer acetate by subcutaneous injection (up to 15 times the human therapeutic dose on a mg/m² basis). No increase in neoplasms was observed.

Mutagenesis

Glatiramer acetate was not mutagenic in *in vitro* (Ames test, mouse lymphoma tk) assays. Glatiramer acetate was clastogenic in two separate *in vitro* chromosomal aberration assays in cultured human lymphocytes but not clastogenic in an *in vivo* mouse bone marrow micronucleus assay.

Impairment of Fertility

When glatiramer acetate was administered by subcutaneous injection prior to and during mating (males and females) and throughout gestation and lactation (females) at doses up to 36 mg/kg/day (18 times the human therapeutic dose on a mg/m² basis) no adverse effects were observed on reproductive or developmental parameters.

14 CLINICAL STUDIES

Evidence supporting the effectiveness of COPAXONE derives from five placebo-controlled trials, four of which used a COPAXONE dose of 20 mg per mL per day and one of which used a COPAXONE dose of 40 mg per mL three times per week.

COPAXONE 20 mg per mL per day

Study 1 was performed at a single center. Fifty patients were enrolled and randomized to receive daily doses of either COPAXONE, 20 mg per mL subcutaneously, or placebo (COPAXONE: n=25; placebo: n=25). Patients were diagnosed with RRMS by standard criteria, and had at least 2 exacerbations during the 2 years immediately preceding enrollment. Patients were ambulatory, as evidenced by a score of no more than 6 on the Kurtzke Disability Scale Score (DSS), a standard scale ranging from 0–Normal to 10–Death due to MS. A score of 6 is defined as one at which a patient is still ambulatory with assistance; a score of 7 means the patient must use a wheelchair.

Patients were examined every 3 months for 2 years, as well as within several days of a presumed exacerbation. To confirm an exacerbation, a blinded neurologist had to document objective

neurologic signs, as well as document the existence of other criteria (e.g., the persistence of the neurological signs for at least 48 hours).

The protocol-specified primary outcome measure was the proportion of patients in each treatment group who remained exacerbation free for the 2 years of the trial, but two other important outcomes were also specified as endpoints: the frequency of attacks during the trial, and the change in the number of attacks compared with the number which occurred during the previous 2 years.

Table 3 presents the values of the three outcomes described above, as well as several protocol-specified secondary measures. These values are based on the intent-to-treat population (i.e., all patients who received at least 1 dose of treatment and who had at least 1 on-treatment assessment):

Table 3: Study 1 Efficacy Results

	COPAXONE 20 mg/mL (n=25)	Placebo (n=25)	P-Value
% Relapse-Free Patients	14/25 (56%)	7/25 (28%)	0.085
Mean Relapse Frequency	0.6/2 years	2.4/2 years	0.005
Reduction in Relapse Rate Compared to Prestudy	3.2	1.6	0.025
Median Time to First Relapse (days)	>700	150	0.03
% of Progression-Free* Patients	20/25 (80%)	13/25 (52%)	0.07

*Progression was defined as an increase of at least 1 point on the DSS, persisting for at least 3 consecutive months.

Study 2 was a multicenter trial of similar design which was performed in 11 US centers. A total of 251 patients (COPAXONE: n=125; placebo: n=126) were enrolled. The primary outcome measure was the Mean 2-Year Relapse Rate. Table 4 presents the values of this outcome for the intent-to-treat population, as well as several secondary measures:

Table 4: Study 2 Efficacy Results

	COPAXONE 20 mg/mL (n=125)	Placebo (n=126)	P-Value
Mean No. of Relapses	1.19/2 years	1.68 /2 years	0.055
% Relapse-Free Patients	42/125 (34%)	34/126 (27%)	0.25
Median Time to First Relapse (days)	287	198	0.23
% of Progression-Free Patients	98/125 (78%)	95/126 (75%)	0.48
Mean Change in DSS	-0.05	+0.21	0.023

In both studies, COPAXONE exhibited a clear beneficial effect on relapse rate, and it is based on this evidence that COPAXONE is considered effective.

In Study 3, 481 patients who had recently (within 90 days) experienced an isolated demyelinating event and who had lesions typical of multiple sclerosis on brain MRI were randomized to receive either COPAXONE 20 mg per mL (n=243) or placebo (n=238). The primary outcome measure was time to development of a second exacerbation. Patients were followed for up to three years or until they reached the primary endpoint. Secondary outcomes were brain MRI measures, including number of new T2 lesions and T2 lesion volume.

Time to development of a second exacerbation was significantly delayed in patients treated with COPAXONE compared to placebo (Hazard Ratio = 0.55; 95% confidence interval 0.40 to 0.77; Figure 1). The Kaplan-Meier estimates of the percentage of patients developing a relapse within 36 months were 42.9% in the placebo group and 24.7% in the COPAXONE group.

Figure 1: Time to Second Exacerbation

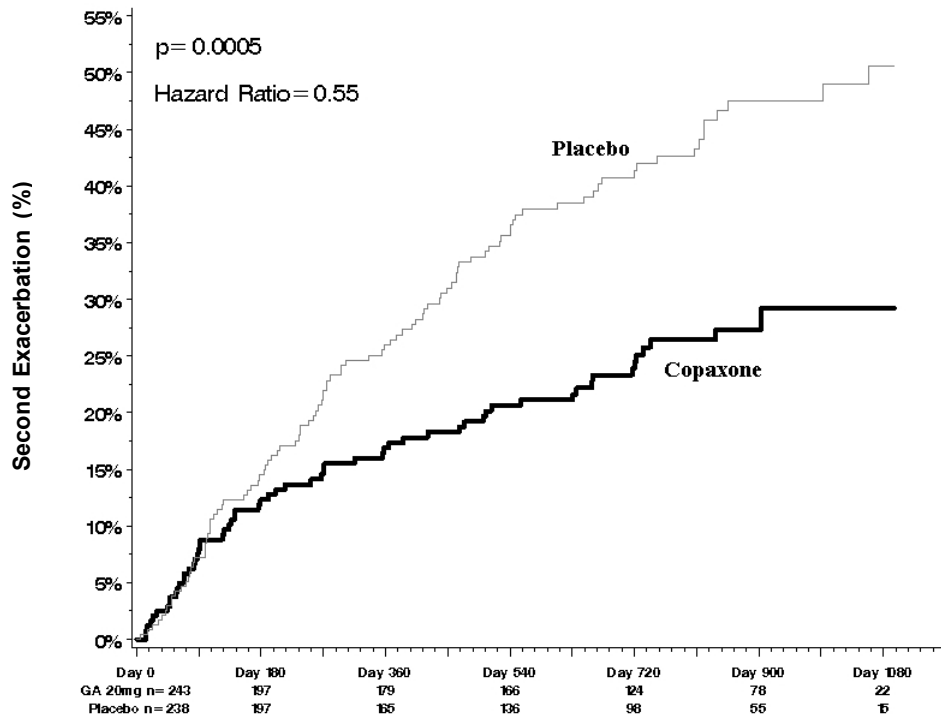

Patients treated with COPAXONE demonstrated fewer new T2 lesions at the last observation (rate ratio 0.41; confidence interval 0.28 to 0.59; $p < 0.0001$). Additionally, baseline-adjusted T2 lesion volume at the last observation was lower for patients treated with COPAXONE (ratio of 0.89; confidence interval 0.84 to 0.94; $p = 0.0001$).

Study 4 was a multinational study in which MRI parameters were used both as primary and secondary endpoints. A total of 239 patients with RRMS (COPAXONE: $n=119$; and placebo: $n=120$) were randomized. Inclusion criteria were similar to those in the second study with the additional criterion that patients had to have at least one Gd-enhancing lesion on the screening MRI. The patients were treated in a double-blind manner for nine months, during which they underwent monthly MRI scanning. The primary endpoint for the double-blind phase was the total cumulative number of T1 Gd-enhancing lesions over the nine months. Table 5 summarizes the results for the primary outcome measure monitored during the trial for the intent-to-treat cohort.

Table 5: Study 4 MRI Results

	COPAXONE 20 mg/mL (n=119)	Placebo (n=120)	P-Value
Medians of the Cumulative Number of T1 Gd-Enhancing Lesions	11	17	0.0030

Figure 2 displays the results of the primary outcome on a monthly basis.

Figure 2: Median Cumulative Number of Gd-Enhancing Lesions

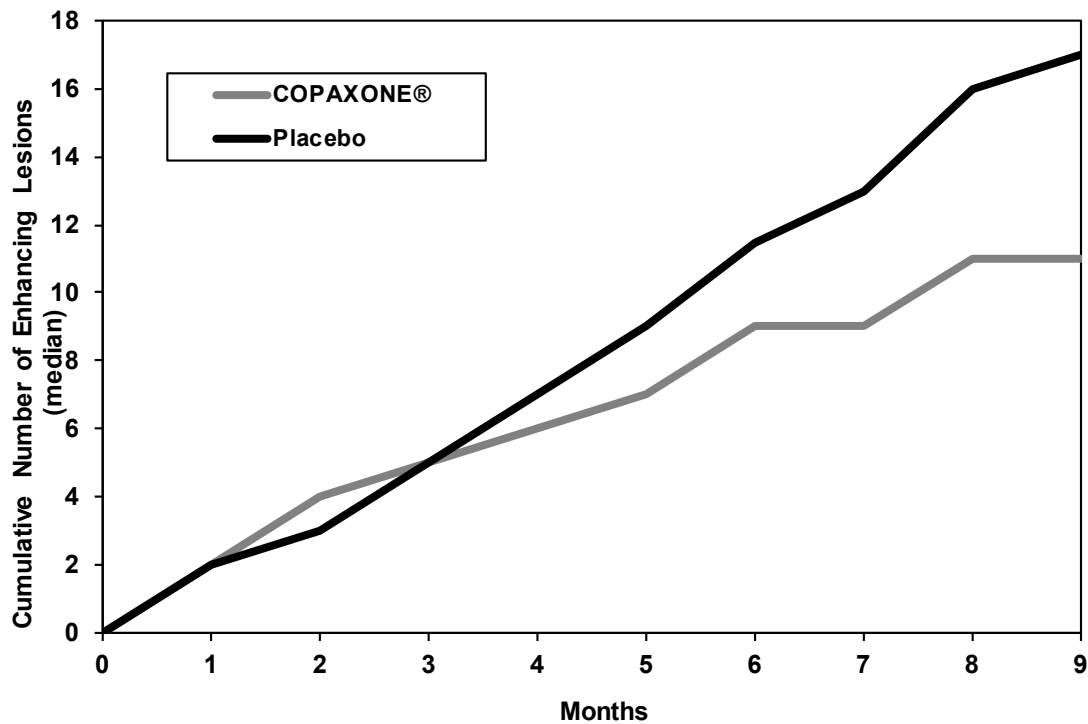

COPAXONE 40 mg per mL three times per week

Study 5 was a double-blind, placebo-controlled, multinational study with a total of 1404 patients with RRMS randomized in a 2:1 ratio to receive either COPAXONE 40 mg per mL (n=943) or placebo (n=461) three times a week for 12 months. Patients had a median of 2 relapses in the 2 years prior to screening and had not received any interferon-beta for at least 2 months prior to screening. Baseline EDSS scores ranged from 0 to 5.5 with a median of 2.5. Neurological evaluations were performed at baseline, every three months, and at unscheduled visits for suspected relapse or early termination. MRI was performed at baseline, months 6 and 12, or early termination. A total of 91% of those assigned to COPAXONE and 93% of those assigned to placebo completed treatment at 12 months.

The primary outcome measure was the total number of confirmed relapses (persistence of neurological symptoms for at least 48 hours confirmed on examination with objective signs). The effect of COPAXONE on several magnetic resonance imaging (MRI) variables, including number of new or enlarging T2 lesions and number of enhancing lesions on T1-weighted images, was also measured at months 6 and 12.

Table 6 presents the results for the intent-to-treat population.

Table 6: Study 5 Efficacy and MRI Results

	COPAXONE 40 mg/mL (n=943)	Placebo (n=461)	P-Value
Clinical Endpoints			
Number of confirmed relapses during the 12-month placebo-controlled phase			
Adjusted Mean Estimates	0.331	0.505	<0.0001
Relative risk reduction	34%		
MRI Endpoints			
Cumulative number of new or enlarging T2 lesions at Months 6 and 12			
Adjusted Mean Estimates	3.650	5.592	<0.0001
Relative risk reduction	35%		
Cumulative number of enhancing lesions on T1-weighted images at Months 6 and 12			
Adjusted Mean Estimates	0.905	1.639	<0.0001
Relative risk reduction	45%		

16 HOW SUPPLIED/STORAGE AND HANDLING

COPAXONE (glatiramer acetate injection) is a clear, colorless to slightly yellow, sterile, nonpyrogenic solution supplied as:

- 20 mg per mL in a single-dose, prefilled syringe with a white plunger, in individual blister packages supplied in 30-count cartons (NDC 68546-317-30).
- 40 mg per mL in a single-dose, prefilled syringe with a blue plunger, in individual blister packages supplied in 12-count cartons (NDC 68546-325-12).

Store COPAXONE refrigerated at 2°C to 8°C (36°F to 46°F). If needed, the patient may store COPAXONE at room temperature, 15°C to 30°C (59°F to 86°F), for up to one month, but refrigeration is preferred. Avoid exposure to higher temperatures or intense light. Do not freeze COPAXONE. If a COPAXONE syringe freezes, it should be discarded.

17 PATIENT COUNSELING INFORMATION

Advise the patient to read the FDA-approved patient labeling (Patient Information and Instructions for Use).

Immediate Post-Injection Reaction

Advise patients that COPAXONE may cause various symptoms after injection, including flushing, chest pain, palpitations, tachycardia, anxiety, dyspnea, constriction of the throat, and urticaria. These symptoms occur within seconds to minutes after injection and are generally transient and self-limited and do not require specific treatment. Inform patients that these symptoms may occur early or may have their onset several months after the initiation of treatment. A patient may experience one or several episodes of these symptoms.

Chest Pain

Advise patients that they may experience transient chest pain either as part of the Immediate Post-Injection Reaction or in isolation. Inform patients that the pain should be transient. Some patients may experience more than one such episode, usually beginning at least one month after the initiation of treatment. Patients should be advised to seek medical attention if they experience chest pain of unusual duration or intensity.

Lipoatrophy and Skin Necrosis at Injection Site

Advise patients that localized lipoatrophy, and rarely, skin necrosis may occur at injection sites. Instruct patients to follow proper injection technique and to rotate injection areas and sites with each injection to minimize these risks.

Hepatic Injury

Advise patients that hepatic injury, including hepatic failure and hepatitis with jaundice, has been reported with the use of COPAXONE. Educate patients about the signs and symptoms of hepatic injury and instruct patients to report them immediately to their healthcare provider [*see Warnings and Precautions (5.5)*].

Pregnancy

Instruct patients that if they are pregnant or plan to become pregnant while taking COPAXONE they should inform their physician [*see Use in Specific Populations (8.1)*].

Lactation

Advise patients to notify their healthcare provider if they are breastfeeding or intend to breastfeed during COPAXONE therapy [*see Use in Specific Populations (8.2)*].

Instructions for Use

Instruct patients to read the COPAXONE Patient Information leaflet carefully. COPAXONE 20 mg per mL and COPAXONE 40 mg per mL are not interchangeable. COPAXONE 20 mg per mL is administered daily and COPAXONE 40 mg per mL is administered three times per week. Caution patients to use aseptic technique. The first injection should be performed under the supervision of a health care professional. Instruct patients to rotate injection areas and sites with each injection. Caution patients against the reuse of needles or syringes. Instruct patients in safe disposal procedures.

Storage Conditions

Advise patients that the recommended storage condition for COPAXONE is refrigeration at 36°F to 46°F (2°C to 8°C). If needed, the patient may store COPAXONE at room temperature, 59°F to 86°F (15°C to 30°C), for up to one month, but refrigeration is preferred. COPAXONE should not be exposed to higher temperatures or intense light. Do not freeze COPAXONE.



Marketed by: Teva Neuroscience, Inc., Parsippany, NJ 07054

Distributed by: Teva Pharmaceuticals USA, Inc., Parsippany, NJ 07054

©2020 Teva Neuroscience, Inc.

COP-007

Patient Information
COPAXONE (co-PAX-own)
(glatiramer acetate injection)
for subcutaneous use

Read this Patient Information before you start using COPAXONE and each time you get a refill. There may be new information. This information does not take the place of talking with your doctor about your medical condition or your treatment.

What is COPAXONE?

COPAXONE is a prescription medicine that is used to treat relapsing forms of multiple sclerosis (MS), to include clinically isolated syndrome, relapsing-remitting disease, and active secondary progressive disease, in adults.

It is not known if COPAXONE is safe and effective in children under 18 years of age.

Who should not use COPAXONE?

- Do not use COPAXONE if you are allergic to glatiramer acetate, mannitol or any of the ingredients in COPAXONE. See the end of this leaflet for a complete list of the ingredients in COPAXONE.

What should I tell my doctor before using COPAXONE?

Before you use COPAXONE, tell your doctor if you:

- are pregnant or plan to become pregnant. It is not known if COPAXONE will harm your unborn baby.
- are breastfeeding or plan to breastfeed. It is not known if COPAXONE passes into your breast milk. Talk to your doctor about the best way to feed your baby while using COPAXONE.

Tell your doctor about all the medicines you take, including prescription and over-the-counter medicines, vitamins, and herbal supplements.

COPAXONE may affect the way other medicines work, and other medicines may affect how COPAXONE works.

Know the medicines you take. Keep a list of your medicines with you to show your doctor and pharmacist when you get a new medicine.

How should I use COPAXONE?

- For detailed instructions, see the **Instructions for Use** at the end of this leaflet for complete information on how to use COPAXONE.
- Your doctor will tell you how much COPAXONE to use and when to use it.
- COPAXONE is given by injection under your skin (subcutaneously).
- Use COPAXONE exactly as your doctor tells you to use it.
- Since every body type is different, talk with your doctor about the injection areas that are best for you.

- You should receive your first dose of COPAXONE with a doctor or nurse present. This might be at your doctor's office or with a visiting home health nurse who will teach you how to give your COPAXONE injections.

What are the possible side effects of COPAXONE?

COPAXONE may cause serious side effects, including:

- **Immediate Post-Injection Reactions.** Serious side effects may happen right after or within minutes after you inject COPAXONE at any time during your course of treatment. Call your doctor right away if you have any of these immediate post-injection reaction symptoms including:
 - redness to your cheeks or other parts of the body (flushing)
 - chest pain
 - fast heart beat
 - anxiety
 - breathing problems or tightness in your throat
 - swelling, rash, hives, or itching

If you have symptoms of an immediate post-injection reaction, do not give yourself more injections until a doctor tells you to.

- **Chest Pain.** You can have chest pain as part of an immediate post-injection reaction or by itself. This type of chest pain usually lasts a few minutes and can begin around 1 month after you start using COPAXONE. Call your doctor right away if you have chest pain while using COPAXONE.
- **Damage to your skin.** Damage to the fatty tissue just under your skin's surface (lipoatrophy) and, rarely, death of your skin tissue (necrosis) can happen when you use COPAXONE. Damage to the fatty tissue under your skin can cause a "dent" at the injection site that may not go away. You can reduce your chance of developing these problems by:
 - following your doctor's instructions for how to use COPAXONE
 - choosing a different injection area each time you use COPAXONE. See Step 4 in the Instructions for Use, "Choose your injection area".
- **Liver problems.** Liver problems, including liver failure, can occur with COPAXONE. Call your healthcare provider right away if you have symptoms, such as:
 - nausea
 - loss of appetite
 - tiredness
 - dark colored urine and pale stools

- yellowing of your skin or the white part of your eye
- bleeding more easily than normal
- confusion
- sleepiness

The most common side effects of COPAXONE include:

- skin problems at your injection site including:
 - redness
 - pain
 - swelling
 - itching
 - lumps
- rash
- shortness of breath
- flushing (vasodilation)

Tell your doctor if you have any side effect that bothers you or that does not go away.

These are not all the possible side effects of COPAXONE. For more information, ask your doctor or pharmacist.

Call your doctor for medical advice about side effects. You may report side effects to FDA at 1-800-FDA-1088.

How should I store COPAXONE?

- Store COPAXONE in the refrigerator between 36°F to 46°F (2°C to 8°C).
- When you are not able to refrigerate COPAXONE, you may store it for up to 1 month at room temperature between 59°F to 86°F (15°C to 30°C).
- Protect COPAXONE from light or high temperature.
- Do not freeze COPAXONE syringes. If a syringe freezes, throw it away in a sharps disposal container. **See Step 13 in the Instructions for Use, “Dispose of your needles and syringes”.**

Keep COPAXONE and all medicines out of the reach of children.

General information about the safe and effective use of COPAXONE.

Medicines are sometimes prescribed for purposes other than those listed in a Patient Information Leaflet. Do not use COPAXONE for a condition for which it was not prescribed. Do not give COPAXONE to other people, even if they have the same symptoms as you have. It may harm them.

This Patient Information Leaflet summarizes the most important information about COPAXONE. If you would like more information, talk with your doctor. You can ask your pharmacist or doctor for information about COPAXONE that is written for health professionals.

For more information, go to www.copaxone.com or call 1-800-887-8100.

What are the ingredients in COPAXONE?

Active ingredient: glatiramer acetate

Inactive ingredients: mannitol

COPPL-005

Revised: July 2020

Instructions for Use
COPAXONE (co-PAX-own)
(glatiramer acetate injection)
for subcutaneous use

For subcutaneous injection only.

Do not inject COPAXONE in your veins (intravenously).

Do not re-use your COPAXONE prefilled syringes.

Do not share your COPAXONE prefilled syringes with another person. You may give another person an infection or get an infection from them.

You should receive your first dose of COPAXONE with a doctor or nurse present. This might be at your doctor's office or with a visiting home health nurse who will show you how to give your own injections.

COPAXONE comes in either a 20 mg Prefilled Syringe with needle attached or a 40 mg Prefilled Syringe with needle attached. How often a dose is given depends on the product strength that is prescribed. Your doctor will prescribe the correct dose for you.

Instructions for Using Your COPAXONE 20 mg Prefilled Syringe :

- **COPAXONE 20 mg** is injected 1 time each day, in the fatty layer under your skin (subcutaneously).
- Each COPAXONE 20 mg prefilled syringe is for single use (1 time use) only.
- The COPAXONE 20 mg dose is packaged in boxes of 30 prefilled syringes with needles attached. COPAXONE 20 mg prefilled syringes have **white** plungers.

Instructions for Using Your COPAXONE 40 mg Prefilled Syringe:

- **COPAXONE 40 mg** is injected 3 times each week, in the fatty layer under your skin (subcutaneously).
- COPAXONE 40 mg should be given on the same 3 days each week, if possible for example, Monday, Wednesday, and Friday. Give your COPAXONE injections at least 48 hours (2 days) apart.
- Each COPAXONE 40 mg prefilled syringe is for single use (1 time use) only.
- The COPAXONE 40 mg dose is packaged in boxes of 12 prefilled syringes with needles attached. COPAXONE 40 mg prefilled syringes have **blue** plungers.

How do I inject COPAXONE?

Step 1: Gather the supplies you will need to inject COPAXONE. **See Figure A.**

- 1 blister pack with a COPAXONE Prefilled Syringe with needle attached
- Alcohol wipe (not supplied)
- Dry cotton ball (not supplied)
- A place to record your injections, like a notebook (not supplied)
- Sharps disposal container (not supplied). **See Step 13 below, “Dispose of your needles and syringes”.**

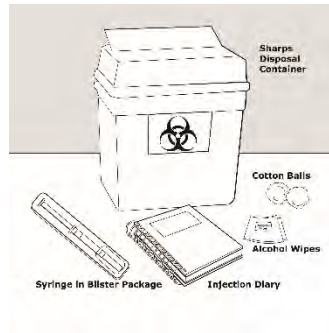

Figure A

Step 2: Remove only 1 blister pack from the COPAXONE prefilled syringe carton. See **Figure B**.

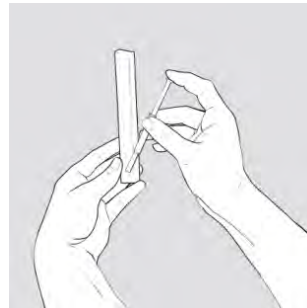

Figure B

- Place the supplies you will need on a clean, flat surface in a well-lit area.
- After you remove 1 blister pack from the carton, keep all unused syringes in the carton and store them in the refrigerator.
- Let the blister pack, with the syringe inside, warm to room temperature for about 20 minutes.
- Wash your hands. Be careful not to touch your face or hair after washing your hands.

Step 3: Look closely at your COPAXONE prefilled syringe.

- There may be small air bubbles in the syringe. **Do not** try to push the air bubble from the syringe before giving your injection so you do not lose any medicine.

- Check the liquid medicine in the syringe before you give your injection. The liquid in the syringe should look clear, and colorless, and may look slightly yellow. If the liquid is cloudy or contains any particles, do not use the syringe and throw it away in a sharps disposal container. **See Step 13 below, “Dispose of your needles and syringes.”**

Step 4: Choose your injection area. **See Figure C.**

See the injection areas you should use on your body. Talk with your doctor about the injection areas that are best for you.

- The possible injection areas on your body include (**See Figure C**):
 - your stomach area (abdomen) around the belly button
 - the back of your upper arms
 - upper hips (below your waist)
 - your thighs (above your knees)

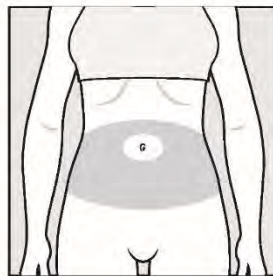

Abdomen
Avoid about 2 inches around the belly button

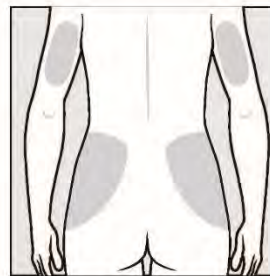

Back of Hips and Arms
Fleshy areas of the upper hips, always below the waist

Fleshy areas of the upper back portion of the arms

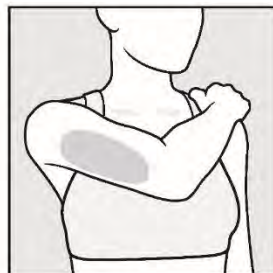

Arms
Fleshy areas of the upper back portion

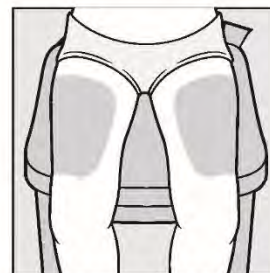

Thighs
About 2 inches above the knee and 2 inches below the groin

Figure C

- For each COPAXONE dose, choose a different injection area from 1 of the areas shown above. **See Figure C.**

- **Do not stick the needle in the same place (site) more than 1 time each week.** Each injection area contains multiple injection sites for you to choose from. Avoid injecting in the same site over and over again.
- Keep a record of the sites where you give your injection each day so you will remember where you already injected.

Step 5: Prepare to give your injection.

- There are some injection areas on your body that are hard to reach (like the back of your arm). You may need help from someone who has been instructed on how to give your injection if you cannot reach certain injection areas.
- Do not inject in sites where the skin has scarring or “dents”. Using scarred or dented skin for your injections may make your skin worse.

Step 6: Clean your injection site.

- Clean the injection site using the alcohol wipe and allow your skin to air dry. **See Figure D.**

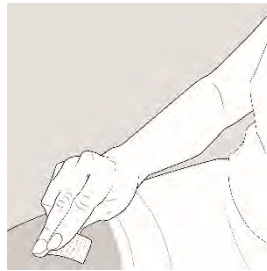

Figure D

Step 7: Pick up the syringe with 1 hand and hold it like a pencil. Remove the needle cover with your other hand and set it aside. **See Figure E.**

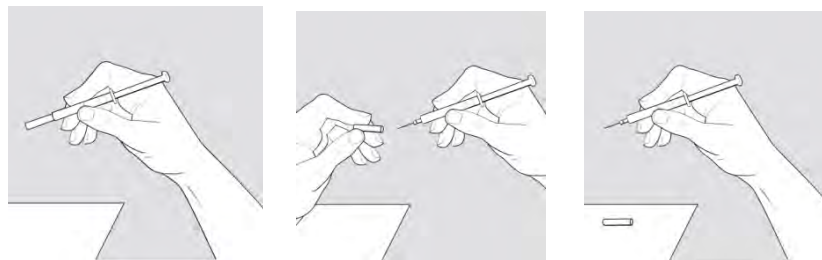

Figure E

Step 8: Pinch about a 2 inch fold of skin between your thumb and index finger. **See Figure F.**

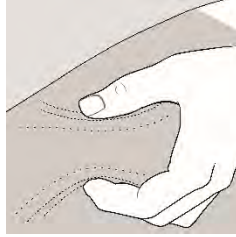

Figure F

Step 9: Giving your injection.

- Rest the heel of your hand holding the syringe against your skin at the injection site. Insert the needle at a 90 degree angle straight into your skin. **See Figure G.**

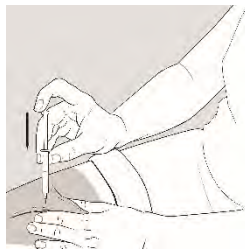

Figure G

- When the needle is all the way into your skin, release the fold of skin. **See Figure H.**



Figure H

Step 10: Give your COPAXONE injection.

To inject the medicine, hold the syringe steady and slowly push down the plunger. **See Figure I.**

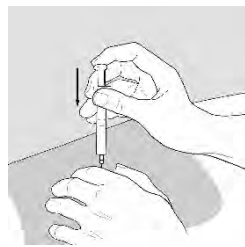

Figure I

Step 11: Remove the needle.

After you have injected all of the medicine, pull the needle straight out. **See Figure J.**

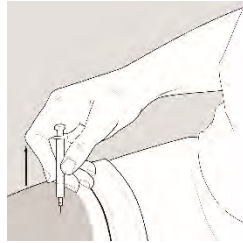

Figure J

Step 12: Use a clean, dry cotton ball to gently press on the injection site for a few seconds. Do not rub the injection site or re-use the needle or syringe. **See Figure K.**

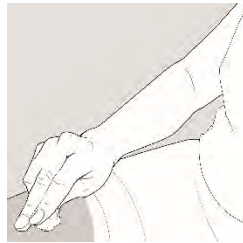

Figure K

Step 13: Dispose of your needles and syringes.

- Put your used needles and syringes in a FDA-cleared sharps disposal container right away after use. **Do not throw away (dispose of) loose needles and syringes in your household trash.**
- If you do not have a FDA-cleared sharps disposal container, you may use a household container that is:
 - made of a heavy-duty plastic,
 - can be closed with a tight-fitting, puncture-resistant lid, without sharps being able to come out,
 - upright and stable during use,
 - leak-resistant, and
 - properly labeled to warn of hazardous waste inside the container.
- When your sharps disposal container is almost full, you will need to follow your community guidelines for the right way to dispose of your sharps disposal container. There may be state or local laws about how you should throw away used needles and syringes. For more information about safe sharps disposal, and for specific information about sharps disposal in the state that you live in, go to the FDA's website at:
<http://www.fda.gov/safesharpsdisposal>.

- Do not dispose of your used sharps disposal container in your household trash unless your community guidelines permit this. Do not recycle your used sharps disposal container.



Figure L

This Patient Information and Instructions for Use has been approved by the U.S. Food and Drug Administration.

teva

Marketed by: Teva Neuroscience, Inc., Parsippany, NJ 07054

Distributed by: Teva Pharmaceuticals USA, Inc., Parsippany, NJ 07054

©2019 Teva Neuroscience, Inc.

COPIFU-004

Revised: December 2019

PRODUCT MONOGRAPH
INCLUDING PATIENT MEDICATION INFORMATION

PrDESCOVY®

(emtricitabine/tenofovir alafenamide) tablets

200 mg emtricitabine
10 mg* and 25 mg** tenofovir alafenamide

*as 11.2 mg tenofovir alafenamide hemifumarate

**as 28.0 mg tenofovir alafenamide hemifumarate

Antiretroviral Agent

Gilead Sciences Canada, Inc.
Mississauga, ON L5N 2W3

www.gilead.ca

Submission Control No: 221256

Date of Initial Approval:
April 28, 2016

Date of Revision:
September 23, 2019

RECENT MAJOR LABEL CHANGES

Indications (1)	09/2019
Indications, Pediatrics (1.1)	09/2019
Dosage and Administration, Dosing Considerations (4.1)	09/2019
Dosage and Administration, Recommended Dose and Dose Adjustment (4.2)	09/2019
Warnings and Precautions, Immune (7)	05/2019
Warnings and Precautions, Musculoskeletal (7)	09/2019
Warnings and Precautions, Pediatrics (7.1)	09/2019

TABLE OF CONTENTS

RECENT MAJOR LABEL CHANGES.....	2
TABLE OF CONTENTS.....	2
PART I: HEALTH PROFESSIONAL INFORMATION.....	4
1 INDICATIONS.....	4
1.1 Pediatrics (weighing \geq 25 kg).....	4
1.2 Geriatrics (\geq 65 years of age).....	4
2 CONTRAINDICATIONS.....	4
3 SERIOUS WARNINGS AND PRECAUTIONS BOX.....	4
4 DOSAGE AND ADMINISTRATION.....	5
4.1 Dosing Considerations.....	5
4.2 Recommended Dose and Dosage Adjustment.....	5
4.3 Missed Dose.....	6
5 OVERDOSAGE.....	6
6 DOSAGE FORMS, STRENGTHS, COMPOSITION AND PACKAGING.....	7
7 WARNINGS AND PRECAUTIONS.....	7
7.1 Special Populations.....	10
7.1.1 Patients Coinfected with HIV and HBV.....	10
7.1.2 Pregnant Women.....	10
7.1.3 Nursing Women.....	11
7.1.4 Pediatrics (weighing <25 kg).....	11
7.1.5 Geriatrics (\geq 65 years of age):.....	11
8 ADVERSE REACTIONS.....	12
8.1 Adverse Reaction Overview.....	12
8.2 Clinical Trial Adverse Drug Reactions.....	12
8.3 Less Common Clinical Trial Adverse Drug Reactions (<1%).....	13
8.4 Laboratory Abnormalities.....	14
8.5 Clinical Trials in Virologically Suppressed Patients.....	17
8.6 Clinical Trials in Adult Patients with Renal Impairment.....	17
8.7 Clinical Trials in Pediatric Patients (6 to <18 years of age).....	17
8.8 Post-Market Adverse Drug Reactions.....	18
9 DRUG INTERACTIONS.....	19
9.1 Drug-Drug Interactions.....	19
9.2 Drug-Food Interactions.....	26
9.3 Drug-Herb Interactions.....	26

DESCOVY (emtricitabine/tenofovir alafenamide*) tablets

*as tenofovir alafenamide hemifumarate

Product Monograph

9.4	Drug-Laboratory Interactions.....	27
10	ACTION AND CLINICAL PHARMACOLOGY.....	27
10.1	Mechanism of Action	27
10.2	Pharmacodynamics.....	27
10.3	Pharmacokinetics	28
11	STORAGE, STABILITY AND DISPOSAL.....	31
12	SPECIAL HANDLING INSTRUCTIONS	31
13	PHARMACEUTICAL INFORMATION.....	32
14	CLINICAL TRIALS	34
14.1	Study Demographics and Trial Design.....	34
14.2	Study Results	40
15	MICROBIOLOGY	51
16	NON-CLINICAL TOXICOLOGY	54
	PATIENT MEDICATION INFORMATION	57

DESCOVY®

(emtricitabine/tenofovir alafenamide*) tablets

*as tenofovir alafenamide hemifumarate

PART I: HEALTH PROFESSIONAL INFORMATION

1 INDICATIONS

DESCOVY is indicated in combination with other antiretrovirals (such as non-nucleoside reverse transcriptase inhibitors or protease inhibitors) for the treatment of human immunodeficiency virus type 1 (HIV-1) infection in adults and pediatric patients weighing ≥ 25 kg.

1.1 Pediatrics (weighing ≥ 25 kg)

The safety and efficacy of DESCOVY in children weighing ≥ 25 kg are based on data from an open-label clinical study (see **ADVERSE REACTIONS** and **CLINICAL TRIALS**).

Safety and efficacy of DESCOVY in children weighing less than 25 kg have not been established.

1.2 Geriatrics (≥ 65 years of age)

No differences in safety or efficacy have been observed between elderly patients and those < 65 years of age (see **ACTION** and **CLINICAL PHARMACOLOGY**).

2 CONTRAINDICATIONS

DESCOVY is contraindicated in patients with known hypersensitivity to any of the components of the product. For a complete listing, see the **DOSAGE FORMS, COMPOSITION AND PACKAGING** section of the Product Monograph.

3 SERIOUS WARNINGS AND PRECAUTIONS BOX

Serious Warnings and Precautions

- **Post-treatment Exacerbation of Hepatitis B Virus**

DESCOVY is not approved for the treatment of chronic hepatitis B virus (HBV) infection and the safety and efficacy of DESCOVY have not been established in patients coinfecting with HIV-1 and HBV. Discontinuation of DESCOVY therapy in patients coinfecting with HIV-1 and HBV may be associated with severe acute exacerbations of hepatitis due to the emtricitabine (FTC) or tenofovir alafenamide (TAF) components of DESCOVY. Hepatic function should be monitored closely with both clinical and laboratory follow-up for at least several months in patients who are coinfecting with HIV-1 and HBV and discontinue DESCOVY. If appropriate, initiation of anti-hepatitis B therapy may be warranted (see **WARNINGS AND PRECAUTIONS, Special Populations**).

4 DOSAGE AND ADMINISTRATION

4.1 Dosing Considerations

In adults and pediatric patients weighing ≥ 25 kg, DESCOVY is taken orally once daily with or without food (see **DRUG INTERACTIONS, Drug-Food Interactions**).

4.2 Recommended Dose and Dosage Adjustment

The choice of dose of DESCOVY depends on the other antiretroviral agents being coadministered:

- the 200/10 mg dose is recommended when DESCOVY is used in combination with an HIV-1 protease inhibitor that is administered with either ritonavir or COBI.
- the 200/25 mg dose is recommended when DESCOVY is used in combination with other antiretrovirals (i.e. non-nucleoside reverse transcriptase inhibitors, integrase inhibitors, maraviroc). This dose should not be used in combination with an HIV-1 protease inhibitor that is administered with either ritonavir or COBI.

Table 1 includes dosing recommendations based upon clinical data from third agents evaluated with DESCOVY in Study GS-US-311-1089 or drug interactions studies.

Table 1. Dose of DESCOVY according to third agent in the HIV treatment regimen

Dose of DESCOVY	Third agent in HIV treatment regimen
DESCOVY 200/10 mg once daily	Atazanavir with ritonavir or COBI ^a Darunavir with ritonavir or COBI ^a Lopinavir with ritonavir
DESCOVY 200/25 mg once daily	Dolutegravir, efavirenz, maraviroc, nevirapine, rilpivirine, raltegravir

a Atazanavir with COBI and darunavir with COBI were not evaluated in Study GS-US-311-1089 (see **DRUG INTERACTIONS**).

For specific dosing recommendations for coadministered antiretroviral agents, refer to their respective Product Monograph.

Pediatrics (weighing <25 kg)

DESCOVY is not indicated for use in pediatric patients weighing <25 kg.

Geriatrics (≥65 years of age)

No dose adjustment is required for elderly patients. No differences in safety or efficacy have been observed between elderly patients and those <65 years of age.

Renal Impairment

No dose adjustment of DESCOVY is required in adult patients with estimated creatinine clearance ≥30 mL per minute. The safety of DESCOVY has not been established in patients with estimated creatinine clearance that declines below 30 mL per minute.

DESCOVY should not be initiated in patients with estimated creatinine clearance below 30 mL per minute as there are insufficient data available regarding the use of DESCOVY in this population.

DESCOVY is not recommended in pediatric patients with renal impairment as no data are available in this population.

Hepatic Impairment

No dose adjustment of DESCOVY is required in patients with hepatic impairment. (see **ACTION AND CLINICAL PHARMACOLOGY**).

4.3 Missed Dose

If a patient misses a dose of DESCOVY within 18 hours of the time it is usually taken, the patient should take DESCOVY with or without food as soon as possible, and then take the next dose of DESCOVY at the regularly scheduled time.

If a patient misses a dose of DESCOVY by more than 18 hours, the patient should not take the missed dose, but resume the usual dosing schedule.

5 OVERDOSAGE

For management of a suspected drug overdose, contact your regional Poison Control Centre.

If overdose occurs the patient must be monitored for evidence of toxicity. Treatment of overdose with DESCOVY consists of general supportive measures including monitoring of vital signs as well as observation of the clinical status of the patient.

Emtricitabine

Limited clinical experience is available at doses higher than the therapeutic dose of FTC. In one clinical pharmacology study, single doses of FTC 1200 mg (6 times the dose in DESCOVY) were administered to 11 subjects. No severe adverse reactions were reported. The effects of higher doses are not known.

Emtricitabine can be removed by hemodialysis, which removes approximately 30% of the FTC dose over a 3 hour dialysis period starting within 1.5 hours of FTC dosing.

It is not known whether FTC can be removed by peritoneal dialysis.

Tenofovir Alafenamide

Limited clinical experience is available at doses higher than the therapeutic dose of TAF. A single suprathereapeutic dose of 125 mg TAF was administered to 48 healthy subjects. No serious adverse reactions were reported. The effects of higher doses are unknown. Tenofovir is efficiently removed by hemodialysis with an extraction coefficient of approximately 54%.

6 DOSAGE FORMS, STRENGTHS, COMPOSITION AND PACKAGING

DESCOVY is available as rectangular-shaped, film-coated tablets containing 200 mg of FTC and either 10 mg or 25 mg of TAF (grey tablets and blue tablets, respectively). Each tablet is debossed with “GSI” on one side and either “210” (200/10 mg strength) or “225” (200/25 mg strength) on the other side. Each bottle contains 30 tablets and a silica gel desiccant and is closed with a child-resistant closure.

The tablets include the following inactive ingredients: microcrystalline cellulose, croscarmellose sodium, and magnesium stearate. The grey tablets are film-coated with a coating material containing polyvinyl alcohol, titanium dioxide, polyethylene glycol, talc, and iron oxide black. The blue tablets are film-coated with a coating material containing polyvinyl alcohol, titanium dioxide, polyethylene glycol, talc, and indigo carmine aluminum lake.

7 WARNINGS AND PRECAUTIONS

Please see the **SERIOUS WARNINGS AND PRECAUTIONS BOX** at the beginning of Part I: Health Professional Information.

General

DESCOVY is a fixed dose combination (FDC) of FTC and TAF.

DESCOVY should not be used alone and should be administered in combination with other antiretrovirals such as non-nucleoside reverse transcriptase inhibitors, protease inhibitors, or integrase inhibitors.

In the presence of a pharmacokinetic enhancer (i.e., ritonavir or cobicistat (COBI)), the dose of DESCOVY should be 200 mg/10 mg (FTC/TAF).

DESCOVY should not be coadministered with products containing any of the same components, FTC or TAF (ATRIPLA[®], BIKTARVY[®], COMPLERA[®], EMTRIVA[®],

GENVOYA[®], ODEFSEY[®], STRIBILD[®], Symtuza[™], TRUVADA[®], and VEMLIDY[™]); or with products containing lamivudine (3TC[®], Combivir[®], Kivexa[®], Triumeq[®], and Trizivir[®]) or tenofovir disoproxil fumarate (TDF) (ATRIPLA[®], COMPLERA[®], STRIBILD[®], TRUVADA[®], and VIREAD[®]); and DESCOVY should not be administered with adefovir dipivoxil (HEPSERA[®]).

DESCOVY is not indicated for use as a pre-exposure prophylaxis (PrEP) to reduce the risk of sexually acquired HIV-1 in adults at high-risk.

Triple nucleoside regimens are not recommended.

The safety and efficacy of DESCOVY has not been established in patients with virologic failure.

In treatment-experienced patients, the use of DESCOVY should be guided by laboratory testing and treatment history.

Endocrine and Metabolism

Serum Lipids and Blood Glucose

Serum lipid and blood glucose levels may increase during antiretroviral therapy. Disease control and life style changes may also be contributing factors. Consideration should be given to the measurement of serum lipids and blood glucose. Lipid disorders and blood glucose elevations should be managed as clinically appropriate.

Hepatic/Biliary/Pancreatic

Hepatic Impairment

Tenofovir and TAF are not metabolized by liver enzymes. Clinically relevant pharmacokinetic changes in patients with hepatic impairment were not observed. Therefore, no dose adjustment of DESCOVY is required in patients with hepatic impairment. FTC has not been evaluated in patients with hepatic impairment; however, FTC is not significantly metabolized by liver enzymes, so the impact of liver impairment is likely to be limited.

The safety and efficacy of DESCOVY have not been studied specifically in patients with underlying liver disorders. Patients with chronic hepatitis B or C who are treated with ART are at increased risk for severe and potentially fatal hepatic adverse events (see **WARNINGS AND PRECAUTIONS, Special Populations**).

Lactic Acidosis/Severe Hepatomegaly with Steatosis

Lactic acidosis and severe hepatomegaly with steatosis, including fatal cases, have been reported with the use of nucleoside analogs, including FTC, a component of DESCOVY, and TDF, another prodrug of tenofovir, alone or in combination with other

antiretrovirals. Treatment with DESCOVY should be suspended in any patient who develops clinical or laboratory findings suggestive of lactic acidosis or pronounced hepatotoxicity (which may include hepatomegaly and steatosis even in the absence of marked transaminase elevations).

Pancreatitis

Caution should be exercised in the use of DESCOVY in patients with a history of pancreatitis or risk factors for the development of pancreatitis. Pancreatitis has occurred during the use of nucleoside analogues. Therapy should be suspended in patients with suspected pancreatitis.

Immune

Immune Reconstitution Inflammatory Syndrome

Immune reconstitution inflammatory syndrome has been reported in patients treated with combination ART, including FTC, a component of DESCOVY. During the initial phase of combination antiretroviral treatment, patients whose immune system responds may develop an inflammatory response to indolent or residual opportunistic infections [such as *Mycobacterium avium* infection, cytomegalovirus, *Pneumocystis jirovecii* pneumonia (PCP), or tuberculosis], which may necessitate further evaluation and treatment.

Autoimmune disorders (such as Graves' disease, polymyositis, Guillain-Barré syndrome, and autoimmune hepatitis) have also been reported to occur in the setting of immune reconstitution, however, the time to onset is more variable, and can occur many months after initiation of treatment.

Musculoskeletal

Bone Effects

Tenofovir alafenamide and tenofovir have been shown to be associated with decreases in bone mineral density (BMD) in animal toxicology studies and in human clinical trials.

In a pooled analysis of two Phase 3 clinical studies in HIV-1 infected ART treatment-naïve adults who received FTC+TAF in combination with elvitegravir (EVG) and COBI as a FDC tablet, the percentage of patients who had more than a 3% decrease from baseline in hip and spine BMD at Week 48 was 17% and 27%, respectively, at Week 96 was 23% and 26%, respectively, and at Week 144 was 28% and 30%, respectively (see **CLINICAL TRIALS**).

The effects of TAF-associated changes in BMD and biochemical markers on long-term bone health and future fracture risk are unknown.

Renal

Renal impairment, including cases of acute renal failure and Fanconi syndrome (renal tubular injury with severe hypophosphatemia), has been reported with the use of tenofovir prodrugs in both animal toxicology studies and human trials. In clinical trials with EVG/COBI/FTC/TAF, there have been no cases of Fanconi syndrome or proximal renal tubulopathy.

Patients taking tenofovir prodrugs who have impaired renal function and those taking nephrotoxic agents including non-steroidal anti-inflammatory drugs are at increased risk of developing renal-related adverse reactions.

7.1 Special Populations

7.1.1 Patients Coinfected with HIV and HBV

The safety and efficacy of DESCOVY have not been established in patients coinfecting with HIV-1 and HBV. It is recommended that all patients with HIV-1 be tested for hepatitis B virus (HBV) before or when initiating ART.

Severe acute exacerbations of hepatitis B (and associated with liver decompensation and liver failure in some patients) may occur in patients coinfecting with HBV and HIV-1 after discontinuation of FTC and TAF, the two components of DESCOVY.

Hepatic function should be closely monitored with both clinical and laboratory follow-up for at least several months in patients who discontinue DESCOVY and are coinfecting with HIV-1 and HBV. If appropriate, initiation of anti-hepatitis B therapy may be warranted. In patients with advanced liver disease or cirrhosis, post-treatment exacerbation of hepatitis may lead to hepatic decompensation and liver failure. Therefore, in these patients, discontinuation of treatment without initiation of alternative anti-hepatitis B therapy is not recommended.

7.1.2 Pregnant Women

DESCOVY has not been studied in pregnant women. DESCOVY should not be used in pregnant women unless the potential benefits outweigh the potential risks to the fetus.

In the embryo-fetal development study in rats, administration of TAF was associated with reduced fetal body weight and delayed ossification rate at ≥ 100 mg/kg. The no-observed-adverse-effect-level (NOAEL) for embryo-fetal development was 25 mg/kg (approximately 10 times the clinical tenofovir exposure based on AUC).

In the embryo-fetal toxicity study in pregnant rabbits, administration of TAF resulted in significantly increased number of litters with minor external and visceral anomalies at 100 mg/kg (approximately 90 times the clinical tenofovir exposure based on AUC). The NOAEL for embryo-fetal development was 30 mg/kg/day (approximately 17 times the clinical tenofovir exposure based on AUC).

In the peri- and postnatal development study, administration of TDF, another prodrug of tenofovir, to pregnant rats resulted in increased peri/postpartum pup mortality, reduced pup survival, reduced pup body weights, reduced survival of F1 generation, reduced body weight/food consumption of F1 generation and delayed sexual maturation of F1 generation at ≥ 400 mg/kg (approximately 90 times the clinical tenofovir exposure based on AUC). The NOAEL for these effects was 150 mg/kg (approximately 25 times the clinical tenofovir exposure based on AUC). These results are considered relevant to TAF.

Antiretroviral Pregnancy Registry: To monitor fetal outcomes of pregnant women exposed to ART including DESCOVY, an Antiretroviral Pregnancy Registry has been established. Healthcare providers are encouraged to register patients,
<http://www.apregistry.com>
Telephone: (800) 258-4263
Fax: (800) 800-1052

7.1.3 Nursing Women

HIV-1 infected mothers should not breastfeed their infants to avoid risking postnatal transmission of HIV. Studies in rats have demonstrated that tenofovir is secreted into milk. It is not known whether TAF is excreted in human milk. Tenofovir-associated risks, including the risk of developing viral resistance to tenofovir, in infants breastfed by mothers being treated with TAF are unknown.

In humans, samples of breast milk obtained from five HIV-1 infected mothers show that FTC is secreted in human milk at estimated neonatal concentrations 3 to 12 times higher than the FTC IC₅₀ but 3 to 12 times lower than the C_{min} achieved from oral administration of FTC. Breastfeeding infants whose mothers are being treated with FTC may be at risk for developing viral resistance to FTC. Other FTC-associated risks in infants breastfed by mothers being treated with FTC are unknown.

Because of both the potential for HIV transmission and the potential for serious adverse reactions in nursing infants, **mothers should be instructed not to breastfeed if they are receiving DESCOVY.**

7.1.4 Pediatrics (weighing <25 kg)

Safety and efficacy of DESCOVY in children weighing less than 25 kg have not been established.

7.1.5 Geriatrics (≥ 65 years of age):

No dose adjustment of DESCOVY is required for elderly patients. In clinical trials, 80 of the 97 patients enrolled aged 65 years and over received FTC+TAF given with EVG+COBI as a FDC tablet (administered as GENVOYA). No differences in safety or

efficacy have been observed between elderly patients and those <65 years of age (see **ACTION and CLINICAL PHARMACOLOGY**).

8 ADVERSE REACTIONS

8.1 Adverse Reaction Overview

The safety of DESCOVY is based on studies of FTC+TAF when given with EVG+COBI as the FDC tablet, GENVOYA (EVG/COBI/FTC/TAF).

The following adverse drug reactions are discussed in other sections of the product monograph:

- Severe Acute Exacerbations of Hepatitis B [see **SERIOUS WARNINGS AND PRECAUTIONS BOX**]
- Immune Reconstitution Inflammatory Syndrome [see **WARNINGS AND PRECAUTIONS**].
- Lactic Acidosis/Severe Hepatomegaly with Steatosis [See **WARNINGS AND PRECAUTIONS**]

8.2 Clinical Trial Adverse Drug Reactions

Because clinical trials are conducted under very specific conditions, the adverse reaction rates observed in the clinical trials may not reflect the rates observed in practice and should not be compared to the rates in the clinical trials of another drug. Adverse drug reaction information from clinical trials is useful for identifying drug-related adverse events and for approximating rates.

Clinical Trials in Treatment-Naïve Adults

The safety assessment of FTC and TAF is based on Weeks 48, 96, and 144 pooled data from 1733 patients in two comparative clinical trials, GS-US-292-0104 (Study 104) and GS-US-292-0111 (Study 111), in antiretroviral treatment-naïve HIV-1 infected adult patients who received FTC+TAF (N=866) given with EVG+COBI as a FDC tablet (administered as GENVOYA) once daily.

The proportion of patients who discontinued treatment with FTC+TAF (administered as GENVOYA) or FTC+TDF (administered as STRIBILD) due to adverse events, regardless of severity, was 0.9% and 1.5% at Week 48 and 1.3% and 3.3% at Week 144, respectively. Table 2 displays the frequency of adverse reactions (Grades 2-4) greater than or equal to 1%, respectively.

Table 2. Adverse Drug Reactions^a (Grades 2-4) Reported in \geq 1% of HIV-1 Infected Treatment-Naïve Adults Receiving FTC+TAF (administered as GENVOYA) in Studies GS-US-292-0104 and GS-US-292-0111 (Week 48 and Week 144 Analyses^b)

	Week 48 and Week 144	
	FTC+TAF (Administered as GENVOYA) (N=866)	FTC+TDF (Administered as STRIBILD) (N=867)
GASTROINTESTINAL DISORDERS		
Nausea	1%	1%
Diarrhea	1%	<1%
GENERAL DISORDERS AND ADMINISTRATION SITE CONDITIONS		
Fatigue	1%	1%
NERVOUS SYSTEM DISORDERS		
Headache	1%	1%

FTC=emtricitabine; TAF= tenofovir alafenamide; TDF= tenofovir disoproxil fumarate

a Frequencies of adverse reactions are based on Grades 2-4 adverse events attributed to study drugs by the investigator.

b Frequencies of adverse reactions at Week 48 and at Week 144 were the same.

8.3 Less Common Clinical Trial Adverse Drug Reactions (<1%)

In addition to the adverse reactions presented in Table 1, abdominal pain, dyspepsia, flatulence, rash, and vomiting occurred at a frequency of <1% and/or at severity of Grade 1 in the FTC+TAF group (administered as GENVOYA).

Adverse Reactions from Clinical Trials of the Components of DESCOVY

For information on the safety profile of FTC, consult the Product Monograph for EMTRIVA.

8.4 Laboratory Abnormalities

The frequency of laboratory abnormalities (Grades 3-4) occurring in at least 2% of patients receiving FTC+TAF given with EVG+COBI as a FDC tablet (administered as GENVOYA) in Studies 104 and 111 are presented in Table 3.

Table 3. Laboratory Abnormalities (Grades 3-4) Reported in \geq 2% of Patients Receiving FTC+TAF (administered as GENVOYA) in Studies GS-US-292-0104 and GS-US-292-0111 (Week 48 and Week 144 Analyses)

Laboratory Parameter Abnormality ^a	Week 48		Week 144	
	FTC+TAF (Administered as GENVOYA) (N=866)	FTC+TDF (Administered as STRIBILD) (N=867)	FTC+TAF (Administered as GENVOYA) (N=866)	FTC+TDF (Administered as STRIBILD) (N=867)
Amylase (> 2.0 x ULN)	<2%	3%	3%	5%
ALT (> 5.0 x ULN)	<2%	<2%	3%	3%
AST (>5.0 x ULN)	<2%	<2%	3%	4%
Creatine Kinase (\geq 10.0 x ULN)	7%	6%	11%	10%
LDL-cholesterol (fasted) (>4.92mmol/L)	5%	2%	11%	5%
Total Cholesterol (fasted) (>7.77 mmol/L)	<2%	1%	4%	3%
Lipase ^b (\geq 3.0 x ULN)	4%	8%	5%	8%
Urine RBC (Hematuria) (>75 RBC/HPF)	<2%	2%	3%	3%

FTC=emtricitabine; TAF= tenofovir alafenamide; TDF= tenofovir disoproxil fumarate

a Frequencies are based on treatment-emergent laboratory abnormalities.

b Lipase test was performed only for patients with serum amylase >1.5 x ULN (N=90 for GENVOYA arm, N=113 for STRIBILD arm at Week 48; N=127 for GENVOYA arm, N=154 for STRIBILD arm at Week 144).

Serum Lipids

Patients receiving FTC+TAF (administered as GENVOYA) experienced higher increases in serum lipids than those receiving FTC+TDF (administered as STRIBILD). In the clinical trials of FTC+TAF and of FTC+TDF, both given with EVG+COBI as a FDC tablet (administered as GENVOYA and STRIBILD, respectively), a similar percentage of patients receiving FTC+TAF and FTC+TDF were on lipid lowering agents at baseline (2% and 3%, respectively). Similar percentages of subjects in each treatment group initiated lipid-modifying medications through Week 144, 5.5% and 5.8% in subjects FTC+TAF and FTC+TDF, respectively.

Changes from baseline in total cholesterol, HDL-cholesterol, LDL-cholesterol, triglycerides and total cholesterol to HDL ratio at Week 48 and Week 144 are presented in Table 4.

Table 4. Lipid Values, Mean Change from Baseline, Reported in Patients Receiving FTC+TAF (Administered as GENVOYA) or FTC+TDF (Administered as STRIBILD) in Studies GS-US-292-0104 and GS-US-292-0111^a (Week 48 and Week 144 Analyses)

	Week 48				Week 144			
	FTC+TAF (Administered as GENVOYA) N=866		FTC+TDF (Administered as STRIBILD) N=867		FTC+TAF (Administered as GENVOYA) N=866		FTC+TDF (Administered as STRIBILD) N=867	
	Baseline	Change ^b at Week 48	Baseline	Change ^b at Week 48	Baseline	Change ^c at Week 144	Baseline	Change ^c at Week 144
Total Cholesterol (fasted), mmol/L	4.19 [N=757]	+0.78 [N=757]	4.29 [N=742]	+0.04 [N=742]	4.19 [N=647]	+0.80 [N=647]	4.27 [N=627]	+0.36 [N=627]
HDL-cholesterol (fasted), mmol/L	1.19 [N=757]	+0.18 [N=757]	1.16 [N=742]	+0.10 [N=742]	1.21 [N=647]	+0.18 [N=647]	1.19 [N=627]	+0.08 [N=627]
LDL-cholesterol (fasted), mmol/L	2.69 [N=753]	+0.39 [N=753]	2.77 [N=744]	+0.08 [N=744]	2.66 [N=643]	+0.52 [N=643]	2.77 [N=628]	+0.21 [N=628]
Triglycerides (fasted), mmol/L	1.28 [N=757]	+0.33 [N=757]	1.34 [N=742]	+0.11 [N=742]	1.25 [N=647]	+0.33 [N=647]	1.30 [N=627]	+0.19 [N=627]
Total Cholesterol to HDL ratio	3.7 [N=757]	0.2 [N=757]	3.9 [N=742]	0 [N=742]	3.7 [N=647]	0.2 [N=647]	3.8 [N=627]	0.1 [N=627]

FTC=emtricitabine; TAF= tenofovir alafenamide; TDF= tenofovir disoproxil fumarate

a Excludes patients who received lipid lowering agents during the treatment period.

b The change from baseline is the mean of within patient changes from baseline for patients with both baseline and Week 48 values.

c The change from baseline is the mean of within patient changes from baseline for patients with both baseline and Week 144 values.

8.5 Clinical Trials in Virologically Suppressed Patients

No new adverse reactions to DESCOVY were identified through Week 96 in the double-blind clinical study GS-US-311-1089 of virologically suppressed patients who changed their background regimen from TRUVADA to DESCOVY while maintaining their third antiretroviral agent (N=333).

8.6 Clinical Trials in Adult Patients with Renal Impairment

The safety of FTC+TAF was evaluated through Week 144 in an open-label clinical study GS-US-292-0112 (Study 112) in which 248 HIV-1 infected patients with mild to moderate renal impairment (estimated CrCl by Cockcroft-Gault method 30-69 mL/min) received FTC+TAF in combination with EVG+COBI as a FDC tablet (administered as GENVOYA). The safety profile of FTC+TAF in patients with mild to moderate renal impairment was similar to that in patients with normal renal function (estimated CrCl \geq 80 mL/min). The safety results were consistent through Week 144 (see **CLINICAL TRIALS**).

8.7 Clinical Trials in Pediatric Patients (6 to <18 years of age)

The safety of FTC+TAF was evaluated in 50 HIV-1 infected, treatment-naïve pediatric patients between the ages of 12 to <18 years (\geq 35 kg) through Week 48 in Cohort 1, and in 23 virologically suppressed pediatric patients between the ages of 6 to <12 years (\geq 25 kg) through Week 24 in Cohort 2 of an open-label clinical trial GS-US-292-0106 (Study 106) where patients received FTC+TAF administered in combination with EVG+COBI as a FDC tablet (administered as GENVOYA) (see **CLINICAL TRIALS**). In this study, the safety profile of DESCOVY in pediatric patients who received treatment with FTC+TAF was similar to that in adults.

One 13 year old female subject in Cohort 1 developed unexplained uveitis while receiving GENVOYA that resolved and did not require discontinuation of GENVOYA.

In Cohort 1 of Study 106, 4 patients experienced treatment-emergent worsening in the spine (N=39) and/or TBLH (N=37) height-age-adjusted BMD Z-score clinical status from baseline at Week 24, where a relationship to FTC and TAF could not be excluded. However, two of these patients subsequently showed improvements in BMD at Week 48. In Cohort 2 of Study 106, 2 patients had significant (at least 4%) lumbar spine BMD loss at Week 24 (see **WARNINGS AND PRECAUTIONS**).

Also within Cohort 2 of Study 106, although all subjects had HIV-1 RNA < 50 copies/mL, there was a decrease from baseline in mean CD4+ cell count at Week 24 (all subjects' CD4+ cell counts remained above 400 cells/mm³) (see **CLINICAL TRIALS, Study results**).

The mean baseline and mean change from baseline in CD4+ cell count and in CD4% from Week 2 to Week 24 are presented in Table 5.

Table 5. Mean Change in CD4+ Count and Percentage from Baseline to Week 24 in Virologically-Suppressed Pediatric Patients from 6 to <12 Years Who Switched to FTC+TAF (administered as GENVOYA)

	Baseline	Mean Change from Baseline			
		Week 2	Week 4	Week 12	Week 24
CD4+ Cell Count (cells/mm ³)	966 (201.7) ^a	-162	-125	-162	-150
CD4%	40 (5.3) ^a	+0.5%	-0.1%	-0.8%	-1.5%

a. Mean (SD)

8.8 Post-Market Adverse Drug Reactions

In addition to the adverse reaction reports from clinical trials, the following possible adverse reactions have been identified during post-approval use of products containing FTC or TAF. Because these events have been reported voluntarily from a population of unknown size, estimates of frequency cannot be made. These events have been considered possible adverse reactions due to a combination of their seriousness, frequency of reporting or potential causal relationship with treatment.

Emtricitabine

The following adverse experiences have been reported in post-marketing experience without regard to causality; some events represent a single report.

Blood and lymphatic system disorders: Thrombocytopenia

Gastrointestinal disorders: Pancreatitis

General disorders and administrative site conditions: Pyrexia

Metabolism and nutrition disorders: Lactic acidosis

Tenofovir Alafenamide

Skin and subcutaneous tissue disorders: Angioedema, urticaria

9 DRUG INTERACTIONS

9.1 Drug-Drug Interactions

Potential for Other Drugs to Affect One or More Components of DESCOVY

Emtricitabine

In vitro and clinical pharmacokinetic drug-drug interaction studies have shown that the potential for CYP-mediated interactions involving FTC with other medicinal products is low.

Emtricitabine is primarily excreted by the kidneys by a combination of glomerular filtration and active tubular secretion. No drug-drug interactions due to competition for renal excretion have been observed; however, coadministration of FTC with drugs that are eliminated by active tubular secretion may increase concentrations of FTC, and/or the coadministered drug.

Drugs that decrease renal function may increase concentrations of FTC.

Tenofovir Alafenamide

Tenofovir alafenamide, a component of DESCOVY, is a substrate of P-glycoprotein (P-gp), and breast cancer resistance protein (BCRP). Drugs that strongly affect P-gp and BCRP activity may lead to changes in TAF absorption (see Table 6). Drugs that induce P-gp activity are expected to decrease the absorption of TAF, resulting in decreased plasma concentration of TAF, which may lead to loss of therapeutic effect of DESCOVY and development of resistance.

Coadministration of DESCOVY with other drugs that inhibit P-gp or BCRP may increase the absorption and plasma concentration of TAF.

In vitro and clinical pharmacokinetic drug-drug interactions studies have shown that the potential for CYP-mediated interactions involving TAF with other medicinal products is low.

Coadministration of DESCOVY with drugs that inhibit the lysosomal carboxypeptidase cathepsin A may decrease metabolism of TAF to tenofovir in target cells, which may lead to reduced therapeutic effect of DESCOVY and development of resistance (see **DRUG INTERACTIONS**, Table 6).

Established and Other Potentially Significant Interactions

DESCOVY should not be coadministered with products containing any of the same components, FTC or TAF; or with products containing lamivudine or TDF; and DESCOVY should not be administered with adefovir dipivoxil (see **WARNINGS AND PRECAUTIONS, General**).

Table 6 provides a listing of established or potentially clinically significant drug interactions. The drug interactions described are based on studies conducted with either DESCOVY, the components of DESCOVY (FTC and TAF) as individual agents, or are predicted drug interactions that may occur with DESCOVY. The table includes potentially significant interactions but is not all inclusive.

Table 6. Established and Other Potentially Significant^a Drug Interactions

Concomitant Drug Class: Drug Name	Effect on Concentration ^b	Clinical Comment
Antiretroviral Agents: Protease Inhibitors (PI)		
Atazanavir/cobicistat ^c	↑ tenofovir alafenamide	TAF exposure is increased when atazanavir/COBI is used in combination with DESCOVY. The recommended dose of DESCOVY is 200/10 mg once daily.
Atazanavir/ritonavir ^c	↑ tenofovir alafenamide	TAF exposure is increased when atazanavir/ritonavir is used in combination with DESCOVY. The recommended dose of DESCOVY is 200/10 mg once daily.
Darunavir/cobicistat ^c	↔ tenofovir alafenamide ↑ tenofovir ^d	Tenofovir ^d exposure is increased when darunavir/COBI is used in combination with DESCOVY. The recommended dose of DESCOVY is 200/10 mg once daily TAF exposure is not impacted.
Darunavir/ritonavir ^c	↔ tenofovir alafenamide ↑ tenofovir ^d	Tenofovir ^d exposure is increased when darunavir/ritonavir is used in combination with DESCOVY. The recommended dose of DESCOVY is 200/10 mg once daily. TAF exposure is not impacted.
Lopinavir/ritonavir ^c	↑ tenofovir alafenamide	TAF exposure is increased when lopinavir/ritonavir is used in combination with DESCOVY. The recommended dose of DESCOVY is 200/10 mg once daily.
Tipranavir/ritonavir	↓ tenofovir alafenamide	TAF exposure may decrease when tipranavir/ritonavir is used in combination with DESCOVY. There are no data available to make dosing recommendations. Coadministration with DESCOVY is not recommended.

Concomitant Drug Class: Drug Name	Effect on Concentration^b	Clinical Comment
Other Protease Inhibitors	Effect is unknown	There are no data available to make dosing recommendations for coadministration with other protease inhibitors.
Other Agents		
Anticonvulsants: carbamazepine ^c oxcarbazepine phenobarbital phenytoin	↓ tenofovir alafenamide	Coadministration of carbamazepine, oxcarbazepine, phenobarbital, or phenytoin, all of which are P-gp inducers, may decrease TAF plasma concentrations, which may result in loss of therapeutic effect and development of resistance. Alternative anticonvulsants should be considered.
Antifungals: itraconazole ketoconazole	↑ tenofovir alafenamide	Coadministration of itraconazole or ketoconazole, both of which are P-gp inhibitors, may increase plasma concentrations of TAF. No dose adjustment is required.
Antimycobacterial: rifabutin rifampin rifapentine*	↓ tenofovir alafenamide	Coadministration of rifampin, rifabutin, and rifapentine, all of which are P-gp inducers, may decrease TAF plasma concentrations, which may result in loss of therapeutic effect and development of resistance. Coadministration of DESCOVY with rifabutin, rifampin, or rifapentine* is not recommended.
Herbal Products: St. John's wort (<i>Hypericum perforatum</i>)	↓ tenofovir alafenamide	Coadministration of St. John's wort, a P-gp inducer, may decrease TAF plasma concentrations, which may result in loss of therapeutic effect and development of resistance. Coadministration of DESCOVY with St. John's wort is not recommended.

TAF = tenofovir alafenamide

* Not marketed in Canada

a This table is not all inclusive.

b ↑ = increase, ↓ = decrease ↔ = no effect

c Indicates that a drug-drug interaction study was conducted.

d Tenofovir is the major circulating metabolite of tenofovir alafenamide (see **ACTION AND CLINICAL PHARMACOLOGY**).

Drugs without Clinically Significant Interactions with DESCOVY

Based on drug interaction studies conducted with the components of DESCOVY, no clinically significant drug interactions have been either observed or are expected when DESCOVY is combined with the following antiretroviral agents: dolutegravir, efavirenz, famciclovir, ledipasvir/sofosbuvir, maraviroc, nevirapine, raltegravir, rilpivirine, sofosbuvir, sofosbuvir/velpatasvir, and sofosbuvir/velpatasvir/voxilaprevir. No clinically significant drug interactions have been either observed or expected when DESCOVY is combined with the following drugs: buprenorphine, ethinyl estradiol, methadone, midazolam, naloxone, norbuprenorphine, norgestimate, and sertraline.

Assessment of Drug Interactions

Drug Interaction Studies

Drug-drug interaction studies were conducted with DESCOVY or the components of DESCOVY (FTC or TAF) as individual agents.

The effects of coadministered drugs on the exposure of TAF are shown in Table 7. The effects of TAF on the exposure of coadministered drugs are shown in Table 8.

Table 7. Drug Interactions: Changes in Pharmacokinetic Parameters for TAF in the Presence of the Coadministered Drug^a

Coadministered Drug	Dose of Coadministered Drug (mg)	TAF (mg)	N	Percent Change of TAF Pharmacokinetic Parameters (90% CI) ^b ; No Effect = 0%		
				C _{max}	AUC	C _{min}
Atazanavir	300 + 100 ritonavir once daily	10 once daily	10	↑ 77% (↑ 28%, ↑ 144%)	↑ 91% (↑ 55%, ↑ 135%)	NA
Atazanavir	300 + 150 cobicistat once daily	10 once daily	20	↑ 80% (↑ 48%, ↑ 118%)	↑ 75% (↑ 55%, ↑ 98%)	NA
Carbamazepine	300 twice daily	25 once daily ^c	26	↓ 57% (↓ 64%, ↓ 49%)	↓ 55% (↓ 60%, ↓ 49%)	NA
Cobicistat	150 once daily	8 once daily	12	↑ 183% (↑ 120%, ↑ 265%)	↑ 165% (↑ 129%, ↑ 207%)	NA
Darunavir	800 + 150 cobicistat once daily	25 once daily ^c	11	↓ 7% ^d (↓ 28%, ↑ 21%)	↓ 2% ^d (↓ 20%, ↑ 19%)	NA
Darunavir	800 + 100 ritonavir once daily	10 once daily	10	↑ 42% ^e (↓ 4%, ↑ 109)	↑ 6% ^e (↓ 16%, ↑ 35%)	NA
Dolutegravir	50 once daily	10 once daily	10	↑ 24% (↓ 12%, ↑ 74%)	↑ 19% (↓ 4%, ↑ 48%)	NA
Efavirenz	600 once daily	40 once daily ^c	11	↓ 22% (↓ 42%, ↑ 5%)	↓ 14% (↓ 28%, ↑ 2%)	NA
Ledipasvir/ sofosbuvir	90/400 once daily	10 once daily ^f	30	↓ 10% (↓ 27%, ↑ 11%)	↓ 14% (↓ 22%, ↓ 5%)	NA
Ledipasvir/ sofosbuvir	90/400 once daily	25 once daily ^g	42	↑ 3% (↓ 6%, ↑ 14%)	↑ 32% (↑ 25%, ↑ 40%)	NA
Lopinavir	800 + 200 ritonavir once daily	10 once daily	10	↑ 119% (↑ 72%, ↑ 179%)	↑ 47% (↑ 17%, ↑ 85%)	NA

DESCOVY (emtricitabine/tenofovir alafenamide*) tablets

*as tenofovir alafenamide hemifumarate

Product Monograph

Coadministered Drug	Dose of Coadministered Drug (mg)	TAF (mg)	N	Percent Change of TAF Pharmacokinetic Parameters (90% CI) ^b ; No Effect = 0%		
				C _{max}	AUC	C _{min}
Rilpivirine	25 once daily	25 once daily	17	↑ 1% (↓ 16%, ↑ 22%)	↑ 1% (↓ 6%, ↑ 9%)	NA
Sertraline	50 single dose	10 once daily ^f	19	0% (↓ 14%, ↑ 16%)	↓ 4% (↓ 11%, ↑ 3%)	NA
Sofosbuvir/ velpatasvir	400/100 once daily	10 once daily ^f	24	↓ 20% (↓ 32%, ↓ 6%)	↓ 13% (↓ 19%, ↓ 6%)	NA
Sofosbuvir/ velpatasvir/ voxilaprevir	400/100/100 + 100 voxilaprevir ^h once daily	10 once daily ^f	29	↓ 21% (↓ 32%, ↓ 8%)	↓ 7% (↓ 15%, ↑ 1%)	NA
Sofosbuvir/ velpatasvir/ voxilaprevir	400/100/100 + 100 voxilaprevir ^h once daily	25 once daily ^g	30	↑ 32% (↑ 17%, ↑ 48%)	↑ 52% (↑ 43%, ↑ 61%)	NA

NA=Not Available/Not Applicable

a All interaction studies conducted in healthy volunteers.

b All No Effect Boundaries are ↓ 30% -↑43% unless otherwise specified.

c Study conducted with DESCOVY (FTC/TAF) (FTC=emtricitabine; TAF=tenofovir alafenamide)

d Percent change of tenofovir PK parameters (90% CI) was ↑216% (↑200%, ↑233%) for C_{max}, ↑224% (↑202%, ↑247%) for AUC_{tau}, and ↑221% (↑190%, ↑254%) for C_{min}.e Percent change of tenofovir PK parameters (90% CI) was ↑142% (↑ 98%, ↑195%) for C_{max}, ↑ 105% (↑54%, ↑172%) for AUC_{inf}.

f Study conducted with GENVOYA.

g Study conducted with ODEFSEY.

h Study conducted with additional voxilaprevir 100 mg to achieve voxilaprevir exposures expected in HCV-infected patients.

Table 8. Drug Interactions: Changes in Pharmacokinetic Parameters for Coadministered Drug in the Presence of TAF or the Individual Components^a

Coadministered Drug	Dose of Coadministered Drug (mg)	TAF (mg)	N	Percent Change of Coadministered Drug Pharmacokinetic Parameters (90% CI) ^b ; No Effect = 0%		
				C _{max}	AUC	C _{min}
Atazanavir	300 + 100 ritonavir once daily	10 once daily	10	↓ 2% (↓ 11 %, ↑ 7%)	↓ 1% (↓ 4%, ↑ 1%)	0% (↓ 4%, ↑ 4%)
Atazanavir	300 + 150 cobicistat once daily	10 once daily	20	↓ 2% (↓ 6%, ↑ 2%)	↑ 6% (↑ 1%, ↑ 11%)	↑ 18% (↑ 6%, ↑ 31%)
Darunavir	800 + 150 cobicistat once daily	25 once daily ^c	11	↑ 2% (↓ 4%, ↑ 9%)	↓ 1% (↓ 8%, ↑ 7%)	↓ 3% (↓ 18%, ↑ 15%)
Darunavir	800 + 100 ritonavir once daily	10 once daily ^c	10	↓ 1% (↓ 9%, ↑ 8%)	↑ 1% (↓ 4%, ↑ 6%)	↑ 13% (↓ 5%, ↑ 34%)
Dolutegravir	50 once daily	10 once daily ^c	10	↑ 15% (↑ 4%, ↑ 27%)	↑ 2% (↓ 3%, ↑ 8%)	↑ 5% (↓ 3%, ↑ 13%)
Ledipasvir	90/400 once daily	10 once daily ^e	30	↑ 65 % (↑ 53 %, ↑ 78%)	↑ 79 % (↑ 64 %, ↑ 96%)	↑ 93% (↑ 74 %, ↑ 115%)
Sofosbuvir				↑ 28 % (↑ 13 %, ↑ 47%)	↑ 47 % (↑ 35 %, ↑ 59%)	NA
GS-331007 ^f				↑ 29 % (↑ 24 %, ↑ 35%)	↑ 48 % (↑ 44 %, ↑ 53%)	↑ 66 % (↑ 60 %, ↑ 73%)
Ledipasvir	90/400 once daily	25 once daily ^g	41	↑ 1 % (↓ 3 %, ↑ 5%)	↑ 2 % (↓ 3 %, ↑ 6%)	↑ 2 % (↓ 2 %, ↑ 7%)
Sofosbuvir				↓ 4 % (↓ 11 %, ↑ 4%)	↑ 5 % (↑ 1 %, ↑ 9%)	NA
GS-331007 ^f				↑ 8 % (↑ 5 %, ↑ 11%)	↑ 8 % (↑ 6 %, ↑ 10%)	↑ 10 % (↑ 7 %, ↑ 12%)
Lopinavir	800 + 200 ritonavir once daily	10 once daily ^c	10	0% (↓ 5%, ↑ 6%)	0% (↓ 8%, ↑ 9%)	↓ 2% (↓ 15%, ↑ 12%)
Midazolam ^d	2.5 single dose, orally	25 once daily	18	↑ 2% (↓ 8%, ↑ 13%)	↑ 13% (↑ 4 %, ↑ 23%)	NA
	1 single dose, IV			↓ 1% (↓ 11%, ↑ 11%)	↑ 8% (↑ 4%, ↑ 14%)	NA
Norelgestromin	norgestimate 0.180/0.215/	25 once daily ^c	15	↑ 17% (↑ 7%, ↑ 26%)	↑ 12% (↑ 7%, ↑ 17%)	↑ 16% (↑ 8%, ↑ 24%)

DESCOVY (emtricitabine/tenofovir alafenamide*) tablets

*as tenofovir alafenamide hemifumarate

Product Monograph

Coadministered Drug	Dose of Coadministered Drug (mg)	TAF (mg)	N	Percent Change of Coadministered Drug Pharmacokinetic Parameters (90% CI) ^b ; No Effect = 0%		
				C _{max}	AUC	C _{min}
Norgestrel	0.250 once daily / ethinyl estradiol 0.025 once daily			↑ 10% (↑ 2%, ↑ 18%)	↑ 9% (↑ 1%, ↑ 18%)	↑ 11% (↑ 3%, ↑ 20%)
Ethinyl estradiol				↑ 22% (↑ 15%, ↑ 29%)	↑ 11% (↑ 7%, ↑ 16%)	↑ 2% (↓ 8%, ↑ 12%)
Rilpivirine	25 once daily	25 once daily	16	↓ 7% (↓ 13%, ↓ 1%)	↑ 1% (↓ 4%, ↑ 6%)	↑ 13% (↑ 4%, ↑ 23%)
Sertraline	50 single dose	10 once daily ^e	19	↑ 14% (↓ 6%, ↑ 38%)	↓ 7% (↓ 23%, ↑ 13%)	NA
Sofosbuvir	400/100 once daily	10 once daily ^e	24	↑ 23% (↑ 7%, ↑ 42%)	↑ 37% (↑ 24%, ↑ 52%)	NA
GS-331007 ^f				↑ 29% (↑ 25%, ↑ 33%)	↑ 48% (↑ 43%, ↑ 53%)	↑ 58% (↑ 52%, ↑ 65%)
Velpatasvir				↑ 30% (↑ 17%, ↑ 45%)	↑ 50% (↑ 35%, ↑ 66%)	↑ 60% (↑ 44%, ↑ 78%)
Sofosbuvir	400/100/100 + 100 ^h once daily	10 once daily ^e	29	↑ 27% (↑ 9%, ↑ 48%)	↑ 22% (↑ 12%, ↑ 32%)	NA
GS-331007 ^f				↑ 28% (↑ 25%, ↑ 32%)	↑ 43% (↑ 39%, ↑ 47%)	NA
Velpatasvir				↓ 4% (↓ 11%, ↑ 4%)	↑ 16% (↑ 6%, ↑ 27%)	↑ 46% (↑ 30%, ↑ 64%)
Voxilaprevir				↑ 92% (↑ 63%, ↑ 126%)	↑ 171% (↑ 130%, ↑ 219%)	↑ 350% (↑ 268%, ↑ 450%)

DESCOVY (emtricitabine/tenofovir alafenamide*) tablets

*as tenofovir alafenamide hemifumarate

Product Monograph

Coadministered Drug	Dose of Coadministered Drug (mg)	TAF (mg)	N	Percent Change of Coadministered Drug Pharmacokinetic Parameters (90% CI) ^b ; No Effect = 0%		
				C _{max}	AUC	C _{min}
Sofosbuvir	400/100/100 + 100 ^h once daily	25 once daily ^g	30	↓ 5% (↓ 14%, ↑ 5%)	↑ 1% (↓ 3%, ↑ 6%)	NA
GS-331007 ^f				↑ 2% (↓ 2%, ↑ 6%)	↑ 4% (↑ 1%, ↑ 6%)	NA
Velpatasvir				↑ 5% (↓ 4%, ↑ 16%)	↑ 1% (↓ 6%, ↑ 7%)	↑ 1% (↓ 5%, ↑ 9%)
Voxilaprevir				↓ 4% (↓ 16%, ↑ 11%)	↓ 6% (↓ 16%, ↑ 5%)	↑ 2% (↓ 8%, ↑ 12%)

NA=Not Available/Not Applicable

a All interaction studies conducted in healthy volunteers

b All No Effect Boundaries are ↓30% -↑43% unless otherwise specified.

c Study conducted with DESCOVY (FTC/TAF) (FTC=emtricitabine; TAF=tenofovir alafenamide).

d A sensitive CYP3A4 substrate.

e Study conducted with GENVOYA.

f The predominant circulating metabolite of sofosbuvir.

g Study conducted with ODEFSEY.

h Study conducted with additional voxilaprevir 100 mg to achieve voxilaprevir exposures expected in HCV-infected patients.

9.2 Drug-Food Interactions

Emtricitabine

Relative to fasting conditions, the administration of TAF with a high fat meal (~800 kcal, 50% fat), resulted in a decrease in FTC C_{max} and AUC_{last} of 27% and 9%, respectively. These changes are not considered clinically meaningful. DESCOVY can be taken without regard to food.

Tenofovir Alafenamide

Relative to fasting conditions, the administration of DESCOVY with a high fat meal (~800 kcal, 50% fat) resulted in a decrease in TAF C_{max} (15-37%) and an increase in AUC_{last} (17-77%). These modest changes are not considered clinically meaningful.

DESCOVY can be taken without regard to food.

9.3 Drug-Herb Interactions

Coadministration of St. John's wort, a P-gp inducer, may decrease TAF plasma concentrations, which may result in loss of therapeutic effect and development of resistance.

Coadministration of DESCOVY with St. John's wort is not recommended.

9.4 Drug-Laboratory Interactions

Interactions of DESCOVY with laboratory tests have not been established.

10 ACTION AND CLINICAL PHARMACOLOGY

10.1 Mechanism of Action

DESCOVY is a FDC of antiviral drugs FTC and TAF.

Emtricitabine

Emtricitabine is a nucleoside analogue of 2'-deoxycytidine. Emtricitabine is phosphorylated by cellular enzymes to form FTC triphosphate. Emtricitabine triphosphate inhibits HIV replication through incorporation into viral DNA by the HIV reverse transcriptase, which results in DNA chain-termination.

Emtricitabine has activity that is specific to human immunodeficiency virus (HIV-1 and HIV-2) and hepatitis B virus.

Emtricitabine triphosphate is a weak inhibitor of mammalian DNA polymerases that include mitochondrial DNA polymerase γ and there was no evidence of toxicity to mitochondria *in vitro* and *in vivo*.

Tenofovir Alafenamide

Tenofovir alafenamide is a phosphoramidate prodrug of tenofovir (2'-deoxyadenosine monophosphate analogue) and differs from TDF which is another prodrug of tenofovir. Tenofovir alafenamide is permeable into cells and due to increased plasma stability, and intracellular activation through hydrolysis by cathepsin A, TAF is efficient in loading tenofovir into peripheral blood mononuclear cells (PBMCs) (including lymphocytes and other HIV target cells) and macrophages. Intracellular tenofovir is subsequently phosphorylated to the pharmacologically active metabolite tenofovir diphosphate. Tenofovir diphosphate inhibits HIV replication through incorporation into viral DNA by the HIV reverse transcriptase, which results in DNA chain-termination.

Tenofovir has activity that is specific to human immunodeficiency virus (HIV-1 and HIV-2). Tenofovir alafenamide displayed antiviral activity in cell culture against all HIV-1 groups. Tenofovir diphosphate is a weak inhibitor of mammalian DNA polymerases that include mitochondrial DNA polymerase γ . In the *in vitro* study, TAF did not significantly affect mitochondrial DNA in HepG2 cells.

10.2 Pharmacodynamics

Effects on Electrocardiogram

In a thorough QT/QTc study in 48 healthy patients, TAF at the therapeutic dose or at a supratherapeutic dose approximately 5 times the recommended therapeutic dose did

not affect the QT/QTc interval and did not prolong the PR interval. The effect of the other component, FTC, or the combination of FTC+ TAF on the QT interval is not known.

10.3 Pharmacokinetics

Comparative Bioavailability

The bioavailabilities of FTC and TAF from a single dose administration of DESCOVY (F/TAF) 200 mg/10 mg FDC tablet with concomitant administration of COBI 150 mg tablet and EVG 150 mg tablet or a single dose of GENVOYA (E/C/F/TAF) 150 mg/150 mg/200 mg/10 mg fixed dose combination tablet in healthy male and female subjects (N=100) under moderate fat, moderate calorie fed conditions were comparable.

The bioavailabilities of FTC and TAF from a single dose administration of DESCOVY (F/TAF) 200 mg/25 mg FDC tablet or a single dose of GENVOYA (E/C/F/TAF) 150 mg/150 mg/200 mg/10 mg fixed dose combination tablet in healthy male and female subjects (N=116) under moderate fat, moderate calorie fed conditions were comparable.

Absorption and Bioavailability

Following administration of FTC/TAF hemifumarate 200 mg/25 mg fixed dose combination tablets with a high fat, high calorie meal, there was a delay in the mean T_{max} for FTC by approximately 1 hour, and a decrease in AUC_T and C_{max} for FTC by approximately 9% and 26%, respectively when compared to administration under fasting conditions. For TAF, there was a delay in the mean T_{max} for TAF by approximately 0.5 hours, an increase in the AUC_T for TAF by approximately 74% and a decrease in C_{max} for TAF by approximately 10% when compared to administration under fasting conditions.

Distribution

Emtricitabine

In vitro binding of FTC to human plasma proteins is <4% and is independent of concentration over the range of 0.02 to 200 µg/mL. At peak plasma concentration, the mean plasma to blood drug concentration ratio was ~1.0 and the mean semen to plasma drug concentration ratio was ~4.0.

Tenofovir Alafenamide

The binding of tenofovir to human plasma proteins is <0.7% and is independent of concentration over the range of 0.01–25 µg/mL. The binding of TAF to human plasma proteins in samples collected during clinical studies was approximately 80%.

Metabolism

Emtricitabine

Emtricitabine is not significantly metabolized.

Tenofovir Alafenamide

Metabolism is a major elimination pathway for TAF in humans, accounting for >80% of an oral dose. *In vitro* studies have shown that TAF is metabolized to tenofovir (major metabolite) by cathepsin A in peripheral blood mononuclear cells (PBMCs) (including lymphocytes and other HIV target cells) and macrophages; and by carboxylesterase-1 in hepatocytes. Tenofovir alafenamide is a substrate of P-gp and BCRP transporters, and is minimally metabolized by CYP3A4. Upon coadministration with the moderate CYP3A inducer probe efavirenz, TAF exposure was unaffected.

In vivo, TAF is hydrolyzed within cells to form tenofovir (major metabolite), which is phosphorylated to the active metabolite, tenofovir diphosphate. In human clinical studies, a 10 mg oral dose of TAF in a FDC of EVG/COBI/FTC/TAF resulted in tenofovir diphosphate concentrations >4-fold higher in PBMCs and >90% lower concentrations of tenofovir in plasma as compared to a 300 mg oral dose of TDF in STRIBILD.

In vitro, TAF is not an inhibitor of CYP1A2, CYP2B6, CYP2C8, CYP2C9, CYP2C19, CYP2D6, or UGT1A1.

Tenofovir alafenamide is not an inhibitor or inducer of CYP3A *in vivo*.

Excretion

Emtricitabine

Emtricitabine is primarily excreted in the urine by a combination of glomerular filtration and active tubular secretion.

Tenofovir Alafenamide

Tenofovir alafenamide is eliminated following metabolism to tenofovir. Tenofovir is renally eliminated by both glomerular filtration and active tubular secretion. Tenofovir alafenamide and tenofovir have a median plasma half-life of 0.51 and 32.37 hours, respectively. Renal excretion of intact TAF is a minor pathway with less than 1% of the dose eliminated in urine. The pharmacologically active metabolite, tenofovir diphosphate, has a half-life of 150-180 hours within PBMCs.

Special Populations and Conditions

Pediatrics (≥6 to <18 years of age)

Exposures of FTC and TAF achieved in 24 pediatric patients aged 12 to <18 years (Study 106) were similar to exposures achieved in treatment-naïve adults.

Exposures of FTC and TAF achieved in 23 pediatric patients between the ages of 6 to <12 years (≥25 kg) (Study 106) were generally higher (20-80%) than exposures achieved in adults; however, the increase was not considered clinically relevant as the safety profiles were similar in adult and pediatric patients.

Geriatrics (≥65 years of age)

Pharmacokinetic-pharmacodynamic analysis of HIV-infected patients in Phase 2 and Phase 3 trials of FTC+TAF given with EVG+COBI as a FDC tablet (administered as GENVOYA) showed that within the age range studied (8 to 82 years), age did not have a clinically relevant effect on exposures of TAF.

Race

Emtricitabine: No pharmacokinetic differences due to race have been identified following the administration of FTC.

Tenofovir Alafenamide: Pharmacokinetics-pharmacodynamics analyses of TAF in HIV-1 infected patients indicated that race had no clinically relevant effect on the exposure of TAF.

Gender

No clinically relevant pharmacokinetic differences have been observed between men and women for FTC and TAF.

Hepatic Impairment

Emtricitabine: The pharmacokinetics of FTC has not been studied in patients with hepatic impairment; however, FTC is not significantly metabolized by liver enzymes, so the impact of liver impairment should be limited.

Tenofovir Alafenamide: Clinically relevant changes in the pharmacokinetics of TAF or its metabolite tenofovir were not observed in patients with mild, moderate, or severe hepatic impairment; no TAF dose adjustment is required in patients with hepatic impairment.

Renal Impairment

No clinically relevant differences in TAF or tenofovir pharmacokinetics were observed between healthy patients and patients with severe renal impairment (estimated

creatinine clearance <30 mL/min) in studies of TAF. There are no pharmacokinetic data on TAF in patients with estimated creatinine clearance <15 mL/min.

The safety, virologic, and immunologic responses of DESCOVY in HIV-1 infected patients with mild to moderate renal impairment (estimated CrCl by Cockcroft-Gault method 30-69 mL/min) were evaluated with FTC+TAF given with EVG+COBI as a FDC tablet (administered as GENVOYA) in an open-label trial, Study 112. The safety profile of DESCOVY in patients with mild to moderate renal impairment was similar to that in patients with normal renal function.

Hepatitis B and/or Hepatitis C Virus Coinfection

The pharmacokinetics of FTC and TAF have not been fully evaluated in patients coinfecting with hepatitis B and/or C virus.

11 STORAGE, STABILITY AND DISPOSAL

- Store below 30 °C (86 °F).
- Keep container tightly closed.
- Dispense only in original container.
- Do not use if seal over bottle opening is broken or missing.

12 SPECIAL HANDLING INSTRUCTIONS

There are no special handling instructions.

PART II: SCIENTIFIC INFORMATION

13 PHARMACEUTICAL INFORMATION

DESCOVY is a FDC tablet containing emtricitabine (FTC) and TAF hemifumarate. FTC is a synthetic nucleoside analog of cytidine. Tenofovir alafenamide, a nucleoside reverse transcriptase inhibitor (NRTI), is a prodrug of tenofovir converted *in vivo* to tenofovir, and acyclic nucleoside phosphonate (nucleotide) analog of adenosine 5'-monophosphate.

DESCOVY tablets are for oral administration. Each tablet contains 200 mg of FTC and either 10 mg or 25 mg of TAF (which is equivalent to 11.2 mg and 28.0 mg of TAF hemifumarate, respectively). The tablets include the following inactive ingredients: microcrystalline cellulose, croscarmellose sodium, and magnesium stearate. The 200/10 mg strength tablets are film-coated with a coating material containing polyvinyl alcohol, titanium dioxide, polyethylene glycol, talc, and iron oxide black. The 200/25 mg strength tablets are film-coated with a coating material containing polyvinyl alcohol, titanium dioxide, polyethylene glycol, talc, and indigo carmine aluminum lake.

Emtricitabine (FTC)

Drug Substance

Common Name: emtricitabine (USAN)

Chemical Name: 5-fluoro-1-(2R,5S)-[2-(hydroxymethyl)-1,3-oxathiolan-5-yl]cytosine

Empirical Formula: C₈H₁₀FN₃O₃S

Molecular Weight: 247.24

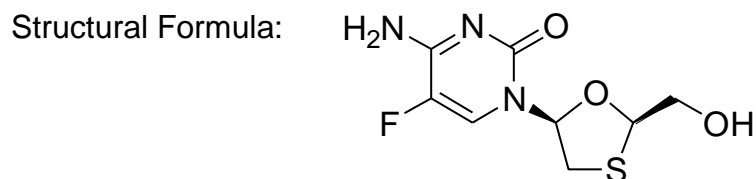

Physicochemical Properties:

Description: Emtricitabine is a white to off-white crystalline powder.

Solubility: The solubility is approximately 112 mg/mL in water at 25°C. The partition coefficient (log P) is -0.43 and the pKa is 2.65.

Tenofovir Alafenamide (TAF)

Drug Substance

Common Name: Tenofovir alafenamide hemifumarate
Tenofovir alafenamide fumarate (USAN)

Chemical Name: Propan-2-yl N-[(S)-({[(2R)-1-(6-amino-9H-purin-9-yl)propan-2-yl]-oxy)methyl](phenoxy)phosphoryl]-l-alaninate, (2E)-but-2-enedioate (2:1)

Empirical Formula: $C_{21}H_{29}O_5N_6P \cdot 1/2(C_4H_4O_4)$

Molecular Weight: 534.5

Structural Formula:

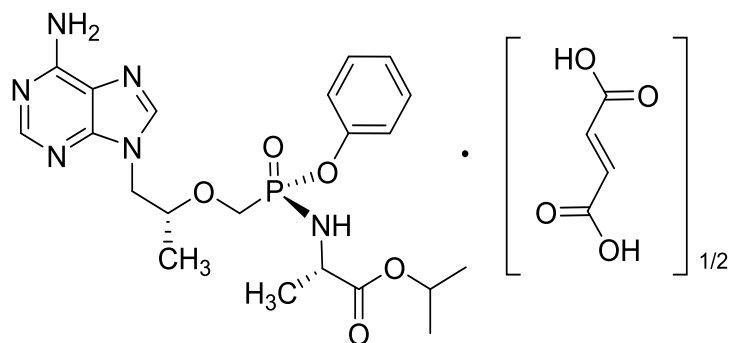

Physicochemical Properties:

Description: TAF hemifumarate is a white to off-white or tan powder.

Solubility: The solubility of TAF hemifumarate in water, pH 8.0 (50 mM phosphate buffer) at 20°C is 4.86 mg/mL. The partition coefficient (log P) is 1.6 and the pKa is 3.96.

14 CLINICAL TRIALS

14.1 Study Demographics and Trial Design

Description of Clinical Studies

The clinical efficacy of DESCOVY in treatment-naïve patients was established from studies conducted with FTC+TAF when given with EVG+COBI in a FDC (GENVOYA [E/C/F/TAF]). There are no efficacy and safety studies conducted in treatment-naïve patients with DESCOVY.

Pivotal Comparative Bioavailability Studies

Study GS-US-311-1472 was a randomized, open-label, single-dose, 2-way crossover study conducted in 100 healthy male and female subjects to compare the bioavailabilities of FTC and TAF from a single dose of DESCOVY (F/TAF) 200 mg/10 mg fixed dose combination tablet administered concomitantly with COBI 150 mg tablet and EVG 150 mg tablet, and a single dose of GENVOYA (E/C/F/TAF) 150/150/200/10 mg fixed dose combination tablet under moderate calorie, moderate fat fed conditions. A summary of the data is provided in Table 9.

Table 9. Summary Table of the Comparative Bioavailability Data for Study GS-US-311-1472

Emtricitabine (FTC)
(1 x 200 mg FTC/10 mg TAF hemifumarate + 150 mg EVG + 150 mg COBI or 1 x 150 mg EVG/150 mg COBI/200 mg FTC/ 10 mg TAF hemifumarate)

From measured data
Geometric Least Squares Mean
Arithmetic Mean (CV %)

Parameter	Test*	Reference†	% Ratio of Geometric Means	90% Confidence Interval
AUC _T (ng.h/mL)	9975.14 10159.2 (17.2)	9991.25 10086.8 (15.9)	99.84	98.41 – 101.29
AUC _{Inf} (ng.h/mL)	10259.33 10535.1 (27.0)	10191.26 10294.4 (15.8)	100.67	98.24 – 103.16
C _{max} (ng/mL)	1629.68 1660.8 (20.6)	1636.72 1662.6 (19.1)	99.57	96.78 – 102.44
T _{max} [§] (h)	2.02 (1.00 - 5.00)	2.00 (0.75 - 5.00)		
T _{1/2} ^ψ (h)	18.11 (46.8)	19.08 (57.0)		

Tenofovir alafenamide (TAF)
(1 x 200 mg FTC /10 mg TAF hemifumarate + 150 mg EVG + 150 mg COBI or 1 x 150 mg EVG /150 mg COBI /200 mg FTC / 10 mg TAF hemifumarate)

From measured data
Geometric Least Squares Mean
Arithmetic Mean (CV %)

Parameter	Test*	Reference†	% Ratio of Geometric Means	90% Confidence Interval
AUC _T (ng.h/mL)	317.27 335.7 (34.0)	323.89 342.5 (33.8 34.0)	97.96	94.69 – 101.34
AUC _{Inf} (ng.h/mL)	330.89 352.4 (30.8)	336.49 356.7 (33.2)	98.34	94.81 – 101.99
C _{max} (ng/mL)	267.18 299.4 (49.2)	275.85 311.7 (48.4)	96.86	89.36 – 104.99
T _{max} [§] (h)	1.50 (0.50 – 4.00)	1.02 (0.48 – 4.00)		
T _{1/2} ^ψ (h)	0.41 (39.5)	0.43 (35.4)		

* DESCOVY (200 mg FTC/10 mg TAF hemifumarate fixed dose combination tablet) + 150 mg COBI tablet + 150 mg EVG tablet administered under moderate fat, moderate calorie fed conditions.

† GENVOYA (EVG/COBI/FTC/TAF hemifumarate) 150 mg/150 mg/200 mg/10 mg fixed dose combination tablet administered under moderate fat, moderate calorie conditions.

DESCOVY (emtricitabine/tenofovir alafenamide*) tablets

*as tenofovir alafenamide hemifumarate

Product Monograph

§ Expressed as the median (range) only.

ψ Expressed as the arithmetic mean (CV%) only.

Study GS-US-311-1473 was a randomized, open-label, single-dose, 2-way crossover study conducted in 116 healthy male and female subjects to compare the bioavailabilities of FTC and TAF from a single dose of DESCOVY (F/TAF) 200/25 mg FDC tablet and a single dose of GENVOYA (E/C/F/TAF) 150/150/200/10 mg FDC tablet under moderate calorie, moderate fat fed conditions. A summary of the data is provided in Table 10.

Table 10. Summary Table of the Comparative Bioavailability Data for Study GS-US-311-1473

Emtricitabine (FTC)
 (1 x 200 mg FTC/25 mg TAF hemifumarate or
 1 x 150 mg EVG/150 mg COBI/200 mg FTC/10 mg TAF hemifumarate)
 From measured data
 Geometric Least Squares Mean
 Arithmetic Mean (CV %)

Parameter	Test*	Reference†	% Ratio of Geometric Means	90% Confidence Interval
AUC _T (ng.h/mL)	9263.96 9423.9 (19.3)	10291.82 10475.3 (19.7)	90.01	88.88 – 91.16
AUC _{Inf} (ng.h/mL)	9490.42 9654.6 (19.3)	10521.69 10706.6 (19.6)	90.20	89.06 – 91.35
C _{max} (ng/mL)	1528.45 1577.4 (26.8)	1571.43 1601.7 (19.6)	97.26	94.57 – 100.03
T _{max} § (h)	2.00 (1.00 - 5.00)	3.00 (1.00 - 5.00)		
T _{1/2} ψ (h)	22.31 (52.0)	21.87 (55.6)		

Tenofovir alafenamide (TAF)
 (1 x 200 mg FTC/25 mg TAF hemifumarate or
 1 x 150 mg EVG/150 mg COBI/200 mg FTC/10 mg TAF hemifumarate)
 From measured data
 Geometric Least Squares Mean
 Arithmetic Mean (CV %)

Parameter	Test*	Reference†	% Ratio of Geometric Means	90% Confidence Interval
AUC _T (ng.h/mL)	344.12 374.0 (43.4)	343.03 369.3 (40.6)	100.32	96.48 - 104.31
AUC _{Inf} (ng.h/mL)	357.37 396.4 (42.6)	362.68 389.5 (39.3)	98.54	94.61 - 102.62
C _{max} (ng/mL)	242.52 280.5 (62.9)	234.03 267.8 (59.8)	103.63	95.46 - 112.49
T _{max} § (h)	1.50 (0.50 - 4.00)	1.50 (0.50 - 3.00)		
T _{1/2} ψ (h)	0.47 (27.1)	0.48 (38.5)		

* DESCOVY (200 mg FTC/25 mg TAF hemifumarate) fixed dose combination tablet administered under moderate fat, moderate calorie fed conditions.
 † GENVOYA (EVG/COBI/FTC/TAF hemifumarate) 150 mg/150 mg/200 mg/10 mg fixed dose combination tablet administered under moderate fat, moderate calorie conditions.
 § Expressed as the median (range) only.
 ψ Expressed as the arithmetic mean (CV%) only.

Treatment-Naïve HIV-1 Infected Patients

In both Studies GS-US-292-0104 (Study 104) and GS-US-292-0111 (Study 111), patients were randomized in a 1:1 ratio to receive either FTC+TAF (N=866) or FTC+TDF (N=867) once daily, both given with EVG+COBI as a FDC tablet (GENVOYA and STRIBILD, respectively).

In Studies 104 and 111, the mean age was 36 years (range 18-76), 85% were male, 57% were White, 25% were Black, and 10% were Asian. Nineteen percent of patients identified as Hispanic/Latino. The mean baseline plasma HIV-1 RNA was 4.5 log₁₀ copies per mL (range 1.3–7.0). The mean baseline CD4+ cell count was 427 cells per mm³ (range 0-1360) and 13% had CD4+ cell counts <200 cells per mm³. Twenty-three percent of patients had baseline viral loads >100,000 copies per mL.

For demographic and baseline characteristics for Studies 104 and 111, see Table 11.

Table 11. Pooled Demographic and Baseline Characteristics of Antiretroviral Treatment-naïve HIV-1 Infected Adult Patients in Studies GS-US-292-0104 and GS-US-292-0111

	FTC+TAF (Administered as GENVOYA) (N=866)	FTC+TDF (Administered as STRIBILD) (N=867)
Demographic characteristics		
Median age, years (range)	33 (18-74)	35 (18-76)
Sex		
Male	733	740
Female	133	127
Race		
American Indian/Alaska Native	5	8
White	485	498
Black	223	213
Native Hawaiian/Pacific Islander	5	4
Asian	91	89
Other	57	55
Baseline disease characteristics		
Median baseline plasma HIV-1 RNA log ₁₀ copies/mL (range)	4.58 (2.57-6.89)	4.58(1.28-6.98)
Percentage of subjects with viral load ≤100,000 copies/mL	77.4	77.5
Percentage of subjects with viral load > 100,000 to ≤400,000 copies/mL	17.0	17.8
Percentage of subjects with viral load >400,000 copies/mL	5.7	4.7
Median baseline CD4+ cell count /μL (range)	404 (0-1311)	406 (1-1360)
Percentage of subjects with CD4+ cell counts <200 cells/mm ³	13.0	13.5
HIV disease status		
Asymptomatic	779	800
Symptomatic HIV infection	53	34
AIDS	31	29
Unknown	3	4
Estimated CrCl by Cockcroft-Gault method (mL/min), median (Q1, Q3)	117.0 (99.6, 135.6)	113.9 (99.0, 133.6)
Proteinuria by urinalysis (dipstick)		
Grade 0	778	780
Grade 1	80	67
Grade 2	8	18
Grade 3	0	1
-Missing-	0	1

FTC=emtricitabine; TAF=tenofovir alafenamide; TDF=tenofovir disoproxil fumarate

14.2 Study Results

Study Results

In both studies, patients were stratified by baseline HIV-1 RNA ($\leq 100,000$ copies per mL, $>100,000$ copies per mL to $\leq 400,000$ copies per mL, or $>400,000$ copies per mL), by CD4 count (<50 cells per μL , 50-199 cells per μL , or ≥ 200 cells per μL), and by region (US or ex-US).

Treatment outcomes of Studies 104 and 111 through Week 48 and Week 144 are presented in Table 12.

Table 12. Pooled Virologic Outcomes of Studies GS-US-292-0104 and GS-US-292-0111 at Week 48^a and Week 144^b

	Week 48		Week 144	
	FTC+TAF (Administered as GENVOYA) (N=866)	FTC+TDF (Administered as STRIBILD) (N=867)	FTC+TAF (Administered as GENVOYA) (N=866)	FTC+TDF (Administered as STRIBILD) (N=867)
Virologic Success HIV-1 RNA < 50 copies/mL	92%	90%	84%	80%
Treatment Difference	2.0% (95% CI: -0.7% to 4.7%)		4.2% (95% CI: 0.6% to 7.8%)	
Virologic Failure HIV-1 RNA ≥ 50 copies/mL^c	4%	4%	5%	4%
No Virologic Data at Week 48 or Week 144 Window	4%	6%	11%	16%
Discontinued Study Drug Due to AE or Death ^d	1%	2%	1%	3%
Discontinued Study Drug Due to Other Reasons and Last Available HIV-1 RNA <50 copies/ mL ^e	2%	4%	9%	11%
Missing Data During Window but on Study Drug	1%	<1%	1%	1%
Proportion (%) of Subjects with HIV-1 RNA <50 copies/mL by Subgroup				
Age				
< 50 years	716/777 (92%)	680/753 (90%)	647/777 (83%)	602/753 (80%)
≥ 50 years	84/89 (94%)	104/114 (91%)	82/89 (92%)	92/114 (81%)
Sex				
Male	674/733 (92%)	673/740 (91%)	616/733 (84%)	603/740 (81%)
Female	126/133 (95%)	111/127 (87%)	113/133 (85%)	91/127 (72%)
Race				
Black	197/223 (88%)	177/213 (83%)	168/223 (75%)	152/213 (71%)
Nonblack	603/643 (94%)	607/654 (93%)	561/643 (87%)	542/654 (83%)
Baseline Viral Load				
≤ 100,000 copies/mL	629/670 (94%)	610/672 (91%)	567/670 (85%)	537/672 (80%)
> 100,000 copies/mL	171/196 (87%)	174/195 (89%)	162/196 (83%)	157/195 (81%)

DESCOVY (emtricitabine/tenofovir alafenamide*) tablets

*as tenofovir alafenamide hemifumarate

Product Monograph

	Week 48		Week 144	
	FTC+TAF (Administered as GENVOYA) (N=866)	FTC+TDF (Administered as STRIBILD) (N=867)	FTC+TAF (Administered as GENVOYA) (N=866)	FTC+TDF (Administered as STRIBILD) (N=867)
Baseline CD4+ cell count				
< 200 cells/mm ³	96/112 (86%)	104/117 (89%)	93/112 (83%)	94/117 (80%)
≥ 200 cells/mm ³	703/753 (93%)	680/750 (91%)	635/753 (84%)	600/750 (80%)

FTC=emtricitabine; TAF=tenofovir alafenamide; TDF=tenofovir disoproxil fumarate

- a Week 48 window was between Day 294 and 377 (inclusive).
- b Week 144 window was between Day 966 and 1049 (inclusive).
- c Included patients who had ≥50 copies/mL in the Week 48 or Week 144 window; patients who discontinued early due to lack or loss of efficacy; patients who discontinued for reasons other than an adverse event (AE), death or lack or loss of efficacy and at the time of discontinuation had a viral value of ≥50 copies/mL.
- d Includes patients who discontinued due to AE or death at any time point from Day 1 through the time window if this resulted in no virologic data on treatment during the specified window.
- e Includes patients who discontinued for reasons other than an AE, death or lack or loss of efficacy; e.g., withdrew consent, loss to follow-up, etc.

In Studies 104 and 111, FTC+TAF met the noninferiority criteria in achieving HIV-1 RNA <50 copies/mL at Week 48 and Week 96, when compared to FTC+TDF, both given with EVG+COBI as a FDC tablet (GENVOYA and STRIBILD, respectively). At Week 144, FTC+TAF (administered as GENVOYA) demonstrated statistical superiority ($p=0.021$) in achieving HIV-1 RNA < 50 copies/mL when compared to FTC+TDF (administered as STRIBILD). In Studies 104 and 111, the 95% CIs for differences in virologic success between treatment groups included zero for most subgroups evaluated suggesting no differences between the treatments.

The mean increase from baseline in CD4+ cell count at Week 48, Week 96, and Week 144 was 230 cells/mm³, 280 cells/mm³, and 326 cells/mm³, respectively, in patients receiving FTC+TAF, and 211 cells/mm³, 266 cells/mm³, and 305 cells/mm³, respectively, in patients receiving FTC+TDF ($p=0.024$, $p=0.14$, and $p=0.06$ at Week 48, Week 96, and Week 144, respectively).

Bone Mineral Density

In the pooled analysis of Studies 104 and 111, the effects of FTC+TAF compared to that of FTC+TDF on bone mineral density (BMD) from baseline to Week 48, Week 96, and Week 144 were assessed by dual-energy X-ray absorptiometry (DXA). As shown in Table 13, in patients who had both baseline and Week 48, 96, and Week 144 measurements (Week 48: N=780 and 784 in patients receiving FTC+TAF and N=767 and 773 in patients receiving FTC+TDF, for hip and spine, respectively; Week 96: N=716 and 722 in patients receiving FTC+TAF and N=711 and 714 in patients receiving FTC+TDF, for hip and spine, respectively; Week 144: N = 690 and 702 in patients receiving FTC+TAF and N = 683 and 686 in patients receiving FTC+TDF, for hip and spine, respectively), there were smaller decreases in BMD in patients receiving FTC+TAF as compared to patients receiving FTC+TDF, both given with EVG+COBI as a FDC tablet (GENVOYA and STRIBILD, respectively).

Table 13. Measures of Bone Mineral Density in Studies GS-US-292-0104 and GS-US-292-0111 (Week 48, Week 96, and Week 144 Analyses)

	Week 48				Week 96				Week 144			
	FTC+TAF (Administered as GENVOYA)	FTC+TDF (Administered as STRIBILD)	Treatment Difference		FTC+TAF (Administered as GENVOYA)	FTC+TDF (Administered as STRIBILD)	Treatment Difference		FTC+TAF (Administered as GENVOYA)	FTC+TDF (Administered as STRIBILD)	Treatment Difference	
Hip DXA Analysis	N=780	N=767	Difference in LSM (95% CI)	P- value	N=716	N=711	Difference in LSM (95% CI)	P- value	N=690	N=683	Difference in LSM (95% CI)	P- value
Mean (SD) Percent Change in BMD	-0.7% (3.3%)	-3.0% (3.4%)	2.3% (2.0 to 2.6)	p < 0.001	-0.7% (3.9%)	-3.3% (4.0%)	2.6% (2.2 to 3.0)	p < 0.001	-0.8% (4.4%)	-3.4% (4.3%)	2.6% (2.2 to 3.1)	p < 0.001
Patients with Categorical Change:												
> 3% Decrease in BMD	17%	50%	--	--	23%	56%	--	--	28%	55%	--	--
> 3% Increase in BMD	7%	3%			12%	6%			13%	6%		
Patients with No Decrease (≥ zero % change) in BMD	35%	14%	--	--	39%	16%	--	--	40%	19%	--	--
Lumbar Spine DXA Analysis	N=784	N=773			N=722	N=714			N=702	N=686		
Mean (SD) Percent Change in BMD	-1.3% (3.1%)	-2.9% (3.2%)	1.6% (1.2 to 1.9)	p < 0.001	-1.0% (3.7%)	-2.8% (3.9%)	1.8% (1.4 to 2.2)	p < 0.001	-0.9% (4.1%)	-3.0% (4.3%)	2.0% (1.6 to 2.5)	p < 0.001

DESCOVY (emtricitabine/tenofovir alafenamide*) tablets
 *as tenofovir alafenamide hemifumarate
 Product Monograph

	Week 48				Week 96				Week 144			
	FTC+TAF (Administered as GENVOYA)	FTC+TDF (Administered as STRIBILD)	Treatment Difference		FTC+TAF (Administered as GENVOYA)	FTC+TDF (Administered as STRIBILD)	Treatment Difference		FTC+TAF (Administered as GENVOYA)	FTC+TDF (Administered as STRIBILD)	Treatment Difference	
Patients with Categorical Change: > 3% Decrease in BMD	27%	46%	--	--	26%	48%	--	--	30%	49%	--	--
	7%	3%			11%	6%			13%	7%		
> 3% Increase in BMD												
Patients with No Decrease (≥ zero % change) in BMD	34%	17%	--	--	37%	21%	--	--	39%	22%	--	--

FTC=emtricitabine; TAF=tenofovir alafenamide; TDF=tenofovir disoproxil fumarate

Changes in Renal Laboratory Tests and Renal Safety

In the pooled analysis of Studies 104 and 111, laboratory tests were performed to compare the effect of TAF to that of TDF on renal laboratory parameters. As shown in Table 14, statistically significant differences were observed between treatment groups that favored TAF for increases in serum creatinine and changes in proteinuria, including urine protein to creatinine ratio (UPCR), urine albumin to creatinine ratio (UACR), urine retinol binding protein (RBP) to creatinine ratio, and urine beta-2-microglobulin to creatinine ratio. There were zero cases of Fanconi syndrome or Proximal Renal Tubulopathy (PRT) in the FTC+TAF group through Week 144.

Table 14. Change from Baseline in Renal Laboratory Tests in Studies GS-US-292-0104 and GS-US-292-0111 (Week 48, Week 96, and Week 144 Analyses)

	Week 48			Week 96			Week 144		
	FTC+TAF (Administered as GENVOYA) (N=866)	FTC+TDF (Administered as STRIBILD) (N=867)	Treatment Difference	FTC+TAF (Administered as GENVOYA) (N=866)	FTC+TDF (Administered as STRIBILD) (N=867)	Treatment Difference	FTC+TAF (Administered as GENVOYA) (N=866)	FTC+TDF (Administered as STRIBILD) (N=867)	Treatment Difference
Serum Creatinine ($\mu\text{mol/L}$) ^a	7.07 \pm 10.96	9.72 \pm 19.18	-3.54 p < 0.001	3.54 \pm 10.08	6.19 \pm 11.23	-2.65 p < 0.001	3.54 \pm 10.61	6.19 \pm 11.23	-3.54 p < 0.001
Proteinuria by Urine Dipstick ^b	31%	37%	p = 0.022	36%	41%	p = 0.034	40%	45%	p = 0.027
Urine Protein to Creatinine Ratio [UPCR] ^c	-3.4%	19.8%	p < 0.001	-9.1%	16.2%	p < 0.001	-10.5%	25.2%	p < 0.001
Urine Albumin to Creatinine Ratio [UACR] ^{c,d}	-4.7%	7.1%	p < 0.001	-5.2%	4.9%	p < 0.001	^d	^d	^d
Urine RBP to Creatinine Ratio ^c	9.2%	51.2%	p < 0.001	13.8%	74.2%	p < 0.001	34.8%	111%	p < 0.001
Urine Beta-2- Microglobulin to Creatinine Ratio ^c	-31.7%	24.1%	p < 0.001	-32.1%	33.5%	p < 0.001	-25.7%	53.8%	p < 0.001

FTC=emtricitabine; TAF=tenofovir alafenamide; TDF=tenofovir disoproxil fumarate

a Mean change \pm SD

b Includes all severity grades (1-3)

c Median percent change

d. UACR was assessed up to Week 96

In addition to the tabulated differences (shown in Table 14) in serum creatinine and proteinuria, there were other differences in tests of proximal renal tubular function that favored TAF. At Weeks 48, 96, and 144, the proportion of patients with any grade hypophosphatemia was 3.6%, 5.6%, and 6.8%, respectively, in patients receiving FTC+TAF, and 4.0%, 5.4%, and 7.6%, respectively, in patients receiving FTC+TDF, both given with EVG+COBI as a FDC tablet (GENVOYA and STRIBILD, respectively). The median (Q1, Q3) change from baseline in FEPO₄ was 2.0% (-1.2%, 5.6%), 2.1% (-1.3%, 5.5%), and 3.0% (-0.7%, 7.2%) at Weeks 48, 96, and 144, respectively, in patients receiving FTC+TAF, and 2.6% (-0.7%, 6.4%), 2.7% (-0.8%, 7.0%), and 4.1% (0.2%, 8.0%) at Weeks 48, 96, and 144, respectively, in patients receiving FTC+TDF (p=0.006, p=0.009, and p=0.001 at Weeks 48, 96, and 144, respectively).

The median (Q1, Q3) change from baseline in the ratio of the renal tubular maximum reabsorption rate of phosphate to the glomerular filtration rate (TmP/GFR) was -0.2 mg/dL (-0.7 mg/dL, 0.2 mg/dL), -0.3 mg/dL (-0.9 mg/dL, 0.2 mg/dL), and -0.4 mg/dL (-1.0 mg/dL, 0.1 mg/dL) at Weeks 48, 96, and 144, respectively, in patients receiving FTC+TAF, and -0.3 mg/dL (-0.7 mg/dL, 0.2 mg/dL), -0.4 mg/dL (-0.8 mg/dL, 0.1 mg/dL), and -0.5 mg/dL (-1.0 mg/dL, 1.0 mg/dL) at Weeks 48, 96, and 144, respectively, in patients receiving FTC+TDF (p=0.21, p=0.35, and p=0.011 at Weeks 48 and, 96, and 144, respectively).

Changes in Lipid Laboratory Tests

Increases from baseline were observed in both treatment groups for the fasting lipid parameters total cholesterol, direct LDL, HDL, and triglycerides at Week 48, 96, and 144. The median increase from baseline for these parameters was greater in patients receiving FTC+TAF compared with patients receiving FTC+TDF, both given with EVG+COBI as a FDC tablet (p<0.001 for the difference between treatment groups for fasting total cholesterol, direct LDL, HDL, and triglycerides). Median (Q1, Q3) change from baseline at Week 48, 96, and 144 in total cholesterol to HDL ratio was 0.1 (-0.3, 0.5), 0.1 (-0.3, 0.7), and 0.2 (-0.3, 0.7), respectively, in patients receiving FTC+TAF and 0.0 (-0.5, 0.4), 0.0 (-0.4, 0.5) and 0.1 (-0.4, 0.6), respectively, in patients receiving FTC+TDF (p<0.001 for the difference between treatment groups at Weeks 48 and 96; p=0.006 at Week 144) (see **ADVERSE REACTIONS**).

Pediatric Patients

In Study 106, the efficacy, safety, and pharmacokinetics of FTC+TAF, given with EVG+COBI as a FDC tablet (administered as GENVOYA), were evaluated in an open-label study in HIV-1-infected treatment-naïve adolescents between the ages of 12 to <18 years (>35 kg) (N=50) through Week 48, and in virologically suppressed pediatric patients between the ages of 6 to <12 years (≥25 kg) (N=23) through Week 24.

Cohort 1: Treatment-Naïve Adolescents (12 to <18 Years of Age and Weighing ≥35 kg)

Patients in Cohort 1 had a mean age of 15 years (range: 12 to 17), 44% were male, 12% were Asian, and 88% were Black. At baseline, mean plasma HIV-1 RNA was 4.6 log₁₀ copies/mL, median CD4+ cell count was 456 cells/mm³ (range: 95 to 1110), and

median CD4+% was 23% (range: 7% to 45%). Twenty-two percent had baseline plasma HIV-1 RNA >100,000 copies/mL as shown in Table 15.

Cohort 2: Virologically Suppressed Children (6 to < 12 Years of Age and Weighing ≥ 25 kg)

Patients in Cohort 2 had a mean age of 10 years (range: 8 to 11), a mean baseline weight of 31.6 kg (range: 26 to 58), 39% were male, 13% were Asian, and 78% were Black. At baseline, median CD4+ cell count was 969 cells/mm³ (range: 603 to 1421), and median CD4+% was 39% (range: 30% to 51%). All 23 patients had baseline plasma HIV-1 RNA < 50 copies/mL as shown in Table 15.

Table 15. Demographic and Baseline Characteristics of Treatment-Naïve HIV-1 Infected Adolescents (Cohort 1) and Virologically Suppressed Children (Cohort 2) in Study GS-US-292-0106

	Cohort 1	Cohort 2
	FTC+TAF (Administered as GENVOYA) (N=50)	FTC+TAF (Administered as GENVOYA) (N=23)
Demographic characteristics		
Median age, years (range)	15 (12-17)	10 (8-11)
Sex		
Male	22	9
Female	28	14
Race		
Asian	6	3
Black	44	18
White	0	2
BMI (kg/m ²), median (Q1, Q3)	20.0 (18.1, 23.1)	15.9 (15.2, 18.1)
Baseline disease characteristics		
HIV-1 RNA (log ₁₀ copies/mL), median (Q1, Q3)	4.65 (4.25, 4.94)	N/A
HIV-1 RNA >100,000 copies/mL	11	0
HIV-1 RNA < 50 copies/mL	0	23
CD4+ cell count (cells/μL), median (Q1, Q3)	456 (332, 574)	969 (843, 1087)
Mode of infection (HIV risk factors)		
Heterosexual sex	12	0
Homosexual sex	8	0
IV drug use	1	0
Vertical transmission	32	23
HIV disease status		
Asymptomatic	42	23
Symptomatic HIV infection	8	0
Estimated CrCl by Schwartz formula (mL/min/1.73 m ²), median (Q1, Q3)	156 (129.0, 185.0)	150.0 (134.7, 165.6)
Proteinuria by urinalysis (dipstick)		
Grade 0	48	22
Grade 1	1	1

DESCOVY (emtricitabine/tenofovir alafenamide*) tablets

*as tenofovir alafenamide hemifumarate

Product Monograph

Grade 2	1	0
Grade 3	0	0

FTC=emtricitabine; TAF=tenofovir alafenamide

Study results

Cohort 1: Treatment-naïve Adolescents (≥12 to <18 Years of Age and Weighing ≥35 kg)

At Week 24, out of 23 patients assessed for efficacy, 91% achieved HIV-1 RNA <50 copies/mL, and at Week 48, 92% (46/50) achieved HIV-1 RNA <50 copies/mL, similar to response rates in trials of treatment-naïve HIV-1 infected adults. The mean increase from baseline in CD4+ cell count at Week 24 and Week 48 was 212 and 224 cells/mm³, respectively. Two patients had virologic failure by snapshot at Week 24 and three of the 50 patients had virologic failure by snapshot at Week 48; no emergent resistance to FTC and TAF was detected through Week 24 and Week 48.

Fifty patients in Cohort 1 were assessed for safety at Week 24 and Week 48 (these patients received FTC+TAF (10 mg) given with EVG+COBI as a FDC tablet (GENVOYA) for 24 and 48 weeks). BMD by DXA was assessed in 47 patients for spine at both Week 24 and Week 48. BMD by DXA was assessed in 45 and 44 patients for total body less head (TBLH) at Week 24 and Week 48, respectively. Mean (SD) BMD increased from baseline to Week 24, +1.6% (3.9%) at the lumbar spine and +0.6% (2.5%) for TBLH. Mean (SD) BMD increased from baseline to Week 48, +4.2% (5.0%) at the lumbar spine and +1.3% (2.7%) for TBLH.

Cohort 2: Virologically Suppressed Children (6 to <12 Years of Age and Weighing ≥25 kg)

At Week 24, 100% (23/23) of patients in Cohort 2 remained suppressed (HIV-1 RNA < 50 copies/mL) after switching to FTC+TAF (10 mg) given with EVG+COBI as a FDC tablet (GENVOYA). The mean change from baseline in CD4+ cell count at Week 24 was -150 cells/mm³. No emergent resistance was detected through Week 24.

Among the patients in Cohort 2 who had both baseline and Week 24 measurements, BMD by DXA was assessed in 21 patients for spine and 23 patients for TBLH. Mean (SD) BMD increased from baseline to Week 24, +2.9% (4.9%) at the lumbar spine and +1.7% (2.5%) for TBLH.

15 MICROBIOLOGY

Antiviral Activity

Emtricitabine: The antiviral activity of FTC against laboratory and clinical isolates of HIV-1 was assessed in lymphoblastoid cell lines, the MAGI-CCR5 cell line, and primary peripheral blood mononuclear cells. The 50% effective concentration (EC₅₀) values for FTC were in the range of 0.0013 to 0.64 µM. Emtricitabine displayed antiviral activity in

cell culture against HIV-1 clades A, B, C, D, E, F, and G (EC₅₀ values ranged from 0.007 to 0.075 µM) and showed strain specific activity against HIV-2 (EC₅₀ values ranged from 0.007 to 1.5 µM).

In two-drug combination studies of FTC with NRTIs (abacavir, didanosine, lamivudine, stavudine, tenofovir, and zidovudine), non-nucleoside reverse transcriptase inhibitors (NNRTIs) (delavirdine, efavirenz, nevirapine, and rilpivirine), protease inhibitors (PIs) (amprenavir, nelfinavir, ritonavir, and saquinavir), and the integrase strand transfer inhibitor EVG, additive to synergistic effects were observed. No antagonism was observed for these combinations.

Tenofovir Alafenamide: The antiviral activity of TAF against laboratory and clinical isolates of HIV-1 subtype B was assessed in lymphoblastoid cell lines, PBMCs, primary monocyte/macrophage cells and CD4-T lymphocytes. The EC₅₀ values for TAF were in the range of 2.0 to 14.7 nM. Tenofovir alafenamide displayed antiviral activity in cell culture against all HIV-1 groups (M, N, O), including sub-types A, B, C, D, E, F, and G (EC₅₀ values ranged from 0.10 to 12.0 nM) and strain specific activity against HIV-2 (EC₅₀ values ranged from 0.91 to 2.63 nM). Overall, TAF showed potent antiviral activity against the HIV-1 groups/subtypes evaluated.

In a study of TAF with a broad panel of representatives from the major classes of approved anti-HIV agents (NRTIs, NNRTIs, integrase strand transfer inhibitors (INSTIs), and PIs), additive to synergistic effects were observed. No antagonism was observed for these combinations.

Resistance

In Cell Culture

Emtricitabine: HIV-1 isolates with reduced susceptibility to FTC have been selected in cell culture. Reduced susceptibility to FTC was associated with M184V/I substitutions in HIV-1 RT.

Tenofovir Alafenamide: HIV-1 isolates with reduced susceptibility to TAF have been selected in cell culture. HIV-1 isolates selected by TAF expressed a K65R mutation in HIV-1 RT; in addition, a K70E mutation in HIV-1 RT has been transiently observed. HIV-1 isolates with the K65R substitution have low-level reduced susceptibility to abacavir, FTC, TAF, tenofovir, and lamivudine. *In vitro* drug resistance selection studies with TAF have shown no development of resistance increases above 2.5-fold after 6 months in culture.

In Clinical Trials

In Treatment-Naïve Patients: In a pooled analysis of antiretroviral-naïve patients receiving FTC+TAF given with EVG+COBI as a FDC tablet in Phase 3 Studies, 104 and 111, genotyping was performed on plasma HIV-1 isolates from all patients with HIV-1 RNA ≥400 copies/mL at confirmed virologic failure, at Week 144, or at time of early

study drug discontinuation. As of Week 144, the development of one or more primary EVG, FTC, or TAF resistance-associated with resistance was observed in 12 of 22 patients with evaluable genotypic data from paired baseline and FTC+TAF given with EVG+COBI as a FDC tablet treatment-failure isolates (12 of 866 patients [1.4%]) compared with 12 of 20 treatment-failure isolates from patients with evaluable genotypic data in the FTC+TDF given with EVG+COBI as a FDC tablet group (12 of 867 patients [1.4%]). Of the 12 patients with resistance development in the FTC+TAF given with EVG+COBI as a FDC tablet group, the mutations that emerged against FTC and/or TAF were M184V/I (N=11) and K65R/N (N=2) in reverse transcriptase and T66T/A/I/V (N=2), E92Q (N=4), Q148Q/R (N=1), and N155H (N=2) in integrase. Of the 12 patients with resistance development in the FTC+TDF given with EVG+COBI as a FDC tablet group, the mutations that emerged against FTC and/or TDF were M184V/I (N=9) and K65R/N (N=4), and L210W (N=1) in reverse transcriptase and E92Q/V (N=4), Q148R (N=2), and N155H/S (N=3) in integrase.

In phenotypic analyses of patients in the final resistance analysis population, 8 of 22 patients (36%) receiving FTC+TAF given with EVG+COBI as a FDC tablet had HIV-1 isolates with reduced susceptibility to FTC compared with 7 of 20 patients with data (35%) receiving FTC+TDF given with EVG+COBI as a FDC tablet. One patient receiving FTC+TAF given with EVG+COBI as a FDC tablet (1 of 22 [4.5%]) and 2 patients receiving FTC+TDF given with EVG+COBI as a FDC tablet (2 of 20 with data, [10%]) had reduced susceptibility to tenofovir. Finally, 7 of 22 patients (32%) had reduced susceptibility to EVG in the FTC+TAF given with EVG+COBI as a FDC tablet group compared with 7 of 20 patients (35%) in the FTC+TDF given with EVG+COBI as a FDC tablet group.

In Virologically Suppressed Patients: In a Week 96 analysis of virologically suppressed patients who changed their background regimen from FTC+TDF to DESCOVY while maintaining their third antiretroviral agent (GS-US-311-1089), 1 of 4 patients analyzed in the DESCOVY+third agent group (1 of 333 [0.3%]) developed M184V in reverse transcriptase in the first 48 weeks with reduced susceptibility to FTC. In the FTC/TDF+third agent group, 0 of 3 patients analyzed (0 of 333 [0%]) developed resistance to any components of their regimen.

Cross Resistance

No cross-resistance has been demonstrated for elvitegravir-resistant HIV-1 isolates and FTC or tenofovir, or for FTC- or tenofovir-resistant isolates and EVG.

Emtricitabine: Cross-resistance has been observed among NRTIs. Emtricitabine-resistant isolates harboring an M184V/I substitution in HIV-1 RT were cross-resistant to lamivudine. HIV-1 isolates containing the K65R RT substitution, selected *in vivo* by abacavir, didanosine, and tenofovir, demonstrated reduced susceptibility to inhibition by FTC.

Tenofovir Alafenamide: The K65R and K70E mutations result in reduced susceptibility to abacavir, didanosine, lamivudine, FTC, and tenofovir, but retain sensitivity to zidovudine. Multinucleoside resistant HIV-1 with a T69S double insertion mutation or with a Q151M mutation complex including K65R showed reduced susceptibility to TAF.

HIV-1 containing the K103N or Y181C mutations associated with resistance to NNRTIs were susceptible to TAF. HIV-1 containing mutations associated with resistance to PIs, such as M46I, I54V, V82F/T, and L90M were susceptible to TAF.

16 NON-CLINICAL TOXICOLOGY

General

No toxicology studies have been conducted with DESCOVY tablets. The toxicology information is based on studies conducted with FTC or TAF as individual agents.

Tenofovir Alafenamide

The general toxicology profile of TAF has been studied in mice, rats and dogs.

The target organs were the kidney and bone. The effects on the kidneys included cortical tubular basophilia and tubular karyomegaly in both rats and dogs and additionally cortical tubular degeneration/regeneration in dogs. These effects did not appear to meaningfully affect renal function except for possibly related reduction in serum calcitriol (1,25-dihydroxyvitamin D3) that may be implicated in the bone effects (see below). The TAF-related effects on the bone included decreases in bone mineral density and mineral content observed in both rats and dogs. In the 9-month dog study, animals dosed at 18/12 mg/kg/day (approximately 47 times the clinical exposure based on AUC) failed to mature skeletally. The NOAEL in the rat and dog was 25 mg/kg/day (approximately 13 times clinical tenofovir exposure based on AUC) and 2 mg/kg/day (approximately 4 times the clinical tenofovir exposure based on AUC), respectively. These effects were partially reversible upon treatment discontinuation. Electrocardiographic effects occurred in the 9-month dog study and included prolongation of PR intervals at ≥ 6 mg/kg (approximately 15 times the clinical exposure based on AUC) and reduction in heart rate with an associated QT prolongation at 18/12

mg/kg (approximately 47 times the clinical exposure based on AUC); the heart rate changes were reversible following a three-month recovery period. The NOAEL was 2 mg/kg (approximately 4 times the clinical tenofovir exposure based on AUC). These effects might have been due to a reduction in triiodothyronine (T3) levels.

Carcinogenesis

Emtricitabine: In long-term carcinogenicity studies of FTC, no drug-related increases in tumor incidence were found in mice at doses up to 750 mg/kg/day (23 times the human systemic exposure at the therapeutic dose of 200 mg/day) or in rats at doses up to 600 mg/kg/day (28 times the human systemic exposure at the therapeutic dose).

Tenofovir Alafenamide: Because there is a lower tenofovir exposure in rats and mice after TAF administration compared to TDF, carcinogenicity studies were conducted only with TDF. Long-term oral carcinogenicity studies of TDF in mice and rats were carried out at exposures up to approximately 10 times (mice) and 4 times (rats) those observed in humans at the 300 mg therapeutic dose of TDF for HIV-1 infection. At the high dose in female mice, liver adenomas were increased at exposures 10 times that in humans. In rats, the study was negative for carcinogenic findings at exposures up to 4 times that observed in humans at the therapeutic dose.

Mutagenesis

Emtricitabine: Emtricitabine was not genotoxic in the reverse mutation bacterial test (Ames test), mouse lymphoma or mouse micronucleus assays.

Tenofovir Alafenamide: Tenofovir alafenamide was not genotoxic in the reverse mutation bacterial test (Ames test), mouse lymphoma or rat micronucleus assays.

Reproductive Toxicology

Emtricitabine: The incidence of fetal variations and malformations was not increased in embryo-fetal toxicity studies performed with FTC in mice at exposures (AUC) approximately 60 times higher and in rabbits at approximately 120 times higher than human exposures at the recommended daily dose.

Emtricitabine did not affect fertility in male rats at approximately 140-fold or in male and female mice at approximately 60 fold higher exposures (AUC) than in humans given the recommended 200 mg daily dose. Fertility was normal in the offspring of mice exposed daily from before birth (in utero) through sexual maturity at daily exposures (AUC) of approximately 60-fold higher than human exposures at the recommended 200 mg daily dose.

Tenofovir Alafenamide: There were no effects on fertility, mating performance or early embryonic development when TAF was administered to male rats at a dose equivalent to 155 times the human dose based on body surface area comparisons for 28 days

prior to mating and to female rats for 14 days prior to mating through day seven of gestation.

READ THIS FOR SAFE AND EFFECTIVE USE OF YOUR MEDICINE
PATIENT MEDICATION INFORMATION

Pr**DESCOVY**[®]

(emtricitabine/tenofovir alafenamide*) tablets
* as tenofovir alafenamide hemifumarate

Read this carefully before you start taking **Descovy** and each time you get a refill. This leaflet is a summary and will not tell you everything about this drug. Talk to your healthcare professional about your medical condition and treatment and ask if there is any new information about **Descovy**.

Serious Warnings and Precautions

- **“Flare-ups” of Hepatitis B Virus infection, in which the disease suddenly returns in a worse way than before, can occur if you also have hepatitis B and stop taking Descovy. Do not stop taking Descovy without your doctor’s advice. If you stop taking Descovy, tell your doctor immediately about any new, unusual or worsening symptoms that you notice after stopping treatment. After you stop taking Descovy, your doctor will still need to check your health and take blood tests to check your liver. Descovy is not approved for the treatment of hepatitis B virus infection.**

What is Descovy used for?

Descovy is used to treat people with HIV infection. **Descovy** is for adults and children who weigh at least 25 kg (55 lbs).

Descovy is for people who do not have an HIV virus that is resistant to **Descovy**. **Descovy** has not been studied in children weighing less than 25 kg (55 lbs).

How does Descovy work?

Descovy lowers the amount of HIV in the blood (viral load).

HIV infection destroys CD4+ (T) cells. These cells are important to help the immune system fight infections. After a large number of T cells are destroyed, acquired immune deficiency syndrome (AIDS) develops.

Descovy may help increase the count of CD4+ (T) cells. Lowering the amount of HIV in the blood and increasing the CD4+ (T) cells lower the chance of getting infections that happen when your immune system is weak.

Descovy does not cure HIV infection or AIDS. The long-term effects of **Descovy** are not known. People taking **Descovy** may still get infections or other conditions that happen with HIV infection. Some of these conditions are pneumonia and

Mycobacterium avium complex (MAC) infections. **It is very important that you see your doctor on a regular basis while taking Descovy.**

Descovy has not been shown to reduce the risk of passing HIV to others through sexual contact or blood. Continue to practice safe sex. Use condoms to lower the chance of sexual contact with body fluids such as semen, vaginal secretions, or blood. Do not re-use or share needles.

What are the ingredients in Descovy?

Medicinal ingredients: emtricitabine and tenofovir alafenamide*

(* as tenofovir alafenamide hemifumarate)

The tablets include the following inactive ingredients: microcrystalline cellulose, croscarmellose sodium, and magnesium stearate. The grey tablets are film-coated with a coating material containing polyvinyl alcohol, titanium dioxide, polyethylene glycol, talc, and iron oxide black. The blue tablets are film-coated with a coating material containing polyvinyl alcohol, titanium dioxide, polyethylene glycol, talc, and indigo carmine aluminum lake.

Descovy comes in the following dosage forms:

Descovy is available as tablets.

Descovy is available as rectangular-shaped, film-coated tablets containing 200 mg of emtricitabine and either 10 mg or 25 mg of tenofovir alafenamide (grey tablets and blue tablets, respectively). Each tablet is debossed with “GSI” on one side and either “210” (200/10 mg strength) or “225” (200/25 mg strength) on the other side. Each bottle contains 30 tablets and a silica gel desiccant and is closed with a child-resistant closure.

Do not use Descovy if:

- you are taking any medication that is listed in this pamphlet under “**Drugs that should not be taken with Descovy**”
- you are allergic to **Descovy** or any of its ingredients (see: **What are the ingredients in Descovy?**).

To help avoid side effects and ensure proper use, talk to your doctor before you take Descovy. Talk about any health conditions or problems you may have, including if you:

- Also have hepatitis B virus (HBV) infection at the same time and take **Descovy**. Your HBV infection may get worse (flare-up) and symptoms worsen if you stop taking **Descovy** (see **Serious Warnings and Precautions** box and **Serious Side Effects** table).

- Have a history of pancreatitis (swelling of the pancreas). If you develop symptoms of pancreatitis, such as nausea, vomiting and severe pain in the abdomen and/or back, contact your doctor.
- Have kidney problems. Kidney problems, including kidney failure, have occurred in patients taking tenofovir. If you have kidney problems and are taking Descovy along with certain medicines such as non-steroidal anti inflammatory drugs, your kidney problems could get worse.
- Have a history of bone fracture, bone loss or osteoporosis. Bone loss has happened in some people who took **Descovy**.
- Have lactic acidosis (high levels of acid in the blood). See the Serious Side Effects table for symptoms and contact your doctor right away if you get these symptoms.
- Have severe liver problems including enlarged or fatty liver. See the **Serious Side Effects** table for symptoms and contact your doctor right away if you get these symptoms.

Do not run out of **Descovy**. Refill your prescription or talk to your doctor before your **Descovy** is all gone.

Do not stop taking **Descovy** without first talking to your doctor.

If you stop taking **Descovy**, your doctor will need to check your health often and do blood tests regularly for several months to check your HBV infection. Tell your doctor about any new or unusual symptoms you may have after you stop taking **Descovy**.

Other warnings you should know about:

If you are pregnant or plan to become pregnant:

It is not known if **Descovy** can harm your unborn child. Your doctor will decide if you should take **Descovy**.

Pregnancy Registry: There is a pregnancy registry for women who take antiviral medicines during pregnancy. This registry collects information about your health and your baby's health. If you become pregnant while taking **Descovy**, talk with your doctor about taking part in this registry.

If you are breast-feeding or plan to breast-feed:

Do not breast-feed if you have HIV because of the chance of passing the HIV virus to your baby. One of the ingredients of **Descovy**, emtricitabine, can be passed to your baby in your breast milk and may cause harm to your baby. It is not known if the other components can be passed to your baby in breast milk. If you are a woman who has or will have a baby, talk with your doctor about the best way to feed your baby.

Blood Sugar and Fat Levels

Your blood sugar levels (glucose) or level of fats (lipids) in your blood may increase with HIV treatment. Your doctor may order blood tests for you.

Tell your healthcare professional about all the medicines you take, including any drugs, vitamins, minerals, natural supplements or alternative medicines.

Tell your healthcare professional about all the medicines you take, including any drugs, vitamins, minerals, natural supplements or alternative medicines.

Drugs that should not be taken with Descovy:

- Any other medicines that contain tenofovir alafenamide (BIKTARVY[®], GENVOYA[®], ODEFSEY[®], Symtuza[™], VEMLIDY[™]).
- Any other medicines that contain tenofovir disoproxil fumarate (ATRIPLA[®], COMPLERA[®], STRIBILD[®], TRUVADA[®], VIREAD[®]).
- Any other medicines that contain emtricitabine or lamivudine (ATRIPLA, BIKTARVY, COMPLERA, EMTRIVA[®], GENVOYA, ODEFSEY, STRIBILD, Symtuza, TRUVADA; 3TC, Combivir[®], Heptovir[®], Kivexa[®], Triumeq[®], Trizivir[®]).
- adefovir (HEPSERA[®]).

Drugs that interact with Descovy and when the dose of Descovy or the dose of the other drug should be changed or further instruction from your doctor are needed:

Drug Class	Medicinal Ingredient (Brand Name)
Anticonvulsants	carbamazepine (Carbatrol [®] , Epitol [®] , Tegretol [®]), oxcarbazepine (Trileptal [®]), phenobarbital and phenytoin (Dilantin [®])
Antifungals	ketoconazole (Nizoral [®]), itraconazole (Sporanox [®])
Antimycobacterials	rifampin (Rifater [®] , Rifamate [®] , Rofact [®] , Rifadin [®]), rifapentine* (Priftin [®])
Antiretrovirals	tipranavir (Aptivus [®])
Herbal products	<i>Hypericum perforatum</i> (St. John's wort)

These are not all the medicines that may cause problems if you take Descovy. Be sure to tell your doctor about all the medicines you take.

Keep a complete list of all the prescription, nonprescription and herbal medicines that you are taking, how much you take and how often you take them. Make a new list when medicines or herbal medicines are added or stopped, or if the dose changes. Give copies of this list to all your doctors and pharmacists **every** time you visit them or fill a prescription. This will give your doctor a complete picture of the medicines you use. Then he or she can decide the best approach for the situation.

How to take Descovy:

Stay under a doctor's care when taking **Descovy**. Do not change your treatment or stop treatment without first talking with your doctor.

When your **Descovy** supply starts to run low, get more from your doctor or pharmacy. This is very important because the amount of virus in your blood may increase if the medicine is stopped for even a short time. If **Descovy** is not taken on a regular basis, as prescribed, HIV may become harder to treat.

Only take medicine that has been prescribed specifically for you.

Do not give **Descovy** to others or take medicine prescribed for someone else.

Do not use if seal over bottle opening is broken or missing.

Usual dose:

Adults and children weighing 25 kg or more:

- The usual dose of **Descovy** is one tablet orally (by mouth) once a day.
- Try to take the tablet at the same time each day. Swallow with plenty of water.
- Take **Descovy** with or without food.

Overdose:

If you think you have taken too much Descovy, contact your healthcare professional, hospital emergency department or regional Poison Control Centre immediately, even if there are no symptoms.

Missed Dose:

It is important that you do not miss any doses. If you miss a dose of **Descovy** and it is less than 18 hours from the time you usually take **Descovy**, then take the dose. If more than 18 hours has passed from the time you usually take **Descovy**, then wait until the next scheduled daily dose. **Do not** take more than 1 dose of **Descovy** in a day. **Do not** take 2 doses at the same time. Call your doctor or pharmacist if you are not sure what to do.

What are possible side effects from using Descovy?

These are not all the possible side effects you may feel when taking **Descovy**. If you get any side effects not listed here, contact your doctor. Please also see **Serious Warnings and Precautions** box.

The most common side effects of **Descovy** are:

- Nausea.
- Diarrhea.

- Headache.
- Fatigue.

Additional side effects may include:

- Gas.
- Swelling in the face, lips, tongue or throat (angioedema).
- Hives (urticaria).

Changes in your immune system (Immune Reconstitution Inflammatory Syndrome) can happen when you start taking HIV-1 medicines. Your immune system may get stronger and begin to fight infections that have been hidden in your body for a long time.

Autoimmune disorders (when the immune system attacks healthy body tissue), may also occur after you start taking medicines for HIV infection. Examples of this include: Grave's disease (which affects the thyroid gland), Guillain-Barré syndrome (which affects the nervous system), polymyositis (which affects the muscles), or autoimmune hepatitis (which affects the liver). Autoimmune disorders may occur many months after the start of treatment. Look for any other symptoms such as:

- high temperature (fever), redness, rash or swelling
- joint or muscle pain
- numbness or weakness beginning in the hands and feet and moving up towards the trunk of the body
- palpitations (chest pain) or rapid heart rate

If you notice these or any symptoms of inflammation or infection, tell your doctor immediately.

Bone problems can happen in some people who take **Descovy**. Bone problems may include bone pain, softening or thinning (which may lead to fractures). Your doctor may need to do tests to check your bones.

Serious side effects and what to do about them			
Symptom / effect	Talk to your healthcare professional		Stop taking drug and get immediate medical help
	Only if severe	In all cases	
<u>RARE</u> Effect: Lactic acidosis Symptoms:			

<ul style="list-style-type: none"> • Feeling very weak or tired • Unusual muscle pain • Stomach pain with nausea and vomiting • Feeling unusually cold, especially in arms and legs • Feeling dizzy or lightheaded • Fast or irregular heartbeat • Fast and deep breathing 		<ul style="list-style-type: none"> ✓ ✓ ✓ ✓ ✓ ✓ ✓ 	
<p><u>VERY RARE</u> Effect: Flare-ups of hepatitis B virus infection following drug discontinuation Symptoms:</p> <ul style="list-style-type: none"> • Jaundice (skin or the white part of eyes turns yellow) • Urine turns dark • Bowel movements (stools) turn light in color • Loss of appetite for several days or longer • Feeling sick to your stomach (nausea) • Lower stomach pain 		<ul style="list-style-type: none"> ✓ ✓ ✓ ✓ ✓ ✓ 	
<p><u>VERY RARE</u> Effect: Hepatotoxicity (severe liver problems) with hepatomegaly (liver enlargement) and steatosis (fat in the liver) Symptoms:</p>			

• Jaundice (skin or the white part of eyes turns yellow)		✓	
• Urine turns dark		✓	
• Bowel movements (stools) turn light in color		✓	
• Loss of appetite for several days or longer		✓	
• Feeling sick to your stomach (nausea)		✓	
• Lower stomach pain		✓	

If you have a troublesome symptom or side effect that is not listed here or becomes bad enough to interfere with your daily activities, talk to your healthcare professional.

Reporting Side Effects

You can help improve the safe use of health products for Canadians by reporting serious and unexpected side effects to Health Canada. Your report may help to identify new side effects and change the product safety information.

3 ways to report:

- Online at MedEffect: www.canada.ca/en/health-canada/services/drugs-health-products/medeffect-canada;
- By calling 1-866-234-2345 (toll-free);
- By completing a Consumer Side Effect Reporting Form and sending it by:

— Fax to 1-866-678-6789 (toll-free), or

— Mail to: Canada Vigilance Program
Health Canada, Postal Locator 1908C
Ottawa, ON
K1A 0K9

Postage paid labels and the Consumer Side Effect Reporting Form are available at MedEffect at www.canada.ca/en/health-canada/services/drugs-health-products/medeffect-canada.

NOTE: Contact your healthcare professional if you need information about how to manage your side effects. The Canada Vigilance Program does not provide medical advice.

Storage:

- **Descovy** should be stored below 30°C (86°F). It should remain stable until the expiration date printed on the label.
- Keep **Descovy** in its original container and keep the container tightly closed.

- Keep out of reach and sight of children.

If you want more information about Descovy:

- Talk to your healthcare professional.
- Find the full product monograph that is prepared for healthcare professionals and includes this Patient Medication Information by visiting the Health Canada website (<https://www.canada.ca/en/health-canada/services/drugs-health-products/drug-products/drug-product-database.html>); the manufacturer's website (www.gilead.ca); or by calling 1-866-207-4267.

This leaflet was prepared by Gilead Sciences Canada, Inc.

Last Revised: September 23, 2019

Gilead Sciences, Inc.

Foster City, CA 94404
USA

Gilead Sciences Canada, Inc.

Mississauga, ON L5N 2W3

ATRIPLA[®], BIKTARVY[®], COMPLERA[®], DESCOVY[®], EMTRIVA[®], GENVOYA[®], HEPSERA[®], ODEFSEY[®], STRIBILD[®], TRUVADA[®], VEMLIDY[™], and VIREAD[®] are trademarks of Gilead Sciences, Inc. or its related companies.

All other marks referenced herein are the property of their respective owners.

© 2019 Gilead Sciences, Inc.

e177688-GS-005

HIGHLIGHTS OF PRESCRIBING INFORMATION

These highlights do not include all the information needed to use DESCOVY safely and effectively. See full prescribing information for DESCOVY.

DESCOVY® (emtricitabine and tenofovir alafenamide) tablets, for oral use
Initial U.S. Approval: 2015

WARNING: POST-TREATMENT ACUTE EXACERBATION OF HEPATITIS B and RISK OF DRUG RESISTANCE WITH USE OF DESCOVY FOR HIV-1 PRE-EXPOSURE PROPHYLAXIS (PrEP) IN UNDIAGNOSED EARLY HIV-1 INFECTION

See full prescribing information for complete boxed warning.

Severe acute exacerbations of hepatitis B (HBV) have been reported in HBV-infected individuals who have discontinued products containing emtricitabine (FTC) and/or tenofovir disoproxil fumarate (TDF), and may occur with discontinuation of DESCOVY. Hepatic function should be monitored closely in these individuals. If appropriate, anti-hepatitis B therapy may be warranted. (5.1)

DESCOVY used for HIV-1 PrEP must only be prescribed to individuals confirmed to be HIV-negative immediately prior to initiating and at least every 3 months during use. Drug-resistant HIV-1 variants have been identified with use of FTC/TDF for HIV-1 PrEP following undetected acute HIV-1 infection. Do not initiate DESCOVY for HIV-1 PrEP if signs or symptoms of acute HIV-1 infection are present unless negative infection status is confirmed. (5.2)

RECENT MAJOR CHANGES

Boxed Warning	10/2019
Indications and Usage (1.2)	10/2019
Dosage and Administration (2.1, 2.2)	10/2019
Dosage and Administration (2.3, 2.4, 2.5)	12/2019
Contraindications (4)	10/2019
Warnings and Precautions (5.2)	10/2019
Warnings and Precautions (5.4)	12/2019

INDICATIONS AND USAGE

HIV-1 Treatment (1.1):

DESCOVY is a two-drug combination of emtricitabine (FTC) and tenofovir alafenamide (TAF), both HIV nucleoside analog reverse transcriptase inhibitors (NRTIs), and is indicated:

- in combination with other antiretroviral agents for the treatment of HIV-1 infection in adults and pediatric patients weighing at least 35 kg.
- in combination with other antiretroviral agents other than protease inhibitors that require a CYP3A inhibitor for the treatment of HIV-1 infection in pediatric patients weighing at least 25 kg and less than 35 kg.

HIV-1 PrEP (1.2):

DESCOVY is indicated in at-risk adults and adolescents weighing at least 35 kg for pre-exposure prophylaxis (PrEP) to reduce the risk of HIV-1 infection from sexual acquisition, excluding individuals at risk from receptive vaginal sex. Individuals must have a negative HIV-1 test immediately prior to initiating DESCOVY for HIV-1 PrEP.

Limitations of Use (1.2):

The indication does not include use of DESCOVY in individuals at risk of HIV-1 from receptive vaginal sex because effectiveness in this population has not been evaluated.

DOSAGE AND ADMINISTRATION

- Testing: Prior to or when initiating DESCOVY, test for hepatitis B virus infection. Prior to or when initiating DESCOVY, and during use on a clinically appropriate schedule, assess serum creatinine, estimated creatinine clearance, urine glucose, and urine protein in all individuals. In individuals with chronic kidney disease, also assess serum phosphorus. (2.1)

- HIV-1 Screening: Screen all individuals for HIV-1 infection immediately prior to initiating DESCOVY for HIV-1 PrEP and at least once every 3 months while taking DESCOVY, and upon diagnosis of any other sexually transmitted infections (STIs). (2.2)
- Recommended dosage:
 - Treatment of HIV-1 Infection: One tablet taken once daily with or without food in patients with body weight at least 25 kg. (2.3)
 - HIV-1 PrEP: One tablet taken once daily with or without food in individuals with body weight at least 35 kg. (2.4)
- Renal impairment: DESCOVY is not recommended in individuals with estimated creatinine clearance of 15 to below 30 mL per minute, or below 15 mL per minute who are not receiving chronic hemodialysis. (2.5)

DOSAGE FORMS AND STRENGTHS

Tablets: 200 mg of FTC and 25 mg of TAF (3)

CONTRAINDICATIONS

DESCOVY for HIV-1 PrEP is contraindicated in individuals with unknown or positive HIV-1 status. (4)

WARNINGS AND PRECAUTIONS

- Comprehensive management to reduce the risk of sexually transmitted infections (STIs), including HIV-1, when DESCOVY is used for HIV-1 PrEP: Counsel on adherence to daily dosing and safer sex practices, including condoms, to reduce the risk of STIs. (5.2)
- Management to reduce the risk of acquiring HIV-1 drug resistance when DESCOVY is used for HIV-1 PrEP: refer to full prescribing information for additional detail. (5.2)
- Immune reconstitution syndrome during treatment of HIV-1 infection: May necessitate further evaluation and treatment. (5.3)
- New onset or worsening renal impairment: Assess serum creatinine, estimated creatinine clearance, urine glucose, and urine protein when initiating DESCOVY and during use on a clinically appropriate schedule in all individuals. Also assess serum phosphorus in individuals with chronic kidney disease. (5.4)
- Lactic acidosis/severe hepatomegaly with steatosis: Discontinue DESCOVY in individuals who develop symptoms or laboratory findings suggestive of lactic acidosis or pronounced hepatotoxicity. (5.5)

ADVERSE REACTIONS

- In HIV-1 infected patients, the most common adverse reaction (incidence greater than or equal to 10%, all grades) was nausea. (6.1)
- In HIV-1 uninfected adults in a PrEP trial, the most common adverse reaction (incidence greater than or equal to 5%, all grades) was diarrhea. (6.1)

To report SUSPECTED ADVERSE REACTIONS, contact Gilead Sciences, Inc. at 1-800-GILEAD-5 or FDA at 1-800-FDA-1088 or www.fda.gov/medwatch.

DRUG INTERACTIONS

Consult the Full Prescribing Information prior to and during use for potential drug interactions. (7, 12.3)

USE IN SPECIFIC POPULATIONS

- Lactation: Mothers infected with HIV-1 should be instructed not to breastfeed, due to the potential for HIV transmission. (8.2)
- Pediatrics:
 - Treatment of HIV-1 Infection: Not recommended for patients weighing less than 25 kg. (8.4)
 - HIV-1 PrEP: Not recommended for individuals weighing less than 35 kg. (8.4)

See 17 for PATIENT COUNSELING INFORMATION and Medication Guide.

Revised: 12/2019

FULL PRESCRIBING INFORMATION: CONTENTS***WARNING: POST-TREATMENT ACUTE EXACERBATION OF HEPATITIS B AND RISK OF DRUG RESISTANCE WITH USE OF DESCOVY FOR HIV-1 PRE-EXPOSURE PROPHYLAXIS (PrEP) IN UNDIAGNOSED EARLY HIV-1 INFECTION****1 INDICATIONS AND USAGE**

- 1.1 Treatment of HIV-1 Infection
- 1.2 HIV-1 Pre-Exposure Prophylaxis (PrEP)

2 DOSAGE AND ADMINISTRATION

- 2.1 Testing When Initiating and During Use of DESCOVY for Treatment of HIV-1 Infection or for HIV-1 PrEP
- 2.2 HIV-1 Screening for Individuals Receiving DESCOVY for HIV-1 PrEP
- 2.3 Recommended Dosage for Treatment of HIV-1 Infection in Adults and Pediatric Patients Weighing at Least 25 kg
- 2.4 Recommended Dosage for HIV-1 PrEP in Adults and Adolescents Weighing at Least 35 kg
- 2.5 Not Recommended in Individuals with Severe Renal Impairment for Treatment of HIV-1 Infection or for HIV-1 PrEP

3 DOSAGE FORMS AND STRENGTHS**4 CONTRAINDICATIONS****5 WARNINGS AND PRECAUTIONS**

- 5.1 Severe Acute Exacerbation of Hepatitis B in Individuals with HBV Infection
- 5.2 Comprehensive Management to Reduce the Risk of Sexually Transmitted Infections, Including HIV-1, and Development of HIV-1 Resistance When DESCOVY Is Used for HIV-1 PrEP
- 5.3 Immune Reconstitution Syndrome
- 5.4 New Onset or Worsening Renal Impairment
- 5.5 Lactic Acidosis/Severe Hepatomegaly with Steatosis

6 ADVERSE REACTIONS

- 6.1 Clinical Trials Experience
- 6.2 Postmarketing Experience

7 DRUG INTERACTIONS

- 7.1 Potential for Other Drugs to Affect One or More Components of DESCOVY
- 7.2 Drugs Affecting Renal Function
- 7.3 Established and Other Potentially Significant Interactions
- 7.4 Drugs without Clinically Significant Interactions with DESCOVY

8 USE IN SPECIFIC POPULATIONS

- 8.1 Pregnancy
- 8.2 Lactation
- 8.4 Pediatric Use
- 8.5 Geriatric Use
- 8.6 Renal Impairment
- 8.7 Hepatic Impairment

10 OVERDOSAGE**11 DESCRIPTION****12 CLINICAL PHARMACOLOGY**

- 12.1 Mechanism of Action
- 12.2 Pharmacodynamics
- 12.3 Pharmacokinetics
- 12.4 Microbiology

13 NONCLINICAL TOXICOLOGY

- 13.1 Carcinogenesis, Mutagenesis, Impairment of Fertility
- 13.2 Animal Toxicology and/or Pharmacology

14 CLINICAL STUDIES

- 14.1 Overview of Clinical Trials
- 14.2 Clinical Trial Results for Treatment of HIV-1
- 14.3 Clinical Trial Results for HIV-1 PrEP

16 HOW SUPPLIED/STORAGE AND HANDLING**17 PATIENT COUNSELING INFORMATION**

*Sections or subsections omitted from the full prescribing information are not listed.

FULL PRESCRIBING INFORMATION

WARNING: POST-TREATMENT ACUTE EXACERBATION OF HEPATITIS B and RISK OF DRUG RESISTANCE WITH USE OF DESCOVY FOR HIV-1 PRE-EXPOSURE PROPHYLAXIS (PrEP) IN UNDIAGNOSED EARLY HIV-1 INFECTION

Severe acute exacerbations of hepatitis B (HBV) have been reported in HBV-infected individuals who have discontinued products containing emtricitabine (FTC) and/or tenofovir disoproxil fumarate (TDF) and may occur with discontinuation of DESCOVY.

Hepatic function should be monitored closely with both clinical and laboratory follow-up for at least several months in individuals who are infected with HBV and discontinue DESCOVY. If appropriate, anti-hepatitis B therapy may be warranted [*see Warnings and Precautions (5.1)*].

DESCOVY used for HIV-1 PrEP must only be prescribed to individuals confirmed to be HIV-negative immediately prior to initiating and at least every 3 months during use. Drug-resistant HIV-1 variants have been identified with use of FTC/TDF for HIV-1 PrEP following undetected acute HIV-1 infection. Do not initiate DESCOVY for HIV-1 PrEP if signs or symptoms of acute HIV-1 infection are present unless negative infection status is confirmed [*see Warnings and Precautions (5.2)*].

1 INDICATIONS AND USAGE

1.1 Treatment of HIV-1 Infection

DESCOVY is indicated, in combination with other antiretroviral agents, for the treatment of HIV-1 infection in adults and pediatric patients weighing at least 35 kg.

DESCOVY is indicated, in combination with other antiretroviral agents other than protease inhibitors that require a CYP3A inhibitor, for the treatment of HIV-1 infection in pediatric patients weighing at least 25 kg and less than 35 kg.

1.2 HIV-1 Pre-Exposure Prophylaxis (PrEP)

DESCOVY is indicated in at-risk adults and adolescents weighing at least 35 kg for pre-exposure prophylaxis (PrEP) to reduce the risk of HIV-1 infection from sexual acquisition, excluding individuals at risk from receptive vaginal sex. Individuals must have a negative HIV-1 test immediately prior to initiating DESCOVY for HIV-1 PrEP [*see Dosage and Administration (2.2) and Warnings and Precautions (5.2)*].

Limitations of Use:

The indication does not include use of DESCOVY in individuals at risk of HIV-1 from receptive vaginal sex because effectiveness in this population has not been evaluated [see *Clinical Studies (14.3)*].

2 DOSAGE AND ADMINISTRATION

2.1 Testing When Initiating and During Use of DESCOVY for Treatment of HIV-1 Infection or for HIV-1 PrEP

Prior to or when initiating DESCOVY, test individuals for hepatitis B virus infection [see *Warnings and Precautions (5.1)*].

Prior to or when initiating DESCOVY, and during use of DESCOVY on a clinically appropriate schedule, assess serum creatinine, estimated creatinine clearance, urine glucose, and urine protein in all individuals. In individuals with chronic kidney disease, also assess serum phosphorus [see *Warnings and Precautions (5.4)*].

2.2 HIV-1 Screening for Individuals Receiving DESCOVY for HIV-1 PrEP

Screen all individuals for HIV-1 infection immediately prior to initiating DESCOVY for HIV-1 PrEP and at least once every 3 months while taking DESCOVY, and upon diagnosis of any other sexually transmitted infections (STIs) [see *Indications and Usage (1.2)*, *Contraindications (4)*, and *Warnings and Precautions (5.2)*].

If recent (<1 month) exposures to HIV-1 are suspected or clinical symptoms consistent with acute HIV-1 infection are present, use a test approved or cleared by the FDA as an aid in the diagnosis of acute or primary HIV-1 infection [see *Warnings and Precautions (5.2)*, *Use in Specific Populations (8.4)*, and *Clinical Studies (14.3)*].

2.3 Recommended Dosage for Treatment of HIV-1 Infection in Adults and Pediatric Patients Weighing at Least 25 kg

DESCOVY is a two-drug fixed dose combination product containing 200 mg of emtricitabine (FTC) and 25 mg of tenofovir alafenamide (TAF). The recommended dosage of DESCOVY for treatment of HIV-1 is one tablet taken orally once daily with or without food in:

- adults and pediatric patients with body weight at least 25 kg and creatinine clearance greater than or equal to 30 mL per minute; or
- adults with creatinine clearance below 15 mL per minute who are receiving chronic hemodialysis. On days of hemodialysis, administer the daily dose of DESCOVY after completion of hemodialysis treatment [see *Use in Specific Populations (8.6)* and *Clinical Pharmacology (12.3)*].

For specific dosing recommendations for coadministered third agents, refer to their respective prescribing information [see *Drug Interactions (7)*].

The safety and effectiveness of DESCOVY coadministered with an HIV-1 protease inhibitor that is administered with either ritonavir or cobicistat have not been established in:

- pediatric subjects weighing less than 35 kg; or
- adult subjects with creatinine clearance below 15 mL per minute, with or without hemodialysis.

2.4 Recommended Dosage for HIV-1 PrEP in Adults and Adolescents Weighing at Least 35 kg

The dosage of DESCOVY for HIV-1 PrEP is one tablet (containing 200 mg of FTC and 25 mg of TAF) once daily taken orally with or without food in HIV-1 uninfected:

- adults and adolescents weighing at least 35 kg and with a creatinine clearance greater than or equal to 30 mL per minute; or
- adults with creatinine clearance below 15 mL per minute who are receiving chronic hemodialysis. On days of hemodialysis, administer the daily dose of DESCOVY after completion of hemodialysis treatment [see *Indications and Usage (1.2) and Clinical Pharmacology (12.3)*].

2.5 Not Recommended in Individuals with Severe Renal Impairment for Treatment of HIV-1 Infection or for HIV-1 PrEP

DESCOVY is not recommended in individuals with:

- severe renal impairment (estimated creatinine clearance of 15 to below 30 mL per minute); or
- end stage renal disease (ESRD; estimated creatinine clearance below 15 mL per minute) who are not receiving chronic hemodialysis [see *Dosage and Administration (2.3, 2.4) and Use in Specific Populations (8.6)*].

3 DOSAGE FORMS AND STRENGTHS

Each DESCOVY tablet contains 200 mg of emtricitabine (FTC) and 25 mg of tenofovir alafenamide (TAF) (equivalent to 28 mg of tenofovir alafenamide fumarate). The tablets are blue, rectangular-shaped, film-coated, debossed with “GSI” on one side and “225” on the other side.

4 CONTRAINDICATIONS

DESCOVY for HIV-1 PrEP is contraindicated in individuals with unknown or positive HIV-1 status [see *Warnings and Precautions (5.2)*].

5 WARNINGS AND PRECAUTIONS

5.1 Severe Acute Exacerbation of Hepatitis B in Individuals with HBV Infection

All individuals should be tested for the presence of hepatitis B virus (HBV) before or when initiating DESCOVY [see *Dosage and Administration (2.1)*].

Severe acute exacerbations of hepatitis B (e.g., liver decompensation and liver failure) have been reported in HBV-infected individuals who have discontinued products containing FTC and/or tenofovir disoproxil fumarate (TDF) and may occur with discontinuation of DESCOVY. Individuals infected with HBV who discontinue DESCOVY should be closely monitored with both clinical and laboratory follow-up for at least several months after stopping treatment. If appropriate, anti-hepatitis B therapy may be warranted, especially in individuals with advanced liver disease or cirrhosis, since post-treatment exacerbation of hepatitis may lead to hepatic decompensation and liver failure. HBV-uninfected individuals should be offered vaccination.

5.2 Comprehensive Management to Reduce the Risk of Sexually Transmitted Infections, Including HIV-1, and Development of HIV-1 Resistance When DESCOVY Is Used for HIV-1 PrEP

Use DESCOVY for HIV-1 PrEP to reduce the risk of HIV-1 infection as part of a comprehensive prevention strategy, including adherence to daily administration and safer sex practices, including condoms, to reduce the risk of sexually transmitted infections (STIs). The time from initiation of DESCOVY for HIV-1 PrEP to maximal protection against HIV-1 infection is unknown.

Risk for HIV-1 acquisition includes behavioral, biological, or epidemiologic factors including but not limited to condomless sex, past or current STIs, self-identified HIV risk, having sexual partners of unknown HIV-1 viremic status, or sexual activity in a high prevalence area or network.

Counsel individuals on the use of other prevention measures (e.g., consistent and correct condom use, knowledge of partner(s)' HIV-1 status, including viral suppression status, regular testing for STIs that can facilitate HIV-1 transmission). Inform uninfected individuals about and support their efforts in reducing sexual risk behavior.

Use DESCOVY to reduce the risk of acquiring HIV-1 only in individuals confirmed to be HIV-1 negative. HIV-1 resistance substitutions may emerge in individuals with undetected HIV-1 infection who are taking only DESCOVY, because DESCOVY alone does not constitute a complete regimen for HIV-1 treatment [see *Microbiology (12.4)*]; therefore, care should be taken to minimize the risk of initiating or continuing DESCOVY before confirming the individual is HIV-1 negative.

- Some HIV-1 tests only detect anti-HIV antibodies and may not identify HIV-1 during the acute stage of infection. Prior to initiating DESCOVY for HIV-1

PrEP, ask seronegative individuals about recent (in past month) potential exposure events (e.g., condomless sex or condom breaking during sex with a partner of unknown HIV-1 status or unknown viremic status, or a recent STI), and evaluate for current or recent signs or symptoms consistent with acute HIV-1 infection (e.g., fever, fatigue, myalgia, skin rash).

- If recent (<1 month) exposures to HIV-1 are suspected or clinical symptoms consistent with acute HIV-1 infection are present, use a test approved or cleared by the FDA as an aid in the diagnosis of acute or primary HIV-1 infection.

While using DESCOVY for HIV-1 PrEP, HIV-1 testing should be repeated at least every 3 months, and upon diagnosis of any other STIs.

- If an HIV-1 test indicates possible HIV-1 infection, or if symptoms consistent with acute HIV-1 infection develop following a potential exposure event, convert the HIV-1 PrEP regimen to an HIV treatment regimen until negative infection status is confirmed using a test approved or cleared by the FDA as an aid in the diagnosis of acute or primary HIV-1 infection.

Counsel HIV-1 uninfected individuals to strictly adhere to the once daily DESCOVY dosing schedule. The effectiveness of DESCOVY in reducing the risk of acquiring HIV-1 is strongly correlated with adherence, as demonstrated by measurable drug levels in a clinical trial of DESCOVY for HIV-1 PrEP. Some individuals, such as adolescents, may benefit from more frequent visits and counseling to support adherence [see *Use in Specific Populations (8.4)*, *Microbiology (12.4)*, and *Clinical Studies (14.3)*].

5.3 Immune Reconstitution Syndrome

Immune reconstitution syndrome has been reported in HIV-1 infected patients treated with combination antiretroviral therapy, including FTC, a component of DESCOVY. During the initial phase of combination antiretroviral treatment, HIV-1 infected patients whose immune system responds may develop an inflammatory response to indolent or residual opportunistic infections (such as *Mycobacterium avium* infection, cytomegalovirus, *Pneumocystis jirovecii* pneumonia [PCP], or tuberculosis), which may necessitate further evaluation and treatment.

Autoimmune disorders (such as Graves' disease, polymyositis, Guillain-Barré syndrome, and autoimmune hepatitis) have also been reported to occur in the setting of immune reconstitution; however, the time to onset is more variable, and can occur many months after initiation of treatment.

5.4 New Onset or Worsening Renal Impairment

Renal impairment, including cases of acute renal failure and Fanconi syndrome (renal tubular injury with severe hypophosphatemia), has been reported with the use of tenofovir prodrugs in both animal toxicology studies and human trials. In clinical trials of FTC+TAF with cobicistat (COBI) plus elvitegravir (EVG) in HIV-1 infected patients there have been no cases of Fanconi syndrome or Proximal

Renal Tubulopathy (PRT). In clinical trials of FTC+TAF with EVG+COBI in treatment-naïve subjects and in virally suppressed subjects switched to FTC+TAF with EVG+COBI with estimated creatinine clearance greater than 50 mL per minute, renal serious adverse events or discontinuations due to renal adverse reactions were encountered in less than 1% of participants treated with FTC+TAF with EVG+COBI. In a study of virally suppressed subjects with baseline estimated creatinine clearance between 30 and 69 mL per minute treated with FTC+TAF with EVG+COBI for a median duration of 43 weeks, FTC+TAF with EVG+COBI was permanently discontinued due to worsening renal function in two of 80 (3%) subjects with a baseline estimated creatinine clearance between 30 and 50 mL per minute [see *Adverse Reactions (6.1)*]. DESCOVY is not recommended in individuals with estimated creatinine clearance of 15 to below 30 mL per minute, or in individuals with estimated creatinine clearance below 15 mL per minute who are not receiving chronic hemodialysis.

Individuals taking tenofovir prodrugs who have impaired renal function and those taking nephrotoxic agents including non-steroidal anti-inflammatory drugs are at increased risk of developing renal-related adverse reactions.

Prior to or when initiating DESCOVY, and during treatment with DESCOVY on a clinically appropriate schedule, assess serum creatinine, estimated creatinine clearance, urine glucose, and urine protein in all individuals. In individuals with chronic kidney disease, also assess serum phosphorus. Discontinue DESCOVY in individuals who develop clinically significant decreases in renal function or evidence of Fanconi syndrome.

5.5 Lactic Acidosis/Severe Hepatomegaly with Steatosis

Lactic acidosis and severe hepatomegaly with steatosis, including fatal cases, have been reported with the use of nucleoside analogs, including emtricitabine, a component of DESCOVY, and tenofovir DF, another prodrug of tenofovir, alone or in combination with other antiretrovirals. Treatment with DESCOVY should be suspended in any individual who develops clinical or laboratory findings suggestive of lactic acidosis or pronounced hepatotoxicity (which may include hepatomegaly and steatosis even in the absence of marked transaminase elevations).

6 ADVERSE REACTIONS

The following adverse reactions are discussed in other sections of the labeling:

- Severe Acute Exacerbations of Hepatitis B [see *Warnings and Precautions (5.1)*].
- Immune Reconstitution Syndrome [see *Warnings and Precautions (5.3)*].
- New Onset or Worsening Renal Impairment [see *Warnings and Precautions (5.4)*].

- Lactic Acidosis/Severe Hepatomegaly with Steatosis [see *Warnings and Precautions* (5.5)].

6.1 Clinical Trials Experience

Because clinical trials are conducted under widely varying conditions, adverse reaction rates observed in the clinical trials of a drug (or a drug given in various combinations with other concomitant therapy) cannot be directly compared to rates in the clinical trials of another drug (or drug given in the same or different combination therapy) and may not reflect the rates observed in practice.

Adverse Reactions in Clinical Trials of FTC+TAF with EVG+COBI in Treatment-Naïve Adults with HIV-1 Infection

In pooled 48-week trials of antiretroviral treatment-naïve HIV-1 infected adult subjects, the most common adverse reaction in subjects treated with FTC+TAF with EVG+COBI (N=866) (incidence greater than or equal to 10%, all grades) was nausea (10%). In this treatment group, 0.9% of subjects discontinued FTC+TAF with EVG+COBI due to adverse events during the 48-week treatment period [see *Clinical Studies* (14.2)]. The safety profile was similar in virologically-suppressed adults with HIV-1 infection who were switched to FTC+TAF with EVG+COBI (N=799). Antiretroviral treatment-naïve adult subjects treated with FTC+TAF with EVG+COBI experienced mean increases of 30 mg/dL of total cholesterol, 15 mg/dL of LDL cholesterol, 7 mg/dL of HDL cholesterol, and 29 mg/dL of triglycerides after 48 weeks of use.

Renal Laboratory Tests

In two 48-week trials in antiretroviral treatment-naïve HIV-1 infected adults treated with FTC+TAF with EVG+COBI (N=866) with a median baseline eGFR of 115 mL per minute, mean serum creatinine increased by 0.1 mg per dL from baseline to Week 48. Median urine protein-to-creatinine ratio (UPCR) was 44 mg per gram at baseline and at Week 48. In a 48-week trial in virologically-suppressed TDF-treated adults who switched to FTC+TAF with EVG+COBI (N=959) with a mean baseline eGFR of 112 mL per minute, mean serum creatinine was similar to baseline at Week 48; median UPCR was 61 mg per gram at baseline and 46 mg per gram at Week 48. In a 24-week trial in adults with renal impairment (baseline eGFR 30 to 69 mL per minute) who received FTC+TAF with EVG+COBI (N=248), mean serum creatinine was 1.5 mg per dL at both baseline and Week 24. Median UPCR was 161 mg per gram at baseline and 93 mg per gram at Week 24.

Bone Mineral Density Effects

In the pooled analysis of two 48-week trials of antiretroviral treatment-naïve HIV-1 infected adult subjects, bone mineral density (BMD) from baseline to Week 48 was assessed by dual-energy X-ray absorptiometry (DXA). Mean BMD decreased from baseline to Week 48 -1.30% with FTC+TAF with EVG+COBI at the lumbar spine and -0.66% at the total hip. BMD declines of 5% or greater at

the lumbar spine were experienced by 10% of FTC+TAF with EVG+COBI subjects. BMD declines of 7% or greater at the femoral neck were experienced by 7% of FTC+TAF with EVG+COBI subjects. The long-term clinical significance of these BMD changes is not known.

In 799 virologically-suppressed TDF-treated adult subjects that switched to FTC+TAF with EVG+COBI, at Week 48 mean BMD increased (1.86% lumbar spine, 1.95% total hip). BMD declines of 5% or greater at the lumbar spine were experienced by 1% of FTC+TAF with EVG+COBI subjects. BMD declines of 7% or greater at the femoral neck were experienced by 1% of FTC+TAF with EVG+COBI subjects.

Adverse Reactions in a Clinical Trial of FTC+TAF with EVG+COBI in Virologically-Suppressed Adults with End Stage Renal Disease (ESRD) Receiving Chronic Hemodialysis

In a 48-week trial of virologically-suppressed HIV-1 infected adult subjects with end stage renal disease (ESRD) (estimated creatinine clearance of less than 15 mL/min) on chronic hemodialysis treated with FTC+TAF with EVG+COBI (N=55), the most commonly reported adverse reaction (adverse event assessed as causally related by investigator and all grades) was nausea (7%). Serious adverse events were reported in 53% of subjects and the most common serious adverse events were pneumonia (13%), fluid overload (7%), hyperkalemia (7%) and osteomyelitis (7%). Overall 5% of subjects permanently discontinued treatment due to an adverse event.

Adverse Reactions in Clinical Trials in Pediatric Subjects with HIV-1 Infection

In an open-label trial of antiretroviral treatment-naïve HIV-1 infected pediatric subjects between the ages of 12 to less than 18 years weighing at least 35 kg through 48 weeks (N=50; Cohort 1) and virologically-suppressed subjects between the ages of 6 to less than 12 years weighing at least 25 kg (N=23; Cohort 2) who received FTC+TAF with EVG+COBI through 24 weeks, with the exception of a decrease in the mean CD4+ cell count observed in cohort 2, the safety of this combination was similar to that of adults.

Bone Mineral Density Effects

Cohort 1: Treatment-naïve adolescents (12 to less than 18 years; at least 35 kg)

Among the subjects in cohort 1 receiving FTC+TAF with EVG+COBI, mean BMD increased from baseline to Week 48, +4.2% at the lumbar spine and +1.3% for the total body less head (TBLH). Mean changes from baseline BMD Z-scores were -0.07 for lumbar spine and -0.20 for TBLH at Week 48. One subject had significant (at least 4%) lumbar spine BMD loss at Week 48.

Cohort 2: Virologically-suppressed children (6 to less than 12 years; at least 25 kg)

Among the subjects in cohort 2 receiving FTC+TAF with EVG+COBI, mean BMD increased from baseline to Week 24, +2.9% at the lumbar spine and +1.7% for TBLH. Mean changes from baseline BMD Z-scores were -0.06 for lumbar spine and -0.18 for TBLH at Week 24. Two subjects had significant (at least 4%) lumbar spine BMD loss at Week 24.

Change from Baseline in CD4+ cell counts

Cohort 2: Virologically-suppressed children (6 to less than 12 years; at least 25 kg)

Cohort 2 evaluated pediatric subjects (N=23) who were virologically-suppressed and who switched from their antiretroviral regimen to FTC+TAF with EVG+COBI. Although all subjects had HIV-1 RNA < 50 copies/mL, there was a decrease from baseline in CD4+ cell count at Week 24. The mean baseline and mean change from baseline in CD4+ cell count and in CD4% from Week 2 to Week 24 are presented in Table 1. All subjects maintained their CD4+ cell counts above 400 cells/mm³ [see Use in Specific Populations (8.4)].

Table 1 Mean Change in CD4+ Count and Percentage from Baseline to Week 24 in Virologically-Suppressed Pediatric Patients from 6 to <12 Years Who Switched to FTC+TAF with EVG+COBI

	Baseline	Mean Change from Baseline			
		Week 2	Week 4	Week 12	Week 24
CD4+ Cell Count (cells/mm ³)	966 (201.7) ^a	-162	-125	-162	-150
CD4%	40 (5.3) ^a	+0.5%	-0.1%	-0.8%	-1.5%

a. Mean (SD)

Adverse Reactions from Clinical Trial Experience in HIV-1 Uninfected Individuals Taking DESCovy for HIV-1 PrEP

The safety profile of DESCovy for HIV-1 PrEP was comparable to that observed in clinical trials of HIV-infected subjects based on a double-blind, randomized, active-controlled trial (DISCOVER) in which a total of 5,387 HIV-1 uninfected adult men and transgender women who have sex with men received DESCovy (N=2,694) or TRUVADA (N=2,693) once daily for HIV-1 PrEP [see *Clinical Studies (14.3)*]. Median duration of exposure was 86 and 87 weeks, respectively. The most common adverse reaction in participants who received DESCovy (incidence greater than or equal to 5%, all grades) was diarrhea (5%). Table 2 provides a list of the most common adverse reactions that occurred in 2% or more of participants in either treatment group. The proportion of participants who discontinued treatment with DESCovy or TRUVADA due to adverse events, regardless of severity, was 1.3% and 1.8%, respectively.

Table 2 Adverse Reactions (All Grades) Reported in $\geq 2\%$ in Either Arm in the DISCOVER Trial of HIV-1 Uninfected Participants

	DESCOVY (N=2,694)	TRUVADA (N=2,693)
Diarrhea	5%	6%
Nausea	4%	5%
Headache	2%	2%
Fatigue	2%	3%
Abdominal pain ^a	2%	3%

a. Includes the following terms: abdominal pain, abdominal pain upper, abdominal pain lower, gastrointestinal pain, and abdominal discomfort

Renal Laboratory Tests

Changes from baseline to Week 48 in renal laboratory data are presented in Table 3. The long-term clinical significance of these renal laboratory changes on adverse reaction frequencies between DESCOVY and TRUVADA is not known.

Table 3 Laboratory Assessments of Renal Function Reported in HIV-1 Uninfected Participants Receiving DESCOVY or TRUVADA in the DISCOVER Trial

	DESCOVY (N=2,694)	TRUVADA (N=2,693)
Serum Creatinine (mg/dL) ^a Change at Week 48	-0.01 (0.107)	0.01 (0.111)
eGFR _{CG} (mL/min) ^b Change at Week 48	1.8 (-7.2, 11.1)	-2.3 (-10.8, 7.2)
Percentage of Participants who Developed UPCR >200 mg/g ^c At Week 48	0.7%	1.5%

eGFR_{CG}=estimated Glomerular Filtration Rate by Cockcroft-Gault; UPCR=urine protein/creatinine ratio

a. Mean (SD).

b. Median (Q1, Q3).

c. Based on N who had normal UPCR (≤ 200 mg/g) at baseline.

Bone Mineral Density Effects

In the DISCOVER trial, mean increases from baseline to Week 48 of 0.5% at the lumbar spine (N=159) and 0.2% at the total hip (N=158) were observed in participants receiving DESCOVY, compared to mean decreases of 1.1% at the lumbar spine (N=160) and 1.0% at the total hip (N=158) in participants receiving TRUVADA. BMD declines of 5% or greater at the lumbar spine and 7% or greater at the total hip were experienced by 4% and 1% of participants, respectively, in both treatment groups at Week 48. The long-term clinical significance of these BMD changes is not known.

Serum Lipids

Changes from baseline to Week 48 in total cholesterol, HDL-cholesterol, LDL-cholesterol, triglycerides, and total cholesterol to HDL ratio are presented in Table 4.

Table 4 Fasting Lipid Values, Mean Change from Baseline, Reported in HIV-1 Uninfected Participants Receiving DESCOVY or TRUVADA in the DISCOVER Trial^a

	DESCOVY (N=2,694)		TRUVADA (N=2,693)	
	Baseline	Week 48	Baseline	Week 48
	mg/dL	Change ^b	mg/dL	Change ^b
Total Cholesterol (fasted)	176 ^c	0 ^c	176 ^d	-12 ^d
HDL-Cholesterol (fasted)	51 ^c	-2 ^c	51 ^d	-5 ^d
LDL-Cholesterol (fasted)	103 ^e	0 ^e	103 ^f	-7 ^f
Triglycerides (fasted)	109 ^c	+9 ^c	111 ^d	-1 ^d
Total Cholesterol to HDL ratio	3.7 ^c	0.2 ^c	3.7 ^d	0.1 ^d

a. Excludes subjects who received lipid lowering agents during the treatment period.

b. The baseline and change from baseline are for subjects with both baseline and Week 48 values.

c. N=1,098

d. N=1,124

e. N=1,079

f. N=1,107

6.2 Postmarketing Experience

The following adverse reactions have been identified during post-approval use of products containing TAF. Because these reactions are reported voluntarily from a population of uncertain size, it is not always possible to reliably estimate their frequency or establish a causal relationship to drug exposure.

Skin and Subcutaneous Tissue Disorders
Angioedema, urticaria, and rash

7 DRUG INTERACTIONS

7.1 Potential for Other Drugs to Affect One or More Components of DESCOVY

TAF, a component of DESCOVY, is a substrate of P-gp, BCRP, OATP1B1, and OATP1B3. Drugs that strongly affect P-gp and BCRP activity may lead to changes in TAF absorption (see Table 5). Drugs that induce P-gp activity are expected to decrease the absorption of TAF, resulting in decreased plasma concentration of TAF, which may lead to loss of therapeutic effect of DESCOVY and development of resistance. Coadministration of DESCOVY with other drugs

that inhibit P-gp and BCRP may increase the absorption and plasma concentration of TAF. TAF is not an inhibitor of CYP1A2, CYP2B6, CYP2C8, CYP2C9, CYP2C19, CYP2D6, or UGT1A1. TAF is a weak inhibitor of CYP3A *in vitro*. TAF is not an inhibitor or inducer of CYP3A *in vivo*.

7.2 Drugs Affecting Renal Function

Because FTC and tenofovir are primarily excreted by the kidneys by a combination of glomerular filtration and active tubular secretion, coadministration of DESCOVY with drugs that reduce renal function or compete for active tubular secretion may increase concentrations of FTC, tenofovir, and other renally eliminated drugs and this may increase the risk of adverse reactions. Some examples of drugs that are eliminated by active tubular secretion include, but are not limited to, acyclovir, cidofovir, ganciclovir, valacyclovir, valganciclovir, aminoglycosides (e.g., gentamicin), and high-dose or multiple NSAIDs [see *Warnings and Precautions (5.4)*].

7.3 Established and Other Potentially Significant Interactions

Table 5 provides a listing of established or potentially clinically significant drug interactions with recommended steps to prevent or manage the drug interaction (the table is not all inclusive). The drug interactions described are based on studies conducted with either DESCOVY, the components of DESCOVY (emtricitabine and tenofovir alafenamide) as individual agents, or are predicted drug interactions that may occur with DESCOVY. For magnitude of interaction, see *Clinical Pharmacology (12.3)*.

Table 5 Established and Other Potentially Significant^a Drug Interactions

Concomitant Drug Class: Drug Name	Effect on Concentration^b	Clinical Comment
Antiretroviral Agents: Protease Inhibitors (PI)		
tipranavir/ritonavir	↓ TAF	Coadministration with DESCOVY is not recommended.
Other Agents		
Anticonvulsants: carbamazepine oxcarbazepine phenobarbital phenytoin	↓ TAF	Consider alternative anticonvulsant.
Antimycobacterials : rifabutin rifampin rifapentine	↓ TAF	Coadministration of DESCOVY with rifabutin, rifampin, or rifapentine is not recommended.
Herbal Products: St. John's wort (<i>Hypericum perforatum</i>)	↓ TAF	Coadministration of DESCOVY with St. John's wort is not recommended.

- a. This table is not all inclusive.
b. ↓=Decrease

7.4 Drugs without Clinically Significant Interactions with DESCOVY

Based on drug interaction studies conducted with the components of DESCOVY, no clinically significant drug interactions have been either observed or are expected when DESCOVY is combined with the following antiretroviral agents: atazanavir with ritonavir or cobicistat, darunavir with ritonavir or cobicistat, dolutegravir, efavirenz, ledipasvir, lopinavir/ritonavir, maraviroc, nevirapine, raltegravir, rilpivirine, and sofosbuvir. No clinically significant drug interactions have been either observed or are expected when DESCOVY is combined with the following drugs: buprenorphine, itraconazole, ketoconazole, lorazepam, methadone, midazolam, naloxone, norbuprenorphine, norgestimate/ethinyl estradiol, and sertraline.

8 USE IN SPECIFIC POPULATIONS

8.1 Pregnancy

Pregnancy Exposure Registry

There is a pregnancy exposure registry that monitors pregnancy outcomes in individuals exposed to DESCOVY during pregnancy. Healthcare providers are encouraged to register patients by calling the Antiretroviral Pregnancy Registry (APR) at 1-800-258-4263.

Risk Summary

Available data from the APR show no increase in the risk of overall major birth defects for emtricitabine (FTC) compared with the background rate for major birth defects of 2.7% in a U.S. reference population of the Metropolitan Atlanta Congenital Defects Program (MACDP). There are insufficient tenofovir alafenamide (TAF) data from the APR to adequately assess the risk of major birth defects. The rate of miscarriage for individual drugs is not reported in the APR. The estimated background rate of miscarriage in the clinically recognized pregnancies in the U.S. general population is 15–20%.

In animal studies, no adverse developmental effects were observed when the components of DESCOVY were administered separately during the period of organogenesis at exposures 60 and 108 times (mice and rabbits, respectively) the FTC exposure and at exposure equal to or 53 times (rats and rabbits, respectively) the TAF exposure at the recommended daily dose of DESCOVY (*see Data*). Likewise, no adverse developmental effects were seen when FTC was administered to mice through lactation at exposures up to approximately 60 times the exposure at the recommended daily dose of DESCOVY. No adverse effects were observed in the offspring when TDF was administered through lactation at tenofovir exposures of approximately 14 times the exposure at the recommended daily dosage of DESCOVY.

Data

Human Data

Emtricitabine: Based on prospective reports to the APR through January 2019 of over 4,450 exposures to FTC-containing regimens during pregnancy (including over 3,150 exposed in the first trimester and over 1,300 exposed in the second/third trimester), there was no difference between FTC and overall birth defects compared with the background birth defect rate of 2.7% in the U.S. reference population of the MACDP. The prevalence of birth defects in live births was 2.4% (95% CI: 1.9% to 3.0%) with first trimester exposure to FTC-containing regimens and 2.3% (95% CI: 1.5% to 3.2%) with the second/third trimester exposure to FTC-containing regimens.

Tenofovir Alafenamide: Based on prospective reports to the APR of over 220 exposures to TAF-containing regimens during pregnancy (including over 160 exposed in the first trimester and over 60 exposed in the second/third trimester), there have been 6 birth defects with first trimester exposure to TAF-containing regimens.

Methodologic limitations of the APR include the use of MACDP as the external comparator group. The MACDP population is not disease-specific, evaluates women and infants from a limited geographic area, and does not include outcomes for births that occurred at <20 weeks gestation.

Additionally, published observational studies on emtricitabine and tenofovir exposure in pregnancy have not shown an increased risk for major malformations.

Animal Data

Emtricitabine: FTC was administered orally to pregnant mice (250, 500, or 1000 mg/kg/day) and rabbits (100, 300, or 1000 mg/kg/day) through organogenesis (on gestation days 6 through 15, and 7 through 19, respectively). No significant toxicological effects were observed in embryo-fetal toxicity studies performed with FTC in mice at exposures (area under the curve [AUC]) approximately 60 times higher and in rabbits at approximately 108 times higher than human exposures at the recommended daily dose. In a pre/postnatal development study with FTC, mice were administered doses up to 1000 mg/kg/day; no significant adverse effects directly related to drug were observed in the offspring exposed daily from before birth (*in utero*) through sexual maturity at daily exposures (AUC) of approximately 60-fold higher than human exposures at the recommended daily dose.

Tenofovir Alafenamide: TAF was administered orally to pregnant rats (25, 100, or 250 mg/kg/day) and rabbits (10, 30, or 100 mg/kg/day) through organogenesis (on gestation days 6 through 17, and 7 through 20, respectively). No adverse embryo-fetal effects were observed in rats and rabbits at TAF exposures approximately similar to (rats) and 53 (rabbits) times higher than the exposure in humans at the recommended daily dose of DESCOVY. TAF is rapidly converted to tenofovir; the observed tenofovir exposures in rats and rabbits were 59 (rats) and 93 (rabbits) times higher than human tenofovir exposures at the recommended daily dose. Since TAF is rapidly converted to tenofovir and a lower tenofovir exposure in rats and mice was observed after TAF administration compared to tenofovir disoproxil fumarate (TDF, another prodrug for tenofovir) administration, a pre/postnatal development study in rats was conducted only with TDF. Doses up to 600 mg/kg/day were administered through lactation; no adverse effects were observed in the offspring on gestation day 7 (and lactation day 20) at tenofovir exposures of approximately 14 (21) times higher than the exposures in humans at the recommended daily dose of DESCOVY.

8.2 Lactation

Risk Summary

The Centers for Disease Control and Prevention recommend that HIV-infected mothers not breastfeed their infants, to avoid risking postnatal transmission of HIV-1.

Based on limited data, FTC has been shown to be present in human breast milk; it is not known if TAF is present in human breast milk. Tenofovir has been shown to be present in the milk of lactating rats and rhesus monkeys after administration of TDF (*see Data*). It is not known if TAF is present in animal milk.

It is not known if DESCOVY affects milk production or has effects on the breastfed child.

Because of the potential for: 1) HIV transmission (in HIV-negative infants); 2) developing viral resistance (in HIV-positive infants); and 3) adverse reactions in a

breastfed infant similar to those seen in adults, instruct mothers not to breastfeed if they are taking DESCOVY for the treatment of HIV-1 (see *Data*).

Data

Animal Data

Tenofovir Alafenamide: Studies in rats and monkeys have demonstrated that tenofovir is secreted in milk. Tenofovir was excreted into the milk of lactating rats following oral administration of TDF (up to 600 mg/kg/day) at up to approximately 24% of the median plasma concentration in the highest dosed animals at lactation day 11. Tenofovir was excreted into the milk of lactating monkeys following a single subcutaneous (30 mg/kg) dose of tenofovir at concentrations up to approximately 4% of plasma concentration, resulting in exposure (AUC) of approximately 20% of plasma exposure.

8.4 Pediatric Use

Treatment of HIV-1 Infection

The safety and effectiveness of DESCOVY, in combination with other antiretroviral agents, for the treatment of HIV-1 infection was established in pediatric patients with body weight greater than or equal to 25 kg [see *Indication and Usage (1.1)* and *Dosage and Administration (2.3)*].

Use of DESCOVY in pediatric patients between the ages of 12 to less than 18 years weighing at least 35 kg is supported by adequate and well controlled studies of FTC+TAF with EVG+COBI in adults and by an open-label trial in antiretroviral treatment-naïve HIV-1 infected pediatric subjects ages 12 to less than 18 years and weighing at least 35 kg (N=50; cohort 1). The safety and efficacy of FTC+TAF with EVG+COBI in these pediatric subjects was similar to that of HIV-1 infected adults on this regimen [see *Clinical Pharmacology (12.3)* and *Clinical Studies (14.2)*].

Use of DESCOVY in pediatric patients weighing at least 25 kg is supported by adequate and well controlled studies of FTC+TAF with EVG+COBI in adults and by an open-label trial in virologically-suppressed pediatric subjects between the ages of 6 to less than 12 years weighing at least 25 kg, in which subjects were switched from their antiretroviral regimen to FTC+TAF with EVG+COBI (N=23; cohort 2). The safety in these subjects through 24 weeks of FTC+TAF with EVG+COBI was similar to that of HIV-1 infected adults on this regimen, with the exception of a decrease in mean change from baseline in CD4+ cell count [see *Adverse Reactions (6.1)*, *Clinical Pharmacology (12.3)* and *Clinical Studies (14.2)*].

Safety and effectiveness of DESCOVY coadministered with an HIV-1 protease inhibitor that is administered with either ritonavir or cobicistat have not been established in pediatric subjects weighing less than 35 kg [see *Dosage and Administration (2.3)*].

Safety and effectiveness of DESCOVY for treatment of HIV-1 infection in pediatric patients less than 25 kg have not been established.

HIV-1 PrEP

Safety and effectiveness of DESCOVY for HIV-1 PrEP in at-risk adolescents weighing at least 35 kg, excluding individuals at risk from receptive vaginal sex, is supported by data from an adequate and well-controlled trial of DESCOVY for HIV-1 PrEP in adults with additional data from safety and pharmacokinetic studies in previously conducted trials with the individual drug products, FTC and TAF, with EVG+COBI, in HIV-1 infected adults and pediatric subjects [see *Dosage and Administration (2.4)*, *Adverse Reactions (6.1)*, *Clinical Pharmacology (12.3 and 12.4)*, and *Clinical Studies (14)*].

While using DESCOVY for HIV-1 PrEP, HIV-1 testing should be repeated at least every 3 months, and upon diagnosis of any other STIs. Previous studies in at-risk adolescents indicated waning adherence to a daily oral PrEP regimen once visits were switched from monthly to quarterly visits. Adolescents may therefore benefit from more frequent visits and counseling [see *Warnings and Precautions (5.2)*].

Safety and effectiveness of DESCOVY for HIV-1 PrEP in pediatric patients less than 35 kg have not been established.

8.5 Geriatric Use

In clinical trials of an FTC+TAF-containing regimen for treatment of HIV-1, 80 of the 97 subjects enrolled aged 65 years and over received FTC+TAF and EVG+COBI. No differences in safety or efficacy have been observed between elderly subjects and adults between 18 and less than 65 years of age.

8.6 Renal Impairment

No dosage adjustment of DESCOVY is recommended in individuals with estimated creatinine clearance greater than or equal to 30 mL per minute, or in adults with ESRD (estimated creatinine clearance below 15 mL per minute) who are receiving chronic hemodialysis. On days of hemodialysis, administer the daily dose of DESCOVY after completion of hemodialysis treatment.

Safety and effectiveness of DESCOVY coadministered with an HIV-1 protease inhibitor that is administered with either ritonavir or cobicistat have not been established in patients with ESRD [see *Dosage and Administration (2.3)*].

DESCOVY is not recommended in individuals with severe renal impairment (estimated creatinine clearance of 15 to below 30 mL per minute), or in individuals with ESRD who are not receiving chronic hemodialysis, as the safety of DESCOVY has not been established in these populations [see *Dosage and Administration (2.5)* and *Clinical Studies (14.2)*].

8.7 Hepatic Impairment

No dosage adjustment of DESCOVY is recommended in individuals with mild (Child-Pugh Class A) or moderate (Child-Pugh Class B) hepatic impairment.

DESCOVY has not been studied in individuals with severe hepatic impairment (Child-Pugh Class C) [see *Clinical Pharmacology* (12.3)].

10 OVERDOSAGE

No data are available on overdose of DESCOVY in patients. If overdose occurs, monitor the individual for evidence of toxicity. Treatment of overdose with DESCOVY consists of general supportive measures including monitoring of vital signs as well as observation of the clinical status of the individual.

Emtricitabine (FTC): Limited clinical experience is available at doses higher than the recommended dose of FTC in DESCOVY. In one clinical pharmacology study, single doses of FTC 1200 mg (6 times the FTC dose in DESCOVY) were administered to 11 subjects. No severe adverse reactions were reported. The effects of higher doses are not known.

Hemodialysis treatment removes approximately 30% of the FTC dose over a 3-hour dialysis period starting within 1.5 hours of FTC dosing (blood flow rate of 400 mL per minute and a dialysate flow rate of 600 mL per minute). It is not known whether FTC can be removed by peritoneal dialysis.

Tenofovir Alafenamide (TAF): Limited clinical experience is available at doses higher than the recommended dose of TAF. A single dose of 125 mg TAF (5 times the TAF dose in 200/25 mg DESCOVY) was administered to 48 healthy subjects; no serious adverse reactions were reported. The effects of higher doses are unknown. Tenofovir is efficiently removed by hemodialysis with an extraction coefficient of approximately 54%.

11 DESCRIPTION

DESCOVY (emtricitabine and tenofovir alafenamide) is a fixed dose combination tablet containing emtricitabine (FTC) and tenofovir alafenamide (TAF) for oral administration.

- FTC, a synthetic nucleoside analog of cytidine, is an HIV nucleoside analog reverse transcriptase inhibitor (HIV NRTI).
- TAF, an HIV NRTI, is converted in vivo to tenofovir, an acyclic nucleoside phosphonate (nucleotide) analog of adenosine 5'-monophosphate.

Each 200/25 mg tablet contains 200 mg of FTC and 25 mg of TAF (equivalent to 28 mg of tenofovir alafenamide fumarate) and the following inactive ingredients: croscarmellose sodium, magnesium stearate, and microcrystalline cellulose. The tablets are film-coated with a coating material containing indigo carmine aluminum lake, polyethylene glycol, polyvinyl alcohol, talc, and titanium dioxide.

Emtricitabine: The chemical name of FTC is 4-amino-5-fluoro-1-(2*R*-hydroxymethyl-1,3-oxathiolan-5*S*-yl)-(1*H*)-pyrimidin-2-one. FTC is the (-)-enantiomer of a thio analog of cytidine, which differs from other cytidine analogs in that it has a fluorine in the 5 position.

FTC has a molecular formula of $C_8H_{10}FN_3O_3S$ and a molecular weight of 247.24 and has the following structural formula:

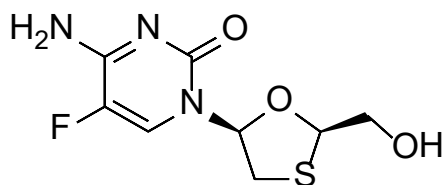

FTC is a white to off-white powder with a solubility of approximately 112 mg per mL in water at 25 °C.

Tenofovir Alafenamide: The chemical name of tenofovir alafenamide fumarate drug substance is L-alanine, *N*-[*(S)*-[[*(1R)*]-2-(6-amino-9*H*-purin-9-yl)-1-methylethoxy]methyl]phenoxyphosphinyl]-, 1-methylethyl ester, (*2E*)-2-butenedioate (2:1).

Tenofovir alafenamide fumarate has an empirical formula of $C_{21}H_{29}O_5N_6P \cdot \frac{1}{2}(C_4H_4O_4)$ and a formula weight of 534.50 and has the following structural formula:

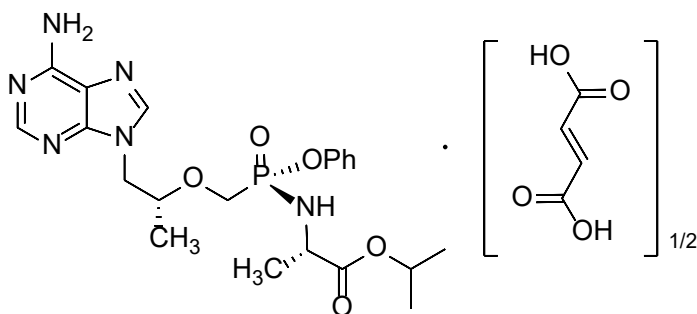

Tenofovir alafenamide fumarate is a white to off-white or tan powder with a solubility of 4.7 mg per mL in water at 20 °C.

12 CLINICAL PHARMACOLOGY

12.1 Mechanism of Action

DESCOVY is a fixed dose combination of antiretroviral drugs emtricitabine (FTC) and tenofovir alafenamide (TAF) [see *Microbiology* (12.4)].

12.2 Pharmacodynamics

Cardiac Electrophysiology

In a thorough QT/QTc study in 48 healthy subjects, TAF at the recommended dose or at a dose approximately 5 times the recommended dose, did not affect the QT/QTc interval and did not prolong the PR interval. The effect of the other component of DESCOVY, FTC, or the combination of FTC and TAF on the QT interval is not known.

12.3 Pharmacokinetics

Absorption, Distribution, Metabolism, and Excretion

The pharmacokinetic (PK) properties of the components of DESCOVY are provided in Table 6. The multiple dose PK parameters of FTC and TAF and its metabolite tenofovir are provided in Table 7. HIV status has no effect on the pharmacokinetics of FTC and TAF in adults.

Table 6 Pharmacokinetic Properties of the Components of DESCOVY

	Emtricitabine	Tenofovir Alafenamide
Absorption		
T _{max} (h)	3	1
Effect of high fat meal (relative to fasting) ^a	AUC Ratio = 0.91 (0.89, 0.93) C _{max} Ratio = 0.74 (0.69, 0.78)	AUC Ratio = 1.75 (1.64, 1.88) C _{max} Ratio = 0.85 (0.75, 0.95)
Distribution		
% Bound to human plasma proteins	<4	~80
Source of protein binding data	<i>In vitro</i>	<i>Ex vivo</i>
Blood-to-plasma ratio	0.6	1.0
Metabolism		
Metabolism	Not significantly metabolized	Cathepsin A ^b (PBMCs) CES1 (hepatocytes) CYP3A (minimal)
Elimination		
Major route of elimination	Glomerular filtration and active tubular secretion	Metabolism (>80% of oral dose)
t _{1/2} (h) ^c	10	0.51
% Of dose excreted in urine ^d	70	<1
% Of dose excreted in feces ^d	13.7	31.7

PBMCs=peripheral blood mononuclear cells; CES1=carboxylesterase 1

a. Values refer to geometric mean ratio [High-fat meal/ fasting] in PK parameters and (90% confidence interval). High-calorie/high-fat meal = ~800 kcal, 50% fat.

b. *In vivo*, TAF is hydrolyzed within cells to form tenofovir (major metabolite), which is phosphorylated to the active metabolite, tenofovir diphosphate. *In vitro* studies have shown that TAF is metabolized to tenofovir by cathepsin A in PBMCs and macrophages; and by CES1 in hepatocytes. Upon coadministration with the moderate CYP3A inducer probe efavirenz, TAF exposure was unaffected.

c. t_{1/2} values refer to median terminal plasma half-life. Note that the pharmacologically active metabolite, tenofovir diphosphate, has a half-life of 150-180 hours within PBMCs.

d. Dosing in mass balance studies: FTC (single dose administration of [¹⁴C] emtricitabine after multiple dosing of emtricitabine for 10 days); TAF (single dose administration of [¹⁴C] tenofovir alafenamide).

Table 7 Multiple Dose PK Parameters of Emtricitabine, Tenofovir Alafenamide and its Metabolite Tenofovir Following Oral Administration with Food in HIV-Infected Adults

Parameter Mean (CV%)	Emtricitabine ^a	Tenofovir Alafenamide ^b	Tenofovir ^c
C _{max} (microgram per mL)	2.1 (20.2)	0.16 (51.1)	0.02 (26.1)
AUC _{tau} (microgram•hour per mL)	11.7 (16.6)	0.21 (71.8)	0.29 (27.4)
C _{trough} (microgram per mL)	0.10 (46.7)	NA	0.01 (28.5)

CV=Coefficient of Variation; NA=Not Applicable

- a. From Intensive PK analysis in a phase 2 trial in HIV-infected adults treated with FTC+TAF and EVG+COBI.
- b. From Population PK analysis in two trials of treatment-naïve adults with HIV-1 infection treated with FTC+TAF with EVG+COBI (N=539).
- c. From Population PK analysis in two trials of treatment-naïve adults with HIV-1 infection treated with FTC+TAF with EVG+COBI (N=841).

Specific Populations

Geriatric Patients

Pharmacokinetics of FTC and TAF have not been fully evaluated in the elderly (65 years of age and older). Population pharmacokinetics analysis of HIV-infected subjects in Phase 2 and Phase 3 trials of FTC+TAF and EVG+COBI showed that age did not have a clinically relevant effect on exposures of TAF up to 75 years of age [see *Use in Specific Populations (8.5)*].

Pediatric Patients

Treatment of HIV-1 Infection: Mean exposures of TAF in 24 pediatric subjects aged 12 to less than 18 years who received FTC+TAF with EVG+COBI were decreased (23% for AUC) and FTC exposures were similar compared to exposures achieved in treatment-naïve adults following administration of this dosage regimen. The TAF exposure differences are not thought to be clinically significant based on exposure-response relationships (Table 8).

Table 8 Multiple Dose PK Parameters of Emtricitabine, Tenofovir Alafenamide, and its Metabolite Tenofovir Following Oral Administration of FTC+TAF with EVG+COBI in HIV-Infected Pediatric Subjects Aged 12 to less than 18 Years^a

Parameter Mean (CV%)	Emtricitabine	Tenofovir Alafenamide	Tenofovir
C _{max} (microgram per mL)	2.3 (22.5)	0.17 (64.4)	0.02 (23.7)
AUC _{tau} (microgram•hour per mL)	14.4 (23.9)	0.20 ^b (50.0)	0.29 ^b (18.8)
C _{trough} (microgram per mL)	0.10 ^b (38.9)	NA	0.01 (21.4)

CV = Coefficient of Variation; NA = Not Applicable

a. From Intensive PK analysis in a trial in treatment-naïve pediatric subjects with HIV-1 infection (N=24).

b. N=23

Exposures of FTC and TAF achieved in 23 pediatric subjects between the ages of 6 to less than 12 years and weighing at least 25 kg (55 lbs) who received FTC+TAF with EVG+COBI were higher (20% to 80% for AUC) than exposures achieved in adults following the administration of this dosage regimen; however, the increase was not considered clinically significant (Table 9) [see *Use in Specific Populations* (8.4)].

Table 9 Multiple Dose PK Parameters of Emtricitabine, Tenofovir Alafenamide and its Metabolite Tenofovir Following Oral Administration of FTC+TAF with EVG+COBI in HIV-Infected Pediatric Subjects Aged 6 to less than 12 Years^a

Parameter Mean (CV%)	Emtricitabine	Tenofovir Alafenamide	Tenofovir
C _{max} (microgram per mL)	3.4 (27.0)	0.31 (61.2)	0.03 (20.8)
AUC _{tau} (microgram•hour per mL)	20.6 ^b (18.9)	0.33 (44.8)	0.44 (20.9)
C _{trough} (microgram per mL)	0.11 (24.1)	NA	0.02 (24.9)

CV = Coefficient of Variation; NA = Not Applicable

a. From Intensive PK analysis in a trial in virologically-suppressed pediatric subjects with HIV-1 infection (N=23).

b. N=22

HIV-1 PrEP: The pharmacokinetic data for FTC and TAF following administration of DESCovy in HIV-1 uninfected adolescents weighing 35 kg and above are not available. The dosage recommendations of DESCovy for HIV-1 PrEP in this population are based on known pharmacokinetic information in HIV-infected

adolescents taking FTC and TAF for treatment [see *Use in Specific Populations (8.4)*].

Race and Gender

Based on population pharmacokinetic analyses, there are no clinically meaningful differences based on race or gender.

Patients with Renal Impairment

The pharmacokinetics of FTC+TAF combined with EVG+COBI in HIV-1 infected subjects with renal impairment (eGFR 30 to 69 mL per minute by Cockcroft-Gault method), and in HIV-1 infected subjects with ESRD (eGFR less than 15 mL per minute by Cockcroft-Gault method) receiving chronic hemodialysis were evaluated in subsets of virologically-suppressed subjects in open-label trials. The pharmacokinetics of TAF were similar among healthy subjects, subjects with mild or moderate renal impairment, and subjects with ESRD receiving chronic hemodialysis; increases in FTC and TFV exposures in subjects with renal impairment were not considered clinically relevant (Table 10).

Table 10 Pharmacokinetics of the Components of DESCOVY and a Metabolite of TAF (Tenofovir) in HIV-Infected Adults with Renal Impairment Compared to Subjects with Normal Renal Function

Estimated Creatinine Clearance ^a	AUC _{tau} (microgram·hour per mL) Mean (CV%)			
	≥90 mL per minute (N=18) ^b	60–89 mL per minute (N=11) ^c	30–59 mL per minute (N=18) ^d	<15 mL per minute (N=12) ^e
Emtricitabine	11.4 (11.9)	17.6 (18.2)	23.0 (23.6)	62.9 (48.0) ^f
Tenofovir	0.32 (14.9)	0.46 (31.5)	0.61 (28.4)	8.72 (39.4) ^g

a. By Cockcroft-Gault method.

b. From a phase 2 trial in HIV-infected adults with normal renal function treated with FTC+TAF with EVG+COBI.

c. These subjects had an eGFR ranging from 60 to 69 mL per minute.

d. From a phase 3 trial in HIV-1 infected adults with renal impairment treated with FTC+TAF with EVG+COBI.

e. From a phase 3 trial in HIV-1 infected adults with ESRD receiving chronic hemodialysis treated with FTC+TAF with EVG+COBI; PK assessed prior to hemodialysis following 3 consecutive daily doses of FTC+TAF with EVG+COBI.

f. N = 11.

g. N = 10.

Patients with Hepatic Impairment

Emtricitabine: The pharmacokinetics of FTC has not been studied in subjects with hepatic impairment; however, FTC is not significantly metabolized by liver enzymes, so the impact of hepatic impairment should be limited.

Tenofovir Alafenamide: Clinically relevant changes in tenofovir pharmacokinetics in subjects with hepatic impairment were not observed in subjects with mild to moderate (Child-Pugh Class A and B) hepatic impairment [see *Use in Specific Populations (8.7)*].

Hepatitis B and/or Hepatitis C Virus Infection

The pharmacokinetics of FTC and TAF have not been fully evaluated in subjects infected with hepatitis B and/or C virus.

Drug Interaction Studies

The effects of coadministered drugs on the exposure of TAF are shown in Table 11 and the effects of DESCOVY or its components on the exposure of coadministered drugs are shown in Table 12 [these studies were conducted with DESCOVY or the components of DESCOVY (FTC or TAF) administered alone]. For information regarding clinical recommendations, see *Drug Interactions (7)*.

Table 11 Drug Interactions: Changes in TAF Pharmacokinetic Parameters in the Presence of Coadministered Drug(s)^a

Coadministered Drug	Coadministered Drug(s) Dosage (once daily) (mg)	Tenofovir Alafenamide Dosage (once daily) (mg)	N	Mean Ratio of TAF PK Parameters (90% CI); No effect = 1.00		
				C _{max}	AUC	C _{min}
Atazanavir	300 (+100 ritonavir)	10	10	1.77 (1.28, 2.44)	1.91 (1.55, 2.35)	NC
Cobicistat	150	8	12	2.83 (2.20, 3.65)	2.65 (2.29, 3.07)	NC
Darunavir	800 (+150 cobicistat)	25 ^b	11	0.93 (0.72, 1.21)	0.98 (0.80, 1.19)	NC
Darunavir	800 (+100 ritonavir)	10	10	1.42 (0.96, 2.09)	1.06 (0.84, 1.35)	NC
Dolutegravir	50	10	10	1.24 (0.88, 1.74)	1.19 (0.96, 1.48)	NC
Efavirenz	600	40 ^b	11	0.78 (0.58, 1.05)	0.86 (0.72, 1.02)	NC
Lopinavir	800 (+200 ritonavir)	10	10	2.19 (1.72, 2.79)	1.47 (1.17, 1.85)	NC
Rilpivirine	25	25	17	1.01 (0.84, 1.22)	1.01 (0.94, 1.09)	NC
Sertraline	50 (dosed as a single dose)	10 ^c	19	1.00 (0.86, 1.16)	0.96 (0.89, 1.03)	NC

NC=Not Calculated

- All interaction studies conducted in healthy volunteers.
- Study conducted with DESCOVY (FTC/TAF).
- Study conducted with FTC+TAF with EVG+COBI.

Table 12 Drug Interactions: Changes in PK Parameters for Coadministered Drug in the Presence of DESCOVY or the Individual Components^a

Coadministered Drug	Coadministered Drug Dosage (once daily) (mg)	Tenofovir Alafenamide Dosage (once daily) (mg)	N	Mean Ratio of Coadministered Drug PK Parameters (90% CI); No effect = 1.00		
				C _{max}	AUC	C _{min}
Atazanavir	300 +100 ritonavir	10	10	0.98 (0.89, 1.07)	0.99 (0.96, 1.01)	1.00 (0.96, 1.04)
Darunavir	800 +150 cobicistat	25 ^b	11	1.02 (0.96, 1.09)	0.99 (0.92, 1.07)	0.97 (0.82, 1.15)
Darunavir	800 +100 ritonavir	10	10	0.99 (0.91, 1.08)	1.01 (0.96, 1.06)	1.13 (0.95, 1.34)
Dolutegravir	50 mg	10	10	1.15 (1.04, 1.27)	1.02 (0.97, 1.08)	1.05 (0.97, 1.13)
Lopinavir	800 +200 ritonavir	10	10	1.00 (0.95, 1.06)	1.00 (0.92, 1.09)	0.98 (0.85, 1.12)
Midazolam ^c	2.5 (single dose, orally)	25	18	1.02 (0.92, 1.13)	1.13 (1.04, 1.23)	NC
	1 (single dose, intravenous)			0.99 (0.89, 1.11)	1.08 (1.04, 1.14)	NC
Rilpivirine	25	25	16	0.93 (0.87, 0.99)	1.01 (0.96, 1.06)	1.13 (1.04, 1.23)
Sertraline	50 (single dose)	10 ^d	19	1.14 (0.94, 1.38)	0.93 (0.77, 1.13)	NC

NC=Not Calculated

a. All interaction studies conducted in healthy volunteers.

b. Study conducted with DESCOVY (FTC/TAF).

c. A sensitive CYP3A4 substrate.

d. Study conducted with FTC+TAF with EVG+COBI.

12.4 Microbiology

Mechanism of Action

Emtricitabine: FTC, a synthetic nucleoside analog of cytidine, is phosphorylated by cellular enzymes to form emtricitabine 5'-triphosphate. Emtricitabine 5'-triphosphate inhibits the activity of the HIV-1 reverse transcriptase by competing with the natural substrate deoxycytidine 5'-triphosphate and by being incorporated into nascent viral DNA which results in chain termination. Emtricitabine 5'-triphosphate is a weak inhibitor of mammalian DNA polymerases α , β , ϵ , and mitochondrial DNA polymerase γ .

Tenofovir Alafenamide: TAF is a phosphonoamidate prodrug of tenofovir (2'-deoxyadenosine monophosphate analog). Plasma exposure to TAF allows for permeation into cells and then TAF is intracellularly converted to tenofovir through hydrolysis by cathepsin A. Tenofovir is subsequently phosphorylated by cellular kinases to the active metabolite tenofovir diphosphate. Tenofovir diphosphate inhibits HIV-1 replication through incorporation into viral DNA by the HIV reverse transcriptase, which results in DNA chain-termination.

Tenofovir has activity against HIV-1. Cell culture studies have shown that both tenofovir and FTC can be fully phosphorylated when combined in cells. Tenofovir diphosphate is a weak inhibitor of mammalian DNA polymerases that include mitochondrial DNA polymerase γ and there is no evidence of toxicity to mitochondria in cell culture.

Antiviral Activity in Cell Culture

Emtricitabine: The antiviral activity of FTC against laboratory and clinical isolates of HIV-1 was assessed in T lymphoblastoid cell lines, the MAGI-CCR5 cell line, and primary peripheral blood mononuclear cells. The EC₅₀ values for FTC were in the range of 1.3–640 nM. FTC displayed antiviral activity in cell culture against HIV-1 clades A, B, C, D, E, F, and G (EC₅₀ values ranged from 7-75 nM) and showed strain specific activity against HIV-2 (EC₅₀ values ranged from 7–1,500 nM).

In a study of FTC with a broad panel of representatives from the major classes of approved anti-HIV agents (NRTIs, non-nucleoside reverse transcriptase inhibitors [NNRTIs], integrase strand transfer inhibitors [INSTIs], and PIs) no antagonism was observed for these combinations.

Tenofovir Alafenamide: The antiviral activity of TAF against laboratory and clinical isolates of HIV-1 subtype B was assessed in lymphoblastoid cell lines, PBMCs, primary monocyte/macrophage cells and CD4⁺-T lymphocytes. The EC₅₀ values for TAF ranged from 2.0 to 14.7 nM.

TAF displayed antiviral activity in cell culture against all HIV-1 groups (M, N, O), including sub-types A, B, C, D, E, F, and G (EC₅₀ values ranged from 0.10 to 12.0 nM) and strain specific activity against HIV-2 (EC₅₀ values ranged from 0.91 to 2.63 nM).

In a study of TAF with a broad panel of representatives from the major classes of approved anti-HIV agents (NRTIs, NNRTIs, INSTIs, and PIs) no antagonism was observed for these combinations.

Prophylactic Activity in a Nonhuman Primate Model of HIV-1 Transmission

Emtricitabine and Tenofovir Alafenamide: The prophylactic activity of the combination of oral FTC and TAF was evaluated in a controlled study of macaques administered once weekly intra-rectal inoculations of chimeric simian/human immunodeficiency type 1 virus (SHIV) for up to 19 weeks (n=6). All 6 macaques that received FTC and TAF at doses resulting in PBMC exposures

consistent with those achieved in humans administered a dose of FTC/TAF 200/25 mg remained SHIV uninfected.

Resistance

In Cell Culture

Emtricitabine: HIV-1 isolates with reduced susceptibility to FTC were selected in cell culture and in subjects treated with FTC. Reduced susceptibility to FTC was associated with M184V or I substitutions in HIV-1 RT.

Tenofovir Alafenamide: HIV-1 isolates with reduced susceptibility to TAF were selected in cell culture. HIV-1 isolates selected by TAF expressed a K65R substitution in HIV-1 RT, sometimes in the presence of S68N or L429I substitutions; in addition, a K70E substitution in HIV-1 RT was observed.

In Clinical Trials

Treatment of HIV-1

The resistance profile of DESCovy in combination with other antiretroviral agents for the treatment of HIV-1 infection is based on studies of FTC+TAF with EVG+COBI in the treatment of HIV-1 infection. In a pooled analysis of antiretroviral-naïve subjects, genotyping was performed on plasma HIV-1 isolates from all subjects with HIV-1 RNA greater than 400 copies per mL at confirmed virologic failure, at Week 48, or at time of early study drug discontinuation. Genotypic resistance developed in 7 of 14 evaluable subjects. The resistance-associated substitutions that emerged were M184V/I (N=7) and K65R (N=1). Three subjects had virus with emergent R, H, or E at the polymorphic Q207 residue in reverse transcriptase.

One subject was identified with emergent resistance to FTC (M184M/I) out of 4 virologic failure subjects in a clinical study of virologically-suppressed subjects who switched from a regimen containing FTC+TDF to FTC+TAF with EVG+COBI (N=799).

HIV-1 PrEP

In the DISCOVER trial of HIV-1 uninfected men and transgender women who have sex with men and who are at risk of HIV-1 infection receiving DESCovy or TRUVADA for HIV-1 PrEP, genotyping was performed on participants found to be infected during the trial who had HIV-1 RNA \geq 400 copies/mL (6 of 7 participants receiving DESCovy and 13 of 15 participants receiving TRUVADA). The development of FTC resistance-associated substitutions, M184I and/or M184V, was observed in 4 HIV-1 infected participants in the TRUVADA group who had suspected baseline infections.

Cross-Resistance

Emtricitabine: FTC-resistant viruses with the M184V or I substitution were cross-resistant to lamivudine, but retained sensitivity to didanosine, stavudine, tenofovir, and zidovudine.

Viruses harboring substitutions conferring reduced susceptibility to stavudine and zidovudine-thymidine analog substitutions (M41L, D67N, K70R, L210W, T215Y/F, K219Q/E) or didanosine (L74V) remained sensitive to FTC. HIV-1 containing the K103N substitution or other substitutions associated with resistance to NNRTIs was susceptible to FTC.

Tenofovir Alafenamide: Tenofovir resistance substitutions K65R and K70E result in reduced susceptibility to abacavir, didanosine, emtricitabine, lamivudine, and tenofovir.

HIV-1 with multiple thymidine analog substitutions (M41L, D67N, K70R, L210W, T215F/Y, K219Q/E/N/R), or multinucleoside resistant HIV-1 with a T69S double insertion mutation or with a Q151M substitution complex including K65R, showed reduced susceptibility to TAF in cell culture.

13 NONCLINICAL TOXICOLOGY

13.1 Carcinogenesis, Mutagenesis, Impairment of Fertility

Emtricitabine

In long-term carcinogenicity studies of FTC, no drug-related increases in tumor incidence were found in mice at doses up to 750 mg per kg per day (23 times the human systemic exposure at the recommended dose of 200 mg per day in DESCOPY) or in rats at doses up to 600 mg per kg per day (28 times the human systemic exposure at the recommended dose in DESCOPY).

FTC was not genotoxic in the reverse mutation bacterial test (Ames test), mouse lymphoma or mouse micronucleus assays.

FTC did not affect fertility in male rats at approximately 140 times or in male and female mice at approximately 60 times higher exposures (AUC) than in humans given the recommended 200 mg daily dosage in DESCOPY. Fertility was normal in the offspring of mice exposed daily from before birth (in utero) through sexual maturity at daily exposures (AUC) of approximately 60 times higher than human exposures at the recommended 200 mg daily dosage in DESCOPY.

Tenofovir Alafenamide

Since TAF is rapidly converted to tenofovir and a lower tenofovir exposure in rats and mice was observed after TAF administration compared to TDF administration, carcinogenicity studies were conducted only with TDF. Long-term oral carcinogenicity studies of TDF in mice and rats were carried out at exposures up to approximately 10 times (mice) and 4 times (rats) those observed in humans at the recommended dose of TDF (300 mg) for HIV-1 infection. The tenofovir exposure in these studies was approximately 167 times (mice) and 55 times (rat) those observed in humans after administration of the daily recommended dose of DESCOPY. At the high dose in female mice, liver adenomas were increased at tenofovir exposures approximately 10 times (300

mg TDF) and 167 times (DESCOVY) the exposure observed in humans. In rats, the study was negative for carcinogenic findings.

TAF was not genotoxic in the reverse mutation bacterial test (Ames test), mouse lymphoma or rat micronucleus assays.

There were no effects on fertility, mating performance, or early embryonic development when TAF was administered to male rats at a dose equivalent to 62 times (25 mg TAF) the human dose based on body surface area comparisons for 28 days prior to mating and to female rats for 14 days prior to mating through Day 7 of gestation.

13.2 Animal Toxicology and/or Pharmacology

Minimal to slight infiltration of mononuclear cells in the posterior uvea was observed in dogs with similar severity after three- and nine-month administration of TAF; reversibility was seen after a three-month recovery period. No eye toxicity was observed in the dog at systemic exposures of 5 (TAF) and 15 (tenofovir) times the exposure seen in humans with the recommended daily TAF dose in DESCOVY.

14 CLINICAL STUDIES

14.1 Overview of Clinical Trials

The efficacy and safety of DESCOVY have been evaluated in the trials summarized in Table 13.

Table 13 Trials Conducted with FTC+TAF-Containing Products for HIV-1 Treatment and DESCOVY for HIV-1 PrEP

Trial	Population	Study Arms (N)	Timepoint
Study 104 ^a (NCT01780506) Study 111 ^a (NCT01797445)	HIV-1 infected treatment-naïve adults	FTC+TAF with EVG+COBI ^b (866) FTC+TDF with EVG+COBI ^c (867)	48 Weeks
Study 109 ^d (NCT01815736)	HIV-1 infected virologically-suppressed ^f adults	FTC+TAF with EVG+COBI ^b (799) ATRIPLA [®] or TRUVADA [®] +atazanavir+cobicistat or ritonavir or FTC+TDF with EVG+COBI ^c (397)	48 Weeks
Study 112 ^e (NCT01818596)	HIV-1 infected virologically-suppressed ^f adults with renal impairment ^g	FTC+TAF with EVG+COBI ^b (242)	24 Weeks
Study 1825 ^e (NCT02600819)	HIV-1 infected virologically-suppressed ^f adults with ESRD ^h receiving chronic hemodialysis	FTC+TAF with EVG+COBI ^b (55)	48 Weeks
Study 106 ^e (Cohort 1) (NCT01854775)	HIV-1 infected treatment-naïve adolescents between the ages of 12 to less than 18 years (at least 35 kg)	FTC+TAF with EVG+COBI ^b (50)	48 Weeks
Study 106 ^e (Cohort 2) (NCT01854775)	HIV-1 infected, virologically suppressed children between the ages of 6 to less than 12 years (at least 25 kg)	FTC+TAF with EVG+COBI ^b (23)	24 Weeks
DISCOVER ^a (NCT02842086)	HIV-1 uninfected men or transgender women who have sex with men	DESCOVY (2,670) TRUVADA [®] (2,665)	4,370 person-years

a. Randomized, double-blind, active-controlled study.

b. Administered as GENVOYA[®].

c. Administered as STRIBILD[®].

d. Randomized, open-label, active controlled trial.

e. Open label trial

f. HIV-1 RNA less than 50 copies per mL.

g. Estimated creatinine clearance between 30 and 69 mL per minute by Cockcroft-Gault method.

h. End stage renal disease (estimated creatinine clearance of less than 15 mL per minute by Cockcroft-Gault method).

i. Exposure in the DESCOVY group.

14.2 Clinical Trial Results for Treatment of HIV-1

In trials of FTC+TAF with EVG+COBI in HIV-1 infected adults as initial therapy in those with no antiretroviral treatment history (N=866) and to replace a stable antiretroviral regimen in those who were virologically-suppressed for at least 6 months with no known resistance substitutions (N=799), 92% and 96% of patients in the two populations, respectively, had HIV-1 RNA less than 50 copies per mL at Week 48.

An open-label, single arm trial of FTC+TAF with EVG+COBI enrolled 50 treatment-naïve HIV-1 infected adolescents aged 12 to less than 18 years weighing at least 35 kg (cohort 1) and 23 virologically suppressed children aged 6 to less than 12 years weighing at least 25 kg (cohort 2). In cohort 1, the virologic response rate (i.e., HIV-1 RNA less than 50 copies per mL) was 92% (46/50) and the mean increase from baseline in CD4+ cell count was 224 cells per mm³ at Week 48. In cohort 2, 100% of subjects remained virologically suppressed at Week 24. From a mean (SD) baseline CD4+ cell count of 966 (201.7), the mean change from baseline in CD4+ cell count was -150 cells/mm³ and the mean (SD) change in CD4% was -1.5% (3.7%) at Week 24. All subjects maintained CD4+ cell counts above 400 cells/mm³ [see *Adverse Reactions (6.1) and Use in Specific Populations (8.4)*].

In a trial in 248 HIV-1 infected adults with estimated creatinine clearance greater than 30 mL per minute but less than 70 mL per minute, 95% (235/248) of the combined population of treatment-naïve subjects began on FTC+TAF with EVG+COBI (N=6) and those previously virologically-suppressed on other regimens and switched to FTC+TAF with EVG+COBI (N=242) had HIV-1 RNA less than 50 copies per mL at Week 24.

In a trial in 55 HIV-1 infected virologically-suppressed adults with ESRD (estimated creatinine clearance of less than 15 mL per minute) receiving chronic hemodialysis for at least 6 months who switched to FTC+TAF with EVG+COBI, 82% (45/55) maintained HIV-1 RNA less than 50 copies per mL at Week 48. Two subjects had HIV-1 RNA \geq 50 copies per mL by Week 48, 7 discontinued due to AE or other reasons while suppressed, and 1 did not have an HIV-1 RNA measurement at Week 48.

14.3 Clinical Trial Results for HIV-1 PrEP

The efficacy and safety of DESCOVY to reduce the risk of acquiring HIV-1 infection were evaluated in a randomized, double-blind multinational trial (DISCOVER) in HIV-seronegative men (N=5,262) or transgender women (N=73) who have sex with men and are at risk of HIV-1 infection, comparing once daily DESCOVY (N=2,670) to TRUVADA (FTC/TDF 200 mg/300 mg; N=2,665). Evidence of risk behavior at entry into the trial included at least one of the following: two or more unique condomless anal sex partners in the past 12 weeks or a diagnosis of rectal gonorrhea/chlamydia or syphilis in the past 24 weeks. The median age of participants was 34 years (range, 18-76); 84% were White, 9% Black/Mixed Black, 4% Asian, and 24% Hispanic/Latino. At baseline, 897 participants (17%) reported receiving TRUVADA for PrEP.

At weeks 4, 12, and every 12 weeks thereafter, all participants received local standard of care HIV-1 prevention services, including HIV-1 testing, evaluation of adherence, safety evaluations, risk-reduction counseling, condoms, management of sexually transmitted infections, and assessment of sexual behavior.

Trial participants maintained a high risk of sexual HIV-1 acquisition, with high rates of rectal gonorrhea (DESCOVY, 24%; TRUVADA, 25%), rectal chlamydia

(DESCOVY, 30%; TRUVADA, 31%), and syphilis (14% in both treatment groups) during the trial.

The primary outcome was the incidence of documented HIV-1 infection per 100 person-years in participants randomized to DESCOVY and TRUVADA (with a minimum follow-up of 48 weeks and at least 50% of participants having 96 weeks of follow-up). DESCOVY was non-inferior to TRUVADA in reducing the risk of acquiring HIV-1 infection (Table 14). The results were similar across the subgroups of age, race, gender identity, and baseline TRUVADA for PrEP use.

Table 14 HIV-1 Infection Results in DISCOVER Trial – Full Analysis Set

	DESCOVY (N=2,670)	TRUVADA (N=2,665)	Rate Ratio (95% CI)
	4,370 person-years	4,386 person-years	
HIV-1 infections, n	7	15	
Rate of HIV-1 infections per 100 person-years	0.16	0.34	0.468 (0.19, 1.15)

CI = Confidence interval.

Of the 22 participants diagnosed with HIV-1 infection in the trial, five had suspected baseline infection prior to study entry (DESCOVY, 1; TRUVADA, 4). In a case-control substudy of intracellular drug levels and estimated number of daily doses as measured by dried blood spot testing, median intracellular tenofovir diphosphate concentrations were substantially lower in participants infected with HIV-1 at the time of diagnosis compared with uninfected matched control participants. For both DESCOVY and TRUVADA, efficacy was therefore strongly correlated to adherence to daily dosing.

16 HOW SUPPLIED/STORAGE AND HANDLING

DESCOVY 200 mg/25 mg tablets are blue, rectangular-shaped, and film-coated with “GSI” debossed on one side and “225” on the other side. Each bottle contains 30 tablets (NDC 61958-2002-1), a silica gel desiccant, polyester coil, and is closed with a child-resistant closure.

Store at 25°C (77°F); excursions permitted to 15°C to 30°C (59°F to 86°F) (see USP Controlled Room Temperature).

- Keep container tightly closed.
- Dispense only in original container.

17 PATIENT COUNSELING INFORMATION

Advise the patient to read the FDA-approved patient labeling (Medication Guide).

Important Information for Uninfected Individuals Taking DESCOVY for HIV-1 PrEP

Advise HIV-1 uninfected individuals about the following [*see Warnings and Precautions (5.2)*]:

- The need to confirm that they are HIV-negative before starting to take DESCOVY to reduce the risk of acquiring HIV-1.
- That HIV-1 resistance substitutions may emerge in individuals with undetected HIV-1 infection who are taking DESCOVY, because DESCOVY alone does not constitute a complete regimen for HIV-1 treatment.
- The importance of taking DESCOVY on a regular dosing schedule and strict adherence to the recommended dosing schedule to reduce the risk of acquiring HIV-1. Uninfected individuals who miss doses are at greater risk of acquiring HIV-1 than those who do not miss doses.
- That DESCOVY does not prevent other sexually acquired infections and should be used as part of a complete prevention strategy including other prevention measures.
- To use condoms consistently and correctly to lower the chances of sexual contact with any body fluids such as semen, vaginal secretions, or blood.
- The importance of knowing their HIV-1 status and the HIV-1 status of their partner(s).
- The importance of virologic suppression in their partner(s) with HIV-1.
- The need to get tested regularly for HIV-1 (at least every 3 months, or more frequently for some individuals such as adolescents) and to ask their partner(s) to get tested as well.
- To report any symptoms of acute HIV-1 infection (flu-like symptoms) to their healthcare provider immediately.
- That the signs and symptoms of acute infection include fever, headache, fatigue, arthralgia, vomiting, myalgia, diarrhea, pharyngitis, rash, night sweats, and adenopathy (cervical and inguinal).
- To get tested for other sexually transmitted infections, such as syphilis, chlamydia, and gonorrhea, that may facilitate HIV-1 transmission.
- To assess their sexual risk behavior and get support to help reduce sexual risk behavior.

Post-treatment Acute Exacerbation of Hepatitis B in Patients with HBV Infection

Inform individuals that severe acute exacerbations of hepatitis B have been reported in patients who are infected with HBV and have discontinued products containing FTC and/or TDF and may likewise occur with discontinuation of DESCOVY [*see Warnings and Precautions (5.1)*]. Advise HBV-infected individuals to not discontinue DESCOVY without first informing their healthcare provider.

Immune Reconstitution Syndrome

Advise HIV-1 infected patients to inform their healthcare provider immediately of any symptoms of infection. In some patients with advanced HIV infection (AIDS), signs and symptoms of inflammation from previous infections may occur soon after anti-HIV treatment is started [see *Warnings and Precautions (5.3)*].

New Onset or Worsening Renal Impairment

Advise HIV-1 infected patients and uninfected individuals to avoid taking DESCOVY with concurrent or recent use of nephrotoxic agents. Renal impairment, including cases of acute renal failure, has been reported in association with the use of tenofovir prodrugs [see *Warnings and Precautions (5.4)*].

Lactic Acidosis and Severe Hepatomegaly

Lactic acidosis and severe hepatomegaly with steatosis, including fatal cases, have been reported with use of drugs similar to DESCOVY. Advise HIV-1 infected patients and uninfected individuals that they should stop DESCOVY if they develop clinical symptoms suggestive of lactic acidosis or pronounced hepatotoxicity [see *Warnings and Precautions (5.5)*].

Dosage Recommendations for Treatment of HIV-1 Infection

Inform HIV-1 infected patients that it is important to take DESCOVY with other antiretroviral drugs for the treatment of HIV-1 on a regular dosing schedule with or without food and to avoid missing doses as it can result in development of resistance [see *Dosage and Administration (2.3)*].

Pregnancy Registry

Inform individuals using DESCOVY that there is an antiretroviral pregnancy registry to monitor fetal outcomes of pregnant women exposed to DESCOVY [see *Use in Specific Populations (8.1)*].

Lactation

Instruct mothers with HIV-1 infection not to breastfeed because of the risk of passing the HIV-1 virus to the baby [see *Use in Specific Populations (8.2)*].

DESCOVY and TRUVADA are trademarks of Gilead Sciences, Inc., or its related companies. All other trademarks referenced herein are the property of their respective owners.

© 2019 Gilead Sciences, Inc. All rights reserved.

Medication Guide
DESCOVY® (des-KOH-vee)
(emtricitabine and tenofovir alafenamide)
tablets

Read this Medication Guide before you start taking DESCOVY and each time you get a refill. There may be new information. This information does not take the place of talking to your healthcare provider about your medical condition or your treatment.

This Medication Guide provides information about two different ways that DESCOVY may be used. See the section “**What is DESCOVY?**” for detailed information about how DESCOVY may be used.

What is the most important information I should know about DESCOVY?

DESCOVY can cause serious side effects, including:

- **Worsening of hepatitis B virus infection (HBV). Your healthcare provider will test you for HBV infection before or when you start treatment with DESCOVY. If you have HBV infection and take DESCOVY, your HBV may get worse (flare-up) if you stop taking DESCOVY. A “flare-up” is when your HBV infection suddenly returns in a worse way than before.**
 - Do not run out of DESCOVY. Refill your prescription or talk to your healthcare provider before your DESCOVY is all gone.
 - Do not stop taking DESCOVY without first talking to your healthcare provider.
 - If you stop taking DESCOVY, your healthcare provider will need to check your health often and do blood tests regularly for several months to check your HBV infection, or give you a medicine to treat hepatitis B. Tell your healthcare provider about any new or unusual symptoms you may have after you stop taking DESCOVY.

For more information about side effects, see the section “What are the possible side effects of DESCOVY?”

Other important information for people who take DESCOVY to help reduce their risk of getting human immunodeficiency virus-1 (HIV-1) infection, also called pre-exposure prophylaxis or “PrEP”:

Before taking DESCOVY to reduce your risk of getting HIV-1:

- **You must be HIV-1 negative to start DESCOVY. You must get tested to make sure that you do not already have HIV-1 infection.**
- **Do not take DESCOVY for HIV-1 PrEP unless you are confirmed to be HIV-1 negative.**
- Some HIV-1 tests can miss HIV-1 infection in a person who has recently become infected. If you have flu-like symptoms, you could have recently become infected with HIV-1. Tell your healthcare provider if you had a flu-like illness within the last month before starting DESCOVY or at any time while taking DESCOVY. Symptoms of new HIV-1 infection include:
 - tiredness
 - fever
 - joint or muscle aches
 - headache
 - sore throat
 - vomiting or diarrhea
 - rash
 - night sweats
 - enlarged lymph nodes in the neck or groin

While you are taking DESCOVY for HIV-1 PrEP:

- **DESCOVY does not prevent other sexually transmitted infections (STIs). Practice safer sex by using a latex or polyurethane condom to reduce the risk of getting STIs.**
- **You must stay HIV-1 negative to keep taking DESCOVY for HIV-1 PrEP.**
 - Know your HIV-1 status and the HIV-1 status of your partners.
 - Ask your partners with HIV-1 if they are taking HIV-1 medicines and have an undetectable viral load. An undetectable viral load is when the amount of virus in the blood is too low to be measured in a lab test. To maintain an undetectable viral load, your partners must keep taking HIV-1 medicines every day. Your risk of getting HIV-1 is lower if your partners with HIV-1 are taking effective treatment.
 - Get tested for HIV-1 at least every 3 months or when your healthcare provider tells you.
 - Get tested for other STIs such as syphilis, chlamydia, and gonorrhea. These infections make it easier for HIV-1 to infect you.

- If you think you were exposed to HIV-1, tell your healthcare provider right away. They may want to do more tests to be sure you are still HIV-1 negative.
- Get information and support to help reduce sexual risk behaviors.
- Do not miss any doses of DESCOVY. Missing doses increases your risk of getting HIV-1 infection.
- If you do become HIV-1 positive, you need more medicine than DESCOVY alone to treat HIV-1. DESCOVY by itself is not a complete treatment for HIV-1.

If you have HIV-1 and take only DESCOVY, over time your HIV-1 may become harder to treat.

What is DESCOVY?

DESCOVY is a prescription medicine that may be used in two different ways. DESCOVY is used:

- to treat HIV-1 infection
 - in adults and children who weigh at least 77 pounds (35 kg) together with other HIV-1 medicines
 - in children who weigh at least 55 pounds (25 kg) and less than 77 pounds (35 kg) together with certain other HIV-1 medicines. Your healthcare provider will determine which other HIV-1 medicines may be used with DESCOVY.
- for HIV-1 PrEP to reduce the risk of getting HIV-1 infection in adults and adolescents who weigh at least 77 pounds (35 kg). It is not known if DESCOVY is effective in reducing the risk of getting HIV-1 from certain types of sex.
 - DESCOVY for PrEP is not for use in people born female (assigned female at birth) who are at risk of getting HIV-1 infection from vaginal sex, because its effectiveness has not been studied.

HIV-1 is the virus that causes Acquired Immune Deficiency Syndrome (AIDS).

DESCOVY contains the prescription medicines emtricitabine and tenofovir alafenamide.

It is not known if DESCOVY for treatment of HIV-1 infection is safe and effective in children who weigh less than 55 pounds (25 kg).

It is not known if DESCOVY is safe and effective in reducing the risk of HIV-1 infection in people who weigh less than 77 pounds (35 kg).

For people taking DESCOVY for HIV-1 PrEP:

Do not take DESCOVY for HIV-1 PrEP if:

- **you already have HIV-1 infection.** If you are HIV-1 positive, you need to take other medicines with DESCOVY to treat HIV-1. DESCOVY by itself is not a complete treatment for HIV-1.
- **you do not know your HIV-1 infection status.** You may already be HIV-1 positive. You need to take other HIV-1 medicines with DESCOVY to treat HIV-1 infection.

DESCOVY can only help reduce your risk of getting HIV-1 infection **before** you are infected.

What should I tell my healthcare provider before taking DESCOVY?

Before taking DESCOVY, tell your healthcare provider about all of your medical conditions, including if you:

- have liver problems, including HBV infection
- have kidney problems
- are pregnant or plan to become pregnant. It is not known if DESCOVY can harm your unborn baby. Tell your healthcare provider if you become pregnant during treatment with DESCOVY.

Pregnancy Registry: There is a pregnancy registry for people who take DESCOVY during pregnancy. The purpose of this registry is to collect information about the health of you and your baby. Talk with your healthcare provider about how you can take part in this registry.

- are breastfeeding or plan to breastfeed.
 - Do not breastfeed if you take DESCOVY for treatment of HIV-1 because of the risk of passing HIV-1 to your baby.
 - One of the ingredients in DESCOVY (emtricitabine) passes into your breast milk.

Tell your healthcare provider about all the medicines you take, including prescription and over-the-counter medicines, vitamins, and herbal supplements.

Some medicines may interact with DESCOVY. Keep a list of your medicines and show it to your healthcare provider and pharmacist when you get a new medicine.

- You can ask your healthcare provider or pharmacist for a list of medicines that interact with DESCOVY.
- **Do not start a new medicine without telling your healthcare provider.** Your healthcare provider can tell you if it is safe to take DESCOVY with other medicines.

How should I take DESCOVY?

- Take DESCOVY exactly as your healthcare provider tells you to take it. If you take DESCOVY to treat HIV-1 infection, you need to take DESCOVY with other HIV-1 medicines. Your healthcare provider will tell you what medicines to take and how to take them.
- Take DESCOVY 1 time each day with or without food.
- If you are on dialysis, take your daily dose of DESCOVY following dialysis.
- Do not change your dose or stop taking DESCOVY without first talking with your healthcare provider. Stay under a healthcare provider's care when taking DESCOVY. Do not miss a dose of DESCOVY.
- If you take too much DESCOVY, call your healthcare provider or go to the nearest hospital emergency room right away.
- When your DESCOVY supply starts to run low, get more from your healthcare provider or pharmacy.
 - If you are taking DESCOVY for treatment of HIV-1, the amount of virus in your blood may increase if the medicine is stopped for even a short time. The virus may develop resistance to DESCOVY and become harder to treat.
 - If you are taking DESCOVY for HIV-1 PrEP, missing doses increases your risk of getting HIV-1 infection.

What are the possible side effects of DESCOVY?

DESCOVY may cause serious side effects, including:

- **See "What is the most important information I should know about DESCOVY?"**
- **Changes in your immune system (Immune Reconstitution Syndrome)** can happen when you start taking medicines to treat HIV-1 infection. Your immune system may get stronger and begin to fight infections that have been hidden in your body for a long time. Tell your healthcare provider right away if you start having any new symptoms after starting your HIV-1 medicine.
- **New or worse kidney problems, including kidney failure.** Your healthcare provider should do blood and urine tests to check your kidneys before you start and while taking DESCOVY. Your healthcare provider may tell you to stop taking DESCOVY if you develop new or worse kidney problems.
- **Too much lactic acid in your blood (lactic acidosis).** Too much lactic acid is a serious but rare medical emergency that can lead to death. Tell your healthcare provider right away if you get these symptoms: weakness or being more tired than usual, unusual muscle pain, being short of breath or fast breathing, stomach pain with nausea and vomiting, cold or blue hands and feet, feel dizzy or lightheaded, or a fast or abnormal heartbeat.
- **Severe liver problems.** In rare cases, severe liver problems can happen that can lead to death. Tell your healthcare provider right away if you get these symptoms: skin or the white part of your eyes turns yellow, dark "tea-colored" urine, light-colored stools, loss of appetite for several days or longer, nausea, or stomach-area pain.

The most common side effect of DESCOVY for treatment of HIV-1 is nausea.

The most common side effect of DESCOVY for HIV-1 PrEP is diarrhea.

These are not all of the possible side effects of DESCOVY.

Call your doctor for medical advice about side effects. You may report side effects to FDA at 1-800-FDA-1088.

How should I store DESCOVY?

- Store DESCOVY between 68°F to 77°F (20°C to 25°C).
- Keep DESCOVY in its original container.
- Keep the container tightly closed.

Keep DESCOVY and all medicines out of reach of children.

General information about the safe and effective use of DESCOVY.

Medicines are sometimes prescribed for purposes other than those listed in a Medication Guide. Do not use DESCOVY for a condition for which it was not prescribed. Do not give DESCOVY to other people, even if they have the same symptoms you have. It may harm them. You can ask your healthcare provider or pharmacist for information about DESCOVY that is written for health professionals.

What are the ingredients in DESCOVY?

Active ingredients: emtricitabine and tenofovir alafenamide.

Inactive ingredients: croscarmellose sodium, magnesium stearate, and microcrystalline cellulose.

The tablets are film-coated with a coating material containing indigo carmine aluminum lake, polyethylene glycol, polyvinyl alcohol, talc, and titanium dioxide.

Manufactured and distributed by: Gilead Sciences, Inc. Foster City, CA 94404

DESCOVY is a trademark of Gilead Sciences, Inc., or its related companies. All other trademarks referenced herein are the property of their respective owners.

© 2019 Gilead Sciences, Inc. All rights reserved.

208215-GS-005

For more information, call 1-800-445-3235 or go to www.DESCOVY.com.

This Medication Guide has been approved by the U.S. Food and Drug Administration.

Revised: 12/2019

PRODUCT MONOGRAPH

^{Pr}ELIQUIS®

apixaban tablets

2.5 mg and 5 mg

Anticoagulant

Pfizer Canada ULC
17,300 Trans-Canada Highway
Kirkland, Quebec H9J 2M5

Date of Initial Approval:

13 December 2011

Date of Revision:

07 October 2019

Bristol-Myers Squibb Canada Co.
Montreal, Canada H4S 0A4
www.bmscanada.ca

Registered trademark of Bristol-Myers Squibb Company used under license by Bristol-Myers Squibb Canada Co.

Submission Control No: 229267

Table of Contents

PART I: HEALTH PROFESSIONAL INFORMATION	3
SUMMARY PRODUCT INFORMATION.....	3
INDICATIONS AND CLINICAL USE	3
CONTRAINDICATIONS.....	4
WARNINGS AND PRECAUTIONS	4
ADVERSE REACTIONS.....	10
DOSAGE AND ADMINISTRATION	26
OVERDOSAGE.....	33
ACTION AND CLINICAL PHARMACOLOGY	34
SPECIAL HANDLING INSTRUCTIONS.....	39
DOSAGE FORMS, COMPOSITION AND PACKAGING.....	39
PART II: SCIENTIFIC INFORMATION	41
PHARMACEUTICAL INFORMATION.....	41
CLINICAL TRIALS	42
DETAILED PHARMACOLOGY	75
TOXICOLOGY.....	76
REFERENCES.....	77
PART III: CONSUMER INFORMATION	79

PrELIQUIS®

Apixaban tablets

PART I: HEALTH PROFESSIONAL INFORMATION

SUMMARY PRODUCT INFORMATION

Route of Administration	Dosage Form / Strength	Nonmedicinal Ingredients
Oral	Tablet, 2.5 mg and 5 mg	Anhydrous lactose, croscarmellose sodium, hypromellose, lactose monohydrate, magnesium stearate, microcrystalline cellulose, sodium lauryl sulphate, titanium dioxide, triacetin, red iron oxide (5 mg tablets) and yellow iron oxide (2.5 mg tablets).

INDICATIONS AND CLINICAL USE

ELIQUIS (apixaban) is indicated for:

- the prevention of venous thromboembolic events (VTE) in adult patients who have undergone elective knee or hip replacement surgery.
- the prevention of stroke and systemic embolism in patients with atrial fibrillation.
- the treatment of venous thromboembolic events (deep vein thrombosis [DVT], pulmonary embolism [PE]) and prevention of recurrent DVT and PE.

Geriatrics (≥ 65 years of age)

Clinical studies in VTE prevention, stroke prevention in patients with atrial fibrillation (SPAF), treatment of DVT and PE, and prevention of recurrent DVT and PE included patients ≥ 65 years of age (see WARNINGS AND PRECAUTIONS, Renal Impairment, DOSAGE AND ADMINISTRATION, and CLINICAL TRIALS).

Pediatrics (< 18 years of age)

The safety and efficacy of ELIQUIS in pediatric patients have not been established; therefore, Health Canada has not authorized an indication for pediatric use. Pharmacokinetic / pharmacodynamic data are available from a single-dose pediatric study (28 days to <18 years) (see ACTION AND CLINICAL PHARMACOLOGY, Special Populations and Conditions).

CONTRAINDICATIONS

- Clinically significant active bleeding, including gastrointestinal bleeding
- Lesions or conditions at increased risk of clinically significant bleeding, e.g., recent cerebral infarction (ischemic or hemorrhagic), active peptic ulcer disease with recent bleeding, patients with spontaneous or acquired impairment of hemostasis
- Hepatic disease associated with coagulopathy and clinically relevant bleeding risk (see ACTION AND CLINICAL PHARMACOLOGY, Hepatic Impairment)
- Concomitant systemic treatment with strong inhibitors of **both** CYP 3A4 and P-glycoprotein (P-gp) such as azole-antimycotics, e.g., ketoconazole, itraconazole, voriconazole, or posaconazole, and HIV protease inhibitors, e.g., ritonavir (see WARNINGS AND PRECAUTIONS, Drug Interactions, and DRUG INTERACTIONS, Inhibitors of both CYP 3A4 and P-gp)
- Concomitant treatment with any other anticoagulant, including
 - unfractionated heparin (UFH), except at doses used to maintain a patent central venous or arterial catheter,
 - low molecular weight heparins (LMWH), such as enoxaparin and dalteparin,
 - heparin derivatives, such as fondaparinux, and
 - oral anticoagulants, such as warfarin, dabigatran, rivaroxaban, except under circumstances of switching therapy to or from apixaban.
- Hypersensitivity to ELIQUIS (apixaban) or to any ingredients of the formulation. For a complete listing of ingredients see DOSAGE FORMS, COMPOSITION AND PACKAGING.

WARNINGS AND PRECAUTIONS

PREMATURE DISCONTINUATION OF ANY ORAL ANTICOAGULANT, INCLUDING ELIQUIS, INCREASES THE RISK OF THROMBOTIC EVENTS.

To reduce this risk, consider coverage with another anticoagulant if ELIQUIS is discontinued for a reason other than pathological bleeding or completion of a course of therapy.

The following Warnings and Precautions are listed in alphabetical order.

Bleeding

The possibility of a hemorrhage should be considered in evaluating the condition of any anticoagulated patient. As with all anticoagulants, ELIQUIS (apixaban) should be used with caution in circumstances associated with an increased risk of bleeding. Bleeding can occur at any site during therapy with ELIQUIS. An unexplained fall in hemoglobin, hematocrit or blood pressure should lead to a search for a bleeding site. Patients should be advised of signs and symptoms of blood loss and to report them immediately or go to an emergency room.

Patients at high risk of bleeding should not be prescribed ELIQUIS (see CONTRAINDICATIONS).

Should severe bleeding occur, treatment with ELIQUIS must be discontinued and the source of bleeding investigated promptly.

Close clinical surveillance (i.e., looking for signs of bleeding or anemia) is recommended throughout the treatment period. This may include looking for obvious signs of bleeding, e.g. hematomas, epistaxis, or hypotension, testing for occult blood in the stool, checking serum hemoglobin for significant decrease, etc., especially if other factors/conditions that generally increase the risk of hemorrhage are also present. (see Table 1 below).

Table 1 – Factors Which Increase Hemorrhagic Risk

Factors increasing apixaban plasma levels	Severe renal impairment (eCrCl < 30 mL/min)
	Concomitant systemic treatment with strong inhibitors of both CYP 3A4 and P-gp
Pharmacodynamic interactions	NSAID
	Platelet aggregation inhibitors, including ASA, clopidogrel, prasugrel, ticagrelor
	Selective serotonin reuptake inhibitors (SSRI), and serotonin norepinephrine reuptake inhibitors (SNRIs)
Diseases / procedures with special hemorrhagic risks	Congenital or acquired coagulation disorders
	Thrombocytopenia or functional platelet defects
	Uncontrolled severe arterial hypertension
	Active ulcerative gastrointestinal disease
	Recent gastrointestinal bleeding
	Recent intracranial hemorrhage
	Intraspinal or intracerebral vascular abnormalities
	Recent brain, spinal or ophthalmological surgery
Bronchiectasis or history of pulmonary bleeding	
Others	Age > 75 years

Concomitant use of ELIQUIS with drugs affecting hemostasis increases the risk of bleeding. Care should be taken if patients are treated concomitantly with drugs affecting hemostasis such as non-steroidal anti-inflammatory drugs (NSAID), acetylsalicylic acid (ASA), platelet aggregation inhibitors, selective serotonin reuptake inhibitors (SSRI), or serotonin norepinephrine reuptake inhibitors (SNRIs) (see also DRUG INTERACTIONS).

Concomitant use of ASA or dual antiplatelet therapy with either ELIQUIS or warfarin increases the risk of major bleeding in patients with atrial fibrillation. Other platelet aggregation inhibitors such as prasugrel and ticagrelor, have not been studied with ELIQUIS in any patient population, and are **not** recommended as concomitant therapy (see DRUG INTERACTIONS).

In patients with atrial fibrillation and having a condition that warrants single or dual antiplatelet therapy, a careful assessment of the potential benefits against the potential risks should be made before combining this therapy with ELIQUIS.

In high-risk patients following acute coronary thrombosis, apixaban 5 mg bid, as an adjunct to standard anti-platelet treatment, has led to significantly increased bleeding (see ACTION AND CLINICAL PHARMACOLOGY, Post-acute coronary syndrome patients).

The use of thrombolytics should generally be avoided during acute myocardial infarction (AMI) or acute stroke in patients treated with apixaban, due to expected increased risk of major bleeding.

Cardiovascular

Patients with Valvular Disease

Safety and efficacy of ELIQUIS have not been studied in patients with prosthetic heart valves or those with hemodynamically significant rheumatic heart disease, especially mitral stenosis. There are no data to support that ELIQUIS 5 mg twice daily or 2.5 mg twice daily provides adequate anticoagulation in patients with prosthetic heart valves, with or without atrial fibrillation. Therefore, the use of ELIQUIS is not recommended in this setting.

Of note, in the pivotal ARISTOTLE trial, that evaluated ELIQUIS in the prevention of stroke in atrial fibrillation when compared to warfarin, 18% of patients had other valvular disease, including aortic stenosis, aortic regurgitation, and/or mitral regurgitation. In the AVERROES trial, that also evaluated ELIQUIS in patients with atrial fibrillation but when compared to ASA, 23% had other valvular disease of a similar nature to that described just above in the ARISTOTLE trial.

Drug Interactions

Inhibitors of Both CYP 3A4 and P-glycoprotein (P-gp)

Co-administration of apixaban with ketoconazole (400 mg q.d.), a strong inhibitor of CYP 3A4 and P-gp, led to a 2-fold increase in mean apixaban AUC and a 1.6-fold increase in apixaban C_{max}. Therefore, the use of ELIQUIS is contraindicated in patients receiving concomitant systemic treatment with strong inhibitors of **both** CYP 3A4 and P-gp, such as azole-antimycotics (e.g., ketoconazole, itraconazole, voriconazole and posaconazole), and HIV protease inhibitors (e.g., ritonavir) (see CONTRAINDICATIONS). These drug products may increase apixaban exposure by two-fold (see DRUG INTERACTIONS, Inhibitors of Both CYP 3A4 and P-gp).

Inducers of Both CYP 3A4 and P-gp

The concomitant use of ELIQUIS with strong inducers of CYP 3A4 and P-gp (e.g., rifampin, phenytoin, carbamazepine, phenobarbital or St. John's Wort) reduces apixaban exposure. Combined use of ELIQUIS with strong inducers of both CYP 3A4 and P-gp should generally be avoided since efficacy of ELIQUIS may be compromised (see DRUG INTERACTIONS, Inducers of Both CYP 3A4 and P-gp). Paradoxically, increased bleeding has been noted in patients with atrial fibrillation taking concomitant inducers with either apixaban or warfarin (see DRUG INTERACTIONS, Inducers of Both CYP 3A4 and P-gp, Table 10).

Hepatic/Biliary/Pancreatic

Hepatic Impairment

ELIQUIS is contraindicated in patients with hepatic disease associated with coagulopathy and clinically relevant bleeding risk (see CONTRAINDICATIONS). ELIQUIS is not recommended in patients with severe hepatic impairment (see ACTION AND CLINICAL PHARMACOLOGY, Hepatic Impairment). ELIQUIS should be used with caution in patients with mild or moderate hepatic impairment (Child Pugh A or B) (see DOSAGE AND ADMINISTRATION, Hepatic Impairment).

Patients with elevated liver enzymes (ALT/AST > 2 x ULN, or total bilirubin \geq 1.5 x ULN) were excluded in clinical trials. Therefore, ELIQUIS should be used with caution in these patients.

Peri-Operative/Procedural Considerations

As with any anticoagulant, patients on ELIQUIS who undergo surgery or invasive procedures are at increased risk for bleeding. In these circumstances, temporary discontinuation of ELIQUIS may be required.

Pre-Operative Phase

If an invasive procedure or surgical intervention is required, ELIQUIS should be stopped at least 24 hours before the intervention, if possible, due to increased risk of bleeding, and based on clinical judgment of the physician. If the procedure cannot be delayed, the increased risk of bleeding should be assessed against the urgency of the intervention. Although there are limited data, in patients at higher risk of bleeding or in major surgery where complete hemostasis may be required, consider stopping ELIQUIS at least 48 hours before surgery, depending on clinical circumstances. ELIQUIS should be restarted after surgery or interventional procedures as soon as it has been determined that adequate hemostasis has been established.

Peri-Operative Spinal/Epidural Anesthesia, Lumbar Puncture

When neuraxial (epidural/spinal) anesthesia or spinal puncture is performed, patients treated with antithrombotics for prevention of thromboembolic complications are at risk for developing an epidural or spinal hematoma that may result in long-term neurological injury or permanent paralysis.

The risk of these events is even further increased by the use of indwelling catheters or the concomitant use of drugs affecting hemostasis. Accordingly, indwelling epidural or intrathecal catheters must be removed at least 5 hours prior to the first dose of ELIQUIS. The risk may also be increased by traumatic or repeated epidural or spinal puncture. If traumatic puncture occurs, the administration of ELIQUIS should be delayed for 24 hours.

Patients who have undergone epidural puncture and who are receiving ELIQUIS should be frequently monitored for signs and symptoms of neurological impairment (e.g., numbness or weakness of the legs, bowel or bladder dysfunction). If neurological deficits are noted, urgent diagnosis and treatment is necessary.

The physician should consider the potential benefit versus the risk before neuraxial intervention in patients anticoagulated or to be anticoagulated for thromboprophylaxis and use ELIQUIS only

when the benefits clearly outweigh the possible risks. An epidural catheter should not be withdrawn earlier than 24 hours after the last administration of ELIQUIS.

Post-Procedural Period

ELIQUIS should be restarted following an invasive procedure or surgical intervention as soon as adequate hemostasis has been established and the clinical situation allows, in order to avoid unnecessary increased risk of thrombosis.

Pulmonary

Apixaban is **not** recommended as an alternative to unfractionated heparin for the treatment of VTE in patients with pulmonary embolism who are hemodynamically unstable, or who may receive thrombolysis or pulmonary embolectomy, since the safety and efficacy of ELIQUIS have not been established in these clinical situations.

Patients with antiphospholipid syndrome

Direct acting oral anticoagulants (DOACs), including ELIQUIS, are not recommended for patients with a history of thrombosis who are diagnosed with antiphospholipid syndrome (APS). In particular for patients who are triple positive (for lupus anticoagulant, anticardiolipin antibodies, and anti-beta 2-glycoprotein I antibodies), treatment with DOACs could be associated with increased rates of recurrent thrombotic events compared with vitamin K antagonist therapy. The efficacy and safety of ELIQUIS in patients with APS have not been established.

Renal

Renal Impairment

Determine estimated creatinine clearance (eCrCl) in all patients before instituting ELIQUIS (see DOSAGE AND ADMINISTRATION).

ELIQUIS is not recommended in patients with creatinine clearance < 15 ml/min, or in those undergoing dialysis (see DOSAGE AND ADMINISTRATION, Renal Impairment, and ACTION AND CLINICAL PHARMACOLOGY, Renal Impairment)

Stroke Prevention in Patients with Atrial Fibrillation

No dose adjustment is necessary in patients with mild or moderate renal impairment, or in those with eCrCl 25 - 30 mL/min, unless at least two (2) of the following criteria for dose reduction are met: age \geq 80 years, body weight \leq 60 kg, or patients with serum creatinine \geq 133 micromol/L (1.5 mg/dL). In this case, patients should receive a reduced dose of apixaban 2.5 mg twice daily (see DOSAGE AND ADMINISTRATION).

In patients with eCrCl 15 - 24 mL/min, no dosing recommendation can be made as clinical data are very limited.

Special Populations

Pregnant Women

There are no data from the use of apixaban in pregnant women. Animal studies do not indicate direct or indirect harmful effects with respect to reproductive toxicity. Apixaban is not

recommended during pregnancy.

Nursing Women

It is unknown whether apixaban or its metabolites are excreted in human milk. Available data in animals have shown excretion of apixaban in milk. In rats, this resulted in high milk-to-maternal plasma ratios (apixaban AUC ~ 30, C_{max} ~ 8).

A risk to newborns and infants cannot be excluded. A decision must be made to either discontinue breast-feeding or to discontinue/abstain from ELIQUIS therapy.

Hip Fracture Surgery Patients

Apixaban has not been studied in clinical trials in patients undergoing hip fracture surgery to evaluate efficacy and safety in these patients. Therefore, ELIQUIS is not recommended in these patients.

Pediatrics (< 18 years of age)

The efficacy and safety of ELIQUIS in pediatric patients have not been established (see INDICATIONS AND CLINICAL USE, Pediatrics); therefore, Health Canada has not authorized an indication for pediatric use. Data are available from a single-dose study which evaluated the pharmacokinetics and pharmacodynamics of ELIQUIS in pediatric subjects aged between 28 days to < 18 years at risk for a venous or arterial thrombotic disorder (see **ACTION AND CLINICAL PHARMACOLOGY, Special Populations and Conditions**).

Geriatrics (≥ 65 years of age)

- *Prevention of VTE following elective hip or knee replacement surgery:* No dose adjustment is necessary in elderly patients. Of the total number of patients in clinical studies of apixaban in VTE prevention following major orthopedic surgery (N=5924), 50 percent were 65 and older, while 16 percent were 75 and older.
- *Stroke Prevention in Patients with Atrial Fibrillation (SPAF):* No dose adjustment is necessary in elderly patients, unless the criteria for dose reduction are met (see DOSAGE and ADMINISTRATION). Of the total number of patients in the ARISTOTLE and AVERROES studies, about 69 percent were 65 and older and about 32 percent were 75 and older in these trials.
- *Treatment of DVT and PE and Prevention of recurrent DVT and PE:* No dose adjustment is necessary in elderly patients. But caution is required when prescribing ELIQUIS to elderly patients (≥ 75 years of age). Of the total number of patients in clinical studies of apixaban in VTE treatment and prevention of recurrent DVT and PE (N=7877), about 35 percent were 65 and older, while about 14 percent were 75 and older, respectively.

Monitoring and Laboratory Tests

The pharmacodynamic effects of apixaban are reflective of the mechanism of action, namely Factor-Xa (FXa) inhibition. As a result of FXa inhibition, apixaban prolongs clotting tests such as prothrombin time (PT), and activated partial thromboplastin time (aPTT). Due to their lack of sensitivity, PT or aPTT are not recommended to assess the pharmacodynamic effects of apixaban.

Although ELIQUIS therapy will lead to an elevated INR, depending on the timing of the measurement (see ACTION AND CLINICAL PHARMACOLOGY, Pharmacodynamics), the INR is not a valid measure to assess the anticoagulant activity of ELIQUIS (see also DOSAGE AND ADMINISTRATION, Switching from ELIQUIS to VKA, Considerations for INR Monitoring of VKA Activity during Concomitant ELIQUIS Therapy). The INR is only calibrated and validated for vitamin K antagonists (VKA) and should not be used for any other anticoagulant, including ELIQUIS.

Apixaban demonstrates anti-FXa activity as evident by reduction in Factor-Xa enzyme activity in the Rotachrom® Heparin Anti-Xa assay data from clinical studies. Anti-FXa activity exhibits a close direct linear relationship with apixaban plasma concentration, reaching maximum values at the time of apixaban peak plasma concentrations. The relationship between apixaban plasma concentration and anti-FXa activity is linear over a wide dose range of apixaban. The dose- and concentration-related changes observed following apixaban administration are more pronounced, and less variable, for anti-FXa activity compared to that seen with standard clotting tests, such as PT and aPTT (see ACTION AND CLINICAL PHARMACOLOGY, Pharmacodynamics).

Although there is no need to monitor anticoagulation effect of ELIQUIS during routine clinical practice, in certain infrequent situations such as overdose, acute bleeding, urgent surgery, in cases of suspected non-compliance, or in other unusual circumstances, assessment of the anticoagulant effect of apixaban may be appropriate. Accordingly, a calibrated quantitative anti-FXa assay may be useful to inform clinical decisions in these circumstances. See ACTION AND CLINICAL PHARMACOLOGY, Pharmacodynamics, Table 13, for predicted steady-state peak and trough anti-FXa activity in different indications and for different doses of apixaban.

ADVERSE REACTIONS

Adverse Drug Reaction Overview

Prevention of VTE following Elective Hip or Knee Replacement Surgery

The safety of ELIQUIS (apixaban) 2.5 mg twice daily has been evaluated in one Phase II and three Phase III studies (ADVANCE 1, 2 and 3) including 5,924 patients exposed to apixaban after undergoing major orthopedic surgery of the lower limbs (elective hip replacement or elective knee replacement) and treated for up to 38 days.

Stroke Prevention in Patients with Atrial Fibrillation (SPAF)

The safety of ELIQUIS has been evaluated in the ARISTOTLE and AVERROES studies, including 11,284 patients exposed to apixaban 5 mg twice daily, and 602 patients exposed to apixaban 2.5 mg twice daily. The duration of apixaban exposure was ≥ 12 months for 9,375 patients, and ≥ 24 months for 3,369 patients in the two studies. In ARISTOTLE, 9,088 patients were exposed to apixaban over a mean duration of 89.2 weeks, and 9,052 to dose-adjusted warfarin (INR 2.0 to 3.0) over a mean duration of 87.5 weeks. In AVERROES, 2,798 patients were exposed to apixaban, and 2,780 to ASA, over a mean duration of approximately 59 weeks in both treatment groups.

The overall discontinuation rate due to adverse reactions was 1.8% for apixaban and 2.6% for warfarin in the ARISTOTLE study, and 1.5% for apixaban and 1.3% for ASA in the AVERROES study.

Treatment of DVT and PE and Prevention of recurrent DVT and PE

The safety of ELIQUIS has been evaluated in the AMPLIFY and AMPLIFY-EXT studies, including 2676 patients exposed to ELIQUIS 10 mg twice daily for up to 7 days, 3359 patients exposed to ELIQUIS 5 mg twice daily, and 840 patients exposed to ELIQUIS 2.5 mg twice daily. The mean duration of exposure to apixaban 10 mg twice daily followed by 5 mg twice daily was 154 days and to enoxaparin/warfarin was 152 days in the AMPLIFY study. The mean duration of exposure to either 2.5 mg or 5 mg apixaban was approximately 330 days and to placebo was 312 days in the AMPLIFY-EXT study.

Bleeding

Bleeding is the most relevant adverse reaction of ELIQUIS. Bleeding of any type was observed in approximately 12% of patients treated with ELIQUIS short-term following hip replacement surgery and about 6% following knee replacement surgery. In long-term treatment in patients having atrial fibrillation, bleeding of any type of severity occurred at a rate of 18% per year for patients exposed to ELIQUIS in the ARISTOTLE trial, and 11% per year in the AVERROES trial.

Major or severe bleeding may occur and, regardless of location, may lead to disabling, life-threatening or even fatal outcomes.

Prevention of VTE following Elective Hip or Knee Replacement Surgery

In all Phase III studies, bleeding was assessed beginning with the first dose of double-blind study drug. In studies that compared apixaban to the 40 mg once daily dose of enoxaparin, the first dose of either enoxaparin or injectable placebo was given 9 to 15 hours before surgery. Bleeding during the treatment period for these studies includes events that occurred before the first dose of apixaban, which was given 12-24 hours after surgery. Bleeding during the post-surgery treatment period only included events occurring after the first dose of study drug after surgery. Over half the occurrences of major bleeding in the apixaban group in these two studies occurred prior to the first dose of apixaban. For the study that compared apixaban with enoxaparin given every 12 hours, the first dose of both oral and injectable study drugs was 12-24 hours after surgery. For this study, the treatment period and post-surgery treatment period are identical. Table 2 shows the bleeding results from the treatment period and the post-surgery treatment period.

Table 2 – Bleeding in Patients Undergoing Elective Hip or Knee Replacement Surgery

Bleeding endpoint ^a	ADVANCE-3 Hip replacement surgery		ADVANCE-2 Knee replacement surgery		ADVANCE-1 Knee replacement surgery	
		Apixaban 2.5 mg po bid 35±3 days	Enoxaparin 40 mg sc qd 35±3 days	Apixaban 2.5 mg po bid 12±2 days	Enoxaparin 40 mg sc qd 12±2 days	Apixaban 2.5 mg po bid 12±2 days
	First dose 12 to 24 hours post- surgery	First dose 9 to 15 hours prior to surgery	First dose 12 to 24 hours post- surgery	First dose 9 to 15 hours prior to surgery	First dose 12 to 24 hours post- surgery	First dose 12 to 24 hours post- surgery
All treated	n = 2673	n = 2659	n = 1501	n = 1508	n = 1596	n = 1588
Treatment Period^b						
Major	22 (0.8%)	18 (0.7%)	9 (0.6%)	14 (0.9%)	11 (0.7%)	22 (1.4%)
Fatal	0	0	0	0	0	1 (< 0.1%)
Major +CRNM	129 (4.8%)	134 (5.0%)	53 (3.5%)	72 (4.8%)	46 (2.9%)	68 (4.3%)
All	313 (11.7%)	334 (12.6%)	104 (6.9%)	126 (8.4%)	85 (5.3%)	108 (6.8%)
Post-surgery Treatment Period						
Major	9 (0.3%)	11 (0.4%)	4 (0.3%)	9 (0.6%)	11 (0.7%)	22 (1.4%)
Fatal	0	0	0	0	0	1 (< 0.1%)
Major +CRNM	96 (3.6%)	115 (4.3%)	41 (2.7%)	56 (3.7%)	46 (2.9%)	68 (4.3%)
All	261 (9.8%)	293 (11.0%)	89 (5.9%)	103 (6.8%)	85 (5.3%)	108 (6.8%)

^aAll bleeding criteria included surgical site bleeding.

^b Includes bleeding events which occurred before the first dose of apixaban.

Stroke Prevention in Patients with Atrial Fibrillation (SPAF)

Bleeding events observed in patients with atrial fibrillation are presented below in Tables 3 and 4.

Table 3 – Bleeding Events* in the ARISTOTLE Study

	Apixaban N=9088 n (%/year)	Warfarin N=9052 n (%/year)	Hazard Ratio (95% CI)	p-value
Major*	327 (2.13)	462 (3.09)	0.69 (0.60, 0.80)	< 0.0001
Fatal	10 (0.06)	37 (0.24)		
Intracranial	52 (0.33)	122 (0.80)		
Major + CRNM**	613 (4.07)	877 (6.01)	0.68 (0.61, 0.75)	< 0.0001
All	2356 (18.1)	3060 (25.8)	0.71 (0.68, 0.75)	< 0.0001

Events for each endpoint were counted once per subject but subjects may have contributed events to more than one endpoint

* Dataset includes events occurring on-treatment plus the following two days; Assessed by sequential testing strategy for superiority designed to control the overall type I error in the trial.

** Clinically relevant non-major (CRNM) bleeding - clinically overt bleeding that did not satisfy the criteria for major bleeding and that led to hospital admission, physician- guided medical or surgical treatment, or a change in antithrombotic therapy

Treatment discontinuation due to bleeding-related adverse reactions occurred in 1.7% and 2.5% of patients treated with apixaban and warfarin, respectively.

The incidence of major gastrointestinal bleeds, including upper GI, lower GI, and rectal bleeding, was reported at 0.8% per year with apixaban, and 0.9% per year with warfarin.

In the ARISTOTLE study, concomitant aspirin use with either apixaban or warfarin increased the risk of major bleeding 1.5 to 2 times when compared with those patients not treated with concomitant aspirin. ELIQUIS, like other anticoagulants, should be used with caution in patients treated concomitantly with antiplatelet agents.

Table 4 – Bleeding Events* in the AVERROES Study

	Apixaban N=2798 n (%/year)	Aspirin N=2780 n (%/year)	Hazard Ratio vs Aspirin (95%CI)	p-value
Major	45 (1.41)	29 (0.92)	1.54 (0.96, 2.45)	0.0716
Fatal	5 (0.16)	5 (0.16)		
Intracranial	11 (0.34)	11 (0.35)		
Major + CRNM**	140 (4.46)	101 (3.24)	1.38 (1.07, 1.78)	0.0144
All	325 (10.85)	250 (8.32)	1.30 (1.10, 1.53)	0.0017

Events for each endpoint were counted once per subject but subjects may have contributed events to more than one endpoint.

* Dataset includes events occurring on-treatment, plus the following two days for patients that did not enter open-label extension

** Clinically relevant non-major (CRNM) bleeding, CRNM = clinically overt bleeding that did not satisfy the criteria for major bleeding and that led to hospital admission, physician- guided medical or surgical treatment, or a change in antithrombotic therapy

Treatment discontinuation due to bleeding-related adverse events occurred in 1.5% and 1.3% of patients treated with apixaban and ASA, respectively.

Treatment of DVT and PE and Prevention of recurrent DVT and PE

Bleeding events observed in clinical studies of apixaban in VTE treatment and prevention of recurrent DVT and PE are presented below in Tables 5 and 6.

In the AMPLIFY study, adverse reactions related to bleeding occurred in 417 (15.6%) of apixaban-treated patients compared to 661 (24.6%) of enoxaparin/warfarin-treated patients. The discontinuation rate due to bleeding events was 0.7% in the apixaban-treated patients compared to 1.7% in enoxaparin/warfarin-treated patients in the AMPLIFY study.

Table 5 – Bleeding Events in the AMPLIFY Study

	Apixaban N=2676 n(%)	Enoxaparin/Warfarin N=2689 n(%)	Relative Risk (95% CI)	P-value for superiority
Major	15 (0.6)	49 (1.8)	0.31 (0.17, 0.55)	<0.0001
CRNM†	103 (3.9)	215 (8.0)	0.48 (0.38, 0.60)	
Major + CRNM	115 (4.3)	261 (9.7)	0.44 (0.36, 0.55)	
Minor	313 (11.7)	505 (18.8)	0.62 (0.54, 0.70)	
All	402 (15.0)	676 (25.1)	0.59 (0.53, 0.66)	

† CRNM = clinically relevant non-major bleeding.

Events associated with each endpoint were counted once per subject, but subjects may have contributed events to multiple endpoints.

In the AMPLIFY-EXT study, adverse reactions related to bleeding occurred in 219 (13.3%) of apixaban-treated patients compared to 72 (8.7%) of placebo-treated patients. The discontinuation rate due to bleeding events was approximately 1% in the apixaban-treated patients compared to 0.4% in those patients in the placebo group in the AMPLIFY-EXT study.

Table 6 – Bleeding Events in the AMPLIFY-EXT Study

	Apixaban	Apixaban	Placebo (N=826)	Relative Risk (95% CI)	
	2.5 mg (N=840)	5.0 mg (N=811) n (%)		Apixaban 2.5 mg vs. Placebo	Apixaban 5.0 mg vs. Placebo
Major	2 (0.2)	1 (0.1)	4 (0.5)	0.49 (0.09, 2.64)	0.25 (0.03, 2.24)
CRNM [†]	25 (3.0)	34 (4.2)*	19 (2.3)	1.29 (0.72, 2.33)	1.82 (1.05, 3.18)
Major + CRNM	27 (3.2)	35 (4.3)	22 (2.7)	1.20 (0.69, 2.10)	1.62 (0.96, 2.73)
Minor	75 (8.9)	98 (12.1)*	58 (7.0)	1.26 (0.91, 1.75)	1.70 (1.25, 2.31)
All	94 (11.2)	121 (14.9)*	74 (9.0)	1.24 (0.93, 1.65)	1.65 (1.26, 2.16)

* P-value <0.05, compared to Placebo.

[†] CRNM = clinically relevant non-major bleeding.

Events associated with each endpoint were counted once per subject, but subjects may have contributed events to multiple endpoints.

Clinical Trial Adverse Drug Reactions

Because clinical trials are conducted under very specific conditions the adverse reaction rates observed in the clinical trials may not reflect the rates observed in practice and should not be compared to the rates in the clinical trials of another drug. Adverse drug reaction information from clinical trials is useful for identifying drug-related adverse events and for approximating rates.

Prevention of VTE following Elective Hip or Knee Replacement Surgery

In total, 11% of the patients treated with apixaban 2.5 mg twice daily experienced adverse reactions. Adverse reactions occurring in $\geq 1\%$ of patients undergoing hip or knee replacement surgery in the one Phase II study and the three Phase III studies are listed in Table 7.

Table 7 –Adverse Reactions Occurring in ≥ 1% of Patients in Either Group Undergoing Hip or Knee Replacement Surgery

	Apixaban 2.5 mg BID PO n= 5924 (%)	Enoxaparin 40 mg SC OD or 30 mg SC q12h n= 5904 (%)
GASTROINTESTINAL DISORDERS		
Nausea	153 (2.6)	159 (2.7)
BLOOD AND LYMPHATIC SYSTEM DISORDERS		
Anemia (including post-operative and hemorrhagic anemia, and respective laboratory parameters)	153 (2.6)	178 (3.0)
VASCULAR DISORDERS		
Hemorrhage (including hematoma, and vaginal and urethral hemorrhage)	67 (1.1)	81 (1.4)
INJURY, POISONING AND PROCEDURAL COMPLICATIONS		
Contusion	83 (1.4)	115 (1.9)
Post procedural hemorrhage (including post procedural hematoma, wound hemorrhage, vessel puncture site hematoma and catheter site hemorrhage)	54 (0.9)	60 (1.0)
HEPATOBIILIARY DISORDERS		
Transaminases increased (including alanine aminotransferase increased and alanine aminotransferase abnormal)	50 (0.8)	71 (1.2)
Aspartate aminotransferase increased	47 (0.8)	69 (1.2)
Gamma-glutamyltransferase increased	38 (0.6)	65 (1.1)

Stroke Prevention in Patients with Atrial Fibrillation (SPAF)

Common adverse reactions in patients with atrial fibrillation are shown in Table 8, below.

Table 8 – Adverse Reactions Occurring in ≥ 1% of Patients with Atrial Fibrillation in the ARISTOTLE and AVERROES Studies				
	ARISTOTLE		AVERROES	
	Apixaban N=9088 n (%)	Warfarin N=9052 n (%)	Apixaban N=2798 n (%)	ASA N=2780 n (%)
EYE DISORDERS				
Eye hemorrhage (including conjunctival hemorrhage)	211 (2.3)	326 (3.6)	22 (0.8)	11 (0.4)
GASTROINTESTINAL DISORDERS				
Gastrointestinal hemorrhage (including hematemesis and melena)	194 (2.1)	190 (2.1)	24 (0.9)	23(0.8)
Rectal hemorrhage	141 (1.6)	156 (1.7)	17 (0.6)	6 (0.2)
Gingival bleeding	113 (1.2)	223 (2.5)	19 (0.7)	9 (0.3)
INJURY, POISONING, AND PROCEDURAL COMPLICATIONS				
Contusion	456 (5.0)	745 (8.2)	49 (1.8)	61 (2.2)
RENAL AND URINARY DISORDERS				
Hematuria	340 (3.7)	409 (4.5)	31 (1.1)	17 (0.6)
RESPIRATORY, THORACIC AND MEDIASTINAL DISORDERS				
Epistaxis	560 (6.2)	685 (7.6)	54 (1.9)	52 (1.9)
VASCULAR DISORDERS				
Other hemorrhage	150 (1.7)	188 (2.1)	10 (0.4)	5 (0.2)
Hematoma	233 (2.6)	439 (4.8)	15 (0.5)	24 (0.9)

Treatment of DVT and PE and Prevention of recurrent DVT and PE

Common adverse reactions ($\geq 1\%$) in VTE treatment patients are shown in Table 9, below

Table 9 – Adverse Reactions Occurring in $\geq 1\%$ of Patients in the AMPLIFY and AMPLIFY-EXT Studies

	AMPLIFY		AMPLIFY-EXT	
	Apixaban N=2676 n (%)	Enoxaparin/ Warfarin N=2689 n (%)	Apixaban N=1651 n (%)	Placebo N=826 n (%)
GASTROINTESTINAL DISORDERS				
Gingival bleeding	26 (1.0)	50 (1.9)	21 (1.3)	3 (0.4)
Rectal haemorrhage	26 (1.0)	39 (1.5)	(< 1.0)	(< 1.0)
INJURY, POISONING, AND PROCEDURAL COMPLICATIONS				
Contusion	49 (1.8)	97 (3.6)	27 (1.6)	13 (1.6)
RENAL AND URINARY DISORDERS				
Hematuria	46 (1.7)	102 (3.8)	28 (1.7)	9 (1.1)
RESPIRATORY, THORACIC AND MEDIASTINAL DISORDERS				
Epistaxis	77 (2.9)	146 (5.4)	42 (2.5)	9 (1.1)
Haemoptysis	32 (1.2)	31 (1.2)	(< 1.0)	(< 1.0)
REPRODUCTIVE SYSTEM AND BREAST DISORDERS				
Menorrhagia	38 (1.4)	30 (1.1)	16 (1.0)	2 (0.2)
VASCULAR DISORDERS				
Haematoma	35 (1.3)	76 (2.8)	27 (1.6)	10 (1.2)

Prevention of VTE following Elective Hip or Knee Replacement Surgery

Less common adverse reactions observed in clinical trials in apixaban-treated patients undergoing hip or knee replacement surgery occurring at a frequency of $\geq 0.1\%$ to $< 1\%$ are provided below.

Blood and lymphatic system disorders: thrombocytopenia

Gastrointestinal disorders: gastrointestinal hemorrhage, including hematemesis, melena, and hematochezia

Hepatobiliary disorders: liver function test abnormal, serum alkaline phosphatase increased, serum bilirubin increased

Injury, poisoning and procedural complications: wound secretion, incision site hemorrhage or hematoma, operative hemorrhage

Renal and urinary disorders: hematuria

Respiratory, thoracic and mediastinal disorders: epistaxis

Vascular disorders: hypotension

Less common adverse reactions observed in clinical trials in apixaban-treated patients undergoing hip or knee replacement surgery occurring at a frequency of $< 0.1\%$ are provided below.

Gingival bleeding, hemoptysis, drug hypersensitivity, muscle hemorrhage, ocular hemorrhage (including conjunctival hemorrhage), rectal hemorrhage.

Stroke Prevention in Patients with Atrial Fibrillation (SPAF)

Less common adverse reactions observed in the ARISTOTLE and AVERROES studies in apixaban-treated patients occurring at a frequency of $\geq 0.1\%$ to $< 1\%$ are provided below.

Immune system disorders: Drug hypersensitivity, such as skin rash, anaphylactic reactions

Nervous system disorders: Intracranial hemorrhage, intraspinal hemorrhage or hematoma, subdural hemorrhage, subarachnoid hemorrhage

Vascular disorders: Intra-abdominal hemorrhage

Respiratory, thoracic and mediastinal disorders: Hemoptysis.

Gastrointestinal disorders: hemorrhoidal hemorrhage, hematochezia, retroperitoneal hemorrhage ($< 0.1\%$)

Reproductive system and breast disorders: Abnormal vaginal hemorrhage, hematuria

Injury, poisoning and procedural complications: Post-procedural hemorrhage, traumatic hemorrhage, incision site hemorrhage

Investigations: Occult blood positive

Treatment of DVT and PE and Prevention of recurrent DVT and PE

Less common adverse reactions observed in the AMPLIFY and AMPLIFY-EXT trials in apixaban-treated patients occurring at a frequency of $\geq 0.1\%$ to $< 1\%$ are provided below:

Eye disorders: Conjunctival haemorrhage, retinal haemorrhage

Gastrointestinal disorders: Haematochezia, haemorrhoidal haemorrhage, gastrointestinal, haemorrhage, haematemesis

Skin and subcutaneous tissue disorders: Ecchymosis, skin haemorrhage

Reproductive system and breast disorders: Vaginal haemorrhage, metrorrhagia, menometrorrhagia, genital haemorrhage

General disorders and administration site conditions: Injection site haematoma, vessel puncture site haematoma

Laboratory investigation: Blood urine present, occult blood positive

Injury, poisoning, and procedural complications: Wound haemorrhage, post procedural haemorrhage, traumatic haematoma

DRUG INTERACTIONS

CYP Inhibition

ELIQUIS (apixaban) does not inhibit CYP 3A4 or any other major CYP isoenzymes. *In vitro* apixaban studies showed no inhibitory effect on the activity of CYP 1A2, CYP 2A6, CYP 2B6, CYP 2C8, CYP 2C9, CYP 2D6 or CYP 3A4 ($IC_{50} > 45 \mu M$) and weak inhibitory effect on the activity of CYP 2C19 ($IC_{50} > 20 \mu M$) at concentrations that are significantly greater than peak plasma concentrations observed in patients.

CYP Induction

ELIQUIS does not induce CYP 3A4 or any other major CYP isoenzymes. Apixaban did not induce CYP 1A2, CYP 2B6, CYP 3A4/5 at a concentration up to $20 \mu M$.

P-gp Inhibition

ELIQUIS does not inhibit P-gp based on *in vitro* data.

Drug-Drug Interactions

Apixaban is metabolized mainly via CYP 3A4/5 with minor contributions from CYP 1A2, 2C8, 2C9, 2C19, and 2J2. Apixaban is a substrate of transport proteins, P-glycoprotein (P-gp) and breast cancer resistance protein (BCRP).

Inhibitors of Both CYP 3A4 and P-gp

Co-administration of apixaban with ketoconazole 400 mg q.d., a strong inhibitor of both CYP 3A4 and P-gp, led to a 2-fold increase in apixaban mean AUC and a 1.6-fold increase in apixaban C_{max} . The use of ELIQUIS is contraindicated in patients receiving concomitant systemic treatment with strong inhibitors of **both** CYP 3A4 and P-gp, such as azole-antimycotics (e.g., ketoconazole, itraconazole, voriconazole, or posaconazole), and HIV protease inhibitors (e.g., ritonavir) (see CONTRAINDICATIONS, and WARNINGS AND PRECAUTIONS, *Inhibitors of Both CYP 3A4 and P-gp*).

Active substances moderately inhibiting the apixaban elimination pathways, CYP 3A4 and/or P-gp, are expected to increase apixaban plasma concentrations to a lesser extent. No dose adjustment for apixaban is required when co-administered with agents that are not strong inhibitors of **both** CYP3A4 and P-gp. For example, diltiazem 360 mg q.d. led to a 1.4 and 1.3-fold increase in mean apixaban AUC and C_{max} , respectively. Naproxen (500 mg, single dose), an inhibitor of P-gp, led to a 1.5 and 1.6-fold increase in mean apixaban AUC and C_{max} , respectively. Clarithromycin (500 mg, twice daily), an inhibitor of P-gp and a strong inhibitor of CYP3A4, led to a 1.6-fold and 1.3-fold increase in mean apixaban AUC and C_{max} , respectively. (see WARNINGS AND PRECAUTIONS, Bleeding, and DOSAGE AND ADMINISTRATION, Concomitant Use with CYP 3A4 and P-gp Inhibitors/Inducers).

Inducers of Both CYP 3A4 and P-gp

Co-administration of apixaban with rifampicin 600 mg q.d., a strong inducer of both CYP 3A4 and P-gp, led to an approximate 54% and 42% decrease in mean apixaban AUC and C_{max} , respectively. The concomitant use of apixaban with other strong inducers of both CYP 3A4 and P-gp (e.g., phenytoin, carbamazepine, phenobarbital or St. John's Wort) may also lead to reduced apixaban plasma concentrations and should generally be avoided. (see WARNINGS AND PRECAUTIONS, Inducers of Both CYP 3A4 and P-gp, and DOSAGE AND ADMINISTRATION, Concomitant Use with CYP 3A4 and P-gp Inhibitors/Inducers).

Increased stroke rates, and paradoxically, increased major bleeding have been noted in patients with atrial fibrillation taking these drugs with either apixaban or warfarin.

Drug Products Affecting Hemostasis

The concomitant use of ELIQUIS with drugs affecting hemostasis, including antiplatelet agents increases the risk of bleeding (see WARNINGS AND PRECAUTIONS, Bleeding). Care is to be taken if patients are treated concomitantly with drug products affecting hemostasis such as non-steroidal anti-inflammatory drugs (NSAID), acetylsalicylic acid (ASA), platelet aggregation inhibitors, selective serotonin reuptake inhibitors (SSRI), or serotonin norepinephrine reuptake inhibitors (SNRIs).

If concomitant antiplatelet therapy is contemplated, a careful assessment of the potential risks should be made against potential benefits, weighing risk of increased bleeding against expected benefit. In clinical trials conducted in patients with atrial fibrillation, the addition of ASA or dual antiplatelet therapy to apixaban did not decrease the incidence of stroke but increased the incidence of major bleeding (see ADVERSE REACTIONS, Bleeding, *Stroke Prevention in Patients with Atrial Fibrillation*, and DOSAGE AND ADMINISTRATION, Concomitant Use of Antiplatelet Agents).

For concomitant treatment with any other anticoagulant, see CONTRAINDICATIONS.

Table 10 – Summary of Drug-Drug Interactions

Proper Name	Reference	Effect	Clinical Comment
Ketoconazole	CT	Co-administration of apixaban with ketoconazole (400 mg once a day), a strong inhibitor of both CYP 3A4 and P-gp, led to a 2-fold increase in mean apixaban AUC and a 1.6-fold increase in mean apixaban C _{max} .	The use of ELIQUIS is contraindicated in patients receiving concomitant systemic treatment with strong inhibitors of both CYP 3A4 and P-gp, such as ketoconazole, itraconazole, voriconazole, posaconazole and ritonavir (see CONTRAINDICATIONS).
Diltiazem	CT	Diltiazem (360 mg once a day), considered a moderate CYP 3A4 and a weak P-gp inhibitor, led to a 1.4 fold increase in mean apixaban AUC and a 1.3 fold increase in C _{max} . Other moderate inhibitors of CYP 3A4 and/or P-gp, such as amiodarone and dronedarone, are expected to have similar effect.	No dose adjustment for apixaban is required. Use with caution.

Table 10 – Summary of Drug-Drug Interactions

Proper Name	Reference	Effect	Clinical Comment
Naproxen	CT	<p>A single dose of naproxen 500 mg, an inhibitor of P-gp but not an inhibitor of CYP3A4, led to a 1.5-fold and 1.6-fold increase in mean apixaban AUC and C_{max}, respectively. A corresponding 63% increase in mean anti-Xa activity at 3 hours post-dose was observed when apixaban was co-administered with naproxen.</p> <p>Apixaban had no effect on naproxen AUC or C_{max}. No changes were observed in the usual effect of naproxen on (arachidonic acid-induced) platelet aggregation.</p>	No dose adjustment for either agent is required. Use with caution.
Clarithromycin	CT	Clarithromycin (500 mg, twice daily), an inhibitor of P-gp and a strong inhibitor of CYP3A4, led to a 1.6-fold and 1.3-fold increase in mean apixaban AUC and C _{max} respectively.	No dosage adjustment for apixaban is required. Use with caution.
Rifampin	CT	Co-administration of apixaban with rifampin, a strong inducer of both CYP 3A4 and P-gp, rifampin, led to an approximate 54% and 42% decrease in mean apixaban AUC and C _{max} , respectively.	Combined use with strong inducers of both CYP 3A4 and P-gp should generally be avoided, since efficacy of ELIQUIS may be compromised (see WARNINGS AND PRECAUTIONS, Inducers of Both CYP 3A4 and P-gp).
Enoxaparin	CT	Enoxaparin had no effect on the pharmacokinetics of apixaban. After combined administration of enoxaparin (40 mg single dose) with apixaban (5 mg single dose), an additive effect on anti-Factor-Xa activity was observed.	Concomitant use of apixaban with enoxaparin is contraindicated (see CONTRAINDICATIONS).
Acetylsalicylic acid (ASA)	CT	Pharmacokinetic interactions were not evident when apixaban was co-administered with acetylsalicylic acid 325 mg once a day.	No dose adjustment for either agent is required, but bleeding risk is increased (see WARNINGS AND PRECAUTIONS, Bleeding, and ADVERSE REACTIONS, Bleeding, SPAF). Assess bleeding risk before co-administration, and use with caution, if deemed necessary.

Table 10 – Summary of Drug-Drug Interactions

Proper Name	Reference	Effect	Clinical Comment
Clopidogrel	CT	Pharmacokinetic interactions were not evident when apixaban was co-administered with clopidogrel 75mg OD or with the combination of clopidogrel 75 mg and acetylsalicylic acid 162 mg OD	Concomitant use of ASA or dual antiplatelet therapy with either ELIQUIS or warfarin increases the risk of major bleeding in patients with atrial fibrillation. Assess bleeding risk before co-administration, and use with caution, if deemed necessary (see WARNINGS AND PRECAUTIONS, Bleeding).
Atenolol	CT	Coadministration of a single dose of apixaban (10 mg) and atenolol (100 mg), a common beta-blocker, did not alter the pharmacokinetics of atenolol or have a clinically relevant effect on apixaban pharmacokinetics. Following administration of the two drugs together, mean apixaban AUC and C _{max} were 15% and 18% lower than when administered alone.	No dose adjustment for either agent is required.
Famotidine		The administration of apixaban 10 mg with famotidine 40 mg had no effect on apixaban AUC or C _{max} .	No dose adjustment for apixaban is required when co-administered with famotidine. These data indicate that apixaban pharmacokinetics are not likely to be altered by changes in gastric pH or co-administration with other organic cation transport inhibitors.
Digoxin	CT	Co-administration of apixaban (20 mg once a day) and digoxin (0.25 mg once a day), a P-gp substrate, did not affect digoxin AUC or C _{max} .	No dose adjustment for digoxin is required. Apixaban does not inhibit P-gp mediated substrate transport.
Prasugrel	CT	No clinically relevant pharmacokinetic interactions were evident when apixaban (5mg bid) was co-administered with prasugrel (60 mg followed by 10 mg once daily).	Concomitant use of apixaban and prasugrel is not recommended (see WARNINGS AND PRECAUTIONS, Bleeding).
Charcoal (activated)	CT	Administration of activated charcoal (50 g charcoal and 96 g sorbitol in 240 ml of water) 2 hours and 6 hours after apixaban 20 mg, resulted in a mean 50% and 27% decrease in apixaban AUC, respectively.	May be useful in overdosage or accidental ingestion (see OVERDOSAGE).

Table 10 – Summary of Drug-Drug Interactions

Proper Name	Reference	Effect	Clinical Comment
Selective serotonin reuptake inhibitors (SSRI), and serotonin norepinephrine reuptake inhibitors (SNRIs)	T, CT	Serotonin release by platelets plays an important role in hemostasis. Case reports and epidemiological studies (case-control and cohort design) have demonstrated an association between use of drugs that interfere with serotonin reuptake and the occurrence of gastrointestinal bleeding. Bleeding events related to SSRIs and SNRIs use have ranged from ecchymoses, hematomas, epistaxis, and petechiae to life-threatening hemorrhages.	ELIQUIS should be used with caution when co-administered with selective serotonin reuptake inhibitors (SSRIs) or serotonin norepinephrine reuptake inhibitors (SNRIs) because these medicinal products typically increase the bleeding risk. Patients should be advised of signs and symptoms of blood loss and to report them immediately or go to an emergency room (see WARNINGS AND PRECAUTIONS).

Legend: CT = Clinical Trial; T = Theoretical

Drug-Food Interactions

ELIQUIS can be taken with or without food (see DOSAGE AND ADMINISTRATION, and ACTION AND CLINICAL PHARMACOLOGY, Pharmacokinetics, *Absorption*).

Drug-Herb Interactions

The concomitant use of ELIQUIS with strong inducers of **both** CYP 3A4 and P-gp inducers (e.g. St. John's Wort) may lead to reduced apixaban plasma concentrations. Combined use with strong inducers of both CYP 3A4 and P-gp should generally be avoided, since efficacy of ELIQUIS may be compromised (see WARNINGS AND PRECAUTIONS, Inducers of Both CYP 3A4 and P-gp).

Drug-Laboratory Interactions

Clotting tests, e.g., PT (including INR), and aPTT, are affected as may be expected by the mechanism of action of apixaban (see ACTION AND CLINICAL PHARMACOLOGY, Pharmacodynamics). Changes observed in these clotting tests at the expected therapeutic dose are relatively small, subject to noteworthy variability, and are not useful for assessing the anticoagulant effect of apixaban (see WARNINGS AND PRECAUTIONS, Monitoring and Laboratory Tests).

DOSAGE AND ADMINISTRATION

As for any non-vitamin K antagonist oral anticoagulant (NOAC) drug, before initiating ELIQUIS (apixaban), ensure that the patient understands and is prepared to accept adherence to NOAC

therapy, as directed.

ELIQUIS (apixaban) can be taken with or without food.

ELIQUIS should be taken regularly, as prescribed, to ensure optimal effectiveness. All temporary discontinuations should be avoided, unless medically indicated.

For patients unable to swallow whole tablets, ELIQUIS tablets may be crushed to a fine powder using a mortar and pestle or an adequate device designed for this purpose, suspended in water or mixed with applesauce. The suggested procedures are shown in **PART III, PROPER USE OF THIS MEDICATION – If you have trouble swallowing the tablet(s)**. The suspended crushed tablet(s) should be administered immediately after preparation (see ACTION AND CLINICAL PHARMACOLOGY – Pharmacokinetics)

Determine estimated creatinine clearance (eCrCl) in all patients before instituting ELIQUIS, and monitor renal function during ELIQUIS treatment, as clinically appropriate. Determination of renal function by eCrCl should occur at least once per year, and especially during circumstances when renal function may be expected to be compromised, i.e., acute myocardial infarction (AMI), acute decompensated heart failure (AHF), increased use of diuretics, dehydration, hypovolemia, etc. Clinically relevant deterioration of renal function may require dosage adjustment or discontinuation of ELIQUIS (see below, Renal Impairment).

Glomerular filtration rate may be estimated by calculating eCrCl, using the Cockcroft-Gault formula:

eCrCl (mL/min)=

in males: $\frac{(140-\text{age}) (\text{years}) \times \text{weight} (\text{kg}) \times 1.23}{\text{serum creatinine} (\mu\text{mol/L})}$ or, $\frac{(140-\text{age}) (\text{yrs}) \times \text{weight} (\text{kg})}{72 \times \text{serum creatinine} (\text{mg}/100 \text{ mL})}$

in females: $\frac{(140-\text{age}) (\text{years}) \times \text{weight} (\text{kg}) \times 1.04}{\text{serum creatinine} (\mu\text{mol/L})}$ or, $\frac{(140-\text{age}) (\text{yrs}) \times \text{weight} (\text{kg}) \times 0.85}{72 \times \text{serum creatinine} (\text{mg}/100 \text{ mL})}$

Recommended Dose and Dosage Adjustment

Prevention of VTE following Elective Hip or Knee Replacement Surgery

The recommended dose of ELIQUIS is 2.5 mg twice daily. The initial dose should be taken 12 to 24 hours after surgery, and after hemostasis has been obtained.

In patients undergoing hip replacement surgery, the recommended duration of treatment is 32 to 38 days.

In patients undergoing knee replacement surgery, the recommended duration of treatment is 10 to 14 days.

Stroke Prevention in Patients with Atrial Fibrillation

The recommended dose of ELIQUIS is 5 mg taken orally twice daily.

In patients fulfilling at least two (2) of the following criteria, a reduced dose of ELIQUIS 2.5 mg twice daily is recommended: age \geq 80 years, body weight \leq 60 kg, or serum creatinine \geq 133 micromole/L (1.5 mg/dL). These patients have been determined to be at higher risk of bleeding.

Treatment of DVT and PE and Prevention of recurrent DVT and PE

The recommended dose of ELIQUIS for the treatment of acute DVT or PE is 10 mg taken orally twice daily for 7 days, followed by 5 mg taken orally twice daily.

The duration of therapy should be individualised after careful assessment of the treatment benefit against the risk of bleeding. Short duration of therapy (at least 3 months) should be based on transient risk factors (e.g. recent surgery, trauma, immobilisation) and extended duration should be based on permanent risk factors or idiopathic DVT or PE.

Further to the course of a minimum of 6 months of treatment for DVT or PE, the recommended dose for the continued prevention of recurrent DVT and PE is 2.5 mg taken orally twice daily.

Special Populations

Renal Impairment

Prevention of VTE following Elective Hip or Knee Replacement Surgery

Treatment of DVT and PE and Prevention of recurrent DVT and PE

No dose adjustment is necessary in patients with mild or moderate renal impairment (eCrCl \geq 30 mL/min) (see ACTION AND CLINICAL PHARMACOLOGY, Renal Impairment).

Limited clinical data in patients with severe renal impairment (eCrCl 15-29 mL/min) indicate that apixaban plasma concentrations are increased. Therefore, apixaban is to be used with caution in these patients because of potentially higher bleeding risk.

Because there is very limited clinical experience in patients with creatinine clearance $<$ 15 mL/min, and there are no data in patients undergoing dialysis, apixaban is not recommended in these patients (see WARNINGS AND PRECAUTIONS, Renal Impairment, and ACTION AND CLINICAL PHARMACOLOGY, Renal Impairment).

A summarized dosing table is presented in Table 11 below.

Table 11 – Dosage and Administration for Patients According to Renal Function

Indication	Renal Impairment				
	Normal	Mild	Moderate	Severe	
Creatinine Clearance (eCrCl)	> 80 mL/min	>50-≤80 mL/min	≥30-≤50 mL/min	≥15-<30 mL/min	<15 mL/min or patients undergoing dialysis
Prevention of VTE in adult patients after elective knee or hip replacement surgery	2.5 mg bid			2.5 mg bid [†]	
Treatment of VTE (DVT, PE)	10 mg bid 7 days, followed by 5 mg bid			10 mg bid 7 days, followed by 5 mg bid [†]	
Continued prevention of recurrent DVT and PE [‡]	2.5 mg bid			2.5 mg bid [†]	

[†] Must be used with caution due to potentially higher bleeding risks.

[‡] After a minimum of 6 months of treatment for DVT or PE.

bid = twice daily

Stroke Prevention in Patients with Atrial Fibrillation

No dose adjustment is necessary in patients with mild or moderate renal impairment, or in those with eCrCl 25 – 30 mL/min, unless at least two (2) of the following criteria for dose reduction are met: age ≥ 80 years, body weight ≤ 60 kg, or patients with serum creatinine ≥ 133 micromol/L (1.5 mg/dL). In this case, patients should receive a dose of apixaban 2.5 mg twice daily.

In patients with eCrCl 15 - 24 mL/min, no dosing recommendation can be made as clinical data are very limited.

Because there are no data in patients with creatinine clearance < 15 ml/min, or in those undergoing dialysis, apixaban is not recommended in these patients (see ACTION AND CLINICAL PHARMACOLOGY, Renal Impairment).

A summarized dosing table is presented in Table 12 below.

Table 12 – Dosage and Administration for Patients According to Renal Function

Creatinine Clearance (eCrCl)	Renal Impairment					
	Normal	Mild	Moderate	Severe		
Indication	> 80 mL/min	>50-≤80 mL/min	>30-≤50 mL/min	≥25-≤30 mL/min	≥15-≤24 mL/min	<15 mL/min or patients undergoing dialysis
Prevention of stroke and systemic embolism in patients with atrial fibrillation	5 mg bid Dose adjustment to 2.5 mg bid, if ≥2 of following criteria are met [§] : <ul style="list-style-type: none"> • age ≥ 80 years • body weight ≤60 kg • serum creatinine ≥133 μmol/L (1.5 mg/dL) 				No dosing recommendation due to very limited clinical data	ELIQUIS is not recommended

§ These patients have been determined to be at higher risk of bleeding.

Hepatic Impairment

ELIQUIS is contraindicated in patients with hepatic disease associated with coagulopathy and clinically relevant bleeding risk (see CONTRAINDICATIONS).

ELIQUIS is not recommended in patients with severe hepatic impairment (see WARNINGS AND PRECAUTIONS, Hepatic Impairment, and ACTION AND CLINICAL PHARMACOLOGY, Pharmacokinetics).

ELIQUIS should be used with caution in patients with mild or moderate hepatic impairment (Child Pugh A or B). No dose adjustment is required in patients with mild or moderate hepatic impairment (see WARNINGS AND PRECAUTIONS, Hepatic Impairment, and ACTION AND CLINICAL PHARMACOLOGY, Hepatic Impairment).

Patients with elevated liver enzymes (ALT/AST > 2 x ULN, or total bilirubin ≥ 1.5 x ULN) were excluded in clinical trials. Therefore, ELIQUIS should be used with caution in these patients.

Concomitant Use of Antiplatelet Agents

The concomitant use of ELIQUIS with antiplatelet agents increases the risk of bleeding (see WARNINGS AND PRECAUTIONS, Bleeding). If concomitant antiplatelet therapy is contemplated for indications related to coronary artery disease, a careful assessment of the

potential risks should be made against potential benefits, weighing risk of increased bleeding against expected benefit (see ADVERSE REACTIONS, Bleeding, *Stroke Prevention in Patients with Atrial Fibrillation*, and DRUG INTERACTIONS, Drug Products Affecting Hemostasis).

Concomitant Use with CYP 3A4 and P-gp Inhibitors/Inducers

Inhibitors of Both CYP 3A4 and P-gp

The use of ELIQUIS is contraindicated in patients receiving concomitant systemic treatment with strong inhibitors of **both** CYP 3A4 and P-gp, such as azole-antimycotics (e.g., ketoconazole, itraconazole, voriconazole, or posaconazole), and HIV protease inhibitors (e.g., ritonavir) (see CONTRAINDICATIONS, and WARNINGS AND PRECAUTIONS, Inhibitors of Both CYP 3A4 and P-gp).

Drugs moderately inhibiting the apixaban elimination pathways, CYP 3A4 and/or P-gp, would be expected to increase apixaban plasma concentrations to a lesser extent. For example, concomitant administration of diltiazem led to a 40% increase in apixaban AUC, while naproxen, an inhibitor of P-gp, led to a 50% increase in apixaban AUC and clarithromycin, an inhibitor of P-gp, led to a 60% increase in apixaban AUC. No dose adjustment for apixaban is required when co-administered with less potent inhibitors of CYP 3A4 and/or P-gp (see WARNINGS AND PRECAUTIONS, Bleeding and DRUG INTERACTIONS, Table 10).

Inducers of Both CYP 3A4 and P-gp

Co-administration of apixaban with rifampicin, a strong inducer of **both** CYP 3A4 and P-gp, led to an approximate 54% decrease in apixaban AUC. The concomitant use of apixaban with other strong inducers of **both** CYP 3A4 and P-gp (e.g., phenytoin, carbamazepine, phenobarbital or St. John's Wort) may also lead to reduced apixaban plasma concentrations. Combined use of ELIQUIS with strong inducers of both CYP 3A4 and P-gp should generally be avoided since efficacy of ELIQUIS may be compromised. (see WARNINGS AND PRECAUTIONS, Inducers of Both CYP 3A4 and P-gp).

Body Weight

Prevention of VTE following Elective Hip or Knee Replacement Surgery

No dose adjustment required.

Stroke Prevention in Patients with Atrial Fibrillation

No dose adjustment is generally required. However, patients fulfilling at least two (2) of the following characteristics: age \geq 80 years, body weight \leq 60 kg, or serum creatinine \geq 133 micromole/L (1.5 mg/dL), should receive a reduced dose of apixaban 2.5 mg twice daily.

Treatment of DVT and PE and Prevention of recurrent DVT and PE

No dose adjustment required

Gender

No dose adjustment required.

Ethnicity

No dose adjustment required.

Pediatrics (< 18 years of age)

The safety and effectiveness of ELIQUIS in pediatric patients have not been established; therefore, Health Canada has not authorized an indication for pediatric use.

Geriatrics (≥ 65 years of age)

Prevention of VTE following Elective Hip or Knee Replacement Surgery

No dose adjustment required (see WARNINGS AND PRECAUTIONS, Geriatrics, and ACTION AND CLINICAL PHARMACOLOGY, Geriatrics).

Stroke Prevention in Patients with Atrial Fibrillation

No dose adjustment is generally required. However, patients fulfilling at least two (2) of the following characteristics: age ≥ 80 years, body weight ≤ 60 kg, or serum creatinine ≥ 133 micromole/L (1.5 mg/dL), should receive a reduced dose of apixaban 2.5 mg twice daily.

Treatment of DVT and PE and Prevention of recurrent DVT and PE

Although no dose adjustment required, caution is advised when prescribing ELIQUIS to elderly patients (≥ 75 years of age (see WARNINGS AND PRECAUTIONS, Geriatrics, and ACTION AND CLINICAL PHARMACOLOGY, Geriatrics).

Cardioversion

Patients can be maintained on ELIQUIS while being cardioverted (see ACTION AND CLINICAL PHARMACOLOGY, Cardioversion).

Switching from or to parenteral anticoagulants

In general, switching treatment from parenteral anticoagulants to ELIQUIS (or *vice versa*) can be done at the next scheduled dose.

Switching from vitamin K antagonists (VKA) to ELIQUIS

When switching patients from a VKA, such as warfarin, to ELIQUIS, discontinue warfarin or other VKA therapy, and start ELIQUIS when the international normalized ration (INR) is below 2.0.

Switching from ELIQUIS to VKA

As with any short-acting anticoagulant, there is a potential for inadequate anticoagulation when transitioning from ELIQUIS to a VKA. It is important to maintain an adequate level of anticoagulation when transitioning patients from one anticoagulant to another.

ELIQUIS should be continued concurrently with the VKA until the INR is ≥ 2.0 . For the first 2 days of the conversion period, the VKA can be given in the usual starting doses without INR testing (see Considerations for INR Monitoring of VKA Activity during Concomitant ELIQUIS Therapy). Thereafter, while on concomitant therapy, the INR should be tested just prior to the next dose of ELIQUIS, as appropriate. ELIQUIS can be discontinued once the INR is > 2.0 . Once ELIQUIS is discontinued, INR testing may be done at least 12 hours after the last dose of ELIQUIS, and should then reliably reflect the anticoagulant effect of the VKA.

Considerations for INR Monitoring of VKA Activity during Concomitant ELIQUIS Therapy

In general, after starting VKA therapy, the initial anticoagulant effect is not readily apparent for at least 2 days, while the full therapeutic effect is achieved in 5-7 days. Consequently, INR monitoring in the first 2 days after starting a VKA is rarely necessary. Likewise, the INR may remain increased for a number of days after stopping VKA therapy.

Although ELIQUIS therapy will lead to an elevated INR, depending on the timing of the measurement (see ACTION AND CLINICAL PHARMACOLOGY, Pharmacodynamics), the INR is not a valid measure to assess the anticoagulant activity of ELIQUIS. The INR is only calibrated and validated for VKA and should not be used for any other anticoagulant, including ELIQUIS.

When switching patients from ELIQUIS to a VKA, the INR should only be used to assess the anticoagulant effect of the VKA, and not that of ELIQUIS. Therefore, while patients are concurrently receiving ELIQUIS and VKA therapy, if the INR is to be tested, it should not be before 12 hours after the previous dose of ELIQUIS, and should be just prior to the next dose of ELIQUIS, since at this time the remaining ELIQUIS concentration in the circulation is too low to have a clinically important effect on the INR. If INR testing is done earlier than just prior to the next dose of ELIQUIS, the reported INR will not reflect the anticoagulation effect of the VKA

only, because ELIQUIS use may also affect the INR, leading to aberrant readings (see ACTION AND CLINICAL PHARMACOLOGY, Pharmacodynamics).

Missed Dose

If a dose is missed, the patient should take ELIQUIS immediately and then continue with twice daily administration as before. A double dose should not be taken to make up for a missed tablet.

OVERDOSAGE

For management of a suspected drug overdose, contact your regional Poison Control Centre.

Overdose of ELIQUIS (apixaban) may lead to hemorrhagic complications, due to its pharmacologic properties.

A specific antidote for ELIQUIS is not available. In healthy subjects, administration of activated charcoal 2 and 6 hours after ingestion of a 20-mg dose of apixaban reduced mean apixaban AUC by 50% and 27%, respectively, and had no impact on C_{max} . Mean half-life of apixaban decreased from 13.4 hours when apixaban was administered alone to 5.3 hours and 4.9 hours, respectively, when activated charcoal was administered 2 and 6 hours after apixaban. Thus, administration of activated charcoal may be useful to reduce absorption and systemic exposure of apixaban in the management of overdose or accidental ingestion.

Hemodialysis decreased apixaban AUC by 14% in subjects with end stage renal disease, when a single dose of apixaban 5 mg was administered orally. Apixaban protein binding has been shown to be over 90% in subjects with end-stage renal disease. Therefore, hemodialysis is unlikely to be an effective means of managing apixaban overdose (see ACTION AND CLINICAL PHARMACOLOGY, Renal Impairment).

Management of Bleeding

In the event of hemorrhagic complications in a patient receiving ELIQUIS, treatment must be discontinued, and the source of bleeding investigated. Appropriate standard treatment, e.g. surgical hemostasis as indicated and blood volume replacement, should be undertaken. In addition, consideration may be given to the use of fresh whole blood or the transfusion of fresh frozen plasma.

If bleeding cannot be controlled by the above measures, consider administration of one of the following procoagulants:

- activated prothrombin complex concentrate (APCC), e.g., FEIBA
- prothrombin complex concentrate (PCC)
- recombinant Factor-VIIa (rFVIIa)

Reversal of apixaban anticoagulant activity was evaluated by measuring endogenous thrombin potential (ETP) to assess thrombin generation using two different 4-factor PCC (prothrombin complex concentrate), one with and the other without heparin, in an open-label randomized, placebo-controlled study in 15 healthy adult subjects administered ELIQUIS 10 mg twice

daily. Reversal of the steady-state anticoagulant effect was observed 30 minutes after the start of a single infusion of either one of the PCC products indicating potential usefulness in the management of patients.

However, there are currently no clinical studies supporting the effectiveness of PCC in ELIQUIS-treated patients.

Currently, there is no experience with the use of recombinant factor VIIa in individuals receiving ELIQUIS.

Protamine sulfate and vitamin K are not expected to affect the anticoagulant activity of ELIQUIS. There is no experience with antifibrinolytic agents (tranexamic acid, aminocaproic acid) in individuals receiving ELIQUIS. There is neither scientific rationale for benefit or experience with the systemic hemostatics, e.g., desmopressin and aprotinin in individuals receiving ELIQUIS.

A calibrated quantitative anti-FXa assay may be useful to confirm excess apixaban exposure and help to inform clinical decisions in circumstances of clinical overdose (see ACTION AND CLINICAL PHARMACOLOGY, Pharmacodynamics). INR should **NOT** be used to assess the anticoagulant effect of ELIQUIS (see WARNINGS AND PRECAUTIONS, Monitoring and Laboratory Tests, and ACTION AND CLINICAL PHARMACOLOGY, Pharmacodynamics).

ACTION AND CLINICAL PHARMACOLOGY

Mechanism of Action

ELIQUIS (apixaban) is a potent, oral, reversible, direct and highly selective active site inhibitor of Factor-Xa. It does not require antithrombin III for antithrombotic activity. Apixaban inhibits free and clot-bound Factor-Xa, and prothrombinase activity. Activation of Factor-X to Factor-Xa (FXa) via the intrinsic and extrinsic pathway plays a central role in the cascade of blood coagulation. Apixaban has no direct effects on platelet aggregation, but indirectly inhibits platelet aggregation induced by thrombin. By inhibiting Factor-Xa, apixaban prevents thrombin generation and thrombus development. Preclinical studies of apixaban in animal models have demonstrated antithrombotic efficacy in the prevention of arterial and venous thrombosis at doses that preserved hemostasis.

Pharmacodynamics

There is a clear correlation between plasma apixaban concentration and degree of anticoagulant effect. The maximum effect of apixaban on pharmacodynamic parameters occurs at the same time as C_{max} . The pharmacodynamic effects include the prolongation of clotting tests such as PT (including INR), and aPTT, as well as inhibition of FXa activity and *ex vivo* thrombin generation.

- The relationship between INR and apixaban plasma concentration was best described by a linear model, whereas that between aPTT and apixaban plasma concentration was best described by an E_{max} model. Both tests were subject to a high degree of variability and lacked sufficient sensitivity to gauge apixaban exposure. These tests are not recommended to assess the pharmacodynamic effects of apixaban.

- Anti-FXa activity, as measured by the Rotachrom® Heparin Anti-Xa assay and WHO LMWH standards, exhibits a close direct linear relationship with apixaban plasma concentration ($R^2 = .89$). The relationship between apixaban plasma concentration and anti-FXa activity is linear over a wide dose range of apixaban and subject populations. Precision of the Rotachrom assay is well within acceptable limits for use in a clinical laboratory. Thus, a calibrated quantitative anti-FXa assay may be useful in situations where knowledge of apixaban exposure may help to inform clinical decisions.

Table 13 below shows the predicted steady state exposure and anti-Factor Xa activity for each indication. In patients taking apixaban for the prevention of VTE following hip or knee replacement surgery, the results demonstrate a less than 1.6-fold fluctuation in peak-to-trough levels. In nonvalvular atrial fibrillation patients taking apixaban for the prevention of stroke and systemic embolism, the results demonstrate a less than 1.7-fold fluctuation in peak-to-trough levels. In patients taking apixaban for the treatment of VTE or prevention of recurrence of VTE, the results demonstrate a less than 2.2-fold fluctuation in peak-to-trough levels.

Table 13– Predicted Apixaban Steady-state Exposure (ng/mL) and Anti-FXa Activity (IU/mL)

	Apixaban C _{max}	Apixaban C _{min}	Apixaban Anti-FXa Activity Max	Apixaban Anti-FXa Activity Min
	Median [5th, 95th Percentile]			
<i>Prevention of VTE: elective hip or knee replacement surgery</i>				
2.5 mg BID	77 [41, 146]	51 [23, 109]	1.3 [0.67, 2.4]	0.84 [0.37, 1.8]
<i>Prevention of stroke and systemic embolism: NVAf</i>				
2.5 mg BID*	123 [69, 221]	79 [34, 162]	1.8 [1.0, 3.3]	1.2 [0.51, 2.4]
5 mg BID	171 [91, 321]	103 [41, 230]	2.6 [1.4, 4.8]	1.5 [0.61, 3.4]
<i>Treatment of VTE</i>				
2.5 mg BID	67 [30, 153]	32 [11, 90]	1.1 [0.47, 2.4]	0.51 [0.17, 1.4]
5 mg BID	132 [59, 302]	63 [22, 177]	2.1 [0.93, 4.8]	1.0 [0.35, 2.8]
10 mg BID	251 [111, 572]	120 [41, 335]	4.0 [1.8, 9.1]	1.9 [0.65, 5.3]

* Dose adjusted population based on 2 of 3 dose reduction criteria in the ARISTOTLE study.

Pharmacokinetics

Table 14 – Summary of Apixaban Pharmacokinetic Parameters After Repeated Oral Administration of 2.5 mg BID or Single IV Administration of Various Doses in

Humans

	Oral Administration			IV Administration	
	C_{max} (ng/mL)	$t_{1/2}$ (h)	AUC _{0-12hrs} (ng·h/mL)	Clearance (L/h)	Volume of distribution (L)
Healthy Volunteers	73	8.3	530	CL ~ 3.3 CLR ~0.9	V _{ss} ~ 21
Patients	77	N/A	~800	N/A (no IV data)	N/A (no IV data)

N/A = Not available; C_{max} = maximum plasma concentration; $t_{1/2}$ = terminal elimination half-life; AUC₀₋₁₂ = area under the plasma concentration-time curve from time 0 to 12 hours post dose; CL = total systemic clearance; CLR = renal clearance; V_{ss} = volume of distribution at steady state

Absorption

The absolute bioavailability of apixaban is approximately 50% for doses up to 10 mg. Apixaban is rapidly absorbed with maximum concentrations (C_{max}) appearing 3 to 4 hours after tablet intake. Intake with food does not affect apixaban AUC or C_{max} at the 10 mg dose. Apixaban demonstrates linear pharmacokinetics with dose-proportional increases in exposure for oral doses up to 10 mg. At doses ≥ 25 mg apixaban displays dissolution-limited absorption with decreased bioavailability. Apixaban exposure parameters exhibit low to moderate variability reflected by intra-subject and inter-subject variability of ~20% CV (coefficient of variation) and ~30% CV, respectively.

Following oral administration of 10 mg of apixaban as 2 crushed 5 mg tablets suspended in 30 mL of water, exposure was comparable to exposure after oral administration of 2 intact 5 mg tablets. Following oral administration of 10 mg of apixaban as 2 crushed 5 mg tablets mixed with 30 g of applesauce, the C_{max} and AUC were 21% and 16% lower, respectively, when compared to administration of 2 intact 5 mg tablets.

Distribution

Average plasma protein binding in humans is approximately 87% to 93%. The volume of distribution (V_{ss}) is approximately 21 liters.

Metabolism

O-demethylation and hydroxylation at the 3-oxopiperidinyl moiety are the major sites of biotransformation. Apixaban is metabolized mainly via CYP 3A4/5 with minor contributions from CYP 1A2, 2C8, 2C9, 2C19, and 2J2. Unchanged apixaban is the major drug-related component in human plasma with no active circulating metabolites being present. Apixaban is a substrate of transport proteins, P-glycoprotein (P-gp) and breast cancer resistance protein (BCRP).

Excretion

Apixaban has multiple routes of elimination. Of the administered apixaban dose in humans, approximately 25% was recovered as metabolites, with the majority recovered in feces. Renal excretion of apixaban accounts for approximately 27% of total clearance. Additional contributions from biliary and direct intestinal excretion were observed in clinical and nonclinical studies, respectively.

After intravenous administration, apixaban has a systemic clearance of about 3.3 L/h and a half-life of approximately 12 hours.

Special Populations and Conditions

Pediatrics

The efficacy and safety of ELIQUIS in pediatric patients below age 18 years have not yet been established. Health Canada has not authorized an indication for pediatric use. Following the administration of ELIQUIS oral solution, ELIQUIS pharmacokinetics and pharmacodynamics were evaluated in a single-dose study in pediatric subjects at risk for venous or arterial thrombotic disorder. Data from 41 subjects between 28 days to <18 years of age were analyzed using a population pharmacokinetic modeling approach. A 2-compartment population pharmacokinetic model with first-order absorption and elimination described the pharmacokinetics of apixaban in pediatric subjects. The estimated apparent clearance increased with increasing age/body weight and reached adult levels in adolescent subjects (3.93 L/h in subjects 12 years to <18 years of age). Anti-FXa activity exhibited a direct linear relationship with apixaban plasma concentration, comparable to that in adults, with no apparent age-related differences.

Geriatrics

Elderly patients, ie. above 65 years of age, exhibited higher plasma concentrations than younger patients, with mean AUC values being approximately 32% higher. No dose adjustment is required except as described in DOSAGE AND ADMINISTRATION, Geriatrics, *Stroke Reduction in Patients with Atrial Fibrillation*.

Gender

Exposure to apixaban was approximately 18% higher in females than in males. No dose adjustment is required.

Race

The results across Phase I studies showed no discernible difference in apixaban pharmacokinetics between White/Caucasian, Asian and Black/African American subjects. Findings from a population pharmacokinetic analysis in patients who received apixaban were generally consistent with the Phase I results. No dose adjustment is required.

Hepatic Impairment

Patients with severe hepatic impairment or active hepatobiliary disease have not been studied. Apixaban is not recommended in patients with severe hepatic impairment.

In a study comparing 16 subjects with mild and moderate hepatic impairment (classified as Child Pugh A and B, respectively) to 16 healthy control subjects, the single-dose pharmacokinetics and pharmacodynamics of apixaban 5 mg were not altered in subjects with hepatic impairment. Changes in anti-Factor-Xa activity and INR were comparable between subjects with mild to moderate hepatic impairment and healthy subjects. No dose adjustment is required in patients with mild or moderate hepatic impairment. However, given the limited number of subjects studied, caution is advised when using ELIQUIS in this population (see WARNINGS AND PRECAUTIONS, Hepatic Impairment, and DOSAGE AND ADMINISTRATION, Hepatic Impairment).

Renal Impairment

There was an increase in apixaban exposure correlated to decrease in renal function, as assessed via measured creatinine clearance. In individuals with mild (eCrCl 51 – 80 mL/min), moderate (eCrCl 30 – 50 mL/min) and severe (eCrCl 15 - 29 mL/min) renal impairment, apixaban plasma concentrations, measured as AUC, were increased 16, 29, and 44%, respectively, compared to individuals with normal renal function. Renal impairment had no effect on the relationship between apixaban plasma concentration and anti-FXa activity. No dose adjustment is necessary in patients with mild or moderate renal impairment except as described in DOSAGE AND ADMINISTRATION, Renal Impairment, *Stroke Prevention in Patients with Atrial Fibrillation*.

Limited clinical data in patients with severe renal impairment (eCrCl 15 - 29 mL/min) indicate that apixaban plasma concentrations are increased. In patients with atrial fibrillation having eCrCl 25-29 mL/min at study entry, limited data exists in terms of clinical outcomes on stroke and major bleeding (see CLINICAL TRIALS, Stroke Prevention in Atrial Fibrillation, Tables 16, 17, 25 and 26).

There is very limited clinical experience in patients with creatinine clearance < 15 ml/min and no data in patients undergoing dialysis. Therefore, apixaban is not recommended in these patients (see DOSAGE AND ADMINISTRATION, Renal Impairment).

In subjects with end-stage renal disease (ESRD), the AUC of apixaban was increased by 36% when a single dose of apixaban 5 mg was administered immediately after hemodialysis, compared to that seen in subjects with normal renal function. Hemodialysis, started two hours after administration of a single dose of apixaban 5 mg, decreased apixaban AUC by 14% in these ESRD subjects, corresponding to an apixaban dialysis clearance of 18 mL/min.

Body Weight

Compared to apixaban exposure in subjects with body weight of 65 to 85 kg, body weight >120 kg was associated with approximately 20-30% lower exposure, and body weight < 50 kg was associated with approximately 20-30% higher exposure. No dose adjustment is required,

except as described in DOSAGE AND ADMINISTRATION, Body Weight, *Stroke Prevention in Patients with Atrial Fibrillation*.

Post-acute coronary syndrome patients

In a randomized, placebo-controlled trial of 7,392 post-acute coronary syndrome patients with elevated cardiovascular risk, addition of apixaban 5 mg bid to standard antiplatelet treatment caused a significant increased risk of major bleeding events. Major bleeding occurred in 1.1% of placebo-treated patients compared to 2.7% of apixaban-treated patients, without a significant reduction in recurrent ischemic events. All patients were treated with optimised medical treatment post-ACS, including antithrombotic therapy, with about 20 % taking ASA alone and 80% taking a dual antiplatelet regimen, consisting of ASA plus thienopyridine, generally clopidogrel (97.2%).

Acutely ill patients

In a randomized, active-controlled trial of 4,495 acutely ill patients with congestive heart failure, acute respiratory failure, infection or inflammatory diseases and requiring at least 3 days of hospitalisation, an extended course of thromboprophylaxis for 30 days with apixaban 2.5 mg bid was associated with significantly more major bleeding events, i.e., 0.5%, than was a 6- to 14-day course of treatment with enoxaparin 40 mg QD, i.e., 0.2%, while apixaban was not more efficacious.

Cardioversion

In the ARISTOTLE trial, a total of 577 (3.2%) patients underwent cardioversion, including 286, (49.6%) assigned to apixaban, and 291 (50.4%) assigned to warfarin. In the first 90 days following cardioversion, no patient in either group suffered a stroke or systemic embolism (see DOSAGE AND ADMINISTRATION, Cardioversion).

STORAGE AND STABILITY

Store at room temperature (15-30°C).

SPECIAL HANDLING INSTRUCTIONS

None.

DOSAGE FORMS, COMPOSITION AND PACKAGING

Excipients: Tablet core: Anhydrous lactose, microcrystalline cellulose, croscarmellose sodium, sodium lauryl sulfate and magnesium stearate.

Film coat: Lactose monohydrate, hypromellose, titanium dioxide, triacetin, and yellow iron oxide (2.5 mg tablets) or red iron oxide (5 mg tablets).

2.5 mg tablet: Yellow, round tablets debossed with 893 on one side and 2½ on the other side.

5 mg tablet: Pink, oval tablets debossed with 894 on one side and 5 on the other side.

ELIQUIS (apixaban) 2.5 mg tablets are supplied either as blister strips in cartons containing 10, 20, 60 or 100 tablets or in bottles of 14, 60, 180, and 500 tablets.

ELIQUIS (apixaban) 5 mg tablets are supplied either as blister strips in cartons containing 10, 28 or 60 tablets or in bottles of 180 or 500 tablets.

PART II: SCIENTIFIC INFORMATION

PHARMACEUTICAL INFORMATION

Drug Substance

Proper name: apixaban

Chemical name: 1-(4-Methoxyphenyl)-7-oxo-6-[4-(2-oxopiperidin-1-yl)phenyl]-4,5,6,7-tetrahydro-1H-pyrazolo[3,4-c]pyridine-3-carboxamide

Molecular formula and molecular mass: C₂₅H₂₅N₅O₄; 459.5

Structural formula:

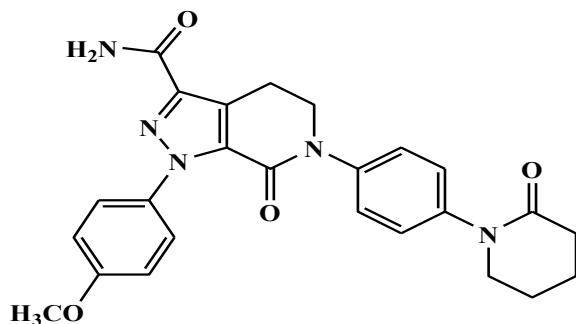

Physicochemical properties:

Apixaban is a white to pale yellow powder. At physiological pH (1.2 - 6.8), apixaban does not ionize; its aqueous solubility across the physiological pH range is ~0.04 mg/mL.

ELIQUIS film-coated tablets are available for oral administration in the strength of 2.5 mg and 5 mg of apixaban with the following inactive ingredients: anhydrous lactose, microcrystalline cellulose, croscarmellose sodium, sodium lauryl sulfate, and magnesium stearate. The film coating contains lactose monohydrate, hypromellose, titanium dioxide, triacetin, yellow iron oxide (2.5 mg tablets) or red iron oxide (5 mg tablets).

CLINICAL TRIALS

Prevention of VTE following Elective Hip or Knee Replacement Surgery

The clinical evidence for the effectiveness of apixaban is derived from the ADVANCE (Clinical Research trial to evaluate Apixaban Dosed orally Versus ANtiCoagulation with injectable Enoxaparin) 1, 2 and 3 clinical trials program. The ADVANCE program was designed to demonstrate the efficacy and safety of apixaban for the prevention of VTE in a broad range of adult patients undergoing elective hip or knee replacement surgery. A total of 11659 patients were randomized in 3 double-blind, multi-national studies. Included in this total were 1866 patients of age 75 or older, 1161 patients with low body weight (≤ 60 kg), 2528 patients with Body Mass Index ≥ 33 kg/m², 602 patients with moderate renal impairment, but only 23 patients with severe renal impairment.

Clinically significant exclusion criteria that were shared by the three ADVANCE studies were: active bleeding; brain, spinal or ophthalmologic major surgery or trauma < 90 days; contraindication to anticoagulant prophylaxis; need for ongoing anticoagulant or antiplatelet treatment; uncontrolled hypertension; active hepatobiliary disease (AST or ALT > 2xULN and/or total bilirubin ≥ 1.5 xULN); clinically significant renal impairment (Cr CL < 30 ml/min); thrombocytopenia; anemia (Hb < 10g/dl); platelet < 100,000/mm³; allergy to heparin; contraindication to (bilateral) venography.

In the ADVANCE-3 study, patients undergoing elective hip replacement surgery, were randomized to receive either apixaban 2.5 mg orally twice daily or enoxaparin 40 mg subcutaneously once daily as recommended in many countries worldwide. The dose of enoxaparin sodium approved for use in thromboprophylaxis in conjunction with elective THR or TKR surgery in Canada is subcutaneous 30 mg twice daily with the first dose to be administered 12 to 24 hours postoperatively. The first dose of apixaban was given 12 to 24 hours post-surgery, whereas enoxaparin was started 9 to 15 hours prior to surgery. Treatment duration was 32-38 days. A total of 5407 patients were randomized in the ADVANCE-3 study.

In patients undergoing elective knee replacement surgery, apixaban 2.5 mg orally twice daily was compared to enoxaparin 40 mg subcutaneously once daily (ADVANCE-2) or enoxaparin 30 mg subcutaneously every 12 hours (ADVANCE-1). In the ADVANCE-2 study, the first dose of apixaban was given 12 to 24 hours post-surgery, whereas enoxaparin was started 9 to 15 hours prior to surgery. In the ADVANCE-1 study, both apixaban and enoxaparin were initiated 12 to 24 hours post-surgery. Treatment duration in both ADVANCE-2 and ADVANCE-1 was 10-14 days. In the ADVANCE-2 and ADVANCE-1 studies, a total of 3057 and 3195 patients were randomized, respectively.

Table 15 – Summary of Patient Demographics

Study #	Trial design	Dosage, route of administration and duration	Study subjects n=number	Mean age (Range)	Gender M/F (%)
CV185035 ADVANCE 3	Randomized, double-blind, parallel group total hip replacement	Apixaban 2.5 mg BID PO Enoxaparin 40 mg QD SC	N=2708	60.9 (19, 92)	47/53
			N=2699	60.6 (19, 93)	46/54
CV185047 ADVANCE 2	Randomized, double-blind, parallel group total knee replacement	Apixaban 2.5 mg BID PO Enoxaparin 40 mg QD SC	N=1528	65.6 (22, 88)	29/71
			N=1529	65.9 (23, 89)	26/74
CV185034 ADVANCE 1	Randomized, double-blind, parallel group total knee replacement	Apixaban 2.5 mg BID PO Enoxaparin 30 mg q12h SC	N=1599	65.9 (26, 93)	38/62
			N=1596	65.7 (33, 89)	38/62

The efficacy data are provided in Table 16. In the ADVANCE-3 study, the rate of the primary endpoint, a composite of total VTE and all cause death (asymptomatic and symptomatic DVT, PE, and all-cause death), was 1.39% for apixaban and 3.86% for enoxaparin, relative risk reduction = 64%, p-value < 0.0001. In the ADVANCE-2 study, the rate of the primary endpoint, total VTE and all-cause death, was 15.06% for apixaban and 24.37% for enoxaparin, relative risk reduction = 38%, p-value < 0.0001. In the ADVANCE-1 study, the rate of the primary endpoint, total VTE and all-cause death, was 8.99% for apixaban and 8.85% for enoxaparin; relative risk 1.02, (95% CI 0.78, 1.32), p>0.05 for non-inferiority.

No clinically relevant differences were observed in the frequency of major bleeding, the composite of major and clinically relevant non-major (CRNM) bleeding and all bleeding in patients treated with apixaban 2.5 mg twice daily or enoxaparin 40 mg once daily and these endpoints were observed at a lower frequency with apixaban 2.5 mg twice daily compared with enoxaparin 30 mg every 12 hours (see ADVERSE REACTIONS, Adverse Drug Reaction Overview, Table 2). All the bleeding criteria included surgical site bleeding.

Table 16 – Efficacy of Apixaban in the Prevention of Venous Thromboembolic Events in Patients Undergoing Elective Hip or Knee Replacement Surgery^a

	ADVANCE-3 (hip)		ADVANCE-2 (knee)		ADVANCE-1 (knee)	
	Apixaban 2.5 mg po bid 35 ± 3 days	Enoxaparin 40 mg sc qd 35 ± 3 days	Apixaban 2.5 mg po bid 12 ± 2 days	Enoxaparin 40 mg sc qd 12 ± 2 days	Apixaban 2.5 mg po bid 12 ± 2 days	Enoxaparin 30 mg sc q12h 12 ± 2 days
Events/N (Event Rate)						
Total VTE/all-cause death (asymptomatic and symptomatic DVT, PE, and all-cause death)						
	27/1949 (1.39%)	74/1917 (3.86%)	147/976 (15.06%)	243/997 (24.37%)	104/1157 (8.99%)	100/1130 (8.85%)
Relative Risk	0.36		0.62		1.02	
95% CI	0.22, 0.54		0.51, 0.74		0.78, 1.32	
P value	< 0.0001		< 0.0001		NS	
All cause death	3/2708 (0.11 %)	1/2699 (0.04 %)	2/1528 (0.13 %)	0/1529 (0.00%)	3/1599 (0.19%)	3/1596 (0.19%)
PE (Fatal or Non-Fatal)	3/2708 (0.11 %)	5/2699 (0.19 %)	4/1528 (0.26%)	0/1529 (0.00%)	16/1599 (1.00 %)	7/1596 (0.44 %)
Symptomatic DVT	1/2708 (0.04%)	5/2699 (0.19%)	3/1528 (0.20%)	7/1529 (0.46%)	3/1599 (0.19%)	7/1596 (0.44%)
Proximal DVT^b	7/2196 (0.32 %)	20/2190 (0.91 %)	9/1192 (0.76%)	26/1199 (2.17%)	9/1254 (0.72 %)	11/1207 (0.91 %)
Distal DVT^b	20/1951 (1.03 %)	57/1908 (2.99 %)	142/978 (14.52%)	239/1000 (23.90%)	83/1146 (7.24 %)	91/1133 (8.03 %)

VTE: Venous Thromboembolic Events; DVT: Deep Vein Thrombosis; PE: Pulmonary Embolism; NS: not significant

^a Events associated with each endpoint were counted once per subject but subjects may have contributed events to multiple endpoints.

^b Includes symptomatic and asymptomatic DVT.

Stroke Prevention in Patients with Atrial Fibrillation

The clinical program was designed to demonstrate the efficacy and safety of apixaban for the prevention of stroke and systemic embolism in patients suitable for VKA, as in the ARISTOTLE trial, and in patients unsuitable for VKA in the AVERROES trial. Both studies were active-controlled (against warfarin in ARISTOTLE, and against aspirin in AVERROES), randomized, double-blind, parallel-arm, multi-national trials in patients with persistent, paroxysmal, or permanent atrial fibrillation (AF) or atrial flutter, and one or more of the following additional risk factors:

- prior stroke or transient ischemic attack (TIA) (also prior systemic embolism in ARISTOTLE)
- age ≥75 years
- arterial hypertension requiring treatment

- diabetes mellitus
- heart failure \geq New York Heart Association Class II
- decreased left ventricular ejection fraction (LVEF)
- documented peripheral arterial disease (AVERROES only)

Patients with prosthetic heart valves, or those with hemodynamically significant rheumatic heart disease, especially mitral stenosis, were excluded from both the ARISTOTLE and AVERROES trials, and thus were not evaluated. These trial results do not apply to these patients, with or without atrial fibrillation (see WARNINGS AND PRECAUTIONS, Cardiovascular, Patients with Valvular Disease).

Table 17 – Study Demographics and Trial Design for the ARISTOTLE and AVERROES clinical trials

Study	ARISTOTLE	AVERROES
Trial design	Warfarin-controlled, randomized, double-blind, parallel arm, multi-national	Aspirin-controlled, randomized, double-blind, parallel arm, multi-national
Dosage, route of administration and duration	Apixaban 5 mg BID PO (2.5 mg BID in selected patients: 4.7%) Warfarin: Target INR 2.0-3.0	Apixaban 5 mg BID PO (2.5 mg BID in selected patients: 6.4%) ASA 81 to 324 mg QD PO 81mg (64.3%) 162mg (26.2%)
Randomized Subjects	18,201	5,598
Mean Age	69.1	69.9
≥ 65 years	69.9%	69.3%
≥ 75 years	31.2%	33.8%
Gender		
Male	64.7%	58.5%
Female	35.3%	41.5%
Race		
White/Caucasian	82.6%	78.6%
Asian	14.5%	19.4%
Black/African American	1.2%	0.6%
Prior stroke or TIA	18.6%	13.6%
Hypertension	87.4%	86.4%
Diabetes	25.0%	19.6%
Heart failure	35.4% (LVEF ≤40%)	33.7% (LVEF ≤35%)
Valvular Disease (not meeting exclusion criteria) *	17.8%	22.7%
Mean CHADS₂ Score	2.1	2.0
CHADS ₂ ≤1	34.0%	38.3%
CHADS ₂ =2	35.8%	35.2%
CHADS ₂ ≥ 3	30.2%	26.5%

*Patients with prosthetic heart valves, or those with hemodynamically significant rheumatic heart disease, especially mitral stenosis, were excluded from both the ARISTOTLE and AVERROES trials

Study Results

The ARISTOTLE Study

Patients were randomized to treatment with apixaban 5 mg orally twice daily (apixaban 2.5 mg twice daily in selected patients) or dose-adjusted warfarin (INR 2.0-3.0). The apixaban 2.5 mg twice daily dose was assigned to patients with at least two (2) of the following characteristics: age ≥ 80 years, body weight ≤ 60 kg, or serum creatinine ≥ 133 micromole/L (1.5mg/dL). Overall, 43% were VKA naive, defined as not having previously received VKA, or having received ≤ 30 consecutive days of treatment with warfarin or another VKA.

Patients were treated for a median of 90 weeks for apixaban and 88 weeks for warfarin.

Coronary artery disease was present in 33% of patients at randomisation.

Patients with an eCrCl < 25 mL/min at study entry were excluded from this trial.

The median time in therapeutic range (TTR) for subjects randomized to warfarin, excluding the first 7 days of the study and excluding warfarin interruptions, was 66.0%.

The primary objective of the study was to determine if apixaban 5 mg twice daily (or 2.5 mg twice daily in selected patients) was non-inferior to warfarin for the prevention of total stroke (ischemic, hemorrhagic, or unspecified) or systemic embolism (SE).

The key study outcomes were pre-specified and tested in a sequential, hierarchical manner to preserve overall type 1 error (false-positive) at $\leq 5\%$. Apixaban was tested compared to warfarin for: (1) non-inferiority on the composite endpoint of stroke and systemic embolism, (2) superiority on the composite endpoint of stroke and systemic embolism, (3) superiority on major bleeding, and (4) superiority on all-cause death.

The results of the key efficacy outcomes are presented below in Table 18 and Figure 1.

To control the overall type I error, the pre-specified, hierarchical sequential testing approach was developed and finalized prior to the interim analysis and performed on the study's main endpoints. The intention-to-treat (ITT) population was used for efficacy outcome testing, the on-treatment population for safety outcomes. Testing demonstrated non-inferiority of apixaban to warfarin on the composite of stroke and SE, ($p < 0.0001$). As non-inferiority was met, ELIQUIS was tested for superiority on the composite of stroke and SE, with superiority over warfarin demonstrated (HR 0.79, 95% CI 0.66 to 0.95, $p = 0.01$).

Table 18– Key Efficacy Outcomes in the ARISTOTLE Study**

	Apixaban N=9120 n (%/yr)	Warfarin N=9081 n (%/yr)	Hazard Ratio (Apixaban vs. Warfarin) (95% CI)	P-Value, (superiority)
Stroke or systemic embolism*	212 (1.27)	265 (1.60)	0.79 (0.66, 0.95)	0.0114
Stroke				
Ischemic or unspecified	162 (0.97)	175 (1.05)	0.92 (0.74, 1.13)	
Hemorrhagic	40 (0.24)	78 (0.47)	0.51 (0.35, 0.75)	
Systemic embolism	15 (0.09)	17 (0.10)	0.87 (0.44, 1.75)	
All-cause death*†	603 (3.52)	669 (3.94)	0.89 (0.80, 1.00)	0.047

* Assessed by sequential testing strategy for superiority designed to control the overall type I error in the trial.

** Intention-To-Treat analyses

† Secondary endpoint

Events for each endpoint were counted once per subject but subjects may have contributed events to more than one endpoint.

The rate of acute myocardial infarction was 0.53%/year in the apixaban and 0.61% in the warfarin treatment groups.

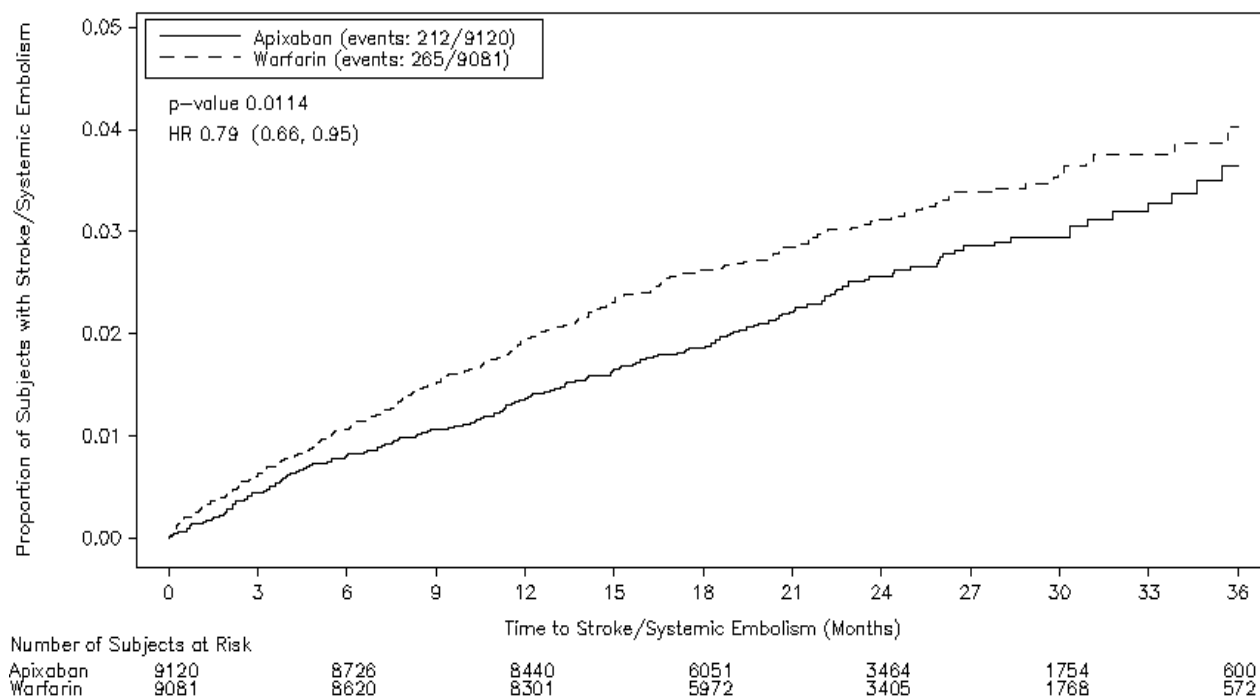

Figure 1 - Kaplan-Meier Curve Estimate of Time to Occurrence of First Stroke or Systemic Embolism in the ARISTOTLE Study

The incidence of clinically important bleeding is given in Table 3.

The event rates for efficacy and safety (bleeding) outcomes, stratified by age, are presented in Table 19 and Table 20, respectively.

Table 19 – Efficacy Outcomes by Age Groups in the ARISTOTLE Trial - All Randomized Patients

	Apixaban		Warfarin		Apixaban vs Warfarin	
	n/N	Event rate (%/yr)	n/N	Event rate (%/yr)	Hazard Ratio (95% CI)	P-value
Adjudicated Stroke or Systemic Embolism (Primary Efficacy Outcome)						
All Patients	212/9120	1.27	265/9081	1.60	0.79 (0.66, 0.95)	0.0114
< 65 years	51/2731	1.00	44/2740	0.86	1.16 (0.77, 1.73)	-
≥ 65 to <75 years	82/3539	1.25	112/3513	1.73	0.72 (0.54, 0.96)	-
≥ 75 years	79/2850	1.56	109/2828	2.19	0.71 (0.53, 0.95)	-
≥ 80 years	33/1225	1.53	40/1211	1.90	0.81 (0.51, 1.29)	-
≥ 85 years	6/322	1.14	18/345	3.25	0.35 (0.14, 0.89)	-
Any Stroke						
All Patients	199/9120	1.19	250/9081	1.51	0.79 (0.65, 0.95)	0.0122
< 65 years	49/2731	0.96	40/2740	0.78	1.22 (0.80, 1.85)	-
≥ 65 to <75 years	74/3539	1.13	109/3513	1.69	0.67 (0.50, 0.90)	-
≥ 75 years	76/2850	1.50	101/2828	2.03	0.74 (0.55, 1.00)	-
≥ 80 years	33/1225	1.53	37/1211	1.76	0.88 (0.55, 1.40)	-
Ischemic or Unspecified Stroke						
All Patients	162/9120	0.97	175/9081	1.05	0.92 (0.74, 1.13)	0.4220
< 65 years	38/2731	0.74	27/2740	0.52	1.40 (0.86, 2.30)	-
≥ 65 to <75 years	64/3539	0.97	79/3513	1.22	0.80 (0.58, 1.12)	-
≥ 75 years	60/2850	1.18	69/2828	1.38	0.86 (0.61, 1.21)	-
≥ 80 years	26/1225	1.21	27/1211	1.28	0.94 (0.55, 1.61)	-
Hemorrhagic Stroke						
All Patients	40/9120	0.24	78/9081	0.47	0.51 (0.35, 0.75)	0.0006
< 65 years	13/2731	0.25	13/2740	0.25	0.99 (0.46, 2.15)	-
≥ 65 to <75 years	10/3539	0.15	33/3513	0.51	0.30 (0.15, 0.61)	-
≥ 75 years	17/2850	0.33	32/2828	0.64	0.53	-

Table 19 – Efficacy Outcomes by Age Groups in the ARISTOTLE Trial - All Randomized Patients

	Apixaban		Warfarin		Apixaban vs Warfarin	
	n/N	Event rate (%/yr)	n/N	Event rate (%/yr)	Hazard Ratio (95% CI)	P-value
					(0.29, 0.95)	
≥ 80 years	7/1225	0.32	10/1211	0.47	0.71 (0.27, 1.86)	-
Cardiovascular Death						
All Patients	308/9120	1.80	344/9081	2.02	0.89 (0.76, 1.04)	0.1384
< 65 years	87/2731	1.67	83/2740	1.58	1.04 (0.77, 1.41)	-
≥ 65 to <75 years	86/3539	1.28	112/3513	1.69	0.76 (0.57, 1.01)	-
≥ 75 years	135/2850	2.60	149/2828	2.91	0.90 (0.71, 1.13)	-
≥ 80 years	64/1225	2.91	84/1211	3.86	0.76 (0.55, 1.05)	-
≥ 85 years	23/322	4.23	43/345	7.59	0.55 (0.33, 0.91)	-

n=number of patients with an event, N=number of patients in each subgroup.

Hazard ratio (95% CI) and p-value are from a Cox proportional hazards model with treatment group as a covariate. Any Stroke includes ischemic stroke, hemorrhagic stroke, ischemic stroke with hemorrhagic conversion, and unspecified stroke.

Table 20 – Bleeding Endpoints by Age Groups in the ARISTOTLE Trial, While on Treatment – Treated Patients

	Apixaban		Warfarin		Apixaban vs. Warfarin	
	n/N	Event rate (%/yr)	n/N	Event rate (%/yr)	Hazard Ratio (95% CI)	P-value
ISTH Major Bleeding (Primary Outcome)						
All Patients	327/9088	2.13	462/9052	3.09	0.69 (0.60,0.80)	<0.0001
< 65 years	56/2723	1.17	72/2732	1.51	0.78 (0.55,1.11)	-
≥ 65 to <75 years	120/3529	1.99	166/3501	2.82	0.71 (0.56,0.89)	-
≥ 75 years	151/2836	3.33	224/2819	5.19	0.64 (0.52,0.79)	-
≥ 80 years	67/1217	3.55	96/1209	5.41	0.66 (0.48,0.90)	-
≥ 85 years	19/322	4.20	30/345	6.47	0.65 (0.36, 1.15)	-
Major and Non-major Clinically Relevant Bleeding Event						
All Patients	613/9088	4.07	877/9052	6.01	0.68 (0.61,0.75)	<0.0001
< 65 years	122/2723	2.59	178/2732	3.82	0.68 (0.54,0.86)	-
≥ 65 to <75 years	234/3529	3.94	320/3501	5.57	0.71	-

					(0.60,0.84)	
≥ 75 years	257/2836	5.81	379/2819	9.04	0.65 (0.55,0.76)	-
≥ 80 years	110/1217	5.98	171/1209	9.93	0.61 (0.48,0.77)	-
Intracranial Hemorrhage						
All Patients	52/9088	0.33	122/9052	0.80	0.42 (0.30,0.58)	<0.0001
< 65 years	15/2723	0.31	17/2732	0.35	0.87 (0.43,1.74)	-
≥ 65 to <75 years	17/3529	0.28	48/3501	0.81	0.35 (0.20,0.60)	-
≥ 75 years	20/2836	0.43	57/2819	1.29	0.34 (0.20,0.57)	-
≥ 80 years	9/1217	0.47	24/1209	1.32	0.36 (0.17,0.77)	-
Fatal Bleeding **						
All Patients	8/9088	0.05	11/9052	0.07	0.71 (0.25, 1.95)	0.6183
< 65 years	1/2723	0.02	2/2732	0.04	0.48 (0.04, 5.30)	-
≥ 65 to <75 years	3/3529	0.05	4/3501	0.07	0.76 (0.17, 3.40)	-
≥ 75 years	4/2836	0.09	5/2819	0.11	0.79 (0.21, 2.93)	-
≥ 80 years	3/1217	0.16	1/1209	0.05	2.86 (0.23, 150.09)	-

Treated patients analysis = adjudicated events while on treatment (up to last dose plus 2 days)

n=number of patients with an event, N=number of patients in each subgroup.

Hazard ratio (95% CI) and p-value are from a Cox proportional hazards model with treatment group as a covariate.

**For fatal bleeding in all patients and in patients ≥ 80 years, risk ratios (95% CI) and p-values are from exact Poisson regression models with treatment group as a covariate.

The event rates for efficacy and safety (bleeding) outcomes, stratified by renal function, are presented in Table 21 and Table 22, respectively.

Table 21 – Efficacy Outcomes by Renal Function* at Baseline in the ARISTOTLE Trial, All Randomized Patients

	Apixaban		Warfarin		Apixaban vs Warfarin	
	n/N	Event rate (%/yr)	n/N	Event rate (%/yr)	Hazard Ratio (95% CI)	P-value
Adjudicated Stroke or Systemic Embolism (Primary Efficacy Outcome)						
All Patients	212/9120	1.27	265/9081	1.60	0.79 (0.66, 0.95)	0.0114
≤ 30 mL/min	6/137	2.79	10/133	5.06	0.55 (0.20, 1.53)	-
>30 – ≤ 50 mL/min	48/1365	2.05	59/1382	2.47	0.83 (0.57, 1.21)	-
> 50 – ≤ 80 mL/min	87/3817	1.24	116/3770	1.69	0.74 (0.56, 0.97)	-

Table 21 – Efficacy Outcomes by Renal Function* at Baseline in the ARISTOTLE Trial, All Randomized Patients

	Apixaban		Warfarin		Apixaban vs Warfarin	
	n/N	Event rate (%/yr)	n/N	Event rate (%/yr)	Hazard Ratio (95% CI)	P-value
> 80 mL/min	70/3761	0.99	79/3757	1.12	0.88 (0.64, 1.21)	-
Any Stroke						
All Patients	199/9120	1.19	250/9081	1.51	0.79 (0.65, 0.95)	0.0122
≤ 30 mL/min	6/137	2.79	10/133	5.06	0.55 (0.20, 1.53)	-
>30 – ≤ 50 mL/min	45/1365	1.92	56/1382	2.34	0.82 (0.55, 1.21)	-
> 50 – ≤ 80 mL/min	81/3817	1.16	108/3770	1.57	0.74 (0.55, 0.98)	-
> 80 mL/min	66/3761	0.93	75/3757	1.06	0.87 (0.63, 1.21)	-
Ischemic or Unspecified Stroke						
All Patients	162/9120	0.97	175/9081	1.05	0.92 (0.74, 1.13)	0.4220
≤ 30 mL/min	6/137	2.79	7/133	3.52	0.78 (0.26, 2.33)	-
>30 – ≤ 50 mL/min	39/1365	1.66	36/1382	1.50	1.11 (0.70, 1.74)	-
> 50 – ≤ 80 mL/min	65/3817	0.93	75/3770	1.09	0.85 (0.61, 1.19)	-
> 80 mL/min	52/3761	0.73	56/3757	0.79	0.92 (0.63, 1.34)	-
Hemorrhagic Stroke						
All Patients	40/9120	0.24	78/9081	0.47	0.51 (0.35, 0.75)	0.0006
≤ 30 mL/min	0/137	0	3/133	1.48	0 §	-
>30 – ≤ 50 mL/min	7/1365	0.29	20/1382	0.83	0.35 (0.15, 0.83)	-
> 50 – ≤ 80 mL/min	16/3817	0.23	36/3770	0.52	0.44 (0.24, 0.79)	-
> 80 mL/min	16/3761	0.22	19/3757	0.27	0.84 (0.43, 1.63)	-
Cardiovascular Death						
All Patients	308/9120	1.80	344/9081	2.02	0.89 (0.76, 1.04)	0.1384
≤ 30 mL/min	15/137	6.85	14/133	6.68	1.03 (0.50, 2.15)	-
>30 – ≤ 50 mL/min	77/1365	3.18	97/1382	3.96	0.80 (0.60, 1.08)	-
> 50 – ≤ 80 mL/min	126/3817	1.76	128/3770	1.81	0.97 (0.76, 1.25)	-
> 80 mL/min	88/3761	1.21	104/3757	1.44	0.84 (0.63, 1.11)	-

n=number of patients with an event, N=number of patients in each subgroup

*patients with eCrCl < 25 mL/min at baseline were excluded from this trial

Hazard ratio (95% CI) and p-value are from a Cox proportional hazards model with treatment group as a covariate.

Any Stroke includes ischemic stroke, hemorrhagic stroke, ischemic stroke with hemorrhagic conversion, and unspecified stroke.

Table 22 – Bleeding Endpoints by Renal Function* at Baseline in the ARISTOTLE Trial, While on Treatment – Treated Patients

	Apixaban		Warfarin		Apixaban vs. Warfarin	
	n/N	Event rate (%/yr)	n/N	Event rate (%/yr)	Hazard Ratio (95% CI)	P-value
ISTH Major Bleeding (Principal Safety Endpoint)						
All Patients	327/9088	2.13	462/9052	3.09	0.69 (0.60,0.80)	<0.0001
≤ 30 mL/min	7/136	3.75	19/132	11.94	0.32 (0.13,0.78)	-
>30 – ≤ 50 mL/min	66/1357	3.16	123/1380	6.01	0.53 (0.39,0.71)	-
> 50 – ≤ 80 mL/min	157/3807	2.45	199/3758	3.21	0.76 (0.62,0.94)	-
> 80 mL/min	96/3750	1.46	119/3746	1.84	0.79 (0.61,1.04)	-
Major and Non-Major Clinically Relevant Bleeding Event						
All Patients	613/9088	4.07	877/9052	6.01	0.68 (0.61,0.75)	<0.0001
≤ 30 mL/min	10/136	5.39	26/132	16.75	0.34 (0.16,0.70)	-
>30 – ≤ 50 mL/min	113/1357	5.52	185/1380	9.17	0.60 (0.48,0.76)	-
> 50 – ≤ 80 mL/min	281/3807	4.47	381/3758	6.31	0.71 (0.61,0.83)	-
> 80 mL/min	206/3750	3.18	282/3746	4.46	0.71 (0.60, 0.86)	-
Intracranial Hemorrhage						
All Patients	52/9088	0.33	122/9052	0.80	0.42 (0.30, 0.58)	<0.0001
≤ 30 mL/min	0/136	0	4/132	2.40	0 §	-
>30 – ≤ 50 mL/min	8/1357	0.38	36/1380	1.71	0.22 (0.10, 0.47)	-
> 50 – ≤ 80 mL/min	25/3807	0.38	52/3758	0.83	0.47 (0.29, 0.75)	-
> 80 mL/min	18/3750	0.27	30/3746	0.46	0.59 (0.33, 1.05)	-
Fatal Bleeding**						
All Patients	8/9088	0.05	11/9052	0.07	0.71 (0.25, 1.95)	0.6183
≤ 30 mL/min	0/136	0	1/132	0.60	0 (0.00, 32.57)	-
>30 – ≤ 50 mL/min	0/1357	0	3/1380	0.14	0 (0.00, 2.38)	-
> 50 – ≤ 80 mL/min	7/3807	0.11	4/3758	0.06	1.70	-

Table 22 – Bleeding Endpoints by Renal Function* at Baseline in the ARISTOTLE Trial, While on Treatment – Treated Patients

	Apixaban		Warfarin		Apixaban vs. Warfarin	
	n/N	Event rate (%/yr)	n/N	Event rate (%/yr)	Hazard Ratio (95% CI)	P-value
					(0.43, 7.94),	
> 80 mL/min	1/3750	0.01	3/3746	0.05	0.32 (0.01, 3.97)	-

Treated patients analysis = adjudicated events while on treatment (up to last dose plus 2 days)

n=number of patients with an event, N=number of patients in each subgroup

*patients with eCrCl < 25 mL/min at baseline were excluded from this trial

Hazard ratio (95% CI) and p-value are from a Cox proportional hazards model with treatment group as a covariate.

**For fatal bleeding analyses, risk ratio (95% CI) and p-value are from an exact Poisson regression model with treatment as a covariate.

The event rates for efficacy and safety (bleeding) outcomes for those patients treated with apixaban 5 mg bid or apixaban 2.5 mg bid are presented in Table 23 and Table 24, respectively. Patients randomised to apixaban received a lower dose of apixaban 2.5 mg bid if they met at least two (2) of the following criteria: age ≥80 years, body weight ≤60 kg, or serum creatinine ≥133 micromole/L (1.5mg/dL).

Table 23 – Efficacy Outcomes by Dose in the ARISTOTLE Trial, All Randomized Patients

	Apixaban		Warfarin		Apixaban vs Warfarin	
	n/N	Event rate (%/yr)	n/N	Event rate (%/yr)	Hazard Ratio (95% CI)	P-value
Adjudicated Stroke or Systemic Embolism (Primary Efficacy Outcome)						
All Patients	212/9120	1.27	265/9081	1.60	0.79 (0.66, 0.95)	0.0114
Apixaban 2.5 mg BID	12/428	1.70	22/403	3.33	0.50 (0.25, 1.02)	-
Apixaban 5 mg BID	200/8692	1.25	243/8678	1.53	0.82 (0.68, 0.98)	-
Any Stroke						
All Patients	199/9120	1.19	250/9081	1.51	0.79 (0.65, 0.95)	0.0122
Apixaban 2.5 mg BID	12/428	1.70	20/403	4.96	0.55 (0.27, 1.13)	-
Apixaban 5 mg BID	187/8692	1.17	230/8678	1.44	0.81 (0.66, 0.98)	-

Ischemic or Unspecified Stroke						
All Patients	162/9120	0.97	175/9081	1.05	0.92 (0.74, 1.13)	0.4220
Apixaban 2.5 mg BID	10/428	1.42	14/403	2.11	0.65 (0.29, 1.47)	-
Apixaban 5 mg BID	152/8692	0.95	161/8678	1.01	0.94 (0.75, 1.17)	-
Hemorrhagic Stroke						
All Patients	40/9120	0.24	78/9081	0.47	0.51 (0.35, 0.75)	0.0006
Apixaban 2.5 mg BID	2/428	0.28	6/403	0.89	0.32 (0.06, 1.57)	-
Apixaban 5 mg BID	38/8692	0.23	72/8678	0.45	0.52 (0.35, 0.78)	-
Cardiovascular Death						
All Patients	308/9120	1.80	344/9081	2.02	0.89 (0.76, 1.04)	0.1384
Apixaban 2.5 mg BID	33/428	4.54	44/403	6.38	0.73 (0.46, 1.15)	-
Apixaban 5 mg BID	275/8692	1.68	300/8678	1.84	0.91 (0.77, 1.07)	-

n=number of patients with an event, N=number of patients in each subgroup.

Hazard ratio (95% CI) and p-value are from a Cox proportional hazards model with treatment group as a covariate. Any Stroke includes ischemic stroke, hemorrhagic stroke, ischemic stroke with hemorrhagic conversion, and unspecified stroke.

Table 24 – Bleeding Endpoints by Dose in the ARISTOTLE Trial, While on Treatment – Treated Patients

	Apixaban		Warfarin		Apixaban vs. Warfarin	
	n/N	Event rate (%/yr)	n/N	Event rate (%/yr)	Hazard Ratio (95% CI)	P-value
ISTH Major Bleeding (Principal Safety Endpoint)						
All Patients	327/9088	2.13	462/9052	3.09	0.69 (0.60,0.80)	<0.0001
Apixaban 2.5 mg BID	20/424	3.29	37/402	6.71	0.50 (0.29,0.86)	-
Apixaban 5 mg BID	307/8664	2.09	425/8650	2.95	0.71 (0.61,0.82)	-
Major and Non-Major Clinically Relevant Bleeding Event						
All Patients	613/9088	4.07	877/9052	6.01	0.68 (0.61,0.75)	<0.0001
Apixaban 2.5 mg BID	30/424	4.97	53/402	9.80	0.52 (0.33,0.81)	-
Apixaban 5 mg BID	583/8664	4.03	824/8650	5.86	0.69 (0.62,0.77)	-

Intracranial Hemorrhage						
All Patients	52/9088	0.33	122/9052	0.80	0.42 (0.30, 0.58)	<0.0001
Apixaban 2.5 mg BID	2/424	0.32	9/402	1.59	0.21 (0.04, 0.96)	-
Apixaban 5 mg BID	50/8664	0.34	113/8650	0.77	0.43 (0.31, 0.61)	-
Fatal Bleeding**						
All Patients	8/9088	0.05	11/9052	0.07	0.71 (0.25, 1.95)	0.6183
Apixaban 2.5 mg BID	0/424	0	1/402	0.18	0 §	-
Apixaban 5 mg BID	8/8664	0.05	10/8650	0.07	0.79 (0.31, 1.99)	-

Treated patients analysis = Adjudicated events while on treatment (up to last dose plus 2 days)

n=number of patients with an event, N=number of patients in each subgroup.

Hazard ratio (95% CI) and p-value are from a Cox proportional hazards model with treatment group as a covariate.

**For fatal bleeding in all patients, risk ratio (95% CI) and p-value are from an exact Poisson regression model with treatment as a covariate and stratified by region and prior VKA status.

The number and percentage of patients who received apixaban by dose are provided below according to degree of renal function at baseline.

Table 25 – Number and percentage of patients who received apixaban by dose according to degree of renal function at baseline in the ARISTOTLE trial

	Apixaban	Warfarin
Apixaban/Placebo 2.5 mg BID, N	424	402
Severe (≤ 30 mL/min), n (%)	88 (20.8)	85 (21.1)
Moderate ($> 30 - \leq 50$ mL/min), n (%)	294 (69.3)	262 (65.2)
Mild ($> 50 - \leq 80$ mL/min), n (%)	42 (9.9)	54 (13.4)
Normal (> 80 mL/min), n (%)	0	1 (0.3)
Not Reported, n (%)	0	0
Apixaban/Placebo 5 mg BID, N	8664	8650
Severe (≤ 30 mL/min), n (%)	48 (0.6)	47 (0.5)
Moderate ($> 30 - \leq 50$ mL/min), n (%)	1063 (12.3)	1118 (12.9)
Mild ($> 50 - \leq 80$ mL/min), n (%)	3765 (43.5)	3704 (42.8)
Normal (> 80 mL/min), n (%)	3750 (43.3)	3745 (43.3)
Not Reported, n (%)	38 (0.4)	36 (0.4)

The denominator to calculate each percentage is the number of subjects treated in each of the apixaban dose groups and treatment group

The AVERROES Study

Patients were randomized to treatment with apixaban 5 mg orally twice daily (or 2.5 mg twice daily in selected patients), or ASA 81 to 324 mg once daily. The selection of an ASA dose of 81, 162, 243, or 324 mg was at the discretion of the investigator with 90.5% of subjects receiving either an 81 mg (64.3%) or 162 mg (26.2%) dose at randomization. The apixaban 2.5 mg twice

daily dose was assigned to patients with at least two (2) of the following characteristics: age ≥ 80 years, body weight ≤ 60 kg, or serum creatinine ≥ 133 micromole/L (1.5mg/dL).

In the study, VKA therapy had been tried but discontinued in 40% of patients prior to enrollment. Common reasons for unsuitability for VKA therapy in the AVERROES study included unable/unlikely to obtain INRs at requested intervals (42.6%), patient refused treatment with VKA (37.4%), CHADS₂ score = 1 and physician did not recommend VKA (21.3%), patient could not be relied on to adhere to VKA medication instruction (15.0%), and difficulty/expected difficulty in contacting patient in case of urgent dose change (11.7%).

Patients were treated for a median of 58 weeks for apixaban, and 59 weeks for ASA.

Patients with an eCrCl < 25 mL/min at study entry were excluded from this trial.

The primary objective of the study was to determine if apixaban 5 mg twice daily (2.5 mg twice daily in selected patients) was superior to ASA (81 to 324 mg QD) in the prevention of stroke or systemic embolism. Assessments of superiority of apixaban versus aspirin were also pre-specified for major vascular events (composite outcome of stroke, systemic embolism, myocardial infarction or vascular death) and for death due to any cause.

The key study outcomes were prespecified and tested in a sequential, hierarchical manner to preserve overall type 1 error (false-positive) at $\leq 5\%$. Apixaban was tested compared to aspirin for: (1) superiority on the composite endpoint of stroke and systemic embolism, (2) superiority on major vascular events (composite outcome of stroke, systemic embolism, myocardial infarction or vascular death), and (3) superiority on all-cause death.

AVERROES was stopped early upon the recommendation of the trial's independent Data Monitoring Committee which found that a pre-defined interim analysis revealed clear evidence of apixaban providing a clinically important reduction in stroke and systemic embolism and acceptable safety profile.

The results of the key efficacy outcomes are presented below in Table 26 and Figure 2.

Table 26 - Key Efficacy Outcomes in the AVERROES Study**

	Apixaban N=2807 n (%/year)	Aspirin N=2791 n (%/year)	Hazard Ratio Apixaban vs. aspirin (95% CI)	P-Value (superiority)
Stroke or systemic embolism*	51 (1.62)	113 (3.63)	0.45 (0.32, 0.62)	< 0.0001
Stroke				
Ischemic or undetermined	43 (1.37)	97 (3.11)	0.44 (0.31, 0.63)	
Hemorrhagic	6 (0.19)	9 (0.28)	0.67 (0.24, 1.88)	
Systemic embolism	2 (0.06)	13 (0.41)	0.15 (0.03, 0.68)	
Stroke, systemic embolism, MI, or vascular death*†	132 (4.21)	197 (6.35)	0.66 (0.53, 0.83)	0.003
Myocardial infarction	24 (0.76)	28 (0.89)	0.86 (0.50, 1.48)	
Vascular Death	84 (2.65)	96 (3.03)	0.87 (0.65, 1.17)	
All-cause death	111 (3.51)	140 (4.42)	0.79 (0.62, 1.02)	0.068

* Assessed by sequential testing strategy designed to control the overall type I error in the trial.

** Intent-To-Treat analyses

†Secondary endpoint

Events for each endpoint were counted once per subject but subjects may have contributed events to more than one endpoint.

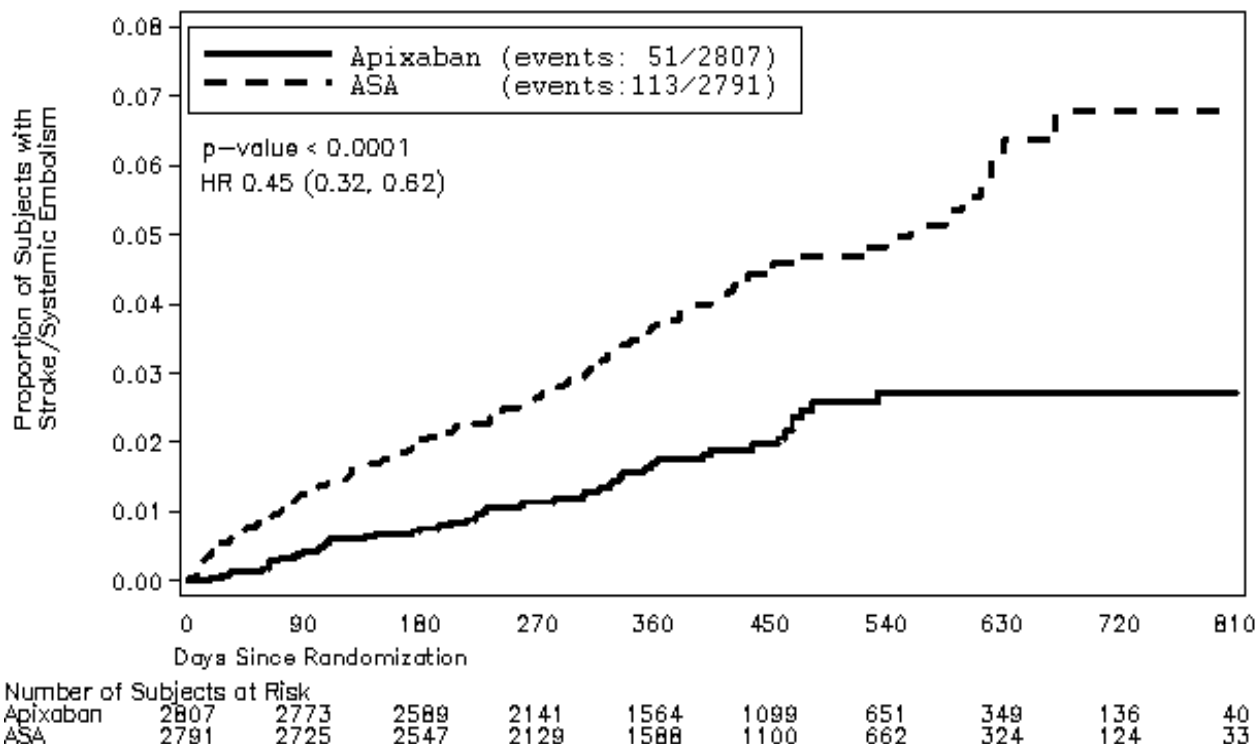

Figure 2 - Kaplan-Meier Curve Estimate of Time to First Occurrence of Stroke or Systemic Embolism in the AVERROES Study

The incidence of clinically important bleeding is given in Table 4.

The event rates for efficacy and safety (bleeding) outcomes, stratified by age, are presented in Table 27 and Table 28, respectively.

Table 27 – Efficacy Outcomes by Age Groups in the AVERROES Trial - All Randomized Patients

	Apixaban		ASA		Apixaban vs ASA	
	n/N	Event rate (%/yr)	n/N	Event rate (%/yr)	Hazard Ratio (95% CI)	P-value
Adjudicated Stroke or Systemic Embolism (Primary Efficacy Outcome)						
All Patients	51/2807	1.62	113/2791	3.63	0.45 (0.32, 0.62)	<0.0001
< 65 years	7/855	0.73	19/865	1.93	0.38 (0.16, 0.89)	-
≥ 65 to <75 years	24/1049	2.02	29/938	2.78	0.73 (0.43, 1.25)	-
≥ 75 years	20/903	2.00	65/988	6.00	0.34 (0.20, 0.56)	-
≥ 80 years	8/455	1.60	38/499	7.06	0.23 (0.11, 0.49)	-
≥ 85 years	2/180	1.02	15/186	7.53	0.14 (0.03, 0.60)	-
Any Stroke						
All Patients	49/2807	1.56	105/2791	3.37	0.46 (0.33, 0.65)	<0.0001
< 65 years	7/855	0.73	17/865	1.72	0.42 (0.17, 1.01)	-
≥ 65 to <75 years	23/1049	1.93	26/938	2.49	0.78 (0.45, 1.37)	-
≥ 75 years	19/903	1.90	62/988	5.70	0.34 (0.20, 0.56)	-
≥ 80 years	7/455	1.40	37/499	6.85	0.21 (0.09, 0.46)	-
Ischemic or Unspecified Stroke						
All Patients	43/2807	1.37	97/2791	3.11	0.44 (0.31, 0.63)	<0.0001
< 65 years	7/855	0.73	15/865	1.52	0.48 (0.19, 1.17)	-
≥ 65 to <75 years	18/1049	1.51	25/938	2.40	0.64 (0.35, 1.16)	-
≥ 75 years	18/903	1.80	57/988	5.23	0.35 (0.20, 0.59)	-
≥ 80 years	6/455	1.20	32/499	5.91	0.20 (0.09, 0.49)	-
Hemorrhagic Stroke						
All Patients	6/2807	0.19	9/2791	0.28	0.67 (0.24, 1.88)	0.4471

Table 27 – Efficacy Outcomes by Age Groups in the AVERROES Trial - All Randomized Patients

	Apixaban		ASA		Apixaban vs ASA	
	n/N	Event rate (%/yr)	n/N	Event rate (%/yr)	Hazard Ratio (95% CI)	P-value
< 65 years	0/855	0.00	2/865	0.20	0 §	-
≥ 65 to <75 years	5/1049	0.42	1/938	0.09	4.44 (0.52, 38.01)	-
≥ 75 years	1/903	0.10	6/988	0.54	0.19 (0.02, 1.56)	-
≥ 80 years	1/455	0.20	6/499	1.08	0.19 (0.02, 1.56)	-
Vascular Death						
All Patients	84/2807	2.65	96/2791	3.03	0.87 (0.65, 1.17)	0.3659
< 65 years	21/855	2.18	10/865	1.00	2.17 (1.02, 4.60)	-
≥ 65 to <75 years	24/1049	2.00	28/938	2.66	0.76 (0.44, 1.31)	-
≥ 75 years	39/903	3.89	58/988	5.19	0.74 (0.49, 1.11)	-
≥ 80 years	29/455	5.80	40/499	7.18	0.78 (0.48, 1.27)	-
≥ 85 years	14/180	7.14	16/186	7.74	0.86 (0.41, 1.79)	-

n=number of patients with an event, N=number of patients in each subgroup.

Hazard ratio (95% CI) and p-value are from a Cox proportional hazards model with treatment group as a covariate. Any Stroke includes ischemic stroke, hemorrhagic stroke, ischemic stroke with hemorrhagic conversion and unspecified stroke

Table 28 – Bleeding Endpoints by Age Groups in the AVERROES Trial, While on Treatment – Treated Patients

	Apixaban		ASA		Apixaban vs ASA	
	n/N	Event rate (%/yr)	n/N	Event rate (%/yr)	Hazard Ratio (95% CI)	P-value
ISTH Major Bleeding (Primary Safety Outcome)						
All Patients	45/2798	1.41	29/2780	0.92	1.54 (0.96, 2.45)	0.0716
< 65 years	8/855	0.81	5/862	0.49	1.67 (0.55, 5.11)	-
≥ 65 to <75 years	11/1044	0.90	6/935	0.56	1.61 (0.60, 4.36)	-
≥ 75 years	26/899	2.65	18/983	1.70	1.57 (0.86, 2.86)	-
≥ 80 years	19/454	3.94	13/498	2.53	1.57 (0.77, 3.17)	-
≥ 85 years	9/179	4.77	6/185	3.31	1.44 (0.51, 4.06)	-
Major and Non-major Clinically Relevant Bleeding Event						
All Patients	140/2798	4.46	101/2780	3.24	1.38	0.0144

Table 28 – Bleeding Endpoints by Age Groups in the AVERROES Trial, While on Treatment – Treated Patients

	Apixaban		ASA		Apixaban vs ASA	
	n/N	Event rate (%/yr)	n/N	Event rate (%/yr)	Hazard Ratio (95% CI)	P-value
					(1.07, 1.78)	
< 65 years	32/855	3.26	26/862	2.58	1.26 (0.75, 2.12)	-
≥ 65 to <75 years	45/1044	3.75	31/935	2.92	1.29 (0.82, 2.04)	-
≥ 75 years	63/899	6.59	44/983	4.20	1.56 (1.06, 2.30)	-
≥ 80 years	38/454	8.05	33/498	6.55	1.24 (0.78, 1.97)	-
Intracranial Hemorrhage**						
All Patients	11/2798	0.34	11/2780	0.35	0.99 (0.39, 2.51)	1.000
< 65 years	0/855	0	2/862	0.20	§	-
≥ 65 to <75 years	5/1044	0.41	1/935	0.09	4.42 (0.52, 37.86)	-
≥ 75 years	6/899	0.61	8/983	0.75	0.81 (0.28, 2.35)	-
≥ 80 years	4/454	0.82	7/498	1.36	0.61 (0.18, 2.07)	-
Fatal Bleeding**						
All Patients	5/2798	0.16	5/2780	0.16	0.99 (0.23, 4.29)	1.000
< 65 years	0/855	0.00	0/862	0.00	§	-
≥ 65 to <75 years	4/1044	0.33	1/935	0.09	3.45 (0.38, 30.84)	-
≥ 75 years	1/899	0.10	4/983	0.38	0.27 (0.03, 2.45)	-
≥ 80 years	1/454	0.21	2/498	0.39	0.54 (0.05, 5.95)	-

Treated patients analysis = adjudicated events while on treatment (up to last dose, plus 2 days for patients who did not enter the open-label extension)

n=number of patients with an event, N=number of patients in each subgroup.

Hazard ratio (95% CI) and p-value are from a Cox proportional hazards model with treatment group as a covariate.

**For fatal bleeding and intracranial bleeding in all patients, risk ratios (95% CI) and p-values are from exact Poisson regression models with treatment as a covariate.

The event rates for efficacy and safety (bleeding) outcomes, stratified by renal function, are presented in Table 29 and Table 30 respectively.

Table 29– Efficacy Outcomes by Renal Function* at Baseline in the AVERROES Trial - All Randomized Patients

	Apixaban		ASA		Apixaban vs ASA	
	n/N	Event rate (%/yr)	n/N	Event rate (%/yr)	Hazard Ratio (95% CI)	P-value
Adjudicated Stroke or Systemic Embolism (Primary Efficacy Outcome)						
All Patients	51/2807	1.62	113/2791	3.63	0.45 (0.32, 0.62)	<0.0001
≤ 30 mL/min	1/55	1.72	4/61	7.07	0.26 (0.03, 2.30)	-
>30 – ≤ 50 mL/min	12/490	2.31	28/478	5.45	0.42 (0.21, 0.83)	-
> 50 – ≤ 80 mL/min	22/1074	1.83	58/1075	4.95	0.37 (0.23, 0.61)	-
> 80 mL/min	12/955	1.09	16/923	1.48	0.74 (0.35, 1.57)	-
Any Stroke						
All Patients	49/2807	1.56	105/2791	3.37	0.46 (0.33, 0.65)	<0.0001
≤ 30 mL/min	1/55	1.72	4/61	7.07	0.26 (0.03, 2.30)	-
>30 – ≤ 50 mL/min	11/490	2.12	26/478	5.05	0.42 (0.21, 0.85)	-
> 50 – ≤ 80 mL/min	22/1074	1.83	54/1075	4.60	0.40 (0.24, 0.66)	-
> 80 mL/min	11/955	1.00	14/923	1.30	0.77 (0.35, 1.70)	-
Ischemic or Unspecified Stroke						
All Patients	43/2807	1.37	97/2791	3.11	0.44 (0.31, 0.63)	<0.0001
≤ 30 mL/min	1/55	1.72	4/61	7.07	0.26 (0.03, 2.30)	-
>30 – ≤ 50 mL/min	11/490	2.12	26/478	5.05	0.42 (0.21, 0.85)	-
> 50 – ≤ 80 mL/min	18/1074	1.50	48/1075	4.08	0.37 (0.21, 0.63)	-
> 80 mL/min	10/955	0.91	13/923	1.20	0.76 (0.33, 1.73)	-
Hemorrhagic Stroke						
All Patients	6/2807	0.19	9/2791	0.28	0.67 (0.24, 1.88)	0.4471
≤ 30 mL/min	0/55	0.00	0/61	0.00	§	-
>30 – ≤ 50 mL/min	0/490	0.00	1/478	0.19	0 §	-
> 50 – ≤ 80 mL/min	4/1074	0.33	6/1075	0.50	0.66 (0.19, 2.35)	-
> 80 mL/min	1/955	0.09	1/923	0.09	0.97 (0.06, 15.53)	-
Vascular Death						
All Patients	84/2807	2.65	96/2791	3.03	0.87 (0.65, 1.17)	0.3659

Table 29– Efficacy Outcomes by Renal Function* at Baseline in the AVERROES Trial - All Randomized Patients

	Apixaban		ASA		Apixaban vs ASA	
	n/N	Event rate (%/yr)	n/N	Event rate (%/yr)	Hazard Ratio (95% CI)	P-value
≤ 30 mL/min	8/55	13.74	8/61	14.02	0.99 (0.37, 2.63)	-
>30 – ≤ 50 mL/min	28/490	5.38	26/478	4.91	1.08 (0.63, 1.84)	-
> 50 – ≤ 80 mL/min	31/1074	2.56	42/1075	3.51	0.73 (0.46, 1.17)	-
> 80 mL/min	11/955	1.00	11/923	1.01	0.98 (0.42, 2.26)	-

n=number of patients with an event, N=number of patients in each subgroup.

*patients with eCrCl < 25 mL/min at baseline were excluded from this trial

Hazard ratio (95% CI) and p-value are from a Cox proportional hazards model with treatment group as a covariate. Any Stroke includes ischemic stroke, hemorrhagic stroke, ischemic stroke with hemorrhagic conversion, and unspecified stroke

Table 30 – Bleeding Endpoints by Renal Function* at Baseline in the AVERROES Trial, While on Treatment – Treated Patients

	Apixaban		ASA		Apixaban vs ASA	
	n/N	Event rate (%/yr)	n/N	Event rate (%/yr)	Hazard Ratio (95% CI)	p-value
ISTH Major Bleeding (Principal Safety Endpoint)						
All Patients	45/2798	1.41	29/2780	0.92	1.54 (0.96, 2.45)	0.0716
≤ 30 mL/min	3/55	5.26	2/61	3.40	1.71 (0.29, 10.22)	-
>30 – ≤ 50 mL/min	17/489	3.35	7/475	1.39	2.43 (1.01, 5.85)	-
> 50 – ≤ 80 mL/min	12/1068	0.98	13/1072	1.09	0.90 (0.41, 1.98)	-
> 80 mL/min	8/953	0.71	4/919	0.36	2.01 (0.60, 6.67)	-
Major and Non-Major Clinically Relevant Bleeding Event						
All Patients	140/2798	4.46	101/2780	3.24	1.38 (1.07, 1.78)	0.0144
≤ 30 mL/min	4/55	7.16	6/61	10.47	0.73 (0.21, 2.59)	-
>30 – ≤ 50 mL/min	35/489	7.02	17/475	3.41	2.05 (1.15, 3.65)	-
> 50 – ≤ 80 mL/min	52/1068	4.34	40/1072	3.40	1.28 (0.85, 1.94)	-
> 80 mL/min	39/953	3.49	30/919	2.74	1.28 (0.79, 2.06)	-
Intracranial Hemorrhage**						
All Patients	11/2798	0.34	11/2780	0.35	0.99 (0.39, 2.51)	1.000
≤ 30 mL/min	1/55	1.75	1/61	1.70	1.16	-

Table 30 – Bleeding Endpoints by Renal Function* at Baseline in the AVERROES Trial, While on Treatment – Treated Patients

	Apixaban		ASA		Apixaban vs ASA	
	n/N	Event rate (%/yr)	n/N	Event rate (%/yr)	Hazard Ratio (95% CI)	p-value
					(0.07, 18.63)	
>30 – ≤ 50 mL/min	3/489	0.59	1/475	0.20	3.07 (0.32, 29.61)	-
> 50 – ≤ 80 mL/min	4/1068	0.33	7/1072	0.59	0.56 (0.16, 1.90)	-
> 80 mL/min	1/953	0.09	0/919	0.00	§	-
Fatal Bleeding**						
All Patients	5/2798	0.16	5/2780	0.16	0.99 (0.23, 4.29)	1.000
≤ 30 mL/min	0/55	0.00	0/61	0.00	§	-
>30 – ≤ 50 mL/min	2/489	0.39	2/475	0.40	1.05 (0.15, 7.46)	-
> 50 – ≤ 80 mL/min	1/1068	0.08	3/1072	0.25	0.33 (0.03, 3.13)	-
> 80 mL/min	1/953	0.09	0/919	0.00	§	-

Treated patients analysis = adjudicated events while on treatment (up to last dose, plus 2 days for patients who did not enter the open-label extension)

n=number of patients with an event, N=number of patients in each subgroup.

*patients with eCrCl < 25 mL/min at baseline were excluded from this trial

Hazard ratio (95% CI) and p-value are from a Cox proportional hazards model with treatment group as a covariate.

**For fatal bleeding and intracranial bleeding in all patients, risk ratios (95% CI) and p-values are from exact Poisson regression models with treatment as a covariate.

The event rates for efficacy and safety (bleeding) outcomes for those patients treated with apixaban 5 mg bid or apixaban 2.5 mg bid are presented in Table 31 and Table 32, respectively. Patients randomised to apixaban received a lower dose of apixaban 2.5 mg bid if they met at least two (2) of the following criteria: age ≥80 years, body weight ≤60 kg, or serum creatinine ≥133 micromole/L (1.5mg/dL).

Table 31 – Efficacy Outcomes by Dose in the AVERROES Trial - All Randomized Patients

	Apixaban		ASA		Apixaban vs ASA	
	n/N	Event rate (%/yr)	n/N	Event rate (%/yr)	Hazard Ratio (95% CI)	P-value
Adjudicated Stroke or Systemic Embolism (Primary Efficacy Outcome)						
All Patients	51/2807	1.62	113/2791	3.63	0.45 (0.32, 0.62)	<0.0001
Apixaban 2.5 mg BID	3/179	1.63	12/182	6.24	0.26 (0.07, 0.93)	-
Apixaban 5 mg BID	48/2628	1.62	101/2609	3.46	0.47 (0.33, 0.66)	-
Any Stroke						

Table 31 – Efficacy Outcomes by Dose in the AVERROES Trial - All Randomized Patients

	Apixaban		ASA		Apixaban vs ASA	
	n/N	Event rate (%/yr)	n/N	Event rate (%/yr)	Hazard Ratio (95% CI)	P-value
All Patients	49/2807	1.56	105/2791	3.37	0.46 (0.33, 0.65)	<0.0001
Apixaban 2.5 mg BID	3/179	1.63	11/182	5.66	0.29 (0.08, 1.04)	-
Apixaban 5 mg BID	46/2628	1.55	94/2609	3.21	0.48 (0.34, 0.69)	-
Ischemic or Unspecified Stroke						
All Patients	43/2807	1.37	97/2791	3.11	0.44 (0.31, 0.63)	<0.0001
Apixaban 2.5 mg BID	3/179	1.63	11/182	5.66	0.29 (0.08, 1.04)	-
Apixaban 5 mg BID	40/2628	1.35	86/2609	2.94	0.46 (0.32, 0.67)	-
Hemorrhagic Stroke						
All Patients	6/2807	0.19	9/2791	0.28	0.67 (0.24, 1.88)	0.4471
Apixaban 2.5 mg BID	0/179	0.00	0/182	0.00	§	-
Apixaban 5 mg BID	6/2628	0.20	9/2609	0.30	0.67 (0.24, 1.88)	-
Vascular Death						
All Patients	84/2807	2.65	96/2791	3.03	0.87 (0.65, 1.17)	0.3659
Apixaban 2.5 mg BID	17/179	9.21	21/182	10.57	0.83 (0.43, 1.59)	-
Apixaban 5 mg BID	67/2628	2.25	75/2609	2.52	0.89 (0.64, 1.24)	-

n=number of patients with an event, N=number of patients in each subgroup.

Hazard ratio (95% CI) and p-value are from a Cox proportional hazards model with treatment group as a covariate. Any Stroke includes ischemic stroke, hemorrhagic stroke, ischemic stroke with hemorrhagic conversion, and unspecified stroke.

Table 32 – Bleeding Endpoints by Dose in the AVERROES Trial, While on Treatment – Treated Patients

	Apixaban		ASA		Apixaban vs ASA	
	n/N	Event rate (%/yr)	n/N	Event rate (%/yr)	Hazard Ratio (95% CI)	p-value
ISTH Major Bleeding (Principal Safety Endpoint)						
All Patients	45/2798	1.41	29/2780	0.92	1.54 (0.96,2.45)	0.0716
Apixaban 2.5 mg BID	8/178	4.48	3/182	1.59	2.82 (0.75,10.62)	-
Apixaban 5 mg BID	37/2620	1.23	26/2598	0.88	1.40	-

Table 32 – Bleeding Endpoints by Dose in the AVERROES Trial, While on Treatment – Treated Patients

	Apixaban		ASA		Apixaban vs ASA	
	n/N	Event rate (%/yr)	n/N	Event rate (%/yr)	Hazard Ratio (95% CI)	p-value
					(0.85, 2.32)	
Major and Non-Major Clinically Relevant Bleeding Event						
All Patients	140/2798	4.46	101/2780	3.24	1.38 (1.07, 1.78)	0.0144
Apixaban 2.5 mg BID	13/178	7.38	7/182	3.73	1.95 (0.78, 4.89)	-
Apixaban 5 mg BID	127/2620	4.29	94/2598	3.21	1.34 (1.02, 1.75)	-
Intracranial Hemorrhage**						
All Patients	11/2798	0.34	11/2780	0.35	0.99 (0.39, 2.51)	1.000
Apixaban 2.5 mg BID	1/178	0.56	1/182	0.53	1.05 (0.07, 16.83)	-
Apixaban 5 mg BID	10/2620	0.33	10/2598	0.34	0.98 (0.41, 2.36)	-
Fatal Bleeding**						
All Patients	5/2798	0.16	5/2780	0.16	0.99 (0.23, 4.29)	1.000
Apixaban 2.5 mg BID	0/178	0.00	0/182	0.00	§	-
Apixaban 5 mg BID	5/2620	0.17	5/2598	0.17	0.98 (0.28, 3.39)	-

Treated patients analysis = adjudicated events while on treatment (up to last dose, plus 2 days for patients who did not enter the open-label extension)

n=number of patients with an event, N=number of patients in each subgroup.

Hazard ratio (95% CI) and p-value are from a Cox proportional hazards model with treatment group as a covariate.

**For fatal bleeding and intracranial bleeding in all patients, risk ratios (95% CI) and p-values are from exact Poisson regression models with treatment as a covariate.

The number and percentage of patients who received apixaban by dose are provided below according to degree of renal function at baseline.

Table 33 – Number and percentage of patients who received apixaban by dose according to degree of renal function at baseline in the AVERROES trial

	Apixaban	ASA
Apixaban/Placebo 2.5 mg BID, N	178	182
Severe (≤ 30 mL/min), n (%)	39 (21.9)	41 (22.5)
Moderate ($> 30 - \leq 50$ mL/min), n (%)	105 (59.0)	112 (61.5)
Mild ($> 50 - \leq 80$ mL/min), n (%)	22 (12.4)	20 (11.0)
Normal (> 80 mL/min), n (%)	1 (0.6)	1 (0.6)
Not Reported, n (%)	11 (6.2)	8 (4.4)
Apixaban/Placebo 5 mg BID, N	2620	2598
Severe (≤ 30 mL/min), n (%)	16 (0.6)	20 (0.8)

Moderate (> 30 - ≤ 50 mL/min), n (%)	384 (14.7)	363 (14.0)
Mild (> 50 - ≤ 80 mL/min), n (%)	1046 (39.9)	1052 (40.5)
Normal (> 80 mL/min), n (%)	952 (36.3)	918 (35.3)
Not Reported, n (%)	222 (8.5)	245 (9.4)

The denominator to calculate each percentage is the number of subjects treated in each of the apixaban dose groups and treatment group

Treatment of DVT and PE and Prevention of recurrent DVT and PE

The clinical program was designed to demonstrate the efficacy and safety of apixaban for the treatment of DVT and PE (AMPLIFY), and extended therapy for the prevention of recurrent DVT and PE following 6 to 12 months of anticoagulant treatment for DVT and/or PE (AMPLIFY-EXT). Both studies were randomized, parallel-group, double-blind multinational trials in patients with symptomatic proximal DVT and/or symptomatic PE. All key safety and efficacy endpoints were adjudicated by an independent blinded committee.

Table 34 – Patient baseline demographic characteristics in the clinical studies

	AMPLIFY	AMPLIFY-EXT
Randomized patients	5395	2482
Mean age	56.9	56.7
≥ 75 years	14.3%	13.3%
Gender (male)	58.7%	57.4%
Body weight ≤ 60 kg	8.5%	6.6%
Race		
White/Caucasian	82.7%	85.3%
Black/African American	3.8%	3.2%
Asian	8.4%	4.8%
Unprovoked events	89.8%	91.7%
Previous episode of PE or proximal VTE	16.2%	n/a*
Immobilization	6.4%	2.8%
Cancer (active)	2.7%	1.7%
Cancer (history)	9.7%	9.2%
Renal function		
Normal eCrCl > 80 mL/min	64.5%	70.1%
50 < eCrCl ≤ 80 mL/min	20.3%	21.6%
30 < eCrCl ≤ 50 mL/min	5.7%	5.3%
eCrCl ≤ 30 mL/min	0.5%	0.2%
History of prothrombotic genotype	2.5%	3.8%

* All patients in AMPLIFY-EXT were required to have a previous episode of PE or proximal VTE in order to enter the study.

AMPLIFY Study: Patients were randomized to treatment with apixaban 10 mg twice daily orally for 7 days followed by apixaban 5 mg twice daily orally for 6 months, or enoxaparin 1 mg/kg twice daily subcutaneously for at least 5 days (until INR \geq 2) and warfarin (target INR range 2.0-3.0) orally for 6 months.

Patients who required thrombectomy, insertion of a caval filter, or use of a fibrinolytic agent, and patients with creatinine clearance <25 mL/min, significant liver disease, or active bleeding were excluded from the study. Patients were allowed to enter the study with or without prior parenteral anticoagulation (up to 48 hours).

For patients randomized to warfarin, the mean percentage of time in therapeutic range (INR 2.0-3.0) was 60.9.

The primary objective of the study was to determine if apixaban was non-inferior to enoxaparin/warfarin therapy in the combined endpoint of adjudicated recurrent symptomatic VTE (non-fatal DVT or non-fatal PE) or VTE-related death over 6 months of therapy.

The key study outcomes were prespecified and tested in a sequential, hierarchical manner to preserve overall type 1 error (false-positive) at $\leq 5\%$. Apixaban was tested compared to enoxaparin/warfarin for: (1) non-inferiority on the composite endpoint of VTE/VTE-related death, (2) superiority on major bleeding, (3) superiority on the composite endpoint of VTE/VTE-related death, and (4) superiority on the composite of major/CRNM bleeding.

In the study, apixaban was shown to be non-inferior to enoxaparin/warfarin in the combined endpoint of adjudicated recurrent symptomatic VTE (non-fatal DVT or non-fatal PE) or VTE-related death (see Table 35).

Table 35 - Efficacy Results in the AMPLIFY Study

	Apixaban N=2609 n(%)	Enoxaparin/Warfarin N=2635 n(%)	Relative Risk (95% CI)
VTE or VTE-related death*	59 (2.3)	71 (2.7)	0.84 (0.60, 1.18)
Non-fatal DVT§	20 (0.7)	33 (1.2)	
Non-fatal PE§	27 (1.0)	23 (0.9)	
VTE-related death§	12 (0.4)	15 (0.6)	
VTE or all-cause death	84 (3.2)	104 (4.0)	0.82 (0.61, 1.08)
All-cause death	41 (1.6)	52 (2.0)	0.79 (0.53, 1.19)
VTE or CV-related death	61 (2.3)	77 (2.9)	0.80 (0.57, 1.11)
VTE, VTE-related death, or major bleeding	73 (2.8)	118 (4.5)	0.62 (0.47, 0.83)

* Non-inferior compared to enoxaparin/warfarin (P-value <0.0001)

§ First event is the first primary event for each subject. Each subject is counted only once.

Figure 3 is a plot of the time from randomization to the occurrence of the first primary efficacy endpoint in the two treatment groups in the AMPLIFY study.

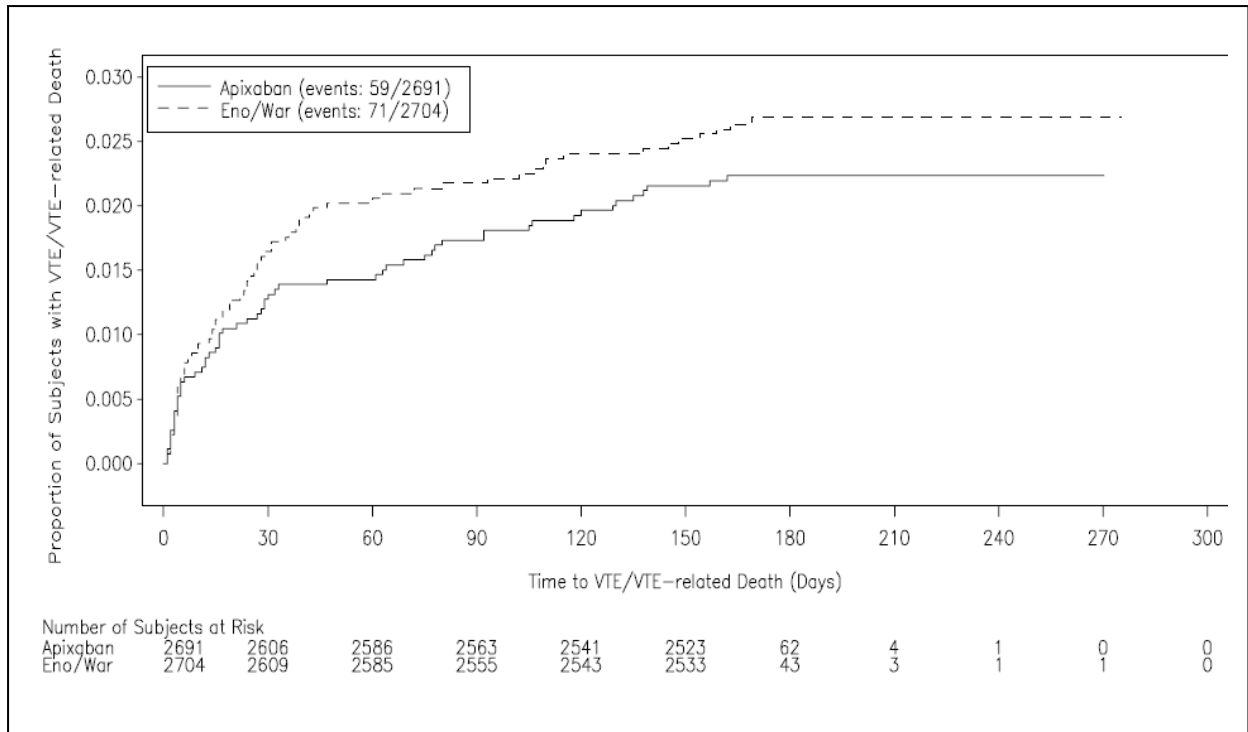

Figure 3 – Kaplan-Meier Estimate of Time to First DVT or PE, or VTE-related Death in the AMPLIFY Study (Intent-to-Treat Population)

Apixaban efficacy in initial treatment of VTE was consistent between patients who were treated for a PE [Relative Risk 0.9, 95% confidence interval (0.5, 1.6)] or DVT [Relative Risk 0.8, 95% confidence interval (0.5, 1.3)]. Efficacy across subgroups, including age, gender, renal function, body mass index (BMI), extent of index of PE, location of DVT thrombus, and prior parenteral heparin use was generally consistent (see Figure 4).

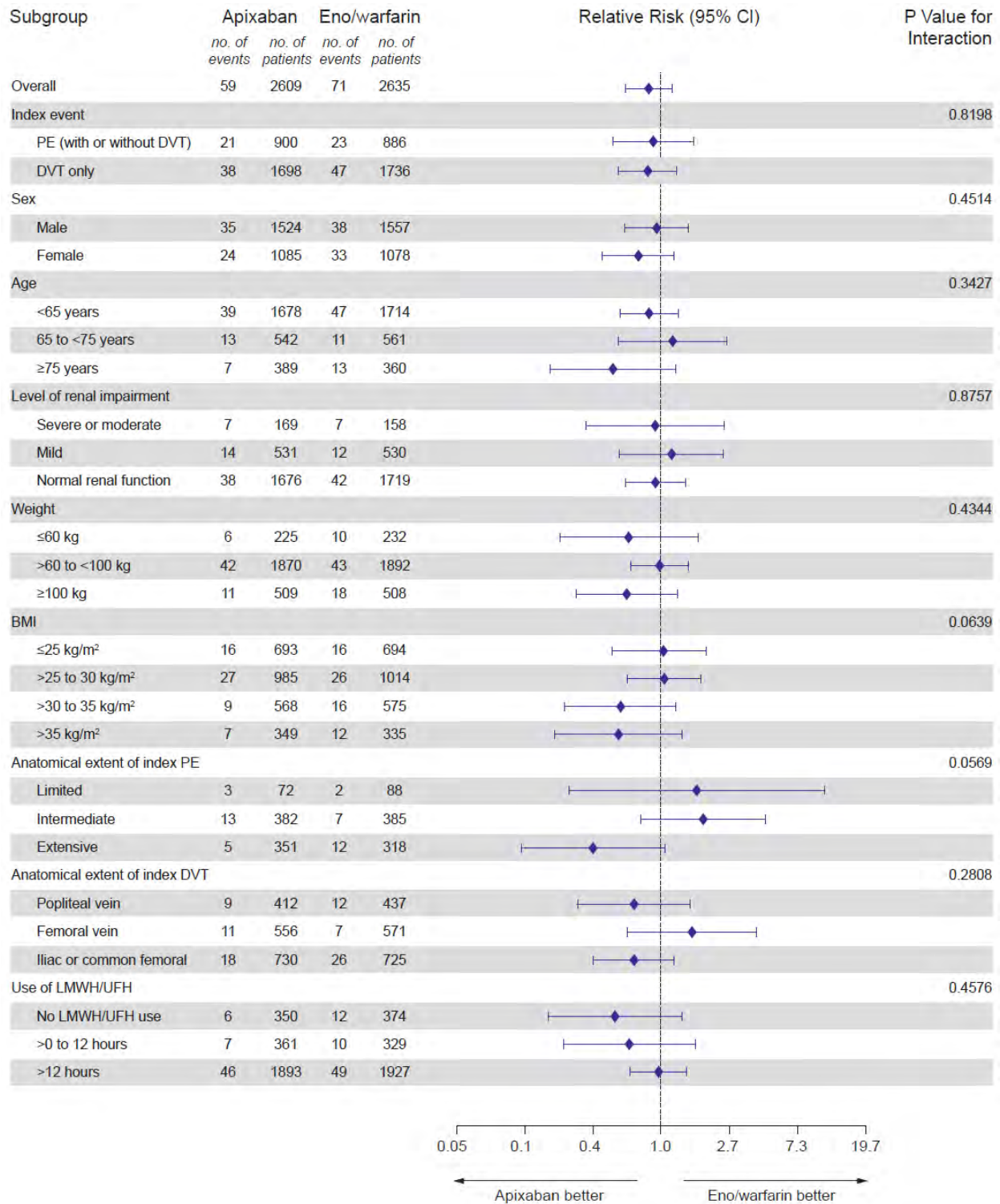

Figure 4 – Recurrent Symptomatic VTE (non-fatal DVT or non-fatal PE) or VTE-related Death Relative Risk by Baseline Characteristics

The primary safety endpoint was major bleeding. In the study, apixaban was statistically superior to enoxaparin/warfarin in the primary safety endpoint [Relative Risk 0.31, 95% confidence interval (0.17, 0.55), P-value <0.0001] (see Table 5).

The adjudicated major bleeding and CRNM bleeding at any anatomical site was generally lower in the apixaban group compared to the enoxaparin/warfarin group. Adjudicated ISTH major gastrointestinal bleeding occurred in 6 (0.2%) apixaban-treated patients and 17 (0.6%) enoxaparin/warfarin-treated patients.

Adjudicated myocardial infarction occurred in 4 (0.1%) apixaban-treated patients and 2 (0.1%) enoxaparin/warfarin-treated patients.

AMPLIFY-EXT Study: AMPLIFY-EXT study evaluated the benefit of continued treatment in patients for whom clinical uncertainty regarding the absolute risk-benefit of extended duration existed. Patients were randomized to treatment with apixaban 2.5 mg twice daily orally, apixaban 5 mg twice daily orally, or placebo for 12 months after completing 6 to 12 months of initial anticoagulant treatment. Approximately one-third of patients participated in the AMPLIFY study prior to enrollment in the AMPLIFY-EXT study.

The primary objective of the study was to determine if apixaban was superior to placebo in the combined endpoint of symptomatic, recurrent VTE (non-fatal DVT or non-fatal PE) or all-cause death.

In the study, apixaban was superior to placebo for the primary efficacy endpoint with a relative risk of 0.24 (95% CI: 0.15 - 0.40) and 0.19 (95% CI: 0.11 - 0.33) for 2.5 mg and 5 mg apixaban, respectively (p<0.0001 for both) (see Table 36).

Table 36 – Efficacy Results in the AMPLIFY-EXT Study

	Apixaban	Apixaban	Placebo (N=829)	Relative Risk (95% CI)		P-value
	2.5 mg (N=840)	5.0 mg (N=813)		Apix 2.5 mg vs. Placebo	Apix 5.0 mg vs. Placebo	
	n (%)					
Recurrent VTE or all-cause death	19 (2.3)	14 (1.7)	77 (9.3)	0.24 (0.15, 0.40)	0.19 (0.11, 0.33)	<0.0001
DVT*	6 (0.7)	7 (0.9)	53 (6.4)			
PE*	7 (0.8)	4 (0.5)	13 (1.6)			

	Apixaban		Placebo (N=829)	Relative Risk (95% CI)		P-value
	2.5 mg (N=840)	5.0 mg (N=813)		Apix 2.5 mg vs. Placebo	Apix 5.0 mg vs. Placebo	
All-cause death	6 (0.7)	3 (0.4)	11 (1.3)			
Recurrent VTE or VTE-related death	14 (1.7)	14 (1.7)	73 (8.8)	0.19 (0.11, 0.33)	0.20 (0.11, 0.34)	<0.0001
Recurrent VTE or CV-related death	14 (1.7)	14 (1.7)	76 (9.2)	0.18 (0.10, 0.32)	0.19 (0.11, 0.33)	<0.0001
Non-fatal DVT [†]	6 (0.7)	8 (1.0)	53 (6.4)	0.11 (0.05, 0.26)	0.15 (0.07, 0.32)	<0.0001
Non-fatal PE [†]	8 (1.0)	4 (0.5)	15 (1.8)	0.51 (0.22, 1.21)	0.27 (0.09, 0.80)	
VTE-related death	2 (0.2)	3 (0.4)	7 (0.8)	0.28 (0.06, 1.37)	0.45 (0.12, 1.71)	
CV-related death	2 (0.2)	3 (0.4)	10 (1.2)	0.20 (0.04, 0.90)	0.31 (0.09, 1.11)	
All-cause death	7 (0.8)	4 (0.5)	14 (1.7)	0.49 (0.20, 1.21)	0.29 (0.10, 0.88)	

* For patients with more than one event contributing to the composite endpoint, only the first event was reported (eg, if a subject experienced both a DVT and then a PE, only the DVT was reported)

† Individual subjects could experience more than one event and be represented in both classifications

Figure 5 is a plot of the time from randomization to the occurrence of the first primary efficacy endpoint event in the three treatment groups in the AMPLIFY-EXT study.

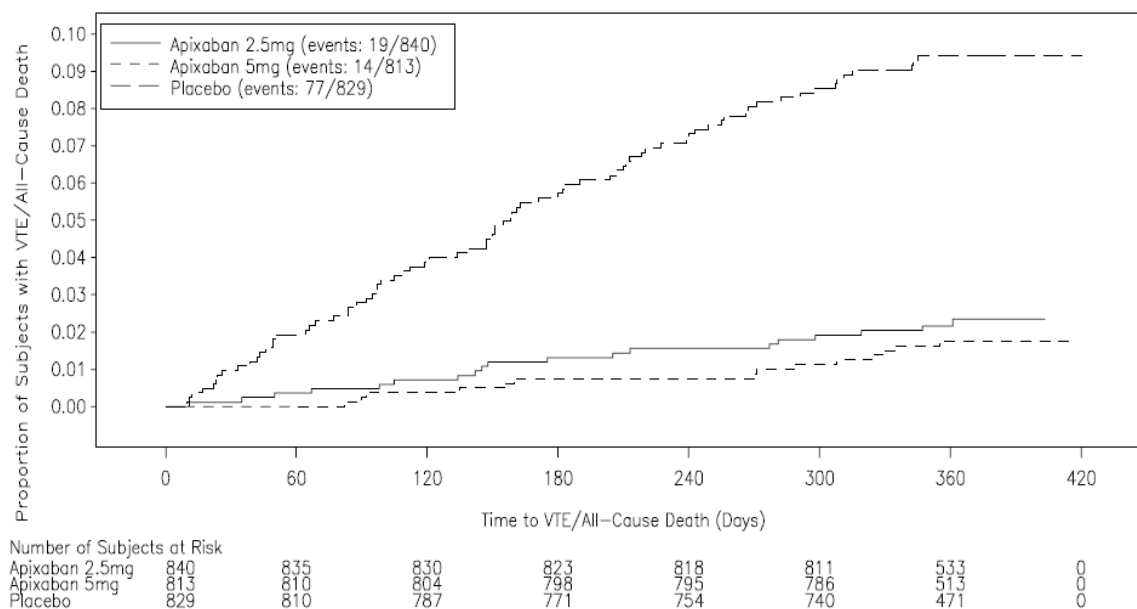

Figure 5 – Kaplan-Meier Estimate of Time to First DVT or PE, or All-cause Death in the AMPLIFY-EXT Study (Intent-to-Treat Population)

Apixaban efficacy for prevention of a recurrence of a VTE was maintained across subgroups, including age, gender, BMI, and renal function.

The primary safety endpoint was major bleeding during the treatment period. In the study, the incidence of major bleeding was similar between the apixaban and placebo groups. There was no statistically significant difference in the incidence of major + CRNM, minor, and all bleeding between the apixaban 2.5 mg twice daily and placebo treatment groups. The frequency of major + CRNM bleeding in the apixaban 5 mg twice daily group was not statistically different from the placebo group. The frequency of CRNM, minor bleeding, and all bleeding in the apixaban 5 mg twice daily group was significantly higher than the placebo group. (See Table 6).

Figure 6 is a plot of the time from randomization to the occurrence of the first major or clinically relevant non-major bleeding event in the three treatment groups in the AMPLIFY-EXT study.

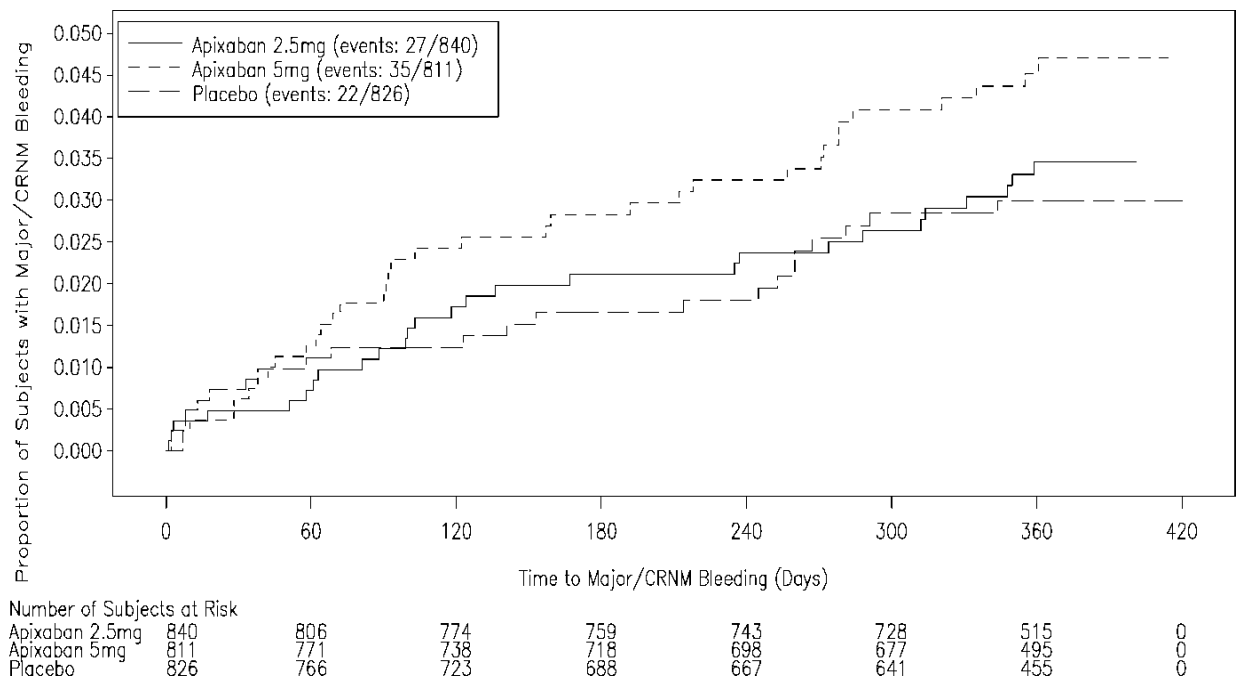

Figure 6 – Kaplan-Meier Estimate of Major/Clinically Relevant Non-major Bleeding During the Treatment Period in the AMPLIFY-EXT Study

ISTH major gastrointestinal bleeding occurred in 1 (0.1%) apixaban-treated patient at the 5 mg twice daily dose, no patients at the 2.5 mg twice daily dose, and 1 (0.1%) placebo-treated patient.

DETAILED PHARMACOLOGY

ELIQUIS (apixaban) is a potent, reversible, direct inhibitor of Factor-Xa (FXa) at the active site with an inhibitory constant (K_i) of 0.08 nM for human FXa and with greater than 30,000-fold selectivity over other human coagulation proteases. It does not require antithrombin III to inhibit FXa. It inhibits free, prothrombinase-bound as well as clot-bound FXa activity and reduces thrombin generation *in vitro*. Apixaban also inhibits FXa from rabbits, rats, and dogs, with K_i of 0.16, 1.4, and 1.8 nM, respectively, which parallels its antithrombotic potency in these species. Apixaban has no direct effects on platelet aggregation, but indirectly inhibits platelet aggregation induced by thrombin derived from the upstream proteases in the blood coagulation cascade. In standard clotting assays, apixaban is more potent in the prolongation of PT than aPTT *ex vivo* in rats, rabbits and dogs.

Apixaban given prophylactically caused dose-dependent antithrombotic activity in multiple species, such as rats, rabbits and dogs, in models of arterial and venous thrombosis, and prevented the growth of a preexisting thrombus. Measurements of apixaban plasma concentrations in these experiments revealed EC_{50} values ranging from approximately 0.1 to 7.57 μ M for inhibition of thrombus formation and maintenance of blood flow. These concentrations tended to be higher in species (rat and dog) for which the FXa affinity of apixaban was lower. Apixaban appeared to have a therapeutic window between the dose that inhibits thrombosis and the dose that increases provoked bleeding, which tended to be model and/or species dependent.

TOXICOLOGY

In chronic dog (≤ 1 year) and rat (≤ 6 months) toxicity studies, the principal findings were reversible pharmacological effects (minimally prolonged PT and aPTT values). At the highest doses tested (600 mg/kg/day in rats, 100 mg/kg/day in dogs), no target organs of toxicity, including liver were identified, there was no overt bleeding or hemorrhage and AUC values were $30\times$ and $114\times$, respectively, the area under the plasma concentration-time curve (AUC) at the recommended human dose (RHD) of 5 mg (2.5 mg BID) for the indication of VTE prevention.

Carcinogenesis

ELIQUIS (apixaban) was not carcinogenic in mice given ≤ 3000 mg/kg/day or rats given ≤ 600 mg/kg/day for 2 years. Apixaban AUC multiples were $\leq 30\times$ the RHD AUC value.

Reproductive Toxicology

Apixaban had no effects on male or female fertility in rats at doses ≤ 600 mg/kg and AUC values $\leq 30\times$ the AUC at the RHD.

Apixaban administered to female rats at ≤ 1000 mg/kg/day during early gestation and throughout the lactation period, produced no findings in offspring (F_1 generation) at 25 mg/kg/day representing an AUC value $9.8\times$ the AUC at the RHD. Effects in the F_1 -generation females were limited to decreased mating and fertility indices at ≥ 200 mg/kg/day at AUC values $\geq 36\times$ the AUC at the RHD. The lower F_1 mating indices have limited clinical relevance because these effects were minimal and occurred only at AUC values well in excess of those at the RHD.

Mutagenesis

Apixaban was not mutagenic in the *in vitro* bacterial reverse mutation (Ames) assay, not clastogenic *in vitro* (cytogenetics assay in Chinese hamster ovary cells) or *in vivo* (1-month *in vivo/in vitro* cytogenetics study in rat peripheral blood lymphocytes), and showed no evidence of genotoxicity in a micronucleus study in rats.

REFERENCES

1. Pinto DJP, Orwat MJ, Koch S, Rossi KA, Alexander RS, Smallwood A, et al. Discovery of 1-(4-methoxyphenyl)-7-oxo-6-(4-(2-oxopiperidin-1-yl)phenyl)-4,5,6,7-tetrahydro-1H-pyrazolo[3,4-c]pyridine-3-carboxamide (apixaban, BMS-562247), a highly potent, selective, efficacious, and orally bioavailable inhibitor of blood coagulation Factor-Xa. *J Med Chem* 2007; 50:5339–56.
2. Lassen MR, Davidson BL, Gallus A, Pineo G, Ansell J, Deitchman D. The efficacy and safety of apixaban, an oral, direct Factor-Xa inhibitor, as thromboprophylaxis in patients following total knee replacement. *J Thromb Haemost*. 2007; 5:2368–75.
3. Wong PC, Crain EJ, Xin B, Wexler RR, Lam PY, Pinto DJ, et al. Apixaban, an oral, direct and highly selective Factor-Xa inhibitor: *in vitro*, antithrombotic and antihemostatic studies. *J Thromb Haemost* 2008; 6(5):820-9.
4. Wong PC, Watson CA, Crain EJ. Arterial antithrombotic and bleeding time effects of apixaban, a direct Factor-Xa inhibitor, in combination with antiplatelet therapy in rabbits. *J Thromb Haemost* 2008; 6:1736-41.
5. Wong P, Crain EJ, Watson CA, Xin B. Favorable therapeutic index of the direct Factor-Xa inhibitors, apixaban and rivaroxaban, compared to the thrombin inhibitor dabigatran in rabbits. *J Thromb Haemost* 2009; 7:1313-20. Epub 2009 Jun 3.
6. Raghavan N, Frost CE, Yu Z, He K, Zhang H, Humphreys WG, et al. Apixaban metabolism and pharmacokinetics following oral administration to humans. *Drug Metab Dispos* 2009; 37(1):74-81.
7. Jiang X, Crain EJ, Luetzgen JM, Schumacher WA, Wong PC. Apixaban, an oral direct Factor-Xa inhibitor, inhibits human clot-bound Factor-Xa activity *in vitro*. *Thromb Haemost* 2009; 101(4):780-2.
8. Zhang D, He K, Raghavan N, Wang L, Mitroka J, Maxwell BD, et al. Comparative metabolism of C-14 Labeled apixaban in mice, rats, rabbits, dogs, and humans. *Drug Metab Dispos* 2009; 37(8):1738-48. Epub 2009 May 6.
9. Lassen MR, Raskob GE, Gallus A, Pineo G, Ansell JE, Chen D, et al. Randomized double-blind comparison of apixaban and enoxaparin for thromboprophylaxis after knee replacement: The ADVANCE-1 Trial. *N Engl J Med* 2009; 361:594-604.
10. Zhang D, He K, Raghavan N, Wang L, Crain EJ, He B, et al. Metabolism, pharmacokinetics and pharmacodynamics of the Factor-Xa inhibitor apixaban in rabbits. *J Thromb Thrombolysis* 2010; 29(1):70-80. Epub 2009 Oct 23.
11. Wang L, Zhang D, Raghavan N, Yao M, Ma L, Frost CA, et al. *In vitro* assessment of metabolic drug-drug interaction potential of apixaban through cytochrome P450 phenotyping, inhibition, and induction studies. *Drug Metab Dispos* 2010; 38(3):448-58. Epub 2009 Nov 25.

12. Lassen MR, Raskob GE, Gallus A, Pineo G, Chen D, Hornick P, and the ADVANCE-2 Investigators. Randomised double-blind comparison of apixaban and once-daily enoxaparin for thromboprophylaxis after knee replacement: the ADVANCE-2 trial. *Lancet* 2010; 375:807-15.
13. Schumacher WA, Bostwick JS, Stewart AB, Steinbacher TE, Xin B, Wong PC. Effect of the direct Factor-Xa inhibitor apixaban in rat models of thrombosis and hemostasis. *J Cardiovasc Pharmacol*. Epub 2010 Mar 6.
14. Lassen MR, et al, for the ADVANCE-3 investigators. Apixaban versus enoxaparin for thromboprophylaxis after hip replacement. *New Engl J Med* 2010; 363:2487-2498.
15. Granger CB, Alexander JH, McMurray JJ, Lopes RD, Hylek EM, Hanna M, et al; ARISTOTLE Committees and Investigators. Apixaban versus warfarin in patients with atrial fibrillation. *N Engl J Med*. 2011 Sep 15;365(11):981-92.
16. Connolly SJ, Eikelboom J, Joyner C, Diener HC, Hart R, Golitsyn S, et al; AVERROES Steering Committee and Investigators. Apixaban in patients with atrial fibrillation. *N Engl J Med*. 2011 Mar 3;364(9):806-17.
17. Agnelli G, Buller HR, Cohen A, et al. Oral apixaban for the treatment of acute venous thromboembolism. *N Engl J Med* 2013; 369:799-808.
18. Agnelli G, Buller HR, Cohen A, et al. Apixaban for extended treatment of venous thromboembolism. *N Engl J Med* 2013, 368: 699-708.

PART III: CONSUMER INFORMATION

**PrELIQUIS®
Apixaban tablets**

This leaflet is Part III of a three-part "Product Monograph" published when ELIQUIS was approved for sale in Canada and is designed specifically for Consumers. This leaflet is a summary and will not tell you everything about ELIQUIS. Contact your doctor or pharmacist if you have any questions about the drug.

ABOUT THIS MEDICATION

What the medication is used for:

ELIQUIS is used in adults for the following conditions:

- **Knee or hip replacement surgery:** To prevent blood clots from forming after knee or hip replacement surgery.
- **Atrial fibrillation:** To reduce the risk of stroke (damage to part of the brain caused by an interruption of its blood supply), and systemic embolism (the sudden blocking of a blood vessel by a blood clot) in people who have a heart condition called *atrial fibrillation* (irregular heart beat).
- **Blood clots:** To treat deep vein thrombosis (blood clots in the veins of your legs) and pulmonary embolism (blood clots in the blood vessels of your lungs) and reduce the risk of them occurring again.

What it does:

ELIQUIS belongs to a group of medicines called anticoagulants. This medicine helps to prevent blood clots from forming by blocking one of the molecules that causes blood clotting (known as Factor-Xa).

When it should not be used:

- you are aware of body lesions at risk of bleeding, including bleeding in the brain (stroke)
- you have certain types of abnormal bleeding such as recent bleeding of a stomach ulcer
- you have active bleeding, especially if you are bleeding excessively
- you have a severe liver disease which leads to increased risk of bleeding (hepatic coagulopathy)
- you are already taking medicines to prevent blood clots, e.g. warfarin (COUMADIN®), heparin, rivaroxaban (XARELTO®), dabigatran (PRADAXA®), unless your physician has decided to switch you to ELIQUIS
- you are also taking prasugrel (EFFIENT®) or ticagrelor (BRILINTA®)
- ELIQUIS should not be used during pregnancy, since its effects on pregnancy and the unborn child are not known
- you are taking oral ketoconazole (a drug used to treat fungus infection)
- while epidural or spinal catheters are in place or within the first five hours after their removal. Your doctor will know what precautionary measures are required. ELIQUIS is not

recommended for patients receiving epidural pain control after surgery

- you have an artificial heart valve
- you are younger than 18 years old
- you are allergic (hypersensitive) to apixaban (active ingredient of ELIQUIS) or any of the other ingredients of ELIQUIS. The ingredients are listed in the "What the nonmedicinal ingredients are:" section of this leaflet

What the medicinal ingredient is:

Apixaban

What the nonmedicinal ingredients are:

Lactose anhydrous, microcrystalline cellulose, croscarmellose sodium, sodium laurylsulfate and magnesium stearate.

Coating ingredients: Lactose monohydrate, hypromellose, titanium dioxide, triacetin, yellow iron oxide (2.5 mg) and red iron oxide (5 mg).

What dosage forms it comes in:

Film-coated tablets in yellow colour, 2.5 mg.

Film-coated tablets in pink colour, 5 mg.

The blister strips are each marked with the following symbols:



(sun: morning)



(moon: evening)

WARNINGS AND PRECAUTIONS

Do not stop taking ELIQUIS without first talking with your doctor. If you stop taking ELIQUIS, blood clots may cause a stroke or other complications. This can be fatal or lead to severe disability.

BEFORE you use ELIQUIS talk to your doctor or pharmacist if you have any of the following:

- an increased risk of bleeding, such as:
 - **bleeding disorders**
 - **an active or a recent ulcer** of your stomach or bowel
 - **infection of the heart** (bacterial endocarditis)
 - **recent bleeding in your brain** (hemorrhagic stroke)
 - **very high blood pressure**, not controlled by medical treatment
 - **a recent operation on your brain, spinal column or eye**
- **severe kidney disease**
- **mild or moderate liver disease**
- **have antiphospholipid syndrome**
- **a tube (catheter) inserted in your back**
- **had an injection into your spinal column within the previous 5 hours, such as an epidural**, for anaesthesia or pain relief.
- **had an operation for a hip fracture** because this medicine has not been studied for this condition.
- you are 75 years of age or older.

ELIQUIS is not recommended in children and adolescents under 18 years of age.

Pregnancy and breast-feeding

Ask your doctor or pharmacist for advice before taking any medicine.

The effects of ELIQUIS on pregnancy and the unborn child are not known. You should not take ELIQUIS if you are pregnant.

Contact your doctor immediately if you become pregnant while taking ELIQUIS.

It is not known if ELIQUIS passes into human breast milk. Ask your doctor or pharmacist for advice before taking ELIQUIS while breast-feeding.

INTERACTIONS WITH THIS MEDICATION

Please tell your doctor or pharmacist if you are taking or have recently taken any other medicines, including medicines obtained without a prescription and herbal supplements.

Some medicines may increase the effects of ELIQUIS and some may decrease its effects. Your doctor will decide, if you should be treated with ELIQUIS when taking these medicines and how closely you should be monitored.

Drugs that may interact with ELIQUIS include:Medicines that may increase the effects of ELIQUIS:

You are at an increased risk for bleeding if you take ELIQUIS with one of these drugs:

- some **medicines for fungal infections** (e.g. ketoconazole, itraconazole, voriconazole and posaconazole)
- some **antiviral medicines for HIV / AIDS** (e.g. ritonavir)
- other **medicines that are used to reduce blood clotting** (e.g. enoxaparin, clopidogrel, prasugrel)
- **anti-inflammatory or pain medicines** (e.g. aspirin or naproxen)
- **medicines for high blood pressure or heart problems** (e.g. diltiazem)
- some **medicines for bacterial infections** (e.g. clarithromycin)
- **antidepressants/anti-anxiety** (SSRIs, SNRIs) (e.g. fluoxetine, citalopram, sertraline, escitalopram, venlafaxine, duloxetine)

Medicines that may reduce the effects of ELIQUIS:

- **medicines to treat tuberculosis or other infections** (e.g. rifampin, rifampicin)
- **medicines to prevent epilepsy or seizures** (e.g. phenytoin, carbamazepine, or phenobarbital)
- **St John's Wort** (a herbal supplement used for depression)

PROPER USE OF THIS MEDICATION**ELIQUIS can be taken with or without food.**

ELIQUIS should be taken regularly, as prescribed, to ensure best results. All temporary discontinuations should be avoided, unless recommended by your physician.

Usual adult dose:*Knee or hip replacement surgery:*

Take one 2.5 mg tablet twice daily, one in the morning and one in the evening. Take the tablet at the same time every day, preferably 12 hours apart. Swallow the tablet whole with a drink of water. **DO NOT** chew the tablet. **DO NOT** stop taking this medication without advice from the doctor.

Always take ELIQUIS exactly as your doctor has told you. You should check with your doctor or pharmacist if you are not sure.

If you have trouble swallowing the tablet(s)

Follow the steps below to crush the ELIQUIS tablet(s). This will help make sure that all of the crushed tablet(s) will be taken.

Steps

- use a mortar and pestle or a similar device to crush the tablet(s)
- transfer the powder to a drinking glass or a small bowl
- when using water:
 - add a small amount of water (30 mL) to the mortar and pestle/device and stir
 - transfer the water to the drinking glass
 - mix the powder with the water and drink right away.
 - rinse the glass with a small amount of water and drink right away
- when using apple sauce:
 - mix the powder with a small amount of apple sauce (30 g) in a small bowl and eat with a spoon right away
 - add a small amount of water (30 mL) to the mortar and pestle/device and stir
 - transfer the water to the bowl and drink right away
 - rinse the bowl and the spoon with a small amount of water and drink right away.

Length of treatment

After major **hip** operation you will usually take the tablets for up to 38 days.

After major **knee** operation you will usually take the tablets for up to 14 days.

Do not stop taking ELIQUIS without talking to your doctor first, because the risk of developing a blood clot could be higher if you stop treatment too early.

Atrial fibrillation (AF):

For most patients with AF, the recommended dose of ELIQUIS is 5 mg taken orally twice daily.

Depending on your age, weight or kidney function, your doctor may prescribe 2.5 mg twice daily.

If you are currently taking warfarin (another oral anticoagulant) or receive anticoagulant treatment given by injection, and your doctor has decided ELIQUIS is appropriate for you, make sure you ask your doctor when and how best to switch and start taking ELIQUIS.

If you have atrial fibrillation and stop taking ELIQUIS without talking to your doctor, you are at risk of suffering from a stroke or other complications due to blood clot formation, which can be fatal or lead to severe disability.

Treatment and prevention of blood clots in the veins of your legs or lungs:

Take 10 mg twice daily (two 5 mg tablets in the morning and two 5 mg tablets in the evening) for 7 days. For treatment after 7 days, take 5 mg twice daily (one 5 mg tablet in the morning and one 5 mg tablet in the evening).

After a minimum of 6 months of treatment, your doctor may prescribe ELIQUIS 2.5 mg twice daily (one 2.5 mg tablet in the morning and one 2.5 mg tablet in the evening).

Length of treatment

This is long-term treatment and you should continue to take ELIQUIS until your doctor says otherwise.

Overdose:

Tell your doctor immediately if you have taken more than the prescribed dose of ELIQUIS

You may have an increased risk of bleeding. If bleeding occurs, surgery or blood transfusions may be required.

If you think you have taken too much ELIQUIS, contact your healthcare professional, hospital emergency department or regional poison control centre immediately, even if there are no symptoms.

Missed Dose:

If you have missed a dose, take the medicine as soon as you remember and continue with your remaining daily dose of ELIQUIS; then carry on taking one tablet, twice a day as normal.

Do not take a double dose to make up for a forgotten tablet of ELIQUIS.

SIDE EFFECTS AND WHAT TO DO ABOUT THEM

Like all medicines, ELIQUIS can cause side effects, although not everybody gets them.

Tell your doctor or pharmacist if you experience any of the following symptoms after taking this medicine.

Like other similar medicines (anticoagulants), ELIQUIS may cause bleedings which could possibly lead to anemia (a low blood cell count which may cause tiredness or paleness). In some cases this bleeding may not be obvious. Nausea (feeling sick) is also a common side effect.

SERIOUS SIDE EFFECTS, HOW OFTEN THEY HAPPEN AND WHAT TO DO ABOUT THEM				
Symptom / effect		Talk with your doctor or pharmacist		Stop taking drug and seek immediate medical help
		Only if severe	In all cases	
Unknown frequency	Allergic Reaction: Rash, hives, swelling of the face, lips, tongue, or throat, difficulty swallowing or breathing			✓
Common	Anemia: fatigue, loss of energy, weakness, shortness of breath		✓	
	Blood in the urine (that stains the urine pink or red)		✓	
	Bruising and swelling		✓	

**SERIOUS SIDE EFFECTS,
HOW OFTEN THEY HAPPEN
AND WHAT TO DO ABOUT THEM**

Symptom / effect		Talk with your doctor or pharmacist		Stop taking drug and seek immediate medical help
		Only if severe	In all cases	
	Bleeding: - in your eyes - from your gums and blood in your spit when coughing - from your rectum - abnormally heavy or long menstrual bleeding		✓	
Uncommon	Bleeding after your operation including bruising and swelling, blood or liquid leaking from the surgical wound/incision		✓	
	Bleeding in your stomach, bowel or blood in the stool		✓	
	Bleeding from your nose		✓	
	Liver Disorder: yellowing of the skin or eyes, dark urine, abdominal pain, nausea, vomiting, loss of appetite		✓	
	Low Blood Pressure: dizziness, fainting, lightheadedness May occur when you go from lying or sitting to standing up	✓		
Rare	Bleeding: - into a muscle		✓	

You should be aware that prescription medicines carry some risks and that all possible risks may not be known at this stage.

Do not be alarmed by this list of possible side effects. You may not experience any of them.

This is not a complete list of side effects. For any unexpected effects while taking ELIQUIS, contact your doctor or pharmacist.

HOW TO STORE IT

Keep at room temperature (15-30°C).

Keep out of the reach and sight of children.

Do not use ELIQUIS after the expiry date which is stated on the carton, the blister, or on the bottle after EXP. The expiry date refers to the last day of that month.

Medicines should not be disposed of via wastewater or household waste. Ask your pharmacist how to dispose of medicines no longer required. These measures will help to protect the environment.

Reporting Side Effects

You can report any suspected side effects associated with the use of health products to Health Canada by:

- Visiting the Web page on Adverse Reaction Reporting (<http://www.hc-sc.gc.ca/dhpmps/medeff/report-declaration/index-eng.php>) for information on how to report online, by mail or by fax; or
- Calling toll-free at 1-866-234-2345.

NOTE: Contact your health professional if you need information about how to manage your side effects. The Canada Vigilance Program does not provide medical advice.

MORE INFORMATION

NOTE: This INFORMATION FOR THE CONSUMER leaflet provides you with the most current information at the time of printing.

The Consumer Information Leaflet plus the full Product Monograph, prepared for health professionals can be found at: www.bms.com/ca and www.pfizer.ca or by contacting Bristol-Myers Squibb Canada Co., at 1-866-463-6267.

This leaflet was prepared by:
Bristol-Myers Squibb Canada Co., Montreal, Quebec H4S 0A4
and Pfizer Canada. ULC Kirkland, Quebec H9J 2M5

ELIQUIS is a registered trademark and Coumadin is a registered trademark of Bristol-Myers Squibb Company used under license by Bristol-Myers Squibb Canada Co.

Other brands listed are trademarks of their respective owners.

Last revised: 07 October 2019

HIGHLIGHTS OF PRESCRIBING INFORMATION

These highlights do not include all the information needed to use ELIQUIS safely and effectively. See full prescribing information for ELIQUIS.

ELIQUIS® (apixaban) tablets, for oral use
Initial U.S. Approval: 2012

WARNING: (A) PREMATURE DISCONTINUATION OF ELIQUIS INCREASES THE RISK OF THROMBOTIC EVENTS

(B) SPINAL/EPIDURAL HEMATOMA

See full prescribing information for complete boxed warning.

(A) PREMATURE DISCONTINUATION OF ELIQUIS INCREASES THE RISK OF THROMBOTIC EVENTS: Premature discontinuation of any oral anticoagulant, including ELIQUIS, increases the risk of thrombotic events. To reduce this risk, consider coverage with another anticoagulant if ELIQUIS is discontinued for a reason other than pathological bleeding or completion of a course of therapy. (2.4, 5.1, 14.1)

(B) SPINAL/EPIDURAL HEMATOMA: Epidural or spinal hematomas may occur in patients treated with ELIQUIS who are receiving neuraxial anesthesia or undergoing spinal puncture. These hematomas may result in long-term or permanent paralysis. Consider these risks when scheduling patients for spinal procedures. (5.3)

RECENT MAJOR CHANGES

Warnings and Precautions, Increased Risk of Thrombosis in Patients with Triple Positive Antiphospholipid Syndrome (5.6) 11/2019

INDICATIONS AND USAGE

ELIQUIS is a factor Xa inhibitor indicated:

- to reduce the risk of stroke and systemic embolism in patients with nonvalvular atrial fibrillation. (1.1)
- for the prophylaxis of deep vein thrombosis (DVT), which may lead to pulmonary embolism (PE), in patients who have undergone hip or knee replacement surgery. (1.2)
- for the treatment of DVT and PE, and for the reduction in the risk of recurrent DVT and PE following initial therapy. (1.3, 1.4, 1.5)

DOSAGE AND ADMINISTRATION

- Reduction of risk of stroke and systemic embolism in nonvalvular atrial fibrillation:
 - The recommended dose is 5 mg orally twice daily. (2.1)
 - In patients with at least 2 of the following characteristics: age greater than or equal to 80 years, body weight less than or equal to 60 kg, or

serum creatinine greater than or equal to 1.5 mg/dL, the recommended dose is 2.5 mg orally twice daily. (2.1)

- Prophylaxis of DVT following hip or knee replacement surgery:
 - The recommended dose is 2.5 mg orally twice daily. (2.1)
- Treatment of DVT and PE:
 - The recommended dose is 10 mg taken orally twice daily for 7 days, followed by 5 mg taken orally twice daily. (2.1)
- Reduction in the risk of recurrent DVT and PE following initial therapy:
 - The recommended dose is 2.5 mg taken orally twice daily. (2.1)

DOSAGE FORMS AND STRENGTHS

- Tablets: 2.5 mg and 5 mg (3)

CONTRAINDICATIONS

- Active pathological bleeding (4)
- Severe hypersensitivity to ELIQUIS (4)

WARNINGS AND PRECAUTIONS

- ELIQUIS can cause serious, potentially fatal, bleeding. Promptly evaluate signs and symptoms of blood loss. An agent to reverse the anti-factor Xa activity of apixaban is available. (5.2)
- Prosthetic heart valves: ELIQUIS use not recommended. (5.4)
- Increased Risk of Thrombosis in Patients with Triple Positive Antiphospholipid Syndrome: ELIQUIS use not recommended. (5.6)

ADVERSE REACTIONS

Most common adverse reactions (>1%) are related to bleeding. (6.1)

To report SUSPECTED ADVERSE REACTIONS, contact Bristol-Myers Squibb at 1-800-721-5072 or FDA at 1-800-FDA-1088 or www.fda.gov/medwatch.

DRUG INTERACTIONS

- Combined P-gp and strong CYP3A4 inhibitors increase blood levels of apixaban. Reduce ELIQUIS dose or avoid coadministration. (2.5, 7.1, 12.3)
- Simultaneous use of combined P-gp and strong CYP3A4 inducers reduces blood levels of apixaban: Avoid concomitant use. (7.2, 12.3)

USE IN SPECIFIC POPULATIONS

- *Pregnancy*: Not recommended. (8.1)
- *Lactation*: Discontinue drug or discontinue nursing. (8.2)
- *Severe Hepatic Impairment*: Not recommended. (8.7, 12.2)

See 17 for PATIENT COUNSELING INFORMATION and Medication Guide.

Revised: 11/2019

FULL PRESCRIBING INFORMATION: CONTENTS*

WARNING: (A) PREMATURE DISCONTINUATION OF ELIQUIS INCREASES THE RISK OF THROMBOTIC EVENTS

(B) SPINAL/EPIDURAL HEMATOMA

1 INDICATIONS AND USAGE

- 1.1 Reduction of Risk of Stroke and Systemic Embolism in Nonvalvular Atrial Fibrillation
- 1.2 Prophylaxis of Deep Vein Thrombosis Following Hip or Knee Replacement Surgery
- 1.3 Treatment of Deep Vein Thrombosis
- 1.4 Treatment of Pulmonary Embolism
- 1.5 Reduction in the Risk of Recurrence of DVT and PE

2 DOSAGE AND ADMINISTRATION

- 2.1 Recommended Dose
- 2.2 Missed Dose
- 2.3 Temporary Interruption for Surgery and Other Interventions
- 2.4 Converting from or to ELIQUIS
- 2.5 Combined P-gp and Strong CYP3A4 Inhibitors
- 2.6 Administration Options

3 DOSAGE FORMS AND STRENGTHS

4 CONTRAINDICATIONS

5 WARNINGS AND PRECAUTIONS

- 5.1 Increased Risk of Thrombotic Events after Premature Discontinuation
- 5.2 Bleeding
- 5.3 Spinal/Epidural Anesthesia or Puncture
- 5.4 Patients with Prosthetic Heart Valves

- 5.5 Acute PE in Hemodynamically Unstable Patients or Patients who Require Thrombolysis or Pulmonary Embolectomy
- 5.6 Increased Risk of Thrombosis in Patients with Triple Positive Antiphospholipid Syndrome

6 ADVERSE REACTIONS

- 6.1 Clinical Trials Experience

7 DRUG INTERACTIONS

- 7.1 Combined P-gp and Strong CYP3A4 Inhibitors
- 7.2 Combined P-gp and Strong CYP3A4 Inducers
- 7.3 Anticoagulants and Antiplatelet Agents

8 USE IN SPECIFIC POPULATIONS

- 8.1 Pregnancy
- 8.2 Lactation
- 8.4 Pediatric Use
- 8.5 Geriatric Use
- 8.6 Renal Impairment
- 8.7 Hepatic Impairment

10 OVERDOSAGE

11 DESCRIPTION

12 CLINICAL PHARMACOLOGY

- 12.1 Mechanism of Action
- 12.2 Pharmacodynamics
- 12.3 Pharmacokinetics

13 NONCLINICAL TOXICOLOGY

- 13.1 Carcinogenesis, Mutagenesis, Impairment of Fertility

14 CLINICAL STUDIES

- 14.1 Reduction of Risk of Stroke and Systemic Embolism in Nonvalvular Atrial Fibrillation
 - 14.2 Prophylaxis of Deep Vein Thrombosis Following Hip or Knee Replacement Surgery
 - 14.3 Treatment of DVT and PE and Reduction in the Risk of Recurrence of DVT and PE
-

16 HOW SUPPLIED/STORAGE AND HANDLING
17 PATIENT COUNSELING INFORMATION

* Sections or subsections omitted from the full prescribing information are not listed.

FULL PRESCRIBING INFORMATION

WARNING: (A) PREMATURE DISCONTINUATION OF ELIQUIS INCREASES THE RISK OF THROMBOTIC EVENTS (B) SPINAL/EPIDURAL HEMATOMA

(A) PREMATURE DISCONTINUATION OF ELIQUIS INCREASES THE RISK OF THROMBOTIC EVENTS

Premature discontinuation of any oral anticoagulant, including ELIQUIS, increases the risk of thrombotic events. If anticoagulation with ELIQUIS is discontinued for a reason other than pathological bleeding or completion of a course of therapy, consider coverage with another anticoagulant [*see Dosage and Administration (2.4), Warnings and Precautions (5.1), and Clinical Studies (14.1)*].

(B) SPINAL/EPIDURAL HEMATOMA

Epidural or spinal hematomas may occur in patients treated with ELIQUIS who are receiving neuraxial anesthesia or undergoing spinal puncture. These hematomas may result in long-term or permanent paralysis. Consider these risks when scheduling patients for spinal procedures. Factors that can increase the risk of developing epidural or spinal hematomas in these patients include:

- use of indwelling epidural catheters
- concomitant use of other drugs that affect hemostasis, such as nonsteroidal anti-inflammatory drugs (NSAIDs), platelet inhibitors, other anticoagulants
- a history of traumatic or repeated epidural or spinal punctures
- a history of spinal deformity or spinal surgery
- optimal timing between the administration of ELIQUIS and neuraxial procedures is not known

[*see Warnings and Precautions (5.3)*]

Monitor patients frequently for signs and symptoms of neurological impairment. If neurological compromise is noted, urgent treatment is necessary [*see Warnings and Precautions (5.3)*].

Consider the benefits and risks before neuraxial intervention in patients anticoagulated or to be anticoagulated [*see Warnings and Precautions (5.3)*].

1 INDICATIONS AND USAGE

1.1 Reduction of Risk of Stroke and Systemic Embolism in Nonvalvular Atrial Fibrillation

ELIQUIS is indicated to reduce the risk of stroke and systemic embolism in patients with nonvalvular atrial fibrillation.

1.2 Prophylaxis of Deep Vein Thrombosis Following Hip or Knee Replacement Surgery

ELIQUIS is indicated for the prophylaxis of deep vein thrombosis (DVT), which may lead to pulmonary embolism (PE), in patients who have undergone hip or knee replacement surgery.

1.3 Treatment of Deep Vein Thrombosis

ELIQUIS is indicated for the treatment of DVT.

1.4 Treatment of Pulmonary Embolism

ELIQUIS is indicated for the treatment of PE.

1.5 Reduction in the Risk of Recurrence of DVT and PE

ELIQUIS is indicated to reduce the risk of recurrent DVT and PE following initial therapy.

2 DOSAGE AND ADMINISTRATION

2.1 Recommended Dose

Reduction of Risk of Stroke and Systemic Embolism in Patients with Nonvalvular Atrial Fibrillation

The recommended dose of ELIQUIS for most patients is 5 mg taken orally twice daily.

The recommended dose of ELIQUIS is 2.5 mg twice daily in patients with at least two of the following characteristics:

- age greater than or equal to 80 years
- body weight less than or equal to 60 kg
- serum creatinine greater than or equal to 1.5 mg/dL

Prophylaxis of Deep Vein Thrombosis Following Hip or Knee Replacement Surgery

The recommended dose of ELIQUIS is 2.5 mg taken orally twice daily. The initial dose should be taken 12 to 24 hours after surgery.

- In patients undergoing hip replacement surgery, the recommended duration of treatment is 35 days.
- In patients undergoing knee replacement surgery, the recommended duration of treatment is 12 days.

Treatment of DVT and PE

The recommended dose of ELIQUIS is 10 mg taken orally twice daily for the first 7 days of therapy. After 7 days, the recommended dose is 5 mg taken orally twice daily.

Reduction in the Risk of Recurrence of DVT and PE

The recommended dose of ELIQUIS is 2.5 mg taken orally twice daily after at least 6 months of treatment for DVT or PE [see *Clinical Studies (14.3)*].

2.2 Missed Dose

If a dose of ELIQUIS is not taken at the scheduled time, the dose should be taken as soon as possible on the same day and twice-daily administration should be resumed. The dose should not be doubled to make up for a missed dose.

2.3 Temporary Interruption for Surgery and Other Interventions

ELIQUIS should be discontinued at least 48 hours prior to elective surgery or invasive procedures with a moderate or high risk of unacceptable or clinically significant bleeding [*see Warnings and Precautions (5.2)*]. ELIQUIS should be discontinued at least 24 hours prior to elective surgery or invasive procedures with a low risk of bleeding or where the bleeding would be non-critical in location and easily controlled. Bridging anticoagulation during the 24 to 48 hours after stopping ELIQUIS and prior to the intervention is not generally required. ELIQUIS should be restarted after the surgical or other procedures as soon as adequate hemostasis has been established.

2.4 Converting from or to ELIQUIS

Switching from warfarin to ELIQUIS: Warfarin should be discontinued and ELIQUIS started when the international normalized ratio (INR) is below 2.0.

Switching from ELIQUIS to warfarin: ELIQUIS affects INR, so that initial INR measurements during the transition to warfarin may not be useful for determining the appropriate dose of warfarin. One approach is to discontinue ELIQUIS and begin both a parenteral anticoagulant and warfarin at the time the next dose of ELIQUIS would have been taken, discontinuing the parenteral anticoagulant when INR reaches an acceptable range.

Switching from ELIQUIS to anticoagulants other than warfarin (oral or parenteral): Discontinue ELIQUIS and begin taking the new anticoagulant other than warfarin at the usual time of the next dose of ELIQUIS.

Switching from anticoagulants other than warfarin (oral or parenteral) to ELIQUIS: Discontinue the anticoagulant other than warfarin and begin taking ELIQUIS at the usual time of the next dose of the anticoagulant other than warfarin.

2.5 Combined P-gp and Strong CYP3A4 Inhibitors

For patients receiving ELIQUIS doses of 5 mg or 10 mg twice daily, reduce the dose by 50% when ELIQUIS is coadministered with drugs that are combined P-glycoprotein (P-gp) and strong cytochrome P450 3A4 (CYP3A4) inhibitors (e.g., ketoconazole, itraconazole, ritonavir) [*see Clinical Pharmacology (12.3)*].

In patients already taking 2.5 mg twice daily, avoid coadministration of ELIQUIS with combined P-gp and strong CYP3A4 inhibitors [*see Drug Interactions (7.1)*].

2.6 Administration Options

For patients who are unable to swallow whole tablets, 5 mg and 2.5 mg ELIQUIS tablets may be crushed and suspended in water, 5% dextrose in water (D5W), or apple juice, or mixed with applesauce and promptly administered orally [*see Clinical Pharmacology (12.3)*]. Alternatively,

ELIQUIS tablets may be crushed and suspended in 60 mL of water or D5W and promptly delivered through a nasogastric tube [*see Clinical Pharmacology (12.3)*].

Crushed ELIQUIS tablets are stable in water, D5W, apple juice, and applesauce for up to 4 hours.

3 DOSAGE FORMS AND STRENGTHS

- 2.5 mg, yellow, round, biconvex, film-coated tablets with “893” debossed on one side and “2½” on the other side.
- 5 mg, pink, oval-shaped, biconvex, film-coated tablets with “894” debossed on one side and “5” on the other side.

4 CONTRAINDICATIONS

ELIQUIS is contraindicated in patients with the following conditions:

- Active pathological bleeding [*see Warnings and Precautions (5.2) and Adverse Reactions (6.1)*]
- Severe hypersensitivity reaction to ELIQUIS (e.g., anaphylactic reactions) [*see Adverse Reactions (6.1)*]

5 WARNINGS AND PRECAUTIONS

5.1 Increased Risk of Thrombotic Events after Premature Discontinuation

Premature discontinuation of any oral anticoagulant, including ELIQUIS, in the absence of adequate alternative anticoagulation increases the risk of thrombotic events. An increased rate of stroke was observed during the transition from ELIQUIS to warfarin in clinical trials in atrial fibrillation patients. If ELIQUIS is discontinued for a reason other than pathological bleeding or completion of a course of therapy, consider coverage with another anticoagulant [*see Dosage and Administration (2.4) and Clinical Studies (14.1)*].

5.2 Bleeding

ELIQUIS increases the risk of bleeding and can cause serious, potentially fatal, bleeding [*see Dosage and Administration (2.1) and Adverse Reactions (6.1)*].

Concomitant use of drugs affecting hemostasis increases the risk of bleeding. These include aspirin and other antiplatelet agents, other anticoagulants, heparin, thrombolytic agents, selective serotonin reuptake inhibitors, serotonin norepinephrine reuptake inhibitors, and nonsteroidal anti-inflammatory drugs (NSAIDs) [*see Drug Interactions (7.3)*].

Advise patients of signs and symptoms of blood loss and to report them immediately or go to an emergency room. Discontinue ELIQUIS in patients with active pathological hemorrhage.

Reversal of Anticoagulant Effect

An agent to reverse the anti-factor Xa activity of apixaban is available. The pharmacodynamic effect of ELIQUIS can be expected to persist for at least 24 hours after the last dose, i.e., for about two drug half-lives. Prothrombin complex concentrate (PCC), activated prothrombin complex concentrate or recombinant factor VIIa may be considered, but have not been evaluated in clinical

studies [see *Clinical Pharmacology (12.2)*]. When PCCs are used, monitoring for the anticoagulation effect of apixaban using a clotting test (PT, INR, or aPTT) or anti-factor Xa (FXa) activity is not useful and is not recommended. Activated oral charcoal reduces absorption of apixaban, thereby lowering apixaban plasma concentration [see *Overdosage (10)*].

Hemodialysis does not appear to have a substantial impact on apixaban exposure [see *Clinical Pharmacology (12.3)*]. Protamine sulfate and vitamin K are not expected to affect the anticoagulant activity of apixaban. There is no experience with antifibrinolytic agents (tranexamic acid, aminocaproic acid) in individuals receiving apixaban. There is no experience with systemic hemostatics (desmopressin) in individuals receiving ELIQUIS, and they are not expected to be effective as a reversal agent.

5.3 Spinal/Epidural Anesthesia or Puncture

When neuraxial anesthesia (spinal/epidural anesthesia) or spinal/epidural puncture is employed, patients treated with antithrombotic agents for prevention of thromboembolic complications are at risk of developing an epidural or spinal hematoma which can result in long-term or permanent paralysis.

The risk of these events may be increased by the postoperative use of indwelling epidural catheters or the concomitant use of medicinal products affecting hemostasis. Indwelling epidural or intrathecal catheters should not be removed earlier than 24 hours after the last administration of ELIQUIS. The next dose of ELIQUIS should not be administered earlier than 5 hours after the removal of the catheter. The risk may also be increased by traumatic or repeated epidural or spinal puncture. If traumatic puncture occurs, delay the administration of ELIQUIS for 48 hours.

Monitor patients frequently for signs and symptoms of neurological impairment (e.g., numbness or weakness of the legs, or bowel or bladder dysfunction). If neurological compromise is noted, urgent diagnosis and treatment is necessary. Prior to neuraxial intervention the physician should consider the potential benefit versus the risk in anticoagulated patients or in patients to be anticoagulated for thromboprophylaxis.

5.4 Patients with Prosthetic Heart Valves

The safety and efficacy of ELIQUIS have not been studied in patients with prosthetic heart valves. Therefore, use of ELIQUIS is not recommended in these patients.

5.5 Acute PE in Hemodynamically Unstable Patients or Patients who Require Thrombolysis or Pulmonary Embolectomy

Initiation of ELIQUIS is not recommended as an alternative to unfractionated heparin for the initial treatment of patients with PE who present with hemodynamic instability or who may receive thrombolysis or pulmonary embolectomy.

5.6 Increased Risk of Thrombosis in Patients with Triple Positive Antiphospholipid Syndrome

Direct-acting oral anticoagulants (DOACs), including ELIQUIS, are not recommended for use in patients with triple-positive antiphospholipid syndrome (APS). For patients with APS (especially

those who are triple positive [positive for lupus anticoagulant, anticardiolipin, and anti-beta 2-glycoprotein I antibodies]), treatment with DOACs has been associated with increased rates of recurrent thrombotic events compared with vitamin K antagonist therapy.

6 ADVERSE REACTIONS

The following clinically significant adverse reactions are discussed in greater detail in other sections of the prescribing information.

- Increased Risk of Thrombotic Events After Premature Discontinuation [*see Warnings and Precautions (5.1)*]
- Bleeding [*see Warnings and Precautions (5.2)*]
- Spinal/Epidural Anesthesia or Puncture [*see Warnings and Precautions (5.3)*]

6.1 Clinical Trials Experience

Because clinical trials are conducted under widely varying conditions, adverse reaction rates observed in the clinical trials of a drug cannot be directly compared to rates in the clinical trials of another drug and may not reflect the rates observed in practice.

Reduction of Risk of Stroke and Systemic Embolism in Patients with Nonvalvular Atrial Fibrillation

The safety of ELIQUIS was evaluated in the ARISTOTLE and AVERROES studies [*see Clinical Studies (14)*], including 11,284 patients exposed to ELIQUIS 5 mg twice daily and 602 patients exposed to ELIQUIS 2.5 mg twice daily. The duration of ELIQUIS exposure was ≥ 12 months for 9375 patients and ≥ 24 months for 3369 patients in the two studies. In ARISTOTLE, the mean duration of exposure was 89 weeks ($>15,000$ patient-years). In AVERROES, the mean duration of exposure was approximately 59 weeks (>3000 patient-years).

The most common reason for treatment discontinuation in both studies was for bleeding-related adverse reactions; in ARISTOTLE this occurred in 1.7% and 2.5% of patients treated with ELIQUIS and warfarin, respectively, and in AVERROES, in 1.5% and 1.3% on ELIQUIS and aspirin, respectively.

Bleeding in Patients with Nonvalvular Atrial Fibrillation in ARISTOTLE and AVERROES

Tables 1 and 2 show the number of patients experiencing major bleeding during the treatment period and the bleeding rate (percentage of subjects with at least one bleeding event per 100 patient-years) in ARISTOTLE and AVERROES.

Table 1: Bleeding Events in Patients with Nonvalvular Atrial Fibrillation in ARISTOTLE*

	ELIQUIS N=9088 n (per 100 pt-year)	Warfarin N=9052 n (per 100 pt-year)	Hazard Ratio (95% CI)	P-value
Major [†]	327 (2.13)	462 (3.09)	0.69 (0.60, 0.80)	<0.0001
Intracranial (ICH) [‡]	52 (0.33)	125 (0.82)	0.41 (0.30, 0.57)	-
Hemorrhagic stroke [§]	38 (0.24)	74 (0.49)	0.51 (0.34, 0.75)	-
Other ICH	15 (0.10)	51 (0.34)	0.29 (0.16, 0.51)	-
Gastrointestinal (GI) [¶]	128 (0.83)	141 (0.93)	0.89 (0.70, 1.14)	-
Fatal**	10 (0.06)	37 (0.24)	0.27 (0.13, 0.53)	-
Intracranial	4 (0.03)	30 (0.20)	0.13 (0.05, 0.37)	-
Non-intracranial	6 (0.04)	7 (0.05)	0.84 (0.28, 2.15)	-

* Bleeding events within each subcategory were counted once per subject, but subjects may have contributed events to multiple endpoints. Bleeding events were counted during treatment or within 2 days of stopping study treatment (on-treatment period).

[†] Defined as clinically overt bleeding accompanied by one or more of the following: a decrease in hemoglobin of ≥ 2 g/dL, a transfusion of 2 or more units of packed red blood cells, bleeding at a critical site: intracranial, intraspinal, intraocular, pericardial, intra-articular, intramuscular with compartment syndrome, retroperitoneal or with fatal outcome.

[‡] Intracranial bleed includes intracerebral, intraventricular, subdural, and subarachnoid bleeding. Any type of hemorrhagic stroke was adjudicated and counted as an intracranial major bleed.

[§] On-treatment analysis based on the safety population, compared to ITT analysis presented in Section 14.

[¶] GI bleed includes upper GI, lower GI, and rectal bleeding.

**Fatal bleeding is an adjudicated death with the primary cause of death as intracranial bleeding or non-intracranial bleeding during the on-treatment period.

In ARISTOTLE, the results for major bleeding were generally consistent across most major subgroups including age, weight, CHADS₂ score (a scale from 0 to 6 used to estimate risk of stroke, with higher scores predicting greater risk), prior warfarin use, geographic region, and aspirin use at randomization (Figure 1). Subjects treated with ELIQUIS with diabetes bled more (3% per year) than did subjects without diabetes (1.9% per year).

Figure 1: Major Bleeding Hazard Ratios by Baseline Characteristics – ARISTOTLE Study

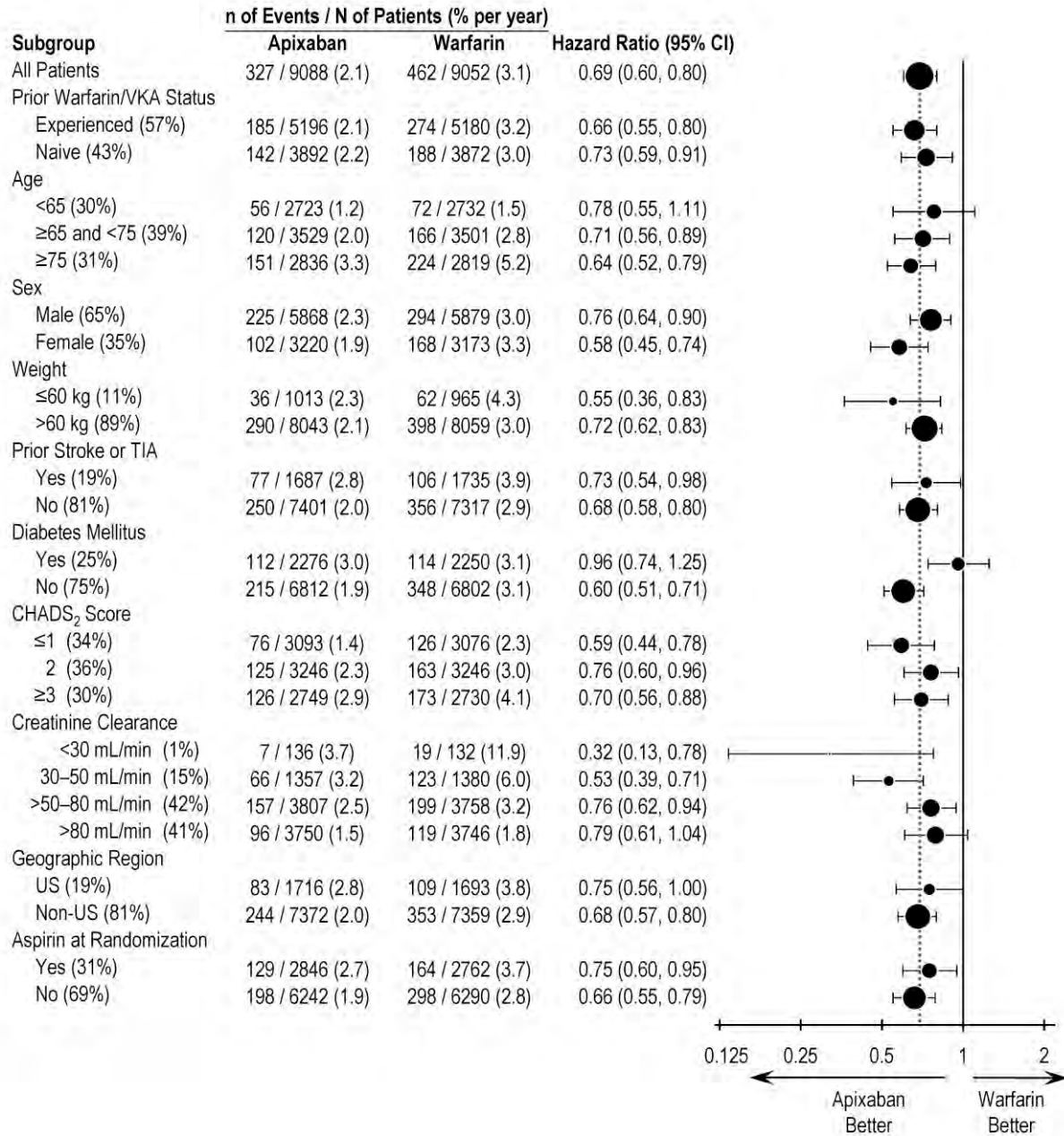

Note: The figure above presents effects in various subgroups, all of which are baseline characteristics and all of which were prespecified, if not the groupings. The 95% confidence limits that are shown do not take into account how many comparisons were made, nor do they reflect the effect of a particular factor after adjustment for all other factors. Apparent homogeneity or heterogeneity among groups should not be over-interpreted.

Table 2: Bleeding Events in Patients with Nonvalvular Atrial Fibrillation in AVERROES

	ELIQUIS N=2798 n (%/year)	Aspirin N=2780 n (%/year)	Hazard Ratio (95% CI)	P-value
Major	45 (1.41)	29 (0.92)	1.54 (0.96, 2.45)	0.07
Fatal	5 (0.16)	5 (0.16)	0.99 (0.23, 4.29)	-
Intracranial	11 (0.34)	11 (0.35)	0.99 (0.39, 2.51)	-

Events associated with each endpoint were counted once per subject, but subjects may have contributed events to multiple endpoints.

Other Adverse Reactions

Hypersensitivity reactions (including drug hypersensitivity, such as skin rash, and anaphylactic reactions, such as allergic edema) and syncope were reported in <1% of patients receiving ELIQUIS.

Prophylaxis of Deep Vein Thrombosis Following Hip or Knee Replacement Surgery

The safety of ELIQUIS has been evaluated in 1 Phase II and 3 Phase III studies including 5924 patients exposed to ELIQUIS 2.5 mg twice daily undergoing major orthopedic surgery of the lower limbs (elective hip replacement or elective knee replacement) treated for up to 38 days.

In total, 11% of the patients treated with ELIQUIS 2.5 mg twice daily experienced adverse reactions.

Bleeding results during the treatment period in the Phase III studies are shown in Table 3. Bleeding was assessed in each study beginning with the first dose of double-blind study drug.

Table 3: Bleeding During the Treatment Period in Patients Undergoing Elective Hip or Knee Replacement Surgery

Bleeding Endpoint*	ADVANCE-3 Hip Replacement Surgery		ADVANCE-2 Knee Replacement Surgery		ADVANCE-1 Knee Replacement Surgery	
	ELIQUIS 2.5 mg po bid 35±3 days	Enoxaparin 40 mg sc qd 35±3 days	ELIQUIS 2.5 mg po bid 12±2 days	Enoxaparin 40 mg sc qd 12±2 days	ELIQUIS 2.5 mg po bid 12±2 days	Enoxaparin 30 mg sc q12h 12±2 days
	First dose 12 to 24 hours post surgery	First dose 9 to 15 hours prior to surgery	First dose 12 to 24 hours post surgery	First dose 9 to 15 hours prior to surgery	First dose 12 to 24 hours post surgery	First dose 12 to 24 hours post surgery
All treated	N=2673	N=2659	N=1501	N=1508	N=1596	N=1588
Major (including surgical site)	22 (0.82%) [†]	18 (0.68%)	9 (0.60%) [‡]	14 (0.93%)	11 (0.69%)	22 (1.39%)
Fatal	0	0	0	0	0	1 (0.06%)
Hgb decrease ≥2 g/dL	13 (0.49%)	10 (0.38%)	8 (0.53%)	9 (0.60%)	10 (0.63%)	16 (1.01%)
Transfusion of ≥2 units RBC	16 (0.60%)	14 (0.53%)	5 (0.33%)	9 (0.60%)	9 (0.56%)	18 (1.13%)
Bleed at critical site [§]	1 (0.04%)	1 (0.04%)	1 (0.07%)	2 (0.13%)	1 (0.06%)	4 (0.25%)
Major + CRNM [¶]	129 (4.83%)	134 (5.04%)	53 (3.53%)	72 (4.77%)	46 (2.88%)	68 (4.28%)
All	313 (11.71%)	334 (12.56%)	104 (6.93%)	126 (8.36%)	85 (5.33%)	108 (6.80%)

* All bleeding criteria included surgical site bleeding.

[†] Includes 13 subjects with major bleeding events that occurred before the first dose of ELIQUIS (administered 12 to 24 hours post-surgery).

[‡] Includes 5 subjects with major bleeding events that occurred before the first dose of ELIQUIS (administered 12 to 24 hours post-surgery).

[§] Intracranial, intraspinal, intraocular, pericardial, an operated joint requiring re-operation or intervention, intramuscular with compartment syndrome, or retroperitoneal. Bleeding into an operated joint requiring re-operation or intervention was present in all patients with this category of bleeding. Events and event rates include one enoxaparin-treated patient in ADVANCE-1 who also had intracranial hemorrhage.

[¶] CRNM = clinically relevant nonmajor.

Adverse reactions occurring in ≥1% of patients undergoing hip or knee replacement surgery in the 1 Phase II study and the 3 Phase III studies are listed in Table 4.

Table 4: Adverse Reactions Occurring in $\geq 1\%$ of Patients in Either Group Undergoing Hip or Knee Replacement Surgery

	ELIQUIS, n (%) 2.5 mg po bid N=5924	Enoxaparin, n (%) 40 mg sc qd or 30 mg sc q12h N=5904
Nausea	153 (2.6)	159 (2.7)
Anemia (including postoperative and hemorrhagic anemia, and respective laboratory parameters)	153 (2.6)	178 (3.0)
Contusion	83 (1.4)	115 (1.9)
Hemorrhage (including hematoma, and vaginal and urethral hemorrhage)	67 (1.1)	81 (1.4)
Postprocedural hemorrhage (including postprocedural hematoma, wound hemorrhage, vessel puncture-site hematoma, and catheter-site hemorrhage)	54 (0.9)	60 (1.0)
Transaminases increased (including alanine aminotransferase increased and alanine aminotransferase abnormal)	50 (0.8)	71 (1.2)
Aspartate aminotransferase increased	47 (0.8)	69 (1.2)
Gamma-glutamyltransferase increased	38 (0.6)	65 (1.1)

Less common adverse reactions in ELIQUIS-treated patients undergoing hip or knee replacement surgery occurring at a frequency of $\geq 0.1\%$ to $< 1\%$:

Blood and lymphatic system disorders: thrombocytopenia (including platelet count decreases)

Vascular disorders: hypotension (including procedural hypotension)

Respiratory, thoracic, and mediastinal disorders: epistaxis

Gastrointestinal disorders: gastrointestinal hemorrhage (including hematemesis and melena), hematochezia

Hepatobiliary disorders: liver function test abnormal, blood alkaline phosphatase increased, blood bilirubin increased

Renal and urinary disorders: hematuria (including respective laboratory parameters)

Injury, poisoning, and procedural complications: wound secretion, incision-site hemorrhage (including incision-site hematoma), operative hemorrhage

Less common adverse reactions in ELIQUIS-treated patients undergoing hip or knee replacement surgery occurring at a frequency of $< 0.1\%$:

Gingival bleeding, hemoptysis, hypersensitivity, muscle hemorrhage, ocular hemorrhage (including conjunctival hemorrhage), rectal hemorrhage

Treatment of DVT and PE and Reduction in the Risk of Recurrence of DVT or PE

The safety of ELIQUIS has been evaluated in the AMPLIFY and AMPLIFY-EXT studies, including 2676 patients exposed to ELIQUIS 10 mg twice daily, 3359 patients exposed to ELIQUIS 5 mg twice daily, and 840 patients exposed to ELIQUIS 2.5 mg twice daily.

Common adverse reactions ($\geq 1\%$) were gingival bleeding, epistaxis, contusion, hematuria, rectal hemorrhage, hematoma, menorrhagia, and hemoptysis.

AMPLIFY Study

The mean duration of exposure to ELIQUIS was 154 days and to enoxaparin/warfarin was 152 days in the AMPLIFY study. Adverse reactions related to bleeding occurred in 417 (15.6%) ELIQUIS-treated patients compared to 661 (24.6%) enoxaparin/warfarin-treated patients. The discontinuation rate due to bleeding events was 0.7% in the ELIQUIS-treated patients compared to 1.7% in enoxaparin/warfarin-treated patients in the AMPLIFY study.

In the AMPLIFY study, ELIQUIS was statistically superior to enoxaparin/warfarin in the primary safety endpoint of major bleeding (relative risk 0.31, 95% CI [0.17, 0.55], P-value <0.0001).

Bleeding results from the AMPLIFY study are summarized in Table 5.

Table 5: Bleeding Results in the AMPLIFY Study

	ELIQUIS N=2676 n (%)	Enoxaparin/Warfarin N=2689 n (%)	Relative Risk (95% CI)
Major	15 (0.6)	49 (1.8)	0.31 (0.17, 0.55) p<0.0001
CRNM*	103 (3.9)	215 (8.0)	
Major + CRNM	115 (4.3)	261 (9.7)	
Minor	313 (11.7)	505 (18.8)	
All	402 (15.0)	676 (25.1)	

* CRNM = clinically relevant nonmajor bleeding.

Events associated with each endpoint were counted once per subject, but subjects may have contributed events to multiple endpoints.

Adverse reactions occurring in $\geq 1\%$ of patients in the AMPLIFY study are listed in Table 6.

Table 6: Adverse Reactions Occurring in $\geq 1\%$ of Patients Treated for DVT and PE in the AMPLIFY Study

	ELIQUIS N=2676 n (%)	Enoxaparin/Warfarin N=2689 n (%)
Epistaxis	77 (2.9)	146 (5.4)
Contusion	49 (1.8)	97 (3.6)
Hematuria	46 (1.7)	102 (3.8)
Menorrhagia	38 (1.4)	30 (1.1)
Hematoma	35 (1.3)	76 (2.8)
Hemoptysis	32 (1.2)	31 (1.2)
Rectal hemorrhage	26 (1.0)	39 (1.5)
Gingival bleeding	26 (1.0)	50 (1.9)

AMPLIFY-EXT Study

The mean duration of exposure to ELIQUIS was approximately 330 days and to placebo was 312 days in the AMPLIFY-EXT study. Adverse reactions related to bleeding occurred in 219 (13.3%) ELIQUIS-treated patients compared to 72 (8.7%) placebo-treated patients. The discontinuation rate due to bleeding events was approximately 1% in the ELIQUIS-treated patients compared to 0.4% in those patients in the placebo group in the AMPLIFY-EXT study.

Bleeding results from the AMPLIFY-EXT study are summarized in Table 7.

Table 7: Bleeding Results in the AMPLIFY-EXT Study

	ELIQUIS 2.5 mg bid N=840 n (%)	ELIQUIS 5 mg bid N=811 n (%)	Placebo N=826 n (%)
Major	2 (0.2)	1 (0.1)	4 (0.5)
CRNM*	25 (3.0)	34 (4.2)	19 (2.3)
Major + CRNM	27 (3.2)	35 (4.3)	22 (2.7)
Minor	75 (8.9)	98 (12.1)	58 (7.0)
All	94 (11.2)	121 (14.9)	74 (9.0)

* CRNM = clinically relevant nonmajor bleeding.

Events associated with each endpoint were counted once per subject, but subjects may have contributed events to multiple endpoints.

Adverse reactions occurring in $\geq 1\%$ of patients in the AMPLIFY-EXT study are listed in Table 8.

Table 8: Adverse Reactions Occurring in $\geq 1\%$ of Patients Undergoing Extended Treatment for DVT and PE in the AMPLIFY-EXT Study

	ELIQUIS 2.5 mg bid N=840 n (%)	ELIQUIS 5 mg bid N=811 n (%)	Placebo N=826 n (%)
Epistaxis	13 (1.5)	29 (3.6)	9 (1.1)
Hematuria	12 (1.4)	17 (2.1)	9 (1.1)
Hematoma	13 (1.5)	16 (2.0)	10 (1.2)
Contusion	18 (2.1)	18 (2.2)	18 (2.2)
Gingival bleeding	12 (1.4)	9 (1.1)	3 (0.4)

Other Adverse Reactions

Less common adverse reactions in ELIQUIS-treated patients in the AMPLIFY or AMPLIFY-EXT studies occurring at a frequency of $\geq 0.1\%$ to $< 1\%$:

Blood and lymphatic system disorders: hemorrhagic anemia

Gastrointestinal disorders: hematochezia, hemorrhoidal hemorrhage, gastrointestinal hemorrhage, hematemesis, melena, anal hemorrhage

Injury, poisoning, and procedural complications: wound hemorrhage, postprocedural hemorrhage, traumatic hematoma, periorbital hematoma

Musculoskeletal and connective tissue disorders: muscle hemorrhage

Reproductive system and breast disorders: vaginal hemorrhage, metrorrhagia, menometrorrhagia, genital hemorrhage

Vascular disorders: hemorrhage

Skin and subcutaneous tissue disorders: ecchymosis, skin hemorrhage, petechiae

Eye disorders: conjunctival hemorrhage, retinal hemorrhage, eye hemorrhage

Investigations: blood urine present, occult blood positive, occult blood, red blood cells urine positive

General disorders and administration-site conditions: injection-site hematoma, vessel puncture-site hematoma

7 DRUG INTERACTIONS

Apixaban is a substrate of both CYP3A4 and P-gp. Inhibitors of CYP3A4 and P-gp increase exposure to apixaban and increase the risk of bleeding. Inducers of CYP3A4 and P-gp decrease exposure to apixaban and increase the risk of stroke and other thromboembolic events.

7.1 Combined P-gp and Strong CYP3A4 Inhibitors

For patients receiving ELIQUIS 5 mg or 10 mg twice daily, the dose of ELIQUIS should be decreased by 50% when coadministered with drugs that are combined P-gp and strong CYP3A4 inhibitors (e.g., ketoconazole, itraconazole, ritonavir) [see *Dosage and Administration (2.5) and Clinical Pharmacology (12.3)*].

For patients receiving ELIQUIS at a dose of 2.5 mg twice daily, avoid coadministration with combined P-gp and strong CYP3A4 inhibitors [see *Dosage and Administration (2.5)* and *Clinical Pharmacology (12.3)*].

Clarithromycin

Although clarithromycin is a combined P-gp and strong CYP3A4 inhibitor, pharmacokinetic data suggest that no dose adjustment is necessary with concomitant administration with ELIQUIS [see *Clinical Pharmacology (12.3)*].

7.2 Combined P-gp and Strong CYP3A4 Inducers

Avoid concomitant use of ELIQUIS with combined P-gp and strong CYP3A4 inducers (e.g., rifampin, carbamazepine, phenytoin, St. John's wort) because such drugs will decrease exposure to apixaban [see *Clinical Pharmacology (12.3)*].

7.3 Anticoagulants and Antiplatelet Agents

Coadministration of antiplatelet agents, fibrinolytics, heparin, aspirin, and chronic NSAID use increases the risk of bleeding.

APPRAISE-2, a placebo-controlled clinical trial of ELIQUIS in high-risk, post-acute coronary syndrome patients treated with aspirin or the combination of aspirin and clopidogrel, was terminated early due to a higher rate of bleeding with ELIQUIS compared to placebo. The rate of ISTH major bleeding was 2.8% per year with ELIQUIS versus 0.6% per year with placebo in patients receiving single antiplatelet therapy and was 5.9% per year with ELIQUIS versus 2.5% per year with placebo in those receiving dual antiplatelet therapy.

In ARISTOTLE, concomitant use of aspirin increased the bleeding risk on ELIQUIS from 1.8% per year to 3.4% per year and concomitant use of aspirin and warfarin increased the bleeding risk from 2.7% per year to 4.6% per year. In this clinical trial, there was limited (2.3%) use of dual antiplatelet therapy with ELIQUIS.

8 USE IN SPECIFIC POPULATIONS

8.1 Pregnancy

Risk Summary

The limited available data on ELIQUIS use in pregnant women are insufficient to inform drug-associated risks of major birth defects, miscarriage, or adverse developmental outcomes. Treatment may increase the risk of bleeding during pregnancy and delivery. In animal reproduction studies, no adverse developmental effects were seen when apixaban was administered to rats (orally), rabbits (intravenously) and mice (orally) during organogenesis at unbound apixaban exposure levels up to 4, 1 and 19 times, respectively, the human exposure based on area under plasma-concentration time curve (AUC) at the Maximum Recommended Human Dose (MRHD) of 5 mg twice daily.

The estimated background risk of major birth defects and miscarriage for the indicated populations is unknown. All pregnancies have a background risk of birth defect, loss, or other adverse outcomes. In the U.S. general population, the estimated background risk of major birth defects and miscarriage in clinically recognized pregnancies is 2% to 4% and 15% to 20%, respectively.

Clinical Considerations

Disease-associated maternal and/or embryo/fetal risk

Pregnancy confers an increased risk of thromboembolism that is higher for women with underlying thromboembolic disease and certain high-risk pregnancy conditions. Published data describe that women with a previous history of venous thrombosis are at high risk for recurrence during pregnancy.

Fetal/Neonatal adverse reactions

Use of anticoagulants, including ELIQUIS, may increase the risk of bleeding in the fetus and neonate.

Labor or delivery

All patients receiving anticoagulants, including pregnant women, are at risk for bleeding. ELIQUIS use during labor or delivery in women who are receiving neuraxial anesthesia may result in epidural or spinal hematomas. Consider use of a shorter acting anticoagulant as delivery approaches [see *Warnings and Precautions (5.3)*].

Data

Animal Data

No developmental toxicities were observed when apixaban was administered during organogenesis to rats (orally), rabbits (intravenously) and mice (orally) at unbound apixaban exposure levels 4, 1, and 19 times, respectively, the human exposures at the MRHD. There was no evidence of fetal bleeding, although conceptus exposure was confirmed in rats and rabbits. Oral administration of apixaban to rat dams from gestation day 6 through lactation day 21 at maternal unbound apixaban exposures ranging from 1.4 to 5 times the human exposures at the MRHD was not associated with reduced maternal mortality or reduced conceptus/neonatal viability, although increased incidences of peri-vaginal bleeding were observed in dams at all doses. There was no evidence of neonatal bleeding.

8.2 Lactation

Risk Summary

There are no data on the presence of apixaban or its metabolites in human milk, the effects on the breastfed child, or the effects on milk production. Apixaban and/or its metabolites were present in the milk of rats (*see Data*). Because human exposure through milk is unknown, breastfeeding is not recommended during treatment with ELIQUIS.

Data

Animal Data

Maximal plasma concentrations were observed after 30 minutes following a single oral administration of a 5 mg dose to lactating rats. Maximal milk concentrations were observed 6 hours after dosing. The milk to plasma AUC (0-24) ratio is 30:1 indicating that apixaban can accumulate in milk. The concentrations of apixaban in animal milk does not necessarily predict the concentration of drug in human milk.

8.4 Pediatric Use

Safety and effectiveness in pediatric patients have not been established.

8.5 Geriatric Use

Of the total subjects in the ARISTOTLE and AVERROES clinical studies, >69% were 65 years of age and older, and >31% were 75 years of age and older. In the ADVANCE-1, ADVANCE-2, and ADVANCE-3 clinical studies, 50% of subjects were 65 years of age and older, while 16% were 75 years of age and older. In the AMPLIFY and AMPLIFY-EXT clinical studies, >32% of subjects were 65 years of age and older and >13% were 75 years of age and older. No clinically significant differences in safety or effectiveness were observed when comparing subjects in different age groups.

8.6 Renal Impairment

Reduction of Risk of Stroke and Systemic Embolism in Patients with Nonvalvular Atrial Fibrillation

The recommended dose is 2.5 mg twice daily in patients with at least two of the following characteristics [see *Dosage and Administration (2.1)*]:

- age greater than or equal to 80 years
- body weight less than or equal to 60 kg
- serum creatinine greater than or equal to 1.5 mg/dL

Patients with End-Stage Renal Disease on Dialysis

Clinical efficacy and safety studies with ELIQUIS did not enroll patients with end-stage renal disease (ESRD) on dialysis. In patients with ESRD maintained on intermittent hemodialysis, administration of ELIQUIS at the usually recommended dose [see *Dosage and Administration (2.1)*] will result in concentrations of apixaban and pharmacodynamic activity similar to those observed in the ARISTOTLE study [see *Clinical Pharmacology (12.3)*]. It is not known whether these concentrations will lead to similar stroke reduction and bleeding risk in patients with ESRD on dialysis as was seen in ARISTOTLE.

Prophylaxis of Deep Vein Thrombosis Following Hip or Knee Replacement Surgery, and Treatment of DVT and PE and Reduction in the Risk of Recurrence of DVT and PE

No dose adjustment is recommended for patients with renal impairment, including those with ESRD on dialysis [see *Dosage and Administration (2.1)*]. Clinical efficacy and safety studies with

ELIQUIS did not enroll patients with ESRD on dialysis or patients with a CrCl <15 mL/min; therefore, dosing recommendations are based on pharmacokinetic and pharmacodynamic (anti-FXa activity) data in subjects with ESRD maintained on dialysis [see *Clinical Pharmacology (12.3)*].

8.7 Hepatic Impairment

No dose adjustment is required in patients with mild hepatic impairment (Child-Pugh class A).

Because patients with moderate hepatic impairment (Child-Pugh class B) may have intrinsic coagulation abnormalities and there is limited clinical experience with ELIQUIS in these patients, dosing recommendations cannot be provided [see *Clinical Pharmacology (12.2)*].

ELIQUIS is not recommended in patients with severe hepatic impairment (Child-Pugh class C) [see *Clinical Pharmacology (12.2)*].

10 OVERDOSAGE

Overdose of ELIQUIS increases the risk of bleeding [see *Warnings and Precautions (5.2)*].

In controlled clinical trials, orally administered apixaban in healthy subjects at doses up to 50 mg daily for 3 to 7 days (25 mg twice daily for 7 days or 50 mg once daily for 3 days) had no clinically relevant adverse effects.

In healthy subjects, administration of activated charcoal 2 and 6 hours after ingestion of a 20-mg dose of apixaban reduced mean apixaban AUC by 50% and 27%, respectively. Thus, administration of activated charcoal may be useful in the management of ELIQUIS overdose or accidental ingestion. An agent to reverse the anti-factor Xa activity of apixaban is available.

11 DESCRIPTION

ELIQUIS (apixaban), a factor Xa (FXa) inhibitor, is chemically described as 1-(4-methoxyphenyl)-7-oxo-6-[4-(2-oxopiperidin-1-yl)phenyl]-4,5,6,7-tetrahydro-1H-pyrazolo[3,4-c]pyridine-3-carboxamide. Its molecular formula is C₂₅H₂₅N₅O₄, which corresponds to a molecular weight of 459.5. Apixaban has the following structural formula:

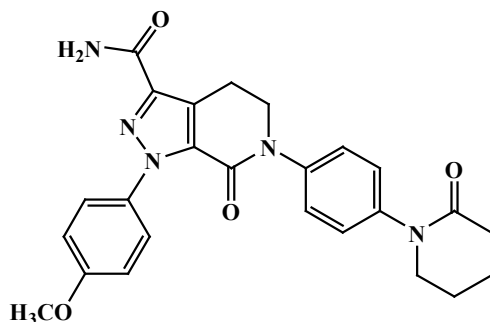

Apixaban is a white to pale-yellow powder. At physiological pH (1.2-6.8), apixaban does not ionize; its aqueous solubility across the physiological pH range is ~0.04 mg/mL.

ELIQUIS tablets are available for oral administration in strengths of 2.5 mg and 5 mg of apixaban with the following inactive ingredients: anhydrous lactose, microcrystalline cellulose, croscarmellose sodium, sodium lauryl sulfate, and magnesium stearate. The film coating contains lactose monohydrate, hypromellose, titanium dioxide, triacetin, and yellow iron oxide (2.5 mg tablets) or red iron oxide (5 mg tablets).

12 CLINICAL PHARMACOLOGY

12.1 Mechanism of Action

Apixaban is a selective inhibitor of FXa. It does not require antithrombin III for antithrombotic activity. Apixaban inhibits free and clot-bound FXa, and prothrombinase activity. Apixaban has no direct effect on platelet aggregation, but indirectly inhibits platelet aggregation induced by thrombin. By inhibiting FXa, apixaban decreases thrombin generation and thrombus development.

12.2 Pharmacodynamics

As a result of FXa inhibition, apixaban prolongs clotting tests such as prothrombin time (PT), INR, and activated partial thromboplastin time (aPTT). Changes observed in these clotting tests at the expected therapeutic dose, however, are small, subject to a high degree of variability, and not useful in monitoring the anticoagulation effect of apixaban.

The Rotachrom[®] Heparin chromogenic assay was used to measure the effect of apixaban on FXa activity in humans during the apixaban development program. A concentration-dependent increase in anti-FXa activity was observed in the dose range tested and was similar in healthy subjects and patients with AF.

This test is not recommended for assessing the anticoagulant effect of apixaban.

Effect of PCCs on Pharmacodynamics of ELIQUIS

There is no clinical experience to reverse bleeding with the use of 4-factor PCC products in individuals who have received ELIQUIS.

Effects of 4-factor PCCs on the pharmacodynamics of apixaban were studied in healthy subjects. Following administration of apixaban dosed to steady state, endogenous thrombin potential (ETP) returned to pre-apixaban levels 4 hours after the initiation of a 30-minute PCC infusion, compared to 45 hours with placebo. Mean ETP levels continued to increase and exceeded pre-apixaban levels reaching a maximum (34%-51% increase over pre-apixaban levels) at 21 hours after initiating PCC and remained elevated (21%-27% increase) at the end of the study (69 hours after initiation of PCC). The clinical relevance of this increase in ETP is unknown.

Pharmacodynamic Drug Interaction Studies

Pharmacodynamic drug interaction studies with aspirin, clopidogrel, aspirin and clopidogrel, prasugrel, enoxaparin, and naproxen were conducted. No pharmacodynamic interactions were observed with aspirin, clopidogrel, or prasugrel [see *Warnings and Precautions (5.2)*]. A 50% to 60% increase in anti-FXa activity was observed when ELIQUIS was coadministered with enoxaparin or naproxen.

Specific Populations

Renal impairment: Anti-FXa activity adjusted for exposure to apixaban was similar across renal function categories.

Hepatic impairment: Changes in anti-FXa activity were similar in patients with mild-to-moderate hepatic impairment and healthy subjects. However, in patients with moderate hepatic impairment, there is no clear understanding of the impact of this degree of hepatic function impairment on the coagulation cascade and its relationship to efficacy and bleeding. Patients with severe hepatic impairment were not studied.

Cardiac Electrophysiology

Apixaban has no effect on the QTc interval in humans at doses up to 50 mg.

12.3 Pharmacokinetics

Apixaban demonstrates linear pharmacokinetics with dose-proportional increases in exposure for oral doses up to 10 mg.

Absorption

The absolute bioavailability of apixaban is approximately 50% for doses up to 10 mg of ELIQUIS. Food does not affect the bioavailability of apixaban. Maximum concentrations (C_{max}) of apixaban appear 3 to 4 hours after oral administration of ELIQUIS. At doses ≥ 25 mg, apixaban displays dissolution-limited absorption with decreased bioavailability. Following oral administration of 10 mg of apixaban as 2 crushed 5 mg tablets suspended in 30 mL of water, exposure was similar to that after oral administration of 2 intact 5 mg tablets. Following oral administration of 10 mg of apixaban as 2 crushed 5 mg tablets mixed with 30 g of applesauce, the C_{max} and AUC were 20% and 16% lower, respectively, when compared to administration of 2 intact 5 mg tablets. Following administration of a crushed 5 mg ELIQUIS tablet that was suspended in 60 mL D5W and delivered through a nasogastric tube, exposure was similar to that seen in other clinical trials involving healthy volunteers receiving a single oral 5 mg tablet dose.

Distribution

Plasma protein binding in humans is approximately 87%. The volume of distribution (V_{ss}) is approximately 21 liters.

Metabolism

Approximately 25% of an orally administered apixaban dose is recovered in urine and feces as metabolites. Apixaban is metabolized mainly via CYP3A4 with minor contributions from CYP1A2, 2C8, 2C9, 2C19, and 2J2. O-demethylation and hydroxylation at the 3-oxopiperidinyl moiety are the major sites of biotransformation.

Unchanged apixaban is the major drug-related component in human plasma; there are no active circulating metabolites.

Elimination

Apixaban is eliminated in both urine and feces. Renal excretion accounts for about 27% of total clearance. Biliary and direct intestinal excretion contributes to elimination of apixaban in the feces.

Apixaban has a total clearance of approximately 3.3 L/hour and an apparent half-life of approximately 12 hours following oral administration.

Apixaban is a substrate of transport proteins: P-gp and breast cancer resistance protein.

Drug Interaction Studies

In *in vitro* apixaban studies at concentrations significantly greater than therapeutic exposures, no inhibitory effect on the activity of CYP1A2, CYP2A6, CYP2B6, CYP2C8, CYP2C9, CYP2D6, CYP3A4/5, or CYP2C19, nor induction effect on the activity of CYP1A2, CYP2B6, or CYP3A4/5 were observed. Therefore, apixaban is not expected to alter the metabolic clearance of coadministered drugs that are metabolized by these enzymes. Apixaban is not a significant inhibitor of P-gp.

The effects of coadministered drugs on the pharmacokinetics of apixaban are summarized in Figure 2 [see also Warnings and Precautions (5.2) and Drug Interactions (7)].

Figure 2: Effect of Coadministered Drugs on the Pharmacokinetics of Apixaban

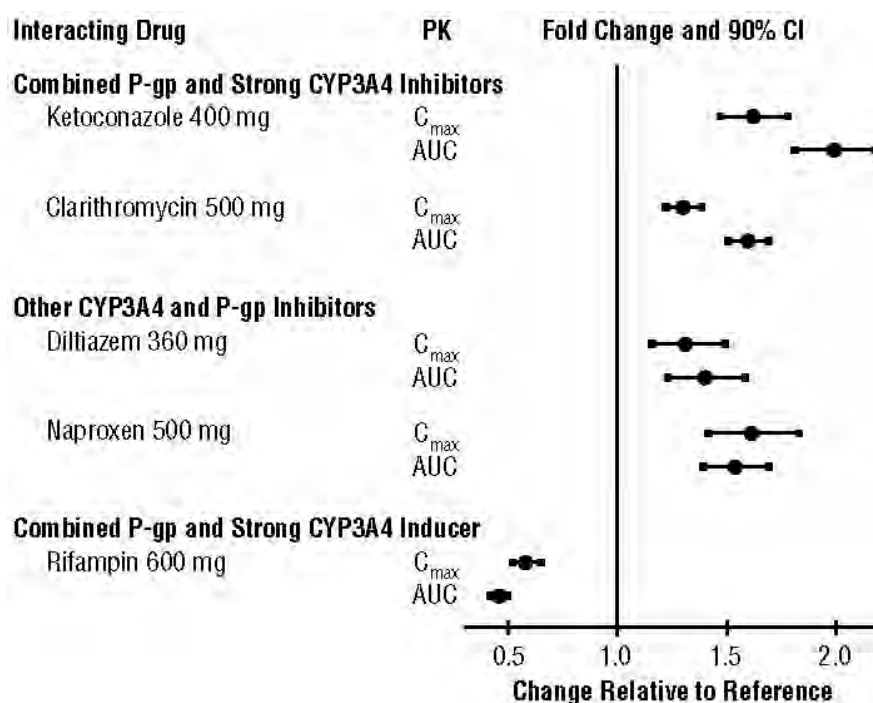

In dedicated studies conducted in healthy subjects, famotidine, atenolol, prasugrel, and enoxaparin did not meaningfully alter the pharmacokinetics of apixaban.

In studies conducted in healthy subjects, apixaban did not meaningfully alter the pharmacokinetics of digoxin, naproxen, atenolol, prasugrel, or acetylsalicylic acid.

Specific Populations

The effects of level of renal impairment, age, body weight, and level of hepatic impairment on the pharmacokinetics of apixaban are summarized in Figure 3.

Figure 3: Effect of Specific Populations on the Pharmacokinetics of Apixaban

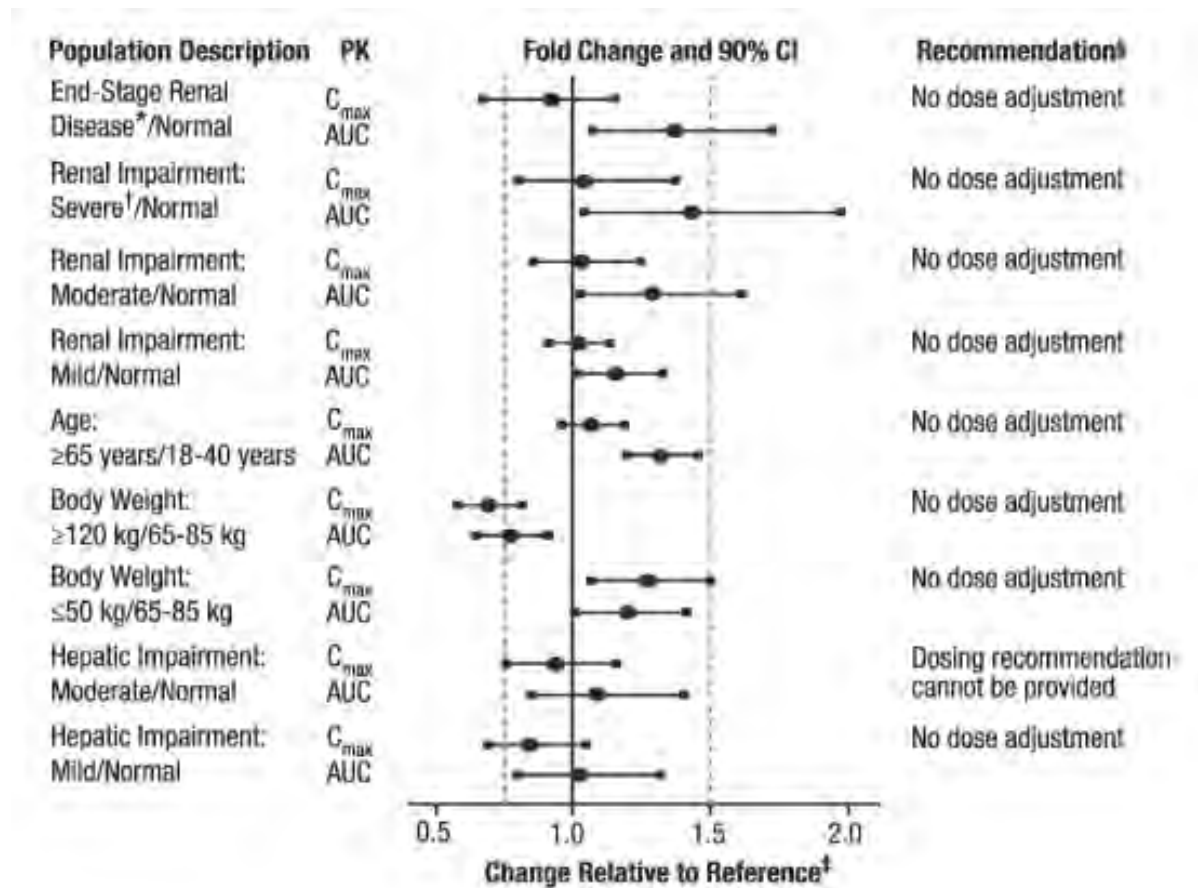

* ESRD subjects treated with intermittent hemodialysis; reported PK findings are following single dose of apixaban post hemodialysis.

[†] Results reflect CrCl of 15 mL/min based on regression analysis.

[‡] Dashed vertical lines illustrate pharmacokinetic changes that were used to inform dosing recommendations.

[§] No dose adjustment is recommended for nonvalvular atrial fibrillation patients unless at least 2 of the following patient characteristics (age greater than or equal to 80 years, body weight less than or equal to 60 kg, or serum creatinine greater than or equal to 1.5 mg/dL) are present.

Gender: A study in healthy subjects comparing the pharmacokinetics in males and females showed no meaningful difference.

Race: The results across pharmacokinetic studies in normal subjects showed no differences in apixaban pharmacokinetics among White/Caucasian, Asian, and Black/African American subjects. No dose adjustment is required based on race/ethnicity.

Hemodialysis in ESRD subjects: Systemic exposure to apixaban administered as a single 5 mg dose in ESRD subjects dosed immediately after the completion of a 4-hour hemodialysis session

(post-dialysis) is 36% higher when compared to subjects with normal renal function (Figure 3). The systemic exposure to apixaban administered 2 hours prior to a 4-hour hemodialysis session with a dialysate flow rate of 500 mL/min and a blood flow rate in the range of 350 to 500 mL/min is 17% higher compared to those with normal renal function. The dialysis clearance of apixaban is approximately 18 mL/min. The systemic exposure of apixaban is 14% lower on dialysis when compared to not on dialysis.

Protein binding was similar (92%-94%) between healthy controls and ESRD subjects during the on-dialysis and off-dialysis periods.

13 NONCLINICAL TOXICOLOGY

13.1 Carcinogenesis, Mutagenesis, Impairment of Fertility

Carcinogenesis: Apixaban was not carcinogenic when administered to mice and rats for up to 2 years. The systemic exposures (AUCs) of unbound apixaban in male and female mice at the highest doses tested (1500 and 3000 mg/kg/day) were 9 and 20 times, respectively, the human exposure of unbound drug at the MRHD of 10 mg/day. Systemic exposures of unbound apixaban in male and female rats at the highest dose tested (600 mg/kg/day) were 2 and 4 times, respectively, the human exposure.

Mutagenesis: Apixaban was neither mutagenic in the bacterial reverse mutation (Ames) assay, nor clastogenic in Chinese hamster ovary cells *in vitro*, in a 1-month *in vivo/in vitro* cytogenetics study in rat peripheral blood lymphocytes, or in a rat micronucleus study *in vivo*.

Impairment of Fertility: Apixaban had no effect on fertility in male or female rats when given at doses up to 600 mg/kg/day, a dose resulting in unbound apixaban exposure levels that are 3 and 4 times, respectively, the human exposure.

Apixaban administered to female rats at doses up to 1000 mg/kg/day from implantation through the end of lactation produced no adverse findings in male offspring (F1 generation) at doses up to 1000 mg/kg/day, a dose resulting in exposure to unbound apixaban that is 5 times the human exposure. Adverse effects in the F1-generation female offspring were limited to decreased mating and fertility indices at ≥ 200 mg/kg/day (a dose resulting in exposure to unbound apixaban that is ≥ 5 times the human exposure).

14 CLINICAL STUDIES

14.1 Reduction of Risk of Stroke and Systemic Embolism in Nonvalvular Atrial Fibrillation

ARISTOTLE

Evidence for the efficacy and safety of ELIQUIS was derived from ARISTOTLE, a multinational, double-blind study in patients with nonvalvular AF comparing the effects of ELIQUIS and warfarin on the risk of stroke and non-central nervous system (CNS) systemic embolism. In ARISTOTLE, patients were randomized to ELIQUIS 5 mg orally twice daily (or 2.5 mg twice daily in subjects with at least 2 of the following characteristics: age greater than or equal to

80 years, body weight less than or equal to 60 kg, or serum creatinine greater than or equal to 1.5 mg/dL) or to warfarin (targeted to an INR range of 2.0-3.0). Patients had to have one or more of the following additional risk factors for stroke:

- prior stroke or transient ischemic attack (TIA)
- prior systemic embolism
- age greater than or equal to 75 years
- arterial hypertension requiring treatment
- diabetes mellitus
- heart failure \geq New York Heart Association Class 2
- left ventricular ejection fraction \leq 40%

The primary objective of ARISTOTLE was to determine whether ELIQUIS 5 mg twice daily (or 2.5 mg twice daily) was effective (noninferior to warfarin) in reducing the risk of stroke (ischemic or hemorrhagic) and systemic embolism. Superiority of ELIQUIS to warfarin was also examined for the primary endpoint (rate of stroke and systemic embolism), major bleeding, and death from any cause.

A total of 18,201 patients were randomized and followed on study treatment for a median of 89 weeks. Forty-three percent of patients were vitamin K antagonist (VKA) “naive,” defined as having received \leq 30 consecutive days of treatment with warfarin or another VKA before entering the study. The mean age was 69 years and the mean CHADS₂ score (a scale from 0 to 6 used to estimate risk of stroke, with higher scores predicting greater risk) was 2.1. The population was 65% male, 83% Caucasian, 14% Asian, and 1% Black. There was a history of stroke, TIA, or non-CNS systemic embolism in 19% of patients. Concomitant diseases of patients in this study included hypertension 88%, diabetes 25%, congestive heart failure (or left ventricular ejection fraction \leq 40%) 35%, and prior myocardial infarction 14%. Patients treated with warfarin in ARISTOTLE had a mean percentage of time in therapeutic range (INR 2.0-3.0) of 62%.

ELIQUIS was superior to warfarin for the primary endpoint of reducing the risk of stroke and systemic embolism (Table 9 and Figure 4). Superiority to warfarin was primarily attributable to a reduction in hemorrhagic stroke and ischemic strokes with hemorrhagic conversion compared to warfarin. Purely ischemic strokes occurred with similar rates on both drugs.

ELIQUIS also showed significantly fewer major bleeds than warfarin [*see Adverse Reactions (6.1)*].

Table 9: Key Efficacy Outcomes in Patients with Nonvalvular Atrial Fibrillation in ARISTOTLE (Intent-to-Treat Analysis)

	ELIQUIS N=9120 n (%/year)	Warfarin N=9081 n (%/year)	Hazard Ratio (95% CI)	P-value
Stroke or systemic embolism	212 (1.27)	265 (1.60)	0.79 (0.66, 0.95)	0.01
Stroke	199 (1.19)	250 (1.51)	0.79 (0.65, 0.95)	
Ischemic without hemorrhage	140 (0.83)	136 (0.82)	1.02 (0.81, 1.29)	
Ischemic with hemorrhagic conversion	12 (0.07)	20 (0.12)	0.60 (0.29, 1.23)	
Hemorrhagic	40 (0.24)	78 (0.47)	0.51 (0.35, 0.75)	
Unknown	14 (0.08)	21 (0.13)	0.65 (0.33, 1.29)	
Systemic embolism	15 (0.09)	17 (0.10)	0.87 (0.44, 1.75)	

The primary endpoint was based on the time to first event (one per subject). Component counts are for subjects with any event, not necessarily the first.

Figure 4: Kaplan-Meier Estimate of Time to First Stroke or Systemic Embolism in ARISTOTLE (Intent-to-Treat Population)

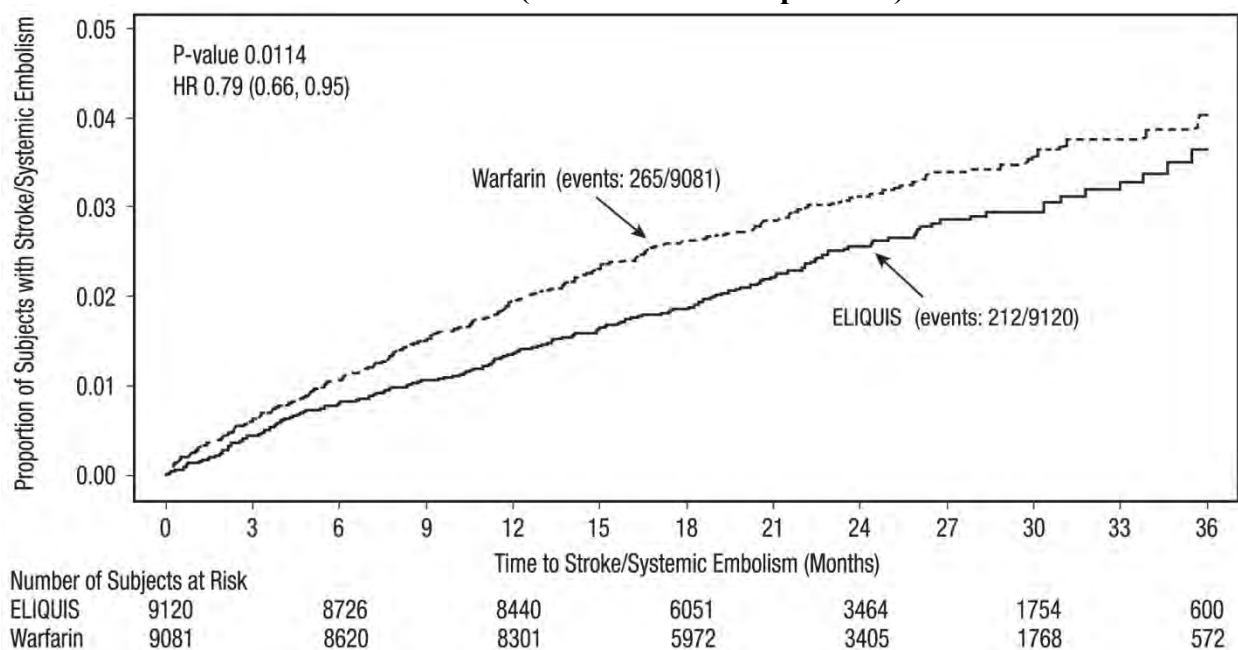

All-cause death was assessed using a sequential testing strategy that allowed testing for superiority if effects on earlier endpoints (stroke plus systemic embolus and major bleeding) were demonstrated. ELIQUIS treatment resulted in a significantly lower rate of all-cause death ($p = 0.046$) than did treatment with warfarin, primarily because of a reduction in cardiovascular death, particularly stroke deaths. Non vascular death rates were similar in the treatment arms.

In ARISTOTLE, the results for the primary efficacy endpoint were generally consistent across most major subgroups including weight, CHADS₂ score (a scale from 0 to 6 used to predict risk

of stroke in patients with AF, with higher scores predicting greater risk), prior warfarin use, level of renal impairment, geographic region, and aspirin use at randomization (Figure 5).

Figure 5: Stroke and Systemic Embolism Hazard Ratios by Baseline Characteristics – ARISTOTLE Study

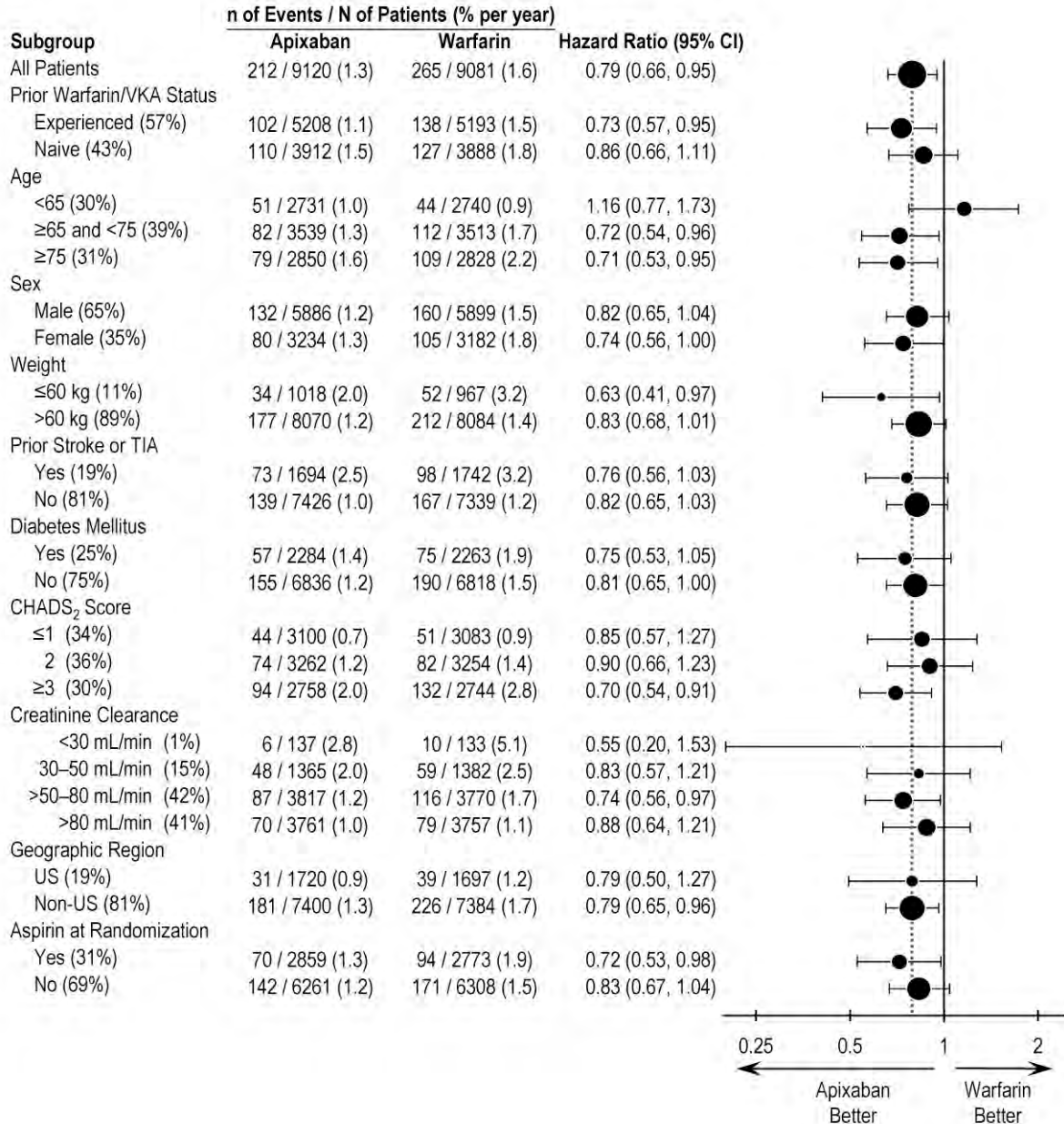

Note: The figure above presents effects in various subgroups, all of which are baseline characteristics and all of which were prespecified, if not the groupings. The 95% confidence limits that are shown do not take into account how many comparisons were made, nor do they reflect the effect of a particular factor after adjustment for all other factors. Apparent homogeneity or heterogeneity among groups should not be over-interpreted.

At the end of the ARISTOTLE study, warfarin patients who completed the study were generally maintained on a VKA with no interruption of anticoagulation. ELIQUIS patients who completed

the study were generally switched to a VKA with a 2-day period of coadministration of ELIQUIS and VKA, so that some patients may not have been adequately anticoagulated after stopping ELIQUIS until attaining a stable and therapeutic INR. During the 30 days following the end of the study, there were 21 stroke or systemic embolism events in the 6791 patients (0.3%) in the ELIQUIS arm compared to 5 in the 6569 patients (0.1%) in the warfarin arm [see *Dosage and Administration (2.4)*].

AVERROES

In AVERROES, patients with nonvalvular atrial fibrillation thought not to be candidates for warfarin therapy were randomized to treatment with ELIQUIS 5 mg orally twice daily (or 2.5 mg twice daily in selected patients) or aspirin 81 to 324 mg once daily. The primary objective of the study was to determine if ELIQUIS was superior to aspirin for preventing the composite outcome of stroke or systemic embolism. AVERROES was stopped early on the basis of a prespecified interim analysis showing a significant reduction in stroke and systemic embolism for ELIQUIS compared to aspirin that was associated with a modest increase in major bleeding (Table 10) [see *Adverse Reactions (6.1)*].

Table 10: Key Efficacy Outcomes in Patients with Nonvalvular Atrial Fibrillation in AVERROES

	ELIQUIS N=2807 n (%/year)	Aspirin N=2791 n (%/year)	Hazard Ratio (95% CI)	P-value
Stroke or systemic embolism	51 (1.62)	113 (3.63)	0.45 (0.32, 0.62)	<0.0001
Stroke				
Ischemic or undetermined	43 (1.37)	97 (3.11)	0.44 (0.31, 0.63)	-
Hemorrhagic	6 (0.19)	9 (0.28)	0.67 (0.24, 1.88)	-
Systemic embolism	2 (0.06)	13 (0.41)	0.15 (0.03, 0.68)	-
MI	24 (0.76)	28 (0.89)	0.86 (0.50, 1.48)	-
All-cause death	111 (3.51)	140 (4.42)	0.79 (0.62, 1.02)	0.068
Vascular death	84 (2.65)	96 (3.03)	0.87 (0.65, 1.17)	-

14.2 Prophylaxis of Deep Vein Thrombosis Following Hip or Knee Replacement Surgery

The clinical evidence for the effectiveness of ELIQUIS is derived from the ADVANCE-1, ADVANCE-2, and ADVANCE-3 clinical trials in adult patients undergoing elective hip (ADVANCE-3) or knee (ADVANCE-2 and ADVANCE-1) replacement surgery. A total of 11,659 patients were randomized in 3 double-blind, multi-national studies. Included in this total were 1866 patients age 75 or older, 1161 patients with low body weight (≤ 60 kg), 2528 patients with Body Mass Index ≥ 33 kg/m², and 625 patients with severe or moderate renal impairment.

In the ADVANCE-3 study, 5407 patients undergoing elective hip replacement surgery were randomized to receive either ELIQUIS 2.5 mg orally twice daily or enoxaparin 40 mg subcutaneously once daily. The first dose of ELIQUIS was given 12 to 24 hours post surgery,

whereas enoxaparin was started 9 to 15 hours prior to surgery. Treatment duration was 32 to 38 days.

In patients undergoing elective knee replacement surgery, ELIQUIS 2.5 mg orally twice daily was compared to enoxaparin 40 mg subcutaneously once daily (ADVANCE-2, N=3057) or enoxaparin 30 mg subcutaneously every 12 hours (ADVANCE-1, N=3195). In the ADVANCE-2 study, the first dose of ELIQUIS was given 12 to 24 hours post surgery, whereas enoxaparin was started 9 to 15 hours prior to surgery. In the ADVANCE-1 study, both ELIQUIS and enoxaparin were initiated 12 to 24 hours post surgery. Treatment duration in both ADVANCE-2 and ADVANCE-1 was 10 to 14 days.

In all 3 studies, the primary endpoint was a composite of adjudicated asymptomatic and symptomatic DVT, nonfatal PE, and all-cause death at the end of the double-blind intended treatment period. In ADVANCE-3 and ADVANCE-2, the primary endpoint was tested for noninferiority, then superiority, of ELIQUIS to enoxaparin. In ADVANCE-1, the primary endpoint was tested for noninferiority of ELIQUIS to enoxaparin.

The efficacy data are provided in Tables 11 and 12.

Table 11: Summary of Key Efficacy Analysis Results During the Intended Treatment Period for Patients Undergoing Elective Hip Replacement Surgery*

Events During 35-Day Treatment Period	ADVANCE-3		Relative Risk (95% CI) P-value
	ELIQUIS 2.5 mg po bid	Enoxaparin 40 mg sc qd	
Number of Patients	N=1949	N=1917	
Total VTE [†] /All-cause death	27 (1.39%) (0.95, 2.02)	74 (3.86%) (3.08, 4.83)	0.36 (0.22, 0.54) p<0.0001
Number of Patients	N=2708	N=2699	
All-cause death	3 (0.11%) (0.02, 0.35)	1 (0.04%) (0.00, 0.24)	
PE	3 (0.11%) (0.02, 0.35)	5 (0.19%) (0.07, 0.45)	
Symptomatic DVT	1 (0.04%) (0.00, 0.24)	5 (0.19%) (0.07, 0.45)	
Number of Patients	N=2196	N=2190	
Proximal DVT [‡]	7 (0.32%) (0.14, 0.68)	20 (0.91%) (0.59, 1.42)	
Number of Patients	N=1951	N=1908	
Distal DVT [‡]	20 (1.03%) (0.66, 1.59)	57 (2.99%) (2.31, 3.86)	

* Events associated with each endpoint were counted once per subject but subjects may have contributed events to multiple endpoints.

[†] Total VTE includes symptomatic and asymptomatic DVT and PE.

[‡] Includes symptomatic and asymptomatic DVT.

Table 12: Summary of Key Efficacy Analysis Results During the Intended Treatment Period for Patients Undergoing Elective Knee Replacement Surgery*

	ADVANCE-1			ADVANCE-2		
Events during 12-day treatment period	ELIQUIS 2.5 mg po bid	Enoxaparin 30 mg sc q12h	Relative Risk (95% CI) P-value	ELIQUIS 2.5 mg po bid	Enoxaparin 40 mg sc qd	Relative Risk (95% CI) P-value
Number of Patients	N=1157	N=1130		N=976	N=997	
Total VTE [†] /All-cause death	104 (8.99%) (7.47, 10.79)	100 (8.85%) (7.33, 10.66)	1.02 (0.78, 1.32) NS	147 (15.06%) (12.95, 17.46)	243 (24.37%) (21.81, 27.14)	0.62 (0.51, 0.74) p<0.0001
Number of Patients	N=1599	N=1596		N=1528	N=1529	
All-cause death	3 (0.19%) (0.04, 0.59)	3 (0.19%) (0.04, 0.59)		2 (0.13%) (0.01, 0.52)	0 (0%) (0.00, 0.31)	
PE	16 (1.0%) (0.61, 1.64)	7 (0.44%) (0.20, 0.93)		4 (0.26%) (0.08, 0.70)	0 (0%) (0.00, 0.31)	
Symptomatic DVT	3 (0.19%) (0.04, 0.59)	7 (0.44%) (0.20, 0.93)		3 (0.20%) (0.04, 0.61)	7 (0.46%) (0.20, 0.97)	
Number of Patients	N=1254	N=1207		N=1192	N=1199	
Proximal DVT [‡]	9 (0.72%) (0.36, 1.39)	11 (0.91%) (0.49, 1.65)		9 (0.76%) (0.38, 1.46)	26 (2.17%) (1.47, 3.18)	
Number of Patients	N=1146	N=1133		N=978	N=1000	
Distal DVT [‡]	83 (7.24%) (5.88, 8.91)	91 (8.03%) (6.58, 9.78)		142 (14.52%) (12.45, 16.88)	239 (23.9%) (21.36, 26.65)	

* Events associated with each endpoint were counted once per subject but subjects may have contributed events to multiple endpoints.

[†] Total VTE includes symptomatic and asymptomatic DVT and PE.

[‡] Includes symptomatic and asymptomatic DVT.

The efficacy profile of ELIQUIS was generally consistent across subgroups of interest for this indication (e.g., age, gender, race, body weight, renal impairment).

14.3 Treatment of DVT and PE and Reduction in the Risk of Recurrence of DVT and PE

Efficacy and safety of ELIQUIS for the treatment of DVT and PE, and for the reduction in the risk of recurrent DVT and PE following 6 to 12 months of anticoagulant treatment was derived from the AMPLIFY and AMPLIFY-EXT studies. Both studies were randomized, parallel-group, double-blind trials in patients with symptomatic proximal DVT and/or symptomatic PE. All key safety and efficacy endpoints were adjudicated in a blinded manner by an independent committee.

AMPLIFY

The primary objective of AMPLIFY was to determine whether ELIQUIS was noninferior to enoxaparin/warfarin for the incidence of recurrent VTE (venous thromboembolism) or VTE-related death. Patients with an objectively confirmed symptomatic DVT and/or PE were randomized to treatment with ELIQUIS 10 mg twice daily orally for 7 days followed by ELIQUIS 5 mg twice daily orally for 6 months, or enoxaparin 1 mg/kg twice daily subcutaneously for at least 5 days (until INR ≥ 2) followed by warfarin (target INR range 2.0-3.0) orally for 6 months. Patients who required thrombectomy, insertion of a caval filter, or use of a fibrinolytic agent, and patients with creatinine clearance < 25 mL/min, significant liver disease, an existing heart valve or atrial fibrillation, or active bleeding were excluded from the AMPLIFY study. Patients were allowed to enter the study with or without prior parenteral anticoagulation (up to 48 hours).

A total of 5244 patients were evaluable for efficacy and were followed for a mean of 154 days in the ELIQUIS group and 152 days in the enoxaparin/warfarin group. The mean age was 57 years. The AMPLIFY study population was 59% male, 83% Caucasian, 8% Asian, and 4% Black. For patients randomized to warfarin, the mean percentage of time in therapeutic range (INR 2.0-3.0) was 60.9%.

Approximately 90% of patients enrolled in AMPLIFY had an unprovoked DVT or PE at baseline. The remaining 10% of patients with a provoked DVT or PE were required to have an additional ongoing risk factor in order to be randomized, which included previous episode of DVT or PE, immobilization, history of cancer, active cancer, and known prothrombotic genotype.

ELIQUIS was shown to be noninferior to enoxaparin/warfarin in the AMPLIFY study for the primary endpoint of recurrent symptomatic VTE (nonfatal DVT or nonfatal PE) or VTE-related death over 6 months of therapy (Table 13).

Table 13: Efficacy Results in the AMPLIFY Study

	ELIQUIS N=2609 n	Enoxaparin/Warfarin N=2635 n	Relative Risk (95% CI)
VTE or VTE-related death*	59 (2.3%)	71 (2.7%)	0.84 (0.60, 1.18)
DVT [†]	22 (0.8%)	35 (1.3%)	
PE [†]	27 (1.0%)	25 (0.9%)	
VTE-related death [†]	12 (0.4%)	16 (0.6%)	
VTE or all-cause death	84 (3.2%)	104 (4.0%)	0.82 (0.61, 1.08)
VTE or CV-related death	61 (2.3%)	77 (2.9%)	0.80 (0.57, 1.11)

* Noninferior compared to enoxaparin/warfarin (P-value <0.0001).

[†] Events associated with each endpoint were counted once per subject, but subjects may have contributed events to multiple endpoints.

In the AMPLIFY study, patients were stratified according to their index event of PE (with or without DVT) or DVT (without PE). Efficacy in the initial treatment of VTE was consistent between the two subgroups.

AMPLIFY-EXT

Patients who had been treated for DVT and/or PE for 6 to 12 months with anticoagulant therapy without having a recurrent event were randomized to treatment with ELIQUIS 2.5 mg orally twice daily, ELIQUIS 5 mg orally twice daily, or placebo for 12 months. Approximately one-third of patients participated in the AMPLIFY study prior to enrollment in the AMPLIFY-EXT study.

A total of 2482 patients were randomized to study treatment and were followed for a mean of approximately 330 days in the ELIQUIS group and 312 days in the placebo group. The mean age in the AMPLIFY-EXT study was 57 years. The study population was 57% male, 85% Caucasian, 5% Asian, and 3% Black.

The AMPLIFY-EXT study enrolled patients with either an unprovoked DVT or PE at baseline (approximately 92%) or patients with a provoked baseline event and one additional risk factor for recurrence (approximately 8%). However, patients who had experienced multiple episodes of unprovoked DVT or PE were excluded from the AMPLIFY-EXT study. In the AMPLIFY-EXT study, both doses of ELIQUIS were superior to placebo in the primary endpoint of symptomatic, recurrent VTE (nonfatal DVT or nonfatal PE), or all-cause death (Table 14).

Table 14: Efficacy Results in the AMPLIFY-EXT Study

	ELIQUIS 2.5 mg bid N=840	ELIQUIS 5 mg bid N=813	Placebo N=829	Relative Risk (95% CI)	
				ELIQUIS 2.5 mg bid vs Placebo	ELIQUIS 5 mg bid vs Placebo
	n (%)				
Recurrent VTE or all-cause death	32 (3.8)	34 (4.2)	96 (11.6)	0.33 (0.22, 0.48) p<0.0001	0.36 (0.25, 0.53) p<0.0001
DVT*	19 (2.3)	28 (3.4)	72 (8.7)		
PE*	23 (2.7)	25 (3.1)	37 (4.5)		
All-cause death	22 (2.6)	25 (3.1)	33 (4.0)		

* Patients with more than one event are counted in multiple rows.

16 HOW SUPPLIED/STORAGE AND HANDLING

How Supplied

ELIQUIS (apixaban) tablets are available as listed in the table below.

Tablet Strength	Tablet Color/Shape	Tablet Markings	Package Size	NDC Code
2.5 mg	Yellow, round, biconvex	Debossed with “893” on one side and “2½” on the other side	Bottles of 60	0003-0893-21
			Hospital Unit-Dose Blister Package of 100	0003-0893-31
5 mg	Pink, oval, biconvex	Debossed with “894” on one side and “5” on the other side	Bottles of 60	0003-0894-21
			Bottles of 74	0003-0894-70
			Hospital Unit-Dose Blister Package of 100	0003-0894-31
			30-Day Starter Pack for Treatment of DVT and PE Containing 74 Tablets (1 blister pack of 42 tablets and 1 blister pack of 32 tablets)	0003-3764-74

Storage and Handling

Store at 20°C to 25°C (68°F-77°F); excursions permitted between 15°C and 30°C (59°F-86°F) [see USP Controlled Room Temperature].

17 PATIENT COUNSELING INFORMATION

Advise patients to read the FDA-approved patient labeling (Medication Guide).

Advise patients of the following:

- Not to discontinue ELIQUIS without talking to their physician first.
- That it might take longer than usual for bleeding to stop, and they may bruise or bleed more easily when treated with ELIQUIS. Advise patients about how to recognize bleeding or

symptoms of hypovolemia and of the urgent need to report any unusual bleeding to their physician.

- To tell their physicians and dentists they are taking ELIQUIS, and/or any other product known to affect bleeding (including nonprescription products, such as aspirin or NSAIDs), before any surgery or medical or dental procedure is scheduled and before any new drug is taken.
- If the patient is having neuraxial anesthesia or spinal puncture, inform the patient to watch for signs and symptoms of spinal or epidural hematomas [*see Warnings and Precautions (5.3)*]. If any of these symptoms occur, advise the patient to seek emergent medical attention.
- To tell their physicians if they are pregnant or plan to become pregnant or are breastfeeding or intend to breastfeed during treatment with ELIQUIS [*see Use in Specific Populations (8.1, 8.2)*].
- How to take ELIQUIS if they cannot swallow, or require a nasogastric tube [*see Dosage and Administration (2.6)*].
- What to do if a dose is missed [*see Dosage and Administration (2.2)*].

Marketed by:

Bristol-Myers Squibb Company
Princeton, New Jersey 08543 USA
and
Pfizer Inc
New York, New York 10017 USA

Rotachrom[®] is a registered trademark of Diagnostica Stago.

[PRINT CODES]

MEDICATION GUIDE
ELIQUIS® (ELL eh kwiss)
(apixaban)
tablets

What is the most important information I should know about ELIQUIS?

- **For people taking ELIQUIS for atrial fibrillation:**

People with atrial fibrillation (a type of irregular heartbeat) are at an increased risk of forming a blood clot in the heart, which can travel to the brain, causing a stroke, or to other parts of the body. ELIQUIS lowers your chance of having a stroke by helping to prevent clots from forming. If you stop taking ELIQUIS, you may have increased risk of forming a clot in your blood.

Do not stop taking ELIQUIS without talking to the doctor who prescribes it for you. Stopping ELIQUIS increases your risk of having a stroke.

ELIQUIS may need to be stopped, if possible, prior to surgery or a medical or dental procedure. Ask the doctor who prescribed ELIQUIS for you when you should stop taking it. Your doctor will tell you when you may start taking ELIQUIS again after your surgery or procedure. If you have to stop taking ELIQUIS, your doctor may prescribe another medicine to help prevent a blood clot from forming.

- **ELIQUIS can cause bleeding** which can be serious and rarely may lead to death. This is because ELIQUIS is a blood thinner medicine that reduces blood clotting.

You may have a higher risk of bleeding if you take ELIQUIS and take other medicines that increase your risk of bleeding, including:

- aspirin or aspirin-containing products
- long-term (chronic) use of nonsteroidal anti-inflammatory drugs (NSAIDs)
- warfarin sodium (COUMADIN®, JANTOVEN®)
- any medicine that contains heparin
- selective serotonin reuptake inhibitors (SSRIs) or serotonin norepinephrine reuptake inhibitors (SNRIs)
- other medicines to help prevent or treat blood clots

Tell your doctor if you take any of these medicines. Ask your doctor or pharmacist if you are not sure if your medicine is one listed above.

While taking ELIQUIS:

- you may bruise more easily
- it may take longer than usual for any bleeding to stop

Call your doctor or get medical help right away if you have any of these signs or symptoms of bleeding when taking ELIQUIS:

- unexpected bleeding, or bleeding that lasts a long time, such as:
 - unusual bleeding from the gums
 - nosebleeds that happen often
 - menstrual bleeding or vaginal bleeding that is heavier than normal

- bleeding that is severe or you cannot control
 - red, pink, or brown urine
 - red or black stools (looks like tar)
 - cough up blood or blood clots
 - vomit blood or your vomit looks like coffee grounds
 - unexpected pain, swelling, or joint pain
 - headaches, feeling dizzy or weak
- **ELIQUIS is not for patients with artificial heart valves.**
 - **Spinal or epidural blood clots (hematoma).** People who take a blood thinner medicine (anticoagulant) like ELIQUIS, and have medicine injected into their spinal and epidural area, or have a spinal puncture have a risk of forming a blood clot that can cause long-term or permanent loss of the ability to move (paralysis). Your risk of developing a spinal or epidural blood clot is higher if:
 - a thin tube called an epidural catheter is placed in your back to give you certain medicine
 - you take NSAIDs or a medicine to prevent blood from clotting
 - you have a history of difficult or repeated epidural or spinal punctures
 - you have a history of problems with your spine or have had surgery on your spine

If you take ELIQUIS and receive spinal anesthesia or have a spinal puncture, your doctor should watch you closely for symptoms of spinal or epidural blood clots or bleeding. Tell your doctor right away if you have tingling, numbness, or muscle weakness, especially in your legs and feet.
 - ELIQUIS is not for use in people with antiphospholipid syndrome (APS), especially with positive triple antibody testing, who have a history of blood clots.

What is ELIQUIS?

ELIQUIS is a prescription medicine used to:

- reduce the risk of stroke and blood clots in people who have atrial fibrillation.
- reduce the risk of forming a blood clot in the legs and lungs of people who have just had hip or knee replacement surgery.
- treat blood clots in the veins of your legs (deep vein thrombosis) or lungs (pulmonary embolism), and reduce the risk of them occurring again.

It is not known if ELIQUIS is safe and effective in children.

Who should not take ELIQUIS?

Do not take ELIQUIS if you:

- currently have certain types of abnormal bleeding.
- have had a serious allergic reaction to ELIQUIS. Ask your doctor if you are not sure.

What should I tell my doctor before taking ELIQUIS?

Before you take ELIQUIS, tell your doctor if you:

- have kidney or liver problems
- have antiphospholipid syndrome
- have any other medical condition
- have ever had bleeding problems
- are pregnant or plan to become pregnant. It is not known if ELIQUIS will harm your unborn baby.
- are breastfeeding or plan to breastfeed. It is not known if ELIQUIS passes into your breast milk. You and your doctor should decide if you will take ELIQUIS or breastfeed. You should not do both.

Tell all of your doctors and dentists that you are taking ELIQUIS. They should talk to the doctor who prescribed ELIQUIS for you, before you have **any** surgery, medical or dental procedure.

Tell your doctor about all the medicines you take, including prescription and over-the-counter medicines, vitamins, and herbal supplements. Some of your other medicines may affect the way ELIQUIS works. Certain medicines may increase your risk of bleeding or stroke when taken with ELIQUIS. See **“What is the most important information I should know about ELIQUIS?”**

Know the medicines you take. Keep a list of them to show your doctor and pharmacist when you get a new medicine.

How should I take ELIQUIS?

- **Take ELIQUIS exactly as prescribed by your doctor.**
- Take ELIQUIS twice every day with or without food.
- Do not change your dose or stop taking ELIQUIS unless your doctor tells you to.
- If you miss a dose of ELIQUIS, take it as soon as you remember. Do not take more than one dose of ELIQUIS at the same time to make up for a missed dose.
- If you have difficulty swallowing the tablet whole, talk to your doctor about other ways to take ELIQUIS.
- Your doctor will decide how long you should take ELIQUIS. **Do not stop taking it without first talking with your doctor. If you are taking ELIQUIS for atrial fibrillation, stopping ELIQUIS may increase your risk of having a stroke.**
- **Do not run out of ELIQUIS. Refill your prescription before you run out.** When leaving the hospital following hip or knee replacement, be sure that you will have ELIQUIS available to avoid missing any doses.
- If you take too much ELIQUIS, call your doctor or go to the nearest hospital emergency room right away.
- Call your doctor or healthcare provider right away if you fall or injure yourself, especially if you hit your head. Your doctor or healthcare provider may need to check you.

What are the possible side effects of ELIQUIS?

- See “**What is the most important information I should know about ELIQUIS?**”
- ELIQUIS can cause a skin rash or severe allergic reaction. Call your doctor or get medical help right away if you have any of the following symptoms:
 - chest pain or tightness
 - swelling of your face or tongue
 - trouble breathing or wheezing
 - feeling dizzy or faint

Tell your doctor if you have any side effect that bothers you or that does not go away.

These are not all of the possible side effects of ELIQUIS. For more information, ask your doctor or pharmacist.

Call your doctor for medical advice about side effects. You may report side effects to FDA at 1-800-FDA-1088.

How should I store ELIQUIS?

Store ELIQUIS at room temperature between 68°F to 77°F (20°C to 25°C).

Keep ELIQUIS and all medicines out of the reach of children.

General Information about ELIQUIS

Medicines are sometimes prescribed for purposes other than those listed in a Medication Guide. Do not use ELIQUIS for a condition for which it was not prescribed. Do not give ELIQUIS to other people, even if they have the same symptoms that you have. It may harm them.

If you would like more information, talk with your doctor. You can ask your pharmacist or doctor for information about ELIQUIS that is written for health professionals.

For more information, call 1-855-354-7847 (1-855-ELIQUIS) or go to www.ELIQUIS.com.

What are the ingredients in ELIQUIS?

Active ingredient: apixaban.

Inactive ingredients: anhydrous lactose, microcrystalline cellulose, croscarmellose sodium, sodium lauryl sulfate, and magnesium stearate. The film coating contains lactose monohydrate, hypromellose, titanium dioxide, triacetin, and yellow iron oxide (2.5 mg tablets) or red iron oxide (5 mg tablets).

This Medication Guide has been approved by the U.S. Food and Drug Administration.

Marketed by:
Bristol-Myers Squibb Company
Princeton, New Jersey 08543 USA
and
Pfizer Inc
New York, New York 10017 USA

COUMADIN[®] is a registered trademark of Bristol-Myers Squibb Pharma Company.

All other trademarks are property of their respective companies.

[PRINT CODES]

Revised November 2019

HIGHLIGHTS OF PRESCRIBING INFORMATION

These highlights do not include all the information needed to use FARXIGA safely and effectively. See full prescribing information for FARXIGA.

FARXIGA® (dapagliflozin) tablets, for oral use
Initial U.S. Approval: 2014

RECENT MAJOR CHANGES

Indications and Usage (1.1)	10/2019
Indications and Usage (1.2)	05/2020
Dosage and Administration (2.1)	10/2019
Dosage and Administration (2.2, 2.3, 2.4)	05/2020
Contraindications (4)	05/2020
Warnings and Precautions (5.1)	05/2020
Warnings and Precautions (5.2)	01/2020
Warnings and Precautions (5.4)	10/2019
Warnings and Precautions (5.8, 5.9, 5.10)	Removed 10/2019

INDICATIONS AND USAGE

FARXIGA is a sodium-glucose cotransporter 2 (SGLT2) inhibitor indicated in adults for:

Type 2 Diabetes Mellitus:

- as an adjunct to diet and exercise to improve glycemic control. (1.1)
- to reduce the risk of hospitalization for heart failure in adults with type 2 diabetes mellitus and established cardiovascular disease or multiple cardiovascular risk factors. (1.1)

Heart Failure:

- to reduce the risk of cardiovascular death and hospitalization for heart failure in adults with heart failure with reduced ejection fraction (NYHA class II-IV). (1.2)

Limitations of use:

- Not for treatment of type 1 diabetes mellitus or diabetic ketoacidosis. (1.3)

DOSAGE AND ADMINISTRATION

Assess renal function before initiating and then as clinically indicated. (2.1)

Type 2 Diabetes Mellitus:

- To improve glycemic control the recommended starting dose is 5 mg once daily, taken in the morning. Increase dose to 10 mg once daily in patients tolerating 5 mg who require additional glycemic control. (2.2)
- To reduce the risk of hospitalization for heart failure in adults with type 2 diabetes mellitus and established cardiovascular disease or multiple cardiovascular risk factors, the recommended dose is 10 mg once daily. (2.2)
- FARXIGA is not recommended for glycemic control when the eGFR is less than 45 mL/min/1.73 m². (2.4)

Heart Failure:

- The recommended dose of FARXIGA is 10 mg once daily. (2.3)

DOSAGE FORMS AND STRENGTHS

- Tablets: 5 mg and 10 mg (3)

CONTRAINDICATIONS

- History of serious hypersensitivity reaction to FARXIGA. (4)
- Severe renal impairment (eGFR less than 30 mL/min/1.73 m²) in patients who are being treated for glycemic control without established cardiovascular disease or cardiovascular risk factors. (4)
- Patients on dialysis. (4)

WARNINGS AND PRECAUTIONS

- **Volume depletion:** Before initiating FARXIGA, assess volume status and renal function in the elderly, patients with renal impairment or low systolic blood pressure, and in patients on diuretics. Monitor for signs and symptoms during therapy. (5.1, 6.1)
- **Ketoacidosis in Patients with Diabetes Mellitus:** Assess patients who present with signs and symptoms of metabolic acidosis for ketoacidosis regardless of blood glucose level. If suspected, discontinue FARXIGA, evaluate and treat promptly. Before initiating FARXIGA, consider risk factors for ketoacidosis. Patients on FARXIGA may require monitoring and temporary discontinuation of therapy in clinical situations known to predispose to ketoacidosis. (5.2)
- **Urosepsis and Pyelonephritis:** Evaluate for signs and symptoms of urinary tract infections and treat promptly, if indicated. (5.3)
- **Hypoglycemia:** Consider a lower dose of insulin or the insulin secretagogue to reduce the risk of hypoglycemia when used in combination with FARXIGA. (5.4)
- **Necrotizing Fasciitis of the Perineum (Fournier's Gangrene):** Serious, life-threatening cases have occurred in patients with diabetes, both females and males. Assess patients presenting with pain or tenderness, erythema, or swelling in the genital or perineal area, along with fever or malaise. If suspected, institute prompt treatment. (5.5)
- **Genital Mycotic Infections:** Monitor and treat if indicated. (5.6)

ADVERSE REACTIONS

- The most common adverse reactions associated with FARXIGA (5% or greater incidence) were female genital mycotic infections, nasopharyngitis, and urinary tract infections. (6.1)

To report SUSPECTED ADVERSE REACTIONS, contact AstraZeneca at 1-800-236-9933 or FDA at 1-800-FDA-1088 or www.fda.gov/medwatch.

USE IN SPECIFIC POPULATIONS

- **Pregnancy:** Advise females of the potential risk to a fetus especially during the second and third trimesters. (8.1)
- **Lactation:** FARXIGA is not recommended when breastfeeding. (8.2)
- **Geriatrics:** Higher incidence of adverse reactions related to hypotension. (5.1, 8.5)
- **Renal Impairment:** Higher incidence of adverse reactions related to hypotension and renal function. (5.1, 8.6)

See 17 for PATIENT COUNSELING INFORMATION and Medication Guide.

Revised: 05/2020

FULL PRESCRIBING INFORMATION: CONTENTS*

1 INDICATIONS AND USAGE

- 1.1 Type 2 Diabetes Mellitus
- 1.2 Heart Failure
- 1.3 Limitations of Use

2 DOSAGE AND ADMINISTRATION

- 2.1 Prior to Initiation of FARXIGA
- 2.2 Type 2 Diabetes Mellitus
- 2.3 Heart Failure
- 2.4 Patients with Renal Impairment

3 DOSAGE FORMS AND STRENGTHS

4 CONTRAINDICATIONS

5 WARNINGS AND PRECAUTIONS

- 5.1 Volume Depletion
- 5.2 Ketoacidosis in Patients with Diabetes Mellitus
- 5.3 Urosepsis and Pyelonephritis
- 5.4 Hypoglycemia with Concomitant Use with Insulin and Insulin Secretagogues
- 5.5 Necrotizing Fasciitis of the Perineum (Fournier's Gangrene)

- 5.6 Genital Mycotic Infections

6 ADVERSE REACTIONS

- 6.1 Clinical Trials Experience
- 6.2 Postmarketing Experience

7 DRUG INTERACTIONS

- 7.1 Positive Urine Glucose Test
- 7.2 Interference with 1,5-anhydroglucitol (1,5-AG) Assay

8 USE IN SPECIFIC POPULATIONS

- 8.1 Pregnancy
- 8.2 Lactation
- 8.4 Pediatric Use
- 8.5 Geriatric Use
- 8.6 Renal Impairment
- 8.7 Hepatic Impairment

10 OVERDOSAGE

11 DESCRIPTION

12 CLINICAL PHARMACOLOGY

- 12.1 Mechanism of Action

12.2 Pharmacodynamics

12.3 Pharmacokinetics

13 NONCLINICAL TOXICOLOGY

13.1 Carcinogenesis, Mutagenesis, Impairment of Fertility

14 CLINICAL STUDIES

14.1 Glycemic Control in Patients with Type 2 Diabetes Mellitus

14.2 Cardiovascular Outcomes in Patients with Type 2 Diabetes Mellitus

14.3 Heart Failure with Reduced Ejection Fraction

16 HOW SUPPLIED/STORAGE AND HANDLING

17 PATIENT COUNSELING INFORMATION

*Sections or subsections omitted from the full prescribing information are not listed.

FULL PRESCRIBING INFORMATION

1 INDICATIONS AND USAGE

1.1 Type 2 Diabetes Mellitus

FARXIGA (dapagliflozin) is indicated:

- as an adjunct to diet and exercise to improve glycemic control in adults with type 2 diabetes mellitus.
- to reduce the risk of hospitalization for heart failure in adults with type 2 diabetes mellitus and established cardiovascular disease (CVD) or multiple cardiovascular (CV) risk factors.

1.2 Heart Failure

FARXIGA is indicated to reduce the risk of cardiovascular death and hospitalization for heart failure in adults with heart failure (NYHA class II-IV) with reduced ejection fraction.

1.3 Limitations of Use

FARXIGA is not recommended for patients with type 1 diabetes mellitus or for the treatment of diabetic ketoacidosis.

2 DOSAGE AND ADMINISTRATION

2.1 Prior to Initiation of FARXIGA

Assess renal function prior to initiation of FARXIGA therapy and then as clinically indicated [*see Warnings and Precautions (5.1)*].

In patients with volume depletion, correct this condition prior to initiation of FARXIGA [*see Warnings and Precautions (5.1) and Use in Specific Populations (8.5, 8.6)*].

2.2 Type 2 Diabetes Mellitus

To improve glycemic control, the recommended starting dose of FARXIGA is 5 mg orally once daily, taken in the morning, with or without food. In patients tolerating FARXIGA 5 mg once daily who require additional glycemic control, the dose can be increased to 10 mg once daily.

To reduce the risk of hospitalization for heart failure in patients with type 2 diabetes mellitus and established CVD or multiple CV risk factors, the recommended dose of FARXIGA is 10 mg orally once daily.

2.3 Heart Failure

The recommended dose of FARXIGA is 10 mg orally once daily.

2.4 Patients with Renal Impairment

Table 1. FARXIGA Dosing Recommendations for Patients Based on Renal Function

Treatment/ Patient Population	Recommended Dosage based on eGFR (mL/min/1.73 m ² , CKD-EPI)			
	45 or above	30 to less than 45	less than 30	ESRD/Dialysis
Use for glycemic control in patients with T2DM	No dose adjustment	Not recommended	Contraindicated	
To reduce risk of hHF in patients with T2DM, <u>with</u> CVD or multiple CV risk factors	No dose adjustment	Insufficient data to support a dosing recommendation.		Contraindicated
To reduce risk of CV death and hHF in patients with HFrEF, <u>with or without</u> T2DM	No dose adjustment		Insufficient data to support a dosing recommendation.	Contraindicated

eGFR: Estimated glomerular filtration rate, CKD-EPI: Chronic kidney disease epidemiology collaboration equation, T2DM: Type 2 diabetes mellitus, hHF: hospitalization for heart failure, HFrEF: Heart failure with reduced ejection fraction, CVD: Cardiovascular disease, CV: Cardiovascular, ESRD: End Stage Renal Disease

3 DOSAGE FORMS AND STRENGTHS

- FARXIGA 5 mg tablets are yellow, biconvex, round, film-coated tablets with “5” engraved on one side and “1427” engraved on the other side.
- FARXIGA 10 mg tablets are yellow, biconvex, diamond-shaped, film-coated tablets with “10” engraved on one side and “1428” engraved on the other side.

4 CONTRAINDICATIONS

- History of a serious hypersensitivity reaction to FARXIGA, such as anaphylactic reactions or angioedema [see *Adverse Reactions (6.1)*].
- Patients who are being treated for glycemic control without established CVD or multiple CV risk factors with severe renal impairment, (eGFR less than 30 mL/min/1.73 m²) [see *Use in Specific Populations (8.6)*].
- Patients on dialysis [see *Use in Specific Populations (8.6)*].

5 WARNINGS AND PRECAUTIONS

5.1 Volume Depletion

FARXIGA can cause intravascular volume depletion which may sometimes manifest as symptomatic hypotension or acute transient changes in creatinine. There have been post-marketing reports of acute kidney injury, some requiring hospitalization and dialysis, in patients with type 2 diabetes mellitus receiving SGLT2 inhibitors, including FARXIGA. Patients with impaired renal function (eGFR less than 60 mL/min/1.73 m²), elderly patients, or patients on loop diuretics may be at increased risk for volume depletion or hypotension. Before initiating FARXIGA in patients with one or more of these characteristics, assess volume status and renal function. Monitor for signs and symptoms of hypotension, and renal function after initiating therapy.

5.2 Ketoacidosis in Patients with Diabetes Mellitus

Reports of ketoacidosis, a serious life-threatening condition requiring urgent hospitalization have been identified in patients with type 1 and type 2 diabetes mellitus receiving sodium-glucose cotransporter 2 (SGLT2) inhibitors, including FARXIGA [see *Adverse Reactions (6.1)*]. Fatal cases of ketoacidosis have been reported in patients taking FARXIGA. FARXIGA is not indicated for the treatment of patients with type 1 diabetes mellitus [see *Indications and Usage (1.3)*].

Patients treated with FARXIGA who present with signs and symptoms consistent with severe metabolic acidosis should be assessed for ketoacidosis regardless of presenting blood glucose levels as ketoacidosis associated with FARXIGA may be present even if blood glucose levels are less than 250 mg/dL. If ketoacidosis is suspected, FARXIGA should be discontinued, the patient should be evaluated, and prompt treatment should be instituted. Treatment of ketoacidosis may require insulin, fluid, and carbohydrate replacement.

In many of the postmarketing reports, and particularly in patients with type 1 diabetes, the presence of ketoacidosis was not immediately recognized, and the institution of treatment was delayed because the presenting blood glucose levels were below those typically expected for diabetic ketoacidosis (often less than 250 mg/dL). Signs and symptoms at presentation were consistent with dehydration and severe metabolic acidosis and included nausea, vomiting, abdominal pain, generalized malaise, and shortness of breath. In some but not all cases, factors predisposing to ketoacidosis, such as insulin dose reduction, acute febrile illness, reduced caloric intake, surgery, pancreatic disorders suggesting insulin deficiency (e.g., type 1 diabetes, history of pancreatitis or pancreatic surgery), and alcohol abuse were identified.

Before initiating FARXIGA, consider factors in the patient history that may predispose to ketoacidosis, including pancreatic insulin deficiency from any cause, caloric restriction, and alcohol abuse.

For patients who undergo scheduled surgery, consider temporarily discontinuing FARXIGA for at least 3 days prior to surgery [see *Clinical Pharmacology (12.2, 12.3)*].

Consider monitoring for ketoacidosis and temporarily discontinuing FARXIGA in other clinical situations known to predispose to ketoacidosis (e.g., prolonged fasting due to acute illness or post-surgery). Ensure risk factors for ketoacidosis are resolved prior to restarting FARXIGA.

Educate patients on the signs and symptoms of ketoacidosis and instruct patients to discontinue FARXIGA and seek medical attention immediately if signs and symptoms occur.

5.3 Urosepsis and Pyelonephritis

Serious urinary tract infections including urosepsis and pyelonephritis requiring hospitalization have been reported in patients receiving SGLT2 inhibitors, including FARXIGA. Treatment with SGLT2 inhibitors increases the risk for urinary tract infections. Evaluate patients for signs and symptoms of urinary tract infections and treat promptly, if indicated [see *Adverse Reactions (6)*].

5.4 Hypoglycemia with Concomitant Use with Insulin and Insulin Secretagogues

Insulin and insulin secretagogues are known to cause hypoglycemia. FARXIGA may increase the risk of hypoglycemia when combined with insulin or an insulin secretagogue [see *Adverse Reactions (6.1)*].

Therefore, a lower dose of insulin or insulin secretagogue may be required to minimize the risk of hypoglycemia when these agents are used in combination with FARXIGA.

5.5 Necrotizing Fasciitis of the Perineum (Fournier’s Gangrene)

Reports of necrotizing fasciitis of the perineum (Fournier’s Gangrene), a rare but serious and life-threatening necrotizing infection requiring urgent surgical intervention, have been identified in postmarketing surveillance in patients with diabetes mellitus receiving SGLT2 inhibitors, including FARXIGA. Cases have been reported in both females and males. Serious outcomes have included hospitalization, multiple surgeries, and death.

Patients treated with FARXIGA presenting with pain or tenderness, erythema, or swelling in the genital or perineal area, along with fever or malaise, should be assessed for necrotizing fasciitis. If suspected, start treatment immediately with broad-spectrum antibiotics and, if necessary, surgical debridement. Discontinue FARXIGA, closely monitor blood glucose levels, and provide appropriate alternative therapy for glycemic control.

5.6 Genital Mycotic Infections

FARXIGA increases the risk of genital mycotic infections. Patients with a history of genital mycotic infections were more likely to develop genital mycotic infections [see *Adverse Reactions (6.1)*]. Monitor and treat appropriately.

6 ADVERSE REACTIONS

The following important adverse reactions are described below and elsewhere in the labeling:

- Volume Depletion [see *Warnings and Precautions (5.1)*]
- Ketoacidosis in Patients with Diabetes Mellitus [see *Warnings and Precautions (5.2)*]
- Urosepsis and Pyelonephritis [see *Warnings and Precautions (5.3)*]
- Hypoglycemia with Concomitant Use with Insulin and Insulin Secretagogues [see *Warnings and Precautions (5.4)*]
- Necrotizing Fasciitis of the Perineum (Fournier’s Gangrene) [see *Warnings and Precautions (5.5)*]
- Genital Mycotic Infections [see *Warnings and Precautions (5.6)*]

6.1 Clinical Trials Experience

Because clinical trials are conducted under widely varying conditions, adverse reaction rates observed in the clinical trials of a drug cannot be directly compared to rates in the clinical trials of another drug and may not reflect the rates observed in clinical practice.

FARXIGA has been evaluated in clinical trials in patients with type 2 diabetes mellitus and in patients with heart failure. The overall safety profile of FARXIGA was consistent across the studied indications. Severe hypoglycemia and diabetic ketoacidosis (DKA) were observed only in patients with diabetes mellitus.

Clinical Trials in Patients with Type 2 Diabetes Mellitus

Pool of 12 Placebo-Controlled Studies for FARXIGA 5 and 10 mg for Glycemic Control

The data in Table 1 is derived from 12 glycemic control placebo-controlled studies in patients with type 2 diabetes mellitus ranging from 12 to 24 weeks. In 4 studies FARXIGA was used as monotherapy, and in 8 studies FARXIGA was used as add-on to background antidiabetic therapy or as combination therapy with metformin [see *Clinical Studies (14.1)*].

These data reflect exposure of 2338 patients to FARXIGA with a mean exposure duration of 21 weeks. Patients received placebo (N=1393), FARXIGA 5 mg (N=1145), or FARXIGA 10 mg (N=1193) once daily. The mean age of the population was 55 years and 2% were older than 75 years of age. Fifty percent (50%) of the population were male; 81% were White, 14% were Asian, and 3% were Black or African American. At baseline, the population had diabetes for an average of 6 years, had a mean hemoglobin A1c (HbA1c) of 8.3%, and 21% had established microvascular complications of diabetes. Baseline renal function was normal or mildly impaired in 92% of patients and moderately impaired in 8% of patients (mean eGFR 86 mL/min/1.73 m²).

Table 2 shows common adverse reactions associated with the use of FARXIGA. These adverse reactions were not present at baseline, occurred more commonly on FARXIGA than on placebo, and occurred in at least 2% of patients treated with either FARXIGA 5 mg or FARXIGA 10 mg.

Table 2: Adverse Reactions in Placebo-Controlled Studies of Glycemic Control Reported in ≥2% of Patients Treated with FARXIGA

Adverse Reaction	% of Patients		
	Pool of 12 Placebo-Controlled Studies		
	Placebo N=1393	FARXIGA 5 mg N=1145	FARXIGA 10 mg N=1193
Female genital mycotic infections*	1.5	8.4	6.9
Nasopharyngitis	6.2	6.6	6.3
Urinary tract infections†	3.7	5.7	4.3
Back pain	3.2	3.1	4.2
Increased urination‡	1.7	2.9	3.8
Male genital mycotic infections§	0.3	2.8	2.7
Nausea	2.4	2.8	2.5
Influenza	2.3	2.7	2.3

Table 2: Adverse Reactions in Placebo-Controlled Studies of Glycemic Control Reported in ≥2% of Patients Treated with FARXIGA

Adverse Reaction	% of Patients		
	Pool of 12 Placebo-Controlled Studies		
	Placebo N=1393	FARXIGA 5 mg N=1145	FARXIGA 10 mg N=1193
Dyslipidemia	1.5	2.1	2.5
Constipation	1.5	2.2	1.9
Discomfort with urination	0.7	1.6	2.1
Pain in extremity	1.4	2.0	1.7

- * Genital mycotic infections include the following adverse reactions, listed in order of frequency reported for females: vulvovaginal mycotic infection, vaginal infection, vulvovaginal candidiasis, vulvovaginitis, genital infection, genital candidiasis, fungal genital infection, vulvitis, genitourinary tract infection, vulval abscess, and vaginitis bacterial. (N for females: Placebo=677, FARXIGA 5 mg=581, FARXIGA 10 mg=598).
- † Urinary tract infections include the following adverse reactions, listed in order of frequency reported: urinary tract infection, cystitis, *Escherichia* urinary tract infection, genitourinary tract infection, pyelonephritis, trigonitis, urethritis, kidney infection, and prostatitis.
- ‡ Increased urination includes the following adverse reactions, listed in order of frequency reported: pollakiuria, polyuria, and urine output increased.
- § Genital mycotic infections include the following adverse reactions, listed in order of frequency reported for males: balanitis, fungal genital infection, balanitis candida, genital candidiasis, genital infection male, penile infection, balanoposthitis, balanoposthitis infective, genital infection, and posthitis. (N for males: Placebo=716, FARXIGA 5 mg=564, FARXIGA 10 mg=595).

Pool of 13 Placebo-Controlled Studies for FARXIGA 10 mg for Glycemic Control

FARXIGA 10 mg was also evaluated in a larger glycemic control placebo-controlled study pool in patients with type 2 diabetes mellitus. This pool combined 13 placebo-controlled studies, including 3 monotherapy studies, 9 add-on to background antidiabetic therapy studies, and an initial combination with metformin study. Across these 13 studies, 2360 patients were treated once daily with FARXIGA 10 mg for a mean duration of exposure of 22 weeks. The mean age of the population was 59 years and 4% were older than 75 years. Fifty-eight percent (58%) of the population were male; 84% were White, 9% were Asian, and 3% were Black or African American. At baseline, the population had diabetes for an average of 9 years, had a mean HbA1c of 8.2%, and 30% had established microvascular disease. Baseline renal function was normal or mildly impaired in 88% of patients and moderately impaired in 11% of patients (mean eGFR 82 mL/min/1.73 m²).

Volume Depletion

FARXIGA causes an osmotic diuresis, which may lead to a reduction in intravascular volume. Adverse reactions related to volume depletion (including reports of dehydration, hypovolemia, orthostatic

hypotension, or hypotension) in patients with type 2 diabetes mellitus for the 12-study and 13-study, short-term, placebo-controlled pools and for the DECLARE study are shown in Table 3 [see [Warnings and Precautions \(5.1\)](#)].

Table 3: Adverse Reactions Related to Volume Depletion* in Clinical Studies in Patients with Type 2 Diabetes Mellitus with FARXIGA

	Pool of 12 Placebo-Controlled Studies			Pool of 13 Placebo-Controlled Studies		DECLARE Study	
	Placebo	FARXIGA 5 mg	FARXIGA 10 mg	Placebo	FARXIGA 10 mg	Placebo	FARXIGA 10 mg
Overall population N (%)	N=1393 5 (0.4%)	N=1145 7 (0.6%)	N=1193 9 (0.8%)	N=2295 17 (0.7%)	N=2360 27 (1.1%)	N=8569 207 (2.4%)	N=8574 213 (2.5%)
Patient Subgroup n (%)							
Patients on loop diuretics	n=55 1 (1.8%)	n=40 0	n=31 3 (9.7%)	n=267 4 (1.5%)	n=236 6 (2.5%)	n=934 57 (6.1%)	n=866 57 (6.6%)
Patients with moderate renal impairment with eGFR \geq 30 and <60 mL/min/1.73 m ²	n=107 2 (1.9%)	n=107 1 (0.9%)	n=89 1 (1.1%)	n=268 4 (1.5%)	n=265 5 (1.9%)	n=658 30 (4.6%)	n=604 35 (5.8%)
Patients \geq 65 years of age	n=276 1 (0.4%)	n=216 1 (0.5%)	n=204 3 (1.5%)	n=711 6 (0.8%)	n=665 11 (1.7%)	n=3950 121 (3.1%)	n=3948 117 (3.0%)

* Volume depletion includes reports of dehydration, hypovolemia, orthostatic hypotension, or hypotension.

Hypoglycemia

The frequency of hypoglycemia by study in patients with type 2 diabetes mellitus [see [Clinical Studies \(14.1\)](#)] is shown in Table 4. Hypoglycemia was more frequent when FARXIGA was added to sulfonylurea or insulin [see [Warnings and Precautions \(5.4\)](#)].

Table 4: Incidence of Severe Hypoglycemia* and Hypoglycemia with Glucose < 54 mg/dL[†] in Controlled Glycemic Control Clinical Studies in Patients with Type 2 Diabetes Mellitus

	Placebo/Active Control	FARXIGA 5 mg	FARXIGA 10 mg
Monotherapy (24 weeks)	N=75	N=64	N=70
Severe [n (%)]	0	0	0
Glucose <54 mg/dL [n (%)]	0	0	0
Add-on to Metformin (24 weeks)	N=137	N=137	N=135
Severe [n (%)]	0	0	0
Glucose <54 mg/dL [n (%)]	0	0	0
Add-on to Glimpiride (24 weeks)	N=146	N=145	N=151
Severe [n (%)]	0	0	0
Glucose <54 mg/dL [n (%)]	1 (0.7)	3 (2.1)	5 (3.3)

Table 4: Incidence of Severe Hypoglycemia* and Hypoglycemia with Glucose < 54 mg/dL† in Controlled Glycemic Control Clinical Studies in Patients with Type 2 Diabetes Mellitus

	Placebo/Active Control	FARXIGA 5 mg	FARXIGA 10 mg
Add-on to Metformin and a Sulfonylurea (24 Weeks)	N=109	-	N=109
Severe [n (%)]	0	-	0
Glucose <54 mg/dL [n (%)]	3 (2.8)	-	7 (6.4)
Add-on to Pioglitazone (24 weeks)	N=139	N=141	N=140
Severe [n (%)]	0	0	0
Glucose <54 mg/dL [n (%)]	0	1 (0.7)	0
Add-on to DPP4 inhibitor (24 weeks)	N=226	-	N=225
Severe [n (%)]	0	-	1 (0.4)
Glucose <54 mg/dL [n (%)]	1 (0.4)	-	1 (0.4)
Add-on to Insulin with or without other OADs‡ (24 weeks)	N=197	N=212	N=196
Severe [n (%)]	1 (0.5)	2 (0.9)	2 (1.0)
Glucose <54 mg/dL [n (%)]	43 (21.8)	55 (25.9)	45 (23.0)

* Severe episodes of hypoglycemia were defined as episodes of severe impairment in consciousness or behavior, requiring external (third party) assistance, and with prompt recovery after intervention regardless of glucose level.

† Episodes of hypoglycemia with glucose <54 mg/dL (3 mmol/L) were defined as reported episodes of hypoglycemia meeting the glucose criteria that did not also qualify as a severe episode.

‡ OAD = oral antidiabetic therapy.

In the DECLARE study [see *Clinical Studies (14.2)*], severe events of hypoglycemia were reported in 58 (0.7%) out of 8574 patients treated with FARXIGA and 83 (1.0%) out of 8569 patients treated with placebo.

Genital Mycotic Infections

In the glycemic control trials, genital mycotic infections were more frequent with FARXIGA treatment. Genital mycotic infections were reported in 0.9% of patients on placebo, 5.7% on FARXIGA 5 mg, and 4.8% on FARXIGA 10 mg, in the 12-study placebo-controlled pool. Discontinuation from study due to genital infection occurred in 0% of placebo-treated patients and 0.2% of patients treated with FARXIGA 10 mg. Infections were more frequently reported in females than in males (see Table 1). The most frequently reported genital mycotic infections were vulvovaginal mycotic infections in females and balanitis in males. Patients with a history of genital mycotic infections were more likely to have a genital mycotic infection during the study than those with no prior history (10.0%, 23.1%, and 25.0% versus 0.8%, 5.9%, and 5.0% on placebo, FARXIGA 5 mg, and FARXIGA 10 mg, respectively). In the DECLARE study [see *Clinical Studies (14.2)*], serious genital mycotic infections were reported in <0.1% of patients treated with FARXIGA and <0.1% of patients treated with placebo. Genital mycotic infections that caused study drug discontinuation were reported in 0.9% of patients treated with FARXIGA and <0.1% of patients treated with placebo.

Hypersensitivity Reactions

Hypersensitivity reactions (e.g., angioedema, urticaria, hypersensitivity) were reported with FARXIGA treatment. In glycemic control studies, serious anaphylactic reactions and severe cutaneous adverse reactions and angioedema were reported in 0.2% of comparator-treated patients and 0.3% of FARXIGA-treated patients. If hypersensitivity reactions occur, discontinue use of FARXIGA; treat per standard of care and monitor until signs and symptoms resolve.

Ketoacidosis in Patients with Diabetes Mellitus

In the DECLARE study [see [Clinical Studies \(14.2\)](#)], events of diabetic ketoacidosis (DKA) were reported in 27 out of 8574 patients in the FARXIGA-treated group and 12 out of 8569 patients in the placebo group. The events were evenly distributed over the study period.

Laboratory Tests

Increases in Serum Creatinine and Decreases in eGFR

Initiation of SGLT2 inhibitors, including FARXIGA causes a small increase in serum creatinine and decrease in eGFR. In patients with normal or mildly impaired renal function at baseline, these changes in serum creatinine and eGFR generally occur within weeks of starting therapy and then stabilize. Increases that do not fit this pattern should prompt further evaluation to exclude the possibility of acute kidney injury [see [Warnings and Precautions \(5.1\)](#)]. The acute effect on eGFR reverses after treatment discontinuation, suggesting acute hemodynamic changes may play a role in the renal function changes observed with FARXIGA.

Increase in Hematocrit

In the pool of 13 placebo-controlled studies of glycemic control, increases from baseline in mean hematocrit values were observed in FARXIGA-treated patients starting at Week 1 and continuing up to Week 16, when the maximum mean difference from baseline was observed. At Week 24, the mean changes from baseline in hematocrit were -0.33% in the placebo group and 2.30% in the FARXIGA 10 mg group. By Week 24, hematocrit values >55% were reported in 0.4% of placebo-treated patients and 1.3% of FARXIGA 10 mg-treated patients.

Increase in Low-Density Lipoprotein Cholesterol

In the pool of 13 placebo-controlled studies of glycemic control, changes from baseline in mean lipid values were reported in FARXIGA-treated patients compared to placebo-treated patients. Mean percent changes from baseline at Week 24 were 0.0% versus 2.5% for total cholesterol, and -1.0% versus 2.9% for LDL cholesterol in the placebo and FARXIGA 10 mg groups, respectively. In the DECLARE study [see [Clinical Studies \(14.2\)](#)], mean changes from baseline after 4 years were 0.4 mg/dL versus -4.1 mg/dL for total cholesterol, and -2.5 mg/dL versus -4.4 mg/dL for LDL cholesterol, in FARXIGA-treated and the placebo groups, respectively.

Decrease in Serum Bicarbonate

In a study of concomitant therapy of FARXIGA 10 mg with exenatide extended-release (on a background of metformin), four patients (1.7%) on concomitant therapy had a serum bicarbonate value of less than or

equal to 13 mEq/L compared to one each (0.4%) in the FARXIGA and exenatide-extended release treatment groups [see [Warnings and Precautions \(5.2\)](#)].

DAPA-HF Heart Failure Study

No new adverse reactions were identified in the DAPA-HF heart failure study.

6.2 Postmarketing Experience

Additional adverse reactions have been identified during postapproval use of FARXIGA in patients with diabetes mellitus. Because these reactions are reported voluntarily from a population of uncertain size, it is generally not possible to reliably estimate their frequency or establish a causal relationship to drug exposure.

- Ketoacidosis
- Acute Kidney Injury
- Urosepsis and Pyelonephritis
- Necrotizing Fasciitis of the Perineum (Fournier's Gangrene)
- Rash

7 DRUG INTERACTIONS

7.1 Positive Urine Glucose Test

Monitoring glycemic control with urine glucose tests is not recommended in patients taking SGLT2 inhibitors as SGLT2 inhibitors increase urinary glucose excretion and will lead to positive urine glucose tests. Use alternative methods to monitor glycemic control.

7.2 Interference with 1,5-anhydroglucitol (1,5-AG) Assay

Monitoring glycemic control with 1,5-AG assay is not recommended as measurements of 1,5-AG are unreliable in assessing glycemic control in patients taking SGLT2 inhibitors. Use alternative methods to monitor glycemic control.

8 USE IN SPECIFIC POPULATIONS

8.1 Pregnancy

Risk Summary

Based on animal data showing adverse renal effects, FARXIGA is not recommended during the second and third trimesters of pregnancy.

Limited data with FARXIGA in pregnant women are not sufficient to determine drug-associated risk for major birth defects or miscarriage. There are risks to the mother and fetus associated with poorly controlled diabetes and untreated heart failure in pregnancy (see [Clinical Considerations](#)).

In animal studies, adverse renal pelvic and tubule dilatations, that were not fully reversible, were observed in rats when dapagliflozin was administered during a period of renal development corresponding to the

late second and third trimesters of human pregnancy, at all doses tested; the lowest of which provided an exposure 15-times the 10 mg clinical dose (*see Data*).

The estimated background risk of major birth defects is 6 to 10% in women with pre-gestational diabetes with a HbA1c greater than 7% and has been reported to be as high as 20 to 25% in women with HbA1c greater than 10%. The estimated background risk of miscarriage for the indicated population is unknown. In the U.S. general population, the estimated background risk of major birth defects and miscarriage in clinically recognized pregnancies is 2 to 4% and 15 to 20%, respectively.

Clinical Considerations

Disease-associated maternal and/or embryofetal risk

Poorly controlled diabetes in pregnancy increases the maternal risk for diabetic ketoacidosis, preeclampsia, spontaneous abortions, preterm delivery and delivery complications. Poorly controlled diabetes increases the fetal risk for major birth defects, stillbirth, and macrosomia related morbidity.

Data

Animal Data

Dapagliflozin dosed directly to juvenile rats from postnatal day (PND) 21 until PND 90 at doses of 1, 15, or 75 mg/kg/day, increased kidney weights and increased the incidence of renal pelvic and tubular dilatations at all dose levels. Exposure at the lowest dose tested was 15-times the 10 mg clinical dose (based on AUC). The renal pelvic and tubular dilatations observed in juvenile animals did not fully reverse within a 1-month recovery period.

In a prenatal and postnatal development study, dapagliflozin was administered to maternal rats from gestation day 6 through lactation day 21 at doses of 1, 15, or 75 mg/kg/day, and pups were indirectly exposed *in utero* and throughout lactation. Increased incidence or severity of renal pelvic dilatation was observed in 21-day-old pups offspring of treated dams at 75 mg/kg/day (maternal and pup dapagliflozin exposures were 1415-times and 137-times, respectively, the human values at the 10 mg clinical dose, based on AUC). Dose-related reductions in pup body weights were observed at greater or equal to 29-times the 10 mg clinical dose (based on AUC). No adverse effects on developmental endpoints were noted at 1 mg/kg/day (19-times the 10 mg clinical dose, based on AUC). These outcomes occurred with drug exposure during periods of renal development in rats that corresponds to the late second and third trimester of human development.

In embryofetal development studies in rats and rabbits, dapagliflozin was administered throughout organogenesis, corresponding to the first trimester of human pregnancy. In rats, dapagliflozin was neither embryoethal nor teratogenic at doses up to 75 mg/kg/day (1441-times the 10 mg clinical dose, based on AUC). Dose related effects on the rat fetus (structural abnormalities and reduced body weight) occurred only at higher dosages, equal to or greater than 150 mg/kg (more than 2344-times the 10 mg clinical dose, based on AUC), which were associated with maternal toxicity. No developmental toxicities were observed in rabbits at doses up to 180 mg/kg/day (1191-times the 10 mg clinical dose, based on AUC).

8.2 Lactation

Risk Summary

There is no information regarding the presence of dapagliflozin in human milk, the effects on the breastfed infant, or the effects on milk production. Dapagliflozin is present in the milk of lactating rats (*see Data*). However, due to species specific differences in lactation physiology, the clinical relevance of these data are not clear. Since human kidney maturation occurs *in utero* and during the first 2 years of life when lactational exposure may occur, there may be risk to the developing human kidney.

Because of the potential for serious adverse reactions in breastfed infants, advise women that use of FARXIGA is not recommended while breastfeeding.

Data

Dapagliflozin was present in rat milk at a milk/plasma ratio of 0.49, indicating that dapagliflozin and its metabolites are transferred into milk at a concentration that is approximately 50% of that in maternal plasma. Juvenile rats directly exposed to dapagliflozin showed risk to the developing kidney (renal pelvic and tubular dilatations) during maturation.

8.4 Pediatric Use

Safety and effectiveness of FARXIGA in pediatric patients under 18 years of age have not been established.

8.5 Geriatric Use

No FARXIGA dosage change is recommended based on age.

A total of 1424 (24%) of the 5936 FARXIGA-treated patients were 65 years and older and 207 (3.5%) patients were 75 years and older in a pool of 21 double-blind, controlled, clinical studies assessing the efficacy of FARXIGA in improving glycemic control in type 2 diabetes mellitus. After controlling for level of renal function (eGFR), efficacy was similar for patients under age 65 years and those 65 years and older. In patients ≥ 65 years of age, a higher proportion of patients treated with FARXIGA for glycemic control had adverse reactions of hypotension [*see Warnings and Precautions (5.1) and Adverse Reactions (6.1)*].

In the DAPA-HF study, 2714 (57%) out of 4744 patients with HF_rEF were older than 65 years. Safety and efficacy were similar for patients age 65 years and younger and those older than 65.

8.6 Renal Impairment

FARXIGA was evaluated in two glycemic control studies that included patients with type 2 diabetes mellitus with moderate renal impairment (an eGFR of 45 to less than 60 mL/min/1.73 m² [*see Clinical Studies (14.1)*], and an eGFR of 30 to less than 60 mL/min/1.73 m², respectively). The safety profile of FARXIGA in the study of patients with an eGFR of 45 to less than 60 mL/min/1.73 m² was similar to the general population of patients with type 2 diabetes mellitus. Although patients in the FARXIGA arm had reduction in eGFR compared to the placebo arm, eGFR generally returned towards baseline after treatment discontinuation. Patients with diabetes and renal impairment using FARXIGA may also be

more likely to experience hypotension and may be at higher risk for acute kidney injury. In the study of patients with an eGFR 30 to less than 60 mL/min/1.73 m², 13 patients receiving FARXIGA experienced bone fractures compared to none receiving placebo.

Use of FARXIGA for glycemic control in patients without established CV disease or CV risk factors is not recommended when eGFR is less than 45 mL/min/1.73 m² [see [Dosage and Administration \(2.4\)](#)] and is contraindicated in patients with severe renal impairment (eGFR less than 30 mL/min/1.73 m²) [see [Contraindications \(4\)](#)].

In the DAPA-HF study [see [Clinical Studies \(14.3\)](#)] that included patients with eGFR equal to or above 30 mL/min/1.73 m², there were 1926 (41%) patients with eGFR below 60 mL/min/1.73 m² and 719 (15%) with eGFR below 45 mL/min/1.73 m². No overall differences in safety or efficacy were seen in these patients compared to patients with normal renal function. No dose adjustment is recommended for HFrEF patients with eGFR 30 mL/min/1.73 m² and above [see [Dosage and Administration \(2.4\)](#)].

8.7 Hepatic Impairment

No dose adjustment is recommended for patients with mild, moderate, or severe hepatic impairment. However, the benefit-risk for the use of dapagliflozin in patients with severe hepatic impairment should be individually assessed since the safety and efficacy of dapagliflozin have not been specifically studied in this population [see [Clinical Pharmacology \(12.3\)](#)].

10 OVERDOSAGE

There were no reports of overdose during the clinical development program for FARXIGA.

In the event of an overdose, contact the Poison Control Center. It is also reasonable to employ supportive measures as dictated by the patient's clinical status. The removal of dapagliflozin by hemodialysis has not been studied.

11 DESCRIPTION

Dapagliflozin is described chemically as D-glucitol, 1,5-anhydro-1-C-[4-chloro-3-[(4-ethoxyphenyl)methyl]phenyl]-, (1S)-, compounded with (2S)-1,2-propanediol, hydrate (1:1:1). The empirical formula is C₂₁H₂₅ClO₆•C₃H₈O₂•H₂O and the molecular weight is 502.98. The structural formula is:

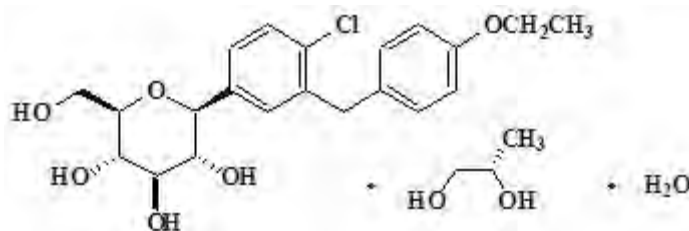

FARXIGA is available as a film-coated tablet for oral administration containing the equivalent of 5 mg dapagliflozin as dapagliflozin propanediol or the equivalent of 10 mg dapagliflozin as dapagliflozin propanediol, and the following inactive ingredients: microcrystalline cellulose, anhydrous lactose,

crospovidone, silicon dioxide, and magnesium stearate. In addition, the film coating contains the following inactive ingredients: polyvinyl alcohol, titanium dioxide, polyethylene glycol, talc, and yellow iron oxide.

12 CLINICAL PHARMACOLOGY

12.1 Mechanism of Action

Sodium-glucose cotransporter 2 (SGLT2), expressed in the proximal renal tubules, is responsible for the majority of the reabsorption of filtered glucose from the tubular lumen. Dapagliflozin is an inhibitor of SGLT2. By inhibiting SGLT2, dapagliflozin reduces reabsorption of filtered glucose and lowers the renal threshold for glucose, and thereby increases urinary glucose excretion. Dapagliflozin also reduces sodium reabsorption and increases the delivery of sodium to the distal tubule. This may influence several physiological functions including, but not restricted to, lowering both pre- and afterload of the heart and downregulation of sympathetic activity.

12.2 Pharmacodynamics

General

Increases in the amount of glucose excreted in the urine were observed in healthy subjects and in patients with type 2 diabetes mellitus following the administration of dapagliflozin (see Figure 1). Dapagliflozin doses of 5 or 10 mg per day in patients with type 2 diabetes mellitus for 12 weeks resulted in excretion of approximately 70 grams of glucose in the urine per day at Week 12. A near maximum glucose excretion was observed at the dapagliflozin daily dose of 20 mg. This urinary glucose excretion with dapagliflozin also results in increases in urinary volume [*see Adverse Reactions (6.1)*]. After discontinuation of dapagliflozin, on average, the elevation in urinary glucose excretion approaches baseline by about 3 days for the 10 mg dose.

Figure 1: Scatter Plot and Fitted Line of Change from Baseline in 24-Hour Urinary Glucose Amount versus Dapagliflozin Dose in Healthy Subjects and Subjects with Type 2 Diabetes Mellitus (T2DM) (Semi-Log Plot)

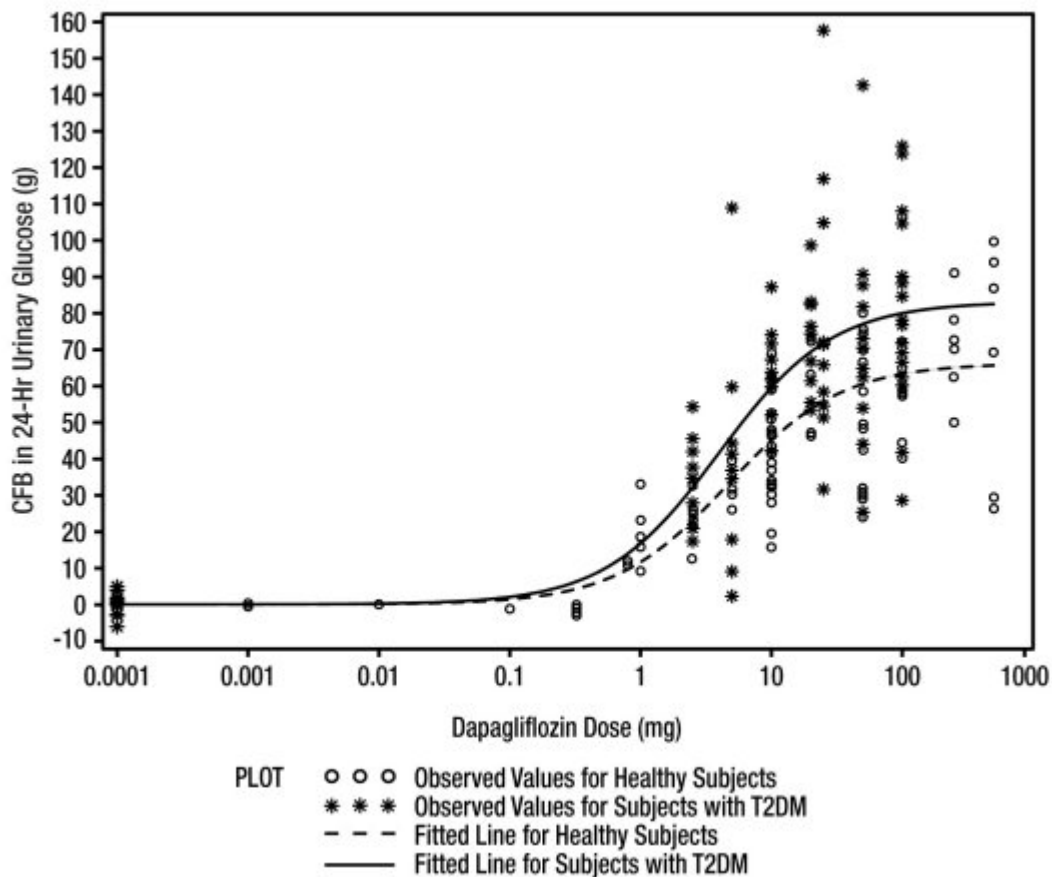

Cardiac Electrophysiology

Dapagliflozin was not associated with clinically meaningful prolongation of QTc interval at daily doses up to 150 mg (15-times the recommended maximum dose) in a study of healthy subjects. In addition, no clinically meaningful effect on QTc interval was observed following single doses of up to 500 mg (50-times the recommended maximum dose) of dapagliflozin in healthy subjects.

12.3 Pharmacokinetics

Absorption

Following oral administration of dapagliflozin, the maximum plasma concentration (C_{max}) is usually attained within 2 hours under fasting state. The C_{max} and AUC values increase dose proportionally with increase in dapagliflozin dose in the therapeutic dose range. The absolute oral bioavailability of dapagliflozin following the administration of a 10 mg dose is 78%. Administration of dapagliflozin with a high-fat meal decreases its C_{max} by up to 50% and prolongs T_{max} by approximately 1 hour, but does not

alter AUC as compared with the fasted state. These changes are not considered to be clinically meaningful and dapagliflozin can be administered with or without food.

Distribution

Dapagliflozin is approximately 91% protein bound. Protein binding is not altered in patients with renal or hepatic impairment.

Metabolism

The metabolism of dapagliflozin is primarily mediated by UGT1A9; CYP-mediated metabolism is a minor clearance pathway in humans. Dapagliflozin is extensively metabolized, primarily to yield dapagliflozin 3-O-glucuronide, which is an inactive metabolite. Dapagliflozin 3-O-glucuronide accounted for 61% of a 50 mg [¹⁴C]-dapagliflozin dose and is the predominant drug-related component in human plasma.

Elimination

Dapagliflozin and related metabolites are primarily eliminated via the renal pathway. Following a single 50 mg dose of [¹⁴C]-dapagliflozin, 75% and 21% total radioactivity is excreted in urine and feces, respectively. In urine, less than 2% of the dose is excreted as parent drug. In feces, approximately 15% of the dose is excreted as parent drug. The mean plasma terminal half-life ($t_{1/2}$) for dapagliflozin is approximately 12.9 hours following a single oral dose of FARXIGA 10 mg.

Specific Populations

Renal Impairment

At steady-state (20 mg once daily dapagliflozin for 7 days), patients with type 2 diabetes with mild, moderate, or severe renal impairment (as determined by eGFR) had geometric mean systemic exposures of dapagliflozin that were 45%, 2.04-fold, and 3.03-fold higher, respectively, as compared to patients with type 2 diabetes mellitus with normal renal function. Higher systemic exposure of dapagliflozin in patients with type 2 diabetes mellitus with renal impairment did not result in a correspondingly higher 24-hour urinary glucose excretion. The steady-state 24-hour urinary glucose excretion in patients with type 2 diabetes mellitus and mild, moderate, and severe renal impairment was 42%, 80%, and 90% lower, respectively, than in patients with type 2 diabetes mellitus with normal renal function. The impact of hemodialysis on dapagliflozin exposure is not known [see *Dosage and Administration* (2.4), *Warnings and Precautions* (5.1), *Use in Specific Populations* (8.6), and *Clinical Studies* (14)].

Hepatic Impairment

In subjects with mild and moderate hepatic impairment (Child-Pugh classes A and B), mean C_{max} and AUC of dapagliflozin were up to 12% and 36% higher, respectively, as compared to healthy matched control subjects following single-dose administration of 10 mg dapagliflozin. These differences were not considered to be clinically meaningful. In patients with severe hepatic impairment (Child-Pugh class C), mean C_{max} and AUC of dapagliflozin were up to 40% and 67% higher, respectively, as compared to healthy matched controls [see *Use in Specific Populations* (8.7)].

Effects of Age, Gender, Race, and Body Weight on Pharmacokinetics

Based on a population pharmacokinetic analysis, age, gender, race, and body weight do not have a clinically meaningful effect on the pharmacokinetics of dapagliflozin and thus, no dose adjustment is recommended.

Pediatric

Pharmacokinetics in the pediatric population has not been studied.

Drug Interactions

In Vitro Assessment of Drug Interactions

In *in vitro* studies, dapagliflozin and dapagliflozin 3-O-glucuronide neither inhibited CYP 1A2, 2C9, 2C19, 2D6, or 3A4, nor induced CYP 1A2, 2B6, or 3A4. Dapagliflozin is a weak substrate of the P-glycoprotein (P-gp) active transporter, and dapagliflozin 3-O-glucuronide is a substrate for the OAT3 active transporter. Dapagliflozin or dapagliflozin 3-O-glucuronide did not meaningfully inhibit P-gp, OCT2, OAT1, or OAT3 active transporters. Overall, dapagliflozin is unlikely to affect the pharmacokinetics of concurrently administered medications that are P-gp, OCT2, OAT1, or OAT3 substrates.

Effects of Other Drugs on Dapagliflozin

Table 5 shows the effect of coadministered drugs on the pharmacokinetics of dapagliflozin. No dose adjustments are recommended for dapagliflozin.

Table 5: Effects of Coadministered Drugs on Dapagliflozin Systemic Exposure

Coadministered Drug (Dose Regimen)*	Dapagliflozin (Dose Regimen)*	Effect on Dapagliflozin Exposure (% Change [90% CI])	
		C _{max}	AUC [†]
No dosing adjustments required for the following:			
Oral Antidiabetic Agents			
Metformin (1000 mg)	20 mg	↔	↔
Pioglitazone (45 mg)	50 mg	↔	↔
Sitagliptin (100 mg)	20 mg	↔	↔
Glimepiride (4 mg)	20 mg	↔	↔
Voglibose (0.2 mg three times daily)	10 mg	↔	↔
Other Medications			
Hydrochlorothiazide (25 mg)	50 mg	↔	↔
Bumetanide (1 mg)	10 mg once daily for 7 days	↔	↔
Valsartan (320 mg)	20 mg	↓12% [↓3%, ↓20%]	↔
Simvastatin (40 mg)	20 mg	↔	↔
Anti-infective Agent			
Rifampin (600 mg once daily for 6 days)	10 mg	↓7% [↓22%, ↑11%]	↓22% [↓27%, ↓17%]
Nonsteroidal Anti-inflammatory Agent			
Mefenamic Acid (loading dose of 500 mg followed by 14 doses of 250 mg every 6 hours)	10 mg	↑13% [↑3%, ↑24%]	↑51% [↑44%, ↑58%]

↔ = no change (geometric mean ratio of test: reference within 0.80 to 1.25); ↓ or ↑ = parameter was lower or higher, respectively, with coadministration compared to dapagliflozin administered alone (geometric mean ratio of test: reference was lower than 0.80 or higher than 1.25)

* Single dose unless otherwise noted.

† AUC = AUC(INF) for drugs given as single dose and AUC = AUC(TAU) for drugs given in multiple doses.

Effects of Dapagliflozin on Other Drugs

Table 6 shows the effect of dapagliflozin on other coadministered drugs. Dapagliflozin did not meaningfully affect the pharmacokinetics of the coadministered drugs.

Table 6: Effects of Dapagliflozin on the Systemic Exposures of Coadministered Drugs

Coadministered Drug (Dose Regimen)*	Dapagliflozin (Dose Regimen)*	Effect on Coadministered Drug Exposure (% Change [90% CI])	
		C _{max}	AUC [†]
No dosing adjustments required for the following:			
Oral Antidiabetic Agents			
Metformin (1000 mg)	20 mg	↔	↔

Table 6: Effects of Dapagliflozin on the Systemic Exposures of Coadministered Drugs

Coadministered Drug (Dose Regimen)*	Dapagliflozin (Dose Regimen)*	Effect on Coadministered Drug Exposure (% Change [90% CI])	
		C _{max}	AUC [†]
Pioglitazone (45 mg)	50 mg	↓7% [↓25%, ↑15%]	↔
Sitagliptin (100 mg)	20 mg	↔	↔
Glimepiride (4 mg)	20 mg	↔	↑13% [0%, ↑29%]
Other Medications			
Hydrochlorothiazide (25 mg)	50 mg	↔	↔
Bumetanide (1 mg)	10 mg once daily for 7 days	↑13% [↓2%, ↑31%]	↑13% [↓1%, ↑30%]
Valsartan (320 mg)	20 mg	↓6% [↓24%, ↑16%]	↑5% [↓15%, ↑29%]
Simvastatin (40 mg)	20 mg	↔	↑19%
Digoxin (0.25 mg)	20 mg loading dose then 10 mg once daily for 7 days	↔	↔
Warfarin (25 mg)	20 mg loading dose then 10 mg once daily for 7 days	↔	↔

↔ = no change (geometric mean ratio of test: reference within 0.80 to 1.25); ↓ or ↑ = parameter was lower or higher, respectively, with coadministration compared to the other medicine administered alone (geometric mean ratio of test: reference was lower than 0.80 or higher than 1.25).

* Single dose unless otherwise noted.

† AUC = AUC(INF) for drugs given as single dose and AUC = AUC(TAU) for drugs given in multiple doses.

13 NONCLINICAL TOXICOLOGY

13.1 Carcinogenesis, Mutagenesis, Impairment of Fertility

Dapagliflozin did not induce tumors in either mice or rats at any of the doses evaluated in 2-year carcinogenicity studies. Oral doses in mice consisted of 5, 15, and 40 mg/kg/day in males and 2, 10, and 20 mg/kg/day in females, and oral doses in rats were 0.5, 2, and 10 mg/kg/day for both males and females. The highest doses evaluated in mice were approximately 72-times (males) and 105-times (females) the clinical dose of 10 mg per day, based on AUC exposure. In rats, the highest dose was approximately 131-times (males) and 186-times (females) the clinical dose of 10 mg per day, based on AUC exposure.

Dapagliflozin was negative in the Ames mutagenicity assay and was positive in a series of *in vitro* clastogenicity assays in the presence of S9 activation and at concentrations greater than or equal to 100 µg/mL. Dapagliflozin was negative for clastogenicity in a series of *in vivo* studies evaluating micronuclei or DNA repair in rats at exposure multiples greater than 2100-times the clinical dose.

There was no carcinogenicity or mutagenicity signal in animal studies, suggesting that dapagliflozin does not represent a genotoxic risk to humans.

Dapagliflozin had no effects on mating, fertility, or early embryonic development in treated male or female rats at exposure multiples less than or equal to 1708-times and 998-times the maximum recommended human dose in males and females, respectively.

14 CLINICAL STUDIES

14.1 Glycemic Control in Patients with Type 2 Diabetes Mellitus

Overview of Clinical Studies of FARXIGA for Type 2 Diabetes Mellitus

FARXIGA has been studied as monotherapy, in combination with metformin, pioglitazone, sulfonylurea (glimepiride), sitagliptin (with or without metformin), metformin plus a sulfonylurea, or insulin (with or without other oral antidiabetic therapy), compared to a sulfonylurea (glipizide), and in combination with a GLP-1 receptor agonist (exenatide extended-release) added-on to metformin. FARXIGA has also been studied in patients with type 2 diabetes mellitus and moderate renal impairment.

Treatment with FARXIGA as monotherapy and in combination with metformin, glimepiride, pioglitazone, sitagliptin, or insulin produced statistically significant improvements in mean change from baseline at Week 24 in HbA1c compared to control. Reductions in HbA1c were seen across subgroups including gender, age, race, duration of disease, and baseline body mass index (BMI).

Monotherapy

A total of 840 treatment-naive patients with inadequately controlled type 2 diabetes mellitus participated in 2 placebo-controlled studies to evaluate the safety and efficacy of monotherapy with FARXIGA.

In 1 monotherapy study, a total of 558 treatment-naive patients with inadequately controlled diabetes participated in a 24-week study (NCT00528372). Following a 2-week diet and exercise placebo lead-in period, 485 patients with HbA1c $\geq 7\%$ and $\leq 10\%$ were randomized to FARXIGA 5 mg or FARXIGA 10 mg once daily in either the morning (QAM, main cohort) or evening (QPM), or placebo.

At Week 24, treatment with FARXIGA 10 mg QAM provided significant improvements in HbA1c and the fasting plasma glucose (FPG) compared with placebo (see Table 7).

Table 7: Results at Week 24 (LOCF*) in a Placebo-Controlled Study of FARXIGA Monotherapy in Patients with Type 2 Diabetes Mellitus (Main Cohort AM Doses)

Efficacy Parameter	FARXIGA 10 mg N=70 [†]	FARXIGA 5 mg N=64 [†]	Placebo N=75 [†]
HbA1c (%)			
Baseline (mean)	8.0	7.8	7.8
Change from baseline (adjusted mean [‡])	-0.9	-0.8	-0.2
Difference from placebo (adjusted mean [‡]) (95% CI)	-0.7 [§] (-1.0, -0.4)	-0.5 (-0.8, -0.2)	
Percent of patients achieving HbA1c <7% adjusted for baseline	50.8% [¶]	44.2% [¶]	31.6%
FPG (mg/dL)			
Baseline (mean)	166.6	157.2	159.9
Change from baseline (adjusted mean [‡])	-28.8	-24.1	-4.1

Table 7: Results at Week 24 (LOCF*) in a Placebo-Controlled Study of FARXIGA Monotherapy in Patients with Type 2 Diabetes Mellitus (Main Cohort AM Doses)

Efficacy Parameter	FARXIGA 10 mg N=70 [†]	FARXIGA 5 mg N=64 [†]	Placebo N=75 [†]
Difference from placebo (adjusted mean [‡]) (95% CI)	-24.7 [§] (-35.7, -13.6)	-19.9 (-31.3, -8.5)	

* LOCF: last observation (prior to rescue for rescued patients) carried forward.

† All randomized patients who took at least one dose of double-blind study medication during the short-term double-blind period.

‡ Least squares mean adjusted for baseline value.

§ p-value <0.0001 versus placebo. Sensitivity analyses yielded smaller estimates of treatment difference with placebo.

¶ Not evaluated for statistical significance as a result of the sequential testing procedure for the secondary endpoints.

Initial Combination Therapy with Metformin XR

A total of 1236 treatment-naive patients with inadequately controlled type 2 diabetes mellitus (HbA1c $\geq 7.5\%$ and $\leq 12\%$) participated in 2 active-controlled studies of 24-week duration to evaluate initial therapy with FARXIGA 5 mg (NCT00643851) or 10 mg (NCT00859898) in combination with metformin extended-release (XR) formulation.

In 1 study, 638 patients randomized to 1 of 3 treatment arms following a 1-week lead-in period received: FARXIGA 10 mg plus metformin XR (up to 2000 mg per day), FARXIGA 10 mg plus placebo, or metformin XR (up to 2000 mg per day) plus placebo. Metformin XR dose was up-titrated weekly in 500 mg increments, as tolerated, with a median dose achieved of 2000 mg.

The combination treatment of FARXIGA 10 mg plus metformin XR provided statistically significant improvements in HbA1c and FPG compared with either of the monotherapy treatments and statistically significant reduction in body weight compared with metformin XR alone (see Table 8 and Figure 2). FARXIGA 10 mg as monotherapy also provided statistically significant improvements in FPG and statistically significant reduction in body weight compared with metformin alone and was noninferior to metformin XR monotherapy in lowering HbA1c.

Table 8: Results at Week 24 (LOCF*) in an Active-Controlled Study of FARXIGA Initial Combination Therapy with Metformin XR

Efficacy Parameter	FARXIGA 10 mg + Metformin XR N=211†	FARXIGA 10 mg N=219†	Metformin XR N=208†
HbA1c (%)			
Baseline (mean)	9.1	9.0	9.0
Change from baseline (adjusted mean‡)	-2.0	-1.5	-1.4
Difference from FARXIGA (adjusted mean‡) (95% CI)	-0.5§ (-0.7, -0.3)		
Difference from metformin XR (adjusted mean‡) (95% CI)	-0.5§ (-0.8, -0.3)	0.0¶ (-0.2, 0.2)	
Percent of patients achieving HbA1c <7% adjusted for baseline	46.6%#	31.7%	35.2%
FPG (mg/dL)			
Baseline (mean)	189.6	197.5	189.9
Change from baseline (adjusted mean‡)	-60.4	-46.4	-34.8
Difference from FARXIGA (adjusted mean‡) (95% CI)	-13.9§ (-20.9, -7.0)		
Difference from metformin XR (adjusted mean‡) (95% CI)	-25.5§ (-32.6, -18.5)	-11.6# (-18.6, -4.6)	
Body Weight (kg)			
Baseline (mean)	88.6	88.5	87.2
Change from baseline (adjusted mean‡)	-3.3	-2.7	-1.4
Difference from metformin XR (adjusted mean‡) (95% CI)	-2.0§ (-2.6, -1.3)	-1.4§ (-2.0, -0.7)	

* LOCF: last observation (prior to rescue for rescued patients) carried forward.

† All randomized patients who took at least one dose of double-blind study medication during the short-term double-blind period.

‡ Least squares mean adjusted for baseline value.

§ p-value <0.0001.

¶ Noninferior versus metformin XR.

p-value <0.05.

Figure 2: Adjusted Mean Change from Baseline Over Time in HbA1c (%) in a 24-Week Active-Controlled Study of FARXIGA Initial Combination Therapy with Metformin XR

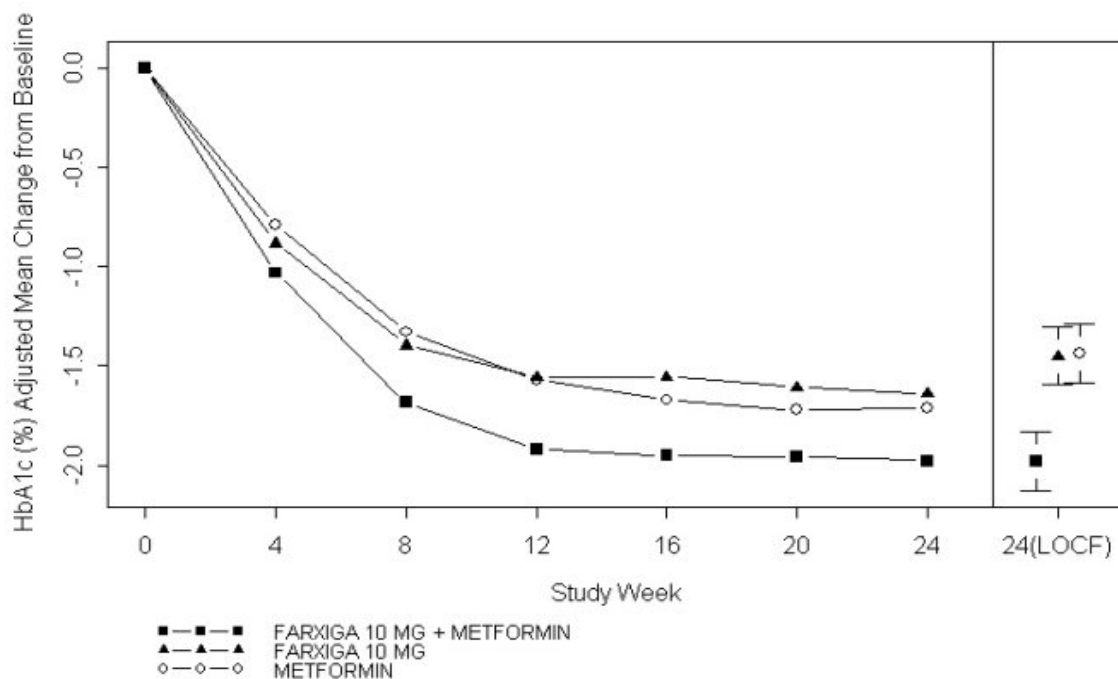

Left side graph: Values for adjusted mean change from baseline based on a longitudinal repeated measures model, including randomized subjects who completed the study with both baseline and Week 24 HbA1c values without rescue. Right side graph for Week 24 (LOCF): Values for adjusted mean change from baseline and 95% CIs based on an ANCOVA model, including randomized subjects with a baseline and at least one post baseline HbA1c before rescue.

In a second study, 603 patients were randomized to 1 of 3 treatment arms following a 1-week lead-in period: FARXIGA 5 mg plus metformin XR (up to 2000 mg per day), FARXIGA 5 mg plus placebo, or metformin XR (up to 2000 mg per day) plus placebo. Metformin XR dose was up-titrated weekly in 500 mg increments, as tolerated, with a median dose achieved of 2000 mg.

The combination treatment of FARXIGA 5 mg plus metformin XR provided statistically significant improvements in HbA1c and FPG compared with either of the monotherapy treatments and statistically significant reduction in body weight compared with metformin XR alone (see Table 9).

Table 9: Results at Week 24 (LOCF*) in an Active-Controlled Study of FARXIGA Initial Combination Therapy with Metformin XR

Efficacy Parameter	FARXIGA 5 mg + Metformin XR N=194 [†]	FARXIGA 5 mg N=203 [†]	Metformin XR N=201 [†]
HbA1c (%)			
Baseline (mean)	9.2	9.1	9.1
Change from baseline (adjusted mean [‡])	-2.1	-1.2	-1.4

Table 9: Results at Week 24 (LOCF*) in an Active-Controlled Study of FARXIGA Initial Combination Therapy with Metformin XR

Efficacy Parameter	FARXIGA 5 mg + Metformin XR N=194†	FARXIGA 5 mg N=203†	Metformin XR N=201†
Difference from FARXIGA (adjusted mean‡) (95% CI)	-0.9§ (-1.1, -0.6)		
Difference from metformin XR (adjusted mean‡) (95% CI)	-0.7§ (-0.9, -0.5)		
Percent of patients achieving HbA1c <7% adjusted for baseline	52.4%¶	22.5%	34.6%
FPG (mg/dL)			
Baseline (mean)	193.4	190.8	196.7
Change from baseline (adjusted mean‡)	-61.0	-42.0	-33.6
Difference from FARXIGA (adjusted mean‡) (95% CI)	-19.1§ (-26.7, -11.4)		
Difference from metformin XR (adjusted mean‡) (95% CI)	-27.5§ (-35.1, -19.8)		
Body Weight (kg)			
Baseline (mean)	84.2	86.2	85.8
Change from baseline (adjusted mean‡)	-2.7	-2.6	-1.3
Difference from metformin XR (adjusted mean‡) (95% CI)	-1.4§ (-2.0, -0.7)		

* LOCF: last observation (prior to rescue for rescued patients) carried forward.

† All randomized patients who took at least one dose of double-blind study medication during the short-term double-blind period.

‡ Least squares mean adjusted for baseline value.

§ p-value <0.0001.

¶ p-value <0.05.

Add-On to Metformin

A total of 546 patients with type 2 diabetes mellitus with inadequate glycemic control (HbA1c \geq 7% and \leq 10%) participated in a 24-week, placebo-controlled study to evaluate FARXIGA in combination with metformin (NCT00528879). Patients on metformin at a dose of at least 1500 mg per day were randomized after completing a 2-week, single-blind, placebo lead-in period. Following the lead-in period, eligible patients were randomized to FARXIGA 5 mg, FARXIGA 10 mg, or placebo in addition to their current dose of metformin.

As add-on treatment to metformin, FARXIGA 10 mg provided statistically significant improvements in HbA1c and FPG, and statistically significant reduction in body weight compared with placebo at Week 24 (see Table 10 and Figure 3). Statistically significant ($p < 0.05$ for both doses) mean changes from baseline in systolic blood pressure relative to placebo plus metformin were -4.5 mmHg and -5.3 mmHg with FARXIGA 5 mg and 10 mg plus metformin, respectively.

Table 10: Results of a 24-Week (LOCF*) Placebo-Controlled Study of FARXIGA in Add-On Combination with Metformin

Efficacy Parameter	FARXIGA 10 mg + Metformin N=135†	FARXIGA 5 mg + Metformin N=137†	Placebo + Metformin N=137†
HbA1c (%)			
Baseline (mean)	7.9	8.2	8.1
Change from baseline (adjusted mean‡)	-0.8	-0.7	-0.3
Difference from placebo (adjusted mean‡) (95% CI)	-0.5§ (-0.7, -0.3)	-0.4§ (-0.6, -0.2)	
Percent of patients achieving HbA1c <7% adjusted for baseline	40.6%¶	37.5%¶	25.9%
FPG (mg/dL)			
Baseline (mean)	156.0	169.2	165.6
Change from baseline at Week 24 (adjusted mean‡)	-23.5	-21.5	-6.0
Difference from placebo (adjusted mean‡) (95% CI)	-17.5§ (-25.0, -10.0)	-15.5§ (-22.9, -8.1)	
Change from baseline at Week 1 (adjusted mean‡)	-16.5§ (N=115)	-12.0§ (N=121)	1.2 (N=126)
Body Weight (kg)			
Baseline (mean)	86.3	84.7	87.7
Change from baseline (adjusted mean‡)	-2.9	-3.0	-0.9
Difference from placebo (adjusted mean‡) (95% CI)	-2.0§ (-2.6, -1.3)	-2.2§ (-2.8, -1.5)	

* LOCF: last observation (prior to rescue for rescued patients) carried forward.

† All randomized patients who took at least one dose of double-blind study medication during the short-term double-blind period.

‡ Least squares mean adjusted for baseline value.

§ p-value <0.0001 versus placebo + metformin.

¶ p-value <0.05 versus placebo + metformin.

Figure 3: Adjusted Mean Change from Baseline Over Time in HbA1c (%) in a 24-Week Placebo-Controlled Study of FARXIGA in Combination with Metformin

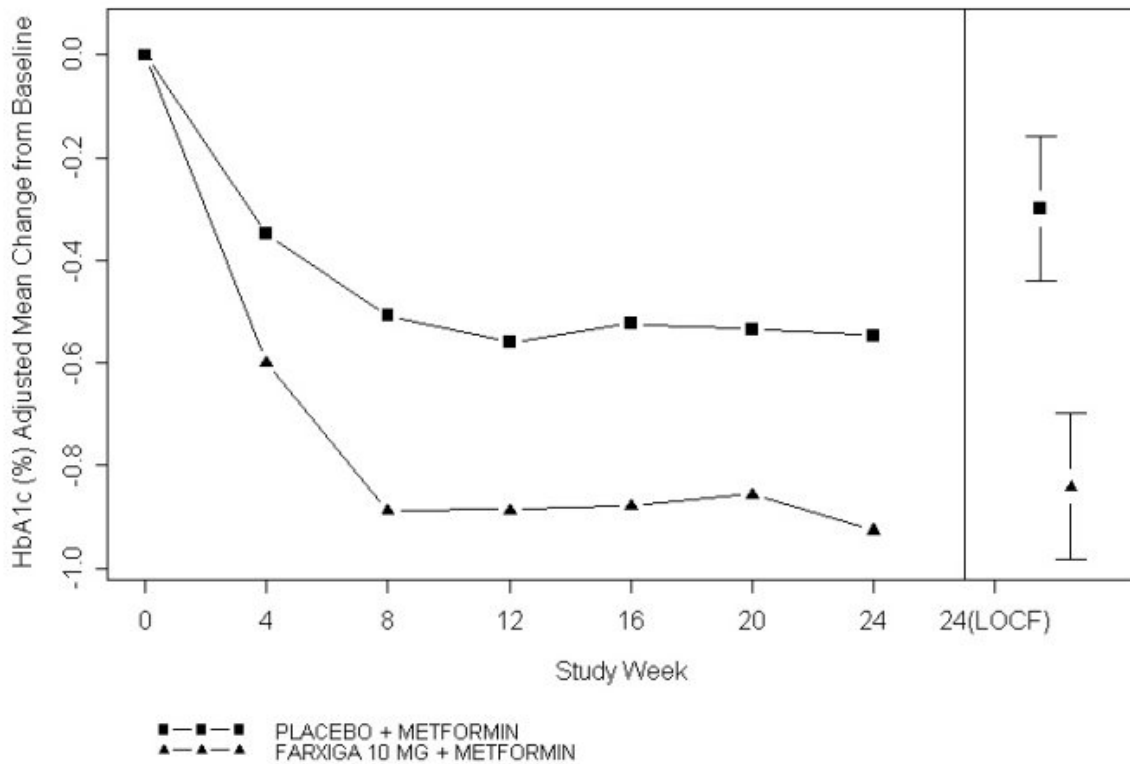

Left side graph: Values for adjusted mean change from baseline based on a longitudinal repeated measures model, including randomized subjects who completed Short-Term Period with both baseline and Week 24 HbA1c values without rescue. Right side graph for Week 24 (LOCF): Values for adjusted mean change from baseline and 95% CIs based on an ANCOVA model, including randomized subjects with a baseline and at least one post baseline HbA1c before rescue.

Active Glipizide-Controlled Study Add-On to Metformin

A total of 816 patients with type 2 diabetes mellitus with inadequate glycemic control (HbA1c >6.5% and ≤10%) were randomized in a 52-week, glipizide-controlled, noninferiority study to evaluate FARXIGA as add-on therapy to metformin (NCT00660907). Patients on metformin at a dose of at least 1500 mg per day were randomized following a 2-week placebo lead-in period to glipizide or dapagliflozin (5 mg or 2.5 mg, respectively) and were up-titrated over 18 weeks to optimal glycemic effect (FPG <110 mg/dL, <6.1 mmol/L) or to the highest dose level (up to glipizide 20 mg and FARXIGA 10 mg) as tolerated by patients. Thereafter, doses were kept constant, except for down-titration to prevent hypoglycemia.

At the end of the titration period, 87% of patients treated with FARXIGA had been titrated to the maximum study dose (10 mg) versus 73% treated with glipizide (20 mg). FARXIGA led to a similar mean reduction in HbA1c from baseline at Week 52 (LOCF), compared with glipizide, thus demonstrating noninferiority (see Table 11). FARXIGA treatment led to a statistically significant mean reduction in body weight from baseline at Week 52 (LOCF) compared with a mean increase in body weight in the glipizide group. Statistically significant ($p < 0.0001$) mean change from baseline in systolic blood pressure relative to glipizide plus metformin was -5.0 mmHg with FARXIGA plus metformin.

Table 11: Results at Week 52 (LOCF*) in an Active-Controlled Study Comparing FARXIGA to Glipizide as Add-On to Metformin

Efficacy Parameter	FARXIGA + Metformin N=400†	Glipizide + Metformin N=401†
HbA1c (%)		
Baseline (mean)	7.7	7.7
Change from baseline (adjusted mean‡)	-0.5	-0.5
Difference from glipizide + metformin (adjusted mean‡) (95% CI)	0.0§ (-0.1, 0.1)	
Body Weight (kg)		
Baseline (mean)	88.4	87.6
Change from baseline (adjusted mean‡)	-3.2	1.4
Difference from glipizide + metformin (adjusted mean‡) (95% CI)	-4.7¶ (-5.1, -4.2)	

* LOCF: last observation carried forward.

† Randomized and treated patients with baseline and at least 1 postbaseline efficacy measurement.

‡ Least squares mean adjusted for baseline value.

§ Noninferior to glipizide + metformin.

¶ p-value <0.0001.

Add-On Combination Therapy with Other Antidiabetic Agents

Add-On Combination Therapy with a Sulfonylurea

A total of 597 patients with type 2 diabetes mellitus and inadequate glycemic control (HbA1c \geq 7% and \leq 10%) were randomized in this 24-week, placebo-controlled study to evaluate FARXIGA in combination with glimepiride (a sulfonylurea) (NCT00680745).

Patients on at least half the maximum recommended dose of glimepiride as monotherapy (4 mg) for at least 8 weeks lead-in were randomized to FARXIGA 5 mg, FARXIGA 10 mg, or placebo in addition to glimepiride 4 mg per day. Down-titration of glimepiride to 2 mg or 0 mg was allowed for hypoglycemia during the treatment period; no up-titration of glimepiride was allowed.

In combination with glimepiride, FARXIGA 10 mg provided statistically significant improvement in HbA1c, FPG, and 2-hour PPG, and statistically significant reduction in body weight compared with placebo plus glimepiride at Week 24 (see Table 12). Statistically significant ($p < 0.05$ for both doses) mean changes from baseline in systolic blood pressure relative to placebo plus glimepiride were -2.8 mmHg and -3.8 mmHg with FARXIGA 5 mg and 10 mg plus glimepiride, respectively.

Add-on Combination Therapy with Metformin and a Sulfonylurea

A total of 218 patients with type 2 diabetes mellitus and inadequate glycemic control (HbA1c \geq 7% and \leq 10.5%) participated in a 24-week, placebo-controlled study to evaluate FARXIGA in combination with metformin and a sulfonylurea (NCT01392677). Patients on a stable dose of metformin (immediate- or extended-release formulations) \geq 1500 mg/day plus maximum tolerated dose, which must be at least half the maximum dose, of a sulfonylurea for at least 8 weeks prior to enrollment were randomized after an 8-week placebo lead-in period to FARXIGA 10 mg or placebo. Dose-titration of FARXIGA or metformin

was not permitted during the 24-week treatment period. Down-titration of the sulfonylurea was permitted to prevent hypoglycemia, but no up-titration was permitted. As add-on treatment to combined metformin and a sulfonylurea, treatment with FARXIGA 10 mg provided statistically significant improvements in HbA1c and FPG and statistically significant reduction in body weight compared with placebo at Week 24 (Table 12). A statistically significant ($p < 0.05$) mean change from baseline in systolic blood pressure relative to placebo in combination with metformin and a sulfonylurea was -3.8 mmHg with FARXIGA 10 mg in combination with metformin and a sulfonylurea at Week 8.

Add-On Combination Therapy with a Thiazolidinedione

A total of 420 patients with type 2 diabetes mellitus with inadequate glycemic control ($\text{HbA1c} \geq 7\%$ and $\leq 10.5\%$) participated in a 24-week, placebo-controlled study to evaluate FARXIGA in combination with pioglitazone (a thiazolidinedione [TZD]) alone (NCT00683878). Patients on a stable dose of pioglitazone of 45 mg per day (or 30 mg per day, if 45 mg per day was not tolerated) for 12 weeks were randomized after a 2-week lead-in period to 5 or 10 mg of FARXIGA or placebo in addition to their current dose of pioglitazone. Dose titration of FARXIGA or pioglitazone was not permitted during the study.

In combination with pioglitazone, treatment with FARXIGA 10 mg provided statistically significant improvements in HbA1c, 2-hour PPG, FPG, the proportion of patients achieving $\text{HbA1c} < 7\%$, and a statistically significant reduction in body weight compared with the placebo plus pioglitazone treatment groups (see Table 12) at Week 24. A statistically significant ($p < 0.05$) mean change from baseline in systolic blood pressure relative to placebo in combination with pioglitazone was -4.5 mmHg with FARXIGA 10 mg in combination with pioglitazone.

Add-On Combination Therapy with a DPP4 Inhibitor

A total of 452 patients with type 2 diabetes mellitus who were drug naive, or who were treated at entry with metformin or a DPP4 inhibitor alone or in combination, and had inadequate glycemic control ($\text{HbA1c} \geq 7.0\%$ and $\leq 10.0\%$ at randomization), participated in a 24-week, placebo-controlled study to evaluate FARXIGA in combination with sitagliptin (a DPP4 inhibitor) with or without metformin (NCT00984867).

Eligible patients were stratified based on the presence or absence of background metformin (≥ 1500 mg per day), and within each stratum were randomized to either FARXIGA 10 mg plus sitagliptin 100 mg once daily, or placebo plus sitagliptin 100 mg once daily. Endpoints were tested for FARXIGA 10 mg versus placebo for the total study group (sitagliptin with and without metformin) and for each stratum (sitagliptin alone or sitagliptin with metformin). Thirty-seven percent (37%) of patients were drug naive, 32% were on metformin alone, 13% were on a DPP4 inhibitor alone, and 18% were on a DPP4 inhibitor plus metformin. Dose titration of FARXIGA, sitagliptin, or metformin was not permitted during the study.

In combination with sitagliptin (with or without metformin), FARXIGA 10 mg provided statistically significant improvements in HbA1c, FPG, and a statistically significant reduction in body weight compared with the placebo plus sitagliptin (with or without metformin) group at Week 24 (see Table 12). These improvements were also seen in the stratum of patients who received FARXIGA 10 mg plus sitagliptin alone (placebo-corrected mean change for HbA1c -0.56%; $n=110$) compared with placebo plus sitagliptin alone ($n=111$), and the stratum of patients who received FARXIGA 10 mg plus sitagliptin and

metformin (placebo-corrected mean change for HbA1c -0.40 ; $n=113$) compared with placebo plus sitagliptin with metformin ($n=113$).

Add-On Combination Therapy with Insulin

A total of 808 patients with type 2 diabetes mellitus who had inadequate glycemic control (HbA1c $\geq 7.5\%$ and $\leq 10.5\%$) were randomized in a 24-week, placebo-controlled study to evaluate FARXIGA as add-on therapy to insulin (NCT00673231). Patients on a stable insulin regimen, with a mean dose of at least 30 IU of injectable insulin per day, for a period of at least 8 weeks prior to enrollment and on a maximum of 2 oral antidiabetic medications (OADs), including metformin, were randomized after completing a 2-week enrollment period to receive either FARXIGA 5 mg, FARXIGA 10 mg, or placebo in addition to their current dose of insulin and other OADs, if applicable. Patients were stratified according to the presence or absence of background OADs. Up- or down-titration of insulin was only permitted during the treatment phase in patients who failed to meet specific glycemic goals. Dose modifications of blinded study medication or OAD(s) were not allowed during the treatment phase, with the exception of decreasing OAD(s) where there were concerns over hypoglycemia after cessation of insulin therapy.

In this study, 50% of patients were on insulin monotherapy at baseline, while 50% were on 1 or 2 OADs in addition to insulin. At Week 24, FARXIGA 10 mg dose provided statistically significant improvement in HbA1c and reduction in mean insulin dose, and a statistically significant reduction in body weight compared with placebo in combination with insulin, with or without up to 2 OADs (see Table 12); the effect of FARXIGA on HbA1c was similar in patients treated with insulin alone and patients treated with insulin plus OAD. Statistically significant ($p<0.05$) mean change from baseline in systolic blood pressure relative to placebo in combination with insulin was -3.0 mmHg with FARXIGA 10 mg in combination with insulin.

At Week 24, FARXIGA 5 mg (-5.7 IU, difference from placebo) and 10 mg (-6.2 IU, difference from placebo) once daily resulted in a statistically significant reduction in mean daily insulin dose ($p<0.0001$ for both doses) compared to placebo in combination with insulin, and a statistically significantly higher proportion of patients on FARXIGA 10 mg (19.6%) reduced their insulin dose by at least 10% compared to placebo (11.0%).

Table 12: Results of 24-Week (LOCF*) Placebo-Controlled Studies of FARXIGA in Combination with Antidiabetic Agents

Efficacy Parameter	FARXIGA 10 mg	FARXIGA 5 mg	Placebo
In Combination with Sulfonylurea (Glimepiride)			
Intent-to-Treat Population	N=151[†]	N=142[†]	N=145[†]
HbA1c (%)			
Baseline (mean)	8.1	8.1	8.2
Change from baseline (adjusted mean [‡])	-0.8	-0.6	-0.1
Difference from placebo (adjusted mean [‡]) (95% CI)	-0.7^{\S} ($-0.9, -0.5$)	-0.5^{\S} ($-0.7, -0.3$)	
Percent of patients achieving HbA1c $<7\%$ adjusted for baseline	31.7% [§]	30.3% [§]	13.0%
FPG (mg/dL)			
Baseline (mean)	172.4	174.5	172.7

Table 12: Results of 24-Week (LOCF*) Placebo-Controlled Studies of FARXIGA in Combination with Antidiabetic Agents

Efficacy Parameter	FARXIGA 10 mg	FARXIGA 5 mg	Placebo
Change from baseline (adjusted mean [‡])	-28.5	-21.2	-2.0
Difference from placebo (adjusted mean [‡]) (95% CI)	-26.5 [§] (-33.5, -19.5)	-19.3 [§] (-26.3, -12.2)	
2-hour PPG[¶] (mg/dL)			
Baseline (mean)	329.6	322.8	324.1
Change from baseline (adjusted mean [‡])	-60.6	-54.5	-11.5
Difference from placebo (adjusted mean [‡]) (95% CI)	-49.1 [§] (-64.1, -34.1)	-43.0 [§] (-58.4, -27.5)	
Body Weight (kg)			
Baseline (mean)	80.6	81.0	80.9
Change from baseline (adjusted mean [‡])	-2.3	-1.6	-0.7
Difference from placebo (adjusted mean [‡]) (95% CI)	-1.5 [§] (-2.2, -0.9)	-0.8 [§] (-1.5, -0.2)	
In Combination with Metformin and a Sulfonylurea			
Intent-to-Treat Population	N=108[†]	-	N=108[†]
HbA1c (%)			
Baseline (mean)	8.08	-	8.24
Change from baseline (adjusted mean ^{‡#})	-0.86	-	-0.17
Difference from placebo (adjusted mean ^{‡#}) (95% CI)	-0.69 [§] (-0.89, -0.49)	-	
Percent of patients achieving HbA1c <7% adjusted for baseline	31.8% [§]	-	11.1%
FPG (mg/dL)			
Baseline (mean)	167.4	-	180.3
Change from baseline (adjusted mean [‡])	-34.2	-	-0.8
Difference from placebo (adjusted mean [‡]) (95% CI)	-33.5 [§] (-43.1, -23.8)	-	
Body Weight (kg)			
Baseline (mean)	88.57	-	90.07
Change from baseline (adjusted mean [‡])	-2.65	-	-0.58
Difference from placebo (adjusted mean [‡]) (95% CI)	-2.07 [§] (-2.79, -1.35)	-	
In Combination with Thiazolidinedione (Pioglitazone)			
Intent-to-Treat Population	N=140^b	N=141^b	N=139^b
HbA1c (%)			
Baseline (mean)	8.4	8.4	8.3
Change from baseline (adjusted mean [‡])	-1.0	-0.8	-0.4
Difference from placebo (adjusted mean [‡]) (95% CI)	-0.6 [§] (-0.8, -0.3)	-0.4 [§] (-0.6, -0.2)	
Percent of patients achieving HbA1c <7% adjusted for baseline	38.8% ^b	32.5% ^b	22.4%
FPG (mg/dL)			
Baseline (mean)	164.9	168.3	160.7
Change from baseline (adjusted mean [‡])	-29.6	-24.9	-5.5

Table 12: Results of 24-Week (LOCF*) Placebo-Controlled Studies of FARXIGA in Combination with Antidiabetic Agents

Efficacy Parameter	FARXIGA 10 mg	FARXIGA 5 mg	Placebo
Difference from placebo (adjusted mean [‡]) (95% CI)	-24.1 [§] (-32.2, -16.1)	-19.5 [§] (-27.5, -11.4)	
2-hour PPG[†] (mg/dL)			
Baseline (mean)	308.0	284.8	293.6
Change from baseline (adjusted mean [‡])	-67.5	-65.1	-14.1
Difference from placebo (adjusted mean [‡]) (95% CI)	-53.3 [§] (-71.1, -35.6)	-51.0 [§] (-68.7, -33.2)	
Body Weight (kg)			
Baseline (mean)	84.8	87.8	86.4
Change from baseline (adjusted mean [‡])	-0.1	0.1	1.6
Difference from placebo (adjusted mean [‡]) (95% CI)	-1.8 [§] (-2.6, -1.0)	-1.6 [§] (-2.3, -0.8)	
In Combination with DPP4 Inhibitor (Sitagliptin) with or without Metformin			
Intent-to-Treat Population	N=223[†]	-	N=224[†]
HbA1c (%)			
Baseline (mean)	7.90	-	7.97
Change from baseline (adjusted mean [‡])	-0.45	-	0.04
Difference from placebo (adjusted mean [‡]) (95% CI)	-0.48 [§] (-0.62, -0.34)	-	
Patients with HbA1c decrease $\geq 0.7\%$ (adjusted percent)	35.4%	-	16.6%
FPG (mg/dL)			
Baseline (mean)	161.7	-	163.1
Change from baseline at Week 24 (adjusted mean [‡])	-24.1	-	3.8
Difference from placebo (adjusted mean [‡]) (95% CI)	-27.9 [§] (-34.5, -21.4)	-	
Body Weight (kg)			
Baseline (mean)	91.02	-	89.23
Change from baseline (adjusted mean [‡])	-2.14	-	-0.26
Difference from placebo (adjusted mean [‡]) (95% CI)	-1.89 [§] (-2.37, -1.40)	-	
In Combination with Insulin with or without up to 2 Oral Antidiabetic Therapies			
Intent-to-Treat Population	N=194[†]	N=211[†]	N=193[†]
HbA1c (%)			
Baseline (mean)	8.6	8.6	8.5
Change from baseline (adjusted mean [‡])	-0.9	-0.8	-0.3
Difference from placebo (adjusted mean [‡]) (95% CI)	-0.6 [§] (-0.7, -0.5)	-0.5 [§] (-0.7, -0.4)	
FPG (mg/dL)			
Baseline (mean)	173.7	NT ^à	170.0
Change from baseline (adjusted mean [‡])	-21.7	NT ^à	3.3
Difference from placebo (adjusted mean [‡]) (95% CI)	-25.0 [§] (-34.3, -15.8)	NT ^à	
Body Weight (kg)			

Table 12: Results of 24-Week (LOCF*) Placebo-Controlled Studies of FARXIGA in Combination with Antidiabetic Agents

Efficacy Parameter	FARXIGA 10 mg	FARXIGA 5 mg	Placebo
Baseline (mean)	94.6	93.2	94.2
Change from baseline (adjusted mean [†])	-1.7	-1.0	0.0
Difference from placebo (adjusted mean [‡]) (95% CI)	-1.7 [§] (-2.2, -1.2)	-1.0 [§] (-1.5, -0.5)	

* LOCF: last observation (prior to rescue for rescued patients) carried forward.

† Randomized and treated patients with baseline and at least 1 post baseline efficacy measurement.

‡ Least squares mean adjusted for baseline value based on an ANCOVA model.

§ p-value <0.0001 versus placebo.

¶ 2-hour PPG level as a response to a 75-gram oral glucose tolerance test (OGTT).

Least squares mean adjusted for baseline value based on a longitudinal repeated measures model.

Ⓟ All randomized patients who took at least one dose of double-blind study medication during the short-term, double-blind period.

β p-value <0.05 versus placebo.

à NT: Not formally tested because of failing to achieve a statistically significant difference in an endpoint that was earlier in the testing sequence.

Combination Therapy with Exenatide-Extended Release as Add-On to Metformin

A total of 694 adult patients with type 2 diabetes mellitus and inadequate glycemic control (HbA1c \geq 8.0 and \leq 12.0%) on metformin, were evaluated in a 28-week double-blind, active-controlled study to compare FARXIGA in combination with exenatide extended-release (a GLP-1 receptor agonist) to FARXIGA alone and exenatide extended-release alone, as add-on to metformin (NCT02229396). Patients on metformin at a dose of at least 1,500 mg per day were randomized following a 1-week placebo lead-in period to receive either FARXIGA 10 mg once daily (QD) in combination with exenatide extended-release 2 mg once weekly (QW), FARXIGA 10 mg QD, or exenatide extended-release 2 mg QW.

At Week 28, FARXIGA in combination with exenatide extended-release provided statistically significantly greater reductions in HbA1c (-1.77%) compared to FARXIGA alone (-1.32%, $p=0.001$) and exenatide extended-release alone (-1.42%, $p=0.012$). FARXIGA in combination with exenatide extended-release provided statistically significantly greater reductions in FPG (-57.35 mg/dL) compared to FARXIGA alone (-44.72 mg/dL, $p=0.006$) and exenatide extended-release alone (-40.53, $p <0.001$).

Use in Patients with Type 2 Diabetes Mellitus and Moderate Renal Impairment

FARXIGA was assessed in two placebo-controlled studies of patients with type 2 diabetes mellitus and moderate renal impairment.

Patients with type 2 diabetes mellitus and an eGFR between 45 to less than 60 mL/min/1.73 m² inadequately controlled on current diabetes therapy participated in a 24-week, double-blind, placebo-controlled clinical study (NCT02413398). Patients were randomized to either FARXIGA 10 mg or placebo, administered orally once daily. At Week 24, FARXIGA provided statistically significant reductions in HbA1c compared with placebo (Table 13).

Table 13: Results at Week 24 of Placebo-Controlled Study for FARXIGA in Patients with Type 2 Diabetes Mellitus and Renal Impairment (eGFR 45 to less than 60 mL/min/1.73 m²)

	FARXIGA 10 mg	Placebo
Number of patients:	N=160	N=161
HbA1c (%)		
Baseline (mean)	8.3	8.0
Change from baseline (adjusted mean*)	-0.4	-0.1
Difference from placebo (adjusted mean*) (95% CI)	-0.3 [†] (-0.5, - 0.1)	

* Least squares mean adjusted for baseline value; at Week 24, HbA1c was missing for 5.6% and 6.8% of individuals treated with FARXIGA and placebo, respectively. Retrieved dropouts, i.e. observed HbA1c at Week 24 from subjects who discontinued treatment, were used to impute missing values in HbA1c.

† p-value =0.008 versus placebo.

14.2 Cardiovascular Outcomes in Patients with Type 2 Diabetes Mellitus

Dapagliflozin Effect on Cardiovascular Events (DECLARE, NCT01730534) was an international, multicenter, randomized, double-blind, placebo-controlled, clinical study conducted to determine the effect of FARXIGA relative to placebo on CV outcomes when added to current background therapy. All patients had type 2 diabetes mellitus and either established CVD or two or more additional CV risk factors (age ≥ 55 years in men or ≥ 60 years in women and one or more of dyslipidemia, hypertension, or current tobacco use). Concomitant antidiabetic and atherosclerotic therapies could be adjusted, at the discretion of investigators, to ensure participants were treated according to the standard care for these diseases.

Of 17160 randomized patients, 6974 (40.6%) had established CVD and 10186 (59.4%) did not have established CVD. A total of 8582 patients were randomized to FARXIGA 10 mg, 8578 to placebo, and patients were followed for a median of 4.2 years.

Approximately 80% of the trial population was White, 4% Black or African-American, and 13% Asian. The mean age was 64 years, and approximately 63% were male.

Mean duration of diabetes was 11.9 years and 22.4% of patients had diabetes for less than 5 years. Mean eGFR was 85.2 mL/min/1.73 m². At baseline, 23.5% of patients had microalbuminuria (UACR ≥ 30 to ≤ 300 mg/g) and 6.8% had macroalbuminuria (UACR > 300 mg/g). Mean HbA1c was 8.3% and mean BMI was 32.1 kg/m². At baseline, 10% of patients had a history of heart failure.

Most patients (98.1%) used one or more diabetic medications at baseline. 82.0% of the patients were being treated with metformin, 40.9% with insulin, 42.7% with a sulfonylurea, 16.8% with a DPP4 inhibitor, and 4.4% with a GLP-1 receptor agonist.

Approximately 81.3% of patients were treated with angiotensin converting enzyme inhibitors or angiotensin receptor blockers, 75.0% with statins, 61.1% with antiplatelet therapy, 55.5% with acetylsalicylic acid, 52.6% with beta-blockers, 34.9% with calcium channel blockers, 22.0% with thiazide diuretics, and 10.5% with loop diuretics.

A Cox proportional hazards model was used to test for non-inferiority against the pre-specified risk margin of 1.3 for the hazard ratio (HR) of the composite of CV death, myocardial infarction (MI), or

ischemic stroke [MACE] and to test for superiority on the dual primary endpoints: the composite of hospitalization for heart failure or CV death, and MACE, if non-inferiority was demonstrated.

The incidence rate of MACE was similar in both treatment arms: 2.3 MACE events per 100 patient-years on dapagliflozin vs. 2.46 MACE events per 100 patient-years on placebo. The estimated hazard ratio of MACE associated with dapagliflozin relative to placebo was 0.93 with a 95.38% confidence interval of (0.84,1.03). The upper bound of this confidence interval, 1.03, excluded a risk margin larger than 1.3.

FARXIGA was superior to placebo in reducing the incidence of the primary composite endpoint of hospitalization for heart failure or CV death (HR 0.83 [95% CI 0.73, 0.95]).

The treatment effect was due to a significant reduction in the risk of hospitalization for heart failure in subjects randomized to FARXIGA (HR 0.73 [95% CI 0.61, 0.88]), with no change in the risk of CV death (Table 14 and Figures 4 and 5).

Table 14: Treatment Effects for the Primary Endpoints* and Their Components* in the DECLARE Study

Efficacy Variable (time to first occurrence)	Patients with events n (%)		Hazard ratio (95% CI)
	FARXIGA 10 mg N=8582	Placebo N=8578	
Primary Endpoints			
Composite of Hospitalization for Heart Failure, CV Death[†]	417 (4.9)	496 (5.8)	0.83 (0.73, 0.95)
Composite Endpoint of CV Death, MI, Ischemic Stroke	756 (8.8)	803 (9.4)	0.93 (0.84, 1.03)
Components of the composite endpoints[‡]			
Hospitalization for Heart Failure	212 (2.5)	286 (3.3)	0.73 (0.61, 0.88)
CV Death	245 (2.9)	249 (2.9)	0.98 (0.82, 1.17)
Myocardial Infarction	393 (4.6)	441 (5.1)	0.89 (0.77, 1.01)
Ischemic Stroke	235 (2.7)	231 (2.7)	1.01 (0.84, 1.21)

N=Number of patients, CI=Confidence interval, CV=Cardiovascular, MI=Myocardial infarction.

* Full analysis set.

† p-value =0.005 versus placebo.

‡ total number of events presented for each component of the composite endpoints

Figure 4: Time to First Occurrence of Hospitalization for Heart Failure or CV Death in the DECLARE Study

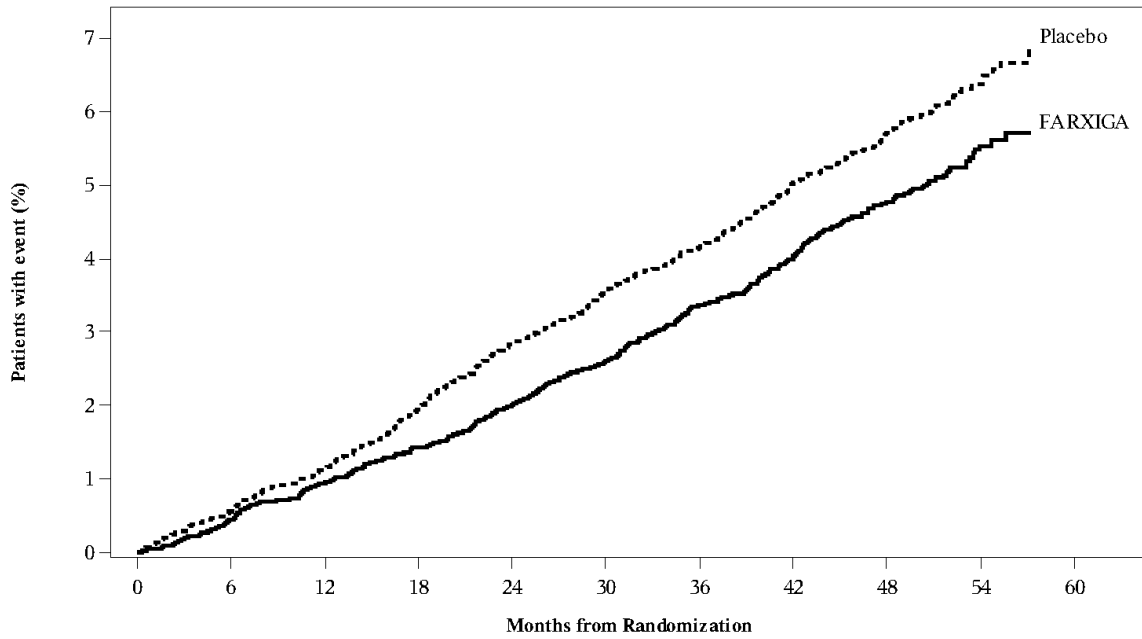

Patients at risk

FARXIGA:	8582	8517	8415	8322	8224	8110	7970	7497	5445	1626
Placebo:	8578	8485	8387	8259	8127	8003	7880	7367	5362	1573

Figure 5: Time to First Occurrence of Hospitalization for Heart Failure in the DECLARE Study

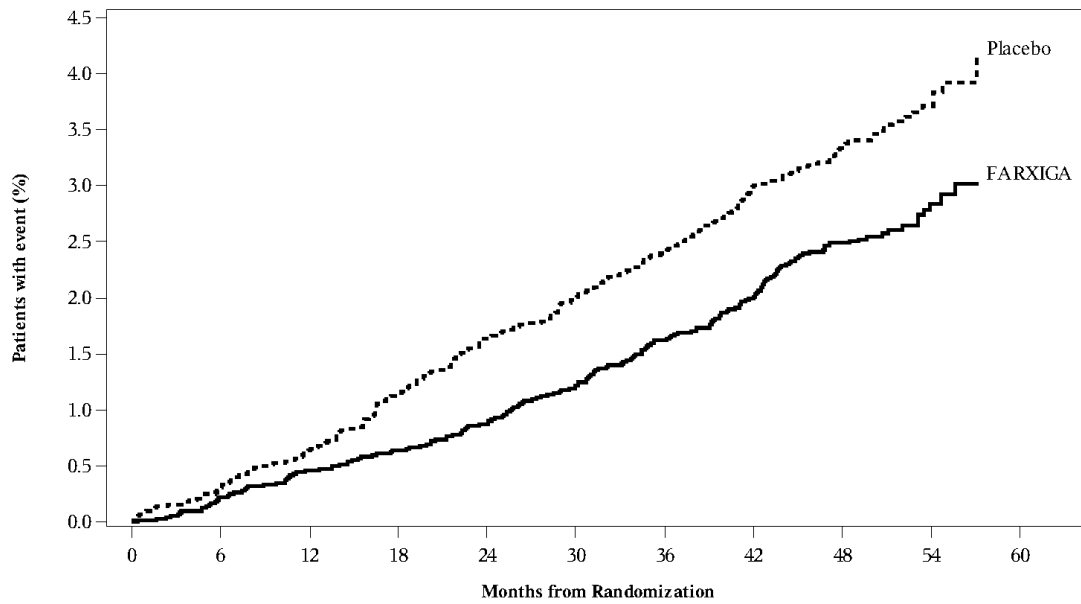

Patients at risk

FARXIGA:	8582	8509	8403	8315	8218	8101	7965	7489	5439	1626
Placebo:	8578	8482	8380	8256	8121	7998	7874	7360	5358	1572

14.3 Heart Failure with Reduced Ejection Fraction

Dapagliflozin And Prevention of Adverse outcomes in Heart Failure (DAPA-HF, NCT03036124) was an international, multicenter, randomized, double-blind, placebo-controlled study in patients with heart failure (New York Heart Association [NYHA] functional class II-IV) with reduced ejection fraction (left ventricular ejection fraction [LVEF] 40% or less) to determine whether FARXIGA reduces the risk of cardiovascular death and hospitalization for heart failure.

Of 4744 patients, 2373 were randomized to FARXIGA 10 mg and 2371 to placebo and were followed for a median of 18 months. The mean age of the study population was 66 years, 77% were male and 70% were White, 5% Black or African-American, and 24% Asian.

At baseline, 68% patients were classified as NYHA class II, 32% class III, and 1% class IV; median LVEF was 32%. History of type 2 diabetes mellitus was present in 42%, and an additional 3% had type 2 diabetes mellitus based on a HbA1c \geq 6.5% at both enrollment and randomization.

At baseline, 94% of patients were treated with ACEi, ARB or angiotensin receptor-neprilysin inhibitor (ARNI, including sacubitril/valsartan 11%), 96% with beta-blocker, 71% with mineralocorticoid receptor antagonist (MRA), 93% with diuretic, and 26% had an implantable device.

FARXIGA reduced the incidence of the primary composite endpoint of CV death, hospitalization for heart failure or urgent heart failure visit (HR 0.74 [95% CI 0.65, 0.85]; $p < 0.0001$). All three components of the primary composite endpoint individually contributed to the treatment effect. The FARXIGA and placebo event curves separated early and continued to diverge over the study period (Table 15, Figures 6A, 6B and 6C).

Table 15: Treatment Effect for the Primary Composite Endpoint*, its Components* and All-Cause Mortality in the DAPA-HF Study

Efficacy Variable (time to first occurrence)	Patients with events (event rate)		Hazard ratio (95% CI)	p-value [†]
	FARXIGA 10 mg N=2373	Placebo N=2371		
Composite of Hospitalization for Heart Failure, CV Death or Urgent Heart Failure Visit	386 (11.6)	502 (15.6)	0.74 (0.65, 0.85)	<0.0001
Composite of CV Death or Hospitalization for Heart Failure	382 (11.4)	495 (15.3)	0.75 (0.65, 0.85)	<0.0001
Components of the composite endpoints				
CV Death	227 (6.5)	273 (7.9)	0.82 (0.69, 0.98)	
Hospitalization for Heart Failure or Urgent Heart Failure Visit	237 (7.1)	326 (10.1)	0.70 (0.59, 0.83)	
Hospitalization for Heart Failure	231 (6.9)	318 (9.8)	0.70 (0.59, 0.83)	

Table 15: Treatment Effect for the Primary Composite Endpoint*, its Components* and All-Cause Mortality in the DAPA-HF Study

Efficacy Variable (time to first occurrence)	Patients with events (event rate)		Hazard ratio (95% CI)	p-value [†]
	FARXIGA 10 mg N=2373	Placebo N=2371		
Urgent Heart Failure Visit	10 (0.3)	23 (0.7)	0.43 (0.20, 0.90)	
All-Cause Mortality	276 (7.9)	329 (9.5)	0.83 (0.71, 0.97)	

N=Number of patients, CI=Confidence interval, CV=Cardiovascular.

* Full analysis set.

† Two-sided p-values.

NOTE: Time to first event was analyzed in a Cox proportional hazards model. The number of first events for the single components are the actual number of first events for each component and does not add up to the number of events in the composite endpoint. Event rates are presented as the number of subjects with event per 100 patient years of follow-up.

Figure 6: Kaplan-Meier Curves for the Primary Composite Endpoint (A), Cardiovascular Death (B), and Heart Failure Hospitalization (C)

Figure 6A: Time to the First Occurrence of the Composite of Cardiovascular Death, Hospitalization for Heart Failure or Urgent Heart Failure Visit

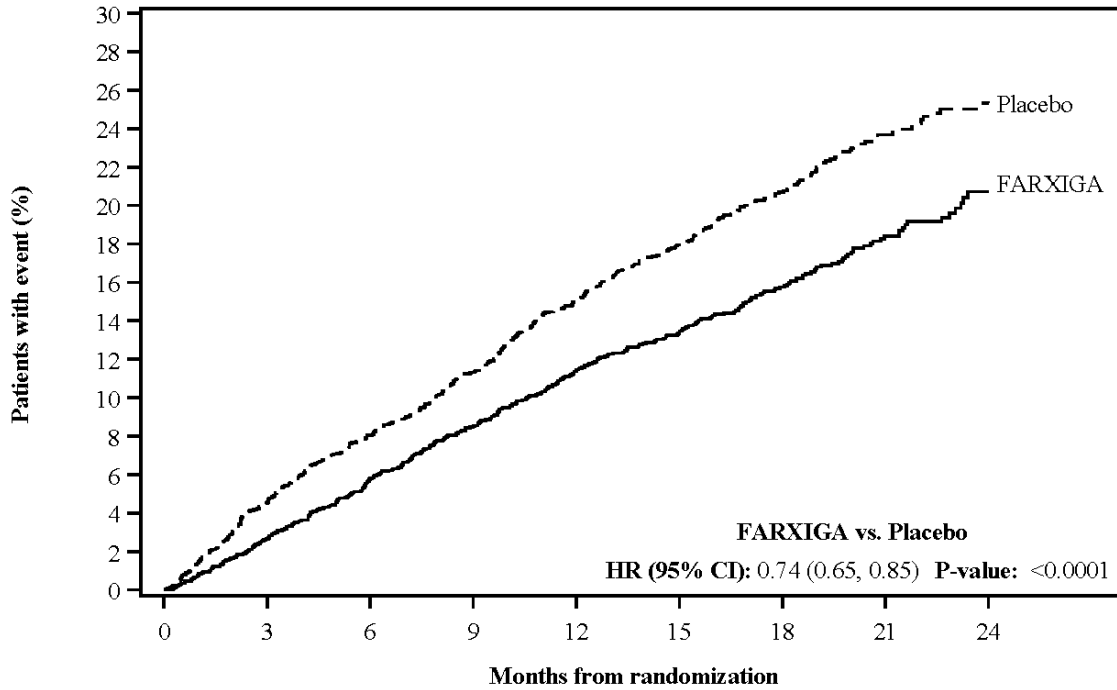

Patients at risk

FARXIGA:	2373	2305	2221	2147	2002	1560	1146	612	210
Placebo:	2371	2258	2163	2075	1917	1478	1096	593	210

NOTE: An urgent heart failure visit was defined as an urgent, unplanned, assessment by a physician, e.g. in an Emergency Department, and requiring treatment for worsening heart failure (other than just an increase in oral diuretics).

Patients at risk is the number of patients at risk at the beginning of the period.

HR=Hazard ratio, CI=Confidence interval.

Figure 6B: Time to the First Occurrence of Cardiovascular Death

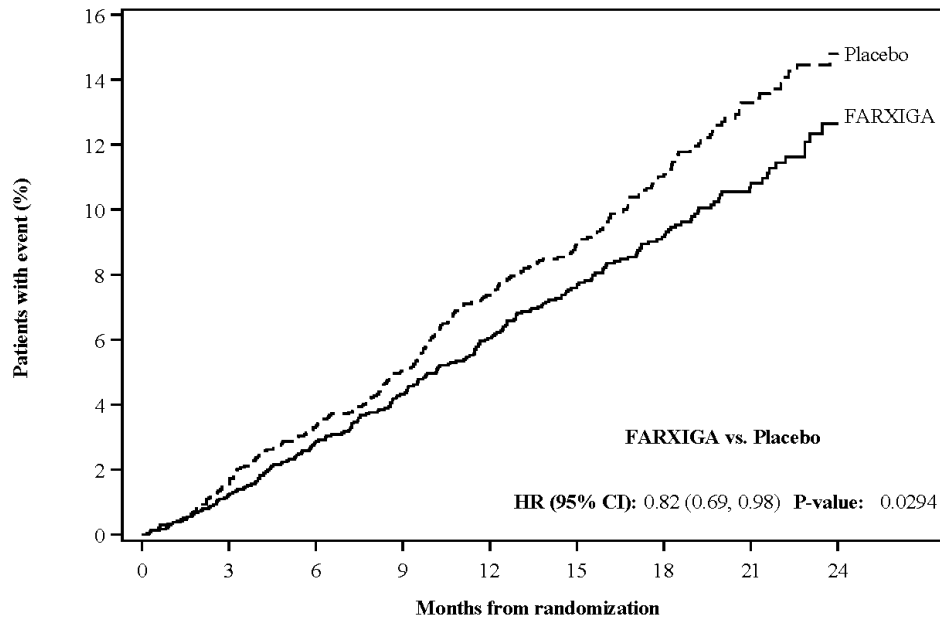

Patients at risk

FARXIGA:	2373	2339	2293	2248	2127	1664	1242	671	232
Placebo:	2371	2330	2279	2230	2091	1636	1219	664	234

Patients at risk is the number of patients at risk at the beginning of the period.
 HR=Hazard ratio, CI=Confidence interval.

Figure 6C: Time to the First Occurrence of Heart Failure Hospitalization

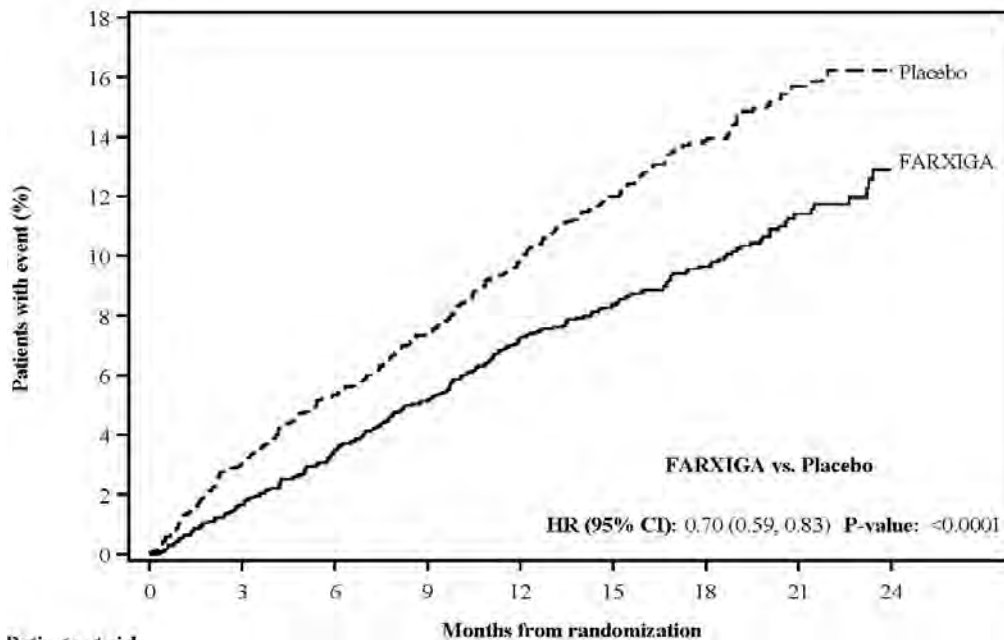

Patients at risk

FARXIGA:	2373	2306	2223	2153	2007	1563	1147	613	210
Placebo:	2371	2264	2168	2082	1924	1483	1101	596	212

Patients at risk is the number of patients at risk at the beginning of the period.
 HR=Hazard ratio, CI=Confidence interval.

FARXIGA reduced the total number of hospitalizations for heart failure (first and recurrent) events and CV death, with 567 and 742 total events in the FARXIGA-treated vs placebo group (Rate Ratio 0.75 [95% CI 0.65, 0.88]; p=0.0002).

The results of the primary composite endpoint were consistent across the subgroups examined, including heart failure patients with and without type 2 diabetes mellitus (Figure 7).

Figure 7: Treatment Effects for Primary Composite Endpoint (Cardiovascular Death and Heart Failure Events) Subgroup Analysis (DAPA-HF Study)

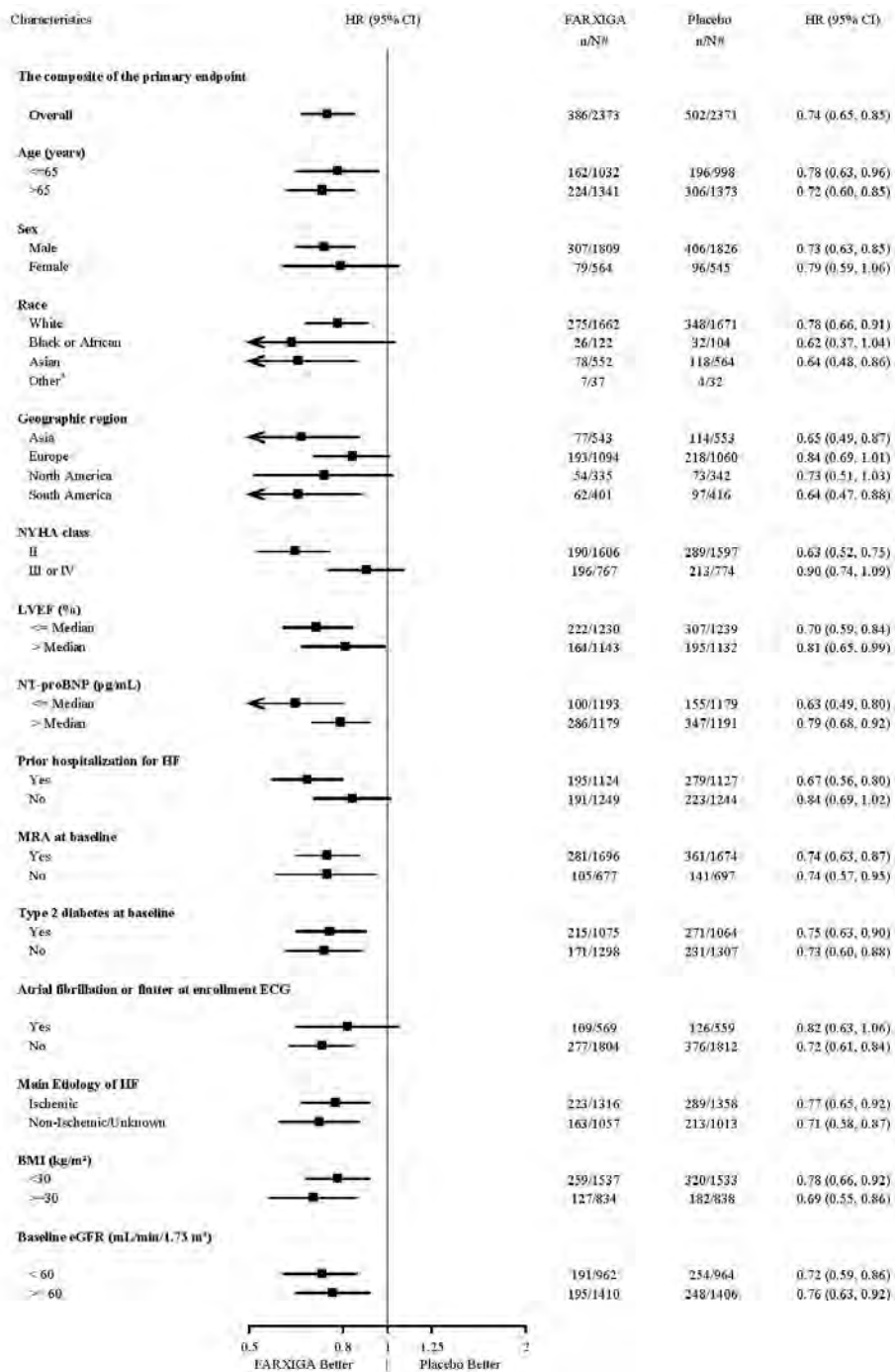

^a Hazard ratio estimates are not presented for subgroups with less than 15 events in total, both arms combined.

n/N# Number of subjects with event/number of subjects in the subgroup.

NT-proBNP = N-terminal pro b-type natriuretic peptide, HF = Heart failure, MRA = mineralocorticoid receptor antagonist, ECG = electrocardiogram, eGFR = estimated glomerular filtration rate.

Note: The figure above presents effects in various subgroups, all of which are baseline characteristics. The 95% confidence limits that are shown do not take into account the number of comparisons made and may not reflect the effect of a particular factor after adjustment for all other factors. Apparent homogeneity or heterogeneity among groups should not be over-interpreted.

16 HOW SUPPLIED/STORAGE AND HANDLING

How Supplied

FARXIGA (dapagliflozin) tablets have markings on both sides and are available in the strengths and packages listed in Table 16.

Table 16: FARXIGA Tablet Presentations

Tablet Strength	Film-Coated Tablet Color/Shape	Tablet Markings	Package Size	NDC Code
5 mg	yellow, biconvex, round	“5” engraved on one side and “1427” engraved on the other side	Bottles of 30	0310-6205-30
10 mg	yellow, biconvex, diamond-shaped	“10” engraved on one side and “1428” engraved on the other side	Bottles of 30	0310-6210-30

Storage and Handling

Store at 20°C to 25°C (68°F to 77°F); excursions permitted between 15°C and 30°C (59°F and 86°F) [see USP Controlled Room Temperature].

17 PATIENT COUNSELING INFORMATION

Advise the patient to read the FDA-approved patient labeling (Medication Guide).

Volume Depletion

Inform patients that symptomatic hypotension may occur with FARXIGA and advise them to contact their healthcare provider if they experience such symptoms [see [Warnings and Precautions \(5.1\)](#)]. Inform patients that dehydration may increase the risk for hypotension, and to have adequate fluid intake.

Ketoacidosis

Inform patients with diabetes mellitus that ketoacidosis is a serious life-threatening condition and that cases of ketoacidosis have been reported during use of FARXIGA with diabetes mellitus, sometimes associated with illness or surgery among other risk factors. Instruct patients to check ketones (when possible) if symptoms consistent with ketoacidosis occur even if blood glucose is not elevated. If symptoms of ketoacidosis (including nausea, vomiting, abdominal pain, tiredness and labored breathing) occur, instruct patients to discontinue FARXIGA and seek medical attention immediately [see [Warnings and Precautions \(5.2\)](#)].

Serious Urinary Tract Infections

Inform patients of the potential for urinary tract infections, which may be serious. Provide them with information on the symptoms of urinary tract infections. Advise them to seek medical advice promptly if such symptoms occur [see [Warnings and Precautions \(5.3\)](#)].

Necrotizing Fasciitis of the Perineum (Fournier's Gangrene)

Inform patients that necrotizing infections of the perineum (Fournier's Gangrene) have occurred with FARXIGA in patients with diabetes mellitus. Counsel patients to promptly seek medical attention if they develop pain or tenderness, redness, or swelling of the genitals or the area from the genitals back to the rectum, along with a fever above 100.4°F or malaise [see [Warnings and Precautions \(5.5\)](#)].

Genital Mycotic Infections in Females (e.g., Vulvovaginitis)

Inform female patients that vaginal yeast infections may occur and provide them with information on the signs and symptoms of vaginal yeast infections. Advise them of treatment options and when to seek medical advice [see [Warnings and Precautions \(5.6\)](#)].

Genital Mycotic Infections in Males (e.g., Balanitis)

Inform male patients that yeast infections of the penis (e.g., balanitis or balanoposthitis) may occur, especially in patients with prior history. Provide them with information on the signs and symptoms of balanitis and balanoposthitis (rash or redness of the glans or foreskin of the penis). Advise them of treatment options and when to seek medical advice [see [Warnings and Precautions \(5.6\)](#)].

Hypersensitivity Reactions

Inform patients that serious hypersensitivity reactions (e.g., urticaria, anaphylactic reactions, and angioedema) have been reported with FARXIGA. Advise patients to immediately report any signs or symptoms suggesting allergic reaction or angioedema, and to take no more of the drug until they have consulted prescribing physicians.

Pregnancy

Advise pregnant patients of the potential risk to a fetus with treatment with FARXIGA. Instruct patients to immediately inform their healthcare provider if pregnant or planning to become pregnant [see [Use in Specific Populations \(8.1\)](#)].

Lactation

Advise patients that use of FARXIGA is not recommended while breastfeeding [see [Use in Specific Populations \(8.2\)](#)].

Laboratory Tests

Due to its mechanism of action, patients taking FARXIGA will test positive for glucose in their urine.

Missed Dose

If a dose is missed, advise patients to take it as soon as it is remembered unless it is almost time for the next dose, in which case patients should skip the missed dose and take the medicine at the next regularly scheduled time. Advise patients not to take two doses of FARXIGA at the same time.

Distributed by:

AstraZeneca Pharmaceuticals LP

Wilmington, DE 19850

FARXIGA[®] is a registered trademark of the AstraZeneca group of companies.

MEDICATION GUIDE
FARXIGA® (FAR-SEE-GUH)
(dapagliflozin)
tablets, for oral use

What is the most important information I should know about FARXIGA?

FARXIGA can cause serious side effects, including:

- **Dehydration.** FARXIGA can cause some people to become dehydrated (the loss of body water and salt). Dehydration may cause you to feel dizzy, faint, lightheaded, or weak, especially when you stand up (orthostatic hypotension). There have been reports of sudden kidney injury in people with Type 2 diabetes who are taking FARXIGA. You may be at a higher risk of dehydration if you:
 - take medicines to lower your blood pressure, including water pills (diuretics)
 - are 65 years of age or older
 - are on a low salt diet
 - have kidney problems

Talk to your doctor about what you can do to prevent dehydration including how much fluid you should drink on a daily basis.

- **Vaginal yeast infection.** Women who take FARXIGA may get vaginal yeast infections. Symptoms of a vaginal yeast infection include:
 - vaginal odor
 - white or yellowish vaginal discharge (discharge may be lumpy or look like cottage cheese)
 - vaginal itching

- **Yeast infection of the penis (balanitis).** Men who take FARXIGA may get a yeast infection of the skin around the penis. Certain men who are not circumcised may have swelling of the penis that makes it difficult to pull back the skin around the tip of the penis. Other symptoms of yeast infection of the penis include:
 - redness, itching, or swelling of the penis
 - rash of the penis
 - foul smelling discharge from the penis
 - pain in the skin around the penis

Talk to your healthcare provider about what to do if you get symptoms of a yeast infection of the vagina or penis. Your healthcare provider may suggest you use an over-the-counter antifungal medicine. Talk to your healthcare provider right away if you use an over-the-counter antifungal medication and your symptoms do not go away.

What is FARXIGA?

FARXIGA is a prescription medicine used in adults with:

- **Type 2 diabetes to:**
 - improve blood sugar (glucose) control along with diet and exercise
 - reduce the risk of hospitalization for heart failure in people who also have known cardiovascular disease or multiple cardiovascular risk factors
- **Heart failure when the heart is weak and cannot pump enough blood to the rest of your body to:**
 - reduce the risk of cardiovascular death, hospitalization for heart failure

FARXIGA is not for people with type 1 diabetes.

FARXIGA is not for people with diabetic ketoacidosis (increased ketones in your blood or urine).

It is not known if FARXIGA is safe and effective in children younger than 18 years of age.

Who should not take FARXIGA?

Do not take FARXIGA if you:

- are allergic to dapagliflozin or any of the ingredients in FARXIGA. See the end of this Medication Guide for a list of ingredients in FARXIGA. Symptoms of a **serious** allergic reaction to FARXIGA may include:
 - skin rash
 - raised red patches on your skin (hives)
 - swelling of the face, lips, tongue, and throat that may cause difficulty in breathing or swallowing

If you have any of these symptoms, stop taking FARXIGA and contact your healthcare provider or go to the nearest hospital emergency room right away.

- have severe kidney problems and are taking FARXIGA to lower your blood sugar
- are on dialysis.

What should I tell my healthcare provider before taking FARXIGA?

Before you take FARXIGA, tell your healthcare provider if you:

- have type 1 diabetes or have had diabetic ketoacidosis.
- have kidney problems.
- have liver problems.
- have a history of urinary tract infections or problems urinating.
- are going to have surgery. Your doctor may stop your FARXIGA before you have surgery. Talk to your doctor if you are having surgery about when to stop taking FARXIGA and when to start it again.
- are eating less or there is a change in your diet.
- have or have had problems with your pancreas, including pancreatitis or surgery on your pancreas.
- drink alcohol very often or drink a lot of alcohol in the short term (“binge” drinking).
- are pregnant or plan to become pregnant. FARXIGA may harm your unborn baby. If you become pregnant while taking FARXIGA, your healthcare provider may switch you to a different medicine to control your blood sugar. Talk to your healthcare provider about the best way to control your blood sugar if you plan to become pregnant or while you are pregnant.
- are breastfeeding or plan to breastfeed. It is not known if FARXIGA passes into your breast milk. You should not breastfeed if you take FARXIGA.

Tell your healthcare provider about all the medicines you take, including prescription and over-the-counter medicines, vitamins, and herbal supplements.

How should I take FARXIGA?

- Take FARXIGA exactly as your healthcare provider tells you to take it.
- Do not change your dose of FARXIGA without talking to your healthcare provider.
- Take FARXIGA by mouth 1 time each day, with or without food.
- Stay on your prescribed diet and exercise program while taking FARXIGA.
- FARXIGA will cause your urine to test positive for glucose.
- Your healthcare provider may do certain blood tests before you start FARXIGA and during your treatment.
- If you miss a dose, take it as soon as you remember. If it is almost time for your next dose, skip the missed dose and take the medicine at the next regularly scheduled time. Do not take 2 doses of FARXIGA at the same time.
- If you take too much FARXIGA, call your healthcare provider or go to the nearest emergency room right away.
- If you have diabetes
 - When your body is under some types of stress, such as fever, trauma (such as a car accident), infection, or surgery, the amount of diabetes medicine you need may change. Tell your healthcare provider right away if you have any of these conditions and follow your healthcare provider’s instructions.
 - Your healthcare provider will check your diabetes with regular blood tests, including your blood sugar levels and your HbA1c.
 - Follow your healthcare provider’s instructions for treating low blood sugar (hypoglycemia). Talk to your healthcare provider if low blood sugar is a problem for you.

What are the possible side effects of FARXIGA? FARXIGA may cause serious side effects, including:

See “**What is the most important information I should know about FARXIGA?**”

- **Ketoacidosis in people with diabetes mellitus (increased ketones in your blood or urine).** Ketoacidosis has happened in people who have **type 1 diabetes or type 2 diabetes**, during treatment with FARXIGA. Ketoacidosis has also happened in people with diabetes who were sick or who had surgery during treatment with FARXIGA. Ketoacidosis is a serious condition, which may need to be treated in a hospital. Ketoacidosis may lead to death. **Ketoacidosis can happen with FARXIGA even if your blood sugar is less than 250 mg/dL. Stop taking FARXIGA and call your healthcare provider right away if you get any of the following symptoms:**
 - nausea
 - vomiting
 - stomach area (abdominal) pain
 - tiredness
 - trouble breathingIf you get any of these symptoms during treatment with FARXIGA, if possible, check for ketones in your urine, even if your blood sugar is less than 250 mg/dL.
- **Dehydration (loss of body water and salt).** Dehydration leading to symptoms of low blood pressure and changes in kidney function have happened in people who are taking FARXIGA. Call your healthcare provider right away if you:
 - reduce the amount of food or liquid you drink, for example if you cannot eat or
 - you start to lose liquids from your body, for example from vomiting, diarrhea, or being in the sun too long.
- **Serious urinary tract infections.** Serious urinary tract infections that may lead to hospitalization have happened in people who are taking FARXIGA. Tell your healthcare provider if you have any signs or symptoms of a urinary tract

infection such as a burning feeling when passing urine, a need to urinate often, the need to urinate right away, pain in the lower part of your stomach (pelvis), or blood in the urine. Sometimes people also may have a fever, back pain, nausea or vomiting.

- **Low blood sugar (hypoglycemia) in patients with diabetes mellitus.** If you take FARXIGA with another medicine that can cause low blood sugar, such as a sulfonylurea or insulin, your risk of getting low blood sugar is higher. The dose of your sulfonylurea medicine or insulin may need to be lowered while you take FARXIGA. Signs and symptoms of low blood sugar may include:
 - headache
 - shaking or feeling jittery
 - irritability
 - fast heartbeat
 - weakness
 - drowsiness
 - sweating
 - confusion
 - dizziness
 - hunger
- **A rare but serious bacterial infection that causes damage to the tissue under the skin (necrotizing fasciitis) in the area between and around the anus and genitals (perineum).** Necrotizing fasciitis of the perineum has happened in women and men with diabetes mellitus who take FARXIGA. Necrotizing fasciitis of the perineum may lead to hospitalization, may require multiple surgeries, and may lead to death. **Seek medical attention immediately if you have fever or you are feeling very weak, tired, or uncomfortable (malaise) and you develop any of the following symptoms in the area between and around the anus and genitals:**
 - pain or tenderness
 - swelling
 - redness of skin (erythema)

The most common side effects of FARXIGA include:

- vaginal yeast infections and yeast infections of the penis
- stuffy or runny nose and sore throat
- changes in urination, including urgent need to urinate more often, in larger amounts, or at night

These are not all the possible side effects of FARXIGA. For more information, ask your healthcare provider or pharmacist. Call your doctor for medical advice about side effects. You may report side effects to FDA at 1-800-FDA-1088.

How should I store FARXIGA?

Store FARXIGA at room temperature between 68°F to 77°F (20°C to 25°C).

General information about the safe and effective use of FARXIGA

Medicines are sometimes prescribed for purposes other than those listed in a Medication Guide. Do not use FARXIGA for a condition for which it is not prescribed. Do not give FARXIGA to other people, even if they have the same symptoms you have. It may harm them.

This Medication Guide summarizes the most important information about FARXIGA. If you would like more information, talk to your healthcare provider. You can ask your pharmacist or healthcare provider for information about FARXIGA that is written for healthcare professionals.

For more information about FARXIGA, go to www.farxiga.com or call 1-800-236-9933.

What are the ingredients in FARXIGA?

Active ingredient: dapagliflozin.

Inactive ingredients: microcrystalline cellulose, anhydrous lactose, croscopovidone, silicon dioxide, and magnesium stearate. The film coating contains: polyvinyl alcohol, titanium dioxide, polyethylene glycol, talc, and yellow iron oxide.

Distributed by: AstraZeneca Pharmaceuticals LP Wilmington, DE 19850

FARXIGA is a registered trademark of the AstraZeneca group of companies.

PRODUCT MONOGRAPH

 **FORXIGA[®]**

dapagliflozin tablets

(as dapagliflozin propanediol monohydrate)

5 mg and 10 mg

ATC Code: A10BK01

Sodium-glucose co-transporter 2 (SGLT2) inhibitors

AstraZeneca Canada Inc.
1004 Middlegate Road
Mississauga, Ontario
L4Y 1M4
www.astrazeneca.ca

Date of Preparation: June 29, 2020

Submission Control No: 234304

FORXIGA[®] is a registered trademark of AstraZeneca AB, used under license by AstraZeneca Canada Inc.

TABLE OF CONTENTS

PART I: HEALTH PROFESSIONAL INFORMATION	3
SUMMARY PRODUCT INFORMATION.....	3
INDICATIONS AND CLINICAL USE	3
CONTRAINDICATIONS.....	4
WARNINGS AND PRECAUTIONS	4
ADVERSE REACTIONS	9
DRUG INTERACTIONS	23
DOSAGE AND ADMINISTRATION	27
OVERDOSAGE.....	28
ACTION AND CLINICAL PHARMACOLOGY	29
STORAGE AND STABILITY	32
SPECIAL HANDLING INSTRUCTIONS.....	32
DOSAGE FORMS, COMPOSITION AND PACKAGING.....	33
PART II: SCIENTIFIC INFORMATION.....	34
PHARMACEUTICAL INFORMATION	34
CLINICAL TRIALS	34
DETAILED PHARMACOLOGY	60
TOXICOLOGY.....	61
PART III: CONSUMER INFORMATION.....	63

FORXIGA®

dapagliflozin tablets

(as dapagliflozin propanediol monohydrate)

PART I: HEALTH PROFESSIONAL INFORMATION

SUMMARY PRODUCT INFORMATION

Route of Administration	Dosage Form / Strength	Clinically Relevant Nonmedicinal Ingredients
oral	tablet / 5 mg, 10 mg	Lactose <i>For a complete listing see DOSAGE FORMS, COMPOSITION AND PACKAGING section.</i>

INDICATIONS AND CLINICAL USE

Type 2 Diabetes Mellitus (T2DM)

Monotherapy: FORXIGA (dapagliflozin) is indicated for use as an adjunct to diet and exercise to improve glycemic control in adult patients with T2DM for whom metformin is inappropriate due to contraindications or intolerance.

Add-on combination: FORXIGA is indicated in adult patients with T2DM to improve glycemic control in combination with

- metformin
- a sulfonylurea
- metformin and a sulfonylurea
- sitagliptin (alone or with metformin)
- insulin (alone or with metformin)

when metformin alone or the existing therapy listed above, along with diet and exercise, do not provide adequate glycemic control (see CLINICAL TRIALS).

Add-On Combination in Patients with Cardiovascular Risk Factors or Established Cardiovascular Disease: FORXIGA is indicated as an adjunct to diet, exercise, and standard of care therapy to reduce the risk of hospitalization for heart failure in adults with type 2 diabetes mellitus and CV risk factors or established CV disease (see CLINICAL TRIALS).

Geriatrics (≥65 years of age): No dosage adjustment is required in patients ≥65 years of age. FORXIGA should be used with caution in this population as a higher proportion of patients ≥65 years of age treated with FORXIGA had adverse reactions related to volume depletion and renal impairment or failure, compared to patients treated with placebo (see WARNINGS AND PRECAUTIONS, DOSAGE AND ADMINISTRATION and ACTION AND CLINICAL PHARMACOLOGY, Pharmacokinetics).

Pediatrics (<18 years of age): FORXIGA should not be used in pediatric patients. Safety and efficacy of FORXIGA have not been established in patients under 18 years of age.

Heart Failure (DAPA-HF)

FORXIGA is indicated in adults, as an adjunct to standard of care therapy, for the treatment of heart failure with reduced ejection fraction (HFrEF) to reduce the risk of cardiovascular (CV) death, hospitalization for heart failure and urgent heart failure visit (see CLINICAL TRIALS).

Pediatrics (<18 years of age): FORXIGA should not be used in pediatric patients. Safety and efficacy of FORXIGA have not been established in patients under 18 years of age.

CONTRAINDICATIONS

FORXIGA (dapagliflozin) is contraindicated in:

- Patients with a history of hypersensitivity reaction to the active substance or to any of the excipients. For a complete listing, see DOSAGE FORMS, COMPOSITION AND PACKAGING.
- Patients with an eGFR less than 30 mL/min/1.73m², end-stage renal disease (ESRD) or patients on dialysis (see WARNINGS AND PRECAUTIONS, Renal).

WARNINGS AND PRECAUTIONS

Serious Warnings and Precautions

Diabetic Ketoacidosis in Patients with Diabetes

- Clinical trial and post-market cases of diabetic ketoacidosis (DKA), a serious life-

threatening condition requiring urgent hospitalization, have been reported in patients with T2DM treated with FORXIGA (dapagliflozin) and other sodium-glucose co-transporter 2 (SGLT2) inhibitors. A number of these cases have been atypical with blood glucose values below 13.9 mmol/L (250 mg/dL) (see ADVERSE REACTIONS). Some cases of DKA have been fatal.

- Patients should be assessed for DKA immediately if non-specific symptoms such as difficulty breathing, nausea, vomiting, abdominal pain, confusion, anorexia, excessive thirst and unusual fatigue or sleepiness occur, regardless of blood glucose level. If DKA is suspected or diagnosed, FORXIGA should be **discontinued immediately**.
- FORXIGA should not be used for the treatment of DKA or in patients with a history of DKA.
- FORXIGA is not indicated, and should not be used, in patients with type 1 diabetes.

Cardiovascular

Use in patients at risk for volume depletion, hypotension and/or electrolyte imbalances:

Due to its mechanism of action, dapagliflozin causes osmotic diuresis that may be associated with decreases in blood pressure, which may be more pronounced in patients with high blood glucose concentrations.

Dapagliflozin is not recommended for use in patients who are volume depleted.

Caution should be exercised in patients for whom a dapagliflozin induced drop in blood pressure could pose a risk, such as elderly patients, patients with low systolic blood pressure or moderate renal impairment, or in case of intercurrent conditions that may lead to volume depletion (such as gastrointestinal illness).

Careful monitoring of volume status is recommended. Temporary interruption of FORXIGA may be considered for patients who develop volume depletion until the depletion is corrected (see WARNINGS AND PRECAUTIONS, Monitoring and Laboratory Tests, and ADVERSE REACTIONS).

Endocrine and Metabolism

Diabetic ketoacidosis in patients with diabetes: Clinical trial and post-market cases of DKA, a serious life-threatening condition requiring urgent hospitalization, have been reported in patients with T2DM treated with FORXIGA and other SGLT2 inhibitors. In a number of reported cases, the presentation of the condition was atypical with only moderately increased blood glucose values below 13.9 mmol/L (250 mg/dL) (see ADVERSE REACTIONS). Some cases of DKA have been fatal.

FORXIGA is not indicated, and should not be used, in patients with type 1 diabetes. The diagnosis of T2DM should therefore be confirmed before initiating FORXIGA as a treatment to improve glycemic control.

DKA must be considered in the event of non-specific symptoms such as difficulty breathing, nausea, vomiting, abdominal pain, confusion, anorexia, excessive thirst, and unusual fatigue

or sleepiness. **If DKA is suspected, regardless of blood glucose level, patients should discontinue FORXIGA treatment and be assessed for DKA immediately.**

Interruption of treatment with FORXIGA should be considered in T2DM patients who are hospitalized for major surgical procedures, serious infections or acute serious medical illness.

Conditions that can precipitate DKA while taking FORXIGA include a very low carbohydrate diet (as the combination may further increase ketone body production), dehydration, high alcohol consumption and a low beta-cell function reserve. These patients should be monitored closely. Caution should also be taken when reducing the insulin dose in patients requiring insulin (see DOSAGE AND ADMINISTRATION).

Use with medications known to cause hypoglycemia: Insulin and insulin secretagogues, such as sulfonylureas, cause hypoglycemia. Therefore, a lower dose of insulin or the insulin secretagogue may be required to reduce the risk of hypoglycemia when used in combination with FORXIGA (see ADVERSE REACTIONS and DOSAGE AND ADMINISTRATION).

Increases in Low-Density Lipoprotein (LDL-C): Dose-related increases in LDL-C are seen with FORXIGA treatment (see ADVERSE REACTIONS). LDL-C levels should be monitored.

Genitourinary

Genital mycotic infections: Patients, particularly those with a history of genital mycotic infections, should be advised that FORXIGA increases the risk of genital mycotic infections (see ADVERSE REACTIONS).

Urinary tract infections (including urosepsis and pyelonephritis): Treatment with FORXIGA increases the risk for urinary tract infections (see ADVERSE REACTIONS). There have been post-marketing reports of serious urinary tract infections, including urosepsis and pyelonephritis, requiring hospitalization in patients treated with FORXIGA. Evaluate patients for signs and symptoms of urinary tract infections and treat promptly, if indicated.

Necrotizing fasciitis of the perineum (Fournier's gangrene): Post-marketing cases of necrotizing fasciitis of perineum (Fournier's gangrene), a rare but serious and potentially life-threatening necrotizing infection requiring urgent surgical intervention, have been reported in female and male patients with diabetes mellitus receiving SGLT2 inhibitors, including FORXIGA. Serious outcomes have included hospitalization, multiple surgeries, and death.

Patients treated with FORXIGA who present with pain or tenderness, erythema, or swelling in the genital or perineal area, with or without fever or malaise, should be evaluated for necrotizing fasciitis. If suspected, FORXIGA should be discontinued and prompt treatment should be instituted (including broad-spectrum antibiotics and surgical debridement if necessary).

Hematologic

Elevated hemoglobin and hematocrit: Mean hemoglobin and hematocrit increased in patients administered FORXIGA, as did the number of patients with abnormally elevated values for hemoglobin/hematocrit (see ADVERSE REACTIONS). FORXIGA should be used with caution in patients with an elevated hematocrit.

Hepatic/Biliary/Pancreatic

Elevations in hepatic transaminases have been reported in dapagliflozin treated patients in clinical trials; however, a causal relationship with dapagliflozin has not been established. FORXIGA exposure is increased in patients with severe hepatic impairment (see DOSAGE AND ADMINISTRATION and ACTION AND CLINICAL PHARMACOLOGY). Use of FORXIGA is not recommended in patients with severe hepatic impairment.

Renal

Initiation of FORXIGA may transiently increase serum creatinine and decreases eGFR in a dose dependent fashion. In clinical trials, renal function abnormalities have occurred after initiating FORXIGA.

Type 2 Diabetes Mellitus

Post-marketing cases of acute kidney injury, including acute renal failure, shortly after the initiation of FORXIGA treatment have been reported in T2DM patients (see ADVERSE REACTIONS). Patients with hypovolemia may be more susceptible to these changes (see ADVERSE REACTIONS).

Renal function should be assessed prior to initiation of FORXIGA and regularly thereafter, with more frequent monitoring in patients whose eGFR decreases to $<60 \text{ mL/min/1.73m}^2$.

FORXIGA is not recommended for use in patients with T2DM, being treated for glycemic control, with an eGFR persistently $<45 \text{ mL/min/1.73m}^2$, severe renal impairment, ESRD, or patients on dialysis as the glycemic efficacy of dapagliflozin is dependent on renal function (see ADVERSE REACTIONS, DOSAGE AND ADMINISTRATION, and CLINICAL TRIALS). In such patients, FORXIGA did not improve glycemic control and adverse reactions were more frequent (see ADVERSE REACTIONS). FORXIGA is contraindicated in patients with an eGFR less than $30 \text{ mL/min/1.73m}^2$, ESRD or patients on dialysis (see CONTRAINDICATIONS).

Before initiating FORXIGA, consider factors that may predispose patients to acute kidney injury including hypovolemia, chronic renal insufficiency, congestive heart failure and concomitant medications (diuretics, ACE inhibitors, ARBs, NSAIDs). Consider temporarily discontinuing FORXIGA in any setting of reduced oral intake (such as acute illness or fasting) or fluid losses (such as gastrointestinal illness or excessive heat exposure); monitor patients for signs and symptoms of acute kidney injury. If acute kidney injury occurs, discontinue FORXIGA promptly and institute treatment.

Heart Failure (DAPA-HF)

There is limited experience with FORXIGA in patients with severe renal impairment (eGFR <30 mL/min/1.73m²) or ESRD. FORXIGA is contraindicated in patients with an eGFR less than 30 mL/min/1.73m², ESRD or patients on dialysis (see CONTRAINDICATIONS).

Special Populations

Pregnant Women: FORXIGA must not be used in pregnancy. In the time period corresponding to second and third trimesters of pregnancy with respect to human renal maturation, maternal exposure to dapagliflozin in rat studies was associated with increased incidence and/or severity of renal pelvic and tubular dilatations in progeny (see TOXICOLOGY).

There are no adequate and well-controlled studies of FORXIGA in pregnant women. When pregnancy is detected, FORXIGA should be discontinued.

Nursing Women: FORXIGA must not be used by a nursing woman. Studies in rats have shown excretion of FORXIGA in milk. Direct and indirect exposure of FORXIGA to weanling juvenile rats and during late pregnancy are each associated with increased incidence and/or severity of renal pelvic and tubular dilatations in progeny, although the long-term functional consequences of these effects are unknown. These periods of exposure coincide with a critical window of renal maturation in rats. As functional maturation of the kidneys in humans continues in the first 2 years of life, FORXIGA-associated dilated renal pelvis and tubules noted in juvenile rats could constitute potential risk for human renal maturation during the first 2 years of life. Additionally, the negative effects on body weight gain associated with lactational exposure in weanling juvenile rats suggest that FORXIGA must be avoided during the first 2 years of life (see TOXICOLOGY).

It is not known whether FORXIGA and/or its metabolite are excreted in human milk.

Pediatrics (<18 years of age): Safety and effectiveness of FORXIGA in pediatric patients have not been established, therefore FORXIGA should not be used in this population.

Geriatrics (≥65 years of age): A total of 2403 (26%) of the 9339 treated patients were 65 years and over and 327 (3.5%) patients were 75 years and over in the pool of 21 double-blind, controlled clinical safety and efficacy studies of FORXIGA in improving glycemic control. After controlling for renal function (eGFR), there was no conclusive evidence suggesting that age is an independent factor affecting efficacy. No dosage adjustment is required in patients ≥65 years of age. In patients ≥65 years of age, a higher proportion of patients treated with FORXIGA had adverse events related to volume depletion and renal impairment or failure compared with placebo. The most commonly reported adverse events related to renal impairment or failure in patients ≥65 years of age in any treatment group were creatinine renal clearance decreased, renal impairment, and increased blood creatinine.

Older patients are more likely to have impaired renal function (see WARNINGS AND PRECAUTIONS, Monitoring and Laboratory Tests, Renal Function, and ADVERSE REACTIONS).

Monitoring and Laboratory Tests

Blood glucose and HbA1c: Response to FORXIGA treatment in T2DM patients should be monitored by periodic measurements of blood glucose and HbA1c levels.

Due to its mechanism of action, patients taking FORXIGA will test positive for glucose in their urine (see DRUG INTERACTIONS, Drug-Laboratory Interactions).

Renal function: Renal function should be assessed prior to initiation of FORXIGA and regularly thereafter. FORXIGA is not recommended for use in patients with T2DM, being treated for glycemic control, with an eGFR persistently <45 mL/min/1.73m², severe renal impairment, ESRD, or patients on dialysis as the glycemic efficacy of dapagliflozin is dependent on renal function (see ADVERSE REACTIONS, DOSAGE AND ADMINISTRATION, and CLINICAL TRIALS). FORXIGA is contraindicated in patients with an eGFR less than 30 mL/min/1.73m², ESRD or patients on dialysis (see CONTRAINDICATIONS).

Monitoring of renal function is recommended prior to and following initiation of any concomitant drug which might have an impact on renal function.

Reduced intravascular volume: FORXIGA is not recommended for use in patients who are volume depleted (see DOSAGE AND ADMINISTRATION). Before initiating FORXIGA, assess volume status, particularly in patients at risk (see WARNINGS AND PRECAUTIONS, Cardiovascular, and DOSAGE AND ADMINISTRATION) as well as in case of intercurrent conditions that may lead to fluid loss (such as a gastrointestinal illness) for patients already taking FORXIGA. In these patients, careful monitoring of volume status (e.g., physical examination, blood pressure measurements, laboratory tests, including hematocrit, serum electrolytes and renal function tests) is recommended. If volume depletion develops, temporary interruption of treatment with FORXIGA may be considered until fluid loss is corrected.

LDL-cholesterol: LDL-C levels should be measured at baseline and at regular intervals during treatment with FORXIGA due to dose-dependent increases in LDL-C seen with therapy.

ADVERSE REACTIONS

Adverse Drug Reaction Overview

Clinical trials of FORXIGA to improve glycemic control

The overall incidence of adverse events in a 12-study, short-term, placebo-controlled pool (short-term treatment) in T2DM patients treated with FORXIGA 5 mg and 10 mg for glycemic control was 61.9% and 61.5%, respectively compared to 56.9% for the placebo group.

The most commonly reported adverse events during treatment with FORXIGA 5 mg or 10 mg ($\geq 5\%$) were female genital mycotic infections, nasopharyngitis and urinary tract infections. Discontinuation of therapy due to adverse events in patients who received FORXIGA 5 mg and 10 mg was 2.8% and 3.2%, respectively, compared to 2.5% for the placebo group. The most commonly reported events leading to discontinuation and reported in at least three (3) FORXIGA 10 mg-treated patients were renal impairment (0.8%), decrease in creatinine clearance (0.6%), increased blood creatinine (0.3%), urinary tract infections (0.2%), and vulvovaginal mycotic infection (0.1%).

A total of 10 serious adverse drug events, assessed as related by the investigator, were reported in 9 patients in the short-term, placebo-controlled pool: 2 reports from patients taking FORXIGA 5 mg daily (change of bowel habit, hypoglycemia), 2 reports from patients taking FORXIGA 10 mg daily (constipation, rotator cuff syndrome) and 6 reports from patients in the placebo group (thrombocytopenia, acute myocardial infarction, cystitis, pyelonephritis, overdose and loss of consciousness).

Cardiovascular outcomes trial (DECLARE-TIMI 58)

The overall incidence of serious adverse events (SAEs) in DECLARE-TIMI 58 was 34.1% in the dapagliflozin group and 36.2% in the placebo group. The most commonly reported SAEs were angina unstable (2.8% dapagliflozin vs 2.8% placebo), acute myocardial infarction (2.7% vs 2.3%), and pneumonia (1.9% vs 2.1%). Discontinuations of study drug due to an AE were reported in 8.1% and 6.9% of patients in the FORXIGA and placebo groups, respectively. The most common events leading to discontinuation were urinary tract infection (0.5% vs 0.3%), balanoposthitis (0.3% vs $<0.1\%$), and pollakiuria (0.2% vs 0.2%).

Heart Failure (DAPA-HF)

In the dapagliflozin CV outcome study in patients with HFrEF (DAPA-HF), 2368 patients were treated with dapagliflozin 10 mg and 2368 patients with placebo for a median exposure time of 18 months.

The numbers of patients with serious adverse events were fewer in the dapagliflozin treatment group compared with the placebo group: 35.7% vs 40.2%, respectively. The three most commonly reported serious adverse events in both treatment groups were cardiac failure, pneumonia and cardiac failure congestive. Discontinuations due to adverse events were low and balanced between patients on dapagliflozin treatment versus placebo (4.7% vs. 4.9%, respectively). The most common adverse events leading to permanent discontinuation of FORXIGA 10 mg were cardiac failure, dizziness and hypotension for the dapagliflozin treatment group and cardiac failure, cardiac failure congestive and renal impairment for the placebo group.

Clinical Trial Adverse Drug Reactions

Because clinical trials are conducted under very specific conditions the adverse reaction rates observed in the clinical trials may not reflect the rates observed in practice and should not be compared to the rates in the clinical trials of another drug. Adverse drug reaction information from clinical trials is useful for identifying drug-related adverse events and for approximating rates.

FORXIGA has been evaluated in clinical trials in patients with T2DM and in patients with HFrEF. The overall safety profile of FORXIGA was consistent across the studied dapagliflozin indications. DKA was observed only in patients with T2DM.

Clinical Trials in Patients with T2DM Treated for Glycemic Control

Three major pools of patients with T2DM, who were being treated for glycemic control, were used to evaluate adverse reactions with FORXIGA 5 mg and 10 mg versus control, including two placebo-controlled study pools and a larger pool of active- and placebo-controlled studies. In addition, adverse reactions were evaluated with FORXIGA 10 mg versus placebo in a dedicated CV outcomes trial (DECLARE-TIMI 58).

Placebo-Controlled Studies for FORXIGA 5 mg and 10 mg: The first pool of patients was derived from 12 placebo-controlled studies ranging from 12 to 24 weeks. In 4 studies FORXIGA was used as monotherapy, and in 8 studies FORXIGA was used as add-on to background antidiabetic therapy or as combination therapy with metformin. These data reflect exposure of 2338 patients to FORXIGA with a mean exposure duration of 21 weeks. Patients received placebo (N=1393), FORXIGA 5 mg (N=1145), or FORXIGA 10 mg (N=1193) once daily.

Pool of 13 Placebo-Controlled Studies for FORXIGA 10 mg: The safety and tolerability of FORXIGA 10 mg was also evaluated in a larger placebo-controlled study pool. This pool combined 13 placebo-controlled studies, including 3 monotherapy studies, 9 add-on to background antidiabetic therapy studies, and an initial combination with metformin study. Across these 13 studies, 2360 patients were treated once daily with FORXIGA 10 mg for a mean duration of exposure of 22 weeks.

Active- and Placebo-Controlled Studies: The third pool of patients was derived from 21 active- and placebo-controlled studies used to evaluate and present data for malignancies and liver tests. In this pool, 5936 patients were treated with FORXIGA and 3403 were treated with control (either as monotherapy or in combination with other antidiabetic therapies).

Cardiovascular Outcomes Trial (DECLARE-TIMI 58): The safety and tolerability of FORXIGA 10 mg, as add-on to standard of care therapy, was also evaluated in a dedicated CV outcomes study in adult patients with T2DM and CV risk factors or established cardiovascular disease. In this study, 8574 patients received FORXIGA 10 mg and 8569 received placebo for a mean exposure time of 42 months.

The adverse events in the 12-study placebo-controlled pooled analysis reported in $\geq 2\%$ of T2DM patients treated with FORXIGA 5 mg or 10 mg for glycemic control, and occurring more frequently than in patients treated with placebo, are shown in Table 1.

Table 1 Adverse Events Reported in $\geq 2\%$ of T2DM Patients Treated for Glycemic Control with FORXIGA 5 mg or 10 mg and More Frequently than in Patients Treated with Placebo

System organ class Preferred term	% of Patients (Pool of 12 Placebo-controlled Studies)		
	FORXIGA 5 mg N=1145	FORXIGA 10 mg N=1193	Placebo N=1393
Gastrointestinal disorders			
Constipation	2.2	1.9	1.5
Nausea	2.8	2.5	2.4
Infections and infestations			
Influenza	2.7	2.3	2.3
Nasopharyngitis	6.6	6.3	6.2
Female genital mycotic infection†	8.4	6.9	1.5
Male genital mycotic infection‡	2.8	2.7	0.3
Urinary Tract Infection§	5.7	4.3	3.7
Metabolism and nutrition disorders			
Dyslipidemia	2.1	2.5	1.5
Musculoskeletal and Connective Tissue Disorders			
Back pain	3.1	4.2	3.2
Pain in extremity	2.0	1.7	1.4
Renal and Urinary disorders			
Increased urination¶	2.9	3.8	1.7
Discomfort with urination	1.6	2.1	0.7

† Genital mycotic infections include the following preferred terms, listed in order of frequency reported for females: vulvovaginal mycotic infection, vaginal infection, vulvovaginal candidiasis, vulvovaginitis, genital infection, genital candidiasis, fungal genital infection, vulvitis, genitourinary tract infection, vulval abscess, and vaginitis bacterial (N for females: FORXIGA 5 mg=581, FORXIGA 10 mg=598, Placebo=677).

‡ Genital mycotic infections include the following preferred terms, listed in order of frequency reported for males: balanitis, fungal genital infection, balanitis candida, genital candidiasis, genital infection male, penile infection, balanoposthitis, balanoposthitis infective, genital infection and posthitis (N for males: FORXIGA 5 mg=564, FORXIGA 10 mg=595, Placebo=716).

- § Urinary tract infections include the following preferred terms, listed in order of frequency reported: urinary tract infection, cystitis, Escherichia urinary tract infection, genitourinary tract infection, pyelonephritis, trigonitis, urethritis, kidney infection, and prostatitis.
- ¶ Increased urination includes the following preferred terms, listed in order of frequency reported: pollakiuria, polyuria, and urine output increased.

Additional adverse events in $\geq 5\%$ of T2DM patients, treated with FORXIGA for glycemic control, seen more frequently than in patients in the placebo/comparator group, and reported in at least three or more patients treated with FORXIGA 5 mg or 10 mg are described below by treatment regimen.

Table 2 Adverse Events Reported in $\geq 5\%$ of T2DM Patients Treated with FORXIGA 5 mg or 10 mg for Glycemic Control and Observed More Frequently than in Patients Treated with Placebo/Comparator and Reported in at least Three or More Patients Treated with FORXIGA 5 mg or 10 mg

Treatment Regimen Adverse Event (Preferred term)	n (%) of Patients		
	FORXIGA 5 mg	FORXIGA 10 mg	Placebo/ Comparator
Monotherapy	N=132	N=146	N=75
Diarrhea	8 (6.1)	4 (2.7)	1 (1.3)
Upper respiratory infection	2 (1.5)	9 (6.2)	1 (1.3)
Arthralgia	8 (6.1)	7 (4.8)	1 (1.3)
Headache	12 (9.1)	13 (8.9)	5 (6.7)
Add-on to Metformin	N=137	N=135	N=137
Diarrhea	5 (3.6)	10 (7.4)	7 (5.1)
Headache	10 (7.3)	11 (8.1)	6 (4.4)
Add-on to Metformin versus Glipizide	FORXIGA (any dose)		
	N=406		N=408
Headache	21 (5.2)		17 (4.2)

Less Common Clinical Trial Adverse Drug Reactions in Patients with T2DM Being Treated for Glycemic Control (<2 %)¹

Gastrointestinal disorder: dry mouth.

Investigations: weight decreased.

¹ Based on medical assessment (including biological plausibility/mechanism of action) of adverse events reported in <2% of subjects in the 12-study placebo-controlled pool.

Metabolism and nutrition disorders: dehydration, hypotension, thirst.

Renal and urinary disorders: glomerular filtration rate decreased, nocturia.

Reproductive and breast disorders: pruritus genital, vulvovaginal pruritus.

Description of Selected Adverse Reactions in T2DM Patients Being Treated for Glycemic Control

Volume depletion and hypotension: Events related to volume depletion (including reports of dehydration, hypovolemia, orthostatic hypotension, or hypotension) were reported in 0.6%, 0.8% and 0.4% of patients who received FORXIGA 5 mg, FORXIGA 10 mg and placebo, respectively, in the 12-study, short-term, placebo-controlled pool. Serious events occurred in $\leq 0.2\%$ of patients across the 21 active- and placebo-controlled studies and were balanced between FORXIGA 10 mg and comparator.

Postural blood pressure measurement revealed orthostatic hypotension in 13.1% of patients treated with FORXIGA 10 mg vs. 11.3% of patients treated with placebo over the 24-week treatment period. In addition, in two studies with patients with T2DM and hypertension, postural blood pressure measurement revealed orthostatic hypotension in 3.2% of FORXIGA 10 mg-treated patients vs. 1.7% of placebo-treated patients across the two studies over the 12-week treatment period.

Genital mycotic infections: Events of genital mycotic infections were reported in 5.7% (65/1145), 4.8% (57/1193) and 0.9% (12/1393) of patients who received FORXIGA 5 mg, FORXIGA 10 mg and placebo, respectively, in the 12-study, short-term, placebo-controlled pool. Infections were more frequently reported in females (8.4% [49/581], 6.9% [41/598] FORXIGA 5 mg and 10 mg, respectively, vs. 1.5% [10/677] placebo) than in males (2.8% [16/564], 2.7% [16/595] FORXIGA 5 mg and 10 mg, respectively vs. 0.3% [2/716] placebo). The most frequently reported genital infections were vulvovaginal mycotic infections in females, and balanitis in males (see Table 1).

Patients who had a previous history of recurrent genital mycotic infections, were more likely to have an event of genital infection during the study than those without a history of infection (23.1%, [3/13] 25.0% [3/12] and 10.0% [1/10] versus 5.9% [60/1013], 5.0% [53/1053] and 0.8% [10/1247] on FORXIGA 5 mg, FORXIGA 10 mg and placebo, respectively).

Urinary tract infections: Events of urinary tract infections (UTI) were reported in 5.7% (65/1145), 4.3% (51/1193), and 3.7% (52/1393) of patients who received FORXIGA 5 mg, FORXIGA 10 mg and placebo, respectively, in the 12-study, short term, placebo-controlled pool. Infections were more frequently reported in females (9.6% [56/581] and 7.7% [46/598] FORXIGA 5 mg and 10 mg, respectively, vs. 6.6% [45/677] placebo) than in males (1.6% [9/564] and 0.8% [5/595] FORXIGA 5 mg and 10 mg, respectively, vs. 1.0% [7/716] placebo).

In 9 of the 13 studies in the FORXIGA 10 mg placebo-controlled pool for which long-term treatment data were available (mean duration of treatment 439.5 days for FORXIGA 10 mg

and 419.0 days for placebo), of the 174 patients treated with FORXIGA 10 mg who experienced an infection, 135 (77.6%) had only one and 11 (6.3%) had 3 or more. Of the 121 patients treated with placebo who experienced an infection, 94 (77.7%) had only one and 12 (9.9%) had 3 or more.

In the 13-study, short-term, placebo-controlled pool, patients who had a previous history of recurrent urinary tract infection, were more likely to have an event of urinary tract infection (6.0% [26/436] of patients with history of infection treated with FORXIGA 10 mg and 5.9% [24/407] of patients with history of infection on placebo) during the study than those without a history of infection (4.4% [84/1924] on FORXIGA 10 mg and 3.0% [57/1888] on placebo).

Hypoglycemia: The frequency of hypoglycemia depended on the type of background therapy used in each study (see Table 3). Studies of FORXIGA as an add-on to sulfonylurea or as an add-on to insulin therapy had higher rates of hypoglycemia with FORXIGA treatment than with placebo treatment (see WARNINGS AND PRECAUTIONS).

Table 3 Incidence of Major* and Minor† Hypoglycemia in Placebo-Controlled Studies in T2DM Patients Being Treated for Glycemic Control

	FORXIGA 5 mg	FORXIGA 10 mg	Placebo
Monotherapy (24 weeks)	N=64	N=70	N=75
Major [n (%)]	0	0	0
Minor [n (%)]	0	0	0
Add-on to Metformin (24 weeks)	N=137	N=135	N=137
Major [n (%)]	0	0	0
Minor [n (%)]	2 (1.5)	1 (0.7)	0
Active Control Add-on to Metformin vs. Glipizide (52 weeks)	-	N=406	N=408
Major [n (%)]	-	0	3 (0.7)
Minor [n (%)]	-	7 (1.7)	147 (36.0)
Add-on to Glimepiride (24 weeks)	N=145	N=151	N=146
Major [n (%)]	0	0	0
Minor [n (%)]	8 (5.5)	9 (6.0)	3 (2.1)
Add-on to Metformin and Sulfonylurea (24 weeks)	-	N=109	N=109
Major [n (%)]	-	0	0
Minor [n (%)]	-	14 (12.8)	4 (3.7)
Add-on to Sitagliptin alone or with metformin (24 weeks)	-	N=225	N=226
Major [n (%)]	-	1 (0.4)	0

Table 3 Incidence of Major* and Minor† Hypoglycemia in Placebo-Controlled Studies in T2DM Patients Being Treated for Glycemic Control

	FORXIGA 5 mg	FORXIGA 10 mg	Placebo
Minor [n (%)]	-	4 (1.8)	3 (1.3)
Add-on to Insulin with or without other OADs (24 weeks)	N=212	N=196	N=197
Major [n (%)]	1 (0.5)	1 (0.5)	1 (0.5)
Minor [n (%)]	92 (43.4)	79 (40.3)	67 (34.0)
CV outcomes study (42 months mean exposure) §			
All Patients	-	N=8574	N=8569
Major [n (%)]	-	58 (0.7)	83 (1.0)
Minor [n (%)]	-	Not collected	Not collected
Patients treated with Insulin	-	N=4177	N=4606
Major [n (%)]	-	52 (1.2)	64 (1.4)
Patients treated with a Sulfonylurea	-	N=4118	N=4521
Major [n(%)]	-	14 (0.3)	23 (0.5)

* Major episodes of hypoglycemia were defined as symptomatic episodes requiring external (third party) assistance due to severe impairment in consciousness or behavior with a capillary or plasma glucose value <3 mmol/L and prompt recovery after glucose or glucagons administration.

† Minor episodes of hypoglycemia were defined as either a symptomatic episode with a capillary or plasma glucose measurement <3.5 mmol/L regardless of need for external assistance or an asymptomatic capillary or plasma glucose measurement <3.5 mmol/L which did not qualify as a major episode.

‡ OAD = oral antidiabetic therapy

§ Patients were on treatment at the time of the events.

Monotherapy and add-on to metformin: In studies with FORXIGA used as monotherapy, add-on to metformin, and initial combination with metformin for up to 102 weeks, there were no major episodes of hypoglycemia reported. In these studies, the frequency of minor episodes of hypoglycemia was similar (<5%) across the treatment groups, including placebo.

In an add-on to metformin study that compared FORXIGA to glipizide up to 104 weeks, there were 3 episodes (0.7%) of major hypoglycemia in patients treated with glipizide plus metformin and none in patients treated with FORXIGA plus metformin. Minor episodes of hypoglycemia were reported in 2.5% of patients treated with FORXIGA plus metformin and 42.4% of patients treated with glipizide plus metformin.

Add-on to sulfonylureas: In a study with FORXIGA added on to glimepiride for up to 48 weeks there was one episode of major hypoglycemia reported in a patient treated with dapagliflozin 2.5 mg plus glimepiride. Minor episodes of hypoglycemia were reported in 8.3%

and 7.9% of patients treated with FORXIGA 5 mg and 10 mg plus glimepiride, respectively, and 2.1% of patients treated with placebo plus glimepiride.

Add-on to metformin and to a sulfonylurea: In the add-on to combination study with metformin and a sulfonylurea up to 52 weeks, there were no episodes of major hypoglycemia reported. Minor episodes of hypoglycemia were reported for 15.6% of patients treated with FORXIGA 10 mg plus metformin and a sulfonylurea and 4.6% of patients treated with placebo plus metformin and a sulfonylurea.

Add-on to sitagliptin alone or with metformin: In a study of FORXIGA 10 mg added on to sitagliptin (with or without metformin) for up to 48 weeks, one major episode of hypoglycemia was reported in a patient treated with FORXIGA 10 mg plus sitagliptin (without metformin). Minor episodes of hypoglycemia were reported in 2.2% and 1.3% of patients treated with FORXIGA 10 mg or placebo added on to sitagliptin (with or without metformin), respectively.

Add-on to insulin: At Week 104, major episodes of hypoglycemia were reported in 1.4%, 1.0% and 0.5% of patients treated with FORXIGA 5 mg and 10 mg or placebo added on to insulin, respectively. Minor episodes were reported in 52.8%, 53.1% and 41.6% of patients treated with FORXIGA 5 mg or 10 mg or placebo added on to insulin, respectively. In two additional studies that also included a large proportion of patients who received insulin as background therapy (alone or with one or more oral antidiabetic treatments) (see CLINICAL TRIALS), the rate of minor episodes of hypoglycemia was also increased in patients treated with FORXIGA 10 mg compared with those treated with placebo.

CV outcomes study (DECLARE-TIMI 58): Major events of hypoglycemia were reported in 58 patients (0.7%) treated with FORXIGA 10 mg and 83 (1.0%) patients treated with placebo. Major events of hypoglycemia were reported in 52 patients (1.2%) and 64 patients (1.4%) treated with FORXIGA 10 mg or placebo added on to insulin, respectively. Major events of hypoglycemia were reported in 14 patients (0.3%) and 23 patients (0.5%) treated with FORXIGA or placebo added on to sulfonylurea, respectively. Major events of hypoglycemia leading to hospitalization occurred in 13 patients (0.2%) and 22 patients (0.3%) treated with FORXIGA or placebo, respectively.

Patients with renal impairment: Safety was also assessed in two dedicated studies of T2DM patients being treated for glycemic control, with moderate renal impairment ($eGFR \geq 45$ to <60 mL/min/1.73m² and $eGFR \geq 30$ to <60 mL/min/1.73m², respectively).

In the study of patients with $eGFR \geq 45$ to <60 mL/min/1.73m², at Week 24, FORXIGA was associated with changes in mean eGFR (FORXIGA: -3.39 mL/min/1.73m² and placebo: -0.90 mL/min/1.73m²). The mean eGFR in the dapagliflozin group decreased initially (during the first 4 weeks of treatment) and remained steady for the remaining 20 weeks of treatment. At 3 weeks after termination of FORXIGA, the mean change from baseline in eGFR in the dapagliflozin group was similar to the mean change in the placebo group (FORXIGA: 0.57 mL/min/1.73m² and placebo: -0.04 mL/min/1.73m²). A higher proportion of subjects treated with dapagliflozin had adverse reactions of hypotension, compared with placebo.

In the study of patients with eGFR ≥ 30 to < 60 mL/min/1.73m², at Week 52, FORXIGA was associated with changes from baseline in mean eGFR (eGFR: FORXIGA 5 mg: -2.08 mL/min/1.73m², FORXIGA 10 mg -4.46 mL/min/1.73m² and placebo -2.58 mL/min/1.73m²). At Week 104, these changes persisted (eGFR: FORXIGA 5 mg -1.71 mL/min/1.73m², FORXIGA 10 mg -3.50 mL/min/1.73m² and placebo -2.38 mL/min/1.73m²). With FORXIGA 5 mg and 10 mg, these eGFR reductions were evident at Week 1 while placebo treated patients had a slow continuous decline through Week 104.

Diabetic ketoacidosis in patients with diabetes: Cases of DKA, a serious life-threatening condition requiring urgent hospitalization, have been reported in patients with T2DM treated with FORXIGA and other SGLT2 inhibitors. Some cases of DKA have been fatal. FORXIGA is not indicated, and should not be used, in patients with type 1 diabetes. In some cases, the presentation of the condition was atypical, with blood glucose values only moderately elevated (< 13.9 mmol/L (250 mg/dL) (see WARNINGS AND PRECAUTIONS, Endocrine and Metabolism).

Cardiovascular Outcomes Study (DECLARE-TIMI 58)

DECLARE-TIMI 58 evaluated the safety and tolerability of FORXIGA 10 mg (n=8574) versus placebo (n=8569) in adult patients with T2DM and CV risk factors or established cardiovascular disease. The mean exposure time was 42 months. In total, there were 30623 patient-years of exposure to FORXIGA. The safety variables collected in DECLARE-TIMI 58 included: serious adverse events (SAE), adverse events leading to discontinuation of study drug (DAE), CV events, amputation events, DKA events, and adverse events of special interest. Adverse events of special interest consisted of: malignancies, hepatic events, major hypoglycemic events, fractures, renal events, symptoms of volume depletion, hypersensitivity reactions, urinary tract infections, and genital infections.

Events related to volume depletion were reported in 2.5% and 2.4% of patients in the FORXIGA and placebo groups, respectively. Serious adverse events (SAE) of volume depletion were reported in 0.9% and 0.8% of patients in the FORXIGA and placebo groups, respectively. In patients with eGFR < 60 mL/min/1.73m² at baseline, SAEs were reported in 3.1% and 2.0% of patients in the FORXIGA and placebo groups, respectively. In patients ≥ 65 years, SAEs were reported in 1.3% and 1.1% of patients in the FORXIGA and placebo groups, respectively.

Events of genital infection leading to discontinuation of study drug occurred in 0.9% and $< 0.1\%$ of patients in the FORXIGA and placebo groups, respectively. SAEs of genital infection occurred in 2 patients ($< 0.1\%$) in each of the FORXIGA and placebo groups.

Events of UTI leading to discontinuation of study drug occurred in 0.7% and 0.4% of patients in the FORXIGA and placebo groups, respectively. SAEs of UTI occurred 0.9% and 1.3% of patients in the FORXIGA and placebo groups, respectively. In patients ≥ 75 years of age, events of UTI leading to discontinuation of study drug occurred in 1.7% and 0.4% of patients in the FORXIGA and placebo groups, respectively; SAEs of UTI occurred in 2.0% and 1.4% of patients in the FORXIGA and placebo groups, respectively.

Adjudicated events of DKA were reported in 27 patients (0.3%) in the FORXIGA 10 mg group and 12 patients (0.1%) in the placebo groups (0.04 and 0.09 events per 100 patient-years, respectively). The events were evenly distributed throughout the study period. Of the 27 patients with DKA events in the FORXIGA group, 22 had concomitant insulin treatment at the time of the event.

Renal events (e.g., decreased renal creatinine clearance, renal impairment, increased blood creatinine, and decreased glomerular filtration rate) were reported in 4.9% and 6.1% of patients in the FORXIGA and placebo groups, respectively.

Events of acute kidney injury were reported in 1.5% and 2.0% of patients in the FORXIGA and placebo groups, respectively. SAEs of renal events occurred in 0.9% and 1.6% of patients in the FORXIGA and placebo groups, respectively.

Events of fractures occurred in 7.4% and 5.8% of patients ≥ 75 years of age in the FORXIGA and placebo groups, respectively.

Abnormal Hematologic and Clinical Chemistry Findings in T2DM Patients Being Treated for Glycemic Control

Increases in serum creatinine, blood urea nitrogen (BUN) and decreased eGFR: In the pool of 13 placebo-controlled studies, in FORXIGA-treated patients, mean eGFR decreased by Week 1 and then increased toward eGFR baseline values over time to Week 24.

Changes from baseline in serum creatinine were consistent with changes in eGFR. Mean serum creatinine levels increased at Week 1 and decreased toward baseline at Week 24. There were small increases in BUN. Mean BUN levels increased at Week 1 and values remained stable through Weeks 24 and 102.

Table 4 Mean Changes from Baseline for Serum Creatinine and eGFR at Week 1 and Week 24

Study Week/ Treatment Group	Week 1*		Week 24*	
	FORXIGA 10 mg	Placebo	FORXIGA 10 mg	Placebo
Serum creatinine, $\mu\text{mol/L}$ (mg/dL)				
Mean Changes from Baseline	-3.62 (-0.041) N=1112	-0.71 (-0.008) N=1057	1.68 (0.019) N=1954	0.71 (0.008) N=1844
eGFR, mL/min/1.73m²				
Mean Changes from Baseline	-4.174 N=1102	0.490 N=1048	-1.446 N=1954	-0.665 N=1844

*Pool of 13 placebo-controlled studies in patients with T2DM being treated for glycemic control

Increases in hemoglobin/hematocrit: In the pool of 13 placebo-controlled studies, increases from baseline in mean hemoglobin values were observed and increases from baseline in mean hematocrit values were observed in FORXIGA-treated patients starting at Week 1 and continuing up to Week 16, when the maximum mean difference from baseline was observed. The mean changes from baseline in hemoglobin and hematocrit at Weeks 24 and 102 are presented below.

Table 5 Mean Changes from Baseline for Hemoglobin and Hematocrit at Week 24 and Week 102

Study Week/ Treatment Group	Week 24*		Week 102**	
	FORXIGA 10 mg	Placebo	FORXIGA 10 mg	Placebo
Hemoglobin, g/L (g/dL)				
Mean Changes from Baseline	6.21 (0.621) N=1934	- 1.38 (-0.138) N=1828	7.0 (0.70) N=621	-2.1 (-0.21) N=515
Hematocrit, %				
Mean Changes from Baseline	2.30 N=1908	-0.33 N=1796	2.68 N=616	-0.46 N=510

*Pool of 13 placebo-controlled studies in patients with T2DM being treated for glycemic control

**Pool of 9 placebo-controlled studies in patients with T2DM being treated for glycemic control

By Week 24, hematocrit values >55% were reported in 1.3% of FORXIGA 10 mg-treated patients vs. 0.4% of placebo-treated patients. Results were similar during the short-term plus long-term phase (the majority of patients were exposed to treatment for more than one year).

Increases in serum inorganic phosphorus: In the pool of 13 placebo-controlled studies, increases from baseline in mean serum phosphorus levels were reported at Week 24 in FORXIGA 10 mg-treated patients compared with placebo-treated patients. Similar results were seen at Week 102 (see below). Higher proportions of patients with marked laboratory abnormalities of hyperphosphatemia were reported in FORXIGA 10 mg group vs. placebo at Week 24 and during the short-term plus long-term phase. The clinical relevance of these findings is unknown.

Table 6 Mean Changes from Baseline for Serum Inorganic Phosphorus and Proportion of Patients with Hyperphosphatemia at Week 24 and Week 102

Study Week/ Treatment Group	Week 24*		Week 102**	
	FORXIGA 10 mg	Placebo	FORXIGA 10 mg	Placebo
Serum Inorganic Phosphorus, µmol/L (mg/dL)				

Mean Changes from Baseline	42.0 (0.13) N=1954	-12.9 (-0.04) N=1844	38.7 (0.12) N=627	6.5 (0.02) N=522
Hyperphosphatemia[†]				
Proportion of Patients	1.7% N=1178	0.7% N=1381	3.0% N=2001	1.6% N=1940

*Pool of 13 placebo-controlled studies in patients with T2DM being treated for glycemic control

**Pool of 9 placebo-controlled studies in patients with T2DM being treated for glycemic control

[†]Defined as ≥ 1.81 mmol/L (≥ 5.6 mg/dL) if age 17 - 65 or ≥ 1.65 mmol/L (≥ 5.1 mg/dL) if \geq age 66

Lipids: In the pool of 13 placebo-controlled studies, increases from baseline were noted in levels of total cholesterol, LDL- and HDL-cholesterol, and decreases from baseline were noted for triglycerides at Week 24 and Week 102 in FORXIGA 10 mg-treated patients compared with placebo-treated patients (see below).

Table 7 Mean Changes from Baseline for Lipid Parameters at Week 24 and Week 102

Study Week/ Treatment Group	Week 24*		Week 102**	
	FORXIGA 10 mg	Placebo	FORXIGA 10 mg	Placebo
Mean Percent Changes from Baseline				
Total Cholesterol	2.5% N=1851	0.0% N=1747	2.1% N=550	-1.5% N=446
HDL-cholesterol	6.0% N=1851	2.7% N=1748	6.6% N=549	2.1% N=447
LDL-cholesterol	2.9% N=1840	-1.0% N=1736	2.9% N=542	-2.2% N=442
Triglycerides	-2.7% N=1844	-0.7% N=1736	-1.8% N=545	-1.8% N=444

*Pool of 13 placebo-controlled studies in patients with T2DM being treated for glycemic control

**Pool of 9 placebo-controlled studies in patients with T2DM being treated for glycemic control

The ratio between LDL-cholesterol and HDL-cholesterol decreased for both treatment groups at Week 24 and at Week 102.

Clinical Trial in Patients with Heart Failure (DAPA-HF)

The DAPA-HF study (see CLINICAL TRIALS) was a dedicated CV outcomes study in adult patients with HFrEF which assessed the safety and tolerability of FORXIGA 10 mg, as add-on to standard of care therapy for heart failure. These data reflect exposure of 2368 patients to

FORXIGA 10 mg and a median exposure time of 18 months. In total, there were 3310 patient-years of exposure to FORXIGA.

The DAPA-HF study included 1926 (41%) patients with eGFR below 60 mL/min/1.73m² and 719 (15%) with eGFR below 45 mL/min/1.73m². No overall differences in safety were seen in these patients compared to patients with normal renal function.

There were 2714 (57%) out of 4744 patients older than 65 years with HF_rEF included in the DAPA-HF study. Safety was similar for patients age 65 years and younger and those older than 65. There was no increased risk in events of volume depletion or acute kidney injury.

The number of patients with events related to volume depletion (including reports of hypotension, hypovolemia, dehydration, or orthostatic hypotension) were 170 (7.2%) and 153 (6.5%) in the FORXIGA-treated and placebo groups, respectively. Serious events of symptoms suggestive of volume depletion were reported in 23 (1.0%) patients in the FORXIGA-treated group and in 38 (1.6%) patients in the placebo group.

The number of patients with renal adverse events were 141 (6.0%) and 158 (6.7%) in the FORXIGA-treated and the placebo group, respectively. Serious renal adverse events were reported in (1.4%) patients in the FORXIGA-treated group and 58 (2.4%) patients in the placebo group.

Severe hypoglycemia and DKA events were observed only in patients with T2DM. The number of patients with severe hypoglycemia events were 4 (0.2%) in the FORXIGA-treated and 4 (0.2%) in the placebo group. The number of patients with DKA events were 3 (0.1%) in the FORXIGA-treated group and none in the placebo group.

There were no patients with serious events of genital infections in the FORXIGA-treated group and one in the placebo group. There were 7 (0.3%) patients with adverse events leading to discontinuations of study treatment due to genital infections in the FORXIGA-treated group and none in the placebo group.

There were 14 (0.6%) patients with serious events of urinary tract infections in the FORXIGA-treated group and 17 (0.7%) patients in the placebo group. There were 5 (0.2%) patients with adverse events leading to discontinuations of study treatment due to urinary tract infections in the FORXIGA-treated group and 5 (0.2%) patients in the placebo group.

Post-Market Adverse Drug Reactions

The following adverse reactions have been identified during post-approval use of FORXIGA in patients with T2DM. Because these reactions are reported voluntarily from a population of uncertain size, it is generally not possible to reliably estimate their frequency or establish a causal relationship to drug exposure.

Genitourinary: severe urinary tract infections; urosepsis and pyelonephritis

Hepatic/Biliary/Pancreatic: acute pancreatitis

Infection and Infestations: necrotizing fasciitis of the perineum (Fournier’s gangrene) (see (WARNINGS AND PRECAUTIONS, Genitourinary)

Metabolism: diabetic ketoacidosis

Renal and urinary disorders: acute kidney injury, including acute renal failure

Skin and subcutaneous tissue disorders: rash (including rash generalized, rash pruritic, rash macular, rash macular-papular, rash pustular and rash vesicular)

DRUG INTERACTIONS

Overview

In vitro assessment of interactions

The metabolism of dapagliflozin is primarily mediated by UGT1A9-dependent glucuronide conjugation. The major metabolite, dapagliflozin 3-O-glucuronide, is not an SGLT2 inhibitor.

In *in vitro* studies, dapagliflozin and dapagliflozin 3-O-glucuronide neither inhibited CYP 1A2, 2C9, 2C19, 2D6, 3A4, nor induced CYP1A2, 2B6 or 3A4. Dapagliflozin is a weak substrate of the P-glycoprotein (P-gp) active transporter and dapagliflozin 3-O-glucuronide is a substrate for the OAT3 active transporter. Dapagliflozin or dapagliflozin 3-O-glucuronide did not meaningfully inhibit P-gp, OCT2, OAT1, or OAT3 active transporters. Overall, dapagliflozin is unlikely to affect the pharmacokinetics of concurrently administered medications that are P-gp, OCT2, OAT1, or OAT3 substrates.

Drug-Drug Interactions

Pharmacokinetic interactions

Effect of other drugs on dapagliflozin: In studies conducted in healthy subjects, the pharmacokinetics of dapagliflozin were not altered by the coadministered drugs (see Table 8).

Table 8 Effects of Coadministered Drugs on Dapagliflozin Systemic Exposure

Coadministered Drug (Dose Regimen)*	Dapagliflozin (Dose Regimen)*	Effect on Dapagliflozin Exposure Ratio of Adjusted Geometric Means (90% CI)		Clinical Comment
		C _{max}	AUC [†]	
Oral Antidiabetic Agents				
Metformin (1000 mg)	20 mg	0.932 (0.848, 1.024)	0.995 (0.945, 1.053)	No dosing adjustment required
Pioglitazone (45 mg)	50 mg	1.09 (1.00, 1.18)	1.03 (0.98, 1.08)	No dosing adjustment required

Table 8 Effects of Coadministered Drugs on Dapagliflozin Systemic Exposure

Coadministered Drug (Dose Regimen)*	Dapagliflozin (Dose Regimen)*	Effect on Dapagliflozin Exposure Ratio of Adjusted Geometric Means (90% CI)		Clinical Comment
		C _{max}	AUC [†]	
Sitagliptin (100 mg)	20 mg	0.958 (0.875, 1.049)	1.081 (1.031, 1.133)	No dosing adjustment required
Glimepiride (4 mg)	20 mg	1.006 (0.921, 1.097)	0.989 (0.958, 1.020)	No dosing adjustment required
Voglibose (0.2 mg three times daily)	10 mg	1.040 (0.899, 1.204)	1.009 (0.954, 1.067)	No dosing adjustment required
Other Medications				
Hydrochlorothiazide (25 mg)	50 mg	NC	1.07 (1.04, 1.11)	No dosing adjustment required
Bumetanide (1 mg)	10 mg once daily for 7 – 14 days	1.080 (0.953, 1.222)	1.047 (0.991, 1.106)	No dosing adjustment required
Valsartan (320 mg)	20 mg	0.881 (0.796, 0.975)	1.024 (1.000, 1.049)	No dosing adjustment required
Simvastatin (40 mg)	20 mg	0.978 (0.887, 1.078)	0.986 (0.957, 1.017)	No dosing adjustment required
Mefenamic acid (250 mg every 6 hours)	10 mg	1.13 (1.03, 1.24)	1.51 (1.44, 1.58)	No dosing adjustment required
Anti-infective Agent				
Rifampin (600 mg once daily for 6 days)**	10 mg	0.931 (0.779, 1.112)	0.780 (0.731, 0.832)	No dosing adjustment required

* Single dose unless otherwise noted.

NC No apparent change, ratio and 90% CI were not calculated.

† AUC = AUC(INF) for drugs given as single dose and AUC = AUC(TAU) for drugs given in multiple doses.

** The mean amount of glucose excreted in the urine over 24 h following administration of dapagliflozin alone (51 g) was not markedly affected by rifampin coadministration (45 g).

Effect of dapagliflozin on other drugs: In studies conducted in healthy subjects, as described below, dapagliflozin did not alter the pharmacokinetics of the coadministered drugs (see Table 9).

Table 9 Effects of Dapagliflozin on the Systemic Exposures of Coadministered Drugs

Coadministered Drug (Dose Regimen)*	Dapagliflozin (Dose Regimen)*	Effect on Coadministered Drug Exposure Ratio of Adjusted Geometric Means (90% CI)		Clinical Comment
		C _{max}	AUC [†]	
Oral Antidiabetic Agents				
Metformin (1000 mg)	20 mg	0.953 (0.866, 1.049)	1.001 (0.933, 1.075)	No dosing adjustment required
Pioglitazone (45 mg)	50 mg	0.93 (0.75, 1.15)	1.00 (0.90, 1.13)	No dosing adjustment required
Sitagliptin (100 mg)	20 mg	0.887 (0.807, 0.974)	1.012 (0.985, 1.040)	No dosing adjustment required
Glimepiride (4 mg)	20 mg	1.043 (0.905, 1.201)	1.132 (0.996, 1.287)	No dosing adjustment required
Other Medications				
Hydrochlorothiazide (25 mg)	50 mg	NC	0.99 (0.95, 1.04)	No dosing adjustment required
Bumetanide (1 mg)**	10 mg once daily for 7 days	1.132 (0.979, 1.310)	1.132 (0.985, 1.302)	No dosing adjustment required
Valsartan (320 mg)	20 mg	0.938 (0.762, 1.156)	1.046 (0.850, 1.286)	No dosing adjustment required
Simvastatin (40 mg)	20 mg	0.936 (0.816, 1.073)	1.193 (1.018, 1.399)	No dosing adjustment required
Digoxin (0.25 mg)	20 mg loading dose then 10 mg once daily for 7 days	0.990 (0.843, 1.162)	1.002 (0.860, 1.167)	No dosing adjustment required
Warfarin (25 mg)***	20 mg loading dose then	S-warfarin		No dosing

Table 9 Effects of Dapagliflozin on the Systemic Exposures of Coadministered Drugs

Coadministered Drug (Dose Regimen)*	Dapagliflozin (Dose Regimen)*	Effect on Coadministered Drug Exposure Ratio of Adjusted Geometric Means (90% CI)		Clinical Comment
		C _{max}	AUC [†]	
	10 mg once daily for 7 days	1.030 (0.994, 1.124)	1.068 (1.002, 1.138)	adjustment required
		R-warfarin		
		1.057 (0.977, 1.145)	1.079 (1.030, 1.130)	

* Single dose unless otherwise noted.

NC No apparent change, ratio and 90% CI were not calculated.

† AUC = AUC(INF) for drugs given as single dose and AUC = AUC(TAU) for drugs given in multiple doses.

** Coadministration of dapagliflozin did not meaningfully alter the steady-state pharmacodynamic responses (urinary sodium excretion, urine volume) to bumetanide in healthy subjects.

*** Dapagliflozin also did not affect the anticoagulant activity of warfarin as measured by the prothrombin time (International Normalized Ratio; [INR]).

Pharmacodynamic interactions

Diuretics: FORXIGA may add to the diuretic effect of loop diuretics and may increase the risk of dehydration and hypotension (see WARNINGS AND PRECAUTIONS).

Drug-Food Interactions

Interactions with food have not been studied (see DOSAGE AND ADMINISTRATION, Dosing Considerations).

Drug-Herb Interactions

The effects of herbal products on the pharmacokinetics of dapagliflozin have not been studied.

Drug-Laboratory Interactions

Due to its mechanism of action, patients taking FORXIGA will test positive for glucose in their urine. Monitoring glycemic control with 1,5-AG assay is not recommended as measurements of 1,5-AG are unreliable in assessing glycemic control in patients taking SGLT2 inhibitors. Use alternative methods to monitor glycemic control.

Drug-Lifestyle Interactions

The effects of smoking, diet, and alcohol use on the pharmacokinetics of dapagliflozin have not been specifically studied.

No studies on the effects on the ability to drive and use machines have been performed. However, patients should be alerted to the elevated risk of adverse reactions related to reduced intravascular volume, such as postural dizziness, and to the risk of hypoglycemia when FORXIGA is used as add-on therapy with insulin or an insulin secretagogue.

DOSAGE AND ADMINISTRATION

Dosing Considerations

Concomitant use with insulin or an insulin secretagogue (e.g., sulfonylurea): When FORXIGA is used as add-on therapy with insulin or an insulin secretagogue (e.g., sulfonylurea), a lower dose of insulin or the insulin secretagogue may be considered to reduce the risk of hypoglycemia (see WARNINGS AND PRECAUTIONS and ADVERSE REACTIONS).

Recommended Dose and Dosage Adjustment

Type 2 Diabetes Mellitus

To improve glycemic control, the recommended starting dose of FORXIGA is 5 mg taken once daily at any time of the day with or without food. In patients tolerating FORXIGA 5 mg once daily and who require additional glycemic control, the dose can be increased to 10 mg daily.

To reduce the risk of hospitalization due to HF, the recommended dose of FORXIGA is 10 mg once daily.

In patients with evidence of volume depletion, this condition should be corrected prior to initiation of FORXIGA (see WARNINGS AND PRECAUTIONS).

Heart Failure (DAPA-HF)

To reduce the risk of CV death, hospitalization for HF and urgent HF visit in patients with HFrEF, the recommended dose of FORXIGA is 10 mg taken orally once daily at any time of the day regardless of meals.

In the DAPA-HF study, FORXIGA was used in conjunction with other heart failure therapies.

Renal impairment:

Type 2 Diabetes Mellitus

The glycemic efficacy of FORXIGA is dependent on renal function and declines with decreasing renal function. Renal function should be assessed prior to initiation of FORXIGA therapy and periodically thereafter, with more intensive monitoring of glycemic and renal biomarkers, and signs and symptoms of renal dysfunction in patients whose eGFR decreases $<60 \text{ mL}/\text{min}/1.73\text{m}^2$. No dosage adjustment for FORXIGA is required in T2DM patients, who

are being treated for glycemic control, with mild to moderate (CKD 3A) renal impairment (eGFR \geq 45 mL/min/1.73m²).

FORXIGA is not recommended for use in patients with T2DM, being treated for glycemic control, with an eGFR persistently <45 mL/min/1.73m², severe renal impairment, ESRD, or patients on dialysis as the glycemic efficacy of dapagliflozin is dependent on renal function (see ADVERSE REACTIONS and CLINICAL TRIALS). FORXIGA is contraindicated in patients with an eGFR less than 30 mL/min/1.73m², end-stage renal disease (ESRD) or patients on dialysis (see CONTRAINDICATIONS).

Heart Failure (DAPA-HF)

No dosage adjustment is required based on renal function. FORXIGA is contraindicated in patients with an eGFR less than 30 mL/min/1.73m², end-stage renal disease (ESRD) or patients on dialysis (see CONTRAINDICATIONS).

Hepatic impairment: No dosage adjustment for FORXIGA is necessary for patients with mild or moderate hepatic impairment. FORXIGA exposure is increased in patients with severe hepatic impairment (see ACTION AND CLINICAL PHARMACOLOGY, Pharmacokinetics). Therefore, FORXIGA is not recommended for use in this population.

Pediatrics (<18 years of age): Safety and effectiveness of FORXIGA in pediatric and adolescent patients have not been established. Therefore, FORXIGA should not be used in this population.

Geriatrics (\geq 65 years of age): No dosage adjustment for FORXIGA is required based on age; however renal function and risk of volume depletion should be taken into account (see WARNINGS AND PRECAUTIONS).

Missed Dose

If a dose of FORXIGA is missed, it should be taken as soon as the patient remembers. A double dose of FORXIGA should not be taken on the same day.

OVERDOSAGE

It is reasonable to employ supportive measures, as dictated by the patient's clinical status. The removal of dapagliflozin by hemodialysis has not been studied.

For management of a suspected drug overdose, contact your regional Poison Control Centre.

ACTION AND CLINICAL PHARMACOLOGY

Mechanism of Action

Dapagliflozin is a reversible inhibitor of sodium-glucose co-transporter 2 (SGLT2) that improves glycemic control in patients with T2DM by reducing renal glucose reabsorption leading to urinary excretion of excess glucose (glucuresis) and provides cardiovascular benefits.

Type 2 Diabetes Mellitus

SGLT2 is selectively expressed in the kidney. SGLT2 is the predominant transporter responsible for reabsorption of glucose from the glomerular filtrate back into the circulation. Dapagliflozin improves both fasting and post-prandial plasma glucose levels by reducing renal glucose reabsorption leading to urinary excretion of excess glucose. The amount of glucose removed by the kidney through this mechanism is dependent upon the blood glucose concentration and GFR. Dapagliflozin does not impair normal endogenous glucose production in response to hypoglycemia. Dapagliflozin acts independently of insulin secretion and insulin action.

Urinary glucose excretion (glucuresis) induced by dapagliflozin is associated with caloric loss and reduction in weight. Inhibition of glucose and sodium co-transport by dapagliflozin is also associated with mild diuresis and transient natriuresis.

Dapagliflozin does not inhibit other glucose transporters important for glucose transport into peripheral tissues and is greater than 1400 times more selective for SGLT2 vs. SGLT1, the major transporter in the gut responsible for glucose absorption.

Heart Failure (DAPA-HF)

Dapagliflozin increases the delivery of sodium to the distal tubule which is believed to increase tubuloglomerular feedback and reduce intraglomerular pressure. Secondary effects of SGLT2 inhibition with dapagliflozin also include a modest reduction in blood pressure, reduction in body weight, and an increase in hematocrit.

The cardiovascular benefits of dapagliflozin are not solely dependent on the blood glucose-lowering effect and not limited to patients with diabetes.

Pharmacodynamics

Increases in the amount of glucose excreted in the urine were observed in healthy subjects and in patients with T2DM following the administration of dapagliflozin. Approximately 70 g of glucose was excreted in the urine per day (corresponding to 280 kcal/day) at a dapagliflozin dose of 10 mg/day in patients with T2DM for 12 weeks. This glucose elimination rate approached the maximum glucose excretion observed at 20 mg/day of dapagliflozin. Evidence of sustained glucose excretion was seen in patients with T2DM given dapagliflozin 10 mg/day for up to 2 years.

This urinary glucose excretion with dapagliflozin also results in osmotic diuresis and increases in urinary volume. Urinary volume increases in patients with T2DM treated with FORXIGA 10 mg were sustained at 12 weeks and amounted to approximately 375 mL/day. The increase in urinary volume was associated with a small and transient increase in urinary sodium excretion that was not associated with changes in serum sodium concentrations.

Urinary uric acid excretion was also increased transiently (for 3-7 days) and accompanied by a reduction in serum uric acid concentration. At 24 weeks, reductions in serum uric acid concentrations ranged from 18.3 to 48.3 $\mu\text{mol/L}$ (0.33 mg/dL to 0.87 mg/dL).

N-terminal pro-B-type natriuretic peptide (NT-proBNP): In the DAPA-HF study (see CLINICAL TRIALS), the mean change from baseline for NT-proBNP at 8 months was -196 pg/mL in the FORXIGA-treated group and 101 pg/mL in the placebo group.

Cardiac electrophysiology: In a double-blind, randomized, placebo- and positive-controlled crossover study, single oral doses of dapagliflozin 20 mg and 150 mg were not associated with clinically or statistically significant effects on the QTc interval, the QRS duration, the PR interval, or heart rate in healthy subjects (n=36).

Pharmacokinetics

Absorption: Dapagliflozin was rapidly and well absorbed after oral administration and can be administered with or without food. Geometric mean steady-state dapagliflozin C_{max} and AUC_τ values following once daily 10 mg doses of dapagliflozin were 158 ng/mL and 628 ng.h/mL, respectively. Maximum dapagliflozin plasma concentrations (C_{max}) were usually attained within 2 hours after administration in the fasted state. The C_{max} and AUC values increased proportionally to the increment in dapagliflozin dose. The absolute oral bioavailability of dapagliflozin following the administration of a 10 mg dose is 78%. Food had relatively modest effects on the pharmacokinetics of dapagliflozin in healthy subjects. Administration with a high-fat meal decreased dapagliflozin C_{max} by up to 50% and prolonged T_{max} by approximately 1 hour, but did not alter AUC as compared with the fasted state. These changes are not considered to be clinically meaningful.

Distribution: Dapagliflozin is approximately 91% protein bound. Protein binding was not altered in various disease states (e.g., renal or hepatic impairment).

Metabolism: Dapagliflozin is a C-linked glucoside, meaning the aglycone component is attached to glucose by a carbon-carbon bond, thereby conferring stability against glucosidase enzymes. The mean plasma terminal half-life (t_{1/2}) for dapagliflozin was 12.9 hours following a single oral dose of FORXIGA 10 mg to healthy subjects. Dapagliflozin is extensively metabolized, primarily to yield dapagliflozin 3-O-glucuronide, which is an inactive metabolite. Dapagliflozin 3-O-glucuronide accounted for 61% of a 50 mg [¹⁴C]-dapagliflozin dose and was the predominant drug-related component in human plasma, accounting for 42% (based on AUC_[0-12 h]) of total plasma radioactivity, similar to the 39% contribution by parent drug. Based on AUC, no other metabolite accounted for >5% of the total plasma radioactivity at any time point measured. Dapagliflozin 3-O-glucuronide or other metabolites do not

contribute to the glucose-lowering effects. The formation of dapagliflozin 3-O-glucuronide is mediated by UGT1A9, an enzyme present in the liver and kidney, and CYP-mediated metabolism was a minor clearance pathway in humans.

Excretion: Dapagliflozin and related metabolites are primarily eliminated via urinary excretion, of which less than 2% is unchanged dapagliflozin. After administration of 50 mg [¹⁴C]-dapagliflozin dose, 96% was recovered, 75% in urine and 21% in feces. In feces, approximately 15% of the dose was excreted as parent drug.

Special Populations and Conditions

Pediatrics (<18 years of age): Pharmacokinetics in the pediatric and adolescent population have not been studied.

Age: No dosage adjustment for dapagliflozin is recommended on the basis of age. The effect of age (young: ≥ 18 to < 40 years [n=105] and elderly: ≥ 65 years [n=224]) was evaluated as a covariate in a population pharmacokinetic model and compared to patients ≥ 40 to < 65 years using data from healthy subject and T2DM patient studies). The mean dapagliflozin systemic exposure (AUC) in young patients was estimated to be 10.4% lower than in the reference group (90% CI: 87.9, 92.2%) and 25% higher in elderly patients compared to the reference group (90% CI: 123, 129%). These differences in systemic exposure were considered not to be clinically meaningful.

Gender: No dosage adjustment is recommended for dapagliflozin on the basis of gender. Gender was evaluated as a covariate in a population pharmacokinetic model using data from healthy subject and T2DM patient studies. The mean dapagliflozin AUC_{ss} in females (n=619) was estimated to be 22% higher than in males (n=634) (90% CI: 117,124).

Race: No dosage adjustment is recommended on the basis of race. Race (white, black or Asian) was evaluated as a covariate in a population pharmacokinetic model using data from healthy subject and T2DM patient studies. Differences in systemic exposures between these races were small. Compared to whites (n=1147), Asian subjects (n=47) had no difference in estimated mean dapagliflozin systemic exposures (90% CI range 3.7% lower, 1% higher). Compared to whites, black subjects (n=43) had 4.9% lower estimated mean dapagliflozin systemic exposures (90% CI range 7.7% lower, 3.7% lower).

Body weight: No dose adjustment is recommended on the basis of weight. In a population pharmacokinetic analysis using data from healthy subject and T2DM patient studies, systemic exposures in high body weight subjects (≥ 120 kg, n=91) were estimated to be 78.3% (90% CI: 78.2, 83.2%) of those of reference subjects with body weight between 75 and 100 kg. No dose adjustment from the proposed dose of 10 mg dapagliflozin once daily in T2DM patients with high body weight (≥ 120 kg) is recommended. Subjects with low body weights (< 50 kg) were not well represented in the healthy subject and patient studies used in the population pharmacokinetic analysis. Therefore, dapagliflozin systemic exposures were simulated with a large number of subjects. The simulated mean dapagliflozin systemic exposures in low body weight subjects were estimated to be 29% higher than subjects with the reference group body

weight. Based on these findings no dose adjustment from the proposed dose of 10 mg dapagliflozin once daily in T2DM patients with low body weight (<50 kg) is recommended.

Renal impairment: FORXIGA is not recommended for use in patients with T2DM, being treated for glycemic control, with an eGFR persistently <45 mL/min/1.73m², severe renal impairment, ESRD, or patients on dialysis as the glycemic efficacy of dapagliflozin is dependent on renal function (see WARNINGS AND PRECAUTIONS, ADVERSE REACTIONS, DOSAGE AND ADMINISTRATION, and CLINICAL TRIALS). FORXIGA is contraindicated in patients with an eGFR less than 30 mL/min/1.73m², ESRD or patients on dialysis (see CONTRAINDICATIONS).

At steady-state (20 mg once-daily dapagliflozin for 7 days), patients with T2DM and mild, moderate or severe renal impairment (as determined by iohexol clearance) had mean systemic exposures of dapagliflozin that were 32%, 60% and 87% higher, respectively, than those of patients with T2DM and normal renal function. Higher systemic exposures to dapagliflozin in patients with T2DM and renal impairment did not result in a correspondingly higher renal glucose clearance or total cumulative glucose excretion. The renal glucose clearance and 24-hour glucose excretion were lower in patients with moderate or severe renal impairment as compared to patients with normal and mild renal impairment. The steady-state 24-hour urinary glucose excretion was highly dependent on renal function and 85, 52, 18 and 11 g of glucose/day was excreted by patients with T2DM and normal renal function or mild, moderate or severe renal impairment, respectively. There were no differences in the protein binding of dapagliflozin between renal impairment groups or compared to healthy subjects. The impact of hemodialysis on dapagliflozin exposure is not known.

Hepatic impairment: A single dose (10 mg) dapagliflozin clinical pharmacology study was conducted in patients with mild, moderate or severe hepatic impairment (Child-Pugh classes A, B, and C, respectively) and healthy matched controls. There were no differences in the protein binding of dapagliflozin between patients with hepatic impairment compared to healthy subjects. In patients with mild or moderate hepatic impairment mean C_{max} and AUC of dapagliflozin were up to 12% and 36% higher, respectively, compared to healthy matched control subjects. No dose adjustment from the proposed usual dose of dapagliflozin is proposed for these populations. In patients with severe hepatic impairment (Child-Pugh class C) mean C_{max} and AUC of dapagliflozin were up to 40% and 67% higher than matched healthy controls, respectively.

STORAGE AND STABILITY

Store at room temperature (15-30°C).

SPECIAL HANDLING INSTRUCTIONS

Store in a safe place and out of the reach of children.

DOSAGE FORMS, COMPOSITION AND PACKAGING

Dosage Forms and Packaging

FORXIGA 5 mg tablets are yellow, biconvex, round, film coated tablets with “5” engraved on one side and “1427” engraved on the other side.

FORXIGA (dapagliflozin) 10 mg tablets are yellow, biconvex, diamond, film coated tablets with “10” engraved on one side and “1428” engraved on the other side.

The 5 mg and 10 mg tablets are provided in blisters in cartons of 30.

Information for the patient is provided as a package insert in the FORXIGA packages.

Composition

FORXIGA is available as a film-coated tablet for oral administration containing the equivalent of 5 mg or 10 mg dapagliflozin as dapagliflozin propanediol monohydrate.

Each film-coated tablet of FORXIGA also contains the following inactive ingredients: anhydrous lactose, crospovidone, magnesium stearate, microcrystalline cellulose, silicon dioxide. In addition, the film coating contains the following inactive ingredients: polyvinyl alcohol, titanium dioxide, polyethylene glycol, talc and yellow iron oxide.

PART II: SCIENTIFIC INFORMATION

PHARMACEUTICAL INFORMATION

Drug Substance

Common Name:	dapagliflozin propanediol monohydrate
Chemical Name:	D-glucitol, 1,5-anhydro-1-C-[4-chloro-3-[(4-ethoxyphenyl)methyl]phenyl]-, (1 <i>S</i>)-,compd. with (2 <i>S</i>)-1,2-propanediol, hydrate (1:1:1)
Molecular Formula and Molecular Mass:	$C_{21}H_{25}ClO_6 \cdot C_3H_8O_2 \cdot H_2O$ 502.98; 408.87 (dapagliflozin)

Structural Formula:

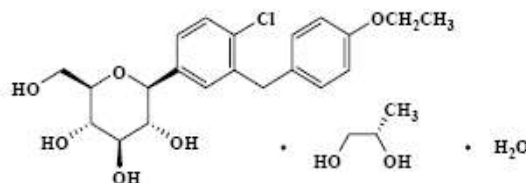

Physicochemical Properties:

Dapagliflozin propanediol is a white to off-white non-hygroscopic crystalline powder. It is slightly soluble in water, soluble in acetonitrile and freely soluble in acetone, ethanol, isopropanol, methanol and tetrahydrofuran.

CLINICAL TRIALS

Clinical Trials in Patients with T2DM Treated for Glycemic Control

FORXIGA (dapagliflozin) was studied as monotherapy and in combination with other antidiabetic medications, including metformin, glimepiride, or insulin. FORXIGA was also studied in patients with T2DM and CV disease and in patients with mild to moderate renal impairment.

Treatment with FORXIGA as monotherapy and in combination with metformin, glimepiride, or insulin produced clinically relevant and statistically significant improvements in mean change from baseline at Week 24 in HbA1c, fasting plasma glucose (FPG), and 2-hour post-prandial glucose (PPG) (where measured), compared to placebo or control. The estimated, placebo-adjusted, HbA1c reduction across trials and doses ranged from 0.40% to 0.84%. These glycemic effects were sustained in long-term extensions up to 104 weeks. HbA1c reductions were seen across subgroups including gender, age, race, duration of disease, and

baseline body mass index (BMI). In addition, patients treated with FORXIGA compared to placebo or control achieved greater HbA1c reductions in patients with a baseline HbA1c $\geq 9\%$.

A large CV outcomes study (DECLARE-TIMI 58) assessed the effect of dapagliflozin on CV outcomes in patients with T2DM with and without established CV disease. Treatment with dapagliflozin 10 mg once daily resulted in a statistically significant and clinically relevant reduction in the risk of hospitalization for HF in patients with type 2 diabetes with and without established CV disease.

Clinical Trial in Patients with Heart Failure (DAPA-HF)

The effect of FORXIGA 10 mg once daily versus placebo, on top of standard of care, on CV death, hospitalization for heart failure (HF) and urgent HF visits in patients with HFrEF (New York Heart Association [NYHA] II-IV) was assessed in a Phase III study. FORXIGA demonstrated a statistically significant reduction in the incidence of the primary composite endpoint of CV death, hospitalization for heart failure or urgent heart failure visit compared with placebo, with all three components individually contributing to the treatment effect.

Study demographics and trial design

Table 10 Summary of patient demographics for clinical trials in specific indications

Study #	Trial design	Dosage, route of administration and duration	N per group/ N treated with dapagliflozin/ Total	Mean age	Gender (% M/F)
Clinical Trials in Patients with T2DM Treated for Glycemic Control					
Monotherapy					
1	Multicentre, randomized, double-blind, placebo-controlled	<u>Group 1:</u> dapagliflozin 2.5, 5 or 10 mg, QAM or QPM, vs. placebo Oral, 24 weeks + 78 weeks	64 - 76/ 410/ 485 (ST)	52.6	47/53
		<u>Group 2:</u> dapagliflozin 5 or 10 mg, QAM Oral, 24 weeks + 78 weeks	34, 39/ 73/ 73 (ST)	48.1	64/36
Add-on Combination Therapy with Metformin					
2	Multicentre, randomized, double-blind, placebo-controlled	4 groups: dapagliflozin 2.5, 5, or 10 mg or placebo Background therapy: metformin ≥ 1500 mg/day Oral, 24 weeks + 78 weeks	135 - 137/ 409/ 546 (ST)	53.9	53/47

Study #	Trial design	Dosage, route of administration and duration	N per group/ N treated with dapagliflozin/ Total	Mean age	Gender (% M/F)
3	Multicentre, randomized, double-blind, active-controlled	2 groups: dapagliflozin titrated dose of 2.5, 5, or 10 mg or glipizide titrated dose of 5, 10, or 20 mg Background therapy: metformin \geq 1500 mg Oral, 52 weeks + 52 weeks + 52 weeks	406 - 408/ 406/ 814 (ST)	58.4	55/45
Add-on Combination Therapy with a Sulfonylurea					
4	Multicentre, randomized, double-blind, placebo-controlled	4 groups: dapagliflozin 2.5, 5, or 10 mg or placebo Background therapy: glimepiride 4 mg/day Oral, 24 weeks + 24 weeks	146 - 154/ 450/ 596 (ST)	59.8	48/52
Add-on Combination Therapy with Metformin and a Sulfonylurea					
5	Multicentre, randomized, double-blind, placebo-controlled	2 groups: dapagliflozin 10 mg or placebo Background therapy: metformin \geq 1500 mg and a sulfonylurea (at maximum tolerated dose and \geq 50% of maximum recommended dose) Oral, 24 weeks + 28 weeks	109/ 109/ 218 (ST)	61.0	49/51
Add-on Combination Therapy with Sitagliptin Alone or with Metformin					
6	Multicentre, randomized, double-blind, placebo-controlled	2 groups: dapagliflozin 10 mg or placebo Background therapy: Sitagliptin 100 mg/day (+/- metformin \geq 1500 mg) Oral, 24 weeks + 24 weeks	225 - 226/ 225/ 451 (ST)	55.0	55/45
Add-on Combination Therapy with Insulin					
7	Multicentre, randomized, double-blind, placebo-controlled	4 groups: dapagliflozin 2.5, 5, or 10 mg or placebo Background therapy: insulin \geq 30 IU/day \pm maximum 2 OAD In LT, forced titration of dapagliflozin 5 mg to 10 mg Oral, 24 weeks + 24 weeks + 56 weeks	196 - 212/ 610/ 807 (ST)	59.3	48/52
Cardiovascular Outcomes in Patients with T2DM					

Study #	Trial design	Dosage, route of administration and duration	N per group/ N treated with dapagliflozin/ Total	Mean age	Gender (% M/F)
8	Multicentre, randomized, double-blind, placebo-controlled	2 groups: dapagliflozin 10 mg or placebo Oral, mean follow-up time of 4.1 years	8578-8582/ 8582/ 17160	63.9	63/37
Clinical Trial in Patients with Heart Failure					
9	Multicentre, randomized, double-blind, placebo-controlled	Dapagliflozin 10 mg or placebo	2373 – 2371/ 2368/ 4744	66	77/23

LT = long-term; OAD = Oral anti-diabetic drug; QAM = once in the morning; QPM = once in the evening; ST = short-term

Study results

Clinical Trials in Patients with T2DM Treated for Glycemic Control

Monotherapy (Study 1)

The efficacy and safety of FORXIGA as monotherapy was evaluated in a double-blind, placebo-controlled study of 24 weeks duration in treatment-naïve patients. Following a 2-week diet and exercise placebo lead-in period, 485 patients with HbA1c $\geq 7\%$ and $\leq 10\%$ were randomized to dapagliflozin 2.5 mg, FORXIGA 5 mg, or 10 mg once daily in either the morning (QAM, main cohort) or evening (QPM), or placebo in the morning only.

As shown in Table 11, statistically significant reductions ($p < 0.001$) in HbA1c and FPG relative to placebo were observed with FORXIGA 5 mg and 10 mg QAM at Week 24 which were sustained long term. Overall, the PM administration of FORXIGA had a comparable safety and efficacy profile to FORXIGA administered in the AM.

Table 11 Results at Week 24 (LOCF*) in a Placebo-Controlled Study of FORXIGA Monotherapy in Patients with Type 2 Diabetes (Main Cohort AM Doses)

Efficacy Parameter	FORXIGA 5 mg N=64 [†]	FORXIGA 10 mg N=70 [†]	Placebo N=75 [†]
HbA1c (%)			
Baseline (mean)	7.83	8.01	7.79
Change from baseline (adjusted mean [‡])	-0.77	-0.89	-0.23
Difference from placebo (adjusted mean [‡]) (95% CI)	-0.54 [§] (-0.84, -0.24)	-0.66 [§] (-0.96, -0.36)	
Patients (%) achieving HbA1c <7% adjusted for baseline	44.2 [¶]	50.8 [¶]	31.6

Table 11 Results at Week 24 (LOCF*) in a Placebo-Controlled Study of FORXIGA Monotherapy in Patients with Type 2 Diabetes (Main Cohort AM Doses)

Efficacy Parameter	FORXIGA 5 mg N=64[†]	FORXIGA 10 mg N=70[†]	Placebo N=75[†]
FPG (mmol/L)			
Baseline (mean)	8.7	9.3	8.9
Change from baseline (adjusted mean [‡])	-1.3	-1.6	-0.2
Difference from placebo (adjusted mean [‡]) (95% CI)	-1.1 [§] (-1.7, -0.5)	-1.4 [§] (-2.0, -0.8)	
Body Weight (kg)			
Baseline (mean)	87.17	94.13	88.77
Change from baseline (adjusted mean [‡])	-2.83	-3.16	-2.19
Difference from placebo (adjusted mean [‡]) (95% CI)	-0.65 (-1.90, 0.61)	-0.97 (-2.20, 0.25)	

* LOCF: last observation (prior to rescue for rescued patients) carried forward.

[†] All randomized patients who took at least one dose of double-blind study medication during the short-term double-blind period.

[‡] Least squares mean adjusted for baseline value.

[§] p-value <0.001 vs. placebo.

[¶] Not evaluated for statistical significance as a result of the sequential testing procedure for the secondary endpoints

Combination Therapy

Add-On Therapy with Metformin (Study 2)

A 24-week double-blind, placebo-controlled study was conducted to evaluate FORXIGA in combination with metformin in patients with T2DM with inadequate glycemic control (HbA1c $\geq 7\%$ and $\leq 10\%$). Patients on metformin at a dose of at least 1500 mg per day were randomized after completing a 2-week single-blind placebo lead-in period. Following the lead-in period, eligible patients were randomized to dapagliflozin 2.5 mg, FORXIGA 5 mg, or 10 mg, or placebo in addition to their current dose of metformin.

As shown in Table 12, statistically significant ($p < 0.0001$) reductions in HbA1c, FPG and body weight relative to placebo were observed with FORXIGA 5 mg and 10 mg at Week 24 which were sustained long term.

Table 12 Results of a 24-Week (LOCF*) Placebo-Controlled Study of FORXIGA in Add-On Combination with Metformin

Efficacy Parameter	FORXIGA 5 mg + Metformin N=137[†]	FORXIGA 10 mg + Metformin N=135[†]	Placebo + Metformin N=137[†]
HbA1c (%)			
Baseline mean	8.17	7.92	8.11
Change from baseline (adjusted mean [‡])	-0.70	-0.84	-0.30
Difference from placebo (adjusted mean [‡]) (95% CI)	-0.41 [§] (-0.61, -0.21)	-0.54 [§] (-0.74, -0.34)	
Patients (%) achieving HbA1c <7% adjusted for baseline	37.5 [¶]	40.6 [¶]	25.9
FPG (mmol/L)			
Baseline mean	9.4	8.7	9.2
Change from baseline at week 24 (adjusted mean [‡])	-1.2	-1.3	-0.3
Difference from placebo (adjusted mean [‡]) (95% CI)	-0.9 [§] (-1.3, -0.5)	-1.0 [§] (-1.4, -0.6)	
Body Weight (kg)			
Baseline mean	84.73	86.28	87.74
Change from baseline (adjusted mean [‡])	-3.04	-2.86	-0.89
Difference from placebo (adjusted mean [‡]) (95% CI)	-2.16 [§] (-2.81, -1.50)	-1.97 [§] (-2.63, -1.31)	

* LOCF: last observation (prior to rescue for rescued patients) carried forward.

[†] All randomized patients who took at least one dose of double-blind study medication during the short-term double-blind period.

[‡] Least squares mean adjusted for baseline value.

[§] p-value <0.0001 vs. placebo + metformin.

[¶] p-value <0.05 vs. placebo + metformin.

Add-On Therapy with Metformin – Active-Controlled Study versus Glipizide (Study 3)

Patients with T2DM with inadequate glycemic control (HbA1c >6.5% and ≤10%) were randomized in a 52-week, double-blind, glipizide-controlled non-inferiority study to evaluate FORXIGA as add-on therapy to metformin. Patients on metformin at a dose of at least 1500 mg per day were randomized following a 2-week placebo lead-in period to glipizide or dapagliflozin (5 mg or 2.5 mg, respectively) and were up-titrated over 18 weeks to optimal glycemic effect (FPG <110 mg/dL, <6.1 mmol/L) or to the highest dose level (up to glipizide 20 mg and FORXIGA 10 mg) as tolerated by patients. Thereafter, doses were kept constant, except for down-titration to prevent hypoglycemia.

At the end of the titration period, 87% of patients treated with FORXIGA had been titrated to the maximum study dose (10 mg), versus 73% treated with glipizide (20 mg). As shown in Table 13, treatment with FORXIGA provided similar reductions in HbA1c from baseline compared to glipizide (with the upper bound of the 95% confidence interval around the between-group difference less than the pre-specified non-inferiority margin of 0.35%). Statistically significant ($p < 0.0001$) reductions in body weight were observed with FORXIGA compared to glipizide.

Table 13 Results at Week 52 (LOCF*) in an Active-Controlled Study comparing FORXIGA to Glipizide as Add-on to Metformin

Efficacy Parameter	FORXIGA + Metformin N=400 [†]	Glipizide + Metformin N=401 [†]
HbA1c (%)		
Baseline (mean)	7.69	7.74
Change from baseline (adjusted mean [‡])	-0.52	-0.52
Difference from Glipizide+Metformin (adjusted mean [‡]) (95% CI)	0.00 [¶] (-0.11, 0.11)	
Body Weight (kg)		
Baseline (mean)	88.44	87.60
Change from baseline (adjusted mean [‡])	-3.22	1.44
Difference from Glipizide+Metformin (adjusted mean [‡]) (95% CI)	-4.65 [§] (-5.14, -4.17)	

* LOCF: last observation carried forward.

[†] Randomized and treated patients with baseline and at least 1 post-baseline efficacy measurement.

[‡] Least squares mean adjusted for baseline value.

[§] p-value <0.0001.

[¶] non-inferior to glipizide + metformin.

Add-On Therapy with a Sulfonylurea (Study 4)

Patients with T2DM and inadequate glycemic control (HbA1c $\geq 7\%$ and $\leq 10\%$) were randomized in a 24-week, double-blind, placebo-controlled study to evaluate FORXIGA in combination with glimepiride (a sulfonylurea). Patients on at least half the maximum recommended dose of a glimepiride as monotherapy (4 mg) for at least 8 weeks lead-in were randomized to dapagliflozin 2.5 mg, FORXIGA 5 mg, or 10 mg or placebo in addition to glimepiride 4 mg per day. Down-titration of glimepiride to 2 mg or 0 mg was allowed for hypoglycemia during the treatment period; no up-titration of glimepiride was allowed.

As shown in Table 14, treatment with FORXIGA 5 mg and 10 mg in combination with glimepiride provided significant reductions in HbA1c, FPG, 2-hour PPG, and body weight relative to placebo plus glimepiride at Week 24 which were sustained long term.

Table 14 Results of 24 Week (LOCF*) Placebo-Controlled Study of FORXIGA in Combination with a Sulfonylurea (Glimepiride)

Efficacy Parameter	FORXIGA 5 mg + Glimepiride N=142[†]	FORXIGA 10 mg + Glimepiride N=151[†]	Placebo + Glimepiride N=145[†]
HbA1c (%)			
Baseline mean	8.12	8.07	8.15
Change from baseline (adjusted mean [‡])	-0.63	-0.82	-0.13
Difference from placebo + glimepiride (adjusted mean [‡]) (95% CI)	-0.49 [§] (-0.67, -0.32)	-0.68 [§] (-0.86, -0.51)	
Patients (%) achieving HbA1c <7% adjusted for baseline	30.3 [§]	31.7 [§]	13.0
FPG (mmol/L)			
Baseline mean	9.7	9.6	9.6
Change from baseline (adjusted mean [‡])	-1.2	-1.6	-0.1
Difference from placebo + glimepiride (adjusted mean [‡]) (95% CI)	-1.1 [§] (-1.5, -0.7)	-1.5 [§] (-1.9, -1.1)	
2-hour PPG[¶] (mmol/L)			
Baseline (mean)	17.9	18.3	18.0
Change from baseline (adjusted mean [‡])	-3.0	-3.4	-0.6
Difference from placebo + glimepiride (adjusted mean [‡]) (95% CI)	-2.4 [§] (-3.2, -1.5)	-2.7 [§] (-3.6, -1.9)	
Body Weight (kg)			
Baseline mean	81.00	80.56	80.94
Change from baseline (adjusted mean [‡])	-1.56	-2.26	-0.72
Difference from placebo + glimepiride (adjusted mean [‡]) (95% CI)	-0.84 ^{§§} (-1.47, -0.21)	-1.54 [§] (-2.17, -0.92)	

* LOCF: last observation (prior to rescue for rescued patients) carried forward.

[†] Randomized and treated patients with baseline and at least 1 post-baseline efficacy measurement.

[‡] Least squares mean adjusted for baseline value.

[§] p-value <0.0001 versus placebo.

^{§§} p-value 0.0091 versus placebo.

[¶] 2-hour PPG level as a response to a 75 g oral glucose tolerance test (OGTT).

Add-On Therapy with Metformin and a Sulfonylurea (Study 5)

Patients with T2DM and inadequate glycemic control (HbA1c $\geq 7\%$ and $\leq 10.5\%$) participated in a 24-week, double-blind, placebo-controlled study to evaluate FORXIGA in combination with metformin and a sulfonylurea. Patients on a stable dose of metformin (immediate- or extended-release formulations) ≥ 1500 mg/day plus maximum tolerated dose, which must be at least half maximum dose, of a sulfonylurea for at least 8 weeks prior to enrolment were

randomized after an 8-week placebo lead-in period to FORXIGA 10 mg or placebo. Dose-titration of FORXIGA or metformin was not permitted during the 24-week treatment period. Down-titration of sulfonylurea was permitted to prevent hypoglycemia during the treatment period; no up-titration of sulfonylurea was allowed.

As shown in Table 15, treatment with FORXIGA 10 mg in combination with metformin and a sulfonylurea provided significant reductions in HbA1c, FPG and body weight relative to placebo at Week 24 which were sustained long term. At Week 8, statistically significant changes from baseline in systolic blood pressure (SBP, mmHg) of -4.0, and -0.3 were observed for FORXIGA 10 mg, and placebo, respectively ($p < 0.05$).

Table 15 Results of 24-Week (LOCF*) Placebo-Controlled Study of FORXIGA in Combination with Metformin and Sulfonylurea

Efficacy Parameter	FORXIGA 10 mg + Metformin + Sulphonylurea N=108[†]	Placebo + Metformin + Sulphonylurea N=108[†]
HbA1c (%)		
Baseline mean	8.08	8.24
Change from baseline (adjusted mean ^{‡,‡‡})	-0.86	-0.17
Difference from placebo (adjusted mean ^{‡,‡‡}) (95% CI)	-0.69 [§] (-0.89, -0.49)	
Patients (%) achieving HbA1c <7% adjusted for baseline	31.8 [§]	11.1
FPG (mmol/L)		
Baseline mean	9.3	10.0
Change from baseline at Week 24 (adjusted mean [‡])	-1.9	-0.04
Difference from placebo (adjusted mean [‡]) (95% CI)	-1.86 [§] (-2.4, -1.3)	
Body Weight (kg)		
Baseline mean	88.57	90.07
Change from baseline (adjusted mean [‡])	-2.65	-0.58
Difference from placebo (adjusted mean [‡]) (95% CI)	-2.07 [§] (-2.79, -1.35)	

* LOCF: last observation (prior to rescue for rescued patients) carried forward.

† Randomized and treated patients with baseline and at least 1 post-baseline efficacy measurement.

‡ Least squares mean adjusted for baseline value based on ANCOVA model.

‡‡ Least squares mean adjusted for baseline value based on a longitudinal repeated measures model

§ p-value <0.0001 versus placebo.

Add-On Combination Therapy with Sitagliptin Alone or in Combination with Metformin (Study 6)

A total of 452 patients with T2DM who were drug naive, or who were treated at entry with metformin or sitagliptin alone or in combination, and had inadequate glycemic control (HbA1c $\geq 7.0\%$ and $\leq 10.0\%$ at randomization), participated in a 24-week, placebo-controlled study with a 24-week extension.

Patients were stratified based on background metformin use (≥ 1500 mg/day) and within each stratum were randomized to either FORXIGA 10 mg plus sitagliptin 100 mg once daily or placebo plus sitagliptin 100 mg once daily. Endpoints were tested for FORXIGA 10 mg versus placebo for the total study group (sitagliptin with and without metformin) and for each stratum (sitagliptin alone or sitagliptin with metformin).

As shown in Table 16, statistically significant ($p < 0.0001$) reductions in HbA1c, FPG and body weight relative to placebo were observed with FORXIGA 10 mg treatment for the total study group (sitagliptin with and without metformin) and for each stratum (sitagliptin alone or sitagliptin with metformin) at Week 24.

Table 16 Results of a 24-Week (LOCF*) Placebo-Controlled Study of FORXIGA in Add-On Combination with Sitagliptin with or without Metformin (Full Analysis Set and Strata without or with Metformin)

Efficacy Parameter	FORXIGA 10 mg + Sitagliptin + or -Met N=223[†]	Placebo + Sitagliptin + or -Met N=224[†]	FORXIGA 10 mg + Sitagliptin N=110[†]	Placebo + Sitagliptin N=111[†]	FORXIGA 10 mg + Sitagliptin +Met N=113[†]	Placebo + Sitagliptin +Met N=113[†]
HbA1c (%)	N=223	N=223	N=110	N=110	N=113	N=113
Baseline (mean)	7.90	7.97	7.99	8.07	7.80	7.87
Change from baseline (adjusted mean [‡])	-0.45	0.04	-0.47	0.10	-0.43	-0.02
Difference from placebo (adjusted mean [‡]) (95% CI)	-0.48 [§] (-0.62, -0.34)		-0.56 [§] (-0.79, -0.34)		-0.40 [§] (-0.58, -0.23)	
FPG (mmol/L)	N=222	N=222	N=110	N=110	N=112	N=112
Baseline (mean)	8.97	9.05	8.73	8.96	9.21	9.14
Change from baseline at Week 24 (adjusted mean [‡])	-1.34	0.21	-1.22	0.26	-1.45	0.17
Difference from placebo (adjusted mean [‡]) (95% CI)	-1.55 [§] (-1.91, -1.19)		-1.47 [§] (-2.01, -0.94)		-1.62 [§] (-2.11, -1.13)	
Body Weight (kg)	N=223	N=224	N=110	N=111	N=113	N=113
Baseline (mean)	91.02	89.23	88.01	84.20	93.95	94.17
Change from baseline (adjusted mean [‡])	-2.14	-0.26	-1.91	-0.06	-2.35	-0.47

Table 16 Results of a 24-Week (LOCF*) Placebo-Controlled Study of FORXIGA in Add-On Combination with Sitagliptin with or without Metformin (Full Analysis Set and Strata without or with Metformin)

Efficacy Parameter	FORXIGA 10 mg + Sitagliptin + or -Met N=223†	Placebo + Sitagliptin + or -Met N=224†	FORXIGA 10 mg + Sitagliptin N=110‡	Placebo + Sitagliptin N=111‡	FORXIGA 10 mg + Sitagliptin +Met N=113‡	Placebo + Sitagliptin +Met N=113‡
Difference from placebo (adjusted mean‡) (95% CI)	-1.89§ (-2.37, -1.40)		-1.85§ (-2.47, -1.23)		-1.87§ (-2.61, -1.13)	

* LOCF: last observation (prior to rescue for rescued patients) carried forward.

† Randomized and treated patients with baseline and at least 1 post-baseline efficacy measurement.

‡ Least squares mean adjusted for baseline value.

§ p-value <0.0001 versus placebo.

Add-On Therapy with Insulin (Study 7)

Patients with T2DM who had inadequate glycemic control (HbA1c $\geq 7.5\%$ and $\leq 10.5\%$) were randomized in a 24-week, double-blind, placebo-controlled study to evaluate FORXIGA as add-on therapy to insulin. Patients on a stable insulin regimen, with a mean dose of at least 30 IU of injectable insulin per day, for a period of at least 8 weeks prior and on a maximum of two oral antidiabetic medications (OADs) were randomized after completing a 2-week enrolment period to receive dapagliflozin 2.5 mg, FORXIGA 5 mg, or 10 mg, or placebo in addition to their current dose of insulin and other OADs, if applicable. Patients were stratified according to the presence or absence of background OADs. Up- or down-titration of insulin was only permitted during the treatment phase in patients who failed to meet specific glycemic goals. Subjects on metformin were to be on ≥ 1500 mg/day.

In this study, 50% (N=392) of patients were on insulin monotherapy at baseline, while 50% were on 1 or 2 OADs in addition to insulin. Of the latter, 80% (N=319) were on a background of insulin and metformin dual therapy. An inadequate number of patients on other OAD combinations were included for evaluative purposes; therefore, use with OAD combinations other than metformin alone is not indicated. In the overall patient sample 48% of patients were taking sliding scale and basal insulin, 35% were taking sliding scale insulin alone and 17% were taking basal insulin. Approximately 88% of patients completed up to Week 24. At Week 24, FORXIGA 5 mg and 10 mg doses provided significant improvement in HbA1c and mean insulin dose, and a significant reduction in body weight compared with placebo (Table 17); the effect of FORXIGA on HbA1c was similar in patients in both strata.

Table 17 Results of 24 Week (LOCF*) Placebo-Controlled Study of FORXIGA in Combination with Insulin with or without up to 2 Oral Antidiabetic Therapies^{§§}

Efficacy Parameter	FORXIGA 5 mg + Insulin N=211[†]	FORXIGA 10 mg + Insulin N=194[†]	Placebo + Insulin N=193[†]
HbA1c (%)			
Baseline mean	8.61	8.58	8.46
Change from baseline (adjusted mean [‡])	-0.82	-0.90	-0.30
Difference from placebo (adjusted mean [‡]) (95% CI)	-0.52 [§] (-0.66, -0.38)	-0.60 [§] (-0.74, -0.45)	
FPG (mmol/L)			
Baseline mean	10.3	9.6	9.4
Change from baseline (adjusted mean [‡])	-1.0	-1.2	0.2
Difference from placebo (adjusted mean [‡]) (95% CI)	-1.2 (-1.7, -0.7)	-1.4 [§] (-1.9, -0.9)	
Body Weight (kg)			
Baseline mean	93.20	94.63	94.21
Change from baseline (adjusted mean [‡])	-0.98	-1.67	0.02
Difference from placebo (adjusted mean [‡]) (95% CI)	-1.00 [§] (-1.50, -0.50)	-1.68 [§] (-2.19, -1.18)	

* LOCF: last observation (prior to rescue for rescued patients) carried forward.

[†] Randomized and treated patients with baseline and at least 1 post-baseline efficacy measurement.

[‡] Least squares mean adjusted for baseline value.

[§] p-value <0.0001 versus placebo.

^{§§} Use with oral antidiabetic combinations other than metformin alone is not indicated.

Cardiovascular Outcomes in Patients with T2DM (Study 8)

Dapagliflozin Effect on Cardiovascular Events (DECLARE-TIMI 58) was an international, multicentre, randomized, double-blind, placebo-controlled, event-driven clinical study conducted to evaluate the effect of FORXIGA compared with placebo on CV outcomes when added to current background therapy in patients with T2DM and either CV risk factors or established CV disease. The objective was to be evaluated in two steps. First, non-inferiority between FORXIGA and placebo was evaluated for the primary safety composite endpoint of CV death, myocardial infarction, and ischemic stroke, referred to as Major Adverse Cardiovascular Events (MACE). If non-inferiority for MACE was demonstrated, the study

then tested superiority of the dual primary efficacy endpoints of MACE and the composite of hospitalization for heart failure or cardiovascular death, in parallel².

All patients had T2DM and either multiple risk factors (at least two additional CV risk factors [age ≥ 55 years in men or ≥ 60 years in women and one or more of dyslipidemia, hypertension, or current tobacco use]) without having had a CV event at baseline (primary prevention) or established CV disease (secondary prevention). DECLARE-TIMI 58 was designed to ensure inclusion of a broad patient population. Concomitant antidiabetic and atherosclerotic therapies could be adjusted at the discretion of investigators according to the standard care for these diseases.

Of 17160 randomized patients, 10186 (59.4%) did not have established CV disease and 6974 (40.6%) had established CV disease. A total of 8582 patients were randomized to FORXIGA 10 mg, 8578 to placebo, and patients were followed for a mean of 4.1 years. The study was completed by 98.5% of subjects with vital status available for 99.3%, and 13181 (76.8%) subjects completed the study on study drug.

The mean age of the study population was 63.9 years, 37.4% were female, 79.6% were White, 3.5% Black or African-American, and 13.4% Asian. Approximately 46% of patients treated with FORXIGA were 65 years and older and 6.3% were 75 years and older. In total, 22.4% had had diabetes for ≤ 5 years, and the mean duration of diabetes was 11.9 years. Mean HbA1c was 8.3% and mean BMI was 32.0 kg/m². At baseline, 10.0% of patients had a history of HF. Mean eGFR was 85.2 mL/min/1.73m², 7.4% of patients had eGFR < 60 mL/min/1.73m² and 45.1% had eGFR ≥ 60 to < 90 mL/min/1.73m². At baseline, 30.3% of patients had micro- or macroalbuminuria (urine albumin to creatinine ratio ≥ 30 to ≤ 300 mg/g or > 300 mg/g, respectively). Most patients (98.1%) used one or more diabetic medications at baseline: 82.0% of the patients were being treated with metformin, 40.9% with insulin, 42.7% with a sulfonylurea, 16.8% with a DPP-4 inhibitor, and 4.4% with a GLP-1 receptor agonist. Approximately 81.3% of patients were treated with ACE inhibitors or ARB, 75.0% with statins, 61.1% with antiplatelet therapy, 55.5% with acetylsalicylic acid, 52.6% with beta-blockers, 34.9% with calcium channel blockers, 22.0% with thiazide diuretics, and 10.5% with loop diuretics.

FORXIGA demonstrated CV safety (tested against a non-inferiority margin of 1.3 versus placebo for the composite of CV death, MI or ischemic stroke [MACE]; one-sided $p < 0.001$).

FORXIGA was superior to placebo in reducing the incidence of the primary composite endpoint of hospitalization for HF or CV death, representing a 17% reduction in risk (HR 0.83 [95% CI 0.73, 0.95]; $p = 0.005$) (Figure 1). Analyses of the single components suggest that the

² Dual primary efficacy endpoints may be used when success on either endpoint could independently support a conclusion of effectiveness. The dual primary efficacy endpoints in DECLARE-TIMI 58 were tested independently and in parallel. Type I error was controlled by splitting the α between the dual primary endpoints.

difference in treatment effect was driven by hospitalization for HF (HR 0.73 [95% CI 0.61, 0.88]), with no clear difference in CV death (HR 0.98 [95% CI 0.82 to 1.17]) (Figure 2).

Figure 1 Time to First Occurrence of Hospitalization for Heart Failure or Cardiovascular Death in the DECLARE-TIMI 58 Study

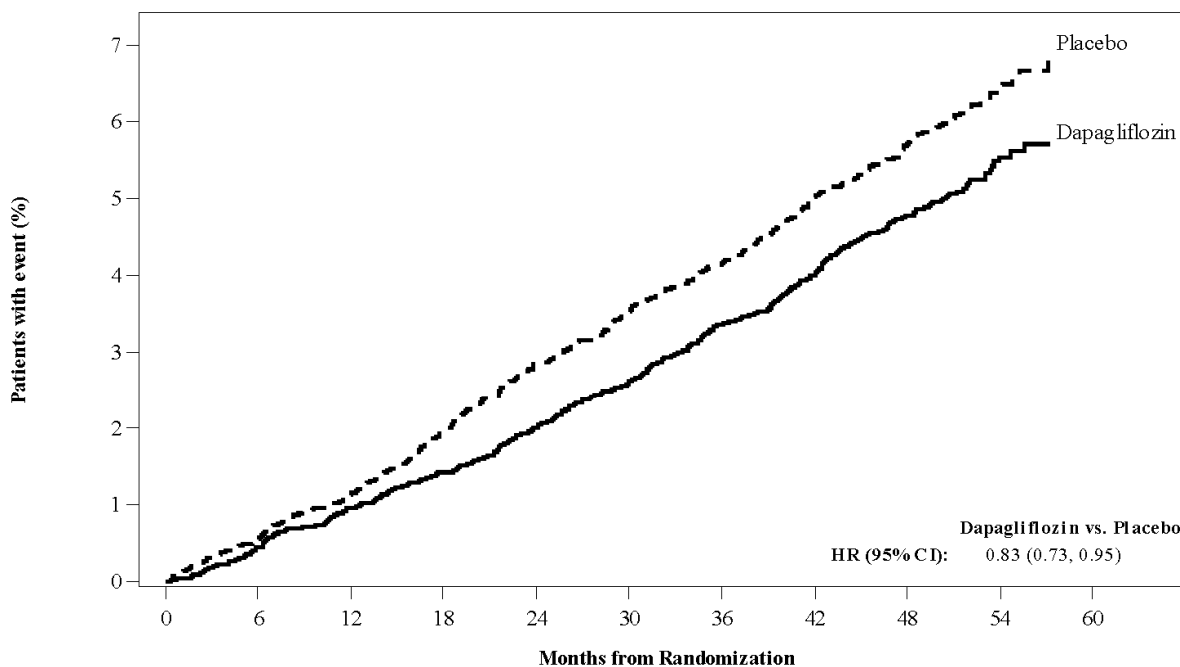

Patients at risk

Dapagliflozin:	8582	8517	8415	8322	8224	8110	7970	7497	5445	1626
Placebo:	8578	8485	8387	8259	8127	8003	7880	7367	5362	1573

Patients at risk is the number of patients at risk at the beginning of the period.
CI Confidence interval, HR Hazard ratio.

Figure 2 Time to First Occurrence of Hospitalization for Heart Failure in the DECLARE-TIMI 58 Study

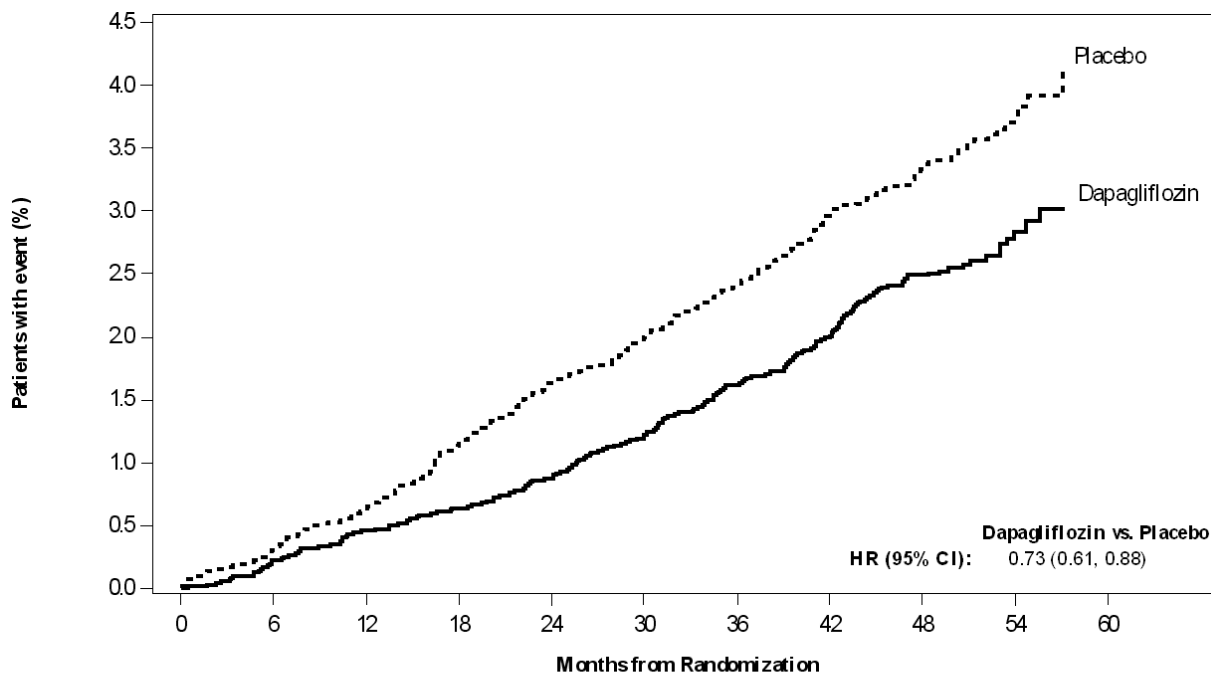

Patients at risk

Dapagliflozin:	8582	8509	8403	8315	8218	8101	7965	7489	5439	1626
Placebo:	8578	8482	8380	8256	8121	7998	7874	7360	5358	1572

Patients at risk is the number of patients at risk at the beginning of the period.
CI Confidence interval, HR Hazard ratio.

Superiority of FORXIGA over placebo was not demonstrated for MACE (HR 0.93 [95% CI 0.84, 1.03]; $p=0.172$) (Figure 3, Table 18). Analyses of the single components of MACE show that the incidence of MI was numerically lower in the dapagliflozin group compared with the placebo group (HR 0.89 [95% CI 0.77 to 1.01]), with no clear difference observed for CV death or ischemic stroke.

Figure 3 Time to First Occurrence of MACE in the DECLARE-TIMI 58 Study

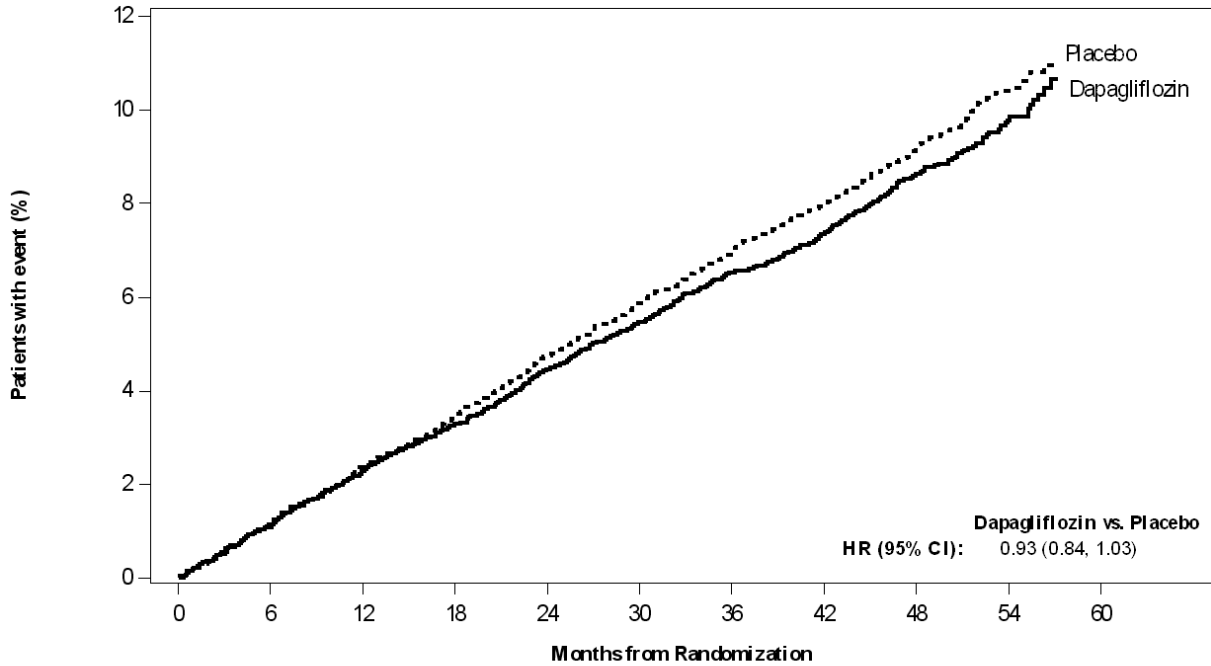

Patients at risk

Dapagliflozin:	8582	8466	8303	8166	8017	7873	7708	7237	5225	1548
Placebo:	8578	8433	8281	8129	7969	7805	7649	7137	5158	1501

Patients at risk is the number of patients at risk at the beginning of the period.
 CI Confidence interval, HR Hazard ratio.

As MACE was not statistically significant, the secondary endpoints renal composite (time to first confirmed sustained eGFR decrease, ESRD, renal or CV death) and all-cause mortality were not tested as part of the confirmatory testing.

Table 18 Treatment Effects for the Composite Endpoints* and Their Components in the DECLARE Study

Efficacy Parameter	Patients with events, n (%)		Hazard ratio (95% CI) [†]	p-value [‡]
	FORXIGA 10 mg N=8582	Placebo N=8578		
Composite of Hospitalization for HF, CV Death	417 (4.9)	496 (5.8)	0.83 (0.73, 0.95)	0.005
Hospitalization for HF [§]	212 (2.5)	286 (3.3)	0.73 (0.61, 0.88)	<0.001
CV Death [§]	245 (2.9)	249 (2.9)	0.98 (0.82, 1.17)	0.830
Composite Endpoint of CV Death, MI, Ischemic Stroke	756 (8.8)	803 (9.4)	0.93 (0.84, 1.03)	0.172
CV Death [§]	245 (2.9)	249 (2.9)	0.98 (0.82, 1.17)	0.830
Myocardial Infarction [§]	393 (4.6)	441 (5.1)	0.89 (0.77, 1.01)	0.080
Ischemic Stroke [§]	235 (2.7)	231 (2.7)	1.01 (0.84, 1.21)	0.916
Renal Composite Endpoint^{§§}	370 (4.3)	480 (5.6)	0.76 (0.67, 0.87)	
All-Cause Mortality	529 (6.2)	570 (6.6)	0.93 (0.82, 1.04)	

N=Number of patients, CI=Confidence interval, HF=Heart Failure, CV=Cardiovascular, MI=Myocardial infarction, eGFR=estimated glomerular filtration rate, ESRD=End stage renal disease

* Full analysis set

† Hazard ratio, CI, and p-values for each efficacy parameter calculated from Cox proportional hazards model (Wald test) based on time to first occurrence, stratified by baseline CV risk and hematuria with treatment as a model term.

‡ Superiority versus placebo for hospitalization for heart failure or CV death, and superiority versus placebo for MACE were tested in parallel following closed testing procedure at $\alpha = 0.0231$ (two-sided). As the composite of hospitalization for heart failure and CV was statistically significant, the full α was recycled to test MACE at $\alpha=0.0462$ (two-sided). As MACE was not statistically significant, the secondary endpoints of renal composite and all-cause mortality were not tested as part of the confirmatory testing procedure.

§ The components of the composite endpoints were exploratory variables.

§§ Confirmed sustained $\geq 40\%$ decrease in eGFR to eGFR < 60 ml/min/1.73m², ESRD (dialysis ≥ 90 days or kidney transplantation, confirmed sustained eGFR < 15 ml/min/1.73m²), renal or CV death.

Patients in DECLARE-TIMI 58 were stratified by CV risk category (CV risk factors or established CV disease). The benefit of FORXIGA over placebo in reducing the risk of

hospitalization for heart failure was observed both in patients with and without established CV disease (Figure 4) and was consistent across key subgroups including age (>65 and ≥65 years, and <75 and ≥75 years), gender, renal function (eGFR), and region. There was a trend towards an effect of dapagliflozin on MACE in patients with established CV disease at baseline and neutral results in patients with CV risk factors (Figure 4).

Figure 4 Cardiovascular Outcomes in Patients with and without Established CV Disease in the DECLARE-TIMI 58 Study

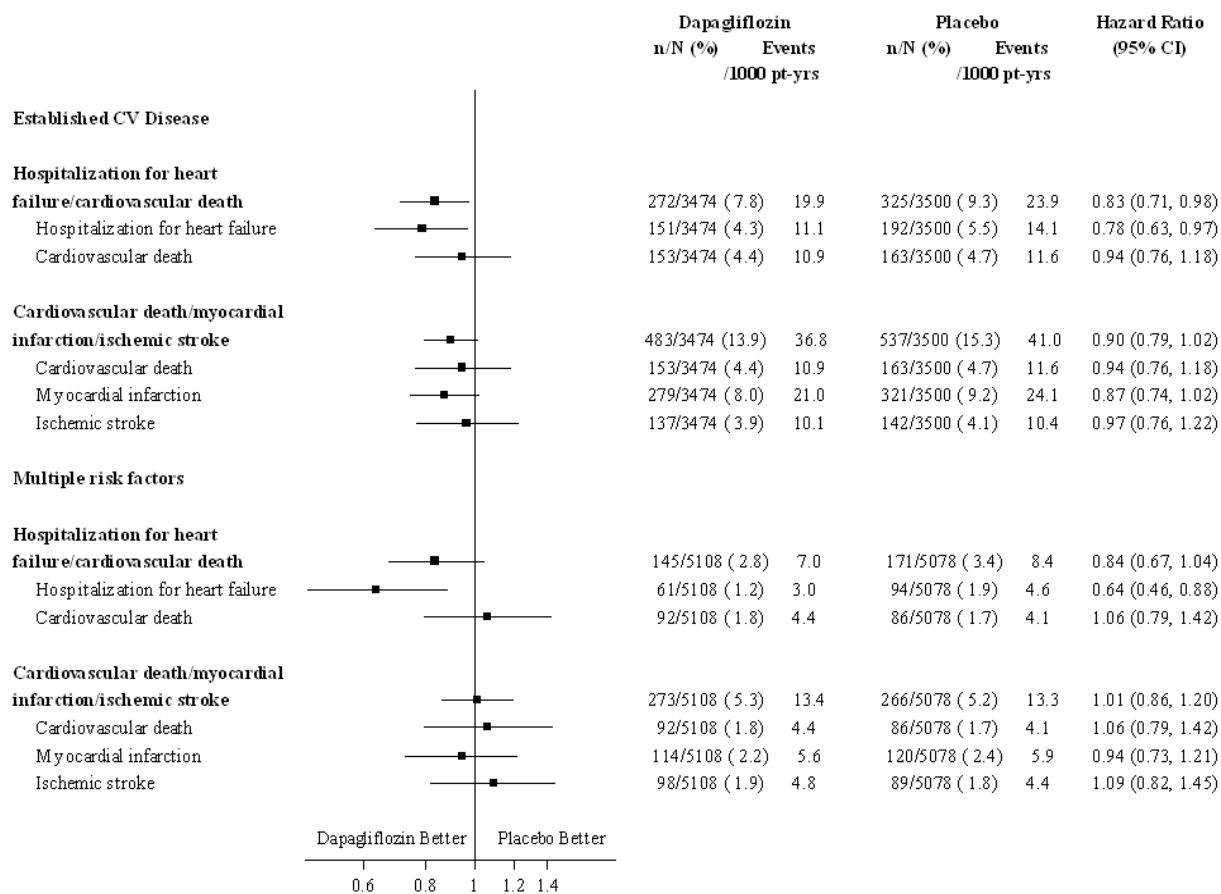

Time to first event was analysed in a Cox proportional hazards model.
CI=Confidence interval

Other Studies in Patients with T2DM Treated for Glycemic Control

Use in Patients with Type 2 Diabetes and Renal Impairment

Mild renal impairment (eGFR ≥60 to <90 mL/min/1.73m²):

Efficacy was assessed in a pooled analysis across 9 clinical studies consisting of 2226 patients with mild renal impairment. The mean change from baseline in HbA1c and the placebo-corrected mean HbA1c reduction at 24 weeks was -1.03% and -0.54%, respectively for FORXIGA 5 mg (n=545) and -1.03% and -0.54%, respectively for FORXIGA 10 mg (n=562).

The safety profile in patients with mild renal impairment is similar to that in the overall population.

The efficacy of FORXIGA was assessed in two dedicated studies of patients with moderate renal impairment and in a pooled analysis.

Moderate renal impairment CKD 3A (eGFR ≥ 45 to < 60 mL/min/1.73m²):

The efficacy of dapagliflozin was assessed in a dedicated study in diabetic patients with an eGFR ≥ 45 to < 60 mL/min/1.73m² who had inadequate glycemic control. In a randomized, double blind, placebo-controlled trial a total of 321 adult patients with T2DM and eGFR ≥ 45 to < 60 mL/min/1.73m² (moderate renal impairment subgroup CKD 3A), with inadequate glycemic control, were treated with FORXIGA 10 mg or placebo. At Week 24, FORXIGA 10 mg (n=159) resulted in statistically significant reductions in HbA1c and body weight compared with placebo (n=161) (Table 19).

Table 19 Results at Week 24 in a Placebo-Controlled Study of FORXIGA Treatment in Diabetic Patients with Moderate Renal Impairment (CKD 3A, eGFR ≥ 45 to < 60 mL/min/1.73m²)

Efficacy Parameter	FORXIGA 10 mg N=159	Placebo N=161
HbA1c (%)		
Baseline (mean)	8.35	8.03
Change from baseline (adjusted mean [*])	-0.37 [§]	-0.03
Difference from placebo (adjusted mean [*]) (95% CI)	-0.34 [§] (-0.53, -0.15)	
Body Weight (kg)		
Baseline (mean)	92.51	88.30
% Change from baseline (adjusted mean [*])	-3.42 [§]	-2.02
Difference from placebo (adjusted mean [*]) (95% CI)	-1.43 [§] (-2.15, -0.69)	

* Least squares mean adjusted for baseline value.

§ p-value < 0.001 .

Moderate renal impairment (eGFR ≥ 30 to < 60 mL/min/1.73m²):

The efficacy of FORXIGA was assessed in a study of 252 diabetic patients with eGFR ≥ 30 to < 60 mL/min/1.73m². FORXIGA treatment did not show a significant placebo corrected change in HbA1c in the overall study population at 24 weeks. In an additional analysis of the subgroup CKD 3A (eGFR ≥ 45 to < 60 mL/min/1.73m²), FORXIGA 5 mg (n=35) provided a placebo-corrected mean HbA1c change at 24 weeks of -0.37% (95% CI: -0.83, 0.10), and

FORXIGA 10 mg (n=32) provided a placebo-corrected mean HbA1c change at 24 weeks of -0.33% (95% CI: -0.80, 0.14).

Efficacy in patients with moderate renal impairment was assessed in a pooled analysis across 9 clinical studies (366 patients, 87% with eGFR \geq 45 to $<$ 60 mL/min/1.73m²); this pool did not include the two dedicated studies of diabetic patients with moderate renal impairment. The mean change from baseline in HbA1c and the placebo-corrected mean HbA1c reduction at 24 weeks was -0.71% (95% CI: -0.89, -0.53) and -0.23% (95% CI: -0.47, 0.02), respectively, for FORXIGA 5 mg (n=102) and -0.87% (95% CI: -1.07, -0.68) and -0.39% (95% CI: -0.65, -0.14), respectively, for FORXIGA 10 mg (n=85).

Use in Patients with Type 2 Diabetes and Cardiovascular Disease (CVD)

In two 24-week, placebo-controlled studies with 80-week extension periods, a total of 1876 patients with T2DM and CVD were randomized and treated with FORXIGA 10 mg (N=935) or placebo (N=941).

Patients had established CVD and inadequate glycemic control (HbA1c \geq 7.0% and \leq 10.0%), despite stable treatment with OADs and/or insulin. Ninety-six percent of patients treated with FORXIGA 10 mg had hypertension at entry, and the most common qualifying CV events were coronary heart disease (76%) or stroke (20%). Approximately 19% of patients received loop diuretics during the studies and 14% had congestive heart failure (1% had NYHA Class III). Approximately 37% of patients received metformin plus one additional OAD (sulfonylurea, thiazolidinedione, DPP4-inhibitor, or other OAD with or without insulin at entry), 38% received insulin plus at least one OAD, and 18% received insulin alone.

For both studies, at Week 24 treatment with FORXIGA 10 mg provided significant improvement in HbA1c compared with placebo (Table 20). Significant reductions in total body weight and seated systolic blood pressure were also seen in patients treated with FORXIGA 10 mg compared with placebo. For both studies, reductions in HbA1c and body weight were generally maintained at Week 52 and Week 104.

Table 20 Results at Week 24 (LOCF*) in Two Placebo-Controlled Studies Comparing FORXIGA to Placebo in Patients with Type 2 Diabetes and Cardiovascular Disease

Efficacy Parameter	Study 8 (D1690C00018)		Study 9 (D1690C00019)	
	FORXIGA 10 mg + Usual Treatment N=455 [†]	Placebo + Usual Treatment N=459 [†]	FORXIGA 10 mg + Usual Treatment N=480 [†]	Placebo + Usual Treatment N=482 [†]
HbA1c (%)				
Baseline mean	8.18	8.08	8.04	8.07
Change from baseline (adjusted mean [‡])	-0.38	0.08	-0.33	0.07

Table 20 Results at Week 24 (LOCF*) in Two Placebo-Controlled Studies Comparing FORXIGA to Placebo in Patients with Type 2 Diabetes and Cardiovascular Disease

Efficacy Parameter	Study 8 (D1690C00018)		Study 9 (D1690C00019)	
	FORXIGA 10 mg + Usual Treatment N=455 [†]	Placebo + Usual Treatment N=459 [†]	FORXIGA 10 mg + Usual Treatment N=480 [†]	Placebo + Usual Treatment N=482 [†]
Difference from placebo (adjusted mean [‡]) (95% CI)	-0.46 [§] (-0.56, -0.37)		-0.40 [§] (-0.50, -0.30)	
Body Weight (kg)				
Baseline mean	92.63	93.59	94.53	93.22
Change from baseline (adjusted percent [‡])	-2.56	-0.30	-2.53	-0.61
Difference from placebo (adjusted percent [‡]) (95% CI)	-2.27 [§] (-2.64, -1.89)		-1.93 [§] (-2.31, -1.54)	

* LOCF: last observation carried forward.

[†] Randomized and treated patients with baseline and at least 1 post-baseline efficacy measurement.

[‡] Least squares mean adjusted for baseline value.

[§] p-value <0.0001.

Blood Pressure

At Week 24 across 11 clinical studies, treatment with FORXIGA 10 mg decreased the placebo-corrected systolic blood pressure an average of -1.3 to -5.3 mmHg from baseline in all of the monotherapy and placebo-controlled add-on combination therapy studies.

Bone Mineral Density and Body Composition in Type 2 Diabetic Patients²

A 24-week study (n=182) found a greater reduction in total body weight from baseline to Week 24 in patients taking FORXIGA 10 mg plus metformin (-2.96 kg), versus placebo plus metformin (-0.88 kg), with a significant interaction for gender [greater weight loss for males (-2.76 kg) than females (-1.22 kg)]. The reduction in total body fat mass from baseline to Week 24 was -2.22 kg for FORXIGA and -0.74 kg for placebo with a reduction in percentage total body fat mass from baseline to Week 24 in the dapagliflozin group of 1%, whereas there was little change in the placebo group, as evaluated by dual energy x-ray absorptiometry (DXA).

In an extension of this study to week 102 there was no change in bone mineral density for the lumbar spine, femoral neck, or total hip seen in either treatment group (mean decrease from baseline for all anatomical regions <0.5%).

Clinical Trial in Patients with Heart Failure (Study 9)

Dapagliflozin And Prevention of Adverse outcomes in Heart Failure (DAPA-HF) was an international, multicenter, randomized, double-blind, placebo-controlled study in patients with heart failure (New York Heart Association [NYHA] functional class II-IV) with reduced ejection fraction (left ventricular ejection fraction [LVEF] $\leq 40\%$) to determine the effect of FORXIGA compared with placebo, when added to background standard of care therapy, on the incidence of CV death, hospitalization for heart failure or urgent heart failure visit.

Of 4744 patients, 2373 were randomized to FORXIGA 10 mg and 2371 to placebo and followed for a median of 18 months. The mean age of the study population was 66 years (36% of patients were between the ages of 66-75 years and 21% of patients were over 75 years), 77% were male, 70% White, 5% Black or African-American and 24% Asian.

At baseline, 67.5% patients were classified as NYHA class II, 31.6% class III and 0.9% class IV, median LVEF was 32%, 42% of the patients in each treatment group had a history of T2DM, and an additional 3% of the patients in each group were classified as having T2DM based on an HbA1c $\geq 6.5\%$ at both enrollment and randomization.

At baseline all patients were on standard of care therapy. Ninety four percent of patients were treated with ACEi, ARB, or angiotensin receptor-neprilysin inhibitor (ARNI, 11%), 96% with beta-blocker, 71% with mineralocorticoid receptor antagonist (MRA), 93% with diuretic and 26% had an implantable device.

Patients with eGFR ≥ 30 mL/min/1.73m² at enrollment were included in the study. The mean eGFR was 66 mL/min/1.73m², 41% of patients had eGFR <60mL/min/1.73m² and 15% had eGFR <45 mL/min/1.73m².

FORXIGA demonstrated a statistically significant reduction in the incidence of the primary composite endpoint of CV death, hospitalization for heart failure or urgent heart failure visit vs placebo (HR 0.74 [95% CI 0.65, 0.85]; p<0.0001). The FORXIGA and placebo event curves separated early and continued to diverge over the study period (Figure 5).

Figure 5 Time to first occurrence of the composite hospitalization of cardiovascular death, hospitalization for heart failure or urgent heart failure visit

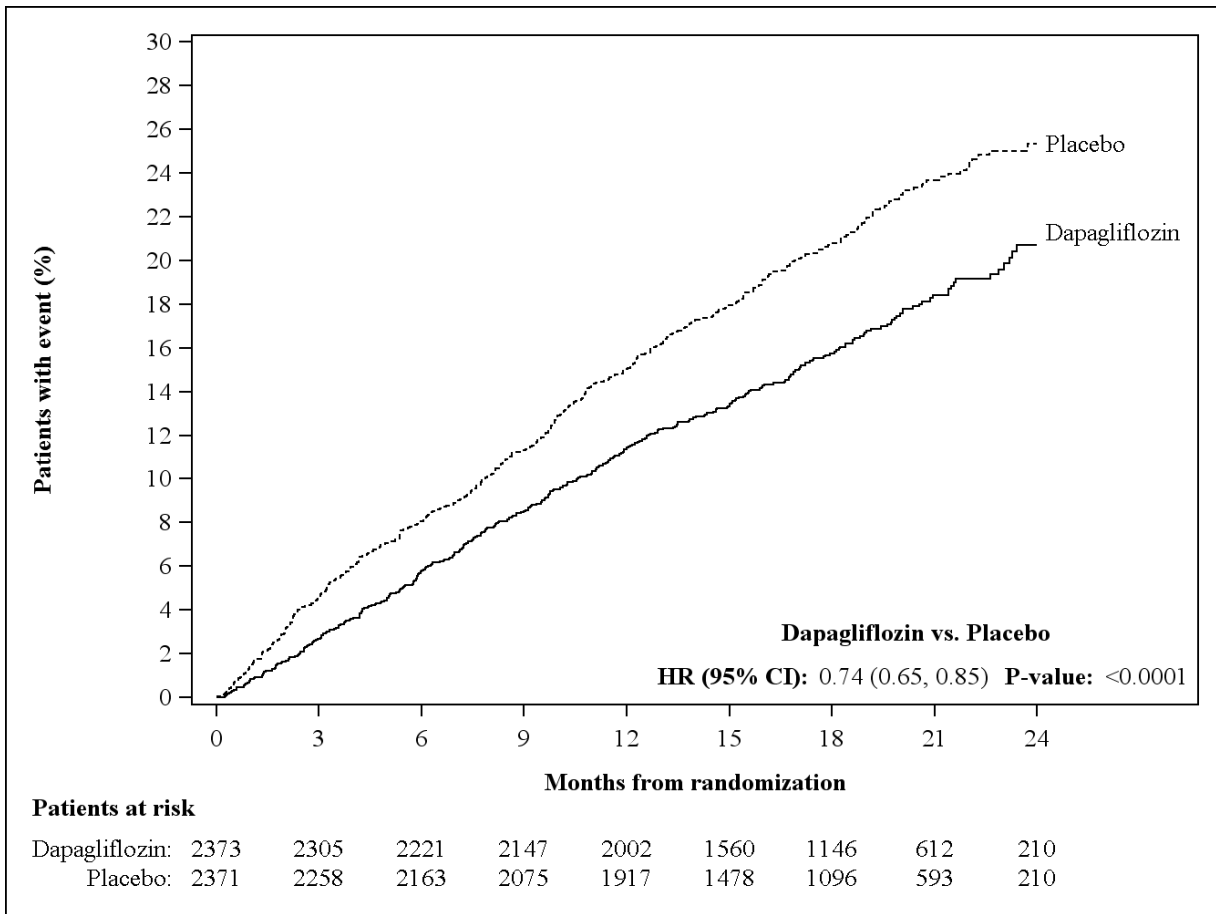

An urgent heart failure visit was defined as an urgent, unplanned, assessment by a physician, e.g. in an Emergency department, and requiring treatment for worsening heart failure (other than just an increase in oral diuretics).

Patients at risk is the number of patients at risk at the beginning of the period.

All three components of the primary composite endpoint individually contributed to the treatment effect (Figure 6). There were few urgent heart failure visits. FORXIGA also reduced the incidence of CV death or hospitalization for heart failure (HR 0.75 [95% CI 0.65, 0.85], $p < 0.0001$).

Figure 6 Treatment effects for the primary composite endpoint and its components

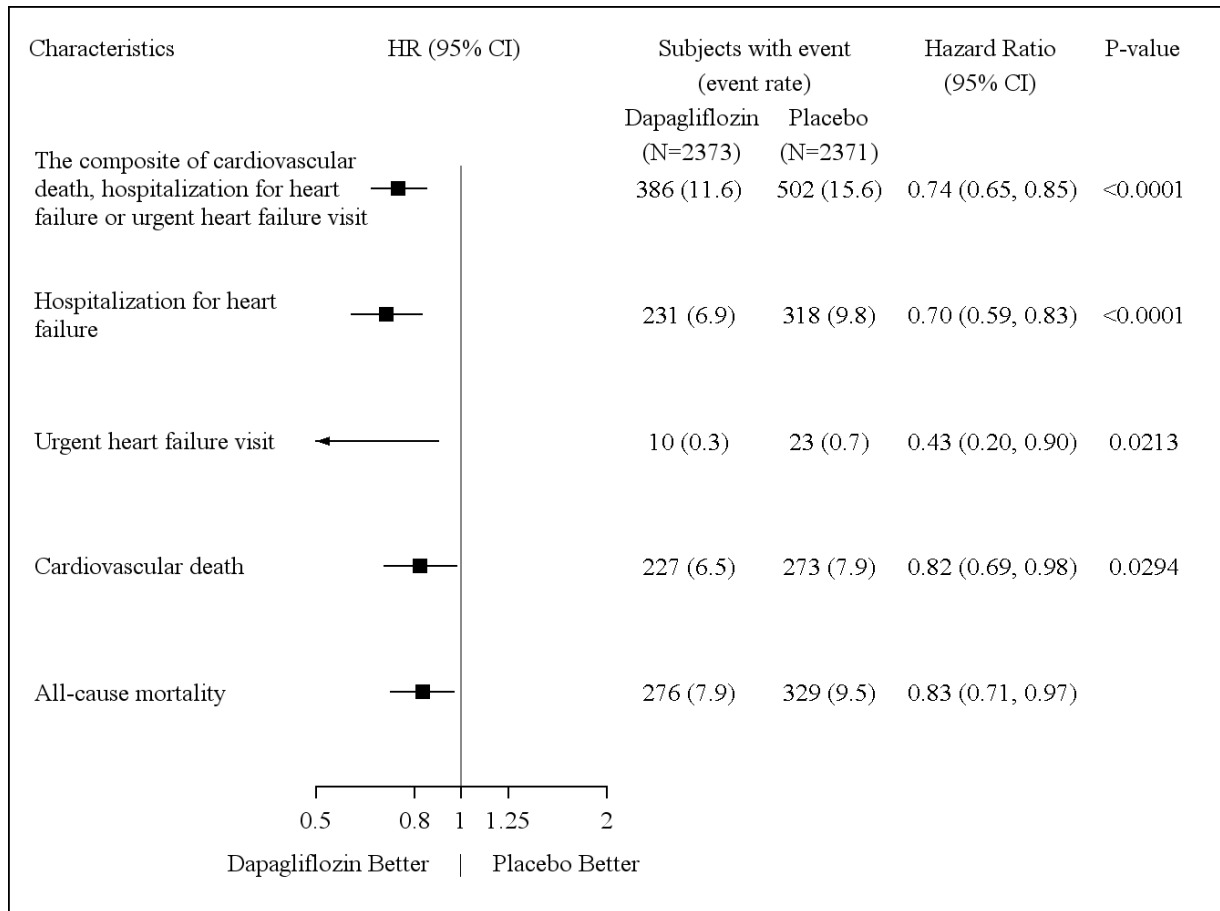

An urgent heart failure visit was defined as an urgent, unplanned, assessment by a physician, e.g. in an Emergency Department, and requiring treatment for worsening heart failure (other than just an increase in oral diuretics).

The number of first events for the single components are the actual number of first events for each component and does not add up to the number of events in the composite endpoint.

Event rates are presented as the number of subjects with event per 100 patient years of follow-up.

p-values for single components are nominal.

Superiority of dapagliflozin versus placebo for secondary endpoints was tested in a hierarchical testing sequence.

As the renal composite endpoint, preceding all-cause mortality in the sequence, was not statistically significant, all-cause mortality was not tested as part of the confirmatory testing.

FORXIGA also reduced the total number of events of hospitalizations for heart failure (first and recurrent) and CV death; there were 567 events in the FORXIGA group versus 742 events in the placebo group (Rate Ratio 0.75 [95% CI 0.65, 0.88]; p=0.0002).

The treatment benefit of FORXIGA was observed in heart failure patients both with T2DM and without diabetes (Figure 7).

Figure 7 Treatment effects in all patients, in patients with T2DM and in patients without diabetes

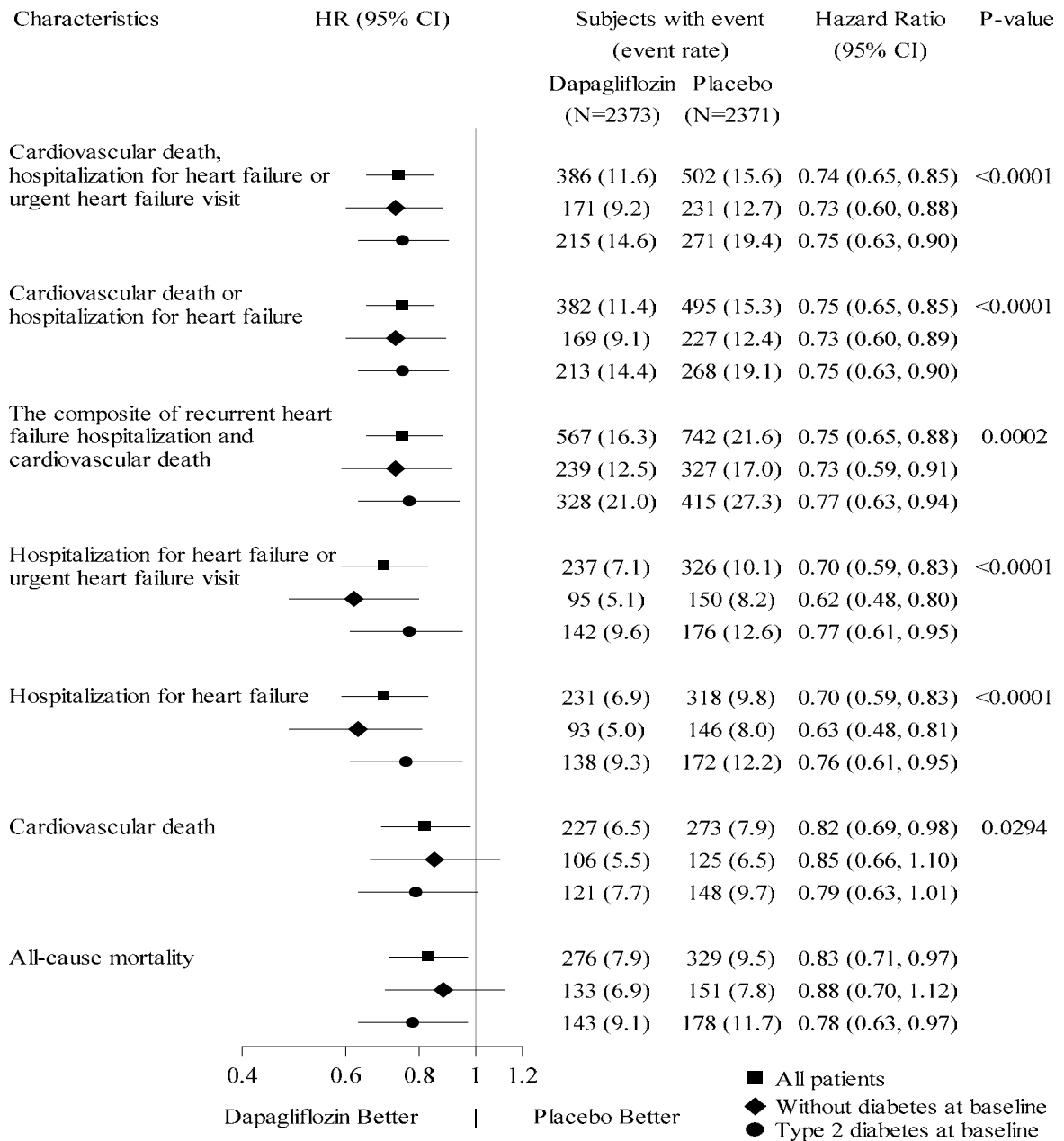

An urgent heart failure visit was defined as an urgent, unplanned, assessment by a physician, e.g. in an Emergency Department, and requiring treatment for worsening heart failure (other than just an increase in oral diuretics).

For the composite of recurrent hospitalizations for heart failure and cardiovascular death, rate ratios are presented rather than hazard ratios and the numbers of events are shown rather than subjects with event.

The number of first events for the single components are the actual number of first events for each component and does not add up to the number of events in the composite endpoint.

Event rates are presented as the number of subjects with event per 100 patient years of follow-up, or, for the composite of recurrent heart failure hospitalizations and CV death, as the average number of events per 100 patient years.

p-values for components of the primary composite endpoint are nominal.

Superiority of dapagliflozin versus placebo for secondary endpoints was tested in a hierarchical testing sequence.

As the renal composite endpoint, preceding all-cause mortality in the sequence, was not statistically significant, all-cause mortality was not tested as part of the confirmatory testing.

The treatment benefit of FORXIGA over placebo on the primary endpoint was also consistent across other key subgroups (Figure 8).

Figure 8 Treatment effects for the primary composite endpoint by sub-groups

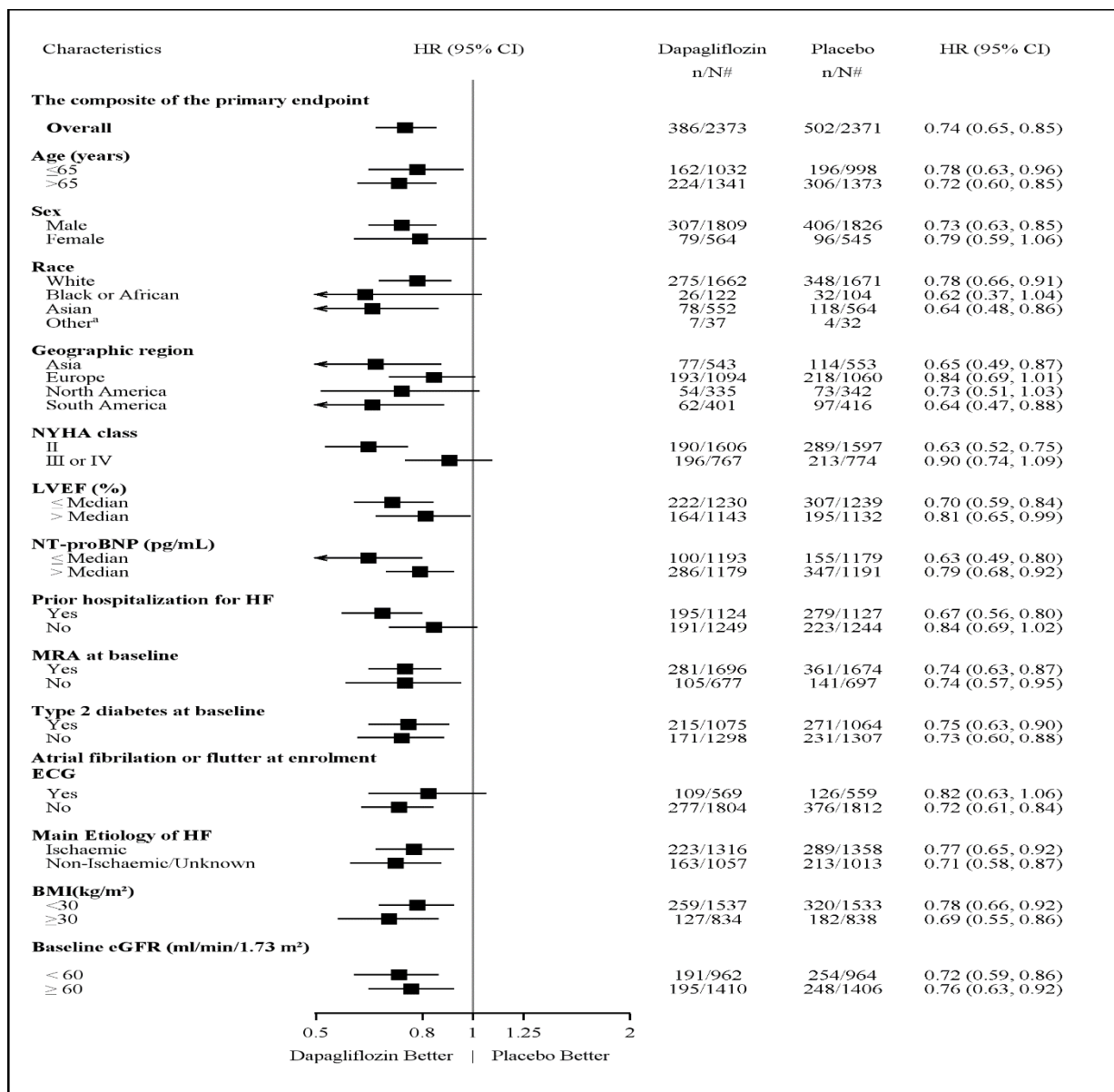

^a Hazard ratio estimates are not presented for subgroups with less than 15 events in total, both arms combined.
n/N# Number of subjects with event/number of subjects in the subgroup.
NT-proBNP = N-terminal pro b-type natriuretic peptide. HF = Heart failure

Patient Report Outcomes – heart failure symptoms

The treatment effect of FORXIGA on heart failure symptoms was assessed by the Total Symptom Score of the Kansas City Cardiomyopathy Questionnaire (KCCQ-TSS), which quantifies heart failure symptom frequency and severity, including fatigue, peripheral edema, dyspnea and orthopnea. The score ranges from 0 to 100, with higher scores representing better health status.

Treatment with FORXIGA resulted in a statistically significant and clinically meaningful benefit over placebo in heart failure symptoms, as measured by change from baseline to Month 8 in the KCCQ-TSS, (Win Ratio 1.18 [95% CI 1.11, 1.26]; $p < 0.0001$). Both symptom frequency and symptom burden contributed to the results. Benefit was seen both in improving heart failure symptoms and in preventing deterioration of heart failure symptoms.

In responder analyses, the proportion of patients with a clinically meaningful improvement on the KCCQ-TSS from baseline at 8 months, defined as 5 points or more, was higher for the dapagliflozin treatment group compared with placebo (adjusted odds ratio [OR] 1.15, 95% CI 1.08-1.23). The proportion of patients with a clinically meaningful deterioration, defined as 5 points or more, was lower for the dapagliflozin treatment group compared to placebo (OR 0.84, 95% CI 0.78-0.90). The benefits observed with dapagliflozin remained when applying more conservative cut-offs for larger clinically meaningful change, 10-point increase (OR 1.15, 95% CI 1.08-1.22), 15-point increase (OR 1.14, 95% CI 1.07-1.22) and 10-point decrease (OR 0.85, 95% CI 0.79-0.92).

DETAILED PHARMACOLOGY

The sodium-glucose cotransporter 2 (SGLT2) is selectively expressed in the kidney³ and is responsible for the majority of reabsorption of filtered glucose at that site. Dapagliflozin *in vitro* is a potent, competitive and reversible inhibitor of SGLT2. The K_i (inhibition constant) value for human SGLT2 is 0.2 nM with selectivity vs. human SGLT1 of 1200:1. Dapagliflozin is also highly selective for SGLT2 vs. the facilitative glucose transporters GLUT1, GLUT2 and GLUT4. The major human metabolite of dapagliflozin, dapagliflozin 3-O-glucuronide, is 2500-fold less active at SGLT2 and is not expected to have pharmacologic activity at clinical relevant doses. Oral administration of dapagliflozin to normal and diabetic animal models increases the excretion of glucose in the urine and increases urine volume. In diabetic animal models, dapagliflozin lowers plasma glucose and demonstrates positive effects on insulin sensitivity and preservation of beta-cell function.

TOXICOLOGY

Acute and repeat-dose toxicity

Dapagliflozin demonstrated low acute toxicity. The minimum lethal doses of dapagliflozin following single oral administration were 750 mg/kg in rats and 3000 mg/kg in mice.

Dapagliflozin was well tolerated when given orally to rats for up to 6 months at doses of ≤ 25 mg/kg/day (up to $340\times$ the human exposures (AUC) at the maximum recommended human dose (MRHD) of 10 mg/day resulting in AUC 0.465 $\mu\text{g}\cdot\text{h}/\text{mL}$, and in dogs for up to 12 months at doses of ≤ 120 mg/kg/day (up to $3300\times$ the MRHD). In rats, renal lesions (mainly cortical tubular dilatation, medullary tubular dilatation, degeneration, necrosis, mineralization, and reactive hyperplasia, and exacerbation of chronic progressive nephropathy), increased trabecular bone, and tissue mineralization (associated with increased serum calcium), were observed at high-exposure multiples ($\geq 2100\times$ the MRHD). Despite achieving exposure multiples of $\geq 3200\times$ the human exposure at the MRHD, there was no dose-limiting or target organ toxicities identified in the 12-month dog study.

Carcinogenicity

Dapagliflozin did not induce tumors in either mice or rats at any of the doses evaluated in two-year carcinogenicity studies. Oral doses in mice consisted of 5, 15, and 40 mg/kg/day in males and 2, 10, and 20 mg/kg/day in females, and oral doses in rats were 0.5, 2, and 10 mg/kg/day for both males and females. The highest doses evaluated in mice were equivalent to AUC exposure multiples of approximately $72\times$ (males) and $105\times$ (females) the human AUC at the MRHD. In rats, AUC exposures were approximately $131\times$ (males) and $186\times$ (females) the human AUC at the MRHD. In a 6-month bladder tumour initiation-promotion study in rats with dapagliflozin (7 times MRHD), the results showed that dapagliflozin does not act as promoter or progressor of bladder cancer.

Mutagenesis

Dapagliflozin was negative in the Ames mutagenicity assay, and was positive in *in vitro* clastogenicity assays but only in the presence of S9 activation and at concentrations ≥ 100 $\mu\text{g}/\text{mL}$. Dapagliflozin was negative for clastogenicity *in vivo* in a series of studies evaluating micronuclei or DNA repair in rats at exposure multiples $>2100\times$ the human exposure at the MRHD. These studies, along with the absence of tumor findings in the rat and mouse carcinogenicity studies, support that dapagliflozin does not represent a genotoxic risk to humans.

Reproduction

In a study of fertility and early embryonic development in rats, dapagliflozin had no effects on mating, fertility, or early embryonic development in treated males or females at exposure multiples up to 998× and 1708× the MHRD in males and females, respectively.

Development

In a juvenile toxicity study, when dapagliflozin was dosed directly to young rats from postnatal day (PND) 21 until PND 90 at doses of 1, 15, or 75 mg/kg/day, increased kidney weights and renal pelvic and tubular dilatations were reported at all dose levels; pup exposures at the lowest dose tested were $\geq 15\times$ the MRHD. The renal pelvic and tubular dilatations observed in juvenile animals did not fully reverse within the approximate 1-month recovery period.

In a pre- and postnatal development study, maternal rats were dosed from gestation day (GD) 6 through lactation day 21 at 1, 15, or 75 mg/kg/day, and pups were indirectly exposed *in utero* and throughout lactation. Increased incidence or severity of renal pelvic dilatation was observed in adult offspring of treated dams, at 75 mg/kg/day (maternal and pup dapagliflozin exposures were 1415× and 137×, respectively, the human values at the MHRD). Dose-related reductions in pup body weights were observed at doses ≥ 15 mg/kg/day (pup exposures were $\geq 29\times$ the human values at the MRHD). Maternal toxicity was evident only at 75 mg/kg/day, and limited to transient reductions in body weight and food consumption at dose initiation. The no-adverse-effect level (NOAEL) for developmental toxicity was 1 mg/kg/day (maternal exposure was 19× the human value at the MRHD).

In embryo-fetal development studies in rats and rabbits, dapagliflozin was administered for intervals coinciding with the major periods of organogenesis in each species. Neither maternal nor developmental toxicities were observed in rabbits up to the highest dose of 180 mg/kg/day (184× the MRHD). In rats, dapagliflozin was not teratogenic at doses up to 75 mg/kg/day (1441× the MRHD). Doses ≥ 150 mg/kg/day ($\geq 2344\times$ the MRHD) were associated with both maternal and developmental toxicities. Developmental toxicity consisted of reduced fetal body weights, increased embryo-fetal lethality, and increased incidences of fetal malformations and skeletal variations. Malformations included great vessel malformations, fused ribs and vertebral centra, and duplicated manubria and sternal centra. Variations were primarily reduced ossifications.

PART III: CONSUMER INFORMATION

Pr **FORXIGA**®

dapagliflozin tablets

(as dapagliflozin propanediol monohydrate)

Read this carefully before you start taking FORXIGA and each time you get a refill. This leaflet is a summary and will not tell you everything about this drug. Talk to your healthcare professional about your medical condition and treatment and ask if there is any new information about FORXIGA.

ABOUT THIS MEDICATION

WHAT THE MEDICATION IS USED FOR:

Type 2 diabetes

FORXIGA is used along with diet and exercise to improve blood sugar levels in adults with type 2 diabetes. FORXIGA can be used:

- alone, if you cannot take metformin,
- with metformin,
- with a sulfonylurea,
- with metformin and a sulfonylurea,
- with sitagliptin (with or without metformin),
- with insulin (with or without metformin).

FORXIGA can also be used along with diet and exercise if you have type 2 diabetes and:

- an increased cardiovascular risk. This means that you have or are at risk of developing health problems due to your heart and blood vessels. FORXIGA can be used to reduce your risk of hospitalization due to heart failure.

Heart Failure

FORXIGA can be used in adults along with other heart failure medicines when your heart is unable to pump blood as well as normal to:

- reduce your risk of cardiovascular death,
- reduce your risk of hospitalization or urgent visits for heart failure.

WHAT IT DOES:

FORXIGA removes excess sugar from the body through the urine and provides cardiovascular benefits.

WHEN IT SHOULD NOT BE USED:

Do not take FORXIGA if you:

- are allergic to dapagliflozin or any of the nonmedicinal ingredients listed below.
- have type 1 diabetes (a disease in which your body does not produce any insulin).

- have diabetic ketoacidosis (DKA, a complication of diabetes) or a history of DKA.
- have severe kidney problems or you are on dialysis.
- have severe liver disease.
- are pregnant or planning to become pregnant; it is not known if FORXIGA will harm your unborn baby. Talk to your doctor about the best way to control your blood sugar while you are pregnant.
- are breast-feeding or plan to breast-feed; it is not known if FORXIGA will pass into your breast milk. Talk to your doctor if you would like to breast-feed.

WHAT THE MEDICINAL INGREDIENT IS:

Dapagliflozin (as dapagliflozin propanediol monohydrate).

WHAT THE NONMEDICINAL INGREDIENTS ARE:

Anhydrous lactose, crospovidone, magnesium stearate, microcrystalline cellulose, silicon dioxide. In addition, the film coating contains the following inactive ingredients: polyethylene glycol, polyvinyl alcohol, talc, titanium dioxide and yellow iron oxide.

WHAT DOSAGE FORMS IT COMES IN:

Tablets 5 mg and 10 mg.

WARNINGS AND PRECAUTIONS

Serious Warnings and Precautions

- Diabetic ketoacidosis (DKA) in patients with type 2 diabetes mellitus (T2DM), is a serious and life-threatening condition that requires urgent hospitalization. DKA has been reported in patients with T2DM with normal or high blood sugar levels who are treated with FORXIGA and other sodium-glucose co-transporter 2 (SGLT2) inhibitors. Some cases of DKA have led to death.
- Seek medical attention right away and **stop taking FORXIGA immediately** if you have any of the following symptoms (even if your blood sugar levels are normal): difficulty breathing, nausea, vomiting, stomach pain, loss of appetite, confusion, feeling very thirsty, feeling unusually tired, a sweet smell to the breath, a sweet or metallic taste in the mouth, or a different odour to urine or sweat.

Do not use FORXIGA if you have:

- DKA or a history of DKA
- type 1 diabetes.

BEFORE you use FORXIGA talk to your doctor or pharmacist if you:

- have type 1 diabetes (your body does not produce any insulin). FORXIGA should not be used in patients with type 1 diabetes.
- have an increased chance of developing DKA, including if you:

- are dehydrated or suffer from excessive vomiting, diarrhea, or sweating;
- are on a very low carbohydrate diet;
- drink a lot of alcohol;
- have/have had problems with your pancreas, including pancreatitis or surgery on your pancreas;
- are hospitalized for major surgery, serious infection or serious medical illness;
- have a history of diabetic ketoacidosis (DKA).
- are older than 65 years of age
- have or have had any kidney problems
- have or have had any cases of liver disease
- have heart disease or low blood pressure
- are taking a medicine for high blood pressure or taking a water pill (used to remove excess water from the body)
- are taking medicines to lower your blood sugar such as glyburide, gliclazide or glimepiride (sulfonylureas) or insulin. Taking FORXIGA with any of these medicines can increase the risk of having low blood sugar (hypoglycemia)
- have intolerance to some milk sugars. FORXIGA tablets contain lactose
- often get urinary tract infections

FORXIGA is not recommended for use in patients under 18 years of age.

FORXIGA will cause your urine to test positive for sugar (glucose).

FORXIGA may cause changes in the amount of cholesterol or fats in your blood.

FORXIGA increases the chance of getting a yeast infection of the penis or vagina. This is more likely in people who have had yeast infections in the past.

FORXIGA may cause abnormal kidney function. Your doctor will do blood tests to monitor how well your kidneys are working while you are taking FORXIGA.

FORXIGA may cause necrotizing fasciitis of the perineum (area between and around the anus and genitals). This is a rare but serious and potentially life-threatening infection that can affect both men and women. It is also known as Fournier's gangrene and requires urgent treatment. If you experience tenderness, redness or swelling of the genitals or the area from the genitals to the rectum, especially if you also have a fever or are feeling very weak, tired, or uncomfortable, seek medical attention immediately. These may be signs of Fournier's gangrene.

Driving and using machines: FORXIGA may cause dizziness or lightheadedness. Do not drive or use machines until you know how the medicine affects you.

INTERACTIONS WITH THIS MEDICATION

Talk to your healthcare professional about all the medicines you take, including any drugs, vitamins, minerals, natural supplements or alternative medicines.

Drugs that may interact with FORXIGA include:

- medicines you take for diabetes, especially sulfonylurea medications or insulin. Low blood sugar (hypoglycemia) may occur if you already take another medication to treat diabetes. Discuss with your doctor how much of each medicine to take.

PROPER USE OF THIS MEDICATION

Follow the directions given to you by your doctor.

Take FORXIGA:

- once a day
- at any time of the day
- by mouth
- with or without food

Swallow whole. Do not cut or divide tablets.

USUAL ADULT DOSE:

Patients with Type 2 Diabetes Mellitus (T2DM)

Your dosage depends on your medical condition and response to treatment.

To control your blood sugar: the recommended adult starting dose is one 5 mg tablet a day. Your doctor may increase your dose to one 10 mg tablet, if needed.

To reduce your risk of hospitalization due to heart failure: the recommended adult dose is one 10 mg tablet a day.

Heart Failure

Recommended adult starting dose for patients with heart failure: one 10 mg tablet a day.

OVERDOSE:

In case of drug overdose, contact a health care practitioner, hospital emergency department or regional Poison Control Centre immediately, even if there are no symptoms.

MISSED DOSE: If you miss a dose of FORXIGA, take it as soon as you remember. If you do not remember until it is almost time for your next dose, skip the missed dose and go back to your regular schedule. Do not take a double dose.

SIDE EFFECTS AND WHAT TO DO ABOUT THEM

These are not all the possible side effects you may feel when taking FORXIGA. If you experience any side effects not listed here, contact your healthcare professional. Please also see Warnings and Precautions.

Side effects may include:

- sore throat
- influenza
- constipation
- diarrhea
- nausea
- back pain
- pain in the arms, legs, hands or feet
- headache
- rash

If any of these affects you severely, tell your doctor or pharmacist.

FORXIGA can cause abnormal blood test results. Your doctor will decide when to perform blood tests. They may check kidney function, blood fat levels (Low Density Lipoprotein cholesterol or LDL-C) and amount of red blood cells in your blood (hematocrit).

Diabetic Ketoacidosis (DKA) in patients with T2DM, is a serious medical condition normally seen at high blood sugar levels; however, it has also been seen at near normal blood sugar levels. Get medical help right away if you have any of the symptoms in the table below under DKA, even if your blood sugar levels are normal.

SERIOUS SIDE EFFECTS, HOW OFTEN THEY HAPPEN AND WHAT TO DO ABOUT THEM

Frequency / Symptom / effect		Talk to your healthcare professional		Stop taking drug and get immediate medical help
		Only if severe	In all cases	
Common	Urinary tract infection: pain, difficulty or increased need to urinate		X	
	Yeast infection of vagina: severe itching, burning, soreness, irritation, and a whitish or whitish-gray cottage cheese-like discharge	X		

SERIOUS SIDE EFFECTS, HOW OFTEN THEY HAPPEN AND WHAT TO DO ABOUT THEM

Frequency / Symptom / effect		Talk to your healthcare professional		Stop taking drug and get immediate medical help
		Only if severe	In all cases	
Uncommon	Yeast infection of penis: red, swollen, itchy head of penis; thick, lumpy discharge under foreskin; unpleasant odour; difficulty retracting foreskin; pain passing urine or during sex	X		
	Volume depletion (loss of needed fluids from the body; dehydration): dry or sticky mouth, headache, dizziness or urinating less often than normal		X	
	Low blood pressure: dizziness, fainting, lightheadedness; may occur when you go from lying to sitting to standing up		X	
	Low blood sugar (hypoglycemia) in patients with T2DM: shaking, sweating, rapid heartbeat, change in vision, hunger, headache and change in mood		X	

SERIOUS SIDE EFFECTS, HOW OFTEN THEY HAPPEN AND WHAT TO DO ABOUT THEM				
Frequency / Symptom / effect		Talk to your healthcare professional		Stop taking drug and get immediate medical help
		Only if severe	In all cases	
Rare	Diabetic ketoacidosis (DKA) in patients with T2DM: difficulty breathing, nausea, vomiting, stomach pain, loss of appetite, confusion, feeling very thirsty, feeling unusual tiredness, a sweet smell to the breath, a sweet or metallic taste in the mouth, or a different odour to urine or sweat			X
	Kidney problems: any change in the amount, frequency or colour (pale or dark) of urine		X	
	Fournier's gangrene (a serious infection affecting soft tissue around the groin): pain or tenderness, redness of the skin, or swelling in the genital or perineal area, with or without fever or feeling very weak, tired, or uncomfortable			X

SERIOUS SIDE EFFECTS, HOW OFTEN THEY HAPPEN AND WHAT TO DO ABOUT THEM				
Frequency / Symptom / effect		Talk to your healthcare professional		Stop taking drug and get immediate medical help
		Only if severe	In all cases	
Very rare	Acute kidney infection: painful, urgent or frequent urination, lower back (flank) pain, fever or chills, cloudy or foul smelling urine, blood in your urine			X
	Severe infection that spreads from urinary tract throughout body (sepsis): fever or low body temperature, chills, rapid breathing, rapid heartbeat, pain with urination, difficulty urinating, frequent urination			X
	Inflammation of the pancreas (pancreatitis): severe stomach pain that lasts and gets worse when you lie down, nausea, vomiting		X	

This is not a complete list of side effects. For any unexpected effects while taking FORXIGA, contact your doctor or pharmacist.

Reporting Side Effects

You can report any suspected side effects associated with the use of health products to Health Canada by:

- Visiting the Web page on Adverse Reaction Reporting (<https://www.canada.ca/en/health-canada/services/drugs-health-products/medeffect-canada/adverse-reaction-reporting.html>) for information on how to report online, by mail or by fax; or
- Calling toll-free at 1-866-234-2345

NOTE: Contact your health professional if you need information about how to manage your side effects. The Canada Vigilance Program does not provide medical advice.

HOW TO STORE IT

Store at room temperature (15 to 30 °C).

Keep FORXIGA out of the reach and sight of children.

MORE INFORMATION

NOTE: This CONSUMER INFORMATION leaflet provides you with the most current information at the time of printing.

The most current information, the Consumer Information Leaflet plus the full Product Monograph, prepared for health professionals can be found at: <http://www.astrazeneca.ca> or by contacting the sponsor, AstraZeneca Canada Inc. at: Customer Inquiries 1-800-668-6000, Renseignements 1-800-461-3787.

This leaflet was prepared by:
AstraZeneca Canada Inc. Mississauga, Ontario L4Y 1M4

FORXIGA® and the AstraZeneca logo are registered trademarks of AstraZeneca AB, used under license by AstraZeneca Canada Inc.

© AstraZeneca 2014 – 2020

Last revised: June 29, 2020

PRODUCT MONOGRAPH
INCLUDING PATIENT MEDICATION INFORMATION

 **GENVOYA[®]**

**(elvitegravir/cobicistat/emtricitabine/tenofovir alafenamide)
tablets**

150 mg elvitegravir
150 mg cobicistat
200 mg emtricitabine
10 mg tenofovir alafenamide*

*as 11.2 mg tenofovir alafenamide hemifumarate

Antiretroviral Agent

Gilead Sciences Canada, Inc.
Mississauga, ON L5N 2W3

www.gilead.ca

Date of Initial Approval:
November 27, 2015

Date of Revision:
May 8, 2020

Submission Control No: 236379

RECENT MAJOR LABEL CHANGES

Indications (1)	05/2018
Indications, Pediatrics (1.1)	05/2018
Contraindications (2)	04/2018
Serious Warning and Precautions Box (3), Lactic Acidosis and Severe Hepatomegaly with Steatosis [Removed]	05/2018
Dosage and Administration, Testing Prior to Initiation and During Treatment with GENVOYA (4.1)	08/2018
Dosage and Administration, Recommended Dose and Dose Adjustment (4.3)	08/2018
Warnings and Precautions, General	05/2020
Warnings and Precautions, Endocrine and Metabolism (7)	05/2018
Warnings and Precautions, Hepatic/Biliary/Pancreatic (7)	05/2018
Warnings and Precautions, Immune (7)	05/2019
Warnings and Precautions, Musculoskeletal (7)	05/2018

TABLE OF CONTENTS

RECENT MAJOR LABEL CHANGES.....	2
TABLE OF CONTENTS	2
PART I: HEALTH PROFESSIONAL INFORMATION.....	4
1 INDICATIONS	4
1.1 Pediatrics (weighing \geq 25 kg)	4
1.2 Geriatrics (\geq 65 years of age).....	4
2 CONTRAINDICATIONS	4
3 SERIOUS WARNINGS AND PRECAUTIONS BOX.....	7
4 DOSAGE AND ADMINISTRATION	7
4.1 Testing Prior to Initiation and During Treatment with GENVOYA	7
4.2 Dosing Considerations	7
4.3 Recommended Dose and Dose Adjustment	7
4.4 Missed Dose.....	8
5 OVERDOSAGE.....	8
6 DOSAGE FORMS, STRENGTHS, COMPOSITION AND PACKAGING.....	9
7 WARNINGS AND PRECAUTIONS.....	10
7.1 Special Populations	13
7.1.1 Patients Coinfected with HIV and HBV	13
7.1.2 Pregnant Women	13
7.1.3 Nursing Women.....	14
8 ADVERSE REACTIONS	14
8.1 Adverse Drug Reaction Overview	14
8.2 Clinical Trial Adverse Drug Reactions.....	15
8.3 Less Common Clinical Trial Adverse Drug Reactions (< 1%).....	16
8.4 Laboratory Abnormalities.....	16
8.5 Clinical Trials in Virologically Suppressed Patients.....	20
8.6 Clinical Trials in Adult Patients with Renal Impairment	20
8.7 Clinical Trials in Pediatric Patients (6 to < 18 years of age).....	20

8.8	Post-Market Adverse Drug Reactions	21
9	DRUG INTERACTIONS	22
9.1	Drug-Drug Interactions	22
9.2	Drug-Food Interactions	40
9.3	Drug-Herb Interactions	40
9.4	Drug-Laboratory Interactions	40
10	ACTION AND CLINICAL PHARMACOLOGY	40
10.1	Mechanism of Action	40
10.2	Pharmacodynamics	42
10.3	Pharmacokinetics	42
11	STORAGE AND STABILITY	49
12	SPECIAL HANDLING INSTRUCTIONS	49
PART II: SCIENTIFIC INFORMATION		50
13	PHARMACEUTICAL INFORMATION	50
14	CLINICAL TRIALS	53
14.1	Study Demographics and Trial Design	53
14.2	Study results	56
15	MICROBIOLOGY	75
16	NON-CLINICAL TOXICOLOGY	79
PATIENT MEDICATION INFORMATION		83

GENVOYA®

(elvitegravir/cobicistat/emtricitabine/tenofovir alafenamide*) tablets

*as tenofovir alafenamide hemifumarate

PART I: HEALTH PROFESSIONAL INFORMATION

1 INDICATIONS

GENVOYA (150 mg elvitegravir/150 mg cobicistat/200 mg emtricitabine/10 mg tenofovir alafenamide) is indicated as a complete regimen for the treatment of human immunodeficiency virus type 1 (HIV-1) infection in adults and pediatric patients weighing ≥ 25 kg and with no known mutations associated with resistance to the individual components of GENVOYA.

1.1 Pediatrics (weighing ≥ 25 kg)

The safety and efficacy in children weighing ≥ 25 kg are based on data from an open-label clinical study (see **ADVERSE REACTIONS** and **CLINICAL TRIALS**).

Safety and efficacy of GENVOYA in children weighing less than 25 kg have not been established.

1.2 Geriatrics (≥ 65 years of age)

No differences in safety or efficacy have been observed between elderly patients and adult patients < 65 years of age (see **ACTION AND CLINICAL PHARMACOLOGY**).

2 CONTRAINDICATIONS

GENVOYA is contraindicated in patients with known hypersensitivity to any of the components of the product. For a complete listing, see the **DOSAGE FORMS, STRENGTHS, COMPOSITION AND PACKAGING** section of the Product Monograph.

Coadministration with the following drugs listed in Table 1 is contraindicated due to the potential for serious and/or life-threatening events or loss of virologic response and possible resistance to GENVOYA. **See also DRUG INTERACTIONS, Drug-Drug Interactions.**

Table 1. Drugs That Are Contraindicated with GENVOYA

Drug Class	Drugs within class that are contraindicated with GENVOYA	Clinical Comment
Alpha 1-adrenoreceptor antagonists	alfuzosin	Potential for increased alfuzosin concentrations, which can result in hypotension.
Anticonvulsants	carbamazepine, phenobarbital, phenytoin	Carbamazepine, phenobarbital, and phenytoin are potent inducers of CYP450 metabolism and may cause significant decrease in the plasma concentration of elvitegravir, cobicistat and tenofovir alafenamide. This may result in loss of therapeutic effect to GENVOYA.
Antihistamines	astemizole*, terfenadine*	Potential for serious and/or life-threatening reactions such as cardiac arrhythmias.
Antimycobacterials	rifampin	Rifampin is a potent inducer of CYP450 metabolism and may cause significant decrease in the plasma concentration of elvitegravir, cobicistat and tenofovir alafenamide. This may result in loss of therapeutic effect to GENVOYA.
Benzodiazepines	orally administered midazolam*, triazolam	Triazolam and orally administered midazolam are extensively metabolized by CYP3A4. Coadministration of triazolam or orally administered midazolam with GENVOYA may cause large increases in the concentration of these benzodiazepines. The potential exists for serious and/or life-threatening events such as prolonged or increased sedation or respiratory depression.
Beta 2-adrenoceptor agonist	salmeterol	Coadministration of salmeterol with GENVOYA may result in increased risk of cardiovascular adverse events associated with salmeterol, including QT prolongation, palpitations, and sinus tachycardia.
Direct oral anticoagulants	apixaban, rivaroxaban	Apixaban and rivaroxaban are primarily metabolized by CYP3A4 and transported by P-gp. Coadministration with GENVOYA may result in increased plasma concentrations of apixaban or rivaroxaban, which may lead to an increased bleeding risk.
Ergot derivatives	dihydroergotamine, ergonovine, ergotamine, methylergonovine*	Potential for serious and/or life-threatening events such as acute ergot toxicity characterized by peripheral vasospasm and ischemia of the extremities and other tissues.
GI motility agents	cisapride*	Potential for serious and/or life-threatening events such as cardiac arrhythmias.

GENVOYA (elvitegravir/cobicistat/emtricitabine/tenofovir alafenamide*) tablets

*as tenofovir alafenamide hemifumarate

Product Monograph

Drug Class	Drugs within class that are contraindicated with GENVOYA	Clinical Comment
Herbal products	St. John's Wort (<i>Hypericum perforatum</i>)	Coadministration of products containing St. John's Wort and GENVOYA may result in reduced plasma concentrations of elvitegravir, cobicistat and tenofovir alafenamide. This may result in loss of therapeutic effect and development of resistance.
HMG-CoA reductase inhibitors	lovastatin, simvastatin	Potential for serious reactions such as myopathy, including rhabdomyolysis.
Neuroleptics	lurasidone pimozide	Potential for serious and/or life-threatening reactions. Potential for serious and/or life-threatening events such as cardiac arrhythmias.
PDE-5 inhibitors	sildenafil†	A safe and effective dose in combination with GENVOYA has not been established for sildenafil (REVATIO®) when used for the treatment of pulmonary arterial hypertension. There is increased potential for sildenafil-associated adverse events (which include visual disturbances, hypotension, priapism, and syncope).

*Not marketed in Canada.

†For the treatment of pulmonary arterial hypertension

3 SERIOUS WARNINGS AND PRECAUTIONS BOX

Serious Warnings and Precautions

- **Post-treatment Exacerbation of Hepatitis B**

GENVOYA is not approved for the treatment of chronic hepatitis B virus (HBV) infection and the safety and efficacy of GENVOYA have not been established in patients coinfecting with HIV-1 and HBV. Discontinuation of GENVOYA therapy in patients coinfecting with HIV-1 and HBV may be associated with severe acute exacerbations of hepatitis due to the emtricitabine or tenofovir alafenamide components of GENVOYA. Hepatic function should be monitored closely with both clinical and laboratory follow-up for at least several months in patients who are coinfecting with HIV-1 and HBV and discontinue GENVOYA. If appropriate, initiation of anti-hepatitis B therapy may be warranted (see **WARNINGS AND PRECAUTIONS, Special Populations**).

4 DOSAGE AND ADMINISTRATION

4.1 Testing Prior to Initiation and During Treatment with GENVOYA

Prior to or when initiating GENVOYA, test patients for hepatitis B virus infection.

Prior to or when initiating GENVOYA, and during treatment with GENVOYA, assess serum creatinine, estimated creatinine clearance (CrCl), urine glucose and urine protein in all patients on a clinically appropriate schedule. In patients with chronic kidney disease, also assess serum phosphorus (see **WARNINGS AND PRECAUTIONS, Renal**).

4.2 Dosing Considerations

GENVOYA is one tablet (containing 150 mg of elvitegravir, 150 mg of cobicistat, 200 mg of emtricitabine and 10 mg of tenofovir alafenamide) taken orally once daily with food.

4.3 Recommended Dose and Dose Adjustment

Adults and Pediatric Patients weighing \geq 25 kg

The recommended dose of GENVOYA is one tablet daily.

Pediatrics (weighing < 25 kg)

GENVOYA is not indicated for use in pediatric patients weighing < 25 kg.

Geriatrics (≥ 65 years of age)

No dose adjustment is required for elderly patients. No differences in safety or efficacy have been observed between elderly patients and adult patients < 65 years of age.

Renal Impairment

No dose adjustment of GENVOYA is required in adult patients with estimated CrCl ≥ 30 mL/minute or in adult patients with end stage renal disease (estimated CrCl < 15 mL/minute) on chronic hemodialysis. On days of hemodialysis, administer GENVOYA after completion of hemodialysis treatment.

GENVOYA is not recommended in patients with estimated CrCl ≥ 15 and < 30 mL/minute, or < 15 mL/minute who are not on chronic hemodialysis, as the safety of GENVOYA has not been established in these populations.

No data are available to make dose recommendations in pediatric patients with renal impairment.

Hepatic Impairment

No dose adjustment of GENVOYA is required in patients with mild (Child-Pugh Class A) or moderate (Child-Pugh Class B) hepatic impairment. GENVOYA has not been studied in patients with severe hepatic impairment (Child-Pugh Class C); therefore, GENVOYA is not recommended for use in patients with severe hepatic impairment (see **ACTION AND CLINICAL PHARMACOLOGY**).

4.4 Missed Dose

If a patient misses a dose of GENVOYA within 18 hours of the time it is usually taken, the patient should take GENVOYA with food as soon as possible, and then take the next dose of GENVOYA at the regularly scheduled time.

If a patient misses a dose of GENVOYA by more than 18 hours, the patient should not take the missed dose, but resume the usual dosing schedule.

5 OVERDOSAGE

For management of a suspected drug overdose, contact your regional Poison Control Centre.

If overdose occurs the patient must be monitored for evidence of toxicity. Treatment of overdose with GENVOYA consists of general supportive measures including monitoring of vital signs as well as observation of the clinical status of the patient.

Elvitegravir

Limited clinical experience is available at doses higher than the therapeutic dose of elvitegravir in GENVOYA. In one study, boosted elvitegravir equivalent to 2 times the therapeutic dose of 150 mg once daily for 10 days was administered to 42 healthy subjects. No severe adverse reactions were reported. The effects of higher doses are not known. As elvitegravir is highly bound to plasma proteins, it is unlikely that it will be significantly removed by hemodialysis or peritoneal dialysis.

Cobicistat

Limited clinical experience is available at doses higher than the therapeutic dose of cobicistat in GENVOYA. In two studies, a single dose of cobicistat 400 mg (2.7 times the dose in GENVOYA) was administered to a total of 60 healthy subjects. No severe adverse reactions were reported. The effects of higher doses are not known. As cobicistat is highly bound to plasma proteins, it is unlikely that it will be significantly removed by hemodialysis or peritoneal dialysis.

Emtricitabine

Limited clinical experience is available at doses higher than the therapeutic dose of emtricitabine in GENVOYA. In one clinical pharmacology study, single doses of emtricitabine 1200 mg (6 times the dose in GENVOYA) were administered to 11 subjects. No severe adverse reactions were reported. The effects of higher doses are not known.

Emtricitabine can be removed by hemodialysis, which removes approximately 30% of the emtricitabine dose over a 3 hour dialysis period starting within 1.5 hours of emtricitabine dosing.

It is not known whether emtricitabine can be removed by peritoneal dialysis.

Tenofovir alafenamide

Limited clinical experience is available at doses higher than the therapeutic dose of tenofovir alafenamide in GENVOYA. A single suprathereapeutic dose of 125 mg tenofovir alafenamide was administered to 48 healthy subjects. No serious adverse reactions were reported. The effects of higher doses are unknown. Tenofovir is efficiently removed by hemodialysis with an extraction coefficient of approximately 54%.

6 DOSAGE FORMS, STRENGTHS, COMPOSITION AND PACKAGING

GENVOYA is available as tablets. Each tablet contains 150 mg of elvitegravir, 150 mg of cobicistat, 200 mg of emtricitabine, and 10 mg of tenofovir alafenamide (as 11.2 mg of tenofovir alafenamide hemifumarate).

The tablets also include the following inactive ingredients: croscarmellose sodium, hydroxypropyl cellulose, lactose monohydrate, magnesium stearate, microcrystalline cellulose, silicon dioxide, and sodium lauryl sulfate. The tablets are coated with a coating material containing polyvinyl alcohol, titanium dioxide, polyethylene glycol, talc, indigo carmine aluminum lake, and iron oxide yellow.

GENVOYA is available as green capsule-shaped, film-coated tablets, debossed with 'GSI' on one side of the tablet and '510' on the other side of the tablet. Each bottle contains 30 tablets and a silica gel desiccant and closed with a child-resistant closure.

7 WARNINGS AND PRECAUTIONS

General

GENVOYA is a fixed dose combination of elvitegravir, cobicistat, emtricitabine and tenofovir alafenamide.

It should not be coadministered with any other antiretroviral products including products which contain elvitegravir, cobicistat, emtricitabine, or tenofovir alafenamide (ATRIPLA[®], BIKTARVY[®], COMPLERA[®], DESCOVY[®], EMTRIVA[®], ODEFSEY[®], Prezcoix**[®], STRIBILD[®], Symtuza[™], TRUVADA[®], TYBOST[®], VEMLIDY[®]); or with products containing lamivudine or tenofovir disoproxil fumarate (3TC[®], ATRIPLA, Combivir[®], COMPLERA, Kivexa[®], STRIBILD, Triumeq[®], Trizivir[®], TRUVADA, VIREAD[®]). GENVOYA should not be administered concurrently with ritonavir or ritonavir-containing products (Holkira[™] Pak, Kaletra[®], Norvir[®]) or regimens due to similar effects of cobicistat and ritonavir on cytochrome P450 (CYP3A). GENVOYA should not be administered with adefovir dipivoxil (HEPSERA[®]).**

Risk of Adverse Reactions or Loss of Virologic Response Due to Drug Interactions with CYP3A Substrates or Inducers:

Coadministration of GENVOYA with drugs that are primarily metabolized by CYP3A may result in increased plasma concentrations of such drugs, which may lead to serious and/or life-threatening events. Coadministration of GENVOYA with drugs that have active metabolite(s) formed by CYP3A may result in reduced plasma concentrations of these active metabolite(s), potentially leading to loss of therapeutic effect of the coadministered drug. Drugs that induce CYP3A activity may decrease plasma concentrations of cobicistat and elvitegravir, which may lead to loss of therapeutic effect of GENVOYA and development of resistance (see **CONTRAINDICATIONS** and **DRUG INTERACTIONS**).

Endocrine and Metabolism

Serum Lipids and Blood Glucose

Serum lipid and blood glucose levels may increase during antiretroviral therapy (ART). Disease control and life style changes may also be contributing factors. Consideration should be given to the measurement of serum lipids and blood glucose. Lipid disorders and blood glucose elevations should be managed as clinically appropriate.

Hepatic/Biliary/Pancreatic

Hepatic Impairment

No pharmacokinetic or safety data are available regarding the use of GENVOYA in patients with severe hepatic impairment (Child-Pugh Class C). Therefore, GENVOYA is not recommended for use in patients with severe hepatic impairment.

The safety and efficacy of GENVOYA have not been established in patients with underlying liver disorders. Patients with chronic hepatitis B or C who are treated with ART are at increased risk for severe and potentially fatal hepatic adverse events (see **WARNINGS AND PRECAUTIONS, Special Populations**).

Pancreatitis

Caution should be exercised in the use of GENVOYA in patients with a history of pancreatitis or risk factors for the development of pancreatitis. Pancreatitis has occurred during the use of nucleoside analogues. Therapy should be suspended in patients with suspected pancreatitis.

Lactic Acidosis/Severe Hepatomegaly with Steatosis

Lactic acidosis and severe hepatomegaly with steatosis, including fatal cases, have been reported with the use of nucleoside analogs, including emtricitabine, a component of GENVOYA, and tenofovir disoproxil fumarate, another prodrug of tenofovir, alone or in combination with other antiretrovirals. Treatment with GENVOYA should be suspended in any patient who develops clinical or laboratory findings suggestive of lactic acidosis or pronounced hepatotoxicity (which may include hepatomegaly and steatosis even in the absence of marked transaminase elevations).

Immune

Immune Reconstitution Inflammatory Syndrome

Immune reconstitution inflammatory syndrome has been reported in patients treated with combination ART, including emtricitabine, a component of GENVOYA. During the initial phase of combination antiretroviral treatment, patients whose immune system

responds may develop an inflammatory response to indolent or residual opportunistic infections [such as *Mycobacterium avium* infection, cytomegalovirus, *Pneumocystis jirovecii* pneumonia (PCP), or tuberculosis], which may necessitate further evaluation and treatment.

Autoimmune disorders (such as Graves' disease, polymyositis, Guillain-Barré syndrome, and autoimmune hepatitis) have also been reported to occur in the setting of immune reconstitution inflammatory syndrome, however, the time to onset is more variable, and can occur many months after initiation of treatment.

Musculoskeletal

Bone Effects

Tenofovir alafenamide and tenofovir have been shown to be associated with decreases in bone mineral density (BMD) in animal toxicology studies and in human clinical trials. In a pooled analysis of two Phase 3 clinical studies in HIV-1 infected ART treatment-naïve adults, the percentage of patients treated with GENVOYA who had more than a 3% decrease from baseline in hip and spine BMD at Week 48 was 17% and 27%, respectively, at Week 96 was 23% and 26%, respectively, and at Week 144 was 28% and 30%, respectively (see **CLINICAL TRIALS**).

The effects of tenofovir alafenamide-associated changes in BMD on long-term bone health and future fracture risk are unknown.

Renal

Although cobicistat may cause modest increases in serum creatinine and modest declines in estimated CrCl without affecting renal glomerular function (see **ADVERSE REACTIONS, Laboratory Abnormalities**) patients who experience a confirmed increase in serum creatinine of greater than 0.4 mg per dL (35.36 µmol/L) from baseline should be closely monitored for renal safety, including measuring serum phosphorus, urine glucose and urine protein (see **DOSAGE AND ADMINISTRATION, Testing Prior to Initiation and During Treatment with GENVOYA**).

Renal impairment, including cases of acute renal failure and Fanconi syndrome (renal tubular injury with severe hypophosphatemia), has been reported with the use of tenofovir prodrugs in both animal toxicology studies and human trials. In clinical trials with GENVOYA, there have been no cases of Fanconi syndrome or proximal renal tubulopathy.

Patients taking tenofovir prodrugs who have impaired renal function and those taking nephrotoxic agents including non-steroidal anti-inflammatory drugs are at increased risk of developing renal-related adverse reactions.

GENVOYA is not recommended in patients with estimated CrCl of 15 to below 30 mL/min, or in patients with estimated CrCl below 15 mL/min who are not receiving chronic hemodialysis.

7.1 Special Populations

7.1.1 Patients Coinfected with HIV and HBV

The safety and efficacy of GENVOYA have not been established in patients coinfecting with HIV-1 and HBV. It is recommended that all patients with HIV-1 be tested for hepatitis B virus (HBV) before or when initiating ART.

Severe acute exacerbations of hepatitis B (and association with liver decompensation and liver failure in some patients) may occur in patients coinfecting with HBV and HIV-1 after discontinuation of emtricitabine and tenofovir alafenamide, two of the components of GENVOYA.

Hepatic function should be closely monitored with both clinical and laboratory follow-up for at least several months in patients who discontinue GENVOYA and are coinfecting with HIV-1 and HBV. If appropriate, initiation of anti-hepatitis B therapy may be warranted. In patients with advanced liver disease or cirrhosis, post-treatment exacerbation of hepatitis may lead to hepatic decompensation and liver failure. Therefore, in these patients, discontinuation of treatment without initiation of alternative anti-hepatitis B therapy is not recommended.

7.1.2 Pregnant Women

There are not sufficient data to recommend the routine initiation of GENVOYA in women during pregnancy. GENVOYA should not be used in pregnant women unless the potential benefits outweigh the potential risks to the fetus and mother. Lower exposures of elvitegravir and cobicistat have been reported during pregnancy compared to postpartum. Closely monitor viral load during pregnancy, if GENVOYA is continued to be used.

In the embryo-fetal development study in rats, administration of tenofovir alafenamide was associated with reduced fetal body weight and delayed ossification rate at ≥ 100 mg/kg. The no-observed-adverse-effect-level (NOAEL) for embryo-fetal development was 25 mg/kg (approximately 10 times the clinical tenofovir exposure based on AUC).

In the embryo-fetal toxicity study in pregnant rabbits, administration of tenofovir alafenamide resulted in significantly increased number of litters with minor external and visceral anomalies at 100 mg/kg (approximately 90 times the clinical tenofovir exposure based on AUC). The NOAEL for embryo-fetal development was 30 mg/kg/day (approximately 17 times the clinical tenofovir exposure based on AUC).

In the peri- and postnatal development study, administration of tenofovir disoproxil fumarate, another prodrug of tenofovir, to pregnant rats resulted in increased peri/postpartum pup mortality, reduced pup survival, reduced pup body weights, reduced survival of F1 generation, reduced body weight/food consumption of F1 generation and delayed sexual maturation of F1 generation at ≥ 400 mg/kg (approximately 90 times the clinical tenofovir exposure based on AUC). The NOAEL for these effects was 150 mg/kg (approximately 25 times the clinical tenofovir exposure based on AUC). These results are considered relevant to tenofovir alafenamide.

Antiretroviral Pregnancy Registry: To monitor fetal outcomes of pregnant women exposed to ART including GENVOYA, an Antiretroviral Pregnancy Registry has been established. Healthcare providers are encouraged to register patients,
<http://www.apregistry.com>
Telephone: (800) 258-4263
Fax: (800) 800-1052

7.1.3 Nursing Women

HIV-1 infected mothers should not breastfeed their infants to avoid risking postnatal transmission of HIV. Studies in rats have demonstrated that elvitegravir, cobicistat, and tenofovir are secreted in milk. It is not known whether elvitegravir, cobicistat, or tenofovir alafenamide is excreted in human milk.

In humans, samples of breast milk obtained from five HIV-1 infected mothers show that emtricitabine is secreted in human milk at estimated neonatal concentrations 3 to 12 times higher than the emtricitabine IC_{50} but 3 to 12 times lower than the C_{min} achieved from oral administration of emtricitabine. Breastfeeding infants whose mothers are being treated with emtricitabine may be at risk for developing viral resistance to emtricitabine. Other emtricitabine-associated risks in infants breastfed by mothers being treated with emtricitabine are unknown.

Tenofovir-associated risks, including the risk of developing viral resistance to tenofovir, in infants breastfed by mothers being treated with tenofovir alafenamide are unknown.

Because of both the potential for HIV transmission and the potential for serious adverse reactions in nursing infants, **mothers should be instructed not to breastfeed if they are receiving GENVOYA.**

8 ADVERSE REACTIONS

8.1 Adverse Drug Reaction Overview

The following adverse drug reactions are discussed in other sections of the labeling:

- Severe Acute Exacerbations of Hepatitis B [See **SERIOUS WARNINGS AND PRECAUTIONS BOX**]
- Immune Reconstitution Inflammatory Syndrome [See **WARNINGS AND PRECAUTIONS**].
- Lactic Acidosis/Severe Hepatomegaly with Steatosis [See **WARNINGS AND PRECAUTIONS**]

8.2 Clinical Trial Adverse Drug Reactions

Because clinical trials are conducted under very specific conditions the adverse reaction rates observed in the clinical trials may not reflect the rates observed in practice and should not be compared to the rates in the clinical trials of another drug. Adverse drug reaction information from clinical trials is useful for identifying drug-related adverse events and for approximating rates.

Clinical Trials in Treatment-Naïve Adults

The safety assessment of GENVOYA is based on Weeks 48, 96, and 144 pooled data from 1733 patients in two comparative clinical trials, Study GS-US-292-0104 (Study 104) and Study GS-US-292-0111 (Study 111), in antiretroviral treatment-naïve HIV-1 infected adult patients. A total of 866 patients received GENVOYA once daily.

The proportion of patients who discontinued treatment with GENVOYA or STRIBILD due to adverse events, regardless of severity, was 0.9% and 1.5% at Week 48, and 1.3% and 3.3% at Week 144, respectively. Table 2 displays the frequency of adverse reactions (Grades 2-4) greater than or equal to 1% observed in patients receiving GENVOYA.

Table 2. Adverse Reactions^a (Grades 2-4) Reported in $\geq 1\%$ of HIV-1 Infected Treatment-Naïve Adults Receiving GENVOYA in Studies 104 and 111 (Week 48 and 144 Analysis)

	Week 48 and 144 ^b	
	GENVOYA (N=866)	STRIBILD (N=867)
GASTROINTESTINAL DISORDERS		
Nausea	1%	1%
Diarrhea	1%	< 1%
GENERAL DISORDERS AND ADMINISTRATION SITE CONDITIONS		
Fatigue	1%	1%
NERVOUS SYSTEM DISORDERS		
Headache	1%	1%

a Frequencies of adverse reactions are based on Grades 2-4 adverse events attributed to study drugs by the investigator.

b The frequency of adverse reactions are the same for Week 48 through Week 144.

8.3 Less Common Clinical Trial Adverse Drug Reactions (< 1%)

In addition to the adverse reactions presented in Table 2, abdominal pain, dyspepsia, flatulence, rash, and vomiting occurred at a frequency of < 1% and/or at severity of Grade 1 in the GENVOYA group.

Adverse Reactions from Clinical Trials of the Components of GENVOYA

For information on the safety profiles of EMTRIVA[®] or TYBOST[®], consult the Product Monographs for these products.

8.4 Laboratory Abnormalities

The frequency of laboratory abnormalities (Grades 3-4) occurring in at least 2% of patients receiving GENVOYA in Studies 104 and 111 are presented in Table 3.

Table 3. Laboratory Abnormalities (Grades 3-4) Reported in $\geq 2\%$ of Patients Receiving GENVOYA in Studies 104 and 111 (Week 48, and Week 144 Analyses)

Laboratory Parameter Abnormality ^a	Week 48		Week 144	
	GENVOYA (N=866)	STRIBILD (N=867)	GENVOYA (N=866)	STRIBILD (N=867)
Amylase (> 2.0 x ULN)	<2%	3%	3%	5%
ALT (> 5.0 x ULN)	<2%	<2%	3%	3%
AST (> 5.0 x ULN)	<2%	<2%	3%	4%
Creatine Kinase (≥ 10.0 x ULN)	7%	6%	11%	10%
Urine RBC (Hematuria) (> 75 RBC/HPF)	<2%	2%	3%	3%
LDL-cholesterol (fasted) (> 4.92 mmol/L)	5%	2%	11%	5%
Total Cholesterol (fasted) (> 7.77 mmol/L)	<2%	1%	4%	3%
Lipase ^b (≥ 3.0 x ULN)	4%	8%	5%	8%

a. Frequencies are based on treatment-emergent laboratory abnormalities.

b. Lipase test was performed only for patients with serum amylase > 1.5 x ULN (N=90 for GENVOYA arm, N=113 for STRIBILD arm at Week 48; N=127 for GENVOYA arm, N=154 for STRIBILD arm at Week 144).

Cobicistat (a component of GENVOYA) has been shown to increase serum creatinine due to inhibition of tubular secretion of creatinine without affecting renal glomerular function. Increases in serum creatinine occurred by Week 2 of treatment and remained stable through 144 weeks. In treatment-naïve patients, a mean change from baseline of 7.07 ± 10.96 $\mu\text{mol/L}$, 3.54 ± 10.08 $\mu\text{mol/L}$, and 3.54 ± 10.61 $\mu\text{mol/L}$ was observed after 48, 96, and 144 weeks of treatment, respectively.

Serum Lipids

Patients receiving GENVOYA experienced higher increases in serum lipids than those receiving STRIBILD. In the clinical trials of GENVOYA, a similar percentage of patients receiving GENVOYA and STRIBILD were on lipid lowering agents at baseline (2% and 3%, respectively). Similar percentages of subjects in each treatment group initiated

lipid-modifying medications through Week 144, 5.5% and 5.8% in subjects receiving GENVOYA and STRIBILD, respectively.

Changes from baseline in total cholesterol, HDL-cholesterol, LDL-cholesterol, triglycerides, and total cholesterol to HDL ratio at Weeks 48 and 144 are presented in Table 4.

Table 4. Lipid Values, Mean Change from Baseline, Reported in Patients Receiving GENVOYA or STRIBILD in Studies 104 and 111^a (Week 48 and Week 144 Analyses)

	Week 48				Week 144			
	GENVOYA (N=866)		STRIBILD (N=867)		GENVOYA (N=866)		STRIBILD (N=867)	
	Baseline	Change ^b at Week 48	Baseline	Change ^b at Week 48	Baseline	Change ^c at Week 144	Baseline	Change ^c at Week 144
Total Cholesterol (fasted), mmol/L	4.19 [N=757]	+0.78 [N=757]	4.29 [N=742]	+0.34 [N=742]	4.19 [N=647]	+0.80 [N=647]	4.27 [N=627]	+0.36 [N=627]
HDL-cholesterol (fasted), mmol/L	1.19 [N=757]	+0.18 [N=757]	1.16 [N=742]	+0.10 [N=742]	1.21 [N=647]	+0.18 [N=647]	1.19 [N=627]	+0.08 [N=627]
LDL-cholesterol (fasted), mmol/L	2.69 [N=753]	+0.39 [N=753]	2.77 [N=744]	+0.08 [N=744]	2.66 [N=643]	+0.52 [N=643]	2.77 [N=628]	+0.21 [N=628]
Triglycerides (fasted), mmol/L	1.28 [N=757]	+0.33 [N=757]	1.34 [N=742]	+0.11 [N=742]	1.25 [N=647]	+0.33 [N=647]	1.30 [N=627]	+0.19 [N=627]
Total Cholesterol to HDL ratio	3.7 [N=757]	0.2 [N=757]	3.9 [N=742]	0 [N=742]	3.7 [N=647]	0.2 [N=647]	3.8 [N=627]	0.1 [N=627]

- a. Excludes patients who received lipid lowering agents during the treatment period.
- b. The change from baseline is the mean of within patient changes from baseline for patients with both baseline and Week 48 values.
- c. The change from baseline is the mean of within patient changes from baseline for patients with both baseline and Week 144 values.

8.5 Clinical Trials in Virologically Suppressed Patients

No new adverse reactions to GENVOYA were identified through Weeks 48 and 96 in an open-label clinical trial GS-US-292-0109 (Study 109) of virologically suppressed patients who switched from a tenofovir disoproxil fumarate-containing combination regimen to GENVOYA (N=959).

8.6 Clinical Trials in Adult Patients with Renal Impairment

The safety of GENVOYA was evaluated through Weeks 24, 96, and 144 in an open-label clinical trial GS-US-292-0112 (Study 112) in 248 HIV-1 infected patients who were either treatment-naïve (N=6) or virologically suppressed (N=242) with mild to moderate renal impairment (estimated CrCl by Cockcroft-Gault method 30 - 69 mL/min). The safety profile of GENVOYA in patients with mild to moderate renal impairment was similar to that in patients with normal renal function (estimated CrCl \geq 80 mL/min) (see **CLINICAL TRIALS**).

The safety of GENVOYA in 55 virologically suppressed HIV-1 infected patients with end stage renal disease (estimated CrCl by Cockcroft-Gault method $<$ 15 mL/min) on chronic hemodialysis was evaluated through Week 48 in a single arm, open-label clinical study (GS-US-292-1825). The safety profile of GENVOYA in patients with end stage renal disease on chronic hemodialysis was similar to that in patients with normal renal function.

8.7 Clinical Trials in Pediatric Patients (6 to $<$ 18 years of age)

The safety of GENVOYA was evaluated in 50 HIV-1 infected, treatment-naïve pediatric patients between the ages of 12 to $<$ 18 years (\geq 35 kg) through Week 48 in Cohort 1 of an open-label clinical trial GS-US-292-0106 (Study 106) and in 23 virologically suppressed pediatric patients between the ages of 6 to $<$ 12 years (\geq 25 kg) through Week 24 in Cohort 2 of Study 106 (see **CLINICAL TRIALS**). The safety profile in pediatric patients who received treatment with GENVOYA was similar to that in adults.

One 13 year old female patient in Cohort 1 developed unexplained uveitis while receiving GENVOYA that resolved and did not require discontinuation of GENVOYA.

In Cohort 1 of Study 106, 4 patients experienced treatment-emergent worsening in the spine (N = 39) and/or TBLH (N = 37) height-age-adjusted BMD Z-score clinical status from baseline at Week 24, where a relationship to GENVOYA could not be excluded. However, two of these patients subsequently showed improvements in BMD at Week 48. In Cohort 2 of Study 106, 2 patients had significant (at least 4%) lumbar spine BMD loss at Week 24 (see **WARNINGS AND PRECAUTIONS**).

Also within Cohort 2 of Study 106, although all subjects had HIV-1 RNA $<$ 50 copies/mL, there was a decrease from baseline in mean CD4+ cell count at Week 24. All subjects maintained their CD4+ cell counts above 400 cells/mm³ (see **CLINICAL TRIALS, Study results**).

The mean baseline and mean change from baseline in CD4+ cell count and in CD4% from Week 2 to Week 24 are presented in Table 5.

Table 5 Mean Change in CD4+ Count and Percentage from Baseline to Week 24 in Virologically-Suppressed Pediatric Patients from 6 to <12 Years Who Switched to GENVOYA

	Baseline	Mean Change from Baseline			
		Week 2	Week 4	Week 12	Week 24
CD4+ Cell Count (cells/mm ³)	966 (201.7) ^a	-162	-125	-162	-150
CD4%	40 (5.3) ^a	+0.5%	-0.1%	-0.8%	-1.5%

a. Mean (SD)

8.8 Post-Market Adverse Drug Reactions

In addition to the adverse reaction reports from clinical trials, the following possible adverse reactions have been identified during post-approval use of products containing emtricitabine or tenofovir alafenamide. Because these events have been reported voluntarily from a population of unknown size, estimates of frequency cannot be made. These events have been considered possible adverse reactions due to a combination of their seriousness, frequency of reporting or potential causal relationship with treatment. No additional adverse reactions have been identified during post-approval use of other components of GENVOYA.

Emtricitabine

The following adverse experiences have been reported in post-marketing experience without regard to causality; some events represent a single report.

<i>Blood and lymphatic system disorders:</i>	Thrombocytopenia
<i>Gastrointestinal disorders:</i>	Pancreatitis
<i>General disorders and administrative site conditions:</i>	Pyrexia
<i>Metabolism and nutrition disorders:</i>	Lactic acidosis

Tenofovir Alafenamide

<i>Skin and subcutaneous tissue disorders:</i>	Angioedema, urticaria
--	-----------------------

9 DRUG INTERACTIONS

Serious Drug Interactions

Cobicistat, a component of GENVOYA, is a strong inhibitor of cytochrome P450 (CYP3A) and a CYP3A substrate. Coadministration of GENVOYA with drugs that are primarily metabolized by CYP3A may result in increased plasma concentrations of such drugs, which may lead to serious and/or life-threatening events.

Coadministration of GENVOYA with drugs that have active metabolite(s) formed by CYP3A may result in reduced plasma concentrations of these active metabolite(s).

Elvitegravir, a component of GENVOYA, is metabolized by CYP3A. Drugs that induce CYP3A activity may decrease plasma concentrations of cobicistat, elvitegravir and tenofovir alafenamide, which may lead to loss of therapeutic effect of GENVOYA and development of resistance (see **CONTRAINDICATIONS, WARNINGS AND PRECAUTIONS** and **DRUG INTERACTIONS, Table 6—Established and Other Potentially Significant Drug Interactions**).

9.1 Drug-Drug Interactions

GENVOYA is indicated as a complete regimen for the treatment of HIV-1 infection; therefore GENVOYA should not be coadministered with other antiretroviral medications for treatment of HIV-1 infection. Complete information regarding potential drug-drug interactions with other antiretrovirals products is not provided (see **WARNINGS AND PRECAUTIONS, General**).

The drug interactions described in Table 6 are based on studies conducted with GENVOYA, or the components of GENVOYA (elvitegravir, cobicistat, emtricitabine or tenofovir alafenamide) as individual components and/or in combination, or are potential drug interactions that may occur with GENVOYA. The table is not comprehensive.

Potential of GENVOYA to Affect Other Drugs

Cobicistat, a component of GENVOYA, is a strong inhibitor of CYP3A and CYP2D6. The transporters that cobicistat inhibits include p-glycoprotein (P-gp), BCRP, OATP1B1, and OATP1B3. Thus, coadministration of GENVOYA with drugs that are primarily metabolized by CYP3A or CYP2D6, or are substrates of P-gp, BCRP, OATP1B1, or OATP1B3 may result in increased plasma concentrations of such drugs.

Coadministration of GENVOYA with drugs that have active metabolite(s) formed by CYP3A may result in reduced plasma concentrations of these active metabolite(s).

Elvitegravir is a modest inducer of CYP2C9 and may decrease the plasma concentrations of CYP2C9 substrates.

Potential for Other Drugs to Affect One or More Components of GENVOYA

Elvitegravir and cobicistat, components of GENVOYA, are metabolized by CYP3A. Cobicistat is also metabolized, to a minor extent, by CYP2D6. Drugs that induce CYP3A activity are expected to increase the clearance of elvitegravir and cobicistat, resulting in decreased plasma concentration of cobicistat, and thus that of elvitegravir, which may lead to loss of therapeutic effect of GENVOYA and development of resistance.

Coadministration of GENVOYA with other drugs that inhibit CYP3A may decrease the clearance and increase the plasma concentration of cobicistat (see **DRUG INTERACTIONS, Table 6**).

Coadministration of GENVOYA with drugs that inhibit the lysosomal carboxypeptidase cathepsin A (CatA) may decrease metabolism of tenofovir alafenamide to tenofovir in target cells, which may lead to reduced therapeutic effect of GENVOYA and development of resistance (see **DRUG INTERACTIONS, Table 6**).

Tenofovir alafenamide is also a substrate of P-gp and CYP3A4. Drugs that potently induce CYP3A4 activity may decrease the exposure to tenofovir alafenamide, which may result in reduced antiviral activity of GENVOYA and development of resistance (see **DRUG INTERACTIONS, Table 6**).

Established and Other Potentially Significant Interactions

As GENVOYA should not be coadministered with other antiretroviral products, information regarding drug-drug interactions with other antiretroviral products (including protease inhibitors and non-nucleoside reverse transcriptase inhibitors) is not provided (see **WARNINGS AND PRECAUTIONS, General**).

The table is not all-inclusive (see also **CONTRAINDICATIONS**).

Table 6. Established and Other Potentially Significant^a Drug Interactions

Concomitant Drug Class: Drug Name	Effect on Concentration ^b	Clinical Comment
Alpha 1-Adrenoreceptor Antagonist: alfuzosin	↑ alfuzosin	Alfuzosin is primarily metabolized by CYP3A. Coadministration with GENVOYA may result in increased plasma concentrations of alfuzosin, which is associated with the potential for serious and/or life-threatening reactions. Coadministration of GENVOYA and alfuzosin is contraindicated.

Concomitant Drug Class: Drug Name	Effect on Concentration^b	Clinical Comment
<p>Antiarrhythmics: amiodarone bepridil* digoxin disopyramide flecainide systemic lidocaine mexiletine propafenone quinidine</p>	<p>↑ antiarrhythmics</p>	<p>Concentrations of these antiarrhythmic drugs may be increased when coadministered with cobicistat. Caution is warranted and clinical monitoring is recommended upon coadministration of these agents with GENVOYA.</p>
<p>Antibacterials: clarithromycin telithromycin*</p>	<p>↑ clarithromycin ↑ telithromycin ↑ cobicistat</p>	<p>Concentrations of clarithromycin and/or cobicistat may be altered when clarithromycin is coadministered with GENVOYA.</p> <p><u>Patients with CLcr ≥ 60 mL/min:</u> No dose adjustment of clarithromycin is required.</p> <p><u>Patients with CLcr between 30 mL/min and 60 mL/min:</u> The dose of clarithromycin should be reduced by 50%.</p> <p>Concentrations of telithromycin and/or cobicistat may be increased when telithromycin is coadministered with GENVOYA. Clinical monitoring is recommended upon coadministration with GENVOYA.</p>

Concomitant Drug Class: Drug Name	Effect on Concentration^b	Clinical Comment
<p>Anticoagulants: warfarin</p> <p>Direct Oral Anticoagulants (DOACs): apixaban rivaroxaban dabigatran edoxaban</p>	<p>↓ or ↑ warfarin</p> <p>↑ DOACs</p>	<p>Concentrations of warfarin may be affected upon coadministration with GENVOYA. It is recommended that the international normalized ratio (INR) be monitored upon coadministration with GENVOYA.</p> <p>DOACs are primarily metabolized by CYP3A4 and/or transported by P-gp. Coadministration with GENVOYA may result in increased plasma concentrations of the DOAC, which may lead to an increased bleeding risk.</p> <p>Coadministration of a DOAC affected by both P-gp and CYP3A4, including apixaban and rivaroxaban, is contraindicated with GENVOYA.</p> <p>Clinical monitoring and/or dose adjustment is recommended when a DOAC transported by P-gp, including dabigatran or edoxaban, is coadministered with GENVOYA. Refer to the Product Monograph of the coadministered DOAC.</p>
<p>Anticonvulsants: carbamazepine ethosuximide oxcarbazepine phenobarbital phenytoin</p>	<p>↑ ethosuximide</p> <p>↓ elvitegravir</p> <p>↓ cobicistat</p> <p>↓ tenofovir alafenamide</p>	<p>Carbamazepine, a potent CYP3A inducer, decreases cobicistat, elvitegravir and tenofovir alafenamide plasma concentrations, which may result in loss of therapeutic effect and development of resistance. Coadministration of GENVOYA with carbamazepine, phenobarbital, or phenytoin is contraindicated.</p> <p>Coadministration of oxcarbazepine, a CYP3A inducer, may decrease cobicistat and elvitegravir plasma concentrations, which may result in loss of therapeutic effect and development of resistance. Alternative anticonvulsants should be considered.</p> <p>Concentrations of ethosuximide may be increased when coadministered with cobicistat. Clinical monitoring is recommended upon coadministration with GENVOYA.</p>
<p>Antidepressants: Selective Serotonin Reuptake Inhibitors (SSRIs): sertraline TCAs trazodone</p>	<p>↑ SSRIs</p> <p>↔ sertraline</p> <p>↑ TCAs</p> <p>↑ trazodone</p>	<p>Concentrations of sertraline are not affected upon coadministration with GENVOYA. No dose adjustment is required upon coadministration.</p> <p>Concentrations of other antidepressant agents may be increased when coadministered with cobicistat. Dose titration may be required for most drugs of the SSRI class.</p> <p>Concentrations of trazodone may increase upon coadministration with cobicistat. Dose reduction</p>

GENVOYA (elvitegravir/cobicistat/emtricitabine/tenofovir alafenamide*) tablets

*as tenofovir alafenamide hemifumarate

Product Monograph

Concomitant Drug Class: Drug Name	Effect on Concentration^b	Clinical Comment
		should be considered when trazodone is coadministered with GENVOYA.
Antifungals: itraconazole ketoconazole voriconazole	↑ antifungals ↑ cobicistat	Concentrations of ketoconazole, itraconazole and/or cobicistat may increase with coadministration of GENVOYA. When administering with GENVOYA, the maximum daily dose of ketoconazole and itraconazole should not exceed 200 mg per day. Concentrations of voriconazole may be increased when coadministered with cobicistat. Clinical monitoring may be needed upon coadministration with GENVOYA.
Anti-gout: colchicine	↑ colchicine	Dose reductions of colchicine may be required. GENVOYA should not be coadministered with colchicine in patients with renal or hepatic impairment.
Antihistamines: astemizole terfenadine	↑ astemizole ↑ terfenadine	Concentrations of astemizole and terfenadine may be increased when coadministered with cobicistat. Clinical monitoring is recommended when these agents are coadministered with GENVOYA.
Antimycobacterial: rifabutin rifampin rifapentine*	↓ elvitegravir ↓ cobicistat ↓ tenofovir alafenamide	Coadministration of rifampin, rifabutin, and rifapentine, potent CYP3A inducers, may significantly decrease cobicistat, elvitegravir and tenofovir alafenamide plasma concentrations, which may result in loss of therapeutic effect and development of resistance. Coadministration of GENVOYA with rifampin is contraindicated. Coadministration of GENVOYA with rifabutin or rifapentine is not recommended.
Antiplatelets: clopidogrel prasugrel	↓ clopidogrel active metabolite ↔ prasugrel active metabolite	Coadministration of clopidogrel with cobicistat is expected to decrease clopidogrel active metabolite plasma concentrations, which may reduce the antiplatelet activity of clopidogrel. Coadministration of clopidogrel with GENVOYA is not recommended. GENVOYA is not expected to have a clinically relevant effect on plasma concentrations of the active metabolite of prasugrel.
Antipsychotics: Quetiapine	↑ quetiapine	GENVOYA should not be used in combination with quetiapine. Due to CYP3A4 inhibition by cobicistat, concentrations of quetiapine are expected to increase, which can result in serious and/or life-threatening adverse reactions. If coadministration is necessary, monitoring and quetiapine dose

GENVOYA (elvitegravir/cobicistat/emtricitabine/tenofovir alafenamide*) tablets

*as tenofovir alafenamide hemifumarate

Product Monograph

Concomitant Drug Class: Drug Name	Effect on Concentration^b	Clinical Comment
<p>Benzodiazepines: diazepam lorazepam midazolam triazolam</p>	<p>↑ diazepam ↔ lorazepam ↑ midazolam ↑ triazolam</p>	<p>reduction may be required.</p> <p>Midazolam and triazolam are primarily metabolized by CYP3A. Coadministration with GENVOYA may result in increased plasma concentrations of these drugs, which are associated with the potential for serious and/or life-threatening reactions. Coadministration of GENVOYA and orally administered midazolam and triazolam are contraindicated.</p> <p>Concentrations of other benzodiazepines, including diazepam and parenterally administered midazolam, may be increased when administered with GENVOYA. Coadministration should be done in a setting that ensures close clinical monitoring and appropriate medical management in case of respiratory depression and/or prolonged sedation. Dose reduction may be necessary.</p> <p>Based on non-CYP-mediated elimination pathways for lorazepam, no effect on plasma concentrations is expected upon coadministration with GENVOYA.</p>
<p>Beta-Blockers: metoprolol timolol</p>	<p>↑ beta-blockers</p>	<p>Concentrations of beta-blockers may be increased when coadministered with cobicistat. Clinical monitoring is recommended and a dose decrease may be necessary when these agents are coadministered with GENVOYA.</p>
<p>Calcium Channel Blockers: amlodipine diltiazem felodipine nicardipine* nifedipine verapamil</p>	<p>↑ calcium channel blockers</p>	<p>Concentrations of calcium channel blockers may be increased when coadministered with cobicistat. Caution is warranted and clinical monitoring is recommended upon coadministration with GENVOYA.</p>
<p>Systemic Corticosteroids: dexamethasone</p>	<p>↓ elvitegravir ↓ cobicistat</p>	<p>Coadministration of dexamethasone, a CYP3A inducer, may decrease cobicistat and elvitegravir plasma concentrations, which may result in loss of therapeutic effect and development of resistance.</p> <p>Alternative corticosteroids should be considered.</p>
<p>Corticosteroids (all routes excluding cutaneous): betamethasone</p>	<p>↑ corticosteroids</p>	<p>Coadministration of inhaled or nasal corticosteroids and GENVOYA is not recommended unless the potential benefit to the patient outweighs the risks.</p>

GENVOYA (elvitegravir/cobicistat/emtricitabine/tenofovir alafenamide*) tablets

*as tenofovir alafenamide hemifumarate

Product Monograph

Concomitant Drug Class: Drug Name	Effect on Concentration^b	Clinical Comment
budesonide dexamethasone fluticasone mometasone triamcinolone		Coadministration with corticosteroids that are sensitive to CYP3A inhibition can increase the risk for Cushing's syndrome and adrenal suppression, which have been reported during postmarketing use of cobicistat-containing products.
Endothelin Receptor Antagonists: bosentan	↓ elvitegravir ↓ cobicistat	Coadministration with GENVOYA may lead to decreased elvitegravir and/or cobicistat exposures and loss of therapeutic effect and development of resistance. Alternative endothelin receptor antagonists may be considered.
Ergot Derivatives: dihydroergotamine ergonovine* ergotamine methylergonovine	↑ ergot derivatives	Ergot derivatives are primarily metabolized by CYP3A. Coadministration with GENVOYA may result in increased plasma concentrations of these drugs, which is associated with the potential for serious and/or life-threatening reactions. Coadministration of GENVOYA and dihydroergotamine, ergonovine, ergotamine, and methylergonovine are contraindicated.
GI Motility Agents: cisapride*	↑ cisapride	Cisapride is primarily metabolized by CYP3A. Coadministration with GENVOYA may result in increased plasma concentrations of cisapride, which is associated with the potential for serious and/or life-threatening reactions. Coadministration of GENVOYA and cisapride is contraindicated.
Hepatitis C Virus Antiviral Agents: elbasvir/grazoprevir	↑ elbasvir ↑ grazoprevir	Coadministration with GENVOYA may result in increased plasma concentrations of elbasvir and grazoprevir. Coadministration of GENVOYA with elbasvir/grazoprevir is not recommended.
HMG-CoA Reductase Inhibitors: atorvastatin lovastatin rosuvastatin simvastatin	↑ HMG-CoA reductase inhibitors	HMG CoA reductase inhibitors are primarily metabolized by CYP3A. Coadministration with GENVOYA may result in increased plasma concentrations of lovastatin or simvastatin, which are associated with the potential for serious and/or life-threatening reactions. Coadministration of GENVOYA with lovastatin and simvastatin are contraindicated.

Concomitant Drug Class: Drug Name	Effect on Concentration ^b	Clinical Comment
		<p>Concentrations of atorvastatin are increased when coadministered with elvitegravir and cobicistat. Start with the lowest dose of atorvastatin and titrate carefully while monitoring for safety (e.g., myopathy). Do not exceed a dosage of atorvastatin 20 mg daily.</p> <p>Concentrations of rosuvastatin are transiently increased when coadministered with elvitegravir and cobicistat. Dose modifications are not necessary when rosuvastatin is administered in combination with GENVOYA.</p>
<p>Hormonal Contraceptives: drospirenone/ethinyl estradiol norgestimate/ethinyl estradiol</p>	<p>↑ drospirenone ↑ norgestimate ↓ ethinyl estradiol</p>	<p>Plasma concentrations of drospirenone may be increased when coadministered with cobicistat-containing products. Clinical monitoring is recommended due to the potential for hyperkalemia.</p> <p>Coadministration of GENVOYA and a norgestimate/ethinyl estradiol-containing hormonal oral contraceptive is expected to decrease plasma concentrations of ethinyl estradiol and increase norgestimate.</p> <p>Use caution when coadministering GENVOYA and a hormonal contraceptive. The hormonal contraceptive should contain at least 30 mcg of ethinyl estradiol.</p> <p>The effects of increases in the concentration of the progestational component norgestimate are not fully known and can include increased risk of insulin resistance, dyslipidemia, acne and venous thrombosis. The potential unknown risks and benefits associated with coadministration of norgestimate/ethinyl estradiol with GENVOYA should be considered, particularly in women who have risk factors for these events.</p> <p>Coadministration of GENVOYA, or its components, with oral contraceptives containing progestogens other than drospirenone or norgestimate or with other hormonal contraceptives (e.g. contraceptive patch, contraceptive vaginal ring) has not been studied; therefore alternative non-hormonal methods of contraception should be considered.</p>
<p>Immunosuppressants: cyclosporine rapamycin*</p>	<p>↑ immuno-suppressants ↑ tenofovir alafenamide</p>	<p>Concentrations of these immunosuppressant agents may be increased when coadministered with cobicistat.</p>

GENVOYA (elvitegravir/cobicistat/emtricitabine/tenofovir alafenamide*) tablets

*as tenofovir alafenamide hemifumarate

Product Monograph

Concomitant Drug Class: Drug Name	Effect on Concentration^b	Clinical Comment
sirolimus tacrolimus		Coadministration with cyclosporine may result in increased plasma concentration of tenofovir alafenamide. Therapeutic monitoring is recommended upon coadministration with GENVOYA.
Narcotic Analgesics: buprenorphine/ naloxone	↑ buprenorphine ↑ norbuprenorphine ↓ naloxone	Concentrations of buprenorphine and norbuprenorphine are increased when coadministered with GENVOYA. No dose adjustment of buprenorphine/naloxone is required upon coadministration with GENVOYA. Patients should be closely monitored for sedation and cognitive effects.
Inhaled Beta Agonist: salmeterol	↑ salmeterol	Coadministration with GENVOYA may result in increased plasma concentrations of salmeterol, which is associated with the potential for serious and/or life-threatening reactions. Coadministration of salmeterol and GENVOYA is not recommended.
Medications or Oral Supplements Containing Polyvalent Cations (e.g., Mg, Al, Ca, Fe, Zn): calcium or iron supplements, including multivitamins cation-containing antacids or laxatives sucralfate buffered medications	↓ elvitegravir	Elvitegravir plasma concentrations are expected to be lower with medications or oral supplements containing polyvalent cations, including antacids, due to local complexation in the GI tract and not to changes in gastric pH. It is recommended to separate GENVOYA and administration of medications, antacids, or oral supplements containing polyvalent cations by at least 2 hours. For information on other acid reducing agents (e.g. H ₂ -receptor antagonists and proton pump inhibitors), see DRUG INTERACTIONS, Drugs without Clinically Significant Interactions with GENVOYA.
Neuroleptics: perphenazine pimozide risperidone thioridazine*	↑ neuroleptics	Pimozide is primarily metabolized by CYP3A. Coadministration with GENVOYA may result in increased plasma concentrations of pimozide, which is associated with the potential for serious and/or life-threatening reactions. Coadministration of GENVOYA with pimozide is contraindicated. For other neuroleptics, consider reducing the dose of the neuroleptic upon coadministration with GENVOYA.

Concomitant Drug Class: Drug Name	Effect on Concentration^b	Clinical Comment
Phosphodiesterase-5 (PDE-5) Inhibitors: sildenafil tadalafil vardenafil	↑ PDE-5 inhibitors	PDE-5 inhibitors are primarily metabolized by CYP3A. Coadministration with GENVOYA may result in increased plasma concentrations of sildenafil and tadalafil, which may result in PDE-5 inhibitor-associated adverse reactions. Coadministration of GENVOYA with sildenafil for the treatment of pulmonary arterial hypertension is contraindicated. Caution should be exercised, including consideration of dose reduction, when coadministering GENVOYA with tadalafil for the treatment of pulmonary arterial hypertension. For the treatment of erectile dysfunction, it is recommended that a single dose of sildenafil no more than 25 mg in 48 hours, vardenafil no more than 2.5 mg in 72 hours, or tadalafil no more than 10 mg in 72 hours be coadministered with GENVOYA.
Sedative/hypnotics: buspirone orally-administered zolpidem*	↑ sedatives /hypnotics	With sedative/hypnotics, dose reduction may be necessary upon coadministration with GENVOYA and clinical monitoring is recommended.

*Not marketed in Canada

CL_{cr} = creatinine clearance; HMG-CoA = 3-hydroxy-3-methyl-glutaryl-CoA

a This table is not all inclusive.

b ↑ = increase, ↓ = decrease, ↔ = no effect

Drugs without Clinically Significant Interactions with GENVOYA

Based on drug interaction studies conducted with GENVOYA or the components of GENVOYA, no clinically significant drug interactions have been observed or are expected with entecavir, famciclovir, famotidine, ledipasvir/sofosbuvir, omeprazole, ribavirin, sertraline, sofosbuvir, sofosbuvir/velpatasvir, and sofosbuvir/velpatasvir/voxilaprevir.

Methadone exposures are unaffected upon coadministration with elvitegravir and cobicistat. No dose adjustment of methadone is required upon coadministration with GENVOYA.

Assessment of Drug Interactions

Emtricitabine

In vitro and clinical pharmacokinetic drug-drug interaction studies have shown that the potential for CYP-mediated interactions involving emtricitabine with other medicinal products is low.

Emtricitabine is primarily excreted by the kidneys by a combination of glomerular filtration and active tubular secretion. No drug-drug interactions due to competition for renal excretion have been observed; however, coadministration of emtricitabine with drugs that are eliminated by active tubular secretion may increase concentrations of emtricitabine, and/or the coadministered drug.

Drugs that decrease renal function may increase concentrations of emtricitabine.

Tenofovir Alafenamide

Tenofovir alafenamide is a substrate of P-gp and BCRP transporters. Drugs that strongly affect P-gp and BCRP activity may lead to changes in tenofovir alafenamide absorption. However, upon coadministration with cobicistat in GENVOYA, near maximal inhibition of P-gp by cobicistat is achieved leading to increased availability of tenofovir alafenamide with resulting exposures comparable to tenofovir alafenamide 25 mg single agent. As such, tenofovir alafenamide exposures following administration of GENVOYA are not expected to be further increased when used in combination with another P-gp and/or BCRP inhibitor.

In vitro and clinical pharmacokinetic drug-drug interactions studies have shown that the potential for CYP-mediated interactions involving tenofovir alafenamide with other medicinal products is low.

Tenofovir alafenamide is not an inhibitor or inducer of CYP3A *in vivo*.

Drug Interaction Studies

Drug-drug interaction studies were conducted with GENVOYA or various combinations of GENVOYA components including elvitegravir (coadministered with cobicistat or ritonavir), cobicistat administered alone, or tenofovir alafenamide (administered alone or coadministered with emtricitabine).

As GENVOYA should not be administered with other antiretroviral medications, information regarding drug-drug interactions with other antiretroviral agents is not provided (see **WARNINGS AND PRECAUTIONS**).

The effects of coadministered drugs on the exposure of elvitegravir are shown in Table 7. The effects of coadministered drugs on the exposure of tenofovir alafenamide are shown in Table 8. The effects of GENVOYA or its components on the exposure of

coadministered drugs are shown in Table 9.

Table 7. Drug Interactions: Changes in Pharmacokinetic Parameters for Elvitegravir in the Presence of the Coadministered Drug^a

Coadministered Drug	Dose of Coadministered Drug (mg)	Elvitegravir Dose (mg)	Cobicistat or Ritonavir Booster Dose (mg)	N	% Change of Elvitegravir Pharmacokinetic Parameters (90% CI) ^b		
					C _{max}	AUC	C _{min}
Antacids	20 mL single dose given 4 hours before elvitegravir	50 single dose	Ritonavir 100 single dose	8	↔	↔	↔
	20 mL single dose given 4 hours after elvitegravir			10	↔	↔	↔
	20 mL single dose given 2 hours before elvitegravir			11	↔	↔	↔
	20 mL single dose given 2 hours after elvitegravir			10	↔	↔	↔
	20 mL single dose simultaneously administered with elvitegravir	50 single dose	Ritonavir 100 single dose	13	↓47 (↓53 to ↓40)	↓45 (↓50 to ↓40)	↓41 (↓48 to ↓33)
Atorvastatin	10 single dose	150 once daily ^e	Cobicistat 150 once daily ^e	16	↔	↔	↔
Carbamazepine	200 twice daily	150 once daily	Cobicistat 150 once daily	12	↓45 (↓51 to ↓39)	↓69 (↓72 to ↓67)	↓97 (↓98 to ↓60)
Famotidine ^c	40 once daily given 12 hours after elvitegravir	150 once daily	Cobicistat 150 once daily	10	↔	↔	↔
	40 once daily given simultaneously with elvitegravir			16	↔	↔	↔
Ketoconazole	200 twice daily	150 once daily	Ritonavir 100 once daily	18	↔	↑48 (↑36 to	↑67 (↑48 to

GENVOYA (elvitegravir/cobicistat/emtricitabine/tenofovir alafenamide*) tablets

*as tenofovir alafenamide hemifumarate

Product Monograph

Coadministered Drug	Dose of Coadministered Drug (mg)	Elvitegravir Dose (mg)	Cobicistat or Ritonavir Booster Dose (mg)	N	% Change of Elvitegravir Pharmacokinetic Parameters (90% CI) ^b		
					C _{max}	AUC	C _{min}
						↑62)	↑88)
Ledipasvir/ Sofosbuvir	90/400 once daily	150 once daily ^d	Cobicistat 150 once daily ^d	30	↔	↔	↑46 (↑28 to ↑66)
Omeprazole ^c	40 once daily given 2 hours before elvitegravir	50 once daily	Ritonavir 100 once daily	9	↔	↔	↔
	20 once daily given 2 hours before elvitegravir	150 once daily	Cobicistat 150 once daily	11	↔	↔	↔
	20 once daily given 12 hours after elvitegravir			11	↔	↔	↔
Rifabutin	150 once every other day	150 once daily	Cobicistat 150 once daily	12	↔	↓21 (↓26 to ↓15)	↓67 (↓73 to ↓60)
Rosuvastatin	10 single dose	150 once daily	Cobicistat 150 once daily	10	↔	↔	↔
Sertraline	50 single dose	150 once daily ^e	Cobicistat 150 once daily ^e	19	↔	↔	↔
Sofosbuvir/Velpatasvir	400/100 once daily	150 once daily ^e	Cobicistat 150 once daily ^e	24	↔	↔	↔
Sofosbuvir/ Velpatasvir/ Voxilaprevir	400/100/100 + 100 Voxilaprevir ^g once daily	150 once daily ^e	Cobicistat 150 once daily ^e	29	↔	↔	↑32 (↑17 to ↑49)

↑ = Increase; ↓ = Decrease; ↔ = No Effect; NA = Not Applicable

a All interaction studies conducted in healthy volunteers.

b All No Effect Boundaries are 70% -143% unless otherwise specified.

c No Effect Boundary 70% - no upper bound.

d % change of Cobicistat PK parameters (90% CI) was unchanged for C_{max}, ↑59% (↑49%, ↑70%) for AUC, and ↑325% (↑247%, ↑422%) for C_{min}.

e Study conducted with GENVOYA.

f Study conducted with STRIBILD.

g Study conducted with additional voxilaprevir 100 mg to achieve voxilaprevir exposures expected in HCV-infected patients.

Table 8. Drug Interactions: Changes in Pharmacokinetic Parameters for Tenofovir Alafenamide in the Presence of the Coadministered Drug^a

Coadministered Drug	Dose of Coadministered Drug (mg)	Tenofovir Alafenamide (mg)	N	% Change of Tenofovir Alafenamide Pharmacokinetic Parameters (90% CI) ^b		
				C _{max}	AUC	C _{min}
Cobicistat	150 once daily	8 once daily	12	↑183 (↑120 to ↑265)	↑165 (↑129 to ↑207)	NA
Ledipasvir/Sofosbuvir	90/400 once daily	10 once daily ^d	30	↔	↔	NA
Efavirenz	600 once daily	40 once daily ^c	11	↓22 (↓42 to ↑5)	↔	NA
Sertraline	50 single dose	10 once daily ^d	19	↔	↔	NA
Sofosbuvir/Velpatasvir	400/100 once daily	10 once daily ^d	24	↓20 (↓32 to ↓6)	↔	NA
Sofosbuvir/ Velpatasvir/Voxilaprevir	400/100/100 + 100 Voxilaprevir ^e once daily	10 once daily ^d	29	↓21 (↓32 to ↓8)	↔	NA

NA = Not Available/Not Applicable

a All interaction studies conducted in healthy volunteers.

b All No Effect Boundaries are 70% -143% unless otherwise specified.

c Study conducted with DESCOVY.

d Study conducted with GENVOYA.

e Study conducted with additional voxilaprevir 100 mg to achieve voxilaprevir exposures expected in HCV-infected patients.

Table 9. Drug Interactions: Changes in Pharmacokinetic Parameters for Coadministered Drug in the Presence of GENVOYA or the Individual Components^a

Coadministered Drug	Dose of Coadministered Drug (mg)	Elvitegravir Dose ^b (mg)	Cobicistat Booster Dose (mg)	Tenofovir Alafenamide (mg)	N	% Change of Coadministered Drug Pharmacokinetic Parameters (90% CI) ^b		
						C _{max}	AUC	C _{min}
Atorvastatin	10 single dose	150 once daily ^f	150 once daily ^f	10 once daily ^f	16	↑132 (↑91 to ↑182)	↑160 (↑131 to ↑193)	NC
Buprenorphine	16 - 24 once daily	150 once daily	150 once daily	NA	17	↔	↑35 (↑18 to ↑55)	↑66 (↑43 to ↑93)
Norbuprenorphine						↑24 (↑3 to ↑49)	↑42 (↑22 to ↑67)	↑57 (↑31 to ↑88)
Carbamazepine	200 twice daily	150 once daily	150 once daily	NA	12	↑40 (↑32 to ↑49)	↑43 (↑36 to ↑52)	↑51 (↑41 to ↑62)
Carbamazepine-10,11-epoxide						↔	↓35 (↓37 to ↓34)	↓41 (↓43 to ↓39)
Desipramine ^c	50 single dose	NA	150 once daily	NA	8	↑24 (↑8 to ↑44)	↑65 (↑36 to ↑102)	NA
Digoxin ^c	0.5 single dose	NA	150 once daily	NA	22	↑41 (↑29 to ↑55)	↔	NA

GENVOYA (elvitegravir/cobicistat/emtricitabine/tenofovir alafenamide*) tablets

*as tenofovir alafenamide hemifumarate

Product Monograph

Coadministered Drug	Dose of Coadministered Drug (mg)	Elvitegravir Dose ^b (mg)	Cobicistat Booster Dose (mg)	Tenofovir Alafenamide (mg)	N	% Change of Coadministered Drug Pharmacokinetic Parameters (90% CI) ^b		
						C _{max}	AUC	C _{min}
Ledipasvir	90 once daily	150 once daily ^f	150 once daily ^f	10 once daily ^f	30	↑65 (↑53 to ↑78)	↑79 (↑64 to ↑96)	↑93 (↑74 to ↑115)
Sofosbuvir	400 once daily					↑28 (↑13 to ↑47)	↑47 (↑35 to ↑59)	NA
GS-331007 ⁱ						↑29 (↑24 to ↑35)	↑48 (↑44 to ↑53)	↑66 (↑60 to ↑73)
Naloxone	4 - 6 once daily	150 once daily	150 once daily	NA	17	↓28 (↓39 to ↓15)	↓28 (↓41 to ↓13)	NA
Norgestimate ^c / ethinyl estradiol ^c	0.180/0.215/ 0.250 norgestimate once daily	150 once daily ^d	150 once daily ^d	NA	13	↑108 (↑100 to ↑117)	↑126 (↑115 to ↑137)	↑167 (↑143 to ↑192)
	0.025 ethinyl estradiol once daily					↔	↓25 (↓31 to ↓19)	↓44 (↓48 to ↓39)
Norelgestromin	0.180/0.215/ 0.250 norgestimate once daily / 0.025 ethinyl estradiol once daily	NA	NA	25 once daily ^e	15	↔	↔	↔
Norgestrel						↔	↔	↔
Ethinyl estradiol						↔	↔	↔

GENVOYA (elvitegravir/cobicistat/emtricitabine/tenofovir alafenamide*) tablets
 *as tenofovir alafenamide hemifumarate
 Product Monograph

Coadministered Drug	Dose of Coadministered Drug (mg)	Elvitegravir Dose ^b (mg)	Cobicistat Booster Dose (mg)	Tenofovir Alafenamide (mg)	N	% Change of Coadministered Drug Pharmacokinetic Parameters (90% CI) ^b		
						C _{max}	AUC	C _{min}
R-Methadone	80-120 daily	150 once daily	150 once daily	NA	11	↔	↔	↔
S-Methadone						↔	↔	↔
Sertraline	50 single dose	150 once daily ^f	150 once daily ^f	10 once daily ^f	19	↔	↔	NA
Rifabutin	150 once every other day	150 once daily	150 once daily	NA	12	↔ ^g	↔ ^g	↔ ^g
25-O-desacetyl-rifabutin					12	↑384 (↑309 to ↑474) ^g	↑525 (↑408 to ↑669) ^g	↑394 (↑304 to ↑504) ^g
Rosuvastatin	10 single dose	150 once daily	150 once daily	NA	10	↑89 (↑48 to ↑142) ^h	↑38 (↑13 to ↑67)	NA
Sofosbuvir	400/100 once daily	150 once daily ^f	150 once daily ^f	10 once daily ^f	24	↑23 (↑7 to ↑42)	↑37 (↑24 to ↑52)	NA
GS-331007 ⁱ						↑29 (↑25 to ↑33)	↑48 (↑43 to ↑53)	↑58 (↑52 to ↑65)
Velpatasvir						↑30 (↑17 to ↑45)	↑50 (↑35 to ↑66)	↑60 (↑44 to ↑78)

GENVOYA (elvitegravir/cobicistat/emtricitabine/tenofovir alafenamide*) tablets

*as tenofovir alafenamide hemifumarate

Product Monograph

Coadministered Drug	Dose of Coadministered Drug (mg)	Elvitegravir Dose ^b (mg)	Cobicistat Booster Dose (mg)	Tenofovir Alafenamide (mg)	N	% Change of Coadministered Drug Pharmacokinetic Parameters (90% CI) ^b		
						C _{max}	AUC	C _{min}
Sofosbuvir	400 once daily	150 once daily ^f	150 once daily ^f	10 once daily ^f	29	↑27 (↑9 to ↑48)	↔	NC
GS-331007 ⁱ						↔	↑43 (↑39 to ↑47)	NC
Velpatasvir	100 once daily					↔	↔	↑46 (↑30 to ↑64)
Voxilaprevir	100 + 100 ⁱ once daily					↑92 (↑63 to ↑126)	↑171 (↑130 to ↑219)	↑350 (↑268 to ↑450)

NA = Not Available/Not Applicable

- a. All interaction studies conducted in healthy volunteers.
- b. All No Effect Boundaries are 70% -143% unless otherwise specified.
- c. No Effect Boundary 80%-125%.
- d. Study conducted with STRIBILD.
- e. Study conducted with DESCOVY (emtricitabine/tenofovir alafenamide).
- f. Study conducted with GENVOYA.
- g. Comparison based on rifabutin 300 mg once daily.
- h. No Effect Boundary 70%-175% for rosuvastatin C_{max}.
- i. The predominant circulating metabolite of sofosbuvir.
- j. Study conducted with additional voxilaprevir 100 mg to achieve voxilaprevir exposures expected in HCV-infected patients.

9.2 Drug-Food Interactions

Relative to fasting conditions, administration with a light meal (~373 kcal, 20% fat) increased the mean systemic exposure of elvitegravir by 34%. The alterations in mean systemic exposures of cobicistat and emtricitabine were not clinically significant.

Relative to fasting conditions, administration with a high fat meal (~ 800 kcal, 50% fat) increased the mean systemic exposure of elvitegravir by 87%. The alterations in mean systemic exposures of cobicistat and emtricitabine were not clinically significant.

Relative to fasting conditions, administration of GENVOYA with a light meal (~400 kcal, 20% fat) or high-fat meal (~800 kcal, 50% fat) increased the mean systemic exposures of tenofovir alafenamide by approximately 15% and 18%, respectively. The alterations in mean systemic exposures of tenofovir alafenamide were not clinically significant.

GENVOYA should be taken with food.

9.3 Drug-Herb Interactions

Coadministration of St. John's wort, a potent CYP3A inducer, may significantly decrease cobicistat, elvitegravir and tenofovir alafenamide plasma concentrations, which may result in loss of therapeutic effect and development of resistance.

Coadministration of GENVOYA with St. John's wort is contraindicated.

9.4 Drug-Laboratory Interactions

Interactions of GENVOYA with laboratory tests have not been established.

10 ACTION AND CLINICAL PHARMACOLOGY

10.1 Mechanism of Action

GENVOYA is a fixed-dose combination of antiviral drugs elvitegravir (boosted by the pharmacokinetic enhancer cobicistat), emtricitabine and tenofovir alafenamide.

Elvitegravir

Elvitegravir is an HIV-1 integrase strand transfer inhibitor (INSTI). Integrase is an HIV-1 encoded enzyme that is required for viral replication. Inhibition of integrase prevents the integration of HIV-1 DNA into host genomic DNA, blocking the formation of the HIV-1 provirus and propagation of the viral infection. Elvitegravir does not inhibit human topoisomerases I or II.

Cobicistat

Cobicistat is a selective, mechanism-based inhibitor of cytochromes P450 of the CYP3A subfamily. Inhibition of CYP3A-mediated metabolism by cobicistat enhances the systemic exposure of CYP3A substrates, such as elvitegravir, where bioavailability is limited and half-life is shortened by CYP3A-dependent metabolism.

Emtricitabine

Emtricitabine is a nucleoside analogue of 2'-deoxycytidine. Emtricitabine is phosphorylated by cellular enzymes to form emtricitabine triphosphate. Emtricitabine triphosphate inhibits HIV replication through incorporation into viral DNA by the HIV reverse transcriptase, which results in DNA chain-termination.

Emtricitabine has activity that is specific to human immunodeficiency virus (HIV-1 and HIV-2) and hepatitis B virus.

Emtricitabine triphosphate is a weak inhibitor of mammalian DNA polymerases that include mitochondrial DNA polymerase γ and there was no evidence of toxicity to mitochondria *in vitro* and *in vivo*.

Tenofovir Alafenamide

Tenofovir alafenamide is a phosphoramidate prodrug of tenofovir (2'-deoxyadenosine monophosphate analogue) and differs from tenofovir disoproxil fumarate which is another prodrug of tenofovir. Tenofovir alafenamide is permeable into cells and due to increased plasma stability, and intracellular activation through hydrolysis by cathepsin A, tenofovir alafenamide is efficient in loading tenofovir into peripheral blood mononuclear cells (PBMCs) (including lymphocytes and other HIV target cells) and macrophages. Intracellular tenofovir is subsequently phosphorylated to the pharmacologically active metabolite tenofovir diphosphate. Tenofovir diphosphate inhibits HIV replication through incorporation into viral DNA by the HIV reverse transcriptase, which results in DNA chain-termination.

Tenofovir has activity that is specific to human immunodeficiency virus (HIV-1 and HIV-2). Tenofovir alafenamide displayed antiviral activity in cell culture against all HIV-1 groups. Tenofovir diphosphate is a weak inhibitor of mammalian DNA polymerases that include mitochondrial DNA polymerase γ . In the *in vitro* study, tenofovir alafenamide did not significantly affect mitochondrial DNA in HepG2 cells.

10.2 Pharmacodynamics

Effects on Electrocardiogram

Thorough QT studies have been conducted for elvitegravir, cobicistat, and tenofovir alafenamide. The effect of emtricitabine or the combination regimen GENVOYA on the QT interval is not known.

The electrocardiographic effects of cobicistat were determined in a study of 48 healthy adult patients. Cobicistat did not prolong the QTcF interval at exposures 2- and 4-fold above the recommended therapeutic dose. A modest increase in PR interval (+9.6 msec) occurred around C_{max} , 3 to 5 hours after dosing with 250 mg of cobicistat. This finding was not considered to be clinically significant.

In a thorough QT/QTc study in 126 healthy patients, elvitegravir at therapeutic or suprathreshold dose approximately 2-fold the recommended therapeutic dose did not affect the QT/QTc interval and did not prolong the PR interval.

In a thorough QT/QTc study in 48 healthy patients, tenofovir alafenamide at the therapeutic dose or at a suprathreshold dose approximately 5 times the recommended therapeutic dose did not affect the QT/QTc interval and did not prolong the PR interval.

Effects on Serum Creatinine

The effect of cobicistat on serum creatinine was investigated in a Phase 1 study in patients with normal renal function (estimated CrCl \geq 80 mL/min; N = 18) and mild to moderate renal impairment (estimated CrCl: 50-79 mL/min; N = 12). A statistically significant change of estimated CrCl by Cockcroft-Gault method from baseline was observed after 7 days of treatment with cobicistat 150 mg among patients with normal renal function (-9.9 ± 13.1 mL/min) and mild to moderate renal impairment (-11.9 ± 7.0 mL/min). These decreases in estimated CrCl by Cockcroft-Gault method were reversible after cobicistat was discontinued. The actual glomerular filtration rate, as determined by the clearance of probe drug iohexol, was not altered from baseline following treatment of cobicistat among patients with normal renal function and mild to moderate renal impairment, indicating cobicistat inhibits tubular secretion of creatinine, reflected as a reduction in estimated CrCl by Cockcroft-Gault method, without affecting the actual glomerular filtration rate.

10.3 Pharmacokinetics

Absorption and Bioavailability

GENVOYA: Following oral administration with food in HIV-1 infected adult patients, peak plasma concentrations were observed 4 hours post-dose for elvitegravir, 3 hours

post-dose for cobicistat, 3 hours post-dose for emtricitabine, and 1 hour post-dose for tenofovir alafenamide (see Table 10 for additional pharmacokinetic parameters).

Table 10. Pharmacokinetic Parameters of Elvitegravir, Cobicistat, Emtricitabine, Tenofovir Alafenamide, and its Metabolite Tenofovir Exposure Following Oral Administration of GENVOYA with Food in HIV-Infected Adults

Parameter Mean (CV%)	Elvitegravir ^a	Cobicistat ^b	Emtricitabine ^b	Tenofovir Alafenamide ^c	Tenofovir ^d
C _{max} (microgram per mL)	1.7 (22.5)	1.1 (35.6)	1.9 (27.1)	0.16 (51.1)	0.02 (26.1)
AUC _{tau} (microgram•hour per mL)	23.0 (32.5)	8.3 (46.1)	12.7 (35.3)	0.21 (71.8)	0.29 (27.4)
C _{trough} (microgram per mL)	0.45 (57.7)	0.05 (262.8)	0.14 (174.2)	NA	0.01 (28.5)

CV = Coefficient of Variation; NA = Not Applicable

- a. From Population Pharmacokinetic analysis, N=419.
- b. From Intensive Pharmacokinetic analysis, N=61-62, except cobicistat C_{trough} N=53.
- c. From Population Pharmacokinetic analysis, N=539.
- d. From Population Pharmacokinetic analysis in Studies 104 and 111, N=841.

Distribution

Elvitegravir

Elvitegravir is 98-99% bound to human plasma proteins and binding is independent of drug concentration over the range of 1 ng/mL to 1.6 µg/mL. The mean plasma to blood drug concentration ratio was 1.37.

Cobicistat

Cobicistat is 97-98% bound to human plasma proteins and the mean plasma to blood drug concentration ratio was 2.

Emtricitabine

In vitro binding of emtricitabine to human plasma proteins is < 4% and is independent of concentration over the range of 0.02 to 200 µg/mL. At peak plasma concentration, the mean plasma to blood drug concentration ratio was ~ 1.0 and the mean semen to plasma drug concentration ratio was ~ 4.0.

Tenofovir Alafenamide

The binding of tenofovir to human plasma proteins is < 0.7% and is independent of concentration over the range of 0.01–25 µg/mL. The binding of tenofovir alafenamide to

human plasma proteins in samples collected during clinical studies was approximately 80%.

Metabolism

Elvitegravir

The majority of elvitegravir metabolism is mediated by CYP3A enzymes. Elvitegravir also undergoes glucuronidation via UGT1A1/3 enzymes.

Cobicistat

Cobicistat is metabolized by CYP3A and to a minor extent by CYP2D6 enzymes and does not undergo glucuronidation.

Emtricitabine

Emtricitabine is not significantly metabolized.

Tenofovir Alafenamide

Metabolism is a major elimination pathway for tenofovir alafenamide in humans, accounting for > 80% of an oral dose. *In vitro* studies have shown that tenofovir alafenamide is metabolized to tenofovir (major metabolite) by cathepsin A in peripheral blood mononuclear cells (PBMCs) (including lymphocytes and other HIV target cells) and macrophages; and by carboxylesterase-1 in hepatocytes. Tenofovir alafenamide is a substrate of P-gp and BCRP transporters, and is minimally metabolized by CYP3A4. Upon coadministration with the moderate CYP3A inducer probe efavirenz, tenofovir alafenamide exposure was unaffected.

In vivo, tenofovir alafenamide is hydrolyzed within cells to form tenofovir (major metabolite), which is phosphorylated to the active metabolite, tenofovir diphosphate. In human clinical studies, a 10 mg oral dose of tenofovir alafenamide in GENVOYA resulted in tenofovir diphosphate concentrations > 4-fold higher in PBMCs and > 90% lower concentrations of tenofovir in plasma as compared to a 300 mg oral dose of tenofovir disoproxil fumarate in STRIBILD.

In vitro, tenofovir alafenamide is not an inhibitor of CYP1A2, CYP2B6, CYP2C8, CYP2C9, CYP2C19, CYP2D6, or UGT1A1. Tenofovir alafenamide is not an inhibitor or inducer of CYP3A *in vivo*.

Excretion

Elvitegravir

The median terminal plasma half-life of elvitegravir is approximately 12.9 hours. After single dose administration of [¹⁴C] elvitegravir (coadministered with 100 mg ritonavir),

94.8% and 6.7% of the administered dose was excreted in feces and urine, respectively.

Cobicistat

The median terminal plasma half-life of cobicistat is approximately 3.5 hours. With single dose administration of [¹⁴C] cobicistat after multiple dosing of cobicistat for six days, 86.2% and 8.2% of the administered dose was excreted in feces and urine, respectively.

Emtricitabine

Emtricitabine is primarily excreted in the urine by a combination of glomerular filtration and active tubular secretion.

Tenofovir Alafenamide

Tenofovir alafenamide is eliminated following metabolism to tenofovir. Tenofovir is eliminated from the body in the feces and urine by both glomerular filtration and active tubular secretion. Tenofovir alafenamide and tenofovir have a median plasma half-life of 0.51 and 32.37 hours, respectively. Renal excretion of intact tenofovir alafenamide is a minor pathway with less than 1% of the dose eliminated in urine. The pharmacologically active metabolite, tenofovir diphosphate, has a half-life of 150-180 hours within PBMCs.

Special Populations and Conditions

Pediatrics (≥ 6 to < 18 years of age)

Exposures of elvitegravir, cobicistat, emtricitabine, and tenofovir alafenamide achieved in 24 pediatric patients aged 12 to < 18 years who received GENVOYA in Study 106 (Table 11) were similar to exposures achieved in treatment-naïve adults (Table 10) following administration of GENVOYA.

Table 11 Multiple Dose Pharmacokinetic Parameters of Elvitegravir, Cobicistat, Emtricitabine, Tenofovir Alafenamide (TAF) and its Metabolite Tenofovir Following Oral Administration of GENVOYA in HIV-Infected Pediatric Patients Aged 12 to less than 18 Years^a

Parameter Mean (CV%)	Elvitegravir	Cobicistat	Emtricitabine	Tenofovir Alafenamide	Tenofovir
C _{max} (microgram per mL)	2.2 (19.2)	1.2 (35.0)	2.3 (22.5)	0.17 (64.4)	0.02 (23.7)
AUC ₀₋₂₄ (microgram•hour per mL)	23.8 (25.5)	8.2 ^b (36.1)	14.4 (23.9)	0.20 ^b (50.0)	0.29 ^b (18.8)
C _{trough} (microgram per mL)	0.30 (81.0)	0.03 ^c (180.0)	0.10 ^b (38.9)	NA	0.01 (21.4)

CV = Coefficient of Variation; NA = Not Applicable

a. From Intensive PK analysis in a trial in treatment-naïve pediatric patients with HIV-1 infection, cohort 1 of Study 106 (N=24).

b. N=23

c. N=15

Exposures of elvitegravir, cobicistat, emtricitabine, and tenofovir alafenamide achieved in 23 pediatric patients between the ages of 6 to < 12 years (≥ 25 kg) who received GENVOYA in Study 106 (Table 12) were generally higher (20-80%) than exposures achieved in adults (Table 10); however, the increase was not considered clinically relevant as the safety profiles were similar in adult and pediatric patients.

Table 12 Multiple Dose Pharmacokinetic Parameters of Elvitegravir, Cobicistat, Emtricitabine, Tenofovir Alafenamide (TAF) and its Metabolite Tenofovir Following Oral Administration of GENVOYA in HIV-Infected Pediatric Patients Aged 6 to less than 12 Years^a

Parameter Mean (CV%)	Elvitegravir	Cobicistat	Emtricitabine	Tenofovir Alafenamide	Tenofovir
C _{max} (microgram per mL)	3.1 (38.7)	2.1 (46.7)	3.4 (27.0)	0.31 (61.2)	0.03 (20.8)
AUC ₀₋₂₄ (microgram•hour per mL)	33.8 ^b (57.8)	15.9 ^c (51.7)	20.6 ^b (18.9)	0.33 (44.8)	0.44 (20.9)
C _{trough} (microgram per mL)	0.37 (118.5)	0.1 (168.7)	0.11 (24.1)	NA	0.02 (24.9)

CV = Coefficient of Variation; NA = Not Applicable

a. From Intensive PK analysis in a trial in virologically-suppressed pediatric patients with HIV-1 infection, cohort 2 of Study 106 (N=23).

b. N=22

c. N=20

Geriatrics (≥ 65 years of age)

Pharmacokinetic-pharmacodynamic analysis of HIV-infected patients in Phase 2 and Phase 3 trials of GENVOYA showed that within the age range studied (8 to 82 years), age did not have a clinically relevant effect on exposures of tenofovir alafenamide.

Race

Elvitegravir, Cobicistat and Tenofovir Alafenamide: Population pharmacokinetic analysis in HIV-1 infected patients indicated that race had no clinically relevant effect on the exposure of cobicistat-boosted elvitegravir, cobicistat or tenofovir alafenamide.

Emtricitabine: No pharmacokinetic differences due to race have been identified following the administration of emtricitabine.

Gender

No clinically relevant pharmacokinetic differences have been observed between men and women for cobicistat-boosted elvitegravir, emtricitabine and tenofovir alafenamide.

Hepatic Impairment

Elvitegravir and Cobicistat: A study of the pharmacokinetics of cobicistat-boosted elvitegravir was performed in healthy patients and patients with moderate hepatic impairment. No clinically relevant differences in elvitegravir or cobicistat pharmacokinetics were observed between patients with moderate hepatic impairment (Child-Pugh Class B) and healthy patients. No dosage adjustment of elvitegravir or cobicistat is necessary for patients with mild to moderate hepatic impairment. The effect of severe hepatic impairment (Child-Pugh Class C) on the pharmacokinetics of elvitegravir or cobicistat has not been studied.

Emtricitabine: The pharmacokinetics of emtricitabine has not been studied in patients with hepatic impairment; however, emtricitabine is not significantly metabolized by liver enzymes, so the impact of liver impairment should be limited.

Tenofovir Alafenamide: Clinically relevant changes in the pharmacokinetics of tenofovir alafenamide or its metabolite tenofovir were not observed in patients with mild, moderate, or severe hepatic impairment; no tenofovir alafenamide dose adjustment is required in patients with hepatic impairment.

Renal Impairment

Mild to Moderate Renal Impairment (estimated CrCl \geq 30 and $<$ 70 mL/min)

The safety, virologic, and immunologic responses of GENVOYA in HIV-1 infected patients with mild to moderate renal impairment (estimated CrCl by Cockcroft-Gault method 30 - 69 mL/min) were evaluated in 242 virologically suppressed patients and 6 treatment-naïve patients in an open-label trial, Study 112. The safety profile of GENVOYA in patients with mild to moderate renal impairment was similar to that in patients with normal renal function.

Severe Renal Impairment (estimated CrCl \geq 15 and $<$ 30 mL/minute)

No clinically relevant differences in elvitegravir, cobicistat, tenofovir alafenamide, or tenofovir pharmacokinetics were observed between healthy patients and patients with severe renal impairment (estimated CrCl \geq 15 and $<$ 30 mL/min) in Phase 1 studies of cobicistat-boosted elvitegravir or of tenofovir alafenamide, respectively. In a separate Phase 1 study of emtricitabine alone, emtricitabine exposures were increased in subjects with severe renal impairment. The safety of GENVOYA has not been established in subjects with estimated CrCl \geq 15 mL/min and $<$ 30 mL/min.

End Stage Renal Disease (estimated CrCl $<$ 15 mL/minute)

Exposures of emtricitabine and tenofovir in 12 subjects with end stage renal disease (estimated CrCl $<$ 15 mL/minute) on chronic hemodialysis who received GENVOYA in Study 1825 were significantly higher than in subjects with normal renal function.

However, the safety profile of GENVOYA in subjects with end stage renal disease on chronic hemodialysis was similar to that in subjects with normal renal function. No clinically relevant differences in elvitegravir, cobicistat, or tenofovir alafenamide pharmacokinetics were observed in patients with end stage renal disease as compared to those with normal renal function.

There are no pharmacokinetic data on elvitegravir, cobicistat, or tenofovir alafenamide in patients with estimated CrCl < 15 mL/min not on chronic hemodialysis.

Hepatitis B and/or Hepatitis C Virus Coinfection

Elvitegravir: Limited data from population pharmacokinetic analysis (N=24) indicated that hepatitis B and/or C virus infection had no clinically relevant effect on the exposure of cobicistat-boosted elvitegravir.

Cobicistat: There were insufficient pharmacokinetic data in the clinical trials to determine the effect of hepatitis B and/or C virus infection on the pharmacokinetics of cobicistat.

Emtricitabine and Tenofovir Alafenamide: Pharmacokinetics of emtricitabine and tenofovir alafenamide have not been fully evaluated in patients coinfecting with hepatitis B and/or C virus.

11 STORAGE AND STABILITY

Store below 30 °C (86 °F).

- Keep container tightly closed.
- Dispense only in original container.
- Do not use if seal over bottle opening is broken or missing.

12 SPECIAL HANDLING INSTRUCTIONS

There are no special handling instructions.

PART II: SCIENTIFIC INFORMATION

13 PHARMACEUTICAL INFORMATION

GENVOYA is a fixed-dose combination, single tablet regimen containing elvitegravir, cobicistat, emtricitabine, and tenofovir alafenamide hemifumarate. Elvitegravir is an HIV-1 integrase strand transfer inhibitor (INSTI). Cobicistat is a mechanism-based inhibitor of cytochrome P450 (CYP) enzymes of the CYP3A family. Emtricitabine is a synthetic nucleoside analog of cytidine. Tenofovir alafenamide, a nucleoside reverse transcriptase inhibitor (NRTI), is a prodrug of tenofovir converted *in vivo* to tenofovir, and acyclic nucleoside phosphanate (nucleotide) analog of adenosine 5'-monophosphate.

GENVOYA tablets are for oral administration. Each tablet contains 150 mg of elvitegravir, 150 mg of cobicistat, 200 mg of emtricitabine, and 10 mg of tenofovir alafenamide (which is equivalent to 11.2 mg of tenofovir alafenamide hemifumarate).

The tablets also include the following inactive ingredients: Lactose Monohydrate, Microcrystalline Cellulose, Croscarmellose Sodium, Hydroxypropyl Cellulose, Silicon Dioxide, Sodium Lauryl Sulfate, and Magnesium Stearate. The tablets are coated with a coating material containing Polyvinyl Alcohol, Titanium Dioxide, Polyethylene Glycol, Talc, Indigo Carmine Aluminum Lake, and Iron Oxide Yellow.

Elvitegravir

Drug Substance

Common Name: elvitegravir (USAN)

Chemical Name: 3-quinolinecarboxylic acid, 6-[(3-chloro-2-fluorophenyl)methyl]-1,4-dihydro-1-[(1S)-1-(hydroxymethyl)-2-methylpropyl]-7-methoxy-4-oxo-

Empirical Formula: C₂₃H₂₃ClFNO₅

Molecular Weight: 447.9

Structural Formula:

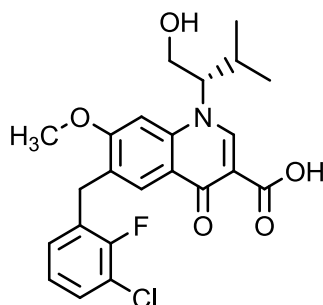

Physicochemical Properties:

Description: Elvitegravir is a white to pale yellow powder.

Solubility: The solubility is approximately 0.0003 mg/mL in water at 20 °C. The partition coefficient (log P) cannot be determined due to its low solubility in aqueous media and the pKa is 6.6 (carboxylic acid).

Cobicistat

Drug Substance

Common Name: cobicistat (USAN)

Chemical Name: 1,3-Thiazol-5-ylmethyl [(2R,5R)-5-[[[(2S)-2-[(methyl{[2-(propan-2-yl)-1,3-thiazol-4-yl]methyl}carbonyl)amino]-4-(morpholin-4-yl)butanoyl]amino]-1,6-diphenylhexan-2-yl]carbamate

Empirical Formula: C₄₀H₅₃N₇O₅S₂

Molecular Weight: 776.0

Structural Formula:

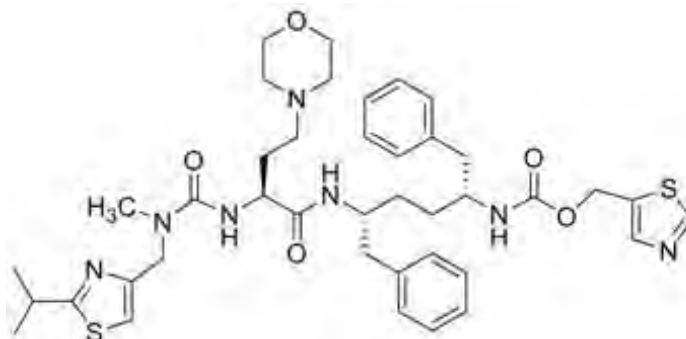

Physicochemical Properties:

Description: Cobicistat is adsorbed onto silicon dioxide. Cobicistat is a white to pale yellow solid.

Solubility: The solubility is approximately 0.1 mg/mL in water at 20 °C. The partition coefficient (log P) is 4.3 (n-octanol/phosphate buffer pH 8.5) and the pKa is pKa1 = 1.8 (thiazole group), pKa2 = 2.5 (alkylthiazole group), pKa3 = 6.4 (morpholino group).

Emtricitabine

Drug Substance

Common Name: emtricitabine (USAN)

Chemical Name: 5-fluoro-1-(2R,5S)-[2-(hydroxymethyl)-1,3-oxathiolan-5-yl]cytosine

Empirical Formula: C₈H₁₀FN₃O₃S

Molecular Weight: 247.24

Structural Formula:

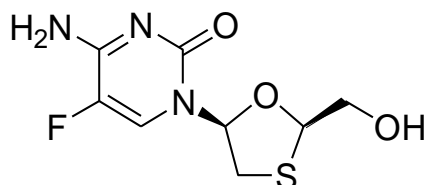

Physicochemical Properties:

Description: Emtricitabine is a white to off-white crystalline powder.

Solubility: The solubility is approximately 112 mg/mL in water at 25 °C. The partition coefficient (log P) is -0.43 and the pKa is 2.65.

Tenofovir alafenamide

Drug Substance

Common Name: Tenofovir alafenamide hemifumarate
Tenofovir alafenamide fumarate (USAN)

Chemical Name: Propan-2-yl N-[(S)-({[(2R)-1-(6-amino-9H-purin-9-yl)propan-2-yl]-oxy}methyl)(phenoxy)phosphoryl]-l-alaninate, (2E)-but-2-enedioate (2:1)

Empirical Formula: $C_{21}H_{29}O_5N_6P \cdot 1/2(C_4H_4O_4)$

Molecular Weight: 534.5

Structural Formula:

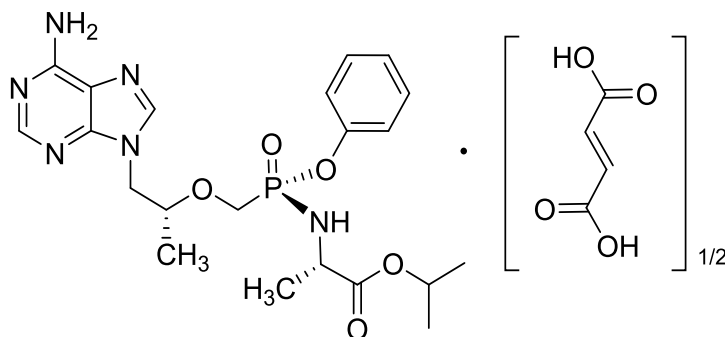

Physicochemical Properties:

Description: TAF hemifumarate is a white to off-white or tan powder.

Solubility: The solubility of TAF hemifumarate in water, pH 8.0 (50 mM phosphate buffer) at 20 °C is 4.86 mg/mL. The partition coefficient (log P) is 1.6 and the pKa is 3.96.

14 CLINICAL TRIALS

14.1 Study Demographics and Trial Design

Description of Clinical Studies

The efficacy and safety of GENVOYA in HIV-1 infected, treatment-naïve adults are based on 48-week data from two randomized, double-blind, active-controlled studies, Study 104 and Study 111 (N=1733). The efficacy and safety of GENVOYA in virologically suppressed HIV-1 infected adults are based on 48-week data from a randomized, open-label, active-controlled study, Study 109 (N=1436).

The efficacy and safety of GENVOYA in HIV-1 infected, virologically suppressed patients with mild to moderate renal impairment is based on 24-week data from an open-label study, Study 112 (N=242).

The efficacy and safety of GENVOYA in HIV-1 infected, virologically suppressed patients with end stage renal disease on chronic hemodialysis is based on 48-week data from a single arm, open-label study, Study 1825 (N=55).

The efficacy and safety of GENVOYA in HIV-1 infected, treatment-naïve pediatric patients between the ages of 12 to < 18 years (≥ 35 kg) is based on 24-week data from Cohort 1 of an open-label study, Study 106 (N=50).

The efficacy and safety of GENVOYA in virologically suppressed HIV-1 pediatric patients between the ages of 6 to < 12 years (≥ 25 kg) is based on 24-week from Cohort 2 of an open-label study, Study 106 (N=23).

Treatment Naïve HIV-1 Infected Patients

In both Study 104 and Study 111, patients were randomized in a 1:1 ratio to receive either GENVOYA (N = 866) once daily or STRIBILD (elvitegravir 150 mg/cobicistat 150 mg/emtricitabine 200 mg/tenofovir disoproxil fumarate 300 mg; N = 867) once daily.

In Studies 104 and 111, the mean age was 36 years (range 18-76), 85% were male, 57% were White, 25% were Black, and 10% were Asian. Nineteen percent of patients identified as Hispanic/Latino. The mean baseline plasma HIV-1 RNA was 4.5 log₁₀ copies per mL (range 1.3–7.0). The mean baseline CD4+ cell count was 427 cells /mm³ (range 0-1360) and 13% had CD4+ cell counts < 200 cells /mm³. Twenty-three percent of patients had baseline viral loads > 100,000 copies per mL.

For demographic and baseline characteristics for Study 104 and 111, see Table 13.

Table 13. Pooled Demographic and Baseline Characteristics of Antiretroviral Treatment-naïve HIV-1 Infected Adult Patients in Studies 104 and 111

	GENVOYA (N=866)	STRIBILD (N=867)
Demographic characteristics		
Median age, years (range)	33 (18-74)	35 (18-76)
Sex		
Male	733	740
Female	133	127
Race		
American Indian/ Alaska Native	5	8
White	485	498
Black	223	213
Native Hawaiian/ Pacific Islander	5	4
Asian	91	89
Other	57	55
Baseline disease characteristics		
Median baseline plasma HIV-1 RNA log ₁₀ copies/mL (range)	4.58 (2.57-6.89)	4.58 (1.28-6.98)
Percentage of patients with viral load ≤ 100,000 copies/mL	77.4	77.5
Percentage of patients with viral load > 100,000 to ≤ 400,000 copies/mL	17.0	17.8
Percentage of patients with viral load > 400,000 copies/mL	5.7	4.7
Median baseline CD4+ cell count /µL (range)	404 (0-1311)	406 (1-1360)
Percentage of patients with CD4+ cell counts < 200 cells/mm ³	13.0	13.5
HIV disease status		
Asymptomatic	779	800
Symptomatic HIV infection	53	34
AIDS	31	29
Unknown	3	4
Estimated CrCl by Cockcroft-Gault method (mL/min), median (Q1, Q3)	117.0 (99.6, 135.6)	113.9 (99.0, 133.6)
Proteinuria by urinalysis (dipstick)		
Grade 0	778	780
Grade 1	80	67
Grade 2	8	18
Grade 3	0	1
-Missing-	0	1

14.2 Study results

In both studies, patients were stratified by baseline HIV-1 RNA ($\leq 100,000$ copies per mL, $> 100,000$ copies per mL to $\leq 400,000$ copies per mL, or $> 400,000$ copies per mL), by CD4 count (< 50 cells per μL , 50-199 cells per μL , or ≥ 200 cells per μL), and by region (US or ex-US).

Treatment outcomes of Studies 104 and 111 through 48 and 144 weeks are presented in Table 14.

Table 14. Pooled Virologic Outcomes of Studies 104 and 111 at Weeks 48^a and 144^b

	Week 48		Week 144	
	GENVOYA (N=866)	STRIBILD (N=867)	GENVOYA (N=866)	STRIBILD (N=867)
Virologic Success HIV-1 RNA < 50 copies/mL	92%	90%	84%	80%
Treatment Difference	2.0% (95% CI: -0.7% to 4.7%)		4.2% (95% CI: 0.6% to 7.8%)	
Virologic Failure HIV-1 RNA ≥ 50 copies/mL ^c	4%	4%	5%	4%
No Virologic Data at Week 48 or Week 144 Window	4%	6%	11%	16%
Discontinued Study Drug Due to AE or Death ^d	1%	2%	1%	3%
Discontinued Study Drug Due to Other Reasons and Last Available HIV-1 RNA < 50 copies/mL ^e	2%	4%	9%	11%
Missing Data During Window but on Study Drug	1%	<1%	1%	1%
Proportion (%) of Patients with HIV-1 RNA < 50 copies/mL by Subgroup				
Age				
< 50 years	716/777 (92%)	680/753 (90%)	647/777 (83%)	602/753 (80%)
≥ 50 years	84/89 (94%)	104/114 (91%)	82/89 (92%)	92/114 (81%)
Sex				
Male	674/733 (92%)	673/740 (91%)	616/733 (84%)	603/740 (81%)
Female	126/133 (95%)	111/127 (87%)	113/133 (85%)	91/127 (72%)

GENVOYA (elvitegravir/cobicistat/emtricitabine/tenofovir alafenamide*) tablets
 *as tenofovir alafenamide hemifumarate
 Product Monograph

	Week 48		Week 144	
	GENVOYA (N=866)	STRIBILD (N=867)	GENVOYA (N=866)	STRIBILD (N=867)
Race				
Black	197/223 (88%)	177/213 (83%)	168/223 (75%)	152/213 (71%)
Nonblack	603/643 (94%)	607/654 (93%)	561/643 (87%)	542/654 (83%)
Baseline Viral Load				
≤ 100,000 copies/mL	629/670 (94%)	610/672 (91%)	567/670 (85%)	537/672 (80%)
> 100,000 copies/mL	171/196 (87%)	174/195 (89%)	162/196 (83%)	157/195 (81%)
Baseline CD4+ cell count				
< 200 cells /mm ³	96/112 (86%)	104/117 (89%)	93/112 (83%)	94/117 (80%)
≥ 200 cells /mm ³	703/753 (93%)	680/750 (91%)	635/753 (84%)	600/750 (80%)

- a. Week 48 window was between Day 294 and 377 (inclusive).
- b. Week 144 window was between Day 966 and 1049 (inclusive).
- c. Included patients who had ≥ 50 copies/mL in the Week 48 or 144 window; patients who discontinued early due to lack or loss of efficacy; patients who discontinued for reasons other than an adverse event (AE), death or lack or loss of efficacy and at the time of discontinuation had a viral value of ≥ 50 copies/mL.
- d. Includes patients who discontinued due to AE or death at any time point from Day 1 through the time window if this resulted in no virologic data on treatment during the specified window.
- e. Includes patients who discontinued for reasons other than an AE, death or lack or loss of efficacy; e.g., withdrew consent, loss to follow-up, etc.

GENVOYA met the noninferiority criteria in achieving HIV-1 RNA < 50 copies/mL at Week 48 and 96 when compared to STRIBILD. At Week 144, GENVOYA demonstrated statistical superiority ($p = 0.021$) in achieving HIV-1 RNA < 50 copies/mL when compared to STRIBILD. In Studies 104 and 111, the 95% CIs for differences in virologic success between treatment groups included zero for most subgroups evaluated suggesting no differences between the treatments.

In Studies 104 and 111, the mean increase from baseline in CD4+ cell count at Week 48, Week 96, and Week 144 was 230 cells/mm³, 280 cells /mm³, and 326 cells/mm³, respectively, in GENVOYA-treated patients, and 211 cells/mm³, 266 cells /mm³, and 305 cells/mm³, respectively, in STRIBILD treated patients ($p = 0.024$, $p = 0.14$, and $p = 0.06$ at Week 48, Week 96, and Week 144, respectively).

Bone Mineral Density

In the pooled analysis of Studies 104 and 111, the effects of GENVOYA compared to that of STRIBILD on bone mineral density (BMD) from baseline to Week 48, Week 96, and Week 144 were assessed by dual-energy X-ray absorptiometry (DXA). As shown in Table 15, in patients who had both baseline and Weeks 48, 96, and 144 measurements (Week 48: N = 780 and 784 in the GENVOYA group and N = 767 and 773 in the STRIBILD group, for hip and spine, respectively; Week 96: N = 716 and 722 in the GENVOYA group and N = 711 and 714 in the STRIBILD group for hip and spine, respectively; Week 144: N = 690 and 702 in the GENVOYA group and N = 683 and 686 in the STRIBILD group, for hip and spine, respectively) there were smaller decreases in BMD in the GENVOYA group as compared to STRIBILD.

Table 15. Measures of Bone Mineral Density in Studies 104 and 111 (Week 48, Week 96, and Week 144 Analyses)

	Week 48				Week 96				Week 144			
	GENVOYA	STRIBILD	Treatment Difference		GENVOYA	STRIBILD	Treatment Difference		GENVOYA	STRIBILD	Treatment Difference	
Hip DXA Analysis	N=780	N=767	Difference in LSM (95% CI)	P-value	N=716	N=711	Difference in LSM (95% CI)	P-value	N=690	N=683	Difference in LSM (95% CI)	P-value
Mean (SD) Percent Change in BMD	-0.7% (3.3%)	-3.0% (3.4%)	2.3% (2.0 to 2.6)	p < 0.001	-0.7% (3.9%)	-3.3% (4.0%)	2.6% (2.2 to 3.0)	p < 0.001	-0.8% (4.4%)	-3.4% (4.3%)	2.6% (2.2 to 3.1)	p < 0.001
Patients with Categorical Change:												
> 3% Decrease in BMD	17%	50%	--	--	23%	56%	--	--	28%	55%	--	--
> 3% Increase in BMD	7%	3%			12%	6%			13%	6%		
Patients with No Decrease (≥ zero % change) in BMD	35%	14%	--	--	39%	16%	--	--	40%	19%	--	--
Lumbar Spine DXA Analysis	N=784	N=773			N=722	N=714			N=702	N=686		
Mean (SD) Percent Change in BMD	-1.3% (3.1%)	-2.9% (3.2%)	1.6% (1.2 to 1.9)	p < 0.001	-1.0% (3.7%)	-2.8% (3.9%)	1.8% (1.4 to 2.2)	p < 0.001	-0.9% (4.1%)	-3.0% (4.3%)	2.0% (1.6 to 2.5)	p < 0.001
Patients with Categorical Change:												
> 3% Decrease in BMD	27%	46%	--	--	26%	48%	--	--	30%	49%	--	--
> 3% Increase in BMD	7%	3%			11%	6%			13%	7%		

GENVOYA (elvitegravir/cobicistat/emtricitabine/tenofovir alafenamide*) tablets
 *as tenofovir alafenamide hemifumarate
 Product Monograph

	Week 48				Week 96				Week 144			
	GENVOYA	STRIBILD	Treatment Difference		GENVOYA	STRIBILD	Treatment Difference		GENVOYA	STRIBILD	Treatment Difference	
Patients with No Decrease (\geq zero % change) in BMD	34%	17%	--	--	37%	21%	--	--	39%	22%	--	--

Changes in Renal Laboratory Tests and Renal Safety

Laboratory tests were performed in Studies 104 and 111 to compare the effect of TAF, administered as a component of GENVOYA, to that of tenofovir DF, administered as a component of STRIBILD, on renal laboratory parameters. As shown in Table 16, there were statistically significantly higher increases in serum creatinine, Urine Protein to Creatinine Ratio (UPCR), Urine Albumin to Creatinine Ratio (UACR), urine retinol binding protein (RBP) to creatinine ratio, and urine beta-2-microglobulin to creatinine ratio in the STRIBILD group as compared to the GENVOYA group. There were zero cases of Fanconi syndrome or Proximal Renal Tubulopathy (PRT) in the GENVOYA group through Week 144.

Table 16. Change from Baseline in Renal Laboratory Tests in Studies 104 and 111 (Week 48, Week 96, and Week 144 Analyses)

	Week 48			Week 96			Week 144		
	GENVOYA (N=866)	STRIBILD (N=867)	Treatment Difference	GENVOYA (N=866)	STRIBILD (N=867)	Treatment Difference	GENVOYA (N=866)	STRIBILD (N=867)	Treatment Difference
Serum Creatinine (µmol/L) ^a	7.07 ± 10.96	9.72 ± 19.18	-3.54 p < 0.001	3.54 ± 10.08	6.19 ± 11.23	-2.65 p < 0.001	3.54 ± 10.61	6.19 ± 11.23	-3.54 p < 0.001
Proteinuria by Urine Dipstick ^b	31%	37%	p = 0.022	36%	41%	p = 0.034	40%	45%	p = 0.027
Urine Protein to Creatinine Ratio [UPCR] ^c	-3.4%	19.8%	p < 0.001	-9.1%	16.2%	p < 0.001	-10.5%	25.2%	p < 0.001
Urine Albumin to Creatinine Ratio [UACR] ^{c,d}	-4.7%	7.1%	p < 0.001	-5.2%	4.9%	p < 0.001	- ^d	- ^d	- ^d
Urine RBP to Creatinine Ratio ^c	9.2%	51.2%	p < 0.001	13.8%	74.2%	p < 0.001	34.8%	111%	p < 0.001
Urine Beta-2-Microglobulin to Creatinine Ratio ^c	-31.7%	24.1%	p < 0.001	-32.1%	33.5%	p < 0.001	-25.7%	53.8%	p < 0.001

- a. Mean change ± SD
- b. Includes all severity grades (1-3).
- c. Median percent change.
- d. UACR was assessed up to Week 96..

At Weeks 48, 96, and 144, the proportion of patients with any grade hypophosphatemia in GENVOYA was 3.6%, 5.6%, and 6.8%, respectively, and 4.0%, 5.4%, and 7.6%, respectively, in STRIBILD. The median (Q1, Q3) change from baseline in FEPO_4 was 2.0% (-1.2%, 5.6%), 2.1% (-1.3%, 5.5%), and 3.0% (-0.7%, 7.2%) at Weeks 48, 96, and 144, respectively, in patients receiving GENVOYA, and 2.6% (-0.7%, 6.4%), 2.7% (-0.8%, 7.0%), and 4.1% (0.2%, 8.0%) at Weeks 48, 96, and 144, respectively, in patients receiving STRIBILD ($p = 0.006, 0.009, \text{ and } 0.001$, at Weeks 48, 96, and 144, respectively).

The median (Q1, Q3) change from baseline in the ratio of the renal tubular maximum reabsorption rate of phosphate to the glomerular filtration rate (TmP/GFR) was -0.2 (-0.7 mg/dL, 0.2 mg/dL), -0.3 mg/dL (-0.9 mg/dL, 0.2 mg/dL), and -0.4 mg/dL (-1.0 mg/dL, 0.1 mg/dL) at Weeks 48, 96, and 144, respectively, in patients receiving GENVOYA, and -0.3 (-0.7 mg/dL, 0.2 mg/dL), -0.4 mg/dL (-0.8 mg/dL, 0.1 mg/dL), and -0.5 mg/dL (-1.0 mg/dL, 1.0 mg/dL) at Weeks 48, 96, and 144, respectively, in patients receiving STRIBILD ($p = 0.21, 0.35, \text{ and } 0.011$ at Weeks 48, 96, and 144, respectively).

Changes in Lipid Laboratory Tests

Increases from baseline were observed in both treatment groups for the fasting lipid parameters total cholesterol, direct LDL, HDL, and triglycerides at Weeks 48, 96, and 144. The median increase from baseline for these parameters was greater in the GENVOYA group compared with the STRIBILD group ($p < 0.001$ for the difference between treatment groups for fasting total cholesterol, direct LDL, HDL, and triglycerides). Median (Q1, Q3) change from baseline at Weeks 48, 96, and 144 in total cholesterol to HDL ratio was 0.1 (-0.3, 0.5), 0.1 (-0.3, 0.7), and 0.2 (-0.3, 0.7), respectively, in the GENVOYA group and 0.0 (-0.5, 0.4), 0.0 (-0.4, 0.5), and 0.1 (-0.4, 0.6), respectively, in the STRIBILD group ($p < 0.001$ for the difference between treatment groups at Weeks 48 and 96; $p = 0.006$ at Week 144).

In Virologically Suppressed HIV-1 Infected Patients

In Study 109, the efficacy and safety of switching from either ATRIPLA (efavirenz/emtricitabine/tenofovir disoproxil fumarate [EFV/FTC/TDF]), TRUVADA (emtricitabine/tenofovir disoproxil fumarate [FTC/TDF]) plus atazanavir (boosted by either cobicistat or ritonavir), or STRIBILD to GENVOYA were evaluated in a randomized, open-label study of virologically suppressed (HIV-1 RNA < 50 copies/mL) HIV-1 infected adults ($N = 1436$). Patients must have been stably suppressed (HIV-1 RNA < 50 copies/mL) on their baseline regimen for at least 6 months and had no resistance mutations to any of the components of GENVOYA prior to study entry. Patients were randomized in a 2:1 ratio to either switch to GENVOYA at baseline ($N = 959$), or stay on their baseline antiretroviral regimen ($N = 477$). Patients had a mean age of 41 years (range 21-77), 89% were male, 67% were White, and 19% were Black. The mean baseline CD4+ cell count was 697 cells / mm^3 (range 79-1951). Demographic and baseline characteristics are presented in Table 17.

Patients were stratified by prior treatment regimen. At screening, 42% of patients were receiving TRUVADA plus atazanavir (boosted by either cobicistat or ritonavir), 32% of patients were receiving STRIBILD, and 26% of patients were receiving ATRIPLA.

Table 17. Demographic and Baseline Characteristics of Virologically Suppressed HIV-1 Infected Adult Patients in Study 109

	Study 109	
	GENVOYA (N= 959)	Baseline Regimen (N= 477)
Demographic characteristics		
Median age, years (range)	41 (21-77)	40 (22-69)
Sex		
Male	856	427
Female	103	50
Race		
American Indian/ Alaska Native	5	2
White	651	314
Black	169	102
Native Hawaiian/ Pacific Islander	6	1
Asian	59	35
Other	67	22
Not permitted	2	1
Prior treatment regimen		
STB	306	153
ATR	251	125
ATV/boosted+TVD	402	199
Baseline disease characteristics		
HIV-1 RNA < 50 copies/mL	943	466
CD4 cell count (cells/ μ L), median (Q1, Q3)	675 (520, 833)	662 (525, 831)
Estimated CrCl by Cockcroft-Gault method (mL/min), median (Q1, Q3)	105.7 (89.4, 126.0)	107.7 (88.7, 128.2)
Proteinuria by urinalysis (dipstick)		
Grade 0	873	430
Grade 1	81	44
Grade 2	4	3
Grade 3	0	0
-Missing-	1	0

STB: STRIBILD; ATR: ATRIPLA; ATV: atazanavir; TVD: TRUVADA

Study results

Treatment outcomes of Study 109 through 48 and 96 weeks are presented in Table 18.

Table 18. Virologic Outcomes of Study 109 at Weeks 48^a and 96^b

	Week 48		Week 96	
	GENVOYA (N=959)	Baseline Regimen (N=477)	GENVOYA (N=959)	Baseline Regimen (N=477)
Virologic Success HIV-1 RNA < 50 copies/mL	97%	93%	93%	89%
Treatment Difference	4.1% (95% CI: 1.6% to 6.7%)		3.7% (95% CI: 0.4% to 7.0%)	
p-value	p < 0.001		p = 0.017	
Virologic Failure HIV-1 RNA ≥ 50 copies/mL^c	1%	1%	2%	2%
No Virologic Data at Week 48 Window	2%	6%	5%	9%
Discontinued Study Drug Due to AE or Death ^d	1%	1%	1%	3%
Discontinued Study Drug Due to Other Reasons and Last Available HIV-1 RNA < 50 copies/mL ^e	1%	4%	3%	6%
Missing Data During Window but on Study Drug	0	≤1%	1%	<1%

- a. Week 48 window was between Day 294 and 377 (inclusive).
 b. Week 96 window was between Day 630 and 713 (inclusive).
 c. Included patients who had ≥ 50 copies/mL in the Week 48 or Week 96 window; patients who discontinued early due to lack or loss of efficacy; patients who discontinued for reasons other than an adverse event (AE), death or lack or loss of efficacy and at the time of discontinuation had a viral value of ≥ 50 copies/mL.
 d. Includes patients who discontinued due to AE or death at any time point from Day 1 through the time window if this resulted in no virologic data on treatment during the specified window.
 e. Includes patients who discontinued for reasons other than an AE, death or lack or loss of efficacy; e.g., withdrew consent, loss to follow-up, etc.

Switching to GENVOYA was superior at Week 48 (p < 0.001) and at Week 96 (p = 0.017) in maintaining HIV-1 RNA < 50 copies/mL when compared to patients who stayed on their baseline regimen.

The mean increase from baseline in CD4+ cell count at Week 48 and Week 96 was 35 cells/mm³ and 60 cells /mm³ in GENVOYA-treated patients, respectively, and 24 cells/mm³ and 42 cells /mm³ in patients who stayed on their baseline regimen, respectively.

Bone Mineral Density: Changes in BMD from baseline to Week 48 were assessed by DXA in patients who had both baseline and Week 48 measurements (N=869 and N=881 in the GENVOYA arm, and N=428 and N=436 in patients who remained on their baseline regimen, for hip and spine, respectively). Changes in BMD from baseline to Week 96 were assessed by DXA in patients who had both baseline and Week 96 measurements (N= 809 and N= 821 in the GENVOYA arm, and N= 396 and N= 401 in

patients who remained on their baseline regimen, for hip and spine, respectively). Results for Weeks 48 and 96 are summarized in Table 19.

At Week 96, the mean (SD) change from baseline was 2.4% (3.6) and 2.1% (3.8) in the GENVOYA group and -0.5% (3.4) and -0.1% (3.5) in the FTC/TDF+3rd agent baseline regimen group, in hip and spine BMD, respectively ($p < 0.001$ for the differences between groups at Week 96).

Table 19. Measures of Bone Mineral Density in Study 109 (Week 48 and Week 96 Analyses)

	Week 48				Week 96			
	GENVOYA	Baseline Regimen	Treatment Difference		GENVOYA	Baseline Regimen	Treatment Difference	
Hip DXA Analysis	N=869	N=428	Difference in LSM (95% CI)	P-value	N=809	N=396	Difference in LSM (95% CI)	P-value
Mean (SD) Percent Change in BMD	1.5% (2.7%)	-0.3% (2.8%)	1.8% (1.5 to 2.1)	p < 0.001	2.4% (3.6%)	-0.5% (3.4%)	2.9% (2.5 to 3.3)	p < 0.001
Patients with Categorical Change: > 3% Decrease in BMD > 3% Increase in BMD	3% 21%	13% 7%	--		2% 35%	15% 9%	--	
Patients with No Decrease (≥ zero % change) in BMD	78%	46%	--		82%	43%	--	
Lumbar Spine DXA Analysis	N=881	N=436			N=821	N=401		
Mean (SD) Percent Change in BMD	1.6% (3.8%)	-0.4% (4.1%)	2.0% (1.5 to 2.4)	p < 0.001	2.1% (3.8%)	-0.1% (3.5%)	2.2% (1.8 to 2.6)	p < 0.001
Patients with Categorical Change: > 3% Decrease in BMD > 3% Increase in BMD	8% 33%	19% 13%	--		6% 37%	17% 18%	--	
Patients with No Decrease (≥ zero % change) in BMD	74%	47%	--		75%	47%	--	

Changes in Renal Laboratory Tests and Renal Safety

There were decreases from baseline in proteinuria (UPCR), albuminuria (UACR), and tubular proteinuria (urine RBP to creatinine ratio and urine beta-2-microglobulin to creatinine ratio), and also in other measures of proximal renal tubular dysfunction (including fractional excretion of uric acid [FEUA]) in patients receiving GENVOYA, as compared with increases from baseline in patients who stayed on their TDF-containing baseline regimen, collectively indicating a reduced impact of TAF on proximal renal tubular function. At Week 96, the median percentage change in UPCR was -26% vs. 9%; in UACR it was -14% vs. 11%. At Week 48, the median percentage change in urine RBP to creatinine ratio was -33% vs. 18%; and in urine beta-2-microglobulin to creatinine ratio it was -52% vs. 19%. P-value was < 0.001 for all comparisons. There were zero cases of Fanconi syndrome or PRT in patients switching to GENVOYA through Week 96.

HIV-1 Infected Patients with Renal Impairment

Study 112: Virologically-suppressed adults with renal impairment

In Study 112, the efficacy and safety of GENVOYA were evaluated in an open-label clinical study in which 242 HIV-1 infected patients with mild to moderate renal impairment (estimated CrCl by Cockcroft-Gault method between 30 to 69 mL/minute) switched to GENVOYA as shown in Table 20. Patients were virologically suppressed (HIV-1 RNA < 50 copies/mL) for at least 6 months before switching to GENVOYA.

The mean age was 58 years (range 24-82), with 63 patients (26%) who were ≥ 65 years of age. Seventy-nine percent were male, 63% were White, 18% were Black, and 14% were Asian. Thirteen percent of patients identified as Hispanic/Latino. At baseline, median estimated CrCl was 56 mL/minute, and 33% of patients had an estimated CrCl from 30 to 49 mL/minute. The mean baseline CD4+ cell count was 664 cells /mm³ (range 126-1813). At Week 24, 95.0% (230/242 patients) maintained HIV-1 RNA < 50 copies/mL after switching to GENVOYA. Three patients had virologic failure at Week 24. At Week 96, 88.4% (214/242) of patients maintained HIV-1 RNA < 50 copies/mL after switching to GENVOYA. At Week 144, 83.1% (197/237) maintained HIV-1 RNA < 50 copies/mL after switching to GENVOYA; 14.8% of patients had no virologic data in the Week 144 window. Five patients among the entire study population had virologic failure at Week 144.

Table 20. Demographic and Baseline Characteristics of Virologically Suppressed HIV-1 Infected Adult Patients in Study 112

	Study 112	
	Cohort 1: ART-Experienced	
	Baseline estimated CrCl by Cockcroft-Gault method < 50 mL/min (N = 80)	Baseline estimated CrCl by Cockcroft-Gault method ≥ 50 mL/min (N = 162)
Demographic characteristics		
Median age, years (range)	59 (31-82)	58 (24-76)
Sex		
Male	59	133
Female	21	29
Race		
American Indian/ Alaska Native	1	0
White	39	113
Black	14	30
Native Hawaiian/ Pacific Islander	0	2
Asian	23	11
Other	3	4
Not permitted	0	2
Baseline disease characteristics		
HIV-1 RNA categories (copies/mL)		
< 50	78	158
≥ 50 to ≤ 100,000	2	4
> 100,000 to ≤ 400,000	0	0
CD4 cell count (cells/uL), median (Q1, Q3)	622 (449, 844)	635 (461, 797)
HIV disease status		
Asymptomatic	46	134
Symptomatic HIV infection	18	10
AIDS	16	18
Estimated CrCl by Cockcroft-Gault method ^b (mL/min), median (Q1, Q3)	42.6 (37.7, 45.7)	60.3 (55.5, 65.0)
Proteinuria by urinalysis (dipstick)		
Grade 0	45	118
Grade 1	23	33
Grade 2	12	11
Grade 3	0	0

In a substudy, patients given GENVOYA (N=32) had no change from baseline in their actual glomerular filtration rate at Week 24, as measured by iohexol clearance.

Study 1825: Virologically-suppressed adults with end stage renal disease (ESRD) receiving chronic hemodialysis

In Study 1825, the efficacy and safety of GENVOYA were evaluated in a single arm, open-label clinical study in which 55 HIV-1 infected adults with end stage renal disease (estimated CrCl by Cockcroft-Gault method < 15 mL/min) receiving chronic hemodialysis for at least 6 months switched to GENVOYA. Patients were virologically suppressed (HIV-1 RNA < 50 copies/mL) for at least 6 months before switching to GENVOYA.

The mean age was 48 years (range 23-64). Seventy-six percent were male, 82% were Black and 18% were White. Fifteen percent of patients identified as Hispanic/Latino. The mean baseline CD4+ cell count was 545 cells/mm³ (range 205-1473).

Study results

Study 112: Virologically-suppressed adults with renal impairment

Changes from baseline in renal laboratory tests at Weeks 24, 96, and 144 in patients who switched to GENVOYA are presented in Table 21. The prevalence of clinically significant proteinuria (UPCR > 200 mg/g) was 42% at baseline, and decreased to 21%, 18%, and 16% at Weeks 24, 96, and 144, respectively. The prevalence of clinically significant albuminuria (UACR ≥ 30 mg/g) was 49% at baseline, and decreased to 27%, 27%, and 32% at Weeks 24, 96, and 144, respectively. Other renal assessments, including fractional excretion of uric acid, serum cystatin C, and serum phosphorus showed small changes from baseline at each time point through Weeks 24, 96, and 144. Overall, multiple assessments of renal function indicate that changes in renal function were observed as soon as 1 week after switching to GENVOYA and persisted through 144 weeks.

Table 21. Change from Baseline in Renal Laboratory Tests at Week 24, Week 96, and Week 144 in Virologically Suppressed Patients with Renal Impairment who Switched to GENVOYA in Study 112 (Week 24, Week 96, and Week 144 Analyses)

	Week 24	Week 96	Week 144
	GENVOYA (N=242)		
Serum Creatinine (µmol/L) ^a	1.77 ± 22.19	-2.65 ± 24.66	-4.42 ± 25.38
Improvement in Proteinuria by Urine Dipstick ^b	57/76 (75%)	60/71 (85%)	56/66 (85%)
Urine Protein to Creatinine Ratio [UPCR] ^c	-35.3%	-37.7%	-45.7%
Urine Albumin to Creatinine Ratio [UACR] ^c	-38.8%	-45.5%	-35.1%
Urine RBP to Creatinine Ratio ^c	-56.2%	-64.1%	-63.8%

	Week 24	Week 96	Week 144
	GENVOYA (N=242)		
Urine Beta-2-Microglobulin to Creatinine Ratio ^c	-70.7%	-83.6%	-81.9%

- a. Mean change \pm SD.
- b. An improvement of at least 1 toxicity grade from baseline.
- c. Median percent change.

Bone Mineral Density: In virologically suppressed patients with renal impairment who switched to GENVOYA, mean percentage increases from baseline at Weeks 24, 96, and 144 were observed in hip and spine BMD. At Week 144, assessment of BMD using a threshold of 3% for changes from baseline revealed higher percentages of patients had increases versus decreases from baseline in BMD at both hip (38.4% versus 9.0%) and spine (47.4% versus 10.3%).

At Week 144, the mean (SD) percentage BMD increase from baseline was 3.2% (4.9) at the hip and 3.6% (5.2) at the spine for patients who switched to GENVOYA from a TDF-based regimen.

The median (Q1, Q3) percentage increases from baseline in hip and spine BMD were higher in virologically suppressed patients who switched to GENVOYA from a TDF-based regimen (hip: 2.3% [0.4%, 4.8%], spine: 3.7% [0.7%, 6.0%]) than in those patients who switched to GENVOYA from a non-TDF-based regimen (hip: 1.0% [-1.5%, 3.3%], spine: 0.6% [-1.6%, 4.1%]). The percentage changes (increases) from baseline in hip and spine BMD were statistically significant at each time point through Week 144 for virologically suppressed patients who switched to GENVOYA from a TDF-based regimen ($p < 0.001$).

Study 1825: Virologically-suppressed adults with end stage renal disease (ESRD) receiving chronic hemodialysis

At Week 48, 81.8% (45/55 patients) maintained HIV-1 RNA < 50 copies/mL after switching to GENVOYA. Two patients had HIV-1 RNA ≥ 50 copies/mL by Week 48. Seven patients discontinued the study drug due to AE or other reasons while suppressed. One patient did not have an HIV-1 RNA measurement at Week 48. There were no clinically significant changes in fasting lipid laboratory tests in patients who switched to GENVOYA.

Pediatric Patients

In Study 106, the efficacy, safety, and pharmacokinetics of GENVOYA in HIV-1 infected patients were evaluated in an open-label study in HIV-1-infected treatment-naïve adolescents between the ages of 12 to < 18 years (≥ 35 kg) (N=50) through Week 48 and in virologically suppressed pediatric patients between the ages of 6 to < 12 years (≥ 25 kg) (N=23) through Week 24.

Cohort 1: Treatment-Naïve Adolescents (12 to < 18 Years of Age and Weighing ≥ 35 kg)

Patients in Cohort 1 had a mean age of 15 years (range: 12 to 17), 44% were male, 12% were Asian, and 88% were black. At baseline, mean plasma HIV-1 RNA was 4.6 log₁₀ copies/mL, median CD4+ cell count was 456 cells/mm³ (range: 95 to 1110), and median CD4+% was 23% (range: 7% to 45%). Twenty-two percent had baseline plasma HIV-1 RNA > 100,000 copies/mL as shown in Table 22.

Table 22. Demographic and Baseline Characteristics of Treatment-naïve HIV-1 Infected Adolescent Patients in Study 106 (Cohort 1)

	Study 106 (Cohort 1)
	GENVOYA (N= 50)
Demographic characteristics	
Median age, years (range)	15 (12-17)
Sex	
Male	22
Female	28
Race	
Asian	6
Black	44
Baseline BMI (kg/m ²), median (Q1, Q3)	20.0 (18.1, 23.1)
Baseline disease characteristics	
HIV-1 RNA (log ₁₀ copies/mL), median (Q1, Q3)	4.65 (4.25, 4.94)
HIV-1 RNA > 100,000 copies/mL	11
CD4 cell count (cells/μL), median (Q1, Q3)	456 (332, 574)
Mode of infection (HIV risk factors)	
Heterosexual sex	12
Homosexual sex	8
IV drug use	1
Vertical transmission	32
HIV disease status	
Asymptomatic	42
Symptomatic HIV infection	8
Estimated CrCl by Schwartz formula (mL/min/1.73 m ²), median (Q1, Q3)	156 (129.0, 185.0)
Proteinuria by urinalysis (dipstick), n (%)	
Grade 0	48
Grade 1	1
Grade 2	1
Grade 3	0

Cohort 2: Virologically Suppressed Children (6 to < 12 Years of Age and Weighing ≥ 25 kg)

Patients in Cohort 2 had a mean age of 10 years (range: 8 to 11), a mean baseline weight of 31.6 kg (range: 26 to 58), 39% were male, 13% were Asian, and 78% were black. At baseline, median CD4+ cell count was 969 cells/mm³ (range: 603 to 1421), and median CD4+% was 39% (range: 30% to 51%). All 23 patients had baseline plasma HIV-1 RNA < 50 copies/mL as shown in Table 23.

Table 23. Demographic and Baseline Characteristics of Virologically Suppressed Patients in Study 106 (Cohort 2)

	Study 106 (Cohort 2)
	GENVOYA (N= 23)
Demographic characteristics	
Median age, years (range)	10 (8-11)
Sex	
Male	9
Female	14
Race	
Asian	3
Black	18
White	2
Baseline BMI (kg/m ²), median (Q1, Q3)	15.9 (15.2, 18.1)
Baseline disease characteristics	
HIV-1 RNA < 50 copies/mL	23
CD4 cell count (cells/μL), median (Q1, Q3)	969 (843, 1087)
Mode of infection (HIV risk factors)	
Vertical transmission	23
HIV disease status	
Asymptomatic	23
Estimated CrCl by Schwartz formula (mL/min/1.73 m ²), median (Q1, Q3)	150.0 (134.7, 165.6)
Proteinuria by urinalysis (dipstick), n (%)	
Grade 0	22
Grade 1	1
Grade 2	0
Grade 3	0

Study results

Cohort 1: Treatment-naïve Adolescents (≥ 12 to < 18 Years of Age and Weighing ≥ 35 kg)

At Week 24, out of 23 patients assessed for efficacy, 91% of patients treated with GENVOYA achieved HIV-1 RNA < 50 copies/mL. At Week 48, 92% (46/50) of patients treated with GENVOYA achieved HIV-1 RNA < 50 copies/mL. The mean increase from baseline in CD4+ cell count at Weeks 24 and 48 was 212 cells/mm³ and 224 cells /mm³, respectively. Two patients had virologic failure by snapshot at Week 24 and three of the 50 patients had virologic failure by snapshot at Week 48; no emergent resistance to GENVOYA was detected through Weeks 24 and 48.

Fifty patients in Cohort 1 were assessed for safety at Weeks 24 and 48 (these patients received GENVOYA for 24 and 48 weeks). BMD by DXA was assessed in 47 patients for spine at both Week 24 and Week 48. BMD by DXA was assessed in 45 and 44 patients for total body less head (TBLH) at Week 24 and Week 48, respectively. Mean (SD) BMD increased from baseline to Week 24, +1.6% (3.9%) at the lumbar spine and +0.6 % (2.5%) for TBLH. Mean (SD) BMD increased from baseline to Week 48, +4.2% (5.0%) at the lumbar spine and +1.3% (2.7%) for TBLH.

Cohort 2: Virologically Suppressed Children (6 to < 12 Years of Age and Weighing ≥ 25 kg)

At Week 24, 100% (23/23) of patients in Cohort 2 remained suppressed (HIV-1 RNA < 50 copies/mL) after switching to GENVOYA. The mean change from baseline in CD4+ cell count at Week 24 was -150 cells/mm³. No emergent resistance to GENVOYA was detected through Week 24.

Among the patients in Cohort 2 who had both baseline and Week 24 measurements, BMD by DXA was assessed in 21 patients for spine and 23 patients for TBLH. Mean (SD) BMD increased from baseline to Week 24, +2.9% (4.9%) at the lumbar spine and +1.7% (2.5%) for TBLH.

15 MICROBIOLOGY

Antiviral Activity

Elvitegravir, Cobicistat, Emtricitabine, and Tenofovir Alafenamide: When tested, elvitegravir, emtricitabine, and tenofovir alafenamide demonstrated synergistic antiviral activity in cell culture. Antiviral synergy was maintained for elvitegravir, emtricitabine, and tenofovir alafenamide when tested in the presence of cobicistat.

Elvitegravir. The antiviral activity of elvitegravir against laboratory and clinical isolates of HIV-1 was assessed in T lymphoblastoid cell lines, monocyte/macrophage cells, and primary peripheral blood lymphocytes. The 50% effective concentrations (EC₅₀) ranged

from 0.02 to 1.7 nM. Elvitegravir displayed antiviral activity in cell culture against HIV-1 clades A, B, C, D, E, F, G, and O (EC₅₀ values ranged from 0.1 to 1.3 nM) and activity against HIV-2 (EC₅₀ value of 0.53 nM). Elvitegravir did not show inhibition of replication of HBV or HCV in cell culture.

Cobicistat: Cobicistat has no detectable antiviral activity in cell culture against HIV-1, HBV, or HCV and does not antagonize the antiviral activity of elvitegravir, emtricitabine, or tenofovir.

Emtricitabine: The antiviral activity of emtricitabine against laboratory and clinical isolates of HIV-1 was assessed in T lymphoblastoid cell lines, the MAGI-CCR5 cell line, and primary peripheral blood mononuclear cells. The EC₅₀ values for emtricitabine were in the range of 0.0013–0.64 µM. Emtricitabine displayed antiviral activity in cell culture against HIV-1 clades A, B, C, D, E, F, and G (EC₅₀ values ranged from 0.007–0.075 µM) and showed strain specific activity against HIV-2 (EC₅₀ values ranged from 0.007–1.5 µM).

Tenofovir Alafenamide: The antiviral activity of tenofovir alafenamide against laboratory and clinical isolates of HIV-1 subtype B was assessed in lymphoblastoid cell lines, PBMCs, primary monocyte/macrophage cells and CD4-T lymphocytes. The EC₅₀ values for tenofovir alafenamide were in the range of 2.0 to 14.7 nM.

Tenofovir alafenamide displayed antiviral activity in cell culture against all HIV-1 groups (M, N, O), including sub-types A, B, C, D, E, F, and G (EC₅₀ values ranged from 0.10 to 12.0 nM) and strain specific activity against HIV-2 (EC₅₀ values ranged from 0.91 to 2.63 nM).

In a study of tenofovir alafenamide with a broad panel of representatives from the major classes of approved anti-HIV agents (NRTIs, NNRTIs, INSTIs, and PIs), additive to synergistic effects were observed. No antagonism was observed for these combinations.

Resistance

In Cell Culture

Elvitegravir: HIV-1 isolates with reduced susceptibility to elvitegravir have been selected in cell culture. Reduced susceptibility to elvitegravir was associated with the primary integrase substitutions T66A/I, E92G/Q, S147G, and Q148R. Additional integrase substitutions observed in cell culture selection included D10E, S17N, H51Y, F121Y, S153F/Y, E157Q, D232N, R263K, and V281M.

Emtricitabine: HIV-1 isolates with reduced susceptibility to emtricitabine have been selected in cell culture. Reduced susceptibility to emtricitabine was associated with M184V/I substitutions in HIV-1 RT.

Tenofovir Alafenamide: HIV-1 isolates with reduced susceptibility to tenofovir alafenamide have been selected in cell culture. HIV-1 isolates selected by tenofovir alafenamide expressed a K65R substitution in HIV-1 RT; in addition, a K70E substitution in HIV-1 RT has been transiently observed. HIV-1 isolates with the K65R substitution have reduced susceptibility to abacavir, emtricitabine, tenofovir alafenamide, tenofovir, and lamivudine. *In vitro* drug resistance selection studies with tenofovir alafenamide have shown no development of resistance increases above 2.5-fold after 6 months in culture.

In Clinical Trials

In Treatment-Naïve Patients: In a pooled analysis of antiretroviral-naïve patients receiving GENVOYA in Phase 3 Studies 104 and 111, genotyping was performed on plasma HIV-1 isolates from all patients with HIV-1 RNA \geq 400 copies/mL at confirmed virologic failure, at Week 144, or at time of early study drug discontinuation. As of Week 144, the development of one or more primary elvitegravir, emtricitabine, or tenofovir alafenamide resistance-associated mutations was observed in 12 of 22 patients with evaluable genotypic data from paired baseline and GENVOYA treatment-failure isolates (12 of 866 patients [1.4%]) compared with 12 of 20 treatment-failure isolates from patients with evaluable genotypic data in the STRIBILD treatment group (12 of 867 patients [1.4%]). Of the 12 patients with resistance development in the GENVOYA group, the mutations that emerged were M184V/I (N = 11) and K65R/N (N = 2) in reverse transcriptase and T66T/A/I/V (N = 2), E92Q (N = 4), Q148Q/R (N = 1) and N155H (N = 2) in integrase. Of the 12 patients with resistance development in the STRIBILD group, the mutations that emerged were M184V/I (N = 9), K65R/N (N = 4), and L210L/W (N = 1) in reverse transcriptase and E92Q/V (N = 4), Q148R (N = 2), and N155H/S (N = 3) in integrase. In both treatment groups, most patients who developed resistance mutations to elvitegravir developed resistance mutations to both emtricitabine and elvitegravir.

In phenotypic analyses of patients in the final resistance analysis population, 7 of 22 patients (32%) had HIV-1 isolates with reduced susceptibility to elvitegravir in the GENVOYA group compared with 7 of 20 patients (35%) in the STRIBILD group, 8 patients (36%) had reduced susceptibility to emtricitabine in the GENVOYA group compared with 7 patients (35%) in the STRIBILD group. One patient in the GENVOYA group (1 of 22 [4.5%]) and 2 patients in the STRIBILD group (2 of 20 [10%]) had reduced susceptibility to tenofovir.

In Virologically Suppressed Patients: Three patients with emergent resistance to GENVOYA were identified (M184M/I; M184I + E92G; M184V + E92Q) as of Week 96 in a clinical study of virologically suppressed patients who switched from a regimen containing emtricitabine/tenofovir disoproxil fumarate and a third agent (Study 109, N = 959).

Cross Resistance

In HIV-1 Infected Treatment-Naïve Patients or Virologically Suppressed Patients: No cross-resistance has been demonstrated for elvitegravir-resistant HIV-1 isolates and emtricitabine or tenofovir, or for emtricitabine- or tenofovir-resistant isolates and elvitegravir.

Elvitegravir: Cross-resistance has been observed among INSTIs. Elvitegravir-resistant viruses showed varying degrees of cross-resistance in cell culture to raltegravir depending on the type and number of substitutions in HIV-1 integrase. Of the primary elvitegravir resistance-associated substitutions tested (T66A/I/K, E92G/Q, T97A, S147G, Q148H/K/R, and N155H), all but three (T66I, E92G, and S147G) conferred greater than 1.5-fold reduced susceptibility to raltegravir (above the biological cutoff for raltegravir) when introduced individually into a wild-type virus by site-directed mutagenesis. Of the primary raltegravir resistance-associated substitutions (Y143C/H/R, Q148H/K/R, and N155H), all but Y143C/H conferred greater than 2.5-fold reductions in susceptibility to elvitegravir (above the biological cutoff for elvitegravir). Viruses expressing elvitegravir or raltegravir resistance mutations maintain susceptibility to dolutegravir.

Emtricitabine: Cross-resistance has been observed among NRTIs. Emtricitabine-resistant isolates harboring an M184V/I substitution in HIV-1 RT were cross-resistant to lamivudine. HIV-1 isolates containing the K65R RT substitution, selected *in vivo* by abacavir, didanosine, and tenofovir, demonstrated reduced susceptibility to inhibition by emtricitabine.

Tenofovir Alafenamide: The K65R and K70E mutations result in reduced susceptibility to abacavir, didanosine, lamivudine, emtricitabine, and tenofovir, but retain sensitivity to zidovudine.

Multinucleoside resistant HIV-1 with a T69S double insertion mutation or with a Q151M mutation complex including K65R showed reduced susceptibility to tenofovir alafenamide.

HIV-1 containing the K103N or Y181C mutations associated with resistance to NNRTIs were susceptible to tenofovir alafenamide.

HIV-1 containing mutations associated with resistance to PIs, such as M46I, I54V, V82F/T, and L90M were susceptible to tenofovir alafenamide.

16 NON-CLINICAL TOXICOLOGY

General

No toxicology studies have been conducted with GENVOYA tablets. The toxicology information is based on studies conducted with elvitegravir, cobicistat, emtricitabine or tenofovir alafenamide as individual agents.

Elvitegravir: The nonclinical safety profile of elvitegravir has been studied in mice, rats, rabbits and dogs. Elvitegravir has demonstrated minimal acute toxicity after oral dosing to rats and dogs (lethal dose > 2000 mg/kg and > 1000 mg/kg in rats and dogs, respectively). There were no significant adverse effects in mice treated for 13 weeks at doses up to 2000 mg/kg/day. No adverse target organ toxicity has been observed in studies up to 26 weeks in rats and 39 weeks in dogs at dose levels up to 2000 mg/kg/day and 100 mg/kg/day, respectively. Two nonadverse findings, not considered clinically relevant, were observed in rats and dogs. Lipid-like vacuoles were observed in the lamina propria, mainly in the upper small intestine (duodenum and/or jejunum) in rats and dogs, but there were no toxic or reactive changes associated with these vacuoles. Increased cecal weight and dilatation with whitish loose contents in rats were not accompanied by histopathologic changes or adverse clinical observations. The NOAELs for elvitegravir are considered to be 2000 mg/kg/day for mice and rats, and 100 mg/kg/day for dogs – the highest doses evaluated in the 13-week, 26-week, and 39-week repeat-dose studies, respectively.

Cobicistat: The nonclinical safety profile of cobicistat has been studied in mice, rats, rabbits and dogs. The single dose toxicity of COBI was low; the maximum tolerated dose was 100 mg/kg in mice; no adverse effects were noted in rats at 500 mg/kg. In repeat-dose studies (up to 13 weeks in mice, up to 26 weeks in rats; up to 39 weeks in dogs), target organs identified were liver (mouse, rat, and dog) and thyroid (rat). The liver effects in mice and rats are considered adaptive changes, are commonly seen in rodents with microsomal enzyme inducers, and are considered secondary to microsomal enzyme induction. In dogs, hepatic changes were considered an adaptive response, and not adverse based on their minimal severity, the absence of degeneration, and their reversibility after cessation of dosing. The thyroid changes in rats are considered adaptive changes, secondary to hepatic microsomal enzyme induction and thyroid hormone imbalance. The thyroid effects are considered rodent specific and predispose rats, but not humans, to thyroid neoplasms. The NOAELs for cobicistat are considered to be 5 (males) and 50 (females) mg/kg/day for mice, 30 mg/kg/day for rats, and 10 mg/kg/day for dogs in the 13-week, 26-week, and 39-week repeat-dose studies, respectively.

Tenofovir alafenamide: The general toxicology profile of tenofovir alafenamide has been studied in mice, rats, dogs and monkeys. The target organs were the kidney and bone. The effects on the kidneys included cortical tubular basophilia and tubular karyomegaly in both rats and dogs and additionally cortical tubular degeneration/regeneration in dogs. These effects did not appear to meaningfully affect

renal function except for possibly related reduction in serum calcitriol (1,25-dihydroxyvitamin D3) that may be implicated in the bone effects (see below). The tenofovir alafenamide-related effects on the bone included decreases in bone mineral density and mineral content observed in both rats and dogs. In the 9-month dog study, animals dosed at 18/12 mg/kg/day (approximately 47 times the clinical exposure based on AUC) failed to mature skeletally. The NOAEL in the rat and dog was 25 mg/kg/day (approximately 13 times clinical tenofovir exposure based on AUC) and 2 mg/kg/day (approximately 4 times the clinical tenofovir exposure based on AUC), respectively. These effects were partially reversible upon treatment discontinuation.

Electrocardiographic effects occurred in the 9-month dog study and included prolongation of PR intervals at ≥ 6 mg/kg (approximately 15 times the clinical exposure based on AUC) and reduction in heart rate with an associated QT prolongation at 18/12 mg/kg (approximately 47 times the clinical exposure based on AUC); the heart rate changes were reversible following a three-month recovery period. The NOAEL was 2 mg/kg (approximately 4 times the clinical tenofovir exposure based on AUC). These effects might have been due to a reduction in triiodothyronine (T3) levels.

Carcinogenesis

Elvitegravir: In long-term carcinogenicity studies of elvitegravir were carried out in mice (104 weeks) and in rats for up to 88 weeks (males) and 90 weeks (females). No drug-related increases in tumor incidence were found in mice at doses up to 2000 mg/kg/day alone or in combination with 25 mg/kg/day RTV at exposures 3- and 14-fold, respectively, the human systemic exposure at the recommended daily dose of 150 mg. No drug-related increases in tumor incidence were found in rats at doses up to 2000 mg/kg/day at exposures 12- to 27-fold, respectively in male and female, the human systemic exposure.

Cobicistat: In a long-term carcinogenicity study in mice, no drug-related increases in tumor incidence were observed at doses up to 50 and 100 mg/kg/day (males and females, respectively). Cobicistat exposures at these doses were approximately 7 (male) and 16 (females) times, respectively, the human systemic exposure at the therapeutic daily dose. In a long-term carcinogenicity study of cobicistat in rats, an increased incidence of follicular cell adenomas and/or carcinomas in the thyroid gland was observed at doses of 25 and 50 mg/kg/day in males, and at 30 mg/kg/day in females. The follicular cell findings are considered to be rat-specific, secondary to hepatic microsomal enzyme induction and thyroid hormone imbalance, and are not relevant for humans. At the highest doses tested in the rat carcinogenicity study, systemic exposures were approximately 2 times the human systemic exposure at the therapeutic daily dose.

Emtricitabine: In long-term carcinogenicity studies of emtricitabine, no drug-related increases in tumor incidence were found in mice at doses up to 750 mg/kg/day (23 times the human systemic exposure at the therapeutic dose of 200 mg/day) or in rats at

doses up to 600 mg/kg/day (28 times the human systemic exposure at the therapeutic dose).

Tenofovir Alafenamide: Because there is a lower tenofovir exposure in rats and mice after tenofovir alafenamide administration compared to tenofovir disoproxil fumarate, carcinogenicity studies were conducted only with tenofovir disoproxil fumarate. Long-term oral carcinogenicity studies of tenofovir disoproxil fumarate in mice and rats were carried out at exposures up to approximately 10 times (mice) and 4 times (rats) those observed in humans at the 300 mg therapeutic dose of tenofovir disoproxil fumarate for HIV-1 infection. At the high dose in female mice, liver adenomas were increased at exposures 10 times that in humans. In rats, the study was negative for carcinogenic findings at exposures up to 4 times that observed in humans at the therapeutic dose.

Mutagenesis

Elvitegravir: Elvitegravir was not genotoxic in the reverse mutation bacterial test (Ames test) and the rat micronucleus assay. In an *in vitro* chromosomal aberration test, elvitegravir was negative with metabolic activation; however, an equivocal response was observed without activation.

Cobicistat: Cobicistat was not genotoxic in the reverse mutation bacterial test (Ames test), mouse lymphoma or rat micronucleus assays.

Emtricitabine: Emtricitabine was not genotoxic in the reverse mutation bacterial test (Ames test), mouse lymphoma or mouse micronucleus assays.

Tenofovir Alafenamide: Tenofovir alafenamide was not genotoxic in the reverse mutation bacterial test (Ames test), mouse lymphoma or rat micronucleus assays.

Reproductive Toxicology

Elvitegravir: Reproductive studies were conducted in rats and rabbits. Animal studies do not indicate direct or indirect harmful effects of elvitegravir with respect to pregnancy, fetal development, parturition or postnatal development. There were no effects on mating or fertility parameters.

Studies in animals have shown no evidence of teratogenicity or an effect on reproductive function. In offspring from rat and rabbit dams treated with elvitegravir during pregnancy, there were no toxicologically significant effects on developmental endpoints. The exposures at the embryo-fetal No Observed Adverse Effects Levels (NOAELs) in rats and rabbits were respectively 23 and 0.2 times higher than the exposure in humans at the recommended daily dose of 150 mg.

Elvitegravir did not affect fertility in male and female rats at approximately 16- and 30-fold higher exposures (AUC), respectively, than in humans at the therapeutic 150 mg daily dose.

Fertility was normal in the offspring of rats exposed daily from before birth (in utero) through sexual maturity at daily exposures (AUC) of approximately 18-fold higher than human exposures at the recommended 150 mg daily dose.

Cobicistat: Reproductive studies were conducted in rats and rabbits. Animal studies do not indicate direct or indirect harmful effects of cobicistat with respect to pregnancy, fetal development, parturition or postnatal development. There were no effects on mating or fertility parameters.

Studies in animals have shown no evidence of teratogenicity or an effect on reproductive function. In offspring from rat and rabbit dams treated with cobicistat during pregnancy, there were no toxicologically significant effects on developmental endpoints. The exposures at the embryo-fetal NOAELs in rats and rabbits were respectively 1.8 and 4.3 times higher than the exposure in humans at the recommended daily dose of 150 mg.

Cobicistat did not affect fertility in male or female rats at daily exposures (AUC) approximately 4-fold higher than human exposures at the recommended 150 mg daily dose. Fertility was normal in the offspring of rats exposed daily from before birth (in utero) through sexual maturity at daily exposures (AUC) of approximately 1.2-fold higher than human exposures at the recommended 150 mg daily dose.

Emtricitabine: The incidence of fetal variations and malformations was not increased in embryofetal toxicity studies performed with emtricitabine in mice at exposures (AUC) approximately 60-fold higher and in rabbits at approximately 120-fold higher than human exposures at the recommended daily dose.

Emtricitabine did not affect fertility in male rats at approximately 140-fold or in male and female mice at approximately 60 fold higher exposures (AUC) than in humans given the recommended 200 mg daily dose. Fertility was normal in the offspring of mice exposed daily from before birth (in utero) through sexual maturity at daily exposures (AUC) of approximately 60-fold higher than human exposures at the recommended 200 mg daily dose.

Tenofovir Alafenamide: There were no effects on fertility when tenofovir alafenamide was administered to male rats at a dose equivalent to 155 times the human dose based on body surface area comparisons for 28 days prior to mating and to female rats for 14 days prior to mating through day seven of gestation.

READ THIS FOR SAFE AND EFFECTIVE USE OF YOUR MEDICINE

PATIENT MEDICATION INFORMATION

GENVOYA®

(elvitegravir/cobicistat/emtricitabine/tenofovir alafenamide*) tablets
*as tenofovir alafenamide hemifumarate

Read this carefully before you start taking **Genvoya** and each time you get a refill. This leaflet is a summary and will not tell you everything about this drug. Talk to your healthcare professional about your medical condition and treatment and ask if there is any new information about **Genvoya**.

Serious Warnings and Precautions

- **“Flare-ups” of Hepatitis B Virus infection**, in which the disease suddenly returns in a worse way than before, can occur if you also have hepatitis B and stop taking **Genvoya**. Do not stop taking **Genvoya** without your doctor’s advice. If you stop taking **Genvoya**, tell your doctor immediately about any new, unusual or worsening symptoms that you notice after stopping treatment. After you stop taking **Genvoya**, your doctor will still need to check your health and take blood tests to check your liver. **Genvoya** is not approved for the treatment of hepatitis B virus infection.

What is **Genvoya** used for?

Genvoya is used to treat people with HIV infection. **Genvoya** is for adults and children who weigh at least 25 kg (55 lbs).

Genvoya is for people who do not have an HIV virus that is resistant to **Genvoya**. **Genvoya** has not been studied in children weighing less than 25 kg (55 lbs).

How does **Genvoya** work?

Genvoya lowers the amount of HIV in the blood (viral load).

HIV infection destroys CD4+ (T) cells. These cells are important to help the immune system fight infections. After a large number of T cells are destroyed, acquired immune deficiency syndrome (AIDS) develops.

Genvoya may help increase the count of CD4+ (T) cells. Lowering the amount of HIV in the blood and increasing the CD4+ (T) cells lower the chance of getting infections that happen when your immune system is weak.

Genvoya does not cure HIV infection or AIDS. The long-term effects of **Genvoya** are not known. People taking **Genvoya** may still get infections or other conditions that happen with HIV infection. Some of these conditions are pneumonia and *Mycobacterium avium* complex (MAC) infections. **It is very important that you see your doctor on a regular basis while taking Genvoya.**

Genvoya has not been shown to reduce the risk of passing HIV to others through sexual contact or blood. Continue to practice safe sex. Use condoms to lower the chance of sexual contact with body fluids such as semen, vaginal secretions, or blood. Do not re-use or share needles.

What are the ingredients in Genvoya?

Medicinal ingredients: elvitegravir, cobicistat, emtricitabine, tenofovir alafenamide* (*as tenofovir alafenamide hemifumarate)

Non-medicinal ingredients: croscarmellose sodium, hydroxypropyl cellulose, lactose monohydrate, magnesium stearate, microcrystalline cellulose, silicon dioxide, and sodium lauryl sulfate. The tablets are film-coated with a coating material containing polyvinyl alcohol, titanium dioxide, polyethylene glycol, talc, indigo carmine aluminum lake, and iron oxide yellow.

Genvoya comes in the following dosage forms:

Genvoya is available as tablets. Each tablet contains 150 mg of elvitegravir, 150 mg of cobicistat, 200 mg of emtricitabine and 10 mg of tenofovir alafenamide (equivalent to 11.2 mg of tenofovir alafenamide hemifumarate) as active ingredients. The tablets are green, capsule-shaped, film-coated, debossed with “GSI” on one side and “510” on the other side. Each bottle contains 30 tablets and a silica gel desiccant, polyester coil and is closed with a child-resistant closure.

Do not use Genvoya if:

- you are taking any medication that is listed in this pamphlet under “**Drugs that must not be taken with Genvoya**” or “**Drugs that should not be taken with Genvoya**”
- you are allergic to **Genvoya** or any of its ingredients. (see **What are the ingredients in Genvoya?**)

To help avoid side effects and ensure proper use, talk to your doctor before you take Genvoya. Talk about any health conditions or problems you may have, including if you:

- Also have a hepatitis B virus (HBV) infection at the same time and take **Genvoya**. Your HBV infection may get worse (flare-up) and symptoms worsen if you stop taking **Genvoya** (see Serious Warnings and Precautions box and Serious Side Effects table).

- Have a history of pancreatitis (swelling of the pancreas). If you develop symptoms of pancreatitis, such as nausea, vomiting and severe pain in the abdomen and/or back, contact your doctor.
- Have kidney problems. Kidney problems, including kidney failure, have occurred in patients taking tenofovir. If you have kidney problems and are taking **Genvoya** along with certain medicines such as non-steroidal anti-inflammatory drugs, your kidney problems could get worse.
- Have a history of bone fracture, bone loss or osteoporosis. Bone loss has happened in some people who took **Genvoya**.
- Have lactic acidosis (high levels of acid in the blood). See the Serious Side Effects table for symptoms and contact your doctor right away if you get these symptoms.
- Have severe liver problems including enlarged or fatty liver. See the Serious Side Effects table for symptoms and contact your doctor right away if you get these symptoms.

Do not run out of **Genvoya**. Refill your prescription or talk to your doctor before your **Genvoya** is all gone.

Do not stop taking **Genvoya** without first talking to your doctor.

If you stop taking **Genvoya**, your doctor will need to check your health often and do blood tests regularly for several months to check your HBV infection. Tell your doctor about any new or unusual symptoms you may have after you stop taking **Genvoya**.

Other warnings you should know about:

If you are pregnant or plan to become pregnant:

It is not known if **Genvoya** can harm your unborn child. Your doctor will decide if you should take **Genvoya**.

Pregnancy Registry: There is a pregnancy registry for women who take antiviral medicines during pregnancy. This registry collects information about your health and your baby's health. If you become pregnant while taking **Genvoya**, talk with your doctor about taking part in this registry.

If you are breast-feeding or plan to breast-feed:

Do not breast-feed if you have HIV because of the chance of passing the HIV virus to your baby. One of the ingredients of **Genvoya**, emtricitabine, can be passed to your baby in your breast milk and may cause harm to your baby. It is not known if the other components can be passed to your baby in breast milk. If you are a woman who has or will have a baby, talk with your doctor about the best way to feed your baby.

Blood Sugar and Fat Levels

Your blood sugar levels (glucose) or levels of fats (lipids) in your blood may increase with HIV treatment. Your doctor may order blood tests for you.

Tell your healthcare professional about all the medicines you take, including any drugs, vitamins, minerals, natural supplements or alternative medicines.

Drugs that must not be taken with Genvoya (contraindicated):

Drug Class	Medicinal Ingredient (Brand Name)
Alpha 1-adrenoreceptor antagonists	alfuzosin hydrochloride (Xatral [®])
Anticoagulants	apixaban (Eliquis [®]), rivaroxaban (Xarelto [®])
Anticonvulsants	carbamazepine (Tegretol [®]), phenobarbital and phenytoin (Dilantin [®])
Antihistamines	astemizole* (Hismanal [®]), terfenadine* (Seldane [®])
GI Motility Agents	cisapride*(Prepulsid [®])
Ergot derivatives	dihydroergotamine, ergonovine, ergotamine, methylergonovine, such as Cafergot [®] , Migranal [®] , D.H.E. 45 ^{®*} , Ergotrate [®] , Methergine ^{®*} , Migergot ^{®*} , Ergomar ^{®*} , and others.
HMG-CoA reductase inhibitors	lovastatin (Advicor [®] , Altoprev ^{®*} , Mevacor [®]), simvastatin (Simcor ^{®*} , Vytorin ^{®*} , Zocor [®])
Benzodiazepines	midazolam* (Versed [®]) when taken by mouth, triazolam (Halcion [®])
Neuroleptics	lurasidone (Latuda [®]), pimozide (Orap [®])
Antimycobacterials	rifampin (Rifadin [®] , Rifamate ^{®*} , Rifater [®] , Rofact [®])
Beta 2-adrenoceptor agonist	salmeterol (Advair [®] , Serevent [®])
PDE-5 inhibitors	sildenafil (Revatio [®]) when used to treat lung problems
Herbal products	<i>Hypericum perforatum</i> (St. John's wort)

* Not available in Canada

Drugs that should not be taken with Genvoya:

- Antiplatelets such as clopidogrel (Plavix[®])
- Any other medicines to treat HIV-1 infection.
- Any other medicines that contain elvitegravir (STRIBILD[®]).
- Any other medicines that contain cobicistat (STRIBILD, Symtuza[™],

TYBOST[®], Prezco**ix**[®]).

- Any other medicines that contain tenofovir (ATRIPLA[®], BIKTARVY[®], COMPLERA[®], DESCOVY[®], ODEFSEY[®], STRIBILD, Symtuza[™], TRUVADA[®], VEMLIDY[®], VIREAD[®]).
- Any other medicines that contain emtricitabine or lamivudine (ATRIPLA, BIKTARVY, COMPLERA, DESCOVY, EMTRIVA[®], ODEFSEY, STRIBILD, Symtuza, TRUVADA; 3TC, Combivir[®], Heptovir[®], Kivexa[®], Triumeq[®], Trizivir[®]).
- Any other medicines containing ritonavir (Norvir[®], Kaletra[®], Holkira[™] Pak).
- Adefovir (HEPSERA[®]).

Drugs that interact with Genvoya and where the dose of Genvoya or the dose of the other drug should be changed or other direction needed:

Drug Class	Medicinal Ingredient (Brand Name)
Antidepressants	trazodone
Antifungals	ketoconazole (Nizoral [®]), itraconazole (Sporanox [®]) and voriconazole (Vfend [®])
Antiarrhythmics	amiodarone (Cordarone [®]), flecainide (Tambacor [®]) and quinidine (Neudexta [®])
Antibacterials	clarithromycin (Biaxin [®]) and telithromycin (Ketek [®])
Antimycobacterials	rifabutin (Mycobutin [®])
Anticoagulants	warfarin (Coumadin [®]), dabigatran (Pradaxa [®]), edoxaban (Lixiana [®])
Antigout	colchicine
Antivirals	elbasvir/grazoprevir (Zepatier [®])
Beta-blockers	metoprolol (Lopressor [®]) and timolol
Calcium channel blockers	amlodipine (Norvasc [®]), diltiazem (Cardizem [®]), and felodipine
Corticosteroids	betamethasone, budesonide, dexamethasone, fluticasone (Flonase [®]), mometasone, and triamcinolone
Endothelial receptor antagonists	bosentan (Tracleer [®])
Hormonal contraceptives	drospirenone/ethinyl estradiol, norgestimate/ethinyl estradiol

Drug Class	Medicinal Ingredient (Brand Name)
Immunosuppressants	cyclosporine (Neoral [®]), sirolimus (Rapamune [®]) and tacrolimus (Prograf [®])
Medications or oral supplements containing polyvalent cations	Any medications, antacids, vitamins, and supplements containing magnesium, aluminum, calcium, iron, or zinc. These include antacids (for stomach ulcers, heartburn, or acid reflux), mineral supplements and vitamins that contain calcium or iron, and ulcer healing medication (sucralfate). Take medications, antacids, vitamins, and supplements containing magnesium, aluminum, calcium, iron, or zinc at least 2 hours before or after you take Genvoya
Neuroleptics	risperidone (Risperdal [®]) and perphenazine (Trilafon [®])
PDE-5 Inhibitors	sildenafil (Viagra [®]), tadalafil (Cialis [®] , Adcirca [®]), and vardenafil (Levitra [®])
Sedative/hypnotics	diazepam (Valium [®]), flurazepam and buspirone

These are not all the medicines that may cause problems if you take Genvoya. Be sure to tell your doctor about all the medicines you take.

Keep a complete list of all the prescription, nonprescription, and herbal medicines that you are taking, how much you take and how often you take them. Make a new list when medicines or herbal medicines are added or stopped, or if the dose changes. Give copies of this list to all your doctors and pharmacists **every** time you visit them or fill a prescription. This will give your doctor a complete picture of the medicines you use. Then he or she can decide the best approach for the situation.

How to take Genvoya:

Stay under a doctor's care when taking **Genvoya**. Do not change your treatment or stop treatment without first talking with your doctor.

When your **Genvoya** supply starts to run low, get more from your doctor or pharmacy. This is very important because the amount of virus in your blood may increase if the medicine is stopped for even a short time. If **Genvoya** is not taken on a regular basis, as prescribed, the HIV virus may become harder to treat.

Only take medicine that has been prescribed specifically for you.

Do not give **Genvoya** to others or take medicine prescribed for someone else.

Do not use if seal over bottle opening is broken or missing.

Usual dose:

Adults and children weighing 25 kg or more:

- The usual dose of **Genvoya** is one tablet orally (by mouth) once a day. Try to take the tablet at the same time each day. Swallow with plenty of water.
- **Genvoya** must be taken with food.

Adults on Dialysis:

- If you are on dialysis, take your daily dose of **Genvoya** following dialysis.

Overdose:

If you think you have taken too much **Genvoya**, contact your healthcare professional, hospital emergency department or regional Poison Control Centre immediately, even if there are no symptoms.

Missed Dose:

It is important that you do not miss any doses. If you miss a dose of **Genvoya** and it is less than 18 hours from the time you usually take **Genvoya**, then take the dose. If more than 18 hours has passed from the time you usually take **Genvoya**, then wait until the next scheduled daily dose. **Do not** take more than 1 dose of **Genvoya** in a day. **Do not** take 2 doses at the same time. Call your doctor or pharmacist if you are not sure what to do.

What are possible side effects from using Genvoya?

These are not all the possible side effects you may feel when taking **Genvoya**. If you get any side effects not listed here, contact your doctor. Please also see Serious Warnings and Precautions box.

The common side effects of **Genvoya** are:

- Diarrhea.
- Nausea.
- Headache.
- Tiredness.

Additional side effects may include:

- Gas.
- Swelling in the face, lips, tongue or throat (angioedema).
- Hives (urticaria).

Changes in your immune system (Immune Reconstitution Inflammatory Syndrome) can happen when you start taking HIV-1 medicines. Your immune system may get stronger and begin to fight infections that have been hidden in your body for a long time.

Autoimmune disorders (when the immune system attacks healthy body tissue), may also occur after you start taking medicines for HIV infection. Examples of this include: Grave's disease (which affects the thyroid gland), Guillain-Barré syndrome (which affects the nervous system), polymyositis (which affects the muscles), or autoimmune hepatitis (which affects the liver). Autoimmune disorders may occur many months after the start of treatment. Look for any other symptoms such as:

- high temperature (fever), redness, rash or swelling
- joint or muscle pain
- numbness or weakness beginning in the hands and feet and moving up towards the trunk of the body
- palpitations (chest pain) or rapid heart rate

If you notice these or any symptoms of inflammation or infection, tell your doctor immediately.

Serious side effects and what to do about them			
Symptom / effect	Talk to your healthcare professional		Stop taking drug and get immediate medical help
	Only if severe	In all cases	
<p><u>RARE</u> Effect: Lactic acidosis Symptoms:</p> <ul style="list-style-type: none"> • Feeling very weak or tired • Unusual muscle pain • Stomach pain with nausea and vomiting • Feeling unusually cold especially in arms and legs • Feeling dizzy or lightheaded • Fast or irregular heartbeat • Fast and deep breathing 		<ul style="list-style-type: none"> ✓ ✓ ✓ ✓ ✓ ✓ ✓ 	

<p><u>VERY RARE</u> Effect: Flare-ups of hepatitis B virus infection following drug discontinuation Symptoms:</p> <ul style="list-style-type: none"> • Jaundice (skin or the white part of eyes turn yellow) • Urine turns dark • Bowel movements (stools) turn light in color • Loss of appetite for several days or longer • Feeling sick to your stomach (nausea) • Stomach pain 		<p style="text-align: center;">✓</p> <p style="text-align: center;">✓</p> <p style="text-align: center;">✓</p> <p style="text-align: center;">✓</p> <p style="text-align: center;">✓</p> <p style="text-align: center;">✓</p>	
<p><u>VERY RARE</u> Effect: Hepatotoxicity (severe liver problems) with hepatomegaly (liver enlargement) and steatosis (fat in the liver) Symptoms:</p> <ul style="list-style-type: none"> • Jaundice (skin or the white part of eyes turn yellow) • Urine turns dark • Bowel movements (stools) turn light in color • Loss of appetite for several days or longer • Feeling sick to your stomach (nausea) • Stomach pain 		<p style="text-align: center;">✓</p> <p style="text-align: center;">✓</p> <p style="text-align: center;">✓</p> <p style="text-align: center;">✓</p> <p style="text-align: center;">✓</p> <p style="text-align: center;">✓</p>	

If you have a troublesome symptom or side effect that is not listed here or becomes bad enough to interfere with your daily activities, talk to your healthcare professional.

Reporting Side Effects

You can help improve the safe use of health products for Canadians by reporting serious and unexpected side effects to Health Canada. Your report may help to identify new side effects and change the product safety information.

3 ways to report:

- Online at MedEffect; <https://www.canada.ca/en/health-canada/services/drugs-health-products/medeffect-canada.html>;
- By calling 1-866-234-2345 (toll-free);
- By completing a Consumer Side Effect Reporting Form and sending it by:
 - Fax to 1-866-678-6789 (toll-free), or
 - Mail to: Canada Vigilance Program
Health Canada, Postal Locator 1908C
Ottawa, ON
K1A 0K9

Postage paid labels and the Consumer Side Effect Reporting Form are available at MedEffect at <https://www.canada.ca/en/health-canada/services/drugs-health-products/medeffect-canada.html>.

NOTE: Contact your healthcare professional if you need information about how to manage your side effects. The Canada Vigilance Program does not provide medical advice.

Storage:

- **Genvoya** should be stored below 30 °C (86 °F). It should remain stable until the expiration date printed on the label.
- Keep **Genvoya** in its original container and keep the container tightly closed.
- Keep out of reach and sight of children.

If you want more information about Genvoya:

- Talk to your healthcare professional.
- Find the full product monograph that is prepared for healthcare professionals and includes this Patient Medication Information by visiting the Health Canada website (<https://www.canada.ca/en/health-canada.html>), the manufacturer's website (www.gilead.ca), or by calling 1-866-207-4267.

This leaflet was prepared by Gilead Sciences, Inc.

May 8, 2020

Gilead Sciences, Inc.

Foster City, CA 94404

USA

Gilead Sciences Canada, Inc.
Mississauga, ON L5N 2W3

ATRIPLA[®], BIKTARVY[®], COMPLERA[®], DESCOVY[®], EMTRIVA[®], GENVOYA[®], HEPSERA[®], ODEFSEY[®], STRIBILD[®], TRUVADA[®], TYBOST[®], VEMLIDY[®], and VIREAD[®] are trademarks of Gilead Sciences, Inc. or its related companies.

All other marks referenced herein are the property of their respective owners.

©2020 Gilead Sciences, Inc.

e176096-GS-009

HIGHLIGHTS OF PRESCRIBING INFORMATION

These highlights do not include all the information needed to use GENVOYA safely and effectively. See full prescribing information for GENVOYA.

GENVOYA® (elvitegravir, cobicistat, emtricitabine, and tenofovir alafenamide) tablets, for oral use
Initial U.S. Approval: 2015

WARNING: POST TREATMENT ACUTE EXACERBATION OF HEPATITIS B

See full prescribing information for complete boxed warning.

Severe acute exacerbations of hepatitis B have been reported in patients who are coinfecting with HIV-1 and HBV and have discontinued products containing emtricitabine and/or tenofovir disoproxil fumarate (TDF), and may occur with discontinuation of GENVOYA. Hepatic function should be monitored closely in these patients. If appropriate, anti-hepatitis B therapy may be warranted. (5.1)

RECENT MAJOR CHANGES

Dosage and Administration, Testing When Initiating and During Treatment with GENVOYA (2.1)	08/2018
Dosage and Administration, Recommended Dosage (2.2)	12/2018
Dosage and Administration, Renal Impairment (2.3)	12/2018
Dosage and Administration, Not Recommended During Pregnancy (2.5)	11/2018
Contraindications (4)	11/2018
Warnings and Precautions, New Onset or Worsening Renal Impairment (5.4)	12/2018

INDICATIONS AND USAGE

GENVOYA is a four-drug combination of elvitegravir, an HIV-1 integrase strand transfer inhibitor (INSTI), cobicistat, a CYP3A inhibitor, and emtricitabine and tenofovir alafenamide (TAF), both HIV-1 nucleoside analog reverse transcriptase inhibitors (NRTIs), and is indicated as a complete regimen for the treatment of HIV-1 infection in adults and pediatric patients weighing at least 25 kg who have no antiretroviral treatment history or to replace the current antiretroviral regimen in those who are virologically-suppressed (HIV-1 RNA less than 50 copies per mL) on a stable antiretroviral regimen for at least 6 months with no history of treatment failure and no known substitutions associated with resistance to the individual components of GENVOYA. (1)

DOSAGE AND ADMINISTRATION

- Testing: Prior to or when initiating GENVOYA test for hepatitis B virus infection. Prior to or when initiating GENVOYA, and during treatment on a clinically appropriate schedule, assess serum creatinine, estimated creatinine clearance, urine glucose, and urine protein in all patients. In patients with chronic kidney disease, also assess serum phosphorus. (2.1)
- Recommended dosage: One tablet taken orally once daily with food in patients with body weight at least 25 kg and a creatinine clearance greater than or equal to 30 mL per minute, or in adult patients with creatinine clearance less than 15 mL per minute who are receiving chronic hemodialysis. On days of hemodialysis, administer GENVOYA after hemodialysis. (2.2)
- Renal impairment: GENVOYA is not recommended in patients with estimated creatinine clearance of 15 to below 30 mL per minute, or below 15 mL per minute who are not receiving chronic hemodialysis. (2.3)
- Hepatic impairment: GENVOYA is not recommended in patients with severe hepatic impairment. (2.4)

DOSAGE FORMS AND STRENGTHS

Tablets: 150 mg of elvitegravir, 150 mg of cobicistat, 200 mg of emtricitabine, and 10 mg of tenofovir alafenamide. (3)

CONTRAINDICATIONS

Coadministration of GENVOYA is contraindicated with drugs that:

- Are highly dependent on CYP3A for clearance and for which elevated plasma concentrations are associated with serious adverse events. (4)
- Strongly induce CYP3A, which may lead to lower exposure of one or more components and loss of efficacy of GENVOYA and possible resistance. (4)

WARNINGS AND PRECAUTIONS

- Risk of adverse reactions or loss of virologic response due to drug interactions: The concomitant use of GENVOYA and other drugs may result in known or potentially significant drug interactions, some of which may lead to loss of therapeutic effect of GENVOYA and possible development of resistance; and possible clinically significant adverse reactions from greater exposures of concomitant drugs. (5.2)
- Immune reconstitution syndrome: May necessitate further evaluation and treatment. (5.3)
- New onset or worsening renal impairment: Assess serum creatinine, estimated creatinine clearance, urine glucose and urine protein when initiating GENVOYA and during therapy on a clinically appropriate schedule in all patients. Also assess serum phosphorus in patients with chronic kidney disease. (5.4)
- Lactic acidosis/severe hepatomegaly with steatosis: Discontinue treatment in patients who develop symptoms or laboratory findings suggestive of lactic acidosis or pronounced hepatotoxicity. (5.5)

ADVERSE REACTIONS

Most common adverse reaction (incidence greater than or equal to 10%, all grades) is nausea. (6.1)

To report SUSPECTED ADVERSE REACTIONS, contact Gilead Sciences, Inc. at 1-800-GILEAD-5 or FDA at 1-800-FDA-1088 or www.fda.gov/medwatch.

DRUG INTERACTIONS

- GENVOYA should not be administered with other antiretroviral medications for treatment of HIV-1 infection. (7.1)
- GENVOYA can alter the concentration of drugs metabolized by CYP3A or CYP2D6. Drugs that induce CYP3A can alter the concentrations of one or more components of GENVOYA. Consult the full prescribing information prior to and during treatment for potential drug-drug interactions. (4, 7.2, 7.3, 12.3)

USE IN SPECIFIC POPULATIONS

- Pregnancy: Not recommended for use during pregnancy because of substantially lower exposures of cobicistat and elvitegravir during pregnancy. GENVOYA should not be initiated in pregnant individuals. (2.5, 8.1)
- Lactation: Breastfeeding is not recommended due to the potential for HIV transmission. (8.2)
- Pediatrics: Not recommended for patients weighing less than 25 kg. (8.4)

See 17 for PATIENT COUNSELING INFORMATION and FDA-approved patient labeling.

Revised: 02/2019

FULL PRESCRIBING INFORMATION: CONTENTS***WARNING: POST TREATMENT ACUTE EXACERBATION OF HEPATITIS B****1 INDICATIONS AND USAGE****2 DOSAGE AND ADMINISTRATION**

- 2.1 Testing When Initiating and During Treatment with GENVOYA
- 2.2 Recommended Dosage
- 2.3 Not Recommended in Patients with Severe Renal Impairment
- 2.4 Not Recommended in Patients with Severe Hepatic Impairment
- 2.5 Not Recommended During Pregnancy

3 DOSAGE FORMS AND STRENGTHS**4 CONTRAINDICATIONS****5 WARNINGS AND PRECAUTIONS**

- 5.1 Severe Acute Exacerbation of Hepatitis B in Patients Coinfected with HIV-1 and HBV
- 5.2 Risk of Adverse Reactions or Loss of Virologic Response Due to Drug Interactions
- 5.3 Immune Reconstitution Syndrome
- 5.4 New Onset or Worsening Renal Impairment
- 5.5 Lactic Acidosis/Severe Hepatomegaly with Steatosis

6 ADVERSE REACTIONS

- 6.1 Clinical Trials Experience
- 6.2 Postmarketing Experience

7 DRUG INTERACTIONS

- 7.1 Not Recommended with Other Antiretroviral Medications
- 7.2 Potential for GENVOYA to Affect Other Drugs
- 7.3 Potential for Other Drugs to Affect One or More Components of GENVOYA
- 7.4 Drugs Affecting Renal Function
- 7.5 Established and Other Potentially Significant Interactions
- 7.6 Drugs without Clinically Significant Interactions with GENVOYA

8 USE IN SPECIFIC POPULATIONS

- 8.1 Pregnancy
- 8.2 Lactation
- 8.4 Pediatric Use
- 8.5 Geriatric Use
- 8.6 Renal Impairment
- 8.7 Hepatic Impairment

10 OVERDOSAGE**11 DESCRIPTION****12 CLINICAL PHARMACOLOGY**

- 12.1 Mechanism of Action
- 12.2 Pharmacodynamics
- 12.3 Pharmacokinetics
- 12.4 Microbiology

13 NONCLINICAL TOXICOLOGY

- 13.1 Carcinogenesis, Mutagenesis, Impairment of Fertility
- 13.2 Animal Toxicology and/or Pharmacology

14 CLINICAL STUDIES

- 14.1 Description of Clinical Trials
- 14.2 Clinical Trial Results in HIV-1 Treatment-Naïve Subjects
- 14.3 Clinical Trial Results in HIV-1 Virologically-Suppressed Subjects Who Switched to GENVOYA
- 14.4 Clinical Trial Results in HIV-1 Infected Subjects with Renal Impairment
- 14.5 Clinical Trial Results in HIV-1 Infected Pediatric Subjects Between the Ages of 6 to Less than 18

16 HOW SUPPLIED/STORAGE AND HANDLING**17 PATIENT COUNSELING INFORMATION**

* Sections or subsections omitted from the full prescribing information are not listed.

FULL PRESCRIBING INFORMATION

WARNING: POST TREATMENT ACUTE EXACERBATION OF HEPATITIS B

Severe acute exacerbations of hepatitis B have been reported in patients who are coinfecting with HIV-1 and HBV and have discontinued products containing emtricitabine and/or tenofovir disoproxil fumarate (TDF), and may occur with discontinuation of GENVOYA. Hepatic function should be monitored closely with both clinical and laboratory follow-up for at least several months in patients who are coinfecting with HIV-1 and HBV and discontinue GENVOYA. If appropriate, anti-hepatitis B therapy may be warranted [see *Warnings and Precautions (5.1)*].

1 INDICATIONS AND USAGE

GENVOYA is indicated as a complete regimen for the treatment of HIV-1 infection in adults and pediatric patients weighing at least 25 kg who have no antiretroviral treatment history or to replace the current antiretroviral regimen in those who are virologically-suppressed (HIV-1 RNA less than 50 copies per mL) on a stable antiretroviral regimen for at least 6 months with no history of treatment failure and no known substitutions associated with resistance to the individual components of GENVOYA [see *Clinical Studies (14)*].

2 DOSAGE AND ADMINISTRATION

2.1 Testing When Initiating and During Treatment with GENVOYA

Prior to or when initiating GENVOYA, test patients for hepatitis B virus infection [see *Warnings and Precautions (5.1)*].

Prior to or when initiating GENVOYA, and during treatment with GENVOYA on a clinically appropriate schedule, assess serum creatinine, estimated creatinine clearance, urine glucose and urine protein in all patients. In patients with chronic kidney disease, also assess serum phosphorus [see *Warnings and Precautions (5.4)*].

2.2 Recommended Dosage

GENVOYA is a four-drug fixed dose combination product containing 150 mg of elvitegravir, 150 mg of cobicistat, 200 mg of emtricitabine, and 10 mg of tenofovir alafenamide (TAF). The recommended dosage of GENVOYA is one tablet taken orally once daily with food in:

- adults and pediatric patients with body weight at least 25 kg and creatinine clearance greater than or equal to 30 mL per minute; or

- adults with creatinine clearance below 15 mL per minute who are receiving chronic hemodialysis. On days of hemodialysis, administer GENVOYA after completion of hemodialysis treatment [see *Use in Specific Populations (8.6)* and *Clinical Pharmacology (12.3)*].

2.3 Not Recommended in Patients with Severe Renal Impairment

GENVOYA is not recommended in patients with:

- severe renal impairment (estimated creatinine clearance of 15 to below 30 mL per minute); or
- end stage renal disease (ESRD; estimated creatinine clearance below 15 mL per minute) who are not receiving chronic hemodialysis [see *Dosage and Administration (2.2)* and *Use in Specific Populations (8.6)*].

2.4 Not Recommended in Patients with Severe Hepatic Impairment

GENVOYA is not recommended in patients with severe hepatic impairment (Child-Pugh Class C) [see *Use in Specific Populations (8.7)* and *Clinical Pharmacology (12.3)*].

2.5 Not Recommended During Pregnancy

GENVOYA is not recommended for use during pregnancy because of substantially lower exposures of cobicistat and elvitegravir during the second and third trimesters [see *Use in Specific Populations (8.1)*].

GENVOYA should not be initiated in pregnant individuals. An alternative regimen is recommended for individuals who become pregnant during therapy with GENVOYA [see *Use in Specific Populations (8.1)*].

3 DOSAGE FORMS AND STRENGTHS

Each GENVOYA tablet contains 150 mg of elvitegravir, 150 mg of cobicistat, 200 mg of emtricitabine, and 10 mg of tenofovir alafenamide (TAF) (equivalent to 11.2 mg of tenofovir alafenamide fumarate).

The tablets are green, capsule-shaped, film-coated tablets, debossed with “GSI” on one side of the tablet and the number “510” on the other side of the tablet.

4 CONTRAINDICATIONS

Coadministration of GENVOYA is contraindicated with drugs that are highly dependent on CYP3A for clearance and for which elevated plasma concentrations are associated with serious and/or life-threatening events. These drugs and other contraindicated drugs (which may lead to reduced efficacy of GENVOYA and possible resistance) are listed below [see *Drug Interactions (7.5)* and *Clinical Pharmacology (12.3)*].

- Alpha 1-adrenoreceptor antagonist: alfuzosin
- Anticonvulsants: carbamazepine, phenobarbital, phenytoin
- Antimycobacterial: rifampin
- Antipsychotics: lurasidone, pimozide
- Ergot Derivatives: dihydroergotamine, ergotamine, methylergonovine
- GI Motility Agent: cisapride
- Herbal Products: St. John's wort (*Hypericum perforatum*)
- Lipid-modifying Agents: lomitapide, lovastatin, simvastatin
- Phosphodiesterase-5 (PDE-5) Inhibitor: sildenafil when administered as REVATIO® for the treatment of pulmonary arterial hypertension
- Sedative/hypnotics: triazolam, orally administered midazolam

5 WARNINGS AND PRECAUTIONS

5.1 Severe Acute Exacerbation of Hepatitis B in Patients Coinfected with HIV-1 and HBV

Patients with HIV-1 should be tested for the presence of hepatitis B virus (HBV) before or when initiating antiretroviral therapy [see *Dosage and Administration (2.1)*].

Severe acute exacerbations of hepatitis B (e.g., liver decompensation and liver failure) have been reported in patients who are coinfecting with HIV-1 and HBV and have discontinued products containing emtricitabine and/or tenofovir disoproxil fumarate (TDF), and may occur with discontinuation of GENVOYA. Patients coinfecting with HIV-1 and HBV who discontinue GENVOYA should be closely monitored with both clinical and laboratory follow-up for at least several months after stopping treatment. If appropriate, anti-hepatitis B therapy may be warranted, especially in patients with advanced liver disease or cirrhosis, since post-treatment exacerbation of hepatitis may lead to hepatic decompensation and liver failure.

5.2 Risk of Adverse Reactions or Loss of Virologic Response Due to Drug Interactions

The concomitant use of GENVOYA and other drugs may result in known or potentially significant drug interactions, some of which may lead to [see *Contraindications (4) and Drug Interactions (7.5)*]:

- Loss of therapeutic effect of GENVOYA and possible development of resistance.
- Possible clinically significant adverse reactions from greater exposures of concomitant drugs.

See Table 5 for steps to prevent or manage these possible and known significant drug interactions, including dosing recommendations. Consider the potential for drug interactions prior to and during GENVOYA therapy; review concomitant medications

during GENVOYA therapy; and monitor for the adverse reactions associated with the concomitant drugs.

5.3 Immune Reconstitution Syndrome

Immune reconstitution syndrome has been reported in patients treated with combination antiretroviral therapy, including emtricitabine, a component of GENVOYA. During the initial phase of combination antiretroviral treatment, patients whose immune system responds may develop an inflammatory response to indolent or residual opportunistic infections [such as *Mycobacterium avium* infection, cytomegalovirus, *Pneumocystis jirovecii* pneumonia (PCP), or tuberculosis], which may necessitate further evaluation and treatment.

Autoimmune disorders (such as Graves' disease, polymyositis, and Guillain-Barré syndrome) have also been reported to occur in the setting of immune reconstitution, however, the time to onset is more variable, and can occur many months after initiation of treatment.

5.4 New Onset or Worsening Renal Impairment

Renal impairment, including cases of acute renal failure and Fanconi syndrome (renal tubular injury with severe hypophosphatemia), has been reported with the use of tenofovir prodrugs in both animal toxicology studies and human trials. In clinical trials of GENVOYA, there have been no cases of Fanconi syndrome or Proximal Renal Tubulopathy (PRT). In clinical trials of GENVOYA in treatment-naïve subjects and in virologically suppressed subjects switched to GENVOYA with estimated creatinine clearance greater than 50 mL per minute, renal serious adverse events or discontinuations due to renal adverse reactions were encountered in less than 1% of participants treated with GENVOYA. In a study of virologically suppressed subjects with baseline estimated creatinine clearance between 30 and 69 mL per minute treated with GENVOYA for a median duration of 144 weeks, GENVOYA was permanently discontinued due to worsening renal function in three of 80 (4%) subjects with a baseline estimated creatinine clearance between 30 and 50 mL per minute and two of 162 (1%) with a baseline estimated creatinine clearance greater than or equal to 50 mL per minute [see *Adverse Reactions* (6.1)]. GENVOYA is not recommended in patients with estimated creatinine clearance of 15 to below 30 mL per minute, or in patients with estimated creatinine clearance below 15 mL per minute who are not receiving chronic hemodialysis.

Patients taking tenofovir prodrugs who have impaired renal function and those taking nephrotoxic agents including non-steroidal anti-inflammatory drugs are at increased risk of developing renal-related adverse reactions.

Prior to or when initiating GENVOYA, and during treatment with GENVOYA on a clinically appropriate schedule, assess serum creatinine, estimated creatinine clearance, urine glucose and urine protein in all patients. In patients with chronic kidney disease, also assess serum phosphorus. Discontinue GENVOYA in patients who develop clinically significant decreases in renal function or evidence of Fanconi syndrome.

Cobicistat, a component of GENVOYA, produces elevations of serum creatinine due to inhibition of tubular secretion of creatinine without affecting glomerular filtration [see *Adverse Reactions (6.1)*]. The elevation is typically seen within 2 weeks of starting therapy and is reversible after discontinuation. Patients who experience a confirmed increase in serum creatinine of greater than 0.4 mg per dL from baseline should be closely monitored for renal safety.

5.5 Lactic Acidosis/Severe Hepatomegaly with Steatosis

Lactic acidosis and severe hepatomegaly with steatosis, including fatal cases, have been reported with the use of nucleoside analogs, including emtricitabine, a component of GENVOYA, and tenofovir DF, another prodrug of tenofovir, alone or in combination with other antiretrovirals. Treatment with GENVOYA should be suspended in any patient who develops clinical or laboratory findings suggestive of lactic acidosis or pronounced hepatotoxicity (which may include hepatomegaly and steatosis even in the absence of marked transaminase elevations).

6 ADVERSE REACTIONS

The following adverse drug reactions are discussed in other sections of the labeling:

- Severe Acute Exacerbations of Hepatitis B [see *Boxed Warning and Warnings and Precautions (5.1)*]
- Immune Reconstitution Syndrome [see *Warnings and Precautions (5.3)*]
- New Onset or Worsening Renal Impairment [see *Warnings and Precautions (5.4)*]
- Lactic Acidosis/Severe Hepatomegaly with Steatosis [see *Warnings and Precautions (5.5)*]

6.1 Clinical Trials Experience

Because clinical trials are conducted under widely varying conditions, adverse reaction rates observed in the clinical trials of a drug cannot be directly compared to rates in the clinical trials of another drug and may not reflect the rates observed in practice.

Clinical Trials in Treatment-Naïve Adults

The primary safety assessment of GENVOYA was based on Week 144 pooled data from 1,733 subjects in two randomized, double-blind, active-controlled trials, Study 104 and Study 111, in antiretroviral treatment-naïve HIV-1 infected adult subjects. A total of 866 subjects received one tablet of GENVOYA once daily [see *Clinical Studies (14.2)*].

The most common adverse reaction (all Grades) reported in at least 10% of subjects in the GENVOYA group was nausea. The proportion of subjects who discontinued treatment with GENVOYA or STRIBILD® due to adverse events, regardless of severity, was 1% and 2%, respectively. Table 1 displays the frequency of adverse reactions (all Grades) greater than or equal to 5% in the GENVOYA group.

Table 1 Adverse Reactions^a (All Grades) Reported in ≥ 5% of HIV-1 Infected Treatment-Naïve Adults Receiving GENVOYA in Studies 104 and 111 (Week 144 analysis)

	GENVOYA N=866	STRIBILD N=867
Nausea	11%	13%
Diarrhea	7%	9%
Headache	6%	5%
Fatigue	5%	4%

a. Frequencies of adverse reactions are based on all adverse events attributed to study drugs by the investigator.

The majority of events presented in Table 1 occurred at severity Grade 1.

Clinical Trials in Virologically Suppressed Adults

The safety of GENVOYA in virologically-suppressed adults was based on Week 96 data from 959 subjects in a randomized, open-label, active-controlled trial (Study 109) in which virologically-suppressed subjects were switched from a TDF-containing combination regimen to GENVOYA. Overall, the safety profile of GENVOYA in subjects in this study was similar to that of treatment-naïve subjects [see *Clinical Studies (14.3)*]. Additional adverse reactions observed with GENVOYA in Study 109 included suicidal ideation, suicidal behavior, and suicide attempt (<1% combined); all of these events were serious and all occurred in subjects with a preexisting history of depression or psychiatric illness.

Clinical Trials in Adult Subjects with Renal Impairment

In an open-label trial (Study 112), 248 HIV-1 infected subjects with estimated creatinine clearance between 30 and 69 mL per minute (by Cockcroft-Gault method) were treated with GENVOYA for a median duration of 144 weeks. Of these subjects, 65% had previously been on a stable TDF-containing regimen. A total of 5 subjects permanently discontinued GENVOYA due to the development of renal adverse events through Week 96. Three of these five were among the 80 subjects with baseline estimated creatinine clearance of less than 50 mL/min and two subjects were among the 162 subjects with baseline estimated creatinine clearance of greater than or equal to 50 mL/min. There were no further renal discontinuations between Weeks 96 and 144. Overall, renally impaired subjects receiving GENVOYA in this study had a mean serum creatinine of 1.5 mg/dL at baseline and 1.4 mg/dL at Week 144. Otherwise, the safety profile of GENVOYA in subjects in this study was similar to that of subjects with normal renal function.

Virologically-Suppressed Adults with End Stage Renal Disease (ESRD) Receiving Chronic Hemodialysis

The safety of GENVOYA in subjects with end stage renal disease (ESRD) (estimated creatinine clearance of less than 15 mL/min) on chronic hemodialysis was assessed in

55 subjects (Study 1825) [see *Clinical Studies (14.4)*]. The most commonly reported adverse reaction (adverse event assessed as causally related by investigator and all grades) was nausea (7%). Serious adverse events were reported in 53% of subjects and the most common serious adverse events were pneumonia (13%), fluid overload (7%), hyperkalemia (7%) and osteomyelitis (7%). Overall 5% of subjects permanently discontinued treatment due to an adverse event.

Renal Laboratory Tests and Renal Safety

Treatment-Naïve Adults:

Cobicistat (a component of GENVOYA) has been shown to increase serum creatinine due to inhibition of tubular secretion of creatinine without affecting glomerular filtration [see *Clinical Pharmacology (12.2)*]. Increases in serum creatinine occurred by Week 2 of treatment and remained stable through 144 weeks.

In two 144-week randomized, controlled trials in a total of 1,733 treatment-naïve adults with a median baseline estimated creatinine clearance of 115 mL per minute, mean serum creatinine increased by less than 0.1 mg per dL in the GENVOYA group and by 0.1 mg per dL in the STRIBILD group from baseline to Week 144.

Virologically Suppressed Adults:

In a study of 1,436 virologically-suppressed TDF-treated adults with a mean baseline estimated creatinine clearance of 112 mL per minute who were randomized to continue their treatment regimen or switch to GENVOYA, at Week 96 mean serum creatinine was similar to baseline for both those continuing baseline treatment and those switching to GENVOYA.

Bone Mineral Density Effects

Treatment-Naïve Adults:

In a pooled analysis of Studies 104 and 111, the effects of GENVOYA compared to STRIBILD on bone mineral density (BMD) change from baseline to Week 144 were assessed by dual-energy X-ray absorptiometry (DXA). The mean percentage change in BMD from baseline to Week 144 was -0.92% with GENVOYA compared to -2.95% with STRIBILD at the lumbar spine and -0.75% compared to -3.36% at the total hip. BMD declines of 5% or greater at the lumbar spine were experienced by 15% of GENVOYA subjects and 29% of STRIBILD subjects. BMD declines of 7% or greater at the femoral neck were experienced by 15% of GENVOYA subjects and 29% of STRIBILD subjects. The long-term clinical significance of these BMD changes is not known.

Virologically Suppressed Adults:

In Study 109, TDF-treated subjects were randomized to continue their TDF-based regimen or switch to GENVOYA; changes in BMD from baseline to Week 96 were assessed by DXA. Mean BMD increased in subjects who switched to GENVOYA

(2.12% lumbar spine, 2.44% total hip) and decreased slightly in subjects who continued their baseline regimen (-0.09% lumbar spine, -0.46% total hip). BMD declines of 5% or greater at the lumbar spine were experienced by 2% of GENVOYA subjects and 6% of subjects who continued their TDF-based regimen. BMD declines of 7% or greater at the femoral neck were experienced by 2% of GENVOYA subjects and 7% of subjects who continued their TDF-based regimen. The long-term clinical significance of these BMD changes is not known.

Laboratory Abnormalities:

The frequency of laboratory abnormalities (Grades 3–4) occurring in at least 2% of subjects receiving GENVOYA in Studies 104 and 111 are presented in Table 2.

Table 2 Laboratory Abnormalities (Grades 3–4) Reported in ≥ 2% of Subjects Receiving GENVOYA in Studies 104 and 111 (Week 144 analysis)

Laboratory Parameter Abnormality ^a	GENVOYA N=866	STRIBILD N=867
Creatine Kinase (≥10.0 x ULN)	11%	10%
LDL-cholesterol (fasted) (>190 mg/dL)	11%	5%
Total cholesterol (fasted) (>300mg/dL)	4%	3%
Amylase	3%	5%
ALT	3%	3%
AST	3%	4%
Urine RBC (Hematuria) (>75 RBC/HPF)	3%	3%

a. Frequencies are based on treatment-emergent laboratory abnormalities.

Serum Lipids:

Subjects receiving GENVOYA experienced greater increases in serum lipids compared to those receiving STRIBILD.

Changes from baseline in total cholesterol, HDL-cholesterol, LDL-cholesterol, triglycerides and total cholesterol to HDL ratio are presented in Table 3.

Table 3 Lipid Values, Mean Change from Baseline, Reported in Subjects Receiving GENVOYA or STRIBILD in Studies 104 and 111^a

	GENVOYA N=866		STRIBILD N=867	
	Baseline	Week 144	Baseline	Week 144
	mg/dL	Change ^b	mg/dL	Change ^b
Total Cholesterol (fasted)	162 [N=647]	+31 [N=647]	165 [N=627]	+14 [N=627]
Triglycerides (fasted)	111 [N=647]	+29 [N=647]	115 [N=627]	+17 [N=627]

	GENVOYA N=866		STRIBILD N=867	
	Baseline	Week 144	Baseline	Week 144
	mg/dL	Change ^b	mg/dL	Change ^b
LDL-cholesterol (fasted)	103 [N=647]	+20 [N=643]	107 [N=628]	+8 [N=628]
HDL-cholesterol (fasted)	47 [N=647]	+7 [N=647]	46 [N=627]	+3 [N=627]
Total Cholesterol to HDL ratio	3.7 [N=647]	0.2 [N=647]	3.8 [N=627]	0.1 [N=627]

- a. Excludes subjects who received lipid lowering agents during the treatment period.
- b. The change from baseline is the mean of within-subject changes from baseline for subjects with both baseline and Week 144 values.

Clinical Trials in Pediatric Subjects:

Safety in Pediatric Patients

The safety of GENVOYA in HIV-1 infected pediatric subjects was evaluated in treatment-naïve subjects between the ages of 12 to less than 18 years and weighing at least 35 kg (N=50) through Week 48 (cohort 1), and in virologically-suppressed subjects between the ages of 6 to less than 12 years and weighing at least 25 kg (N=23) through Week 24 (cohort 2) in an open-label clinical trial (Study 106) [see *Clinical Studies (14.5)*]. With the exception of a decrease in the mean CD4+ cell count observed in cohort 2 of Study 106, the safety profile in pediatric subjects who received treatment with GENVOYA was similar to that in adults. One 13-year-old female subject developed unexplained uveitis while receiving GENVOYA that resolved and did not require discontinuation of GENVOYA.

Bone Mineral Density Effects

Cohort 1: Treatment-naïve adolescents (12 to less than 18 years; at least 35 kg)

Among the subjects in cohort 1 receiving GENVOYA, mean BMD increased from baseline to Week 48, + 4.2% at the lumbar spine and + 1.3% for the total body less head (TBLH). Mean changes from baseline BMD Z-scores were -0.07 for lumbar spine and -0.20 for TBLH at Week 48. One GENVOYA subject had significant (at least 4%) lumbar spine BMD loss at Week 48.

Cohort 2: Virologically-suppressed children (6 to less than 12 years; at least 25 kg)

Among the subjects in cohort 2 receiving GENVOYA, mean BMD increased from baseline to Week 24, +2.9% at the lumbar spine and +1.7% for TBLH. Mean changes from baseline BMD Z-scores were -0.06 for lumbar spine and -0.18 for TBLH at Week 24. Two GENVOYA subjects had significant (at least 4%) lumbar spine BMD loss at Week 24.

Change from Baseline in CD4+ cell counts

Cohort 2: Virologically-suppressed children (6 to less than 12 years; at least 25 kg)

Cohort 2 of Study 106 evaluated pediatric subjects (N=23) who were virologically-suppressed and who switched from their antiretroviral regimen to GENVOYA. Although all subjects had HIV-1 RNA < 50 copies/mL, there was a decrease from baseline in CD4+ cell count at Week 24. The mean baseline and mean change from baseline in CD4+ cell count and in CD4% from Week 2 to Week 24 are presented in Table 4. All subjects maintained their CD4+ cell counts above 400 cells/mm³ [see *Pediatric Use (8.4) and Clinical Studies (14.5)*].

Table 4 Mean Change in CD4+ Count and Percentage from Baseline to Week 24 in Virologically-Suppressed Pediatric Patients from 6 to <12 Years Who Switched to GENVOYA

	Baseline	Mean Change from Baseline			
		Week 2	Week 4	Week 12	Week 24
CD4+ Cell Count (cells/mm ³)	966 (201.7) ^a	-162	-125	-162	-150
CD4%	40 (5.3) ^a	+0.5%	-0.1%	-0.8%	-1.5%

a. Mean (SD)

6.2 Postmarketing Experience

The following events have been identified during post approval use of products containing TAF, including GENVOYA. Because these events are reported voluntarily from a population of uncertain size, it is not always possible to reliably estimate their frequency or establish a causal relationship to drug exposure.

Skin and Subcutaneous Tissue Disorders

Angioedema, urticaria, and rash

7 DRUG INTERACTIONS

7.1 Not Recommended with Other Antiretroviral Medications

GENVOYA is a complete regimen for the treatment of HIV-1 infection; therefore, coadministration of GENVOYA with other antiretroviral medications for treatment of HIV-1 infection should be avoided. Complete information regarding potential drug-drug interactions with other antiretroviral medications is not provided [see *Contraindications (4), Warnings and Precautions (5.2) and Clinical Pharmacology (12.3)*].

7.2 Potential for GENVOYA to Affect Other Drugs

Cobicistat, a component of GENVOYA, is an inhibitor of CYP3A and CYP2D6 and an inhibitor of the following transporters: P-glycoprotein (P-gp), BCRP, OATP1B1 and

OATP1B3. Thus, coadministration of GENVOYA with drugs that are primarily metabolized by CYP3A or CYP2D6, or are substrates of P-gp, BCRP, OATP1B1 or OATP1B3 may result in increased plasma concentrations of such drugs (see Table 5). Elvitegravir is a modest inducer of CYP2C9 and may decrease the plasma concentrations of CYP2C9 substrates. TAF is not an inhibitor of CYP1A2, CYP2B6, CYP2C8, CYP2C9, CYP2C19, CYP2D6, or UGT1A1. TAF is a weak inhibitor of CYP3A *in vitro*. TAF is not an inhibitor or inducer of CYP3A *in vivo*.

7.3 Potential for Other Drugs to Affect One or More Components of GENVOYA

Elvitegravir and cobicistat, components of GENVOYA, are metabolized by CYP3A. Cobicistat is also metabolized, to a minor extent, by CYP2D6.

Drugs that induce CYP3A activity are expected to increase the clearance of elvitegravir and cobicistat, resulting in decreased plasma concentration of cobicistat, elvitegravir, and TAF, which may lead to loss of therapeutic effect of GENVOYA and development of resistance (see Table 5).

Coadministration of GENVOYA with other drugs that inhibit CYP3A may decrease the clearance and increase the plasma concentration of cobicistat (see Table 5).

TAF, a component of GENVOYA, is a substrate of P-gp, BCRP, OATP1B1 and OATP1B3. Drugs that inhibit P-gp and/or BCRP, such as cobicistat, may increase the absorption of TAF (see Table 13). However, when TAF is administered as a component of GENVOYA, its availability is increased by cobicistat and a further increase of TAF concentrations is not expected upon coadministration of an additional P-gp and/or BCRP inhibitor. Drugs that induce P-gp activity are expected to decrease the absorption of TAF, resulting in decreased plasma concentration of TAF.

7.4 Drugs Affecting Renal Function

Because emtricitabine and tenofovir are primarily excreted by the kidneys by a combination of glomerular filtration and active tubular secretion, coadministration of GENVOYA with drugs that reduce renal function or compete for active tubular secretion may increase concentrations of emtricitabine, tenofovir, and other renally eliminated drugs and this may increase the risk of adverse reactions. Some examples of drugs that are eliminated by active tubular secretion include, but are not limited to, acyclovir, cidofovir, ganciclovir, valganciclovir, aminoglycosides (e.g., gentamicin), and high-dose or multiple NSAIDs [see *Warnings and Precautions (5.4)*].

7.5 Established and Other Potentially Significant Interactions

Table 5 provides a listing of established or potentially clinically significant drug interactions [see *Contraindications (4)*]. The drug interactions described are based on studies conducted with either GENVOYA, the components of GENVOYA (elvitegravir, cobicistat, emtricitabine, and tenofovir alafenamide) as individual agents and/or in combination, or are predicted drug interactions that may occur with GENVOYA [for

magnitude of interaction, see *Clinical Pharmacology (12.3)*]. The table includes potentially significant interactions but is not all inclusive.

Table 5 Established and Other Potentially Significant^a Drug Interactions: Alteration in Dose or Regimen May Be Recommended Based on Drug Interaction Studies or Predicted Interaction

Concomitant Drug Class: Drug Name	Effect on Concentration^b	Clinical Comment
Acid Reducing Agents: antacids* e.g., aluminum and magnesium hydroxide	↓ elvitegravir	Separate GENVOYA and antacid administration by at least 2 hours.
Alpha 1-adrenoreceptor antagonist: alfuzosin	↑ alfuzosin	Coadministration with alfuzosin is contraindicated due to potential for serious and/or life-threatening reactions such as hypotension.
Antiarrhythmics: e.g., amiodarone bepridil digoxin* disopyramide flecainide systemic lidocaine mexiletine propafenone quinidine	↑ antiarrhythmics ↑ digoxin	Caution is warranted and therapeutic concentration monitoring, if available, is recommended for antiarrhythmics when coadministered with GENVOYA.
Antibacterials: clarithromycin telithromycin	↑ clarithromycin ↑ telithromycin ↑ cobicistat	<u>Patients with CL_{cr} greater than or equal to 60 mL/minute:</u> No dosage adjustment of clarithromycin is required. <u>Patients with CL_{cr} between 50 mL/minute and 60 mL/minute:</u> The dosage of clarithromycin should be reduced by 50%.

<p>Anticoagulants: Direct Oral Anticoagulants (DOACs) apixaban rivaroxaban betrixaban dabigatran edoxaban</p> <p>warfarin</p>	<p>↑ apixaban</p> <p>↑ rivaroxaban</p> <p>↑ betrixaban ↑ dabigatran ↑ edoxaban</p> <p>Effect on warfarin unknown</p>	<p>Due to potentially increased bleeding risk, dosing recommendations for coadministration with GENVOYA depends on the apixaban dose. Refer to apixaban dosing instructions for coadministration with strong CYP3A and P-gp inhibitors in apixaban prescribing information.</p> <p>Coadministration of rivaroxaban with GENVOYA is not recommended because it may lead to an increased bleeding risk.</p> <p>Due to potentially increased bleeding risk, dosing recommendations for coadministration of betrixaban, dabigatran, or edoxaban with a P-gp inhibitor such as GENVOYA depends on DOAC indication and renal function. Refer to DOAC dosing instructions for coadministration with P-gp inhibitors in DOAC prescribing information.</p> <p>Monitor the international normalized ratio (INR) upon coadministration of warfarin with GENVOYA.</p>
<p>Anticonvulsants: carbamazepine* phenobarbital phenytoin</p> <p>oxcarbazepine</p> <p>ethosuximide</p>	<p>↓ elvitegravir ↓ cobicistat ↓ TAF</p> <p>↑ ethosuximide</p>	<p>Coadministration with carbamazepine, phenobarbital, or phenytoin is contraindicated due to potential for loss of therapeutic effect and development of resistance.</p> <p>Alternative anticonvulsants should be considered when GENVOYA is administered with oxcarbazepine.</p> <p>Clinical monitoring is recommended upon coadministration of ethosuximide with GENVOYA.</p>

<p>Antidepressants: Selective Serotonin Reuptake Inhibitors (SSRIs) e.g., paroxetine</p> <p>Tricyclic Antidepressants (TCAs) e.g., amitriptyline desipramine* imipramine nortriptyline bupropion</p> <p>trazodone</p>	<p>↑ SSRIs (except sertraline) ↑ TCAs ↑ trazodone</p>	<p>Careful dosage titration of the antidepressant and monitoring for antidepressant response are recommended when coadministered with GENVOYA.</p>
<p>Antifungals: itraconazole ketoconazole* voriconazole</p>	<p>↑ elvitegravir ↑ cobicistat ↑ itraconazole ↑ ketoconazole ↑ voriconazole</p>	<p>When administering with GENVOYA, the maximum daily dosage of ketoconazole or itraconazole should not exceed 200 mg per day.</p> <p>An assessment of benefit/risk ratio is recommended to justify use of voriconazole with GENVOYA.</p>
<p>Anti-gout: colchicine</p>	<p>↑ colchicine</p>	<p>GENVOYA is not recommended to be coadministered with colchicine to patients with renal or hepatic impairment.</p> <p><u>Treatment of gout-flares – coadministration of colchicine in patients receiving GENVOYA:</u> 0.6 mg (1 tablet) x 1 dose, followed by 0.3 mg (half tablet) 1 hour later. Treatment course to be repeated no earlier than 3 days.</p> <p><u>Prophylaxis of gout-flares – coadministration of colchicine in patients receiving GENVOYA:</u> If the original regimen was 0.6 mg twice a day, the regimen should be adjusted to 0.3 mg once a day. If the original regimen was 0.6 mg once a day, the regimen should be adjusted to 0.3 mg once every other day.</p> <p><u>Treatment of familial Mediterranean fever – coadministration of colchicine in patients receiving GENVOYA:</u> Maximum daily dosage of 0.6 mg (may be given as 0.3 mg twice a day).</p>
<p>Antimycobacterial: rifampin</p>	<p>↓ elvitegravir ↓ cobicistat ↓ TAF</p>	<p>Coadministration with rifampin is contraindicated due to potential for loss of therapeutic effect and development of resistance .</p>

rifabutin* rifapentine		Coadministration of GENVOYA with rifabutin or rifapentine is not recommended.
Antipsychotics: lurasidone	↑ lurasidone	Coadministration with lurasidone is contraindicated due to potential for serious and/or life-threatening reactions.
pimozide	↑ pimozide	Coadministration with pimozide is contraindicated due to potential for serious and/or life-threatening reactions such as cardiac arrhythmias.
quetiapine	↑ quetiapine	<u>Initiation of GENVOYA in patients taking quetiapine:</u> Consider alternative antiretroviral therapy to avoid increases in quetiapine exposure. If coadministration is necessary, reduce the quetiapine dose to 1/6 of the current dose and monitor for quetiapine-associated adverse reactions. Refer to the quetiapine prescribing information for recommendations on adverse reaction monitoring. <u>Initiation of quetiapine in patients taking GENVOYA:</u> Refer to the quetiapine prescribing information for initial dosing and titration of quetiapine.
Other antipsychotics e.g., perphenazine risperidone thioridazine	↑ antipsychotic	A decrease in dose of the antipsychotics that are metabolized by CYP3A or CYP2D6 may be needed when coadministered with GENVOYA.
Beta-Blockers: e.g., metoprolol timolol	↑ beta-blockers	Clinical monitoring is recommended and a dosage decrease of the beta blocker may be necessary when these agents are coadministered with GENVOYA.
Calcium Channel Blockers: e.g., amlodipine diltiazem felodipine nicardipine nifedipine verapamil	↑ calcium channel blockers	Caution is warranted and clinical monitoring is recommended upon coadministration of calcium channel blockers with GENVOYA.
Corticosteroids (all routes excluding cutaneous): e.g.,	↓ elvitegravir ↓ cobicistat ↑ corticosteroids	Coadministration with oral dexamethasone or other systemic corticosteroids that induce CYP3A may result in loss of therapeutic effect and development of resistance to elvitegravir. Consider alternative corticosteroids.

betamethasone budesonide ciclesonide dexamethasone fluticasone methylprednisolone mometasone prednisone triamcinolone		Coadministration with corticosteroids whose exposures are significantly increased by strong CYP3A inhibitors can increase the risk for Cushing's syndrome and adrenal suppression. Alternative corticosteroids including beclomethasone and prednisolone (whose PK and/or PD are less affected by strong CYP3A inhibitors relative to other studied steroids) should be considered, particularly for long-term use.
Endothelin Receptor Antagonists: bosentan	↑ bosentan	<u>Coadministration of bosentan in patients on GENVOYA:</u> In patients who have been receiving GENVOYA for at least 10 days, start bosentan at 62.5 mg once daily or every other day based upon individual tolerability. <u>Coadministration of GENVOYA in patients on bosentan:</u> Discontinue use of bosentan at least 36 hours prior to initiation of GENVOYA. After at least 10 days following the initiation of GENVOYA, resume bosentan at 62.5 mg once daily or every other day based upon individual tolerability.
Ergot Derivatives: dihydroergotamine ergotamine methylergonovine	↑ ergot derivatives	Coadministration is contraindicated due to potential for serious and/or life-threatening reactions such as acute ergot toxicity characterized by peripheral vasospasm and ischemia of the extremities and other tissues [see <i>Contraindications (4)</i>].
GI Motility Agent: cisapride	↑ cisapride	Coadministration is contraindicated due to potential for serious and/or life-threatening reactions such as cardiac arrhythmias.
Herbal Products: St. John's wort (<i>Hypericum perforatum</i>)	↓ elvitegravir ↓ cobicistat ↓ TAF	Coadministration is contraindicated due to potential for loss of therapeutic effect and development of resistance.
Hormonal Contraceptives: drospirenone/ethinyl estradiol* levonorgestrel norgestimate/ethinyl estradiol	↑ drospirenone ↑ norgestimate ↑ levonorgestrel ↓ ethinyl estradiol	Additional or alternative non-hormonal forms of contraception should be considered when estrogen based contraceptives are coadministered with GENVOYA. Plasma concentrations of drospirenone may be increased when coadministered with cobicistat-containing products. Clinical monitoring is recommended due to the potential for hyperkalemia. The effects of increases in the concentration of the progestational component norgestimate are not fully known and can include increased risk of insulin resistance, dyslipidemia, acne, and venous thrombosis. The potential risks and benefits associated with coadministration of norgestimate/ethinyl estradiol with GENVOYA should

		<p>be considered, particularly in patients who have risk factors for these events.</p> <p>The effect of GENVOYA on other hormonal contraceptives (e.g., contraceptive patch, contraceptive vaginal ring, or injectable contraceptives) or oral contraceptives containing progestogens other than drospirenone, levonorgestrel, or norgestimate has not been studied; therefore, alternative (non-hormonal) methods of contraception can be considered.</p>
<p>Immuno-suppressants: e.g., cyclosporine (CsA) sirolimus tacrolimus</p>	<p>↑ immuno-suppressants ↑ elvitegravir (with CsA) ↑ cobicistat (with CsA)</p>	<p>Therapeutic monitoring of the immunosuppressive agents is recommended upon coadministration with GENVOYA.</p> <p>Monitor for adverse events associated with GENVOYA when coadministered with cyclosporine.</p>
<p>Lipid-modifying Agents:</p> <p>HMG-CoA Reductase Inhibitors: lovastatin simvastatin atorvastatin</p> <p>Other Lipid-modifying Agents: lomitapide</p>	<p>↑ lovastatin ↑ simvastatin</p> <p>↑ atorvastatin</p> <p>↑ lomitapide</p>	<p>Coadministration with lovastatin or simvastatin is contraindicated due to potential for serious reactions such as myopathy including rhabdomyolysis.</p> <p>Initiate atorvastatin with the lowest starting dose of atorvastatin and titrate carefully while monitoring for safety (e.g., myopathy). Do not exceed a dosage of atorvastatin 20 mg daily.</p> <p>Coadministration with lomitapide is contraindicated due to potential for markedly increased transaminases.</p>
<p>Narcotic Analgesics: buprenorphine/ naloxone*</p> <p>fentanyl</p> <p>tramadol</p>	<p>↑ buprenorphine ↑ norbuprenorphine ↓ naloxone</p> <p>↑ fentanyl</p> <p>↑ tramadol</p>	<p>No dosage adjustment of buprenorphine/naloxone is required upon coadministration with GENVOYA. Patients should be closely monitored for sedation and cognitive effects.</p> <p>Careful monitoring of therapeutic and adverse effects of fentanyl (including potentially fatal respiratory depression) is recommended with coadministration.</p> <p>A dose decrease may be needed for tramadol with concomitant use.</p>
<p>Inhaled Beta Agonist: salmeterol</p>	<p>↑ salmeterol</p>	<p>Coadministration of salmeterol and GENVOYA is not recommended. Coadministration of salmeterol with GENVOYA may result in increased risk of cardiovascular adverse events associated with salmeterol, including QT prolongation, palpitations, and sinus tachycardia.</p>

<p>Phosphodiesterase -5 (PDE5) Inhibitors: sildenafil tadalafil vardenafil</p>	<p>↑ PDE5 inhibitors</p>	<p><u>Use of PDE-5 inhibitors for pulmonary arterial hypertension (PAH):</u> Coadministration of sildenafil with GENVOYA is contraindicated when used for treatment of PAH, due to potential for PDE-5 inhibitor associated adverse reactions, including hypotension, syncope, visual disturbances, and priapism. The following dose adjustments are recommended for the use of tadalafil with GENVOYA: <i>Coadministration of tadalafil in patients on GENVOYA:</i> In patients receiving GENVOYA for at least 1 week, start tadalafil at 20 mg once daily. Increase tadalafil dose to 40 mg once daily based upon individual tolerability. <i>Coadministration of GENVOYA in patients on tadalafil:</i> Avoid use of tadalafil during the initiation of GENVOYA. Stop tadalafil at least 24 hours prior to starting GENVOYA. After at least one week following initiation of GENVOYA, resume tadalafil at 20 mg once daily. Increase tadalafil dose to 40 mg once daily based upon individual tolerability.</p> <p><u>Use of PDE-5 inhibitors for erectile dysfunction:</u> Sildenafil at a single dose not exceeding 25 mg in 48 hours, vardenafil at a single dose not exceeding 2.5 mg in 72 hours, or tadalafil at a single dose not exceeding 10 mg in 72 hours can be used with increased monitoring for PDE-5 inhibitor associated with adverse events.</p>
---	--------------------------	--

Sedative/hypnotics : midazolam (oral) triazolam Other benzodiazepines: e.g., parenterally administered midazolam clorazepate diazepam estazolam flurazepam buspirone zolpidem	↑ midazolam ↑ triazolam ↑ sedatives/hypnotics	Coadministration with triazolam or orally administered midazolam is contraindicated due to potential for serious and/or life-threatening reactions such as prolonged or increased sedation or respiratory depression. Triazolam and orally administered midazolam are extensively metabolized by CYP3A. Coadministration of triazolam or orally administered midazolam with GENVOYA may cause large increases in the concentrations of these benzodiazepines. Coadministration of parenteral midazolam with GENVOYA should be done in a setting that ensures close clinical monitoring and appropriate medical management in case of respiratory depression and/or prolonged sedation. Dosage reduction for midazolam should be considered, especially if more than a single dose of midazolam is administered. With other sedative/hypnotics, dose reduction may be necessary and clinical monitoring is recommended.
---	--	---

* Indicates that a drug-drug interaction trial was conducted.

a. This table is not all inclusive.

b. ↑ = Increase, ↓ = Decrease

7.6 Drugs without Clinically Significant Interactions with GENVOYA

Based on drug interaction studies conducted with the components of GENVOYA, no clinically significant drug interactions have been observed when GENVOYA is combined with the following drugs: famciclovir, famotidine, ledipasvir, methadone, omeprazole, sertraline, sofosbuvir, velpatasvir, and voxilaprevir.

8 USE IN SPECIFIC POPULATIONS

8.1 Pregnancy

Pregnancy Exposure Registry

There is a pregnancy exposure registry that monitors pregnancy outcomes in individuals exposed to GENVOYA during pregnancy. Healthcare providers are encouraged to register patients by calling the Antiretroviral Pregnancy Registry (APR) at 1-800-258-4263.

Risk Summary

GENVOYA is not recommended during pregnancy [see *Dosage and Administration (2.5)*]. A literature report evaluating the pharmacokinetics of antiretrovirals during pregnancy demonstrated substantially lower exposures of elvitegravir and cobicistat in the second and third trimesters (see *Data*).

Prospective pregnancy data from the APR are not sufficient to adequately assess the risk of birth defects or miscarriage. However, elvitegravir, cobicistat, emtricitabine, and TAF use during pregnancy have been evaluated in a limited number of individuals as reported to the APR. Available data from the APR show no increase in the overall risk of major birth defects for emtricitabine or cobicistat compared with the background rate for major birth defects of 2.7% in a U.S. reference population of the Metropolitan Atlanta Congenital Defects Program (MACDP). The number of exposures to TAF and elvitegravir are insufficient to make a risk assessment compared to a reference population (*see Data*). The rate of miscarriage is not reported in the APR. In the U.S. general population, the estimated background risk of miscarriage in clinically recognized pregnancies is 15-20%.

In animal studies, no adverse developmental effects were observed when the components of GENVOYA were administered separately during the period of organogenesis at exposures up to 23 and 0.2 times (rat and rabbits, respectively: elvitegravir), 1.6 and 3.8 times (rats and rabbits, respectively: cobicistat), 60 and 108 times (mice and rabbits, respectively; emtricitabine) and equal to and 53 times (rats and rabbits, respectively; TAF) the exposure at the recommended daily dosage of these components in GENVOYA (*see Data*). Likewise, no adverse developmental effects were seen when elvitegravir or cobicistat was administered to rats through lactation at exposures up to 18 times or 1.2 times, respectively, the human exposure at the recommended therapeutic dose, and when emtricitabine was administered to mice through lactation at exposures up to approximately 60 times the exposure at the recommended daily dose. No adverse effects were observed in the offspring when TDF was administered through lactation at tenofovir exposures of approximately 14 times the exposure at the recommended daily dosage of GENVOYA.

Data

Human Data

A prospective study, reported in the literature, enrolled 30 pregnant women living with HIV who were receiving elvitegravir and cobicistat-based regimens in the second or third trimesters of pregnancy and through 6 to 12 weeks postpartum to evaluate the pharmacokinetics (PK) of antiretrovirals during pregnancy. Twenty-eight women completed the study through the postpartum period. Paired pregnancy/postpartum PK data were available from 14 and 24 women for the second and third trimesters, respectively. Exposures of elvitegravir and cobicistat were substantially lower during the second and third trimesters compared to postpartum. The proportion of pregnant women who were virologically suppressed was 77% in the second trimester, 92% in the third trimester, and 76% postpartum. No correlation was observed between viral suppression and elvitegravir exposure. HIV status was also assessed for infants: 25 were uninfected, 2 had indeterminate status, and no information was available for 3 infants.

Prospective reports from the APR of overall major birth defects in pregnancies exposed to the components of GENVOYA are compared with a U.S. background major birth defect rate. Methodological limitations of the APR include the use of

MACDP as the external comparator group. Limitations of using an external comparator include differences in methodology and populations, as well as confounding due to the underlying disease.

Elvitegravir:

The APR has received prospective reports of 5 birth defects among 180 first trimester exposures to elvitegravir-containing regimens during pregnancy resulting in live births. No birth defects were reported among 52 exposures during the second/third trimester. The number of exposures is insufficient to make a risk assessment compared to a reference population.

Cobicistat:

Based on prospective reports to the APR of 204 first trimester exposures to cobicistat-containing regimens during pregnancy, there was no increase in overall major birth defects with cobicistat compared with the background birth defect rate of 2.7% in the U.S. reference population of the MACDP. The prevalence of birth defects in live births was 2.5% (95% CI: 0.8% to 5.6%) with first trimester exposure to cobicistat-containing regimens. The 58 second/third trimester cobicistat exposures reported to the APR are insufficient to make a risk assessment.

Emtricitabine (FTC):

Based on prospective reports to the APR of exposures to emtricitabine-containing regimens during pregnancy resulting in live births (including over 2,700 exposed in the first trimester and over 1,200 exposed in the second/third trimester), there was no increase in overall major birth defects with FTC compared with the background birth defect rate of 2.7% in the U.S. reference population of the MACDP. The prevalence of birth defects in live births was 2.4% (95% CI: 1.9% to 3.1%) with first trimester exposure to FTC-containing regimens and 2.3% (95% CI: 1.5% to 3.3%) with second/third trimester exposure to emtricitabine-containing regimens.

Tenofovir Alafenamide (TAF):

The APR has received prospective reports of 3 birth defects among 56 first trimester exposures to TAF-containing regimens during pregnancy resulting in live births. No birth defects were reported among 29 exposures during the second/third trimester. The number of exposures is insufficient to make a risk assessment compared to a reference population.

Animal Data

Elvitegravir:

Elvitegravir was administered orally to pregnant rats (0, 300, 1000, and 2000 mg/kg/day) and rabbits (0, 50, 150, and 450 mg/kg/day) through organogenesis (on gestation days 7 through 17 and days 7 through 19, respectively). No significant toxicological effects were observed in embryo-fetal toxicity studies performed with elvitegravir in rats at exposures (AUC) approximately 23 times and in rabbits at

approximately 0.2 times the human exposures at the recommended daily dose. In a pre/postnatal developmental study, elvitegravir was administered orally to rats at doses of 0, 300, 1000, and 2000 mg/kg from gestation day 7 to day 20 of lactation. At doses of 2000 mg/kg/day of elvitegravir, neither maternal nor developmental toxicity was noted. Systemic exposures (AUC) at this dose were 18 times the human exposures at the recommended daily dose.

Cobicistat:

Cobicistat was administered orally to pregnant rats at doses of 0, 25, 50, 125 mg/kg/day on gestation day 6 to 17. Increases in post-implantation loss and decreased fetal weights were observed at a maternal toxic dose of 125 mg/kg/day. No malformations were noted at doses up to 125 mg/kg/day. Systemic exposures (AUC) at 50 mg/kg/day in pregnant females were 1.6 times higher than human exposures at the recommended daily dose.

In pregnant rabbits, cobicistat was administered orally at doses of 0, 20, 50, and 100 mg/kg/day during gestation days 7 to 20. No maternal or embryo/fetal effects were noted at the highest dose of 100 mg/kg/day. Systemic exposures (AUC) at 100 mg/kg/day were 3.8 times higher than human exposures at the recommended daily dose.

In a pre/postnatal developmental study in rats, cobicistat was administered orally at doses of 0, 10, 30, and 75 mg/kg from gestation day 6 to postnatal day 20, 21, or 22. At doses of 75 mg/kg/day of cobicistat, neither maternal nor developmental toxicity was noted. Systemic exposures (AUC) at this dose were 1.2 times the human exposures at the recommended daily dose.

Emtricitabine:

Emtricitabine was administered orally to pregnant mice (250, 500, or 1000 mg/kg/day) and rabbits (100, 300, or 1000 mg/kg/day) through organogenesis (on gestation days 6 through 15, and 7 through 19, respectively). No significant toxicological effects were observed in embryo-fetal toxicity studies performed with emtricitabine in mice at exposures (AUC) approximately 60 times higher and in rabbits at approximately 108 times higher than human exposures at the recommended daily dose.

In a pre/postnatal development study with emtricitabine, mice were administered doses up to 1000 mg/kg/day; no significant adverse effects directly related to drug were observed in the offspring exposed daily from before birth (*in utero*) through sexual maturity at daily exposures (AUC) of approximately 60 times higher than human exposures at the recommended daily dose.

Tenofovir Alafenamide (TAF):

TAF was administered orally to pregnant rats (25, 100, or 250 mg/kg/day) and rabbits (10, 30, or 100 mg/kg/day) through organogenesis (on gestation days 6 through 17, and 7 through 20, respectively). No adverse embryo-fetal effects were observed in rats and rabbits at TAF exposures similar to (rats) and approximately 53

(rabbits) times higher than the exposure in humans at the recommended daily dose of GENVOYA. TAF is rapidly converted to tenofovir; the observed tenofovir exposure in rats and rabbits were 59 (rats) and 93 (rabbits) times higher than human tenofovir exposures at the recommended daily doses. Since TAF is rapidly converted to tenofovir and lower tenofovir exposures in rats and mice were observed after TAF administration compared to TDF administration, a pre/postnatal development study in rats was conducted only with TDF. Doses up to 600 mg/kg/day were administered through lactation; no adverse effects were observed in the offspring on gestation day 7 [and lactation day 20] at tenofovir exposures of approximately 14 [21] times higher than the exposures in humans at the recommended daily dose of GENVOYA.

8.2 Lactation

Risk Summary

The Centers for Disease Control and Prevention recommend that HIV-infected mothers not breastfeed their infants to avoid risking postnatal transmission of HIV.

Based on published data, emtricitabine has been shown to be present in human breast milk; it is unknown if elvitegravir, cobicistat, and TAF are present in human breast milk. Elvitegravir and cobicistat are present in rat milk, and tenofovir has been shown to be present in the milk of lactating rats and rhesus monkeys after administration of TDF [see *Data*]. It is unknown if TAF is present in animal milk.

It is not known if GENVOYA affects milk production or has effects on the breastfed child. Because of the potential for 1) HIV transmission (in HIV-negative infants); 2) developing viral resistance (in HIV-positive infants); and 3) adverse reactions in a breastfed infant similar to those seen in adults, instruct mothers not to breastfeed if they are receiving GENVOYA.

Data

Animal Data

Elvitegravir: During the pre/postnatal developmental toxicology study at doses up to 2000 mg/kg/day, a mean elvitegravir milk to plasma ratio of 0.1 was measured 30 minutes after administration to rats on lactation day 14.

Cobicistat: During the pre/postnatal developmental toxicology study at doses up to 75 mg/kg/day, mean cobicistat milk to plasma ratio of up to 1.9 was measured 2 hours after administration to rats on lactation day 10.

Tenofovir Alafenamide: Studies in rats and monkeys have demonstrated that tenofovir is secreted in milk. During the pre/postnatal developmental toxicology study, tenofovir was excreted into the milk of lactating rats following oral administration of TDF (up to 600 mg/kg/day) at up to approximately 24% of the median plasma concentration in the highest dosed animals at lactation day 11. Tenofovir was excreted into the milk of lactating rhesus monkeys, following a single

subcutaneous (30 mg/kg) dose of tenofovir, at concentrations up to approximately 4% of plasma concentration resulting in exposure (AUC) of approximately 20% of plasma exposure.

8.4 Pediatric Use

The safety and effectiveness of GENVOYA for the treatment of HIV-1 infection was established in pediatric patients with body weight greater than or equal to 25 kg [see *Indications and Usage (1) and Dosage and Administration (2.2)*].

Use of GENVOYA in pediatric patients between the ages of 12 to less than 18 years and weighing at least 35 kg is supported by studies in adults and by a study in antiretroviral treatment-naïve HIV-1 infected pediatric subjects ages 12 to less than 18 years and weighing at least 35 kg (cohort 1 of Study 106, N=50). The safety and efficacy of GENVOYA in these pediatric subjects was similar to that in adults [see *Adverse Reactions (6.1), Clinical Pharmacology (12.3), and Clinical Studies (14.5)*].

Use of GENVOYA in pediatric patients weighing at least 25 kg is supported by studies in adults and by an open-label trial in virologically-suppressed pediatric subjects ages 6 to less than 12 years and weighing at least 25 kg, in which subjects were switched from their antiretroviral regimen to GENVOYA (cohort 2 of Study 106, N=23). The safety in these subjects through 24 weeks was similar to that in antiretroviral treatment-naïve adults with the exception of a decrease in mean change from baseline in CD4+ cell count [see *Adverse Reactions (6.1), Clinical Pharmacology (12.3), and Clinical Studies (14.5)*].

Safety and effectiveness of GENVOYA in pediatric patients less than 25 kg have not been established.

8.5 Geriatric Use

Clinical trials of GENVOYA included 97 subjects (80 receiving GENVOYA) aged 65 years and over. No differences in safety or efficacy have been observed between elderly subjects and adults between 18 and less than 65 years of age.

8.6 Renal Impairment

The pharmacokinetics, safety, and virologic and immunologic responses of GENVOYA in HIV-1 infected adult subjects with renal impairment (estimated creatinine clearance between 30 and 69 mL per minute by Cockcroft-Gault method) were evaluated in 248 subjects in an open-label trial, Study 112.

The pharmacokinetics, safety, virologic and immunologic responses of GENVOYA in HIV-1 infected adult subjects with ESRD (estimated creatinine clearance of less than 15 mL per minute by Cockcroft-Gault method) receiving chronic hemodialysis were evaluated in 55 subjects in an open-label trial, Study 1825 [see *Adverse Reactions (6.1) and Clinical Studies (14.4)*].

No dosage adjustment of GENVOYA is recommended in patients with estimated creatinine clearance greater than or equal to 30 mL per minute, or in adult patients with ESRD (estimated creatinine clearance below 15 mL per minute) who are receiving chronic hemodialysis. On days of hemodialysis, administer GENVOYA after completion of hemodialysis treatment [see *Dosage and Administration (2.2)*].

GENVOYA is not recommended in patients with severe renal impairment (estimated creatinine clearance of 15 to below 30 mL per minute), or in patients with ESRD who are not receiving chronic hemodialysis, as the safety of GENVOYA has not been established in these populations [see *Dosage and Administration (2.3)*, *Warnings and Precautions (5.4)* and *Clinical Pharmacology (12.3)*].

8.7 Hepatic Impairment

No dosage adjustment of GENVOYA is required in patients with mild (Child-Pugh Class A) or moderate (Child-Pugh Class B) hepatic impairment. GENVOYA has not been studied in patients with severe hepatic impairment (Child-Pugh Class C). Therefore, GENVOYA is not recommended for use in patients with severe hepatic impairment [see *Dosage and Administration (2.4)* and *Clinical Pharmacology (12.3)*].

10 OVERDOSAGE

No data are available on overdose of GENVOYA in patients. If overdose occurs, monitor the patient for evidence of toxicity. Treatment of overdose with GENVOYA consists of general supportive measures including monitoring of vital signs as well as observation of the clinical status of the patient.

Elvitegravir: Limited clinical experience is available at doses higher than the recommended dose of elvitegravir in GENVOYA. In one study, elvitegravir (administered with the CYP3A inhibitor cobicistat) equivalent to 2 times the therapeutic dose of 150 mg once daily for 10 days was administered to 42 healthy subjects. No severe adverse reactions were reported. The effects of higher doses are not known. As elvitegravir is highly bound to plasma proteins, it is unlikely that it will be significantly removed by hemodialysis or peritoneal dialysis.

Cobicistat: Limited clinical experience is available at doses higher than the recommended dose of cobicistat in GENVOYA. In two studies, a single dose of cobicistat 400 mg (2.7 times the dose in GENVOYA) was administered to a total of 60 healthy subjects. No severe adverse reactions were reported. The effects of higher doses are not known. As cobicistat is highly bound to plasma proteins, it is unlikely that it will be significantly removed by hemodialysis or peritoneal dialysis.

Emtricitabine: Limited clinical experience is available at doses higher than the recommended dose of emtricitabine in GENVOYA. In one clinical pharmacology study, single doses of emtricitabine 1200 mg (6 times the dose in GENVOYA) were administered to 11 subjects. No severe adverse reactions were reported. The effects of higher doses are not known.

Hemodialysis treatment removes approximately 30% of the emtricitabine dose over a 3-hour dialysis period starting within 1.5 hours of emtricitabine dosing (blood flow rate of 400 mL per minute and a dialysate flow rate of 600 mL per minute). It is not known whether emtricitabine can be removed by peritoneal dialysis.

Tenofovir alafenamide (TAF): Limited clinical experience is available at doses higher than the recommended dose of TAF in GENVOYA. A single dose of 125 mg TAF (12.5 times the dose in GENVOYA) was administered to 48 healthy subjects; no serious adverse reactions were reported. The effects of higher doses are unknown. Tenofovir is efficiently removed by hemodialysis with an extraction coefficient of approximately 54%.

11 DESCRIPTION

GENVOYA (elvitegravir, cobicistat, emtricitabine, and tenofovir alafenamide) is a fixed-dose combination tablet containing elvitegravir, cobicistat, emtricitabine, and tenofovir alafenamide for oral administration.

- Elvitegravir is an HIV-1 integrase strand transfer inhibitor.
- Cobicistat is a mechanism-based inhibitor of cytochrome P450 (CYP) enzymes of the CYP3A family.
- Emtricitabine, a synthetic nucleoside analog of cytidine, is an HIV nucleoside analog reverse transcriptase inhibitor (HIV NRTI).
- Tenofovir alafenamide, an HIV NRTI, is converted *in vivo* to tenofovir, an acyclic nucleoside phosphonate (nucleotide) analog of adenosine 5'-monophosphate.

Each tablet contains 150 mg of elvitegravir, 150 mg of cobicistat, 200 mg of emtricitabine, and 10 mg of tenofovir alafenamide (equivalent to 11.2 mg of tenofovir alafenamide fumarate). The tablets include the following inactive ingredients: croscarmellose sodium, hydroxypropyl cellulose, lactose monohydrate, magnesium stearate, microcrystalline cellulose, silicon dioxide, and sodium lauryl sulfate. The tablets are film-coated with a coating material containing FD&C Blue No. 2/indigo carmine aluminum lake, iron oxide yellow, polyethylene glycol, polyvinyl alcohol, talc, and titanium dioxide.

Elvitegravir: The chemical name of elvitegravir is 6-(3-chloro-2-fluorobenzyl)-1-[(2S)-1-hydroxy-3-methylbutan-2-yl]-7-methoxy-4-oxo-1,4-dihydroquinoline-3-carboxylic acid.

It has a molecular formula of $C_{23}H_{23}ClFNO_5$ and a molecular weight of 447.88. It has the following structural formula:

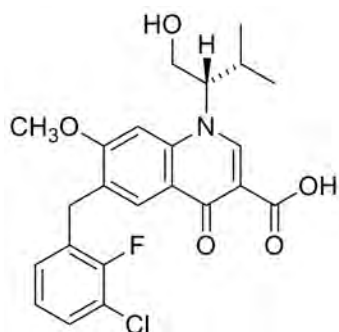

Elvitegravir is a white to pale yellow powder with a solubility of less than 0.3 micrograms per mL in water at 20 °C.

Cobicistat: The chemical name for cobicistat is 2,7,10,12-tetraazatridecanoic acid, 12-methyl-13-[2-(1-methylethyl)-4-thiazolyl]-9-[2-(4-morpholinyl)ethyl]-8,11-dioxo-3,6-bis(phenylmethyl)-, 5-thiazolylmethyl ester, (3*R*,6*R*,9*S*)-.

It has a molecular formula of $C_{40}H_{53}N_7O_5S_2$ and a molecular weight of 776.02. It has the following structural formula:

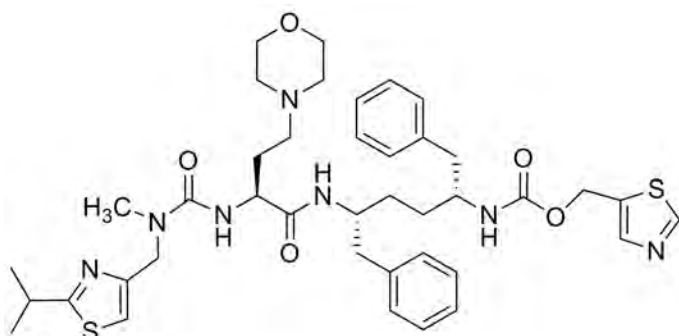

Cobicistat is adsorbed onto silicon dioxide. Cobicistat on silicon dioxide drug substance is a white to pale yellow powder with a solubility of 0.1 mg per mL in water at 20 °C.

Emtricitabine: The chemical name of emtricitabine is 4-amino-5-fluoro-1-(2*R*-hydroxymethyl-1,3-oxathiolan-5*S*-yl)-(1*H*)-pyrimidin-2-one. Emtricitabine is the (-)-enantiomer of a thio analog of cytidine, which differs from other cytidine analogs in that it has a fluorine in the 5 position.

It has a molecular formula of $C_8H_{10}FN_3O_3S$ and a molecular weight of 247.24. It has the following structural formula:

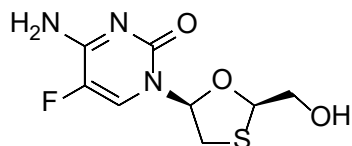

Emtricitabine is a white to off-white powder with a solubility of approximately 112 mg per mL in water at 25 °C.

Tenofovir alafenamide (TAF): The chemical name of tenofovir alafenamide fumarate drug substance is L-alanine, N-[(S)-[[(1R)-2-(6-amino-9H-purin-9-yl)-1-methylethoxy]methyl]phenoxyphosphinyl]-, 1-methylethyl ester, (2E)-2-butenedioate (2:1).

It has an empirical formula of $C_{21}H_{29}O_5N_6P \cdot \frac{1}{2}(C_4H_4O_4)$ and a formula weight of 534.5. It has the following structural formula:

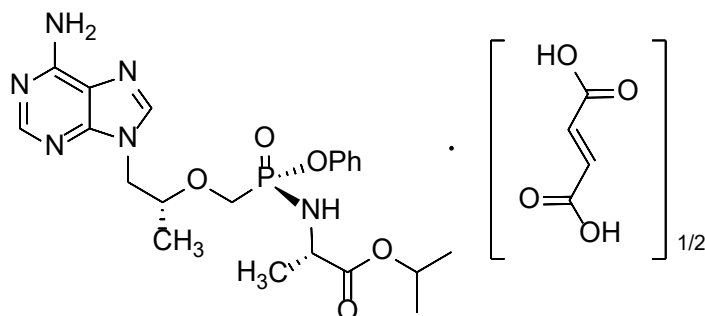

Tenofovir alafenamide fumarate is a white to off-white or tan powder with a solubility of 4.7 mg per mL in water at 20 °C.

12 CLINICAL PHARMACOLOGY

12.1 Mechanism of Action

GENVOYA is a fixed-dose combination of antiretroviral drugs elvitegravir (plus the CYP3A inhibitor cobicistat), emtricitabine, and tenofovir alafenamide [see *Microbiology* (12.4)].

12.2 Pharmacodynamics

Cardiac Electrophysiology

Thorough QT studies have been conducted for elvitegravir, cobicistat, and TAF. The effect of emtricitabine or the combination regimen GENVOYA on the QT interval is not known.

Elvitegravir: In a thorough QT/QTc study in 126 healthy subjects, elvitegravir (coadministered with 100 mg ritonavir) 125 mg and 250 mg (0.83 and 1.67 times the dose in GENVOYA) did not affect the QT/QTc interval and did not prolong the PR interval.

Cobicistat: In a thorough QT/QTc study in 48 healthy subjects, a single dose of cobicistat 250 mg and 400 mg (1.67 and 2.67 times the dose in GENVOYA) did not affect the QT/QTc interval. Prolongation of the PR interval was noted in subjects receiving cobicistat. The maximum mean (95% upper confidence bound) difference in PR from placebo after baseline-correction was 9.5 (12.1) msec for the 250 mg cobicistat dose and 20.2 (22.8) for the 400 mg cobicistat dose. Because the 150 mg cobicistat dose used in the GENVOYA fixed-dose combination tablet is lower than the lowest dose

studied in the thorough QT study, it is unlikely that treatment with GENVOYA will result in clinically relevant PR prolongation.

Tenofovir Alafenamide (TAF): In a thorough QT/QTc study in 48 healthy subjects, TAF at the therapeutic dose or at a supratherapeutic dose approximately 5 times the recommended therapeutic dose did not affect the QT/QTc interval and did not prolong the PR interval.

Effects on Serum Creatinine

The effect of cobicistat on serum creatinine was investigated in a Phase 1 study in subjects with an estimated creatinine clearance of at least 80 mL per minute (N=18) and with an estimated creatinine clearance of 50 to 79 mL per minute (N=12). A statistically significant change of estimated creatinine clearance from baseline was observed after 7 days of treatment with cobicistat 150 mg among subjects with an estimated creatinine clearance of at least 80 mL per minute (-9.9 ± 13.1 mL/min) and subjects with an estimated creatinine clearance between 50 and 79 mL per minute (-11.9 ± 7.0 mL per minute). These decreases in estimated creatinine clearance were reversible after cobicistat was discontinued. The actual glomerular filtration rate, as determined by the clearance of probe drug iohexol, was not altered from baseline following treatment of cobicistat among subjects with an estimated creatinine clearance of at least 50 mL per minute, indicating cobicistat inhibits tubular secretion of creatinine, reflected as a reduction in estimated creatinine clearance without affecting the actual glomerular filtration rate.

12.3 Pharmacokinetics

Absorption, Distribution, Metabolism, and Excretion

The pharmacokinetic (PK) properties of the components of GENVOYA are provided in Table 6. The multiple dose PK parameters of elvitegravir, cobicistat, emtricitabine, TAF and its metabolite tenofovir are provided in Table 7.

Table 6 Pharmacokinetic Properties of the Components of GENVOYA

	Elvitegravir	Cobicistat	Emtricitabine	TAF
Absorption				
T _{max} (h)	4	3	3	1
Effect of light meal (relative to fasting): AUC Ratio ^a	1.34 (1.19, 1.51)	1.03 (0.90, 1.17)	0.95 (0.91, 1.00)	1.15 (1.07, 1.24)
Effect of high fat meal (relative to fasting): AUC Ratio ^a	1.87 (1.66, 2.10)	0.83 (0.73, 0.95)	0.96 (0.92, 1.00)	1.18 (1.09, 1.26)
Distribution				
% Bound to human plasma proteins	~99	~98	<4	~80
Source of protein binding data	<i>Ex vivo</i>	<i>In vitro</i>	<i>In vitro</i>	<i>Ex vivo</i>
Blood-to-plasma ratio	0.73	0.5	0.6	1.0
Metabolism				
Metabolism	CYP3A (major) UGT1A1/3 (minor)	CYP3A (major) CYP2D6 (minor)	Not significantly metabolized	Cathepsin A ^b (PBMCs) CES1 (hepatocytes) CYP3A (minimal)
Elimination				
Major route of elimination	Metabolism	Metabolism	Glomerular filtration and active tubular secretion	Metabolism (>80% of oral dose)
t _{1/2} (h) ^c	12.9	3.5	10	0.51
% Of dose excreted in urine ^d	6.7	8.2	70	<1%
% Of dose excreted in feces ^d	94.8	86.2	13.7	31.7

PBMCs = peripheral blood mononuclear cells; CES1 = carboxylesterase 1.

- a. Values refer to geometric mean ratio in AUC [fed / fasted] and (90% confidence interval). Elvitegravir light meal=~373 kcal, 20% fat; GENVOYA light meal=~400 kcal, 20% fat; elvitegravir and GENVOYA high fat meal=~800 kcal, 50% fat. Based on the effect of food on elvitegravir, GENVOYA should be taken with food.
- b. *In vivo*, TAF is hydrolyzed within cells to form tenofovir (major metabolite), which is phosphorylated to the active metabolite, tenofovir diphosphate. *In vitro* studies have shown that TAF is metabolized to tenofovir by cathepsin A in PBMCs and macrophages; and by CES1 in hepatocytes. Upon coadministration with the moderate CYP3A inducer probe efavirenz, TAF exposure was not significantly affected.
- c. t_{1/2} values refer to median terminal plasma half-life. Note that the pharmacologically active metabolite, tenofovir diphosphate, has a half-life of 150–180 hours within PBMCs.
- d. Dosing in mass balance studies: elvitegravir (single dose administration of [¹⁴C] elvitegravir coadministered with 100 mg ritonavir); cobicistat (single dose administration of [¹⁴C] cobicistat after multiple dosing of cobicistat for six days); emtricitabine (single dose administration of [¹⁴C] emtricitabine after multiple dosing of emtricitabine for ten days); TAF (single dose administration of [¹⁴C] TAF).

Table 7 Multiple Dose Pharmacokinetic Parameters of Elvitegravir, Cobicistat, Emtricitabine, Tenofovir Alafenamide (TAF) and its

Metabolite Tenofovir Following Oral Administration of GENVOYA with Food in HIV-Infected Adults

Parameter Mean (CV%)	Elvitegravir ^a	Cobicistat ^a	Emtricitabine ^a	TAF ^b	Tenofovir ^c
C _{max} (microgram per mL)	2.1 (33.7)	1.5 (28.4)	2.1 (20.2)	0.16 (51.1)	0.02 (26.1)
AUC ₀₋₂₄ (microgram•hour per mL)	22.8 (34.7)	9.5 (33.9)	11.7 (16.6)	0.21 (71.8)	0.29 (27.4)
C _{trough} (microgram per mL)	0.29 (61.7)	0.02 (85.2)	0.10 (46.7)	NA	0.01 (28.5)

CV = Coefficient of Variation; NA = Not Applicable

a. From Intensive PK analysis in a Phase 2 trial in HIV infected adults, Study 102 (N=19).

b. From Population PK analysis in two trials of treatment-naïve adults with HIV-1 infection, Studies 104 and 111 (N=539).

c. From Population PK analysis in two trials of treatment-naïve adults with HIV-1 infection, Studies 104 and 111 (N=841).

Special Populations

Geriatric Patients

Pharmacokinetics of elvitegravir, cobicistat, emtricitabine and tenofovir have not been fully evaluated in the elderly (65 years of age and older). Age does not have a clinically relevant effect on exposures of TAF up to 75 years of age [see *Use in Specific Populations (8.5)*].

Pediatric Patients

Mean exposures of elvitegravir, cobicistat, and TAF achieved in 24 pediatric subjects aged 12 to less than 18 years who received GENVOYA in Study 106 were decreased compared to exposures achieved in treatment-naïve adults following administration of GENVOYA, but were overall deemed acceptable based on exposure-response relationships; emtricitabine exposure in adolescents was similar to that in treatment-naïve adults (Table 8).

Table 8 Multiple Dose Pharmacokinetic Parameters of Elvitegravir, Cobicistat, Emtricitabine, Tenofovir Alafenamide (TAF) and its

Metabolite Tenofovir Following Oral Administration of GENVOYA in HIV-Infected Pediatric Subjects Aged 12 to less than 18 Years^a

Parameter Mean (CV%)	Elvitegravir	Cobicistat	Emtricitabine	TAF	Tenofovir
C _{max} (microgram per mL)	2.2 (19.2)	1.2 (35.0)	2.3 (22.5)	0.17 (64.4)	0.02 (23.7)
AUC _{tau} (microgram•hour per mL)	23.8 (25.5)	8.2 ^b (36.1)	14.4 (23.9)	0.20 ^b (50.0)	0.29 ^b (18.8)
C _{trough} (microgram per mL)	0.30 (81.0)	0.03 ^c (180.0)	0.10 ^b (38.9)	NA	0.01 (21.4)

CV = Coefficient of Variation; NA = Not Applicable

a. From Intensive PK analysis in a trial in treatment-naïve pediatric subjects with HIV-1 infection, cohort 1 of Study 106 (N=24).

b. N=23

c. N=15

Exposures of the components of GENVOYA achieved in 23 pediatric subjects between the ages of 6 to less than 12 years who received GENVOYA in Study 106 were higher (20 to 80% for AUC) than exposures achieved in adults following the administration of GENVOYA; however, the increase was not considered clinically significant (Table 9) [see *Use in Specific Populations (8.4)*].

Table 9 Multiple Dose Pharmacokinetic Parameters of Elvitegravir, Cobicistat, Emtricitabine, Tenofovir Alafenamide (TAF) and its Metabolite Tenofovir Following Oral Administration of GENVOYA in HIV-Infected Pediatric Subjects Aged 6 to less than 12 Years^a

Parameter Mean (CV%)	Elvitegravir	Cobicistat	Emtricitabine	TAF	Tenofovir
C _{max} (microgram per mL)	3.1 (38.7)	2.1 (46.7)	3.4 (27.0)	0.31 (61.2)	0.03 (20.8)
AUC _{tau} (microgram•hour per mL)	33.8 ^b (57.8)	15.9 ^c (51.7)	20.6 ^b (18.9)	0.33 (44.8)	0.44 (20.9)
C _{trough} (microgram per mL)	0.37 (118.5)	0.1 (168.7)	0.11 (24.1)	NA	0.02 (24.9)

CV = Coefficient of Variation; NA = Not Applicable

a. From Intensive PK analysis in a trial in virologically-suppressed pediatric subjects with HIV-1 infection, cohort 2 of Study 106 (N=23).

b. N=22

c. N=20

Race, Gender

No clinically significant differences in pharmacokinetics of GENVOYA have been identified based on race or gender.

Patients with Renal Impairment

The pharmacokinetics of GENVOYA in HIV-1 infected subjects with mild or moderate renal impairment (estimated creatinine clearance between 30 and 69 mL per minute by Cockcroft-Gault method), and in HIV-1 infected subjects with ESRD (estimated creatinine clearance of less than 15 mL per minute by Cockcroft-Gault method) receiving chronic hemodialysis were evaluated in subsets of virologically suppressed subjects in respective open-label trials, Study 112 and Study 1825. The pharmacokinetics of elvitegravir, cobicistat, and tenofovir alafenamide were similar among healthy subjects, subjects with mild or moderate renal impairment, and subjects with ESRD receiving chronic hemodialysis; increases in emtricitabine and tenofovir exposures in subjects with renal impairment were not considered clinically relevant (Table 10).

Table 10 Pharmacokinetics of GENVOYA in HIV-Infected Adults with Renal Impairment as Compared to Subjects with Normal Renal Function

Estimated Creatinine Clearance ^a	AUC _{tau} (microgram·hour per mL) Mean (CV%)			
	≥90 mL per minute (N=18) ^b	60–89 mL per minute (N=11) ^c	30–59 mL per minute (N=18) ^d	<15 mL per minute (N=12) ^e
Emtricitabine	11.4 (11.9)	17.6 (18.2)	23.0 (23.6)	62.9 (48.0) ^f
Tenofovir	0.32 (14.9)	0.46 (31.5)	0.61 (28.4)	8.72 (39.4) ^g

a. By Cockcroft-Gault method.

b. From a Phase 2 study in HIV-infected adults with normal renal function.

c. These subjects from Study 112 had an estimated creatinine clearance between 60 and 69 mL per minute.

d. Study 112.

e. Study 1825; PK assessed prior to hemodialysis following 3 consecutive daily doses of GENVOYA.

f. N=11.

g. N=10.

Patients with Hepatic Impairment

Elvitegravir and Cobicistat: A study of the pharmacokinetics of elvitegravir (administered with the CYP3A inhibitor cobicistat) was performed in healthy subjects and subjects with moderate hepatic impairment (Child-Pugh Class B). No clinically relevant differences in elvitegravir or cobicistat pharmacokinetics were observed between subjects with moderate hepatic impairment and healthy subjects [see *Use in Specific Populations (8.7)*].

Emtricitabine: The pharmacokinetics of emtricitabine has not been studied in subjects with hepatic impairment; however, emtricitabine is not significantly metabolized by liver enzymes, so the impact of liver impairment should be limited.

Tenofovir Alafenamide (TAF): Clinically relevant changes in TAF and tenofovir pharmacokinetics were not observed in subjects with mild to moderate (Child-Pugh Class A and B) hepatic impairment [see *Use in Specific Populations (8.7)*].

Hepatitis B and/or Hepatitis C Virus Co-infection

Elvitegravir: Limited data from population pharmacokinetic analysis (N=24) indicated that hepatitis B and/or C virus infection had no clinically relevant effect on the exposure of elvitegravir (administered with the CYP3A inhibitor cobicistat).

Cobicistat: There were insufficient pharmacokinetic data in the clinical trials to determine the effect of hepatitis B and/or C virus infection on the pharmacokinetics of cobicistat.

Emtricitabine and Tenofovir Alafenamide (TAF): Pharmacokinetics of emtricitabine and TAF have not been fully evaluated in subjects coinfecting with hepatitis B and/or C virus.

Drug Interaction Studies

[see also *Contraindications (4)* and *Drug Interactions (7)*]

The drug-drug interaction studies described in Tables 11–14 were conducted with GENVOYA, elvitegravir (coadministered with cobicistat or ritonavir), cobicistat administered alone, or TAF (administered alone or coadministered with emtricitabine).

As GENVOYA should not be administered with other antiretroviral medications, information regarding drug-drug interactions with other antiretroviral agents is not provided.

The effects of coadministered drugs on the exposure of elvitegravir, emtricitabine, and TAF are shown in Table 11, Table 12, and Table 13 respectively. The effects of GENVOYA or its components on the exposure of coadministered drugs are shown in Table 14. For information regarding clinical recommendations, see *Drug Interactions (7)*.

Table 11 Drug Interactions: Changes in Pharmacokinetic Parameters for Elvitegravir in the Presence of the Coadministered Drug^a

Coadministered Drug	Dose of Coadministered Drug (mg)	Elvitegravir Dose (mg)	CYP3A Inhibitor Cobicistat or Ritonavir Dose (mg)	N	Mean Ratio of Elvitegravir Pharmacokinetic Parameters (90% CI); No effect = 1.00		
					C _{max}	AUC	C _{min}
Maximum strength antacid ^b	20 mL single dose given 4 hours before elvitegravir	50 single dose	Ritonavir 100 single dose	8	0.95 (0.84,1.07)	0.96 (0.88,1.04)	1.04 (0.93,1.17)
	20 mL single dose given 4 hours after elvitegravir			10	0.98 (0.88,1.10)	0.98 (0.91,1.06)	1.00 (0.90,1.11)
	20 mL single dose given 2 hours before elvitegravir			11	0.82 (0.74,0.91)	0.85 (0.79,0.91)	0.90 (0.82,0.99)
	20 mL single dose given 2 hours after elvitegravir			10	0.79 (0.71,0.88)	0.80 (0.75,0.86)	0.80 (0.73,0.89)
Atorvastatin	10 single dose	150 once daily ^c	Cobicistat 150 once daily ^c	16	0.91 (0.85,0.98)	0.92 (0.87,0.98)	0.88 (0.81,0.96)
Carbamazepine	200 twice daily	150 once daily	Cobicistat 150 once daily	12	0.55 (0.49,0.61)	0.31 (0.28,0.33)	0.03 (0.02,0.40)
Famotidine	40 once daily given 12 hours after elvitegravir	150 once daily	Cobicistat 150 once daily	10	1.02 (0.89,1.17)	1.03 (0.95,1.13)	1.18 (1.05,1.32)
	40 once daily given simultaneously with elvitegravir			16	1.00 (0.92,1.10)	1.03 (0.98,1.08)	1.07 (0.98,1.17)
Ketoconazole	200 twice daily	150 once daily	Ritonavir 100 once daily	18	1.17 (1.04,1.33)	1.48 (1.36,1.62)	1.67 (1.48,1.88)
Ledipasvir/Sofosbuvir	90/400 once daily	150 once daily ^c	Cobicistat 150 once daily ^c	30	0.98 (0.90,1.07)	1.11 (1.02,1.20)	1.46 (1.28,1.66)
Omeprazole	40 once daily given 2 hours before elvitegravir	50 once daily	Ritonavir 100 once daily	9	0.93 (0.83,1.04)	0.99 (0.91,1.07)	0.94 (0.85,1.04)
	20 once daily given 2 hours before elvitegravir	150 once daily	Cobicistat 150 once daily	11	1.16 (1.04,1.30)	1.10 (1.02,1.19)	1.13 (0.96,1.34)

Coadministered Drug	Dose of Coadministered Drug (mg)	Elvitegravir Dose (mg)	CYP3A Inhibitor Cobicistat or Ritonavir Dose (mg)	N	Mean Ratio of Elvitegravir Pharmacokinetic Parameters (90% CI); No effect = 1.00		
					C _{max}	AUC	C _{min}
	20 once daily given 12 hours after elvitegravir			11	1.03 (0.92,1.15)	1.05 (0.93,1.18)	1.10 (0.92,1.32)
Rifabutin	150 once every other day	150 once daily	Cobicistat 150 once daily	12	0.91 (0.84,0.99)	0.79 (0.74,0.85)	0.33 (0.27,0.40)
Rosuvastatin	10 single dose	150 once daily	Cobicistat 150 once daily	10	0.94 (0.83,1.07)	1.02 (0.91,1.14)	0.98 (0.83,1.16)
Sertraline	50 single dose	150 once daily ^c	Cobicistat 150 once daily ^c	19	0.88 (0.82,0.93)	0.94 (0.89,0.98)	0.99 (0.93,1.05)
Sofosbuvir/Velpatasvir	400/100 once daily	150 once daily ^c	Cobicistat 150 once daily ^c	24	0.87 (0.80,0.94)	0.94 (0.88,1.00)	1.08 (0.97,1.20)
Sofosbuvir/Velpatasvir/Voxilaprevir	400/100/100 + 100 Voxilaprevir ^d once daily	150 once daily ^c	Cobicistat 150 once daily ^c	29	0.79 (0.75,0.85)	0.94 (0.88,1.00)	1.32 (1.17,1.49)

- All interaction studies conducted in healthy volunteers.
- Maximum strength antacid contained 80 mg aluminum hydroxide, 80 mg magnesium hydroxide, and 8 mg simethicone, per mL.
- Study conducted with GENVOYA.
- Study conducted with additional voxilaprevir 100 mg to achieve voxilaprevir exposures expected in HCV-infected patients.

Table 12 Drug Interactions: Changes in Pharmacokinetic Parameters for Emtricitabine in the Presence of the Coadministered Drug^a

Coadministered Drug	Dose of Coadministered Drug (mg)	Emtricitabine Dose (mg)	N	Mean Ratio of Emtricitabine Pharmacokinetic Parameters (90% CI); No effect = 1.00		
				C _{max}	AUC	C _{min}
Famciclovir	500 single dose	200 single dose	12	0.90 (0.80,1.01)	0.93 (0.87,0.99)	NC

- All interaction studies conducted in healthy volunteers.

Table 13 Drug Interactions: Changes in Pharmacokinetic Parameters for Tenofovir Alafenamide (TAF) in the Presence of the Coadministered Drug^a

Coadministered Drug	Dose of Coadministered Drug (mg)	TAF Dose (mg)	N	Mean Ratio of TAF Pharmacokinetic Parameters (90% CI); No effect = 1.00		
				C _{max}	AUC	C _{min}
Cobicistat	150 once daily	8 once daily	12	2.83 (2.20,3.65)	2.65 (2.29,3.07)	NC
Ledipasvir/ Sofosbuvir	90/400 once daily	10 once daily ^b	30	0.90 (0.73,1.11)	0.86 (0.78,0.95)	NC
Sertraline	50 single dose	10 once daily ^b	19	1.00 (0.86,1.16)	0.96 (0.89,1.03)	NC
Sofosbuvir/ Velpatasvir	400/100 once daily	10 once daily ^b	24	0.80 (0.68,0.94)	0.87 (0.81,0.94)	NC
Sofosbuvir/ Velpatasvir/ Voxilaprevir	400/100/100 + 100 Voxilaprevir ^c once daily	10 once daily ^b	29	0.79 (0.68,0.92)	0.93 (0.85,1.01)	NC

NC = Not Calculated

- All interaction studies conducted in healthy volunteers.
- Study conducted with GENVOYA.
- Study conducted with additional voxilaprevir 100 mg to achieve voxilaprevir exposures expected in HCV-infected patients.

Table 14 Drug Interactions: Changes in Pharmacokinetic Parameters for Coadministered Drug in the Presence of GENVOYA or the Individual Components^a

Coadministered Drug	Dose of Coadministered Drug (mg)	Elvitegravir Dose (mg)	CYP3A Inhibitor Cobicistat Dose (mg)	FTC Dose (mg)	TAF Dose (mg)	N	Mean Ratio of Coadministered Drug Pharmacokinetic Parameters (90% CI); No effect = 1.00		
							C _{max}	AUC	C _{min}
Atorvastatin	10 single dose	150 once daily ^c	150 once daily ^c	200 once daily ^c	10 once daily ^c	16	2.32 (1.91,2.82)	2.60 (2.31,2.93)	NC
Buprenorphine	16 - 24 once daily	150 once daily	150 once daily	N/A	N/A	17	1.12 (0.98,1.27)	1.35 (1.18,1.55)	1.66 (1.43,1.93)
Norbuprenorphine							1.24 (1.03,1.49)	1.42 (1.22,1.67)	1.57 (1.31,1.88)
Carbamazepine	200 twice daily	150 once daily	150 once daily	N/A	N/A	12	1.40 (1.32,1.49)	1.43 (1.36,1.52)	1.51 (1.41,1.62)
Carbamazepine-10,11-epoxide							0.73 (0.70,0.78)	0.65 (0.63,0.66)	0.59 (0.57,0.61)
Desipramine	50 single dose	N/A	150 once daily	N/A	N/A	8	1.24 (1.08,1.44)	1.65 (1.36,2.02)	NC
Digoxin	0.5 single dose	N/A	150 once daily	N/A	N/A	22	1.41 (1.29,1.55)	1.08 (1.00,1.17)	NC
Famciclovir	500 single dose	N/A	N/A	200 single dose	N/A	12	0.93 (0.78,1.11)	0.91 (0.84,0.99)	N/A
Ledipasvir	90 once daily	150 once daily ^c	150 once daily ^c	200 once daily ^c	10 once daily ^c	30	1.65 (1.53,1.78)	1.79 (1.64,1.96)	1.93 (1.74,2.15)
Sofosbuvir	400 once daily						1.28 (1.13,1.47)	1.47 (1.35,1.59)	N/A
GS-331007 ^b							1.29 (1.24,1.35)	1.48 (1.44,1.53)	1.66 (1.60,1.73)
Naloxone	4–6 once daily	150 once daily	150 once daily	N/A	N/A	17	0.72 (0.61,0.85)	0.72 (0.59,0.87)	N/A
Norgestimate/ ethinyl estradiol ^d	0.180/0.215/ 0.250 norgestimate once daily	150 once daily ^d	150 once daily ^d	200 once daily ^d	N/A	13	2.08 (2.00,2.17)	2.26 (2.15,2.37)	2.67 (2.43,2.92)
	0.025 ethinyl estradiol once daily						0.94 (0.86,1.04)	0.75 (0.69,0.81)	0.56 (0.52,0.61)
Norgestromin	0.180/0.215/ 0.250 norgestimate once daily / 0.025 ethinyl	N/A	N/A	200 once daily ^e	25 once daily ^e	15	1.17 (1.07,1.26)	1.12 (1.07,1.17)	1.16 (1.08,1.24)
Norgestrel							1.10 (1.02,1.18)	1.09 (1.01,1.18)	1.11 (1.03,1.20)

Coadministered Drug	Dose of Coadministered Drug (mg)	Elvitegravir Dose (mg)	CYP3A Inhibitor Cobicistat Dose (mg)	FTC Dose (mg)	TAF Dose (mg)	N	Mean Ratio of Coadministered Drug Pharmacokinetic Parameters (90% CI); No effect = 1.00		
							C _{max}	AUC	C _{min}
Ethinyl estradiol	estradiol once daily						1.22 (1.15,1.29)	1.11 (1.07,1.16)	1.02 (0.92,1.12)
R-Methadone	80–120 daily	150 once daily	150 once daily	N/A	N/A	11	1.01 (0.91,1.13)	1.07 (0.96,1.19)	1.10 (0.95,1.28)
S-Methadone							0.96 (0.87,1.06)	1.00 (0.89,1.12)	1.02 (0.89,1.17)
Sertraline	50 single dose	150 once daily ^c	150 once daily ^c	200 once daily ^c	10 once daily ^c	19	1.14 (0.94,1.38)	0.93 (0.77,1.13)	N/A
Rifabutin	150 once every other day	150 once daily	150 once daily	N/A	N/A	12	1.09 (0.98,1.20) ^f	0.92 (0.83,1.03) ^f	0.94 (0.85,1.04) ^f
25-O-desacetyl-rifabutin						12	4.84 (4.09,5.74) ^f	6.25 (5.08,7.69) ^f	4.94 (4.04,6.04) ^f
Rosuvastatin	10 single dose	150 once daily	150 once daily	N/A	N/A	10	1.89 (1.48,2.42)	1.38 (1.14,1.67)	NC
Sofosbuvir	400 once daily	150 once daily ^c	150 once daily ^c	200 once daily ^c	10 once daily ^c	24	1.23 (1.07,1.42)	1.37 (1.24,1.52)	N/A
GS-331007 ^b							1.29 (1.25,1.33)	1.48 (1.43,1.53)	1.58 (1.52,1.65)
Velpatasvir	100 once daily						1.30 (1.17,1.45)	1.50 (1.35,1.66)	1.60 (1.44,1.78)
Sofosbuvir	400 once daily	150 once daily ^c	150 once daily ^c	200 once daily ^c	10 once daily ^c	29	1.27 (1.09,1.48)	1.22 (1.12,1.32)	NC
GS-331007 ^b							1.28 (1.25,1.32)	1.43 (1.39,1.47)	NC
Velpatasvir	100 once daily						0.96 (0.89,1.04)	1.16 (1.06,1.27)	1.46 (1.30,1.64)
Voxilaprevir	100 + 100 ^g once daily						1.92 (1.63,2.26)	2.71 (2.30,3.19)	4.50 (3.68,5.50)

FTC = emtricitabine; TAF = tenofovir alafenamide

N/A = Not Applicable; NC = Not Calculated

- All interaction studies conducted in healthy volunteers.
- The predominant circulating inactive metabolite of sofosbuvir.
- Study conducted with GENVOYA.
- Study conducted with STRIBILD.
- Study conducted with DESCOVY.
- Comparison based on rifabutin 300 mg once daily.
- Study conducted with additional voxilaprevir 100 mg to achieve voxilaprevir exposures expected in HCV-infected patients.

12.4 Microbiology

Mechanism of Action

Elvitegravir: Elvitegravir inhibits the strand transfer activity of HIV-1 integrase (integrase strand transfer inhibitor; INSTI), an HIV-1 encoded enzyme that is required for viral replication. Inhibition of integrase prevents the integration of HIV-1 DNA into host genomic DNA, blocking the formation of the HIV-1 provirus and propagation of the viral infection. Elvitegravir does not inhibit human topoisomerases I or II.

Cobicistat: Cobicistat is a selective, mechanism-based inhibitor of cytochromes P450 of the CYP3A subfamily. Inhibition of CYP3A-mediated metabolism by cobicistat enhances the systemic exposure of CYP3A substrates, such as elvitegravir, where bioavailability is limited and half-life is shortened by CYP3A-dependent metabolism.

Emtricitabine: Emtricitabine, a synthetic nucleoside analog of cytidine, is phosphorylated by cellular enzymes to form emtricitabine 5'-triphosphate. Emtricitabine 5'-triphosphate inhibits the activity of the HIV-1 reverse transcriptase by competing with the natural substrate deoxycytidine 5'-triphosphate and by being incorporated into nascent viral DNA which results in chain termination. Emtricitabine 5'-triphosphate is a weak inhibitor of mammalian DNA polymerases α , β , ϵ , and mitochondrial DNA polymerase γ .

Tenofovir Alafenamide (TAF): TAF is a phosphoramidate prodrug of tenofovir (2'-deoxyadenosine monophosphate analog). Plasma exposure to TAF allows for permeation into cells and then TAF is intracellularly converted to tenofovir through hydrolysis by cathepsin A. Tenofovir is subsequently phosphorylated by cellular kinases to the active metabolite tenofovir diphosphate. Tenofovir diphosphate inhibits HIV-1 replication through incorporation into viral DNA by the HIV reverse transcriptase, which results in DNA chain-termination.

Tenofovir has activity that is specific to human immunodeficiency virus and hepatitis B virus. Cell culture studies have shown that both emtricitabine and tenofovir can be fully phosphorylated when combined in cells. Tenofovir diphosphate is a weak inhibitor of mammalian DNA polymerases that include mitochondrial DNA polymerase γ and there is no evidence of mitochondrial toxicity in cell culture based on several assays including mitochondrial DNA analyses.

Antiviral Activity in Cell Culture

Elvitegravir, Cobicistat, Emtricitabine, and Tenofovir Alafenamide (TAF): The combination of elvitegravir, emtricitabine, and TAF was not antagonistic in cell culture combination antiviral activity assays and was not affected by the addition of cobicistat. In addition, elvitegravir, cobicistat, emtricitabine, and TAF were not antagonistic with a panel of representatives from the major classes of approved anti-HIV-1 agents (INSTIs, NNRTIs, NRTIs, and PIs).

Elvitegravir: The antiviral activity of elvitegravir against laboratory and clinical isolates of HIV-1 was assessed in T lymphoblastoid cell lines, monocyte/macrophage cells, and primary peripheral blood lymphocytes. The 50% effective concentrations (EC₅₀) ranged from 0.02 to 1.7 nM. Elvitegravir displayed antiviral activity in cell culture against HIV-1

clades A, B, C, D, E, F, G, and O (EC₅₀ values ranged from 0.1 to 1.3 nM) and activity against HIV-2 (EC₅₀ value of 0.53 nM). Elvitegravir did not show inhibition of replication of HBV or HCV in cell culture.

Cobicistat: Cobicistat has no detectable antiviral activity in cell culture against HIV-1, HBV, or HCV and does not antagonize the antiviral activity of elvitegravir, emtricitabine, or tenofovir.

Emtricitabine: The antiviral activity of emtricitabine against laboratory and clinical isolates of HIV-1 was assessed in T lymphoblastoid cell lines, the MAGI-CCR5 cell line, and primary peripheral blood mononuclear cells. The EC₅₀ values for emtricitabine were in the range of 0.0013–0.64 microM. Emtricitabine displayed antiviral activity in cell culture against HIV-1 clades A, B, C, D, E, F, and G (EC₅₀ values ranged from 0.007–0.075 microM) and showed strain specific activity against HIV-2 (EC₅₀ values ranged from 0.007–1.5 microM).

Tenofovir Alafenamide (TAF): The antiviral activity of TAF against laboratory and clinical isolates of HIV-1 subtype B was assessed in lymphoblastoid cell lines, PBMCs, primary monocyte/macrophage cells and CD4-T lymphocytes. The EC₅₀ values for TAF ranged from 2.0 to 14.7 nM.

TAF displayed antiviral activity in cell culture against all HIV-1 groups (M, N, O), including sub-types A, B, C, D, E, F, and G (EC₅₀ values ranged from 0.10 to 12.0 nM) and strain specific activity against HIV-2 (EC₅₀ values ranged from 0.91 to 2.63 nM).

Resistance

In Cell Culture

Elvitegravir: HIV-1 isolates with reduced susceptibility to elvitegravir have been selected in cell culture. Reduced susceptibility to elvitegravir was associated with the primary integrase substitutions T66A/I, E92G/Q, S147G, and Q148R. Additional integrase substitutions observed in cell culture selection included D10E, S17N, H51Y, F121Y, S153F/Y, E157Q, D232N, R263K, and V281M.

Emtricitabine: HIV-1 isolates with reduced susceptibility to emtricitabine have been selected in cell culture. Reduced susceptibility to emtricitabine was associated with M184V or I substitutions in HIV-1 RT.

Tenofovir Alafenamide (TAF): HIV-1 isolates with reduced susceptibility to TAF have been selected in cell culture. HIV-1 isolates selected by TAF expressed a K65R substitution in HIV-1 RT, sometimes in the presence of S68N or L429I substitutions; in addition, a K70E substitution in HIV-1 RT was observed.

In Clinical Trials

In Treatment-Naïve Subjects:

In a pooled analysis of antiretroviral-naïve subjects receiving GENVOYA in Studies 104 and 111, genotyping was performed on plasma HIV-1 isolates from

all subjects with HIV-1 RNA greater than 400 copies per mL at confirmed virologic failure, at Week 144, or at time of early study drug discontinuation. As of Week 144, the development of genotypic resistance to elvitegravir, emtricitabine, or TAF was observed in 12 of 22 subjects with evaluable resistance data from paired baseline and GENVOYA treatment-failure isolates (12 of 866 subjects [1.4%]) compared with 13 of 20 treatment-failure isolates from subjects with evaluable resistance data in the STRIBILD treatment group (13 of 867 subjects [1.5%]). Of the 12 subjects with resistance development in the GENVOYA group, the resistance-associated substitutions that emerged were M184V/I (N=11) and K65R/N (N=2) in reverse transcriptase and T66T/A/I/V (N=2), E92Q (N=4), E138K (N=1), Q148Q/R (N=1) and N155H (N=2) in integrase. Of the 13 subjects with resistance development in the STRIBILD group, the resistance-associated substitutions that emerged were M184V/I (N=9), K65R/N (N=4), and L210W (N=1) in reverse transcriptase and E92Q/V (N=4), E138K (N=3), Q148R (N=2), and N155H/S (N=3) in integrase. In both treatment groups, most subjects who developed substitutions associated with resistance to elvitegravir also developed emtricitabine resistance-associated substitutions. These genotypic resistance results were confirmed by phenotypic analyses.

In Virologically Suppressed Subjects:

Three virologic failure subjects were identified with emergent genotypic and phenotypic resistance to GENVOYA (all three with M184I or V and one with K219Q in reverse transcriptase; two with E92Q or G in integrase) out of 8 virologic failure subjects with resistance data in a clinical study of virologically-suppressed subjects who switched from a regimen containing emtricitabine/TDF and a third agent to GENVOYA (Study 109, N=959).

Cross-Resistance

No cross-resistance has been demonstrated for elvitegravir-resistant HIV-1 isolates and emtricitabine or tenofovir, or for emtricitabine- or tenofovir-resistant isolates and elvitegravir.

Elvitegravir: Cross-resistance has been observed among INSTIs. Elvitegravir-resistant viruses showed varying degrees of cross-resistance in cell culture to raltegravir depending on the type and number of amino acid substitutions in HIV-1 integrase. Of the primary elvitegravir resistance-associated substitutions tested (T66A/I/K, E92G/Q, T97A, S147G, Q148H/K/R, and N155H), all but three (T66I, E92G, and S147G) conferred greater than 1.5-fold reduced susceptibility to raltegravir (above the biological cutoff for raltegravir) when introduced individually into a wild-type virus by site-directed mutagenesis. Of the primary raltegravir resistance-associated substitutions (Y143C/H/R, Q148H/K/R, and N155H), all but Y143C/H conferred greater than 2.5-fold reductions in susceptibility to elvitegravir (above the biological cutoff for elvitegravir). Some viruses expressing elvitegravir or raltegravir resistance amino acid substitutions maintain susceptibility to dolutegravir.

Emtricitabine: Cross-resistance has been observed among NRTIs. Emtricitabine-resistant isolates harboring an M184V/I substitution in HIV-1 RT were cross-resistant to

lamivudine. HIV-1 isolates containing the K65R RT substitution, selected *in vivo* by abacavir, didanosine, and tenofovir, demonstrated reduced susceptibility to inhibition by emtricitabine.

Tenofovir Alafenamide (TAF): Tenofovir resistance substitutions, K65R and K70E, result in reduced susceptibility to abacavir, didanosine, emtricitabine, lamivudine, and tenofovir.

HIV-1 with multiple TAMs (M41L, D67N, K70R, L210W, T215F/Y, K219Q/E/N/R), or multinucleoside resistant HIV-1 with a T69S double insertion mutation or with a Q151M mutation complex including K65R, showed reduced susceptibility to TAF in cell culture.

13 NONCLINICAL TOXICOLOGY

13.1 Carcinogenesis, Mutagenesis, Impairment of Fertility

Elvitegravir

Long-term carcinogenicity studies of elvitegravir were carried out in mice (104 weeks) and in rats for up to 88 weeks (males) and 90 weeks (females). No drug-related increases in tumor incidence were found in mice at doses up to 2000 mg per kg per day alone or in combination with 25 mg per kg per day RTV at exposures 3- and 14 times, respectively, the human systemic exposure at the recommended daily dose of 150 mg. No drug-related increases in tumor incidence were found in rats at doses up to 2000 mg per kg per day at exposures 12- to 27 times, respectively in male and female, the human systemic exposure.

Elvitegravir was not genotoxic in the reverse mutation bacterial test (Ames test) and the rat micronucleus assay. In an *in vitro* chromosomal aberration test, elvitegravir was negative with metabolic activation; however, an equivocal response was observed without activation.

Elvitegravir did not affect fertility in male and female rats at approximately 16- and 30 times higher exposures (AUC), respectively, than in humans at the recommended 150 mg daily dose.

Fertility was normal in the offspring of rats exposed daily from before birth (*in utero*) through sexual maturity at daily exposures (AUC) of approximately 18 times higher than human exposures at the recommended 150 mg daily dose.

Cobicistat

In a long-term carcinogenicity study in mice, no drug-related increases in tumor incidence were observed at doses up to 50 and 100 mg/kg/day (males and females, respectively). Cobicistat exposures at these doses were approximately 7 (male) and 16 (females) times, respectively, the human systemic exposure at the therapeutic daily dose. In a long-term carcinogenicity study of cobicistat in rats, an increased incidence of follicular cell adenomas and/or carcinomas in the thyroid gland was observed at doses of 25 and 50 mg/kg/day in males, and at 30 mg/kg/day in females. The follicular cell

findings are considered to be rat-specific, secondary to hepatic microsomal enzyme induction and thyroid hormone imbalance, and are not relevant for humans. At the highest doses tested in the rat carcinogenicity study, systemic exposures were approximately 2 times the human systemic exposure at the recommended daily dose.

Cobicistat was not genotoxic in the reverse mutation bacterial test (Ames test), mouse lymphoma or rat micronucleus assays.

Cobicistat did not affect fertility in male or female rats at daily exposures (AUC) approximately 4 times higher than human exposures at the recommended 150 mg daily dose.

Fertility was normal in the offspring of rats exposed daily from before birth (*in utero*) through sexual maturity at daily exposures (AUC) of approximately 1.2 times higher than human exposures at the recommended 150 mg daily dose.

Emtricitabine

In long-term carcinogenicity studies of emtricitabine, no drug-related increases in tumor incidence were found in mice at doses up to 750 mg per kg per day (23 times the human systemic exposure at the therapeutic dose of 200 mg per day) or in rats at doses up to 600 mg per kg per day (28 times the human systemic exposure at the recommended dose).

Emtricitabine was not genotoxic in the reverse mutation bacterial test (Ames test), mouse lymphoma or mouse micronucleus assays.

Emtricitabine did not affect fertility in male rats at approximately 140 times or in male and female mice at approximately 60 times higher exposures (AUC) than in humans given the recommended 200 mg daily dose. Fertility was normal in the offspring of mice exposed daily from before birth (*in utero*) through sexual maturity at daily exposures (AUC) of approximately 60 times higher than human exposures at the recommended 200 mg daily dose.

Tenofovir Alafenamide (TAF)

Since TAF is rapidly converted to tenofovir and a lower tenofovir exposure in rats and mice is observed after TAF administration compared to TDF administration, carcinogenicity studies were conducted only with TDF. Long-term oral carcinogenicity studies of TDF in mice and rats were carried out at exposures up to approximately 10 times (mice) and 4 times (rats) those observed in humans at the 300 mg therapeutic dose of TDF for HIV-1 infection. The tenofovir exposure in these studies was approximately 167 times (mice) and 55 times (rat) those observed in humans after administration of GENVOYA treatment. At the high dose in female mice, liver adenomas were increased at tenofovir exposures 10 times (300 mg TDF) and 167 times (10 mg TAF in GENVOYA) that in humans. In rats, the study was negative for carcinogenic findings.

TAF was not genotoxic in the reverse mutation bacterial test (Ames test), mouse lymphoma or rat micronucleus assays.

There were no effects on fertility, mating performance or early embryonic development when TAF was administered to male rats at a dose equivalent to 155 times the human dose based on body surface area comparisons for 28 days prior to mating and to female rats for 14 days prior to mating through Day 7 of gestation.

13.2 Animal Toxicology and/or Pharmacology

Minimal to slight infiltration of mononuclear cells in the posterior uvea was observed in dogs with similar severity after three and nine month administration of TAF; reversibility was seen after a three month recovery period. At the NOAEL for eye toxicity, the systemic exposure in dogs was 5 (TAF) and 15 (tenofovir) times the exposure seen in humans at the recommended daily GENVOYA dosage.

14 CLINICAL STUDIES

14.1 Description of Clinical Trials

The efficacy and safety of GENVOYA were evaluated in the studies summarized in Table 15.

Table 15 Trials Conducted with GENVOYA in Subjects with HIV-1 Infection

Trial	Population	Study Arms (N)	Timepoint (Week)
Study 104 ^a Study 111 ^a	Treatment-naïve adults	GENVOYA (866) STRIBILD (867)	144
Study 109 ^b	Virologically-suppressed ^d adults	GENVOYA (959) ATRIPLA [®] or TRUVADA [®] +atazanavir+cobicistat or ritonavir or STRIBILD (477)	96
Study 112 ^c	Virologically-suppressed ^d adults with renal impairment ^e	GENVOYA (242)	144
Study 1825 ^c	Virologically-suppressed ^d adults with ESRD ^f receiving chronic hemodialysis	GENVOYA (55)	48
Study 106 (cohort 1) ^c	Treatment-naïve adolescents between the ages of 12 to less than 18 years (at least 35 kg)	GENVOYA (50)	48
Study 106 (cohort 2) ^c	Virologically-suppressed children between the ages of 6 to less than 12 years (at least 25 kg)	GENVOYA (23)	24

a. Randomized, double blind, active controlled trial.

- b. Randomized, open label, active controlled trial.
- c. Open label trial.
- d. HIV-1 RNA less than 50 copies per mL.
- e. Estimated creatinine clearance between 30 and 69 mL per minute by Cockcroft-Gault method.
- f. End stage renal disease (estimated creatinine clearance of less than 15 mL per minute by Cockcroft-Gault method).

14.2 Clinical Trial Results in HIV-1 Treatment-Naïve Subjects

In both Study 104 and Study 111, subjects were randomized in a 1:1 ratio to receive either GENVOYA (N=866) once daily or STRIBILD (elvitegravir 150 mg, cobicistat 150 mg, emtricitabine 200 mg, TDF 300 mg) (N=867) once daily. The mean age was 36 years (range 18–76), 85% were male, 57% were White, 25% were Black, and 10% were Asian. Nineteen percent of subjects identified as Hispanic/Latino. The mean baseline plasma HIV-1 RNA was 4.5 log₁₀ copies per mL (range 1.3–7.0) and 23% of subjects had baseline viral loads greater than 100,000 copies per mL. The mean baseline CD4+ cell count was 427 cells per mm³ (range 0–1360) and 13% had CD4+ cell counts less than 200 cells per mm³.

Pooled treatment outcomes of Studies 104 and 111 through Week 144 are presented in Table 16.

Table 16 Pooled Virologic Outcomes of Randomized Treatment in Studies 104 and 111 at Week 144^a in Treatment-Naive Subjects

	GENVOYA (N=866)	STRIBILD (N=867)
HIV-1 RNA < 50 copies/mL^b	84%	80%
HIV-1 RNA ≥ 50 copies/mL^c	5%	4%
No Virologic Data at Week 144 Window	11%	16%
Discontinued Study Drug Due to AE or Death ^d	2%	3%
Discontinued Study Drug Due to Other Reasons and Last Available HIV-1 RNA < 50 copies/mL ^e	9%	11%
Missing Data During Window but on Study Drug	1%	1%

- Week 144 window was between Day 966 and 1049 (inclusive).
- The primary endpoint was assessed at Week 48 and the virologic success rate was 92% in the GENVOYA group and 90% in the STRIBILD group, with a treatment difference of 2.0% (95% CI: -0.7% to 4.7%). The difference at Week 144 was primarily driven by discontinuations due to other reasons with last available HIV-1 RNA <50 copies/mL.
- Included subjects who had ≥50 copies/mL in the Week 144 window; subjects who discontinued early due to lack or loss of efficacy; subjects who discontinued for reasons other than an adverse event (AE), death or lack or loss of efficacy and at the time of discontinuation had a viral value of ≥ 50 copies/mL.
- Includes subjects who discontinued due to AE or death at any time point from Day 1 through the time window if this resulted in no virologic data on treatment during the specified window.
- Includes subjects who discontinued for reasons other than an AE, death or lack or loss of efficacy; e.g., withdrew consent, loss to follow-up, etc.

Treatment outcomes were similar across subgroups by age, sex, race, baseline viral load, and baseline CD4+ cell count.

In Studies 104 and 111, the mean increase from baseline in CD4+ cell count at Week 144 was 326 cells per mm³ in GENVOYA-treated subjects and 305 cells per mm³ in STRIBILD-treated subjects.

14.3 Clinical Trial Results in HIV-1 Virologically-Suppressed Subjects Who Switched to GENVOYA

In Study 109, the efficacy and safety of switching from ATRIPLA, TRUVADA plus atazanavir (given with either cobicistat or ritonavir), or STRIBILD to GENVOYA once daily were evaluated in a randomized, open-label trial of virologically-suppressed (HIV-1 RNA less than 50 copies per mL) HIV-1 infected adults (N=1436). Subjects must have been suppressed (HIV-1 RNA less than 50 copies per mL) on their baseline regimen for at least 6 months and had no known resistance-associated substitutions to any of the components of GENVOYA prior to study entry. Subjects were randomized in a 2:1 ratio to either switch to GENVOYA at baseline (N=959), or stay on their baseline antiretroviral regimen (N=477). Subjects had a mean age of 41 years (range 21–77), 89% were male, 67% were White, and 19% were Black. The mean baseline CD4+ cell count was 697 cells per mm³ (range 79–1951).

Subjects were stratified by prior treatment regimen. At screening, 42% of subjects were receiving TRUVADA plus atazanavir (given with either cobicistat or ritonavir), 32% were receiving STRIBILD, and 26% were receiving ATRIPLA.

Treatment outcomes of Study 109 through 96 weeks are presented in Table 17.

Table 17 Virologic Outcomes of Study 109 at Week 96^a in Virologically-Suppressed Subjects who Switched to GENVOYA

	GENVOYA (N=959)	ATRIPLA or TRUVADA+atazanavir +cobicistat or ritonavir or STRIBILD (N=477)
HIV-1 RNA < 50 copies/mL	93%	89%
HIV-1 RNA ≥ 50 copies/mL^b	2%	2%
No Virologic Data at Week 48 Window	5%	9%
Discontinued Study Drug Due to AE or Death ^c	1%	3%
Discontinued Study Drug Due to Other Reasons and Last Available HIV-1 RNA < 50 copies/mL ^d	3%	6%
Missing Data During Window but on Study Drug	1%	<1%

- Week 96 window was between Day 630 and 713 (inclusive).
- Included subjects who had ≥50 copies/mL in the Week 96 window; subjects who discontinued early due to lack or loss of efficacy; subjects who discontinued for reasons other than an adverse event (AE), death or lack or loss of efficacy and at the time of discontinuation had a viral value of ≥50 copies/mL.
- Includes subjects who discontinued due to AE or death at any time point from Day 1 through the time window if this resulted in no virologic data on treatment during the specified window.
- Includes subjects who discontinued for reasons other than an AE, death or lack or loss of efficacy; e.g., withdrew consent, loss to follow-up, etc.

Treatment outcomes were similar across subgroups receiving ATRIPLA, TRUVADA plus atazanavir (given with either cobicistat or ritonavir), or STRIBILD prior to randomization. In Study 109, the mean increase from baseline in CD4+ cell count at Week 96 was 60 cells per mm³ in GENVOYA-treated subjects and 42 cells per mm³ in subjects who stayed on their baseline regimen.

14.4 Clinical Trial Results in HIV-1 Infected Subjects with Renal Impairment

Study 112: Virologically-suppressed adults with renal impairment

In Study 112, the efficacy and safety of GENVOYA once daily were evaluated in an open-label clinical trial of 248 HIV-1 infected subjects with renal impairment (estimated creatinine clearance between 30 and 69 mL per minute by Cockcroft-Gault method). Of the 248 enrolled, 6 were treatment-naïve and 242 were virologically suppressed (HIV-1 RNA less than 50 copies per mL) for at least 6 months before switching to GENVOYA [see *Use in Specific Populations (8.6) and Clinical Pharmacology (12.3)*].

The mean age was 58 years (range 24–82), with 63 subjects (26%) who were 65 years of age or older. Seventy-nine percent were male, 63% were White, 18% were Black, and 14% were Asian. Thirteen percent of subjects identified as Hispanic/Latino. The mean baseline CD4+ cell count was 664 cells per mm³ (range 126–1813). At Week 144, 81% (197/242 virologically suppressed subjects) maintained HIV-1 RNA less than 50 copies per mL after switching to GENVOYA. All six treatment-naïve subjects were virologically suppressed at Week 144. Five subjects among the entire study population had virologic failure at Week 144.

Study 1825: Virologically-suppressed adults with end stage renal disease (ESRD) receiving chronic hemodialysis

In Study 1825, the efficacy and safety of GENVOYA once daily were evaluated in an open-label clinical trial of 55 virologically-suppressed (HIV-1 RNA less than 50 copies per mL for at least 6 months before switching to GENVOYA) HIV-1 infected subjects with ESRD (estimated creatinine clearance of less than 15 mL per minute by Cockcroft-Gault method) receiving chronic hemodialysis for at least 6 months [see *Use in Specific Populations (8.6) and Clinical Pharmacology (12.3)*].

Subjects had a mean age of 48 years (range 23–64), 76% were male, 82% were Black, 18% were White, and 15% identified as Hispanic/Latino. The mean baseline CD4+ cell count was 545 cell per mm³ (range 205–1473). At Week 48, 82% (45/55) maintained HIV-1 RNA less than 50 copies per mL after switching to GENVOYA. Two subjects had HIV-1 RNA ≥ 50 copies per mL by Week 48. Seven subjects discontinued the study drug due to AE or other reasons while suppressed. One subject did not have an HIV-1 RNA measurement at Week 48.

14.5 Clinical Trial Results in HIV-1 Infected Pediatric Subjects Between the Ages of 6 to Less than 18

In Study 106, an open-label, single arm trial the efficacy, safety, and pharmacokinetics of GENVOYA in HIV-1 infected pediatric subjects were evaluated in treatment-naïve adolescents between the ages of 12 to less than 18 years weighing at least 35 kg (N=50) and in virologically-suppressed children between the ages of 6 to less than 12 years weighing at least 25 kg (N=23).

Cohort 1: Treatment-naïve adolescents (12 to less than 18 years; at least 35 kg)

Subjects in cohort 1 treated with GENVOYA once daily had a mean age of 15 years (range 12-17); 44% were male, 12% were Asian, and 88% were Black. At baseline, mean plasma HIV-1 RNA was 4.6 log₁₀ copies per mL (22% had baseline plasma HIV-1 RNA greater than 100,000 copies per mL), median CD4+ cell count was 456 cells per mm³ (range: 95 to 1110), and median CD4+ percentage was 23% (range: 7% to 45%).

In subjects in cohort 1 treated with GENVOYA, 92% (46/50) achieved HIV-1 RNA less than 50 copies per mL at Week 48. The mean increase from baseline in CD4+ cell count at Week 48 was 224 cells per mm³. Three of 50 subjects had virologic failure at Week 48; no emergent resistance to GENVOYA was detected through Week 48.

Cohort 2: Virologically-suppressed children (6 to less than 12 years; at least 25 kg)

Subjects in cohort 2 treated with GENVOYA once daily had a mean age of 10 years (range: 8-11), a mean baseline weight of 31.6 kg, 39% were male, 13% were Asian, and 78% were Black. At baseline, median CD4+ cell count was 969 cells/mm³ (range: 603 to 1421), and median CD4% was 39% (range: 30% to 51%).

After switching to GENVOYA, 100% (23/23) of subjects in cohort 2 remained suppressed (HIV-1 RNA < 50 copies/mL) at Week 24. From a mean (SD) baseline CD4+ cell count of 966 (201.7), the mean change from baseline in CD4+ cell count was -150 cells/mm³ and the mean (SD) change in CD4% was -1.5% (3.7%) at Week 24. All subjects maintained CD4+ cell counts above 400 cells/mm³ [see *Adverse Reactions (6.1) and Pediatric Use (8.4)*].

16 HOW SUPPLIED/STORAGE AND HANDLING

GENVOYA tablets are green, capsule-shaped, film-coated tablets, debossed with “GSI” on one side of the tablet and the number “510” on the other side. Each bottle contains 30 tablets (NDC 61958-1901-1), a silica gel desiccant, polyester coil, and is closed with a child-resistant closure.

Store below 30 °C (86 °F).

- Keep container tightly closed.
- Dispense only in original container.

17 PATIENT COUNSELING INFORMATION

Advise the patient to read the FDA-approved patient labeling (Patient Information).

Drug Interactions

GENVOYA may interact with many drugs; therefore, advise patients to report to their healthcare provider the use of any other prescription or non-prescription medication or herbal products including St. John’s wort [see *Contraindications (4) and Drug Interactions (7)*].

Post-treatment Acute Exacerbation of Hepatitis B in Patients with HBV Co-Infection

Severe acute exacerbations of hepatitis B have been reported in patients who are coinfecting with HBV and HIV-1 and have discontinued products containing emtricitabine and/or TDF, and may likewise occur with discontinuation of GENVOYA [see *Warnings and Precautions (5.1)*]. Advise the patient to not discontinue GENVOYA without first informing their healthcare provider.

Immune Reconstitution Syndrome

Advise patients to inform their healthcare provider immediately of any symptoms of infection, as in some patients with advanced HIV infection (AIDS), signs and

symptoms of inflammation from previous infections may occur soon after anti-HIV treatment is started [see *Warnings and Precautions (5.3)*].

Renal Impairment

Advise patients to avoid taking GENVOYA with concurrent or recent use of nephrotoxic agents. Renal impairment including cases of acute renal failure has been reported in association with the use of tenofovir prodrugs [see *Warnings and Precautions (5.4)*].

Lactic Acidosis and Severe Hepatomegaly

Lactic acidosis and severe hepatomegaly with steatosis, including fatal cases, have been reported with use of drugs similar to GENVOYA. Advise patients that they should stop GENVOYA if they develop clinical symptoms suggestive of lactic acidosis or pronounced hepatotoxicity [see *Warnings and Precautions (5.5)*].

Missed Dosage

Inform patients that it is important to take GENVOYA on a regular dosing schedule with food and to avoid missing doses as it can result in development of resistance [see *Dosage and Administration (2.2)*].

Pregnancy

Advise patients that GENVOYA is not recommended during pregnancy and to alert their healthcare provider if they become pregnant while taking GENVOYA [see *Dosage and Administration (2.5)* and *Use in Specific Populations (8.1)*]. Inform patients that there is an antiretroviral pregnancy registry to monitor fetal outcomes of pregnant individuals exposed to GENVOYA [see *Use in Specific Populations (8.1)*].

Lactation

Instruct patients with HIV-1 infection not to breastfeed because HIV-1 can be passed to the baby in breast milk [see *Use in Specific Populations (8.2)*].

Manufactured and distributed by: Gilead Sciences, Inc. Foster City, CA 94404

Patient Information

GENVOYA® (jen-VOY-uh)
(elvitegravir, cobicistat, emtricitabine,
and tenofovir alafenamide)
tablets

Important: Ask your healthcare provider or pharmacist about medicines that should not be taken with GENVOYA.
For more information, see the section “What should I tell my healthcare provider before taking GENVOYA?”

What is the most important information I should know about GENVOYA?

GENVOYA can cause serious side effects, including:

- **Worsening of Hepatitis B infection. If you have hepatitis B virus (HBV) infection and take GENVOYA, your HBV may get worse (flare-up) if you stop taking GENVOYA. A “flare-up” is when your HBV infection suddenly returns in a worse way than before.**
 - Do not run out of GENVOYA. Refill your prescription or talk to your healthcare provider before your GENVOYA is all gone.
 - Do not stop taking GENVOYA without first talking to your healthcare provider.
If you stop taking GENVOYA, your healthcare provider will need to check your health often and do blood tests regularly for several months to check your HBV infection. Tell your healthcare provider about any new or unusual symptoms you may have after you stop taking GENVOYA.

For more information about side effects, see “What are the possible side effects of GENVOYA?”

What is GENVOYA?

GENVOYA is a prescription medicine that is used without other antiviral medicines to treat Human Immunodeficiency Virus-1 (HIV-1) in adults and children who weigh at least 55 pounds (25 kg):

- who have not received anti-HIV-1 medicines in the past, **or**
- to replace their current anti-HIV-1 medicines for people whose healthcare provider determines that they meet certain requirements.

HIV-1 is the virus that causes AIDS (Acquired Immune Deficiency Syndrome).

GENVOYA contains the prescription medicines elvitegravir, cobicistat, emtricitabine and tenofovir alafenamide.

It is not known if GENVOYA is safe and effective in children who weigh less than 55 pounds (25 kg).

Do not take GENVOYA if you also take a medicine that contains:

- alfuzosin hydrochloride
 - carbamazepine
 - cisapride
 - ergot-containing medicines, including:
 - dihydroergotamine mesylate
 - ergotamine tartrate
 - methylergonovine maleate
 - lomitapide
 - lovastatin
 - lurasidone
 - midazolam, when taken by mouth
 - phenobarbital
 - phenytoin
 - pimozone
 - rifampin
 - sildenafil, when used for treating the lung problem, pulmonary arterial hypertension
 - simvastatin
 - triazolam
- St. John’s wort (*Hypericum perforatum*) or a product that contains St. John’s wort.

What should I tell my healthcare provider before taking GENVOYA?

Before taking GENVOYA, tell your healthcare provider about all of your medical conditions, including if you:

- have liver problems, including hepatitis B infection
- have kidney problems
- are pregnant or plan to become pregnant.
 - It is not known if GENVOYA can harm your unborn baby.
 - GENVOYA should not be used during pregnancy because you may not have enough GENVOYA in your body during pregnancy.

- Tell your healthcare provider if you become pregnant during treatment with GENVOYA. Your healthcare provider may prescribe different medicines if you become pregnant while taking GENVOYA.

Pregnancy Registry: There is a pregnancy registry for women who take antiretroviral medicines during pregnancy. The purpose of this registry is to collect information about the health of you and your baby. Talk with your healthcare provider about how you can take part in this registry.

- are breastfeeding or plan to breastfeed. Do not breastfeed if you take GENVOYA.
 - You should not breastfeed if you have HIV-1 because of the risk of passing HIV-1 to your baby.
 - At least one of the medicines in GENVOYA can pass to your baby in your breast milk. It is not known if the other medicines in GENVOYA can pass into your breast milk.

Talk with your healthcare provider about the best way to feed your baby during treatment with GENVOYA.

Tell your healthcare provider about all the medicines you take, including prescription and over-the-counter medicines, vitamins, and herbal supplements.

Some medicines may interact with GENVOYA. Keep a list of your medicines and show it to your healthcare provider and pharmacist when you get a new medicine.

- You can ask your healthcare provider or pharmacist for a list of medicines that interact with GENVOYA.
- Do not start a new medicine without telling your healthcare provider. Your healthcare provider can tell you if it is safe to take GENVOYA with other medicines.

How should I take GENVOYA?

- Take GENVOYA exactly as your healthcare provider tells you to take it. GENVOYA is taken by itself (not with other HIV-1 medicines) to treat HIV-1 infection.
- Take GENVOYA 1 time each day with food.
- If you are on dialysis, take your daily dose of GENVOYA following dialysis.
- Do not change your dose or stop taking GENVOYA without first talking with your healthcare provider. Stay under a healthcare provider's care during treatment with GENVOYA.
- If you need to take a medicine for indigestion (antacid) that contains aluminum hydroxide, magnesium hydroxide, or calcium carbonate during treatment with GENVOYA, take it at least 2 hours before or after you take GENVOYA.
- Do not miss a dose of GENVOYA.
- When your GENVOYA supply starts to run low, get more from your healthcare provider or pharmacy. This is very important because the amount of virus in your blood may increase if the medicine is stopped for even a short time. The virus may develop resistance to GENVOYA and become harder to treat.
- If you take too much GENVOYA, call your healthcare provider or go to the nearest hospital emergency room right away.

What are the possible side effects of GENVOYA?

GENVOYA may cause serious side effects, including:

- **See “What is the most important information I should know about GENVOYA?”**
- **Changes in your immune system (Immune Reconstitution Syndrome)** can happen when you start taking HIV-1 medicines. Your immune system may get stronger and begin to fight infections that have been hidden in your body for a long time. Tell your healthcare provider right away if you start having any new symptoms after starting your HIV-1 medicine.
- **New or worse kidney problems, including kidney failure.** Your healthcare provider should do blood and urine tests to check your kidneys when starting and during treatment with GENVOYA. Your healthcare provider may tell you to stop taking GENVOYA if you develop new or worse kidney problems.
- **Too much lactic acid in your blood (lactic acidosis).** Too much lactic acid is a serious but rare medical emergency that can lead to death. Tell your healthcare provider right away if you get these symptoms: weakness or being more tired than usual, unusual muscle pain, being short of breath or fast breathing, stomach pain with nausea and vomiting, cold or blue hands and feet, feel dizzy or lightheaded, or a fast or abnormal heartbeat.
- **Severe liver problems.** In rare cases, severe liver problems can happen that can lead to death. Tell your healthcare provider right away if you get these symptoms: skin or the white part of your eyes turns yellow, dark “tea-colored” urine, light-colored stools, loss of appetite for several days or longer, nausea, or stomach-area pain.

The most common side effect of GENVOYA is nausea.

These are not all the possible side effects of GENVOYA.

Call your doctor for medical advice about side effects. You may report side effects to FDA at 1-800-FDA-1088.

How should I store GENVOYA?

- Store GENVOYA below 86°F (30°C).
- Keep GENVOYA in its original container.
- Keep the container tightly closed.

Keep GENVOYA and all medicines out of reach of children.

General information about the safe and effective use of GENVOYA.

Medicines are sometimes prescribed for purposes other than those listed in a Patient Information leaflet. Do not use GENVOYA for a condition for which it was not prescribed. Do not give GENVOYA to other people, even if they have the same symptoms you have. It may harm them. You can ask your healthcare provider or pharmacist for information about GENVOYA that is written for health professionals.

For more information, call 1-800-445-3235 or go to www.GENVOYA.com.

What are the ingredients in GENVOYA?

Active ingredients: elvitegravir, cobicistat, emtricitabine, and tenofovir alafenamide

Inactive ingredients: croscarmellose sodium, hydroxypropyl cellulose, lactose monohydrate, magnesium stearate, microcrystalline cellulose, silicon dioxide, and sodium lauryl sulfate. The tablets are film-coated with a coating material containing FD&C Blue No. 2/indigo carmine aluminum lake, iron oxide yellow, polyethylene glycol, polyvinyl alcohol, talc, and titanium dioxide.

Manufactured and distributed by: Gilead Sciences, Inc. Foster City, CA 94404

GENVOYA is a trademark of Gilead Sciences, Inc., or its related companies.

© 2018 Gilead Sciences, Inc. All rights reserved.

207561-GS-012

This Patient Information has been approved by the U.S. Food and Drug Administration

Revised: 12/2018

PRODUCT MONOGRAPH

Pr GILENYA[®]

Fingolimod capsules

0.25 mg and 0.5 mg fingolimod (as fingolimod hydrochloride)

Sphingosine 1-phosphate receptor modulator

Novartis Pharmaceuticals Canada Inc.
385 Bouchard Blvd.
Dorval, Quebec
H9S 1A9

Date of Preparation:
March 8, 2011

Date of Revision:
December 19, 2019

Submission Control No: 233920

GILENYA is a registered trademark

Table of Contents

PART I: HEALTH PROFESSIONAL INFORMATION.....	3
SUMMARY PRODUCT INFORMATION	3
INDICATIONS AND CLINICAL USE.....	3
CONTRAINDICATIONS	4
WARNINGS AND PRECAUTIONS.....	5
ADVERSE REACTIONS.....	26
DRUG INTERACTIONS	34
DOSAGE AND ADMINISTRATION	38
OVERDOSAGE	41
ACTION AND CLINICAL PHARMACOLOGY	42
STORAGE AND STABILITY	47
DOSAGE FORMS, COMPOSITION AND PACKAGING	47
PART II: SCIENTIFIC INFORMATION	48
PHARMACEUTICAL INFORMATION.....	48
CLINICAL TRIALS.....	48
DETAILED PHARMACOLOGY	55
TOXICOLOGY	57
REFERENCES	60
PART III: CONSUMER INFORMATION.....	62

PrGILENYA®

Fingolimod (as fingolimod hydrochloride)

PART I: HEALTH PROFESSIONAL INFORMATION

SUMMARY PRODUCT INFORMATION

Route of Administration	Dosage Form / Strength	Nonmedicinal Ingredients
Oral	Capsules / 0.25mg and 0.5 mg fingolimod (as fingolimod hydrochloride)	For the 0.5 mg: Magnesium stearate, mannitol, gelatin, titanium dioxide, yellow iron oxide. For the 0.25 mg: mannitol, hydroxypropylcellulose, hydroxypropylbetadex, magnesium stearate, gelatin, titanium dioxide, iron oxide yellow.

INDICATIONS AND CLINICAL USE

Adults: GILENYA (fingolimod) is indicated as monotherapy for the treatment of patients with the relapsing-remitting form of multiple sclerosis (MS) to reduce the frequency of clinical exacerbations and to delay the progression of physical disability. GILENYA is generally recommended in MS patients who have had an inadequate response to, or are unable to tolerate, one or more therapies for multiple sclerosis.

Pediatrics (10 years to < 18 years of age): GILENYA is indicated as monotherapy for the treatment of pediatric patients of 10 years to below 18 years of age with relapsing multiple sclerosis to reduce the frequency of clinical exacerbations. (see DOSAGE and ADMINISTRATION, Recommended Dose and Dosage Adjustment).

GILENYA should only be prescribed by neurologists who are experienced in the treatment of multiple sclerosis, and are knowledgeable of the efficacy and safety profile of GILENYA and are able to discuss benefits/risks with patients.

Pediatrics (< 10 years of age): Safety and efficacy of GILENYA in patients below the age of 10 have not been studied. GILENYA is not indicated in patients below 10 years of age.

Geriatrics (> 65 years of age): Clinical studies of GILENYA did not include sufficient numbers of patients aged 65 years and over to determine whether the safety and efficacy of GILENYA differs in elderly patients compared to younger patients. Physicians who choose to treat geriatric

patients should consider that treatment with GILENYA in the context of a greater frequency of reduced hepatic, renal, immune, pulmonary and cardiovascular function, other concomitant diseases and concomitant drug therapy warrants caution and may necessitate additional or more frequent monitoring (see CONTRAINDICATIONS and WARNINGS AND PRECAUTIONS).

CONTRAINDICATIONS

- Patients who are hypersensitive to fingolimod or to any ingredient in the formulation of GILENYA (fingolimod) or component of the container. For a complete listing, see the DOSAGE FORMS, COMPOSITION AND PACKAGING section of the product monograph.
- Patients with increased risk for opportunistic infections, including those who are immunocompromised due to treatment (e.g. antineoplastic, immunosuppressive or immunomodulating therapies, total lymphoid irradiation or bone marrow transplantation) or disease (e.g. immunodeficiency syndrome).
- Patients with severe active infections including active chronic bacterial, fungal or viral infections (e.g., hepatitis, tuberculosis).
- Patients with known active malignancies, except for patients with basal cell carcinoma.
- Patients with severe hepatic impairment (Child-Pugh Class C) (see WARNINGS AND PRECAUTIONS, Special Populations; WARNINGS AND PRECAUTIONS, Hepatic/Biliary/Pancreatic; and ACTION AND CLINICAL PHARMACOLOGY, Pharmacokinetics-Special Populations and Conditions).
- Patients who in the last 6 months had myocardial infarction, unstable angina pectoris, stroke/transient ischemic attack, decompensated heart failure (requiring inpatient treatment), or New York Heart Association Class III/IV heart failure.
- Patients with severe cardiac arrhythmias requiring anti-arrhythmic treatment with Class Ia or Class III anti-arrhythmic drugs (see WARNINGS AND PRECAUTIONS).
- Patients with second-degree Mobitz type II atrioventricular (AV) block or third-degree AV block, or sick-sinus syndrome, if they do not have a pacemaker (see WARNINGS AND PRECAUTIONS).
- Patients with a baseline QTc interval ≥ 500 msec (see WARNINGS AND PRECAUTIONS).
- Women (including female adolescents) who are pregnant or of childbearing potential not using effective contraception (see WARNINGS AND PRECAUTIONS). Pregnancy must be excluded before start of treatment as GILENYA may cause fetal harm.

WARNINGS AND PRECAUTIONS

Varicella vaccination

There have been very rare fatal cases of varicella zoster virus (VZV) infections in patients taking GILENYA (at recommended dose or higher doses used in clinical trials). These patients received prolonged concomitant corticosteroid use (more than 5 days) for treatment of multiple sclerosis relapses. Patients need to be assessed for their immunity to varicella (chickenpox) prior to GILENYA treatment. It is recommended that patients without a health care professional confirmed history of chickenpox or documentation of a full course of vaccination with varicella vaccine undergo antibody testing to varicella zoster virus (VZV) before initiating GILENYA therapy. A full course of vaccination for antibody-negative patients with varicella vaccine is recommended (if not contraindicated) prior to commencing treatment with GILENYA. If vaccinated, treatment with GILENYA should only be initiated 1 month after the patient has been vaccinated to allow full effect of vaccination to occur (see WARNINGS AND PRECAUTIONS, Herpetic infections).

SUMMARY OF IMPORTANT PRECAUTIONS TO BE TAKEN PRIOR TO INITIATING AND DURING TREATMENT WITH GILENYA

Refer to the WARNINGS AND PRECAUTIONS – Immune, Cardiovascular, Ophthalmologic, Hepatic/Biliary/Pancreatic, Special Populations, DRUG INTERACTIONS, and TOXICOLOGY sections for more complete information.

GILENYA should be used under the supervision of a neurologist experienced in the treatment of multiple sclerosis and familiar with the safety and efficacy of GILENYA. All patients should have an electrocardiogram (ECG) performed prior to the first dose and 6 hours after the first dose. Patients should be monitored closely for signs and symptoms of bradyarrhythmia, with hourly pulse and blood pressure measurements, for at least 6 hours after the first dose.

Immune system effects

GILENYA reduces circulating lymphocyte counts to 20-30% of baseline values via reversible retention in lymphoid organs and may increase the risk of infections.

- Delay the start of GILENYA in patients with severe active infection until resolved.
- Check complete blood count (CBC) before starting therapy if no recent (i.e. within 6 months or after discontinuation of prior therapy) result is available.
- Instruct patients to promptly report symptoms of infection during treatment and for two months after discontinuation.
- Check varicella-zoster virus (VZV) antibody status before starting therapy if there is no health care professional confirmed history of chicken pox or vaccination with varicella vaccine; if negative, vaccination is recommended, with a delay in treatment initiation for 1 month after vaccination to allow full effect of vaccination to occur.
- Co-administration of anti-neoplastic, immunosuppressive or immune-modulating therapies is not recommended due to the risk of additive immune system effects.

Cardiovascular effects

Initiation of GILENYA treatment results in reversible heart rate decrease and has also been associated with atrioventricular (AV) conduction delays, including isolated cases of spontaneously resolving complete AV block (see WARNINGS AND PRECAUTIONS, Bradyarrhythmia; ADVERSE REACTIONS Post Market Adverse Events).

Conditions when GILENYA should not be used

GILENYA should not be used in patients with a history or currently experiencing sino-atrial heart block, a history of recurrent syncope or symptomatic bradycardia, significant QT prolongation (QTc >470 msec in adult females, QTc >460 msec in pediatric females or >450 msec in adult and pediatric males) (see CONTRAINDICATIONS) or in patients with relevant risk factors for QT prolongation (e.g. hypokalemia, hypomagnesemia or congenital QT prolongation), due to the risk of serious cardiac rhythm disturbances.

- GILENYA should not be used in patients with a history of cardiac arrest, uncontrolled hypertension or severe untreated sleep apnea since significant bradycardia may be poorly

tolerated in these patients. (see CONTRAINDICATIONS)

- GILENYA should not be initiated in patients on concurrent therapy with beta-blockers, with heart-rate lowering calcium channel blockers or with other substances that may decrease heart rate because there is limited experience in situations of concomitant use and this may be associated with severe bradycardia and heart block. If treatment with GILENYA is considered necessary, advice from a cardiologist should be sought regarding a switch to a non heart-rate-lowering drug or for appropriate monitoring (e.g., at least overnight monitoring) during treatment initiation, if such a switch cannot be implemented.

First dose monitoring of fingolimod

- For all patients, obtain an electrocardiogram (ECG) and measure blood pressure prior to and 6-hours after the first dose of fingolimod.
- Monitor all patients for signs and symptoms of bradyarrhythmia, with hourly pulse and blood pressure measurements, for at least 6 hours after the first dose.
- If symptoms of bradyarrhythmia or atrioventricular (AV) block occur, initiate appropriate management, with continued monitoring (e.g., continuous ECG monitoring) until the symptoms have resolved.
- Should a patient require pharmacological intervention during the first dose observation period, continuous overnight monitoring (e.g., continuous ECG monitoring) in a medical facility should be instituted and the first dose monitoring strategy should be repeated when the second dose of fingolimod is administered.

The same precautions as for the first dose should be taken when patients are switched from the 0.25 mg to the 0.5 mg daily dose.

Extended monitoring, until the finding has resolved, is also required:

- if the heart rate at 6 hours post-dose is <45 bpm in adults, <55 bpm in pediatric patients aged 12 years and above, or <60 bpm in pediatric patients aged 10 to below 12 years, or is the lowest value post-dose,
or
- if the ECG at 6 hours after the first dose shows new-onset second-degree or higher grade AV block.

If the ECG at 6 hours after the first dose shows a QTc interval ≥ 500 msec patients should be monitored overnight.

Fingolimod may lead to an increase in blood pressure. Measure blood pressure regularly in all patients.

Ophthalmologic effects

GILENYA may cause macular edema with or without symptoms.

- An ophthalmic evaluation should be performed 3-4 months after treatment initiation in all patients, and at any time in any patient complaining of visual disturbances.

- Patients with diabetes mellitus or a history of uveitis are at increased risk of macular edema and should undergo an ophthalmic evaluation prior to initiating GILENYA therapy and have regular ophthalmic evaluations while receiving GILENYA therapy.

Hepatic effects

GILENYA may increase liver transaminases.

- Obtain transaminase and bilirubin levels prior to initiating treatment if no recent (i.e. within the last 6 months) result is available, every 3 months during the first year of treatment and periodically thereafter in the absence of symptoms or when symptoms suggestive of hepatic injury develop.

Pregnancy

- GILENYA is contraindicated in women (including female adolescents) who are pregnant or of childbearing potential not using effective contraception.
 - Women of childbearing potential, including adolescent females, their parents (or legal representatives), and caregivers must be counselled on the serious risk to the fetus and the need for effective contraception before treatment initiation, during, and for 2 months after treatment with GILENYA.
-

Cardiovascular

Initiation of GILENYA treatment is associated with decreased heart rate, PR interval prolongation and AV conduction delays, requiring patients to be monitored for at least 6 hours after receiving the first dose of GILENYA (see WARNINGS AND PRECAUTIONS - Bradyarrhythmia; - PR Interval Prolongation and Atrioventricular [AV] Block; - Monitoring During Re-initiation of Therapy Following Discontinuation). GILENYA is also associated with QTc interval prolongation (see WARNINGS AND PRECAUTIONS - QTc interval prolongation).

Bradyarrhythmia

Decreased heart rate

Initiation of GILENYA treatment results in a reversible decrease in heart rate. After the first dose, the heart rate decrease is maximal within 6 hours post-dosing. The heart rate returns to baseline progressively over approximately one month during chronic treatment (see ACTION AND CLINICAL PHARMACOLOGY, Pharmacodynamics – Heart rate and rhythm). Heart rates below 40 bpm in adults, and below 50 bpm in pediatric patients, were rarely observed (see ADVERSE REACTIONS). Adult patients who experienced bradycardia in controlled multiple sclerosis clinical trials were generally asymptomatic but some patients (0.5% receiving GILENYA 0.5 mg and 0.2% of patients receiving placebo) experienced mild to moderate symptoms, including hypotension, dizziness, fatigue, palpitations, dyspnea, arrhythmia, and/or chest pain or chest discomfort, which resolved within the first 24 hours of treatment (see ADVERSE REACTIONS, ECG Findings and Bradyarrhythmia; DRUG INTERACTIONS, Pharmacodynamic Interactions, and ACTIONS AND CLINICAL PHARMACOLOGY, Pharmacodynamics – Heart rate and

rhythm).

Conditions when GILENYA should not be used

Clinical trials in patients with multiple sclerosis excluded patients with several cardiovascular conditions and/or risk factors. Due to limited experience in patients with cardiovascular conditions and/or risk factors and the known effects of GILENYA on heart rate and cardiac conduction, GILENYA should not be used in patients with the following conditions.

- GILENYA should not be used in patients with a history or presence of sino-atrial heart block, a history of recurrent syncope or symptomatic bradycardia, or significant QT prolongation (QTc >470 msec in adult females, QTc >460 msec in pediatric females or >450 msec in adult and pediatric males) (see CONTRAINDICATIONS) or in patients with relevant risk factors for QT prolongation (e.g. hypokalemia, hypomagnesemia or congenital QT prolongation), due to the risk of serious cardiac rhythm disturbances. In patients for whom GILENYA is not contraindicated, if a decision is made to undertake treatment, such patients should be evaluated by a cardiologist prior to initiation of treatment, to assess suitability and to determine the most appropriate monitoring strategy, which should be at least overnight.
- GILENYA should not be used in patients with a history of cardiac arrest, uncontrolled hypertension or severe untreated sleep apnea because significant bradycardia may be poorly tolerated in these patients (see CONTRAINDICATIONS). In patients for whom GILENYA is not contraindicated, if a decision is made to undertake treatment, such patients should be evaluated by a cardiologist prior to initiation of treatment, to assess suitability and to determine the most appropriate monitoring, strategy which should be at least overnight.
- GILENYA has not been studied in patients with arrhythmias requiring treatment with Class Ia (e.g. quinidine, disopyramide) or Class III (e.g. amiodarone, sotalol) antiarrhythmic drugs. Class Ia and Class III antiarrhythmic drugs have been associated with cases of torsades de pointes in patients with bradycardia (see CONTRAINDICATIONS).
- There is limited experience with GILENYA in patients receiving concurrent therapy with beta blockers, heart-rate lowering calcium channel blockers (such as verapamil or diltiazem), or other substances that may decrease heart rate (e.g. digoxin, cholinesterase inhibitors or pilocarpine). Since the initiation of GILENYA treatment is also associated with bradycardia (see “Decreased Heart Rate”), concomitant use of these substances during GILENYA initiation may be associated with severe bradycardia and heart block. Because of the potential additive effect on heart rate, GILENYA should not be initiated in patients who are concurrently treated with these substances. If treatment with GILENYA is considered necessary, advice from a cardiologist should be sought regarding a switch to drugs that do not lower heart rate or for appropriate monitoring (e.g., at least overnight monitoring) during treatment initiation, if the heart-rate-lowering drugs cannot be discontinued (see DRUG INTERACTIONS).

For patients with any of the above conditions, treatment should only be considered if the expected benefits outweigh the known risks.

First dose monitoring of fingolimod

- For all patients, obtain an ECG and measure blood pressure prior to and 6-hours after the first dose.
- Monitor all patients for signs and symptoms of bradyarrhythmia, with hourly pulse and blood pressure measurements, for at least 6 hours after the first dose.
- If symptoms of bradyarrhythmia or AV block occur, initiate appropriate management, with continued monitoring (e.g., continuous ECG monitoring) until the symptoms have resolved.
- Should a patient require pharmacological intervention during the first-dose observation period, continuous overnight monitoring (e.g., continuous ECG monitoring) in a medical facility should be instituted and the first-dose monitoring strategy should be repeated when the second dose of fingolimod is administered.

The same precautions as for the first dose should be taken when patients are switched from the 0.25 mg to the 0.5 mg daily dose.

Extended monitoring, until the finding has resolved, is also required

- if the heart rate at 6 hours post-dose is <45 bpm in adults, <55 bpm in pediatric patients aged 12 years and above, or <60 bpm in pediatric patients aged 10 to below 12 years, or is the lowest value post-dose (suggesting that the maximum pharmacodynamic effect on the heart has not yet manifested)
or
- if the ECG at 6 hours after the first dose shows new-onset second-degree or higher grade AV block.

If the ECG at 6 hours after the first dose shows a QTc interval ≥ 500 msec patients should be monitored overnight.

PR Interval Prolongation and Atrioventricular (AV) Block

Initiation of GILENYA treatment has been associated with PR interval prolongation and AV conduction delays. The maximum increase in the PR interval occurs at about 6 h post-dosing. In Phase III controlled clinical trials in adults, the incidence of first degree AV block on ECG at 6 h after the first dose was 4.7% of patients receiving GILENYA 0.5 mg and 1.5% of patients receiving placebo, while the incidence of 2nd-degree AV block Mobitz type 1 was 0.2% for GILENYA 0.5 mg and 0 for placebo. On Holter monitoring 2nd-degree AV block, Mobitz type 1 (Wenckebach), was reported in 3.4% of patients receiving GILENYA 0.5 mg and 2% of patients on placebo, while 2:1 AV block was reported in 1.7% of patients receiving GILENYA 0.5 mg, but not in any patients receiving placebo. The conduction abnormalities typically were transient, asymptomatic, and resolved within the first 24-hours on treatment. Isolated cases of transient, spontaneously resolving complete AV block have been reported during post-marketing use of GILENYA (see ADVERSE REACTIONS, ECG Findings and Bradyarrhythmia; DRUG INTERACTIONS, Pharmacodynamic

Interactions; ACTION AND CLINICAL PHARMACOLOGY, Pharmacodynamics – Heart rate and rhythm).

Monitoring During Re-initiation of Therapy Following Discontinuation

If fingolimod therapy is discontinued for more than 2 weeks, after the first month of treatment, the effects on heart rate and AV conduction may recur on reintroduction of fingolimod treatment and the same precautions as for the first dose should apply (i.e., monitor for at least 6 hours after the first dose). Within the first 2 weeks of treatment, first-dose procedures are recommended after an interruption of one day or more. During weeks 3 and 4 of treatment, first dose procedures are recommended after a treatment interruption of more than 7 days.

QTc Prolongation

GILENYA is associated with QTc interval prolongation (see ADVERSE REACTIONS, ECG Findings; DRUG INTERACTIONS, Pharmacodynamic Interactions; and ACTIONS AND CLINICAL PHARMACOLOGY, Pharmacodynamics – Thorough QT Study).

In a thorough QT interval study of doses of 1.25 mg or 2.5 mg fingolimod at steady-state, when a negative chronotropic effect of fingolimod was still present, fingolimod treatment resulted in a prolongation of QTcI, with the upper limit of the 90% CI ≤ 13.0 ms. In the multiple sclerosis studies, clinically relevant effects on prolongation of the QTc-interval have not been observed. However, patients at risk for QT prolongation were excluded from clinical studies.

Since initiation of GILENYA treatment results in decreased heart rate, and therefore a prolongation of the QT interval, GILENYA should not be used in patients with significant QT prolongation (QTc >470 msec in adult females, QTc >460 msec in pediatric females or >450 msec in adult or pediatric males) or in patients with relevant risk factors for QT prolongation (e.g., hypokalemia, hypomagnesemia or congenital QT prolongation). If a decision is made to undertake treatment, such patients should be evaluated by a cardiologist prior to initiation of treatment, to assess suitability and to determine the most appropriate monitoring, which should be at least overnight.

GILENYA has not been studied in patients treated with drugs that prolong the QT interval. Because the risk of QT interval prolongation is expected to be greater in patients who receive concomitant treatment with other drugs that prolong the QT interval, the use of GILENYA with such drugs should be avoided. If a decision is made to undertake treatment such patients should be evaluated by a cardiologist prior to initiation of treatment, to assess suitability and to determine the most appropriate monitoring, which should be at least overnight.

Many drugs that cause QTc prolongation are suspected to increase the risk of torsade de pointes, a polymorphic ventricular tachyarrhythmia. Torsade de pointes may be asymptomatic or experienced by the patient as dizziness, palpitations, syncope, or seizures. If sustained, torsade de pointes can progress to ventricular fibrillation and sudden cardiac death.

Blood pressure effects

In multiple sclerosis clinical trials, patients treated with GILENYA 0.5 mg had an average increase of approximately 2 mmHg in systolic pressure, and approximately 1 mmHg in diastolic pressure, first detected after approximately 1 month of treatment initiation, and persisting with continued treatment. In controlled studies involving 854 multiple sclerosis adult patients on GILENYA 0.5 mg and 511 multiple sclerosis patients on placebo, hypertension was reported as an adverse reaction in 5% of patients on GILENYA 0.5 mg and in 3% of patients on placebo. Blood pressure should be monitored during treatment with GILENYA.

Immune

Infections

A core pharmacodynamic effect of GILENYA is a dose-dependent reduction of peripheral lymphocyte count to 20-30% of baseline values. This is due to the reversible sequestration of lymphocytes in lymphoid tissues. Because elimination of fingolimod after discontinuation of GILENYA may take up to 2 months, recovery of peripheral lymphocyte counts to baseline values is gradual (see ACTION AND CLINICAL PHARMACOLOGY, Pharmacodynamics). GILENYA may therefore increase the risk of infections, including opportunistic infections (see ADVERSE REACTIONS) during treatment and for up to 2 months after discontinuation of treatment. Continue monitoring for infections during this period.

GILENYA is contraindicated in patients at an increased risk of opportunistic infections and in patients with severe active infections including active chronic bacterial, fungal or viral infections (see CONTRAINDICATIONS).

Before initiating and during treatment with GILENYA, the following precautions should be taken:

- Obtain a CBC before initiating treatment if no recent (i.e. within 6 months or after discontinuation of prior therapy) result is available. Treatment with GILENYA should not be initiated when lymphocyte counts are consistently below the normal range.
- Treatment should not be initiated when there are signs and symptoms of a severe active bacterial, fungal or viral infection. Instruct patients to promptly report symptoms or signs suggestive of any infection, during and for up to 2 months after discontinuation of treatment, to facilitate early diagnosis and initiation of appropriate treatments (see WARNINGS AND PRECAUTIONS, Patient Counseling Information).
- Determine immunization status for VZV. Patients need to be assessed for their immunity to varicella (chickenpox) prior to GILENYA treatment. It is recommended that patients without a health care professional confirmed history of chickenpox or documentation of a full course of vaccination with varicella vaccine undergo antibody testing to varicella zoster virus (VZV) before initiating GILENYA therapy. A full course of vaccination for antibody-negative patients

with varicella vaccine is recommended prior to commencing treatment with GILENYA, if not contraindicated (see ADVERSE DRUG REACTIONS). For patients requiring vaccination, initiation of treatment with GILENYA should be delayed for 1 month after the patient has been vaccinated, to allow the full effect of the vaccination to occur (see WARNINGS AND PRECAUTIONS, Varicella Zoster Vaccination; WARNINGS AND PRECAUTIONS, Vaccination).

In the 24-month placebo controlled multiple sclerosis clinical trial in adults, the overall rate of infections (72%) and serious infections (2%) with GILENYA 0.5 mg was similar to that of placebo. However, bronchitis and pneumonia were more common in GILENYA-treated patients (see ADVERSE REACTIONS).

Physicians should advise patients about the potential for increased risk of infections and necessary vigilance during treatment and after discontinuation of treatment with GILENYA (see WARNINGS AND PRECAUTIONS, Immune System Effects Following Discontinuation of Treatment). For patients who develop serious infections, suspending treatment with GILENYA should be considered, and the benefits and risks of treatment should be re-assessed prior to re-initiation of treatment.

Herpetic infections

Two adult patients died of herpetic infections during controlled trials. One death was due to a disseminated primary varicella zoster infection and the other to herpes simplex encephalitis. In both cases, the patients were taking a 1.25 mg dose of fingolimod (higher than the recommended 0.5 mg dose) and had received prolonged (more than 5 days) concomitant corticosteroid therapy to treat suspected MS relapses.

Serious, life-threatening events of disseminated varicella zoster and herpes simplex infections, including cases of encephalitis and multiorgan failure, have occurred with GILENYA 0.5 mg in the post-marketing setting. One of these events, disseminated reactivation of varicella zoster virus in a patient that received prolonged concomitant corticosteroid therapy, was fatal.

Physicians should be vigilant for clinical symptoms that may be suggestive of serious herpetic infections. Disseminated herpetic infections should be included in the differential diagnosis when patients who are receiving GILENYA present with an atypical MS relapse or multiorgan failure. For cases of disseminated herpetic infections, antiviral therapy and discontinuation of GILENYA treatment is recommended. Treatment of zoster should follow current relevant guidelines.

Progressive Multifocal Leukoencephalopathy (PML)

Cases of progressive multifocal leukoencephalopathy (PML), some of which have been fatal, have been reported in the post-marketing setting (see ADVERSE REACTIONS). PML is an opportunistic infection caused by JC virus (JCV) that typically only occurs in patients who are immunocompromised, which may be fatal or result in severe disability. In some of the reported cases, PML has occurred in patients who were not previously treated with natalizumab, which has a known association with PML, and in patients who had not previously taken or were not

concomitantly taking any immunosuppressive or immunomodulatory medications. Other ongoing systemic medical conditions resulting in compromised immune system function were not reported in most of these cases. These cases of PML have occurred after approximately 2-3 years of treatment. The relationship between the risk of PML and duration of treatment is not known. The incidence rate for PML appears to be higher for patients in Japan; the reasons are currently unknown.

Physicians should be vigilant for clinical symptoms or MRI findings that may be suggestive of PML. If PML is suspected, GILENYA treatment should be suspended until PML has been excluded. Typical symptoms associated with PML are diverse, progress over days to weeks, and include progressive weakness on one side of the body or clumsiness of limbs, disturbance of vision, and changes in thinking, memory, and orientation leading to confusion and personality changes.

MRI findings suggestive of PML may be apparent before clinical signs or symptoms. Cases of PML, diagnosed based on MRI findings and the detection of JCV DNA in the cerebrospinal fluid in the absence of clinical signs or symptoms specific to PML, have been reported in patients treated with MS medications associated with PML, including GILENYA. Many of these patients subsequently became symptomatic with PML. Therefore, monitoring with MRI for signs that may be consistent with PML may be useful, and any suspicious findings should lead to further investigation to allow for an early diagnosis of PML, if present. Before initiating treatment with GILENYA, a recent MRI should be available. During routine MRI (in accordance with national and local recommendations), physicians should pay attention to PML suggestive lesions. Lower PML-related mortality and morbidity have been reported following discontinuation of another MS medication associated with PML in patients with PML who were initially asymptomatic compared to patients with PML who had characteristic clinical signs and symptoms at diagnosis. It is not known whether these differences are due to early detection and discontinuation of MS treatment or due to differences in disease in these patients.

Cryptococcal Meningitis

Cases of cryptococcal meningitis have been reported in the post-marketing setting, generally after approximately 2-3 years of treatment, but may occur earlier. The relationship between the risk of cryptococcal infection and the duration of treatment is not known (see ADVERSE REACTIONS). Some cases of cryptococcal meningitis have been fatal. Patients with symptoms and signs consistent with cryptococcal meningitis should undergo prompt diagnostic evaluation and appropriate treatment should be initiated if cryptococcal meningitis is diagnosed.

Human papilloma virus

Human papilloma virus (HPV) infection, including papilloma, dysplasia, warts and HPV-related cancer, has been reported under treatment with GILENYA in the post-marketing setting (see ADVERSE REACTIONS). Due to the immunosuppressive properties of fingolimod, vaccination against HPV should be considered prior to treatment initiation with GILENYA taking into account vaccination recommendations. Cancer screening, including Pap test, is recommended as per standard of care.

Vaccination

- The use of live attenuated vaccines during GILENYA treatment and for two months after discontinuing treatment is not recommended due to the risk of infection from the vaccine (see WARNINGS AND PRECAUTIONS, Infections).
- Vaccination may be less effective during and for up to two months after discontinuing treatment with GILENYA (see WARNINGS AND PRECAUTIONS, Immune System Effects Following Discontinuation of Treatment; ACTION AND CLINICAL PHARMACOLOGY, Pharmacodynamics-Immune system).
- For patients with negative IgG antibody test results for VZV due to no previous exposure or vaccination and who do not have contraindications for the vaccine, a full course of vaccination with varicella vaccine is recommended prior to commencing treatment with GILENYA. Initiation of GILENYA therapy should be postponed for one month after vaccination to allow the full effect of vaccination to occur (see WARNINGS AND PRECAUTIONS, Varicella Zoster Vaccination).
- The immunization recommendations for adults (routine and specific risk groups) from the National Advisory Committee on Immunization (NACI) (<http://www.phac-aspc.gc.ca/im/is-cv/index-eng.php>) and local infectious disease experts should be considered when evaluating the need for other vaccinations, before commencing and during treatment with GILENYA.

For pediatric patients, see WARNINGS AND PRECAUTIONS, Special Populations, Pediatric patients (10 years to < 18 years of age).

Immune System Effects Following Discontinuation of Treatment

If a decision is made to stop treatment with GILENYA, the physician and patient need to be aware that fingolimod remains in the blood and has pharmacodynamic effects, such as decreased lymphocyte counts for up to two months, following the last dose. Lymphocyte counts typically return to the normal range within 2 months of stopping therapy (see ACTION AND CLINICAL PHARMACOLOGY, Pharmacodynamics-Immune system). Physicians should advise patients about the potential for increased risk of infections and necessary vigilance for up to two months after discontinuation of treatment with GILENYA.

Because of the continuing pharmacodynamic effects of fingolimod, starting other therapies during the 2 months following stopping GILENYA warrants the same precautions as concomitant treatment with GILENYA. Use of immunosuppressants soon after the discontinuation of GILENYA may lead to an additive effect on the immune system and, therefore, caution should be applied (see DRUG INTERACTIONS and WARNINGS AND PRECAUTIONS, Return of disease activity (rebound) and severe increase in disability after GILENYA discontinuation)

Prior and Concomitant Treatment with Antineoplastic, Immunosuppressive or Immune-modulating Therapies

Co-administration of anti-neoplastic, immunosuppressive or immune-modulating therapies is not recommended due to the risk of additive immune system effects (see DRUG INTERACTIONS). For the same reason, corticosteroids should be co-administered with caution and specific decisions as to the dosage and duration of concomitant treatment should be based on clinical judgment. Co-administration of a short course of corticosteroids (up to 5 days as per study protocols) did not increase the overall rate of infection in patients treated with fingolimod in the Phase III clinical trials, compared to placebo.

When switching to or from another disease modifying therapy with immunosuppressive or immune modulating effects, the half-life and mode of action of GILENYA and the other therapy must be considered in order to avoid an additive immune effect whilst at the same time minimizing risk of disease reactivation. Prior to initiating the new treatment, a recent CBC should be available to ensure any immune effects (e.g. cytopenia) of the discontinued therapy have resolved.

Beta interferon, glatiramer acetate or dimethyl fumarate

GILENYA can generally be started immediately after discontinuation of beta interferon, glatiramer acetate or dimethyl fumarate provided that immune effects (e.g. cytopenia) from these therapies have resolved.

Natalizumab or teriflunomide

Elimination of natalizumab usually takes up to 2-3 months following discontinuation. Without an accelerated elimination procedure, clearance of teriflunomide from plasma can take several months (average: 8 months) and up to 2 years. Due to the long half-life of natalizumab or teriflunomide, caution regarding potential additive immune effects is required when switching patients from these therapies to GILENYA. A careful case-by-case assessment regarding the timing of the initiation of GILENYA treatment is recommended.

Alemtuzumab

Due to the characteristics and duration of alemtuzumab immune suppressive effects described in its Product Monograph, initiating treatment with GILENYA after alemtuzumab is not recommended unless the benefits of GILENYA treatment clearly outweigh the risks for the individual patient.

Hepatic/Biliary/Pancreatic

Liver function

Increased hepatic enzymes, mostly alanine aminotransaminase (ALT) elevation, have been reported in multiple sclerosis patients treated with GILENYA. In clinical trials, a 3-fold the upper limit of normal (ULN) or greater elevation in ALT occurred in 8% of adult patients treated with GILENYA 0.5 mg, as compared to 2% of patients on placebo. Elevations 5-fold the ULN occurred

in 2% of patients on GILENYA 0.5 mg and 1% of patients on placebo. In clinical trials, GILENYA was discontinued if the elevation exceeded 5 times the ULN. Recurrence of ALT elevations occurred with re-challenge in some patients, supporting a relationship to fingolimod. The majority of elevations occurred within 6-9 months of initiating treatment and serum transaminase levels returned to normal within approximately 2 months after discontinuation of GILENYA (see ADVERSE REACTIONS, Abnormal Hematologic and Clinical Chemistry Findings-Liver function).

For all patients, recent (i.e. within last 6 months) transaminase and bilirubin levels should be available before initiation of treatment with GILENYA. During treatment, liver enzymes should be evaluated every 3 months for the first year and periodically thereafter. If liver transaminases rise above 5 times the ULN, more frequent monitoring should be instituted, including serum bilirubin and alkaline phosphatase (ALP) measurement. With repeated confirmation of liver transaminases above 5 times the ULN, treatment with GILENYA should be interrupted and only re-commenced once liver transaminase values have normalized. The benefits and risks of treatment should be re-assessed prior to re-initiation of treatment.

Patients who develop symptoms suggestive of hepatic dysfunction, such as unexplained vomiting, abdominal pain, fatigue, anorexia, or jaundice and/or dark urine during treatment, should have liver enzymes checked and GILENYA should be discontinued if significant liver injury is confirmed (see ADVERSE REACTIONS, Abnormal Hematologic and Clinical Chemistry Findings, Liver function).

Patients with pre-existing liver disease may be at an increased risk of developing elevated liver enzymes during GILENYA treatment (see WARNINGS AND PRECAUTIONS, Special Populations; ACTION AND CLINICAL PHARMACOLOGY, Pharmacokinetics-Special Populations and Conditions).

Neoplasm

For patients treated with immunosuppressive or immune modulating drugs there is potential for an increased risk of lymphomas and other malignancies, particularly of the skin.

Lymphoma

Cases of lymphoma, mainly Non-Hodgkin's Lymphoma, including both T-cell and B-cell types and CNS lymphoma, have been reported in clinical trials and in the post-marketing setting with GILENYA (see ADVERSE REACTIONS). The cases reported were heterogeneous in nature. The incidence of lymphoma (B-cell and T-cell) cases was higher in clinical trials than expected in the general population. Cutaneous T-cell lymphoma (including mycosis fungoides) has been reported with GILENYA in the post-market setting (see ADVERSE REACTIONS).

Basal cell carcinoma and other cutaneous neoplasms

Basal cell carcinoma (BCC) and other cutaneous neoplasms, including malignant melanoma, squamous cell carcinoma, Merkel cell carcinoma and Kaposi's sarcoma have been reported in patients receiving GILENYA (see ADVERSE REACTIONS). Vigilance for cutaneous neoplasms is recommended in patients receiving GILENYA. Health care professionals and patients are

advised to monitor for suspicious skin lesions before initiating treatment and regularly during treatment with GILENYA, particularly for patients with risk factors for skin cancer. If a suspicious skin lesion is observed, it should be promptly evaluated.

Since there is a potential risk of malignant skin growths, patients treated with GILENYA should be cautioned against exposure to sunlight and ultraviolet light by wearing protective clothing and using a sunscreen with a high protection factor. These patients should not receive concomitant phototherapy with UV-B-radiation or PUVA-photochemotherapy.

Neurologic

Posterior reversible encephalopathy syndrome

Rare cases of posterior reversible encephalopathy syndrome (PRES) have been reported in adults at 0.5 mg dose in clinical trials and in the post-marketing setting. Symptoms reported included sudden onset of severe headache, nausea, vomiting, altered mental status, visual disturbances and seizure; status epilepticus has been reported in association with PRES. Symptoms of PRES are usually reversible but may evolve into ischemic stroke or cerebral hemorrhage. Delay in diagnosis and treatment may lead to permanent neurological sequelae. If PRES is suspected, GILENYA should be discontinued.

Tumefactive lesions

Cases of tumefactive lesions associated with MS relapse have been reported in the post-marketing setting. In case of severe relapses, MRI should be performed to exclude tumefactive lesions. Discontinuation of GILENYA should be considered by the physician on a case-by-case basis taking into account individual benefits and risks.

Return of disease activity (rebound) and severe increase in disability after GILENYA discontinuation

Severe increase in disability accompanied by multiple new lesions on MRI has been reported after discontinuation of GILENYA in the postmarketing setting. Patients in most of these reported cases did not return to the functional status they had before stopping GILENYA. The increase in disability generally occurred within 12 weeks after stopping GILENYA, but was reported up to and beyond 24 weeks after GILENYA discontinuation. Therefore, caution is indicated when stopping GILENYA therapy. Monitor patients for development of high disease activity and severe increase in disability following discontinuation of GILENYA and begin appropriate treatment as needed.

Seizures

Caution should be exercised when administering GILENYA to patients with pre-existing seizure disorder. In the pivotal adult and pediatric studies, cases of seizures were reported at a greater incidence for fingolimod-treated patients compared to their respective control arms (see

ADVERSE REACTIONS, Clinical Trials Adverse Reactions; ADVERSE REACTIONS, Clinical Trials Adverse Reactions (Pediatrics)). It is not known whether these events were related to the effects of MS alone, to GILENYA, or to a combination of both.

Ophthalmologic

Macular Edema

Macular edema (see ADVERSE REACTIONS, Macular edema) with or without visual symptoms has been reported in 0.4% of adult patients treated with GILENYA 0.5 mg compared to 0.1% of patients receiving placebo. Macular edema was diagnosed predominantly in the first 3-4 months of therapy. Some patients presented with blurred vision or decreased visual acuity, but others were asymptomatic and diagnosed on routine ophthalmic examination. Macular edema generally improved or resolved with or without treatment after drug discontinuation, but some patients had residual visual acuity loss even after resolution of macular edema. In clinical trials, treatment with GILENYA was discontinued when patients developed macular edema and was not re-initiated when the adverse event resolved.

An ophthalmic evaluation is recommended 3-4 months after treatment initiation. If patients report visual disturbances at any time while on GILENYA therapy, an evaluation of the fundus, including the macula, should be carried out (see WARNINGS AND PRECAUTIONS, Patient Counseling Information).

It is recommended that GILENYA be discontinued if a patient develops macular edema. Continuation of treatment in patients with macular edema has not been evaluated. A decision on whether or not GILENYA therapy should be re-initiated after resolution of macular edema needs to take into account the potential benefits and risks for the individual patient.

Macular edema in patients with history of uveitis or diabetes mellitus

Patients with a history of uveitis and patients with diabetes mellitus are at increased risk of macular edema (see ADVERSE REACTIONS, Macular edema). Multiple sclerosis patients with concomitant diabetes mellitus were excluded from the clinical trials with GILENYA. In other clinical trials with GILENYA that included diabetic patients, the rate of macular edema was several-fold greater in diabetic patients compared to non-diabetic patients, and macular edema was twice as frequent in patients treated with GILENYA (diabetic and non-diabetic) compared to patients receiving control treatment.

In addition to an ophthalmic evaluation prior to initiating GILENYA therapy and at 3-4 months after initiating treatment, regular follow-up evaluations are recommended for multiple sclerosis patients with diabetes mellitus or a history of uveitis while receiving GILENYA therapy.

Respiratory

Dose-dependent reductions in forced expiratory volume over 1 second (FEV1) and diffusion lung capacity for carbon monoxide (DLCO) were observed in patients treated with GILENYA as early as 1 month after treatment initiation (see ADVERSE REACTIONS, Respiratory). The changes in FEV1 appear to be reversible after treatment discontinuation, but there is insufficient information to determine the reversibility of the decrease of DLCO after drug discontinuation.

Spirometric evaluation of respiratory function and evaluation of DLCO should be performed during therapy with GILENYA if clinically indicated.

Multiple sclerosis patients with compromised respiratory function (e.g., pulmonary fibrosis, diagnosis of active pulmonary disease, abnormal pulmonary function tests) were excluded from GILENYA clinical trials.

GILENYA should be used with caution in patients with severe respiratory disease, pulmonary fibrosis, moderate and severe asthma or chronic obstructive pulmonary disease (see ACTION AND CLINICAL PHARMACOLOGY, Pharmacodynamics-Pulmonary Function).

Metabolic

Total Cholesterol, LDL Cholesterol, and Triglycerides

GILENYA treatment results in increased levels of total cholesterol, LDL cholesterol, and triglycerides (see ADVERSE REACTIONS, Cholesterol and Triglycerides). These observations should be taken into consideration when treating patients with pre-existing hyperlipidemia, atherosclerosis, or ischemic heart disease.

Psychiatric

Depression and Suicidal Ideation:

In the controlled pediatric trial, cases of depressed mood and depression have been reported with higher incidence in patients treated with fingolimod compared to patients treated with interferon beta-1a. Depression and suicidal ideation are known to occur at an increased frequency in the MS population. A relationship between the occurrence of depression and/or suicidal ideation and the use of GILENYA in the MS population has not been established. Patients, families and caregivers of patients being treated with GILENYA should be advised to monitor for the emergence of any symptoms of depression and/or suicidal ideation and report such symptoms immediately to healthcare providers, for prompt evaluation.

Sexual Function/Reproduction

Labor and delivery

There are no data on the effects of fingolimod on labor and delivery.

Infertility

Data from preclinical studies does not suggest that fingolimod would be associated with an increased risk of reduced fertility.

Female reproductive toxicity

Based on animal data, GILENYA is potentially teratogenic (see CONTRAINDICATIONS, WARNINGS AND PRECAUTIONS, Special Populations-Pregnant women).

Male reproductive toxicity

Available data do not suggest that GILENYA would be associated with an increased risk of male-mediated fetal toxicity.

Special Populations

Women of childbearing potential / Contraception: GILENYA is contraindicated in women (including female adolescents) who are pregnant or of child bearing potential not using effective contraception (see CONTRAINDICATIONS). Therefore, before initiation of treatment in women of childbearing potential, a negative pregnancy test result must be available and counselling should be provided regarding the serious risk to the fetus. Women of childbearing potential must use effective contraception during treatment and for 2 months after discontinuation of GILENYA, since fingolimod takes approximately 2 months to eliminate from the body after treatment discontinuation (see ACTION AND CLINICAL PHARMACOLOGY, Pharmacodynamics-Immune system). If the woman becomes pregnant while taking this drug, the patient must be apprised of the risk to the fetus.

Pregnant Women: GILENYA is contraindicated in women (including female adolescents) who are pregnant or of child bearing potential not using effective contraception (see CONTRAINDICATIONS). There are no adequate and well-controlled studies in pregnant women.

Available human data (post-marketing data and pregnancy registry information) suggest that use of GILENYA is associated with an increased risk of overall major congenital malformation (approximately 5%) when administered during pregnancy in comparison with the prevalence observed in the general population (2-4%).

The pattern of malformation reported for GILENYA is similar to that observed in the general population, however, increased prevalence of the following specific major malformations were noted:

- Congenital heart disease such as atrial septal defects
- Renal abnormalities
- Musculoskeletal abnormalities

If a female becomes pregnant while taking GILENYA, treatment must be discontinued.

GILENYA must be discontinued 2 months before planning a pregnancy. Medical advice should be given regarding the risk of harmful effects on the fetus associated with treatment and medical follow-up examination should be performed (e.g. ultrasonography examination). Also, the possibility of severe exacerbation of disease should be considered in females discontinuing GILENYA because of pregnancy or planned pregnancy, and patients should consult their physicians on potential alternatives (see WARNINGS AND PRECAUTIONS, Return of disease activity (rebound) and severe increase in disability after GILENYA discontinuation and Immune System Effects Following Discontinuation of Treatment).

Animal studies have shown that fingolimod induced reproductive toxicity including fetal loss and teratogenicity when given to pregnant animals. When fingolimod was administered orally to pregnant rats during the period of organogenesis, increased incidences of fetal malformations and embryo-fetal lethality were observed starting at doses corresponding to 2 times the exposure in humans at the recommended dose of 0.5 mg. The most common fetal visceral malformations in rats included persistent truncus arteriosus and ventricular septal defect. Oral administration of fingolimod to pregnant rabbits during organogenesis resulted in increased incidences of embryo-fetal lethality and fetal growth retardation starting at doses similar to the exposure in humans at the recommended dose of 0.5 mg (see TOXICOLOGY).

Pregnancy exposure registry: There is a registry that monitors pregnancy outcomes in women exposed to GILENYA during pregnancy. If a patient becomes pregnant while taking GILENYA, physicians are encouraged to report this event by calling the GILENYA Pregnancy Registry at 1-855-788-5333 or visiting www.gilenyapregnancyregistry.com.

Nursing Women: Fingolimod is excreted in the milk of animals treated during lactation. There are no data on the effects of GILENYA on the breastfed child or the effects of GILENYA on milk production. Since many drugs are excreted in human milk and because of the potential for serious adverse drug reactions to fingolimod in nursing infants, women receiving GILENYA should not breast feed.

Hepatic Impairment: GILENYA is contraindicated in patients with severe hepatic impairment (Child-Pugh Class C) (see CONTRAINDICATIONS). Although no dose adjustments are needed in patients with mild or moderate hepatic impairment, caution should be exercised when initiating treatment with GILENYA in these patients (see ACTION AND CLINICAL PHARMACOLOGY, Pharmacokinetics - Special Populations and Conditions).

Patients with pre-existing liver disease were excluded from MS clinical trials and it is not known if these patients are at an increased risk of developing elevated liver function tests, more severe liver injury, or other adverse events during treatment with GILENYA (see WARNINGS AND PRECAUTIONS, Hepatic/Biliary/Pancreatic).

Renal Impairment: Caution is recommended when using GILENYA in patients with severe renal impairment (see ACTION AND CLINICAL PHARMACOLOGY, Pharmacokinetics - Special Populations and Conditions).

Pediatric patients (10 to < 18 years of age): It is recommended that pediatric patients complete all immunizations in accordance with current immunization guidelines prior to initiating GILENYA therapy.

Pediatrics (< 10 years of age): The safety and efficacy of GILENYA in pediatric patients below 10 years of age have not been studied.

Geriatrics (> 65 years of age): Clinical studies of GILENYA did not include sufficient numbers of patients aged 65 years and over to assess efficacy and safety in this age group. Due to the greater frequency of reduced hepatic, renal, immune, pulmonary and cardiovascular function, other concomitant diseases and concomitant drug therapy, treatment with GILENYA merits caution and may necessitate additional or more frequent monitoring in geriatric patients (see CONTRAINDICATIONS and WARNINGS AND PRECAUTIONS).

Patient Counseling Information

Consumer Information is included in the package of GILENYA dispensed to the patient. Patients receiving GILENYA should also be given the following information by the physician and /or pharmacist:

1. *General*

Summarize for patients the benefits and potential risks of treatment with GILENYA.

Tell patients to take GILENYA once daily as prescribed. Tell patients not to discontinue GILENYA without first discussing this with the prescribing physician.

2. *First-dose cardiovascular effects and monitoring*

Advise patients that initiation of fingolimod treatment results in a decrease in heart rate. Inform patients that they will need to have their heart rate and blood pressure monitored in the doctor's office or other medical facility for at least 6 hours after the first dose, and that they will be required to have an ECG performed prior to dosing and at the end of the 6-hour monitoring period. Also inform patients that in case of abnormal ECG recording, very slow heart rate at the end of the 6-hour observation period, or symptoms of bradyarrhythmia they will need to be monitored longer, possibly overnight, until findings have resolved. Symptoms of bradyarrhythmia may include dizziness or palpitations. Advise patients that if fingolimod is discontinued for more than two weeks, effects similar to those observed on treatment initiation may be seen and observation for at least 6 hours, including periodic assessment of heart rate, will be needed on treatment re-initiation.

3. *Risk of Infections*

Inform patients that they may be more likely to get infections when taking GILENYA, and that they should contact their physician if they develop symptoms of infection. Advise patients that there is the potential for additive immune system effects if corticosteroid therapy is required. Advise patients that the use of some vaccines should be avoided during treatment with GILENYA and for 2 months after discontinuation. Advise patients who have not had

chickenpox or vaccination with varicella vaccine that the vaccination is recommended prior to commencing treatment with GILENYA.

4. *Blood pressure increase*

Advise patients that an increase in blood pressure could occur during chronic treatment with GILENYA and that regular monitoring of blood pressure should be undertaken.

5. *Liver enzyme increases*

Inform patients that GILENYA may increase liver enzymes. Advise patients that regular blood testing will be performed and that they should contact their physician if they have any unexplained nausea, vomiting, abdominal pain, fatigue, anorexia, or jaundice and/or dark urine during treatment.

6. *Macular edema*

Advise patients that GILENYA may cause macular edema, and that they should contact their physician if they experience any changes in their vision. Inform patients with diabetes mellitus or a history of uveitis that their risk of macular edema is increased.

7. *Respiratory effects*

Advise patients that they should contact their physician if they experience new onset or worsening dyspnea.

8. *Fetal risk*

GILENYA has been shown to be potentially teratogenic in animal studies. It is contraindicated in women of childbearing potential (including female adolescents) not using effective contraception and in pregnant women.

- A negative pregnancy test must be confirmed prior to starting treatment, and it must be repeated at suitable intervals.
- Women of childbearing potential, including adolescent females, their parents (or legal representatives), and caregivers must be counselled before treatment initiation and regularly thereafter about the serious risks of GILENYA to the fetus.
- Women of childbearing potential must use effective contraception during treatment and for two months following treatment discontinuation.
- While on treatment, females must not become pregnant. If a patient becomes pregnant while on treatment, GILENYA must be discontinued. When stopping GILENYA treatment due to pregnancy or for planning a pregnancy, the possible return of disease activity should be considered. Medical advice must be given regarding the risk of harmful effects to the fetus associated with GILENYA treatment and ultrasonography examinations should be performed.
- GILENYA must be stopped 2 months before planning a pregnancy.

9. Drug interactions

Advise patients that concomitant use of certain cardiac medications may increase the risk of bradyarrhythmia with first-dose administration of GILENYA and ask them to provide information on all medications currently being taken.

Advise patients that co-administration of anti-neoplastic, immunosuppressive or immune-modulating therapies is not recommended due to the risk of additive immune system effects.

10. Persistence of GILENYA effects after drug discontinuation

Advise patients that GILENYA remains in the blood and continues to have effects, including decreased blood lymphocyte counts, for up to 2 months following the last dose.

11. Risk of skin cancer

Inform patients that cases of skin cancers have been reported in MS patients treated with GILENYA therefore, patients should monitor and report any suspicious lesion before treatment initiation and during GILENYA treatment. Advise patients to limit their exposure to sunlight and UV rays through appropriate protective clothing and application of sunscreen with a high degree of UV protection.

12. Cases of PML

Inform patients that cases of progressive multifocal leukoencephalopathy (PML) have occurred after approximately 2-3 years of monotherapy treatment although an exact relationship with the duration of treatment is unknown.

13. Risk of return of disease activity and severe increase in disability

Inform patients that after GILENYA treatment is stopped, symptoms of MS can return and may become worse compared to before or during treatment. Advise patients that they should contact their physician if their MS symptoms get worse after stopping GILENYA.

14. Symptoms of PRES

Inform patients that the symptoms of posterior reversible encephalopathy syndrome (PRES) may include sudden onset of severe headache, confusion, seizures and vision changes.

15. Risk of tumefactive lesions

Inform patients that a condition with unusually large brain lesions associated with MS relapse have been rarely reported in patients treated with GILENYA (a condition called tumefactive lesions). Advise patients that in case of severe relapse, a MRI scan may be performed to evaluate this condition and a decision to stop treatment can be made on a case by case basis.

ADVERSE REACTIONS

Adverse Drug Reaction Overview

A total of 1703 adult patients on GILENYA (fingolimod) (0.5 or 1.25 mg dose) constituted the safety population in the two Phase III studies (D2301 and D2302) for approval in patients with relapsing-remitting multiple sclerosis (see CLINICAL TRIALS). Study D2301 (FREEDOMS) was a 2-year placebo-controlled clinical study involving 1272 multiple sclerosis adult patients treated with fingolimod (854: 425 on fingolimod 0.5 mg, 429 on fingolimod 1.25 mg) or placebo (418).

In this study, the most serious adverse events (AEs) for the 0.5 mg recommended therapeutic dose were infections, macular edema, and bradycardia or atrioventricular blocks on treatment initiation (see WARNINGS AND PRECAUTIONS). The most frequent AEs (incidence $\geq 10\%$ and more frequent than with placebo) reported with the 0.5 mg dose were headache, influenza, diarrhea, back pain, liver enzyme elevations and cough. The only adverse event that led to more than 1% of patients receiving GILENYA 0.5 mg to stop therapy was serum transaminase elevations, leading to drug discontinuation in 3.8% of patients.

Study D2302 (TRANSFORMS) was a 1-year controlled study using interferon beta-1a as comparator involving 1280 adult patients with multiple sclerosis treated with fingolimod (849: 429 on fingolimod 0.5 mg, 420 on fingolimod 1.25 mg) or interferon beta-1a (431). In Study D2302, the most frequently reported AEs ($\geq 10\%$), serious AEs and AEs leading to discontinuation were generally similar to those reported in placebo-controlled studies, taking into account the differences in study duration.

Clinical Trial Adverse Drug Reactions

Because clinical trials are conducted under very specific conditions the adverse reaction rates observed in the clinical trials may not reflect the rates observed in practice and should not be compared to the rates in the clinical trials of another drug. Adverse drug reaction information from clinical trials is useful for identifying drug-related adverse events and for approximating rates.

Treatment emergent adverse events (AEs) are listed according to MedDRA system organ class.

Table 1 - Treatment emergent AEs occurring in $\geq 1\%$ of patients in Study D2301, and reported for GILENYA 0.5 mg at $\geq 1\%$ higher rate than for placebo.

Primary system organ class Preferred Term	Placebo N=418 (%)	Fingolimod 0.5mg N=425 (%)
Infections		
Influenza viral infections	41 (9.8)	55 (12.9)
Bronchitis	15 (3.6)	34 (8.0)

Table 1 - Treatment emergent AEs occurring in $\geq 1\%$ of patients in Study D2301, and reported for GILENYA 0.5 mg at $\geq 1\%$ higher rate than for placebo.

Primary system organ class Preferred Term	Placebo N=418 (%)	Fingolimod 0.5mg N=425 (%)
Sinusitis	19 (4.5)	28 (6.6)
Gastroenteritis	13 (3.1)	19 (4.5)
Pneumonia*	1 (0.2)	2 (0.5)
Herpes viral infections*	33 (7.9)	37 (8.7)
Tinea infections	6 (1.4)	16 (3.8)
Cardiac Disorders		
Bradycardia	4 (1.0)	15 (3.5)
Nervous system disorders		
Headache	96 (23.0)	107 (25.2)
Dizziness	23 (5.5)	31 (7.3)
Paresthesia	18 (4.3)	23 (5.4)
Migraine	6 (1.4)	20 (4.7)
Gastrointestinal disorders		
Diarrhea	31 (7.4)	50 (11.8)
General disorders and administration site conditions		
Asthenia	5 (1.2)	11 (2.6)
Musculoskeletal and connective tissue disorders		
Back pain	29 (6.9)	50 (11.8)
Skin and subcutaneous tissue disorders		
Eczema	8 (1.9)	14 (3.3)
Alopecia	10 (2.4)	15 (3.5)
Pruritus	5 (1.2)	11 (2.6)
Investigations		
Alanine transaminase (ALT) increased	16 (3.8)	43 (10.1)
Gamma-glutamyl transferase (GGT) increased	4 (1.0)	22 (5.2)
Hepatic enzyme increased	1 (0.2)	14 (3.3)
Weight decreased	14 (3.3)	20 (4.7)
Blood triglycerides increased	5 (1.2)	11 (2.6)
Liver function test abnormal	1 (0.2)	6 (1.4)

Table 1 - Treatment emergent AEs occurring in $\geq 1\%$ of patients in Study D2301, and reported for GILENYA 0.5 mg at $\geq 1\%$ higher rate than for placebo.

Primary system organ class Preferred Term	Placebo N=418 (%)	Fingolimod 0.5mg N=425 (%)
Respiratory, thoracic and mediastinal disorders		
Cough	34 (8.1)	43 (10.1)
Dyspnea	19 (4.5)	34 (8.0)
Psychiatric disorders		
Depression	28 (6.7)	33 (7.8)
Eye disorders		
Eye pain	6 (1.4)	11 (2.6)
Vision blurred	6 (1.4)	15 (3.5)
Vascular disorders		
Hypertension	16 (3.8)	27 (6.4)
Blood and lymphatic system disorders		
Leucopenia	1 (0.2)	12 (2.8)
Lymphopenia	2 (0.5)	15 (3.5)

* Plausible relationship to study drug

Infections

In the two-year multiple sclerosis clinical trial, the overall rate of infections (72%) and serious infections (2%) at the 0.5 mg dose was similar to placebo. However, bronchitis and pneumonia were more common in GILENYA-treated patients (Table 1).

There have been very rare fatal cases of VZV infections in patients taking GILENYA (at the recommended dose or higher doses used in clinical trials). These patients received prolonged concomitant corticosteroid use (more than 5 days) for treatment of multiple sclerosis relapses.

There have been very rare cases of other herpes viral infections with fatal outcome. Some cases of disseminated herpes infections have been reported, including fatal cases, with one case at the 0.5 mg dose (see WARNINGS AND PRECAUTIONS, Herpetic Infections).

Human papilloma virus (HPV) infection, including papilloma, dysplasia, warts and HPV-related cancer, has been reported under treatment with GILENYA in the post-marketing setting (see WARNINGS AND PRECAUTIONS, Human papilloma virus).

Macular Edema

In clinical trials, macular edema occurred in 0.4% of patients treated with the recommended GILENYA dose of 0.5 mg, 1.1% of patients treated with the higher 1.25 mg dose, and in 0.1% of patients that received placebo.

The majority of cases in multiple sclerosis clinical trials occurred within the first 3-4 months of therapy. Some patients presented with blurred vision or decreased visual acuity, but others were asymptomatic and diagnosed on routine ophthalmic examination. Treatment with GILENYA was discontinued in all cases of macular edema. The macular edema generally improved or resolved spontaneously after drug discontinuation. The risk of recurrence after re-challenge has not been evaluated (see WARNINGS AND PRECAUTIONS, Ophthalmologic).

Macular edema incidence is increased in multiple sclerosis patients with a history of uveitis (approximately 20% in those with a history of uveitis vs. 0.6% without a history of uveitis).

Patients with diabetes mellitus were excluded from multiple sclerosis clinical trials. In renal transplant clinical studies where patients with diabetes mellitus were included, the incidence of macular edema was several-fold greater in patients with diabetes compared to non-diabetic patients. In addition, therapy with fingolimod 2.5 mg and 5 mg resulted in a 2-fold increase in the incidence of macular edema in those studies. Multiple sclerosis patients with diabetes mellitus are therefore expected to be at a higher risk for macular edema (see WARNINGS AND PRECAUTIONS, Ophthalmologic).

ECG Findings

GILENYA was associated with PR interval prolongation, QTc interval prolongation, and decreased heart rate (see WARNINGS AND PRECAUTIONS, Cardiovascular; DRUG INTERACTIONS, Pharmacodynamic Interactions; ACTION AND CLINICAL PHARMACOLOGY, Pharmacodynamics-Heart rate and rhythm, -Thorough QT Study).

Bradycardia

Initiation of GILENYA treatment results in a reversible decrease in heart rate that may also be associated with AV conduction delays (see WARNINGS AND PRECAUTIONS, Cardiovascular; DRUG INTERACTIONS, Pharmacodynamic Interactions; ACTION AND CLINICAL PHARMACOLOGY, Pharmacodynamics-Heart rate and rhythm).

In multiple sclerosis clinical trials the mean maximum decrease in heart rate after taking the first dose was seen within 6 hours post-dose, with a decline in the mean heart rate of 8 beats per minute for GILENYA 0.5 mg at 5 h post-dosing. The placebo-adjusted change in mean hourly heart rate at 6 h post-dosing was approximately 13 beats per minute according to 24 h Holter monitoring. The second dose may result in a slight further decrease. Patients who experienced bradycardia were generally asymptomatic but some patients experienced mild to moderate symptoms, including hypotension, dizziness, fatigue, palpitations, and/or chest pain or chest discomfort, which resolved

within the first 24 hours of treatment. Heart rate returned to baseline within 1 month of chronic dosing.

In the multiple sclerosis clinical trial program first-degree AV block (prolonged PR interval on ECG) was detected following drug initiation in 4.7% of patients-receiving GILENYA 0.5 mg, in 2.8% of patients receiving intramuscular interferon beta-1a and in 1.5% of patients receiving placebo. Second-degree AV block Mobitz type 1 (Wenckebach) was detected in 0.2% of adult patients on GILENYA 0.5 mg.

Isolated reports of complete AV block during the 6 hour observation period and delayed onset cardiac events, including transient asystole and unexplained death within 24 hours of the first dose, have been reported during post-marketing experience (see ADVERSE REACTIONS, Post-Market Adverse Events). These events were confounded by concomitant and/or pre-existing disease, and the relationship to GILENYA cannot be excluded.

The conduction abnormalities observed both in clinical trials and post-marketing were typically transient, asymptomatic and resolved within 24 hours. Although most patients in clinical trials did not require medical intervention, one patient on the 0.5 mg dose received isoprenaline (isoproterenol) for an asymptomatic 2nd-degree Mobitz I AV block.

Blood pressure

GILENYA is associated with a *decrease* of blood pressure after the first dose. Chronic treatment is associated with an *increase* in blood pressure.

On the first day of treatment in multiple sclerosis clinical trials, GILENYA was associated with a decrease in systolic, diastolic, and mean arterial BP, starting at 1 hour post-dose, reaching its maximal decrease after 4-5 hours. The maximal decrease from pre-dose values in mean arterial BP was 3.5 mmHg (5 hours post-dose) in the GILENYA 0.5 mg group compared to a maximal mean decrease of 1.8 mmHg (4 hours post-dose) in the placebo group (see WARNINGS AND PRECAUTIONS, Cardiovascular; ACTION AND CLINICAL PHARMACOLOGY, Pharmacodynamics-Blood Pressure). Cases of syncope were also reported after the first dose of GILENYA in the post-marketing setting.

In multiple sclerosis clinical trials GILENYA 0.5 mg was associated with increases of approximately 2 mmHg in systolic pressure, and 1 mmHg in diastolic pressure manifesting after approximately 1 month of treatment initiation. These increases persisted with continued treatment. In controlled studies involving 854 multiple sclerosis patients on GILENYA 0.5 mg and 511 multiple sclerosis patients on placebo, hypertension was reported as an adverse reaction in 5% of patients on GILENYA 0.5 mg and in 3% of patients on placebo.

Vascular events

Rare cases of ischemic stroke and hemorrhagic stroke have been reported in patients treated with GILENYA in clinical trials and in the post-marketing setting. The relationship to GILENYA

remains uncertain. In phase III clinical trials, rare cases of peripheral arterial occlusive disease occurred in patients receiving fingolimod at doses of 1.25 mg (2.5 times the recommended dose) and 5.0 mg (10 times the recommended dose).

Neoplasms

There have been cases of cutaneous neoplasms and lymphoma reported in clinical studies and the post-marketing setting (see WARNINGS AND PRECAUTIONS, Neoplasms).

Basal cell carcinoma and other cutaneous neoplasms

In pooled data from the two placebo-controlled Phase III clinical trials, D2301 (FREEDOMS) and D2309 (FREEDOMS II), basal cell carcinoma has been reported in 14/783 (1.8%) patients receiving fingolimod, and in 5/773 (0.6%) patients on placebo.

During Phase III placebo controlled clinical trials there was no difference in the frequency of melanoma in patients treated with fingolimod for up to 2 years, compared to patients receiving placebo. In open label clinical trials and in the post-marketing setting, melanoma has been reported in a small number of patients, who were treated with fingolimod, and who had no apparent risk factors, signs of melanoma at treatment initiation or concurrent medical conditions (see WARNINGS AND PRECAUTIONS, Neoplasm).

Kaposi's sarcoma has been reported in clinical trials and in the post-marketing setting in patients treated with fingolimod who did not have risk factors commonly associated with Kaposi's sarcoma.

Lymphoma

Cases of lymphoma have been reported in clinical studies and the post-marketing setting. The reported lymphoma cases were heterogeneous in nature, mainly Non-Hodgkin's Lymphoma, including B-cell and T-cell lymphomas. Cases of cutaneous T-cell lymphoma (including mycosis fungoides) have been observed in the post-marketing setting.

Respiratory system

Dose-dependent reductions in forced expiratory volume over 1 second (FEV1) and diffusion lung capacity for carbon monoxide (DLCO) were observed in patients treated with GILENYA as early as 1 month after treatment initiation (see WARNINGS AND PRECAUTIONS, Respiratory). At Month 24, the reduction from baseline in the percent of predicted values for FEV1 was 3.1% for GILENYA 0.5 mg and 2.0% for placebo, corresponding to a mean decrease of 150 mL/s and 120 mL/s, respectively. For DLCO, the reductions from baseline in percent of predicted values at Month 24 were 3.8% for GILENYA 0.5 mg and 2.7% for placebo. The changes in FEV1 appear to be reversible after treatment discontinuation, but there is insufficient information to determine the reversibility of the decrease of DLCO after drug discontinuation.

In the 24-month multiple sclerosis placebo-controlled trial, dyspnea was reported in 7.1% of patients receiving GILENYA 0.5 mg and 4.5% of patients receiving placebo. Several patients discontinued GILENYA because of unexplained dyspnea during the extension (uncontrolled) studies.

Seizures

Cases of seizures, including status epilepticus, have been reported with the use of GILENYA in clinical trials and in the post-marketing setting. In clinical trials, the rate of seizures was 0.9% in GILENYA treated patients and 0.3% in placebo treated patients. It is unknown whether these events were related to the effects of multiple sclerosis alone, to GILENYA, or to a combination of both.

Other Adverse Events Observed During Double blind Controlled Clinical Trials in MS

The D2309 study (FREEDOMS II) was a 2-year prospective, double blind study designed to evaluate the efficacy, safety, and tolerability of two doses of fingolimod (1.25 mg and 0.5 mg) compared with placebo in patients with RRMS. This Phase III study was completed after the approval of the fingolimod. The three arms of the study were fingolimod 1.25 mg (n=370); fingolimod 0.5 mg (n=358) and placebo (n=355). The safety data from the study were very consistent with the D2301 study. In this study, the incidence of increased AST adverse events was higher for fingolimod (0.5 mg) than placebo (3.1% vs 1.4%).

Clinical Trial Adverse Reactions (Pediatrics)

The safety assessment for pediatric multiple sclerosis patients is based on safety data from patients in Study D2311, an active-controlled study with flexible duration up to 24 months (Core Phase) involving 215 pediatric patients (10 to below 18 years of age) treated with fingolimod (107) or interferon beta-1a (108) (see CLINICAL TRIALS). In this study, the safety profile in pediatric patients receiving fingolimod 0.25 mg or 0.5 mg daily (dose regimen based on body weight) was similar to that seen in adult patients, with respect to the types of AEs reported. The overall incidence of AEs in the fingolimod and interferon beta-1a groups was 88.8% vs. 95.3%, respectively. The most frequently reported AEs were headache and viral upper respiratory tract infections; reported at a comparable frequency in both the treatment groups. The most common adverse events occurring at $\geq 10\%$ in the pediatric patients receiving fingolimod and reported at a $\geq 2\%$ higher rate than in patients treated with interferon beta-1a were viral upper respiratory tract infection (21.5% vs. 24.3%), upper respiratory tract infection (15.9% vs. 4.7%), leucopenia (14.0% vs. 2.8%) and influenza (11.2% vs. 3.7%). In the pediatric study, cases of seizures were reported in 5.6% of fingolimod-treated patients and 0.9% of interferon beta-1a treated patients (see WARNINGS AND PRECAUTIONS, Neurologic, Seizures). Anxiety, depressed mood and depression showed a higher incidence in fingolimod-treated patients (6.5%, 4.7%, and 4.7%, respectively) compared to interferon beta-1a treated patients (1.9%, 0%, and 2.8%, respectively) (see WARNINGS AND PRECAUTIONS, Psychiatric, Depression and Suicidal Ideation).

Post-Market Adverse Reactions

The following adverse reactions have been reported during post-marketing experience:

Cardiac Disorders: Isolated reports of transient, spontaneously resolving complete AV block have

been observed during the six-hour observation period with GILENYA. Isolated delayed-onset events, including transient asystole and unexplained death, have occurred within 24 hours of the first dose of GILENYA. These cases have been confounded by concomitant medications and/or pre-existing disease, but the relationship to GILENYA cannot be excluded.

Infections and Infestations: Hemophagocytic syndrome with fatal outcome has been reported with fingolimod treatment in the context of infection. Hemophagocytic syndrome is a rare condition that has been described in association with infections and a variety of autoimmune disease and cases have been reported in patients with MS.

Cases of infections with opportunistic viral (e.g. VZV, JCV causing PML, HSV), fungal (e.g. cryptococci including cryptococcal meningitis), or bacterial (e.g. atypical mycobacterium) pathogens, have been reported, some of which have been fatal (see WARNINGS AND PRECAUTIONS, Immune).

Immune system disorders: Hypersensitivity reactions, including rash, urticaria and angioedema upon treatment initiation.

Gastrointestinal disorders: nausea

Hematologic: thrombocytopenia

Investigations: Weight decreased

Musculoskeletal and connective tissue disorders: Myalgia, arthralgia

Nervous system disorders: Severe exacerbation of disease after GILENYA discontinuation, posterior reversible encephalopathy syndrome, seizures including status epilepticus (see WARNINGS AND PRECAUTIONS)

Neoplasms, benign, malignant, and unspecified (incl cysts and polyps): melanoma, squamous cell carcinoma, Merkel cell carcinoma, Kaposi's sarcoma, B-cell lymphoma, T-cell lymphoma, CNS lymphoma, cutaneous T-cell lymphoma (including mycosis fungoides).

Because adverse reactions identified during post-marketing use are reported voluntarily from a population of uncertain size, it is not always possible to reliably estimate their frequency or to establish a causal relationship to drug exposure.

Abnormal Hematologic and Clinical Chemistry Findings

Liver function

Increased hepatic enzymes (mostly ALT elevation) have been reported in multiple sclerosis patients treated with GILENYA. In clinical trials in adults, patients treated with GILENYA experienced an asymptomatic elevation in serum levels of ALT, irrespective of adverse event

reporting. Three-fold or greater increases in ALT were seen in 8.5% of patients receiving GILENYA 0.5 mg compared to 1.7% of those on placebo while ≥ 5 -fold elevations were seen in 1.9% and 1.0% of patients, respectively, in the two-year placebo-controlled multiple sclerosis clinical trial. The majority of ALT elevations occurred within 6-9 months of initiating treatment with GILENYA. Findings were similar, but less frequent for AST and GGT.

ALT levels returned to normal after discontinuation of GILENYA within approximately 2 months. In a small number of patients (2 patients on GILENYA 0.5 mg), who experienced liver transaminase elevations of ≥ 5 x ULN and who continued on GILENYA therapy, the ALT levels returned to normal within approximately 5 months (see WARNINGS AND PRECAUTIONS, Hepatic/Biliary/Pancreatic).

Cholesterol and Triglycerides

In the 24 month placebo-controlled multiple sclerosis clinical trial D2301, total cholesterol and triglyceride levels were increased during treatment with GILENYA 0.5 mg from Week 2 to Month 24. The incidence of notable high cholesterol levels (> 6.21 mmol/L) was 39.6% for GILENYA 0.5 mg and 31.9% for placebo. The incidence of notable high triglyceride levels (> 3.39 mmol/L) was 13.7% for GILENYA 0.5 mg and 7.5% for placebo.

DRUG INTERACTIONS

Overview

Pharmacodynamic interactions

Anti-neoplastic, immunosuppressive or immune-modulating drugs: Co-administration of anti-neoplastic, immunosuppressive or immune modulating therapies is not recommended due to the risk of additive immune system effects. Caution should also be applied when switching patients from long-acting therapies with immune effects such as natalizumab, teriflunomide or mitoxantrone (see WARNINGS AND PRECAUTIONS, Immune).

Co-administration of a short course of corticosteroids (up to five days as per study protocol) to treat relapses did not increase the overall rate of infection in patients treated with fingolimod in the Phase III clinical trials, compared to placebo (see WARNINGS and PRECAUTIONS and ADVERSE REACTIONS). Patients should be reminded of the potential for increased risk of infection due to the risk of additive immune system effects of corticosteroids.

Heart rate lowering drugs: GILENYA (fingolimod) treatment results in PR interval prolongation during the first week and heart rate decrease during the first month of treatment. Due to potential additive effects on heart rate or cardiac conduction, GILENYA should not be used concomitantly with heart rate lowering drugs (e.g. antiarrhythmics, beta blockers, calcium channel blockers) (see WARNINGS AND PRECAUTIONS, Cardiovascular; ACTION AND CLINICAL PHARMACOLOGY, Pharmacodynamics-Heart rate and rhythm).

Fingolimod has been studied in combination with atenolol or diltiazem. When a single dose of fingolimod 5 mg/day was used with atenolol 50 mg/day (steady state) in an interaction study in healthy volunteers, there was an additional 15% reduction of heart rate at fingolimod treatment initiation, an effect not seen with diltiazem 240 mg/day (steady state).

GILENYA should not be initiated in patients receiving beta-blockers, heart-rate-lowering calcium channel blockers (such as verapamil or diltiazem), or other substances that may decrease heart rate (e.g. digoxin, cholinesterase inhibitors, or pilocarpine) because of the potential additive effects on heart rate. If treatment with GILENYA is considered necessary, advice from a cardiologist should be sought regarding the switch to a non heart-rate lowering drug or for appropriate monitoring (e.g., at least overnight monitoring) during treatment initiation, if the heart-rate-lowering drugs cannot be discontinued (see WARNINGS AND PRECAUTIONS, Cardiovascular).

QTc prolonging drugs: GILENYA may result in QTc prolongation during the first month of treatment (See WARNINGS AND PRECAUTIONS, Cardiovascular; ACTION AND CLINICAL PHARMACOLOGY, Pharmacodynamics-Thorough QT Study). GILENYA has not been studied in patients treated with drugs that prolong the QT interval.

Class Ia antiarrhythmics (e.g., quinidine, disopyramide) and Class III antiarrhythmics (e.g., amiodarone, sotalol) may prolong the QTc interval and have been associated with cases of torsades de pointes in patients with bradycardia and these drugs were excluded from use in multiple sclerosis clinical trials. Since initiation of GILENYA treatment results in both a decreased heart rate and a prolongation of QTc interval, GILENYA should not be used concomitantly with Class Ia or Class III drugs (see WARNINGS AND PRECAUTIONS, Cardiovascular-Bradyarrhythmia).

The initiation of treatment with GILENYA in a patient taking other types of QTc prolonging drugs should be avoided. If a decision is made to undertake treatment such patients should be evaluated by a cardiologist prior to initiation of treatment, to assess suitability and to determine the most appropriate monitoring, which should be at least overnight.

In addition to the Class Ia and Class III antiarrhythmic drugs, other drugs that have been associated with QTc interval prolongation and/or torsade de pointes include, but are not limited to, the examples found below. Chemical/ pharmacological classes are listed if some, although not necessarily all, class members have been implicated in QTc prolongation and/or torsade de pointes:

Class 1C antiarrhythmics (e.g., flecainide, propafenone); antipsychotics (e.g., chlorpromazine, haloperidol); antidepressants (e.g., fluoxetine, tricyclic/tetracyclic antidepressants e.g., amitriptyline, imipramine, maprotiline); opioids (e.g., methadone); macrolide antibiotics and analogues (e.g., erythromycin, clarithromycin, tacrolimus); quinolone antibiotics (e.g., ciprofloxacin); antimalarials (e.g., quinine, chloroquine); azole antifungals (e.g., ketoconazole); domperidone; 5-HT₃ receptor antagonists (e.g., ondansetron); tyrosine kinase inhibitors (e.g., sunitinib); histone deacetylase inhibitors (e.g., vorinostat); beta-2 adrenoceptor agonists (e.g., salmeterol).

Current information sources should be consulted for newly approved drugs that prolong the QT/QTc interval as well as for older drugs for which this effect has recently been established.

Vaccines: During and for up to 2 months after treatment with GILENYA vaccination may be less effective. The use of live attenuated vaccines may carry the risk of infection and should therefore also be avoided during GILENYA treatment and for up to 2 months after treatment with GILENYA (see WARNINGS AND PRECAUTIONS, Immune - Vaccination). It is recommended that pediatric patients be brought up to date with all immunizations in agreement with current immunization guidelines, as clinically indicated, prior to initiating GILENYA therapy.

Pharmacokinetic interactions

Fingolimod is primarily cleared *via* human cytochrome P450 4F2 (CYP4F2) and possibly other CYP4F isoenzymes. *In vitro* studies in hepatocytes indicated that CYP3A4 may contribute to fingolimod metabolism in the case of strong induction of CYP3A4.

Potential of fingolimod and fingolimod-phosphate to inhibit the metabolism of comedications

In vitro inhibition studies using pooled human liver microsomes and specific metabolic probe substrates demonstrated that fingolimod and fingolimod-phosphate have little or no capacity to inhibit the activity of CYP enzymes (CYP1A2, CYP2A6, CYP2B6, CYP2C8, CYP2C9, CYP2C19, CYP2D6, CYP2E1, CYP3A4/5, or CYP4A9/11 (fingolimod only)). Therefore, fingolimod and fingolimod-phosphate are unlikely to reduce the clearance of drugs that are mainly cleared through metabolism by the major CYP isoenzymes.

Potential of fingolimod and fingolimod-phosphate to induce its own and/or the metabolism of co-medications

Fingolimod was examined for its potential to induce human CYP3A4, CYP1A2, CYP4F2, and ABCB1 (P-gp or P-glycoprotein) mRNA and CYP3A, CYP1A2, CYP2B6, CYP2C8, CYP2C9, CYP2C19, and CYP4F2 activity in primary human hepatocytes. Fingolimod did not induce mRNA or activity of the different CYP enzymes and ABCB1 with respect to the vehicle control. Therefore, no clinically relevant induction of the tested CYP enzymes or ABCB1 (P-gp) by fingolimod is expected at therapeutic concentrations. *In vitro* experiments did not provide an indication of CYP induction by fingolimod-phosphate.

Potential of fingolimod and fingolimod-phosphate to inhibit the active transport of co-medications

Based on *in vitro* data, fingolimod as well as fingolimod-phosphate are not expected to inhibit the uptake of co-medications and/or biologics transported by the organic anion transporting polypeptides 1B1 and 1B3 (OATP1B1, OATP1B3) or the sodium taurocholate co-transporting polypeptide (NTCP). Similarly, they are not expected to inhibit the efflux of co-medications and/or biologics transported by the breast cancer resistance protein (BCRP), the bile salt export pump (BSEP), the multidrug resistance-associated protein 2 (MRP2) or P-glycoprotein (P-gp) at

therapeutic concentrations.

Drug-Drug Interactions

Oral contraceptives

In an open label two-period study, healthy female volunteers (n=31) on a steady regimen of oral contraceptive (ethinylestradiol and levonorgestrel) received the oral contraceptive alone for 14 days, followed by co-administration of the oral contraceptive and fingolimod 0.5 mg/day for an additional 14 days. The steady state co-administration of fingolimod and the oral contraceptive did not elicit any change in oral contraceptive exposure. Fingolimod and fingolimod-phosphate exposure were consistent with those from previous studies.

No interaction studies have been performed with oral contraceptives containing other progestogens, however an effect of fingolimod on their exposure is not expected.

Cyclosporine

The pharmacokinetics of single-dose fingolimod were not altered during co-administration with cyclosporine at steady-state, nor were cyclosporine (CYP3A4 substrate) steady-state pharmacokinetics altered by single-dose, or multi-dose (28 days) fingolimod administration. These data suggest that fingolimod is not likely to reduce or increase the clearance of drugs mainly cleared by CYP3A4 and that inhibition of CYP3A4 is unlikely to reduce the clearance of fingolimod. Potent inhibition of transporters P-gp, MRP2 and OATP1B1 does not influence fingolimod disposition.

Ketoconazole

In an open-label, two-period crossover study, healthy volunteers (N=22) received a single dose of 5 mg fingolimod on Day 1 of the first period and ketoconazole 200 mg twice daily for 9 days during the second period, with a single 5 mg dose of fingolimod administered on the fourth day of ketoconazole treatment. The co-administration of ketoconazole 200 mg twice daily at steady-state and a single dose of fingolimod 5 mg led to a 1.7-fold increase in the AUC of fingolimod and fingolimod-phosphate by inhibition of CYP4F2. This study did not evaluate the effect of chronic co-administration of ketoconazole, a potent inhibitor of CYP3A and CYP4F2, on fingolimod pharmacokinetics. Therefore, caution should be exercised during chronic co-administration of GILENYA and systemic ketoconazole and patients should be closely monitored as the risk of adverse events may be increased.

Isoproterenol and atropine

Single-dose fingolimod and fingolimod-phosphate exposure was not altered by co-administered isoproterenol, or atropine.

Carbamazepine

The co-administration of carbamazepine 600 mg twice daily at steady-state and a single dose of fingolimod 2 mg decreased the AUC of fingolimod and fingolimod-phosphate by approximately 40%. The clinical relevance of this decrease is unknown; however, the co-administration of carbamazepine may decrease the efficacy of fingolimod treatment.

Drug-Laboratory Interactions

Since fingolimod reduces blood lymphocyte counts via re-distribution in secondary lymphoid organs, peripheral blood lymphocyte counts cannot be utilized to evaluate the lymphocyte subset status of a patient treated with GILENYA.

Laboratory tests requiring the use of circulating mononuclear cells require larger blood volumes due to reduction in the number of circulating lymphocytes.

DOSAGE AND ADMINISTRATION

Dosing Considerations

See **WARNINGS AND PRECAUTIONS, Cardiovascular for complete information on patients with certain cardiovascular conditions in which GILENYA should not be used or which may require additional monitoring.**

Dosing in pediatric patients (aged 10 years to < 18 years of age) is dependent on weight (see DOSAGE AND ADMINISTRATION, Recommended Dose and Dosage Adjustment).

Conditions when GILENYA should not be used

- GILENYA should not be initiated in patients on concurrent therapy with beta-blockers, with heart-rate lowering calcium channel blockers or with other substances that may decrease heart rate. If treatment with GILENYA is considered necessary, advice from a cardiologist should be sought regarding a switch to drugs that do not lower heart rate or for appropriate monitoring during treatment initiation, if the heart-rate-lowering drugs cannot be discontinued (see **WARNINGS AND PRECAUTIONS, Cardiovascular-Bradyarrhythmia; DRUG INTERACTIONS-Heart rate lowering drugs**).
- The use of GILENYA with drugs that prolong the QT interval should be avoided. If a decision is made to undertake treatment such patients should be evaluated by a cardiologist prior to initiation of treatment, to assess suitability and to determine the most appropriate monitoring, which should be at least overnight (see **WARNINGS AND PRECAUTIONS, Cardiovascular-QTc prolongation; DRUG INTERACTIONS-QTc prolonging drugs**).

See WARNINGS AND PRECAUTIONS, Cardiovascular-Bradyarrhythmia for other conditions when GILENYA should not be used.

First dose monitoring of fingolimod

- For all patients, obtain an ECG and measure blood pressure prior to dosing and 6-hours after the first dose.
- Monitor all patients for signs and symptoms of bradyarrhythmia, with hourly pulse and blood pressure measurements, for at least 6 hours after the first dose.
- If symptoms of bradyarrhythmia or AV block occur, initiate appropriate management, with continued monitoring (e.g., continuous ECG) until the symptoms have resolved (see WARNINGS AND PRECAUTIONS, Cardiovascular, Bradyarrhythmia).

The same precautions as for the first dose should be taken when patients are switched from the 0.25 mg to the 0.5 mg daily dose.

See WARNINGS AND PRECAUTIONS, Cardiovascular-Bradyarrhythmia for additional recommendations for extended monitoring.

- Patients should be advised that the ability to drive an automobile or operate dangerous equipment may be impaired during the first day of treatment.
- Re-initiation of fingolimod after a treatment interruption of more than 2 weeks after the first month of treatment may produce the same effect on heart rate as the initial dose. Patients should be monitored as for the first dose. Within the first 2 weeks of treatment, first-dose procedures are recommended after an interruption of one day or more. During week 3 and 4 of treatment, first dose procedures are recommended after a treatment interruption of more than 7 days (see WARNINGS AND PRECAUTIONS, Cardiovascular-Re-initiation of therapy following discontinuation).

Dosing in special populations

- *Renal impairment:* GILENYA should be used with caution in patients with severe renal impairment (see ACTION AND CLINICAL PHARMACOLOGY, Pharmacokinetics-Special Populations and Conditions).
- *Hepatic impairment:* GILENYA is contraindicated in patients with severe hepatic impairment (Child-Pugh class C) (see CONTRAINDICATIONS). Although dose adjustments are not needed in patients with mild and moderate hepatic impairment, caution should be exercised when initiating GILENYA treatment in these patients (ACTION AND CLINICAL PHARMACOLOGY, Pharmacokinetics-Special Populations and Conditions; WARNINGS AND PRECAUTIONS, Hepatic/Biliary/Pancreatic-Liver Function).

- *Pediatric patients* (< 10 years of age): The safety and efficacy of GILENYA in pediatric patients below 10 years of age have not been studied. (see ACTION AND CLINICAL PHARMACOLOGY, Pharmacokinetics-Special Populations and Conditions).
- *Geriatric patients*: GILENYA should be used with caution in patients aged 65 years and over due to the greater frequency of reduced hepatic, renal, immune, pulmonary and cardiovascular function, other concomitant diseases and concomitant drug therapy (see CONTRAINDICATIONS; WARNINGS AND PRECAUTIONS, Special Populations; ACTION AND CLINICAL PHARMACOLOGY, Pharmacokinetics-Special Populations and Conditions).
- *Ethnicity*: No GILENYA dose adjustments are needed based on ethnic origin (see ACTION AND CLINICAL PHARMACOLOGY, Pharmacokinetics-Special Populations and Conditions).
- *Gender*: No GILENYA dose adjustments are needed based on gender (see ACTION AND CLINICAL PHARMACOLOGY, Pharmacokinetics-Special Populations and Conditions).
- *Diabetic patients*: GILENYA should be used with caution in patients with diabetes mellitus due to a potential increased risk of macular edema (see ADVERSE REACTIONS, Macular Edema). Multiple sclerosis patients with concomitant diabetes mellitus were excluded from the clinical trials with GILENYA.

Recommended Dose and Dosage Adjustment

In adults, the recommended dose of GILENYA is 0.5 mg once daily.

In pediatric patients (10 years to < 18 years of age), the recommended dose is dependent on body weight:

- *Pediatric patients with body weight \leq 40 kg*: 0.25 mg once daily taken orally.
- *Pediatric patients with body weight $>$ 40 kg*: 0.5 mg once daily taken orally.

Pediatric patients who start on 0.25 mg daily and subsequently reach a stable body weight above 40 kg should be switched to 0.5 mg daily. When switching from a 0.25 mg to a 0.5 mg daily dose, it is recommended to repeat the first dose observation.

Patients already on beta interferon or glatiramer acetate therapy can switch directly to GILENYA if they do not display signs of treatment-related abnormalities such as cytopenia. Caution is advised when switching patients from natalizumab or teriflunomide to GILENYA. For recommendations related to switching patients from other disease modifying therapies to GILENYA, see WARNINGS AND PRECAUTIONS: Immune - Prior treatment with immunosuppressive or immune-modulating therapies.

Missed Dose

If a dose is missed, treatment should be continued with the next dose as planned.

If the treatment is interrupted for one day or more during the first two weeks of treatment, first dose procedures are recommended upon reinitiation (see WARNINGS AND PRECAUTIONS, Cardiovascular – Re-initiation Therapy Following discontinuation).

If fingolimod therapy is discontinued for more than 2 weeks, after the first month of treatment, the effects on heart rate and AV conduction may recur on reintroduction of fingolimod treatment and the same precautions as for the first dose should apply (i.e., monitor for at least 6 hours after the first dose). Within the first 2 weeks of treatment, first-dose procedures are recommended after an interruption of one day or more. During weeks 3 and 4 of treatment, first dose procedures are recommended after a treatment interruption of more than 7 days.

Administration

GILENYA is taken orally, with or without food.

OVERDOSAGE

For management of a suspected drug overdose, contact your regional Poison Control Centre.

Single doses of fingolimod up to 40 mg (80-fold the recommended dose of 0.5mg) were well tolerated in healthy adult volunteers. Fingolimod doses of 5 mg to 40 mg were associated with a mild to moderate, dose dependent decrease in FEV1. At 40 mg, 5 of 6 subjects reported mild chest tightness or discomfort which was clinically consistent with small airway reactivity.

Fingolimod can induce bradycardia. The decline in heart rate usually starts within one hour of the first dose, and is maximal within 6 hours. There have been reports of slow atrioventricular conduction with isolated reports of transient, spontaneously resolving complete AV block (see WARNINGS AND PRECAUTIONS-Cardiovascular; and ADVERSE DRUG REACTIONS-Bradycardia, -Post Market Adverse Events).

In case of GILENYA overdosage, observe patients overnight with continuous ECG monitoring in a medical facility and obtain regular measurements of pulse rate and blood pressure (see DOSAGE AND ADMINISTRATION-Dosing Considerations; and WARNINGS AND PRECAUTIONS-Cardiovascular).

Neither dialysis nor plasma exchange results in removal of fingolimod from the body.

ACTION AND CLINICAL PHARMACOLOGY

Mechanism of Action

Fingolimod is metabolized by sphingosine kinase to the active metabolite fingolimod-phosphate. Fingolimod-phosphate, binds with high affinity to sphingosine 1-phosphate (S1P) receptors 1, 3, 4, and 5. Fingolimod-phosphate binding to S1P receptors on lymphocytes induces S1P receptor down-regulation on lymphocytes, and blocks the capacity of lymphocytes to egress from lymph nodes, reducing the number of lymphocytes in peripheral blood. The mechanism by which fingolimod exerts therapeutic effects in multiple sclerosis is not known, but may involve reduction of lymphocyte migration into the central nervous system.

Pharmacodynamics

Immune system

Effects on immune cell numbers in the blood. In a study in which 12 subjects were treated with GILENYA (fingolimod) 0.5 mg/day for 28 days, the mean lymphocyte count was decreased to approximately 70% of baseline within 4 hours after the first dose and approximately 50% within 8 hours. With continued daily dosing, the lymphocyte count continued to decrease over a 2-week period, reaching a nadir count of approximately 500 cells/ μ L or approximately 30% of baseline. Low lymphocyte counts are maintained with chronic daily dosing.

In the 2-year placebo-controlled multiple sclerosis clinical trial in which 425 patients were treated with GILENYA 0.5 mg and 418 patients received placebo, 18% of patients on 0.5 mg fingolimod reached a nadir below 200 cells/ μ L on at least one occasion. Approximately 4% of patients on 0.5 mg fingolimod had lymphocyte counts below 200 cells/ μ L on two or more consecutive tests separated by approximately 3 months, and for the majority of these patients lymphocyte counts remained at this level for at least 180 days. Treatment was interrupted when patients had confirmed lymphocyte counts below 200 cells/ μ L and lymphocyte counts were monitored frequently until levels returned to 600 cells/ μ L.

Peripheral lymphocyte count increases are evident within days of stopping fingolimod treatment. Because elimination of fingolimod after discontinuation of GILENYA may take up to 2 months (see ACTION AND CLINICAL PHARMACOLOGY, Pharmacokinetics), recovery of peripheral lymphocyte counts to baseline values is gradual. For patients in multiple sclerosis clinical trials who had lymphocyte count results available both at the end of treatment and during the 3-month interval following discontinuation of treatment, lymphocyte counts returned to normal values within 3 months of discontinuing treatment. Delayed recovery, beyond 3 months, of lymphocyte counts was uncommon and showed a potential correlation with higher doses of fingolimod, the occurrence of lymphocyte counts $< 0.2 \times 10^9/L$ while on treatment, and longer duration of exposure to fingolimod.

Chronic fingolimod dosing leads to a mild decrease in the neutrophil count to approximately 80% of baseline. Monocytes are unaffected by fingolimod.

Effect on antibody response. Immunologic responses are decreased during treatment with GILENYA 0.5 mg. The immunogenicity of keyhole limpet Hemocyanin (KLH) and pneumococcal polysaccharide vaccine (PPV-23) immunization were assessed by IgM and IgG titers in a steady-state, randomized, placebo-controlled study in healthy volunteers. Compared to placebo, antigen-specific IgM titers were decreased by 91% and 25% in response to KLH and PPV, respectively, in subjects on GILENYA 0.5 mg. Similarly, IgG titers were decreased by 45% and 50%, in response to KLH and PPV, respectively, in subjects on GILENYA 0.5 mg daily compared to placebo. The responder rate for GILENYA 0.5 mg as measured by the number of subjects with a >4-fold increase in KLH IgG was comparable to placebo and 25% lower for PPV-23 IgG, while the number of subjects with a >4 fold increase in KLH and PPV-23 IgM was 75% and 40% lower, respectively, compared to placebo. The capacity to mount a skin delayed-type hypersensitivity reaction to *Candida* and tetanus toxoid was decreased by approximately 30% in subjects on GILENYA 0.5 mg daily, compared to placebo. Immunologic responses were further decreased with fingolimod 1.25 mg (a dose higher than recommended in multiple sclerosis).

In the second study, the immunogenicity of Northern hemisphere seasonal influenza and tetanus toxoid vaccination was assessed in a 12-week steady-state, randomized, placebo-controlled study of GILENYA 0.5 mg in adult multiple sclerosis patients (n = 136). The responder rate 3 weeks after vaccination, defined as seroconversion or a ≥ 4 -fold increase in antibody directed against at least 1 of the 3 influenza strains, was 54% for GILENYA 0.5 mg and 85% in the placebo group. The responder rate 3 weeks after vaccination, defined as seroconversion or a ≥ 4 -fold increase in antibody directed against tetanus toxoid was 40% for GILENYA 0.5 mg and 61% in the placebo group.

Heart rate and rhythm

Fingolimod causes a reversible prolongation of PR interval and reduction in heart rate upon treatment initiation (see ADVERSE REACTIONS). The maximum decline in heart rate is seen in the first 6 hours post dose, with 70% of the negative chronotropic effect achieved on the first day. Heart rate progressively returns to baseline values within 1 month of chronic treatment.

Autonomic responses of the heart, including diurnal variation of heart rate and response to exercise are not affected by fingolimod treatment.

With initiation of fingolimod treatment there is an increase in atrial premature contractions, but there is no increased rate of atrial fibrillation/flutter, ventricular arrhythmias or ectopy. Fingolimod treatment is not associated with a decrease in cardiac output.

The decrease in heart rate induced by fingolimod can be reversed by atropine, isoproterenol (isoprenaline) or salmeterol.

Thorough QT Study

In a placebo-controlled, double-blind, parallel group study, healthy volunteers were randomized to receive placebo (N=55), fingolimod 1.25 mg (N=53), or fingolimod 2.5 mg (N=61) for 7 days. A loading dose procedure was used to enable steady-state to be reached more quickly. The therapeutic 0.5 mg dose was not studied. Serial ECG recordings were performed for 12 h at baseline and on day 7. Fingolimod was associated with statistically significant QTc prolongation at all time points on day 7, with a maximum effect of 10.9 msec (90% CI 7.88, 13.91) at 6 h post-dosing in the fingolimod 1.25 mg group and 11.1 ms (90% CI 7.56, 14.62) at 6 h post-dosing in the fingolimod 2.5 mg group.

Blood Pressure

Acute dosing with fingolimod resulted in statistically significant decreases in standing systolic and diastolic blood pressure from 2-14 h on Day 1 dosing. The maximum decrease in standing systolic and diastolic blood pressure was -9.5 and -7.6 mmHg respectively at 6 h post-dosing in the fingolimod 1.25 mg treatment group. The therapeutic 0.5 mg dose was not studied. *Chronic dosing* led to statistically significant increases in systolic and diastolic blood pressure on day 28. (see WARNINGS AND PRECAUTIONS, Cardiovascular; ADVERSE REACTIONS, Blood Pressure).

Pulmonary function

Single doses of fingolimod ≥ 5 mg (10-fold the recommended dose) are associated with a dose-dependent increase in airway resistance. In a 14-day study of 0.5, 1.25, or 5 mg/day, fingolimod was not associated with impaired oxygenation or oxygen desaturation with exercise or an increase in airway responsiveness to methacholine. Subjects on fingolimod treatment had a normal bronchodilator response to inhaled beta-agonists.

In a placebo-controlled study of subjects with moderate asthma but without multiple sclerosis given fingolimod at doses 0.5mg, 1.25 mg and 2.5 mg or placebo for 10 days (n=9 subjects/group), a significant 10% reduction in mean time-matched, baseline-corrected AUEC FEV1 for the period of 0 to 6 hours after dosing on Day 10 was observed in patients receiving fingolimod 1.25 mg (2.5-times the recommended dose). Changes in FEV1 in the fingolimod 0.5mg and 2.5mg dose groups were, however, not statistically different from those observed in the placebo group. Fingolimod 1.25 mg however was associated with a 5-fold increase in the use of rescue short acting beta-agonists. There was a 2-fold increase (not statistically significant) in the use of rescue short-acting agonists in the fingolimod 0.5 mg group.

Pharmacokinetics

Absorption: The pharmacokinetic parameters of GILENYA 0.5 mg after a single dose and at steady-state are displayed in the table below.

	Fingolimod		Fingolimod-P	
	Single dose	Steady-state	Single dose	Steady-state
T _{max} , h	12	12	6	6
C _{max} , ng/mL	0.42	3.66	0.45	1.81
AUC _{0-24h} , ng.h/mL	7.84	76.1	6.1	33.1

Values are mean, except T_{max} (median)

Fingolimod absorption is slow (T_{max} of 12-16 hours) and extensive (≥85%, based on the amount of radioactivity excreted in urine and the amount of metabolites in feces extrapolated to infinity). The apparent absolute oral bioavailability is 93%.

Food intake does not alter C_{max} or exposure (AUC) of fingolimod or fingolimod-phosphate. The time to reach maximum drug concentration in blood plasma (T_{max}) is increased when GILENYA is taken with food. GILENYA may be taken without regard to meals (see DOSAGE AND ADMINISTRATION).

Steady-state blood concentrations are reached within 1 to 2 months of once-daily administration, and steady-state levels are approximately 10-fold greater than with the initial dose.

Distribution: Fingolimod highly distributes in red blood cells, with the fraction in blood cells of 86%. Fingolimod-phosphate has a smaller uptake in blood cells of <17%. Fingolimod and fingolimod-phosphate are highly protein bound (>99.7%). Fingolimod and fingolimod-phosphate protein binding is not altered by renal or hepatic impairment.

Fingolimod is extensively distributed to body tissues with a volume of distribution of about 1200±260 L.

Metabolism: The biotransformation of fingolimod in humans occurs by three main pathways; by reversible stereoselective phosphorylation to the pharmacologically active (*S*)-enantiomer of fingolimod-phosphate, by oxidative biotransformation catalyzed mainly by CYP4F2 and possibly other CYP4F isoenzymes and subsequent fatty acid-like degradation to inactive metabolites, and by formation of pharmacologically inactive non-polar ceramide analogs of fingolimod.

Following single oral administration of [¹⁴C] fingolimod, the major fingolimod-related components in blood, as judged from their contribution to the AUC up to 816 hours post-dose of total radio-labeled components, are fingolimod itself (23.3%), fingolimod-phosphate (10.3%), and inactive metabolites (M3 carboxylic acid metabolite (8.3%), M29 ceramide metabolite (8.9%) and M30 ceramide metabolite (7.3%)).

Excretion: Fingolimod blood clearance is 6.3±2.3 L/h, and the average apparent terminal half-life (t_{1/2}) is 6-9 days. Blood levels of fingolimod-phosphate decline in parallel with fingolimod in the terminal phase yielding similar half-life for both.

After oral administration, about 81% of the dose is slowly excreted in the urine as inactive metabolites. Fingolimod and fingolimod-phosphate are not excreted intact in urine but are the major components in the feces with amounts representing less than 2.5% of the dose each. After 34 days, the recovery of the administered dose is 89%.

Special Populations and Conditions

Pediatrics: Fingolimod-phosphate concentration at steady state is similar in adult and pediatric patients.

The median fingolimod-phosphate (fingolimod-P) concentration in pediatric MS patients aged 10 to less than 18 years was 1.10 ng/mL, as compared to 1.35 ng/mL in adult MS patients.

In pediatric patients, fingolimod-phosphate concentrations increase in an apparent dose proportional manner after multiple once daily doses of fingolimod 0.25 mg or 0.5 mg.

Fingolimod-phosphate steady state concentrations decreased with increasing weight.

The safety and efficacy of GILENYA in patients below the age of 10 have not been studied.

Geriatrics: Clinical studies of GILENYA did not include sufficient numbers of patients aged 65 years and over to determine whether the safety and efficacy of GILENYA differs in elderly patients compared to younger patients. Due to the greater frequency of reduced hepatic, renal, immune, pulmonary and cardiovascular function, other concomitant diseases and concomitant drug therapy, treatment with GILENYA merits caution and may necessitate additional or more frequent monitoring in geriatric patients.

Gender: Gender has no influence on fingolimod and fingolimod-phosphate pharmacokinetics.

Race: The effects of ethnic origin on fingolimod and fingolimod phosphate pharmacokinetics are not of clinical relevance.

Hepatic Insufficiency: The pharmacokinetics of single-dose fingolimod (1 or 5 mg), when assessed in subjects with mild, moderate or severe hepatic impairments (Child-Pugh class A, B, and C), showed no change on fingolimod C_{max} , but an increase in AUC by 12%, 44% and 103%, respectively. The apparent elimination half-life is unchanged in mild hepatic impairment but is prolonged by 49-50% in moderate and severe hepatic impairment. The rate of lymphocyte count recovery was approximately 4-fold slower in the subjects with severe hepatic impairment compared to subjects with normal hepatic function. GILENYA is contraindicated in patients with severe hepatic impairment (Child-Pugh class C) (see CONTRAINDICATIONS and WARNINGS AND PRECAUTIONS, Special Populations). GILENYA should be used with caution in patients with mild and moderate hepatic impairment (Child-Pugh classes A and B). It is not known if patients with hepatic impairment are at increased risk of developing elevated liver function tests, more severe liver injury or other adverse events during treatment with GILENYA.

Renal Insufficiency: Severe renal impairment increases fingolimod C_{max} and AUC by 32% and 43%, respectively, and fingolimod-phosphate C_{max} and AUC by 25% and 14%, respectively. The apparent elimination half-life is unchanged for both analytes. Exposure to fingolimod metabolites was markedly increased, as shown by a 14-fold increase in AUC for the metabolite M3. The clinical significance of such increase in exposure is not known because the toxicity of this metabolite has not been fully characterized.

Caution is recommended when using GILENYA in patients with severe renal impairment (see WARNINGS AND PRECAUTIONS, Special Populations).

The pharmacokinetics of fingolimod and its metabolites in subjects with mild or moderate renal impairment have not been evaluated.

STORAGE AND STABILITY

Store at 15 - 25°C; protect from moisture.

GILENYA (fingolimod) must be kept out of the reach and sight of children.

DOSAGE FORMS, COMPOSITION AND PACKAGING

GILENYA (fingolimod) is supplied as hard capsules containing 0.25 mg or 0.5 mg fingolimod (as hydrochloride).

The 0.5 mg capsules have a white opaque body and bright yellow opaque cap; radial imprint with black ink, “FTY 0.5 mg” on cap and two radial bands imprinted on the body with yellow ink. Available in cartons of 7 (1 blister card of 7 capsules; physician sample) or 28 capsules (2 blisters cards of 14 capsules).

The 0.25 mg capsules have an ivory opaque body and cap, with black radial imprint “FTY 0.25 mg” on the cap and a black radial band on the capsule body. Available in cartons 28 capsules (2 blisters cards of 14 capsules).

0.5 mg hard capsules non-medicinal ingredients: magnesium stearate, mannitol; capsule shell contains: gelatin, titanium dioxide, yellow iron oxide.

0.25 mg hard capsules non-medicinal ingredients: mannitol, hydroxypropylcellulose, hydroxypropylbetadex, magnesium stearate; capsule shells contain: gelatin, titanium dioxide, iron oxide yellow.

PART II: SCIENTIFIC INFORMATION

PHARMACEUTICAL INFORMATION

Drug Substance

Common name: Fingolimod hydrochloride

Chemical name: 2-amino-2[2-(4-octylphenyl)ethyl]propane-1,3-diol hydrochloride

Molecular formula and molecular mass: $C_{19}H_{33}NO_2 \cdot HCl$
343.93

Structural formula:

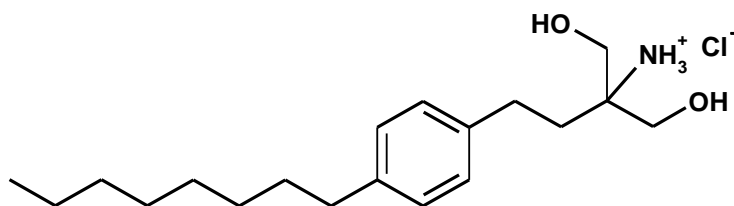

Physicochemical properties: Description: White to practically white powder

Solubility: Freely soluble in water.

pH value: pH of 1% solution in water at 22° to 25°C is 4.0.

CLINICAL TRIALS

Study demographics and trial design

Table 2 –Summary of adult patient demographics for clinical trials in RRMS

Study #	Trial design	Dosage, route of administration and duration	Study subjects (n=number)	Mean age (Range)	Gender
Study D2301 (FREEDOMS)	Randomized, double-blind, placebo-controlled study.	GILENYA 0.5 mg or 1.25 mg, or placebo, once-daily (oral). 2-year study.	GILENYA 0.5 mg: n=425 GILENYA 1.25 mg: n=429 Placebo: n=418	37.1 (17-55 years)	Male: 30.1 % Female: 69.9 %

Study D2302 (TRANSFORMS)	Randomized, double-blind, double-dummy, active (interferon beta-1a, 30 µg IM once weekly, Avonex)-controlled study.	GILENYA 0.5 mg or 1.25 mg, once-daily (oral), or Avonex 30µg, once-weekly (IM). 1-year study.	GILENYA 0.5 mg: n=429 GILENYA 1.25 mg: n=420 Avonex: n=431	36.2 (18-55 years)	Male: 32.7 % Female: 67.3 %
-----------------------------	---	--	--	--------------------	--------------------------------

Table 3 –Summary of pediatric patient demographics for RMS clinical trial

Study #	Trial design	Dosage, route of administration and duration	Study subjects (n=number)	Mean age (Range)	Gender
Study D2311 (PARADIGMS)	Randomized, double-blind, active (interferon beta-1a, 30 µg IM once weekly, Avonex)-controlled study.	GILENYA 0.25 mg or 0.5 mg, once-daily (oral), or Avonex 30µg, once-weekly (IM). 1-year study	GILENYA 0.25 mg: and GILENYA 0.5 mg: n=107 Avonex: n=108	15.3 (10-18 years)	Male: 37.7 % Female: 62.3 %

The efficacy of GILENYA (fingolimod) has been demonstrated in two studies evaluating once daily doses of GILENYA 0.5 mg and 1.25 mg in adult patients with relapsing-remitting multiple sclerosis. Both studies included patients who had experienced at least 2 clinical relapses during the 2 years prior to randomization or at least 1 clinical relapse during the 1 year prior to randomization, and had an Expanded Disability Status Scale (EDSS) score between 0 to 5.5.

The efficacy and safety of once-daily doses of GILENYA 0.25 mg or 0.5 mg (dose selected based on body weight and exposure measurements) have also been established in pediatric patients aged 10 to <18 years old with relapsing multiple sclerosis.

Study D2301 (FREEDOMS)

The FREEDOMS study was a 2-year randomized, double-blind, placebo-controlled Phase III study in patients with relapsing-remitting multiple sclerosis who had not received any interferon beta or glatiramer acetate for at least the previous 3 months and had not received any natalizumab for at least the previous 6 months. Neurological evaluations were performed at Screening, every 3 months and at the time of suspected relapse. MRI evaluations were performed at Screening, month 6, month 12 and month 24. The primary endpoint was the annualized relapse rate (ARR).

Median age was 37 years, median disease duration was 6.7 years and median EDSS score at baseline was 2.0. Approximately 40% of patients had received treatment with other disease modifying therapies prior to entering the study, with interferon-beta being the most commonly used

prior treatment (used by 29% of all patients). Patients were randomized to receive fingolimod 0.5 mg (n=425) or fingolimod 1.25 mg (n=429), or placebo (n=418) for up to 24 months. Median time on study drug was 717 days on 0.5 mg, 715 days on 1.25 mg and 718.5 days on placebo.

The primary endpoint, the annualized relapse rate was significantly lower in patients treated with GILENYA than in patients who received placebo, with a relative reduction in relapse of 54% for patients treated with GILENYA 0.5 mg. The key secondary endpoint was the time to 3-month confirmed disability progression, as measured by a 1-point increase from baseline in EDSS (0.5 point increase for patients with baseline EDSS of 5.5) sustained for 3 months. Time to onset of 3-month sustained disability progression was significantly delayed with GILENYA treatment compared to placebo. The 1.25 mg dose did not provide additional benefit over the 0.5 mg dose. Results for the Intent to Treat (ITT) analysis of primary and key secondary endpoints of the FREEDOMS study are shown in Table 3 and Figure 1.

Table 4. FREEDOMS study results

	GILENYA 0.5 mg N=425	Placebo N=418	p-value
Primary endpoint			
Annualized relapse rate [†]	0.18	0.40	<0.001
Key secondary endpoint			
Kaplan-Meier estimate of percentage (SE) of patients free of 3-month confirmed disability progression at Month 24	82.3 (1.89)	75.9 (2.17)	0.026
Hazard ratio of disability progression (95% CI)	0.70 (0.52, 0.96)		0.024

[†] Based on confirmed relapses. Relapse was defined as neurologic symptoms together with an increase ≥ 0.5 in the total EDSS score, or an increase of 1 point in each of two EDSS functional system scores, or an increase of two points in one EDSS functional system score (excluding bowel-bladder or cerebral functional systems). P-value determined by negative binomial regression adjusting for treatment, pooled country, number of relapses in previous 2 years and baseline EDSS.

Figure 1 Time to 3-month *confirmed* disability progression – Study D2301 (ITT population)

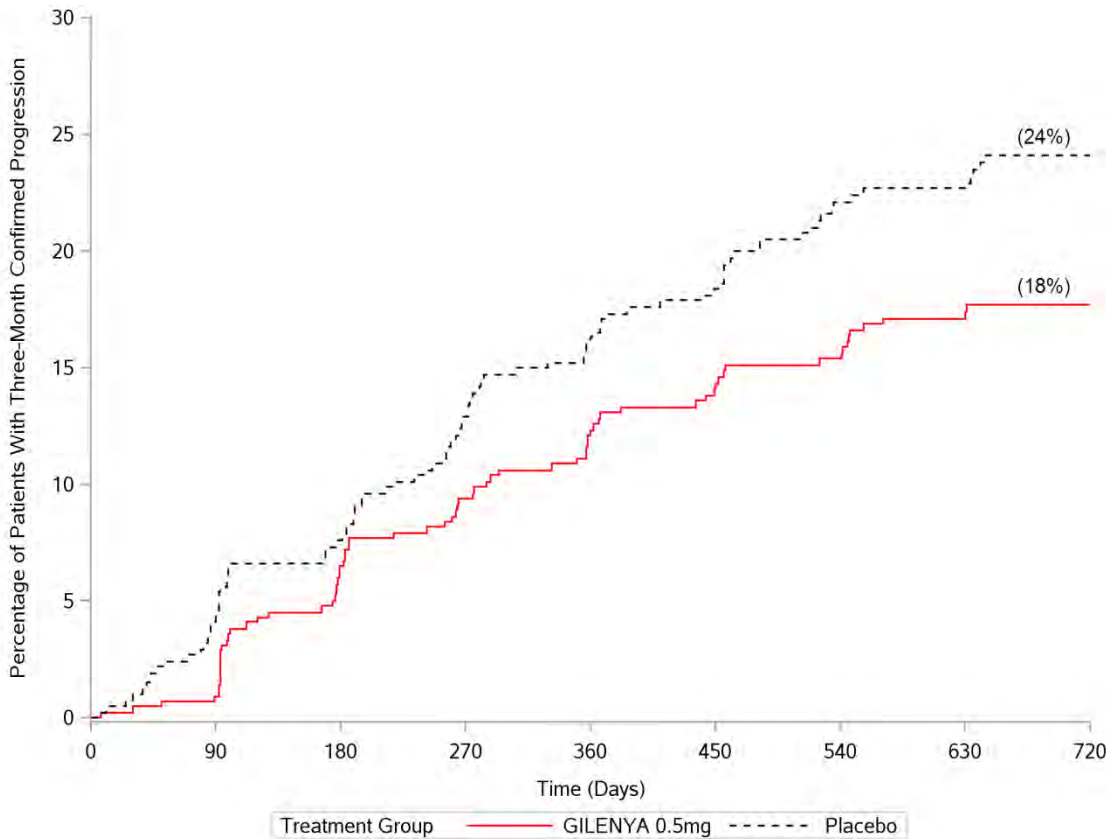

$p = 0.026$ for GILENYA vs. placebo.

The time to disability progression was significantly longer with GILENYA vs. placebo.

Secondary MRI endpoints included new and enlarging (active) T2 lesion counts, T1 Gadolinium (Gd)-enhancing lesion count and the rate of brain atrophy. The mean number of active T2 lesions over 24 months was 2.5 for GILENYA 0.5 mg and 9.8 for placebo ($p < 0.001$), representing a 74% relative reduction. The mean number of Gd-enhancing lesions at Month 24 was 0.2 for GILENYA compared to 1.1 for placebo ($p < 0.001$), a relative reduction of 81%. The rate of brain atrophy (mean % change in total brain volume) was less with GILENYA (-0.8%) than with placebo (-1.3%) over 24 months ($p < 0.001$). Changes in brain volume were also significant at Months 6 and 12.

Study D2302 (TRANSFORMS)

The TRANSFORMS study was a 1-year randomized, double-blind, double-dummy, active (interferon beta-1a)-controlled Phase III study in patients with relapsing-remitting multiple sclerosis who had not received any natalizumab in the previous 6 months. Prior treatment with

interferon-beta or glatiramer acetate up to the time of randomization was permitted.

Neurological evaluations were performed at Screening, every 3 months and at the time of suspected relapses. MRI evaluations were performed at Screening and at month 12. The primary endpoint was the annualized relapse rate.

Median age was 36 years, median disease duration was 5.9 years and median EDSS score at baseline was 2.0. Approximately 57% of patients had received treatment with other disease modifying therapies prior to entering the study, with interferon-beta being the most commonly used prior treatment (used by 49% of all patients). Patients were randomized to receive fingolimod 0.5 mg (n=429) or 1.25 mg (n=420) or interferon beta-1a 30 micrograms via the intramuscular route once weekly (n=431) for up to 12 months. Median time on study drug was 365 days on 0.5 mg, 364 days on 1.25 mg and 361 days on interferon beta-1a.

The annualized relapse rate was significantly lower in patients treated with GILENYA than in patients who received interferon beta-1a, with a relative reduction in relapse of 52% for patients treated with GILENYA. The 1.25 mg dose did not provide additional benefit over the 0.5 mg dose.

The key secondary endpoints were the number of new or newly enlarging T2 lesions and the time to onset of 3-month confirmed disability progression as measured by at least a 1-point increase from baseline in EDSS (0.5 point increase for those with baseline EDSS of 5.5) sustained for 3 months. The number of new or newly enlarging T2 lesions was significantly lower in patients treated with GILENYA than in patients who received interferon beta-1a. There was no significant difference in the time to 3-month confirmed disability progression between GILENYA and interferon beta-1a-treated patients at 1 year. There were no significant differences between the 0.5 mg and the 1.25 mg doses on either endpoint. Results for the primary and key secondary endpoints of this study are shown in Table 4.

Table 5. TRANSFORMS study results

	GILENYA 0.5 mg N=429	Interferon-beta-1a 30 µg N=431	p-value
Primary endpoint Annualized relapse rate ¹	0.16	0.33	<0.001
Key secondary endpoints			
MRI Mean (median) number of new or newly enlarging T2 lesions over 12 months ²	1.6 (0)	2.6 (1.0)	0.002
3-month confirmed disability progression Kaplan-Meier estimate of percentage (SE) of patients free of 3-month confirmed disability progression at Month 12	94.1 (1.25)	92.1 (1.33)	0.24
Hazard ratio of disability progression (95% CI)	0.71 (0.42, 1.21)		0.21

¹ Based on confirmed relapses. Relapse was defined as neurologic symptoms together with an increase ≥ 0.5 in the total EDSS score, or an increase of 1 point in each of two EDSS functional system scores, or an increase of two points in one EDSS functional system score (excluding bowel-bladder or cerebral functional systems). P-value determined by negative binomial regression adjusting for treatment, country, number of relapses in previous 2 years and baseline EDSS.

² Statistical analysis using negative binomial regression adjusted for treatment, country, number of relapses in previous 2 years and baseline EDSS.

Other secondary endpoints included the proportion of patients remaining relapse-free, T1 Gd-enhancing lesion count and the rate of brain atrophy. The proportion of patients remaining relapse-free after 12 months was 83% for GILENYA 0.5mg and 70% for those receiving interferon beta-1a ($p<0.001$). The mean number of Gd-enhancing lesions at Month 12 was 0.2 for GILENYA compared to 0.5 for interferon beta-1a ($p<0.001$), a relative reduction of 60%. The rate of brain atrophy (mean % change in total brain volume) was less with GILENYA (-0.3%) than with interferon beta-1a (-0.5%) over 12 months ($p<0.001$).

Pooled results of studies D2301 and D2302 showed a consistent reduction of annualized relapse rate compared to comparator in subgroups defined by gender, age, prior multiple sclerosis therapy, disease activity or disability levels at baseline.

Study D2311 (PARADIGMS) in pediatric patients 10 years to < 18 years of age

The PARADIGMS study was a double-blind, randomized, active-controlled, parallel-group, multicenter study with flexible duration up to 24 months, to evaluate the efficacy and safety of fingolimod compared to interferon beta-1a in pediatric patients with multiple sclerosis, aged 10 to <18 years old. Prior therapy with interferon-beta, dimethyl fumarate or glatiramer acetate up to the time of randomization was permitted. Neurological evaluations were performed at screening, every

3 months and at the time of suspected relapses. MRI evaluations were performed at screening, and every 6 months throughout the study. The primary endpoint was the annualized relapse rate (ARR).

Median age was 16 years, median disease duration since first symptom was 1.5 years and median EDSS score at baseline was 1.5. The majority of patients had achieved pubertal status (Tanner staging score ≥ 2) at the time of randomization. Patients were randomized to receive fingolimod or interferon beta-1a via the intramuscular route once weekly for up to 24 months. Median time on study drug was 634 days on fingolimod and 547 days on interferon beta-1a.

The primary endpoint, the annualized relapse rate, was significantly lower in patients treated with fingolimod than in patients who received interferon beta-1a (relative reduction in ARR of 81.9%). The key secondary endpoint, the annualized rate of the number of new or newly enlarged T2 lesions up to Month 24, was also significantly lower in patients treated with fingolimod than in patients who received interferon beta-1a.

The results for the primary and key secondary endpoint are shown in Table 6.

Table 6. PARADIGMS study results

	Fingolimod 0.25 mg or 0.5 mg N=107	Interferon beta-1a IM 30 µg N=107[#]	p-value
Primary endpoint			
Annualized relapse rate	0.122	0.675	p<0.001*
Relative reduction (percent)	81.9		
Key secondary endpoints			
MRI			
Annualized rate of the number of new or newly enlarging T2 lesions	N=106	N=102	
Adjusted mean	4.393	9.269	p<0.001*
Relative Reduction (percent)	52.6		

All analyses of clinical endpoint were on full analysis set. MRI analyses used the evaluable dataset.

[#] One patient was randomized to receive Interferon beta-1a IM, 30 µg weekly, but was unable to swallow the double dummy medication and discontinued from the study. This patient was excluded from the full analysis and safety set.

* Indicates statistical significance vs. Interferon beta-1a IM at two-sided 0.05 level.

Determination of p-values: aggregate ARR by negative binomial regression adjusting for treatment, region, pubertal status (the stratification factor in interactive voice response system, IVRS), Annualized rate of number of new/newly enlarging T2 lesions by negative binomial regression adjusted for treatment, region, pubertal status (the stratification factor in IVRS), and baseline T2 lesion number (offset: time in study).

Other secondary endpoints included the proportion of patients remaining relapse-free, T1 Gd-enhancing lesion count and the rate of brain atrophy. The proportion of patients remaining relapse-free after 24 months was 85.7% for fingolimod and 38.8% for those receiving interferon beta-1a (p<0.001). The mean number of Gd-enhancing T1 lesions per scan up to Month 24 was 0.436 for fingolimod compared to 1.282 for placebo (p<0.001), a relative reduction of 66%. The annualized

rate of brain atrophy from baseline up to Month 24 (least square mean) was significantly reduced with fingolimod (-0.48) compared to interferon beta-1a (-0.8) (p=0.014).

DETAILED PHARMACOLOGY

Mechanism of Action

Fingolimod-phosphate binding to S1P receptors on lymphocytes causes internalization and functional antagonism of S1P receptors. This reduces S1P-dependent egress of lymphocytes from lymphoid organs and, in animals reduces the numbers of autoreactive cells that invade the CNS. Studies in animals and *in vitro* studies indicate that fingolimod can penetrate the CNS and may also act via interaction with S1P receptors on neural cells.

Non-Clinical Pharmacokinetics

Pharmacokinetics and disposition of fingolimod, its metabolites, and fingolimod-phosphate (in the form of its (*S*)- and (*R*)-enantiomers AML629 and AML627, respectively) were investigated in mice, rats, rabbits, dogs and cynomolgus monkeys.

Fingolimod and fingolimod-phosphate were major drug-related components across all species including human. The fate of fingolimod and fingolimod-phosphate appears to be similar in all species investigated including man. Fingolimod-phosphate was present exclusively in the form of the (*S*)-enantiomer. The absolute oral bioavailability of fingolimod was high or up to complete in animals and humans. Systemic exposure to fingolimod was generally dose proportional with no gender differences. Fingolimod accumulated in the brain of rats, and dogs, and in the brain and lung of cynomolgus monkeys after multiple oral dosing. After discontinuation of dosing, fingolimod was slowly eliminated from the rat and monkey brain.

The biotransformation of fingolimod in animals and human occurred by three main pathways: (*i*) by reversible stereoselective phosphorylation to the (*S*)-enantiomer of fingolimod-phosphate, (*ii*) by hydroxylation at the terminal methyl group of the octyl chain (catalyzed predominantly by CYP4F2), followed by rapid further oxidation to the carboxylic acid metabolite which undergoes further biotransformation by β -oxidation-like losses of two carbon units to other carboxylic acid metabolites, (*iii*) formation of non-polar ceramide analogs of fingolimod. Essentially the same metabolites of fingolimod in humans were formed by at least one of the animal species *in vivo* and/or *in vitro*, supporting the selection of the toxicological test species.

Fingolimod was eliminated predominantly by oxidative metabolism (CYP4F2). Fingolimod-phosphate appeared to be eliminated mainly by de-phosphorylation back to fingolimod. Direct oxidation of fingolimod-phosphate does not appear to occur to a significant extent across species including human. Renal excretion of unchanged fingolimod was not observed. Fecal excretion of unchanged fingolimod and fingolimod-phosphate was minor.

The involvement of multiple cytochrome P450 isoenzymes in the oxidation of fingolimod suggests that the metabolism of fingolimod may not be readily inhibited completely by a single specific CYP inhibitor. The potential for drug-drug interactions between fingolimod and co-medications *via* cytochrome P450 enzymes, and *via* hepatic uptake and efflux transport systems appears low. Fingolimod and AML629 are not expected to inhibit cytochrome P450-mediated metabolic clearance of co-medications. Fingolimod does not induce its own liver drug metabolizing enzymes or those of potential co-medications.

Safety Pharmacology

A slight inhibition of hERG (25% or 18%) was present at the solubility limit of fingolimod or of the pharmacologically active S-enantiomer (0.5 μ M or 0.4 μ M) in stably transfected HEK293 cells.

In the Langendorff perfused rabbit heart model, fingolimod-phosphate increased cycle length and reduced coronary perfusion at target concentrations between 10 nM and 100 nM.

Oral fingolimod at 10 mg/kg induced significant decreases in heart rate, and increases in systolic and diastolic blood pressure in conscious, free-moving male cynomolgus monkeys.

Intravenous administration of the pharmacologically active S-enantiomer of fingolimod-phosphate decreased heart rate, decreased blood pressure, prolonged the PR interval, and caused sinus arrhythmias at doses of 0.01 and 0.1 mg/kg in anesthetized guinea pigs. The decrease in heart rate and prolongation of the PR interval caused by the S-enantiomer of fingolimod-phosphate were inhibited by pertussis toxin, suggesting the involvement of a *G* α i/o-coupled S1P receptor.

In anesthetized rats intravenous fingolimod-phosphate decreased the heart rate and produced sinus arrhythmias at 0.3 mg/kg, prolonged the PR interval and decreased the respiratory tidal volume at doses greater than 0.03 mg/kg, and decreased respiratory minute volume at 0.03 mg/kg. Pertussis toxin inhibited the fingolimod-phosphate-induced decrease in heart rate, prolongation in PR interval, AV block and decrease in respiratory tidal volume.

Dyspnea, bradycardia and ECG findings of sino-atrial block, atrioventricular block, findings resembling left bundle branch block, atrial premature complexes, and ventricular premature complexes were present at 0.1 and/or 0.5 mg/kg in rats intravenously administered the pharmacologically active S-enantiomer of fingolimod-phosphate.

In dogs, by step-wise increasing the daily oral dose of fingolimod from 0.1 to 10 mg/kg, the decrease in heart rate and increase in blood pressure were less pronounced compared with giving an oral dose of \geq 2.5 mg/kg on Day 1. An increase in frequency of AV block and ventricular premature contractions occurred in dogs given 10 mg/kg fingolimod orally.

Intravenous fingolimod (3 and 10 mg/kg) induced a marked and long-lasting increase in airway resistance in anesthetized rats. Pretreatment with *B. pertussis* toxin resulted in a reduction of the acute bronchoconstriction suggesting that the acute effects caused by fingolimod occur via signaling pathways involving Gi-GTP-binding protein.

Bronchoconstriction induced in anesthetized rats by IV injection of fingolimod was reversed by injection of the beta-2 adrenoceptor agonist, salbutamol.

TOXICOLOGY

The preclinical safety profile of fingolimod was assessed in mice, rats, dogs and monkeys.

Fingolimod had a moderate level of acute toxicity. Deaths occurred following single dose IV administration of 50 mg/kg in mice and ≥ 25 mg/kg IV in rats, and following single dose oral administration of ≥ 300 mg/kg in rats. No deaths occurred in dogs after single oral doses of 1000 or 2000 mg/kg. Signs of acute toxicity were referable to respiratory, CNS and gastrointestinal systems and included dyspnea, uncoordination, tremors, convulsions, sedation and decreased locomotor activity and forestomach ulcers in rodents, and vomiting and loose stools in dogs.

The major target organs in repeat-dose oral studies were lungs, and blood vessels with findings at administered dose levels and systemic exposures in animals that, in some instances, were without a defined margin compared with the human oral dose (0.5 mg/day) and associated systemic exposure.

Effects on the lymphoid system consisting of lymphopenia, lymphoid depletion (thymus cortex, spleen, lymph nodes), and increased size and density of staining of thymus medulla, were consistently observed across a wide range of doses in all animal species tested and essentially represent anticipated effects based on fingolimod pharmacology. Gastrointestinal protozoan infection was considered to reflect increased susceptibility to infection secondary to immunosuppression in monkeys administered 0.5 or 3 mg/kg. Granulomatous inflammation in lungs of mice and pneumonia observed in rats and dogs may also be secondary to immunosuppression.

Lung was a sensitive target organ in all animal species tested. Findings included increased lung weight and insufficient or lack of pulmonary collapse at necropsy. Microscopic lung changes included smooth muscle hypertrophy/hyperplasia and/or interstitial collagenization at the bronchoalveolar junction; hyperdistension of alveoli; and increased alveolar macrophage infiltrates. Lung pathologic changes occurred at ≥ 0.1 mg/kg in rats, ≥ 0.01 mg/kg in dogs, and ≥ 0.5 mg/kg in monkeys. In the 52-week monkey study respiratory distress was associated with ketamine administration at fingolimod doses of 3 and 10 mg/kg.

Vasculopathy in Wistar rats involved vessels in multiple organs including kidney, spleen, mesentery and brain. The lowest effect dose levels were 1.5 mg/kg in the 26-week study and 0.15 mg/kg in the 104-week carcinogenicity study. Vascular lesions in heart of dogs administered ≥ 1 mg/kg were considered related to hemodynamic effects of fingolimod.

Treatment-related kidney findings (nephropathy, tubular basophilia and/or hyaline casts) occurred in rodent studies (5 mg/kg in 13-week and ≥ 0.25 mg/kg in 104-week studies in mice; ≥ 0.3 mg/kg in 26-week and ≥ 0.05 mg/kg in 104-week studies in rats).

Pathologic changes were present in the nervous system in dogs at relatively high dose levels. Mononuclear cell infiltrates or perivascular mononuclear cells were present in brain or spinal cord at 10 mg/kg (26-week study) and 30 mg/kg (4-week study).

Treatment-related findings in repeat-dose toxicology studies generally showed evidence of potential reversibility following treatment withdrawal, although recovery was incomplete in some instances.

Effects on liver (increased transaminases in rats and dogs), pituitary (vacuolation and/or atrophy of anterior pituitary cells in rats and dogs), adrenal medulla (vacuolation and decrease in number of cells and fibrosis in dogs) and gastrointestinal tract (forestomach erosion in rats, stomach ulcers in dogs) mainly occurred at relatively high dose levels and inconsistently across species.

There were no treatment-related ophthalmoscopic findings in toxicology studies. Vasculopathy was present in eyes histopathologically for a small number of treated animals at ≥ 0.5 mg/kg in the 104-week rat study.

No evidence of carcinogenicity was observed in a 2-year bioassay in rats at oral doses of fingolimod up to the maximum tolerated dose of 2.5 mg/kg, representing an approximate 50-fold margin based on human systemic exposure (AUC) at the 0.5 mg dose. Vasculopathy and nephropathy were the main lesions contributing to the increased mortality at 0.5 and 2.5 mg/kg. In a 2-year mouse study, an increased incidence of malignant lymphoma was seen at doses of 0.25 mg/kg and higher, representing an approximate 6-fold margin based on human systemic exposure (AUC) at a daily dose of 0.5 mg.

Fingolimod was not mutagenic in an Ames test and in a L5178Y mouse lymphoma cell line in vitro. No clastogenic effects were seen in vitro in V79 Chinese hamster lung cells. Fingolimod induced numerical (polyploidy) chromosomal aberrations in V79 cells at concentrations of 3.7 $\mu\text{g/mL}$ and above. Fingolimod was not clastogenic in the in vivo micronucleus tests in mice and rats.

Fingolimod had no effect on sperm count or motility, nor on fertility in male and female rats up to the highest dose tested (10 mg/kg), representing an approximate 150-fold margin based on human systemic exposure (AUC) at a daily dose of 0.5 mg.

Fingolimod was teratogenic at doses of 0.1 mg/kg or higher (corresponding to 2 or more times the exposure in humans at the recommended dose of 0.5 mg) when given to pregnant rats during the period of organogenesis. The most common fetal visceral malformations included persistent truncus arteriosus and ventricular septum defect. The receptor affected by fingolimod (sphingosine -1-phosphate receptor) is known to be involved in vascular formation during embryogenesis. An increase in post-implantation loss was observed in rats at doses of 1 mg/kg and higher and a decrease in viable fetuses at 3 mg/kg. Fingolimod was not teratogenic in the rabbit, but an increased

incidence of embryo-fetal mortality was seen starting at doses of 1.5 mg/kg (corresponding to similar exposure in humans at the recommended dose of 0.5 mg), and a decrease in viable fetuses as well as fetal growth retardation at 5 mg/kg.

In rats, F1 generation pup survival was decreased in the early postpartum period at doses administered during pregnancy and lactation that did not cause maternal toxicity (0.05, 0.15 and 0.5 mg/kg). However, F1 body weights, development, behavior, and fertility were not affected by treatment with fingolimod.

Fingolimod was excreted in the milk of treated animals during lactation. Fingolimod and its metabolites crossed the placental barrier in pregnant rabbits.

Juvenile animal toxicity studies

Two toxicity studies in juvenile rats were performed. In the first study, with the focus on testing effects on immune function, fingolimod was given at daily doses of 0.5 or 5 mg/kg/day for nine weeks. There was a decreased immune response to repeated stimulations with Keyhole Limpet Hemocyanin (KLH), which was not considered adverse.

In a second study, with a focus on changes in behavior or reproductive function, fingolimod was given at daily doses of 0.3, 1.5 or 7.5 mg/kg for 7 weeks. There were slight effects on bone mineral density, neurobehavioral response, and delayed sexual maturation. Overall, the treatment-related effects of fingolimod in juvenile animals were comparable to those seen in adult rats at similar dose levels, with the exception of the absence of smooth muscle hypertrophy in the lungs of the juvenile rats. The no observed adverse effect levels (NOAELs) in juvenile animals were mainly driven by unspecific effects on body weight or food consumption rather than overt toxicity.

REFERENCES

1. Brinkmann V. FTY720 (fingolimod) in Multiple Sclerosis: therapeutic effects in the immune and the central nervous system. *Br J Pharmacol*, 2009 158(5):1173-82.
2. Chitnis T, Arnold D.L, Banwell B, et al. Trial of Fingolimod versus Interferon Beta-1a Pediatric Multiple Sclerosis. *N Engl J Med*, 2018 379(11):1017-27.
3. Choi JW, Gardell SE, Herr DR, et al. FTY720 (fingolimod) efficacy in an animal model of multiple sclerosis requires astrocyte sphingosine 1-phosphate receptor 1 (S1P1) modulation. *Proc Natl Acad Sci U S A*, 2011; 108(2):751-6.
4. Chun J, Hartung HP. Mechanism of Action of Oral Fingolimod (FTY720) in Multiple Sclerosis. *Clin Neuropharmacol*, 2010; 33(2):91-101.
5. Cohen JA, Barkhof F, Comi G, et al. Oral fingolimod or intramuscular interferon for relapsing multiple sclerosis. *N Engl J Med*, 2010; 362(5):402-15.
6. David OJ, Ocwieja M, Meiser K, et al. Pharmacokinetics of fingolimod (FTY720) and a combined oral contraceptive coadministered in healthy women: drug-drug interaction study results. *Int J Clin Pharmacol Ther*, 2012; 50(8):540-4.
7. Foster CA, Howard LM, Schweitzer A, et al. Brain penetration of the oral immunomodulatory drug FTY720 and its phosphorylation in the central nervous system during experimental autoimmune encephalomyelitis: consequences for mode of action in multiple sclerosis. *J Pharmacol Exp Ther*, 2007; 323(2):469-75.
8. Fujino M, Funeshima N, Kitazawa Y, et al. Amelioration of experimental autoimmune encephalomyelitis in Lewis rats by FTY720 treatment. *J Pharmacol Exp Ther*, 2003; 305:70-77.
9. Jaillard C, Harrison S, Stankoff B, et al. Edg8/S1P5: an oligodendroglial receptor with dual function on process retraction and cell survival. *J Neurosci*, 2005; 25(6):1459-1469.
10. Kappos L, Radue EW, O'Connor P, et al. A placebo-controlled trial of oral fingolimod in relapsing multiple sclerosis. *N Engl J Med*, 2010; 362(5):387-401.
11. Kimura A, Ohmori T, Ohkawa R, et al. Essential roles of sphingosine 1-phosphate/S1P1 receptor axis in the migration of neural stem cells toward a site of spinal cord injury. *Stem Cells*, 2007; 25(1):115-124.
12. Mandala S, Hajdu R, Bergstrom J, et al. Alteration of lymphocyte trafficking by sphingosine-1-phosphate receptor agonists. *Science*, 2002 296(5566):346-349.
13. Matloubian M, Lo CG, Cinamon G, et al. Lymphocyte egress from thymus and peripheral

- lymphoid organs is dependent on S1P receptor 1. *Nature*, 2004; 427(6972):355-360.
14. Miron VE, Schubart A, Antel JP. Central nervous system-directed effects of FTY720 (fingolimod). *J Neurol Sci*, 2008; 274(1-2):13-17.
 15. Miron VE, Jung CG, Kim HJ, et al. FTY720 modulates human oligodendrocyte progenitor process extension and survival. *Ann Neurol*, 2008; 63(1):61-71.
 16. Mizugishi K, Yamashita T, Olivera A, et al. Essential role for sphingosine kinases in neural and vascular development. *Mol Cell Biol*, 2005; 25(24):11113-11121.
 17. Pham TH, Okada T, Matloubian M, et al. S1P1 receptor signaling overrides retention mediated by G alpha i-coupled receptors to promote T-cell egress. *Immunity*, 2008; 28:122-33.
 18. Schwab SR, Cyster JG. Finding a way out: lymphocyte egress from lymphoid organs. *Nat Immunol*, 2007; 8(12):1295-301.

PART III: CONSUMER INFORMATION

PrGILENYA®
Fingolimod (as fingolimod hydrochloride)

This leaflet is part III of a three-part "Product Monograph" published when GILENYA® was approved for sale in Canada and is designed specifically for Consumers. This leaflet is a summary and will not tell you everything about GILENYA. Contact your doctor or pharmacist if you have any questions about the drug.

ABOUT THIS MEDICATION**What the medication is used for:**

GILENYA is used to treat:

- Adult patients with the relapsing and remitting form of multiple sclerosis (MS). GILENYA is generally recommended for MS patients who have not responded well to, or cannot tolerate one or more of the other therapies for multiple sclerosis.
- Children and adolescent patients (10 years to <18 years of age) with the relapsing form of MS.

What it does:

GILENYA does not cure MS, but it helps to reduce the number of attacks (relapses) that occur, reduce inflammation in the brain (brain lesions identified seen on MRI scans), and slow the build-up of physical problems due to MS (disability progression).

GILENYA changes how the body's immune system works by decreasing the ability of lymphocytes to move freely within the body. This lowers the number of lymphocytes in the blood and prevents them from reaching the brain and spinal cord. This may reduce the inflammation and nerve damage that happens in MS.

When it should not be used:

You should not take GILENYA if you

- are allergic (hypersensitive) to fingolimod or to any of the other ingredients listed in this leaflet.
- immune system is weakened (immunocompromised) due to disease (immunodeficiency syndrome) or medicines or treatments that suppress the immune system, such as medicines used to treat cancer or bone marrow transplantation.
- have a severe active infection or an active chronic infection such as hepatitis or tuberculosis.
- have an active cancer (except for a type of skin cancer called basal cell carcinoma).
- have severe liver disease.
- **have had a heart attack, angina, stroke or warning of a stroke or certain types of heart failure in the last 6 months.**
- **have certain types of irregular or abnormal heartbeat (arrhythmia), or your electrocardiogram (ECG) shows prolonged QT interval before starting GILENYA.**
- **are taking or have recently taken medicine for irregular heartbeat such as quinidine, disopyramide, amiodarone or sotalol (due to a possible added effect on irregular heartbeat).**

- are pregnant, suspect you may be pregnant or plan to get pregnant.
- are of childbearing age not using effective methods of birth control.
- are of childbearing age, until it is confirmed with a pregnancy test that you are not pregnant. This is done just before you begin treatment with GILENYA.

What the medicinal ingredient is:

The active substance of GILENYA is fingolimod.

What the nonmedicinal ingredients are:

GILENYA 0.5 mg hard capsules: gelatin, magnesium stearate, mannitol, titanium dioxide and yellow iron oxide.

GILENYA 0.25 mg hard capsules: mannitol, hydroxypropylcellulose, hydroxypropylbetadex, magnesium stearate, gelatin, titanium dioxide, iron oxide yellow.

What dosage forms it comes in:

Hard capsules: 0.25 mg & 0.5 mg fingolimod (as fingolimod hydrochloride)

The 0.25 mg capsules have an ivory opaque body and cap. The 0.5 mg capsules have a white opaque body and a bright yellow opaque cap.

WARNINGS AND PRECAUTIONS**Chickenpox vaccine**

Patients who have not had chickenpox or have not had the chickenpox vaccine are at risk of having a serious and life-threatening chickenpox infection during treatment with GILENYA. There have been very rare fatal cases of chickenpox infection reported in patients treated with GILENYA, who also received a relatively long course of corticosteroid therapy.

If you are not protected against chickenpox, your doctor may recommend that you receive the chickenpox vaccine 1 month before starting treatment with GILENYA.

BEFORE you use GILENYA talk to your doctor or pharmacist if:

- you have heart problems, such as **high blood pressure, or severe untreated sleep apnea.**
- **you are taking medicines for an irregular heartbeat** such as quinidine, disopyramide, amiodarone or sotalol. (see "When it should not be used")
- **you suffer from slow heart rate, you are already taking other medicines that slow your heart rate or you have a history of sudden loss of consciousness (fainting).**
- you have a weakened immune system (due to a disease or medicines that suppress the immune system).
- you have been vaccinated within 1 month before you start taking GILENYA or you plan to receive a vaccine. You should

not receive certain types of vaccines (called “live attenuated vaccines”) during and for up to 2 months after treatment with GILENYA.

- your child (10 years to <18 years of age) has not completed their vaccination schedule. They need to have completed this before starting treatment with GILENYA.
- you have never had chickenpox or have not been vaccinated for chickenpox.
- you have or have had visual disturbances or other signs of swelling in the central vision area at the back of the eye (a condition known as macular edema), inflammation or infection of the eye (uveitis).
- you have diabetes. Diabetes increases the risk of having macular edema during GILENYA treatment.
- you have liver problems. GILENYA may affect your liver function.
- you have low or high blood pressure. GILENYA causes a mild increase in blood pressure.
- you have high cholesterol or triglyceride levels. GILENYA may increase blood levels of cholesterol and triglycerides.
- you have kidney problems.
- you have breathing problems. GILENYA has a slight effect on lung function.
- you are pregnant, think you may be pregnant or are trying to become pregnant.
- you are breast feeding.

Your doctor will consider **whether you need to have a vaccination against Human Papilloma Virus (HPV)** before starting treatment. If you are a female, your doctor will also recommend HPV screening. HPV infection, including papilloma, dysplasia, warts and HPV-related cancer, has been reported in patients treated with GILENYA.

Monitoring: Before you start treatment and periodically during treatment, your doctor may want you to undergo several tests to help monitor side-effects of GILENYA. These will include: blood tests (to check your white blood cell counts, liver function), eye examination (to monitor for macular edema), checks of your heart rhythm and blood pressure, and possibly lung function.

Slow heart rate and irregular heart beat

GILENYA causes the heart rate to slow down, especially during the first month of treatment. GILENYA can also cause an irregular heartbeat, especially after the first dose (or when children/adolescents switch from the 0.25 mg capsule to the 0.5 mg capsule). Irregular heartbeat usually returns to normal in less than one day. Slow heart rate usually returns to normal within one month. These heart rhythm disturbances may be more likely in patients with risk factors, such as heart disease, or when certain interacting drugs are taken. In general, people more than 65 years of age are at higher risk.

If you have an irregular or abnormal heartbeat or a history of sudden loss of consciousness (fainting), your condition may worsen temporarily with GILENYA. The same applies if you have a slow heart rate or if you are taking medicines which slow the heartbeat.

If you experience any symptoms of a possible heart rhythm disturbance, such as dizziness, palpitations (sensation of rapid,

pounding, or irregular heart beat), fainting, or seizures, at any time during treatment with GILENYA, you should seek immediate medical attention.

Because fingolimod has side effects on the heart, you will be required to have an electrocardiogram (ECG) to check the health of your heart before you start fingolimod (or after taking the first dose of 0.5 mg when your child switches from the 0.25 mg capsule daily dose). Your doctor will ask you to stay in the clinic or office for at least 6 hours after taking the first dose of fingolimod so your heart rate and blood pressure can be checked each hour and appropriate measures can be taken if heart-related side effects occur at the start of treatment. A second ECG will be done 6 hours after taking the first dose. Depending on the results of the ECG, blood pressure checks and how you are feeling, you may need to be observed for longer, possibly overnight, in a health care facility. The same observation process may apply if you are starting treatment again after a break from fingolimod therapy.

Infections

The effects of GILENYA on your body’s immune system may reduce your body’s ability to fight infections and you may get infections more easily while you are taking GILENYA (and for up to 2 months after you stop taking it). If you have an infection, tell your doctor before you take GILENYA. Any infection that you already have may get worse. Infections could be serious and sometimes life-threatening. Before you start taking GILENYA, your doctor will confirm whether you have enough white blood cells in your blood. **During your treatment** with GILENYA, if you think you have an infection, have fever, feel like you have the flu, or have a headache with a stiff neck, sensitivity to light, nausea, and/or confusion (these may be caused by a serious fungal infection and may be symptoms of cryptococcal meningitis), contact your doctor right away. If you believe your MS is getting worse (e.g. weakness or visual changes) or if you notice any new or unusual symptoms, talk to your doctor as soon as possible, because these may be the symptoms of a rare brain disorder caused by infection and called progressive multifocal leukoencephalopathy (PML). Your doctor will consider performing an MRI scan to evaluate this condition and will decide whether you need to stop taking GILENYA.

The use of other medications and treatments that suppress or change how the immune system works is not recommended during treatment with GILENYA because the risk of infections can be increased further.

Macular edema

A problem with your vision, called macular edema, can occur during treatment with GILENYA. Macular edema can cause some of the same vision symptoms as an MS attack (optic neuritis), but you also may not notice any symptoms. Macular edema usually starts in the first 3 to 4 months after you start taking GILENYA. Your doctor should therefore test your vision 3 to 4 months after you start taking GILENYA, or any time you notice vision changes during treatment.

Your risk of macular edema may be higher if you have diabetes or have had an inflammation of your eye called uveitis. If you have or

have had visual disturbances or other signs of swelling in the central vision area (macula) at the back of the eye, uveitis or diabetes, your doctor should test your vision before you start taking GILENYA.

Seizures

Some patients have had seizures while taking GILENYA. It is not known whether the seizures were related to the effects of their MS, GILENYA, or to a combination of both. If you have a seizure while taking GILENYA, you should call your doctor right away.

Depression and Suicidal Ideation

Are known to occur in the MS population. Patients, families and caregivers of patients being treated with GILENYA should watch for these symptoms. Contact your health care professional **right away** if any of these symptoms occur.

Other warnings you should know about:

The effects of GILENYA on the body's immune system may increase the risk of developing lymphoma and other cancers such as skin cancer. Lymphoma and skin cancer, mostly basal cell carcinoma, have been reported in patients treated with GILENYA.

If you already have moles or open sores before starting treatment with GILENYA, pay attention for changes in the size, shape or color of moles or the healing of open sores (not healing within weeks) after you start treatment. These may be signs of skin cancer that you should talk to your doctor about.

A type of skin cancer called basal cell carcinoma (BCC) and other cutaneous neoplasms such as malignant melanoma, squamous cell carcinoma, Kaposi's sarcoma and Merkel cell carcinoma have ~~has~~ been reported in MS patients treated with GILENYA. During treatment with GILENYA you should check your skin regularly for unusual changes. Symptoms of BCC may include skin nodules (e.g. shiny pearly nodules), patches or open sores that do not heal within weeks. Symptoms of other skin cancers may include abnormal growth or changes of skin, such as unusual moles, that may change in color, shape or size over time. Your doctor will also do regular skin examinations during your treatment with GILENYA. Long-term exposure to the sun and a weak immune system can affect the risk of developing Merkel cell carcinoma. You should limit your exposure to the sun and UV rays by: wearing appropriate protective clothing and regularly applying sunscreen with a high degree of UV protection.

After GILENYA treatment is stopped, symptoms of MS can return and may become worse compared to before or during treatment. Tell your doctor if you have worsening of MS symptoms after stopping GILENYA.

A condition with unusually large brain lesions associated with MS relapse has been rarely reported in patients treated with GILENYA (a condition called tumefactive lesions). In case of severe relapse, your doctor will consider performing an MRI scan to evaluate this condition and will decide whether you need to stop taking GILENYA.

Older people (over 65 years old)

GILENYA was studied in very few MS patients over 65 years old. Treatment with GILENYA requires extra caution in older patients due to the greater likelihood of having other medical problems in

addition to MS.

Children and adolescents (under 10 years old)

GILENYA has not been studied in children under 10 years of age.

Pregnancy and breast-feeding

GILENYA can harm the unborn baby if used during pregnancy. If you are a female who could become pregnant or if you are a female planning to become pregnant, before you start treatment with GILENYA your doctor:

- will tell you about the risk to an unborn baby,
 - will ask you to do a pregnancy test in order to ensure that you are not pregnant,
- and
- you must use effective contraception while taking GILENYA and for two months after you stop taking it.

You must avoid becoming pregnant while taking GILENYA and in the two months after you stop taking it because of the risk of harming your unborn child. Talk with your doctor about the associated risk and about reliable methods of birth control that you must use during treatment and for 2 months after you stop treatment.

If you do become pregnant while taking GILENYA tell your doctor right away. You and your doctor will decide what is best for you and your baby. If you become pregnant while taking GILENYA, you can call the GILENYA Pregnancy Registry at 1-855-788-5333.

You should not breast-feed while you are taking GILENYA. GILENYA can pass into breast milk and there is a risk of serious side effects for a breast-fed baby.

Driving and using machines

After the first dose of GILENYA, you will need to stay at the doctor's office or clinic for at least 6 hours to have your heart rate checked. Your ability to drive and use machines may be affected during and potentially after this period.

INTERACTIONS WITH THIS MEDICATION

Tell your doctor if you are taking or have recently taken any of the following medicines:

- **Medicines for heart problems or high blood pressure.**
- **Medicines for an irregular heartbeat** such as, quinidine, disopyramide, amiodarone or sotalol. (see "When it should not be used")
- **Medicines that slow down heartbeat** such as atenolol or metoprolol (called beta-blockers), such as verapamil, or diltiazem (called calcium channel blockers) or digoxin.
- **Medicines that suppress or modulate the immune system including other medicines used to treat MS** (beta-interferon, glatiramer acetate, natalizumab, mitoxantrone, dimethyl fumarate, teriflunomide, alemtuzumab or corticosteroids) **or**

medicines used to treat cancer. GILENYA should not be started while you are on these medications. GILENYA can usually be started immediately after stopping beta interferon, glatiramer acetate or dimethyl fumarate provided that immune effects from these therapies have resolved. If switching to GILENYA from other disease modifying treatments for MS (listed above), your health care provider may want to wait for several months to reduce the possible added effect on the immune system and potential for increased risk of serious infections. However, starting treatment with GILENYA after alemtuzumab is not recommended.

When corticosteroids were used for a few days to treat relapses in the multiple sclerosis studies with GILENYA this did not result in increased infections. However, because there is the potential for increased risk of infection, extra caution is recommended if corticosteroids are used.

- **Vaccines.** If you need to receive a vaccine, seek your doctor's advice first. During and for up to 2 months after stopping treatment with GILENYA, administration of some vaccines containing live virus (live attenuated vaccines) may result in the infection that the vaccination should prevent, while other vaccines may not work well enough to protect you.
- **Antifungal drugs** (such as ketoconazole).
- **Antibiotics** (such as erythromycin).
- **Drugs to treat HIV infection.**
- **Asthma drugs.**

PROPER USE OF THIS MEDICATION

Always take GILENYA exactly as your doctor has told you.

Usual adult dose:

The dose is one capsule per day (0.5 mg of fingolimod) taken orally (by mouth).

Children and adolescents (10 years to < 18 years of age)

The dose depends on the body weight:

- Children and adolescents with a body weight equal to or below 40 kg: one 0.25 mg capsule per day.
- Children and adolescents with a body weight above 40 kg: one 0.5 mg capsule per day.

Children and adolescents who started on one 0.25 mg capsule per day and reach a stable body weight above 40 kg will be instructed by their doctor to switch to one 0.5 mg capsule per day. In this case, it is recommended to repeat the first dose observation period.

Take GILENYA once a day, at the same time each day with half a glass of water. GILENYA can be taken with or without food.

Do not stop taking GILENYA or change your dose without talking with your doctor.

GILENYA will stay in your body for up to 2 months after you stop taking it, the side effects described in this leaflet may still occur during that time.

Overdose:

If you have taken more GILENYA than your doctor has recommended contact the regional Poison Control Centre and a health care practitioner immediately, or go to the nearest hospital emergency department, even if there are no symptoms. Take the medication package with you when you go to the hospital.

Missed Dose:

If you forget a dose, take the next dose as planned. Do not take a double dose to make up for a forgotten dose.

If you missed a dose on one day during the first 2 weeks, or if you stop taking GILENYA for more than 7 days during weeks 3 and 4 of treatment, contact your doctor right away. Your doctor may decide to observe you at the time you take the next dose.

If you start GILENYA again after stopping for 2 weeks or more, you will start taking GILENYA again in your doctor's office or clinic. Do not restart GILENYA after stopping it for more than two weeks without seeking advice from your doctor.

SIDE EFFECTS AND WHAT TO DO ABOUT THEM

As with all medicines, patients treated with GILENYA may experience side effects, although not everybody gets them.

Very common side effects (affect more than 1 in 10 patients):

- Flu virus infection
- Headache
- Diarrhea
- Back pain
- Cough

Common side effects (affect between 1 and 10 in every 100 patients):

- Sinusitis
- Fungal infections affecting skin, nails or hair
- Dizziness
- Migraine
- Weakness
- Mild increase in blood pressure
- Skin rash
- Hair loss
- Itchy skin
- Weight loss
- Blurred vision
- Breathlessness
- Tingling or numbness
- Depression
- Eye pain

Uncommon side effects (affect between 1 and 10 in every 1,000 patients):

- Depressed mood.

Frequency not known:

- Nausea
- Muscle pain
- Joint pain

If any of these side effects affects you severely, tell your doctor.

If you notice any other side effects not mentioned in this leaflet, please inform your doctor or pharmacist.

SERIOUS SIDE EFFECTS, HOW OFTEN THEY HAPPEN AND WHAT TO DO ABOUT THEM				
Symptom / effect		Talk with your doctor or pharmacist		Stop taking drug and seek immediate emergency help
		Only if severe	In all cases	
Common	Symptoms of bronchitis such as cough with phlegm, chest pain, fever		✓	
	Symptoms of gastroenteritis such as vomiting, nausea, diarrhea, fever		✓	
	Symptoms of shingles (or herpes zoster) such as blisters, burning, itching or pain of the skin, typically on the upper body or the face. Other symptoms may be fever followed by numbness, itching or red patches with severe pain		✓	
	Symptoms of slow heartbeat (bradycardia) such as feeling dizzy, tired, awareness of own heartbeat, decrease in blood pressure		✓	
	Symptoms of a type of skin		✓	

SERIOUS SIDE EFFECTS, HOW OFTEN THEY HAPPEN AND WHAT TO DO ABOUT THEM				
Symptom / effect		Talk with your doctor or pharmacist		Stop taking drug and seek immediate emergency help
		Only if severe	In all cases	
	cancer called basal cell carcinoma (BCC), which often appears as a pearly nodule, though it can also take other forms			
	Symptoms of low level of white blood cells such as fever, sore throat or mouth ulcers due to infections		✓	
Uncommon	Symptoms of pneumonia such as fever, cough, difficulty breathing		✓	
	Symptoms of macular edema (swelling in the central vision area of the retina at the back of the eye) such as shadows or blind spot in the center of the vision, blurred vision, problems seeing colors or fine details		✓	
	Liver disorder (symptoms include feeling nauseous or throwing up, loss of appetite, swelling and/or pain in the abdomen, feeling tired, itching, yellowing of the skin or eyes, dark urine)		✓	
	Trouble breathing		✓	
	Melanoma, a type of skin cancer that usually develops from an unusual mole. New moles or moles that may		✓	

SERIOUS SIDE EFFECTS, HOW OFTEN THEY HAPPEN AND WHAT TO DO ABOUT THEM

Symptom / effect	Talk with your doctor or pharmacist		Stop taking drug and seek immediate emergency help
	Only if severe	In all cases	
change in size, shape, height or colour over time as well, may be signs of melanoma. The moles may itch, bleed or form a sore.			
Convulsions, fits (more frequent in children and adolescents than in adults)			✓
Rare Stroke (symptoms include weakness and/or loss of feeling of limbs or face, difficulty speaking, clumsiness, vision loss)			✓
Peripheral artery disease (symptoms include cold, painful, discolored limb, fingers or toes)			✓
Posterior reversible encephalopathy syndrome (PRES) (symptoms may include sudden severe headache, feeling nauseous or throwing up confusion, drowsiness, personality change, paralysis, abnormal speech, convulsions and vision changes)			✓
Cancer of the lymphatic system (lymphoma) (symptoms may include painless swelling of lymph node, swollen tonsils, fever, chills, night		✓	

SERIOUS SIDE EFFECTS, HOW OFTEN THEY HAPPEN AND WHAT TO DO ABOUT THEM

Symptom / effect	Talk with your doctor or pharmacist		Stop taking drug and seek immediate emergency help
	Only if severe	In all cases	
sweats, feeling tired, itching, unexplained weight loss, loss of appetite, persistent coughing/ difficulty breathing or not being able to breathe, and headache)			
Very Rare Tumour related to infection with human herpes virus 8 called Kaposi's sarcoma (symptoms may include purple, red or brown blotches or tumours, usually on the skin of the legs or face)		✓	
Isolated cases Temporary but serious abnormal heart beat			✓
Frequency not known Cryptococcal infections (a type of fungal infection), including meningitis with symptoms such as headache with a stiff neck, sensitivity to light, feeling nauseous and/or confusion		✓	
Progressive multifocal leukoencephalopathy (PML), a rare brain infection (symptoms may include weakness on one side of your body, problems thinking, or vision changes)		✓	
Return of disease activity		✓	

SERIOUS SIDE EFFECTS, HOW OFTEN THEY HAPPEN AND WHAT TO DO ABOUT THEM

Symptom / effect	Talk with your doctor or pharmacist		Stop taking drug and seek immediate emergency help
	Only if severe	In all cases	
after stopping treatment (worsening of symptoms of MS compared to before and during treatment)			
Human Papilloma Virus (HPV) infection, including papilloma, dysplasia, warts and HPV-related cancer		✓	
Allergic reactions, including symptoms of rash or itchy hives, swelling of lips, tongue or face, which are more likely to occur on the day you start GILENYA treatment.		✓	

This is not a complete list of side effects. For any unexpected effects while taking GILENYA, contact your doctor or pharmacist.

HOW TO STORE IT

- Do not use GILENYA after the expiry date shown on the box.
- Store at 15-25°C.
- Store in the original package, protect from moisture.
- Keep out of the reach and sight of children.

Reporting Side Effects

You can report any suspected side effects associated with the use of health products to Health Canada by:

- Visiting the Web page on Adverse Reaction Reporting (<http://www.hc-sc.gc.ca/dhp-mps/medeff/report->

declaration/index-eng.php) for information on how to report online, by mail or by fax; or

- Calling toll-free at 1-866-234-2345.

NOTE: Contact your health professional if you need information about how to manage your side effects. The Canada Vigilance Program does not provide medical advice.

MORE INFORMATION

Please consult your doctor or pharmacist with any questions or concerns you may have regarding your individual condition.

This document plus the full product monograph, prepared for health professionals can be found at:

www.novartis.ca

or by contacting the sponsor, Novartis Pharmaceuticals Canada Inc., at:

1-800-363-8883

If you become pregnant while taking GILENYA, talk to your doctor about registering with the GILENYA Pregnancy Registry. You can enroll in this registry by calling:

1-855-788-5333.

This leaflet was prepared by:
 Novartis Pharmaceuticals Canada Inc.
 385 Bouchard Blvd.
 Dorval, Quebec
 H9S 1A9.

Last revised: December 19, 2019

GILENYA is a registered trademark

HIGHLIGHTS OF PRESCRIBING INFORMATION

These highlights do not include all the information needed to use GILENYA® safely and effectively. See full prescribing information for GILENYA.

GILENYA (fingolimod) capsules, for oral use

Initial U.S. Approval: 2010

RECENT MAJOR CHANGES

Indications and Usage (1)	8/2019
Dosage and Administration (2.1)	8/2019
Contraindications (4)	1/2019
Warnings and Precautions (5.5)	8/2019
Warnings and Precautions (5.2, 5.8, 5.10, 5.12)	12/2019

INDICATIONS AND USAGE

GILENYA is a sphingosine 1-phosphate receptor modulator indicated for the treatment of relapsing forms of multiple sclerosis (MS), to include clinically isolated syndrome, relapsing-remitting disease, and active secondary progressive disease, in patients 10 years of age and older. (1)

DOSAGE AND ADMINISTRATION

- Assessments are required prior to initiating GILENYA (2.1)
- Recommended dosage for adults and pediatric patients (10 years of age and older) weighing more than 40 kg: 0.5 mg orally once-daily, with or without food (2.2, 2.3)
- Recommended dosage for pediatric patients (10 years of age and above) weighing less than or equal to 40 kg: 0.25 mg orally once-daily, with or without food (2.2, 2.3).
- First-Dose Monitoring (including reinitiation after discontinuation greater than 14 days and dose increases):
 - Observe all patients for bradycardia for at least 6 hours; monitor pulse and blood pressure hourly. Electrocardiograms (ECGs) prior to dosing and at end of observation period required. (2.4)
 - Monitor until resolution if heart rate < 45 beats per minute (bpm) in adults, < 55 bpm in patients aged 12 years and above, or < 60 bpm in pediatric patients aged 10 to below 12 years, atrioventricular (AV) block, or if lowest postdose heart rate is at the end of the observation period. (2.4)
 - Monitor symptomatic bradycardia with ECG until resolved. Continue overnight if intervention is required; repeat first-dose monitoring for second dose. (2.4)
 - Observe patients overnight if at higher risk of symptomatic bradycardia, heart block, prolonged QTc interval, or if taking drugs with known risk of torsades de pointes. (2.4, 7.1)

DOSAGE FORMS AND STRENGTHS

0.25 mg hard capsules (3)
0.5 mg hard capsules (3)

CONTRAINDICATIONS

- Recent myocardial infarction, unstable angina, stroke, transient ischemic attack, decompensated heart failure with hospitalization, or Class III/IV heart failure. (4)
- History of Mobitz Type II 2nd degree or 3rd degree AV block or sick sinus syndrome, unless patient has a pacemaker. (4)

- Baseline QTc interval \geq 500 msec. (4)
- Cardiac arrhythmias requiring anti-arrhythmic treatment with Class Ia or Class III anti-arrhythmic drugs. (4)
- Hypersensitivity to fingolimod or its excipients. (4)

WARNINGS AND PRECAUTIONS

- **Infections:** GILENYA may increase the risk. Obtain a complete blood count (CBC) before initiating treatment. Monitor for infection during treatment and for 2 months after discontinuation. Do not start in patients with active infections. (5.2)
- **Progressive Multifocal Leukoencephalopathy (PML):** Withhold GILENYA at the first sign or symptom suggestive of PML. (5.3)
- **Macular Edema:** Examine the fundus before and 3-4 months after treatment start. Diabetes mellitus and uveitis increase the risk. (5.4)
- **Liver Injury:** Obtain liver enzyme results before initiation and periodically during treatment. Closely monitor patients with severe hepatic impairment. Discontinue if there is evidence of liver injury without other cause. (5.5, 8.6, 12.3)
- **Posterior Reversible Encephalopathy Syndrome (PRES):** If suspected, discontinue GILENYA. (5.6)
- **Respiratory Effects:** Evaluate when clinically indicated. (5.7)
- **Fetal Risk:** May cause fetal harm. Advise females of reproductive potential of the potential risk to a fetus and to use an effective method of contraception during treatment and for 2 months after stopping GILENYA. (5.8, 8.1, 8.3)
- **Severe Increase in Disability After Stopping GILENYA:** Monitor for development of severe increase in disability following discontinuation and begin appropriate treatment as needed. (5.9)
- **Tumefactive MS:** Consider when severe MS relapse occurs during treatment or after discontinuation. Obtain imaging and begin treatment as needed.
- **Increased Blood Pressure (BP):** Monitor BP during treatment. (5.11)
- **Malignancies:** Suspicious skin lesions should be evaluated. (5.12)

ADVERSE REACTIONS

Most common adverse reactions (incidence \geq 10% and greater than placebo): Headache, liver transaminase elevation, diarrhea, cough, influenza, sinusitis, back pain, abdominal pain, and pain in extremity. (6.1)

To report SUSPECTED ADVERSE REACTIONS, contact Novartis Pharmaceuticals Corporation at 1-888-669-6682 or FDA at 1-800-FDA-1088 or www.fda.gov/medwatch.

DRUG INTERACTIONS

- **Systemic Ketoconazole:** Monitor during concomitant use. (7.2, 12.3)
- **Vaccines:** Avoid live attenuated vaccines during, and for 2 months after stopping GILENYA treatment. (5.2, 7.3)

See 17 for PATIENT COUNSELING INFORMATION and Medication Guide.

Revised: 12/2019

FULL PRESCRIBING INFORMATION: CONTENTS*

1 INDICATIONS AND USAGE

2 DOSAGE AND ADMINISTRATION

- 2.1 Assessment Prior to Initiating GILENYA
- 2.2 Important Administration Instructions
- 2.3 Recommended Dosage
- 2.4 First-Dose Monitoring
- 2.5 Monitoring After Reinitiation of Therapy Following Discontinuation

3 DOSAGE FORMS AND STRENGTHS

4 CONTRAINDICATIONS

5 WARNINGS AND PRECAUTIONS

- 5.1 Bradyarrhythmia and Atrioventricular Blocks
- 5.2 Infections
- 5.3 Progressive Multifocal Leukoencephalopathy
- 5.4 Macular Edema
- 5.5 Liver Injury
- 5.6 Posterior Reversible Encephalopathy Syndrome
- 5.7 Respiratory Effects
- 5.8 Fetal Risk
- 5.9 Severe Increase in Disability After Stopping GILENYA
- 5.10 Tumefactive Multiple Sclerosis
- 5.11 Increased Blood Pressure
- 5.12 Malignancies
- 5.13 Immune System Effects Following GILENYA Discontinuation
- 5.14 Hypersensitivity Reactions

6 ADVERSE REACTIONS

- 6.1 Clinical Trials Experience
- 6.2 Postmarketing Experience

7 DRUG INTERACTIONS

- 7.1 QT Prolonging Drugs
- 7.2 Ketoconazole

- 7.3 Vaccines

- 7.4 Antineoplastic, Immunosuppressive, or Immune-Modulating Therapies

- 7.5 Drugs That Slow Heart Rate or Atrioventricular Conduction (e.g., beta blockers or diltiazem)

- 7.6 Laboratory Test Interaction

8 USE IN SPECIFIC POPULATIONS

- 8.1 Pregnancy

- 8.2 Lactation

- 8.3 Females and Males of Reproductive Potential

- 8.4 Pediatric Use

- 8.5 Geriatric Use

- 8.6 Hepatic Impairment

- 8.7 Renal Impairment

10 OVERDOSAGE

11 DESCRIPTION

12 CLINICAL PHARMACOLOGY

- 12.1 Mechanism of Action

- 12.2 Pharmacodynamics

- 12.3 Pharmacokinetics

13 NONCLINICAL TOXICOLOGY

- 13.1 Carcinogenesis, Mutagenesis, Impairment of Fertility

- 13.2 Animal Toxicology and/or Pharmacology

14 CLINICAL STUDIES

- 14.1 Adults

- 14.2 Pediatric Patients (10 to less than 18 Years of Age)

16 HOW SUPPLIED/STORAGE AND HANDLING

- 16.1 How Supplied

- 16.2 Storage and Handling

17 PATIENT COUNSELING INFORMATION

* Sections or subsections omitted from the full prescribing information are not listed.

FULL PRESCRIBING INFORMATION

1 INDICATIONS AND USAGE

GILENYA is indicated for the treatment of relapsing forms of multiple sclerosis (MS), to include clinically isolated syndrome, relapsing-remitting disease, and active secondary progressive disease, in patients 10 years of age and older.

2 DOSAGE AND ADMINISTRATION

2.1 Assessment Prior to Initiating GILENYA

Cardiac Evaluation

Obtain a cardiac evaluation in patients with certain preexisting conditions [see *Warnings and Precautions (5.1)*].

Prior to starting treatment, determine whether patients are taking drugs that could slow heart rate or atrioventricular (AV) conduction [see *Dosage and Administration (2.4)*, *Drug Interactions (7.5)*].

Complete Blood Count (CBC)

Review results of a recent CBC [see *Warnings and Precautions (5.2)*, *Drug Interactions (7.6)*].

Serum transaminases (ALT and AST) and Total Bilirubin Levels

Prior to starting treatment with GILENYA (i.e., within 6 months), obtain serum transaminases (ALT and AST) and total bilirubin levels [see *Warnings and Precautions (5.5)*].

Prior Medications

If patients are taking antineoplastic, immunosuppressive, or immune-modulating therapies, or if there is a history of prior use of these drugs, consider possible unintended additive immunosuppressive effects before initiating treatment with GILENYA [see *Warnings and Precautions (5.2)*, *Drug Interactions (7.4)*].

Vaccinations

Test patients for antibodies to varicella zoster virus (VZV) before initiating GILENYA; VZV vaccination of antibody-negative patients is recommended prior to commencing treatment with GILENYA [see *Warnings and Precautions (5.2)*]. It is recommended that pediatric patients if possible, complete all immunizations in accordance with current immunization guidelines prior to initiating GILENYA therapy.

2.2 Important Administration Instructions

Patients who initiate GILENYA, and those who reinstate treatment after discontinuation for longer than 14 days, require first-dose monitoring. This monitoring is also recommended when the dose is increased in pediatric patients [see *Dosage and Administration (2.4, 2.5)*].

GILENYA can be taken with or without food.

2.3 Recommended Dosage

In adults and pediatric patients 10 years of age and older weighing more than 40 kg, the recommended dosage of GILENYA is 0.5 mg orally once-daily.

In pediatric patients 10 years of age and older weighing less than or equal to 40 kg, the recommended dosage of GILENYA is 0.25 mg orally once daily.

Fingolimod doses higher than 0.5 mg are associated with a greater incidence of adverse reactions without additional benefit.

2.4 First-Dose Monitoring

Initiation of GILENYA treatment results in a decrease in heart rate, for which monitoring is recommended [see *Warnings and Precautions (5.1)*, *Clinical Pharmacology (12.2)*]. Prior to dosing and at the end of the observation period, obtain an electrocardiogram (ECG) in all patients.

First 6-Hour Monitoring

Administer the first dose of GILENYA in a setting in which resources to appropriately manage symptomatic bradycardia are available. Monitor all patients for 6 hours after the first dose for signs and symptoms of bradycardia with hourly pulse and blood pressure measurement.

Additional Monitoring after 6-Hour Monitoring

Continue monitoring until the abnormality resolves if any of the following is present (even in the absence of symptoms) after 6 hours:

- The heart rate 6 hours postdose is less than 45 bpm in adults, less than 55 bpm in pediatric patients 12 years of age and older, or less than 60 bpm in pediatric patients 10 or 11 years of age
- The heart rate 6 hours postdose is at the lowest value postdose suggesting that the maximum pharmacodynamic effect on the heart may not have occurred
- The ECG 6 hours postdose shows new onset second degree or higher AV block.

If postdose symptomatic bradycardia occurs, initiate appropriate management, begin continuous ECG monitoring, and continue monitoring until the symptoms have resolved if no pharmacological treatment is required. If pharmacological treatment is required, continue monitoring overnight and repeat 6-hour monitoring after the second dose.

Overnight Monitoring

Continuous overnight ECG monitoring in a medical facility should be instituted:

- in patients that require pharmacologic intervention for symptomatic bradycardia. In these patients, the first-dose monitoring strategy should be repeated after the second dose of GILENYA
- in patients with some preexisting heart and cerebrovascular conditions [see *Warnings and Precautions (5.1)*]
- in patients with a prolonged QTc interval before dosing or during 6-hour observation, or at additional risk for QT prolongation, or on concurrent therapy with QT prolonging drugs with a known risk of torsades de pointes [see *Warnings and Precautions (5.1), Drug Interactions (7.1)*]
- in patients receiving concurrent therapy with drugs that slow heart rate or AV conduction [see *Drug Interactions (7.5)*].

2.5 Monitoring After Reinitiation of Therapy Following Discontinuation

When restarting GILENYA after discontinuation for more than 14 days after the first month of treatment, perform first-dose monitoring, because effects on heart rate and AV conduction may recur on reintroduction of GILENYA treatment [see *Dosage and Administration (2.4)*]. The same precautions (first-dose monitoring) as for initial dosing are applicable. Within the first 2 weeks of treatment, first-dose procedures are recommended after interruption of 1 day or more; during Weeks 3 and 4 of treatment, first-dose procedures are recommended after treatment interruption of more than 7 days.

3 DOSAGE FORMS AND STRENGTHS

GILENYA is available as:

- 0.25 mg hard capsules with an ivory opaque body and cap, with black radial imprint “FTY 0.25mg” on the cap and a black radial band on the capsule body.
- 0.5 mg hard capsules with a white opaque body and bright yellow cap imprinted with “FTY 0.5 mg” on the cap and 2 radial bands imprinted on the capsule body with yellow ink.

4 CONTRAINDICATIONS

GILENYA is contraindicated in patients who have:

- in the last 6 months experienced myocardial infarction, unstable angina, stroke, TIA, decompensated heart failure requiring hospitalization or Class III/IV heart failure
- a history or presence of Mobitz Type II second-degree or third-degree AV block or sick sinus syndrome, unless patient has a functioning pacemaker [see *Warnings and Precautions (5.1)*]
- a baseline QTc interval ≥ 500 msec

- cardiac arrhythmias requiring anti-arrhythmic treatment with Class Ia or Class III anti-arrhythmic drugs
- had a hypersensitivity reaction to fingolimod or any of the excipients in GILENYA. Observed reactions include rash, urticaria and angioedema upon treatment initiation [see *Warnings and Precautions (5.14)*].

5 WARNINGS AND PRECAUTIONS

5.1 Bradyarrhythmia and Atrioventricular Blocks

Because of a risk for bradyarrhythmia and AV blocks, patients should be monitored during GILENYA treatment initiation [see *Dosage and Administration (2.4)*].

Reduction in Heart Rate

After the first dose of GILENYA, the heart rate decrease starts within an hour. On Day 1, the maximum decline in heart rate generally occurs within 6 hours and recovers, although not to baseline levels, by 8 to 10 hours postdose. Because of physiological diurnal variation, there is a second period of heart rate decrease within 24 hours after the first dose. In some patients, heart rate decrease during the second period is more pronounced than the decrease observed in the first 6 hours. Heart rates below 40 beats per minute (bpm) in adults, and below 50 bpm in pediatric patients occurred rarely. In controlled clinical trials in adult patients, adverse reactions of symptomatic bradycardia following the first dose were reported in 0.6% of patients receiving GILENYA 0.5 mg and in 0.1% of patients on placebo. Patients who experienced bradycardia were generally asymptomatic, but some patients experienced hypotension, dizziness, fatigue, palpitations, and/or chest pain that usually resolved within the first 24 hours on treatment.

Patients with some preexisting conditions (e.g., ischemic heart disease, history of myocardial infarction, congestive heart failure, history of cardiac arrest, cerebrovascular disease, uncontrolled hypertension, history of symptomatic bradycardia, history of recurrent syncope, severe untreated sleep apnea, AV block, sinoatrial heart block) may poorly tolerate the GILENYA-induced bradycardia, or experience serious rhythm disturbances after the first dose of GILENYA. Prior to treatment with GILENYA, these patients should have a cardiac evaluation by a physician appropriately trained to conduct such evaluation, and if treated with GILENYA, should be monitored overnight with continuous ECG in a medical facility after the first dose.

Since initiation of GILENYA treatment, results in decreased heart rate and may prolong the QT interval, patients with a prolonged QTc interval (> 450 msec adult and pediatric males, > 470 msec adult females, or > 460 msec pediatric females) before dosing or during 6-hour observation, or at additional risk for QT prolongation (e.g., hypokalemia, hypomagnesemia, congenital long-QT syndrome), or on concurrent therapy with QT prolonging drugs with a known risk of torsades de pointes (e.g., citalopram, chlorpromazine, haloperidol, methadone, erythromycin) should be monitored overnight with continuous ECG in a medical facility

Following the second dose, a further decrease in heart rate may occur when compared to the heart rate prior to the second dose, but this change is of a smaller magnitude than that observed following the first dose. With continued dosing, the heart rate returns to baseline within 1 month of chronic treatment. Clinical data indicate effects of GILENYA on heart rate are maximal after the first dose although milder effects on heart rate may persist for, on average, 2 to 4 weeks after initiation of therapy at which time heart rate generally returns to baseline. Physicians should continue to be alert to patient reports of cardiac symptoms.

Atrioventricular Blocks

Initiation of GILENYA treatment has resulted in transient AV conduction delays. In controlled clinical trials in adult patients, first-degree AV block after the first dose occurred in 4.7% of patients receiving GILENYA and 1.6% of patients on placebo. In a study of 697 patients with available 24-hour Holter monitoring data after their first dose (N = 351 receiving GILENYA and N = 346 on placebo), second-degree AV blocks (Mobitz Types I [Wenckebach] or 2:1 AV blocks) occurred in 4% (N = 14) of patients receiving GILENYA and 2% (N = 7) of patients on placebo. Of the 14 patients receiving GILENYA, 7 patients had 2:1 AV block (5 patients within the first 6 hours postdose and 2 patients after 6 hours postdose). All second degree AV blocks on placebo were Mobitz Type I and occurred after the first 12 hours postdose. The conduction abnormalities were usually transient and asymptomatic, and resolved within the first 24 hours on treatment, but they occasionally required treatment with atropine or isoproterenol.

Postmarketing Experience

In the postmarketing setting, third-degree AV block and AV block with junctional escape have been observed during the first-dose 6-hour observation period with GILENYA. Isolated delayed onset events, including transient asystole and unexplained death, have occurred within 24 hours of the first dose. These events were confounded by concomitant medications and/or preexisting disease, and the relationship to GILENYA is uncertain. Cases of syncope were also reported after the first dose of GILENYA.

5.2 Infections

Risk of Infections

GILENYA causes a dose-dependent reduction in peripheral lymphocyte count to 20%-30% of baseline values because of reversible sequestration of lymphocytes in lymphoid tissues. GILENYA may therefore increase the risk of infections, some serious in nature [see *Clinical Pharmacology (12.2)*]. Life-threatening and fatal infections have occurred in association with GILENYA.

Before initiating treatment with GILENYA, a recent CBC (i.e., within 6 months or after discontinuation of prior therapy) should be available. Consider suspending treatment with GILENYA if a patient develops a serious infection, and reassess the benefits and risks prior to reinitiation of therapy. Because the elimination of fingolimod after discontinuation may take up to 2 months, continue monitoring for infections throughout this period. Instruct patients receiving GILENYA to report symptoms of infections to a physician. Patients with active acute or chronic infections should not start treatment until the infection(s) is resolved.

In MS placebo-controlled trials in adult patients, the overall rate of infections (72%) with GILENYA was similar to placebo. However, bronchitis, herpes zoster, influenza, sinusitis, and pneumonia were more common in GILENYA-treated patients. Serious infections occurred at a rate of 2.3% in the GILENYA group versus 1.6% in the placebo group.

In the postmarketing setting, serious infections with opportunistic pathogens including viruses (e.g., John Cunningham virus (JCV), herpes simplex viruses 1 and 2, varicella zoster virus), fungi (e.g., cryptococci), and bacteria (e.g., atypical mycobacteria) have been reported with GILENYA. Patients with symptoms and signs consistent with any of these infections should undergo prompt diagnostic evaluation and appropriate treatment.

Herpes Viral Infections

In placebo-controlled trials in adult patients, the rate of herpetic infections was 9% in patients receiving GILENYA 0.5 mg and 7% on placebo.

Two patients died of herpetic infections during controlled trials. One death was due to disseminated primary herpes zoster and the other was to herpes simplex encephalitis. In both cases, the patients were taking a 1.25 mg dose of fingolimod (higher than the recommended 0.5 mg dose) and had received high-dose corticosteroid therapy to treat suspected MS relapses.

Serious, life-threatening events of disseminated varicella zoster and herpes simplex infections, including cases of encephalitis and multiorgan failure, have occurred with GILENYA in the postmarketing setting. Include disseminated herpetic infections in the differential diagnosis of patients who are receiving GILENYA and present with an atypical MS relapse or multiorgan failure.

Cases of Kaposi's sarcoma have been reported in the postmarketing setting. Kaposi's sarcoma is an angioproliferative disorder that is associated with infection with human herpes virus 8 (HHV-8). Patients with symptoms or signs consistent with Kaposi's sarcoma should be referred for prompt diagnostic evaluation and management.

Cryptococcal Infections

Cryptococcal infections, including cases of fatal cryptococcal meningitis and disseminated cryptococcal infections, have been reported with GILENYA in the postmarketing setting. Cryptococcal infections have generally occurred after approximately 2 years of GILENYA treatment, but may occur earlier. The relationship between the risk of cryptococcal infection and the duration of treatment is unknown. Patients with symptoms and signs consistent with a cryptococcal infection should undergo prompt diagnostic evaluation and treatment.

Prior and Concomitant Treatment with Antineoplastic, Immunosuppressive, or Immune-Modulating Therapies

In clinical studies, patients who received GILENYA did not receive concomitant treatment with antineoplastic, non-corticosteroid immunosuppressive, or immune-modulating therapies used for treatment of MS. Concomitant use of GILENYA with any of these therapies, and also with corticosteroids, would be expected to increase the risk of immunosuppression [see *Drug Interactions (7.4)*].

When switching to GILENYA from immune-modulating or immunosuppressive medications, consider the duration of their effects and their mode of action to avoid unintended additive immunosuppressive effects.

Varicella Zoster Virus Antibody Testing/Vaccination

Patients without a healthcare professional confirmed history of chickenpox or without documentation of a full course of vaccination against VZV should be tested for antibodies to VZV before initiating GILENYA. VZV vaccination of antibody-negative patients is recommended prior to commencing treatment with GILENYA, following which initiation of treatment with GILENYA should be postponed for 1 month to allow the full effect of vaccination to occur [see *Drug Interactions (7.3)*, *Use in Specific Populations (8.4)*].

Human Papilloma Virus (HPV) Infection

Human papilloma virus (HPV) infections, including papilloma, dysplasia, warts, and HPV-related cancer, have been reported in patients treated with GILENYA in the postmarketing setting. Vaccination against HPV should be considered prior to treatment initiation with GILENYA, taking into account vaccination recommendations. Cancer screening, including Papanicolaou (Pap) test, is recommended as per standard of care for patients using an immunosuppressive therapy.

5.3 Progressive Multifocal Leukoencephalopathy

Cases of progressive multifocal leukoencephalopathy (PML) have occurred in patients with MS who received GILENYA in the postmarketing setting. PML is an opportunistic viral infection of the brain caused by the JC virus (JCV) that typically only occurs in patients who are immunocompromised, and that usually leads to death or severe disability. PML has occurred in patients who had not been treated previously with natalizumab, which has a known association with PML, were not taking any other immunosuppressive or immunomodulatory medications concomitantly, and did not have any ongoing systemic medical conditions resulting in compromised immune system function. The majority of cases have occurred in patients treated with GILENYA for at least 2 years. The relationship between the risk of PML and the duration of treatment is unknown.

At the first sign or symptom suggestive of PML, withhold GILENYA and perform an appropriate diagnostic evaluation. Typical symptoms associated with PML are diverse, progress over days to weeks, and include progressive weakness on one side of the body or clumsiness of limbs, disturbance of vision, and changes in thinking, memory, and orientation leading to confusion and personality changes.

MRI findings may be apparent before clinical signs or symptoms. Cases of PML, diagnosed based on MRI findings and the detection of JCV DNA in the cerebrospinal fluid in the absence of clinical signs or symptoms specific to PML, have been reported in patients treated with MS medications associated with PML, including GILENYA. Many of these patients subsequently became symptomatic with PML. Therefore, monitoring with MRI for signs that may be consistent with PML may be useful, and any suspicious findings should lead to further investigation to allow for an early diagnosis of PML, if present. Lower PML-related mortality and morbidity have been reported following discontinuation of another MS medication associated with PML in patients with PML who were initially asymptomatic compared to patients with PML who had characteristic clinical signs and symptoms at diagnosis. It is not known whether these differences are due to early detection and discontinuation of MS treatment or due to differences in disease in these patients.

5.4 Macular Edema

Fingolimod increases the risk of macular edema. Perform an examination of the fundus including the macula in all patients before starting treatment, again 3 to 4 months after starting treatment, and again at any time after a patient reports visual disturbances while on GILENYA therapy.

A dose-dependent increase in the risk of macular edema occurred in the GILENYA clinical development program.

In 2-year double-blind, placebo-controlled studies in adult patients with multiple sclerosis, macular edema with or without visual symptoms occurred in 1.5% of patients (11/799) treated with fingolimod 1.25 mg, 0.5% of patients

(4/783) treated with GILENYA 0.5 mg, and 0.4% of patients (3/773) treated with placebo. Macular edema occurred predominantly during the first 3 to 4 months of therapy. These clinical trials excluded patients with diabetes mellitus, a known risk factor for macular edema (see below *Macular Edema in Patients with History of Uveitis or Diabetes Mellitus*). Symptoms of macular edema included blurred vision and decreased visual acuity. Routine ophthalmological examination detected macular edema in some patients with no visual symptoms. Macular edema generally partially or completely resolved with or without treatment after drug discontinuation. Some patients had residual visual acuity loss even after resolution of macular edema. Macular edema has also been reported in patients taking GILENYA in the postmarketing setting, usually within the first 6 months of treatment.

Continuation of GILENYA in patients who develop macular edema has not been evaluated. A decision on whether or not to discontinue GILENYA therapy should include an assessment of the potential benefits and risks for the individual patient. The risk of recurrence after rechallenge has not been evaluated.

Macular Edema in Patients with History of Uveitis or Diabetes Mellitus

Patients with a history of uveitis and patients with diabetes mellitus are at increased risk of macular edema during GILENYA therapy. The incidence of macular edema is also increased in MS patients with a history of uveitis. In the combined clinical trial experience in adult patients with all doses of fingolimod, the rate of macular edema was approximately 20% in MS patients with a history of uveitis versus 0.6% in those without a history of uveitis. GILENYA has not been tested in MS patients with diabetes mellitus. In addition to the examination of the fundus including the macula prior to treatment and at 3 to 4 months after starting treatment, MS patients with diabetes mellitus or a history of uveitis should have regular follow-up examinations.

5.5 Liver Injury

Clinically significant liver injury has occurred in patients treated with Gilenya in the postmarketing setting. Signs of liver injury, including markedly elevated serum hepatic enzymes and elevated total bilirubin, have occurred as early as ten days after the first dose and have also been reported after prolonged use. Cases of acute liver failure requiring liver transplant have been reported.

In 2-year placebo-controlled clinical trials in adult patients, elevation of liver enzymes (ALT, AST and GGT) to 3-fold the upper limit of normal (ULN) or greater occurred in 14% of patients treated with GILENYA 0.5 mg and 3% of patients on placebo. Elevations 5-fold the ULN or greater occurred in 4.5% of patients on GILENYA and 1% of patients on placebo. The majority of elevations occurred within 6 to 9 months. In clinical trials, GILENYA was discontinued if the elevation exceeded 5 times the ULN. Serum transaminase levels returned to normal within approximately 2 months after discontinuation of GILENYA. Recurrence of liver transaminase elevations occurred with rechallenge in some patients.

Prior to starting treatment with GILENYA (within 6 months), obtain serum transaminases (ALT and AST) and total bilirubin levels. Obtain transaminase levels and total bilirubin levels periodically until two months after GILENYA discontinuation.

Patients should be monitored for signs and symptoms of any hepatic injury. Measure liver transaminase and bilirubin levels promptly in patients who report symptoms that may indicate liver injury, including new or worsening fatigue, anorexia, right upper abdominal discomfort, dark urine, or jaundice. In this clinical context, if the patient is found to have an alanine aminotransferase (ALT) greater than three times the reference range with serum total bilirubin greater than two times the reference range, treatment with GILENYA treatment should be interrupted. Treatment should not be resumed if a plausible alternative etiology for the signs and symptoms cannot be established, because these patients are at risk for severe drug-induced liver injury.

Because GILENYA exposure is doubled in patients with severe hepatic impairment, these patients should be closely monitored, as the risk of adverse reactions is greater [see *Use in Specific Populations (8.6), Clinical Pharmacology (12.3)*].

5.6 Posterior Reversible Encephalopathy Syndrome

There have been rare cases of posterior reversible encephalopathy syndrome (PRES) reported in adult patients receiving GILENYA. Symptoms reported included sudden onset of severe headache, altered mental status, visual disturbances, and seizure. Symptoms of PRES are usually reversible but may evolve into ischemic stroke or cerebral hemorrhage. Delay in diagnosis and treatment may lead to permanent neurological sequelae. If PRES is suspected, GILENYA should be discontinued.

5.7 Respiratory Effects

Dose-dependent reductions in forced expiratory volume over 1 second (FEV1) and diffusion lung capacity for carbon monoxide (DLCO) were observed in patients treated with GILENYA as early as 1 month after treatment initiation. In 2-year placebo-controlled trials in adult patients, the reduction from baseline in the percent of predicted values for FEV1 at the time of last assessment on drug was 2.8% for GILENYA 0.5 mg and 1.0% for placebo. For DLCO, the reduction from baseline in percent of predicted values at the time of last assessment on drug was 3.3% for GILENYA 0.5 mg and 0.5% for placebo. The changes in FEV1 appear to be reversible after treatment discontinuation. There is insufficient information to determine the reversibility of the decrease of DLCO after drug discontinuation. In MS placebo-controlled trials in adult patients, dyspnea was reported in 9% of patients receiving GILENYA 0.5 mg and 7% of patients receiving placebo. Several patients discontinued GILENYA because of unexplained dyspnea during the extension (uncontrolled) studies. GILENYA has not been tested in MS patients with compromised respiratory function.

Spirometric evaluation of respiratory function and evaluation of DLCO should be performed during therapy with GILENYA if clinically indicated.

5.8 Fetal Risk

Based on findings from animal studies, GILENYA may cause fetal harm when administered to a pregnant woman. In animal reproduction studies conducted in rats and rabbits, developmental toxicity was observed with administration of fingolimod at doses less than the recommended human dose. Advise pregnant women and females of reproductive potential of the potential risk to a fetus. Because it takes approximately 2 months to eliminate GILENYA from the body, advise females of reproductive potential to use effective contraception to avoid pregnancy during and for 2 months after stopping GILENYA treatment [see *Use in Specific Populations* (8.1, 8.3)].

5.9 Severe Increase in Disability After Stopping GILENYA

Severe increase in disability accompanied by multiple new lesions on MRI has been reported after discontinuation of GILENYA in the postmarketing setting. Patients in most of these reported cases did not return to the functional status they had before stopping GILENYA. The increase in disability generally occurred within 12 weeks after stopping GILENYA, but was reported up to 24 weeks after GILENYA discontinuation.

Monitor patients for development of severe increase in disability following discontinuation of GILENYA and begin appropriate treatment as needed.

5.10 Tumefactive Multiple Sclerosis

MS relapses with tumefactive demyelinating lesions on imaging have been observed during GILENYA therapy and after GILENYA discontinuation in the postmarketing setting. Most reported cases of tumefactive MS in patients receiving Gilemya have occurred within the first 9 months after GILENYA initiation, but tumefactive MS may occur at any point during treatment. Cases of tumefactive MS have also been reported within the first 4 months after Gilemya discontinuation. Tumefactive MS should be considered when a severe MS relapse occurs during GILENYA treatment, especially during initiation, or after discontinuation of GILENYA, prompting imaging evaluation and initiation of appropriate treatment.

5.11 Increased Blood Pressure

In adult MS controlled clinical trials, patients treated with GILENYA 0.5 mg had an average increase over placebo of approximately 3 mmHg in systolic pressure, and approximately 2 mmHg in diastolic pressure, first detected after approximately 1 month of treatment initiation, and persisting with continued treatment. Hypertension was reported as an adverse reaction in 8% of patients on GILENYA 0.5 mg and in 4% of patients on placebo. Blood pressure should be monitored during treatment with GILENYA.

5.12 Malignancies

Cutaneous Malignancies

The risk of basal cell carcinoma (BCC) and melanoma is increased in patients treated with GILENYA. In two-year placebo-controlled trials in adult patients, the incidence of BCC was 2% in patients on GILENYA 0.5 mg and 1% in patients on placebo [see *Adverse Reactions* (6.1)]. Melanoma, squamous cell carcinoma and Merkel cell carcinoma have been reported with GILENYA in the postmarketing setting. Periodic skin examination is recommended for all patients, particularly those with risk factors for skin cancer. Providers and patients are advised to monitor for

suspicious skin lesions. If a suspicious skin lesion is observed, it should be promptly evaluated. As usual for patients with increased risk for skin cancer, exposure to sunlight and ultraviolet light should be limited by wearing protective clothing and using a sunscreen with a high protection factor.

Lymphoma

Cases of lymphoma, including both T-cell and B-cell types and CNS lymphoma, have occurred in patients receiving GILENYA. The reporting rate of non-Hodgkin lymphoma with GILENYA is greater than that expected in the general population adjusted by age, gender, and region. Cutaneous T-cell lymphoma (including mycosis fungoides) has also been reported with GILENYA in the postmarketing setting.

5.13 Immune System Effects Following GILENYA Discontinuation

Fingolimod remains in the blood and has pharmacodynamic effects, including decreased lymphocyte counts, for up to 2 months following the last dose of GILENYA. Lymphocyte counts generally return to the normal range within 1-2 months of stopping therapy [see *Clinical Pharmacology (12.2)*]. Because of the continuing pharmacodynamic effects of fingolimod, initiating other drugs during this period warrants the same considerations needed for concomitant administration (e.g., risk of additive immunosuppressant effects) [see *Drug Interactions (7.4)*].

5.14 Hypersensitivity Reactions

Hypersensitivity reactions, including rash, urticaria, and angioedema have been reported with GILENYA in the postmarketing setting. GILENYA is contraindicated in patients with history of hypersensitivity to fingolimod or any of its excipients [see *Contraindications (4)*].

6 ADVERSE REACTIONS

The following serious adverse reactions are described elsewhere in labeling:

- Bradyarrhythmia and Atrioventricular Blocks [see *Warnings and Precautions (5.1)*]
- Infections [see *Warnings and Precautions (5.2)*]
- Progressive Multifocal Leukoencephalopathy [see *Warnings and Precautions (5.3)*]
- Macular Edema [see *Warnings and Precautions (5.4)*]
- Liver Injury [see *Warnings and Precautions (5.5)*]
- Posterior Reversible Encephalopathy Syndrome [see *Warnings and Precautions (5.6)*]
- Respiratory Effects [see *Warnings and Precautions (5.7)*]
- Fetal Risk [see *Warnings and Precautions (5.8)*]
- Severe Increase in Disability After Stopping GILENYA [see *Warnings and Precautions (5.9)*]
- Tumefactive Multiple Sclerosis [see *Warnings and Precautions (5.10)*]
- Increased Blood Pressure [see *Warnings and Precautions (5.11)*]
- Malignancies [see *Warnings and Precautions (5.12)*]
- Immune System Effects Following GILENYA Discontinuation [see *Warnings and Precautions (5.13)*]
- Hypersensitivity Reactions [see *Warnings and Precautions (5.14)*]

6.1 Clinical Trials Experience

Because clinical trials are conducted under widely varying conditions, adverse reaction rates observed in the clinical trials of a drug cannot be directly compared to rates in the clinical trials of another drug and may not reflect the rates observed in practice.

Adults

In clinical trials (Studies 1, 2, and 3), a total of 1212 patients with relapsing forms of multiple sclerosis received GILENYA 0.5 mg. This included 783 patients who received GILENYA 0.5 mg in the 2-year placebo-controlled trials (Studies 1 and 3) and 429 patients who received GILENYA 0.5 mg in the 1-year active-controlled trial (Study 2). The overall exposure in the controlled trials was equivalent to 1716 person-years. Approximately 1000 patients received at least 2 years of treatment with GILENYA 0.5 mg. In all clinical studies, including uncontrolled extension studies, the exposure to GILENYA 0.5 mg was approximately 4119 person-years.

In placebo-controlled trials, the most frequent adverse reactions (incidence $\geq 10\%$ and greater than placebo) for GILENYA 0.5 mg were headache, liver transaminase elevation, diarrhea, cough, influenza, sinusitis, back pain, abdominal pain, and pain in extremity. Adverse events that led to treatment discontinuation and occurred in more than

1% of patients taking GILENYA 0.5 mg, were serum transaminase elevations (4.7% compared to 1% on placebo) and basal cell carcinoma (1% compared to 0.5% on placebo).

Table 1 lists adverse reactions in clinical studies in adults that occurred in $\geq 1\%$ of GILENYA-treated patients and $\geq 1\%$ higher rate than for placebo.

Table 1: Adverse Reactions Reported in Adult Studies 1 and 3 (Occurring in $\geq 1\%$ of Patients and Reported for GILENYA 0.5 mg at $\geq 1\%$ Higher Rate than for Placebo)

Adverse Drug Reactions	GILENYA 0.5 mg N = 783 %	Placebo N = 773 %
Infections		
Influenza	11	8
Sinusitis	11	8
Bronchitis	8	5
Herpes zoster	2	1
Tinea versicolor	2	< 1
Cardiac disorders		
Bradycardia	3	1
Nervous system disorders		
Headache	25	24
Migraine	6	4
Gastrointestinal disorders		
Nausea	13	12
Diarrhea	13	10
Abdominal pain	11	10
General disorders and administration-site conditions		
Asthenia	2	1
Musculoskeletal and connective tissue disorders		
Back pain	10	9
Pain in extremity	10	7
Skin and subcutaneous tissue disorders		
Alopecia	3	2
Actinic keratosis	2	1
Investigations		
Liver transaminase elevations (ALT/GGT/AST)	15	4
Blood triglycerides increased	3	1
Respiratory, thoracic, and mediastinal disorders		
Cough	12	11
Dyspnea	9	7
Eye disorders		
Vision blurred	4	2
Vascular disorders		
Hypertension	8	4
Blood and lymphatic system disorders		
Lymphopenia	7	< 1
Leukopenia	2	< 1

**Neoplasms benign, malignant, and unspecified
(including cysts and polyps)**

Skin papilloma	3	2
Basal cell carcinoma	2	1

Adverse reactions of seizure, dizziness, pneumonia, eczema, and pruritus were also reported in Studies 1 and 3, but did not meet the reporting rate criteria for inclusion in Table 1 (difference was less than 1%).

Adverse reactions with GILENYA 0.5 mg in Study 2, the 1-year active-controlled (versus interferon beta-1a) study were generally similar to those in Studies 1 and 3.

Vascular Events

Vascular events, including ischemic and hemorrhagic strokes, and peripheral arterial occlusive disease were reported in premarketing clinical trials in patients who received GILENYA doses (1.25-5 mg) higher than recommended for use in MS. Similar events have been reported with GILENYA in the postmarketing setting although a causal relationship has not been established.

Seizure

Cases of seizures, including status epilepticus, have been reported with the use of GILENYA in clinical trials and in the postmarketing setting in adults [see *Adverse Reactions (6.2)*]. In adult clinical trials, the rate of seizures was 0.9% in GILENYA-treated patients and 0.3% in placebo-treated patients. It is unknown whether these events were related to the effects of multiple sclerosis alone, to GILENYA, or to a combination of both.

Pediatric Patients 10 Years of Age and Older

In the controlled pediatric trial (Study 4), the safety profile in pediatric patients receiving GILENYA 0.25 mg or 0.5 mg daily was similar to that seen in adult patients.

In the pediatric study, cases of seizures were reported in 5.6% of GILENYA-treated patients and 0.9% of interferon beta-1a-treated patients [see *Use in Specific Populations (8.4)*].

6.2 Postmarketing Experience

The following adverse reactions have been identified during postapproval use of GILENYA. Because these reactions are reported voluntarily from a population of uncertain size, it is not always possible to reliably estimate their frequency or establish a causal relationship to drug exposure.

Blood and Lymphatic System Disorders: Hemolytic anemia and thrombocytopenia

Hepatobiliary Disorders: Liver injury [see *Warnings and Precautions (5.5)*]

Infections: infections including cryptococcal infections [see *Warnings and Precautions (5.2)*], human papilloma virus (HPV) infection, including papilloma, dysplasia, warts and HPV-related cancer [see *Warnings and Precautions (5.2)*], progressive multifocal leukoencephalopathy [see *Warnings and Precautions (5.3)*]

Musculoskeletal and connective tissue disorders: arthralgia, myalgia

Nervous system disorders: posterior reversible encephalopathy syndrome [see *Warnings and Precautions (5.6)*], seizures, including status epilepticus [see *Adverse Reactions (6.1)*]

Neoplasms, benign, malignant, and unspecified (including cysts and polyps): melanoma, Merkel cell carcinoma, and cutaneous T-cell lymphoma (including mycosis fungoides) [see *Warnings and Precautions (5.12)*]

Skin and subcutaneous tissue disorders: hypersensitivity [see *Warnings and Precautions (5.14)*]

7 DRUG INTERACTIONS

7.1 QT Prolonging Drugs

GILENYA has not been studied in patients treated with drugs that prolong the QT interval. Drugs that prolong the QT interval have been associated with cases of torsades de pointes in patients with bradycardia. Since initiation of

GILENYA treatment results in decreased heart rate and may prolong the QT interval, patients on QT prolonging drugs with a known risk of torsades de pointes (e.g., citalopram, chlorpromazine, haloperidol, methadone, erythromycin) should be monitored overnight with continuous ECG in a medical facility [see *Dosage and Administration (2.4), Warnings and Precautions (5.1)*].

7.2 Ketoconazole

The blood levels of fingolimod and fingolimod-phosphate are increased by 1.7-fold when used concomitantly with ketoconazole. Patients who use GILENYA and systemic ketoconazole concomitantly should be closely monitored, as the risk of adverse reactions is greater.

7.3 Vaccines

GILENYA reduces the immune response to vaccination. Vaccination may be less effective during and for up to 2 months after discontinuation of treatment with GILENYA [see *Clinical Pharmacology (12.2)*]. Avoid the use of live attenuated vaccines during and for 2 months after treatment with GILENYA because of the risk of infection. It is recommended that pediatric patients, if possible, be brought up to date with all immunizations in agreement with current immunization guidelines prior to initiating GILENYA therapy.

7.4 Antineoplastic, Immunosuppressive, or Immune-Modulating Therapies

Antineoplastic, immune-modulating, or immunosuppressive therapies, (including corticosteroids) are expected to increase the risk of immunosuppression, and the risk of additive immune system effects must be considered if these therapies are coadministered with GILENYA. When switching from drugs with prolonged immune effects, such as natalizumab, teriflunomide or mitoxantrone, the duration and mode of action of these drugs must be considered to avoid unintended additive immunosuppressive effects when initiating GILENYA [see *Warnings and Precautions (5.2)*].

7.5 Drugs That Slow Heart Rate or Atrioventricular Conduction (e.g., beta blockers or diltiazem)

Experience with GILENYA in patients receiving concurrent therapy with drugs that slow the heart rate or AV conduction (e.g., beta blockers, digoxin, or heart rate-slowing calcium channel blockers such as diltiazem or verapamil) is limited. Because initiation of GILENYA treatment may result in an additional decrease in heart rate, concomitant use of these drugs during GILENYA initiation may be associated with severe bradycardia or heart block. Seek advice from the physician prescribing these drugs regarding the possibility to switch to drugs that do not slow the heart rate or atrioventricular conduction before initiating GILENYA. Patients who cannot switch should have overnight continuous ECG monitoring after the first dose [see *Dosage and Administration (2.4), Warnings and Precautions (5.1)*].

7.6 Laboratory Test Interaction

Because GILENYA reduces blood lymphocyte counts via redistribution in secondary lymphoid organs, peripheral blood lymphocyte counts cannot be utilized to evaluate the lymphocyte subset status of a patient treated with GILENYA. A recent CBC should be available before initiating treatment with GILENYA.

8 USE IN SPECIFIC POPULATIONS

8.1 Pregnancy

Pregnancy Exposure Registry

There is a pregnancy exposure registry that monitors pregnancy outcomes in women exposed to GILENYA during pregnancy. Physicians are encouraged to enroll pregnant patients, or pregnant women may register themselves in the GILENYA pregnancy registry by calling 1-877-598-7237, sending an email to gpr@quintiles.com, or visiting www.gilenyapregnancyregistry.com.

Risk Summary

Based on findings from animal studies, GILENYA may cause fetal harm when administered to a pregnant woman. Data from prospective reports to the Gilenya Pregnancy Registry (GPR) are currently not sufficient to allow for an adequate assessment of the drug-associated risk for birth defects and miscarriage in humans.

In oral studies conducted in rats and rabbits, fingolimod demonstrated developmental toxicity, including an increase in malformations (rats) and embryoletality, when given to pregnant animals. In rats, the highest no-effect dose was less than the recommended human dose of 0.5 mg/day on a body surface area (mg/m²) basis. The most common fetal

visceral malformations in rats were persistent truncus arteriosus and ventricular septal defect. The receptor affected by fingolimod (sphingosine 1-phosphate receptor) is known to be involved in vascular formation during embryogenesis (*see Data*). Advise pregnant women of the potential risk to a fetus.

In the US general population, the estimated background risk of major birth defects and miscarriage in clinically recognized pregnancies is 2%-4% and 15%-20%, respectively. The background risk of major birth defects and miscarriage for the indicated population is unknown. Clinical Considerations

In females planning to become pregnant, GILENYA should be stopped 2 months before planned conception.

The possibility of severe increase in disability should be considered in women who discontinue or are considering discontinuation of GILENYA because of pregnancy or planned pregnancy. In many of the cases in which increase in disability was reported after stopping GILENYA, patients had stopped GILENYA because of pregnancy or planned pregnancy [*see Warnings and Precautions (5.9)*].

Data

Animal Data

When fingolimod was orally administered to pregnant rats during the period of organogenesis (0, 0.03, 0.1, and 0.3 mg/kg/day or 0, 1, 3, and 10 mg/kg/day), increased incidences of fetal malformations and embryofetal deaths were observed at all but the lowest dose tested (0.03 mg/kg/day), which is less than the recommended human dose (RHD) on a mg/m² basis. Oral administration to pregnant rabbits during organogenesis (0, 0.5, 1.5, and 5 mg/kg/day) resulted in increased incidences of embryofetal mortality and fetal growth retardation at the mid and high doses. The no-effect dose for these effects in rabbits (0.5 mg/kg/day) is approximately 20 times the RHD on a mg/m² basis.

When fingolimod was orally administered to female rats during pregnancy and lactation (0, 0.05, 0.15, and 0.5 mg/kg/day), pup survival was decreased at all doses and a neurobehavioral (learning) deficit was seen in offspring at the high dose. The low-effect dose of 0.05 mg/kg/day is similar to the RHD on a mg/m² basis.

8.2 Lactation

Risk Summary

There are no data on the presence of fingolimod in human milk, the effects on the breastfed infant, or the effects of the drug on milk production. Fingolimod is excreted in the milk of treated rats. When a drug is present in animal milk, it is likely that the drug will be present in human milk. The developmental and health benefits of breastfeeding should be considered along with the mother's clinical need for GILENYA and any potential adverse effects on the breastfed infant from GILENYA or from the underlying maternal condition.

8.3 Females and Males of Reproductive Potential

Pregnancy Testing

The pregnancy status of females of reproductive potential should be verified prior to starting treatment with GILENYA [*see Use in Specific Populations (8.1)*].

Contraception

Before initiation of GILENYA treatment, females of reproductive potential should be counseled on the potential for a serious risk to the fetus and the need for effective contraception during treatment with GILENYA [*see Warnings and Precautions (5.8) and Use in Specific Populations (8.1)*]. Since it takes approximately 2 months to eliminate the compound from the body after stopping treatment, the potential risk to the fetus may persist and women should use effective contraception during this period [*see Warnings and Precautions (5.8, 5.13)*].

8.4 Pediatric Use

Safety and effectiveness of GILENYA for the treatment of relapsing forms of multiple sclerosis in pediatric patients 10 to less than 18 years of age were established in one randomized, double-blind clinical study in 215 patients (GILENYA n = 107; intramuscular interferon (IFN) beta-1a n = 108) [*see Clinical Studies (14.2)*].

In the controlled pediatric study, the safety profile in pediatric patients (10 to less than 18 years of age) receiving GILENYA 0.25 mg or 0.5 mg daily was similar to that seen in adult patients. In the pediatric study, cases of seizures were reported in 5.6% of GILENYA-treated patients and 0.9% of interferon beta-1a-treated patients.

It is recommended that pediatric patients, if possible, complete all immunizations in accordance with current immunization guidelines prior to initiating GILENYA therapy.

Safety and effectiveness of GILENYA in pediatric patients below the age of 10 years have not been established.

Juvenile Animal Toxicity Data

In a study in which fingolimod (0.3, 1.5, or 7.5 mg/kg/day) was orally administered to young rats from weaning through sexual maturity, changes in bone mineral density and persistent neurobehavioral impairment (altered auditory startle) were observed at all doses. Delayed sexual maturation was noted in females at the highest dose tested and in males at all doses. The bone changes observed in fingolimod-treated juvenile rats are consistent with a reported role of S1P in the regulation of bone mineral homeostasis.

When fingolimod (0.5 or 5 mg/kg/day) was orally administered to rats from the neonatal period through sexual maturity, a marked decrease in T-cell dependent antibody response was observed at both doses. This effect had not fully recovered by 6-8 weeks after the end of treatment.

Overall, a no-effect dose for adverse developmental effects in juvenile animals was not identified.

8.5 Geriatric Use

Clinical MS studies of GILENYA did not include sufficient numbers of patients aged 65 years and over to determine whether they respond differently than younger patients. GILENYA should be used with caution in patients aged 65 years and over, reflecting the greater frequency of decreased hepatic, or renal, function and of concomitant disease or other drug therapy.

8.6 Hepatic Impairment

Because fingolimod, but not fingolimod-phosphate, exposure is doubled in patients with severe hepatic impairment, patients with severe hepatic impairment should be closely monitored, as the risk of adverse reactions may be greater [see *Warnings and Precautions (5.5), Clinical Pharmacology (12.3)*].

No dose adjustment is needed in patients with mild or moderate hepatic impairment.

8.7 Renal Impairment

The blood level of some GILENYA metabolites is increased (up to 13-fold) in patients with severe renal impairment [see *Clinical Pharmacology (12.3)*]. The toxicity of these metabolites has not been fully explored. The blood level of these metabolites has not been assessed in patients with mild or moderate renal impairment.

10 OVERDOSAGE

GILENYA can induce bradycardia as well as AV conduction blocks (including complete AV block). The decline in heart rate usually starts within 1 hour of the first dose and is maximal within 6 hours in most patients [see *Warnings and Precautions (5.1)*]. In case of GILENYA overdosage, observe patients overnight with continuous ECG monitoring in a medical facility, and obtain regular measurements of blood pressure [see *Dosage and Administration (2.4)*].

Neither dialysis nor plasma exchange results in removal of fingolimod from the body.

11 DESCRIPTION

Fingolimod is a sphingosine 1-phosphate receptor modulator.

Chemically, fingolimod is 2-amino-2-[2-(4-octylphenyl)ethyl]propan-1,3-diol hydrochloride. Its structure is shown below:

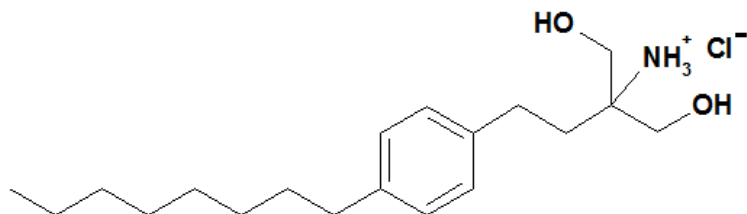

Fingolimod hydrochloride is a white to practically white powder that is freely soluble in water and alcohol and soluble in propylene glycol. It has a molecular weight of 343.93 g/mol.

GILENYA is provided as 0.25 mg and 0.5 mg hard gelatin capsules for oral use.

Each 0.25 mg capsule contains 0.28 mg of fingolimod hydrochloride, equivalent to 0.25 mg fingolimod.

Each 0.5 mg capsule contains 0.56 mg of fingolimod hydrochloride, equivalent to 0.5 mg of fingolimod.

Each GILENYA 0.25 mg capsule contains the following inactive ingredients: gelatin, hydroxypropylbetadex, hydroxypropylcellulose, magnesium stearate, mannitol, titanium dioxide, and yellow iron oxide.

Each GILENYA 0.5 mg capsule contains the following inactive ingredients: gelatin, magnesium stearate, mannitol, titanium dioxide, and yellow iron oxide.

12 CLINICAL PHARMACOLOGY

12.1 Mechanism of Action

Fingolimod is metabolized by sphingosine kinase to the active metabolite, fingolimod-phosphate. Fingolimod-phosphate is a sphingosine 1-phosphate receptor modulator, and binds with high affinity to sphingosine 1-phosphate receptors 1, 3, 4, and 5. Fingolimod-phosphate blocks the capacity of lymphocytes to egress from lymph nodes, reducing the number of lymphocytes in peripheral blood. The mechanism by which fingolimod exerts therapeutic effects in multiple sclerosis is unknown, but may involve reduction of lymphocyte migration into the central nervous system.

12.2 Pharmacodynamics

Heart Rate and Rhythm

Fingolimod causes a transient reduction in heart rate and AV conduction at treatment initiation [*see Warnings and Precautions (5.1)*].

Heart rate progressively increases after the first day, returning to baseline values within 1 month of the start of chronic treatment.

Autonomic responses of the heart, including diurnal variation of heart rate and response to exercise, are not affected by fingolimod treatment.

Fingolimod treatment is not associated with a decrease in cardiac output.

Potential to Prolong the QT Interval

In a thorough QT interval study of doses of 1.25 or 2.5 mg fingolimod at steady-state, when a negative chronotropic effect of fingolimod was still present, fingolimod treatment resulted in a prolongation of QTc, with the upper boundary of the 90% confidence interval (CI) of 14.0 msec. There is no consistent signal of increased incidence of QTc outliers, either absolute or change from baseline, associated with fingolimod treatment. In MS studies, there was no clinically relevant prolongation of the QT interval, but patients at risk for QT prolongation were not included in clinical studies.

Immune System

Effects on Immune Cell Numbers in the Blood

In a study in which 12 adult subjects received GILENYA 0.5 mg daily, the lymphocyte count decreased to approximately 60% of baseline within 4 to 6 hours after the first dose. With continued daily dosing, the lymphocyte count continued to decrease over a 2-week period, reaching a nadir count of approximately 500 cells/mcL or approximately 30% of baseline. In a placebo-controlled study in 1272 MS patients (of whom 425 received fingolimod 0.5 mg daily and 418 received placebo), 18% (N = 78) of patients on fingolimod 0.5 mg reached a nadir of < 200 cells/mcL on at least 1 occasion. No patient on placebo reached a nadir of < 200 cells/mcL. Low lymphocyte counts are maintained with chronic daily dosing of GILENYA 0.5 mg daily.

Chronic fingolimod dosing leads to a mild decrease in the neutrophil count to approximately 80% of baseline. Monocytes are unaffected by fingolimod.

Peripheral lymphocyte count increases are evident within days of stopping fingolimod treatment and typically normal counts are reached within 1 to 2 months.

Effect on Antibody Response

GILENYA reduces the immune response to vaccination, as evaluated in 2 studies.

In the first study, the immunogenicity of keyhole limpet hemocyanin (KLH) and pneumococcal polysaccharide vaccine (PPV-23) immunization were assessed by IgM and IgG titers in a steady-state, randomized, placebo-controlled study in healthy adult volunteers. Compared to placebo, antigen-specific IgM titers were decreased by 91% and 25% in response to KLH and PPV-23, respectively, in subjects on GILENYA 0.5 mg. Similarly, IgG titers were decreased by 45% and 50%, in response to KLH and PPV-23, respectively, in subjects on GILENYA 0.5 mg daily compared to placebo. The responder rate for GILENYA 0.5 mg as measured by the number of subjects with a > 4-fold increase in KLH IgG was comparable to placebo and 25% lower for PPV-23 IgG, while the number of subjects with a > 4-fold increase in KLH and PPV-23 IgM was 75% and 40% lower, respectively, compared to placebo. The capacity to mount a skin delayed-type hypersensitivity reaction to *Candida* and tetanus toxoid was decreased by approximately 30% in subjects on GILENYA 0.5 mg daily, compared to placebo. Immunologic responses were further decreased with fingolimod 1.25 mg (a dose higher than recommended in MS) [see *Warnings and Precautions (5.2)*].

In the second study, the immunogenicity of Northern hemisphere seasonal influenza and tetanus toxoid vaccination was assessed in a 12-week steady-state, randomized, placebo-controlled study of GILENYA 0.5 mg in adult multiple sclerosis patients (n = 136). The responder rate 3 weeks after vaccination, defined as seroconversion or a ≥ 4 -fold increase in antibody directed against at least 1 of the 3 influenza strains, was 54% for GILENYA 0.5 mg and 85% in the placebo group. The responder rate 3 weeks after vaccination, defined as seroconversion or a ≥ 4 -fold increase in antibody directed against tetanus toxoid was 40% for GILENYA 0.5 mg and 61% in the placebo group.

Pulmonary Function

Single fingolimod doses ≥ 5 mg (10-fold the recommended dose) are associated with a dose-dependent increase in airway resistance. In a 14-day study of 0.5, 1.25, or 5 mg/day, fingolimod was not associated with impaired oxygenation or oxygen desaturation with exercise or an increase in airway responsiveness to methacholine. Subjects on fingolimod treatment had a normal bronchodilator response to inhaled beta-agonists.

In a 14-day placebo-controlled study of adult patients with moderate asthma, no effect was seen for GILENYA 0.5 mg (recommended dose in MS). A 10% reduction in mean FEV1 at 6 hours after dosing was observed in adult patients receiving fingolimod 1.25 mg (a dose higher than recommended for use in MS) on Day 10 of treatment. Fingolimod 1.25 mg was associated with a 5-fold increase in the use of rescue short-acting beta-agonists.

12.3 Pharmacokinetics

Absorption

The T_{max} of fingolimod is 12–16 hours. The apparent absolute oral bioavailability is 93%.

Food intake does not alter C_{max} or (AUC) of fingolimod or fingolimod-phosphate. Therefore, GILENYA may be taken without regard to meals.

Steady-state blood concentrations are reached within 1 to 2 months following once-daily administration and steady-state levels are approximately 10-fold greater than with the initial dose.

Distribution

Fingolimod highly (86%) distributes in red blood cells. Fingolimod-phosphate has a smaller uptake in blood cells of < 17%. Fingolimod and fingolimod-phosphate are > 99.7% protein bound. Fingolimod and fingolimod-phosphate protein binding is not altered by renal or hepatic impairment.

Fingolimod is extensively distributed to body tissues with a volume of distribution of about 1200 ± 260 L.

Metabolism

The biotransformation of fingolimod in humans occurs by 3 main pathways: by reversible stereoselective phosphorylation to the pharmacologically active (*S*)-enantiomer of fingolimod-phosphate, by oxidative biotransformation catalyzed mainly by the cytochrome P450 4F2 (CYP4F2) and possibly other CYP4F isoenzymes

with subsequent fatty acid-like degradation to inactive metabolites, and by formation of pharmacologically inactive non-polar ceramide analogs of fingolimod.

Inhibitors or inducers of CYP4F2 and possibly other CYP4F isozymes might alter the exposure of fingolimod or fingolimod-phosphate. *In vitro* studies in hepatocytes indicated that CYP3A4 may contribute to fingolimod metabolism in the case of strong induction of CYP3A4.

Following single oral administration of [¹⁴C] fingolimod, the major fingolimod-related components in blood, as judged from their contribution to the AUC up to 816 hours post-dose of total radiolabeled components, are fingolimod itself (23.3%), fingolimod-phosphate (10.3%), and inactive metabolites [M3 carboxylic acid metabolite (8.3%), M29 ceramide metabolite (8.9%), and M30 ceramide metabolite (7.3%)].

Elimination

Fingolimod blood clearance is 6.3 ± 2.3 L/h, and the average apparent terminal half-life ($t_{1/2}$) is 6 to 9 days. Blood levels of fingolimod-phosphate decline in parallel with those of fingolimod in the terminal phase, yielding similar half-lives for both.

After oral administration, about 81% of the dose is slowly excreted in the urine as inactive metabolites. Fingolimod and fingolimod-phosphate are not excreted intact in urine but are the major components in the feces with amounts of each representing less than 2.5% of the dose.

Specific Populations

Pediatric Patients

The median fingolimod-phosphate (fingolimod-P) concentration in pediatric MS patients aged 10 to less than 18 years was 1.10 ng/mL, as compared to 1.35 ng/mL in adult MS patients.

Geriatric Patients

The mechanism for elimination and results from population pharmacokinetics suggest that dose adjustment would not be necessary in elderly patients. However, clinical experience in patients aged above 65 years is limited.

Gender

Gender has no clinically significant influence on fingolimod and fingolimod-phosphate pharmacokinetics.

Race

The effects of race on fingolimod and fingolimod-phosphate pharmacokinetics cannot be adequately assessed due to a low number of non-white patients in the clinical program.

Renal Impairment

In adult patients with severe renal impairment, fingolimod C_{max} and AUC are increased by 32% and 43%, respectively, and fingolimod-phosphate C_{max} and AUC are increased by 25% and 14%, respectively, with no change in apparent elimination half-life. Based on these findings, the GILENYA 0.5 mg dose is appropriate for use in adult patients with renal impairment. GILENYA 0.25 mg and 0.5 mg are appropriate for use in pediatric patients with renal impairment. The systemic exposure of 2 metabolites (M2 and M3) is increased by 3- and 13-fold, respectively. The toxicity of these metabolites has not been fully characterized.

A study in patients with mild or moderate renal impairment has not been conducted.

Hepatic Impairment

In subjects with mild, moderate, or severe hepatic impairment (Child-Pugh class A, B, and C), no change in fingolimod C_{max} was observed, but fingolimod $AUC_{0-\infty}$ was increased respectively by 12%, 44%, and 103%. In patients with severe hepatic impairment (Child-Pugh class C), fingolimod-phosphate C_{max} was decreased by 22% and $AUC_{0-96 \text{ hours}}$ was decreased by 29%. The pharmacokinetics of fingolimod-phosphate was not evaluated in patients with mild or moderate hepatic impairment. The apparent elimination half-life of fingolimod is unchanged in subjects with mild hepatic impairment, but is prolonged by about 50% in patients with moderate or severe hepatic impairment.

Patients with severe hepatic impairment (Child-Pugh class C) should be closely monitored, as the risk of adverse reactions is greater [*see Warnings and Precautions (5.5)*].

No dose adjustment is needed in patients with mild or moderate hepatic impairment (Child-Pugh class A and B).

Drug Interactions

Ketoconazole

The coadministration of ketoconazole (a potent inhibitor of CYP3A and CYP4F) 200 mg twice-daily at steady-state and a single dose of fingolimod 5 mg led to a 70% increase in AUC of fingolimod and fingolimod-phosphate. Patients who use GILENYA and systemic ketoconazole concomitantly should be closely monitored, as the risk of adverse reactions is greater [see *Drug Interactions (7.2)*].

Carbamazepine

The coadministration of carbamazepine (a potent CYP450 enzyme inducer) 600 mg twice-daily at steady-state and a single dose of fingolimod 2 mg decreased blood concentrations (AUC) of fingolimod and fingolimod-phosphate by approximately 40%. The clinical impact of this decrease is unknown.

Other strong CYP450 enzyme inducers, e.g., rifampicin, phenytoin, phenobarbital, and St. John's wort, may also reduce AUC of fingolimod and fingolimod-phosphate. The clinical impact of this potential decrease is unknown.

Potential of Fingolimod and Fingolimod-phosphate to Inhibit the Metabolism of Comedications

In vitro inhibition studies using pooled human liver microsomes and specific metabolic probe substrates demonstrate that fingolimod has little or no capacity to inhibit the activity of the following CYP enzymes: CYP1A2, CYP2A6, CYP2B6, CYP2C8, CYP2C9, CYP2C19, CYP2D6, CYP2E1, CYP3A4/5, or CYP4A9/11 (fingolimod only), and similarly fingolimod-phosphate has little or no capacity to inhibit the activity of CYP1A2, CYP2A6, CYP2B6, CYP2C8, CYP2C9, CYP2C19, CYP2D6, CYP2E1, or CYP3A4 at concentrations up to 3 orders of magnitude of therapeutic concentrations. Therefore, fingolimod and fingolimod-phosphate are unlikely to reduce the clearance of drugs that are mainly cleared through metabolism by the major CYP isoenzymes described above.

Potential of Fingolimod and Fingolimod-phosphate to Induce its Own and/or the Metabolism of Comedications

Fingolimod was examined for its potential to induce human CYP3A4, CYP1A2, CYP4F2, and MDR1 (P-glycoprotein) mRNA and CYP3A, CYP1A2, CYP2B6, CYP2C8, CYP2C9, CYP2C19, and CYP4F2 activity in primary human hepatocytes. Fingolimod did not induce mRNA or activity of the different CYP enzymes and MDR1 with respect to the vehicle control; therefore, no clinically relevant induction of the tested CYP enzymes or MDR1 by fingolimod are expected at therapeutic concentrations. Fingolimod-phosphate was also examined for its potential to induce mRNA and/or activity of human CYP1A2, CYP2B6, CYP2C8, CYP2C9, CYP2C19, CYP3A, CYP4F2, CYP4F3B, and CYP4F12. Fingolimod-phosphate is not expected to have clinically significant induction effects on these enzymes at therapeutic doses of fingolimod. *In vitro* experiments did not provide an indication of CYP induction by fingolimod-phosphate.

Transporters

Based on *in vitro* data, fingolimod as well as fingolimod-phosphate are not expected to inhibit the uptake of comedications and/or biologics transported by the organic anion transporting polypeptides OATP1B1, OATP1B3, or the sodium taurocholate co-transporting polypeptide (NTCP). Similarly, they are not expected to inhibit the efflux of comedications and/or biologics transported by the breast cancer resistance protein (BCRP), the bile salt export pump (BSEP), the multidrug resistance-associated protein 2 (MRP2), or P-glycoprotein (P-gp) at therapeutic concentrations.

Oral Contraceptives

The coadministration of fingolimod 0.5 mg daily with oral contraceptives (ethinylestradiol and levonorgestrel) did not elicit any clinically significant change in oral contraceptives exposure. Fingolimod and fingolimod-phosphate exposure were consistent with those from previous studies. No interaction studies have been performed with oral contraceptives containing other progestagens; however, an effect of fingolimod on their exposure is not expected.

Cyclosporine

The pharmacokinetics of single-dose fingolimod was not altered during coadministration with cyclosporine at steady-state, nor was cyclosporine steady-state pharmacokinetics altered by fingolimod. These data indicate that GILENYA is unlikely to reduce or increase the clearance of drugs cleared mainly by CYP3A4. Potent inhibition of transporters MDR1 (P-gp), MRP2, and OATP-1B1 does not influence fingolimod disposition.

Isoproterenol, Atropine, Atenolol, and Diltiazem

Single-dose fingolimod and fingolimod-phosphate exposure was not altered by coadministered isoproterenol or atropine. Likewise, the single-dose pharmacokinetics of fingolimod and fingolimod-phosphate and the steady-state pharmacokinetics of both atenolol and diltiazem were unchanged during the coadministration of the latter 2 drugs individually with fingolimod.

Population Pharmacokinetics Analysis

A population pharmacokinetics evaluation performed in MS patients did not provide evidence for a significant effect of fluoxetine and paroxetine (strong CYP2D6 inhibitors) on fingolimod or fingolimod-phosphate predose concentrations. In addition, the following commonly coprescribed substances had no clinically relevant effect (< 20%) on fingolimod or fingolimod-phosphate predose concentrations: baclofen, gabapentin, oxybutynin, amantadine, modafinil, amitriptyline, pregabalin, and corticosteroids.

13 NONCLINICAL TOXICOLOGY

13.1 Carcinogenesis, Mutagenesis, Impairment of Fertility

Oral carcinogenicity studies of fingolimod were conducted in mice and rats. In mice, fingolimod was administered at oral doses of 0, 0.025, 0.25, and 2.5 mg/kg/day for up to 2 years. The incidence of malignant lymphoma was increased in males and females at the mid and high dose. The lowest dose tested (0.025 mg/kg/day) is less than the RHD of 0.5 mg/day on a body surface area (mg/m²) basis. In rats, fingolimod was administered at oral doses of 0, 0.05, 0.15, 0.5, and 2.5 mg/kg/day. No increase in tumors was observed. The highest dose tested (2.5 mg/kg/day) is approximately 50 times the RHD on a mg/m² basis.

Fingolimod was negative in a battery of *in vitro* (Ames, mouse lymphoma thymidine kinase, chromosomal aberration in mammalian cells) and *in vivo* (micronucleus in mouse and rat) assays.

When fingolimod was administered orally (0, 1, 3, and 10 mg/kg/day) to male and female rats prior to and during mating, and continuing to Day 7 of gestation in females, no effect on fertility was observed up to the highest dose tested (10 mg/kg), which is approximately 200 times the RHD on a mg/m² basis.

13.2 Animal Toxicology and/or Pharmacology

Lung toxicity was observed in 2 different strains of rats and in dogs and monkeys. The primary findings included increase in lung weight, associated with smooth muscle hypertrophy, hyperdistention of the alveoli, and/or increased collagen. Insufficient or lack of pulmonary collapse at necropsy, generally correlated with microscopic changes, was observed in all species. In rats and monkeys, lung toxicity was observed at all oral doses tested in chronic studies. The lowest doses tested in rats (0.05 mg/kg/day in the 2-year carcinogenicity study) and monkeys (0.5 mg/kg/day in the 39-week toxicity study) are similar to and approximately 20 times the RHD on a mg/m² basis, respectively.

In the 52-week oral study in monkeys, respiratory distress associated with ketamine administration was observed at doses of 3 and 10 mg/kg/day; the most affected animal became hypoxic and required oxygenation. As ketamine is not generally associated with respiratory depression, this effect was attributed to fingolimod. In a subsequent study in rats, ketamine was shown to potentiate the bronchoconstrictive effects of fingolimod. The relevance of these findings to humans is unknown.

14 CLINICAL STUDIES

14.1 Adults

The efficacy of GILENYA was demonstrated in 2 studies that evaluated once-daily doses of GILENYA 0.5 mg and 1.25 mg in patients with relapsing-remitting MS (RRMS). Both studies included patients who had experienced at least 2 clinical relapses during the 2 years prior to randomization or at least 1 clinical relapse during the 1 year prior to randomization, and had an Expanded Disability Status Scale (EDSS) score from 0 to 5.5. Study 1 was a 2-year randomized, double-blind, placebo-controlled study in patients with RRMS who had not received any interferon-beta or glatiramer acetate for at least the previous 3 months and had not received any natalizumab for at least the previous 6 months. Neurological evaluations were performed at screening, every 3 months and at time of suspected relapse. MRI evaluations were performed at screening, Month 6, Month 12, and Month 24. The primary endpoint was the annualized relapse rate.

Median age was 37 years, median disease duration was 6.7 years and median EDSS score at baseline was 2.0. Patients were randomized to receive GILENYA 0.5 mg (N = 425), 1.25 mg (N = 429), or placebo (N = 418) for up to 24 months. Median time on study drug was 717 days on 0.5 mg, 715 days on 1.25 mg, and 719 days on placebo.

The annualized relapse rate was significantly lower in patients treated with GILENYA than in patients who received placebo. The secondary endpoint was the time to 3-month confirmed disability progression as measured by at least a 1-point increase from baseline in EDSS (0.5-point increase for patients with baseline EDSS of 5.5) sustained for 3 months. Time to onset of 3-month confirmed disability progression was significantly delayed with GILENYA treatment compared to placebo. The 1.25 mg dose resulted in no additional benefit over the GILENYA 0.5 mg dose. The results for this study are shown in Table 2 and Figure 1.

Table 2: Clinical and MRI Results of Study 1

	GILENYA 0.5 mg N = 425	Placebo N = 418	p-value
Clinical Endpoints			
Annualized relapse rate (primary endpoint)	0.18	0.40	< 0.001
Percentage of patients without relapse	70%	46%	< 0.001
Hazard ratio [‡] of disability progression (95% CI)	0.70 (0.52, 0.96)		0.02
MRI Endpoint			
Mean (median) number of new or newly enlarging T2 lesions over 24 months	2.5 (0)	9.8 (5.0)	< 0.001
Mean (median) number of T1 Gd-enhancing lesions at Month 24	0.2 (0)	1.1 (0)	< 0.001

All analyses of clinical endpoints were intent-to-treat. MRI analysis used evaluable dataset.

[‡]Hazard ratio is an estimate of the relative risk of having the event of disability progression on GILENYA as compared to placebo.

Figure 1: Time to 3-Month Confirmed Disability Progression – Study 1 (ITT population)

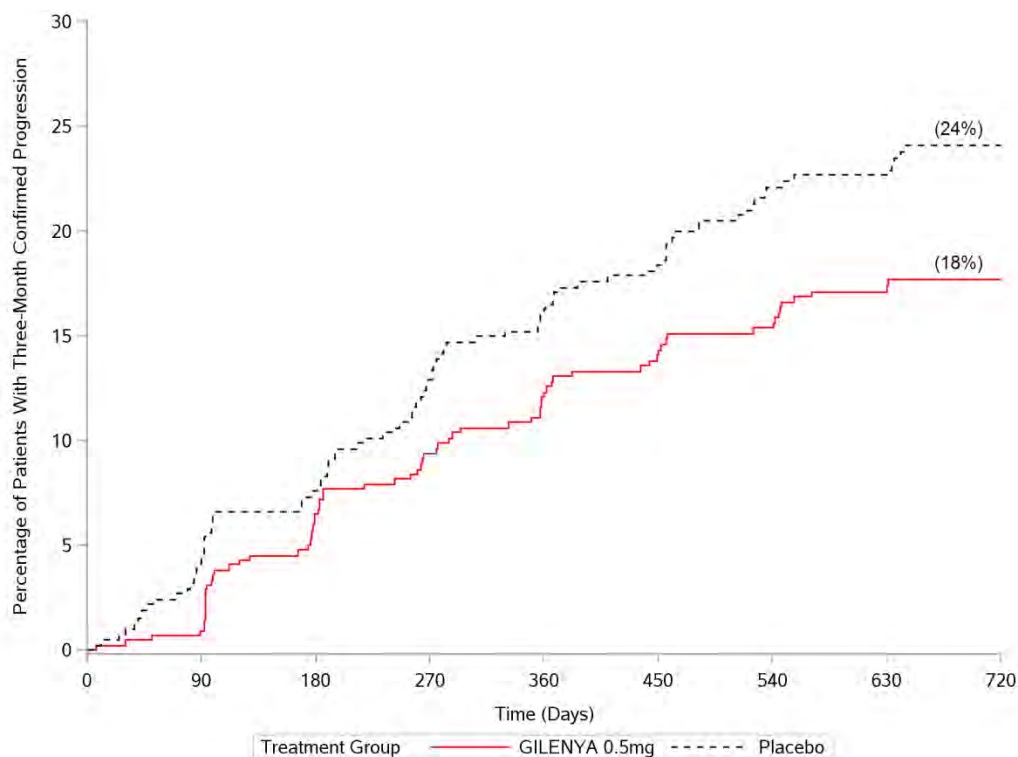

Study 2 was a 1-year randomized, double-blind, double-dummy, active-controlled study in patients with RRMS who had not received any natalizumab in the previous 6 months. Prior therapy with interferon-beta or glatiramer acetate up to the time of randomization was permitted.

Neurological evaluations were performed at screening, every 3 months, and at the time of suspected relapses. MRI evaluations were performed at screening and at Month 12. The primary endpoint was the annualized relapse rate.

Median age was 36 years, median disease duration was 5.9 years, and median EDSS score at baseline was 2.0. Patients were randomized to receive GILENYA 0.5 mg (N = 431), 1.25 mg (N = 426), or interferon beta-1a, 30 mcg via the intramuscular route (IM) once-weekly (N = 435) for up to 12 months. Median time on study drug was 365 days on GILENYA 0.5 mg, 354 days on 1.25 mg, and 361 days on interferon beta-1a IM.

The annualized relapse rate was significantly lower in patients treated with GILENYA 0.5 mg than in patients who received interferon beta-1a IM. The key secondary endpoints were number of new and newly enlarging T2 lesions and time to onset of 3-month confirmed disability progression as measured by at least a 1-point increase from baseline in EDSS (0.5-point increase for those with baseline EDSS of 5.5) sustained for 3 months. The number of new and newly enlarging T2 lesions was significantly lower in patients treated with GILENYA than in patients who received interferon beta-1a IM. There was no significant difference in the time to 3-month confirmed disability progression between GILENYA and interferon beta-1a-treated patients at 1 year. The 1.25 mg dose resulted in no additional benefit over the GILENYA 0.5 mg dose. The results for this study are shown in Table 3.

Table 3: Clinical and MRI Results of Study 2

	GILENYA	Interferon beta-1a	p-value
	0.5 mg	IM 30 mcg	
	N = 429	N = 431	
Clinical Endpoints			
Annualized relapse rate (primary endpoint)	0.16	0.33	< 0.001
Percentage of patients without relapse	83%	70%	< 0.001
Hazard ratio [‡] of disability progression (95% CI)	0.71 (0.42, 1.21)		0.21
MRI Endpoint			
Mean (median) number of new or newly enlarging T2 lesions over 12 months	1.6 (0)	2.6 (1.0)	0.002
Mean (median) number of T1 Gd-enhancing lesions at Month 12	0.2 (0)	0.5 (0)	< 0.001

All analyses of clinical endpoints were intent-to-treat. MRI analysis used evaluable dataset.

[‡] Hazard ratio is an estimate of the relative risk of having the event of disability progression on GILENYA as compared to control.

Pooled results of study 1 and study 2 showed a consistent and statistically significant reduction of annualized relapse rate compared to comparator in subgroups defined by gender, age, prior MS therapy, and disease activity.

14.2 Pediatric Patients (10 to less than 18 Years of Age)

Study 4 (NCT 01892722) evaluated the efficacy of once-daily oral doses of GILENYA 0.25 mg or GILENYA 0.5 mg in pediatric patients 10 to less than 18 years of age with relapsing-remitting multiple sclerosis. Study 4 was a 215-patient, double-blind, randomized, clinical trial that compared GILENYA to intramuscular interferon beta-1a. Prior therapy with interferon-beta, dimethyl fumarate, or glatiramer acetate up to the time of randomization was permitted. The study included patients who had experienced at least 1 clinical relapse during the year prior or 2 relapses during the 2 years prior to screening, or evidence of 1 or more Gd-enhancing lesions on MRI within 6 months prior to randomization, and had an EDSS score from 0 to 5.5. Neurological evaluations were scheduled at screening, every 3 months, and at the time of suspected relapses. MRI evaluations were performed at screening and every 6 months throughout the study. The primary endpoint was the annualized relapse rate.

At baseline, the median age was 16 years, median disease duration since first symptom was 1.5 years, and median EDSS score was 1.5. One patient received no study drug and is excluded from the analysis of efficacy. Median duration of exposure to study drug was 634 days in the GILENYA group (n = 107) and 547 days in the interferon beta-1a group (n = 107). In the GILENYA group, 6.5% of patients did not complete the study, compared to 18.5% in the interferon beta-1a group.

The primary endpoint, the annualized relapse rate (ARR), was significantly lower in patients treated with GILENYA (0.122) than in patients who received interferon beta-1a (0.675). Relative reduction in ARR was 81.9%. The annualized rate of the number of new or newly enlarged T2 lesions up to month 24 (key secondary endpoint) was significantly lower in patients treated with GILENYA, as was the number of Gd-enhancing T1 lesions per scan up to month 24.

Table 4 summarizes the results of Study 4.

Table 4: Clinical and MRI Results of Study 4

	GILENYA 0.25 or 0.5 mg PO N = 107	Interferon beta-1a 30 mcg IM N = 107	p-value	Relative Reduction
Clinical endpoints				
Annualized relapse rate (primary endpoint)	0.122	0.675	< 0.001*	81.9%
Percent of patients remaining relapse-free at 24 months	86.0%	45.8%		
MRI endpoints				
Annualized rate of the number of new or newly enlarging T2 lesions	4.393	9.269	< 0.001*	52.6%
Mean number of Gd-enhancing T1 lesions per scan up to Month 24	0.436	1.282	< 0.001*	66.0%

All analyses of clinical endpoints were on full analysis set. MRI analyses used the evaluable dataset.

*Indicates statistical significance vs. Interferon beta-1a IM at two-sided 0.05 level.

16 HOW SUPPLIED/STORAGE AND HANDLING

16.1 How Supplied

0.25 mg GILENYA capsules are supplied as follows:

hard gelatin capsules with an ivory opaque body and cap, with black radial imprint “FTY 0.25mg” on the cap and a black radial band on the capsule body

Bottle of 30 capsules NDC 0078-0965-15

Carton of 7 capsules containing 1 blister card of 7 capsules per blister card NDC 0078-0965-89

0.5 mg GILENYA capsules are supplied as follows:

hard gelatin capsules with a white opaque body and bright yellow cap imprinted with “FTY 0.5 mg” on the cap and 2 radial bands imprinted on the capsule body with yellow ink.

Bottle of 30 capsules NDC 0078-0607-15

Carton of 7 capsules containing 1 blister card of 7 capsules per blister card NDC 0078-0607-89

16.2 Storage and Handling

GILENYA capsules should be stored at 20 °C to 25°C (68 °F to 77°F); excursions permitted to 15°C-30°C (59°F-86°F). Protect from moisture.

17 PATIENT COUNSELING INFORMATION

Advise the patient to read the FDA-approved patient labeling (Medication Guide).

Tell patients not to discontinue GILENYA without first discussing this with the prescribing physician. Advise patients to contact their physician if they accidentally take more GILENYA than prescribed.

Cardiac Effects

Advise patients that initiation of GILENYA treatment results in a transient decrease in heart rate. Inform patients that they will need to be observed in the doctor's office or other facility for at least 6 hours after the first dose, after reinitiation if treatment is interrupted or discontinued for certain periods, and after the dosage is increased [*see Dosage and Administration (2.4), Warnings and Precautions (5.1)*].

Risk of Infections

Inform patients that they may have an increased risk of infections, some of which could be life-threatening, when taking GILENYA, and that they should contact their physician if they develop symptoms of infection. Advise patients

that the use of some vaccines should be avoided during treatment with GILENYA and for 2 months after discontinuation. Recommend to patients that they delay treatment with GILENYA until after VZV vaccination if they have not had chickenpox or a previous VZV vaccination. Inform patients that prior or concomitant use of drugs that suppress the immune system may increase the risk of infection [see *Warnings and Precautions (5.2)*].

Progressive Multifocal Leukoencephalopathy

Inform patients that cases of progressive multifocal leukoencephalopathy (PML) have occurred in patients who received GILENYA. Inform the patient that PML is characterized by a progression of deficits and usually leads to death or severe disability over weeks or months. Instruct the patient of the importance of contacting their doctor if they develop any symptoms suggestive of PML. Inform the patient that typical symptoms associated with PML are diverse, progress over days to weeks, and include progressive weakness on one side of the body or clumsiness of limbs, disturbance of vision, and changes in thinking, memory, and orientation leading to confusion and personality changes [see *Warnings and Precautions (5.3)*].

Macular Edema

Advise patients that GILENYA may cause macular edema, and that they should contact their physician if they experience any changes in their vision. Inform patients with diabetes mellitus or a history of uveitis that their risk of macular edema is increased [see *Warnings and Precautions (5.4)*].

Hepatic Effects

Inform patients that GILENYA may cause liver injury. Advise patients that they should contact their physician if they have any unexplained nausea, vomiting, abdominal pain, fatigue, anorexia, or jaundice and/or dark urine [see *Warnings and Precautions (5.5)*].

Posterior Reversible Encephalopathy Syndrome

Advise patients to immediately report to their healthcare provider any symptoms involving sudden onset of severe headache, altered mental status, visual disturbances, or seizure. Inform patients that delayed treatment could lead to permanent neurological sequelae [see *Warnings and Precautions (5.6)*].

Respiratory Effects

Advise patients that they should contact their physician if they experience new onset or worsening of dyspnea [see *Warnings and Precautions (5.7)*].

Fetal Risk

- Advise pregnant women and females of reproductive potential of the potential risk to a fetus. Advise females to inform their healthcare provider of a known or suspected pregnancy [see *Warnings and Precautions (5.8) and Use in Specific Populations (8.1, 8.3)*].
- Advise female patients of reproductive potential to use effective contraception during treatment with GILENYA and for two months after the final dose [see *Use in Specific Populations (8.3)*].

Severe Increase in Disability After Stopping GILENYA

Inform patients that severe increase in disability has been reported after discontinuation of GILENYA. Advise patients to contact their physician if they develop worsening symptoms of MS following discontinuation of GILENYA [see *Warnings and Precautions (5.9)*].

Malignancies

Advise patients that basal cell carcinoma and melanoma are associated with use of GILENYA. Advise patients that any suspicious skin lesions should be promptly evaluated. Advise patients to limit exposure to sunlight and ultraviolet light by wearing protective clothing and using a sunscreen with a high protection factor. Inform patients that lymphoma has also occurred in patients receiving GILENYA [see *Warnings and Precautions (5.12)*].

Persistence of GILENYA Effects After Drug Discontinuation

Advise patients that GILENYA remains in the blood and continues to have effects, including decreased blood lymphocyte counts, for up to 2 months following the last dose [see *Warnings and Precautions (5.13)*].

Hypersensitivity Reactions

Advise patients that GILENYA may cause hypersensitivity reactions including rash, urticaria, and angioedema. Advise patients to contact their physician if they have any symptoms associated with hypersensitivity [*see Warnings and Precautions (5.14)*].

Pregnancy and Pregnancy Registry

Instruct patients that if they are pregnant or plan to become pregnant while taking GILENYA they should inform their physician. Encourage patients to enroll in the GILENYA Pregnancy Registry if they become pregnant while taking GILENYA [*see Use in Specific Populations (8.1)*].

T2019-12

MEDICATION GUIDE
GILENYA® (je-LEN-yah)
(fingolimod)
capsules

Read this Medication Guide before you start taking GILENYA and each time you get a refill. There may be new information. If you are the parent of a child who is being treated with GILENYA, the following information applies to your child. This information does not take the place of talking to your doctor about your medical condition or your treatment.

What is the most important information I should know about GILENYA?

GILENYA may cause serious side effects, including:

1. Slow heart rate (bradycardia or bradyarrhythmia) when you start taking GILENYA. GILENYA can cause your heart rate to slow down, especially after you take your first dose. You will have a test, called an electrocardiogram (ECG), to check the electrical activity of your heart before you take your first dose of GILENYA.

All adults and children will be observed by a healthcare professional for at least 6 hours after taking their first dose of GILENYA. Children should also be observed by a healthcare professional for at least 6 hours after taking their first dose of 0.5 mg of GILENYA when switching from the 0.25 mg dose.

After you take your first dose of GILENYA, and after a child takes their first dose of 0.5 mg of GILENYA when switching from the 0.25 mg dose:

- Your pulse and blood pressure should be checked every hour.
- You should be observed by a healthcare professional to see if you have any serious side effects. If your heart rate slows down too much, you may have symptoms such as:
 - dizziness
 - tiredness
 - feeling like your heart is beating slowly or skipping beats
 - chest pain
- If you have any of the symptoms of slow heart rate, they will usually happen during the first 6 hours after your first dose of GILENYA. Symptoms can happen up to 24 hours after you take your first GILENYA dose.
- 6 hours after you take your first dose of GILENYA you will have another ECG. If your ECG shows any heart problems or if your heart rate is still too low or continues to decrease, you will continue to be observed.
- If you have any serious side effects after your first dose of GILENYA, especially those that require treatment with other medicines, you will stay in the medical facility to be observed overnight. You will also be observed for any serious side effects for at least 6 hours after you take your second dose of GILENYA the next day.
- If you have certain types of heart problems, or if you are taking certain types of medicines that can affect your heart, you will be observed overnight after you take your first dose of GILENYA.

Your slow heart rate will usually return to normal within 1 month after you start taking GILENYA. Call your doctor or go to the nearest hospital emergency room right away if you have any symptoms of a slow heart rate.

If you miss 1 or more doses of GILENYA, you may need to be observed by a healthcare professional when you take your next dose. Call your doctor if you miss a dose of GILENYA. See **“How should I take GILENYA?”**

2. Pregnancy. Please consult your doctor before getting pregnant. You should avoid becoming pregnant while taking GILENYA or in the two months after you stop taking it because of the risk of harm to the baby.

3. Infections. GILENYA can increase your risk of serious infections that can be life-threatening and cause death. You should not receive **live** vaccines during treatment with GILENYA and for 2 months after you stop taking GILENYA. Talk to your doctor before you receive a vaccine during treatment and for 2 months after treatment with GILENYA. If you receive a live vaccine, you may get the infection the vaccine was meant to prevent. Vaccines may not work as well when given during treatment with GILENYA.

Human Papilloma Virus (HPV). Due to risk of HPV infection please consult your doctor for routine pap smear.

GILENYA lowers the number of white blood cells (lymphocytes) in your blood. This will usually go back to normal within 2 months of stopping treatment. Your doctor may do a blood test to check your white blood cells before you start taking GILENYA. Call your doctor right away if you have any of these symptoms of an infection during treatment with GILENYA, and for 2 months after your last dose of GILENYA:

- fever
- vomiting

- tiredness
- body aches
- chills
- nausea
- headache with fever, neck stiffness, sensitivity to light, nausea, or confusion (these may be symptoms of meningitis, an infection of the lining around your brain and spine)

4. Progressive multifocal leukoencephalopathy (PML). PML is a rare brain infection that usually leads to death or severe disability. If PML happens, it usually happens in people with weakened immune systems but has happened in people who do not have weakened immune systems. Symptoms of PML get worse over days to weeks. Call your doctor right away if you have any new or worsening symptoms of PML, that have lasted several days, including:

- weakness on 1 side of your body
- loss of coordination in your arms and legs
- decreased strength
- problems with balance
- changes in your vision
- changes in your thinking or memory
- confusion
- changes in your personality

5. A problem with your vision called macular edema. Macular edema can cause some of the same vision symptoms as a multiple sclerosis (MS) attack (optic neuritis). You may not notice any symptoms with macular edema. If macular edema happens, it usually starts in the first 3 to 4 months after you start taking GILENYA. Your doctor should test your vision before you start taking GILENYA and 3 to 4 months after you start taking GILENYA, or any time you notice vision changes during treatment with GILENYA. Your risk of macular edema is higher if you have diabetes or have had an inflammation of your eye called uveitis.

Call your doctor right away if you have any of the following:

- blurriness or shadows in the center of your vision
- a blind spot in the center of your vision
- sensitivity to light
- unusually colored (tinted) vision

What is GILENYA?

GILENYA is a prescription medicine used to treat relapsing forms of multiple sclerosis (MS), to include clinically isolated syndrome, relapsing-remitting disease, and active secondary progressive disease, in adults and children 10 years of age and older.

It is not known if GILENYA is safe and effective in children under 10 years of age.

Who should not take GILENYA?

Do not take GILENYA if you:

- have had a heart attack, unstable angina, stroke or mini-stroke (transient ischemic attack or TIA) or certain types of heart failure in the last 6 months.
- have certain types of irregular or abnormal heartbeat (arrhythmia), including patients in whom a heart finding called prolonged QT is seen on ECG before starting GILENYA.
- have a heart rhythm problem that needs treatment with certain medicines.
- are allergic to fingolimod or any of the ingredients in GILENYA. See the end of this leaflet for a complete list of ingredients in GILENYA. Symptoms of an allergic reaction may include: rash, itchy hives, or swelling of the lips, tongue or face.

Talk to your doctor before taking GILENYA if you have any of these conditions, or do not know if you have any of these conditions.

What should I tell my doctor before taking GILENYA?

Before you take GILENYA, tell your doctor about all your medical conditions, including if you had or now have:

- an irregular or abnormal heartbeat (arrhythmia).
- a history of stroke or mini-stroke.
- heart problems, including heart attack or angina.
- a history of repeated fainting (syncope).
- a fever or infection, or you are unable to fight infections due to a disease or take or have taken medicines that lower your immune system.
- recently received a vaccine or are scheduled to receive a vaccine.
- chickenpox or have received the vaccine for chickenpox. Your doctor may do a blood test for chickenpox virus. You may need to get the full course of the vaccine for chickenpox and then wait 1 month before you start taking GILENYA.
- your child has completed their vaccination schedule. Your child needs to have completed their vaccination schedule before starting treatment with GILENYA.
- eye problems, especially an inflammation of the eye called uveitis.

- diabetes.
- breathing problems, including during your sleep.
- liver problems.
- high blood pressure.
- types of skin cancer called basal cell carcinoma (BCC) or melanoma.
- are pregnant or plan to become pregnant. GILENYA may harm your unborn baby. Talk to your doctor if you are pregnant or are planning to become pregnant. Tell your doctor right away if you become pregnant while taking GILENYA or if you become pregnant within 2 months after you stop taking GILENYA.
 - You should stop taking GILENYA 2 months before trying to become pregnant.
 - If you are a female who can become pregnant, you should use effective birth control during your treatment with GILENYA and for at least 2 months after you stop taking GILENYA.

Pregnancy Registry: There is a registry for women who become pregnant during treatment with GILENYA. If you become pregnant while taking GILENYA, talk to your doctor about registering with the GILENYA Pregnancy Registry. The purpose of this registry is to collect information about your health and your baby's health.

For more information, contact the GILENYA Pregnancy Registry by calling Quintiles at 1-877-598-7237, by sending an email to gpr@quintiles.com, or go to www.gilenyapregnancyregistry.com.

- are breastfeeding or plan to breastfeed. It is not known if GILENYA passes into your breast milk. Talk to your doctor about the best way to feed your baby if you take GILENYA.

Tell your doctor about all the medicines you take or have recently taken, including prescription and over-the-counter medicines, vitamins, and herbal supplements.

Especially tell your doctor if you take medicines that affect your immune system, including corticosteroids, or have taken them in the past.

Know the medicines you take. Keep a list of your medicines with you to show your doctor and pharmacist when you get a new medicine.

Using GILENYA and other medicines together may affect each other causing serious side effects.

How should I take GILENYA?

- Adults and children will be observed by a healthcare professional for at least 6 hours after taking their first dose of GILENYA. **Children should also be observed by a healthcare professional for at least 6 hours after taking their first dose of 0.5 mg of GILENYA when switching from the 0.25 mg dose.** See **“What is the most important information I should know about GILENYA?”**
- Take GILENYA exactly as your doctor tells you to take it.
- Take GILENYA 1 time each day.
- If you take too much GILENYA, call your doctor or go to the nearest hospital emergency room right away.
- Take GILENYA with or without food.
- Do not stop taking GILENYA without talking with your doctor first.
- Call your doctor right away if you miss a dose of GILENYA. You may need to be observed by a healthcare professional for at least 6 hours when you take your next dose. If you need to be observed by a healthcare professional when you take your next dose of GILENYA you will have:
 - an ECG before you take your dose
 - hourly pulse and blood pressure measurements after you take the dose
 - an ECG 6 hours after your dose
- If you have certain types of heart problems, or if you are taking certain types of medicines that can affect your heart, you will be observed overnight by a healthcare professional in a medical facility after you take your dose of GILENYA.
- If you have serious side effects after taking a dose of GILENYA, especially those that require treatment with other medicines, you will stay in the medical facility to be observed overnight. If you were observed overnight, you will also be observed for any serious side effects for at least 6 hours after you take your second dose of GILENYA.

See **“What is the most important information I should know about GILENYA?”**

What are possible side effects of GILENYA?

GILENYA can cause serious side effects, including:

- See **“What is the most important information I should know about GILENYA?”**
- **swelling and narrowing of the blood vessels in your brain.** A condition called PRES (Posterior Reversible Encephalopathy Syndrome) has happened rarely in adults taking GILENYA. Symptoms of PRES usually get

better when you stop taking GILENYA. However, if left untreated, it may lead to a stroke. Call your doctor right away if you have any of the following symptoms:

- sudden severe headache
- sudden confusion
- sudden loss of vision or other changes in your vision
- seizure
- **liver damage.** GILENYA may cause liver damage. Your doctor should do blood tests to check your liver before you start taking GILENYA and periodically during treatment. Call your doctor right away if you have any of the following symptoms of liver damage:
 - nausea
 - vomiting
 - stomach pain
 - tiredness
 - loss of appetite
 - your skin or the whites of your eyes turn yellow
 - dark urine
- **breathing problems.** Some people who take GILENYA have shortness of breath. Call your doctor right away if you have new or worsening breathing problems.
- **severe worsening of multiple sclerosis after stopping GILENYA.**
When GILENYA is stopped, symptoms of MS can return and become worse compared to before or during treatment. Many people who have worsening of MS symptoms after stopping GILENYA do not return to the level of function that they had before stopping GILENYA. This worsening happens most often within 12 weeks after stopping GILENYA, but can happen later. Always talk to your doctor before you stop taking GILENYA for any reason. Tell your doctor if you have worsening symptoms of MS after stopping GILENYA.
- **increased blood pressure.** Your doctor should check your blood pressure during treatment with GILENYA.
- **types of skin cancer called basal cell carcinoma (BCC) and melanoma.** Tell your doctor if you have any changes in the appearance of your skin, including changes in a mole, a new darkened area on your skin, a sore that does not heal, or growths on your skin such as a bump that may be shiny, pearly white, skin-colored, or pink. Your doctor should check your skin for any changes during treatment with GILENYA. Limit the amount of time you spend in sunlight and ultraviolet (UV) light. Wear protective clothing and use a sunscreen with a high sun protection factor.
- **allergic reactions.** Call your doctor if you have symptoms of an allergic reaction, including a rash, itchy hives, or swelling of the lips, tongue or face.

The most common side effects of GILENYA include:

- headache
- abnormal liver tests
- diarrhea
- cough
- flu
- inflammation of the sinuses (sinusitis)
- back pain
- stomach-area (abdominal) pain
- pain in arms or legs

Tell your doctor if you have any side effect that bothers you or that does not go away.

These are not all of the possible side effects of GILENYA. For more information, ask your doctor or pharmacist. Call your doctor for medical advice about side effects. You may report side effects to FDA at 1-800-FDA-1088.

How should I store GILENYA?

- Store GILENYA in the original bottle or blister pack in a dry place.
- Store GILENYA at room temperature between 68°F to 77°F (20°C to 25°C).
- **Keep GILENYA and all medicines out of the reach of children.**

General information about the safe and effective use of GILENYA.

Medicines are sometimes prescribed for purposes other than those listed in a Medication Guide. Do not use GILENYA for a condition for which it was not prescribed. Do not give GILENYA to other people, even if they have the same symptoms that you have. It may harm them. This Medication Guide summarizes the most important information about GILENYA. If you would like more information, talk with your doctor. You can ask your doctor or pharmacist for information about GILENYA that is written for health professionals.

What are the ingredients in GILENYA?

0.25 mg capsules

Active ingredient: fingolimod

Inactive ingredients: mannitol, hydroxypropylcellulose, hydroxypropylbetadex, magnesium stearate, gelatin, titanium dioxide, yellow iron oxide.

0.5 mg capsules

Active ingredient: fingolimod hydrochloride

Inactive ingredients: mannitol, magnesium stearate, gelatin, titanium dioxide, yellow iron oxide.

GILENYA is a registered trademark of Novartis, AG.

Manufactured by: Novartis Pharma Stein AG Stein, Switzerland

Distributed by: Novartis Pharmaceuticals Corporation, East Hanover, New Jersey 07936

© Novartis

T2019-xx

This Medication Guide has been approved by the U.S. Food and Drug Administration.

Revised: 12 2019

This is a representation of an electronic record that was signed electronically. Following this are manifestations of any and all electronic signatures for this electronic record.

/s/

ALICE HUGHES
12/26/2019 01:52:47 PM

PRODUCT MONOGRAPH
INCLUDING PATIENT MEDICATION INFORMATION

PrIMBRUVICA®

ibrutinib

tablets 140 mg, 280 mg, 420 mg, 560 mg

capsules 140 mg

Protein Kinase Inhibitor

Janssen Inc.
19 Green Belt Drive
Toronto, Ontario
M3C 1L9

www.janssen.com/canada

Submission Control No: 233164

© 2020 Janssen Inc.
© 2020 Pharmacyclics

All trademarks used under license.

Date of Initial Approval:
November 17, 2014

Date of Revision:
September 24, 2020

Table of Contents

PART I: HEALTH PROFESSIONAL INFORMATION.....	3
SUMMARY PRODUCT INFORMATION	3
INDICATIONS AND CLINICAL USE.....	3
CONTRAINDICATIONS	4
WARNINGS AND PRECAUTIONS.....	5
ADVERSE REACTIONS.....	12
DRUG INTERACTIONS	28
DOSAGE AND ADMINISTRATION	30
OVERDOSAGE	33
ACTION AND CLINICAL PHARMACOLOGY	34
STORAGE AND STABILITY.....	39
DOSAGE FORMS, COMPOSITION AND PACKAGING	39
PART II: SCIENTIFIC INFORMATION.....	41
PHARMACEUTICAL INFORMATION.....	41
CLINICAL TRIALS.....	41
DETAILED PHARMACOLOGY	58
TOXICOLOGY	58
REFERENCES	61
PATIENT MEDICATION INFORMATION	62

PrIMBRUVICA®

ibrutinib

tablets 140 mg, 280 mg, 420 mg, 560 mg

capsules 140 mg

Protein Kinase Inhibitor

PART I: HEALTH PROFESSIONAL INFORMATION

SUMMARY PRODUCT INFORMATION

Route of Administration	Dosage Form / Strength	Clinically Relevant Nonmedicinal Ingredients
Oral	Tablet / 140 mg, 280 mg, 420 mg, 560 mg	Lactose monohydrate. <i>For a complete listing see DOSAGE FORMS, COMPOSITION AND PACKAGING section.</i>
Oral	Capsule / 140 mg	<i>For a complete listing see DOSAGE FORMS, COMPOSITION AND PACKAGING section.</i>

INDICATIONS AND CLINICAL USE

IMBRUVICA® (ibrutinib) is indicated for the treatment of patients with previously untreated active chronic lymphocytic leukemia (CLL), including those with 17p deletion.

Clinical effectiveness of IMBRUVICA® in previously untreated patients with CLL with 17p deletion is based on the benefit observed in patients with CLL with 17p deletion who have received at least one prior therapy. Clinical trial data in previously untreated patients with CLL with 17p deletion are very limited.

IMBRUVICA® (ibrutinib) is indicated in combination with obinutuzumab for the treatment of patients with previously untreated active CLL, including those with 17p deletion.

IMBRUVICA® (ibrutinib) is indicated for the treatment of patients with CLL who have received at least one prior therapy, including those with 17p deletion.

IMBRUVICA® (ibrutinib) is indicated in combination with bendamustine and rituximab for the treatment of patients with CLL who have received at least one prior therapy.

Clinical trial data with IMBRUVICA® in combination with bendamustine and rituximab in patients with CLL with 17p deletion are limited.

IMBRUVICA® (ibrutinib) is indicated for the treatment of patients with relapsed or refractory mantle cell lymphoma (MCL).

IMBRUVICA[®] (ibrutinib) is indicated for the treatment of patients with marginal zone lymphoma (MZL) who require systemic therapy and have received at least one prior anti-CD20-based therapy.

IMBRUVICA[®] (ibrutinib) is indicated for the treatment of patients with Waldenström's macroglobulinemia (WM).

Clinical effectiveness of IMBRUVICA[®] is based on response rates demonstrated in a single-arm study in patients who had received at least one prior therapy.

IMBRUVICA[®] (ibrutinib) is indicated in combination with rituximab for the treatment of patients with WM.

IMBRUVICA[®] (ibrutinib) is indicated for the treatment of patients with steroid dependent or refractory chronic graft versus host disease (cGVHD).

Geriatrics (≥65 years of age):

In studies of patients with B-cell malignancies treated with IMBRUVICA[®], approximately 65% were ≥65 years of age. No overall differences in the efficacy of IMBRUVICA[®] treatment were observed between these patients and younger patients. Grade 3 or higher adverse events, serious adverse events, adverse events leading to drug discontinuation, and fatal adverse events occurred more frequently among elderly patients treated with IMBRUVICA[®] than among younger patients (see **WARNINGS AND PRECAUTIONS, Special Populations, Geriatrics**).

A study of 42 patients with cGVHD treated with IMBRUVICA[®] did not include sufficient numbers of patients ≥65 years of age to determine whether they respond differently from younger patients.

Pediatrics (<18 years of age):

The safety and efficacy of IMBRUVICA[®] in children and adolescents have not been established; therefore, Health Canada has not authorized an indication for pediatric use (see **ACTION AND CLINICAL PHARMACOLOGY, Special Populations and Conditions**).

CONTRAINDICATIONS

IMBRUVICA[®] is contraindicated in patients who have known hypersensitivity to ibrutinib or to any ingredient in the formulation or component of the container. For a complete listing, see **DOSAGE FORMS, COMPOSITION AND PACKAGING**.

WARNINGS AND PRECAUTIONS

Serious Warnings and Precautions

IMBRUVICA[®] should only be prescribed by a qualified physician who is experienced in the use of anti-cancer agents.

- Major bleeding events, some fatal, have been reported (see **Hemorrhage**, below)
- IMBRUVICA[®] should not be used in patients with moderate or severe hepatic impairment (see **Special Populations**, below)
- Concomitant use of IMBRUVICA[®] with a strong CYP3A inhibitor should be avoided (see **Drug Interactions**)

General

Effects on Ability to Drive and Use Machines

Fatigue, dizziness and asthenia have been reported very commonly in patients taking IMBRUVICA[®] and should be considered when assessing a patient's ability to drive or operate machines.

Carcinogenesis and Mutagenesis

Second Primary Malignancies

In the pooled safety database, non-melanoma skin cancers occurred in 6% of patients treated with IMBRUVICA[®] (see **ADVERSE REACTIONS, Non-melanoma skin cancer**). Non-skin related malignancies occurred in 4% of patients in the pooled safety database. Monitor patients for the appearance of non-melanoma skin cancers.

Cardiovascular

Cardiac Arrhythmias

Patients treated with IMBRUVICA[®] reported events of atrial fibrillation (including Grade ≥ 3 events), atrial flutter, and ventricular tachyarrhythmia (including some fatal events), particularly patients with cardiac risk factors, hypertension, acute infections, and a previous history of cardiac arrhythmia (see **ADVERSE REACTIONS, Clinical Trial Adverse Reactions**).

Periodically monitor all patients clinically for cardiac arrhythmia. Patients who develop arrhythmic symptoms (e.g., palpitations, lightheadedness, syncope, chest discomfort or new onset of dyspnea) should be evaluated clinically and if indicated have an electrocardiogram (ECG) performed. Cardiac arrhythmias should be managed appropriately, and if they persist, consider the benefits and risks of IMBRUVICA[®] treatment (including a potential increase in the risk of hemorrhage with concomitant use of anticoagulant or antiplatelet agents; see **WARNINGS AND PRECAUTIONS, Hemorrhage**) and follow the dose modification guidelines (see **DOSAGE AND ADMINISTRATION**).

PR Interval Prolongation

IMBRUVICA[®] causes a dose- and concentration-dependent prolongation of the PR interval of the electrocardiogram (see **DRUG INTERACTIONS** and **ACTION AND CLINICAL PHARMACOLOGY**). Caution should be observed in patients with pre-existing conduction system abnormalities (e.g., marked first-degree AV block or second- or third-degree AV block, sinoatrial block) or a history of rhythm disturbances (e.g., tachyarrhythmias).

Hypertension

In the pooled safety database, hypertension occurred in 12% of the patients treated with IMBRUVICA[®]. Grade 3 or 4 hypertension occurred in 4.6% of patients with a median time to onset of 5.9 months (range, 0.3 to 24 months). An increase in the prevalence of hypertension has been observed over time on treatment with IMBRUVICA[®]; see **ADVERSE REACTIONS, Long-term safety** for additional information. Monitor patients for new onset hypertension or hypertension that is not adequately controlled after starting IMBRUVICA[®]. Adjust existing anti-hypertensive medications and/or initiate anti-hypertensive treatment as appropriate.

Cerebrovascular Accidents

Cases of cerebrovascular accident, transient ischemic attack, and ischemic stroke including fatalities have been reported with the use of IMBRUVICA[®], with and without concomitant atrial fibrillation and/or hypertension, although causality with ibrutinib has not been established (see **ADVERSE REACTIONS, Post-Market Adverse Drug Reactions**). Regular monitoring and appropriate treatment of conditions that can contribute to the occurrence of these events is recommended (see **WARNINGS AND PRECAUTIONS, Cardiac Arrhythmias and Hypertension**).

Drug Interactions

Concomitant use of IMBRUVICA[®] and drugs that strongly or moderately inhibit CYP3A can increase ibrutinib exposure significantly. Strong CYP3A inhibitors should be avoided (see **DRUG INTERACTIONS**). Grapefruit and Seville oranges must not be consumed during IMBRUVICA[®] treatment, as they contain moderate inhibitors of CYP3A. If a strong or moderate CYP3A inhibitor must be used, refer to the section on concomitant use of CYP3A inhibitors for IMBRUVICA[®] dosing recommendations (see **DRUG INTERACTIONS** and **DOSAGE AND ADMINISTRATION**).

Concomitant use of IMBRUVICA[®] and drugs that strongly induce CYP3A decreases ibrutinib exposure and should be avoided (see **DRUG INTERACTIONS**).

IMBRUVICA[®] may increase the exposure of drugs that undergo BCRP-mediated hepatic efflux, such as rosuvastatin. Dose reduction of these concomitant drugs may be necessary (see **DRUG INTERACTIONS**).

IMBRUVICA[®] may increase the absorption of BCRP and P-gp substrates. Therefore, narrow therapeutic range BCRP and P-gp substrates, such as methotrexate and digoxin, respectively,

should be taken at least 6 hours before or after IMBRUVICA[®] to avoid a potential interaction in the GI tract (see **DRUG INTERACTIONS**).

Endocrine and metabolism

Tumour Lysis Syndrome

Tumour lysis syndrome has been reported with IMBRUVICA[®] therapy. Patients at risk of tumour lysis syndrome are those with high tumour burden prior to treatment. Monitor patients closely and take appropriate precautions.

Gastrointestinal

Diarrhea

In the pooled safety database, diarrhea occurred in approximately 40% of the patients with B-cell malignancies treated with IMBRUVICA[®], with Grade 3 or 4 diarrhea in 3% of patients (see **ADVERSE REACTIONS**). In a study of 42 patients with cGVHD treated with IMBRUVICA[®], diarrhea occurred in 36% of patients, with Grade 3 or 4 diarrhea in 10% of patients.

To prevent dehydration, administer fluid and electrolyte replacement and antidiarrheal medications as needed. Follow IMBRUVICA[®] dose modification guidance as needed (see **DOSAGE AND ADMINISTRATION**).

Hematologic

Cytopenias

In the pooled safety database of patients treated with IMBRUVICA[®] as a single agent, treatment-emergent Grade 3 or 4 cytopenias, including neutropenia (14%), thrombocytopenia (6%) and anemia (6%) were reported (see **ADVERSE REACTIONS**). Patients should have their complete blood counts monitored monthly and their doses modified as necessary (see **DOSAGE AND ADMINISTRATION**).

Lymphocytosis

Upon initiation of IMBRUVICA[®] as a single agent in controlled CLL clinical studies, a temporary increase in lymphocyte counts ($\geq 50\%$ increase from baseline and above absolute lymphocyte count of 5000/ μL) occurred in a majority (57% to 69%) of patients; a majority (77% to 95%) of these patients achieved resolution. The median time to treatment-emergent lymphocytosis was 1 to 2 weeks, with a median time to resolution of 12 to 14 weeks. In a study of previously untreated patients with CLL receiving IMBRUVICA[®] in combination with obinutuzumab, treatment-emergent lymphocytosis occurred in 7% of patients; median time to treatment-emergent lymphocytosis was approximately 1 week, and median time to resolution was approximately 3 weeks; all of these patients achieved resolution. In a study of previously treated patients with CLL receiving IMBRUVICA[®] in combination with bendamustine and rituximab (BR), lymphocytosis occurred in 7% of patients; median time to treatment-emergent lymphocytosis was approximately 1 week, and median time to resolution was approximately 2 weeks; 95% of these patients achieved resolution.

In the MCL clinical study, lymphocytosis occurred in 35% of patients; 68% of these patients achieved resolution. The median time to treatment-emergent lymphocytosis was 1.1 weeks, with a median time to resolution of 8 weeks.

In the MZL clinical study, lymphocytosis occurred in 11% of patients; all of these patients achieved resolution. The median time to treatment-emergent lymphocytosis was 1.1 week, with a median time to resolution of 11 weeks.

Lymphocytosis was observed in less than 1% of patients with WM treated with IMBRUVICA[®].

Lymphocytosis may be a pharmacodynamic effect of the inhibition of Bruton Tyrosine Kinase (BTK)-mediated cellular homing and adhesion, and should not be considered progressive disease in the absence of other clinical findings.

Leukostasis

Isolated cases of leukostasis have been reported in patients treated with IMBRUVICA[®]. Cases were typically reported within two to three weeks of IMBRUVICA[®] initiation, and included cases of intracranial hemorrhage, lethargy, gait instability, and headache. A high number of circulating lymphocytes (>400,000/ μ L) may confer increased risk. In patients with high number of circulating lymphocytes (>400,000/ μ L), consider temporarily withholding IMBRUVICA[®] treatment, and monitor patients closely for signs of leukostasis, particularly in patients who experience a rapid increase of lymphocyte count to above 400,000/ μ L. Administer supportive care including hydration and/or cytoreduction as indicated.

Hemorrhage

In the pooled safety database, major hemorrhagic events (Grade \geq 3), including intracranial hemorrhage (subdural hematoma, cerebral hemorrhage, subarachnoid hemorrhage), gastrointestinal bleeding, hematuria, and post-procedural hemorrhage, occurred in 3% of patients. Some events were fatal. Bleeding events of any grade, including contusion, epistaxis, and petechiae, occurred in 44% of patients treated with IMBRUVICA[®], both with and without thrombocytopenia. BTK is expressed in platelets; however, the mechanism for the bleeding events is not well understood. Based on the reports of major bleeding events from the ibrutinib global safety database of clinical trials and post-marketing exposure, a numerically increased risk of bleeding was observed in patients of older age (>65 years), patients with a history of bleeding disorders, decreased baseline thrombocyte count, increased baseline lymphocyte count, and the use of anticoagulant and/or antiplatelet agents. Fatal bleeding events were due to CNS hemorrhage in most cases.

In an *in vitro* human platelet function study, ibrutinib was shown to have an inhibitory effect on collagen-induced platelet aggregation.

In clinical studies, IMBRUVICA[®]-treated patients using concomitant antiplatelet or anticoagulant agents had more minor bleeding events compared to those without these concomitant drugs. Patients were excluded from participation in IMBRUVICA[®] studies if they required warfarin or other vitamin K antagonists, or if they had a recent history of stroke or intracranial hemorrhage. Patients with congenital bleeding diathesis have not been studied.

Warfarin or other vitamin K antagonists should not be administered concomitantly with IMBRUVICA[®]. IMBRUVICA[®] should be used with caution in patients requiring other anticoagulants or medications that inhibit platelet function. If therapeutic anticoagulation is required, consider temporarily withholding IMBRUVICA[®] treatment until stable anticoagulation is achieved. Supplements that may have an inhibitory effect on platelet aggregation, such as fish oil, flaxseed, and vitamin E preparations, should be avoided.

IMBRUVICA[®] should be held at least 3 to 7 days pre and post-surgery, and reinitiated at the discretion of the physician, depending upon the type of surgery and the risk of bleeding.

Immune

Infections

In the pooled safety database, infections (including sepsis, bacterial, viral, or fungal infections) occurred in approximately 70% of patients with B-cell malignancies treated with IMBRUVICA[®], with Grade 3 or 4 infections in approximately 25% of patients, and fatal infections in 2% of patients. In a study of 42 patients with cGVHD treated with IMBRUVICA[®], infections occurred in 69% of patients, with Grade 3 or 4 infections in 31% of patients, and fatal infections in 5% of patients.

Most patients reporting infections, including those with fatal infections, also had neutropenia. Patients should be monitored for fever, neutropenia, and infection, and appropriate anti-infective therapy should be instituted as indicated. Consider prophylaxis according to standard of care in patients who are at increased risk for opportunistic infections. As ibrutinib exposure may be affected by CYP3A inducers and inhibitors, follow IMBRUVICA[®] dose modification guidance as needed during anti-infective treatment (see **DRUG INTERACTIONS** and **DOSAGE AND ADMINISTRATION**).

Progressive multifocal leukoencephalopathy

Cases of progressive multifocal leukoencephalopathy (PML) have occurred in patients treated with IMBRUVICA[®], although causality has not been established. Patients should be monitored for symptoms (chills, weakness, confusion), and appropriate therapy should be instituted as indicated.

Hepatitis B virus reactivation

Cases of hepatitis B reactivation have occurred in patients treated with IMBRUVICA[®], although causality has not been established. Patients should be monitored for signs and symptoms (jaundice, abdominal pain, weakness, fatigue, nausea and vomiting), and appropriate therapy should be instituted as indicated.

Interstitial Lung Disease

Cases of interstitial lung disease (ILD), including cases confirmed by biopsy, have been reported in patients treated with IMBRUVICA[®] (see **ADVERSE REACTIONS**, **Overview** and **Post-Market Adverse Drug Reactions**).

Monitor patients for pulmonary symptoms indicative of ILD. Advise patients to report promptly any new or worsening respiratory symptoms. If symptoms develop, interrupt IMBRUVICA[®], manage appropriately, consider the risks and benefits of IMBRUVICA[®] before resuming treatment, and follow the dose modification guidance (see **DOSAGE AND ADMINISTRATION**). If ILD is confirmed, discontinue IMBRUVICA[®]. In confirmed cases of ILD, recovery with medical management and discontinuation of IMBRUVICA[®] has been reported.

Peri-Operative Considerations

IMBRUVICA[®] should be held at least 3 to 7 days pre and post-surgery depending on the type of surgery and the risk of bleeding (see **WARNINGS AND PRECAUTIONS, Hemorrhage**).

Sexual Function/Reproduction

No human data on the effects of IMBRUVICA[®] on fertility are available. No effects of ibrutinib on fertility or reproductive capacities were observed in male or female rats (see **TOXICOLOGY, Reproductive and Developmental Toxicity**).

It is not known whether ibrutinib or its metabolites are present in semen. Men should be advised to not father a child or donate sperm while receiving IMBRUVICA[®], and for 3 months following completion of treatment.

Special Populations

Pregnant Women

There are no adequate and well controlled studies of IMBRUVICA[®] in pregnant women. In studies with pregnant rats, ibrutinib was associated with increased post-implantation loss, increased visceral malformations (heart and major vessels), and decreased fetal weights. In studies with pregnant rabbits, ibrutinib was associated with increased post-implantation loss and skeletal malformations (fused sternebrae) (see **TOXICOLOGY, Reproductive and Developmental Toxicity**). Based on these findings, IMBRUVICA[®] may cause fetal harm when administered to pregnant women.

IMBRUVICA[®] should not be used during pregnancy. Women of child bearing potential must use highly effective contraceptive measures while taking IMBRUVICA[®] and for at least 3 months after ending treatment. Women who use hormonal methods of birth control must add a barrier method. If IMBRUVICA[®] is used during pregnancy or if the patient becomes pregnant while taking IMBRUVICA[®], the patient should be apprised of the potential hazard to a fetus.

It is not known whether ibrutinib or its metabolites are present in semen. Male patients should use a condom if engaging in sexual activity with a pregnant woman while receiving IMBRUVICA[®] and for 3 months after treatment has stopped.

Nursing Women

It is not known whether ibrutinib or its metabolites are excreted in human milk. Because many drugs are excreted in human milk and because of the potential for serious adverse reactions to

IMBRUVICA[®] in nursing infants, breastfeeding should be discontinued during IMBRUVICA[®] treatment.

Pediatrics (<18 years of age)

The safety and efficacy of IMBRUVICA[®] in children and adolescents have not been established; therefore, Health Canada has not authorized an indication for pediatric use (see **ACTION AND CLINICAL PHARMACOLOGY, Special Populations and Conditions**).

Geriatrics (≥65 years of age)

In patients with B-cell malignancies, no overall differences in the efficacy of IMBRUVICA[®] treatment were observed between patients ≥65 years of age and younger patients. Patients ≥65 years of age had higher steady-state systemic exposures of ibrutinib and the dihydrodiol metabolite compared to patients <65 years of age (see **ACTION AND CLINICAL PHARMACOLOGY, Special Populations and Conditions**).

In the pooled safety database, approximately 65% of patients with B-cell malignancies were ≥65 years of age. Grade 3 or higher adverse events occurred more frequently among elderly patients treated with IMBRUVICA[®] (73% of patients age ≥65 versus 65% of younger patients). Grade ≥3 serious adverse events were also reported more frequently in elderly patients than in younger patients (46% versus 35%, respectively), as were adverse events leading to drug discontinuation (13% versus 9%, respectively) and fatal adverse events (7% versus 4%, respectively). Events reported more frequently in patients ≥65 years compared to younger patients included thrombocytopenia, pneumonia, hypertension, urinary tract infection, and atrial fibrillation.

A study of 42 patients with cGVHD treated with IMBRUVICA[®] did not include sufficient numbers of patients ≥65 years of age to determine whether they respond differently from younger patients.

Hepatic Impairment

Ibrutinib is metabolized in the liver. Patients with serum aspartate transaminase (AST/SGOT) or alanine transaminase (ALT/SGPT) ≥3.0x upper limit of normal (ULN) were excluded from IMBRUVICA[®] clinical trials. In a study in patients with hepatic impairment, data showed a significant increase in ibrutinib exposure (see **ACTION AND CLINICAL PHARMACOLOGY, Special Populations and Conditions**). As hepatic impairment can lead to coagulopathy, the risk of bleeding associated with IMBRUVICA[®] may be increased in patients with moderate or severe hepatic impairment. IMBRUVICA[®] should not be used in patients with moderate (Child-Pugh class B) or severe hepatic impairment (Child-Pugh class C). Pharmacokinetic data showed comparable exposures of the unbound ibrutinib in patients with mild hepatic impairment (Child-Pugh class A) administered a 140 mg dose and patients without hepatic impairment administered a 420 mg daily dose. If the benefit is considered to outweigh the risk in a patient with mild hepatic impairment, a dose reduction to 140 mg should be considered. Monitor patients for signs of toxicity (see **DOSAGE AND ADMINISTRATION**).

Renal Impairment

Ibrutinib has minimal renal clearance. Clinical pharmacokinetic studies have not been conducted in patients with renal impairment. Patients with mild or moderate renal impairment (creatinine clearance >30 mL/min) were treated in clinical studies without adjustment of the starting dose. Hydration should be maintained and serum creatinine levels monitored periodically. There are no data in patients with severe renal impairment or patients on dialysis (see **ACTION AND CLINICAL PHARMACOLOGY, Pharmacokinetics**).

Monitoring and Laboratory Tests

Patients should have their baseline renal function and hepatic status, and coagulation status measured prior to IMBRUVICA[®] initiation. Patients with cardiac risk factors or a history of atrial fibrillation, or with acute infections should have their baseline ECG assessed prior to IMBRUVICA[®] initiation.

Patients treated with IMBRUVICA[®] should be monitored for symptoms of atrial fibrillation, infection, hepatitis B reactivation, fever, tumour lysis syndrome, new onset hypertension or hypertension that is not adequately controlled, and have their complete blood counts monitored monthly. Patients with renal impairment should have their serum creatinine levels monitored periodically.

ADVERSE REACTIONS

Overview

The safety of IMBRUVICA[®] has been assessed in completed clinical development studies as well as in the post-marketing setting.

Chronic Lymphocytic Leukemia (CLL) studies

The data described below reflect exposure to IMBRUVICA[®] in four controlled, randomized clinical studies (Study PCYC-1115-CA, Study PCYC-1130-CA, Study PCYC-1112-CA, and Study CLL3001) and one single-arm study (Study PCYC-1102-CA) that included patients with CLL treated with 420 mg IMBRUVICA[®] daily, as a single agent, in combination with obinutuzumab, or in combination with bendamustine and rituximab.

The most commonly occurring adverse reactions in the studies ($\geq 20\%$) were neutropenia, diarrhea, rash, musculoskeletal pain, bruising, nausea, thrombocytopenia, fatigue, pyrexia, hemorrhage, cough, and anemia. The most common Grade 3/4 adverse reactions ($\geq 5\%$) were neutropenia, thrombocytopenia, pneumonia, and febrile neutropenia.

Approximately 7% of patients receiving IMBRUVICA[®] in the studies discontinued treatment due to adverse reactions. The most frequent adverse reactions leading to treatment discontinuation included pneumonia, hemorrhage, atrial fibrillation, neutropenia, and rash. Adverse reactions leading to dose reduction occurred in approximately 7% of patients.

Mantle Cell Lymphoma (MCL) study

The data described below reflect exposure to IMBRUVICA[®] in a single-arm clinical study (Study PCYC-1104-CA) that included patients with relapsed or refractory MCL treated with 560 mg IMBRUVICA[®] daily.

The most commonly occurring adverse reactions ($\geq 20\%$) were diarrhea, fatigue, nausea, dyspnea, constipation, upper respiratory tract infection, oedema peripheral, vomiting, decreased appetite, cough and thrombocytopenia. The most common Grade 3/4 adverse reactions ($\geq 5\%$) were neutropenia, thrombocytopenia, anemia, pneumonia, atrial fibrillation, abdominal pain, and diarrhea.

Approximately 11% of patients receiving IMBRUVICA[®] in the Study PCYC-1104-CA discontinued treatment due to adverse reactions. The most frequent adverse reaction leading to treatment discontinuation was subdural hematoma (1.8%). Adverse reactions leading to dose reduction occurred in approximately 16% of patients.

Marginal zone lymphoma (MZL) study

The data described below reflect exposure to IMBRUVICA[®] in a single-arm clinical study (Study PCYC-1121-CA) that included 63 patients with MZL who had received at least one prior line of systemic therapy.

The most commonly occurring adverse reactions ($\geq 20\%$) were fatigue, diarrhea, bruising, musculoskeletal pain, anemia, hemorrhage, rash, nausea, thrombocytopenia, arthralgia, edema peripheral, cough, dyspnea and upper respiratory tract infection (see Table 11). The most commonly occurring Grade 3/4 adverse reactions ($\geq 5\%$) were anemia, pneumonia, and fatigue.

Thirteen percent of patients discontinued treatment due to adverse reactions. The most frequent adverse reactions leading to treatment discontinuation were diarrhea, ILD (i.e. pneumonitis, eosinophilic pneumonia), and rash. Adverse reactions leading to dose reduction occurred in approximately 10% of patients.

Waldenström's Macroglobulinemia (WM) studies

The data described below reflect exposure to 420 mg IMBRUVICA[®] daily in patients with WM, as a single agent or in combination with rituximab in an open-label, single-arm clinical study (Study PCYC-1118E) and a randomized, double-blind, controlled phase 3 study with a non-randomized substudy arm (Study PCYC-1127-CA).

The most commonly occurring adverse reactions in the WM studies ($\geq 20\%$) were hemorrhage (e.g., bruising), diarrhea, musculoskeletal pain, rash, nausea, and neutropenia. The most common Grade 3/4 adverse reactions ($\geq 5\%$) were neutropenia, pneumonia, hypertension, atrial fibrillation, and thrombocytopenia.

Five percent of patients receiving IMBRUVICA[®] in Studies PCYC-1118E and PCYC-1127-CA discontinued IMBRUVICA[®] treatment due to adverse reactions. Adverse reactions leading to IMBRUVICA[®] dose reduction occurred in 14% of patients.

Chronic graft versus host disease (cGVHD) study

The data described below reflect exposure to IMBRUVICA[®] in an open-label clinical study (Study PCYC-1129-CA) that included patients with cGVHD who failed first line corticosteroid therapy and required additional therapy.

The most commonly occurring adverse reactions in the cGVHD study ($\geq 20\%$) were fatigue, bruising, diarrhea, stomatitis, muscle spasms, nausea, hemorrhage, and pneumonia. Grade 3/4 adverse reactions were experienced by 45% of patients. The most common Grade 3/4 adverse reactions ($\geq 5\%$) were fatigue, diarrhea, pneumonia, sepsis, and hypokalemia. Atrial fibrillation occurred in one patient (2%), which was Grade 3. Serious adverse reactions occurred in 52% of patients. The most common serious adverse reactions (2 or more patients) were pneumonia, sepsis (septic shock), cellulitis, headache, and pyrexia. There were two fatal events, one case of pneumonia and one case of pulmonary aspergillosis.

Adverse reactions leading to treatment discontinuation occurred in 24% of patients, the most common being fatigue and pneumonia. Adverse reactions leading to dose reduction occurred in 26% of patients.

Non-melanoma skin cancer

The incidence of non-melanoma skin cancer in IMBRUVICA[®]-treated patients was approximately 6% across the following studies: PCYC-1102-CA, PCYC-1104-CA, PCYC-1112-CA, PCYC-1118E, PCYC-1115-CA, CLL3001, PCYC-1129-CA, PCYC-1121-CA, PCYC-1127-CA, and PCYC-1130-CA.

Interstitial Lung Disease

The incidence of interstitial lung disease in IMBRUVICA[®]-treated patients was 2% (0.3% were considered as Grade 3 or 4 in severity and a single fatal case (0.1%) was reported) across pivotal phase 2 and 3 studies in patients with CLL, MCL, MZL, WM, and cGVHD.

Atrial fibrillation

In the randomized clinical trials in patients with CLL, atrial fibrillation was reported more frequently in patients treated with 420 mg daily IMBRUVICA[®] (7%; Grade 3+4, 3%) than in the comparator arms (1%; Grade 3+4, 0.3%).

In a single-arm phase 2 clinical trial in patients with MCL (Study PCYC-1104), atrial fibrillation was reported in 10% (Grade 3+4, 6%) of patients treated with 560 mg daily IMBRUVICA[®].

In the randomized clinical trial in patients with WM (Study PCYC-1127-CA), atrial fibrillation was reported more frequently in patients treated with 420 mg daily IMBRUVICA[®] in combination with rituximab (15%; Grade 3+4, 12%) than in the placebo + rituximab comparator arm (3%; Grade 3+4, 1%). In the single arm trials in patients with WM (Study PCYC1118E and the single-agent therapy arm of Study PCYC-1127-CA), atrial fibrillation was reported in 5% (Grade 3+4, 2%) of patients treated with 420 mg daily IMBRUVICA[®] as a single agent.

Long-term safety

Long-term safety data for patients treated with IMBRUVICA[®] indicate that there is generally no cumulative or unique late-onset toxicity with continued IMBRUVICA[®] treatment. The long-term safety data is based on studies in patients with CLL/SLL (n=807) treated with IMBRUVICA[®] as a single agent or in combination for a median of 45 months (range, 0.2 to 86.7 months) with 70% and 40% of patients receiving treatment for more than 2 years and 4 years, respectively, and studies in patients with MCL (n=370) treated with IMBRUVICA[®] for a median of 11 months (range, 0.0 to 75.7 months) with 31% and 14% of patients receiving treatment for more than 2 years and 4 years, respectively. The prevalence of hypertension increased: year 0-1, 10% (Grade \geq 3, 4%); year 1-2, 13% (Grade \geq 3, 6%); year 2-3, 19% (Grade \geq 3, 8%); and year 3-4, 19% (Grade \geq 3, 8%); the incidence for the 4-year period was 19% (Grade \geq 3, 10%).

Clinical Trial Adverse Drug Reactions

Because clinical trials are conducted under very specific conditions the adverse drug reaction rates observed in the clinical trials may not reflect the rates observed in practice and should not be compared to the rates in the clinical trials of another drug. Adverse drug reaction information from clinical trials is useful for identifying drug-related adverse events and for approximating rates.

Adverse reactions presented in this section are adverse events that were considered to be reasonably associated with the use of ibrutinib based on the comprehensive assessment of the available adverse event information. A causal relationship with ibrutinib cannot be reliably established in individual cases.

Previously Untreated Chronic Lymphocytic Leukemia

Single-agent therapy

Adverse reactions described in Table 1 below reflect exposure to IMBRUVICA[®] with a median duration of 17.4 months, which is approximately 2.5 times the median exposure to chlorambucil of 7.1 months in Study PCYC-1115-CA. Hematologic laboratory abnormalities are described in Table 2.

Table 1: Adverse reactions[†] reported from Study PCYC-1115-CA

System Organ Class Adverse reaction	IMBRUVICA [®] (N=135)		Chlorambucil (N=132)	
	All Grades (%)	Grade 3 or 4 (%)	All Grades (%)	Grade 3 or 4 (%)
Cardiac disorders				
Atrial fibrillation	6	1	1	0
Eye Disorders				
Dry eye	17	0	5	0
Lacrimation increased	13	0	6	0
Vision blurred	13	0	8	0
Visual acuity reduced	11	0	2	0
Gastrointestinal disorders				
Diarrhea	42	4	17	0

System Organ Class Adverse reaction	IMBRUVICA® (N=135)		Chlorambucil (N=132)	
	All Grades (%)	Grade 3 or 4 (%)	All Grades (%)	Grade 3 or 4 (%)
Stomatitis*	14	1	4	1
Dyspepsia	11	0	2	0
General disorders and administration site conditions				
Peripheral edema	19	1	9	0
Infections and infestations				
Skin infection*	15	2	3	1
Pneumonia*	14	8	7	4
Musculoskeletal and connective tissue disorders				
Musculoskeletal pain*	36	4	20	0
Arthralgia	16	1	7	1
Muscle spasms	11	0	5	0
Metabolism and nutrition disorders				
Hyponatremia	7	3	1	0
Neoplasms benign, malignant, and unspecified (including cysts and polyps)				
Basal cell carcinoma	9	1	2	0
Respiratory, thoracic and mediastinal disorders				
Cough	22	0	15	0
Skin and subcutaneous tissue disorders				
Rash*	21	4	12	2
Bruising*	19	0	7	0
Vascular Disorders				
Hypertension*	14	4	1	0

* Includes multiple adverse reaction terms

† Adverse reactions meeting the following criteria are presented: ≥10% incidence in the IMBRUVICA® arm and ≥5% higher incidence compared to the chlorambucil arm, or serious reactions reported in ≥2% of patients in the IMBRUVICA® arm and >2% higher incidence compared to the chlorambucil arm, or biological plausibility. Patients with multiple events for a given adverse reaction term are counted once only for each adverse reaction term. Events are sorted by system organ class and by decreasing frequency of adverse reaction term in the IMBRUVICA® arm.

Less common adverse events reported in patients treated with IMBRUVICA® included:

Major hemorrhage events (4%): cerebral hemorrhage (<1%), hyphema (<1%), post-procedural hemorrhage (<1%), subarachnoid hemorrhage (<1%), subdural hematoma (<1%), traumatic hematoma (<1%), vitreous hemorrhage (<1%);

Non-melanoma skin cancer: squamous cell carcinoma (4%);

Eye disorders: eye pain (6%), vitreous floaters (6%), cataract (5%), blindness unilateral (1%).

Abnormal Hematologic and Clinical Chemistry Findings (Previously Untreated CLL, single-agent therapy)

Table 2: Hematologic laboratory abnormalities (per IWCLL criteria) from Study PCYC-1115-CA

Laboratory Parameter	IMBRUVICA® N=135		Chlorambucil N=132	
	All Grades (%)	Grades 3 or 4 (%)	All Grades (%)	Grades 3 or 4 (%)
Hemoglobin decreased ^a	36	0	39	2
Neutrophils decreased ^b	55	28	67	31
Platelets decreased ^c	47	7	58	14

^a Grade 1: decreased $\geq 10.5\%$ to $< 24.5\%$ and $<$ lower limit of normal (LLN); Grade 2: decreased $\geq 24.5\%$ to $< 49.5\%$ and $<$ LLN; Grade 3: decreased $\geq 49.5\%$ to $< 74.5\%$ and $<$ LLN; Grade 4: decreased $\geq 74.5\%$ and $<$ LLN.

^b Units= $\times 10^9/L$; Grade 1: ≥ 1.5 to < 2.0 ; Grade 2: ≥ 1.0 to < 1.5 ; Grade 3: ≥ 0.5 to < 1.0 ; Grade 4: < 0.5 .

^c Grade 1: decreased $\geq 10.5\%$ to $< 24.5\%$ and $<$ LLN; Grade 2: decreased $\geq 24.5\%$ to $< 49.5\%$ and $<$ LLN; Grade 3: decreased $\geq 49.5\%$ to $< 74.5\%$ and $<$ LLN; Grade 4: decreased $\geq 74.5\%$ and $<$ LLN, or $< 20 \times 10^9/L$.

Combination therapy

Adverse reactions described below in Table 3 reflect exposure to IMBRUVICA® + obinutuzumab with a median duration of 29.3 months, which is approximately 5.8 times the median exposure to chlorambucil + obinutuzumab of 5.1 months in Study PCYC-1130-CA. Hematologic laboratory abnormalities are described in Table 4.

Table 3: Adverse reactions^a reported from Study PCYC-1130-CA

System Organ Class Adverse Reaction	IMBRUVICA® + Obinutuzumab (N=113)		Chlorambucil + Obinutuzumab (N=115)	
	All Grades (%)	Grade 3 or 4 (%)	All Grades (%)	Grade 3 or 4 (%)
Blood and lymphatic system disorders				
Neutropenia*	48	39	64	48
Thrombocytopenia*	36	19	28	11
Anemia	17	4	25	8
Cardiac disorders				
Atrial fibrillation	12	5	0	0
Gastrointestinal disorders				
Diarrhea	34	3	10	0
Constipation	16	0	12	1
Nausea	12	0	30	0
General disorders and administration site conditions				
Pyrexia	19	2	26	1
Fatigue	18	0	17	2
Peripheral edema	12	0	7	0
Infections and infestations				
Pneumonia*	16	9	9	3
Upper respiratory tract infection	14	1	6	0
Skin infection*	13	1	3	0
Urinary tract infection	12	3	7	1
Nasopharyngitis	12	0	3	0
Conjunctivitis	11	0	2	0

System Organ Class Adverse Reaction	IMBRUVICA [®] + Obinutuzumab (N=113)		Chlorambucil + Obinutuzumab (N=115)	
	All Grades (%)	Grade 3 or 4 (%)	All Grades (%)	Grade 3 or 4 (%)
Injury, Poisoning and Procedural Complications				
Infusion related reaction	25	2	58	8
Metabolism and nutrition disorders				
Hyperuricemia	13	1	0	0
Musculoskeletal and connective tissue disorders				
Musculoskeletal pain*	33	1	23	3
Arthralgia	22	1	10	0
Muscle spasms	13	0	6	0
Psychiatric disorders				
Insomnia	12	0	4	0
Respiratory, thoracic and mediastinal disorders				
Cough	27	1	12	0
Skin and subcutaneous tissue disorders				
Rash*	36	3	11	0
Bruising*	32	3	3	0
Vascular disorders				
Hemorrhage*	25	1	9	0
Hypertension*	17	4	4	3

^a Occurring at ≥10% incidence in the IMBRUVICA[®] + obinutuzumab arm.

* Includes multiple adverse reaction terms

Events are sorted by system organ class and by decreasing frequency of adverse reaction term in the IMBRUVICA[®] + obinutuzumab arm.

Less common adverse events reported in patients treated with IMBRUVICA[®] + obinutuzumab included:

Cardiac Disorders: cardiac arrhythmias [19.5%: including palpitations (6.2%), bradycardia (4.4%), tachycardia (2.7%), syncope (1.8%)]

Eye Disorders: cataract (8.8%)

Abnormal Hematologic and Clinical Chemistry Findings (Previously Untreated CLL, combination therapy)

Table 4: Hematologic laboratory abnormalities (per IWCLL criteria) from Study PCYC-1130-CA

Laboratory Parameter	IMBRUVICA [®] + Obinutuzumab (N=113)		Chlorambucil + Obinutuzumab (N=115)	
	All Grades (%)	Grades 3 or 4 (%)	All Grades (%)	Grades 3 or 4 (%)
Hemoglobin decreased ^a	27	0	34	0
Neutrophils decreased ^b	60	40	74	39
Platelets decreased ^c	62	22	57	17

^a Grade 1: decreased ≥10.5% to <24.5% and <lower limit of normal (LLN); Grade 2: decreased ≥24.5% to <49.5% and <LLN; Grade 3: decreased ≥49.5% to <74.5% and <LLN; Grade 4: decreased ≥74.5% and <LLN.

^b Units=x10⁹/L; Grade 1: ≥1.5 to <2.0; Grade 2: ≥1.0 to <1.5; Grade 3: ≥0.5 to <1.0; Grade 4: <0.5.

^c Grade 1: decreased ≥10.5% to <24.5% and <LLN; Grade 2: decreased ≥24.5% to <49.5% and <LLN; Grade 3: decreased ≥49.5% to <74.5% and <LLN; Grade 4: decreased ≥74.5% and <LLN, or <20x10⁹/L.

Previously Treated Chronic Lymphocytic Leukemia

Single-agent therapy

Adverse reactions described in Table 5 below reflect exposure to IMBRUVICA[®] with a median duration of 8.6 months and exposure to ofatumumab with a median duration of 5.3 months in Study PCYC-1112-CA. Hematologic laboratory abnormalities are described in Table 6.

Table 5: Adverse reactions[†] reported from Study PCYC-1112-CA

System Organ Class Adverse reaction	IMBRUVICA [®] (N=195)		Ofatumumab (N=191)	
	All Grades (%)	Grade 3 or 4 (%)	All Grades (%)	Grade 3 or 4 (%)
Blood and lymphatic system disorders				
Anemia	23	5	17	8
Neutropenia	22	16	15	14
Thrombocytopenia	17	6	12	4
Lymphocytosis	4	2	3	1
Leukocytosis	4	3	1	0
Febrile neutropenia	2	2	3	3
Cardiac disorders				
Atrial fibrillation	5	3	1	0
Eye disorders				
Vision blurred	10	0	3	0
Gastrointestinal disorders				
Diarrhea	48	4	18	2
Nausea	26	2	18	0
Stomatitis*	17	1	6	1
Constipation	15	0	9	0
Vomiting	14	0	6	1
General disorders and administration site conditions				
Pyrexia	24	2	15	1
Infections and infestations				
Upper respiratory tract infection	16	1	10	2
Pneumonia*	15	10	13	9
Sinusitis*	11	1	6	0
Urinary tract infection	10	4	5	1
Skin infection*	7	2	3	1
Sepsis*	4	2	4	3
Injury, poisoning and procedural complications				
Subdural hematoma	1	0	0	0
Musculoskeletal and connective tissue disorders				
Musculoskeletal pain*	28	2	18	1
Arthralgia	17	1	7	0
Nervous system disorders				
Headache	14	1	6	0

System Organ Class Adverse reaction	IMBRUVICA® (N=195)		Ofatumumab (N=191)	
	All Grades (%)	Grade 3 or 4 (%)	All Grades (%)	Grade 3 or 4 (%)
Dizziness	11	0	5	0
Respiratory, thoracic and mediastinal disorders				
Epistaxis	9	0	3	1
Skin and subcutaneous tissue disorders				
Rash*	24	3	13	0
Bruising*	21	0	4	0
Petechiae	14	0	1	0

* Includes multiple adverse reaction terms.

† Adverse reactions occurring at ≥10% incidence and ≥5% greater in the IMBRUVICA® arm when compared to the ofatumumab arm or serious adverse reactions ≥2% incidence and ≥2% greater in the IMBRUVICA® arm when compared to the ofatumumab arm or that are biologically plausible are presented. Patients with multiple events for a given adverse reaction term are counted once only for each adverse reaction term. Events are sorted by system organ class and by decreasing frequency of adverse reaction term in the IMBRUVICA® arm.

Isolated cases of leukostasis have been observed (see **WARNINGS AND PRECAUTIONS, Hematologic**).

Long-term safety data for patients treated with IMBRUVICA® in Study PCYC-1112-CA indicate a generally consistent safety profile with no cumulative or late-onset toxicity after a median duration of exposure of 18.3 months compared with 8.6 months. The prevalence rate of hypertension increased from the first exposure period analyzed (>0-1 year: all grades, 8%; Grade 3, 4%) to the second exposure period (>1-2 years: all grades, 14%; Grade 3, 8%); no Grade 4 or 5 events were observed.

Abnormal Hematologic and Clinical Chemistry Findings (Previously Treated CLL, single agent therapy)

Table 6: Hematologic laboratory abnormalities (per IWCLL criteria) from Study PCYC-1112-CA

Laboratory Parameter	IMBRUVICA® N=195		Ofatumumab N=191	
	All Grades (%)	Grades 3 or 4 (%)	All Grades (%)	Grades 3 or 4 (%)
Hemoglobin decreased ^a	36	0	21	0
Neutrophils decreased ^b	51	23	57	26
Platelets decreased ^c	52	5	45	10

^a Grade 1: decreased ≥10.5% to <24.5% and <lower limit of normal (LLN); Grade 2: decreased ≥24.5% to <49.5% and <LLN; Grade 3: decreased ≥49.5% to <74.5% and <LLN; Grade 4: decreased ≥74.5% and <LLN.

^b Units= $\times 10^9/L$; Grade 1: ≥1.5 to <2.0; Grade 2: ≥1.0 to <1.5; Grade 3: ≥0.5 to <1.0; Grade 4: <0.5.

^c Grade 1: decreased ≥10.5% to <24.5% and <LLN; Grade 2: decreased ≥24.5% to <49.5% and <LLN; Grade 3: decreased ≥49.5% to <74.5% and <LLN; Grade 4: decreased ≥74.5% and <LLN, or <20 $\times 10^9/L$.

Combination therapy

Adverse reactions described in Table 7 below reflect exposure to IMBRUVICA® in combination with bendamustine and rituximab (BR) with a median duration of 14.7 months and exposure to placebo in combination with BR with a median duration of 12.8 months in Study CLL3001. Bendamustine and rituximab were administered for up to 6 cycles, while IMBRUVICA® or

placebo were administered daily for the duration of the study. Hematologic laboratory abnormalities are described in Table 8.

Table 7: Adverse reactions[†] reported from Study CLL3001

System Organ Class Adverse Reaction Term	IMBRUVICA [®] +BR (N=287)		Placebo+BR (N=287)	
	All Grades %	Grade 3 or 4 %	All Grades %	Grade 3 or 4 %
Blood and lymphatic system disorders				
Thrombocytopenia	31	15	24	15
Cardiac disorders				
Atrial fibrillation	7	3	2	1
Vascular disorders				
Hypertension*	10	5	5	2
Gastrointestinal disorders				
Diarrhea	36	2	23	1
Skin and subcutaneous tissue disorders				
Rash*	24	3	18	1
Bruising*	18	<1	6	0
Musculoskeletal and connective tissue disorders				
Musculoskeletal pain*	29	2	20	0
Muscle spasms	12	<1	5	0

Events are sorted by system organ class and by decreasing frequency of adverse reaction term in the IMBRUVICA[®]+BR arm.

[†] Adverse reactions meeting the following criteria are presented: TEAE with $\geq 10\%$ incidence and $\geq 5\%$ greater in the IMBRUVICA[®]+BR arm when compared to the placebo+BR arm; Serious TEAE with $\geq 2\%$ incidence and $\geq 2\%$ greater in the IMBRUVICA[®]+BR arm when compared to the placebo+BR arm.

* Includes multiple adverse reaction terms

<1 used for frequency below 0.5%

Abnormal Hematologic and Clinical Chemistry Findings (CLL, combination therapy)

Table 8: Hematologic laboratory abnormalities (per IWCLL criteria) from Study CLL3001

Laboratory Parameter	IMBRUVICA [®] +BR (N=287)		Placebo+BR (N=287)	
	All Grades (%)	Grades 3 or 4 (%)	All Grades (%)	Grades 3 or 4 (%)
Hemoglobin decreased ^a	54	2	61	3
Neutrophils decreased ^b	90	72	88	70
Platelets decreased ^c	83	33	82	27

^a Grade 1: decreased $\geq 10.5\%$ to $<24.5\%$ and $<$ lower limit of normal (LLN); Grade 2: decreased $\geq 24.5\%$ to $<49.5\%$ and $<$ LLN; Grade 3: decreased $\geq 49.5\%$ to $<74.5\%$ and $<$ LLN; Grade 4: decreased $\geq 74.5\%$ and $<$ LLN.

^b Units= $\times 10^9/L$; Grade 1: ≥ 1.5 to <2.0 ; Grade 2: ≥ 1.0 to <1.5 ; Grade 3: ≥ 0.5 to <1.0 ; Grade 4: <0.5 .

^c Grade 1: decreased $\geq 10.5\%$ to $<24.5\%$ and $<$ LLN; Grade 2: decreased $\geq 24.5\%$ to $<49.5\%$ and $<$ LLN; Grade 3: decreased $\geq 49.5\%$ to $<74.5\%$ and $<$ LLN; Grade 4: decreased $\geq 74.5\%$ and $<$ LLN, or $<20 \times 10^9/L$.

Mantle Cell Lymphoma

Adverse reactions described in Table 9 below reflect exposure to IMBRUVICA[®] (560 mg daily) with a median treatment duration of 8.3 months in Study PCYC-1104-CA. Patients received

IMBRUVICA[®] until disease progression or unacceptable toxicity. Hematologic laboratory abnormalities are described in Table 10.

Table 9: Adverse reactions[†] reported from Study PCYC-1104-CA (N=111)

System Organ Class	Adverse Reaction	Frequency	
		All grades (%)	Grades 3 or 4 (%)
Blood and lymphatic system disorders	Thrombocytopenia	22	13
	Neutropenia	19	17
	Anemia	18	11
	Febrile neutropenia	4	4
Cardiac disorders	Atrial fibrillation	11	6
Gastrointestinal disorders	Diarrhea	54	5
	Nausea	33	1
	Constipation	29	0
	Vomiting	25	0
	Abdominal pain	20	5
	Stomatitis	14	1
	Dyspepsia	12	0
General disorders and administration site conditions	Fatigue	50	5
	Edema peripheral	26	2
	Pyrexia	19	1
	Asthenia	14	3
Infections and infestations	Upper respiratory tract infection	28	0
	Urinary tract infection	16	4
	Sinusitis	15	1
	Pneumonia	14	7
Injury, poisoning and procedural complications	Contusion	18	0
	Subdural hematoma	4	2
Metabolism and nutrition disorders	Decreased appetite	24	2
	Hyperuricemia	17	5
	Dehydration	14	4
Musculoskeletal and connective tissue disorders	Back pain	15	1
	Arthralgia	18	0
	Muscle spasms	14	0
	Myalgia	16	0
	Pain in extremity	14	0
Nervous system disorders	Dizziness	14	0
	Headache	14	0
Psychiatric disorders	Insomnia	11	0
Renal and urinary disorders	Renal failure acute	5	2
Respiratory, thoracic and mediastinal disorders	Dyspnea	32	4
	Cough	22	0
	Epistaxis	11	0
Skin and subcutaneous tissue disorders	Rash	18	2
	Pruritus	11	0
Vascular disorders	Hypertension	11	5

[†] Adverse reactions occurring at ≥10% incidence or serious adverse reactions ≥2% incidence are presented.

Serious adverse reactions were reported in approximately 60% of patients (treatment-emergent frequencies).

Isolated cases of leukostasis have been observed (see **WARNINGS AND PRECAUTIONS, Hematologic**).

Abnormal Hematologic and Clinical Chemistry Findings (MCL)

Table 10: Hematologic laboratory abnormalities (per CTCAE criteria) from Study PCYC-1104-CA

Laboratory Parameter	IMBRUVICA [®] (N=111)	
	All Grades (%)	Grades 3 or 4 (%)
Hemoglobin decreased ^a	39	4
Neutrophils decreased ^b	46	24
Platelets decreased ^c	57	14

^a Units=g/L; grade 1: ≥100 to <lower limit of normal; grade 2: ≥80 to <100; grade 3: <80.

^b Units= $\times 10^9/L$; grade 1: ≥1.5 to <lower limit of normal; grade 2: ≥1.0 to <1.5; grade 3: ≥0.5 to <1.0; grade 4: <0.5.

^c Units= $10^9/L$; grade 1: ≥75.0 to <lower limit of normal; grade 2: ≥50.0 to <75.0; grade 3: ≥25.0 to <50.0; grade 4: <25.0.

Marginal zone lymphoma

Adverse reactions described in Table 11 below reflect exposure to IMBRUVICA[®] with a median treatment duration of 11.6 months in study PCYC-1121-CA. Patients received IMBRUVICA[®] until disease progression or unacceptable toxicity. Hematologic laboratory abnormalities are described in Table 12.

Table 11: Adverse reactions reported in ≥10% of patients with MZL treated with 560 mg IMBRUVICA[®] - Study PCYC-1121-CA (N=63)

System Organ Class	Adverse Reaction	All Grades (%)	Grades 3-4 (%)
Infections and infestations	Upper respiratory tract infection	21	0
	Sinusitis*	19	0
	Bronchitis	11	0
	Pneumonia*	11	10
Blood and lymphatic system disorders	Anemia	33	14
	Thrombocytopenia*	25	2
	Neutropenia*	8	8
Metabolism and nutrition disorders	Decreased appetite	16	2
	Hyperuricemia	16	0
	Hypoalbuminemia	14	0
	Hypokalemia	13	0
Psychiatric disorders	Anxiety	16	2
Nervous system disorders	Dizziness	19	0
	Headache	13	0
Vascular disorders	Hemorrhage*	30	0
	Hypertension*	14	5
Respiratory, thoracic and mediastinal disorders	Cough	22	2
	Dyspnea	21	2
Gastrointestinal disorders	Diarrhea	43	5
	Nausea	25	0
	Dyspepsia	19	0
	Stomatitis*	17	2
	Abdominal pain	16	2
	Constipation	14	0
	Abdominal pain upper	13	0
Vomiting	11	2	
Skin and subcutaneous tissue disorders	Bruising*	41	0
	Rash*	29	5
	Pruritus	14	0

System Organ Class	Adverse Reaction	All Grades (%)	Grades 3-4 (%)
Musculoskeletal and connective tissue disorders	Musculoskeletal pain*	40	3
	Arthralgia	24	2
	Muscle spasms	19	3
General disorders and administration site conditions	Fatigue	44	6
	Edema peripheral	24	2
	Pyrexia	17	2

* Includes multiple adverse reaction terms.

Table 12: Hematologic laboratory abnormalities (per CTCAE criteria) from Study PCYC-1121

Laboratory Parameter	IMBRUVICA® (N=63)	
	All Grades (%)	Grades 3 or 4 (%)
Hemoglobin decreased ^a	43	13
Neutrophils decreased ^b	22	13
Platelets decreased ^c	49	6

^a Units=g/L; grade 1: ≥100 to <lower limit of normal; grade 2: ≥80 to <100; grade 3: <80.

^b Units= $\times 10^9/L$; grade 1: ≥1.5 to <lower limit of normal; grade 2: ≥1.0 to <1.5; grade 3: ≥0.5 to <1.0; grade 4: <0.5.

^c Units= $10^9/L$; grade 1: ≥75.0 to <lower limit of normal; grade 2: ≥50.0 to <75.0; grade 3: ≥25.0 to <50.0; grade 4: <25.0.

Waldenström's Macroglobulinemia

Single-agent therapy

Adverse reactions described in Table 13 below reflect exposure to IMBRUVICA® (420 mg daily) with a median duration of 11.7 months in Study PCYC-1118E. Patients received IMBRUVICA® until disease progression or unacceptable toxicity. Hematologic laboratory abnormalities are described in Table 14.

Table 13: Adverse reactions[†] reported from Study PCYC-1118E (N=63)

System Organ Class	Adverse Reaction	Frequency	
		All grades (%)	Grades 3 or 4 (%)
Blood and lymphatic system disorders	Neutropenia	25	17
	Thrombocytopenia	17	13
	Anemia	16	3
Gastrointestinal disorders	Diarrhea	37	0
	Nausea	21	0
	Stomatitis*	16	0
	Gastroesophageal reflux disease	13	0
General disorders and administration site conditions	Fatigue	21	0
Infections and infestations	Sinusitis	19	0
	Upper respiratory tract infection	19	0
	Pneumonia*	14	6
	Skin infection*	14	2
Musculoskeletal and connective tissue disorders	Muscle spasms	21	0
	Arthropathy	13	0
Neoplasms benign, malignant and unspecified (incl. cysts and polyps)	Skin cancer*	11	0
Nervous system disorders	Dizziness	14	0
	Headache	13	0

System Organ Class	Adverse Reaction	Frequency	
		All grades (%)	Grades 3 or 4 (%)
Respiratory, thoracic and mediastinal disorders	Epistaxis	19	0
	Cough	13	0
Skin and subcutaneous tissue disorders	Rash*	22	0
	Bruising*	16	0
	Pruritus	11	0

* Includes multiple adverse reaction terms.

† Adverse reactions occurring at ≥10% incidence or that are biologically plausible are presented.

Abnormal Hematologic and Clinical Chemistry Findings (WM, single-agent therapy)

Table 14: Hematologic laboratory abnormalities (per CTCAE criteria) from Study PCYC-1118E

Laboratory Parameter	IMBRUVICA® (N=63)	
	All Grades (%)	Grades 3 or 4 (%)
Hemoglobin decreased ^a	13	8
Neutrophils decreased ^b	44	19
Platelets decreased ^c	43	13

^a Units=g/L; grade 1: ≥100 to <lower limit of normal; grade 2: ≥80 to <100; grade 3: <80.

^b Units=x10⁹/L; grade 1: ≥1.5 to <lower limit of normal; grade 2: ≥1.0 to <1.5; grade 3: ≥0.5 to <1.0; grade 4: <0.5.

^c Units=10⁹/L; grade 1: ≥75.0 to <lower limit of normal; grade 2: ≥50.0 to <75.0; grade 3: ≥25.0 to <50.0; grade 4: <25.0.

The safety profile of IMBRUVICA® in patients with previously treated WM who failed prior rituximab-containing therapy in the PCYC-1127-CA non-randomized single-agent therapy substudy arm (N=31) was consistent with the safety profile for IMBRUVICA® in Study PCYC-1118E.

Combination therapy

Adverse reactions described in Table 15 below reflect exposure to IMBRUVICA® + rituximab with a median duration of 25.8 months and exposure to placebo + rituximab with a median duration of 15.5 months in patients with WM in Study PCYC-1127-CA. Rituximab was administered weekly for 4 consecutive weeks over two courses (weeks 1-4 and 17-20), and IMBRUVICA® or placebo was administered daily until disease progression or unacceptable toxicity. Hematologic laboratory abnormalities are described in Table 16.

Table 15: Adverse reactions reported from Study PCYC-1127-CA^a

System Organ Class Adverse Reaction Term	IMBRUVICA® + Rituximab (N=75)		Placebo + Rituximab (N=75)	
	All Grades %	Grade 3 or 4 %	All Grades %	Grade 3 or 4 %
Blood and lymphatic system disorders				
Anemia	19	11	29	17
Neutropenia*	16	12	11	4
Cardiac disorders				
Atrial fibrillation	15	12	3	1
Cardiac failure congestive	3	3	0	0
Myocardial ischemia	3	1	0	0
Gastrointestinal disorders				
Diarrhea	28	0	15	1
Nausea	21	0	12	0
Dyspepsia	16	0	1	0

System Organ Class Adverse Reaction Term	IMBRUVICA® + Rituximab (N=75)		Placebo + Rituximab (N=75)	
	All Grades %	Grade 3 or 4 %	All Grades %	Grade 3 or 4 %
General disorders and administration site conditions				
Peripheral edema	17	0	12	1
Infections and infestations				
Pneumonia*	19	13	5	3
Skin infection*	17	3	3	0
Urinary tract infection	13	0	0	0
Bronchitis	12	3	7	0
Influenza	12	0	7	1
Gastroenteritis	7	3	1	0
Respiratory tract infection	7	3	3	0
Injury, poisoning and procedural complications				
Fall	4	3	4	0
Metabolism and nutrition disorders				
Hypokalemia	11	0	1	1
Musculoskeletal and connective tissue disorders				
Musculoskeletal pain*	35	4	21	3
Arthralgia	24	3	11	1
Muscle spasms	17	0	12	1
Psychiatric disorders				
Insomnia	11	0	4	0
Respiratory, thoracic, and mediastinal disorders				
Cough	17	0	11	0
Skin and subcutaneous tissue disorders				
Bruising*	37	1	5	0
Rash*	24	1	11	0
Vascular disorders				
Hemorrhage*	32	3	17	3
Hypertension*	20	13	5	4

^a Occurring at $\geq 10\%$ incidence and $\geq 5\%$ greater in the IMBRUVICA® + rituximab arm when compared to the placebo + rituximab arm or serious adverse events $\geq 2\%$ incidence and $\geq 2\%$ greater in the IMBRUVICA® + rituximab arm when compared to the placebo + rituximab arm or that are biologically plausible.

Events are sorted by system organ class and by decreasing frequency of adverse reaction term in the IMBRUVICA® + rituximab arm.

* Includes multiple adverse reaction terms

Grade 3 or 4 infusion-related reactions were observed in 1% of patients treated with IMBRUVICA® + rituximab and 16% of patients treated with placebo + rituximab.

Abnormal Hematologic and Clinical Chemistry Findings (WM, IMBRUVICA® + rituximab Therapy)

Table 16: Hematologic laboratory abnormalities (per CTCAE criteria) from Study PCYC-1127-CA

Laboratory Parameter	IMBRUVICA®+Rituximab (N=75) n (%)		Placebo+Rituximab (N=75) n (%)	
	Any Grade	Grade 3+4	Any Grade	Grade 3+4
Hemoglobin decreased ^a	12 (16.0)	1 (1.3)	18 (24.0)	8 (10.7)
Neutrophils decreased ^b	19 (25.3)	7 (9.3)	16 (21.3)	5 (6.7)
Platelets decreased ^c	17 (22.7)	1 (1.3)	13 (17.3)	4 (5.3)

N: number of patients who received at least 1 dose of ibrutinib in each analysis population; R: rituximab.

^a Units=g/L; grade 1: ≥ 100 to <lower limit of normal; grade 2: ≥ 80 to <100; grade 3: <80.

^b Units= $\times 10^9/L$; grade 1: ≥ 1.5 to <lower limit of normal; grade 2: ≥ 1.0 to <1.5; grade 3: ≥ 0.5 to <1.0; grade 4: <0.5.

^c Units= $10^9/L$; grade 1: ≥ 75.0 to <lower limit of normal; grade 2: ≥ 50.0 to <75.0; grade 3: ≥ 25.0 to <50.0; grade 4: <25.0.

Abnormalities worsened after first dose of study treatment up to 30 days after the last dose of study drug were included in this table.

Chronic graft versus host disease

Adverse reactions described below in Table 17 reflect exposure to IMBRUVICA[®] (420 mg daily) with a median duration of 4.4 months in the cGVHD study. Hematologic laboratory abnormalities are described in Table 18.

Table 17: Adverse reactions reported in $\geq 10\%$ of patients with cGVHD treated with 420 mg IMBRUVICA[®] - Study 1129 (N=42)

System Organ Class	Adverse Reaction	All Grades (%)	Grades 3 or 4 (%)
Infections and infestations	Pneumonia*	21	10
	Upper respiratory tract infection	19	0
	Sepsis*	10	10
Metabolism and nutrition disorders	Hypokalemia	12	7
Nervous system disorders	Headache	17	5
Vascular disorders	Hemorrhage*	26	0
Respiratory, thoracic and mediastinal disorders	Cough	14	0
	Dyspnea	12	2
Gastrointestinal disorders	Diarrhea	36	10
	Stomatitis*	29	2
	Nausea	26	0
	Constipation	12	0
Skin and subcutaneous tissue disorders	Bruising*	41	0
	Rash*	12	0
Musculoskeletal and connective tissue disorders	Muscle spasms	29	2
	Musculoskeletal pain*	14	5
General disorders and administration site conditions	Fatigue	57	12
	Pyrexia	17	5
	Edema peripheral	12	0
Injury, poisoning and procedural complications	Fall	17	0

* Includes multiple adverse reaction terms.

Table 18: Hematologic laboratory abnormalities (per CTCAE criteria) from Study PCYC-1129-CA

Laboratory Parameter	IMBRUVICA [®] (N=42)	
	All Grades (%)	Grades 3 or 4 (%)
Hemoglobin decreased ^a	24	2
Neutrophils decreased ^b	10	10
Platelets decreased ^c	33	0

^a Units=g/L; grade 1: ≥ 100 to <lower limit of normal; grade 2: ≥ 80 to <100; grade 3: <80.

^b Units= $\times 10^9/L$; grade 1: ≥ 1.5 to <lower limit of normal; grade 2: ≥ 1.0 to <1.5; grade 3: ≥ 0.5 to <1.0; grade 4: <0.5.

^c Units= $10^9/L$; grade 1: ≥ 75.0 to <lower limit of normal; grade 2: ≥ 50.0 to <75.0; grade 3: ≥ 25.0 to <50.0; grade 4: <25.0.

Post-Market Adverse Drug Reactions

The following adverse reactions have been reported during post-marketing experience. Because these reactions are reported voluntarily from a population of uncertain size, it is not always possible to estimate their frequency reliably or establish a causal relationship to drug exposure.

Cardiac disorders: ventricular tachyarrhythmias (see **WARNINGS AND PRECAUTIONS**)

Hepatobiliary disorders: hepatic failure including acute and/or fatal events (including cases that lacked clear alternative explanation and in which a positive de-challenge/re-challenge was observed), hepatic cirrhosis

Immune system disorders: hypersensitivity reaction, interstitial lung disease (ILD) (see **WARNINGS AND PRECAUTIONS**)

Infections and infestations: progressive multifocal leukoencephalopathy (PML), hepatitis B reactivation (see **WARNINGS AND PRECAUTIONS**)

Metabolism and nutrition disorders: tumour lysis syndrome (see **WARNINGS AND PRECAUTIONS**)

Nervous system disorders: peripheral neuropathy, cerebrovascular accident (includes events with fatal outcome), transient ischemic attack, ischemic stroke (includes events with fatal outcome) (see **WARNINGS AND PRECAUTIONS**)

Skin and subcutaneous tissue disorders: angioedema, erythema, onychoclasia (commonly reported in clinical trials), panniculitis, Stevens-Johnson syndrome, urticaria

Vascular disorders: hemorrhage (see **WARNINGS AND PRECAUTIONS**)

DRUG INTERACTIONS

Serious Drug Interactions

Concomitant use of IMBRUVICA[®] with a strong CYP3A inhibitor should be avoided (see **DOSAGE AND ADMINISTRATION, Concomitant use of CYP3A Inhibitors**).

Overview

Ibrutinib is metabolized primarily by cytochrome P450 enzyme 3A. Ibrutinib is an inhibitor of P-glycoprotein (P-gp) and breast cancer resistance protein (BCRP) *in vitro*. IMBRUVICA[®] should not be used concomitantly with strong inhibitors or inducers of CYP3A.

Drug-Drug Interactions

Agents that may increase ibrutinib plasma concentrations

Co-administration of ketoconazole, a strong CYP3A inhibitor, in healthy subjects increased exposure (C_{max} and AUC_{∞}) of ibrutinib by 29- and 26-fold, respectively. Simulations under fed conditions suggest that posaconazole (a strong CYP3A inhibitor) may increase the AUC of ibrutinib 7-fold to 10-fold.

In patients with B-cell malignancies, concomitant use of strong inhibitors of CYP3A (e.g., ketoconazole, indinavir, nelfinavir, ritonavir, saquinavir, clarithromycin, itraconazole, cobicistat, and posaconazole) should be avoided and an alternative with less CYP3A inhibitory potential should be considered. If a strong CYP3A inhibitor must be used short term (7 days or less), withhold IMBRUVICA[®] treatment temporarily for the duration of the CYP3A inhibitor treatment.

In patients with B-cell malignancies, co-administration of CYP3A inhibitors erythromycin and voriconazole increased C_{max} by 3.4-fold and 6.7-fold and increased AUC by 3.0-fold and 5.7-fold, respectively. If a moderate CYP3A inhibitor (e.g., erythromycin, aprepitant, atazanavir, ciprofloxacin, crizotinib, darunavir/ritonavir, diltiazem, fluconazole, fosamprenavir, imatinib, verapamil, amiodarone, dronedarone) is indicated, reduce IMBRUVICA[®] dose to 280 mg for the duration of the CYP3A inhibitor use. If voriconazole is indicated, reduce IMBRUVICA[®] dose to 140 mg for the duration of the CYP3A inhibitor use. No dose adjustment is required in combination with mild CYP3A inhibitors.

In patients with cGVHD, if used concomitantly with voriconazole, or posaconazole at doses less than or equal to 200 mg BID (suspension), reduce the IMBRUVICA[®] dose to 280 mg for the duration of the CYP3A inhibitor use. If used concomitantly with posaconazole at 300 mg QD (delayed release tablet), reduce the IMBRUVICA[®] dose to 140 mg for the duration of the CYP3A inhibitor use. Concomitant use with posaconazole at higher doses or with other strong CYP3A inhibitors should be avoided; if used short term (7 days or less), withhold IMBRUVICA[®] treatment temporarily for the duration of the CYP3A inhibitor treatment. No dose adjustment is required in combination with moderate CYP3A inhibitors, or with mild CYP3A inhibitors.

Patients should be monitored closely for toxicity. Follow dose modification guidelines as needed (see **DOSAGE AND ADMINISTRATION**).

Agents that may decrease ibrutinib plasma concentrations

Administration of IMBRUVICA[®] with strong inducers of CYP3A (e.g., rifampin) decreases ibrutinib plasma exposures by approximately 10-fold and the dihydrodiol metabolite by 2.5-fold. Avoid concomitant use of strong CYP3A inducers (e.g., carbamazepine, rifampin, phenytoin, and St. John's Wort). Consider alternative agents with less CYP3A induction. IMBRUVICA[®] can be administered concomitantly with mild inducers.

Drugs that may have their plasma concentrations altered by ibrutinib

Ibrutinib is an inhibitor of P-glycoprotein (P-gp) *in vitro*. Ibrutinib may inhibit intestinal P-gp after a therapeutic dose and alter the absorption of co-dosed drugs that are P-gp substrates (e.g., aliskiren, digoxin, fexofenadine). There are no clinical data available.

In vitro studies have also demonstrated that ibrutinib inhibits the breast cancer resistance protein (BCRP). *In vivo* studies to confirm the transporter-based interaction have not been conducted. Ibrutinib may inhibit intestinal BCRP after a therapeutic dose and alter the absorption of co-dosed drugs that are BCRP substrates (e.g., methotrexate, topotecan, imatinib). Ibrutinib may also inhibit BCRP in the liver and increase the exposure of drugs that undergo BCRP-mediated hepatic efflux, such as rosuvastatin.

To avoid a potential interaction in the GI tract, narrow therapeutic range BCRP and P-gp substrates should be taken at least 6 hours before or after IMBRUVICA[®]. Dose reduction of concomitant drugs that undergo BCRP-mediated hepatic efflux may be needed to avoid increased exposure and to reduce the risk of serious adverse reactions.

Anticoagulant and antiplatelet agents

Warfarin or other vitamin K antagonists should not be administered concomitantly with IMBRUVICA[®]. Use of IMBRUVICA[®] in patients requiring other anticoagulants or medications that inhibit platelet function may increase the risk of bleeding and should be used with caution (see **WARNINGS AND PRECAUTIONS, Hemorrhage**).

Drugs that Prolong the PR Interval

IMBRUVICA[®] causes an increase in the PR interval (see **WARNINGS AND PRECAUTIONS** and **ACTION AND CLINICAL PHARMACOLOGY**). The concomitant use of IMBRUVICA[®] with other drugs that prolong the PR interval, including, but not limited to, beta blockers, non-dihydropyridine calcium channel blockers, and digitalis glycosides, as well as certain antiarrhythmics and HIV protease inhibitors, should be undertaken with caution.

Drug-Food Interactions

Co-administration of grapefruit juice in non-fasted healthy subjects increased exposure (C_{max} and AUC_{last}) of ibrutinib by approximately 4 and 2-fold, respectively. Grapefruit and Seville oranges must not be consumed during IMBRUVICA[®] treatment as they contain moderate inhibitors of CYP3A (see **DOSAGE AND ADMINISTRATION**).

Supplements such as fish oil, flaxseed, and vitamin E preparations should be avoided as they may increase the risk of bleeding associated with IMBRUVICA[®] (see **WARNINGS AND PRECAUTIONS, Hemorrhage**).

Administration with food increases AUC of ibrutinib by approximately 2-fold and C_{max} by up to 4.5-fold as compared to overnight fasting. Administration with food increases the exposure of the dihydrodiol metabolite by approximately 2-fold as compared to overnight fasting (see **ACTION AND CLINICAL PHARMACOLOGY, Pharmacokinetics**). IMBRUVICA[®] can be taken with or without food.

Drug-Herb Interactions

Avoid concomitant use of St. John's Wort, as this herb is a strong inducer of CYP3A.

Drug-Lifestyle Interactions

Fatigue, dizziness and asthenia have been reported very commonly in patients taking IMBRUVICA[®] and should be considered when assessing a patient's ability to drive or operate machines.

DOSAGE AND ADMINISTRATION

Dosing Considerations

IMBRUVICA[®] should be administered orally, with or without food, with a glass of water once daily, at approximately the same time each day. IMBRUVICA[®] should be swallowed whole with

water and should not be opened, broken, or chewed. IMBRUVICA[®] must not be taken with grapefruit juice.

Upon initiation of treatment with IMBRUVICA[®], a reversible increase in lymphocyte counts, often associated with reduction of lymphadenopathy, has been observed in a majority of patients with CLL and some patients with MCL. This observed lymphocytosis may be a pharmacodynamic effect of the inhibition of BTK-mediated cellular homing and adhesion, and should not be considered progressive disease in the absence of other clinical findings (see **ACTION AND CLINICAL PHARMACOLOGY**).

Recommended Dose and Dosage Adjustment

The recommended dose of IMBRUVICA[®] for CLL or WM is 420 mg once daily until disease progression or no longer tolerated by the patient.

In patients with previously untreated CLL, IMBRUVICA[®] can also be used in combination with obinutuzumab. For information on the dosing of obinutuzumab, consult the Product Monograph.

In patients with previously treated CLL, IMBRUVICA[®] can also be used in combination with bendamustine and rituximab. For information on dosing of bendamustine and rituximab, consult the corresponding Product Monographs.

In patients with WM, IMBRUVICA[®] can also be used in combination with rituximab. For information on dosing and administration of rituximab, consult the Product Monograph. For rituximab dosing used in the pivotal clinical study, see **CLINICAL TRIALS, Waldenström's Macroglobulinemia (WM), Combination Therapy**.

When administering IMBRUVICA[®] in combination with rituximab or obinutuzumab, consider administering IMBRUVICA[®] prior to rituximab or obinutuzumab when given on the same day.

The recommended dose of IMBRUVICA[®] for MCL or MZL is 560 mg once daily until disease progression or no longer tolerated by the patient.

The recommended dose of IMBRUVICA[®] for cGVHD is 420 mg once daily until cGVHD progression, recurrence of an underlying malignancy, or until no longer tolerated by the patient. When a patient no longer requires therapy for the treatment of cGVHD, IMBRUVICA[®] should be discontinued considering the medical assessment of the individual patient.

IMBRUVICA[®] therapy should be withheld for any new onset or worsening Grade ≥ 3 non-hematological toxicities, Grade ≥ 3 neutropenia with infection or fever, or Grade 4 hematological toxicities. Once the symptoms of the toxicity have resolved to Grade 1 or baseline (recovery), IMBRUVICA[®] therapy may be reinitiated at the starting dose. If the toxicity reoccurs, reduce dose by 140 mg per day. A second reduction of dose by 140 mg may be considered as needed. If these toxicities persist or recur following two dose reductions, discontinue IMBRUVICA[®].

Recommended dose modifications for these toxicities are described below:

Toxicity occurrence	CLL/WM/cGVHD dose modification after recovery	MCL/MZL dose modification after recovery
First	restart at 420 mg daily	restart at 560 mg daily
Second	restart at 280 mg daily	restart at 420 mg daily
Third	restart at 140 mg daily	restart at 280 mg daily
Fourth	discontinue IMBRUVICA [®]	discontinue IMBRUVICA [®]

Patients with Hepatic Impairment

IMBRUVICA[®] should not be used in patients with moderate (Child-Pugh class B) or severe hepatic impairment (Child-Pugh class C) (see **WARNINGS AND PRECAUTIONS, Special Populations**). If the benefit is considered to outweigh the risk in a patient with mild hepatic impairment (Child Pugh class A), a dose reduction to 140 mg should be considered. Monitor patients for signs of toxicity.

Concomitant use of CYP3A Inhibitors

Concomitant use of moderate and strong CYP3A inhibitors increases the exposure of ibrutinib (see **DRUG INTERACTIONS**). Avoid concomitant use with strong CYP3A inhibitors. If a strong or moderate CYP3A inhibitor must be used, refer to the dosing recommendations in the table below. After discontinuation of the strong or moderate CYP3A inhibitor, resume the previous dose of IMBRUVICA[®] if it had been adjusted or withheld. No dose adjustment is required in combination with mild inhibitors. Patients should be monitored closely for toxicity. Follow dose modification guidelines as needed.

Patient Population	Co-administered Drug	Recommended IMBRUVICA® Dose for the Duration of the Inhibitor Use ^a
B-Cell Malignancies	• Mild CYP3A inhibitors	420 mg or 560 mg once daily per indication. No dose adjustment required.
	• Moderate CYP3A inhibitors	280 mg once daily for the duration of the CYP3A inhibitor use.
	• Voriconazole	140 mg once daily for the duration of the CYP3A inhibitor use.
	• Strong CYP3A inhibitors	Concomitant use should be avoided and an alternative with less CYP3A inhibitory potential should be considered. If a strong CYP3A inhibitor must be used short term (7 days or less), withhold IMBRUVICA® treatment temporarily for the duration of the CYP3A inhibitor treatment.
Chronic Graft versus Host Disease	• Mild CYP3A inhibitors	420 mg once daily. No dose adjustment required.
	• Moderate CYP3A inhibitors	420 mg once daily. No dose adjustment required.
	• Voriconazole • Posaconazole at doses less than or equal to 200 mg BID (suspension)	280 mg once daily for the duration of the CYP3A inhibitor use.
	• Posaconazole at 300 mg QD (delayed-release tablet)	140 mg once daily for the duration of the CYP3A inhibitor use.
	• Strong CYP3A inhibitors • Posaconazole at doses higher than 200 mg BID (suspension) or 300 mg QD (delayed-release tablet)*	Concomitant use should be avoided and an alternative with less CYP3A inhibitory potential should be considered. If a strong CYP3A inhibitor must be used short term (7 days or less), withhold IMBRUVICA® treatment temporarily for the duration of the CYP3A inhibitor treatment.

*Posaconazole at higher doses includes posaconazole suspension 200 mg three times daily or 400 mg twice daily, and posaconazole IV injection 300 mg once daily.

^a Based on a combination of observed data and physiologically based pharmacokinetics simulations

Pediatrics (< 18 years old)

Health Canada has not authorized an indication for pediatric use.

Missed Dose

If a dose of IMBRUVICA® is not taken at the scheduled time, it can be taken as soon as possible on the same day with a return to the normal schedule the following day. The patient should not take extra doses to make up the missed dose.

OVERDOSAGE

There are limited data on the effects of IMBRUVICA® overdose. No Maximum Tolerated Dose was reached in the phase 1 study in which a small number of patients received up to 12.5 mg/kg/day (1400 mg/day). In a separate study, one healthy subject who received a dose of

1680 mg experienced reversible Grade 4 hepatic enzyme increases [aspartate aminotransferase (AST) and alanine aminotransferase (ALT)]. There is no specific antidote for IMBRUVICA[®]. Patients who ingest more than the recommended dosage should be closely monitored and given appropriate supportive treatment.

For management of a suspected drug overdose, contact your regional Poison Control Centre.

ACTION AND CLINICAL PHARMACOLOGY

Mechanism of Action

Ibrutinib is a small-molecule, targeted inhibitor of Bruton's tyrosine kinase (BTK). Ibrutinib forms a covalent bond with a cysteine residue (Cys-481) in the BTK active site, leading to inhibition of BTK enzymatic activity. BTK, a member of the Tec kinase family, is a signaling molecule of the B-cell antigen receptor (BCR) pathway. The BCR pathway is implicated in the pathogenesis of several B-cell malignancies including CLL. In addition to its roles in antigen mediated BCR signaling, BTK is involved in signaling of chemokine receptors such as CXCR4 and CXCR5 that play roles in B-cell trafficking and tissue homing. Nonclinical studies have shown that ibrutinib inhibits malignant B-cell proliferation and survival as well as cell migration and substrate adhesion.

Pharmacodynamics

Lymphocytosis

Upon initiation of IMBRUVICA[®] as a single agent in controlled CLL clinical studies, a reversible increase in lymphocyte counts (i.e., $\geq 50\%$ increase from baseline and above absolute count 5000/ μL), often associated with reduction of lymphadenopathy, occurred in a majority (57% to 69%) of patients. In a study of patients receiving IMBRUVICA[®] in combination with BR, lymphocytosis occurred in 7% of patients. In a study of patients receiving IMBRUVICA[®] in combination with obinutuzumab, lymphocytosis occurred in 7% of patients. In the MCL clinical study, this effect occurred in some patients (35%) treated with IMBRUVICA[®]. This observed lymphocytosis may be a pharmacodynamic effect of the inhibition of BTK-mediated cellular homing and adhesion, and should not be considered progressive disease in the absence of other clinical findings. Lymphocytosis typically occurs during the first few weeks of IMBRUVICA[®] therapy (median time 1 to 2 weeks) and typically resolves within a median 12 to 14 weeks in patients with CLL, and within a median 8 weeks in patients with MCL.

A large increase in the number of circulating lymphocytes (e.g., to above 400,000/ μL) has been observed in some patients and may confer increased risk of leukostasis.

Lymphocytosis was not observed in patients with WM treated with IMBRUVICA[®].

Cardiac Electrophysiology

A randomized, double-blind, placebo- and positive-controlled, single-dose, four-way crossover study was performed to evaluate the effects of ibrutinib at supratherapeutic doses of 840 mg and

1680 mg on ECG interval parameters in healthy subjects of whom 9 received ibrutinib (either 840 or 1680 mg), the negative control (placebo), and the positive control (moxifloxacin).

Ibrutinib caused a dose- and concentration-dependent prolongation of the PR interval. The maximum difference from placebo in the mean change from baseline PR interval was 3.9 ms (90% CI: 0.17, 7.70) at the 840 mg dose and 7.6 ms (90% CI: 3.04, 12.10) at the 1680 mg dose.

Ibrutinib was also observed to decrease heart rate. The maximum difference from placebo in the mean change from baseline heart rate was -4.8 bpm (90% CI: -9.08, -0.54) at the 840 mg dose and -5.9 bpm (90% CI: -9.49, -2.28) at the 1680 mg dose.

In this study, mean C_{max} values of 304 ng/mL (range 60-670 ng/mL) and 719 ng/mL (range 261-1890 ng/mL) were reported following single dose administration of the 840 mg and 1680 mg doses, respectively. The mean steady-state C_{max} observed in subjects who received daily doses of 560 mg was 164 ng/mL (range 5.23-956 ng/mL).

Based on an exposure-response analysis using data from this study, a concentration dependent shortening in the QTcF interval was predicted, with an estimated change in QTcF of -3.8 ms [90% CI -5.88, -1.80] and -7.1 ms [90% CI -10.2, -3.94] at the 840 and 1680 mg supratherapeutic doses, respectively.

Pharmacokinetics

Absorption

Ibrutinib is rapidly absorbed after oral administration with a median T_{max} of 1 to 2 hours. Absolute bioavailability in fasted condition (n=8) was 2.9% (90% CI: 2.1; 3.9) and when combined with a meal was 7.6% (90% CI: 6.4; 9.0). Population pharmacokinetic modeling suggests that the pharmacokinetics of ibrutinib does not differ significantly in patients with different B-cell malignancies. Ibrutinib exposure increases with doses up to 840 mg. The pharmacokinetic parameters of ibrutinib as a single agent at steady-state are shown in Table 19. High intersubject variability of exposures was observed in patients.

Table 19: Ibrutinib pharmacokinetic parameters at steady-state in patients with B-cell malignancies

	AUC _{0-24h}				C _{max}			
	n	Mean (SD) (ng.h/mL)	Range (ng.h/mL)	CV (%)	n	Mean (SD) (ng/mL)	Range (ng/mL)	CV (%)
420 mg	71	732 (521)	102 - 2333	71.1	73	137 (118)	11.2 - 609	86.1
560 mg	43	953 (705)	115 - 3372	74.0	45	164 (164)	5.23 - 956	99.9

Ibrutinib exposure was consistent between patients with WM on combination therapy of ibrutinib 420 mg/day with rituximab, and patients with B-cell malignancies on single agent ibrutinib at 420 mg/day.

In patients at 420 mg with cGVHD, the steady state AUC observed was (mean ± standard deviation) 1159 ± 583 ng·h/mL.

Administration of ibrutinib with a high-fat breakfast resulted in approximately 2.0-fold higher AUC_{last} and up to 4.5-fold higher C_{max} as compared to overnight fasting. Administration with

food increases the exposure of the dihydrodiol metabolite by approximately two-fold compared to administration after overnight fasting. A delay in T_{\max} (from ~2 to 4 hours) was also observed with food.

Distribution

Binding of ibrutinib to human plasma proteins *in vitro* was 97.3% with no concentration dependence in the range of 50 to 1000 ng/mL. The volume of distribution (V_d) was 683 L and the apparent volume of distribution at steady state ($V_{d,ss}/F$) is approximately 10,000 L. Binding of the dihydrodiol metabolite to human plasma protein *in vitro* is 91% at 475 ng/mL.

The proportion of unbound ibrutinib is inversely related to the plasma levels of α 1-acid glycoprotein and albumin in humans. Approximately 12% C_{\max} and 51% AUC_{0-72h} of total radioactivity were accounted for by covalent binding in the plasma of healthy male volunteers administered a single dose of 140 mg ibrutinib admixed with ^{14}C -ibrutinib. *In vitro*, ibrutinib binds both reversibly and covalently to human serum albumin and, to a lesser extent, to α 1-acid glycoprotein.

Metabolism

Ibrutinib is extensively metabolized, primarily by cytochrome P450, CYP3A, to produce a prominent dihydrodiol metabolite with an inhibitory activity towards BTK approximately 15 times lower than that of ibrutinib. Systemic steady-state exposure to the dihydrodiol metabolite is 2.5-fold that of the parent drug in patients administered 420 mg daily dose. Other main circulating metabolites include M25 (oxidative opening of the piperidine with further oxidation to a carboxylic acid), M34 (oxidative opening of the piperidine with further reduction to a primary alcohol), M23 (resulting from amide hydrolysis) and M21 (hydroxylation of the phenyl moiety followed by sulfation). M23, M25 and M34 have low to negligible activity towards BTK and activity of M21 has not been studied. Steady-state exposure of these metabolites is not known.

In vitro studies suggest that CYP2D6 involvement in ibrutinib oxidative metabolism is minor. *In vitro* enzyme kinetic studies demonstrated that the rate of metabolism of ibrutinib to its dihydrodiol metabolite by human recombinant CYP2D6 was lower with the poor metabolizer phenotype compared to that of wildtype. As part of the human mass balance study, two subjects genotyped as poor metabolizers for CYP2D6, showed a similar pharmacokinetic profile as four extensive metabolizers.

Elimination

Intravenous clearance was 62 and 76 L/h in fasted and fed condition, respectively. In line with the high first-pass effect, the apparent oral clearance is approximately 2000 and 1000 L/h in fasted and fed condition, respectively.

The half-life of ibrutinib is 4 to 6 hours. The half-life of the dihydrodiol metabolite is 6 to 11 hours. Compared to when a single dose of ibrutinib was given, accumulation of less than two-fold of both parent compound and the dihydrodiol metabolite following daily dose regimen was observed.

After a single oral administration of 140 mg ibrutinib admixed with [¹⁴C]-ibrutinib in healthy subjects, approximately 90% of radioactivity was excreted within 168 hours, with the majority (80%) excreted in the feces and less than 10% accounted for in urine. Unchanged ibrutinib accounted for approximately 1% of the radiolabeled excretion product in feces and none in urine, with the remainder of the dose being metabolites.

Drug-drug interactions

In a sequential design trial of 18 healthy volunteers, a single dose of 120 mg of IMBRUVICA[®] was administered alone on Day 1 and a single dose of 40 mg of IMBRUVICA[®] was administered on Day 7 in combination with 400 mg of ketoconazole (given daily on Days 4 to 9). Ketoconazole increased ibrutinib dose-normalized C_{max} and AUC_{last} 29-fold and 24-fold, respectively. The corresponding decrease in dose-normalized C_{max} and AUC_{last} of the dihydrodiol metabolite was 2.6-fold and 1.2-fold, respectively. Drug-drug interaction studies of ibrutinib with moderate or mild inhibitors of CYP3A have not been conducted. Simulations using physiologically-based pharmacokinetic (PBPK) models suggested that moderate CYP3A inhibitors (diltiazem and erythromycin) may increase the AUC of ibrutinib 5 to 8-fold in fasted condition, and that mild CYP3A inhibitors (fluvoxamine and azithromycin) may increase the AUC of ibrutinib less than 2-fold in fasted condition.

In a sequential design trial of 18 healthy volunteers, a single dose of 560 mg of IMBRUVICA[®] was administered alone on Day 1 and on Day 11 in combination with 600 mg of rifampin (given daily on Days 4 to 13). Rifampin (a strong CYP3A inducer) decreased ibrutinib C_{max} and AUC_{last} 13- and 10-fold, respectively. The corresponding decrease in C_{max} and AUC_{last} of the dihydrodiol metabolite was 1.4- and 2.5-fold, respectively. Drug-drug interaction studies of ibrutinib with moderate or mild inducers of CYP3A have not been conducted. Simulations using PBPK models suggested that a moderate CYP3A inducer (efavirenz) and a strong CYP3A inducer (carbamazepine) may decrease the AUC of ibrutinib by up to 3 and 6-fold, respectively.

Ibrutinib has a pH dependent solubility, with lower solubility at higher pH. In 20 fasted healthy subjects, a single dose of 560 mg IMBRUVICA[®] was administered after taking omeprazole (a proton pump inhibitor) at 40 mg once daily for 5 days. Compared with ibrutinib alone, repeated administration of omeprazole at 40 mg (once daily) minimally affected AUC of ibrutinib while C_{max} was reduced by 62.50%. There is no evidence that the lower C_{max} would have clinical significance, and medicinal products that increase stomach pH (e.g., proton pump inhibitors) have been used without restrictions in the pivotal clinical trials.

Ibrutinib did not significantly affect the *in vitro* plasma protein binding of warfarin (bound predominantly to albumin).

In vitro studies indicated that ibrutinib is a weak inhibitor toward CYP2B6, CYP2C8, CYP2C9, CYP2C19, CYP2D6, and CYP3A4/5. The dihydrodiol metabolite of ibrutinib is a weak inhibitor toward CYP2B6, CYP2C8, CYP2C9, and CYP2D6. Both ibrutinib and the dihydrodiol metabolite are at most weak inducers of CYP450 isoenzymes *in vitro*. Inhibition or induction of CYP450 enzymes by ibrutinib, the dihydrodiol metabolite, and other metabolites is unlikely to lead to a clinically relevant drug interaction with drugs that are CYP450 substrates.

In vitro studies indicated that ibrutinib is not a substrate of P-gp nor BCRP, MRP1, OATP1B1, OATP1B3, OATP2B1, OCT1, OAT1 or OAT3, but is a substrate of OCT2. The dihydrodiol

metabolite and other metabolites are P-gp substrates. Administration of ibrutinib with inhibitors of P-gp or other major transporters is unlikely to lead to clinically relevant drug interactions.

Drug-food interactions

In a cross-over design trial of 8 healthy volunteers, 240 mL of grapefruit juice was given the evening before and again 30 minutes before a single dose of 140 mg of IMBRUVICA[®], followed by a standard breakfast 30 minutes after dosing. Grapefruit juice increased ibrutinib dose-normalized C_{max} and AUC_{last} 4 and 2-fold, respectively.

Special Populations and Conditions

Pediatrics (<18 years of age)

The safety, efficacy, and pharmacokinetics of ibrutinib in combination with either the rituximab, ifosfamide, carboplatin, etoposide and dexamethasone (RICE) regimen, or the rituximab, vincristine, ifosfamide, carboplatin, idarubicin, and dexamethasone (RVICI) regimen were explored in Study 54179060LYM3003, a two part study in pediatric and young adult patients (range 3-19 years) with relapsed/refractory mature B-cell non-Hodgkin lymphoma. Results from the randomized part (Part 2) of the study did not show an additional efficacy benefit when ibrutinib was added to RICE or RVICI.

The pharmacokinetics of ibrutinib were explored in the run-in part (Part 1) of this study with sparse PK samples collected on Cycle 1 Day 1, Cycle 1 Day 7 and Cycle 2 Day 1 in 21 pediatric patients aged 3 to 17 years. A population pharmacokinetic (PK) approach was used for pediatric AUC_{0-24h} estimation. As an exposure-response relationship has not been established between ibrutinib PK and a clinical (or surrogate) efficacy endpoint, the effective exposure range in adults is unknown. Systemic exposures in adults at the clinically recommended doses are presented in Table 19.

Based on the population PK analysis, high variability of AUC_{0-24h} was observed. Due to this variability and the limited sample size, no dose-exposure relationship was apparent in any age group. In seven patients aged 12 to 17 years who were administered a 240 or 329 mg/m² daily dose, the estimated mean AUC_{0-24h} values of ibrutinib by dose and by study day ranged from 162 to 745 ng·h/mL (n = 3-5 per dose and study day). In ten patients aged 6 to 11 years who were administered a 240, 329 or 440 mg/m² daily dose, the estimated mean AUC_{0-24h} values ranged from 70 to 399 ng·h/mL (n = 1-5 per dose and study day). In four patients aged 3 to 5 years who were administered a 240, 329 or 440 mg/m² daily dose, the estimated mean AUC_{0-24h} values ranged from 129 to 775 ng·h/mL (n = 1-2 per dose and study day). There were significant reductions (48-74%) of AUC_{0-24h} on Cycle 1 Day 7 when compared to Cycle 1 Day 1 in patients aged 6 to 17 years, for which a cause has not been established.

Geriatrics (≥65 years of age)

Pharmacokinetic data in patients administered 420 mg daily dose showed higher systemic exposures of ibrutinib (25% higher AUC and 50% higher C_{max}) and the dihydrodiol metabolite (48% higher AUC and 56% higher C_{max}) at steady state in patients ≥65 years of age when compared with those <65 years.

Gender

Pharmacokinetic data in patients administered 420 mg daily dose showed approximately 34% higher steady state exposure of the dihydrodiol metabolite in female patients when compared with males whereas ibrutinib exposures were comparable. Population pharmacokinetics data indicated that gender does not significantly affect ibrutinib clearance from the circulation.

Hepatic Impairment

Ibrutinib is metabolized in the liver. In a hepatic impairment trial in non-cancer patients administered a single dose of 140 mg of IMBRUVICA[®], data showed up to 9- and 13-fold increase in exposure of total ibrutinib and unbound ibrutinib, respectively, in subjects with hepatic impairment.

Renal Impairment

No specific clinical studies have been conducted in subjects with impaired renal function. Ibrutinib has minimal renal clearance; urinary excretion of metabolites is <10% of the dose. There are no data in patients with severe renal impairment or patients on dialysis.

STORAGE AND STABILITY

Store at room temperature between 15°C-30°C. Keep out of reach and sight of children.

DOSAGE FORMS, COMPOSITION AND PACKAGING

IMBRUVICA[®] tablets and capsules are formulated for oral administration.

IMBRUVICA[®] (ibrutinib) tablets

140 mg tablets

Yellow-green to green round film-coated tablet debossed with “ibr” on one side and “140” on the other, containing 140 mg of ibrutinib.

280 mg tablets

Purple oblong film-coated tablet debossed with “ibr” on one side and “280” on the other, containing 280 mg of ibrutinib.

420 mg tablets

Yellow-green to green oblong film-coated tablet debossed with “ibr” on one side and “420” on the other, containing 420 mg of ibrutinib.

560 mg tablets

Yellow to orange oblong film-coated tablet debossed with “ibr” on one side and “560” on the other, containing 560 mg of ibrutinib.

Each tablet also contains the inactive ingredients colloidal silicon dioxide, croscarmellose sodium, lactose monohydrate, magnesium stearate, microcrystalline cellulose, povidone, and sodium lauryl sulfate. The tablet film coatings contain black iron oxide (140 mg, 280 mg and 420 mg tablets), polyethylene glycol, polyvinyl alcohol, red iron oxide (280 mg and 560 mg tablets), talc, titanium dioxide, and yellow iron oxide (140 mg, 420 mg and 560 mg tablets).

All strengths of IMBRUVICA[®] tablets are packaged in push-through blisters composed of polyvinyl chloride (PVC) laminated with polychlorotrifluoroethylene (PCTFE) with aluminium foil backing, and are available in cartons of 30 tablets (each carton contains 3 wallets of 10 tablets).

IMBRUVICA[®] (ibrutinib) capsules

140 mg capsules

White hard gelatin capsules marked with “ibr 140 mg” in black ink, containing 140 mg ibrutinib.

Each capsule also contains the following inactive ingredients: croscarmellose sodium, magnesium stearate, microcrystalline cellulose and sodium lauryl sulfate. The white capsule shell contains gelatin and titanium dioxide (E171). Capsules are printed with ink containing iron oxide black (E172) and shellac.

IMBRUVICA[®] capsules are packaged in high-density polyethylene (HDPE) bottles of 90 capsules.

PART II: SCIENTIFIC INFORMATION

PHARMACEUTICAL INFORMATION

Drug Substance

Common name: ibrutinib

Chemical name: 1-[(3R)-3-[4-amino-3-(4-phenoxyphenyl)-1H-pyrazolo[3,4-d]pyrimidin-1-yl]-1-piperidinyl]-2-propen-1-one

Molecular formula and molecular mass: C₂₅H₂₄N₆O₂ and 440.50 g/mol

Structural formula:

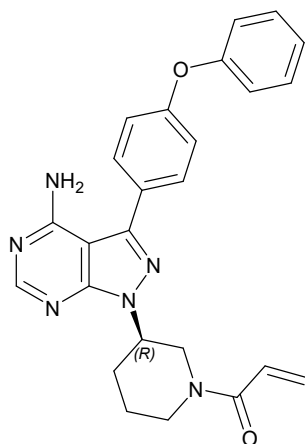

Physicochemical properties:

Appearance: Ibrutinib is a crystalline white to off-white solid.

Solubility: Ibrutinib is practically insoluble in water over a wide pH range (pH 3 to 8).

Dissociation Constant: The drug substance has one ionizable group, the protonated pyrimidine moiety, with a pK_a of 3.74.

CLINICAL TRIALS

Previously Untreated Chronic Lymphocytic Leukemia (CLL)

Single-agent therapy

The efficacy and safety of IMBRUVICA[®] were demonstrated in a multi-center, randomized, controlled, open-label phase 3 trial in patients with previously untreated CLL, including 20 patients with clinical presentation of small lymphocytic lymphoma (SLL) (PCYC-1115-CA).

Patients were eligible for the study if they were 65 years of age or older. Patients between age 65 and 70 years were required to have at least one of the following comorbidities that could preclude the use of chemoimmunotherapy with fludarabine, cyclophosphamide, and rituximab: creatinine clearance <70 mL/min, platelet count <100,000/ μ L or hemoglobin <100 g/L, clinical apparent autoimmune cytopenia, or ECOG performance status score of 1 or 2. Patients (n=269) were randomized 1:1 to receive either IMBRUVICA[®] 420 mg daily until disease progression or unacceptable toxicity, or chlorambucil at a starting dose of 0.5 mg/kg on Days 1 and 15 of each 28-day cycle for a maximum of 12 cycles, with an allowance for inpatient dose increases up to 0.8 mg/kg based on tolerability. After confirmed disease progression, patients on chlorambucil were able to crossover to ibrutinib. The primary endpoint was progression-free survival (PFS) as assessed by independent review committee (IRC). Secondary endpoints included overall response rate (ORR) as assessed by the IRC, overall survival (OS), rate of sustained platelet improvement, and rate of sustained hemoglobin improvement.

The median age was 73 years (range, 65 to 90 years), 63% were male, and 91% were Caucasian. Ninety-one percent of patients had a baseline ECOG performance status of 0 or 1, and 9% had an ECOG performance status of 2. At baseline, 45% of patients had advanced clinical stage (Rai Stage III or IV), 35% had at least one tumour \geq 5 cm, 39% had baseline anemia, 23% had baseline thrombocytopenia, 65% had elevated β 2 microglobulin >3500 μ g/L, 47% had creatinine clearance <60 mL/min, 20% had 11q deletion, and of those with known immunoglobulin heavy chain variable region (IGHV) mutational status (n=200), 59% were unmutated.

At a median follow-up of 18.4 months, PFS as assessed by IRC according to International Workshop on CLL (IWCLL) criteria indicated an 84% statistically significant reduction in the risk of death or progression in the IMBRUVICA[®] arm. Analysis of OS demonstrated an 84% statistically significant reduction in the risk of death for patients in the IMBRUVICA[®] arm. Efficacy results are shown in Table 20 and the Kaplan-Meier curves for PFS and OS are shown in Figure 1 and Figure 2, respectively.

Table 20: Efficacy Results in Study PCYC-1115-CA

Endpoint	IMBRUVICA[®] N=136	Chlorambucil N=133
Progression-Free Survival^a		
Median	Not reached	18.9 months (95% CI: 14.1, 22.0)
Hazard Ratio (HR)	0.16 (95% CI: 0.091, 0.28); p<0.0001	
Overall Response Rate^{a,b}		
CR+PR	82.4%	35.3%
P-value	p<0.0001	
Overall Survival		
Median	Not reached	Not reached
HR	0.16 (95% CI: 0.048, 0.56); p<0.005	

^a Per IRC.

^b Repeat CT scans required to confirm response.

Figure 1: Kaplan-Meier Curve of Progression-Free Survival (ITT Population) in Study PCYC-1115-CA

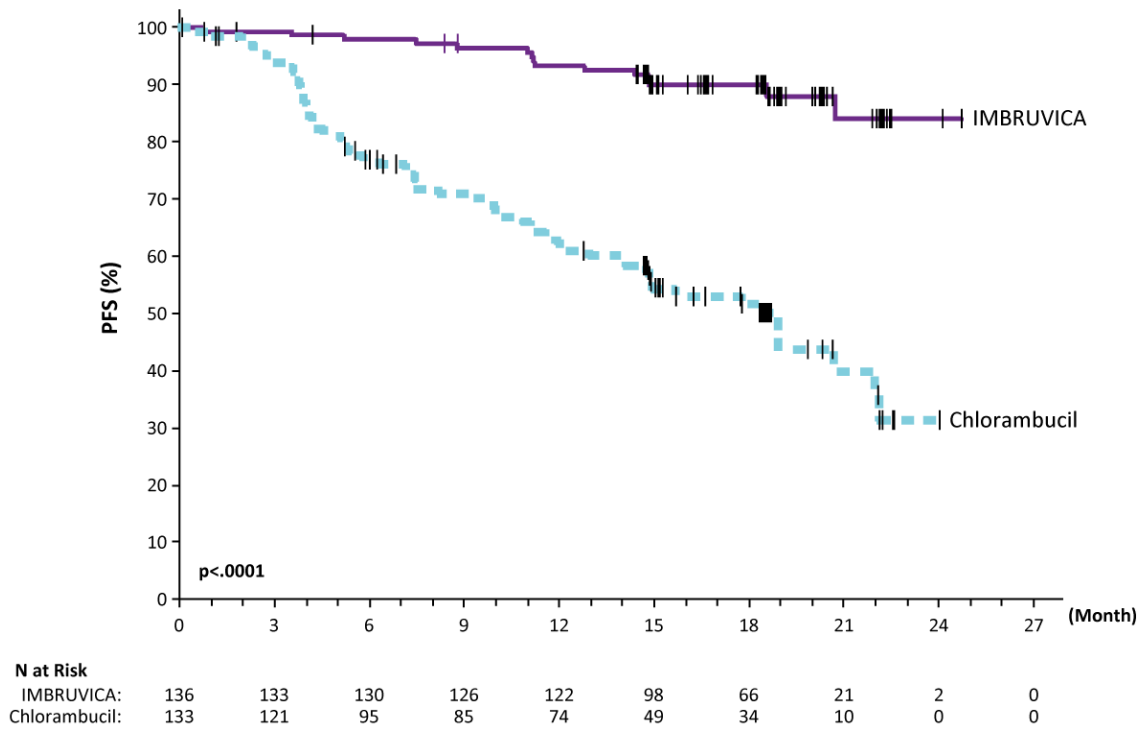
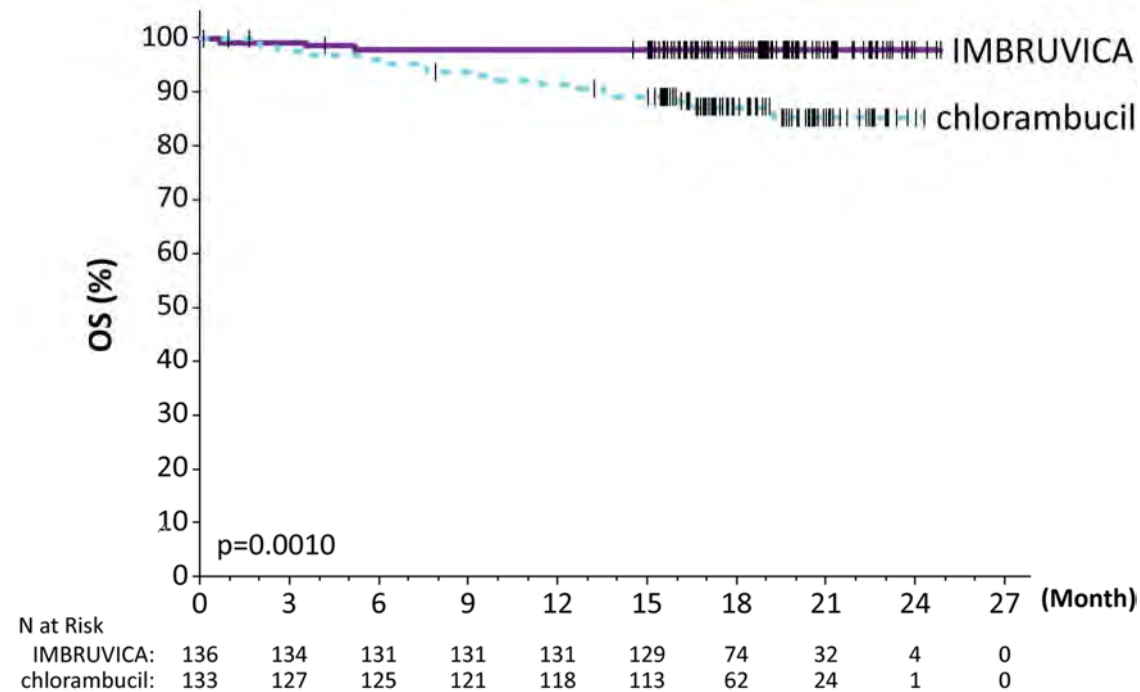

Figure 2: Kaplan-Meier Curve of Overall Survival (ITT Population) in Study PCYC-1115-CA



The PFS was similar across subgroups examined, including in patients with and without advanced disease (Rai stage 0-II and stage III-IV; a pre-specified stratification factor), patients with ECOG performance status 0-1 and 2; a pre-specified stratification factor), patients age <math>< 70</math>

years and ≥ 70 years, patients with and without bulky lymphadenopathy (< 5 cm and ≥ 5 cm), patients with and without cytopenias at baseline, patients with and without deletion 11q, patients with unmutated and mutated IGHV, and patients with baseline $\beta 2$ -microglobulin ≤ 3.5 mg/mL and > 3.5 mg/mL.

In the intent-to-treat population, a significantly greater proportion of patients exhibited sustained improvement in platelets or hemoglobin in the IMBRUVICA[®] arm than in the chlorambucil arm (platelets, 27% versus 11%, $p=0.0009$; hemoglobin, 46% versus 20%, $p<0.0001$). In patients with baseline cytopenias, a significantly greater proportion of patients in the IMBRUVICA[®] arm exhibited sustained hematologic improvement than in the chlorambucil arm (platelets, 77% versus 43%, $p=0.0054$; hemoglobin, 84% versus 46%, $p<0.0001$).

With a median follow-up of 48 months (overall follow-up of 55 months) in Study PCYC-1115-CA and its extension study, the median investigator-assessed PFS was not reached in the IMBRUVICA[®] arm and was 15 months [95% CI (10.22, 19.35)] in the chlorambucil arm; (HR = 0.14 [95% CI (0.090, 0.21)]). The 4-year PFS estimate was 73.9% in the IMBRUVICA[®] arm and 15.5% in the chlorambucil arm, respectively. The Kaplan-Meier landmark estimate for OS at 48-months was 85.5% in the IMBRUVICA[®] arm and 75.6% in the chlorambucil arm, irrespective of 54.9% of patients who crossed over from the chlorambucil arm to receive ibrutinib treatment.

Combination therapy

The efficacy and safety of IMBRUVICA[®] in combination with obinutuzumab in patients with previously untreated CLL were demonstrated in a randomized controlled trial (PCYC-1130-CA).

PCYC-1130-CA was a randomized, multi-center, open-label, controlled phase 3 study of IMBRUVICA[®] in combination with obinutuzumab versus chlorambucil in combination with obinutuzumab conducted in patients with previously untreated CLL, including 15 with clinical presentation of SLL. The study enrolled patients who were ≥ 65 years of age or who were < 65 years of age with coexisting medical conditions, reduced renal function as measured by creatinine clearance < 70 mL/min, or 17p deletion/tumour protein 53 (TP53) mutation. Patients ($n=229$) were randomized 1:1 to receive either IMBRUVICA[®] 420 mg daily until disease progression or unacceptable toxicity or chlorambucil at a dose of 0.5 mg/kg on Days 1 and 15 of each 28-day cycle for 6 cycles. In both arms, patients received 1000 mg of obinutuzumab on Days 1, 8 and 15 of the first cycle, followed by treatment on the first day of 5 subsequent cycles (total of 6 cycles, 28 days each). The first dose of obinutuzumab was divided between day 1 (100 mg) and day 2 (900 mg). The primary endpoint was progression-free survival (PFS) as assessed by an independent review committee (IRC) according to the International Workshop on CLL (IWCLL) criteria. After IRC-confirmed disease progression, patients in the chlorambucil + obinutuzumab arm may cross-over to receive next-line ibrutinib monotherapy.

The median age was 71 years (range, 40 to 87 years), 64% were male, and 96% were Caucasian. All patients had a baseline ECOG performance status of 0 (48%) or 1-2 (52%). At baseline, 52% had advanced clinical stage (Rai Stage III or IV), 32% of patients had bulky disease (≥ 5 cm), 44% with baseline anemia, 22% with baseline thrombocytopenia, 28% had a CrCL < 60 mL/min, and the median Cumulative Illness Rating Score for Geriatrics (CIRS-G) was 4 (range, 0 to 12). At baseline, 18% of patients had 17p deletion/TP53 mutation, 15% had 11q deletion, and of those with known IGHV mutational status ($n=214$), 57% were unmutated.

Progression-free survival (PFS) as assessed by IRC indicated a statistically significant reduction of 77% in the risk of death or progression in the IMBRUVICA® arm. With a median follow-up time on study of 31 months, the median PFS was not reached in the IMBRUVICA® + obinutuzumab arm and was 19 months in the chlorambucil + obinutuzumab arm. Efficacy results for Study PCYC-1130-CA are shown in Table 21 and the Kaplan-Meier curve for PFS is shown in Figure 3.

Table 21: Efficacy results in Study PCYC-1130-CA

Endpoint	IMBRUVICA® + Obinutuzumab N=113	Chlorambucil + Obinutuzumab N=116
Progression Free Survival^a		
Number of events (%)	24 (21.2)	74 (63.8)
Median (95% CI), months	Not reached	19.0 (15.1, 22.1)
HR (95% CI)	0.23 (0.15, 0.37)	
Overall Response Rate^a (%)	88.5	73.3
CR ^b	19.5	7.8
PR ^c	69.0	65.5

CI = confidence interval; HR = hazard ratio; CR = complete response; CRi = complete response with incomplete marrow recovery; PR = partial response; nPR = nodular partial response. Overall Response Rate = CR+ CRi + nPR + PR

^a IRC evaluated.

^b Includes 1 patient in the IMBRUVICA® + obinutuzumab arm with CRi.

^c PR = PR + nPR.

Figure 3: Kaplan-Meier Curve of Progression-Free Survival (ITT Population) in Study PCYC-1130-CA

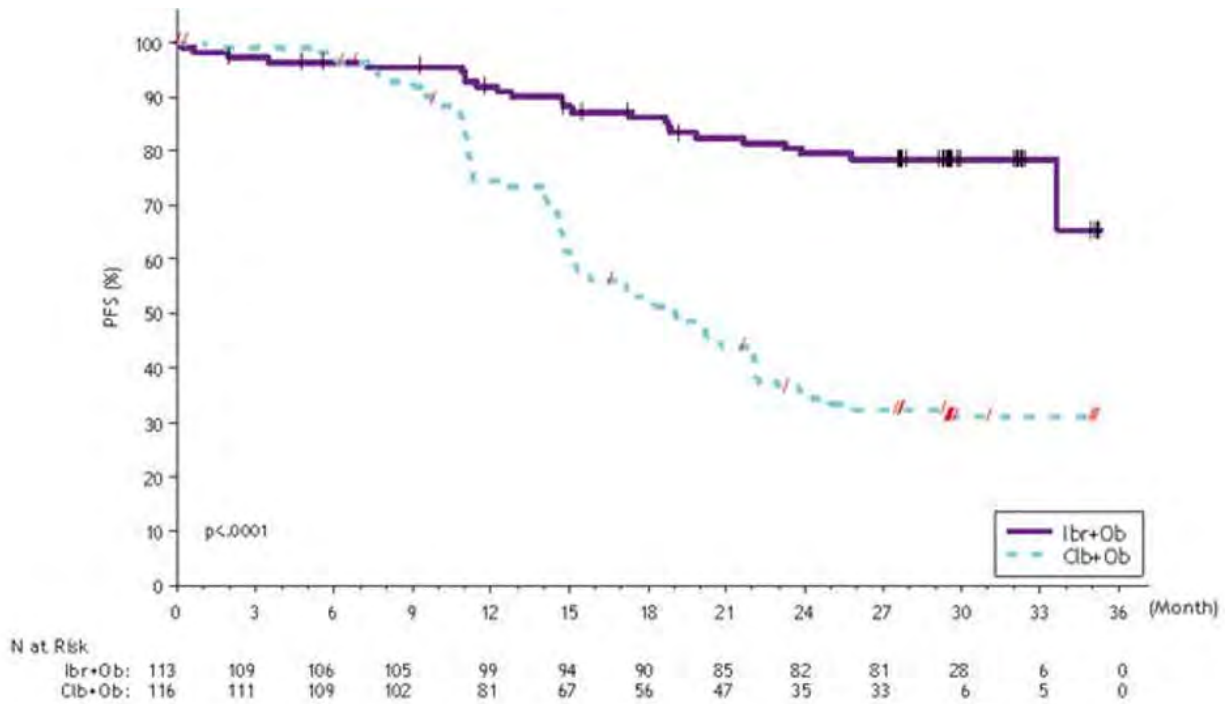

In the high-risk population (patients with any of 17p deletion/TP53 mutation, 11q deletion or unmutated IGHV) the PFS HR was 0.15 [95%CI (0.09, 0.27)], which is consistent with other

subgroups examined. In this population, the median PFS was not reached in the IMBRUVICA[®] + obinutuzumab and was 14.7 months for the chlorambucil + obinutuzumab arm.

PFS was similar across all subgroups examined, including patients <65 and ≥ 65 years of age, patients with and without 17p deletion/TP53 mutation, patients with and without 11q deletion, patients with mutated and unmutated IGHV, patients with and without advanced disease (Rai stage 0-II and stage III-IV), patients with and without bulky lymphadenopathy (<5cm and ≥5cm), and patients with and without functional impairment (ECOG performance status 0 and 1-2).

Previously Treated Chronic Lymphocytic Leukemia (CLL)

Single-agent therapy

The safety and efficacy of IMBRUVICA[®] in patients with CLL who have received at least one prior therapy were demonstrated in one randomized, controlled trial (PCYC-1112-CA), and one uncontrolled trial (PCYC-1102-CA).

Study PCYC-1112-CA was a randomized, multi-center, open-label phase 3 study of IMBRUVICA[®] versus ofatumumab conducted in patients with previously treated CLL, including 18 patients with clinical presentation of SLL. Patients were eligible for the study if they failed to respond to prior therapy, relapsed following a response to prior therapy, or otherwise met the 2008 IWCLL criteria for active disease requiring treatment following at least one prior therapy, and were not appropriate for treatment or retreatment with purine analog. Patients (n=391) were randomized 1:1 to receive either IMBRUVICA[®] 420 mg daily until disease progression or unacceptable toxicity, or ofatumumab for up to 12 doses (300/2000 mg). Fifty-seven patients randomized to ofatumumab crossed over following progression to receive IMBRUVICA[®]. The median age was 67 years (range, 30 to 88 years), 68% were male, and 90% were Caucasian. All patients had a baseline ECOG performance status of 0 or 1. The median time since diagnosis was 91 months and the median number of prior treatments was 2 (range, 1 to 13 treatments). At baseline, 58% of patients had at least one tumour ≥5 cm. Thirty-two percent of patients had 17p deletion, 50% had 17p deletion/TP53 mutation, 31% had 11q deletion, and of those with known IGHV mutational status (n= 266), 68% were unmutated.

At a median duration of follow-up of 9.6 months in the ibrutinib arm and 9.2 months in the ofatumumab arm, PFS as assessed by IRC according to 2008 IWCLL criteria indicated a 78% statistically significant reduction in the risk of death or progression for patients in the IMBRUVICA[®] arm. Analysis of OS demonstrated a 57% statistically significant reduction in the risk of death for patients in the IMBRUVICA[®] arm. Efficacy results are shown in Table 22 and the Kaplan-Meier curves for PFS and OS are shown in Figure 5 and Figure 6, respectively.

Table 22: Efficacy results in patients with Chronic Lymphocytic Leukemia (Study PCYC-1112-CA)

Endpoint	IMBRUVICA® N=195	Ofatumumab N=196
Median Progression Free Survival	Not reached	8.1 months
	HR=0.22 [95% CI: 0.15; 0.32]	
Overall Survival ^a	HR=0.43 [95% CI: 0.24; 0.79] ^b HR=0.39 [95% CI: 0.22; 0.70] ^c	
Overall Response Rate ^{d,e}	42.6%	4.1%
Overall Response Rate with PRL ^d	62.6%	4.1%

^a Median OS not reached for both arms.

^b Patients randomized to ofatumumab who progressed were censored when starting ibrutinib if applicable.

^c Sensitivity analysis in which crossover patients from the ofatumumab arm were not censored at the date of first dose of IMBRUVICA®.

^d Per IRC. Repeat CT scans required to confirm response.

^e All PRs achieved; none of the patients achieved a CR. p<0.0001 for ORR.

The efficacy was similar across all of the subgroups examined, including in patients with and without 17p deletion (a pre-specified stratification factor), patients with and without deletion 11q, patients with unmutated and mutated IGHV (not pre-specified subgroups), patients refractory and not refractory to prior purine analog treatment, patients with and without advanced disease (Rai stage 0-II and stage III-IV), and patients with and without bulky lymphadenopathy (<5 cm and ≥5 cm) (Figure 4).

Figure 4: Subgroup Analysis of Progression-Free Survival by IRC (Study PCYC-1112-CA; 420 mg)

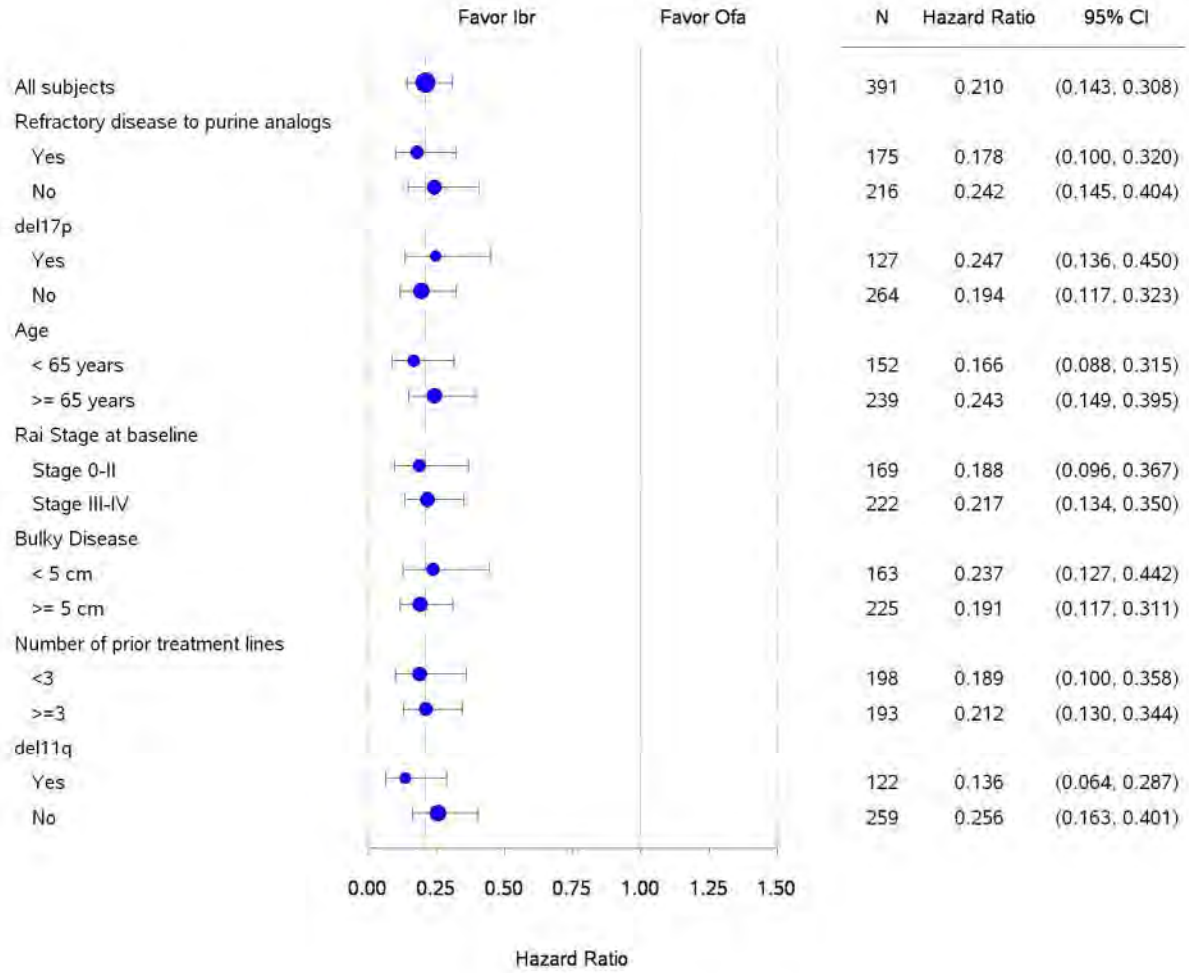

Figure 5: Kaplan-Meier Curve of Progression-Free Survival (ITT Population) in Study PCYC-1112-CA

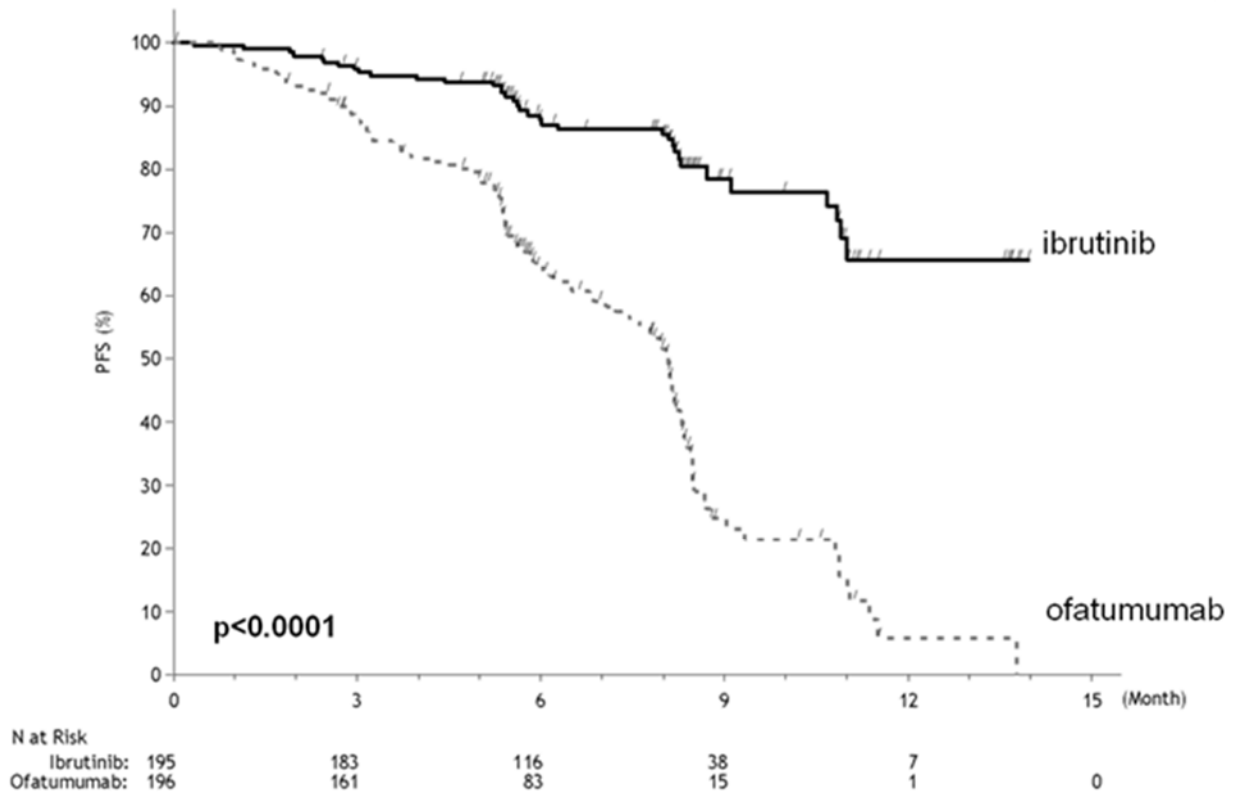
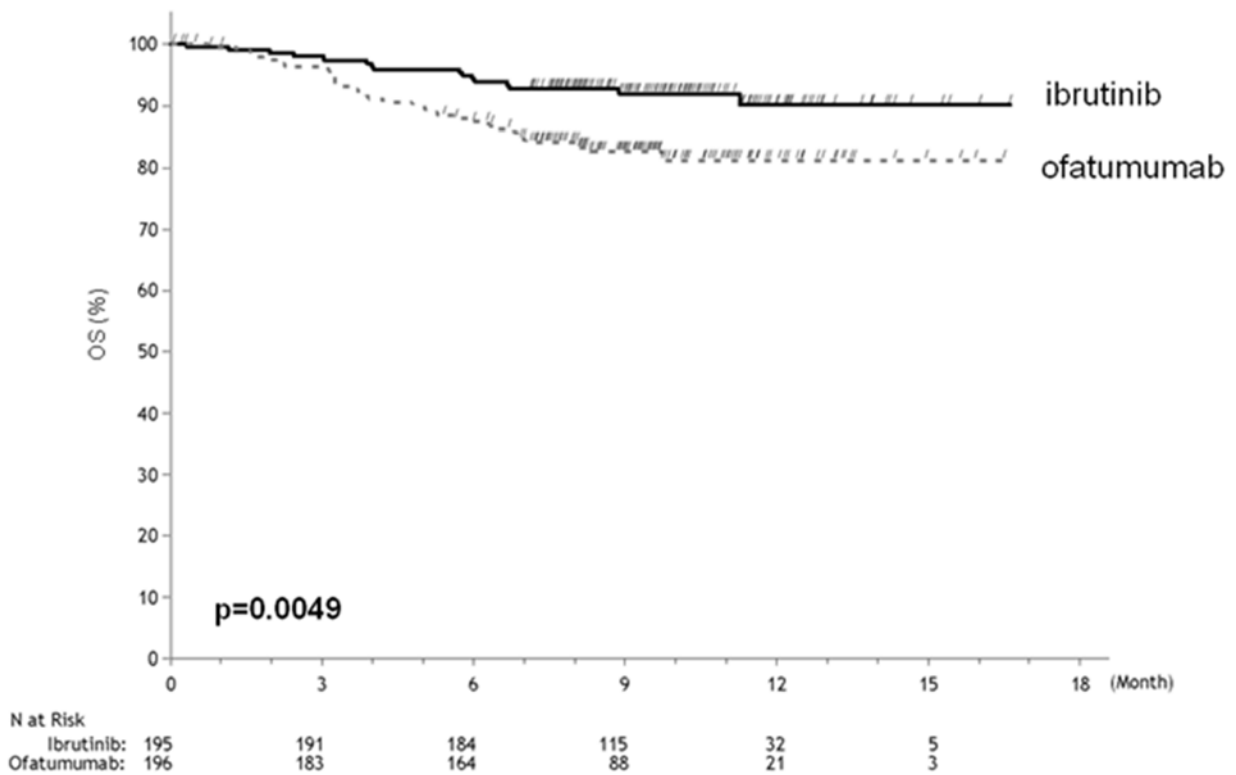

Figure 6: Kaplan-Meier Curve of Overall Survival (ITT Population) in Study PCYC-1112-CA



At a median follow-up of 55.9 months (overall follow-up of 63 months), the median investigator-assessed PFS according to IWCLL criteria was 44.1 months [95% CI (38.54, 56.87)] in the IMBRUVICA® arm and 8.1 months [95% CI (7.79, 8.25)] in the ofatumumab arm (HR=0.14; 95% CI: 0.11, 0.19). The Kaplan-Meier landmark estimate for OS at 60-months was 62.2% in the IMBRUVICA® arm and 54.8% in the ofatumumab arm, irrespective of 67.9% of subjects who crossed over from the ofatumumab arm to receive ibrutinib treatment. The ORR (per investigator) was 87% in the IMBRUVICA® arm versus 22.4% in the ofatumumab arm.

Study PCYC-1102-CA was an open-label, multi-center study conducted in 51 patients with relapsed or refractory CLL who have failed at least 1 prior therapy, including 3 patients with clinical presentation of SLL. Patient demographics and baseline characteristics were similar to those of patients in Study PCYC-1112-CA. At a median duration of follow-up of 16.4 months, response rates (ORR and ORR with PRL) were similar to response rates observed in Study PCYC-1112-CA. Median (range) time to initial response was 1.8 months (1.4 to 12.2 months).

Study PCYC-1112-CA included 127 patients with CLL with 17p deletion. The median age was 67 years (range, 30 to 84 years), 62% were male, and 88% were Caucasian. All patients had a baseline ECOG performance status of 0 or 1. PFS and ORR were assessed by IRC. Efficacy results for CLL with 17p deletion are shown in Table 23.

Table 23: Efficacy results in patients with CLL with 17p deletion (Study PCYC-1112-CA)

Endpoint	IMBRUVICA® N=63	Ofatumumab N=64
Median Progression Free Survival	Not reached	5.8 months
	HR=0.25 [95% CI: 0.14; 0.45]	
Overall Response Rate ^a	47.6%	4.7%
Overall Response Rate with PRL	66.7%	4.7%

^a IRC evaluated. All partial responses achieved; none of the patients achieved a complete response. HR=hazard ratio.

With a median follow-up of 56.3 months in Study PCYC-1112-CA (overall follow-up of 63 months), the median investigator-assessed PFS in patients with 17p deletion according to IWCLL criteria was 40.6 months [95% CI (25.36, 44.55)] in the IMBRUVICA® arm and 6.2 months [95% CI (4.63, 8.11)] in the ofatumumab arm, respectively; HR = 0.12, ([95% CI (0.074, 0.21)]. The investigator-assessed ORR in patients with 17p deletion in the IMBRUVICA® arm was 88.9% versus 18.8% in the ofatumumab arm.

Combination therapy

The safety and efficacy of IMBRUVICA® in combination with BR in patients with previously treated CLL were demonstrated in a randomized, controlled trial (CLL3001).

CLL3001 was a randomized, multi-center, double-blind, placebo-controlled phase 3 study of IMBRUVICA® in combination with BR versus placebo in combination with BR was conducted in patients with previously treated CLL without 17p deletion, including 64 patients with clinical presentation of SLL. Patients (n=578) were randomized 1:1 to receive either IMBRUVICA® 420 mg daily or placebo in combination with BR until disease progression or unacceptable toxicity.

Patients received BR for a maximum of six 28-day cycles. Bendamustine was dosed at 70 mg/m² infused IV over 30 minutes on Cycle 1 (Days 2 and 3) and on Cycles 2-6 (Days 1 and 2) for up to 6 cycles. Rituximab was administered at a dose of 375 mg/m² in the first cycle (Day 1), and 500 mg/m² Cycles 2 through 6 (Day 1). Ninety patients randomized to placebo in combination with BR crossed over to receive IMBRUVICA[®] following IRC-confirmed disease progression. The median age was 64 years (range, 31 to 86 years), 66% were male, and 91% were Caucasian. All patients had a baseline ECOG performance status of 0 or 1. The median time since diagnosis was 5.9 years and the median number of prior treatments was 2 (range, 1 to 11 treatments). At baseline, 56% of patients had at least one tumour \geq 5 cm, 26% had 11q deletion, and of those with known IGHV mutational status (n=519), 81% were unmutated.

At a median duration of treatment of 14.7 months in the IMBRUVICA[®] in combination with BR arm, and 12.8 months in the placebo in combination with BR arm, PFS as assessed by IRC according to IWCLL criteria indicated a statistically significant, 80% reduction in the risk of death or progression. Efficacy results for Study CLL3001 are shown in Table 24 and the Kaplan-Meier curve for PFS is shown in Figure 7.

Table 24: Efficacy results in patients with CLL treated with IMBRUVICA[®] in combination with BR (Study CLL3001)

Endpoint	IMBRUVICA[®]+BR N=289	Placebo+BR N=289
Median Progression Free Survival	Not reached	13.3 months
	HR=0.20 [95% CI: 0.15; 0.28]	
Overall Response Rate*	82.7%	67.8%
Overall Response Rate with PRL	83.4%	67.8%

* Per IRC, ORR (CR, CRi, nPR, PR)

The efficacy was similar across all of the subgroups examined, including in patients with and without deletion 11q, patients with unmutated and mutated IGHV, patients refractory and not refractory to prior purine analog treatment, patients with and without advanced disease (Rai stage 0-II and stage III-IV), patients with and without bulky lymphadenopathy (<5 cm and \geq 5 cm), patients <65 or \geq 65 years of age, and patients with 1 or >1 prior lines of therapy.

Figure 7: Kaplan-Meier Curve of Progression-Free Survival (ITT Population) in Study CLL3001

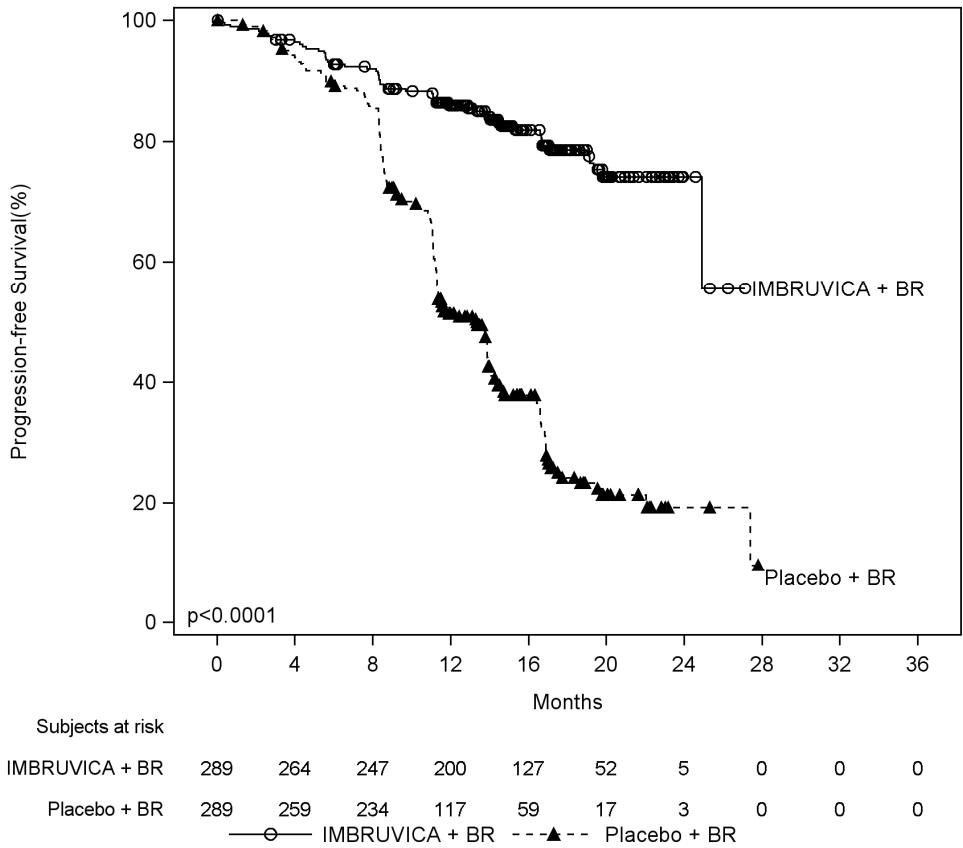

Mantle Cell Lymphoma (MCL)

The safety and efficacy of IMBRUVICA[®] in patients with relapsed or refractory MCL were demonstrated in a single-arm, multicenter phase 2 trial (PCYC-1104-CA). The patients studied received at least 1, but no more than 5, prior treatment regimens for MCL, and had documented failure to achieve at least partial response with, or documented disease progression after, the most recent treatment regimen. The median age was 68 years (range, 40 to 84 years), 77% were male and 92% were Caucasian. The median time since diagnosis was 42 months, and median number of prior treatments was 3 (range, 1 to 5 treatments). At baseline, 39% of patients had bulky disease (≥ 5 cm), 49% had high-risk score by Simplified MCL International Prognostic Index (MIPI), 72% had advanced disease (extranodal and/or bone marrow involvement), and 15% had blastoid histology at screening.

IMBRUVICA[®] was administered orally at 560 mg once daily until disease progression or unacceptable toxicity. Tumour response was assessed according to the revised International Working Group (IWG) for non-Hodgkin’s lymphoma (NHL) criteria. The primary endpoint in this study was investigator-assessed overall response rate (ORR). At a median duration of follow up of 26.7 months, responses to IMBRUVICA[®] are shown in Table 25.

Table 25: Overall Response Rate (ORR) Based on Investigator Assessment in Patients with Mantle Cell Lymphoma (Study PCYC-1104-CA; n=111)

ORR (CR+PR) (95% CI)	66.7% (57.1%, 75.3%)
CR	22.5%
PR	44.1%

CI = confidence interval; CR = complete response; PR = partial response; NR = not reached

The median time to initial response was 1.9 months, and the median duration of response (DOR) was estimated to be 17.5 months. The efficacy data were further evaluated by an IRC demonstrating an ORR of 69%, with a 25% CR rate and a 43% PR rate.

The overall response to IMBRUVICA® appears to be independent of prior treatment (bortezomib, lenalidomide), prognostic factors, bulky disease, blastoid histology, gender, and age.

Marginal zone lymphoma (MZL)

The safety and efficacy of IMBRUVICA® were evaluated in a multicenter, single arm phase 2 study (PCYC-1121) of patients with MZL who received at least one prior line of systemic therapy, including an anti-CD20-based therapy. The efficacy analysis included 60 patients with 3 sub types of MZL: mucosa-associated lymphoid tissue (MALT; n=30), nodal (n=17), and splenic (n=13). The median age was 66 years (range, 30 to 92 years), 57% were female, and 85% were Caucasian. Ninety two percent of patients had a baseline ECOG performance status of 0 or 1 and 8% had a status of 2. The median time since diagnosis was 3.7 years and the median number of prior treatments was 2 (range, 1 to 9 treatments).

IMBRUVICA® was administered orally at 560 mg once daily until disease progression or unacceptable toxicity. The primary endpoint in this study was overall response rate (ORR) per independent review committee (IRC) assessment according to revised International Working Group (IWG) criteria for non-Hodgkin’s lymphoma (NHL). Responses to IMBRUVICA® are shown in Table 26.

Table 26: Overall response rate (ORR) and duration of response (DOR) based on IRC assessment in patients with MZL

	Total (N=60)*
ORR (CR +PR) (%)	48.3
95% CI (%)	(35.3, 61.7)
Complete Response (CR) (%)	3.3
Partial Response (PR) (%)	45.0
Median DOR, months (range)	NR (16.7, NR)

*Efficacy Population: all patients who had measurable disease at baseline per IRC assessment, received at least 1 dose of IMBRUVICA®, and had at least 1 adequate post-baseline disease assessment

CI = confidence interval; NR = not reached

Median follow up of 19.4 months.

The median time to initial response was 4.5 months (range, 2.3 to 16.4 months). Per IRC assessment, the median DOR was not reached (range, 16.7 to not reached), with 62% of all responders alive and progression-free at 18 months. The overall response to IMBRUVICA® appears to be consistent among the subgroups examined, including MZL subtypes, number of

prior regimens (1, 2, >=3), presence or absence of extranodal disease, bone marrow involvement (positive, negative), baseline ECOG (0, >=1), gender and age.

Waldenström’s Macroglobulinemia (WM)

Single-Agent Therapy

The safety and efficacy of IMBRUVICA® in patients with WM (IgM-excreting lymphoplasmacytic lymphoma) were evaluated in a single arm trial (PCYC-1118E) and a non-randomized single-agent therapy substudy arm (Study PCYC-1127-CA).

Study PCYC-1118E was an open-label, multi-center, single-arm trial of 63 previously treated patients with WM. The median age was 63 years (range, 44 to 86 years), 76% were male, and 95% were Caucasian. All patients had a baseline ECOG performance of 0 or 1. The median time since diagnosis was 74 months, and the median number of prior treatments was 2 (range, 1 to 11 treatments). At baseline, the median serum IgM value was 3.5 g/dL (range, 0.7 to 8.4 g/dL), the median β 2 microglobulin value was 3.9 mg/L (range, 1.4 to 14.2 mg/L), and 60% of patients were anemic (hemoglobin \leq 110 g/L).

IMBRUVICA® was administered orally as a single-agent therapy at 420 mg once daily until disease progression or unacceptable toxicity. The primary endpoint in this study was ORR, defined as minor response or better (where minor response was categorized by \geq 25-49% reduction in serum monoclonal IgM levels), per investigator assessment. The ORR and duration of response were assessed using criteria adopted from the Third International Workshop of Waldenström’s Macroglobulinemia (IWWM). At a median duration of follow-up of 14.8 months, the ORR per investigator assessment was 87.3% (Table 27). Efficacy results were also assessed by an IRC demonstrating an ORR of 82.5% (Table 27).

Table 27: Overall Response Rate (ORR) and Duration of Response (DOR) Based on Investigator and IRC Assessment in Patients with Waldenström’s Macroglobulinemia (Study PCYC-1118E; n=63)

Endpoint	Investigator	IRC
ORR (95% CI)	87.3% (76.5%, 94.4%) ^a	82.5% (70.9%, 90.9%)
CR	0%	0%
VGPR	14.3%	11.1%
PR	55.6%	50.8%
MR	17.5%	20.6%
Median DOR, months (range)	NR (0.03+, 18.8+) ^b	NR (2.43, 18.8+)
Median time to response, months (range)	1.0 (0.7, 13.4) ^b	1.0 (0.7, 13.4)

^a primary endpoint; ^b secondary endpoint. CI = confidence interval; MR = minor response; NR = not reached; PR = partial response; VGPR = very good partial response; ORR = MR+PR+VGPR.

The overall response to IMBRUVICA® was consistent among all subgroups examined, including number of prior regimens (1-2 and >2), baseline ECOG, hemoglobin level at baseline (\leq 110 g/L and >110 g/L), IgM level at baseline (<40 g/L and \geq 40 g/L), and β 2-microglobulin level at baseline (\leq 3 mg/L and >3 mg/L), gender and age.

The non-randomized single-agent therapy substudy arm of Study PCYC-1127-CA included 31 patients with previously treated WM who failed prior rituximab-containing therapy and received single agent IMBRUVICA®. The median age was 67 years (range, 47 to 90 years). Eighty-one percent of patients had a baseline ECOG performance status of 0 or 1, and 19% had a baseline ECOG performance status of 2. The median number of prior treatments was 4 (range, 1 to 7 treatments). The overall response rate appeared to be consistent with PCYC-1118E.

Combination Therapy

The safety and efficacy of IMBRUVICA® in combination with rituximab were evaluated in a randomized, double-blind, multi-center, controlled phase 3 study (PCYC-1127-CA) in patients with previously untreated and previously treated WM. Patients (n=150) were randomized 1:1 to receive either IMBRUVICA® 420 mg once daily in combination with rituximab or placebo plus rituximab until disease progression or unacceptable toxicity. Intravenous rituximab was administered weekly at a dose of 375 mg/m² for 4 consecutive weeks (weeks 1-4) followed by a second course of weekly rituximab for 4 consecutive weeks (weeks 17-20).

The median age was 69 years (range, 36 to 89 years), 66% were male, and 79% were Caucasian. Ninety-three percent of patients had a baseline ECOG performance status of 0 or 1, and 7% of patients had a baseline ECOG performance status of 2. Forty-five percent of patients were previously untreated, and 55% of patients were previously treated. The median time since diagnosis was 52.6 months (previously untreated patients = 6.5 months and previously treated patients = 94.3 months). Among previously treated patients, the median number of prior treatments was 2 (range, 1 to 6 treatments). At baseline, the median serum IgM value was 3.2 g/dL (range, 0.6 to 8.3 g/dL), the median β 2 microglobulin value was 3.7 mg/L (range, 1.4 to 27.9 mg/L), 63% of patients were anemic (hemoglobin \leq 11 g/dL), MYD88 L265P mutations were present in 77% of patients and absent in 13% of patients, CXCR4 WHIM (warts, hypogammaglobulinemia, infections, myelokathexis) mutations were present in 33% of patients and absent in 58% of patients, and 9% of patients were not evaluable for MYD88 or CXCR4 mutation status. Both MYD88 L265P and CXCR4 WHIM mutations were absent in 13% of patients.

The primary endpoint was PFS as assessed by an IRC, and efficacy evaluations were based on the modified Consensus Response Criteria from the Sixth IWWM. Efficacy results for Study PCYC-1127-CA at a median time on study of 26.5 months are shown in Table 28 and the Kaplan-Meier curve for PFS is shown in Figure 8.

Table 28: Efficacy results of Overall Population of patients with WM based on IRC assessment (Study PCYC-1127-CA)

Endpoint	IMBRUVICA® + Rituximab N=75	Placebo + Rituximab N=75
Progression Free Survival^a		
Number of events	14 (18.7%)	42 (56.0%)
Median, months	Not reached (35.0, NE)	20.3 (95% CI: 13.7, 27.6)
HR	0.20 (95% CI: 0.11, 0.38) p < 0.0001	
Response Rate (CR, VGPR, PR)^b	54 (72.0%)	24 (32.0%)
Rate Ratio	2.299 (95% CI: 1.592, 3.319) p<0.0001	

Median duration of response, months (range)	Not reached (1.9+, 36.4+)	21.2 (4.6, 25.8)
Clinical Response Rate (CR, VGPR, PR, MR)^b	69 (92.0%)	35 (46.7%)
Rate ratio	2.001 (95% CI: 1.554, 2.576) p<0.0001	
CR	2 (2.7%)	1 (1.3%)
VGPR	17 (22.7%)	3 (4.0%)
PR	35 (46.7%)	20 (26.7%)
MR	15 (20.0%)	11 (14.7%)

CI = confidence interval; CR = complete response; HR = hazard ratio; MR = minor response; NE = not estimable; PR = partial response; VGPR = very good partial response

^a Per IRC.

^b p-value associated with response rate was <0.0001.

The median duration of clinical response was not reached in the IMBRUVICA[®]+rituximab arm, and was 24.8 months in the placebo + rituximab arm. The proportion of patients with sustained hemoglobin improvement (defined as increase of ≥ 2 g/dL over baseline regardless of baseline value, or an increase to >11 g/dL with a ≥ 0.5 g/dL improvement if baseline was ≤ 11 g/dL) was 73.3% in the IMBRUVICA[®]+rituximab arm, and 41.3% in the placebo +rituximab arm, rate ratio = 1.774 (95% CI: 1.311, 2.400), p < 0.0001.

Figure 8: Kaplan-Meier Curve of Progression-Free Survival (ITT Population) in Study PCYC-1127-CA

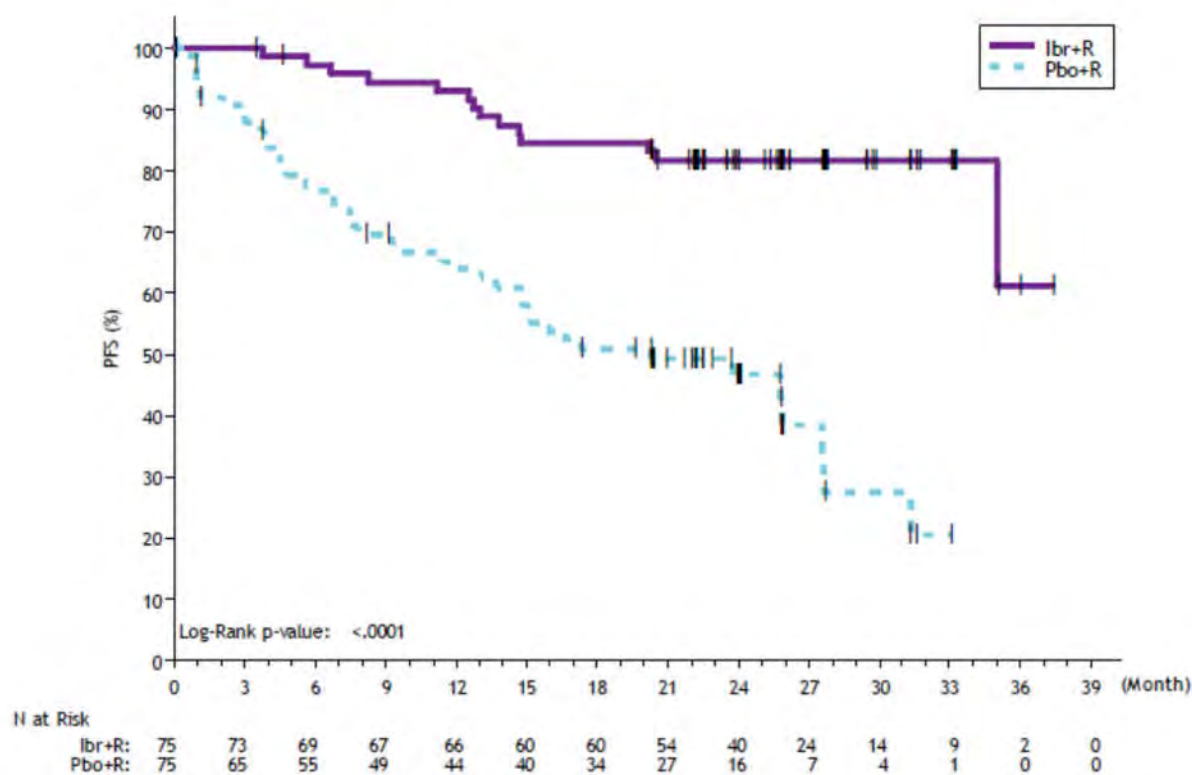

Tumour flare in the form of IgM increase occurred in 8.0% of patients in the IMBRUVICA[®] + rituximab arm and 46.7% of patients in the placebo + rituximab arm.

The PFS hazard ratios for previously untreated and previously treated patients were 0.337 (95% CI: 0.120, 0.948) and 0.165 (95% CI: 0.075, 0.363), respectively. A treatment effect in favour of the IMBRUVICA® + rituximab arm was observed for subgroups examined, including patients with and without MYD88 L265P mutations, gender, and age (<65 and ≥65).

Chronic graft versus host disease (cGVHD)

The safety and efficacy of IMBRUVICA® in cGVHD were evaluated in an open-label, multi-center, single-arm trial of 42 patients with cGVHD who required additional therapy after failure of first line corticosteroid therapy (Study PCYC-1129-CA). The median age was 56 years (range, 19 to 74 years), 52% were male, 93% were Caucasian, and 60% of patients had a Karnofsky performance score of ≤ 80. The most common underlying malignancies leading to transplant were acute lymphocytic leukemia, acute myeloid leukemia, and CLL. The median time since diagnosis was 14 months and the median number of prior cGVHD treatments was 2 (range, 1 to 3 treatments). The majority of patients (88%) had at least 2 organs involved at baseline, with the most commonly involved organs being mouth (86%), skin (81%), and gastrointestinal tract (33%). The median daily steroid dose per body weight at baseline was 0.3 mg/kg/day and 52% of patients were receiving ongoing immunosuppressants in addition to systemic corticosteroids at baseline. Median duration of exposure was 4.4 months (range 0.2 to 14.9; mean 6.6 months) and 12 patients (28.6%) remained on treatment at the time of analysis.

IMBRUVICA® was administered orally at 420 mg once daily until disease progression, unacceptable toxicity or recurrence of underlying malignancy. The primary endpoint in this study was best ORR per investigator assessment using the 2005 National Institutes of Health (NIH) Consensus Panel Response Criteria, with two modifications based on the updated 2014 NIH Consensus Panel Response Criteria. At a median duration of follow-up of 13.9 months the best ORR was 66.7%. Responses were seen across involved organs for cGVHD (skin, mouth, gastrointestinal tract, and liver). The rate of sustained response for ≥ 20 weeks was 71% for responders. The median steroid dose was reduced over time for the all-treated population, from 0.31 mg/kg/day at baseline to 0.14 mg/kg/day at week 48, and 5 patients were able to completely discontinue corticosteroids while in response. Two patients who responded discontinued ibrutinib treatment because their condition no longer required treatment. Exploratory analyses of patient-reported symptom bother showed a decrease of at least 7 points in the Lee Chronic GVHD Symptom Scale total summary score in 43% (18/42) of patients, and in 24% (10/42) of patients on at least 2 consecutive visits. Efficacy results are shown in Table 29.

Table 29: Best overall response rate (ORR), sustained response rate, based on investigator assessment in patients with cGVHD

	Total (N=42)
ORR (%)	66.7
95% CI (%)	(50.5, 80.4)
Complete response (CR) (%)	21.4
Partial response (PR) (%)	45.2
Sustained response rate* (%)	71.4

CI = confidence interval

* Sustained response rate is defined as the proportion of patients who achieved a CR or PR (N=28) that was sustained for at least 20 weeks.

Comparative Bioavailability Studies

IMBRUVICA[®] tablets were evaluated in bioavailability studies. Ibrutinib exposure (C_{max} and AUC_{last}) is comparable following a single 1 x 140 mg dose of IMBRUVICA[®] as either tablets or capsules. In a similar study comparing 560 mg doses of ibrutinib as either 1 x 560 mg tablets or 4 x 140 mg capsules, AUC_{last} was comparable for the two dosage forms and C_{max} was 28% lower for IMBRUVICA[®] 560 mg tablets as compared with the capsules. The difference in C_{max} seen with the 560 mg doses is considered not to be clinically meaningful.

DETAILED PHARMACOLOGY

Pharmacodynamics

The effects of ibrutinib and the dihydrodiol metabolite on hERG channel-mediated ion current were evaluated in voltage-clamped HEK293 cells that stably express hERG potassium channels. The IC_{50} for inhibitory effect of ibrutinib on hERG channel current was 970 nM (427 ng/mL). The IC_{50} for inhibitory effect of the dihydrodiol metabolite on hERG channel current was 9600 nM (4555 ng/mL).

The acute effects of ibrutinib treatment on cardiovascular function were also assessed in dogs up to doses of 150 mg/kg. Lowered heart rate and increased blood pressure were observed at doses ≥ 24 mg/kg (≥ 7.2 times human exposure at the dose of 420 mg daily based on C_{max}). There was no treatment-related prolongation of QT_c intervals observed at any dose level. Shortening of the QT_c interval was observed at a dose of 150 mg/kg (≥ 5.6 times human exposure at the dose of 420 mg daily based on C_{max}).

There were no ibrutinib-related acute effects on CNS or respiratory function in rats at doses up to 150 mg/kg (approximately 22 times human exposure at the dose of 420 mg daily based on C_{max}).

TOXICOLOGY

Carcinogenicity and Mutagenicity

Ibrutinib was not carcinogenic in a 6-month study in the transgenic (Tg.rasH2) mouse at oral doses up to 2000 mg/kg/day resulting in exposures approximately 23 (males) to 37 (females) times higher than the exposure in humans at a dose of 560 mg daily.

Ibrutinib was not genotoxic *in vitro* in bacterial reverse mutation (Ames) and chromosomal aberrations assays. Ibrutinib was also non-clastogenic *in vivo* in the mouse bone marrow erythrocyte micronucleus assay.

Chronic Toxicity

In rats and dogs, lymphoid organs and the gastrointestinal tract were identified as target organs/tissues of toxicity. Additional histopathological changes were noted in the pancreas and bone in rats, but were not observed in dogs.

The following adverse effects were seen in studies up to 13-weeks duration in rats and dogs. Ibrutinib was found to induce gastrointestinal effects (soft feces/diarrhea and/or inflammation) in rats at human equivalent doses (HEDs) ≥ 16 mg/kg/day and in dogs at HEDs ≥ 32 mg/kg/day (≥ 4 times human clinical exposure at the dose of 420 mg daily based on AUC). Effects on lymphoid tissue (lymphoid depletion) were also induced at HEDs ≥ 28 mg/kg/day in rats and ≥ 32 mg/kg/day in dogs (≥ 4 times human clinical exposure at the dose of 420 mg daily based on AUC). In rats, moderate pancreatic acinar cell atrophy was observed after 13 weeks of administration at HEDs ≥ 16 mg/kg/day (≥ 8 times human clinical exposure at the dose of 420 mg daily based on AUC). Mildly decreased trabecular and cortical bone was seen in female rats administered HEDs ≥ 16 mg/kg/day for 13 weeks (≥ 8 times human clinical exposure at the dose of 420 mg daily based on AUC). All notable findings in rats and dogs fully or partially reversed following recovery periods of 6 to 13 weeks.

In a 6-month repeat dose toxicity study in rats, effects on the pancreas (minimal to mild acinar atrophy or hemorrhage) were observed at HEDs ≥ 4 mg/kg/day (≥ 2.4 times human clinical exposure at the dose of 420 mg daily based on AUC). These effects were considered non-adverse due to lack of corresponding evidence of functional perturbation. In a 9-month repeat dose toxicity study in dogs, effects on lymphoid tissue (minimal lymphoid depletion in Peyer's patches and/or minimal to mild lymphoid depletion with sinus congestion in the peripheral lymph nodes) were observed at HEDs ≥ 16 mg/kg/day (≥ 0.3 times human clinical exposure at the dose of 420 mg daily based on AUC). These findings in rats and dogs fully or partially reversed following a 1-month recovery period.

Reproductive and Developmental Toxicity

In the general toxicology studies conducted in rats and dogs, orally administered ibrutinib did not result in adverse effects on reproductive organs.

In a study of fertility and early embryonic development in rats, ibrutinib administered orally before cohabitation and through mating and implantation had no effects on fertility or reproductive capacities in males or females up to the maximum dose tested, 100 mg/kg/day (approximately 8 times in males and 30 times in females of the clinical dose of 420 mg daily based on AUC).

Ibrutinib was studied for effects on embryo-fetal development in pregnant rats given oral doses of 10, 40 and 80 mg/kg/day during organogenesis. At a dose of 80 mg/kg/day (approximately 18 times the AUC of ibrutinib and 9.1 times the AUC of the dihydrodiol metabolite compared to patients at the dose of 420 mg daily), ibrutinib was associated with increased post-implantation loss and increased visceral malformations (heart and major vessels). At a dose of ≥ 40 mg/kg/day (\geq approximately 7.3 times the AUC of ibrutinib and 3.9 times the AUC of the dihydrodiol metabolite compared to patients at a dose of 420 mg daily), ibrutinib was associated with decreased fetal weights. The no-observed-adverse-effect level (NOAEL) for rat embryo-fetal development was 10 mg/kg/day (1.9 times the AUC of ibrutinib and 1.0 times the AUC of the dihydrodiol metabolite in patients receiving 420 mg daily).

Ibrutinib was administered orally to pregnant rabbits during the period of organogenesis at oral doses of 5, 15, and 45 mg/kg/day. At a dose of ≥ 15 mg/kg/day (≥ 2.8 times the AUC of ibrutinib and ≥ 1.4 times the AUC of the dihydrodiol metabolite in patients receiving 420 mg daily), ibrutinib was associated with skeletal malformations (fused sternebrae). At a dose of

45 mg/kg/day (6.9 times the AUC of ibrutinib and 4.6 times the AUC of the dihydrodiol metabolite in patients receiving 420 mg daily), ibrutinib was associated with increased post-implantation loss. Maternal toxicity (i.e., reduced food consumption and body weights) was evident at 45 mg/kg/day. The NOAEL for rabbit embryo-fetal development was 5 mg/kg/day (1.1 times the AUC of ibrutinib and 0.4 times the AUC of the dihydrodiol metabolite in patients receiving 420 mg daily).

REFERENCES

1. Honigberg LA, Smith AM, Sirisawad M, Verner E, Loury D, Chang B, et al. The Bruton tyrosine kinase inhibitor PCI-32765 blocks B-cell activation and is efficacious in models of autoimmune disease and B-cell malignancy. *Proc Natl Acad Sci U S A*. 2010;107(29):13075-80.
2. Ponader S, Chen SS, Buggy JJ, Balakrishnan K, Gandhi V, Wierda WG, et al. The Bruton tyrosine kinase inhibitor PCI-32765 thwarts chronic lymphocytic leukemia cell survival and tissue homing in vitro and in vivo. *Blood*. 2012;119(5):1182-9.
3. de Rooij MF, Kuil A, Geest CR, Eldering E, Chang BY, Buggy JJ, et al. The clinically active BTK inhibitor PCI-32765 targets B-cell receptor- and chemokine-controlled adhesion and migration in chronic lymphocytic leukemia. *Blood*. 2012;119(11):2590-4.
4. Advani RH, Buggy JJ, Sharman JP, Smith SM, Boyd TE, Grant B, et al. Bruton tyrosine kinase inhibitor ibrutinib (PCI-32765) has significant activity in patients with relapsed/refractory B-cell malignancies. *J Clin Oncol*. 2013;31(1):88-94.
5. Burger JA, Buggy JJ. Bruton tyrosine kinase inhibitor ibrutinib (PCI-32765). *Leuk Lymphoma*. 2013;54(11):2385-91.
6. Byrd JC, Furman RR, Coutre SE, Flinn IW, Burger JA, Blum KA, et al. Targeting BTK with ibrutinib in relapsed chronic lymphocytic leukemia. *N Engl J Med*. 2013;369(1):32-42.
7. Wang ML, Rule S, Martin P, Goy A, Auer R, Kahl BS, et al. Targeting BTK with ibrutinib in relapsed or refractory mantle-cell lymphoma. *N Engl J Med*. 2013;369(6):507-16.
8. Woyach JA, Smucker K, Smith LL, Lozanski A, Zhong Y, Ruppert AS, et al. Prolonged lymphocytosis during ibrutinib therapy is associated with distinct molecular characteristics and does not indicate a suboptimal response to therapy. *Blood*. 2014;123(12):1810.
9. Byrd JC, Brown JR, O'Brien S, Barrientos JC, Kay NE, Reddy NM, et al. Ibrutinib versus ofatumumab in previously treated chronic lymphoid leukemia. *N Engl J Med*. 2014;371(3):213-23.
10. Burger JA, Tedeschi A, Barr PM, Robak T, Owen C, Ghia P, et al. Ibrutinib versus chlorambucil in treatment-naïve chronic lymphocytic leukemia. *N Engl J Med*. 2015;373(25):2425-37.
11. Islam P, Daniel C, Strelec L, et al. Ibrutinib-induced pneumonitis in patients with chronic lymphocytic leukemia. *Blood*. 2016;127:1064-1067.
12. Chanan-Khan A, Cramer P, Demirkan F, Fraser G, Santucci Silva R, Grosicki S, et al. Ibrutinib combined with bendamustine and rituximab compared with placebo, bendamustine, and rituximab for previously treated chronic lymphocytic leukaemia or small lymphocytic lymphoma (HELIOS): a randomised, double-blind, phase 3 study. *Lancet Oncol*. 2015;S1470-2045(15)00465-9.

READ THIS FOR SAFE AND EFFECTIVE USE OF YOUR MEDICINE

PATIENT MEDICATION INFORMATION

IMBRUVICA®
ibrutinib tablets
ibrutinib capsules

Read this carefully before you start taking **IMBRUVICA®** and each time you get a refill. This leaflet is a summary and will not tell you everything about this drug. Talk to your healthcare professional about your medical condition and treatment and ask if there is any new information about **IMBRUVICA®**.

Serious Warnings and Precautions

IMBRUVICA® should only be prescribed by a qualified doctor who is experienced in the use of anti-cancer drugs.

- Major bleeding events, some fatal, have been reported (see below)
- **IMBRUVICA®** should not be used in patients with moderate or severe liver problems (see below)
- **IMBRUVICA®** should not be used with certain medications that can increase the blood level of **IMBRUVICA®** (see below)

What is **IMBRUVICA® used for?**

IMBRUVICA® is used in adults to treat:

- **Chronic Lymphocytic Leukemia (CLL):**
 - **IMBRUVICA®** is used to treat patients with active CLL who have not had prior therapy, including those with a deletion of the “TP53” gene (17p deletion). In patients with active CLL who have not had prior therapy, **IMBRUVICA®** can also be used in combination with obinutuzumab.
 - **IMBRUVICA®** is also used to treat patients with CLL who have received at least one prior therapy, including those with a deletion of the “TP53” gene (17p deletion). In patients with CLL who have received at least one prior therapy, **IMBRUVICA®** can also be used in combination with bendamustine and rituximab.
- **Mantle Cell Lymphoma (MCL):** **IMBRUVICA®** is used to treat patients with previously treated MCL when the disease has come back or has not responded to treatment.
- **Marginal Zone Lymphoma (MZL):** **IMBRUVICA®** is used to treat patients with MZL. It is used when they need medicine and not radiation or surgery. It is for patients who have received at least one prior therapy including an antibody that acts against their cancer. This antibody is called anti-CD20.
- **Waldenström’s Macroglobulinemia (WM):** **IMBRUVICA®** is used to treat patients with WM, and can also be used in combination with rituximab.
- **Chronic graft versus host disease (cGVHD):** **IMBRUVICA®** is used to treat patients with cGVHD after failure of first line corticosteroid therapy and who need additional therapy.
- It is not known if **IMBRUVICA®** is safe and effective in children under the age of 18 years.

How does IMBRUVICA® work?

IMBRUVICA® blocks a specific protein in the body that helps cancer cells live and grow. This protein is called “Bruton's Tyrosine Kinase.” By blocking this protein, IMBRUVICA® may help kill and reduce the number of cancer cells and slow the spread of the cancer.

What are the ingredients in IMBRUVICA®?

Medicinal ingredient: ibrutinib

Non-medicinal ingredients:

Tablets: colloidal silicon dioxide, croscarmellose sodium, lactose monohydrate, magnesium stearate, microcrystalline cellulose, povidone, and sodium lauryl sulfate. The tablet film coatings contain black iron oxide (140 mg, 280 mg, 420 mg tablets), polyethylene glycol, polyvinyl alcohol, red iron oxide (280 mg, 560 mg tablets), talc, titanium dioxide, and yellow iron oxide (140 mg, 420 mg, 560 mg tablets).

Capsules: croscarmellose sodium, magnesium stearate, microcrystalline cellulose, and sodium lauryl sulfate. The white capsule shell contains gelatin and titanium dioxide. Capsules are printed with ink containing iron oxide black and shellac.

IMBRUVICA® comes in the following dosage forms:

Tablets: 140 mg, 280 mg, 420 mg, 560 mg

Capsules: 140 mg

Do not use IMBRUVICA® if you:

- are allergic to ibrutinib or any of the other ingredients in this medicine or components of the container. If you are not sure about this, talk to your healthcare professional before taking IMBRUVICA®.

To help avoid side effects and ensure proper use, talk to your healthcare professional before you take IMBRUVICA®. Talk about any health conditions or problems you may have, including if you:

- have ever had unusual bleeding or bruising or are on any medicines that increase your risk of bleeding such as aspirin, anti-inflammatories (e.g., ibuprofen, naproxen, and others), warfarin, heparin, other medications to prevent or treat blood clots (e.g., dabigatran, rivaroxaban, apixaban), or any supplements that increase your risk of bleeding such as fish oil, flaxseed, or vitamin E. You should not take warfarin (COUMADIN®) with IMBRUVICA®.
- have or have had heart rhythm problems or severe heart failure, or if you have any of the following: fast and irregular heartbeat, lightheadedness, dizziness, shortness of breath, chest discomfort, swollen legs, or if you faint.
- have or are at increased risk of heart disease.
- have high blood pressure.
- have any infection.
- have had a hepatitis B infection (a viral infection of the liver).
- have liver or kidney problems. You should not take this drug if you have certain liver problems.
- are planning to have any medical, surgical or dental procedure. Your doctor may ask you to stop taking IMBRUVICA® for a short time.

Other warnings you should know about:

Tests and check-ups before and during treatment:

Laboratory tests may show that your blood count contains more white blood cells (called “lymphocytes”) in the first few weeks of treatment. This is expected and may last for a few weeks or months. This does not necessarily mean that your blood cancer is getting worse. Your doctor will check your blood counts before and during the treatment. In rare cases your doctor may need to give you another medicine. Talk to your doctor about what your test results mean.

Your doctor will check your blood pressure during treatment and may need to give you another medicine to control your blood pressure.

Children and adolescents:

IMBRUVICA[®] is not recommended for use in patients under 18 years of age.

IMBRUVICA[®] with food:

Do not take IMBRUVICA[®] with grapefruit or Seville oranges; this includes eating them, drinking the juice, or taking supplements that might contain them. These products may increase the amount of IMBRUVICA[®] in your blood.

Pregnancy, breast-feeding and fertility:

- IMBRUVICA[®] can harm your unborn baby.
- Do not get pregnant while you are taking IMBRUVICA[®]. Women of childbearing age must use two forms of effective birth control methods together during treatment with IMBRUVICA[®] and for at least 3 months after the last dose of IMBRUVICA[®].
- If you are pregnant, think you may be pregnant or are planning to have a baby, ask your healthcare professional for advice before taking IMBRUVICA[®].
- Tell your healthcare professional immediately if you become pregnant.
- Do not breast-feed while you are taking IMBRUVICA[®].
- Do not father a child while taking IMBRUVICA[®] and for 3 months after stopping treatment. Use condoms and do not donate sperm during treatment and for 3 months after your treatment has finished. If you plan to father a child, talk to your healthcare professional before taking IMBRUVICA[®].
- Men who are sexually active with a pregnant woman must use a condom during and for 3 months after treatment with IMBRUVICA[®].

Driving and using machines:

You may feel tired or dizzy after taking IMBRUVICA[®], which may affect your ability to drive and use tools or machines. Ask your healthcare professional about your ability to drive and use tools or machines while taking IMBRUVICA[®].

Tell your doctor or pharmacist about all the medicines you take, including any drugs, vitamins, minerals, natural supplements or alternative medicines.

The following may interact with IMBRUVICA[®]:

- medicines called antibiotics used to treat bacterial infections (clarithromycin, ciprofloxacin, erythromycin, rifampin).
- medicines for fungal infections (ketoconazole, itraconazole, fluconazole, voriconazole, posaconazole).

- medicines for HIV infection (indinavir, nelfinavir, ritonavir, saquinavir, atazanavir, darunavir/ritonavir, cobicistat, fosamprenavir).
- medicine to prevent nausea and vomiting (aprepitant).
- medicines called kinase inhibitors for treatment of other cancers (crizotinib, imatinib).
- medicines called calcium channel blockers for high blood pressure, chest pain, irregular heartbeat and other heart problems (diltiazem, verapamil).
- medicines called statins to treat high cholesterol (rosuvastatin).
- heart medicines/anti-arrhythmics (amiodarone, dronedarone).
- medicines that may increase your risk of bleeding, including:
 - aspirin and anti-inflammatories such as ibuprofen or naproxen.
 - blood thinners such as warfarin, heparin or other medicines for blood clots such as dabigatran, rivaroxaban, apixaban.
 - supplements such as fish oil, vitamin E and flaxseed.
- medicines used to prevent seizures or to treat epilepsy or medicines used to treat a painful condition of the face called trigeminal neuralgia (carbamazepine and phenytoin).
- an herbal medicine used for depression (St. John's Wort).

If you are taking digoxin, a medicine used for heart problems, or methotrexate, a medicine used to treat other cancers or to reduce the activity of the immune system (e.g., for rheumatoid arthritis or psoriasis), it should be taken at least 6 hours before or after IMBRUVICA®.

How to take IMBRUVICA®:

- Take IMBRUVICA® as prescribed by your doctor.
- Swallow IMBRUVICA® whole, with a glass of water. Do not open, break or chew capsules or tablets. Do not take IMBRUVICA® with grapefruit juice.
- Take IMBRUVICA® at about the same time each day.
- Drink plenty of fluids to stay hydrated while taking IMBRUVICA®. This will help your kidneys continue to function properly.

Usual adult dose:

- **Chronic Lymphocytic Leukemia (CLL):** 420 mg once a day
- **Waldenström's Macroglobulinemia (WM):** 420 mg once a day
- **Chronic graft versus host disease (cGVHD):** 420 mg once a day
- **Mantle Cell Lymphoma (MCL):** 560 mg once a day
- **Marginal Zone Lymphoma (MZL):** 560 mg once a day

Your doctor may decide that you should take a lower dose if you get side effects.

For the treatment of CLL and WM, your doctor may prescribe IMBRUVICA® alone or in combination with other treatments.

IMBRUVICA® is given as a continuous daily therapy, which means you need to take it every day until your disease no longer responds to treatment or you experience unacceptable side effects. Do not change your dose or stop taking IMBRUVICA® unless your doctor tells you to.

Overdose:

If you think you have taken too much IMBRUVICA[®] contact your healthcare professional, hospital emergency department or regional Poison Control Centre immediately, even if there are no symptoms.

Missed dose:

If you miss a dose of IMBRUVICA[®] take it as soon as you remember on the same day. Take your next dose of IMBRUVICA[®] at your regular time on the next day. Do not take extra doses of IMBRUVICA[®] to make up for a missed dose. Call your healthcare professional if you are not sure of what to do.

What are possible side effects from using IMBRUVICA[®]?

These are not all the possible side effects you may feel when taking IMBRUVICA[®]. If you experience any side effects not listed here, contact your healthcare professional. Please also see Warnings and Precautions.

- **Lymphocytosis:** An increase in the number of white blood cells, specifically lymphocytes may be reported in your blood test results (see **Other warnings you should know about**). This increase in white blood cells is expected in the first few weeks of treatment and may last for 3 or more months. Uncommonly, this increase may be severe, causing cells to clump together (leukostasis). Your doctor will monitor your blood counts. Talk to your doctor about what your blood test results mean.
- **Diarrhea:** You may experience an increase in frequency of loose or watery stools. If you have diarrhea that lasts for more than a week, your doctor may need to give you treatment to manage your diarrhea such as a fluid and salt replacement or another medicine. Contact your doctor if your diarrhea persists.
- **Viral, bacterial, or fungal infections:** Infections can be serious and may lead to death. Contact your doctor if you have fever, chills, weakness, confusion, body aches, cold or flu symptoms, feel tired or feel short of breath, or have any other signs or symptoms of a possible infection.
- Fatigue, lack of energy, anxiety, difficulty falling or staying asleep
- Common cold
- Muscle aches, muscle spasm, joint aches
- Headache, dizziness, weakness
- Rash, skin infection
- Inflammation of the fatty tissue underneath the skin
- Nausea, sore mouth, constipation, vomiting, loss of appetite, stomach pain, indigestion
- Nail changes such as brittle fingernails and toenails
- Types of skin cancers that are not melanoma, most frequently squamous cell or basal cell skin cancers, have happened in people taking IMBRUVICA[®]. Other cancers that are not skin cancer have happened in people taking IMBRUVICA[®]. Talk to your doctor about monitoring for new skin cancer symptoms.

Serious side effects and what to do about them			
Symptom / effect	Talk to your healthcare professional		Stop taking drug and get immediate medical help
	Only if severe	In all cases	
VERY COMMON			
Anemia (low red blood cells): fatigue, loss of energy, weakness, shortness of breath		✓	
Neutropenia (low neutrophils, a type of white blood cell): fever, chills or sweating or any signs of infection		✓	
Thrombocytopenia (low platelets): bruising, bleeding, fatigue and weakness		✓	
Edema (abnormal accumulation of fluid): swollen hands, ankles or feet		✓	
Being short of breath		✓	
Fever		✓	
Pneumonia (infection of the lungs): cough with or without mucus, fever, chills, shortness of breath		✓	
Sinusitis (sinus infection): thick, yellow, smelly discharge from the nose, pressure or pain in the face and eyes, congestion, headache		✓	
Bruising: small red or purple spots caused by bleeding under the skin	✓		
High blood pressure		✓	
COMMON			
Urinary tract infection: pain or burning when urinating, bloody or cloudy urine, foul smelling urine		✓	
Hypokalemia (low potassium levels in the blood): muscle weakness, cramps, twitches, abnormal heart rhythms		✓	
Nose bleeds		✓	
Severe diarrhea: increased number of bowel movements, watery or bloody stool, stomach pain and/or cramps		✓	

Serious side effects and what to do about them			
Symptom / effect	Talk to your healthcare professional		Stop taking drug and get immediate medical help
	Only if severe	In all cases	
Arrhythmia (irregular heart rhythm): palpitations, light-headedness, dizziness, shortness of breath, chest discomfort, fainting		✓	
Blurred vision	✓		
Infection of the blood: feeling dizzy or faint, confusion or disorientation, diarrhea, nausea, vomiting, slurred speech, severe muscle pain			✓
Serious bleeding problems sometimes resulting in death: blood in your stool or urine, bleeding that lasts for a long time or that you cannot control, coughing up blood or blood clots, increased bruising, feel dizzy or weak, confusion, change in your speech, or a headache that lasts a long time			✓
Interstitial lung disease (inflammation within the lungs): difficulty breathing or persistent cough		✓	
Tumour Lysis Syndrome (sudden, rapid death of cancer cells due to the treatment): nausea, vomiting, decreased urination, irregular heartbeat, confusion, delirium, seizures			✓
Hyperuricemia (elevated levels of uric acid in the blood): red, warm, and swollen joints, flank pain, blood in urine, or cream-colored skin nodules		✓	
Peripheral Neuropathy: weakness, numbness, tingling, pain, or hot or cold sensation in hands, feet or other parts of the body	✓		

Serious side effects and what to do about them			
Symptom / effect	Talk to your healthcare professional		Stop taking drug and get immediate medical help
	Only if severe	In all cases	
Kidney failure: decreased or lack of urination, nausea, swelling of the ankles, legs or feet, fatigue, confusion, seizures or coma			✓
UNCOMMON			
Leukostasis (severe increase in white blood cells): fever, fainting, bleeding, bruising, weight loss, general pain, lack of energy, severe headache, trouble walking		✓	
Severe allergic reactions: swelling of face, eyes, lips, mouth, or tongue, trouble swallowing or breathing, itchy skin rash, redness of the skin			✓
Stevens-Johnson syndrome: severe rash with blisters and peeling skin, particularly around the mouth, nose, eyes and genitals			✓
Severe liver problems: nausea, loss of appetite, fatigue, jaundice (yellowing of your skin and eyes), pain in your upper right abdomen, dark urine, disorientation, confusion		✓	
Inflammation of the eye (pink eye)	✓		
Mini-stroke (temporary low blood flow to the brain) or stroke (bleeding or blood clot in the brain): sudden numbness, weakness or tingling of the face, arm, or leg, particularly on one side of the body, difficulty speaking or understanding speech, blurred vision, dizziness, difficulty walking and loss of balance, sudden headache, difficulty swallowing			✓

If you have a troublesome symptom or side effect that is not listed here or becomes bad enough to interfere with your daily activities, talk to your healthcare professional.

Reporting Side Effects

You can report any suspected side effects associated with the use of health products to Health Canada by:

- Visiting the Web page on Adverse Reaction Reporting (<https://www.canada.ca/en/health-canada/services/drugs-health-products/medeffect-canada/adverse-reaction-reporting.html>) for information on how to report online, by mail or by fax; or
- Calling toll-free at 1-866-234-2345.

NOTE: Contact your health professional if you need information about how to manage your side effects. The Canada Vigilance Program does not provide medical advice.

Storage:

Store IMBRUVICA[®] at room temperature between 15°C and 30°C.

Keep out of the reach and sight of children.

If you want more information about IMBRUVICA[®]:

- Talk to your healthcare professional.
- For questions or concerns, contact the manufacturer, Janssen Inc. (www.janssen.com/canada).
- Find the full product monograph that is prepared for healthcare professionals and includes this Patient Medication Information by visiting the Health Canada website (<https://www.canada.ca/en/health-canada/services/drugs-health-products/drug-products/drug-product-database.html>), the manufacturer's website www.janssen.com/canada, or by contacting the manufacturer at: 1-800-567-3331 or 1-800-387-8781.

This leaflet was prepared by Janssen Inc., Toronto, Ontario, M3C 1L9.

Co-developed with Pharmacyclics.

© 2020 JANSSEN Inc.

© 2020 Pharmacyclics

Last revised: September 24, 2020

All trademarks used under license.

All other third party trademarks are trademarks of their respective owners.

HIGHLIGHTS OF PRESCRIBING INFORMATION

These highlights do not include all the information needed to use IMBRUVICA safely and effectively. See full prescribing information for IMBRUVICA.

IMBRUVICA® (ibrutinib) capsules, for oral use

IMBRUVICA® (ibrutinib) tablets, for oral use

Initial U.S. Approval: 2013

RECENT MAJOR CHANGES

Dosage and Administration (2.1) 04/2020
Warnings and Precautions (5.1, 5.2, 5.3, 5.4, 5.5, 5.6) 04/2020

INDICATIONS AND USAGE

IMBRUVICA is a kinase inhibitor indicated for the treatment of adult patients with:

- Mantle cell lymphoma (MCL) who have received at least one prior therapy (1.1).
Accelerated approval was granted for this indication based on overall response rate. Continued approval for this indication may be contingent upon verification and description of clinical benefit in a confirmatory trial.
- Chronic lymphocytic leukemia (CLL)/Small lymphocytic lymphoma (SLL) (1.2).
- Chronic lymphocytic leukemia (CLL)/Small lymphocytic lymphoma (SLL) with 17p deletion (1.3).
- Waldenström's macroglobulinemia (WM) (1.4).
- Marginal zone lymphoma (MZL) who require systemic therapy and have received at least one prior anti-CD20-based therapy (1.5).
Accelerated approval was granted for this indication based on overall response rate. Continued approval for this indication may be contingent upon verification and description of clinical benefit in a confirmatory trial.
- Chronic graft versus host disease (cGVHD) after failure of one or more lines of systemic therapy (1.6).

DOSAGE AND ADMINISTRATION

- MCL and MZL: 560 mg taken orally once daily (2.1).
- CLL/SLL, WM, and cGVHD: 420 mg taken orally once daily (2.1).

Dose should be taken orally with a glass of water. Do not open, break, or chew the capsules. Do not cut, crush, or chew the tablets (2.1).

DOSAGE FORMS AND STRENGTHS

Capsules: 70 mg and 140 mg (3)
Tablets: 140 mg, 280 mg, 420 mg, and 560 mg (3)

CONTRAINDICATIONS

None (4)

WARNINGS AND PRECAUTIONS

- Hemorrhage: Monitor for bleeding and manage (5.1).
- Infections: Monitor patients for fever and infections, evaluate promptly, and treat (5.2).
- Cytopenias: Check complete blood counts monthly (5.3).
- Cardiac arrhythmias: Monitor for symptoms of arrhythmias and manage (5.4).
- Hypertension: Monitor blood pressure and treat (5.5).
- Second Primary Malignancies: Other malignancies have occurred in patients, including skin cancers, and other carcinomas (5.6).
- Tumor Lysis Syndrome (TLS): Assess baseline risk and take precautions. Monitor and treat for TLS (5.7).
- Embryo-Fetal Toxicity: Can cause fetal harm. Advise females of reproductive potential of the potential risk to a fetus and to use effective contraception (5.8, 8.1, 8.3).

ADVERSE REACTIONS

The most common adverse reactions ($\geq 30\%$) in patients with B-cell malignancies (MCL, CLL/SLL, WM and MZL) are thrombocytopenia, diarrhea, fatigue, musculoskeletal pain, neutropenia, rash, anemia, and bruising (6).

The most common adverse reactions ($\geq 20\%$) in patients with cGVHD are fatigue, bruising, diarrhea, thrombocytopenia, muscle spasms, stomatitis, nausea, hemorrhage, anemia, and pneumonia (6).

To report SUSPECTED ADVERSE REACTIONS, contact Pharmacovigilance at 1-877-877-3536 or FDA at 1-800-FDA-1088 or www.fda.gov/medwatch.

DRUG INTERACTIONS

- CYP3A Inhibitors: Modify IMBRUVICA dose as described (2.3, 7.1).
- CYP3A Inducers: Avoid coadministration with strong CYP3A inducers (7.2).

USE IN SPECIFIC POPULATIONS

- Lactation: Advise not to breastfeed. (8.2)
- Hepatic Impairment (based on Child-Pugh criteria): Avoid use of IMBRUVICA in patients with severe baseline hepatic impairment. In patients with mild or moderate impairment, reduce IMBRUVICA dose (2.4, 8.6).

See 17 for PATIENT COUNSELING INFORMATION and FDA approved patient labeling.

Revised: 08/2020

FULL PRESCRIBING INFORMATION: CONTENTS*

1 INDICATIONS AND USAGE

- Mantle Cell Lymphoma
- Chronic Lymphocytic Leukemia/Small Lymphocytic Lymphoma
- Chronic Lymphocytic Leukemia/Small Lymphocytic Lymphoma with 17p deletion
- Waldenström's Macroglobulinemia
- Marginal Zone Lymphoma
- Chronic Graft versus Host Disease

2 DOSAGE AND ADMINISTRATION

- Recommended Dosage
- Dosage Modifications for Adverse Reactions
- Dosage Modifications for Use with CYP3A Inhibitors
- Dosage Modifications for Use in Hepatic Impairment

3 DOSAGE FORMS AND STRENGTHS

4 CONTRAINDICATIONS

5 WARNINGS AND PRECAUTIONS

- Hemorrhage
- Infections
- Cytopenias
- Cardiac Arrhythmias
- Hypertension
- Second Primary Malignancies
- Tumor Lysis Syndrome
- Embryo-Fetal Toxicity

6 ADVERSE REACTIONS

- Clinical Trials Experience
- Postmarketing Experience

7 DRUG INTERACTIONS

- Effect of CYP3A Inhibitors on Ibrutinib
- Effect of CYP3A Inducers on Ibrutinib

8 USE IN SPECIFIC POPULATIONS

- Pregnancy
- Lactation
- Females and Males of Reproductive Potential
- Pediatric Use
- Geriatric Use
- Hepatic Impairment
- Plasmapheresis

10 OVERDOSAGE

11 DESCRIPTION

12 CLINICAL PHARMACOLOGY

- Mechanism of Action
- Pharmacodynamics
- Pharmacokinetics

13 NONCLINICAL TOXICOLOGY

- Carcinogenesis, Mutagenesis, Impairment of Fertility

14 CLINICAL STUDIES

- Mantle Cell Lymphoma
- Chronic Lymphocytic Leukemia/Small Lymphocytic Lymphoma
- Waldenström's Macroglobulinemia
- Marginal Zone Lymphoma
- Chronic Graft versus Host Disease

16 HOW SUPPLIED/STORAGE AND HANDLING

17 PATIENT COUNSELING INFORMATION

* Sections or subsections omitted from the full prescribing information are not listed.

FULL PRESCRIBING INFORMATION

1 INDICATIONS AND USAGE

1.1 Mantle Cell Lymphoma

IMBRUVICA is indicated for the treatment of adult patients with mantle cell lymphoma (MCL) who have received at least one prior therapy.

Accelerated approval was granted for this indication based on overall response rate. Continued approval for this indication may be contingent upon verification and description of clinical benefit in a confirmatory trial [*see Clinical Studies (14.1)*].

1.2 Chronic Lymphocytic Leukemia/Small Lymphocytic Lymphoma

IMBRUVICA is indicated for the treatment of adult patients with chronic lymphocytic leukemia (CLL)/small lymphocytic lymphoma (SLL).

1.3 Chronic Lymphocytic Leukemia/Small Lymphocytic Lymphoma with 17p deletion

IMBRUVICA is indicated for the treatment of adult patients with chronic lymphocytic leukemia (CLL)/small lymphocytic lymphoma (SLL) with 17p deletion.

1.4 Waldenström's Macroglobulinemia

IMBRUVICA is indicated for the treatment of adult patients with Waldenström's macroglobulinemia (WM).

1.5 Marginal Zone Lymphoma

IMBRUVICA is indicated for the treatment of adult patients with marginal zone lymphoma (MZL) who require systemic therapy and have received at least one prior anti-CD20-based therapy.

Accelerated approval was granted for this indication based on overall response rate [*see Clinical Studies (14.4)*]. Continued approval for this indication may be contingent upon verification and description of clinical benefit in a confirmatory trial.

1.6 Chronic Graft versus Host Disease

IMBRUVICA is indicated for the treatment of adult patients with chronic graft-versus-host disease (cGVHD) after failure of one or more lines of systemic therapy.

2 DOSAGE AND ADMINISTRATION

2.1 Recommended Dosage

Mantle Cell Lymphoma and Marginal Zone Lymphoma

The recommended dosage of IMBRUVICA for MCL and MZL is 560 mg orally once daily until disease progression or unacceptable toxicity.

Chronic Lymphocytic Leukemia/Small Lymphocytic Lymphoma and Waldenström's Macroglobulinemia

The recommended dosage of IMBRUVICA for CLL/SLL and WM is 420 mg orally once daily until disease progression or unacceptable toxicity.

For CLL/SLL, IMBRUVICA can be administered as a single agent, in combination with rituximab or obinutuzumab, or in combination with bendamustine and rituximab (BR).

For WM, IMBRUVICA can be administered as a single agent or in combination with rituximab.

When administering IMBRUVICA in combination with rituximab or obinutuzumab, consider administering IMBRUVICA prior to rituximab or obinutuzumab when given on the same day.

Chronic Graft versus Host Disease

The recommended dosage of IMBRUVICA for cGVHD is 420 mg orally once daily until cGVHD progression, recurrence of an underlying malignancy, or unacceptable toxicity. When a patient no longer requires therapy for the treatment of cGVHD, IMBRUVICA should be discontinued considering the medical assessment of the individual patient.

Administration

Administer IMBRUVICA at approximately the same time each day with a glass of water.

Swallow tablets or capsule whole. Do not open, break, or chew the capsules. Do not cut, crush, or chew the tablets.

If a dose of IMBRUVICA is not taken at the scheduled time, it can be taken as soon as possible on the same day with a return to the normal schedule the following day. Do not take extra doses of IMBRUVICA to make up for the missed dose.

2.2 Dosage Modifications for Adverse Reactions

Interrupt IMBRUVICA therapy for any Grade 3 or greater non-hematological toxicities, Grade 3 or greater neutropenia with infection or fever, or Grade 4 hematological toxicities. Once the adverse reaction has improved to Grade 1 or baseline (recovery), IMBRUVICA may be reinitiated at the starting dose. If the adverse reaction reoccurs, reduce dose by 140 mg per day. Consider a second reduction of dose by 140 mg as needed. If these adverse reactions persist or recur following two dose reductions, discontinue IMBRUVICA.

Recommended dose modifications are described below:

Toxicity Occurrence	Dose Modification for MCL and MZL After Recovery Starting Dose = 560 mg	Dose Modification for CLL/SLL, WM, and cGVHD After Recovery Starting Dose = 420 mg
First	Restart at 560 mg daily	Restart at 420 mg daily
Second	Restart at 420 mg daily	Restart at 280 mg daily
Third	Restart at 280 mg daily	Restart at 140 mg daily
Fourth	Discontinue IMBRUVICA	Discontinue IMBRUVICA

2.3 Dosage Modifications for Use with CYP3A Inhibitors

Recommended dosage modifications are described below [see *Drug Interactions (7.1)*]:

Patient Population	Coadministered Drug	Recommended IMBRUVICA Dosage
B-Cell Malignancies	<ul style="list-style-type: none"> Moderate CYP3A inhibitor 	280 mg once daily Modify dose as recommended [see <i>Dosage and Administration (2.2)</i>].
	<ul style="list-style-type: none"> Voriconazole 200 mg twice daily Posaconazole suspension 100 mg once daily, 100 mg twice daily, or 200 mg twice daily 	140 mg once daily Modify dose as recommended [see <i>Dosage and Administration (2.2)</i>].
	<ul style="list-style-type: none"> Posaconazole suspension 200 mg three times daily or 400 mg twice daily Posaconazole intravenously 300 mg once daily Posaconazole delayed-release tablets 300 mg once daily 	70 mg once daily Interrupt dose as recommended [see <i>Dosage and Administration (2.2)</i>].
	<ul style="list-style-type: none"> Other strong CYP3A inhibitors 	Avoid concomitant use. If these inhibitors will be used short-term (such as anti-infectives for seven days or less), interrupt IMBRUVICA.
Chronic Graft versus Host Disease	<ul style="list-style-type: none"> Moderate CYP3A inhibitor 	420 mg once daily Modify dose as recommended [see <i>Dosage and Administration (2.2)</i>].
	<ul style="list-style-type: none"> Voriconazole 200 mg twice daily Posaconazole suspension 100 mg once daily, 100 mg twice daily, or 200 mg twice daily 	280 mg once daily Modify dose as recommended [see <i>Dosage and Administration (2.2)</i>].
	<ul style="list-style-type: none"> Posaconazole suspension 200 mg three times daily or 400 mg twice daily Posaconazole intravenously 300 mg once daily Posaconazole delayed-release tablets 300 mg once daily 	140 mg once daily Interrupt dose as recommended [see <i>Dosage and Administration (2.2)</i>].
	<ul style="list-style-type: none"> Other strong CYP3A inhibitors 	Avoid concomitant use. If these inhibitors will be used short-term (such as anti-infectives for seven days or less), interrupt IMBRUVICA.

After discontinuation of a CYP3A inhibitor, resume previous dose of IMBRUVICA [see *Dosage and Administration (2.1)*, *Drug Interactions (7.1)*].

2.4 Dosage Modifications for Use in Hepatic Impairment

The recommended dosage is 140 mg daily for patients with mild hepatic impairment (Child-Pugh class A).

The recommended dosage is 70 mg daily for patients with moderate hepatic impairment (Child-Pugh class B).

Avoid the use of IMBRUVICA in patients with severe hepatic impairment (Child-Pugh class C) [see *Use in Specific Populations* (8.6), *Clinical Pharmacology* (12.3)].

3 DOSAGE FORMS AND STRENGTHS

Capsules:

Each 70 mg capsule is a yellow, opaque capsule marked with “ibr 70 mg” in black ink.

Each 140 mg capsule is a white, opaque capsule marked with “ibr 140 mg” in black ink.

Tablets:

Each 140 mg tablet is a yellow green to green round tablet debossed with “ibr” on one side and “140” on the other side.

Each 280 mg tablet is a purple oblong tablet debossed with “ibr” on one side and “280” on the other side.

Each 420 mg tablet is a yellow green to green oblong tablet debossed with “ibr” on one side and “420” on the other side.

Each 560 mg tablet is a yellow to orange oblong tablet debossed with “ibr” on one side and “560” on the other side.

4 CONTRAINDICATIONS

None

5 WARNINGS AND PRECAUTIONS

5.1 Hemorrhage

Fatal bleeding events have occurred in patients who received IMBRUVICA. Major hemorrhage (\geq Grade 3, serious, or any central nervous system events; e.g., intracranial hemorrhage [including subdural hematoma], gastrointestinal bleeding, hematuria, and post procedural hemorrhage) occurred in 4% of patients, with fatalities occurring in 0.4% of 2,838 patients who received IMBRUVICA in 27 clinical trials. Bleeding events, including bruising and petechiae, occurred in 39% of patients who received IMBRUVICA.

The mechanism for the bleeding events is not well understood.

Use of either anticoagulant or antiplatelet agents concomitantly with IMBRUVICA increases the risk of major hemorrhage. Across clinical trials, 3.1% of 2,838 patients who received IMBRUVICA without antiplatelet or anticoagulant therapy experienced major hemorrhage. The

addition of antiplatelet therapy with or without anticoagulant therapy increased this percentage to 4.4%, and the addition of anticoagulant therapy with or without antiplatelet therapy increased this percentage to 6.1%. Consider the risks and benefits of anticoagulant or antiplatelet therapy when co-administered with IMBRUVICA. Monitor for signs and symptoms of bleeding.

Consider the benefit-risk of withholding IMBRUVICA for at least 3 to 7 days pre- and post-surgery depending upon the type of surgery and the risk of bleeding [see *Clinical Studies (14)*].

5.2 Infections

Fatal and non-fatal infections (including bacterial, viral, or fungal) have occurred with IMBRUVICA therapy. Grade 3 or greater infections occurred in 21% of 1,476 patients who received IMBRUVICA in clinical trials [see *Adverse Reactions (6.1, 6.2)*]. Cases of progressive multifocal leukoencephalopathy (PML) and *Pneumocystis jirovecii* pneumonia (PJP) have occurred in patients treated with IMBRUVICA. Consider prophylaxis according to standard of care in patients who are at increased risk for opportunistic infections. Monitor and evaluate patients for fever and infections and treat appropriately.

5.3 Cytopenias

In 645 patients with B-cell malignancies who received IMBRUVICA as a single agent, grade 3 or 4 neutropenia occurred in 23% of patients, grade 3 or 4 thrombocytopenia in 8% and grade 3 or 4 anemia in 3%, based on laboratory measurements.

Monitor complete blood counts monthly.

5.4 Cardiac Arrhythmias

Fatal and serious cardiac arrhythmias have occurred with IMBRUVICA. Grade 3 or greater ventricular tachyarrhythmias occurred in 0.2% of patients and Grade 3 or greater atrial fibrillation and atrial flutter occurred in 4% of 1,476 patients who received IMBRUVICA in clinical trials. These events have occurred particularly in patients with cardiac risk factors, hypertension, acute infections, and a previous history of cardiac arrhythmias [see *Adverse Reactions (6.1)*].

Periodically monitor patients clinically for cardiac arrhythmias. Obtain an ECG for patients who develop arrhythmic symptoms (e.g., palpitations, lightheadedness, syncope, chest pain) or new onset dyspnea. Manage cardiac arrhythmias appropriately, and if it persists, consider the risks and benefits of IMBRUVICA treatment and follow dose modification guidelines [see *Dosage and Administration (2.2)*].

5.5 Hypertension

Hypertension occurred in 19% of 1,476 patients who received IMBRUVICA in clinical trials. Grade 3 or greater hypertension occurred in 8% of patients. Based on data from 1,124 of these patients, the median time to onset was 5.9 months (range, 0.03 to 24 months).

Monitor blood pressure in patients treated with IMBRUVICA and initiate or adjust anti-hypertensive medication throughout treatment with IMBRUVICA as appropriate.

5.6 Second Primary Malignancies

Other malignancies (10%), including non-skin carcinomas (4%), occurred among the 1,476 patients who received IMBRUVICA in clinical trials. The most frequent second primary malignancy was non-melanoma skin cancer (6%).

5.7 Tumor Lysis Syndrome

Tumor lysis syndrome has been infrequently reported with IMBRUVICA. Assess the baseline risk (e.g., high tumor burden) and take appropriate precautions. Monitor patients closely and treat as appropriate.

5.8 Embryo-Fetal Toxicity

Based on findings in animals, IMBRUVICA can cause fetal harm when administered to a pregnant woman. Administration of ibrutinib to pregnant rats and rabbits during the period of organogenesis caused embryo-fetal toxicity including malformations at exposures that were 2-20 times higher than those reported in patients with hematologic malignancies. Advise pregnant women of the potential risk to a fetus. Advise females of reproductive potential to use effective contraception during treatment with IMBRUVICA and for 1 month after the last dose. *[see Use in Specific Populations (8.1)].*

6 ADVERSE REACTIONS

The following clinically significant adverse reactions are discussed in more detail in other sections of the labeling:

- Hemorrhage *[see Warnings and Precautions (5.1)]*
- Infections *[see Warnings and Precautions (5.2)]*
- Cytopenias *[see Warnings and Precautions (5.3)]*
- Cardiac Arrhythmias *[see Warnings and Precautions (5.4)]*
- Hypertension *[see Warnings and Precautions (5.5)]*
- Second Primary Malignancies *[see Warnings and Precautions (5.6)]*
- Tumor Lysis Syndrome *[see Warnings and Precautions (5.7)]*

6.1 Clinical Trials Experience

Because clinical trials are conducted under widely variable conditions, adverse event rates observed in clinical trials of a drug cannot be directly compared with rates of clinical trials of another drug and may not reflect the rates observed in practice.

The data in the WARNINGS AND PRECAUTIONS reflect exposure to IMBRUVICA in 6 trials as a single agent at 420 mg orally once daily in 475 patients and at 560 mg orally once daily in 174 patients and in 4 trials administered in combination with other drugs at 420 mg orally once daily in 827 patients. Among these 1,476 patients with B-cell malignancies who received IMBRUVICA, 87% were exposed for 6 months or longer and 68% were exposed for greater than one year. In this pooled safety population of 1,476 patients with B-cell malignancies, the most common adverse reactions ($\geq 30\%$) were thrombocytopenia, diarrhea, fatigue, musculoskeletal pain, neutropenia, rash, anemia, and bruising.

Mantle Cell Lymphoma

The data described below reflect exposure to IMBRUVICA in a clinical trial (Study 1104) that included 111 patients with previously treated MCL treated with 560 mg daily with a median treatment duration of 8.3 months.

The most common adverse reactions ($\geq 20\%$) were thrombocytopenia, diarrhea, neutropenia, anemia, fatigue, musculoskeletal pain, peripheral edema, upper respiratory tract infection, nausea, bruising, dyspnea, constipation, rash, abdominal pain, vomiting and decreased appetite (see [Tables 1](#) and [2](#)).

The most common Grade 3 or 4 non-hematological adverse reactions ($\geq 5\%$) were pneumonia, abdominal pain, atrial fibrillation, diarrhea, fatigue, and skin infections.

Fatal and serious cases of renal failure have occurred with IMBRUVICA therapy. Increases in creatinine 1.5 to 3 times the upper limit of normal (ULN) occurred in 9% of patients.

Adverse reactions from the MCL trial (N=111) using single agent IMBRUVICA 560 mg daily occurring at a rate of $\geq 10\%$ are presented in [Table 1](#).

Table 1: Non-Hematologic Adverse Reactions in $\geq 10\%$ of Patients with MCL (N=111)

Body System	Adverse Reaction	All Grades (%)	Grade 3 or Higher (%)
Gastrointestinal disorders	Diarrhea	51	5
	Nausea	31	0
	Constipation	25	0
	Abdominal pain	24	5
	Vomiting	23	0
	Stomatitis	17	1
	Dyspepsia	11	0
General disorders and administration site conditions	Fatigue	41	5
	Peripheral edema	35	3
	Pyrexia	18	1
	Asthenia	14	3
Musculoskeletal and connective tissue disorders	Musculoskeletal pain	37	1
	Muscle spasms	14	0
	Arthralgia	11	0

Body System	Adverse Reaction	All Grades (%)	Grade 3 or Higher (%)
Infections and infestations	Upper respiratory tract infection	34	0
	Urinary tract infection	14	3
	Pneumonia	14	8 [†]
	Skin infections	14	5
	Sinusitis	13	1
Skin and subcutaneous tissue disorders	Bruising	30	0
	Rash	25	3
	Petechiae	11	0
Respiratory, thoracic and mediastinal disorders	Dyspnea	27	5 [†]
	Cough	19	0
	Epistaxis	11	0
Metabolism and nutrition disorders	Decreased appetite	21	2
	Dehydration	12	4
Nervous system disorders	Dizziness	14	0
	Headache	13	0

[†] Includes one event with a fatal outcome.

Table 2: Treatment-Emergent* Hematologic Laboratory Abnormalities in Patients with MCL (N=111)

	Percent of Patients (N=111)	
	All Grades (%)	Grade 3 or 4 (%)
Platelets decreased	57	17
Neutrophils decreased	47	29
Hemoglobin decreased	41	9

* Based on laboratory measurements and adverse reactions

Treatment-emergent Grade 4 thrombocytopenia (6%) and neutropenia (13%) occurred in patients.

Ten patients (9%) discontinued treatment due to adverse reactions in the trial (N=111). The most frequent adverse reaction leading to treatment discontinuation was subdural hematoma (1.8%). Adverse reactions leading to dose reduction occurred in 14% of patients.

Patients with MCL who develop lymphocytosis greater than 400,000/mcL have developed intracranial hemorrhage, lethargy, gait instability, and headache. However, some of these cases were in the setting of disease progression.

Forty percent of patients had elevated uric acid levels on study including 13% with values above 10 mg/dL. Adverse reaction of hyperuricemia was reported for 15% of patients.

Chronic Lymphocytic Leukemia/Small Lymphocytic Lymphoma

The data described below reflect exposure to IMBRUVICA in one single-arm, open-label clinical trial (Study 1102) and five randomized controlled clinical trials (RESONATE, RESONATE-2, HELIOS, iLLUMINATE, and E1912) in patients with CLL/SLL (n=2,016 total, including n=1,133 patients exposed to IMBRUVICA). In general, patients with creatinine

clearance (CLcr) \leq 30 mL/min, AST or ALT \geq 2.5 x ULN, or total bilirubin \geq 1.5x ULN (unless of non-hepatic origin) were excluded from these trials. In Study E1912, patients with AST or ALT $>$ 3 x ULN or total bilirubin $>$ 2.5 x ULN were excluded. Study 1102 included 51 patients with previously treated CLL/SLL. RESONATE included 386 randomized patients with previously treated CLL or SLL who received single agent IMBRUVICA or ofatumumab. RESONATE-2 included 267 randomized patients with treatment naïve CLL or SLL who were 65 years or older and received single agent IMBRUVICA or chlorambucil. HELIOS included 574 randomized patients with previously treated CLL or SLL who received IMBRUVICA in combination with BR or placebo in combination with BR. iLLUMINATE included 228 randomized patients with treatment naïve CLL/SLL who were 65 years or older or with coexisting medical conditions and received IMBRUVICA in combination with obinutuzumab or chlorambucil in combination with obinutuzumab. E1912 included 510 patients with previously untreated CLL/SLL who were 70 years or younger and received IMBRUVICA in combination with rituximab or received fludarabine, cyclophosphamide, and rituximab (FCR).

The most common adverse reactions in patients with CLL/SLL receiving IMBRUVICA (\geq 30%) were thrombocytopenia, diarrhea, fatigue, musculoskeletal pain, neutropenia, rash, anemia, bruising, and nausea.

Four to 10 percent of patients with CLL/SLL receiving IMBRUVICA discontinued treatment due to adverse reactions. These included pneumonia, hemorrhage, atrial fibrillation, neutropenia, arthralgia, rash, and thrombocytopenia. Adverse reactions leading to dose reduction occurred in approximately 9% of patients.

Study 1102

Adverse reactions and laboratory abnormalities from Study 1102 (N=51) using single agent IMBRUVICA 420 mg daily in patients with previously treated CLL/SLL occurring at a rate of \geq 10% with a median duration of treatment of 15.6 months are presented in [Tables 3 and 4](#).

Table 3: Non-Hematologic Adverse Reactions in \geq 10% of Patients with CLL/SLL (N=51) in Study 1102

Body System	Adverse Reaction	All Grades (%)	Grade 3 or Higher (%)
Gastrointestinal disorders	Diarrhea	59	4
	Constipation	22	2
	Nausea	20	2
	Stomatitis	20	0
	Vomiting	18	2
	Abdominal pain	14	0
	Dyspepsia	12	0
Skin and subcutaneous tissue disorders	Bruising	51	2
	Rash	25	0
	Petechiae	16	0

Body System	Adverse Reaction	All Grades (%)	Grade 3 or Higher (%)
Infections and infestations	Upper respiratory tract infection	47	2
	Sinusitis	22	6
	Skin infection	16	6
	Pneumonia	12	10
	Urinary tract infection	12	2
General disorders and administration site conditions	Fatigue	33	6
	Pyrexia	24	2
	Peripheral edema	22	0
	Asthenia	14	6
	Chills	12	0
Musculoskeletal and connective tissue disorders	Musculoskeletal pain	25	6
	Arthralgia	24	0
	Muscle spasms	18	2
Respiratory, thoracic and mediastinal disorders	Cough	22	0
	Oropharyngeal pain	14	0
	Dyspnea	12	0
Nervous system disorders	Dizziness	20	0
	Headache	18	2
Vascular disorders	Hypertension	16	8
Metabolism and nutrition disorders	Decreased appetite	16	2
Neoplasms benign, malignant, unspecified	Second malignancies	10	2 [†]

[†]One patient death due to histiocytic sarcoma.

Table 4: Treatment-Emergent* Hematologic Laboratory Abnormalities in Patients with CLL/SLL (N=51) in Study 1102

	Percent of Patients (N=51)	
	All Grades (%)	Grade 3 or 4 (%)
Platelets decreased	69	12
Neutrophils decreased	53	26
Hemoglobin decreased	43	0

* Based on laboratory measurements per IWCLL criteria and adverse reactions.

Treatment-emergent Grade 4 thrombocytopenia (8%) and neutropenia (12%) occurred in patients.

RESONATE

Adverse reactions and laboratory abnormalities described below in Tables 5 and 6 reflect exposure to IMBRUVICA with a median duration of 8.6 months and exposure to ofatumumab with a median of 5.3 months in RESONATE in patients with previously treated CLL/SLL.

Table 5: Adverse Reactions Reported in $\geq 10\%$ of Patients in the IMBRUVICA Treated Arm in Patients with CLL/SLL in RESONATE

Body System Adverse Reaction	IMBRUVICA (N=195)		Ofatumumab (N=191)	
	All Grades (%)	Grade 3 or Higher (%)	All Grades (%)	Grade 3 or Higher (%)
Gastrointestinal disorders				
Diarrhea	48	4	18	2
Nausea	26	2	18	0
Stomatitis*	17	1	6	1
Constipation	15	0	9	0
Vomiting	14	0	6	1
Musculoskeletal and connective tissue disorders				
Musculoskeletal pain*	28	2	18	1
Arthralgia	17	1	7	0
Muscle spasms	13	0	8	0
Skin and subcutaneous tissue disorders				
Rash*	24	3	13	0
Petechiae	14	0	1	0
Bruising*	12	0	1	0
General disorders and administration site conditions				
Pyrexia	24	2	15	2 [†]
Respiratory, thoracic and mediastinal disorders				
Cough	19	0	23	1
Dyspnea	12	2	10	1
Infections and infestations				
Upper respiratory tract infection	16	1	11	2 [†]
Pneumonia*	15	12 [†]	13	10 [†]
Sinusitis*	11	1	6	0
Urinary tract infection	10	4	5	1

Body System Adverse Reaction	IMBRUVICA (N=195)		Ofatumumab (N=191)	
	All Grades (%)	Grade 3 or Higher (%)	All Grades (%)	Grade 3 or Higher (%)
Nervous system disorders				
Headache	14	1	6	0
Dizziness	11	0	5	0
Injury, poisoning and procedural complications				
Contusion	11	0	3	0
Eye disorders				
Vision blurred	10	0	3	0

The body system and individual ADR terms are sorted in descending frequency order in the IMBRUVICA arm.

* Includes multiple ADR terms

† Includes 3 events of pneumonia with fatal outcome in each arm, and 1 event of pyrexia and upper respiratory tract infection with a fatal outcome in the ofatumumab arm.

Table 6: Treatment-Emergent Hematologic Laboratory Abnormalities in Patients with CLL/SLL in RESONATE

	IMBRUVICA (N=195)		Ofatumumab (N=191)	
	All Grades (%)	Grade 3 or 4 (%)	All Grades (%)	Grade 3 or 4 (%)
Neutrophils decreased	51	23	57	26
Platelets decreased	52	5	45	10
Hemoglobin decreased	36	0	21	0

Treatment-emergent Grade 4 thrombocytopenia (2% in the IMBRUVICA arm vs 3% in the ofatumumab arm) and neutropenia (8% in the IMBRUVICA arm vs 8% in the ofatumumab arm) occurred in patients.

RESONATE-2

Adverse reactions and laboratory abnormalities described below in [Tables 7](#) and [Table 8](#) reflect exposure to IMBRUVICA with a median duration of 17.4 months. The median exposure to chlorambucil was 7.1 months in RESONATE-2.

Table 7: Adverse Reactions Reported in $\geq 10\%$ of Patients in the IMBRUVICA Treated Arm in Patients with CLL/SLL in RESONATE-2

Body System Adverse Reaction	IMBRUVICA (N=135)		Chlorambucil (N=132)	
	All Grades (%)	Grade 3 or Higher (%)	All Grades (%)	Grade 3 or Higher (%)
Gastrointestinal disorders				
Diarrhea	42	4	17	0
Nausea	22	1	39	1
Constipation	16	1	16	0
Stomatitis*	14	1	4	1
Vomiting	13	0	20	1
Abdominal pain	13	3	11	1
Dyspepsia	11	0	2	0
Musculoskeletal and connective tissue disorders				
Musculoskeletal pain*	36	4	20	0
Arthralgia	16	1	7	1
Muscle spasms	11	0	5	0
General disorders and administration site conditions				
Fatigue	30	1	38	5
Peripheral edema	19	1	9	0
Pyrexia	17	0	14	2
Respiratory, thoracic and mediastinal disorders				
Cough	22	0	15	0
Dyspnea	10	1	10	0
Skin and subcutaneous tissue disorders				
Rash*	21	4	12	2
Bruising*	19	0	7	0
Eye disorders				
Dry eye	17	0	5	0
Lacrimation increased	13	0	6	0
Vision blurred	13	0	8	0
Visual acuity reduced	11	0	2	0
Infections and infestations				
Upper respiratory tract infection	17	2	17	2
Skin infection*	15	2	3	1
Pneumonia*	14	8	7	4
Urinary tract infections	10	1	8	1

Body System Adverse Reaction	IMBRUVICA (N=135)		Chlorambucil (N=132)	
	All Grades (%)	Grade 3 or Higher (%)	All Grades (%)	Grade 3 or Higher (%)
Vascular disorders				
Hypertension*	14	4	1	0
Nervous system disorders				
Headache	12	1	10	2
Dizziness	11	0	12	1
Investigations				
Weight decreased	10	0	12	0

Subjects with multiple events for a given ADR term are counted once only for each ADR term.

The body system and individual ADR terms are sorted in descending frequency order in the IMBRUVICA arm.

* Includes multiple ADR terms

Table 8: Treatment-Emergent Hematologic Laboratory Abnormalities in Patients with CLL/SLL in RESONATE-2

	IMBRUVICA (N=135)		Chlorambucil (N=132)	
	All Grades (%)	Grade 3 or 4 (%)	All Grades (%)	Grade 3 or 4 (%)
Neutrophils Decreased	55	28	67	31
Platelets Decreased	47	7	58	14
Hemoglobin Decreased	36	0	39	2

Treatment-emergent Grade 4 thrombocytopenia (1% in the IMBRUVICA arm vs 3% in the chlorambucil arm) and neutropenia (11% in the IMBRUVICA arm vs 12% in the chlorambucil arm) occurred in patients.

HELIOS

Adverse reactions described below in [Table 9](#) reflect exposure to IMBRUVICA + BR with a median duration of 14.7 months and exposure to placebo + BR with a median of 12.8 months in HELIOS in patients with previously treated CLL/SLL.

Table 9: Adverse Reactions Reported in at Least 10% of Patients and at Least 2% Greater in the IMBRUVICA Arm in Patients with CLL/SLL in HELIOS

Body System Adverse Reaction	IMBRUVICA + BR (N=287)		Placebo + BR (N=287)	
	All Grades (%)	Grade 3 or Higher (%)	All Grades (%)	Grade 3 or Higher (%)
Blood and lymphatic system disorders				
Neutropenia*	66	61	60	56 [†]
Thrombocytopenia*	34	16	26	16

Gastrointestinal disorders				
Diarrhea	36	2	23	1
Abdominal pain	12	1	8	<1
Skin and subcutaneous tissue disorders				
Rash *	32	4	25	1
Bruising *	20	<1	8	<1
Musculoskeletal and connective tissue disorders				
Musculoskeletal pain*	29	2	20	0
Muscle spasms	12	<1	5	0
General disorders and administration site conditions				
Pyrexia	25	4	22	2
Vascular disorders				
Hemorrhage*	19	2 [†]	9	1
Hypertension *	11	5	5	2
Infections and infestations				
Bronchitis	13	2	10	3
Skin infection*	10	3	6	2
Metabolism and nutrition disorders				
Hyperuricemia	10	2	6	0

The body system and individual ADR terms are sorted in descending frequency order in the IMBRUVICA arm.

* Includes multiple ADR terms

<1 used for frequency above 0 and below 0.5%

† Includes 2 events of hemorrhage with fatal outcome in the IMBRUVICA arm and 1 event of neutropenia with a fatal outcome in the placebo + BR arm.

Atrial fibrillation of any grade occurred in 7% of patients treated with IMBRUVICA + BR and 2% of patients treated with placebo + BR. The frequency of Grade 3 and 4 atrial fibrillation was 3% in patients treated with IMBRUVICA + BR and 1% in patients treated with placebo + BR.

iLLUMINATE

Adverse reactions described below in [Table 10](#) reflect exposure to IMBRUVICA + obinutuzumab with a median duration of 29.3 months and exposure to chlorambucil + obinutuzumab with a median of 5.1 months in *iLLUMINATE* in patients with previously untreated CLL/SLL.

**Table 10: Adverse Reactions Reported in at Least 10% of Patients
in the IMBRUVICA Arm in Patients with CLL/SLL in iLLUMINATE**

Body System Adverse Reaction	IMBRUVICA + Obinutuzumab (N=113)		Chlorambucil + Obinutuzumab (N=115)	
	All Grades (%)	Grade 3 or Higher (%)	All Grades (%)	Grade 3 or Higher (%)
Blood and lymphatic system disorders				
Neutropenia*	48	39	64	48
Thrombocytopenia*	36	19	28	11
Anemia	17	4	25	8
Skin and subcutaneous tissue disorders				
Rash*	36	3	11	0
Bruising*	32	3	3	0
Gastrointestinal disorders				
Diarrhea	34	3	10	0
Constipation	16	0	12	1
Nausea	12	0	30	0
Musculoskeletal and connective tissue disorders				
Musculoskeletal pain*	33	1	23	3
Arthralgia	22	1	10	0
Muscle spasms	13	0	6	0
Respiratory, thoracic and mediastinal disorders				
Cough	27	1	12	0
Injury, poisoning and procedural complications				
Infusion related reaction	25	2	58	8
Vascular disorders				
Hemorrhage*	25	1	9	0
Hypertension*	17	4	4	3
General disorders and administration site conditions				
Pyrexia	19	2	26	1
Fatigue	18	0	17	2
Peripheral edema	12	0	7	0
Infections and infestations				
Pneumonia*	16	9	9	4 [†]

Upper respiratory tract infection	14	1	6	0
Skin infection*	13	1	3	0
Urinary tract infection	12	3	7	1
Nasopharyngitis	12	0	3	0
Conjunctivitis	11	0	2	0
Metabolism and nutrition disorders				
Hyperuricemia	13	1	0	0
Cardiac disorders				
Atrial fibrillation	12	5	0	0
Psychiatric disorders				
Insomnia	12	0	4	0

The body system and individual ADR terms are sorted in descending frequency order in the IMBRUVICA arm.

* Includes multiple ADR terms

† Includes one event with a fatal outcome.

E1912

Adverse reactions described below in [Table 11](#) reflect exposure to IMBRUVICA + rituximab with a median duration of 34.3 months and exposure to FCR with a median of 4.7 months in E1912 in patients with previously untreated CLL/SLL who were 70 years or younger.

Table 11: Adverse Reactions Reported in at Least 15% of Patients in the IMBRUVICA Arm in Patients with CLL/SLL in E1912

Body System Adverse Reaction	IMBRUVICA + Rituximab (N=352)		Fludarabine + Cyclophosphamide + Rituximab (N=158)	
	All Grades (%)	Grade 3 or Higher (%)	All Grades (%)	Grade 3 or Higher (%)
General disorders and administration site conditions				
Fatigue	80	2	78	3
Peripheral edema	28	1	17	0
Pyrexia	27	1	27	1
Pain	23	2	8	0
Musculoskeletal and connective tissue disorders				
Musculoskeletal pain*	61	5	35	2
Arthralgia	41	5	10	1
Gastrointestinal disorders				
Diarrhea	53	4	27	1
Nausea	40	1	64	1

Stomatitis*	22	1	8	1
Abdominal pain*	19	2	10	1
Vomiting	18	2	28	0
Constipation	17	0	32	0
Skin and subcutaneous tissue disorders				
Rash*	49	4	29	5
Bruising*	36	1	4	1
Vascular disorders				
Hypertension*	42	19	22	6
Hemorrhage*	31	2	8	1
Nervous system disorders				
Headache	40	1	27	1
Dizziness	21	1	13	1
Peripheral neuropathy*	19	1	13	1
Respiratory, thoracic and mediastinal disorders				
Cough	32	0	25	0
Dyspnea	22	2	21	1
Infections and infestations				
Upper respiratory tract infection	29	1	19	2
Skin infection*	16	1	3	1
Metabolism and nutrition disorders				
Hyperuricemia	19	1	4	0
Decreased appetite	15	0	20	1
Psychiatric disorders				
Insomnia	16	1	19	1

The body system and individual ADR terms are sorted in descending frequency order in the IMBRUVICA arm.

* Includes multiple ADR terms

Table 12: Select Laboratory Abnormalities ($\geq 15\%$ Any Grade), New or Worsening from Baseline in Patients Receiving IMBRUVICA (E1912)

	IMBRUVICA + Rituximab (N=352)		Fludarabine + Cyclophosphamide + Rituximab (N=158)	
	All Grades (%)	Grade 3 or 4 (%)	All Grades (%)	Grade 3 or 4 (%)
Hematology abnormalities				
Neutrophils decreased	53	30	70	44

Platelets decreased	43	7	69	25
Hemoglobin decreased	26	0	51	2
Chemistry abnormalities				
Creatinine increased	38	1	17	1
Bilirubin increased	30	2	15	0
AST increased	25	3	23	<1

Based on laboratory measurements per IWCLL criteria

Waldenström's Macroglobulinemia and Marginal Zone Lymphoma

The data described below reflect exposure to IMBRUVICA in three single-arm open-label clinical trials (Study 1118, Study 1121, and INNOVATE monotherapy arm) and one randomized controlled trial (INNOVATE) in patients with WM or MZL, including a total n=307 patients overall and n=232 patients exposed to IMBRUVICA. Study 1118 included 63 patients with previously treated WM who received single agent IMBRUVICA. Study 1121 included 63 patients with previously treated MZL who received single agent IMBRUVICA. INNOVATE included 150 patients with treatment naïve or previously treated WM who received IMBRUVICA or placebo in combination with rituximab. The INNOVATE monotherapy arm included 31 patients with previously treated WM who failed prior rituximab-containing therapy and received IMBRUVICA.

The most common adverse reactions in Studies 1118, 1121, and INNOVATE ($\geq 20\%$) were thrombocytopenia, diarrhea, bruising, neutropenia, musculoskeletal pain, hemorrhage, anemia, rash, fatigue, and nausea.

Seven percent of patients receiving IMBRUVICA across Studies 1118, 1121, and INNOVATE discontinued treatment due to adverse reactions. The most common adverse reactions leading to discontinuation were atrial fibrillation, interstitial lung disease, diarrhea and rash. Adverse reactions leading to dose reduction occurred in 13% of patients.

Study 1118 and INNOVATE Monotherapy Arm

Adverse reactions and laboratory abnormalities described below in [Table 13](#) and [Table 14](#) reflect exposure to IMBRUVICA with a median duration of 11.7 months in Study 1118 and 33 months in the INNOVATE Monotherapy Arm.

Table 13: Non-Hematologic Adverse Reactions in $\geq 10\%$ in Patients with WM in Study 1118 and the INNOVATE Monotherapy Arm (N=94)

Body System	Adverse Reaction	All Grades (%)	Grade 3 or Higher (%)
Gastrointestinal disorders	Diarrhea	38	2
	Nausea	21	0
	Stomatitis*	15	0
	Constipation	12	1
	Gastroesophageal reflux disease	12	0
Skin and subcutaneous tissue disorders	Bruising*	28	1
	Rash*	21	1

Body System	Adverse Reaction	All Grades (%)	Grade 3 or Higher (%)
Vascular disorders	Hemorrhage*	28	0
	Hypertension*	14	4
General disorders and administrative site conditions	Fatigue	18	2
	Pyrexia	12	2
Musculoskeletal and connective tissue disorders	Musculoskeletal pain*	21	0
	Muscle spasms	19	0
Infections and infestations	Upper respiratory tract infection	19	0
	Skin infection*	18	3
	Sinusitis*	16	0
	Pneumonia*	13	5
Nervous system disorders	Headache	14	0
	Dizziness	13	0
Respiratory, thoracic and mediastinal disorders	Cough	13	0

The body system and individual ADR preferred terms are sorted in descending frequency order.

* Includes multiple ADR terms.

Table 14: Treatment-Emergent Hematologic Laboratory Abnormalities in Patients with WM in Study 1118 and the INNOVATE Monotherapy Arm (N=94)

	Percent of Patients (N=94)	
	All Grades (%)	Grade 3 or 4 (%)
Platelets Decreased	38	11
Neutrophils Decreased	43	16
Hemoglobin Decreased	21	6

Treatment-emergent Grade 4 thrombocytopenia (4%) and neutropenia (7%) occurred in patients.

INNOVATE

Adverse reactions described below in [Table 15](#) reflect exposure to IMBRUVICA + R with a median duration of 25.8 months and exposure to placebo + R with a median duration of 15.5 months in patients with treatment naïve or previously treated WM in INNOVATE.

Table 15: Adverse Reactions Reported in at Least 10% of Patients and at Least 2% Greater in the IMBRUVICA Arm in Patients with WM in INNOVATE

Body System Adverse Reaction	IMBRUVICA + R (N=75)		Placebo + R (N=75)	
	All Grades (%)	Grade 3 or Higher (%)	All Grades (%)	Grade 3 or Higher (%)
Skin and subcutaneous tissue disorders				
Bruising*	37	1	5	0
Rash*	24	1	11	0

Musculoskeletal and connective tissue disorders				
Musculoskeletal pain*	35	4	21	3
Arthralgia	24	3	11	1
Muscle spasms	17	0	12	1
Vascular disorders				
Hemorrhage*	32	3	17	4 [†]
Hypertension*	20	13	5	4
Gastrointestinal disorders				
Diarrhea	28	0	15	1
Nausea	21	0	12	0
Dyspepsia	16	0	1	0
Constipation	13	1	11	1
Infections and infestations				
Pneumonia*	19	13	5	3
Skin infection*	17	3	3	0
Urinary tract infection	13	0	0	0
Bronchitis	12	3	7	0
Influenza	12	0	7	1
Viral upper respiratory tract infection	11	0	7	0
General disorders and administration site conditions				
Peripheral edema	17	0	12	1
Respiratory, thoracic, and mediastinal disorders				
Cough	17	0	11	0
Blood and lymphatic system disorders				
Neutropenia*	16	12	11	4
Cardiac disorders				
Atrial fibrillation	15	12	3	1
Nervous system disorders				
Dizziness	11	0	7	0
Psychiatric disorders				
Insomnia	11	0	4	0
Metabolism and nutrition disorders				
Hypokalemia	11	0	1	1

The body system and individual ADR preferred terms are sorted in descending frequency order.

* Includes multiple ADR terms.

† Includes one event with a fatal outcome.

Grade 3 or 4 infusion related reactions were observed in 1% of patients treated with IR.

Study 1121

Adverse reactions and laboratory abnormalities described below in [Table 16](#) and [Table 17](#) reflect exposure to IMBRUVICA with a median duration of 11.6 months in Study 1121.

Table 16: Non-Hematologic Adverse Reactions in $\geq 10\%$ in Patients with MZL in Study 1121 (N=63)

Body System	Adverse Reaction	All Grades (%)	Grade 3 or Higher (%)
General disorders and administrative site conditions	Fatigue	44	6
	Peripheral edema	24	2
	Pyrexia	17	2
Gastrointestinal disorders	Diarrhea	43	5
	Nausea	25	0
	Dyspepsia	19	0
	Stomatitis*	17	2
	Abdominal pain	16	2
	Constipation	14	0
	Abdominal pain upper	13	0
	Vomiting	11	2
Skin and subcutaneous tissue disorders	Bruising *	41	0
	Rash*	29	5
	Pruritus	14	0
Musculoskeletal and connective tissue disorders	Musculoskeletal pain*	40	3
	Arthralgia	24	2
	Muscle spasms	19	3
Infections and infestations	Upper respiratory tract infection	21	0
	Sinusitis*	19	0
	Bronchitis	11	0
	Pneumonia*	11	10
Metabolism and nutrition disorders	Decreased appetite	16	2
	Hyperuricemia	16	0
	Hypoalbuminemia	14	0
	Hypokalemia	13	0
Vascular disorders	Hemorrhage*	30	2 [†]
	Hypertension*	14	5
Respiratory, thoracic and mediastinal disorders	Cough	22	2
	Dyspnea	21	2
Nervous system disorders	Dizziness	19	0
	Headache	13	0
Psychiatric disorders	Anxiety	16	2

The body system and individual ADR preferred terms are sorted in descending frequency order.

* Includes multiple ADR terms.

† Includes one event with a fatal outcome.

Table 17: Treatment-Emergent Hematologic Laboratory Abnormalities in Patients with MZL in Study 1121 (N=63)

	Percent of Patients (N=63)	
	All Grades (%)	Grade 3 or 4 (%)
Platelets decreased	49	6
Hemoglobin decreased	43	13
Neutrophils decreased	22	13

Treatment-emergent Grade 4 thrombocytopenia (3%) and neutropenia (6%) occurred in patients.

Chronic Graft versus Host Disease

The data described below reflect exposure to IMBRUVICA in an open-label clinical trial (Study 1129) that included 42 patients with cGVHD after failure of first line corticosteroid therapy and required additional therapy.

The most common adverse reactions in the cGVHD trial ($\geq 20\%$) were fatigue, bruising, diarrhea, thrombocytopenia, stomatitis, muscle spasms, nausea, hemorrhage, anemia, and pneumonia. Atrial fibrillation occurred in one patient (2%) which was Grade 3.

Twenty-four percent of patients receiving IMBRUVICA in the cGVHD trial discontinued treatment due to adverse reactions. The most common adverse reactions leading to discontinuation were fatigue and pneumonia. Adverse reactions leading to dose reduction occurred in 26% of patients.

Adverse reactions and laboratory abnormalities described below in [Table 18](#) and [Table 19](#) reflect exposure to IMBRUVICA with a median duration of 4.4 months in the cGVHD trial.

Table 18: Non-Hematologic Adverse Reactions in $\geq 10\%$ of Patients with cGVHD (N=42)

Body System	Adverse Reaction	All Grades (%)	Grade 3 or Higher (%)
General disorders and administration site conditions	Fatigue	57	12
	Pyrexia	17	5
	Edema peripheral	12	0
Skin and subcutaneous tissue disorders	Bruising*	40	0
	Rash*	12	0
Gastrointestinal disorders	Diarrhea	36	10
	Stomatitis*	29	2
	Nausea	26	0
	Constipation	12	0
Musculoskeletal and connective tissue disorders	Muscle spasms	29	2
	Musculoskeletal pain*	14	5
Vascular disorders	Hemorrhage*	26	0

Infections and infestations	Pneumonia*	21	14 [†]
	Upper respiratory tract infection	19	0
	Sepsis*	10	10
Nervous system disorders	Headache	17	5
Injury, poisoning and procedural complications	Fall	17	0
Respiratory, thoracic and mediastinal disorders	Cough	14	0
	Dyspnea	12	2
Metabolism and nutrition disorders	Hypokalemia	12	7

The system organ class and individual ADR preferred terms are sorted in descending frequency order.

* Includes multiple ADR terms.

† Includes 2 events with a fatal outcome.

Table 19: Treatment-Emergent Hematologic Laboratory Abnormalities in Patients with cGVHD (N=42)

	Percent of Patients (N=42)	
	All Grades (%)	Grade 3 or 4 (%)
Platelets decreased	33	0
Neutrophils decreased	10	10
Hemoglobin decreased	24	2

Treatment-emergent Grade 4 neutropenia occurred in 2% of patients.

Additional Important Adverse Reactions

Cardiovascular Events

Data on cardiovascular events are based on randomized controlled trials with IMBRUVICA (n=2,115; median treatment duration of 19.1 months for 1,157 patients treated with IMBRUVICA and 5.3 months for 958 patients in the control arm). The incidence of ventricular tachyarrhythmias (ventricular extrasystoles, ventricular arrhythmias, ventricular fibrillation, ventricular flutter, and ventricular tachycardia) of any grade was 1.0% versus 0.4% and of Grade 3 or greater was 0.3% versus 0% in patients treated with IMBRUVICA compared to patients in the control arm. In addition, the incidence of atrial fibrillation and atrial flutter of any grade was 8.4% versus 1.6% and for Grade 3 or greater was 4.0% versus 0.5% in patients treated with IMBRUVICA compared to patients in the control arm.

The incidence of ischemic cerebrovascular events (cerebrovascular accidents, ischemic stroke, cerebral ischemia, and transient ischemic attack) of any grade was 1% versus 0.4% and Grade 3 or greater was 0.5% versus 0.2% in patients treated with IMBRUVICA compared to patients in the control arm, respectively.

Diarrhea

In randomized controlled trials (n=2,115; median treatment duration of 19.1 months for 1,157 patients treated with IMBRUVICA and 5.3 months for 958 patients in the control arm),

diarrhea of any grade occurred at a rate of 43% of patients treated with IMBRUVICA compared to 19% of patients in the control arm. Grade 3 diarrhea occurred in 3% versus 1% of IMBRUVICA-treated patients compared to the control arm, respectively. Less than 1% (0.3%) of subjects discontinued IMBRUVICA due to diarrhea compared with 0% in the control arm.

Based on data from 1,605 of these patients, the median time to first onset was 21 days (range, 0 to 708) versus 46 days (range, 0 to 492) for any grade diarrhea and 117 days (range, 3 to 414) versus 194 days (range, 11 to 325) for Grade 3 diarrhea in IMBRUVICA-treated patients compared to the control arm, respectively. Of the patients who reported diarrhea, 85% versus 89% had complete resolution, and 15% versus 11% had not reported resolution at time of analysis in IMBRUVICA-treated patients compared to the control arm, respectively. The median time from onset to resolution in IMBRUVICA-treated subjects was 7 days (range, 1 to 655) versus 4 days (range, 1 to 367) for any grade diarrhea and 7 days (range, 1 to 78) versus 19 days (range, 1 to 56) for Grade 3 diarrhea in IMBRUVICA-treated subjects compared to the control arm, respectively.

Visual Disturbance

In randomized controlled trials (n=2,115; median treatment duration of 19.1 months for 1,157 patients treated with IMBRUVICA and 5.3 months for 958 patients in the control arm), blurred vision and decreased visual acuity of any grade occurred in 11% of patients treated with IMBRUVICA (9% Grade 1, 2% Grade 2, no Grade 3 or higher) compared to 6% in the control arm (5% Grade 1 and <1% Grade 2 and 3).

Based on data from 1,605 of these patients, the median time to first onset was 91 days (range, 0 to 617) versus 100 days (range, 2 to 477) in IMBRUVICA-treated patients compared to the control arm, respectively. Of the patients who reported visual disturbances, 60% versus 71% had complete resolution and 40% versus 29% had not reported resolution at the time of analysis in IMBRUVICA-treated patients compared to the control arm, respectively. The median time from onset to resolution was 37 days (range, 1 to 457) versus 26 days (range, 1 to 721) in IMBRUVICA-treated subjects compared to the control arm, respectively.

Long-Term Safety

The safety data from long-term follow-up over 5 years of 1,178 patients (treatment-naïve CLL/SLL n=162, relapsed/refractory CLL/SLL n=646, and relapsed/refractory MCL n=370) treated with IMBRUVICA were analyzed. The median treatment duration for CLL/SLL was 51 months (range, 0.2 to 98 months). The median treatment duration for MCL was 11 months (range, 0 to 87 months). The cumulative rate of hypertension increased over time with prolonged IMBRUVICA treatment. The prevalence for Grade 3 or greater hypertension was 4% (year 0-1), 6% (year 1-2), 8% (year 2-3), 9% (year 3-4), and 9% (year 4-5). The incidence for the 5-year period was 11%.

6.2 Postmarketing Experience

The following adverse reactions have been identified during postapproval use of IMBRUVICA. Because these reactions are reported voluntarily from a population of uncertain size, it is not always possible to reliably estimate their frequency or establish a causal relationship to drug exposure.

- Hepatobiliary disorders: hepatic failure including acute and/or fatal events, hepatic cirrhosis
- Respiratory disorders: interstitial lung disease
- Metabolic and nutrition disorders: tumor lysis syndrome
- Immune system disorders: anaphylactic shock, angioedema, urticaria
- Skin and subcutaneous tissue disorders: Stevens-Johnson Syndrome (SJS), onychoclasia, panniculitis, neutrophilic dermatoses
- Infections: hepatitis B reactivation
- Nervous system disorders: peripheral neuropathy

7 DRUG INTERACTIONS

7.1 Effect of CYP3A Inhibitors on Ibrutinib

The coadministration of IMBRUVICA with a strong or moderate CYP3A inhibitor may increase ibrutinib plasma concentrations [*see Clinical Pharmacology (12.3)*]. Increased ibrutinib concentrations may increase the risk of drug-related toxicity.

Dose modifications of IMBRUVICA are recommended when used concomitantly with posaconazole, voriconazole and moderate CYP3A inhibitors [*see Dosage and Administration (2.3)*].

Avoid concomitant use of other strong CYP3A inhibitors. Interrupt IMBRUVICA if these inhibitors will be used short-term (such as anti-infectives for seven days or less) [*see Dosage and Administration (2.3)*].

Avoid grapefruit and Seville oranges during IMBRUVICA treatment, as these contain strong or moderate inhibitors of CYP3A.

7.2 Effect of CYP3A Inducers on Ibrutinib

The coadministration of IMBRUVICA with strong CYP3A inducers may decrease ibrutinib concentrations. Avoid coadministration with strong CYP3A inducers [*see Clinical Pharmacology (12.3)*].

8 USE IN SPECIFIC POPULATIONS

8.1 Pregnancy

Risk Summary

IMBRUVICA can cause fetal harm based on findings from animal studies. There are no available data on IMBRUVICA use in pregnant women to inform a drug-associated risk of major birth defects and miscarriage. In animal reproduction studies, administration of ibrutinib to pregnant rats and rabbits during the period of organogenesis at exposures up to 2-20 times the clinical doses of 420-560 mg daily produced embryofetal toxicity including structural abnormalities (*see Data*). Advise pregnant women of the potential risk to a fetus.

All pregnancies have a background risk of birth defect, loss, or other adverse outcomes. The estimated background risk of major birth defects and miscarriage for the indicated population is unknown. In the U.S. general population, the estimated background risk of major birth defects and miscarriage in clinically recognized pregnancies is 2-4% and 15-20%, respectively.

Data

Animal Data

Ibrutinib was administered orally to pregnant rats during the period of organogenesis at doses of 10, 40 and 80 mg/kg/day. Ibrutinib at a dose of 80 mg/kg/day was associated with visceral malformations (heart and major vessels) and increased resorptions and post-implantation loss. The dose of 80 mg/kg/day in rats is approximately 14 times the exposure (AUC) in patients with MCL or MZL and 20 times the exposure in patients with CLL/SLL or WM administered the dose of 560 mg daily and 420 mg daily, respectively. Ibrutinib at doses of 40 mg/kg/day or greater was associated with decreased fetal weights. The dose of 40 mg/kg/day in rats is approximately 6 times the exposure (AUC) in patients with MCL administered the dose of 560 mg daily.

Ibrutinib was also administered orally to pregnant rabbits during the period of organogenesis at doses of 5, 15, and 45 mg/kg/day. Ibrutinib at a dose of 15 mg/kg/day or greater was associated with skeletal variations (fused sternbrae) and ibrutinib at a dose of 45 mg/kg/day was associated with increased resorptions and post-implantation loss. The dose of 15 mg/kg/day in rabbits is approximately 2.0 times the exposure (AUC) in patients with MCL and 2.8 times the exposure in patients with CLL/SLL or WM administered the dose of 560 and 420 mg daily, respectively.

8.2 Lactation

Risk Summary

There is no information regarding the presence of ibrutinib or its metabolites in human milk, the effects on the breastfed child, or the effects on milk production. Because of the potential for serious adverse reactions in the breastfed child, advise women not to breastfeed during treatment with IMBRUVICA and for 1 week after the last dose.

8.3 Females and Males of Reproductive Potential

Pregnancy Testing

Verify pregnancy status in females of reproductive potential prior to initiating IMBRUVICA.

Contraception

Females

IMBRUVICA can cause fetal harm when administered to pregnant women [*see Use in Specific Populations (8.1)*]. Advise females of reproductive potential to use effective contraception during treatment with IMBRUVICA and for 1 month after the last dose.

Males

Advise males with female partners of reproductive potential to use effective contraception during treatment with IMBRUVICA and for 1 month following the last dose.

8.4 Pediatric Use

The safety and effectiveness of IMBRUVICA in pediatric patients has not been established.

8.5 Geriatric Use

Of the 1,124 patients in clinical studies of IMBRUVICA, 64% were ≥ 65 years of age, while 23% were ≥ 75 years of age. No overall differences in effectiveness were observed between younger and older patients. Anemia (all grades), pneumonia (Grade 3 or higher), thrombocytopenia, hypertension, and atrial fibrillation occurred more frequently among older patients treated with IMBRUVICA.

8.6 Hepatic Impairment

Avoid use of IMBRUVICA in patients with severe hepatic impairment (Child-Pugh class C). The safety of IMBRUVICA has not been evaluated in patients with mild to severe hepatic impairment by Child-Pugh criteria.

Reduce the recommended dose when administering IMBRUVICA to patients with mild or moderate hepatic impairment (Child-Pugh class A and B). Monitor patients more frequently for adverse reactions of IMBRUVICA [*see Dosage and Administration (2.4), Clinical Pharmacology (12.3)*].

8.7 Plasmapheresis

Management of hyperviscosity in WM patients may include plasmapheresis before and during treatment with IMBRUVICA. Modifications to IMBRUVICA dosing are not required.

10 OVERDOSAGE

There is no specific experience in the management of ibrutinib overdose in patients. One healthy subject experienced reversible Grade 4 hepatic enzyme increases (AST and ALT) after a dose of 1680 mg. Closely monitor patients who ingest more than the recommended dosage and provide appropriate supportive treatment.

11 DESCRIPTION

Ibrutinib is an inhibitor of Bruton's tyrosine kinase (BTK). It is a white to off-white solid with the empirical formula $C_{25}H_{24}N_6O_2$ and a molecular weight 440.50. Ibrutinib is freely soluble in dimethyl sulfoxide, soluble in methanol and practically insoluble in water. The chemical name for ibrutinib is 1-[(3R)-3-[4-amino-3-(4-phenoxyphenyl)-1H-pyrazolo[3,4-d]pyrimidin-1-yl]-1-piperidinyl]-2-propen-1-one and has the following structure:

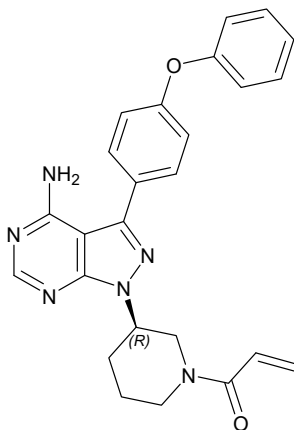

IMBRUVICA (ibrutinib) is available as immediate-release oral capsules and immediate-release oral tablets.

IMBRUVICA (ibrutinib) capsules for oral use are available in the following dosage strengths: 70 mg and 140 mg. Each capsule contains ibrutinib (active ingredient) and the following inactive ingredients: croscarmellose sodium, magnesium stearate, microcrystalline cellulose, sodium lauryl sulfate. The capsule shell contains gelatin, titanium dioxide, yellow iron oxide (70 mg capsule only), and black ink.

IMBRUVICA (ibrutinib) tablets for oral use are available in the following dosage strengths: 140 mg, 280 mg, 420 mg, and 560 mg. Each tablet contains ibrutinib (active ingredient) and the following inactive ingredients: colloidal silicon dioxide, croscarmellose sodium, lactose monohydrate, magnesium stearate, microcrystalline cellulose, povidone, and sodium lauryl sulfate. The film coating for each tablet contains ferrousferrous oxide (140 mg, 280 mg, and 420 mg tablets), polyvinyl alcohol, polyethylene glycol, red iron oxide (280 mg and 560 mg tablets), talc, titanium dioxide, and yellow iron oxide (140 mg, 420 mg, and 560 mg tablets).

12 CLINICAL PHARMACOLOGY

12.1 Mechanism of Action

Ibrutinib is a small-molecule inhibitor of BTK. Ibrutinib forms a covalent bond with a cysteine residue in the BTK active site, leading to inhibition of BTK enzymatic activity. BTK is a signaling molecule of the B-cell antigen receptor (BCR) and cytokine receptor pathways. BTK's role in signaling through the B-cell surface receptors results in activation of pathways necessary for B-cell trafficking, chemotaxis, and adhesion. Nonclinical studies show that ibrutinib inhibits

malignant B-cell proliferation and survival *in vivo* as well as cell migration and substrate adhesion *in vitro*.

12.2 Pharmacodynamics

In patients with recurrent B-cell lymphoma > 90% occupancy of the BTK active site in peripheral blood mononuclear cells was observed up to 24 hours after ibrutinib doses of ≥ 2.5 mg/kg/day (≥ 175 mg/day for average weight of 70 kg).

In vitro Platelet Aggregation

Ibrutinib demonstrated inhibition of collagen-induced platelet aggregation, with IC₅₀ values at 4.6 μ M (2026 ng/mL), 0.8 μ M (352 ng/mL), and 3 μ M (1321 ng/mL) in blood samples from healthy donors, donors taking warfarin, and donors with severe renal dysfunction, respectively. Ibrutinib did not show meaningful inhibition of platelet aggregation for ADP, arachidonic acid, ristocetin, and TRAP-6.

Cardiac Electrophysiology

At a single dose 3 times the maximum recommended dose (1680 mg), IMBRUVICA did not prolong the QT interval to any clinically relevant extent.

12.3 Pharmacokinetics

Ibrutinib exposure increases with doses up to 840 mg (1.5 times the maximum approved recommended dosage) in patients with B-cell malignancies. The mean steady-state AUC (% coefficient of variation) observed in patients at 560 mg with MCL is 865 (69%) ng·h/mL and with MZL is 978 (82%) ng·h/mL, and in patients at 420 mg with CLL/SLL is 708 (71%) ng·h/mL, with WM is 707 (72%) ng·h/mL, and with cGVHD is 1159 (50%) ng·h/mL. Steady-state concentrations of ibrutinib without CYP3A inhibitors were achieved with an accumulation ratio of 1 to 1.6 after 1 week of multiple daily doses of 420 mg or 560 mg.

Absorption

Absolute bioavailability of ibrutinib in fasted condition was 2.9% (90% CI: 2.1, 3.9) in healthy subjects. Ibrutinib is absorbed after oral administration with a median T_{max} of 1 hour to 2 hours.

Effect of Food

The administration of IMBRUVICA with a high-fat and high-calorie meal (800 calories to 1,000 calories with approximately 50% of total caloric content of the meal from fat) increased ibrutinib C_{max} by 2- to 4-fold and AUC by approximately 2-fold, compared with administration of ibrutinib after overnight fasting.

In vitro studies suggest that ibrutinib is not a substrate of p-glycoprotein (P-gp) or breast cancer resistance protein (BCRP).

Distribution

Reversible binding of ibrutinib to human plasma protein *in vitro* was 97.3% with no concentration dependence in the range of 50 ng/mL to 1000 ng/mL. The volume of distribution

(V_d) was 683 L, and the apparent volume of distribution at steady state ($V_{d,ss}/F$) was approximately 10,000 L.

Elimination

Intravenous clearance was 62 L/h in fasted conditions and 76 L/h in fed conditions. In line with the high first-pass effect, the apparent oral clearance is 2000 L/h in fasted conditions and 1000 L/h in fed conditions. The half-life of ibrutinib is 4 hours to 6 hours.

Metabolism

Metabolism is the main route of elimination for ibrutinib. It is metabolized to several metabolites primarily by cytochrome P450 (CYP) 3A and to a minor extent by CYP2D6. The active metabolite, PCI-45227, is a dihydrodiol metabolite with inhibitory activity towards BTK approximately 15 times lower than that of ibrutinib. The range of the mean metabolite to parent ratio for PCI-45227 at steady-state is 1 to 2.8.

Excretion

Ibrutinib, mainly in the form of metabolites, is eliminated primarily via feces. After a single oral administration of radiolabeled ibrutinib, 90% of radioactivity was excreted within 168 hours, with 80% excreted in the feces and less than 10% eliminated in urine. Unchanged ibrutinib accounted for 1% of the radiolabeled excreted dose in feces and none in urine, with the remainder of the excreted dose being metabolites.

Specific Populations

Age and Sex

Age and sex have no clinically meaningful effect on ibrutinib pharmacokinetics.

Patients with Renal Impairment

Mild and moderate renal impairment (creatinine clearance [CL_{Cr}] > 25 mL/min as estimated by Cockcroft-Gault equation) had no influence on the exposure of ibrutinib. No data is available in patients with severe renal impairment (CL_{Cr} < 25 mL/min) or in patients on dialysis.

Patients with Hepatic Impairment

The AUC of ibrutinib increased 2.7-fold in subjects with mild hepatic impairment (Child-Pugh class A), 8.2-fold in subjects with moderate hepatic impairment (Child-Pugh class B) and 9.8-fold in subjects with severe hepatic impairment (Child-Pugh class C) relative to subjects with normal liver function. The C_{max} of ibrutinib increased 5.2-fold in mild hepatic impairment, 8.8-fold in moderate hepatic impairment and 7-fold in severe hepatic impairment relative to subjects with normal liver function [see *Use in Specific Populations (8.6)*].

Drug Interaction Studies

Clinical Studies and Model-Informed Approaches

Effect of CYP3A Inhibitors on Ibrutinib: The coadministration of multiple doses of ketoconazole (strong CYP3A inhibitor) increased the C_{max} of ibrutinib by 29-fold and AUC by 24-fold. The coadministration of multiple doses of voriconazole (strong CYP3A inhibitor) increased steady state C_{max} of ibrutinib by 6.7-fold and AUC by 5.7-fold. Simulations under fed conditions suggest that posaconazole (strong CYP3A inhibitor) may increase the AUC of ibrutinib 3-fold to 10-fold.

The coadministration of multiple doses of erythromycin (moderate CYP3A inhibitor) increased steady state C_{max} of ibrutinib by 3.4-fold and AUC by 3-fold.

Effect of CYP3A Inducers on Ibrutinib: The coadministration of rifampin (strong CYP3A inducer) decreased the C_{max} of ibrutinib by more than 13-fold and AUC by more than 10-fold. Simulations suggest that efavirenz (moderate CYP3A inducer) may decrease the AUC of ibrutinib by 3-fold.

In Vitro Studies

Effect of Ibrutinib on CYP Substrates: In vitro studies suggest that ibrutinib and PCI-45227 are unlikely to inhibit CYP1A2, 2B6, 2C8, 2C9, 2C19, 2D6 or 3A at clinical doses. Both ibrutinib and PCI-45227 are unlikely to induce CYP1A2, CYP2B6 or CYP3A at clinical doses.

Effect of Ibrutinib on Substrates of Transporters: In vitro studies suggest that ibrutinib may inhibit BCRP and P-gp transport at clinical doses. The coadministration of oral P-gp or BCRP substrates with a narrow therapeutic index (e.g., digoxin, methotrexate) with IMBRUVICA may increase their concentrations.

13 NONCLINICAL TOXICOLOGY

13.1 Carcinogenesis, Mutagenesis, Impairment of Fertility

Ibrutinib was not carcinogenic in a 6-month rasH2 mouse study at oral doses up to 2000 mg/kg/day resulting in exposures approximately 23 (males) to 37 (females) times higher than the exposure in humans at a dose of 560 mg daily [see *Warnings and Precautions* (5.6)].

Ibrutinib was not mutagenic in a bacterial mutagenicity (Ames) assay, was not clastogenic in a chromosome aberration assay in mammalian (CHO) cells, nor was it clastogenic in an *in vivo* bone marrow micronucleus assay in mice at doses up to 2000 mg/kg.

Rats were administered oral daily doses of ibrutinib for 4 weeks prior to pairing and during pairing in males and 2 weeks prior to pairing and during pairing in females. Treatment of female rats continued following pregnancy up to gestation day (GD) 7, and treatment of male rats continued until end of study. No effects on fertility or reproductive capacities were observed in male or female rats up to the maximum dose tested, 100 mg/kg/day (Human Equivalent Dose [HED] 16 mg/kg).

14 CLINICAL STUDIES

14.1 Mantle Cell Lymphoma

The safety and efficacy of IMBRUVICA in patients with MCL who have received at least one prior therapy were evaluated in Study PCYC-1104-CA (referred to as Study 1104) (NCT01236391), an open-label, multi-center, single-arm trial of 111 previously treated patients. The median age was 68 years (range, 40 to 84 years), 77% were male, and 92% were White. At baseline, 89% of patients had a baseline ECOG performance status of 0 or 1. The median time since diagnosis was 42 months, and median number of prior treatments was 3 (range, 1 to 5 treatments), including 11% with prior stem cell transplantation. At baseline, 39% of subjects had at least one tumor ≥ 5 cm, 49% had bone marrow involvement, and 54% had extranodal involvement at screening.

IMBRUVICA was administered orally at 560 mg once daily until disease progression or unacceptable toxicity. Tumor response was assessed according to the revised International Working Group (IWG) for non-Hodgkin's lymphoma (NHL) criteria. The primary endpoint in this study was investigator-assessed overall response rate (ORR). Responses to IMBRUVICA are shown in Table 20.

Table 20: Overall Response Rate (ORR) and Duration of Response (DOR) Based on Investigator Assessment in Patients with MCL in Study 1104

	Total (N=111)
ORR (%)	65.8
95% CI (%)	(56.2, 74.5)
CR (%)	17.1
PR (%)	48.6
Median DOR months (95% CI)	17.5 (15.8, NE)

CI = confidence interval; CR = complete response; PR = partial response; NE = not evaluable

An Independent Review Committee (IRC) performed independent reading and interpretation of imaging scans. The IRC review demonstrated an ORR of 69%.

The median time to response was 1.9 months.

Lymphocytosis

Upon initiation of IMBRUVICA, a temporary increase in lymphocyte counts (i.e., $\geq 50\%$ increase from baseline and above absolute lymphocyte count of 5,000/mcL) occurred in 33% of patients in the MCL study. The onset of isolated lymphocytosis occurs during the first few weeks of IMBRUVICA therapy and resolves by a median of 8 weeks.

14.2 Chronic Lymphocytic Leukemia / Small Lymphocytic Lymphoma

The safety and efficacy of IMBRUVICA in patients with CLL/SLL were demonstrated in one uncontrolled trial and five randomized, controlled trials.

Study 1102

Study PCYC-1102-CA (referred to as Study 1102) (NCT01105247), an open-label, multi-center trial, was conducted in 48 previously treated CLL patients. The median age was 67 years (range, 37 to 82 years), 71% were male, and 94% were White. All patients had a baseline ECOG

performance status of 0 or 1. The median time since diagnosis was 80 months and the median number of prior treatments was 4 (range, 1 to 12 treatments). At baseline, 46% of subjects had at least one tumor \geq 5 cm.

IMBRUVICA was administered orally at 420 mg once daily until disease progression or unacceptable toxicity. The ORR and DOR were assessed using a modified version of the International Workshop on CLL Criteria by an Independent Review Committee. The ORR was 58.3% (95% CI: 43.2%, 72.4%), all partial responses. None of the patients achieved a complete response. The DOR ranged from 5.6 to 24.2+ months. The median DOR was not reached.

RESONATE

The RESONATE study (A Randomized, Multicenter, Open-label, Phase 3 Study of the Bruton's Tyrosine Kinase (BTK) Inhibitor Ibrutinib versus Ofatumumab in Patients with Relapsed or Refractory Chronic Lymphocytic Leukemia/Small Lymphocytic Lymphoma) (NCT01578707) was conducted in patients with previously treated CLL or SLL. Patients (n=391) were randomized 1:1 to receive either IMBRUVICA 420 mg daily until disease progression, or unacceptable toxicity or ofatumumab at an initial dose of 300 mg, followed one week later by a dose of 2000 mg weekly for 7 doses and then every 4 weeks for 4 additional doses. Fifty-seven patients randomized to ofatumumab crossed over following progression to receive IMBRUVICA.

The median age was 67 years (range, 30 to 88 years), 68% were male, and 90% were White. All patients had a baseline ECOG performance status of 0 or 1. The trial enrolled 373 patients with CLL and 18 patients with SLL. The median time since diagnosis was 91 months and the median number of prior treatments was 2 (range, 1 to 13 treatments). At baseline, 58% of patients had at least one tumor \geq 5 cm. Thirty-two percent of patients had 17p deletion.

Efficacy results for RESONATE are shown in [Table 21](#) and the Kaplan-Meier curves for PFS, assessed by an IRC according to IWCLL criteria, and OS are shown in [Figure 1](#) and [Figure 2](#), respectively.

Table 21: Efficacy Results in Patients with CLL/SLL in RESONATE

Endpoint	IMBRUVICA N=195	Ofatumumab N=196
Progression Free Survival^b		
Number of events (%)	35 (17.9)	111 (56.6)
Disease progression	26	93
Death events	9	18
Median (95% CI), months	NE	8.1 (7.2, 8.3)
HR (95% CI)	0.22 (0.15, 0.32)	
Overall Survival^a		
Number of deaths (%)	16 (8.2)	33 (16.8)
HR (95% CI)	0.43 (0.24, 0.79)	

Overall Response Rate ^b	42.6%	4.1%
------------------------------------	-------	------

^a Median OS not evaluable for either arm

^b IRC evaluated. All partial responses achieved; none of the patients achieved a complete response.

CI = confidence interval; HR = hazard ratio; NE = not evaluable

Figure 1: Kaplan-Meier Curve of Progression Free Survival (ITT Population) in Patients with CLL/SLL in RESONATE

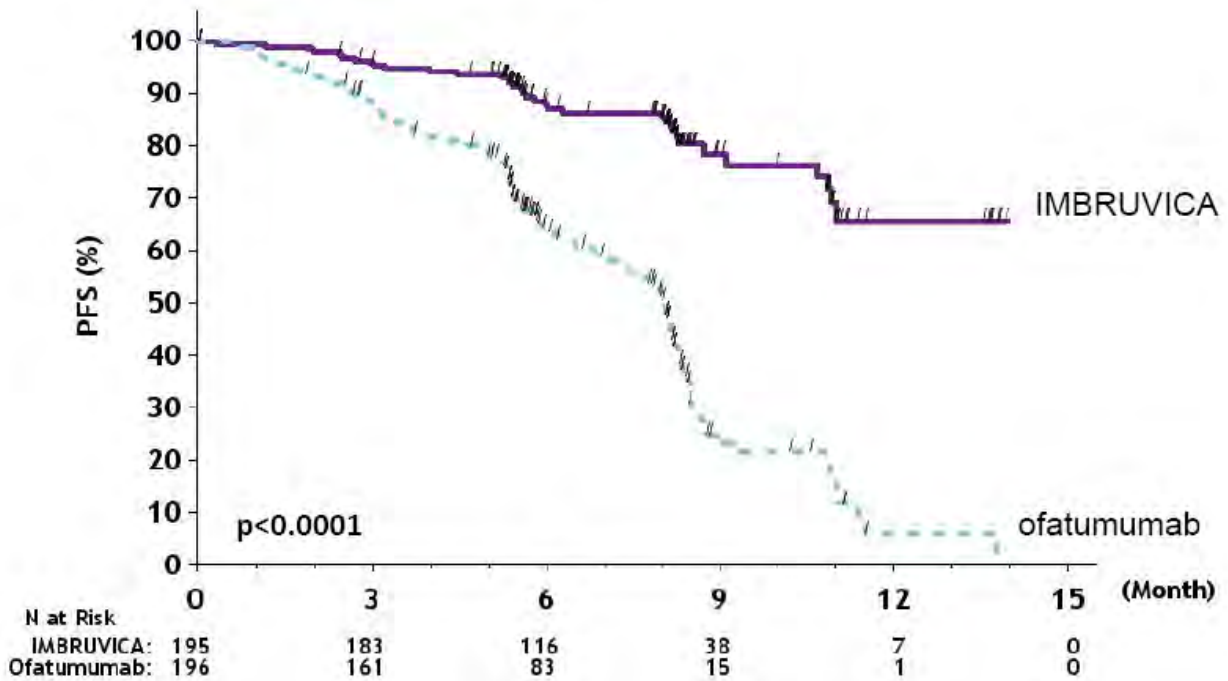
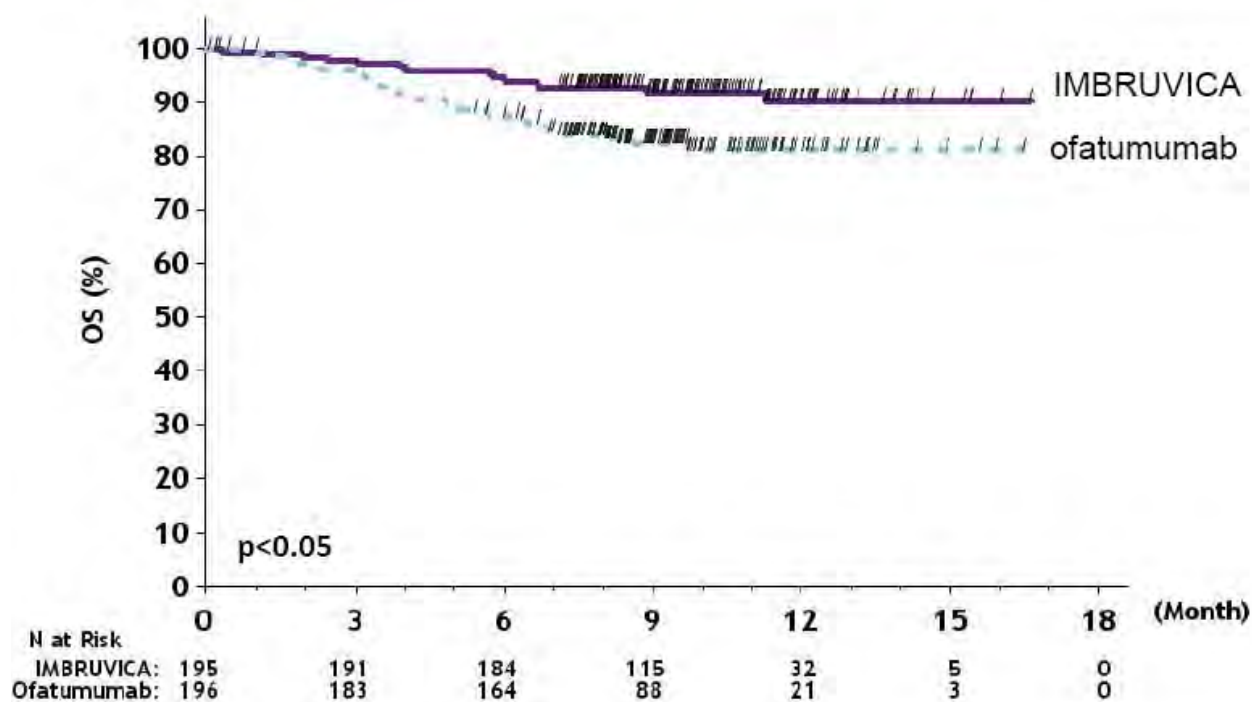

Figure 2: Kaplan-Meier Curve of Overall Survival (ITT Population) in Patients with CLL/SLL in RESONATE



63-Month Follow-Up

With an overall follow-up of 63 months, the median investigator-assessed PFS per IWCLL criteria was 44.1 months [95% CI (38.5, 56.9)] in the IMBRUVICA arm and 8.1 months [95% CI (7.8, 8.3)] in the ofatumumab arm, respectively. Overall response rate as assessed by investigators was 87.2% in the IMBRUVICA arm versus 22.4% in the ofatumumab arm.

CLL/SLL with 17p deletion (del 17p CLL/SLL) in RESONATE

RESONATE included 127 patients with del 17p CLL/SLL. The median age was 67 years (range, 30 to 84 years), 62% were male, and 88% were White. All patients had a baseline ECOG performance status of 0 or 1. PFS and ORR were assessed by an IRC. Efficacy results for del 17p CLL/SLL are shown in [Table 22](#).

Table 22: Efficacy Results in Patients with del 17p CLL/SLL in RESONATE

Endpoint	IMBRUVICA N=63	Ofatumumab N=64
Progression Free Survival^a		
Number of events (%)	16 (25.4)	38 (59.4)
Disease progression	12	31
Death events	4	7
Median (95% CI), months	NE	5.8 (5.3, 7.9)
HR (95% CI)	0.25 (0.14, 0.45)	

Overall Response Rate ^a	47.6%	4.7%
------------------------------------	-------	------

^a IRC evaluated. All partial responses achieved; none of the patients achieved a complete response.
CI = confidence interval; HR = hazard ratio; NE = not evaluable

63-Month Follow-Up

With an overall follow-up of 63 months, the median investigator-assessed PFS in patients with del 17p per IWCLL criteria was 40.6 months [95% CI (25.4, 44.6)] in the IMBRUVICA arm and 6.2 months [95% CI (4.6, 8.1)] in the ofatumumab arm, respectively. Overall response rate as assessed by investigators in patients with del 17p was 88.9% in the IMBRUVICA arm versus 18.8% in the ofatumumab arm.

RESONATE-2

The RESONATE-2 study (A Randomized, Multicenter, Open-label, Phase 3 Study of the Bruton's Tyrosine Kinase Inhibitor PCI-32765 versus Chlorambucil in Patients 65 Years or Older with Treatment-naïve Chronic Lymphocytic Leukemia or Small Lymphocytic Lymphoma) (NCT01722487) was conducted in patients with treatment naïve CLL or SLL who were 65 years of age or older. Patients (n = 269) were randomized 1:1 to receive either IMBRUVICA 420 mg daily until disease progression or unacceptable toxicity, or chlorambucil at a starting dose of 0.5 mg/kg on Days 1 and 15 of each 28-day cycle for a maximum of 12 cycles, with an allowance for inpatient dose increases up to 0.8 mg/kg based on tolerability.

The median age was 73 years (range, 65 to 90 years), 63% were male, and 91% were White. Ninety one percent of patients had a baseline ECOG performance status of 0 or 1 and 9% had an ECOG performance status of 2. The trial enrolled 249 patients with CLL and 20 patients with SLL. At baseline, 20% of patients had 11q deletion. The most common reasons for initiating CLL therapy include: progressive marrow failure demonstrated by anemia and/or thrombocytopenia (38%), progressive or symptomatic lymphadenopathy (37%), progressive or symptomatic splenomegaly (30%), fatigue (27%) and night sweats (25%).

With a median follow-up of 28.1 months, there were 32 observed death events [11 (8.1%) and 21 (15.8%) in IMBRUVICA and chlorambucil treatment arms, respectively]. With 41% of patients switching from chlorambucil to IMBRUVICA, the overall survival analysis in the ITT patient population resulted in a statistically significant HR of 0.44 [95% CI (0.21, 0.92)] and 2-year survival rate estimates of 94.7% [95% CI (89.1, 97.4)] and 84.3% [95% CI (76.7, 89.6)] in the IMBRUVICA and chlorambucil arms, respectively.

Efficacy results for RESONATE-2 are shown in [Table 23](#) and the Kaplan-Meier curve for PFS, assessed by an IRC according to IWCLL criteria is shown in [Figure 3](#).

Table 23: Efficacy Results in Patients with CLL/SLL in RESONATE-2

Endpoint	IMBRUVICA N=136	Chlorambucil N=133
Progression Free Survival^a		

Number of events (%)	15 (11.0)	64 (48.1)
Disease progression	12	57
Death events	3	7
Median (95% CI), months	NE	18.9 (14.1, 22.0)
HR ^b (95% CI)	0.16 (0.09, 0.28)	
Overall Response Rate^a (CR + PR)	82.4%	35.3%
P-value	<0.0001	

^a IRC evaluated; Five subjects (3.7%) in the IMBRUVICA arm and two subjects (1.5%) in the Chlorambucil arm achieved complete response

^b HR = hazard ratio; NE = not evaluable

Figure 3: Kaplan-Meier Curve of Progression-Free Survival (ITT Population) in Patients with CLL/SLL in RESONATE-2

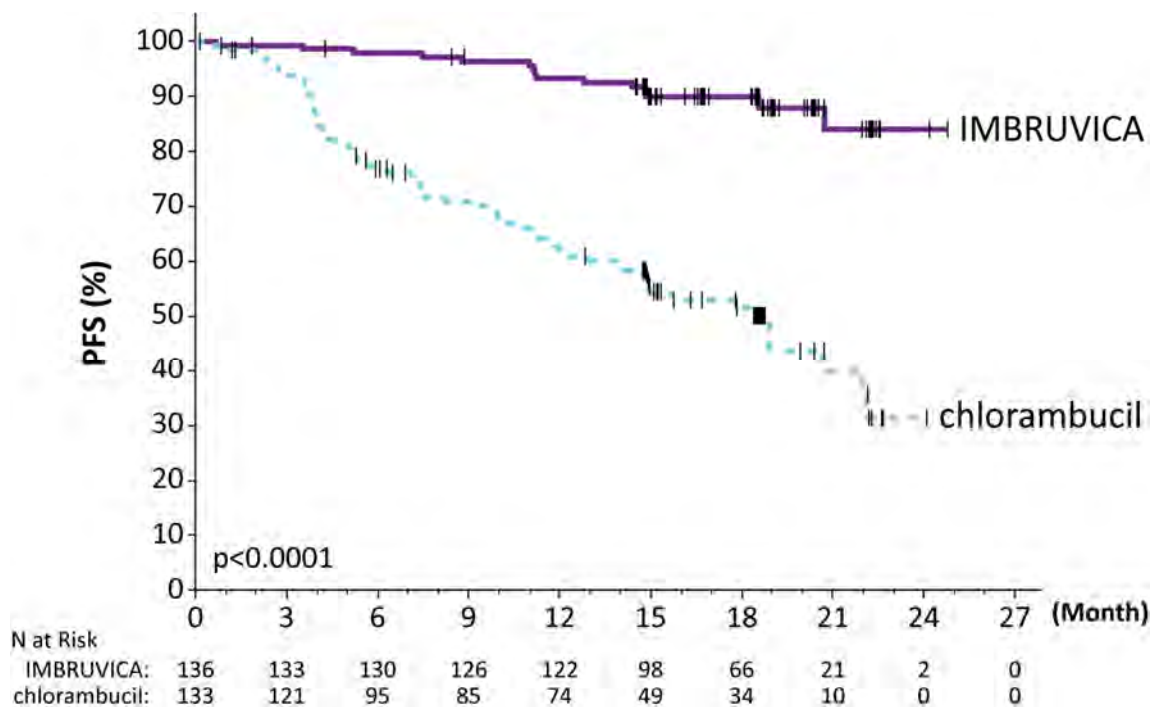

55-Month Follow-Up

With an overall follow-up of 55 months, the median PFS was not reached in the IMBRUVICA arm.

HELIOS

The HELIOS study (Randomized, Double-blind, Placebo-controlled Phase 3 Study of Ibrutinib, a Bruton's Tyrosine Kinase (BTK) Inhibitor, in Combination with Bendamustine and Rituximab (BR) in Subjects with Relapsed or Refractory Chronic Lymphocytic Leukemia/Small Lymphocytic Lymphoma) (NCT01611090) was conducted in patients with previously treated CLL or SLL. Patients (n = 578) were randomized 1:1 to receive either IMBRUVICA 420 mg daily or placebo in combination with BR until disease progression, or unacceptable toxicity. All patients received BR for a maximum of six 28-day cycles. Bendamustine was dosed at 70 mg/m²

infused IV over 30 minutes on Cycle 1, Days 2 and 3, and on Cycles 2-6, Days 1 and 2 for up to 6 cycles, and all patients had a CLCr \geq 40 mL/min at baseline. Rituximab was administered at a dose of 375 mg/m² in the first cycle, Day 1, and 500 mg/m² Cycles 2 through 6, Day 1.

The median age was 64 years (range, 31 to 86 years), 66% were male, and 91% were White. All patients had a baseline ECOG performance status of 0 or 1. The median time since diagnosis was 5.9 years and the median number of prior treatments was 2 (range, 1 to 11 treatments).

At baseline, 56% of patients had at least one tumor \geq 5 cm and 26% presented with del11q.

Efficacy results for HELIOS are shown in [Table 24](#) and the Kaplan-Meier curves for PFS are shown in Figure 4.

Table 24: Efficacy Results in Patients with CLL/SLL in HELIOS

Endpoint	IMBRUVICA + BR N=289	Placebo + BR N=289
Progression Free Survival^a		
Number of events (%)	56 (19.4)	183 (63.3)
Median (95% CI), months	NE	13.3 (11.3, 13.9)
HR (95% CI)	0.20 (0.15, 0.28)	
Overall Response Rate ^a	82.7%	67.8%

^a IRC evaluated, twenty-four subjects (8.3%) in the IMBRUVICA + BR arm and six subjects (2.1%) in the placebo + BR arm achieved complete response

BR = bendamustine and rituximab; CI = confidence interval; HR = hazard ratio; NE = not evaluable

Figure 4: Kaplan-Meier Curve of Progression-Free Survival (ITT Population) in Patients with CLL/SLL in HELIOS

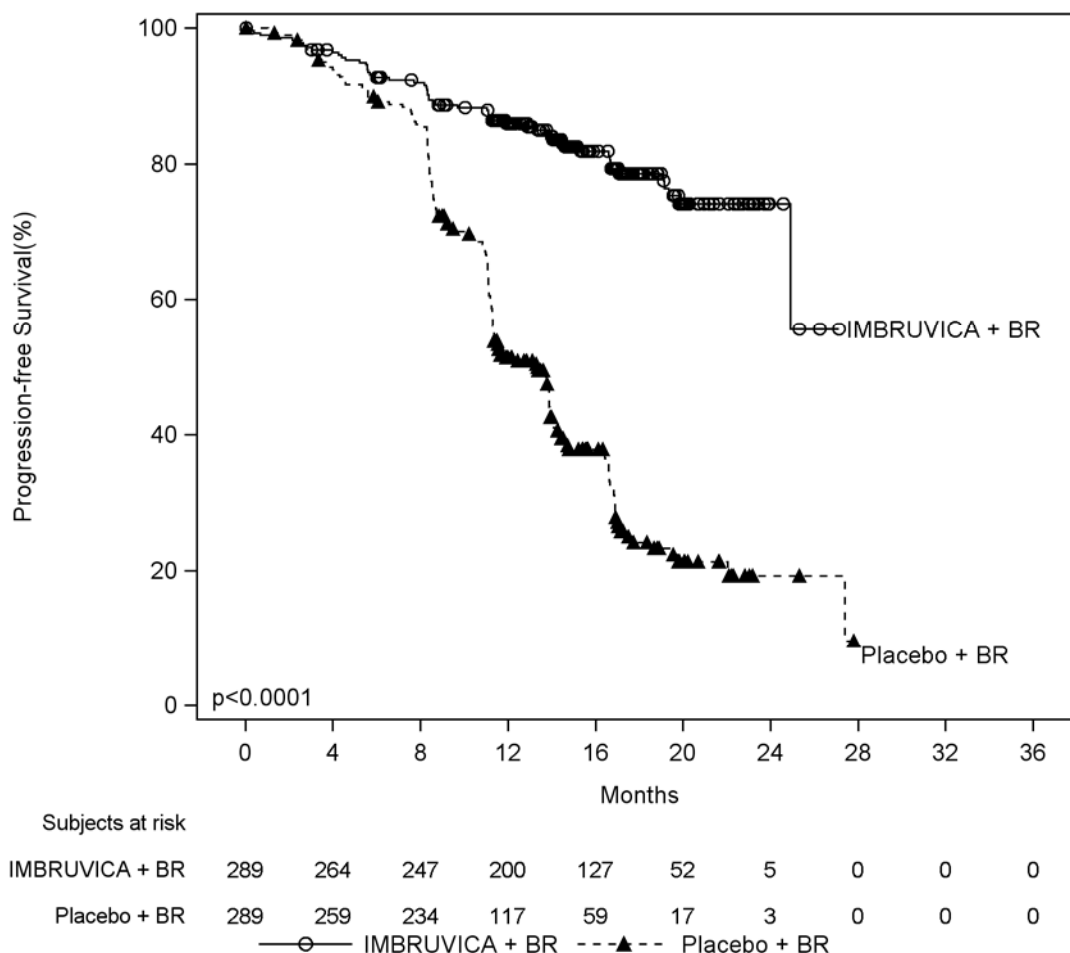

iLLUMINATE

The iLLUMINATE study (a multi-center study of ibrutinib in combination with obinutuzumab versus chlorambucil in combination with obinutuzumab) (NCT02264574) was conducted in patients with treatment naïve CLL or SLL. Patients were 65 years of age or older or < 65 years of age with coexisting medical conditions, reduced renal function as measured by creatinine clearance < 70 mL/min, or presence of del 17p/TP53 mutation. Patients (n = 229) were randomized 1:1 to receive either IMBRUVICA 420 mg daily until disease progression or unacceptable toxicity or chlorambucil at a dose of 0.5 mg/kg on Days 1 and 15 of each 28-day cycle for 6 cycles. In both arms, patients received 1,000 mg of obinutuzumab on Days 1, 8, and 15 of the first cycle, followed by treatment on the first day of 5 subsequent cycles (total of 6 cycles, 28 days each). The first dose of obinutuzumab was divided between Day 1 (100 mg) and Day 2 (900 mg).

The median age was 71 years (range, 40 to 87 years), 64% were male, and 96% were White. All patients had a baseline ECOG performance status of 0 (48%) or 1-2 (52%). The trial enrolled 214 patients with CLL and 15 patients with SLL. At baseline, 65% of patients presented with

CLL/SLL with high risk factors (del 17p/TP53 mutation [18%], del 11q [15%], or unmutated immunoglobulin heavy-chain variable region (unmutated IGHV) [54%]). The most common reasons for initiating CLL therapy included: lymphadenopathy (38%), night sweats (34%), progressive marrow failure (31%), fatigue (29%), splenomegaly (25%), and progressive lymphocytosis (21%).

With a median follow-up time on study of 31 months, efficacy results for iLLUMINATE assessed by an IRC according to IWCLL criteria are shown in [Table 25](#), and the Kaplan-Meier curve for PFS is shown in [Figure 5](#).

Table 25: Efficacy Results in Patients with CLL/SLL in iLLUMINATE

Endpoint	IMBRUVICA + Obinutuzumab N=113	Chlorambucil + Obinutuzumab N=116
Progression Free Survival^a		
Number of events (%)	24 (21)	74 (64)
Disease progression	11	64
Death events	13	10
Median (95% CI), months	NE	19.0 (15.1, 22.1)
HR (95% CI)	0.23 (0.15, 0.37)	
P-value ^b	<0.0001	
Overall Response Rate (%)^a	88.5	73.3
CR ^c (%)	19.5	7.8
PR ^d (%)	69.0	65.5

^a IRC-evaluated

^b P-value is from unstratified log-rank test

^c Includes 1 patient in the IMBRUVICA + obinutuzumab arm with a complete response with incomplete marrow recovery (CRi)

^d PR = nPR +PR

HR = hazard ratio; NE = not evaluable

Figure 5: Kaplan-Meier Curve of Progression-Free Survival (ITT Population) in Patients with CLL/SLL in iLLUMINATE

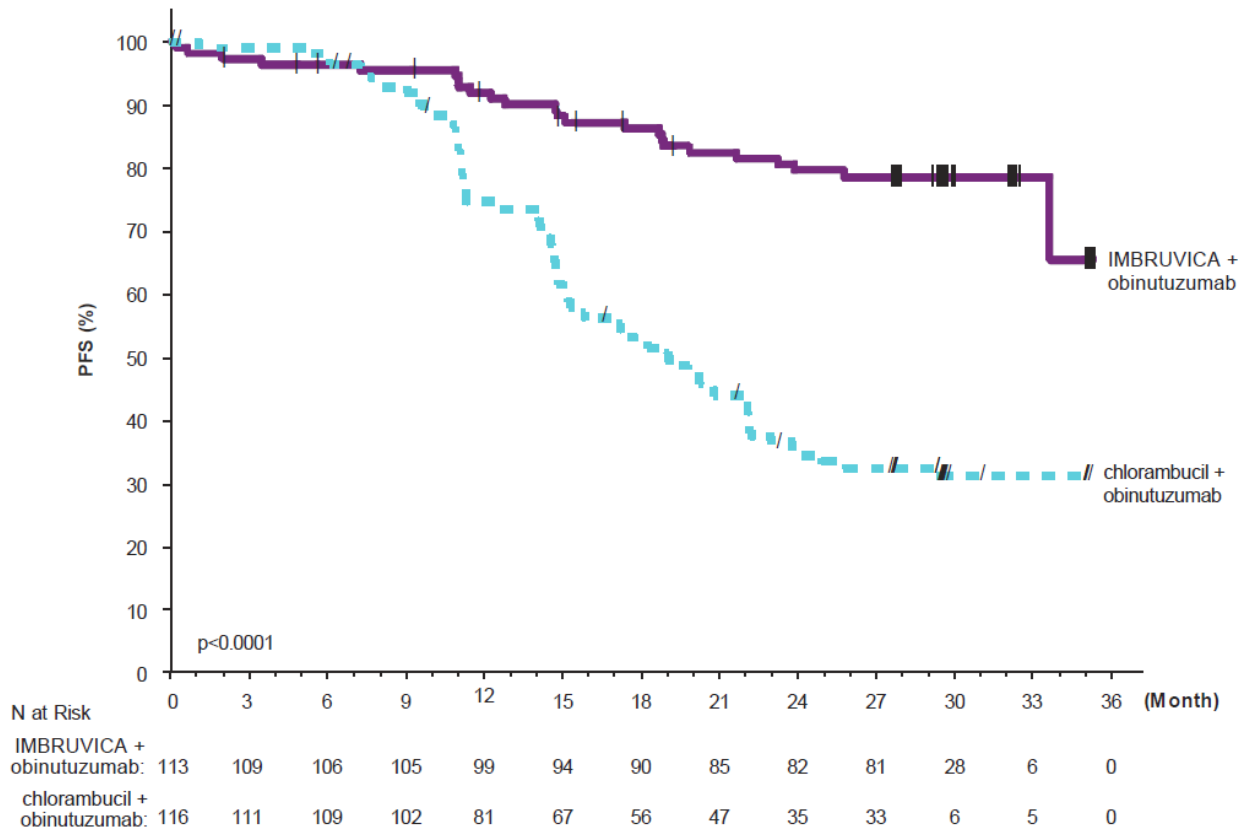

In the high risk CLL/SLL population (del 17p/TP53 mutation, del 11q, or unmutated IGHV), the PFS HR was 0.15 [95% CI (0.09, 0.27)].

E1912

The E1912 study (A Randomized Phase III Study of Ibrutinib based Therapy vs Standard Fludarabine, Cyclophosphamide, and Rituximab [FCR] Chemoimmunotherapy in Untreated Younger Patients with Chronic Lymphocytic Leukemia [CLL]) (NCT02048813) was conducted in adult patients who were 70 years or younger with previously untreated CLL or SLL requiring systemic therapy. All patients had a CLcr > 40 mL/min at baseline. Patients with 17p deletion were excluded. Patients (n=529) were randomized 2:1 to receive either IMBRUVICA plus rituximab (R) or FCR. IMBRUVICA was administered at 420 mg daily until disease progression or unacceptable toxicity. Fludarabine was administered at a dose of 25 mg/m², and cyclophosphamide was administered at a dose of 250 mg/m², both on Days 1, 2, and 3 of Cycles 1-6. Rituximab was initiated in Cycle 2 for the IMBRUVICA + R arm and in Cycle 1 for the FCR arm and was administered at 50 mg/m² on Day 1 of the first cycle, 325 mg/m² on Day 2 of the first cycle, and 500 mg/m² on Day 1 of 5 subsequent cycles, for a total of 6 cycles. Each cycle was 28 days.

The median age was 58 years (range, 28 to 70 years), 67% were male, 90% were White and 98% had a ECOG performance status of 0-1. At baseline, 43% of patients were Rai stage 3 or 4 and

59% of patients presented with high risk factors (TP53 mutation [6%], del11q [22%], or unmutated IGHV [53%]).

With a median follow-up time on study of 37 months, efficacy results for E1912 are shown in Table 26. The Kaplan-Meier curves for PFS, assessed according to IWCLL criteria is shown in Figure 6.

Table 26: Efficacy Results in Patients with CLL/SLL in E1912

Endpoint	IMBRUVICA + R N=354	FCR N=175
Progression Free Survival		
Number of events (%)	41 (12)	44 (25)
Disease progression	39	38
Death events	2	6
Median (95% CI), months	NE (49.4, NE)	NE (47.1, NE)
HR (95% CI)	0.34 (0.22, 0.52)	
P-value ^a	<0.0001	

^a P-value is from unstratified log-rank test.

FCR = fludarabine, cyclophosphamide, and rituximab; HR = hazard ratio; R = rituximab; NE = not evaluable

Figure 6: Kaplan-Meier Curve of Progression-Free Survival (ITT Population) in Patients with CLL/SLL in E1912

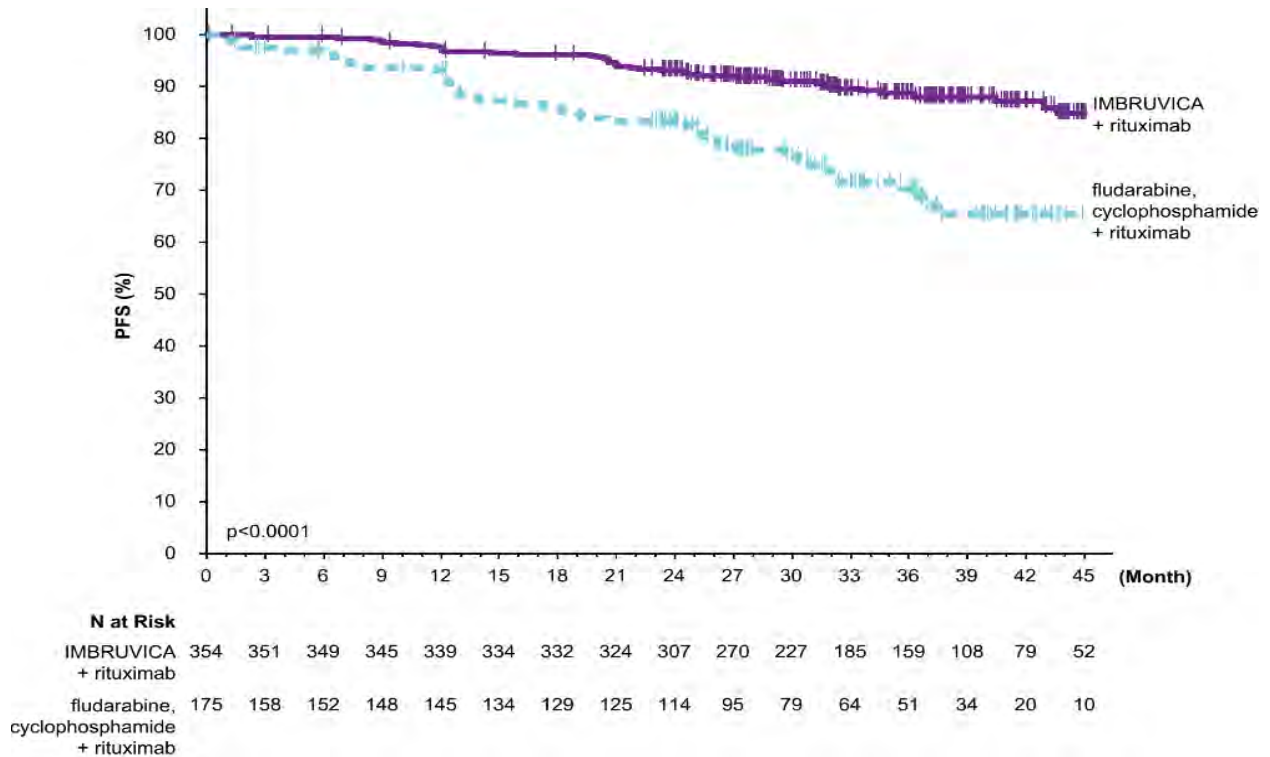

With a median follow-up time on study of 49 months, median overall survival was not reached with a total of 23 deaths: 11 (3%) in the IMBRUVICA plus rituximab and 12 (7%) in the FCR treatment arms.

Lymphocytosis

Upon initiation of single-agent IMBRUVICA, an increase in lymphocyte counts (i.e., $\geq 50\%$ increase from baseline and above absolute lymphocyte count of 5,000/mcL) occurred in 66% of patients in the CLL studies. The onset of isolated lymphocytosis occurs during the first month of IMBRUVICA therapy and resolves by a median of 14 weeks (range, 0.1 to 104 weeks). When IMBRUVICA was administered in combination, lymphocytosis was 7% with IMBRUVICA + BR versus 6% with placebo + BR and 7% with IMBRUVICA + obinutuzumab versus 1% with chlorambucil + obinutuzumab.

14.3 Waldenström’s Macroglobulinemia

The safety and efficacy of IMBRUVICA in patients with WM were demonstrated in two single-arm trials and one randomized, controlled trial.

Study 1118 and INNOVATE Monotherapy Arm

The safety and efficacy of IMBRUVICA in WM were evaluated in Study PCYC-1118E (referred to as Study 1118) (NCT01614821), an open-label, multi-center, single-arm trial of 63 previously treated patients. The median age was 63 years (range, 44 to 86 years), 76% were male, and 95% were White. All patients had a baseline ECOG performance status of 0 or 1. The median time since diagnosis was 74 months, and the median number of prior treatments was 2 (range, 1 to 11 treatments). At baseline, the median serum IgM value was 3.5 g/dL (range, 0.7 to 8.4 g/dL).

IMBRUVICA was administered orally at 420 mg once daily until disease progression or unacceptable toxicity. The responses were assessed by investigators and an IRC using criteria adopted from the International Workshop of Waldenström’s Macroglobulinemia. Responses, defined as partial response or better, per IRC are shown in [Table 27](#).

Table 27: Response Rate and Duration of Response (DOR) Based on IRC Assessment in Patients with WM in Study 1118

	Total (N=63)
Response rate (CR+VGPR+PR), (%)	61.9
95% CI (%)	(48.8, 73.9)
Complete Response (CR)	0
Very Good Partial Response (VGPR), (%)	11.1
Partial Response (PR), (%)	50.8
Median duration of response, months (range)	NE (2.8+, 18.8+)

CI = confidence interval; NE = not evaluable

The median time to response was 1.2 months (range, 0.7-13.4 months).

The INNOVATE monotherapy arm included 31 patients with previously treated WM who failed prior rituximab-containing therapy and received single-agent IMBRUVICA. The median age was 67 years (range, 47 to 90 years). Eighty-one percent of patients had a baseline ECOG performance status of 0 or 1, and 19% had a baseline ECOG performance status of 2. The median number of prior treatments was 4 (range, 1 to 7 treatments). The response rate observed in the INNOVATE monotherapy arm was 71% (0% CR, 29% VGPR, 42% PR). With a median follow-up time on study of 34 months (range, 8.6+ to 37.7 months), the median duration of response has not been reached.

INNOVATE

The INNOVATE study (A Randomized, Double-Blind, Placebo-Controlled, Phase 3 Study of Ibrutinib or Placebo in Combination with Rituximab in Subjects with Waldenström's Macroglobulinemia) (NCT02165397) was conducted in treatment naïve or previously treated patients with WM. Patients (n = 150) were randomized 1:1 to receive either IMBRUVICA 420 mg daily or placebo in combination with rituximab until disease progression or unacceptable toxicity. Rituximab was administered weekly at a dose of 375 mg/m² for 4 consecutive weeks (weeks 1-4) followed by a second course of weekly rituximab for 4 consecutive weeks (weeks 17-20). The major efficacy outcome measure is progression-free survival (PFS) assessed by an IRC with additional efficacy measure of response rate.

The median age was 69 years (range, 36 to 89 years), 66% were male, and 79% were White. Ninety-three percent of patients had a baseline ECOG performance status of 0 or 1, and 7% of patients had a baseline ECOG performance status of 2. Forty-five percent of patients were treatment naïve, and 55% of patients were previously treated. Among previously treated patients, the median number of prior treatments was 2 (range, 1 to 6 treatments). At baseline, the median serum IgM value was 3.2 g/dL (range, 0.6 to 8.3 g/dL), and MYD88 L265P mutations were present in 77% of patients, absent in 13% of patients, and 9% of patients were not evaluable for mutation status.

Efficacy results for INNOVATE as assessed by an IRC are shown in [Table 28](#), and the Kaplan-Meier curves for PFS are shown in [Figure 7](#).

Table 28: Efficacy Results in Patients with WM in INNOVATE

Endpoint	IMBRUVICA + R N=75	Placebo + R N=75
Progression Free Survival		
Number of events (%)	14 (19)	42 (56)
Median (95% CI), months	NE	20.3 (13.7, 27.6)
HR (95% CI)	0.20 (0.11, 0.38)	
P-value ^a	<0.0001	
Response Rate (CR+VGPR+PR)^b		
95% CI	72% (0.62, 0.82)	32% (0.21, 0.43)
Complete Response (CR)	3%	1%

Very Good Partial Response (VGPR)	23%	4%
Partial Response (PR)	47%	27%
Median duration of response, months (range)	NE (1.9+, 36.4+)	21.2 (4.6, 25.8)

CI = confidence interval; HR = hazard ratio; NE = not evaluable; R = rituximab

^a P-value is from log-rank test stratified by WM IPSS (low, med, high) and number of prior systemic treatment regimens (0, ≥ 1)

^b P-value associated with response rate was <0.0001 .

Median follow-up time on study = 26.5 months

Figure 7: Kaplan-Meier Curve of Progression-Free Survival (ITT Population) in Patients with WM in INNOVATE

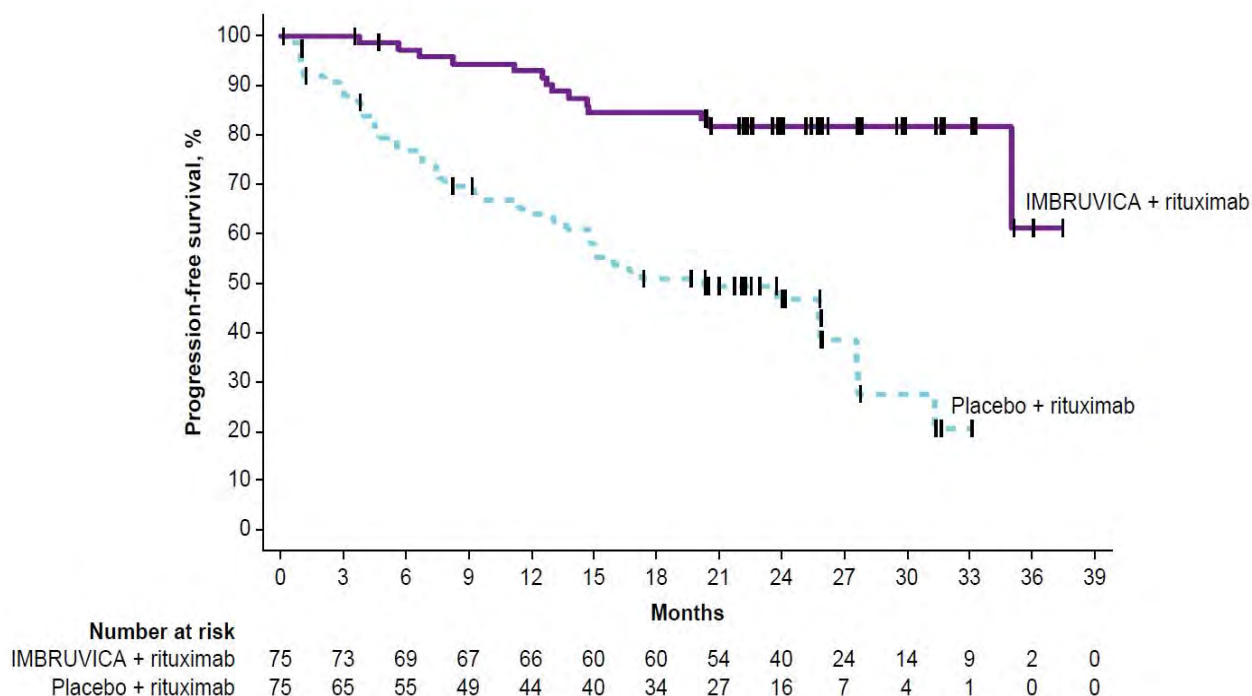

An exploratory analysis demonstrated a sustained hemoglobin improvement (defined as increase of ≥ 2 g/dL over baseline for at least 8 weeks without blood transfusions or growth factor support) in 65% of patients in the IMBRUVICA + R group and 39% of patients in the placebo + R group.

14.4 Marginal Zone Lymphoma

The safety and efficacy of IMBRUVICA in MZL were evaluated in Study PCYC-1121-CA (referred to as Study 1121) (NCT01980628), an open-label, multi-center, single-arm trial of patients who received at least one prior therapy. The efficacy analysis included 63 patients with 3 sub-types of MZL: mucosa-associated lymphoid tissue (MALT; N=32), nodal (N=17), and splenic (N=14). The median age was 66 years (range, 30 to 92 years), 59% were female, and 84% were White. Ninety two percent of patients had a baseline ECOG performance status of 0 or

1 and 8% had ECOG performance status 2. The median time since diagnosis was 3.8 years, and the median number of prior treatments was 2 (range, 1 to 9 treatments).

IMBRUVICA was administered orally at 560 mg once daily until disease progression or unacceptable toxicity. The responses were assessed by investigators and an IRC using criteria adopted from the International Working Group criteria for malignant lymphoma. Responses per IRC are shown in Table 29.

Table 29: Overall Response Rate (ORR) and Duration of Response (DOR) Based on IRC Assessment in Patients with MZL in Study 1121

	Total (N=63)
Response rate (CR + PR), (%)	46.0%
95% CI (%)	(33.4, 59.1)
Complete Response (CR), (%)	3.2
Partial Response (PR), (%)	42.9
Median duration of response, months (range)	NE (16.7, NE)

CI = confidence interval; NE = not evaluable
Median follow-up time on study = 19.4 months

The median time to response was 4.5 months (range, 2.3 to 16.4 months). Overall response rates were 46.9%, 41.2%, and 50.0% for the 3 MZL sub-types (MALT, nodal, splenic), respectively.

14.5 Chronic Graft versus Host Disease

The safety and efficacy of IMBRUVICA in cGVHD were evaluated in Study PCYC-1129-CA (referred to as Study 1129) (NCT02195869), an open-label, multi-center, single-arm trial of 42 patients with cGVHD after failure of first line corticosteroid therapy and requiring additional therapy.

The median age was 56 years (range, 19 to 74 years), 52% were male, and 93% were White. The most common underlying malignancies leading to transplantation were acute lymphocytic leukemia, acute myeloid leukemia, and CLL. The median time since cGVHD diagnosis was 14 months, the median number of prior cGVHD treatments was 2 (range, 1 to 3 treatments), and 60% of patients had a Karnofsky performance score of ≤ 80 . The majority of patients (88 %) had at least 2 organs involved at baseline, with the most commonly involved organs being mouth (86%), skin (81%), and gastrointestinal tract (33%). The median daily corticosteroid dose (prednisone or prednisone equivalent) at baseline was 0.3 mg/kg/day, and 52% of patients were receiving ongoing immunosuppressants in addition to systemic corticosteroids at baseline. Prophylaxis for infections were managed per institutional guidelines with 79% of patients receiving combinations of sulfonamides and trimethoprim and 64% receiving triazole derivatives.

IMBRUVICA was administered orally at 420 mg once daily. The responses were assessed by investigators using the 2005 National Institute of Health (NIH) Consensus Panel Response

Criteria with two modifications to align with the updated 2014 NIH Consensus Panel Response Criteria. Efficacy results are shown in Table 30.

Table 30: Best Overall Response Rate (ORR) and Sustained Response Rate Based on Investigator Assessment^a in Patients with cGVHD in Study 1129

	Total (N=42)
ORR	28 (67%)
95% CI	(51%, 80%)
Complete Response (CR)	9 (21%)
Partial Response (PR)	19 (45%)
Sustained response rate ^b	20 (48%)

CI = confidence interval

^a Investigator assessment based on the 2005 NIH Response Criteria with two modifications (added “not evaluable” for organs with non-cGVHD abnormalities, and organ score change from 0 to 1 was not considered disease progression)

^b Sustained response rate is defined as the proportion of patients who achieved a CR or PR that was sustained for at least 20 weeks.

The median time to response coinciding with the first scheduled response assessment was 12.3 weeks (range, 4.1 to 42.1 weeks). Responses were seen across all organs involved for cGVHD (skin, mouth, gastrointestinal tract, and liver).

ORR results were supported by exploratory analyses of patient-reported symptom bother which showed at least a 7-point decrease in Lee Symptom Scale overall summary score in 24% (10/42) of patients on at least 2 consecutive visits.

16 HOW SUPPLIED/STORAGE AND HANDLING

Capsules

The 70 mg capsules are supplied as yellow opaque capsules, marked with “ibr 70 mg” in black ink, in white HDPE bottles with a child-resistant closure:

- 28 capsules per bottle: NDC 57962-070-28

The 140 mg capsules are supplied as white opaque capsules, marked with “ibr 140 mg” in black ink, in white HDPE bottles with a child-resistant closure:

- 90 capsules per bottle: NDC 57962-140-09
- 120 capsules per bottle: NDC 57962-140-12

Store bottles at room temperature 20°C to 25°C (68°F to 77°F). Excursions are permitted between 15°C and 30°C (59°F to 86°F). Retain in original package until dispensing.

Tablets

The IMBRUVICA (ibrutinib) tablets are supplied in 4 strengths in the following packaging configurations:

- 140 mg tablets: Yellow green to green round tablets debossed with “ibr” on one side and “140” on the other side. Carton of one folded blister card containing two 14-count blister strips for a total of 28 tablets: NDC 57962-014-28
- 280 mg tablets: Purple oblong tablets debossed with “ibr” on one side and “280” on the other side. Carton of one folded blister card containing two 14-count blister strips for a total of 28 tablets: NDC 57962-280-28
- 420 mg tablets: Yellow green to green oblong tablets debossed with “ibr” on one side and “420” on the other side. Carton of one folded blister card containing two 14-count blister strips for a total of 28 tablets: NDC 57962-420-28
- 560 mg tablets: Yellow to orange oblong tablets debossed with “ibr” on one side and “560” on the other side. Carton of one folded blister card containing two 14-count blister strips for a total of 28 tablets: NDC 57962-560-28

Store tablets in original packaging at room temperature 20°C to 25°C (68°F to 77°F). Excursions are permitted between 15°C and 30°C (59°F to 86°F).

17 PATIENT COUNSELING INFORMATION

Advise the patient to read the FDA-approved patient labeling (Patient Information).

- *Hemorrhage:*
Inform patients of the possibility of bleeding, and to report any signs or symptoms (severe headache, blood in stools or urine, prolonged or uncontrolled bleeding). Inform the patient that IMBRUVICA may need to be interrupted for medical or dental procedures [*see Warnings and Precautions (5.1)*].
- *Infections:*
Inform patients of the possibility of serious infection, and to report any signs or symptoms (fever, chills, weakness, confusion) suggestive of infection [*see Warnings and Precautions (5.2)*].
- *Cardiac arrhythmias:*
Counsel patients to report any signs of palpitations, lightheadedness, dizziness, fainting, shortness of breath, and chest discomfort [*see Warnings and Precautions (5.4)*].
- *Hypertension:*
Inform patients that high blood pressure has occurred in patients taking IMBRUVICA, which may require treatment with anti-hypertensive therapy [*see Warnings and Precautions (5.5)*].
- *Second primary malignancies:*
Inform patients that other malignancies have occurred in patients who have been treated with IMBRUVICA, including skin cancers and other carcinomas [*see Warnings and Precautions (5.6)*].
- *Tumor lysis syndrome:*
Inform patients of the potential risk of tumor lysis syndrome and to report any signs and

symptoms associated with this event to their healthcare provider for evaluation [see *Warnings and Precautions (5.7)*].

- *Embryo-fetal toxicity:*

Advise women of the potential risk to a fetus. Advise females of reproductive potential to inform their healthcare provider of a known or suspected pregnancy [see *Warnings and Precautions (5.8)*, *Use in Specific Populations (8.1)*].

Advise females of reproductive potential to use effective contraception during treatment with IMBRUVICA and for 1 month after the last dose [see *Use in Specific Populations (8.3)*].

Advise males with female partners of reproductive potential to use effective contraception during treatment with IMBRUVICA and for 1 month after the last dose [see *Use in Specific Populations (8.3)*, *Nonclinical Toxicology (13.1)*].

- *Lactation:*

Advise women not to breastfeed during treatment with IMBRUVICA and for 1 week after the last dose [see *Use in Specific Populations (8.2)*].

- Inform patients to take IMBRUVICA orally once daily according to their physician's instructions and that the oral dosage (capsules or tablets) should be swallowed whole with a glass of water without opening, breaking or chewing the capsules or cutting, crushing or chewing the tablets approximately the same time each day [see *Dosage and Administration (2.1)*].
- Advise patients that in the event of a missed daily dose of IMBRUVICA, it should be taken as soon as possible on the same day with a return to the normal schedule the following day. Patients should not take extra doses to make up the missed dose [see *Dosage and Administration (2.1)*].
- Advise patients of the common side effects associated with IMBRUVICA [see *Adverse Reactions (6)*]. Direct the patient to a complete list of adverse drug reactions in PATIENT INFORMATION.
- Advise patients to inform their health care providers of all concomitant medications, including prescription medicines, over-the-counter drugs, vitamins, and herbal products [see *Drug Interactions (7)*].
- Advise patients that they may experience loose stools or diarrhea and should contact their doctor if their diarrhea persists. Advise patients to maintain adequate hydration [see *Adverse Reactions (6.1)*].

Active ingredient made in China.

Distributed and Marketed by:

Pharmacyclics LLC

Sunnyvale, CA USA 94085

and

Marketed by:

Janssen Biotech, Inc.

Horsham, PA USA 19044

Patent *<http://www.imbruvica.com>*

IMBRUVICA[®] is a registered trademark owned by Pharmacyclics LLC

© Pharmacyclics LLC 2020

© Janssen Biotech, Inc. 2020

PATIENT INFORMATION	
IMBRUVICA (im-BRU-vih-kuh) (ibrutinib) capsules	IMBRUVICA (im-BRU-vih-kuh) (ibrutinib) tablets
<p>What is IMBRUVICA? IMBRUVICA is a prescription medicine used to treat adults with:</p> <ul style="list-style-type: none"> • Mantle cell lymphoma (MCL) who have received at least one prior treatment • Chronic lymphocytic leukemia (CLL)/Small lymphocytic lymphoma (SLL) • Chronic lymphocytic leukemia (CLL)/Small lymphocytic lymphoma (SLL) with 17p deletion • Waldenström’s macroglobulinemia (WM) • Marginal zone lymphoma (MZL) who require a medicine by mouth or injection (systemic therapy) and have received a certain type of prior treatment • Chronic graft versus host disease (cGVHD) after failure of 1 or more lines of systemic therapy <p>It is not known if IMBRUVICA is safe and effective in children.</p>	
<p>Before taking IMBRUVICA, tell your healthcare provider about all of your medical conditions, including if you:</p> <ul style="list-style-type: none"> • have had recent surgery or plan to have surgery. Your healthcare provider may stop IMBRUVICA for any planned medical, surgical, or dental procedure. • have bleeding problems • have or had heart rhythm problems, smoke, or have a medical condition that increases your risk of heart disease, such as high blood pressure, high cholesterol, or diabetes • have an infection • have liver problems • are pregnant or plan to become pregnant. IMBRUVICA can harm your unborn baby. If you are able to become pregnant, your healthcare provider will do a pregnancy test before starting treatment with IMBRUVICA. Tell your healthcare provider if you are pregnant or think you may be pregnant during treatment with IMBRUVICA. <ul style="list-style-type: none"> ○ Females who are able to become pregnant should use effective birth control (contraception) during treatment with IMBRUVICA and for 1 month after the last dose. ○ Males with female partners who are able to become pregnant should use effective birth control, such as condoms, during treatment with IMBRUVICA and for 1 month after the last dose. • are breastfeeding or plan to breastfeed. Do not breastfeed during treatment with IMBRUVICA and for 1 week after the last dose. <p>Tell your healthcare provider about all the medicines you take, including prescription and over-the-counter medicines, vitamins, and herbal supplements. Taking IMBRUVICA with certain other medicines may affect how IMBRUVICA works and can cause side effects.</p>	
<p>How should I take IMBRUVICA?</p> <ul style="list-style-type: none"> • Take IMBRUVICA exactly as your healthcare provider tells you to take it. • Take IMBRUVICA 1 time a day. • Swallow IMBRUVICA capsules or tablets whole with a glass of water. • Do not open, break, or chew IMBRUVICA capsules. • Do not cut, crush, or chew IMBRUVICA tablets. • Take IMBRUVICA at about the same time each day. • If you miss a dose of IMBRUVICA take it as soon as you remember on the same day. Take your next dose of IMBRUVICA at your regular time on the next day. Do not take extra doses of IMBRUVICA to make up for a missed dose. • If you take too much IMBRUVICA call your healthcare provider or go to the nearest hospital emergency room right away. 	
<p>What should I avoid while taking IMBRUVICA? You should not drink grapefruit juice, eat grapefruit, or eat Seville oranges (often used in marmalades) during treatment with IMBRUVICA. These products may increase the amount of IMBRUVICA in your blood.</p>	
<p>What are the possible side effects of IMBRUVICA? IMBRUVICA may cause serious side effects, including:</p> <ul style="list-style-type: none"> • Bleeding problems (hemorrhage) are common during treatment with IMBRUVICA, and can also be serious and may lead to death. Your risk of bleeding may increase if you are also taking a blood thinner medicine. Tell your healthcare provider if you have any signs of bleeding, including: <ul style="list-style-type: none"> ○ blood in your stools or black stools (looks like tar) ○ pink or brown urine ○ unexpected bleeding, or bleeding that is severe or that you cannot control ○ vomit blood or vomit looks like coffee grounds ○ cough up blood or blood clots ○ increased bruising ○ dizziness ○ weakness ○ confusion ○ change in your speech ○ headache that lasts a long time or severe headache 	

- **Infections** can happen during treatment with IMBRUVICA. These infections can be serious and may lead to death. Tell your healthcare provider right away if you have fever, chills, weakness, confusion, or other signs or symptoms of an infection during treatment with IMBRUVICA.
- **Decrease in blood cell counts.** Decreased blood counts (white blood cells, platelets, and red blood cells) are common with IMBRUVICA, but can also be severe. Your healthcare provider should do monthly blood tests to check your blood counts.
- **Heart rhythm problems (ventricular arrhythmias, atrial fibrillation and atrial flutter).** Serious heart rhythm problems and death have happened in people treated with IMBRUVICA, especially in people who have an increased risk for heart disease, have an infection, or who have had heart rhythm problems in the past. Tell your healthcare provider if you get any symptoms of heart rhythm problems, such as feeling as if your heart is beating fast and irregular, lightheadedness, dizziness, shortness of breath, chest discomfort, or you faint. If you develop any of these symptoms, your healthcare provider may do a test to check your heart (ECG) and may change your IMBRUVICA dose.
- **High blood pressure (hypertension).** New or worsening high blood pressure has happened in people treated with IMBRUVICA. Your healthcare provider may start you on blood pressure medicine or change current medicines to treat your blood pressure.
- **Second primary cancers.** New cancers have happened during treatment with IMBRUVICA, including cancers of the skin or other organs.
- **Tumor lysis syndrome (TLS).** TLS is caused by the fast breakdown of cancer cells. TLS can cause kidney failure and the need for dialysis treatment, abnormal heart rhythm, seizure, and sometimes death. Your healthcare provider may do blood tests to check you for TLS.

The most common side effects of IMBRUVICA in adults with B-cell malignancies (MCL, CLL/SLL, WM and MZL) include:

- diarrhea
- tiredness
- muscle and bone pain
- rash
- bruising

The most common side effects of IMBRUVICA in adults with cGVHD include:

- tiredness
- bruising
- diarrhea
- mouth sores (stomatitis)
- muscle spasms
- nausea
- pneumonia

Diarrhea is a common side effect in people who take IMBRUVICA. Drink plenty of fluids during treatment with IMBRUVICA to help reduce your risk of losing too much fluid (dehydration) due to diarrhea. Tell your healthcare provider if you have diarrhea that does not go away.

These are not all the possible side effects of IMBRUVICA.

Call your doctor for medical advice about side effects. You may report side effects to FDA at 1-800-FDA-1088.

How should I store IMBRUVICA?

- Store IMBRUVICA capsules and tablets at room temperature between 68°F to 77°F (20°C to 25°C).
- Keep IMBRUVICA capsules in the original container with the lid tightly closed.
- Keep IMBRUVICA tablets in the original carton.

Keep IMBRUVICA and all medicines out of the reach of children.

General information about the safe and effective use of IMBRUVICA.

Medicines are sometimes prescribed for purposes other than those listed in a Patient Information leaflet. Do not use IMBRUVICA for a condition for which it was not prescribed. Do not give IMBRUVICA to other people, even if they have the same symptoms that you have. It may harm them. You can ask your pharmacist or healthcare provider for information about IMBRUVICA that is written for health professionals.

What are the ingredients in IMBRUVICA?

Active ingredient: ibrutinib

Inactive ingredients:

IMBRUVICA capsules: croscarmellose sodium, magnesium stearate, microcrystalline cellulose, and sodium lauryl sulfate. The 70 mg capsule shell contains gelatin, titanium dioxide, yellow iron oxide, and black ink. The 140 mg capsule shell contains gelatin, titanium dioxide, and black ink.

IMBRUVICA tablets: colloidal silicon dioxide, croscarmellose sodium, lactose monohydrate, magnesium stearate, microcrystalline cellulose, povidone, and sodium lauryl sulfate. The film coating for each tablet contains ferrousferic oxide (140 mg, 280 mg, and 420 mg tablets), polyvinyl alcohol, polyethylene glycol, red iron oxide (280 mg and 560 mg tablets), talc, titanium dioxide, and yellow iron oxide (140 mg, 420 mg, and 560 mg tablets).

Distributed and Marketed by: Pharmacyclics LLC Sunnyvale, CA USA 94085

Marketed by: Janssen Biotech, Inc. Horsham, PA USA 19044.

© Pharmacyclics LLC 2020

© Janssen Biotech, Inc. 2020

For more information, go to www.imbruvica.com or call 1-877-877-3536.

This Patient Information has been approved by the U.S. Food and Drug Administration.

Revised: 04/2020

PRODUCT MONOGRAPH

Pr **INVOKANA**[®]

canagliflozin tablets

100 mg and 300 mg as anhydrous canagliflozin

ATC Code: A10BK02

Other blood glucose lowering drugs, excl. insulins

Janssen Inc.
19 Green Belt Drive
Toronto, Ontario
M3C 1L9

Date of Revision:
May 20, 2020

www.janssen.com/canada

Submission Control No: 236246

All trademarks used under license.

© 2020 JANSSEN Inc.

TABLE OF CONTENTS

PART I: HEALTH PROFESSIONAL INFORMATION	3
SUMMARY PRODUCT INFORMATION	3
INDICATIONS AND CLINICAL USE.....	3
CONTRAINDICATIONS	4
WARNINGS AND PRECAUTIONS.....	5
ADVERSE REACTIONS.....	12
DRUG INTERACTIONS	33
DOSAGE AND ADMINISTRATION	36
OVERDOSAGE	38
ACTION AND CLINICAL PHARMACOLOGY	39
STORAGE AND STABILITY.....	44
SPECIAL HANDLING INSTRUCTIONS	44
DOSAGE FORMS, COMPOSITION AND PACKAGING	44
PART II: SCIENTIFIC INFORMATION	45
PHARMACEUTICAL INFORMATION.....	45
CLINICAL TRIALS.....	46
DETAILED PHARMACOLOGY	75
TOXICOLOGY	75
REFERENCES	78
PART III: PATIENT MEDICATION INFORMATION	79

PrINVOKANA®

canagliflozin tablets

100 mg and 300 mg as anhydrous canagliflozin

PART I: HEALTH PROFESSIONAL INFORMATION

SUMMARY PRODUCT INFORMATION

Route of Administration	Dosage Form / Strength	Clinically Relevant Nonmedicinal Ingredients
Oral	Tablets 100 mg and 300 mg	Lactose <i>For a complete listing see DOSAGE FORMS, COMPOSITION AND PACKAGING section.</i>

INDICATIONS AND CLINICAL USE

Monotherapy:

INVOKANA® (canagliflozin) is indicated as an adjunct to diet and exercise to improve glycemic control in adult patients with type 2 diabetes mellitus for whom metformin is inappropriate due to contraindications or intolerance.

Add-on combination:

INVOKANA® (canagliflozin) is indicated for use in adult patients with type 2 diabetes mellitus to improve glycemic control in combination with:

- metformin
- sulfonylurea (with or without metformin)
- pioglitazone with metformin
- metformin and sitagliptin
- insulin (with or without metformin)

when the therapy listed above, along with diet and exercise, does not provide adequate glycemic control (see **CLINICAL TRIALS**).

Add-On Combination in Patients with Established Cardiovascular Disease:

INVOKANA[®] is indicated as an adjunct to diet, exercise, and standard of care therapy to reduce the risk of major adverse cardiovascular events (cardiovascular death, nonfatal myocardial infarction and nonfatal stroke) in adults with type 2 diabetes mellitus and established cardiovascular disease (CVD).

Patients with Diabetic Nephropathy:

INVOKANA[®] is indicated as an adjunct to diet, exercise, and standard of care therapy to reduce the risk of end-stage kidney disease, doubling of serum creatinine, and cardiovascular (CV) death in adult patients with type 2 diabetes mellitus and diabetic nephropathy with albuminuria (>33.9 mg/mmol).

Geriatrics (≥65 years of age): Patients 65 years and older had a higher incidence of adverse reactions related to reduced intravascular volume with INVOKANA[®], including hypotension, postural dizziness, orthostatic hypotension, syncope, and dehydration. Reactions were more common in patients over 75 years of age and with the 300 mg daily (see **WARNINGS AND PRECAUTIONS, ADVERSE REACTIONS** and **DOSAGE AND ADMINISTRATION**). Smaller reductions in HbA1C with INVOKANA[®] relative to placebo were seen in patients 65 years and older, compared to younger patients (see **WARNINGS AND PRECAUTIONS, Special Populations**).

Pediatrics (<18 years of age): The safety and efficacy of INVOKANA[®] in pediatric patients under 18 years of age have not been established. Therefore, INVOKANA[®] should not be used in this population.

CONTRAINDICATIONS

- Patients who are hypersensitive to this drug or to any ingredient in the formulation or component of the container. For a complete listing, see **DOSAGE FORMS, COMPOSITION AND PACKAGING**.
- Patients on dialysis (see **DOSAGE and ADMINISTRATION**).

WARNINGS AND PRECAUTIONS

Serious Warnings and Precautions

Diabetic Ketoacidosis

- Clinical trial and post-market cases of diabetic ketoacidosis (DKA), a serious life-threatening condition requiring urgent hospitalization, have been reported in patients with type 2 diabetes mellitus (T2DM) treated with INVOKANA[®], or other sodium-glucose co-transporter 2 (SGLT2) inhibitors. Fatal cases of DKA have been reported in patients taking INVOKANA[®]. A number of these cases have been atypical with blood glucose values below 13.9 mmol/L (250 mg/dL) (see **ADVERSE REACTIONS**).
- The risk of DKA must be considered in the event of non-specific symptoms such as difficulty breathing, nausea, vomiting, abdominal pain, confusion, anorexia, excessive thirst and unusual fatigue or sleepiness. If these symptoms occur, regardless of blood glucose level, INVOKANA[®] treatment should be immediately **discontinued and patients should be assessed for DKA immediately**.
- INVOKANA[®] should not be used for the treatment of DKA or in patients with a history of DKA.
- Nephropathy may increase the risk of DKA during treatment with INVOKANA[®].
- INVOKANA[®] is not indicated, and should not be used, in patients with type 1 diabetes.
- See **WARNINGS AND PRECAUTIONS, Endocrine and Metabolism**.

Lower Limb Amputation

- An approximately 2-fold increased risk of lower limb amputations associated with INVOKANA[®] use was observed in CANVAS and CANVAS-R, two large, randomized, placebo-controlled trials in patients with type 2 diabetes who had established cardiovascular disease (CVD) or were at risk for CVD.
- Amputations of the toe and midfoot were most frequent; however, amputations involving the leg were also observed. Some patients had multiple amputations, some involving both limbs.
- Before initiating INVOKANA[®], consider factors that may increase the risk of amputation, such as a history of prior amputation, peripheral vascular disease, neuropathy, and diabetic foot ulcers.
- Monitor patients receiving INVOKANA[®] for infection, new pain or tenderness, sores or ulcers involving the lower limbs, and discontinue INVOKANA[®] if these complications occur.
- See **WARNINGS AND PRECAUTIONS, Cardiovascular**.

Cardiovascular

Lower limb amputation:

An approximately 2-fold-increased risk of lower limb amputations associated with INVOKANA[®] use was observed in CANVAS and CANVAS-R, two large, randomized, placebo-controlled trials evaluating patients with type 2 diabetes who had either established cardiovascular disease or were at risk for cardiovascular disease. In CANVAS, INVOKANA[®]-treated patients and placebo-treated patients had 5.9 and 2.8 amputations per 1000 patients per year, respectively. In CANVAS-R, INVOKANA[®]-treated patients and placebo-treated patients had 7.5 and 4.2 amputations per 1000 patients per year, respectively. The risk of lower limb amputations was observed at both the 100 mg and 300 mg once daily dosage regimens. The amputation data for CANVAS and CANVAS-R are shown in Tables 10 and 11, respectively (see **ADVERSE REACTIONS**).

Amputations of the toe and midfoot (99 out of 140 patients with amputations receiving INVOKANA[®] in the two trials) were the most frequent; however, amputations involving the leg, below and above the knee, were also observed (41 out of 140 patients with amputations receiving INVOKANA[®] in the two trials). Some patients had multiple amputations, some involving both lower limbs. Lower limb infections, gangrene, and diabetic foot ulcers were the most common precipitating medical events leading to the need for an amputation. The risk of amputation was highest in patients with a baseline history of prior amputation, peripheral vascular disease, and neuropathy.

Before initiating INVOKANA[®], consider factors in the patient history that may predispose to the need for amputations, such as a history of prior amputation, peripheral vascular disease, neuropathy and diabetic foot ulcers. Counsel patients about the importance of routine preventative foot care and adequate hydration. Monitor patients receiving INVOKANA[®] for signs and symptoms of infection (including osteomyelitis), new pain or tenderness, sores or ulcers involving the lower limbs, and discontinue INVOKANA[®] if these complications occur.

Reduced Intravascular Volume:

Due to its mechanism of action, INVOKANA[®] increases urinary glucose excretion (UGE) and induces an osmotic diuresis, which may reduce intravascular volume.

Patients most susceptible to adverse reactions related to reduced intravascular volume (e.g., postural dizziness, orthostatic hypotension, hypotension or renal failure) include patients with moderate renal impairment, elderly patients, patients on loop diuretics or medications that interfere with the renin-angiotensin-aldosterone system (e.g., angiotensin-converting-enzyme [ACE] inhibitors, angiotensin receptor blockers [ARBs]), and patients with low systolic blood pressure (see **ADVERSE REACTIONS, DRUG INTERACTIONS** and **DOSAGE AND ADMINISTRATION**). Before initiating INVOKANA[®] in patients with one or more of these characteristics, volume status should be assessed and any volume depletion corrected. Caution should also be exercised in other patients for whom a drop in blood pressure could pose a risk, such as patients with known cardiovascular disease. Monitor for signs and symptoms after

initiating therapy. Patients should be advised to report symptoms of reduced intravascular volume.

In placebo-controlled clinical studies of INVOKANA[®], increases in adverse reactions related to reduced intravascular volume were seen more commonly with the 300 mg dose and occurred most frequently in the first three months (see **ADVERSE REACTIONS**).

INVOKANA[®] is not recommended for use in patients receiving loop diuretics (see **ADVERSE REACTIONS** and **DOSAGE AND ADMINISTRATION**) or who are volume depleted.

In case of intercurrent conditions that may lead to volume depletion (such as a gastrointestinal illness), careful monitoring of volume status (e.g., physical examination, blood pressure measurements, laboratory tests including renal function tests), and serum electrolytes is recommended. In the case of volume depletion, temporary interruption of treatment with canagliflozin may be considered until the condition is corrected, and more frequent glucose monitoring may be considered.

Endocrine and Metabolism

Diabetic ketoacidosis:

Clinical trial and post-market cases of DKA, a serious life-threatening condition requiring urgent hospitalization, have been reported in patients with type 2 diabetes mellitus treated with SGLT2 inhibitors, including INVOKANA[®]. Fatal cases of DKA have been reported in patients taking INVOKANA[®]. In a number of reported cases, the presentation of the condition was atypical with blood glucose values below 13.9 mmol/L (250 mg/dL) (see **ADVERSE REACTIONS**).

INVOKANA[®] is not indicated, and should not be used, in patients with type 1 diabetes. The diagnosis of T2DM should therefore be confirmed before initiating INVOKANA[®].

INVOKANA[®] should not be used for the treatment of DKA or in patients with a history of DKA.

Patients with type 2 diabetes treated with INVOKANA[®] who present with signs and symptoms consistent with severe metabolic acidosis should be assessed for ketoacidosis regardless of presenting blood glucose levels, as ketoacidosis associated with INVOKANA[®] may be present even if blood glucose levels are less than 13.9 mmol/L (250 mg/dL).

The risk of DKA must be considered in the event of non-specific symptoms such as difficulty breathing, nausea, vomiting, abdominal pain, confusion, anorexia, excessive thirst, unusual fatigue or sleepiness.

If these symptoms occur, regardless of blood glucose level, INVOKANA[®] treatment should be immediately discontinued, patients should be assessed for diabetic ketoacidosis immediately, and prompt treatment should be instituted.

SGLT2 inhibitors have been shown to increase blood ketones in clinical trial subjects. Conditions that can precipitate DKA while taking INVOKANA[®] include patients on a very low

carbohydrate diet (as the combination may further increase ketone body production), patients with conditions that lead to restricted food intake or severe dehydration, patients with increased insulin requirement due to an acute medical illness, surgery, or alcohol abuse, patients with a low beta-cell function reserve [e.g., type 2 diabetes patients with low C-peptide or latent autoimmune diabetes in adults (LADA)], pancreatic disorders suggesting insulin deficiency (e.g., type 1 diabetes, history of pancreatitis, or pancreatic surgery), insulin dose reduction (including insulin pump failure), and patients with a history of ketoacidosis. Patients with nephropathy may be more susceptible to DKA during treatment with SGLT2 inhibitors. Patients with these risk factors should be monitored closely. Caution should also be taken when reducing the insulin dose in patients requiring insulin (see **DOSAGE AND ADMINISTRATION**).

Temporarily discontinue treatment with INVOKANA[®] in T2DM patients who are hospitalized for major surgical procedures, or will undergo scheduled surgery, and patients who are hospitalized for serious infections or acute serious medical illnesses. Monitoring for DKA is recommended in these patients even if INVOKANA[®] treatment has been interrupted or discontinued. Ensure risk factors for ketoacidosis are resolved prior to restarting INVOKANA[®].

Educate patients on the signs and symptoms of ketoacidosis and instruct patients to discontinue INVOKANA[®] and seek medical attention immediately if signs and symptoms occur.

Hypoglycemia in Add-on Therapy with other Antihyperglycemic Agents:

When INVOKANA[®] was used as add-on therapy with insulin or an insulin secretagogue (e.g., sulfonylurea), the incidence of hypoglycemia was increased over that of placebo. Therefore, to lower the risk of hypoglycemia, a dose reduction of insulin or an insulin secretagogue may be considered (see **ADVERSE REACTIONS** and **DOSAGE AND ADMINISTRATION**).

Increases in Low-Density Lipoprotein (LDL-C): Dose-related increases in LDL-C are seen with INVOKANA[®] treatment (see **ADVERSE REACTIONS**). LDL-C levels should be monitored.

Genitourinary

Genital Mycotic Infections:

INVOKANA[®] increases the risk of genital mycotic infections, consistent with the mechanism of increased urinary glucose excretion. Patients with a history of genital mycotic infections and uncircumcised males were more likely to develop genital mycotic infections (see **ADVERSE REACTIONS**).

Urinary tract infections (including urosepsis and pyelonephritis):

Treatment with INVOKANA[®] increases the risk for urinary tract infections (see **ADVERSE REACTIONS**). There have been post-marketing reports of serious urinary tract infections, including urosepsis and pyelonephritis, requiring hospitalization in patients treated with INVOKANA[®].

Fournier’s gangrene (necrotizing fasciitis of the perineum):

Post-marketing cases of necrotizing fasciitis of the perineum (Fournier’s gangrene), a rare but serious and potentially life threatening necrotizing infection requiring urgent surgical intervention, have been reported in female and male patients with diabetes mellitus receiving SGLT2 inhibitors, including INVOKANA[®]. Serious outcomes have included hospitalization, multiple surgeries and death.

Patients treated with INVOKANA[®] who present with pain or tenderness, erythema, or swelling in the genital or perineal area, with or without fever, or malaise should be evaluated for necrotizing fasciitis. If suspected, INVOKANA[®] should be discontinued and prompt treatment should be instituted (including broad-spectrum antibiotics and surgical debridement if necessary).

Hematologic

Elevated Hemoglobin and Hematocrit: Mean hemoglobin and hematocrit increased in patients administered INVOKANA[®], as did the frequency of patients with abnormally elevated values for hemoglobin/hematocrit (see **ADVERSE REACTIONS**). INVOKANA[®] should be used with caution in patients with an elevated hematocrit.

Immune

Hypersensitivity: Serious hypersensitivity reactions, including angioedema and anaphylaxis, have been reported post-market in patients treated with canagliflozin. If a hypersensitivity reaction is suspected, discontinue INVOKANA[®], assess for other potential causes and initiate alternative treatment for diabetes (see **ADVERSE REACTIONS**, **Post-Market Adverse Drug Reactions**).

Musculoskeletal

Bone fractures: An increased risk of bone fractures, occurring as early as 12 weeks after treatment initiation, was observed in patients using INVOKANA[®]. Consider factors that contribute to fracture risk prior to initiating INVOKANA[®].

Renal**Impairment of renal function:**

INVOKANA[®] increases serum creatinine and decreases eGFR in a dose dependent fashion. In clinical trials, renal function abnormalities have occurred after initiating INVOKANA[®]. Post-marketing cases of acute kidney injury, including acute renal failure and a decline in eGFR, some requiring hospitalization and dialysis, have been reported in patients receiving SGLT2 inhibitors, including INVOKANA[®]. Before initiating INVOKANA[®], consider factors that may predispose patients to acute kidney injury including hypovolemia, chronic renal insufficiency, congestive heart failure and concomitant medications (diuretics, ACE inhibitors, ARBs, NSAIDs). Consider temporarily discontinuing INVOKANA[®] in any setting of reduced oral intake (such as acute illness or fasting) or fluid losses (such as gastrointestinal illness or

excessive heat exposure); monitor patients for signs and symptoms of acute kidney injury. If acute kidney injury occurs, discontinue INVOKANA[®] promptly and institute treatment (see **WARNINGS AND PRECAUTIONS, Cardiovascular** and **ADVERSE REACTIONS**).

Renal function should be assessed prior to initiation of INVOKANA[®] and regularly thereafter. In patients with eGFR less than 60 mL/min/1.73m², more intensive monitoring for glycemic and renal biomarkers and signs and symptoms of renal dysfunction is recommended especially if the eGFR is less than 45 mL/min/1.73m².

The glucose-lowering benefit of INVOKANA[®] decreases with declining renal function and has not been demonstrated for patients with eGFR <30 mL/min/1.73 m².

In patients with type 2 diabetes already initiated on treatment for diabetic nephropathy, the use of INVOKANA[®] 100 mg can be continued in patients with an eGFR <30 mL/min/1.73 m². INVOKANA[®] 100 mg should be discontinued if dialysis is initiated (see **CONTRAINDICATIONS** and **DOSAGE AND ADMINISTRATION**).

Special Populations

Pregnant Women: INVOKANA[®] should not be used during pregnancy. There are no adequate and well-controlled studies in pregnant women. Based on results from rat studies, canagliflozin may affect renal development and maturation. In a juvenile rat study, increased kidney weights and renal pelvic and tubular dilatation were evident at greater than or equal to 0.5 times clinical exposure from a 300 mg dose (see **TOXICOLOGY**).

Nursing Women: INVOKANA[®] should not be used during nursing because of the potential for serious adverse reactions in nursing infants. It is not known if canagliflozin is excreted in human milk. Available pharmacodynamic/toxicological data in animals have shown excretion of canagliflozin in the milk of lactating rats reaching levels which are approximately 1.4 times higher than plasma systemic exposure. Data in juvenile rats directly exposed to INVOKANA[®] showed risk to the developing kidney (renal pelvic and tubular dilatations) during maturation.

Pediatrics (<18 years of age): Safety and effectiveness of INVOKANA[®] in pediatric patients under 18 years of age have not been established. Therefore, INVOKANA[®] should not be used in this population.

Geriatrics (≥65 years of age): Two thousand thirty-four (2,034) patients 65 years and older, and 345 patients 75 years and older were exposed to INVOKANA[®] in nine clinical studies of INVOKANA[®] (see **CLINICAL TRIALS**).

Patients 65 years and older had a higher incidence of adverse reactions related to reduced intravascular volume with INVOKANA[®] (such as hypotension, postural dizziness, orthostatic hypotension, syncope, and dehydration), particularly with the 300 mg daily dose, compared to younger patients; more prominent increase in the incidence was seen in patients who were 75 years and older (see **DOSAGE AND ADMINISTRATION** and **ADVERSE REACTIONS**). Smaller reductions in HbA1C with INVOKANA[®] relative to placebo were seen in older patients

(65 years and older; -0.61% with INVOKANA[®] 100 mg and -0.74% with INVOKANA[®] 300 mg relative to placebo) compared to younger patients (-0.72% with INVOKANA[®] 100 mg and -0.87% with INVOKANA[®] 300 mg relative to placebo).

Hepatic Impairment: INVOKANA[®] has not been studied in patients with severe hepatic impairment and is therefore not recommended for use in this patient population. No dose adjustment is necessary in patients with mild or moderate hepatic impairment.

Monitoring and Laboratory Tests

Blood Glucose and Hb_{A1c}: Response to INVOKANA[®] treatment should be monitored by periodic measurements of blood glucose and Hb_{A1c} levels. Due to its mechanism of action, patients taking INVOKANA[®] will test positive for glucose in their urine.

Renal function: Renal function should be assessed prior to initiation of INVOKANA[®] and regularly thereafter, with more frequent renal function monitoring in patients whose eGFR is <60 mL/min/1.73 m². Monitoring of renal function is recommended prior to and following initiation of any concomitant drug which might have an impact on renal function.

Reduced intravascular volume: INVOKANA[®] is not recommended for use in patients who are volume depleted. Before initiating INVOKANA[®], assess volume status, particularly in patients at risk (e.g., moderate renal impairment, the elderly, in patients with low systolic blood pressure, or if on a loop diuretic, angiotensin-converting enzyme inhibitor, or angiotensin receptor blocker).

In patients with volume depletion, the condition should be corrected prior to initiation of INVOKANA[®] (see **DOSAGE AND ADMINISTRATION**).

For patients with risk factors for volume depletion or in case of intercurrent conditions that may lead to volume depletion (such as a gastrointestinal illness), careful monitoring of volume status (e.g., physical examination, blood pressure measurements, laboratory tests including renal function tests), and serum electrolytes is recommended during treatment with INVOKANA[®]. Temporary interruption of treatment with INVOKANA[®] should be considered until volume depletion is corrected.

LDL-cholesterol: LDL-C levels should be measured at baseline and at regular intervals during treatment with INVOKANA[®] due to dose-dependent increases in LDL-C seen with therapy.

Digoxin levels: In patients taking digoxin and INVOKANA[®] 300 mg once daily for seven days, there was an increase in the total exposure (AUC) and peak drug concentration (C_{max}) of digoxin (20% and 36%, respectively), therefore patients taking INVOKANA[®] concomitantly with digoxin should be monitored appropriately.

ADVERSE REACTIONS

Adverse Drug Reaction Overview

The safety of INVOKANA[®] (canagliflozin) was evaluated in fifteen double-blind, controlled Phase 3 and Phase 4 clinical studies involving 22,645 patients with type 2 diabetes, including 13,278 patients treated with INVOKANA[®] 100 mg and 7,170 patients, treated with INVOKANA[®] 300 mg. Of the 22,645 patients with type 2 diabetes, a total of 10,134 patients were treated in two dedicated cardiovascular outcomes studies for a mean exposure duration of 149 weeks (223 weeks in CANVAS and 94 weeks in CANVAS-R), and 8,114 patients were treated in 12 double-blind, controlled Phase 3 and Phase 4 clinical studies, for a mean exposure duration of 49 weeks. In a dedicated renal outcomes study, a total of 4,397 patients with type 2 diabetes and diabetic nephropathy had a mean duration of drug exposure of 115 weeks.

The primary assessment of safety and tolerability was conducted in a pooled analysis (N=2313) of four 26-week placebo-controlled clinical studies (monotherapy and add-on therapy with metformin, metformin and sulfonylurea, and metformin and pioglitazone). The most commonly reported adverse reactions during treatment ($\geq 5\%$) were vulvovaginal candidiasis, urinary tract infection (UTI), and polyuria or pollakiuria. Adverse reactions leading to discontinuation of $\geq 0.5\%$ of all INVOKANA[®]-treated patients in these studies were vulvovaginal candidiasis (0.7% of females) and balanitis or balanoposthitis (0.5% of males).

A total of 8 serious adverse drug reactions were reported in the primary placebo-controlled safety population, including 5 reports from patients taking INVOKANA[®] 100 mg daily (2 urticaria, 2 UTI, and 1 nausea), 2 reports from patients taking INVOKANA[®] 300 mg daily (1 UTI, 1 constipation) and 1 report from a patient in the placebo group (reduced intravascular volume). Of these serious adverse reactions, 2 led to discontinuation in the INVOKANA[®] group (UTI and urticaria).

Clinical Trial Adverse Drug Reactions

Because clinical trials are conducted under very specific conditions the adverse reaction rates observed in the clinical trials may not reflect the rates observed in practice and should not be compared to the rates in the clinical trials of another drug. Adverse drug reaction information from clinical trials is useful for identifying drug-related adverse events and for approximating rates.

Table 1 to Table 8 include treatment-emergent adverse events (TEAEs) reported in $\geq 2\%$ of INVOKANA[®]-treated patients.

Monotherapy (Study DIA3005)

The incidence of adverse events, reported regardless of causality in $\geq 2\%$ of patients treated with INVOKANA[®] 100 mg or 300 mg and more frequently than in the placebo group, is provided in Table 1. The core assessment period was 26 weeks for this placebo-controlled study.

Table 1: Adverse events (regardless of causality) reported in $\geq 2\%$ of patients treated with INVOKANA[®] and more frequently than in the placebo group in a double-blind clinical trial (Study DIA3005) of INVOKANA[®] compared with placebo

System Organ Class / Preferred Term	Placebo n=192 n (%)	INVOKANA[®] 100 mg n=195 n (%)	INVOKANA[®] 300 mg n=197 n (%)
Gastrointestinal Disorders			
Constipation	2 (1.0)	4 (2.1)	6 (3.0)
Nausea	3 (1.6)	5 (2.6)	4 (2.0)
General Disorders and Administration Site Conditions			
Thirst	1 (0.5)	3 (1.5)	6 (3.0)
Infections and Infestations			
Bronchitis	2 (1.0)	6 (3.1)	2 (1.0)
Gastroenteritis	3 (1.6)	2 (1.0)	4 (2.0)
Influenza	6 (3.1)	9 (4.6)	8 (4.1)
Nasopharyngitis	10 (5.2)	10 (5.1)	16 (8.1)
Pharyngitis	1 (0.5)	6 (3.1)	4 (2.0)
Urinary Tract Infection	8 (4.2)	14 (7.2)	9 (4.6)
Vulvovaginal Mycotic Infection	2 (1.0)	4 (2.1)	2 (1.0)
Investigations			
Blood Creatine Phosphokinase Increased	1 (0.5)	0	4 (2.0)
Musculoskeletal and Connective Tissue Disorders			
Back Pain	6 (3.1)	5 (2.6)	12 (6.1)
Musculoskeletal Pain	3 (1.6)	4 (2.1)	1 (0.5)
Nervous System Disorders			
Headache	7 (3.6)	14 (7.2)	12 (6.1)
Renal and Urinary Disorders			
Pollakiuria	1 (0.5)	5 (2.6)	6 (3.0)
Polyuria	0	0	6 (3.0)
Reproductive System and Breast Disorders			
Vulvovaginal Pruritus	0	1 (0.5)	4 (2.0)
Respiratory, Thoracic and Mediastinal Disorders			
Cough	2 (1.0)	3 (1.5)	4 (2.0)

Combination with Metformin (Studies DIA3006 and DIA3009)

The incidence of adverse events, reported regardless of causality in $\geq 2\%$ of patients treated with INVOKANA® 100 mg or 300 mg and more frequently than in the placebo groups, in studies of INVOKANA® as add-on combination therapy with metformin, is provided in Table 2. The core assessment period was 26 weeks for the placebo- and active-controlled study versus sitagliptin (DIA3006) and 52 weeks for the active-controlled study versus glimepiride (DIA3009).

Table 2: Adverse events (regardless of causality) reported in $\geq 2\%$ of patients treated with INVOKANA® and more frequently than in the placebo groups* in double-blind clinical trials of INVOKANA® in add-on combination use with metformin, and compared to sitagliptin or placebo (Study DIA3006) or to glimepiride (Study DIA3009)

System Organ Class / Preferred Term	Study DIA3006 (26 weeks)				Study DIA3009 (52 weeks)		
	Placebo + Metformin n=183 n (%)	INVOKANA® 100 mg + Metformin n=368 n (%)	INVOKANA® 300 mg + Metformin N=367 n (%)	Sitagliptin 100 mg + Metformin n=366 n (%)	INVOKANA® 100 mg + Metformin n=483 n (%)	INVOKANA® 300 mg + Metformin n=485 n (%)	Glimepiride + Metformin n=482 n (%)
Gastrointestinal Disorders							
Diarrhea	12 (6.6)	12 (3.3)	18 (4.9)	16 (4.4)	24 (5.0)	33 (6.8)	29 (6.0)
Gastritis	3 (1.6)	3 (0.8)	8 (2.2)	3 (0.8)	2 (0.4)	5 (1.0)	7 (1.5)
Nausea	3 (1.6)	11 (3.0)	8 (2.2)	5 (1.4)	16 (3.3)	25 (5.2)	13 (2.7)
Toothache	2 (1.1)	3 (0.8)	8 (2.2)	4 (1.1)	8 (1.7)	7 (1.4)	6 (1.2)
Vomiting	1 (0.5)	8 (2.2)	1 (0.3)	3 (0.8)	9 (1.9)	7 (1.4)	8 (1.7)
General Disorders and Administration Site Conditions							
Fatigue	2 (1.1)	10 (2.7)	8 (2.2)	1 (0.3)	9 (1.9)	7 (1.4)	10 (2.1)
Pyrexia	3 (1.6)	4 (1.1)	5 (1.4)	3 (0.8)	11 (2.3)	9 (1.9)	7 (1.5)
Thirst	0	2 (0.5)	4 (1.1)	0	8 (1.7)	14 (2.9)	0
Infections and Infestations							
Bronchitis	2 (1.1)	2 (0.5)	5 (1.4)	9 (2.5)	11 (2.3)	9 (1.9)	10 (2.1)
Gastroenteritis	2 (1.1)	3 (0.8)	3 (0.8)	2 (0.5)	3 (0.6)	15 (3.1)	9 (1.9)
Influenza	5 (2.7)	6 (1.6)	4 (1.1)	8 (2.2)	17 (3.5)	17 (3.5)	8 (1.7)
Sinusitis	3 (1.6)	8 (2.2)	2 (0.5)	6 (1.6)	7 (1.4)	13 (2.7)	6 (1.2)
Urinary Tract Infection	4 (2.2)	19 (5.2)	13 (3.5)	12 (3.3)	27 (5.6)	24 (4.9)	18 (3.7)
Vaginal Infection	0	2 (0.5)	3 (0.8)	1 (0.3)	11 (2.3)	7 (1.4)	1 (0.2)
Vulvovaginal Mycotic Infection	0	10 (2.7)	7 (1.9)	1 (0.3)	6 (1.2)	14 (2.9)	4 (0.8)
Musculoskeletal and Connective Tissue Disorders							
Back Pain	6 (3.3)	8 (2.2)	12 (3.3)	4 (1.1)	29 (6.0)	18 (3.7)	20 (4.1)
Musculoskeletal Pain	1 (0.5)	3 (0.8)	6 (1.6)	5 (1.4)	9 (1.9)	10 (2.1)	9 (1.9)
Psychiatric Disorders							
Insomnia	0	3 (0.8)	0	1 (0.3)	7 (1.4)	10 (2.1)	6 (1.2)
Renal and Urinary Disorders							
Pollakiuria	1 (0.5)	21 (5.7)	10 (2.7)	2 (0.5)	12 (2.5)	12 (2.5)	1 (0.2)
Reproductive System and Breast Disorders							
Balanoposthitis	1 (0.5)	2 (0.5)	1 (0.3)	0	4 (0.8)	13 (2.7)	2 (0.4)
Vulvovaginal Pruritus	0	4 (1.1)	5 (1.4)	1 (0.3)	6 (1.2)	20 (4.1)	1 (0.2)

*In either study

Combination with a Sulfonylurea (Study DIA3008 SU Substudy)

The incidence of adverse events, reported regardless of causality in $\geq 2\%$ of patients treated with INVOKANA[®] 100 mg or 300 mg and more frequently than in the placebo group, in a study of INVOKANA[®] as add-on combination therapy with a sulfonylurea, is shown in Table 3. The core assessment period was 18 weeks for this placebo-controlled study.

Table 3: Adverse events (regardless of causality) reported in $\geq 2\%$ of patients treated with INVOKANA[®] and more frequently than in the placebo group in a double-blind clinical trial of INVOKANA[®] in add-on combination use with a sulfonylurea, and compared to placebo (Study DIA3008 - sulfonylurea substudy)

System Organ Class / Preferred Term	Placebo + Sulfonylurea n=69 n (%)	INVOKANA[®] 100 mg + Sulfonylurea n=74 n (%)	INVOKANA[®] 300 mg + Sulfonylurea n=72 n (%)
Gastrointestinal Disorders			
Diarrhea	1 (1.4)	0	2 (2.8)
General Disorders and Administration Site Conditions			
Chest Pain	0	2 (2.7)	1 (1.4)
Thirst	0	1 (1.4)	2 (2.8)
Infections and Infestations			
Herpes Zoster	0	0	2 (2.8)
Vulvovaginal Candidiasis	0	2 (2.7)	0
Investigations			
Blood Creatinine Increased	1 (1.4)	2 (2.7)	1 (1.4)
Nervous System Disorders			
Dizziness	0	2 (2.7)	0
Headache	1 (1.4)	2 (2.7)	1 (1.4)
Renal and Urinary Disorders			
Pollakiuria	1 (1.4)	1 (1.4)	3 (4.2)
Renal Impairment	0	1 (1.4)	2 (2.8)
Vascular Disorders			
Peripheral Arterial Occlusive Disease	0	0	2 (2.8)

Combination with a Metformin and a Sulfonylurea (Studies DIA3002 and DIA3015)

The incidence of adverse events, reported regardless of causality in $\geq 2\%$ of patients treated with INVOKANA[®] 100 mg or 300 mg and more frequently than in the placebo groups, in studies of INVOKANA[®] as add-on combination therapy with metformin and a sulfonylurea, is provided in Table 4. The core assessment period was 26 weeks for the placebo-controlled study (DIA3002) and 52 weeks for the active-controlled study with sitagliptin (DIA3015).

Table 4: Adverse events (regardless of causality) reported in $\geq 2\%$ of patients treated with INVOKANA[®] and more frequently than in the placebo groups* in double-blind clinical trials of INVOKANA[®] in add-on combination use with metformin and a sulfonylurea, and compared to placebo (Study DIA3002) or sitagliptin (Study DIA3015)

System Organ Class / Preferred Term	Study DIA3002 (26 weeks)			Study DIA3015 (52 weeks)	
	Placebo+ Metformin + Sulfonylurea n=156 n (%)	INVOKANA [®] 100 mg + Metformin + Sulfonylurea n=157 n (%)	INVOKANA [®] 300 mg + Metformin + Sulfonylurea N=156 n (%)	INVOKANA [®] 300 mg + Metformin + Sulfonylurea n=377 n (%)	Sitagliptin 100 mg+ Metformin + Sulfonylurea n=378 n (%)
Ear and Labyrinth Disorders					
Vertigo	1 (0.6)	1 (0.6)	1 (0.6)	14 (3.7)	11 (2.9)
Gastrointestinal Disorders					
Abdominal Pain	1 (0.6)	2 (1.3)	1 (0.6)	8 (2.1)	6 (1.6)
Abdominal Pain Upper	2 (1.3)	1 (0.6)	1 (0.6)	10 (2.7)	2 (0.5)
Constipation	0	4 (2.5)	5 (3.2)	9 (2.4)	3 (0.8)
Diarrhea	5 (3.2)	5 (3.2)	10 (6.4)	17 (4.5)	26 (6.9)
Nausea	1 (0.6)	2 (1.3)	4 (2.6)	9 (2.4)	11 (2.9)
Infections and Infestations					
Bronchitis	3 (1.9)	4 (2.5)	3 (1.9)	1 (0.3)	11 (2.9)
Influenza	7 (4.5)	2 (1.3)	3 (1.9)	22 (5.8)	15 (4.0)
Nasopharyngitis	4 (2.6)	6 (3.8)	8 (5.1)	33 (8.8)	38 (10.1)
Sinusitis	3 (1.9)	4 (2.5)	2 (1.3)	8 (2.1)	8 (2.1)
Tooth Abscess	0	4 (2.5)	1 (0.6)	0	2 (0.5)
Upper Respiratory Tract Infection	10 (6.4)	17 (10.8)	6 (3.8)	33 (8.8)	21 (5.6)
Urinary Tract Infection	8 (5.1)	9 (5.7)	8 (5.1)	15 (4.0)	19 (5.0)
Vulvovaginal Mycotic Infection	2 (1.3)	8 (5.1)	8 (5.1)	12 (3.2)	5 (1.3)
Metabolism and Nutrition Disorders					
Decreased Appetite	1 (0.6)	0	4 (2.6)	4 (1.1)	5 (1.3)
Hypoglycemia	6 (3.8)	11 (7.0)	9 (5.8)	66 (17.5)	75 (19.8)
Musculoskeletal and Connective Tissue Disorders					
Arthralgia	4 (2.6)	7 (4.5)	7 (4.5)	17 (4.5)	8 (2.1)
Back Pain	4 (2.6)	2 (1.3)	5 (3.2)	8 (2.1)	15 (4.0)
Musculoskeletal Pain	1 (0.6)	0	3 (1.9)	8 (2.1)	6 (1.6)
Nervous System Disorders					
Headache	4 (2.6)	5 (3.2)	2 (1.3)	29 (7.7)	27 (7.1)
Renal and Urinary Disorders					
Pollakiuria	1 (0.6)	4 (2.5)	3 (1.9)	6 (1.6)	5 (1.3)
Reproductive System and Breast Disorders					
Vulvovaginal Pruritus	0	1 (0.6)	3 (1.9)	15 (4.0)	1 (0.3)

*In either study

Combination with Metformin and Pioglitazone (Study DIA3012)

The incidence of adverse events, reported regardless of causality in $\geq 2\%$ of patients treated with INVOKANA[®] 100 mg or 300 mg and more frequently than in the placebo group, in a study of INVOKANA[®] as add-on combination therapy with metformin and pioglitazone, is provided in Table 5. The core assessment period was 26 weeks for this placebo-controlled study.

Table 5: Adverse events (regardless of causality) reported in $\geq 2\%$ of patients treated with INVOKANA[®] and more frequently than in the placebo group in a double-blind clinical trial of INVOKANA[®] in add-on combination use with metformin and pioglitazone, and compared to placebo (Study DIA3012)

System Organ Class / Preferred Term	Placebo + Metformin+ Pioglitazone n=115 n (%)	INVOKANA[®] 100 mg + Metformin + Pioglitazone n=113 n (%)	INVOKANA[®] 300 mg + Metformin + Pioglitazone n=114 n (%)
Gastrointestinal Disorders			
Gastritis	2 (1.7)	4 (3.5)	0
General Disorders and Administration Site Conditions			
Fatigue	2 (1.7)	1 (0.9)	4 (3.5)
Edema Peripheral	2 (1.7)	2 (1.8)	4 (3.5)
Thirst	0	5 (4.4)	4 (3.5)
Infections and Infestations			
Nasopharyngitis	6 (5.2)	6 (5.3)	11 (9.6)
Sinusitis	2 (1.7)	1 (0.9)	3 (2.6)
Upper Respiratory Tract Infection	7 (6.1)	9 (8.0)	5 (4.4)
Vulvovaginal Candidiasis	0	1 (0.9)	3 (2.6)
Vulvovaginal Mycotic Infection	0	3 (2.7)	6 (5.3)
Investigations			
Weight Decreased	1 (0.9)	1 (0.9)	3 (2.6)
Metabolism and Nutrition Disorders			
Hypoglycemia	2 (1.7)	1 (0.9)	6 (5.3)
Musculoskeletal and Connective Tissue Disorders			
Arthralgia	2 (1.7)	1 (0.9)	6 (5.3)
Back Pain	3 (2.6)	8 (7.1)	5 (4.4)
Pain in Extremity	1 (0.9)	4 (3.5)	3 (2.6)
Nervous System Disorders			
Dizziness	1 (0.9)	4 (3.5)	3 (2.6)
Headache	4 (3.5)	3 (2.7)	5 (4.4)
Renal and Urinary Disorders			
Pollakiuria	1 (0.9)	5 (4.4)	7 (6.1)
Reproductive System and Breast Disorders			
Balanitis	0	3 (2.7)	0
Respiratory, Thoracic and Mediastinal Disorders			
Oropharyngeal Pain	2 (1.7)	3 (2.7)	0
Vascular Disorders			
Hypotension	3 (2.6)	3 (2.7)	0

Combination with Metformin and Sitagliptin (Study DIA4004)

The incidence of adverse events, reported regardless of causality in $\geq 2\%$ of patients treated with INVOKANA[®] and more frequently than in the placebo group, is provided in [Table 6](#) below. The assessment period was 26 weeks for this placebo-controlled study.

Table 6. Adverse events (regardless of causality) reported in $\geq 2\%$ of patients treated with INVOKANA[®] and more frequently than in the placebo group in a double-blind clinical trial of INVOKANA[®] in add-on combination use with metformin and sitagliptin, and compared to placebo (Study DIA4004)

System Organ Class / Preferred Term	Placebo + Metformin+ Sitagliptin n=108 n (%)	INVOKANA[®]¹ + Metformin + Sitagliptin n=108² n (%)
Musculoskeletal and Connective Tissue Disorders		
Back pain	1 (0.9)	3 (2.8)
Pain in Extremity	1 (0.9)	3 (2.8)
Psychiatric Disorders		
Depression	0	3 (2.8)

¹ 100 mg to 300 mg up-titration at Week 6

² 10 subjects did not up-titrate to canagliflozin 300 mg, 3 of whom completed Week 26

Combination with Insulin with or without Metformin (Study DIA3008 Insulin Substudy)

The incidence of adverse events, reported regardless of causality in $\geq 2\%$ of patients treated with INVOKANA[®] 100 mg or 300 mg and more frequently than in the placebo group, in a study of INVOKANA[®] as add-on combination therapy with insulin is provided in [Table 7](#), and as add-on combination therapy with insulin and metformin from the same study is provided in [Table 8](#). The core assessment period was 18 weeks for this placebo-controlled study.

Table 7: Adverse events (regardless of causality) reported in $\geq 2\%$ of patients treated with INVOKANA[®] and more frequently than in the placebo group in a double-blind clinical trial of INVOKANA[®] in add-on combination use with insulin and compared to placebo (Study DIA3008 - Insulin Substudy)

System Organ Class / Preferred Term	Placebo + Insulin n=187 n (%)	INVOKANA [®] 100 mg + Insulin n=183 n (%)	INVOKANA [®] 300 mg + Insulin n=184 n (%)
Ear and labyrinth disorders			
Vertigo	2 (1.1)	2 (1.1)	5 (2.7)
Gastrointestinal disorders			
Abdominal pain upper	4 (2.1)	4 (2.2)	1 (0.5)
Constipation	3 (1.6)	4 (2.2)	2 (1.1)
Dry mouth	1 (0.5)	4 (2.2)	1 (0.5)
Nausea	2 (1.1)	5 (2.7)	3 (1.6)
General disorders and administration site conditions			
Asthenia	1 (0.5)	0	4 (2.2)
Fatigue	1 (0.5)	8 (4.4)	3 (1.6)
Infections and infestations			
Bronchitis	4 (2.1)	2 (1.1)	5 (2.7)
Influenza	1 (0.5)	4 (2.2)	2 (1.1)
Upper respiratory tract infection	6 (3.2)	8 (4.4)	5 (2.7)
Urinary tract infection	3 (1.6)	3 (1.6)	4 (2.2)
Investigations			
Blood creatinine increased	3 (1.6)	7 (3.8)	3 (1.6)
Blood urea increased	1 (0.5)	4 (2.2)	3 (1.6)
Metabolism and nutrition disorders			
Hypoglycemia	12 (6.4)	15 (8.2)	20 (10.9)
Musculoskeletal and connective tissue disorders			
Back pain	4 (2.1)	5 (2.7)	6 (3.3)
Osteoarthritis	3 (1.6)	4 (2.2)	0
Pain in extremity	1 (0.5)	0	5 (2.7)
Nervous system disorders			
Dizziness	2 (1.1)	0	4 (2.2)
Headache	4 (2.1)	6 (3.3)	4 (2.2)
Renal and urinary disorders			
Pollakiuria	0	7 (3.8)	7 (3.8)
Reproductive system and breast disorders			
Balanitis	0	3 (1.6)	4 (2.2)
Vulvovaginal pruritus	0	5 (2.7)	0
Skin and subcutaneous tissue disorders			
Rash	2 (1.1)	5 (2.7)	2 (1.1)
Vascular disorders			
Hypotension	0	5 (2.7)	8 (4.3)

Table 8: Adverse events (regardless of causality) reported in $\geq 2\%$ of patients treated with INVOKANA[®] and more frequently than in the placebo group in a double-blind clinical trial of INVOKANA[®] in add-on combination use with insulin and metformin, and compared to placebo (Study DIA3008 - Insulin Substudy)

System Organ Class / Preferred Term	Placebo + Insulin + Metformin n=244 n (%)	INVOKANA [®] 100 mg + Insulin + Metformin n=241 n (%)	INVOKANA [®] 300 mg + Insulin + Metformin n=246 n (%)
Gastrointestinal disorders			
Constipation	2 (0.8)	1 (0.4)	8 (3.3)
Diarrhea	7 (2.9)	4 (1.7)	14 (5.7)
Dyspepsia	0	2 (0.8)	5 (2.0)
Nausea	5 (2.0)	5 (2.1)	8 (3.3)
General disorders and administration site conditions			
Fatigue	4 (1.6)	6 (2.5)	8 (3.3)
Thirst	0	2 (0.8)	10 (4.1)
Infections and infestations			
Bronchitis	5 (2.0)	7 (2.9)	3 (1.2)
Nasopharyngitis	22 (9.0)	22 (9.1)	13 (5.3)
Urinary tract infection	4 (1.6)	3 (1.2)	10 (4.1)
Vulvovaginal mycotic infection	2 (0.8)	4 (1.7)	5 (2.0)
Metabolism and nutrition disorders			
Hypoglycemia	21 (8.6)	23 (9.5)	23 (9.3)
Musculoskeletal and connective tissue disorders			
Arthralgia	3 (1.2)	8 (3.3)	4 (1.6)
Back pain	5 (2.0)	3 (1.2)	13 (5.3)
Pain in extremity	4 (1.6)	7 (2.9)	6 (2.4)
Nervous system disorders			
Dizziness	0	1 (0.4)	6 (2.4)
Headache	7 (2.9)	8 (3.3)	7 (2.8)
Renal and urinary disorders			
Pollakiuria	1 (0.4)	7 (2.9)	18 (7.3)
Reproductive system and breast disorders			
Balanitis	1 (0.4)	7 (2.9)	9 (3.7)
Vascular disorders			
Hypertension	3 (1.2)	8 (3.3)	1 (0.4)

Less Common Clinical Trial Adverse Drug Reactions (<2%)¹

Metabolism and nutrition disorders: dehydration²

Nervous system disorders: dizziness postural², syncope²

Skin and subcutaneous tissue disorders: rash³, urticaria

Vascular disorders: hypotension², orthostatic hypotension²

Description of Selected Adverse Reactions

Diabetic ketoacidosis: Cases of DKA, a serious life-threatening condition requiring urgent hospitalization, have been reported in patients with type 2 diabetes mellitus treated with SGLT2 inhibitors, including INVOKANA[®]. In the on-treatment analysis of the CANVAS/CANVAS-R integrated dataset, the adjusted incidence rates of adjudicated diabetic ketoacidosis were 0.08 (0.2%, 14/5,790) and 0.01 (<0.1%, 1/4,344) per 100 subject-years, for the combined canagliflozin and the placebo groups, respectively. Fatal cases of DKA have been reported in patients treated with INVOKANA[®]. The risk of DKA during INVOKANA[®] treatment was greater in patients with eGFR <60 mL/min/1.73 m² than in patients with normal renal function or mild renal impairment. INVOKANA[®] is not indicated and should not be used in patients with type 1 diabetes. In a number of reported cases, the presentation of the condition was atypical with blood glucose values below 13.9 mmol/L (250 mg/dL) (see **WARNINGS AND PRECAUTIONS, Endocrine and Metabolism**).

In a long-term renal outcomes study in patients with type 2 diabetes and diabetic nephropathy, on-treatment incidence rates of adjudicated events of DKA were 0.22 (0.5%, 11/2,200) and 0.02 (<0.1%, 1/2,197) per 100 patient-years with INVOKANA[®] 100 mg and placebo, respectively; of the 12 patients with DKA, 7 (6 on canagliflozin 100 mg and 1 on placebo) had an eGFR before treatment of 30 to < 45 mL/min/1.73m². Cases of DKA in the canagliflozin group occurred in the setting of an intercurrent illness requiring hospitalization (8 of 11 subjects), or with low beta cell function reserve (3 of 11 subjects).

Reduced intravascular volume: In the pooled analysis of the four 26-week, placebo-controlled studies, the incidence of all adverse reactions related to reduced intravascular volume (e.g., postural dizziness, orthostatic hypotension, hypotension, dehydration, and syncope) was 1.2% for INVOKANA[®] 100 mg, 1.3% for INVOKANA[®] 300 mg, and 1.1% for placebo. The incidence of these adverse reactions with INVOKANA[®] treatment in the two active-controlled studies was similar to comparators.

¹ Adverse drug reactions (ADRs) were identified based on a comprehensive assessment of biological plausibility, mechanism of action, dose dependence in incidence rate, time of onset, seriousness and consistency of findings across four, 26-week placebo-controlled Phase 3 clinical studies. Additional supportive safety analyses were conducted on a large pooled dataset from eight active- and placebo-controlled Phase 3 clinical studies.

² Related to reduced intravascular volume (see Adverse reactions related to reduced intravascular volume).

³ Rash includes the terms: rash erythematous, rash generalized, rash macular, rash maculopapular, rash papular, rash pruritic, rash pustular, and rash vesicular

In one of the dedicated long-term cardiovascular studies (CANVAS), where patients were generally older with a higher prevalence of comorbidities, the incidence rate of adverse reactions related to reduced intravascular volume were 2.34 with INVOKANA[®] 100 mg, 2.87 with INVOKANA[®] 300 mg, and 1.85 with placebo, events per 100 patient-years of exposure.

In the long-term renal outcomes trial, the incidence of hypotension was 2.8% in the INVOKANA[®] 100 mg group and 1.5% in the placebo group.

To assess risk factors for these adverse reactions, a larger pooled analysis (N=12,441) of patients from 13 controlled Phase 3 and Phase 4 studies including both doses of INVOKANA[®] was conducted. In this pooled analysis, patients on loop diuretics, patients with moderate renal impairment (eGFR 30 to <60 mL/min/1.73 m²), and patients ≥75 years of age had higher incidences of these reactions. For patients on loop diuretics, the incidence rates were 4.98 on INVOKANA[®] 100 mg and 5.67 on INVOKANA[®] 300 mg compared to 4.15 events per 100 patient-years of exposure in the control group. For patients with a baseline eGFR 30 to <60 mL/min/1.73 m², the incidence rates were 5.24 on INVOKANA[®] 100 mg and 5.35 on INVOKANA[®] 300 mg compared to 3.11 events per 100 patient-years of exposure in the control group. In patients ≥75 years of age, the incidence rates were 5.27 on INVOKANA[®] 100 mg and 6.08 on INVOKANA[®] 300 mg compared to 2.41 events per 100 patient-years of exposure in the control group (see **WARNINGS AND PRECAUTIONS, DOSING AND ADMINISTRATION** and **ACTION AND CLINICAL PHARMACOLOGY, Special Populations and Conditions**).

Hypoglycemia: In individual clinical trials (see **CLINICAL TRIALS**), episodes of hypoglycemia occurred at a higher rate when INVOKANA[®] was co-administered with insulin or sulfonylurea ([Table 9](#) see **WARNINGS AND PRECAUTIONS** and **DOSAGE AND ADMINISTRATION**).

Table 9: Incidence of Hypoglycemia¹ in Controlled Clinical Studies

Monotherapy (26 weeks)	Placebo (N=192)	INVOKANA[®] 100 mg (N=195)	INVOKANA[®] 300 mg (N=197)
Overall [N (%)]	5 (2.6)	7 (3.6)	6 (3.0)
In Combination with Metformin (26 weeks)	Placebo + Metformin (N=183)	INVOKANA[®] 100 mg + Metformin (N=368)	INVOKANA[®] 300 mg + Metformin (N=367)
Overall [N (%)]	3 (1.6)	16 (4.3)	17 (4.6)
Severe [N (%)] ²	0 (0)	1 (0.3)	1 (0.3)
In Combination with Metformin (52 weeks)	Glimepiride + Metformin (N=482)	INVOKANA[®] 100 mg + Metformin (N=483)	INVOKANA[®] 300 mg + Metformin (N=485)
Overall [N (%)]	165 (34.2)	27 (5.6)	24 (4.9)
Severe [N (%)] ²	15 (3.1)	2 (0.4)	3 (0.6)
In Combination with Sulfonylurea (18 weeks)	Placebo + Sulfonylurea (N=69)	INVOKANA[®] 100 mg + Sulfonylurea (N=74)	INVOKANA[®] 300 mg + Sulfonylurea (N=72)
Overall [N (%)]	4 (5.8)	3 (4.1)	9 (12.5)
In Combination with Metformin + Sulfonylurea (26 weeks)	Placebo + Metformin + Sulfonylurea (N=156)	INVOKANA[®] 100 mg + Metformin + Sulfonylurea (N=157)	INVOKANA[®] 300 mg + Metformin + Sulfonylurea (N=156)
Overall [N (%)]	24 (15.4)	43 (27.4)	47 (30.1)
Severe [N (%)] ²	1 (0.6)	1 (0.6)	0
In Combination with Metformin + Sulfonylurea (52 weeks)	Sitagliptin + Metformin + Sulfonylurea (N=378)		INVOKANA[®] 300 mg + Metformin + Sulfonylurea (N=377)
Overall [N (%)]	154 (40.7)		163 (43.2)
Severe [N (%)] ²	13 (3.4)		15 (4.0)
In Combination with Metformin + Pioglitazone (26 weeks)	Placebo + Metformin + Pioglitazone (N=115)	INVOKANA[®] 100 mg + Metformin + Pioglitazone (N=113)	INVOKANA[®] 300 mg + Metformin + Pioglitazone (N=114)
Overall [N (%)]	3 (2.6)	3 (2.7)	6 (5.3)
In Combination with Metformin + Sitagliptin (26 weeks)	Placebo + Metformin + Sitagliptin (N=108)	INVOKANA[®] ³ + Metformin + Sitagliptin (N=108)⁴	
Overall [N (%)]	2 (1.9)	4 (3.7)	
Severe [N (%)] ²	0	0	
In Combination with Insulin (18 weeks)	Placebo (N=565)	INVOKANA[®] 100 mg (N=566)	INVOKANA[®] 300 mg (N=587)
Overall [N (%)]	208 (36.8)	279 (49.3)	285 (48.6)
Severe [N (%)] ²	14 (2.5)	10 (1.8)	16 (2.7)

¹ Number of patients experiencing at least one event of hypoglycemia based on either biochemically documented episodes (any glucose value ≤ 3.89 mmol/L) or severe hypoglycemic events in the intent-to-treat population.

² Severe episodes of hypoglycemia were defined as those where the patient: required the assistance of another person to recover; lost consciousness; or experienced a seizure (regardless of whether biochemical documentation of a low glucose value was obtained).

³ 100 mg to 300 mg up-titration at Week 6

⁴ 10 subjects did not up-titrate to canagliflozin 300 mg, 3 of whom completed Week 26

Fournier's gangrene (Necrotizing fasciitis of the perineum)

Fournier's gangrene was identified as a SGLT2i class adverse reaction based on spontaneous event reporting. These events had not been previously identified as ADRs because there were very few subjects in the canagliflozin Phase 3 and Phase 4 clinical development program (including the CANVAS and CREDENCE programs) with adverse events of Fournier's gangrene (incidences were <0.1% in the canagliflozin and comparator groups). All 4 events of Fournier's gangrene (2 subjects treated with canagliflozin and 2 subjects treated with comparator) in the canagliflozin Phase 3 and Phase 4 clinical development program were serious.

Genital mycotic infections: Vulvovaginal candidiasis (including vulvovaginitis and vulvovaginal mycotic infection) was reported in 10.4% and 11.4% of female patients treated with INVOKANA[®] 100 mg and INVOKANA[®] 300 mg, respectively, compared to 3.2% in placebo-treated female patients. Most reports of vulvovaginal candidiasis occurred during the first four months of treatment with canagliflozin. Among female patients taking INVOKANA[®], 2.3% experienced more than one infection. Overall, 0.7% of all female patients discontinued INVOKANA[®] due to vulvovaginal candidiasis (see **WARNINGS AND PRECAUTIONS**).

Candidal balanitis or balanoposthitis was reported in 4.2% and 3.7% of male patients treated with INVOKANA[®] 100 mg and INVOKANA[®] 300 mg, respectively, compared to 0.6% in placebo-treated male patients. Among male patients taking INVOKANA[®], 0.9% had more than one infection. Overall, 0.5% of male patients discontinued INVOKANA[®] due to candidal balanitis or balanoposthitis. In uncircumcised males in a pooled analysis of 10 controlled studies, the incidence rate of phimosis was 0.56 events per 100 patient-years of exposure in patients treated with canagliflozin and 0.05 events per 100 patient-years in patients treated with comparator. In this pooled analysis, the incidence rate of circumcision was 0.38 events per 100 patient-years of exposure in male patients treated with canagliflozin compared to 0.10 events per 100 patients-years in male patients treated with comparator (see **WARNINGS AND PRECAUTIONS**).

In the CANVAS integrated dataset, the adjusted-incidence rates of any male mycotic genital infection were 3.17 and 0.96 per 100 patient-years in the combined canagliflozin and placebo groups, respectively.

Urinary tract infections: Urinary tract infections were more frequently reported for INVOKANA[®] 100 mg and 300 mg (5.9% versus 4.3%, respectively) compared to 4.0% with placebo. Most infections were mild to moderate with no increase in the occurrence of serious adverse events (see **WARNINGS AND PRECAUTIONS**). Subjects responded to standard treatments while continuing canagliflozin treatment. The incidence of recurrent infections was not increased with canagliflozin.

Falls: In the pool of all Phase 3 studies, the incidence rate of AEs coded as related to a fall was 7.3, 8.0, and 11.8 per 1000 patient years of exposure to comparator, INVOKANA[®] 100 mg, and INVOKANA[®] 300 mg, respectively.

Bone fractures: In a cardiovascular study (CANVAS) of 4,327 patients with established or at least two risk factors for cardiovascular disease, the incidence rates of all adjudicated bone

fracture were 1.59, 1.79, and 1.09 per 100 patient-years of follow up to INVOKANA[®] 100 mg, INVOKANA[®] 300 mg, and placebo, respectively, with the fracture imbalance initially occurring within the first 26 weeks of therapy.

In a second cardiovascular study (CANVAS-R) of 5,807 patients with established or at least two risk factors for cardiovascular disease, the incidence rates of all adjudicated bone fracture were 1.14 and 1.32 events per 100 patient-years of follow up to INVOKANA[®] and placebo, respectively.

In a long-term renal outcomes study (CREDENCE) of 4,397 patients with type 2 diabetes and diabetic nephropathy, the incidence rates of all adjudicated bone fracture were 1.18 and 1.21 events per 100 patient-years of follow-up for INVOKANA[®] 100 mg and placebo, respectively. In other type 2 diabetes studies with INVOKANA[®], which enrolled a general diabetes population of 7,729 patients, the incidence rates of all adjudicated bone fracture were 1.18 and 1.08 events per 100 patient-years of follow up to INVOKANA[®] and control, respectively.

Decreases in Bone Mineral Density: Bone mineral density (BMD) was measured by dual-energy X-ray absorptiometry in a clinical trial of 714 older adults (mean age 64 years). At 2 years, patients randomized to INVOKANA[®] 100 mg and INVOKANA[®] 300 mg had placebo-corrected declines in BMD at the total hip of 0.9% and 1.2%, respectively, and at the lumbar spine of 0.3% and 0.7%, respectively. Placebo-adjusted BMD declines were 0.1% at the femoral neck for both INVOKANA[®] doses and 0.4% at the distal forearm for patients randomized to INVOKANA[®] 300 mg. The placebo-adjusted change at the distal forearm for patients randomized to INVOKANA[®] 100 mg was 0%.

Photosensitivity: In the CANVAS outcome trials integrated dataset, the adjusted-incidence rates of photosensitivity adverse events were 1.03 (0.3%, 19/5790) and 0.26 (0.1%, 3/4344) events per 1,000 subject-years in the combined canagliflozin and the placebo groups, respectively. In a dataset from 12 other phase 3 or 4 trials (excluding the CANVAS outcome trials) that enrolled a diabetic population of 8114 patients, an imbalance in phototoxicity adverse events was not seen with INVOKANA[®] relative to control.

Skin ulcers and peripheral ischemia: In the pool of 8 clinical studies with 78 weeks of mean duration of exposure, skin ulcers occurred in 0.7%, 1.1%, and 1.5% of patients and peripheral ischemia occurred in 0.1%, 0.4%, and 0.2% of patients receiving comparator, INVOKANA[®] 100 mg, and INVOKANA[®] 300 mg, respectively. An imbalance in these events generally were seen within the first 24 weeks of treatment and occurred in patients with known or at high risk for atherosclerotic disease, longer duration of diabetes, presence of diabetic complications, and diuretic use. In the on-treatment analysis set of the CREDENCE renal outcomes trial, there was a higher incidence rate of adverse events of diabetic foot reported in the canagliflozin group compared with the placebo group: 8.47 (43 subjects) and 4.89 (24 subjects) per 1,000 subject-years, respectively.

Renal Cell Carcinoma: In the CANVAS outcome trials integrated dataset, the adjusted-incidence rates of any renal cell carcinoma adverse event were 0.62 (0.2%, 14/5790) and 0.21

(0.1%, 3/4344) per 1,000 subject-years in the canagliflozin and the placebo groups, respectively. Whether this numerical imbalance is related to INVOKANA[®] treatment is unknown.

Lower limb amputation: An approximately 2-fold-increased risk of lower limb amputations associated with INVOKANA[®] use was observed in CANVAS and CANVAS-R, two large, randomized, placebo-controlled trials evaluating patients with type 2 diabetes who had either established cardiovascular disease or were at risk for cardiovascular disease. The imbalance occurred as early as the first 26 weeks of therapy. Patients in CANVAS and CANVAS-R were followed for an average of 5.7 and 2.1 years, respectively. The amputation data for CANVAS and CANVAS-R are shown in [Table 10](#) and [Table 11](#), respectively. See **WARNINGS AND PRECAUTIONS, Cardiovascular**.

Table 10: CANVAS Amputations

	Placebo (N=1441)	INVOKANA [®] 100 mg (N=1445)	INVOKANA [®] 300 mg (N=1441)	INVOKANA [®] Pooled (N=2886)
Patients with an amputation, n (%)	22 (1.5)	50 (3.5)	45 (3.1)	95 (3.3)
Total amputations	33	83	79	162
Amputation incidence rate (per 1000 patient-years)	2.8	6.2	5.5	5.9
Hazard ratio (95% CI)		2.24 (1.36, 3.69)	2.01 (1.20, 3.34)	2.12 (1.34, 3.38)

Note: Incidence is based on the number of patients with at least one amputation, and not the total number of amputation events. A patient's follow-up is calculated from Day 1 to the first amputation event date. Some patients had more than one amputation.

Table 11: CANVAS-R Amputations

	Placebo (N=2903)	INVOKANA [®] 100 mg (with up-titration to 300 mg) (N=2904)
Patients with an amputation, n (%)	25 (0.9)	45 (1.5)
Total amputations	36	59
Amputation incidence rate (per 1000 patient-years)	4.2	7.5
Hazard Ratio (95% CI)	--	1.80 (1.10, 2.93)

Note: Incidence is based on the number of patients with at least one amputation, and not the total number of amputation events. A patient's follow-up is calculated from Day 1 to the first amputation event date. Some patients had more than one amputation.

In a datapool of patients from 12 other phase 3 or 4 trials (excluding CANVAS program) that enrolled a diabetic population of 8114 patients, the majority of which were without cardiovascular disease, no difference in lower limb amputation risk was observed on INVOKANA[®] relative to control.

The risk of lower limb amputations associated with the use of INVOKANA[®] 100 mg relative to placebo was 12.3 vs 11.2 events per 1000 patient-years, respectively in CREDENCE, a long-term renal outcomes study of 4,397 patients with type 2 diabetes and diabetic nephropathy, with

a mean follow-up duration of 136 weeks (see [Table 12](#) and **WARNINGS AND PRECAUTIONS**).

Table 12: Lower limb amputations CREDESCENCE (On-study analysis)

	Placebo (N=2197)	INVOKANA® 100 mg (N=2200)
Patients with an amputation, n (%)	63 (2.9)	70 (3.2)
Total amputations	96	87
Amputation incidence rate (per 1000 patient-years)	11.2	12.3
Hazard Ratio (95% CI)	--	1.11 (0.79, 1.56)

Note: Incidence is based on the number of patients with at least one amputation, and not the total number of amputation events. A patient's follow-up is calculated from Day 1 to the first amputation event date. Some patients had more than one amputation.

Adverse Reactions in Specific Populations

Elderly Patients: Compared to younger patients, patients 65 years and older had a higher incidence of adverse reactions related to reduced intravascular volume with INVOKANA®, including hypotension, postural dizziness, orthostatic hypotension, syncope, and dehydration. In particular, in patients ≥75 years of age, adverse reactions related to reduced intravascular volume occurred with incidence rates of 5.27, 6.08, and 2.41 events per 100 patient-years of exposure for INVOKANA® 100 mg, INVOKANA® 300 mg, and the control group, respectively. Decreases in eGFR (-3.41 and -4.67 mL/min/1.73 m²) were reported with INVOKANA® 100 mg and 300 mg, respectively, compared to the control group (-4.15 mL/min/1.73 m²) (see **WARNINGS AND PRECAUTIONS** and **DOSAGE AND ADMINISTRATION**).

Patients with Moderate Renal Impairment

Patients with Type 2 Diabetes Mellitus and an eGFR 45 to <60 mL/min/1.73 m² Treated for Glycemic Control or for the Reduction of MACE: In a pooled analysis of patients (N=1087) with a baseline eGFR 45 to <60 mL/min/1.73 m², the incidence rates of adverse reactions related to reduced intravascular volume were 4.61 for INVOKANA® 100 mg and 4.37 with INVOKANA® 300 mg relative to 3.00 events per 100 patient-years of exposure for placebo (see **WARNINGS AND PRECAUTIONS** and **DOSAGE AND ADMINISTRATION**). Serum creatinine levels increased from baseline to end of treatment by 5.92 and 6.98 µmol/L for INVOKANA® 100 mg and 300 mg, respectively, relative to 7.03 µmol/L with placebo. Blood urea nitrogen (BUN) levels increased from baseline to end of treatment by 0.92 and 0.77 µmol/L for INVOKANA® 100 mg and 300 mg, respectively, relative to 0.57 µmol/L with placebo. The incidence rates of decreases in eGFR (<80 mL/min/1.73 m² and >30% decrease from baseline) at any time during treatment were 5.17, 6.62, and 5.82 events per 100 patient-years of exposure for INVOKANA® 100 mg, INVOKANA® 300 mg, and placebo, respectively. At the last post-baseline value, incidence rates for such decreases were 2.52 for patients treated with INVOKANA® 100 mg, 1.91 for patients treated with INVOKANA® 300 mg, and 3.20 events per 100 patient-years of exposure for placebo (see **WARNINGS AND PRECAUTIONS**).

The incidences of elevated serum potassium (>5.4 mEq/L and 15% above baseline) at any post-baseline value were 4.11 for INVOKANA[®] 100 mg, 4.33 for INVOKANA[®] 300 mg, and 3.8 events per 100 patient-years of exposure for placebo. Rare, more severe elevations were seen in patients with moderate renal impairment who had prior elevated potassium concentrations and/or who were on multiple medications that reduce potassium excretion, such as potassium-sparing diuretics and angiotensin-converting-enzyme (ACE) inhibitors.

Serum phosphate changes from baseline to end of treatment were 0.00 and 0.02 mmol/L for INVOKANA[®] 100 mg and 300 mg, respectively, compared to 0.00 mmol/L for placebo. The incidence rates of elevated serum phosphate (>1.65 mmol/L and 25% above baseline) at any post-baseline value were 0.93 for INVOKANA[®] 100 mg, 1.15 for INVOKANA[®] 300 mg and 0.71 events per 100 patient-years of exposure for placebo.

Patients with Type 2 Diabetes Mellitus and an eGFR 30 to <60 mL/min/1.73 m² Treated for Diabetic Nephropathy: In a long-term renal outcomes study in patients with type 2 diabetes and diabetic nephropathy, the incidence rate for renal-related adverse events was lower in the canagliflozin 100-mg group compared with the placebo group (7.23 and 10.55 per 100 patient-years in INVOKANA[®] 100mg and placebo, respectively).

For the subset of patients with an eGFR before treatment of 45 to <60 mL/min/1.73m², the incidence rates of adverse reactions related to volume depletion were similar: 2.3 events per 100 patient-years for INVOKANA[®] 100 mg and 2.6 events per 100 patient-years of exposure for placebo. In the same study, for patients with an eGFR 30 to <45mL/min/1.73m² the incidence rate was higher for INVOKANA[®] 100 mg (4.9 events per 100 patient-years) than for placebo (2.6 events per 100 patient-years).

Clinical Chemistry and Hematology Findings

Laboratory values, described below, are derived from the pooled analysis of 26-week, placebo-controlled clinical studies unless otherwise noted.

Increases in serum potassium: Mean percent changes from baseline in blood potassium were 0.5% and 1.0% for INVOKANA[®] 100 mg and 300 mg, respectively, compared to 0.6% for placebo. Episodes of elevated serum potassium (>5.4 mEq/L and 15% above baseline) were seen in 4.4% of patients treated with INVOKANA[®] 100 mg, 7.0% of patients treated with INVOKANA[®] 300 mg, and 4.8% of patients treated with placebo.

In a trial in patients with moderate renal impairment (eGFR 30 to <50 mL/min/1.73 m²), increases in serum potassium to >5.4 mEq/L and 15% above baseline were seen in 16.1%, 12.4%, and 27.0% of patients treated with placebo, INVOKANA[®] 100 mg, and INVOKANA[®] 300 mg, respectively. Elevations to ≥6.5 mEq/L occurred in 1.1%, 2.2%, and 2.2% of patients treated with placebo, INVOKANA[®] 100 mg, and INVOKANA[®] 300 mg, respectively.

In a long-term renal outcomes study in patients with type 2 diabetes and diabetic nephropathy, no increase in adverse events of hyperkalemia, and no absolute (> 6.5mEq/L) or relative (> upper

limit of normal and > 15% increase from baseline) increases in serum potassium were observed with INVOKANA® 100 mg relative to placebo.

Increases in serum creatinine and blood urea nitrogen (BUN): Mean percent changes from baseline in creatinine, with commensurate decreases in eGFR, were 2.8% and 4.0% for INVOKANA® 100 mg and 300 mg, respectively, compared to 1.5% for placebo. Mean percent increases from baseline in BUN were 17.1% and 18.0% for INVOKANA® 100 mg and 300 mg, respectively, compared to 2.7% for placebo. These changes were generally observed within six weeks of treatment initiation. Subsequently, serum creatinine concentrations gradually trended toward baseline and BUN levels remained stable.

The proportion of patients with larger decreases in eGFR (>30%) from baseline, occurring at any time during treatment, was 2.0% with INVOKANA® 100 mg and 4.1% with INVOKANA® 300 mg relative to 2.1% with placebo. At study end, decreases of >30% from baseline were seen for 0.7% of subjects with INVOKANA® 100 mg, 1.4% with INVOKANA® 300 mg, and 0.5% with placebo (see **WARNINGS AND PRECAUTIONS**). After discontinuation of INVOKANA® therapy, these changes in laboratory values improved or returned to baseline.

In an integrated analysis of data from two long-term cardiovascular outcome studies, patients treated with INVOKANA® experienced an initial fall in mean eGFR that thereafter stabilized (see [Figure 1](#)) whereas patients treated with placebo experienced a progressive decline in eGFR.

Figure 1: Adjusted mean eGFR over time

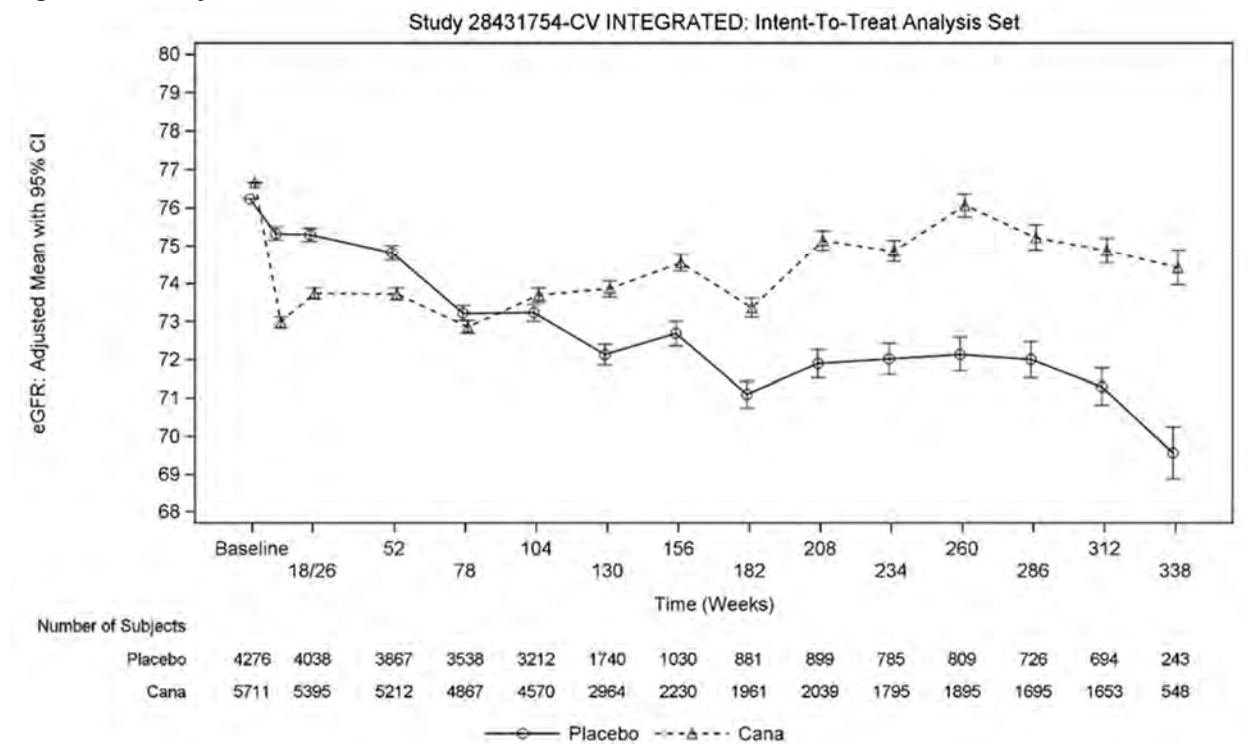

In a long-term renal outcomes trial, patients treated with INVOKANA[®] experienced an acute decrease in eGFR at Week 3, followed by an attenuated decline over time from week 3 to end of treatment. Placebo-treated patients demonstrated a progressive linear decline over time. After Week 52, the LS mean decrease in eGFR was smaller in the INVOKANA[®] 100 mg group than in the placebo group (Figure 2).

Figure 2: LS Mean Change From Baseline in eGFR Over Time (On-Treatment Analysis Set)

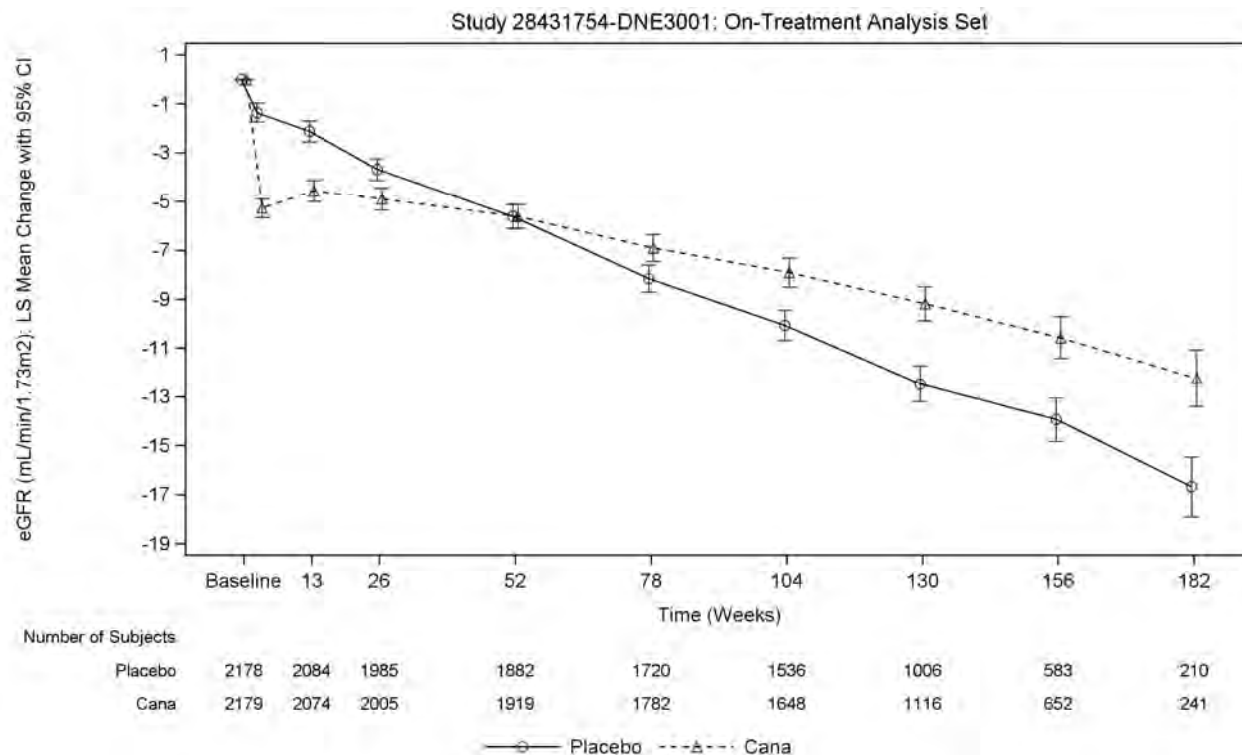

Lipid changes: Compared to placebo, mean increases from baseline in low density lipoprotein cholesterol (LDL-C) were 0.11 mmol/L (4.5%) and 0.21 mmol/L (8.0%) with INVOKANA[®] 100 mg and INVOKANA[®] 300 mg, respectively. Increases in total cholesterol of 0.12 mmol/L (2.5%) and 0.21 mmol/L (4.3%) were seen, relative to placebo, for INVOKANA[®] 100 mg and INVOKANA[®] 300 mg, respectively. Increases in non-HDL-C relative to placebo were 0.05 mmol/L (1.5%) and 0.13 mmol/L (3.6%) with INVOKANA[®] 100 mg and 300 mg, respectively. Increases in high-density lipoprotein cholesterol (HDL-C) were 0.06 mmol/L (5.4%), and 0.07 mmol/L (6.3%) relative to placebo for INVOKANA[®] 100 mg and INVOKANA[®] 300 mg, respectively. The LDL-C/HDL-C ratios did not change with either INVOKANA[®] dose compared to placebo.

Increases in hemoglobin: Mean hemoglobin concentration increased from baseline 4.7 g/L (3.5%) with INVOKANA[®] 100 mg and 5.1 g/L (3.8%) with INVOKANA[®] 300 mg, compared to a decrease of -1.8 g/L (-1.1%) with placebo. After 26 weeks of treatment, 0.8%, 4.0%, and 2.7%

of patients treated with placebo, INVOKANA[®] 100 mg, and INVOKANA[®] 300 mg, respectively, had a hemoglobin level above the upper limit of normal.

Increases in serum phosphate: Dose-related increases in serum phosphate levels were observed with INVOKANA[®]. In the pool of four placebo-controlled trials, the mean percent change in serum phosphate levels were 3.6% and 5.1% with INVOKANA[®] 100 mg and INVOKANA[®] 300 mg, respectively, compared to 1.5% with placebo. Episodes of elevated serum phosphate (>1.65 mmol/L and 25% above baseline) were seen in 0.6% and 1.6% of patients treated with INVOKANA[®] 100 mg and 300 mg, respectively, compared to 1.3% of patients treated with placebo.

Decreases in serum urate: Moderate decreases in the mean percent change from baseline in serum urate were observed in the INVOKANA[®] 100 mg and 300 mg groups (-10.1% and -10.6%, respectively) compared with placebo, where a slight increase from baseline (1.9%) was observed. Decreases in serum urate in the INVOKANA[®] groups were maximal or near maximal by Week 6 and maintained with dosing. A transient increase in urinary uric acid excretion was seen, which was not persistent.

Electrolytes: The following changes from baseline to end of treatment in serum electrolytes were observed during INVOKANA[®] treatment in the CANVAS integrated database.

Table 13: Placebo-adjusted Mean Changes from Baseline in Electrolytes at Week 18 or 26^a in the CANVAS program

Analyte [normal range, unit]	Baseline, mean (SE)	Placebo-corrected change from baseline at Week 18 or 26 ^a , mean (95%)	p-value
Sodium [135 – 145 mmol/L]			
INVOKANA [®]	139.3 (0.036)	0.40 (0.304; 0.496)	<0.001
Potassium [3.5 – 5.0 mmol/L]			
INVOKANA [®]	4.44 (0.006)	0.01 (-0.005; 0.028)	0.171
Magnesium [0.75 – 0.95 mmol/L]			
INVOKANA [®]	0.77 (0.001)	0.08 (0.074; 0.080)	<0.001
Bicarbonate [24 – 30 mmol/L]			
INVOKANA [®]	23.33 (0.036)	-0.41 (-0.504; -0.307)	<0.001
Phosphate [0.80-1.50 mmol/L]			
INVOKANA [®]	1.16 (0.002)	0.03 (0.028; 0.040)	<0.001
Calcium [2.07-2.64 mmol/L]			
INVOKANA [®]	2.41 (0.002)	0.02 (0.012, 0.020)	<0.001

^a CANVAS study blood chemistries obtained at week 18, CANVAS-R study blood chemistries obtained at week 26
SE = standard error

ANCOVA for Week 18 or 26 includes the baseline electrolyte as a linear covariate, and treatment and study as fixed effects.

The following shifts from normal range at baseline to below or above the normal range at worst value on treatment were reported in the treated set in the CANVAS integrated database:

- Increases in serum sodium above the upper limit of normal occurred more frequently in patients receiving INVOKANA[®] than in those receiving placebo (2.63 per 100 subject years for INVOKANA[®] and 1.80 per 100 subject years for placebo).
- Decreases in serum magnesium below the lower limit of normal occurred more frequently in patients receiving placebo (0.65 per 100 subject years for INVOKANA[®] and 3.80 per 100 subject years for placebo), whilst increases in serum magnesium above the upper limit of normal occurred more frequently in patients receiving INVOKANA[®] than in those receiving placebo (1.25 per 100 subject years for INVOKANA[®] and 0.88 per 100 subject years for placebo).
- Decreases of serum bicarbonate below the lower limit of normal occurred more frequently in patients receiving INVOKANA[®] than in those receiving placebo (2.91 per 100 subject years for INVOKANA[®], 2.39 per 100 subject years for placebo).
- Increases of serum phosphate above the upper limit of normal occurred more frequently in patients receiving INVOKANA[®] than in those receiving placebo (1.36 per 100 subject years for INVOKANA[®] and 1.00 per 100 subject years for placebo).

Post-Market Adverse Drug Reactions

Because these reactions were reported voluntarily from a population of uncertain size, it is not always possible to reliably estimate their frequency or establish a causal relationship to drug exposure.

Gastrointestinal Disorders: pancreatitis acute

Metabolism and nutrition disorders: diabetic ketoacidosis

Immune system disorders: anaphylactic reaction

Skin and subcutaneous tissue disorders: angioedema

Renal and urinary disorders: acute kidney injury, including acute renal failure (with or without volume depletion)

Genitourinary: severe urinary tract infections; urosepsis and pyelonephritis

Musculoskeletal: bone fractures

Infections and Infestations: Fournier's gangrene (necrotizing fasciitis of the perineum)

DRUG INTERACTIONS

Overview

In vitro assessment of interactions

The metabolism of canagliflozin is primarily via glucuronide conjugation mediated by UDP glucuronosyl transferase 1A9 (UGT1A9) and 2B4 (UGT2B4).

Canagliflozin did not induce CYP450 enzyme expression (3A4, 2C9, 2C19, 2B6, and 1A2) in cultured human hepatocytes. Canagliflozin did not inhibit the CYP450 isoenzymes (1A2, 2A6, 2C19, 2D6, or 2E1) and weakly inhibited CYP2B6, CYP2C8, CYP2C9, and CYP3A4 based on *in vitro* studies with human hepatic microsomes. Canagliflozin is a weak inhibitor of P-gp.

Canagliflozin is also a substrate of drug transporters P-glycoprotein (P-gp), Breast Cancer Resistance Protein (BCRP) and Multi-Drug Resistance-Associated Protein 2 (MRP2).

In vivo assessment of interactions

Specific clinical drug interaction studies were conducted to investigate the effects of co-administered drugs, inhibitors or inducers of the drug-metabolizing enzymes UGTs (1A9, 2B4), CYPs (3A4, 2C9) and transporters P-gp and MRP2 on canagliflozin pharmacokinetics. Clinical studies were also conducted to assess the inhibitory or induction effects of canagliflozin on the pharmacokinetics of the CYP (3A4, 2C9), P-gp, substrates and co-administered drugs (see **ACTION AND CLINICAL PHARMACOLOGY**).

Drug-Drug Interactions

Effects of other drugs on canagliflozin

In clinical studies, the effects of other drugs on canagliflozin were assessed. Cyclosporin (P-gp inhibitor), hydrochlorothiazide, oral contraceptives (ethinyl estradiol and levonorgestrel), metformin, and probenecid (UGT, MRP2, OATP, OAT1 and OAT3 inhibitor) had no clinically relevant effect on the pharmacokinetics of canagliflozin.

Table 14: Effect of Co-administered Drugs on Systemic Exposure of Canagliflozin

Co-administered Drug	Dose of Co-administered Drug ¹	Dose of Canagliflozin ¹	Geometric Mean Ratio (Ratio With/Without Co-administered Drug) No Effect = 1.0		Clinical Comment
			AUC ² (90% CI)	C _{max} (90% CI)	
Cyclosporin	400 mg	300 mg once daily for 8 days	1.23 (1.19; 1.27)	1.01 (0.91; 1.11)	No dosage adjustment for INVOKANA [®] required
Ethinyl estradiol and levonorgestrel	0.03 mg ethinyl estradiol and 0.15 mg levonorgestrel	200 mg once daily for 6 days	0.91 (0.88; 0.94)	0.92 (0.84; 0.99)	No dosage adjustment for INVOKANA [®] required
Hydrochlorothiazide	25 mg once daily for 35 days	300 mg once daily for 7 days	1.12 (1.08; 1.17)	1.15 (1.06; 1.25)	No dosage adjustment for INVOKANA [®] required
Metformin	2000 mg	300 mg once daily for 8 days	1.10 (1.05; 1.15)	1.05 (0.96; 1.16)	No dosage adjustment for INVOKANA [®] required
Probenecid	500 mg twice daily for 3 days	300 mg once daily for 17 days	1.21 (1.16; 1.25)	1.13 (1.00; 1.28)	No dosage adjustment for INVOKANA [®] required
Inducers of UGT enzymes / drug transporters					
Rifampin	600 mg once daily for 8 days	300 mg	0.49 (0.44; 0.54)	0.72 (0.61; 0.84)	Consider increasing the INVOKANA [®] dose to 300 mg once daily if patients are currently tolerating INVOKANA [®] 100 mg once daily (refer to DOSAGE AND ADMINISTRATION).
Phenytoin, phenobarbital, barbiturates, carbamazepine, ritonavir, efavirenz, or St. John's Wort	N/A ³				Consider increasing the INVOKANA [®] dose to 300 mg once daily if patients are currently tolerating INVOKANA [®] 100 mg once daily (refer to DOSAGE AND ADMINISTRATION).

¹ Single dose unless otherwise noted

² AUC_{inf} for drugs given as a single dose and AUC_{24h} for drugs given as multiple doses

³ N/A = Not applicable

Effects of canagliflozin on other drugs

Canagliflozin at steady-state had no clinically relevant effect on the pharmacokinetics of metformin, oral contraceptives (ethinyl estradiol and levonorgestrel-CYP3A4 substrates), glyburide (CYP2C9 substrate), simvastatin (CYP3A4 substrate), acetaminophen, hydrochlorothiazide, or warfarin (CYP2C9 substrate), in healthy subjects.

Inhibition of BCRP by canagliflozin cannot be excluded at an intestinal level and increased exposure may therefore occur for drugs transported by BCRP, e.g., certain statins like rosuvastatin and some anti-cancer agents.

Table 15: Effect of Canagliflozin on Systemic Exposure of Co-Administered Drugs

Co-Administered Drug	Dose of Co-Administered Drug ¹	Dose of Canagliflozin ¹	Geometric Mean Ratio (Ratio With/Without Co-Administered Drugs) No Effect = 1.0			Clinical Comment
				AUC ² (90% CI)	C _{max} (90% CI)	
Digoxin	0.5 mg once daily first day followed by 0.25 mg once daily for 6 days	300 mg once daily for 7 days	Digoxin	1.20 (1.12; 1.28)	1.36 (1.21; 1.53)	Patients taking INVOKANA [®] with concomitant digoxin should be monitored appropriately
Ethinyl estradiol and levonorgestrel	0.03 mg ethinyl estradiol and 0.15 mg levonorgestrel	200 mg once daily for 6 days	ethinyl estradiol	1.07 (0.99; 1.15)	1.22 (1.10; 1.35)	No dosage adjustment required for ethinyl estradiol and levonorgestrel
			Levonorgestrel	1.06 (1.00; 1.13)	1.22 (1.11; 1.35)	
Glyburide	1.25 mg	200 mg once daily for 6 days	Glyburide	1.02 (0.98; 1.07)	0.93 (0.85; 1.01)	No dosage adjustment required for glyburide
			3-cis-hydroxy-glyburide	1.01 (0.96; 1.07)	0.99 (0.91; 1.08)	
			4-trans-hydroxy-glyburide	1.03 (0.97; 1.09)	0.96 (0.88; 1.04)	
Hydrochlorothiazide	25 mg once daily for 35 days	300 mg once daily for 7 days	hydrochlorothiazide	0.99 (0.95; 1.04)	0.94 (0.87; 1.01)	No dosage adjustment required for hydrochlorothiazide
Metformin	2000 mg	300 mg once daily for 8 days	Metformin	1.20 (1.08; 1.34)	1.06 (0.93; 1.20)	No dosage adjustment required for metformin
Acetaminophen	1000 mg	300 mg twice daily for 25 days	Acetaminophen	1.06 ³ (0.98; 1.14)	1.00 (0.92; 1.09)	No dosage adjustment required for acetaminophen
Simvastatin	40 mg	300 mg once daily for 7 days	Simvastatin	1.12 (0.94; 1.33)	1.09 (0.91; 1.31)	No dosage adjustment required for simvastatin
			simvastatin acid	1.18 (1.03; 1.35)	1.26 (1.10; 1.45)	
Warfarin	30 mg	300 mg once daily for 12 days	(R)-warfarin	1.01 (0.96; 1.06)	1.03 (0.94; 1.13)	No dosage adjustment required for warfarin
			(S)-warfarin	1.06 (1.00; 1.12)	1.01 (0.90; 1.13)	

¹ Single dose unless otherwise noted

² AUC_{inf} for drugs given as a single dose and AUC_{24h} for drugs given as multiple doses.

³ AUC_{0-12h}

Pharmacodynamic Interactions

Diuretics: INVOKANA[®] is not recommended for use in patients receiving loop diuretics. INVOKANA[®] may add to the effect of diuretics and may increase the risk of hypovolemia and hypotension (see **WARNINGS AND PRECAUTIONS and DOSAGE AND ADMINISTRATION**).

Drug-Food Interactions

Interactions with food have not been established.

Drug-Herb Interactions

St John's Wort (*Hypericum perforatum*) is a CYP3A4 inducer and co-administration with INVOKANA[®] may result in loss of efficacy or reduced clinical response. Dosage adjustment may be required (see **DOSAGE AND ADMINISTRATION**).

Drug-Laboratory Interactions

Due to its mechanism of action, patients taking INVOKANA[®] will test positive for glucose in their urine.

Increases in urinary glucose excretion with INVOKANA[®] can falsely lower 1,5-anhydroglucitol (1,5 AG) levels and make measurements of 1,5 AG unreliable in assessing glycemic control. Therefore, 1,5-AG assays should not be used for assessment of glycemic control in patients on canagliflozin. For further detail, it may be advisable to contact the specific manufacturer of the 1,5-AG assay.

Drug-Lifestyle Interactions

Effects on Ability to Drive and Use Machines: The effect of canagliflozin on the ability to drive and use machines has not been examined. However, patients should be alerted to the elevated risk of adverse reactions related to reduced intravascular volume, such as postural dizziness, and to the risk of hypoglycemia when INVOKANA[®] is used as add-on therapy with insulin or an insulin secretagogue (see **WARNINGS AND PRECAUTIONS, ADVERSE REACTIONS and DOSAGE AND ADMINISTRATION**).

DOSAGE AND ADMINISTRATION

Prior to Initiation of INVOKANA[®]

Assess renal function before initiating INVOKANA[®] and periodically thereafter (see **WARNINGS AND PRECAUTIONS**). In patients with volume depletion not previously treated with canagliflozin, normalize volume status before initiating INVOKANA[®] (see **WARNINGS**

AND PRECAUTIONS).

Recommended Dosage and Dose Adjustments

See [Table 16](#) for dosage recommendations based on estimated glomerular filtration rate (eGFR).

Table 16: Recommended Dosage

Estimated glomerular filtration rate eGFR (mL/min/1.73 m²)	Recommended Dosage
eGFR ≥ 60	100 mg orally once daily, taken before the first meal of the day. Dose can be increased to 300 mg once daily for additional glycemic control
eGFR 30 to < 60	100 mg once daily
On dialysis	Contraindicated (see CONTRAINDICATIONS)

There are insufficient data to support dosing recommendations for initiation of therapy in patients with an eGFR < 30 mL/min/1.73 m². In patients already initiated on therapy who meet the criterion of an eGFR < 30 mL/min/1.73 m² with albuminuria >33.9 mg/mmol, therapy can be continued at 100 mg once daily.

Dosing Considerations

Concomitant Use with Insulin or an Insulin Secretagogue (e.g., Sulfonylurea): When INVOKANA[®] is used as add-on therapy with insulin or an insulin secretagogue (e.g., sulfonylurea), a lower dose of insulin or the insulin secretagogue may be considered to reduce the risk of hypoglycemia (see **WARNINGS AND PRECAUTIONS** and **ADVERSE REACTIONS**).

Concomitant Use with UDP-Glucuronosyl Transferase (UGT) Enzyme Inducers: If an inducer of UGTs and drug transport systems (e.g., rifampin, phenytoin, barbituates, phenobarbital, ritonavir, carbamazepine, efavirenz, St John's wort [*Hypericum perforatum*]) is co-administered with INVOKANA[®], monitor A1C in patients receiving INVOKANA[®] 100 mg once daily and consider increasing the dose to 300 mg once daily in patients currently tolerating INVOKANA[®] 100 mg once daily with an eGFR ≥60 mL/min/1.73 m² or CrCl ≥60 mL/min and require additional glycemic control. Consider another antihyperglycemic agent in patients with an eGFR of 45 to less than 60 mL/min/1.73 m² receiving concurrent therapy with a UGT inducer.

Diuretics: INVOKANA[®] is not recommended for use in patients on loop diuretics.

Geriatrics (≥65 years of age): Renal function and risk of volume depletion should be taken into account. For those patients who are tolerating INVOKANA[®] 100 mg and who need more glycemic control, the dose can be increased to INVOKANA[®] 300 mg (see **WARNINGS AND PRECAUTIONS** and **ADVERSE REACTIONS**)

Pediatrics (<18 years of age): The safety and efficacy of INVOKANA[®] have not been

established in pediatric patients. Therefore, INVOKANA[®] should not be used in this population.

Hepatic Impairment: INVOKANA[®] has not been studied in patients with severe hepatic impairment and is therefore not recommended for use in this patient population. No dose adjustment is necessary in patients with mild or moderate hepatic impairment.

INVOKANA[®] (canagliflozin) should be taken orally once a day, preferably before the first meal of the day, due to the potential to reduce postprandial plasma glucose excursions through delayed intestinal glucose absorption. However, INVOKANA[®] may be taken with or without food. Tablets are to be swallowed whole.

Missed Dose

If a dose of INVOKANA[®] is missed, the patient should be advised to take one dose as soon as they remember and the next dose at the usual time. A double dose of INVOKANA[®] should not be taken on the same day.

OVERDOSAGE

For management of a suspected drug overdose, contact your regional Poison Control Centre.

In the event of an overdose, contact the Poison Control Centre. It is also reasonable to employ the usual supportive measures, e.g., remove unabsorbed material from the gastrointestinal tract, employ clinical monitoring, and institute supportive treatment as dictated by the patient's clinical status. Canagliflozin was negligibly removed during a 4-hour hemodialysis session. Canagliflozin is not expected to be dialyzable by peritoneal dialysis.

ACTION AND CLINICAL PHARMACOLOGY

Mechanism of Action

Sodium-glucose co-transporter 2 (SGLT2), expressed in the proximal renal tubules, is responsible for the majority of the reabsorption of filtered glucose from the tubular lumen. Patients with diabetes have been shown to have elevated renal glucose reabsorption which may contribute to persistent elevated glucose concentrations. Canagliflozin is an orally-active inhibitor of SGLT2. By inhibiting SGLT2, canagliflozin reduces reabsorption of filtered glucose and lowers the renal threshold for glucose (RT_G), and thereby increases urinary glucose excretion, which decreases elevated plasma glucose concentrations by an insulin-independent mechanism in patients with type 2 diabetes. The increased urinary glucose excretion with SGLT2 inhibition also translates to an osmotic diuresis, with the diuretic effect leading to a reduction in systolic blood pressure; the increase in urinary glucose excretion results in a loss of calories and therefore a reduction in body weight, as demonstrated in studies of patients with type 2 diabetes.

Canagliflozin's action to increase UGE directly lowering plasma glucose is independent of insulin. Improvement in homeostasis model assessment for beta-cell function (HOMA beta-cell) and improved beta-cell insulin secretion response to a mixed-meal challenge has been observed in clinical studies with INVOKANA[®].

In Phase 3 studies, pre-meal administration of canagliflozin 300 mg provided a greater reduction in post-meal glucose excursion than observed with the 100 mg dose. This effect at the 300 mg dose of canagliflozin may, in part, be due to local inhibition of intestinal SGLT1 (an important intestinal glucose co-transporter) related to transient high concentrations of canagliflozin in the intestinal lumen prior to drug absorption (canagliflozin is a low potency inhibitor of SGLT1). Studies have shown no glucose malabsorption with canagliflozin.

Pharmacodynamics

Following single and multiple oral doses of canagliflozin to patients with type 2 diabetes, dose-dependent decreases in RT_G and increases in urinary glucose excretion were observed. From a starting value of RT_G of approximately 13 mmol/L, maximal suppression of 24-hour mean RT_G was seen with the 300 mg daily dose to approximately 4 to 5 mmol/L in patients with type 2 diabetes in Phase 1 studies (see model in [Figure 3](#), suggesting a low risk for treatment-induced hypoglycemia. The reductions in RT_G led to increased UGE in subjects with type 2 diabetes treated with either 100 mg or 300 mg of canagliflozin ranging from 77 to 119 g/day across the Phase 1 studies; the UGE observed translates to a loss of 308 to 476 kcal/day. The reductions in RT_G and increases in UGE were sustained over a 26-week dosing period in patients with type 2 diabetes. Moderate increases (generally <400-500 mL) in daily urine volume were seen that attenuated over several days of dosing. Urinary uric acid excretion was transiently increased by canagliflozin (increased by 19% compared to baseline on day 1 and then attenuating to 6% on day 2 and 1% on day 13). This was accompanied by a sustained reduction in serum uric acid concentration of approximately 20%.

Figure 3: Predicted (PK/PD Modelled) 24-Hour Profile for RT_G in Subjects with Type 2 Diabetes Treated with Canagliflozin 100 mg and 300 mg

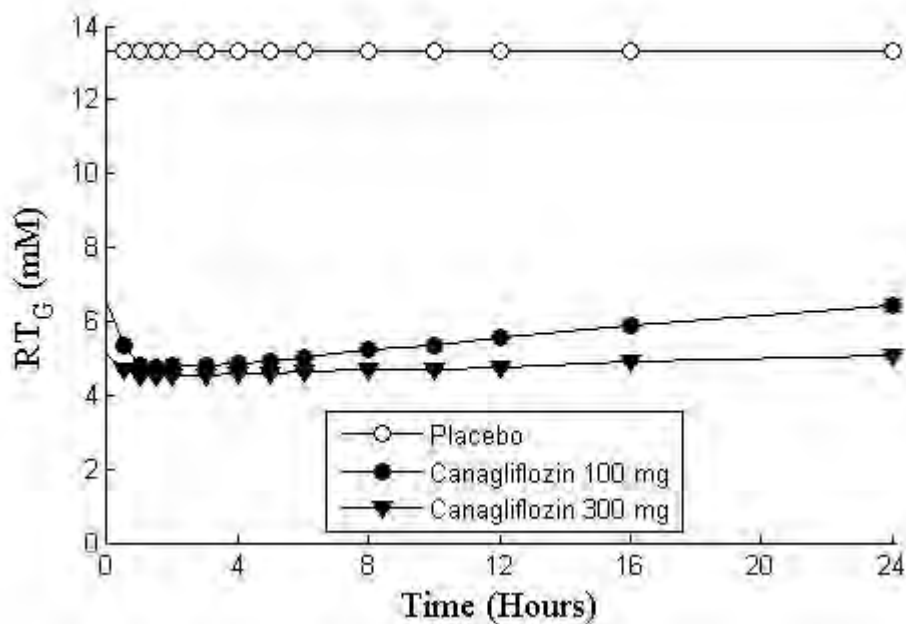

In a single-dose study in patients with type 2 diabetes, treatment with 300 mg before a mixed meal delayed intestinal glucose absorption and reduced postprandial glucose through both renal and non-renal mechanisms.

Cardiac electrophysiology

In a randomized, double-blind, placebo-controlled, active-comparator, 4-way crossover study, 60 healthy subjects were administered a single oral dose of canagliflozin 300 mg, canagliflozin 1200 mg (4 times the maximum recommended dose), moxifloxacin, and placebo. No meaningful changes in QT_c interval were observed with either the recommended dose of 300 mg or the 1200 mg dose. At the 1200 mg dose, peak canagliflozin plasma concentrations were approximately 1.4 times the steady-state peak concentrations following a 300 mg once-daily dose.

Pharmacokinetics

Pharmacokinetics of INVOKANA[®] were comparable between healthy volunteers and type 2 diabetic patients based on clinical trials and population pharmacokinetic data. After single-dose oral administration of 100 mg and 300 mg in healthy subjects, canagliflozin was rapidly absorbed, with peak plasma concentrations (median T_{max}) occurring 1 to 2 hours post-dose. Plasma C_{max} and AUC of canagliflozin increased in a dose-proportional manner from 50 mg to 300 mg. The apparent terminal half-life (t_{1/2}) (expressed as mean ± standard deviation) was 10.6 ± 2.13 hours to 13.1 ± 3.28 hours for the 100 mg and 300 mg doses, respectively. Steady-state was reached after 4 to 5 days of once-daily dosing with canagliflozin 100 mg to 300 mg. Canagliflozin does not exhibit time-dependent pharmacokinetics, and accumulated in plasma up to 36% following multiple doses of 100 mg and 300 mg.

Table 17: Summary of Canagliflozin’s Pharmacokinetic Parameters in Healthy Subjects and T2DM Patients at Steady State

	N	C _{max} (SD) (ng/mL)	t _{1/2} (h)	AUC _{24h} (SD) (ng.h/mL)	Cl/F	Vd/F
Healthy Volunteers^a						
100 mg multiple oral doses qd	9	1,118 (143)	13.3 (4.8)	6,056 (959)	16.4 (2.16)	304 (79.7)
300 mg multiple oral doses qd	9	3,379 (728)	13.5 (3.2)	19,252 (5,348)	16.4 (3.60)	319 (104)
T2DM Patients^b						
100 mg multiple oral doses qd	8	1,227 (481)	13.7 (2.1)	8,225 (1,947)	13.0 (4.43)	250 (50.7)
300 mg multiple oral doses qd	10	4,678 (1,685)	14.9 (4.8)	30,995 (11,146)	11.3 (5.21)	226 (89.4)

^a From Study DIA1030

^b From Study DIA1023

Absorption: The mean absolute oral bioavailability of canagliflozin is approximately 65%. Co-administration of a high-fat meal with canagliflozin had no effect on the pharmacokinetics of canagliflozin; therefore, INVOKANA[®] may be taken with or without food. However, based on the potential to reduce postprandial plasma glucose excursions due to delayed intestinal glucose absorption, it is recommended that INVOKANA[®] preferably be taken before the first meal of the day (see **DOSAGE AND ADMINISTRATION**).

Distribution: The mean steady-state volume of distribution of canagliflozin following a single intravenous infusion in healthy subjects was 83.5 L, suggesting extensive tissue distribution. Canagliflozin is extensively bound to proteins in plasma (99%), mainly to albumin. Protein binding is independent of canagliflozin plasma concentrations. Plasma protein binding is not meaningfully altered in patients with renal or hepatic impairment.

Metabolism: *O*-glucuronidation is the major metabolic elimination pathway for canagliflozin, which is mainly glucuronidated by UGT1A9 and UGT2B4 to two inactive *O*-glucuronide metabolites. CYP3A4-mediated (oxidative) metabolism of canagliflozin is minimal (approximately 7%) in humans.

Excretion: Following administration of a single oral [¹⁴C] canagliflozin dose to healthy subjects, 41.5%, 7.0%, and 3.2% of the administered radioactive dose was recovered in faeces as canagliflozin, a hydroxylated metabolite, and an *O*-glucuronide metabolite, respectively. Enterohepatic circulation of canagliflozin was negligible.

Approximately 33% of the administered radioactive dose was excreted in urine, mainly as *O*-glucuronide metabolites (30.5%). Less than 1% of the dose was excreted as unchanged canagliflozin in urine. Renal clearance for the 100 mg and 300 mg doses ranged from 1.30 to 1.55 mL/min.

Canagliflozin is a low-clearance drug, with a mean systemic clearance of approximately 192 mL/min in healthy subjects following intravenous administration.

Special Populations and Conditions

Pediatrics: Based on the data submitted and reviewed by Health Canada, the safety and efficacy of canagliflozin in pediatric patients <18 years of age have not been established; therefore, Health Canada has not authorized an indication for pediatric use (see **WARNING AND PRECAUTIONS, Pediatrics**).

An open-label, sequential, multiple-dose, multicentre pediatric Phase 1 study examined the pharmacokinetics and pharmacodynamics of canagliflozin in children and adolescents ≥ 11 to < 18 years of age (mean age 14.6 years) with type 2 diabetes mellitus who were on a stable dose of metformin. The mean body weight was 107.15 kg (range: 48.5 to 168.6 kg).

The patients were treated with canagliflozin once-daily 100 mg or 300 mg for 14 days.

Table 18 Mean (SD) Plasma Canagliflozin Pharmacokinetic Parameters on Day 14

Parameters	Canagliflozin 100 mg QD (N=8) Mean (Std. Dev.)	Canagliflozin 300 mg QD (N=9) Mean (Std. Dev.)
C _{max} (ng/mL)	951 (429)	3,260 (1,330)
AUC (h*ng/mL)	6,190 (1,770)	28,392 (12,412)
t _{1/2} (h)	11.3 (2.5)	15.2 (6.9)
CL _{ss} /F (L/h)	17.5 (5.78)	12.3 (6.90)

Geriatrics (≥ 65 years of age): Age had no clinically meaningful effect on the pharmacokinetics of canagliflozin based on a population pharmacokinetic analysis. However, patients 65 years and older had a higher incidence of adverse reactions related to reduced intravascular volume with INVOKANA[®] (see **WARNINGS AND PRECAUTIONS, ADVERSE REACTIONS and DOSAGE AND ADMINISTRATION**).

Body weight: For subjects with body weight <78.2 kg, the dose normalized exposures of INVOKANA[®] increased by 33%, based on population pharmacokinetic analysis. These increases in exposures are not clinically meaningful and hence no dosage adjustment of INVOKANA[®] is necessary based on body weight.

Gender: Dose normalized exposures of INVOKANA[®] in females were 22% higher than males, based on population pharmacokinetic analysis. These increases in exposures are not clinically meaningful and hence no dosage adjustment of INVOKANA[®] is necessary based on gender.

Race: Dose normalized exposures of INVOKANA[®] were comparable in white and non-white subjects, Blacks, Asians, and other races. A population PK analysis of canagliflozin in 942 white subjects and 674 non-white subjects showed no significant impact of race on canagliflozin PK and hence no dosage adjustment of INVOKANA[®] is necessary based on race.

Hepatic Insufficiency: Relative to subjects with normal hepatic function, the geometric mean ratios for C_{max} and AUC_∞ of canagliflozin were 107% and 110%, respectively, in subjects with

Child-Pugh class A (mild hepatic impairment) and 96% and 111%, respectively, in subjects with Child-Pugh class B (moderate hepatic impairment) following administration of a single 300 mg dose of canagliflozin.

These differences are not considered to be clinically meaningful. No dose adjustment is necessary in patients with mild or moderate hepatic impairment. There is no clinical experience in patients with Child-Pugh class C (severe) hepatic impairment and, therefore, INVOKANA[®] is not recommended for use in this patient population.

Renal Insufficiency: A single-dose, open-label study evaluated the pharmacokinetics of canagliflozin 200 mg in subjects with varying degrees of renal impairment, classified using the Modification of Diet in Renal Disease (MDRD)-eGFR formula, compared to healthy subjects. The study included 3 subjects with normal renal function (eGFR ≥ 90 mL/min/1.73 m²), 10 subjects with mild renal impairment (eGFR 60 to < 90 mL/min/1.73 m²), 9 subjects with moderate renal impairment (eGFR 30 to < 60 mL/min/1.73 m²), and 10 subjects with severe renal impairment (eGFR 15 to < 30 mL/min/1.73 m²) as well as 8 subjects with end stage renal disease (ESRD) on hemodialysis.

The C_{max} of canagliflozin was moderately increased by 13%, 29%, and 29% in subjects with mild, moderate, and severe renal failure, respectively, but not in subjects on hemodialysis. Compared to healthy subjects, plasma AUC of canagliflozin was increased by approximately 17%, 63%, and 50% in subjects with mild, moderate, and severe renal impairment, respectively, but was similar for ESRD subjects and healthy subjects. Increases in canagliflozin AUC of this magnitude are not considered clinically relevant, however, the pharmacodynamic response to canagliflozin declines with increasing severity of renal impairment (see **CONTRAINDICATIONS** and **WARNINGS AND PRECAUTIONS**). Canagliflozin was negligibly removed by hemodialysis.

Genetic polymorphism: Both UGT1A9 and UGT2B4 are subject to genetic polymorphism. In a pooled analysis of clinical data, increases in canagliflozin AUC of 26% were observed in UGT1A9*1/*3 carriers and 18% in UGT2B4*2/*2 carriers. These increases in canagliflozin exposure are not expected to be clinically relevant and no dosage adjustment is necessary based on UGT1A9 and UGT2B4 genetic polymorphisms. The effect of being homozygote (UGT1A9*3/*3, frequency $< 0.1\%$) is probably more marked, but has not been investigated.

STORAGE AND STABILITY

INVOKANA® tablets should be stored at 15-30°C.

SPECIAL HANDLING INSTRUCTIONS

Keep INVOKANA® out of the sight and reach of children.

DOSAGE FORMS, COMPOSITION AND PACKAGING

INVOKANA® is supplied as film-coated, immediate-release tablets for oral administration. Each tablet strength contains canagliflozin drug substance as the hemihydrate equivalent to 100- and 300-mg doses of anhydrous canagliflozin, respectively. Both tablet strengths are supplied as blisters in cartons of 30 or 90.

100 mg tablets: Yellow, capsule-shaped, film-coated, tablets with “CFZ” on one side and “100” on the other side.

300 mg tablets: White, capsule-shaped, film-coated, tablets with “CFZ” on one side and “300” on the other side.

Composition

Each tablet contains the following non-medicinal ingredients:

Core Tablet: croscarmellose sodium, hydroxypropyl cellulose, lactose anhydrous, magnesium stearate, and microcrystalline cellulose.

Film Coat: iron oxide yellow (100 mg tablet only), Macrogol (polyethylene glycol), polyvinyl alcohol, talc, and titanium dioxide.

PART II: SCIENTIFIC INFORMATION

PHARMACEUTICAL INFORMATION

Drug Substance

Common name: canagliflozin

Chemical name: (1S)-1,5-anhydro-1-[3-[[5-(4-fluorophenyl)-2-thienyl]methyl]-4-methylphenyl]-D-glucitol hemihydrate

Molecular formula: $C_{24}H_{25}FO_5S \cdot 1/2 H_2O$

Molecular mass:

- Hemihydrate: 453.53
- Anhydrous: 444.52

Structural formula:

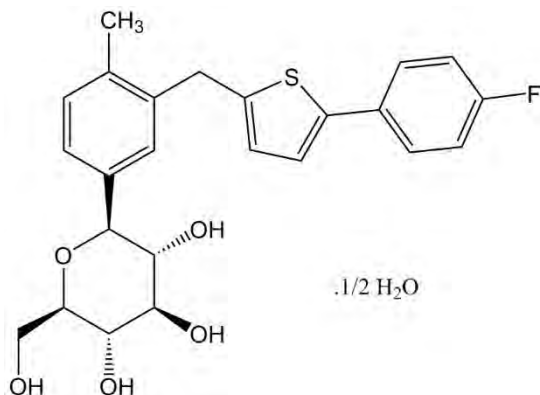

Physicochemical properties: Canagliflozin is practically insoluble in aqueous media from pH 1.1 to 12.9. There is no detectable pK_a value for this substance.

CLINICAL TRIALS

INVOKANA[®] was studied as monotherapy in one placebo-controlled study of 26 weeks duration, which included an active-treatment substudy in patients with more severe hyperglycemia (HbA1C [A1C] >10 and ≤12%). Six placebo- or active-controlled studies investigated INVOKANA[®] as add-on therapy with other antihyperglycemic agents: two studies with metformin (26 and 52 weeks); two studies with metformin and sulfonylurea (26 and 52 weeks), one study with metformin and pioglitazone (26 weeks) and one study with metformin and sitagliptin (26 weeks). Two placebo-controlled studies investigated the use of INVOKANA[®], added onto the current diabetes treatment regimen, one in older patients, and one in patients with moderate renal impairment. A cardiovascular study has been conducted in patients with type 2 diabetes; safety analyses were conducted that investigated INVOKANA[®] as add-on therapy with a sulfonylurea and with insulin. A long-term renal outcomes study has been conducted in patients with type 2 diabetes and diabetic nephropathy on a background of standard of care including maximally tolerated labelled ACEi and ARB treatments.

Study Demographics and Trial Design

Table 19: Summary of Patient Demographics for Clinical Trials in Specific Indication

Study #	Trial design	Dosage, route of administration and duration	Study subjects (n=number)	Mean age (Range)	Gender (% F/M)
Monotherapy					
DIA3005	Randomized, double-blind, placebo-controlled, parallel-group, multicentre	INVOKANA [®] 100 or 300 mg/day or Placebo 26-week	Total: 584 INVOKANA [®] 100 mg: 195 INVOKANA [®] 300 mg: 197 Placebo: 192	55.4 (24-79)	55.8/44.2
Add-on Therapy with Metformin (≥ 1500 mg/day)					
DIA3006	Randomized, double-blind, active-controlled, parallel-group, multicentre	INVOKANA [®] 100 or 300 mg/day or Sitagliptin 100 mg/day or Placebo 26-week	Total: 1284 INVOKANA [®] 100 mg: 368 INVOKANA [®] 300 mg: 367 Sitagliptin 100 mg: 366 Placebo: 183	55.4 (21-79)	52.9/47.1
DIA3009	Randomized, double-blind, active-controlled, parallel-group, multicentre	INVOKANA [®] 100 or 300 mg/day or Glimepiride 1- 8 mg (titration protocol) 52-week	Total: 1450 INVOKANA [®] 100 mg: 483 INVOKANA [®] 300 mg: 485 Glimepiride: 482	56.2 (22-80)	47.9/52.1

Study #	Trial design	Dosage, route of administration and duration	Study subjects (n=number)	Mean age (Range)	Gender (% F/M)
Add-on Therapy with a Sulfonylurea (stable dose)					
DIA3008 SU Substudy	Randomized, double-blind, placebo-controlled, parallel-group, multicentre	INVOKANA [®] 100 or 300 mg/day or Placebo 18-week	Total: 127 INVOKANA [®] 100 mg: 42 INVOKANA [®] 300 mg: 40 Placebo: 45	64.8 (44-82)	43.3/56.7
Add-on Therapy with Metformin (≥ 1500 mg/day) and a Sulfonylurea (stable dose)					
DIA3002	Randomized, double-blind, placebo-controlled, parallel-group, multicentre	INVOKANA [®] 100 or 300 mg/day or Placebo 26-week	Total: 469 INVOKANA [®] 100 mg: 157 INVOKANA [®] 300 mg: 156 Placebo: 156	56.8 (27-79)	49.0/51.0
DIA3015	Randomized, double-blind, active-controlled, parallel-group, multicentre	INVOKANA [®] 300 mg/day or Sitagliptin 100 mg/day or Placebo 52-week	Total: 755 INVOKANA [®] 300 mg: 377 Sitagliptin 100 mg: 378	56.7 (21-91)	44.1/55.9
Add-on Therapy with Metformin (≥ 1500 mg/day) and Pioglitazone (30 or 45 mg/day)					
DIA3012	Randomized, double-blind, placebo-controlled, parallel-group, multicentre	INVOKANA [®] 100 or 300 mg/day or Placebo 26-week	Total: 342 INVOKANA [®] 100 mg: 113 INVOKANA [®] 300 mg: 114 Placebo: 115	57.4 (27-78)	36.8/63.2
Add-on with Insulin (≥20 units/day) as monotherapy or in combination with other AHA(s) ¹					
DIA3008 Insulin Substudy	Randomized, double-blind, placebo-controlled, parallel-group, multicentre	INVOKANA [®] 100 or 300 mg/day or Placebo 18-week	Total: 1718 INVOKANA [®] 100 mg: 566 INVOKANA [®] 300 mg: 587 Placebo: 565	62.8 (32-85)	33.5/66.5
Add-on Therapy with Metformin (≥ 1500 mg/day) and Sitagliptin (100 mg/day)					
DIA4004	Randomized, double-blind, placebo-controlled, parallel-group, multicentre	INVOKANA [®] 100 up-titrated to 300 mg/day at Week 6 or Placebo 26-week	Total: 213 INVOKANA [®] :107 ² Placebo: 106	57.4 (23-76)	43.2/56.8

Study #	Trial design	Dosage, route of administration and duration	Study subjects (n=number)	Mean age (Range)	Gender (% F/M)
Cardiovascular					
DIA3008	Randomized, double-blind, placebo-controlled, parallel-group, Multicentre	INVOKANA [®] 100 or 300 mg/day or Placebo mean 223 weeks exposure to study drug	Total: 4330 INVOKANA [®] 100 mg: 1445 INVOKANA [®] 300 mg: 1443 Placebo: 1442	62.4 (32-87)	33.9/66.1
DIA4003	Randomized, double-blind, placebo-controlled, parallel-group, Multicentre	INVOKANA [®] 100 up-titrated to 300 mg/day at week 13 or later at investigators' discretion mean 94 weeks exposure to study drug	Total: 5813 INVOKANA [®] 100 mg up titrated: 2907 Placebo: 2906	64 (30-90)	37.2/62.8
Renal					
DNE3001	Randomized, double-blind, placebo-controlled, parallel-group, Multicentre	INVOKANA [®] 100 mg or Placebo mean 115 weeks exposure to study drug	Total: 4401 INVOKANA [®] 100 mg: 2202 Placebo: 2199	63 (30-89)	33.9/66.1
Special Populations					
DIA3010 (Older Adults)	Randomized, double-blind, placebo-controlled, parallel-group, Multicentre	INVOKANA [®] 100 or 300 mg/day + any AHA ¹ or Placebo + any AHA ¹ 26-week	Total: 714 INVOKANA [®] 100 mg: 241 INVOKANA [®] 300 mg: 236 Placebo: 237	63.6 (55-80)	44.5/55.5
DIA3004 (Renal Impairment)	Randomized, double-blind, placebo-controlled, parallel-group, Multicentre	INVOKANA [®] 100 or 300 mg/day + any AHA ¹ or Placebo + any AHA ¹ 26-week	Total: 269 INVOKANA [®] 100 mg: 90 INVOKANA [®] 300 mg: 89 Placebo: 90	68.5 (39-96)	39.4/60.6

¹ AHA = antihyperglycemic agent

² 10 subjects did not up-titrate to canagliflozin 300 mg at Week 6, 3 of whom completed Week 26

A total of 10,285 patients with type 2 diabetes were randomized in nine double-blind, controlled clinical efficacy and safety studies conducted to evaluate the effects of INVOKANA[®] on glycemic control. The racial distribution was 72% White, 16% Asian, 4% Black, and 8% other

groups. Approximately 16% of patients were Hispanic. Approximately 58% of patients were male. Patients had an overall mean age of 59.6 years (range 21 to 96 years), with 3082 patients 65 years of age and older and 510 patients 75 years of age and older. One study was conducted in patients with moderate renal impairment with an eGFR 30 to <50 mL/min/1.73 m² (N=269) and three other studies included patients with moderate renal impairment (eGFR 30 to <60 mL/min/1.73 m²) (N=816).

Study Results

In patients with type 2 diabetes, treatment with INVOKANA[®] produced statistically significant improvements in A1C, fasting plasma glucose (FPG), 2-hour postprandial glucose (PPG), and body weight, compared to placebo. INVOKANA[®] was effective in reducing A1C in a broad range of patients regardless of disease duration and concomitant use of antihyperglycemic agents. The durability of these reductions in A1C was demonstrated in two Phase 3 studies, with minimal attenuation of the glycemic response to INVOKANA[®] over 52 weeks, in contrast to the deterioration of the glycemic response observed with comparators.

Statistically significant improvements in glycemic control relative to placebo were observed with INVOKANA[®] when given as monotherapy, as-add on therapy with metformin or a sulfonylurea, metformin and a sulfonylurea, metformin and pioglitazone, metformin and sitagliptin or as add-on therapy with insulin (with or without other antihyperglycemic agents).

In addition, significant improvements in A1C were observed with INVOKANA[®] in subjects with moderate renal impairment (eGFR 30 to <60 mL/min/1.73 m²) and in older patients. Reductions in A1C were observed across subgroups including age, gender, race, baseline body mass index (BMI), and baseline beta-cell function. Greater reductions in A1C relative to placebo were observed in patients with higher baseline A1C or eGFR values.

Monotherapy (Study DIA3005)

A total of 584 patients with inadequate glycemic control (A1C of ≥7% to ≤10%) on diet and exercise participated in a randomized, double-blind, placebo-controlled, parallel-group, 3-arm, multicentre clinical study to evaluate the efficacy of INVOKANA[®] over 26 weeks. The mean age was 55 years, 44% of patients were men, and the mean baseline eGFR was 87 mL/min/1.73 m². Patients taking other antihyperglycemic agents (N=281) discontinued the agent and underwent a drug washout period of approximately 8 weeks immediately followed by a 2-week, single-blind, placebo run-in period. Patients not taking an oral antihyperglycemic agent (off therapy for at least 8 weeks) (N=303) with inadequate glycemic control entered a 2-week, single-blind, placebo run-in period. Patients were randomized to take INVOKANA[®] 100 mg, INVOKANA[®] 300 mg, or placebo, administered once daily. As shown in [Table 20](#), statistically significant (p<0.001) reductions in A1C, FPG, PPG, and body weight relative to placebo were observed. In addition, a greater percentage of patients achieved an A1C <7.0% compared to placebo. Statistically significant (p<0.001) reductions in systolic blood pressure were observed with INVOKANA[®] 100 mg and 300 mg relative to placebo of -3.7 mmHg and -5.4 mmHg, respectively.

Patients who were not eligible for inclusion in the main placebo-controlled study due to more severe hyperglycemia (A1C >10 and ≤ 12%) participated in a separate active-treatment substudy (N=91) and were treated with either INVOKANA® 100 mg or INVOKANA® 300 mg (see Table 20).

Table 20: Results from 26-Week Placebo-Controlled Clinical Study with INVOKANA® as Monotherapy¹

Efficacy Parameter	INVOKANA® 100 mg (N=195)	INVOKANA® 300 mg (N=197)	Placebo (N=192)
A1C (%)			
Baseline (mean)	8.06	8.01	7.97
Change from baseline (adjusted mean)	-0.77	-1.03	0.14
Difference from placebo (adjusted mean) (95% CI)	-0.91 ² (-1.09; -0.73)	-1.16 ² (-1.34; -0.99)	N/A ³
Percent of Patients Achieving A1C <7%	44.5 ²	62.4 ²	20.6
Fasting Plasma Glucose (mmol/L)			
Baseline (mean)	9.57	9.57	9.20
Change from baseline (adjusted mean)	-1.51	-1.94	0.46
Difference from placebo (adjusted mean) (95% CI)	-1.97 ² (-2.34; -1.60)	-2.41 ² (-2.78; -2.03)	N/A ³
2-hour Postprandial Glucose (mmol/L)			
Baseline (mean)	13.87	14.10	12.74
Change from baseline (adjusted mean)	-2.38	-3.27	0.29
Difference from placebo (adjusted mean) (95% CI)	-2.67 ² (-3.28; -2.05)	-3.55 ² (-4.17; -2.94)	N/A ³
Body Weight			
Baseline (mean) in kg	85.9	86.9	87.5
% change from baseline (adjusted mean)	-2.8	-3.9	-0.6
Difference from placebo (adjusted mean) (95% CI)	-2.2 ² (-2.9; -1.6)	-3.3 ² (-4.0; -2.6)	N/A ³
Separate Active-Treatment Substudy of Patients with High Baseline A1C Levels (>10 to ≤12%)			
Efficacy Parameter	INVOKANA® 100 mg (N=47)	INVOKANA® 300 mg (N=44)	
A1C (%)			
Baseline (mean)	10.59	10.62	
Change from baseline (adjusted mean)	-2.13	-2.56	
Percent of Patients Achieving A1C <7%	17.4	11.6	
Fasting Plasma Glucose (mmol/L)			
Baseline (mean)	13.18	13.50	
Change from baseline (adjusted mean)	-4.54	-4.79	
2-hour Postprandial Glucose (mmol/L)			
Baseline (mean)	18.34	19.68	
Change from baseline (adjusted mean)	-6.58	-6.98	
Body Weight			
Baseline (mean) in kg	83.2	81.6	
% change from baseline (adjusted mean)	-3.0	-3.8	

¹ Intent-to-treat population using last observation in study prior to glycemic rescue therapy

² p<0.001 compared to placebo

³ N/A = Not applicable

Add-on Therapy

Add-on Therapy with Metformin (Study DIA3006)

A total of 1284 patients with inadequate glycemic control (A1C of $\geq 7\%$ to $\leq 10.5\%$) on metformin monotherapy (2,000 mg/day or at least 1,500 mg/day if higher dose not tolerated) participated in a randomized, double-blind, placebo- and active-controlled, parallel-group, 4-arm, multicentre clinical study to evaluate the efficacy of INVOKANA[®] as add-on therapy with metformin over 26 weeks. The mean age was 55 years, 47% of patients were men, and the mean baseline eGFR was 89 mL/min/1.73 m². Patients already on metformin (N=1009) at screening with inadequate glycemic control completed a 2-week, single-blind, placebo run-in period. Other patients on metformin and another oral agent or a lower than required dose of metformin (N=275) were switched to a regimen of metformin monotherapy. After at least 8 weeks on a stable dose of metformin monotherapy, patients entered a 2-week, single-blind, placebo run-in period. Patients were randomized to the addition of INVOKANA[®] 100 mg, INVOKANA[®] 300 mg, sitagliptin 100 mg, or placebo, administered once daily.

As shown in [Table 21](#), statistically significant ($p < 0.001$) reductions in A1C, FPG, PPG, and body weight relative to placebo were observed. In addition, a greater percentage of patients achieved an A1C $< 7.0\%$ compared to placebo. Statistically significant ($p < 0.001$) reductions in systolic blood pressure were observed with INVOKANA[®] 100 mg and 300 mg relative to placebo of -5.4 mmHg and -6.6 mmHg, respectively.

Table 21: Results from Placebo-Controlled Clinical Study of INVOKANA® as Add-on Therapy with Metformin¹

Efficacy Parameter	INVOKANA® + Metformin 26 weeks		Placebo + Metformin (N=183)
	100 mg (N=368)	300 mg (N=367)	
A1C (%)			
Baseline (mean)	7.94	7.95	7.96
Change from baseline (adjusted mean)	-0.79	-0.94	-0.17
Difference from placebo (adjusted mean) (95% CI)	-0.62 ² (-0.76; -0.48)	-0.77 ² (-0.91; -0.64)	N/A ³
Percent of patients achieving A1C < 7%	45.5 ²	57.8 ²	29.8
Fasting Plasma Glucose (mmol/L)			
Baseline (mean)	9.36	9.59	9.12
Change from baseline (adjusted mean)	-1.52	-2.10	0.14
Difference from placebo (adjusted mean) (95% CI)	-1.65 ² (-1.99; -1.32)	-2.23 ² (-2.57; -1.90)	N/A ³
2-hour Postprandial Glucose (mmol/L)			
Baseline (mean)	14.30	14.54	13.81
Change from baseline (adjusted mean)	-2.66	-3.17	-0.55
Difference from placebo (adjusted mean) (95% CI)	-2.12 ² (-2.73; -1.51)	-2.62 ² (-3.24; -2.01)	N/A ³
Body Weight			
Baseline (mean) in kg	88.7	85.4	86.7
% change from baseline (adjusted mean)	-3.7	-4.2	-1.2
Difference from placebo (adjusted mean) (95% CI)	-2.5 ² (-3.1; -1.9)	-2.9 ² (-3.5; -2.3)	N/A ³

¹ Intent-to-treat population using last observation in study prior to glycemic rescue therapy

² p<0.001 compared to placebo

³ N/A = Not applicable

Active-Controlled Study versus Glimepiride as add-on therapy with Metformin (Study DIA3009)

A total of 1450 patients with inadequate glycemic control (A1C level of $\geq 7\%$ to $\leq 9.5\%$) on metformin monotherapy ($\geq 2,000$ mg/day or at least 1,500 mg/day if higher dose not tolerated) participated in a randomized, double-blind, active-controlled, parallel-group, 3-arm, multicentre clinical study to evaluate the efficacy of INVOKANA® as add-on therapy with metformin over 52 weeks. The mean age was 56 years, 52% of patients were men, and the mean baseline eGFR was 90 mL/min/1.73 m². Patients on metformin (N=928) at a stable protocol-specified dose entered a 2-week, single-blind, placebo run-in period. Other patients (N=522) entered a metformin dose titration and dose stabilization/antihyperglycemic agent washout period, immediately followed by the 2-week run-in period. Following the run-in period, patients with inadequate glycemic control were randomized to the addition of INVOKANA® 100 mg, INVOKANA® 300 mg, or glimepiride (titration allowed throughout the 52-week study to 6 to

8 mg), administered once daily.

As shown in Table 22 and Figure 4, after 52 weeks, treatment with INVOKANA® 100 mg provided similar reductions in A1C from baseline compared to glimepiride (with the upper bound of the 95% confidence interval around the between-group difference less than the pre-specified non-inferiority margin of 0.3%); INVOKANA® 300 mg provided a superior ($p < 0.05$) reduction from baseline in A1C compared to glimepiride (with the upper bound of the 95% confidence interval below 0). Statistically significant ($p < 0.001$) reductions in body weight were observed with INVOKANA® compared to glimepiride. Reductions in systolic blood pressure were observed with INVOKANA® 100 mg and 300 mg relative to glimepiride of -3.5 mmHg and -4.8 mmHg, respectively. The incidence of hypoglycemia with INVOKANA® was significantly lower ($p < 0.001$) compared to glimepiride.

Table 22: Results from 52-Week Clinical Study Comparing INVOKANA® to Glimepiride as Add-on Therapy with Metformin¹

Efficacy Parameter	INVOKANA® + Metformin 52 Weeks		Glimepiride (titrated) + Metformin (N=482)
	100 mg (N=483)	300 mg (N=485)	
A1C (%)			
Baseline (mean)	7.78	7.79	7.83
Change from baseline (adjusted mean)	-0.82	-0.93	-0.81
Difference from glimepiride (adjusted mean) (95% CI)	-0.01 ² (-0.11; 0.09)	-0.12 ² (-0.22; -0.02)	N/A ³
Percent of patients achieving A1C <7%	53.6	60.1	55.8
Fasting Plasma Glucose (mmol/L)			
Baseline (mean)	9.18	9.09	9.20
Change from baseline (adjusted mean)	-1.35	-1.52	-1.02
Difference from glimepiride (adjusted mean) (95% CI)	-0.33 (-0.56; -0.11)	-0.51 (-0.73; -0.28)	N/A ³
Body Weight			
Baseline (mean) in kg	86.8	86.6	86.6
% change from baseline (adjusted mean)	-4.2	-4.7	1.0
Difference from glimepiride (adjusted mean) (95% CI)	-5.2 ⁴ (-5.7; -4.7)	-5.7 ⁴ (-6.2; -5.1)	N/A ³

¹ Intent-to-treat population using last observation in study prior to glycemic rescue therapy

² Met pre-specified criteria for non-inferiority to glimepiride (with the upper bound of the 95% CI around the between-group difference less than the pre-specified non-inferiority margin of <0.3%). In a pre-specified assessment, the upper bound of the 95% CI for INVOKANA® 300 mg, but not for INVOKANA® 100 mg was < 0, indicating a superior ($p < 0.05$) reduction in A1C relative to glimepiride with INVOKANA® 300 mg.

³ N/A = Not applicable

⁴ $p < 0.001$

⁵ Includes only patients who had both baseline and post-baseline values

Figure 4: Mean Changes from Baseline for A1C (%) and Body Weight Over 52 Weeks in a Study Comparing INVOKANA® to Glimepiride as Add-on Therapy with Metformin

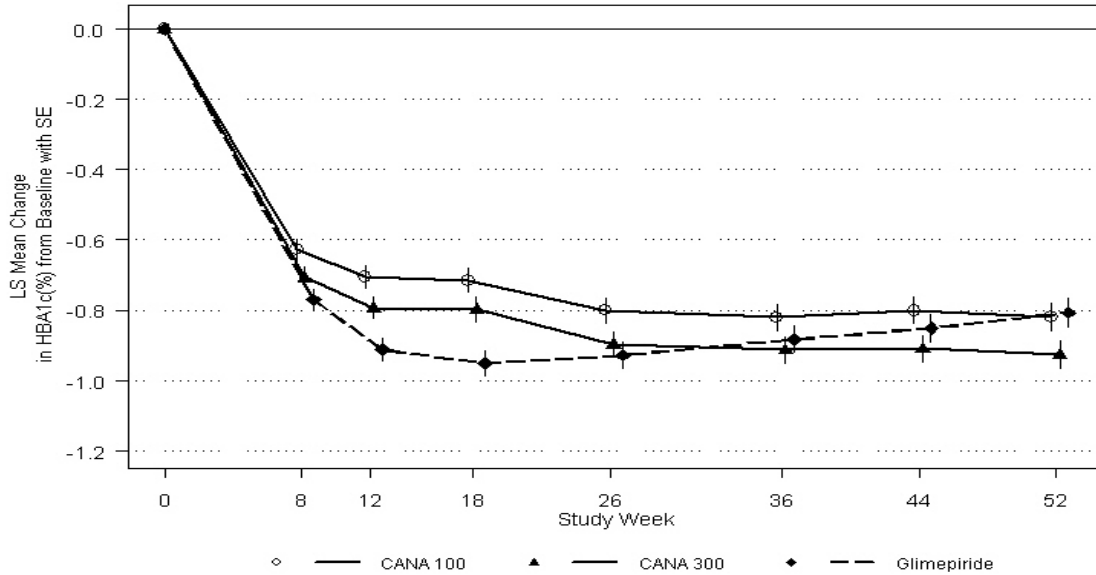

Note: LS Mean and SE in each post baseline visit are based on data with LOCF.

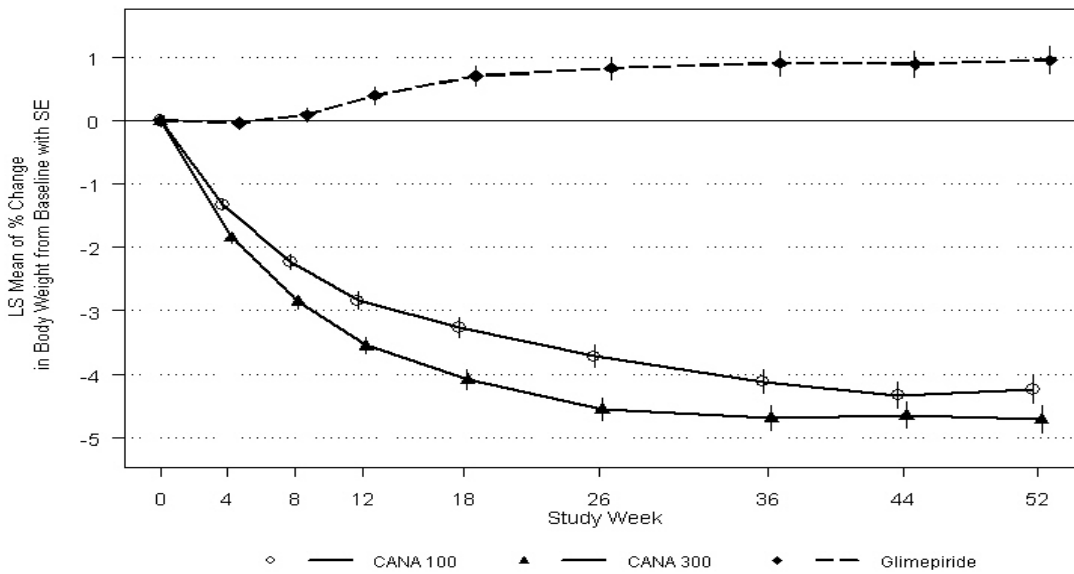

Note: LS Mean and SE in each post baseline visit are based on data with LOCF.

Add-on Therapy with Sulfonylurea (DIA3008 Substudy)

A total of 127 patients with inadequate glycemic control (A1C of $\geq 7\%$ to $\leq 10.5\%$) on sulfonylurea monotherapy participated in a randomized, double-blind, placebo-controlled, parallel-group, 3-arm, multicentre substudy of a cardiovascular outcomes study to evaluate the efficacy of INVOKANA[®] as add-on therapy with sulfonylurea over 18 weeks. The mean age was 65 years, 57% of patients were men, and the mean baseline eGFR was 69 mL/min/1.73 m². Patients on sulfonylurea monotherapy at a stable protocol-specified dose ($\geq 50\%$ maximal dose) for at least 10 weeks completed a 2-week, single-blind, placebo run-in period. After the run-in period, patients with inadequate glycemic control were randomized to the addition of INVOKANA[®] 100 mg, INVOKANA[®] 300 mg, or placebo, administered once daily.

As shown in Table 23, statistically significant ($p < 0.001$) reductions in A1C and FPG relative to placebo were observed at Week 18. In addition, a greater percentage of patients achieved an A1C $< 7.0\%$ compared to placebo. Patients treated with INVOKANA[®] 300 mg exhibited reductions in body weight compared to placebo. Reductions in systolic blood pressure were observed with INVOKANA[®] 100 mg and 300 mg relative to placebo of -0.1 mmHg and -1.8 mmHg, respectively. An increased incidence of hypoglycemia was observed in this study (see WARNINGS AND PRECAUTIONS and ADVERSE REACTIONS).

Table 23: Results from Placebo-Controlled Clinical Study of INVOKANA[®] as Add-on Therapy with a Sulfonylurea¹

Efficacy Parameter	INVOKANA [®] + Sulfonylurea 18 weeks		Placebo + Sulfonylurea (N=45)
	100 mg (N=42)	300 mg (N=40)	
A1C (%)			
Baseline (mean)	8.29	8.28	8.49
Change from baseline (adjusted mean)	-0.70	-0.79	0.04
Difference from placebo (adjusted mean) (95% CI)	-0.74 ² (-1.15; -0.33)	-0.83 ² (-1.24; -0.41)	N/A ⁴
Percent of patients achieving A1C $< 7\%$	25.0	33.3 ³	5.0
Fasting Plasma Glucose (mmol/L)			
Baseline (mean)	10.29	9.84	10.27
Change from baseline (adjusted mean)	-1.41	-2.00	0.67
Difference from placebo (adjusted mean) (95% CI)	-2.07 (-2.99; -1.15)	-2.66 ² (-3.59; -1.74)	N/A ⁴
Body Weight			
Baseline (mean) in kg	85.1	80.4	85.5
% change from baseline (adjusted mean)	-0.6	-2.0	-0.2
Difference from placebo (adjusted mean) (95% CI)	-0.4 (-1.8; 1.0)	-1.8 ³ (-3.2; -0.4)	N/A ⁴

¹ Intent-to-treat population using last observation in study prior to glycemic rescue therapy

² $p < 0.001$ compared to placebo

³ $p < 0.025$ compared to placebo

⁴ N/A = Not applicable

Add-on Therapy with Metformin and Sulfonylurea (Study DIA3002)

A total of 469 patients with inadequate glycemic control (A1C level of $\geq 7\%$ to $\leq 10.5\%$) on the combination of metformin (2,000 mg/day or at least 1,500 mg/day if higher dose not tolerated) and sulfonylurea (maximal or near-maximal effective dose) participated in a randomized, double-blind, placebo-controlled, parallel-group, 3-arm, multicentre clinical study to evaluate the efficacy of INVOKANA[®] as add-on therapy with metformin and sulfonylurea over 26 weeks. The mean age was 57 years, 51% of patients were men, and the mean baseline eGFR was 89 mL/min/1.73 m². Patients on near-maximal or maximal effective doses of metformin and sulfonylurea (N=372) entered a 2-week, single-blind, placebo run-in period. Other patients (N=97) entered a metformin and sulfonylurea dose titration and dose stabilization/antihyperglycemic agent washout period of up to 12 weeks, immediately followed by the 2-week run-in period. Following the run-in period, patients with inadequate glycemic control were randomized to the addition of INVOKANA[®] 100 mg, INVOKANA[®] 300 mg, or placebo administered once daily.

As shown in Table 24, statistically significant ($p < 0.001$) reductions in A1C, FPG, and body weight relative to placebo were observed. In addition, a greater percentage of patients achieved an A1C $< 7.0\%$ compared to placebo. Reductions in systolic blood pressure were observed with INVOKANA[®] 100 mg and 300 mg relative to placebo of -2.2 mmHg and -1.6 mmHg, respectively. An increased incidence of hypoglycemia was observed in this study (see WARNINGS AND PRECAUTIONS and ADVERSE REACTIONS).

Table 24: Results from 26-Week Placebo-Controlled Clinical Study of INVOKANA[®] as Add-on Therapy with Metformin and Sulfonylurea¹

Efficacy Parameter	INVOKANA [®] + Metformin and Sulfonylurea 26 Weeks		Placebo + Metformin and Sulfonylurea (N=156)
	100 mg (N=157)	300 mg (N=156)	
A1C (%)			
Baseline (mean)	8.13	8.13	8.12
Change from baseline (adjusted mean)	-0.85	-1.06	-0.13
Difference from placebo (adjusted mean) (95% CI)	-0.71 ² (-0.90; -0.52)	-0.92 ² (-1.11; -0.73)	N/A ³
Percent of patients achieving A1C $< 7\%$	43.2 ²	56.6 ²	18.0
Fasting Plasma Glucose (mmol/L)			
Baseline (mean)	9.60	9.34	9.42
Change from baseline (adjusted mean)	-1.01	-1.69	0.23
Difference from placebo (adjusted mean) (95% CI)	-1.24 ² (-1.75; -0.73)	-1.92 ² (-2.43; -1.41)	N/A ³
Body Weight			
Baseline (mean) in kg	93.5	93.5	90.8
% change from baseline (adjusted mean)	-2.1	-2.6	-0.7
Difference from placebo (adjusted mean) (95% CI)	-1.4 ² (-2.1; -0.7)	-2.0 ² (-2.7; -1.3)	N/A ³

¹ Intent-to-treat population using last observation in study prior to glycemic rescue therapy

² $p < 0.001$ compared to placebo

³ N/A = Not applicable or not measured in this study

Active-Controlled Study versus Sitagliptin as Add-on Therapy with Metformin and Sulfonylurea (Study DIA3015)

A total of 755 patients with inadequate glycemic control (A1C level of $\geq 7.0\%$ to $\leq 10.5\%$) on the combination of metformin (2,000 mg/day or at least 1,500 mg/day if higher dose not tolerated) and sulfonylurea (near-maximal or maximal effective dose) participated in a double-blind, active-controlled, parallel-group, 2-arm, multicentre clinical study to evaluate the efficacy of INVOKANA[®] 300 mg as add-on therapy with metformin and sulfonylurea versus sitagliptin 100 mg as add-on therapy with metformin and sulfonylurea over 52 weeks. The mean age was 57 years, 56% of patients were men, and the mean baseline eGFR was 88 mL/min/1.73 m². Patients on near-maximal or maximal effective doses of metformin and sulfonylurea (N=716) entered a 2-week single-blind, placebo run-in period. Other patients (N=39) entered a metformin and sulfonylurea dose titration and dose stabilization period of up to 12 weeks, immediately followed by the 2-week run-in period. Following the run-in period, patients with inadequate glycemic control were randomized to the addition of INVOKANA[®] 300 mg or sitagliptin 100 mg.

As shown in [Table 25](#) and [Figure 5](#) after 52 weeks, INVOKANA[®] 300 mg provided a superior ($p < 0.05$) reduction in A1C compared to sitagliptin 100 mg (with the upper bound of the 95% confidence interval around the between-group difference below 0). In addition, a greater percent of patients achieved an A1C of $< 7.0\%$ with INVOKANA[®] 300 mg relative to sitagliptin: 47.6% of patients receiving INVOKANA[®] 300 mg and 35.3% of patients receiving sitagliptin. Patients treated with INVOKANA[®] 300 mg exhibited a significant mean decrease in percent change from baseline body weight compared to patients administered sitagliptin 100 mg. A statistically significant ($p < 0.001$) reduction in systolic blood pressure was observed with INVOKANA[®] 300 mg of -5.9 mmHg relative to sitagliptin. A similar increased incidence of hypoglycemia was observed with both INVOKANA[®] 300 mg and sitagliptin in this study, consistent with the expected increase of hypoglycemia when agents not associated with hypoglycemia are added to sulfonylurea (see **WARNINGS AND PRECAUTIONS** and **ADVERSE REACTIONS**). The proportion of patients who met glycemic withdrawal criteria (based on FPG until Week 26 and A1C thereafter) was lower with INVOKANA[®] 300 mg (10.6%) compared with sitagliptin 100 mg (22.5%).

Table 25: Results from 52-Week Clinical Study Comparing INVOKANA® to Sitagliptin as Add-on Therapy with Metformin and Sulfonylurea¹

Efficacy Parameter	INVOKANA® 300 mg + Metformin and Sulfonylurea (N=377)	Sitagliptin 100 mg + Metformin and Sulfonylurea (N=378)
A1C (%)		
Baseline (mean)	8.12	8.13
Change from baseline (adjusted mean)	-1.03	-0.66
Difference from sitagliptin (adjusted mean) (95% CI)	-0.37 ² (-0.50; -0.25)	N/A ⁴
Percent of patients achieving A1C <7%	47.6	35.3
Fasting Plasma Glucose (mmol/L)		
Baseline (mean)	9.42	9.09
Change from baseline (adjusted mean)	-1.66	-0.32
Difference from sitagliptin (adjusted mean) (95% CI)	-1.34 (-1.66; -1.01)	N/A ⁴
Body Weight		
Baseline (mean) in kg	87.6	89.6
% change from baseline (adjusted mean)	-2.5	0.3
Difference from sitagliptin (adjusted mean) (95% CI)	-2.8 ³ (-3.3; -2.2)	N/A ⁴

¹ Intent-to-treat population using last observation in study prior to glycemic rescue therapy

² Met pre-specified criteria for non-inferiority to sitagliptin (with the upper bound of the 95% CI around the between-group difference less than the pre-specified non-inferiority margin of <0.3%); in a pre-specified assessment, the upper bound of the 95% CI for INVOKANA® 300 mg was <0, indicating a superior (p<0.05) reduction in A1C relative to sitagliptin with INVOKANA® 300 mg.

³ p<0.001

⁴ N/A = Not applicable

Figure 5: Mean Change from Baseline for A1C (%) Over 52 Weeks in a Study Comparing INVOKANA® to Sitagliptin as Add-on Therapy with Metformin and Sulfonylurea

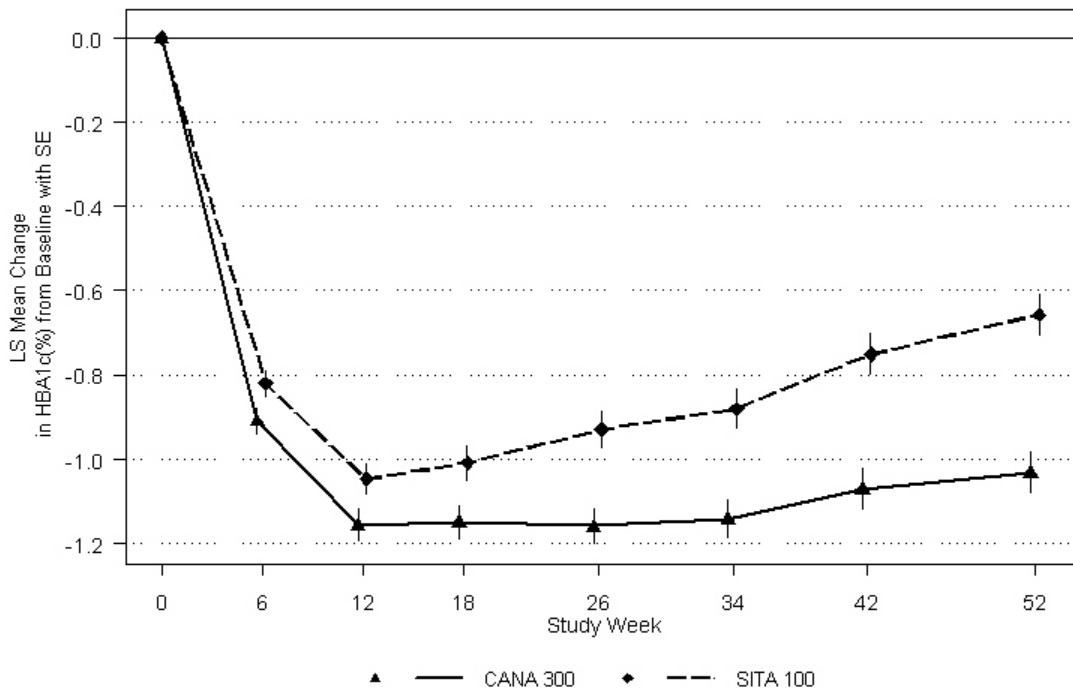

Note: LS Mean and SE in each post baseline visit are based on data with LOCF.

Add-on Therapy with Metformin and Pioglitazone (Study DIA3012)

A total of 342 patients with inadequate glycemic control (A1C level of $\geq 7.0\%$ to $\leq 10.5\%$) on the combination of metformin (2,000 mg/day or at least 1,500 mg/day if higher dose not tolerated) and pioglitazone (30 or 45 mg/day) participated in a randomized, double-blind, placebo-controlled, parallel-group, 3-arm, multicentre clinical study to evaluate the efficacy of INVOKANA® as add-on therapy with metformin and pioglitazone over 26 weeks. The mean age was 57 years, 63% of patients were men, and the mean baseline eGFR was 86 mL/min/1.73 m². Patients already on protocol-specified doses of metformin and pioglitazone (N=163) entered a 2-week, single-blind, placebo run-in period. Other patients (N=181) entered a metformin and pioglitazone dose titration and dose stabilization period for up to 12 weeks with at least 8 weeks on stable doses of metformin and pioglitazone, immediately followed by the 2-week run-in period. Following the run-in period, patients with inadequate glycemic control were randomized (N=344) to the addition of INVOKANA® 100 mg, INVOKANA® 300 mg, or placebo, administered once daily.

As shown in Table 26, statistically significant ($p < 0.001$) reductions in A1C, baseline FPG, and body weight relative to placebo were observed for INVOKANA® at Week 26. In addition, a greater percent of patients achieved an A1C of $< 7.0\%$ compared to placebo. Statistically significant reductions in systolic blood pressure were observed with INVOKANA® 100 mg and 300 mg relative to placebo of -4.1 mmHg ($p = 0.005$) and -3.5 mmHg ($p = 0.016$), respectively.

Table 26: Results from 26-Week Placebo-Controlled Clinical Study of INVOKANA® as Add-on Therapy with Metformin and Pioglitazone¹

Efficacy Parameter	INVOKANA® + Metformin and Pioglitazone 26 Weeks		Placebo + Metformin and Pioglitazone (N=115)
	100 mg (N=113)	300 mg (N=114)	
A1C (%)			
Baseline (mean)	7.99	7.84	8.00
Change from baseline (adjusted mean)	-0.89	-1.03	-0.26
Difference from placebo (adjusted mean) (95% CI)	-0.62 ² (-0.81; -0.44)	-0.76 ² (-0.95; -0.58)	N/A ³
Percent of patients achieving A1C <7%	46.9 ²	64.3 ²	32.5
Fasting Plasma Glucose (mmol/L)			
Baseline (mean)	9.38	9.11	9.13
Change from baseline (adjusted mean)	-1.49	-1.84	0.14
Difference from placebo (adjusted mean) (95% CI)	-1.63 ² (-2.05; -1.21)	-1.98 ² (-2.41; -1.56)	N/A ³
Body Weight			
Baseline (mean) in kg	94.2	94.4	94
% change from baseline (adjusted mean)	-2.8	-3.8	-0.1
Difference from placebo (adjusted mean) (95% CI)	-2.7 ² (-3.6; -1.8)	-3.7 ² (-4.6; -2.8)	N/A ³

¹ Intent-to-treat population using last observation in study prior to glycemic rescue therapy

² p<0.001 compared to placebo

³ N/A = Not applicable or not measured in this study

Add-on Therapy with Metformin and Sitagliptin (Study DIA4004)

A total of 213 patients with inadequate glycemic control (A1C level of $\geq 7.5\%$ to $\leq 10.5\%$) on the combination of metformin (greater than or equal to 1,500 mg/day) and sitagliptin 100 mg/day (or equivalent fixed-dose combination) participated in a 26-week, double-blind, placebo-controlled study to evaluate the efficacy and safety of INVOKANA® in combination with metformin and sitagliptin. The mean age was 57 years, 57% of patients were men, and the mean baseline eGFR was 90.5 mL/min/1.73 m². Following the 2-week single-blind placebo run-in period, patients were randomized to INVOKANA® 100 mg or placebo, administered once daily as add-on to metformin and sitagliptin.

At Week 6, canagliflozin was up-titrated to 300 mg in patients with an eGFR greater than or equal to 70 mL/min/1.73 m², and had a fasting self-monitoring blood glucose greater than or equal to 5.6 mmol/L, and who had not experienced reduced intravascular volume related adverse events (e.g., hypotension, postural dizziness or orthostatic hypotension). A total of 90.7% subjects were dose up-titrated to canagliflozin 300 mg in the INVOKANA® treatment group. Ten subjects were not dose up-titrated to canagliflozin 300 mg, 7 of them due to early discontinuation and the other 3 did not meet the baseline eGFR criteria and remained on canagliflozin 100 mg dose.

As shown in [Table 27](#), statistically significant reductions in A1C, FPG, and body weight relative to placebo were observed for the INVOKANA® treatment group at Week 26. In addition, a

greater percent of patients achieved an A1C of <7.0% compared to placebo. A statistically significant mean change from baseline in systolic blood pressure relative to placebo of -5.85 mmHg was observed with the INVOKANA[®] treatment group.

Table 27: Results from 26–Week Placebo-Controlled Clinical Study of INVOKANA[®] in Combination with Metformin and Sitagliptin*

Efficacy Parameter	Placebo + Metformin and Sitagliptin (N=106)	INVOKANA[®]1 + Metformin and Sitagliptin (N=107)²
A1C (%)		
Baseline (mean)	8.38	8.53
Change from baseline (adjusted mean)	-0.01	-0.91
Difference from placebo (adjusted mean) (95% CI) [†]		-0.89 [‡] (-1.19; -0.59)
Percent of patients achieving A1C < 7%	12	32
Fasting Plasma Glucose (mmol/L)		
Baseline (mean)	10.01	10.33
Change from baseline (adjusted mean)	-0.14	-1.65
Difference from placebo (adjusted mean) (95% CI) [†]		-1.50 [‡] (-2.24; -0.77)
Body Weight		
Baseline (mean) in kg	89.9	93.8
% change from baseline (adjusted mean)	-1.6	-3.4
Difference from placebo (adjusted mean) (95% CI) [†]		-1.8 [‡] (-2.7; -0.9)

* Modified Intent-to-treat population

[†] Adjusted mean and CI are derived from a mixed model for repeated measures

[‡] p<0.001

¹ 100 mg to 300 mg up-titration at Week 6

² 10 subjects did not up-titrate to canagliflozin 300 mg, 3 of whom completed Week 26

Add-on Therapy with Insulin (with or without Metformin) (Derived from DIA3008 substudy)

A total of 1718 patients with inadequate glycemic control (A1C level of ≥ 7.0 to $\leq 10.5\%$) on insulin ≥ 30 units/day or insulin add-on therapy with other antihyperglycemic agents participated in a randomized, double-blind, placebo-controlled, parallel-group, 3-arm, multicentre substudy of a cardiovascular outcomes study; this substudy evaluated the efficacy of INVOKANA[®] as add-on therapy with insulin over 18 weeks. The mean age was 63 years, 66% of patients were men, and the mean baseline eGFR was 75 mL/min/1.73 m². Patients on basal, bolus, or basal/bolus insulin, with the majority on a background basal/bolus insulin regimen, for at least 10 weeks entered a 2-week, single-blind, placebo run-in period. After the run-in period, patients with inadequate glycemic control were randomized to the addition of INVOKANA[®] 100 mg, INVOKANA[®] 300 mg, or placebo, administered once daily. The mean daily insulin dose at baseline was 83 units, which was similar across treatment groups.

Patients were stratified by (a) insulin monotherapy, (b) insulin and metformin only therapy, and (c) insulin and other antihyperglycemic agent therapy. Corresponding to approved indications,

Table 28 and Table 29 show statistically significant ($p < 0.001$) reductions in A1C, FPG, and body weight relative to placebo were observed for INVOKANA[®] at Week 18 in patients both on an insulin monotherapy and insulin+metformin background. In addition, a greater percentage of patients achieved an A1C $< 7.0\%$ compared to placebo. In the insulin monotherapy stratum, reductions in systolic blood pressure were observed with INVOKANA[®] 100 mg and 300 mg relative to placebo of -2.9 mmHg ($p = 0.027$) and -4.2 mmHg ($p = 0.001$), respectively. In the insulin and metformin only stratum, reductions in systolic blood pressure were observed with INVOKANA[®] 100 mg and 300 mg relative to placebo of -2.9 mmHg ($p = 0.011$) and -4.8 mmHg ($p < 0.001$), respectively. An increased incidence of hypoglycemia was observed in this study (see **WARNINGS AND PRECAUTIONS, ADVERSE REACTIONS, and DOSAGE AND ADMINISTRATION**).

Table 28: Results from 18-Week Placebo-Controlled Clinical Study of INVOKANA[®] as Add-on Therapy with Insulin ≥ 30 Units/Day (With Insulin Only)¹

Efficacy Parameter	INVOKANA [®] + Insulin 18 Weeks		Placebo + Insulin (N=187)
	100 mg (N=183)	300 mg (N=184)	
A1C (%)			
Baseline (mean)	8.28	8.32	8.16
Change from baseline (adjusted mean)	-0.61	-0.70	-0.06
Difference from placebo (adjusted mean) (95% CI)	-0.54 ² (-0.70; -0.39)	-0.63 ² (-0.79; -0.48)	N/A ³
Percent of patients achieving A1C $< 7\%$	24.7 ²	24.0 ²	9.3
Fasting Plasma Glucose (mmol/L)			
Baseline	9.62	9.49	9.65
Change from baseline (adjusted mean)	-1.10	-1.33	0.32
Difference from placebo (adjusted mean) (95% CI)	-1.43 ² (-1.98; -0.88)	-1.65 ² (-2.20; -1.09)	N/A ³
Body Weight			
Baseline (mean) in kg	95.8	93.5	94.5
% change from baseline (adjusted mean)	-1.9	-1.9	0.3
Difference from placebo (adjusted mean) (95% CI)	-2.2 ² (-2.7; -1.6)	-2.1 ² (-2.7; -1.6)	N/A ³

¹ Intent-to-treat population using last observation in study prior to glycemic rescue therapy

² $p < 0.001$ compared to placebo

³ N/A = Not applicable

Table 29: Results from 18-Week Placebo-Controlled Clinical Study of INVOKANA® as Add-on Therapy with Insulin ≥30 Units/Day (With Insulin and Metformin)¹

Efficacy Parameter	INVOKANA® + Insulin + Metformin 18 Weeks		Placebo + Insulin + Metformin (N=244)
	100 mg (N=241)	300 mg (N=246)	
A1C (%)			
Baseline (mean)	8.28	8.21	8.21
Change from baseline (adjusted mean)	-0.66	-0.77	0.01
Difference from placebo (adjusted mean) (95% CI)	-0.67 ² (-0.79; -0.55)	-0.78 ² (-0.90; -0.66)	N/A ³
Percent of patients achieving A1C <7%	19.6 ²	26.7 ²	7.1
Fasting Plasma Glucose (mmol/L)			
Baseline	9.38	9.35	9.34
Change from baseline (adjusted mean)	-1.06	-1.48	0.09
Difference from placebo (adjusted mean) (95% CI)	-1.15 ² (-1.56; -0.73)	-1.57 ² (-1.98; -1.16)	N/A ³
Body Weight			
Baseline (mean) in kg	97.4	98.4	99.9
% change from baseline (adjusted mean)	-1.9	-2.7	0.0
Difference from placebo (adjusted mean) (95% CI)	-1.9 ² (-2.4; -1.5)	-2.7 ² (-3.2; -2.3)	N/A ³

¹ Intent-to-treat population using last observation in study prior to glycemic rescue therapy

² p < 0.001 compared to placebo

³ N/A = Not applicable

Cardiovascular Outcomes (CANVAS (DIA3008) and CANVAS-R (DIA4003))

The effect of INVOKANA® on cardiovascular risk in adults with type 2 diabetes who had established cardiovascular (CV) disease or were at risk for CVD (two or more CV risk factors), was evaluated in the CANVAS Program (CANVAS and CANVAS-R studies). These studies were multicenter, multi-national, randomized, double-blind, placebo-controlled parallel group, time- and event-driven, with similar inclusion and exclusion criteria and patient populations. The studies compared the risk of experiencing a Major Adverse Cardiovascular Event (MACE) defined as the composite of cardiovascular death, nonfatal myocardial infarction and nonfatal stroke, between INVOKANA® and placebo on a background of standard of care treatments for diabetes and atherosclerotic cardiovascular disease. Additional pre-specified, adjudicated endpoints included CV death, fatal/non-fatal myocardial infarction, fatal/non-fatal stroke, hospitalization for heart failure, and all-cause mortality.

In CANVAS, subjects were randomly assigned 1:1:1 to canagliflozin 100 mg, canagliflozin 300 mg, or matching placebo. In CANVAS-R, subjects were randomly assigned 1:1 to canagliflozin 100 mg or matching placebo, and titration to 300 mg was permitted at the investigator's discretion (based on tolerability and glycemic needs) at Week 13 or later visits. Concomitant antidiabetic and atherosclerotic therapies could be adjusted, at the discretion of investigators, to ensure participants were treated according to the standard care for these diseases.

A total of 10,134 patients were treated (4,327 in CANVAS and 5,807 in CANVAS-R; total of 4,344 randomly assigned to placebo and 5,790 to canagliflozin). For the integrated CANVAS

trials, the mean duration of treatment was 149.2 weeks (mean of 222.8 weeks for CANVAS and 94.4 weeks for CANVAS-R) and the mean duration of study follow-up was 188.2 weeks (mean of 295.9 for CANVAS and 108.0 weeks for CANVAS-R). Vital status was obtained for 99.6% of the subjects. The proportion of subjects who completed the study was 96.0%. Approximately 78% of the study population was Caucasian, 13% was Asian, and 3% was Black. The mean age was 63 years and approximately 64% were male. All patients in the study had inadequately controlled type 2 diabetes mellitus at baseline ($\text{HbA}_{1c} \geq 7.0\%$ to $\leq 10.5\%$). The mean HbA_{1c} at baseline was 8.2% and mean duration of diabetes was 13.5 years. Baseline renal function was normal or mildly impaired in 80% of patients and moderately impaired in 20% of patients (mean eGFR 77 mL/min/1.73 m²). There were 526 patients with eGFR 30-<45 mL/min/1.73 m², 1485 patients with eGFR 45-<60 mL/min/1.73 m², and 5625 with eGFR 60-<90 mL/min/1.73 m². At baseline, 99% of patients were treated with one or more antidiabetic medications including metformin (77%), insulin (50%), and sulfonylurea (43%).

Sixty-six percent of subjects had a history of established cardiovascular disease, with 56% having a history of coronary disease, 19% with cerebrovascular disease, and 21% with peripheral vascular disease; 14% had a history of heart failure. At baseline, the mean systolic blood pressure was 137 mmHg, the mean diastolic blood pressure was 78 mmHg, the mean LDL was 2.29 mmol/L, the mean HDL was 1.2 mmol/L, and the mean urinary albumin to creatinine ratio (UACR) was 115 mg/g. At baseline, approximately 80% of patients were treated with renin angiotensin system inhibitors, 54% with beta-blockers, 13% with loop diuretics, 36% with non-loop diuretics, 75% with statins, and 74% with antiplatelet agents (including aspirin).

The primary endpoint in the CANVAS Program was the time to first occurrence of a composite MACE endpoint of cardiovascular death, nonfatal myocardial infarction, or nonfatal stroke, considering all events up to individual trial completion. The MACE hazard ratio (HR) in patients treated with canagliflozin compared with placebo and its 95% CI was estimated using a stratified Cox proportional hazards regression model with stratification by study and by established cardiovascular disease (HR: 0.86; 95% CI 0.75, 0.97, $p < 0.0001$ for non-inferiority; $p = 0.0158$ for superiority). According to the primary hypothesis, the integrated canagliflozin treatment (CANVAS and CANVAS-R) was found to be non-inferior to placebo, since the upper bound of the 95% CI was below 1.3 and superior to placebo, since the upper bound of the 95% CI was also below 1.0. Each of the components of the MACE composite endpoint showed a similar reduction when assessed as independent endpoints (see [Figure 6](#)). Results for the 100 mg and 300 mg canagliflozin doses were consistent with results for the combined dose groups. The reduction in MACE was accounted for by the subgroup of patients with established cardiovascular disease (HR 0.82; 95% CI 0.72, 0.95) (see [Figure 6](#)), whilst the subgroup of patients with only risk factors for cardiovascular disease at baseline had a hazard ratio whose 95% confidence interval included one (HR 0.98; 95% CI 0.74, 1.30).

Figure 6: Treatment Effect for Cardiovascular Events (CANVAS Integrated and Subjects with Established CV Disease)

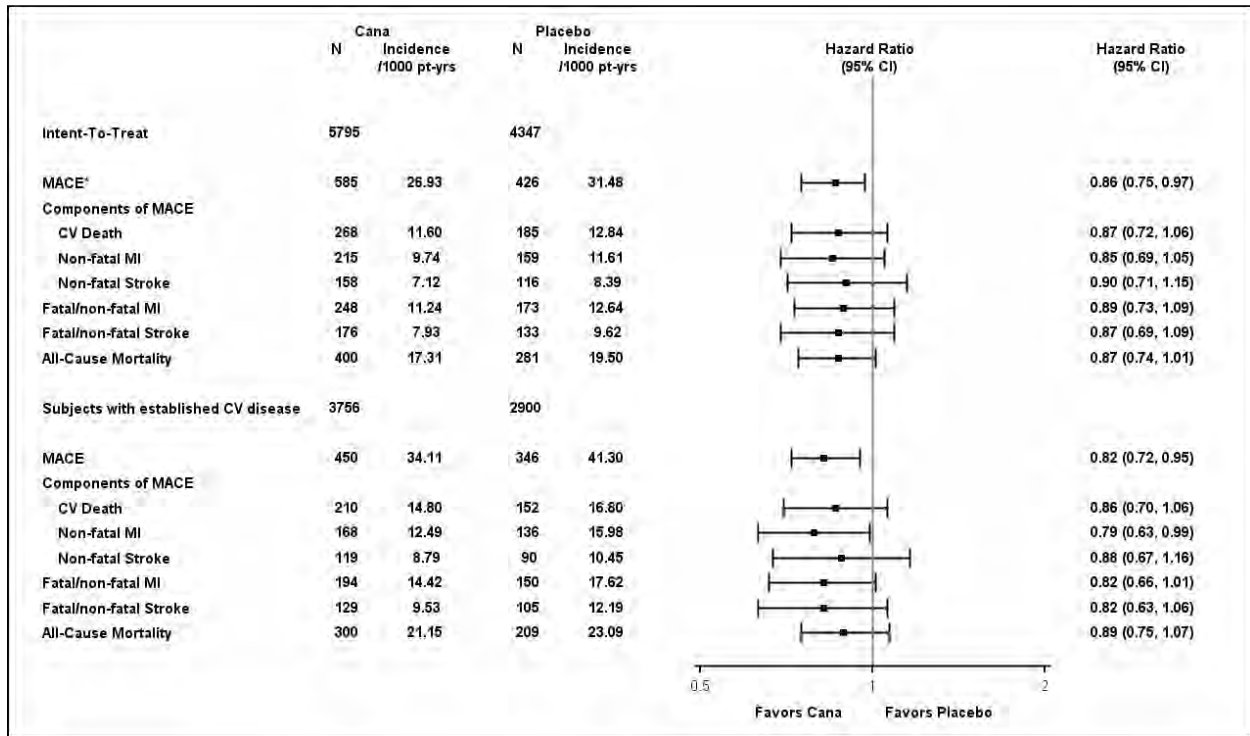

* P value for superiority (2-sided) = 0.0158.

Based on the Kaplan-Meier plot for the first occurrence of MACE, shown below, the reduction in MACE in the canagliflozin group was observed as early as Week 26 and was maintained throughout the remainder of the study (Figure 7 and Figure 8).

Figure 7: Time to First Occurrence of MACE (CANVAS Integrated)

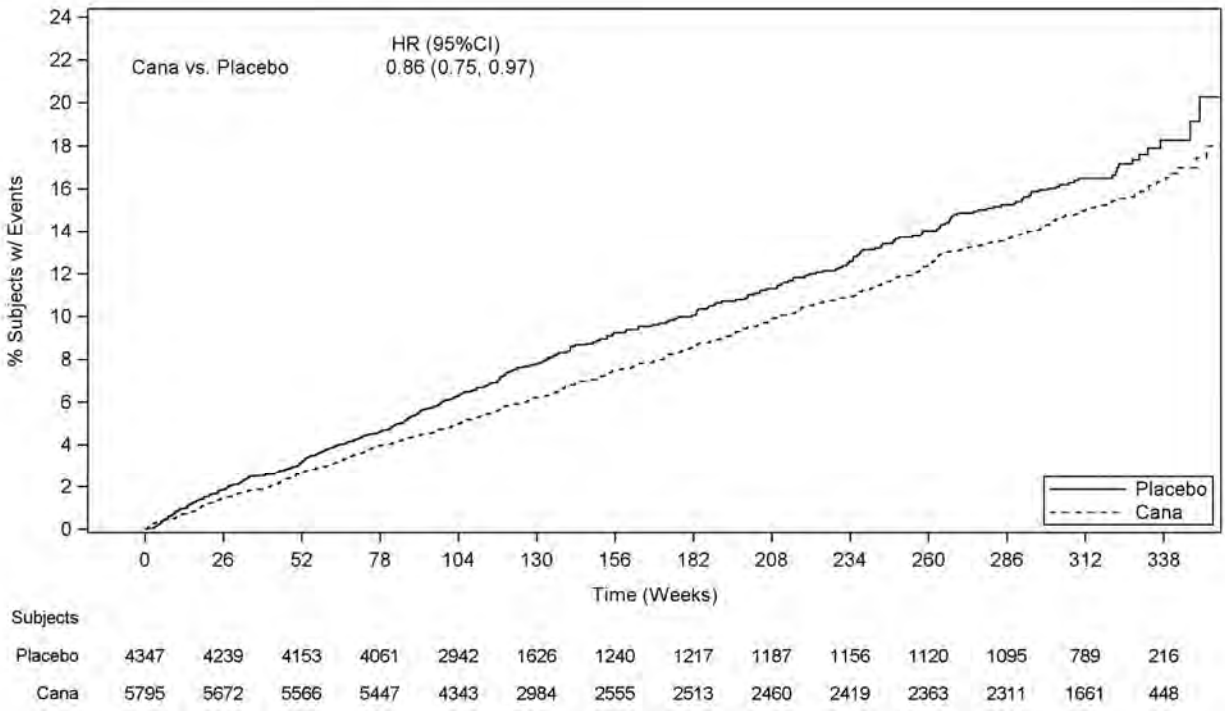
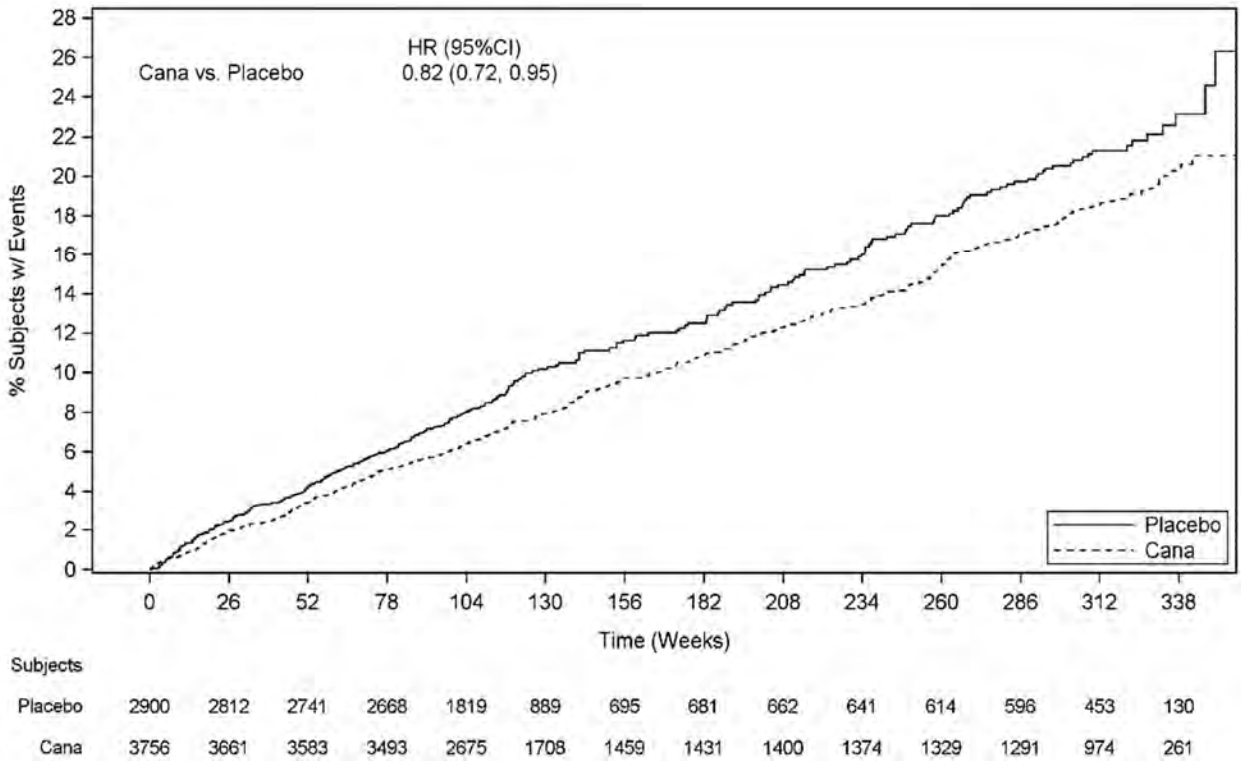

Figure 8: Time to First Occurrence of MACE (Subjects with Established CV Disease)



In the CANVAS program, subjects treated with INVOKANA[®] had a lower risk of hospitalization for heart failure compared to those treated with placebo.

Table 30: Treatment Effect for Hospitalized Heart Failure and the Composite of Death or Hospitalization due to Heart Failure

	Placebo N=4347 Event rate per 100 patient- years	INVOKANA[®] N=5795 Event rate per 100 patient- years	Hazard ratio vs. Placebo (95% CI)
Hospitalized heart failure (time to first occurrence; intent-to-treat analysis set)	0.87	0.55	0.67 (0.52, 0.87) ¹
Death or Hospitalization due to heart failure (time to first occurrence; intent-to-treat analysis set)	0.97	0.64	0.70 (0.55, 0.89)

¹ p=0.0021; nominal value

Figure 9: Time to First Occurrence of Hospitalization of Heart Failure

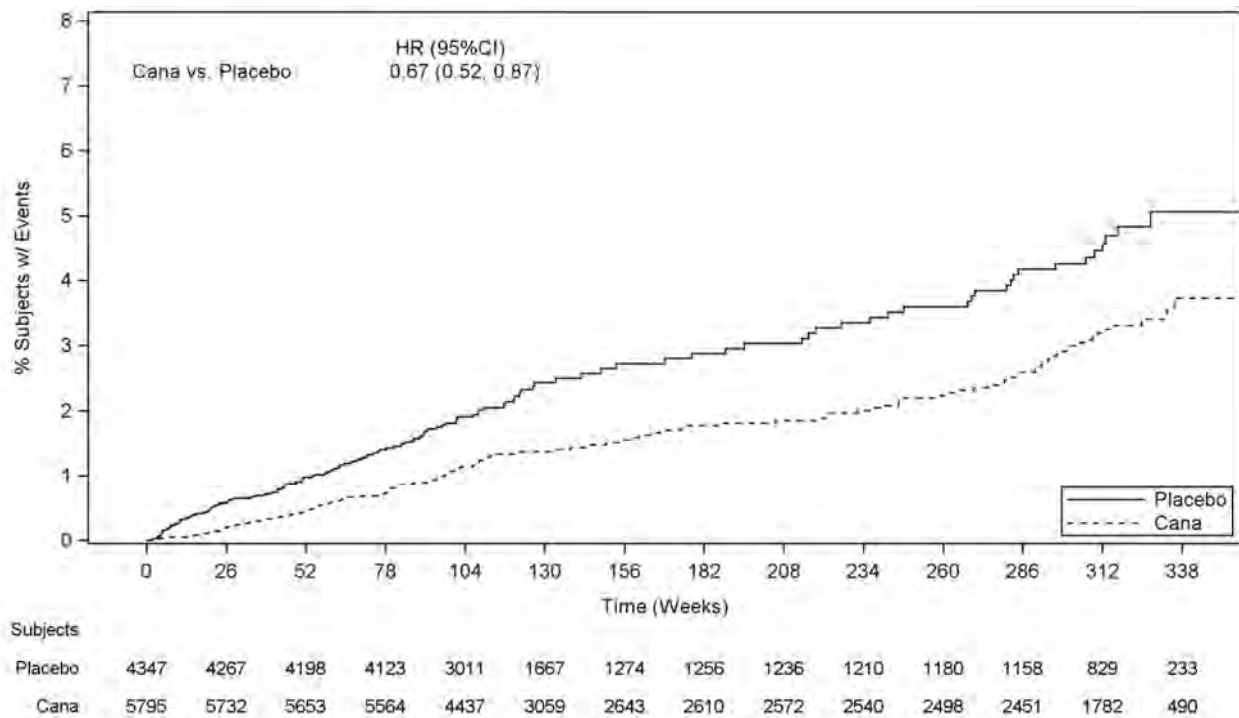

Renal and Cardiovascular Outcomes in Patients with Type 2 Diabetes Mellitus and Diabetic Nephropathy (CREDENCE DNE3001)

The Canagliflozin and Renal Events in Diabetes with Established Nephropathy Clinical Evaluation Trial (CREDENCE) studied the effect of INVOKANA[®] 100 mg relative to placebo on progression to end-stage kidney disease (ESKD), doubling of serum creatinine, and renal or cardiovascular (CV) death in adults with type 2 diabetes and diabetic nephropathy with (eGFR) ≥

30 to < 90 mL/min/1.73m² and albuminuria (> 33.9 to ≤ 565.6 mg/mmol of creatinine), who were receiving standard of care including maximally tolerated labelled dose of an angiotensin-converting enzyme inhibitor (ACEi) or angiotensin receptor blocker (ARB). This study was a multicenter, randomized, double-blind, event-driven, placebo-controlled, parallel-group, 2-arm study.

In CREDENCE, subjects were randomly assigned 1:1 to INVOKANA[®] 100mg or placebo, stratified by screening estimated glomerular filtration rate (eGFR) ≥30 to <45, ≥45 to <60, ≥60 to <90mL/min/1.73 m². Treatment with INVOKANA[®] 100 mg was continued in patients until the initiation of dialysis or renal transplantation.

A total of 4,401 subjects were randomized (2,199 randomly assigned to placebo and 2,202 to INVOKANA[®] 100mg), followed for a mean duration of 136 weeks, and included in the intent-to-treat analysis set. Four of the randomized subjects were not dosed, leading to 4,397 subjects (exposed for a mean duration of 115 weeks) in the on-treatment analysis set. Vital status was obtained for 99.9% of subjects across the study. The majority (67%) of the study population identified as White, 20% as Asian, and 5% as Black; 32% of all subjects were of Hispanic or Latino ethnicity. The mean age was 63 years and approximately 66% were male.

The mean baseline HbA1c was 8.3%, with 53.2% of subjects having baseline HbA1c ≥8%, and the baseline median urine albumin/creatinine was 104.75 mg/mmol. The most frequent antihyperglycemic agents (AHA) medications used at baseline were insulin (65.5%), biguanides (57.8%), and sulfonylureas (28.8%). Nearly all subjects (99.9%) were on ACEi or ARB at randomization. About 92% of the subjects were on cardiovascular therapies (not including ACEi/ARBs) at baseline, with approximately 60% taking an anti-thrombotic agent (including aspirin) and 69% on statins.

The mean baseline eGFR was 56.2 mL/min/1.73 m² and approximately 60% of the population had a baseline eGFR of <60 mL/min/1.73 m². Subjects had a mean duration of diabetes of approximately 16 years. The proportion of subjects with prior CV disease was 50.4%; 14.8% had a history of heart failure. While the entire study population had nephropathy at baseline, about 64% of the population had at least 2 microvascular complications (i.e. diabetic nephropathy and another microvascular complication). At baseline, 5.4% of subjects in the INVOKANA[®] 100mg arm had a history of amputation and 5.2% of subjects in the placebo arm.

The primary composite endpoint in the CREDENCE study was the time to first occurrence of ESKD (defined as an eGFR <15mL/min/1.73 m², initiation of chronic dialysis or renal transplant), doubling of serum creatinine, and renal or CV death. INVOKANA[®] 100 mg significantly reduced the risk of first occurrence of the primary composite endpoint of ESKD, doubling of serum creatinine, and renal or CV death [p<0.0001; HR:0.70; 95% CI:0.59, 0.82] (see [Figure 10](#) and [Figure 11](#)). The treatment effect reflected a reduction in progression to ESKD, doubling of serum creatinine and cardiovascular death. There were few renal deaths during the trial. The efficacy of INVOKANA[®] 100 mg on the primary endpoint composite was generally consistent across major demographic and disease subgroups, including a subgroup defined by the 3 screening eGFR strata.

INVOKANA® 100 mg significantly reduced the risk of the following secondary endpoints, as shown in Figure 10 below: Composite endpoint of CV Death and Hospitalized Heart Failure [HR:0.69; 95% CI: 0.57 to 0.83; p=0.0001], MACE (Major Adverse Cardiovascular Events) (comprised of non-fatal MI, non-fatal stroke and CV death) [HR:0.80; 95% CI:0.67 to 0.95; p=0.0121], Hospitalized Heart Failure [HR:0.61; 95% CI:0.47to 0.80; p=0.0003], and Renal composite endpoint (comprised of ESKD, doubling of serum creatinine, and renal death) [HR:0.66; 95% CI:0.53 to 0.81; p<0.0001].

For both primary and secondary endpoints, the HR in subjects treated with INVOKANA® 100 mg compared with placebo and its 95% CI were estimated using a stratified Cox proportional hazards regression model with treatment as the explanatory variable and stratified by screening eGFR (≥ 30 to < 45 , ≥ 45 to < 60 , ≥ 60 to < 90 mL/min/1.73 m²).

Figure 10: Treatment Effect for the Primary and Secondary Composite Endpoints and their Components

Forest Plot of Hazard Ratios and 95% CI of the Primary Composite Endpoint, Secondary Endpoints, and Their Components (Intention-to-Treat Analysis Set)

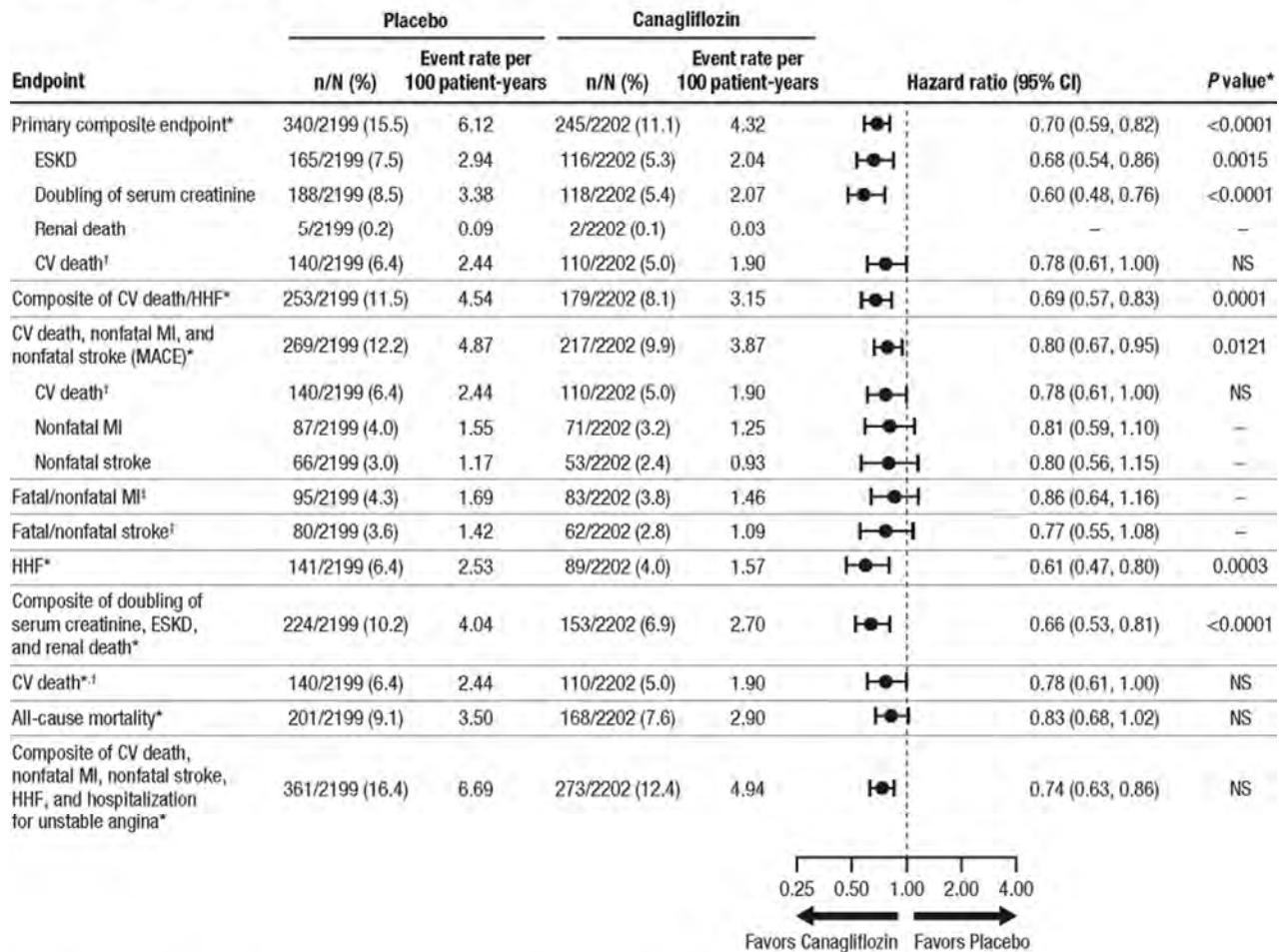

CI, confidence interval; ESKD, end-stage kidney disease; CV, cardiovascular; NS, not significant; HHF, hospitalization for heart failure; MI, myocardial infarction.

MACE is the 3-point Major Adverse Cardiac Event (CV death, nonfatal MI, and nonfatal stroke).

The individual components do not represent a breakdown of the composite outcomes, but rather the total number of subjects experiencing an event during the course of the study.

*Testing of the primary and the secondary efficacy endpoints was performed using a 2-sided alpha level of 0.022 and 0.038, respectively.

[†]CV death is being presented as a component of the primary composite endpoint, as a component of MACE, and as a secondary endpoint which underwent formal hypothesis testing.

[‡]Fatal/nonfatal MI and fatal/nonfatal stroke were not prespecified in the hierarchical testing sequence and are considered exploratory endpoints.

Based on the Kaplan-Meier plot for the time to first occurrence of the primary composite endpoint of ESKD, doubling of serum creatinine, renal death, and CV death shown below, the curves began to separate by Week 52 and continued to diverge thereafter (see [Figure 11](#)).

Figure 11: Time to First Occurrence of the Primary Composite Endpoint (ESKD, Doubling of Serum Creatinine, Renal Death, CV Death)

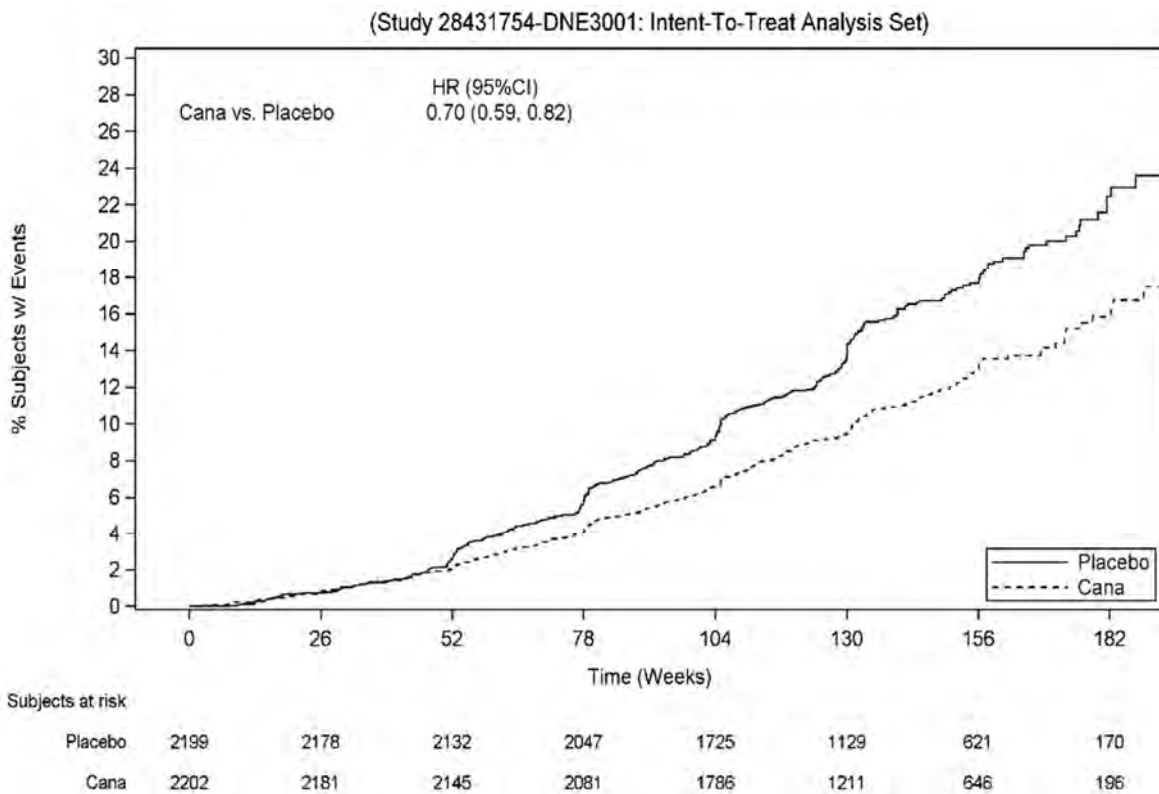

The Kaplan-Meier plot for the first occurrence of hospitalized heart failure over time is shown in [Figure 12](#). Canagliflozin significantly reduced the risk of hospitalized heart failure as compared with placebo (HR: 0.61; 95% CI: 0.47, 0.80; $p=0.0003$). The Kaplan-Meier curves separated within the first 26 weeks of treatment and continued to diverge thereafter.

Figure 12: Time to First Occurrence of Hospitalized Heart Failure

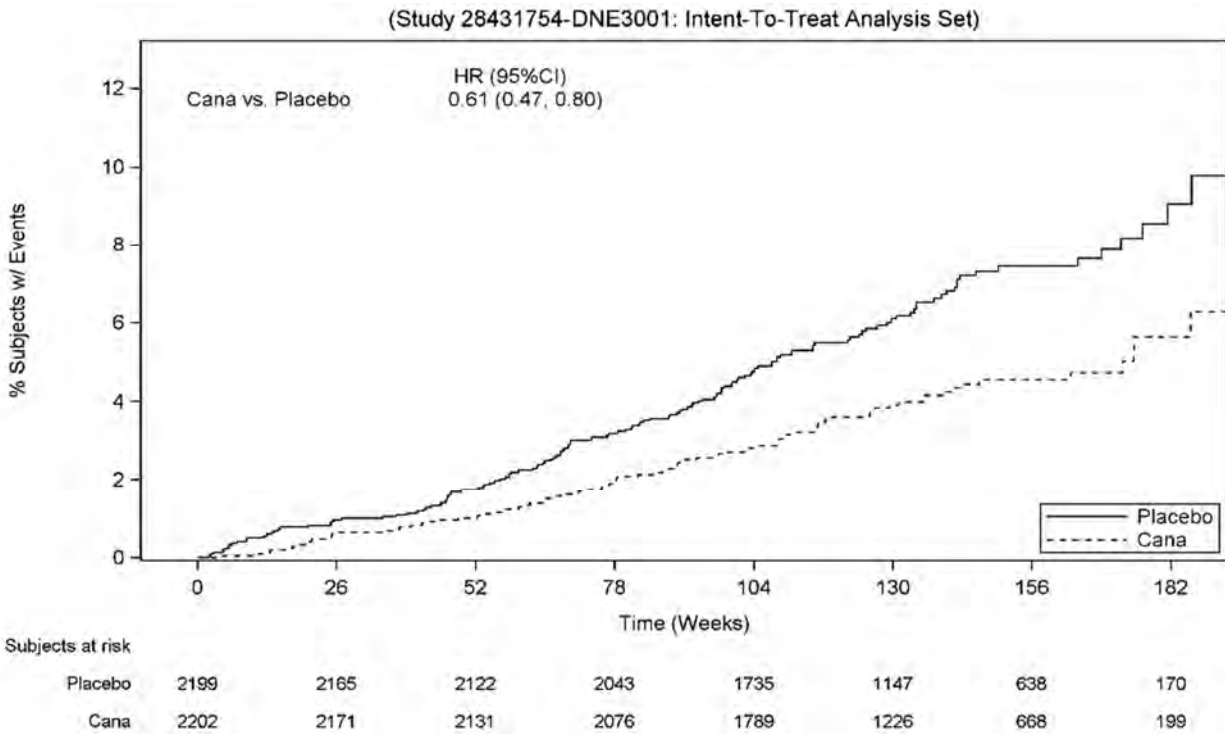

The Kaplan-Meier plot for the first occurrence of the secondary renal composite endpoint of doubling of serum creatinine, ESKD, and renal death over time is shown in [Figure 13](#). Canagliflozin significantly reduced the risk of the secondary renal composite endpoint as compared with placebo (HR: 0.66; 95% CI: 0.53, 0.81; $p < 0.0001$). The Kaplan-Meier curves separated within the first 52 weeks of treatment and continued to diverge thereafter.

Figure 13: Time to First Occurrence of Renal Composite Endpoint (Doubling of Serum Creatinine/ESKD/Renal Death)

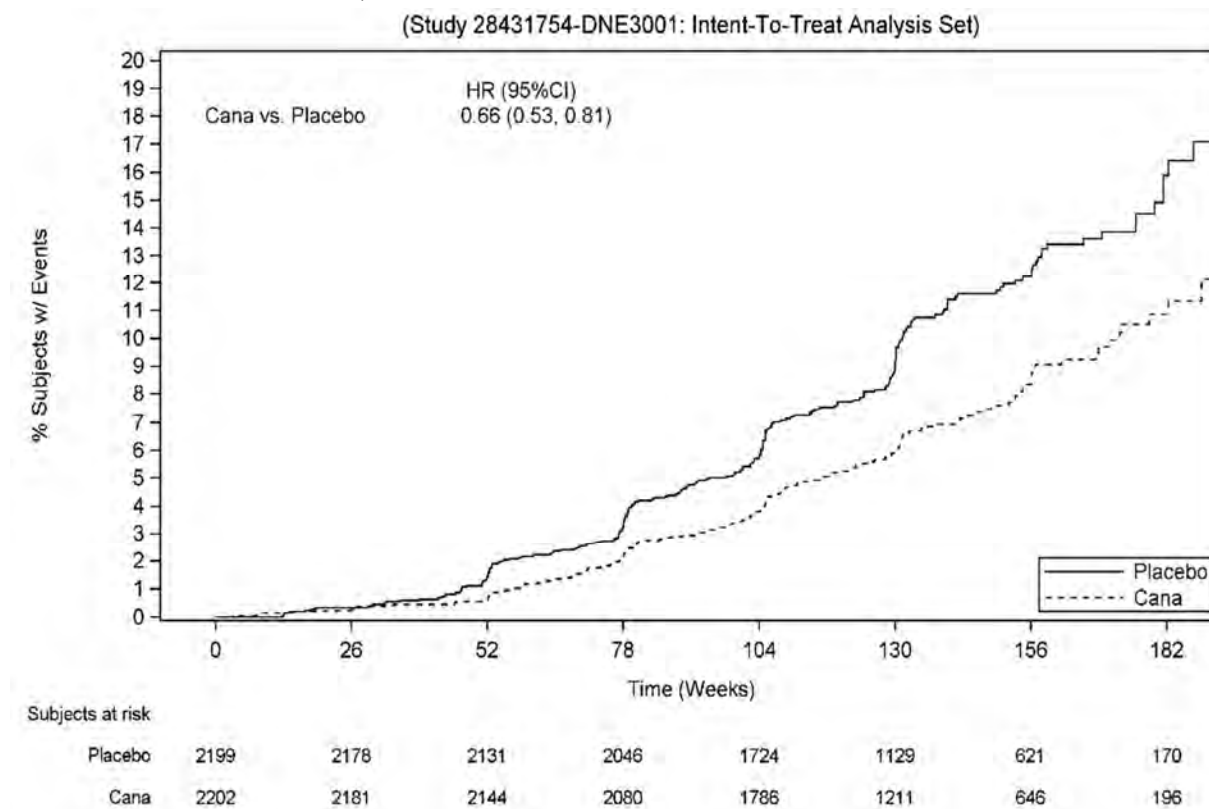

Studies in Special Populations

Study in older patients (DIA3010)

A total of 714 older patients (≥ 55 to ≤ 80 years of age) with inadequate glycemic control (baseline A1C level of ≥ 7.0 to $\leq 10.0\%$) on current diabetes therapy (either diet and exercise alone or in combination with oral or parenteral agents) participated in a randomized, double-blind, placebo-controlled study to evaluate the efficacy of INVOKANA[®] as add-on therapy with current diabetes treatment over 26 weeks. The mean age was 64 years, 55% of patients were men, and the mean baseline eGFR was 77 mL/min/1.73 m². Patients with inadequate glycemic control on their current diabetes therapy were randomized to the addition of INVOKANA[®] 100 mg, INVOKANA[®] 300 mg, or placebo, administered once daily. As shown in [Table 31](#), statistically significant ($p < 0.001$) changes from baseline in A1C, FPG, and body weight were observed for INVOKANA[®] at Week 26. In addition, a greater percent of patients achieved an A1C of $< 7.0\%$ compared to placebo (see **ACTION AND CLINICAL PHARMACOLOGY, Special Populations and Conditions**). Statistically significant ($p < 0.001$) reductions in systolic blood pressure were observed with INVOKANA[®] 100 mg and 300 mg relative to placebo of -4.6 mmHg and -7.9 mmHg, respectively.

A subset of patients (N=211) participated in the body composition substudy using DXA body composition analysis. This demonstrated that approximately two-thirds of the weight loss with INVOKANA[®] was due to loss of fat mass relative to placebo.

Table 31: Results from 26-Week Placebo-Controlled Clinical Study of INVOKANA® as Add-on Therapy with Antihyperglycemic Agents in Older Patients Inadequately Controlled on Antihyperglycemic Agents (AHAs)¹

Efficacy Parameter	INVOKANA® + Current AHA 26 Weeks		Placebo + Current AHA N=237
	100 mg N=241	300 mg N=236	
A1C (%)			
Baseline (mean)	7.77	7.69	7.76
Change from baseline (adjusted mean)	-0.60	-0.73	-0.03
Difference from placebo (adjusted mean) (95% CI)	-0.57 ² (-0.71; -0.44)	-0.70 ² (-0.84; -0.57)	N/A ³
Percent of patients achieving A1C < 7%	47.7 ²	58.5 ²	28.0
Fasting Plasma Glucose (mmol/L)			
Baseline (mean)	8.93	8.49	8.68
Change from baseline (adjusted mean)	-1.00	-1.13	0.41
Difference from placebo (adjusted mean) (95% CI)	-1.41 ² (-1.76; -1.07)	-1.54 ² (-1.88; -1.19)	N/A ³
Body Weight			
Baseline (mean) in kg	88.4	88.8	91.3
% change from baseline (adjusted mean)	-2.4	-3.1	-0.1
Difference from placebo (adjusted mean) (95% CI)	-2.3 ² (-2.8; -1.7)	-3.0 ² (-3.5; -2.4)	N/A ³

¹ Intent-to-treat population using last observation in study prior to glycemic rescue therapy

² p<0.001 compared to placebo

³ N/A = Not applicable

Patients with renal impairment (DIA3004)

A total of 269 patients with moderate renal impairment and eGFR 30 to <50 mL/min/1.73 m² inadequately controlled on current diabetes therapy (baseline A1C level of ≥7.0 to ≤10.5%) participated in a randomized, double-blind, placebo-controlled clinical study to evaluate the efficacy of INVOKANA® as add-on therapy with current diabetes treatment (diet or antihyperglycemic agent therapy with most patients on insulin and/or sulfonylurea) over 26 weeks. The mean age was 68 years, 61% of patients were men, and the mean baseline eGFR was 39 mL/min/1.73 m². Patients with inadequate glycemic control on their current diabetes therapy were randomized to the addition of INVOKANA® 100 mg, INVOKANA® 300 mg, or placebo administered once daily.

As shown in [Table 32](#), significant reductions in A1C relative to placebo were observed for INVOKANA® 100 mg and INVOKANA® 300 mg, respectively at Week 26. In addition, a greater percentage of patients achieved an A1C <7.0% compared to placebo. Patients treated with INVOKANA® exhibited mean decreases in percent change from baseline body weight compared to placebo. Reductions in systolic blood pressure were observed with INVOKANA® 100 mg and 300 mg relative to placebo of -5.7 mmHg and -6.1 mmHg, respectively. An increased incidence of hypoglycemia was observed in this study (see **WARNINGS AND**

PRECAUTIONS, ADVERSE REACTIONS and ACTION AND CLINICAL PHARMACOLOGY, Special Populations and Conditions).

Table 32: Results from 26-Week Placebo-Controlled Clinical Study of INVOKANA® as Add-on Therapy with Antihyperglycemic Agents (AHAs) in Patients with Moderate Renal Impairment¹

Efficacy Parameter	INVOKANA® + AHA (if any) 26 Weeks		Placebo + AHA (if any) N=90
	100 mg N=90	300 mg N=89	
A1C (%)			
Baseline (mean)	7.89	7.97	8.02
Change from baseline (adjusted mean)	-0.33	-0.44	-0.03
Difference from placebo (adjusted mean) (95% CI)	-0.30 (-0.53; -0.07)	-0.40 ² (-0.63; -0.17)	N/A ³
Percent of patients achieving A1C <7%	27.3	32.6	17.2
Fasting Plasma Glucose (mmol/L)			
Baseline (mean)	9.41	8.80	8.93
Change from baseline (adjusted mean)	-0.83	-0.65	0.03
Difference from placebo (adjusted mean) (95% CI)	-0.85 (-1.58; -0.13)	-0.67 (-1.41; 0.06)	N/A ³
Body Weight			
Baseline (mean) in kg	90.5	90.2	92.7
% change from baseline (adjusted mean)	-1.2	-1.5	0.3
Difference from placebo (adjusted mean) (95% CI)	-1.6 ² (-2.3; -0.8)	-1.8 ² (-2.6; -1.0)	N/A ³

¹ Intent-to-treat population using last observation in study prior to glycemic rescue therapy

² p<0.001 compared to placebo

³ N/A = Not applicable

Integrated analysis of patients with moderate renal impairment:

An analysis of a pooled patient population (N=1085) with moderate renal impairment (baseline eGFR 30 to <60 mL/min/1.73 m²) from four placebo-controlled studies was conducted to evaluate the change from baseline A1C and percent change from baseline in body weight in these patients. The mean eGFR in this analysis was 48 mL/min/1.73 m², which was similar across all treatment groups. Most patients were on insulin and/or sulfonylurea.

This analysis demonstrated that INVOKANA® provided statistically significant (p<0.001) reductions in A1C and body weight compared to placebo (see [Table 33](#)). An increased incidence of hypoglycemia was observed in this integrated analysis (see **WARNINGS AND PRECAUTIONS** and **ADVERSE REACTIONS**).

Table 33: Integrated Analysis of Four Phase 3 Clinical Studies in Patients with Moderate Renal Impairment¹

Efficacy Parameter	INVOKANA [®] + AHA (if any)		Placebo + AHA (if any) N=382
	100 mg N=338	300 mg N=365	
A1C (%)			
Baseline (mean)	8.10	8.10	8.01
Change from baseline (adjusted mean)	-0.52	-0.62	-0.14
Difference from placebo (adjusted mean) (95%CI)	-0.38 ² (-0.50; -0.26)	-0.47 ² (-0.59; -0.35)	N/A ³
Body Weight			
Baseline (mean) in kg	90.3	90.1	92.4
% change from baseline (adjusted mean)	-2.0	-2.4	-0.5
Difference from placebo (adjusted mean) (95%CI)	-1.6 ² (-2.0; -1.1)	-1.9 ² (-2.3; -1.5)	N/A ³

¹ Intent-to-treat population using last observation in study prior to glycemic rescue therapy

² p<0.001

³ N/A = Not applicable

DETAILED PHARMACOLOGY

In Vitro Pharmacology Studies

In Chinese hamster ovary K1 (CHOK1) cells overexpressing either human SGLT1 (hSGLT1) or hSGLT2, canagliflozin was found to be a potent and selective inhibitor of SGLT2 with IC₅₀ values of 4.2 nM and 663 nM against hSGLT2 and hSGLT1, respectively. Similar IC₅₀ values of 3.7 nM and 555 nM were obtained for rat SGLT2 and SGLT1 expressed in CHOK1 cells, respectively.

In Vivo Pharmacology Studies

In diabetic mice, rats, and obese dogs, canagliflozin increased urinary glucose excretion (UGE) in a dose-related manner and also decreased plasma glucose. In the oral glucose tolerance test (OGTT), canagliflozin improved glucose tolerance in normal mice, Zucker diabetic Fatty (ZDF) rats, and obese dogs. Canagliflozin treatment (1 mg/kg single oral dose) markedly lowered the mean renal threshold of glucose (RT_G) in ZDF rats from 415 to 140 mg/dL (~23 to 8 mmol/L). Repeated daily treatment for 4 weeks with canagliflozin dose-dependently lowered fed and fasted blood glucose levels, lowered A1C, and improved beta-cell function as reflected by a dose-dependent increase in plasma insulin levels in ZDF rats. In addition, repeated dosing of canagliflozin for up to 4 weeks in obese (*ob/ob*) and diet-induced obese mice reduced body weight and improved glucose handling during an OGTT.

TOXICOLOGY

Non-clinical data reveal no particular hazard for humans based on conventional studies of safety pharmacology, repeated dose toxicity, and genotoxicity. In a study in juvenile rats, dilatation of the renal pelvis and tubules was noticed beginning at the lowest dose tested, 4 mg/kg, an exposure greater than or equal to 0.5 times the maximum clinical dose of 300 mg, and the pelvic

dilatation did not fully reverse within the approximately 1-month recovery period. Persistent renal findings in juvenile rats can most likely be attributed to reduced ability of the developing rat kidney to handle canagliflozin-increased urine volumes, as functional maturation of the rat kidney continues through 6 weeks of age.

Single and Repeat-Dose Toxicity

Canagliflozin has relatively low acute oral toxicity, with maximum non-lethal single doses of 2000 mg/kg in mice (both sexes) and male rats, and 1000 mg/kg in female rats.

Repeat-dose oral toxicity studies were conducted in mice, rats and dogs for up to 3, 6 and 12 months, respectively. Canagliflozin was generally well tolerated up to oral doses of 4 mg/kg/day in rats and 100 mg/kg/day in mice and dogs (up to approximately 0.5, 11, and 20 times the clinical dose of 300 mg based on AUC exposure for rats, mice and dogs, respectively). The major adverse effects, observed mainly in rats, were related to the pharmacologic mode of action of canagliflozin, and these included increased urinary glucose, increased urine volume, increased urinary excretion of electrolytes, decreased plasma glucose at high dose levels, and reduced body weight. The primary targets of toxicity were the kidney and bone. In the 3-month rat study, minimal mineralization of renal interstitium and/or pelvis were observed in some animals given doses of ≥ 4 mg/kg/day. In the 6-month rat study, renal tubular dilatation was seen at all doses (4, 20 and 100 mg/kg/day), and an increased incidence and severity of transitional epithelial hyperplasia in the renal pelvis was observed at 100 mg/kg/day. In dogs, treatment-related tubular regeneration/degeneration and tubular dilatation occurred only at the high dose of 200/100 mg/kg/day. Trabecular hyperostosis was observed in the repeat-dose studies in rats, but not in mice and dogs. In the 2-week rat study, canagliflozin at 150 mg/kg/day caused minimal to mild hyperostosis but in 3- and 6-month rat studies, hyperostosis was detected at 4 mg/kg/day, the lowest dose tested. A 1-month mechanistic rat study showed that hyperostosis occurred in young, actively growing animals (6 to 8 weeks old, as in the toxicity studies) but not in older (6-month old) animals where bone growth has substantially slowed.

Carcinogenicity

The carcinogenicity of canagliflozin was evaluated in 2-year studies in mice and rats at oral doses of 10, 30, or 100 mg/kg/day. Canagliflozin did not increase the incidence of tumors in male and female mice up to 100 mg/kg/day (up to 14 times the clinical dose of 300 mg based on AUC exposure).

The incidence of testicular Leydig cell tumors increased significantly in male rats at all doses tested (≥ 1.5 times the clinical dose of 300 mg based on AUC exposure). The Leydig cell tumors are associated with an increase in luteinizing hormone (LH), which is a known mechanism of Leydig cell tumor formation in rats. In a 12-week clinical study, unstimulated LH did not increase in males treated with canagliflozin.

The incidence of pheochromocytomas and renal tubular tumors increased significantly in male and female rats given high doses of 100 mg/kg/day (approximately 12 times the clinical dose of 300 mg based on AUC exposure). Canagliflozin-induced renal tubule tumors and pheochromocytomas in rats may be caused by carbohydrate malabsorption; mechanistic clinical

studies have not demonstrated carbohydrate malabsorption in humans at canagliflozin doses of up to 2 times the recommended clinical dose of 300 mg.

Mutagenicity

Canagliflozin was not mutagenic with or without metabolic activation in the Ames assay. Canagliflozin was mutagenic in the *in vitro* mouse lymphoma assay with but not without metabolic activation. Canagliflozin was not mutagenic or clastogenic in an *in vivo* oral micronucleus assay in rats and an *in vivo* oral Comet assay in rats.

Reproductive and Developmental Toxicity

In rat fertility studies, canagliflozin had no adverse effects on mating, fertility, or early embryonic development up to the highest dose of 100 mg/kg/day (up to 19 times the clinical dose of 300 mg based on AUC exposure), although there were slight sperm morphological changes at this dose level.

Canagliflozin was not teratogenic at any dose tested when administered orally to pregnant rats and rabbits during the period of organogenesis. In both rats and rabbits, a slight increase in the number of fetuses with reduced ossification, indicative of a slight developmental delay, was observed at the high doses (approximately 19 times the clinical dose of 300 mg based on AUC exposure) in the presence of maternal toxicity.

In a pre- and postnatal development study, canagliflozin administered orally to female rats from gestation Day 6 to lactation Day 20 resulted in decreased body weights in male and female offspring at maternally toxic doses of ≥ 30 mg/kg/day (≥ 5.9 times the clinical dose of 300 mg based on AUC exposure). Maternal toxicity was limited to decreased body weight gain.

In a juvenile toxicity study in which canagliflozin was dosed orally to young rats from postnatal day (PND) 21 until PND 90 at doses of 4, 20, 65, or 100 mg/kg, increased kidney weights and a dose-related increase in the incidence and severity of renal pelvic and renal tubular dilatation were reported at all dose levels. Exposure at the lowest dose tested was approximately 0.5 times the maximum recommended clinical dose of 300 mg. The renal pelvic dilatations observed in juvenile animals did not fully reverse within the 1-month recovery period. Additionally, shortened ulna growth and delays in sexual maturation were observed in juvenile rats at doses that were greater than or equal to 3 times and 9 times the clinical dose of 300 mg based on AUC exposure, respectively.

REFERENCES

1. Devineni D, Morrow L, Hompesch M et al. Canagliflozin improves glycemic control over 28 days in subjects with type 2 diabetes not optimally controlled on insulin. *Diabetes Obes Metab* 2012;14(6):539–545.
2. Liang Y, Arakawa K, Ueta K et al. Effect of canagliflozin on renal threshold for glucose, glycemia, and body weight in normal and diabetic animal models. *PLoS ONE* [serial online] 2012; 7(2): e30555:1-7.
3. Neal B, Perkovic V, Mahaffey K et al. Canagliflozin and Cardiovascular and Renal Events in Type 2 Diabetes. *N Engl J Med* 2017;377:644-57.
4. Perkovic V, Jardine M, Neal B et al. Canagliflozin and Renal Outcomes in Type 2 Diabetes and Nephropathy. *N Engl J Med* 2019;380:2295-2306.
5. Rosenstock J, Aggarwal N, Polidori D et al. Dose-ranging effects of canagliflozin, a sodium-glucose cotransporter 2 inhibitor, as add-on to metformin in subjects with type 2 diabetes. *Diabetes Care*. 2012; 35:1232-1238.

PART III: CONSUMER INFORMATION

**PrINVOKANA®
canagliflozin tablets**

This leaflet is Part III of a three-part "Product Monograph" published when INVOKANA® was approved for sale in Canada and is designed specifically for Consumers. Read this carefully before you start taking INVOKANA® and each time you get a refill. This leaflet is a summary and will not tell you everything about this drug. Talk to your healthcare professional about your medical condition and treatment and ask if there is any new information about INVOKANA®.

ABOUT THIS MEDICATION

What the medication is used for:

INVOKANA® is used along with diet and exercise to improve blood sugar levels in adults with type 2 diabetes. INVOKANA® can be used:

- alone, in patients who cannot take metformin, or
- along with metformin, or
- along with a sulfonylurea, or
- along with metformin and a sulfonylurea, or
- along with metformin and a pioglitazone, or
- along with metformin and sitagliptin or
- along with insulin (with or without metformin).

INVOKANA® can also be used, along with diet and exercise, if you have type 2 diabetes and:

- an increased cardiovascular risk. This means that you have or may have health problems due to your heart and blood vessels. INVOKANA® can be used to lower your risk of dying from events related to your heart or blood vessels. It may also lower your risk of having heart attacks and strokes.
- diabetic kidney disease. This is when your kidneys are damaged as a result of your diabetes. INVOKANA® can be used to lower the risk that your kidney function will worsen to the point where your kidneys fail and you need dialysis. As well, INVOKANA® may also lower your risk of dying from events related to your heart and blood vessels.

What it does:

INVOKANA® works by increasing the amount of sugar removed from the body in the urine, which reduces the amount of sugar in the blood.

What is type 2 diabetes?

Type 2 diabetes is a condition in which your body does not make enough insulin, and/or does not use the insulin that your body produces as well as it should. When this happens,

sugar (glucose) builds up in the blood. This can lead to serious problems.

When it should not be used:

Do not take INVOKANA® if you:

- are allergic to canagliflozin or any of the other ingredients in this medication.
- have type 1 diabetes. This is a disease where your body does not produce any insulin.
- have or have had diabetic ketoacidosis (DKA). This is a complication of diabetes.
- you are on dialysis.

What the medicinal ingredient is:

Canagliflozin

What the nonmedicinal ingredients are:

Croscarmellose sodium, hydroxypropyl cellulose, iron oxide yellow (100 mg tablet only), lactose anhydrous, Macrogol (polyethylene glycol), magnesium stearate, microcrystalline cellulose, polyvinyl alcohol, talc, titanium dioxide.

What dosage forms it comes in:

100 mg tablets: Yellow, capsule-shaped tablets with "CFZ" on one side and "100" on the other side.

300 mg tablets: White, capsule-shaped tablets with "CFZ" on one side and "300" on the other side.

WARNINGS AND PRECAUTIONS

Serious Warnings and Precautions

Diabetic Ketoacidosis (DKA)

- DKA is a serious and life-threatening condition that requires urgent hospitalization. DKA has been reported in patients with type 2 diabetes mellitus (T2DM), with normal or high blood sugar levels, who are treated with INVOKANA® or with other sodium-glucose co-transporter 2 (SGLT2) inhibitors. Some cases of DKA have led to death.
- Seek medical attention right away and stop taking INVOKANA® immediately if you have any of the following symptoms (even if your blood sugar levels are normal): difficulty breathing, nausea, vomiting, stomach pain, loss of appetite, confusion, feeling very thirsty, feeling unusually tired or sleepy, a sweet smell to the breath, a sweet or metallic taste in the mouth, or a different odour to urine or sweat.
- If you have diabetic kidney disease, you may have a higher chance of DKA while you are taking INVOKANA®.
- INVOKANA® should not be used in patients with type 1 diabetes.
- INVOKANA® should not be used to treat DKA or if you have a history of DKA.

Lower Limb Amputation

- INVOKANA[®] may increase your risk of lower limb amputations. Amputations mainly involve removal of the toe or part of the foot but could also involve the leg, below and above the knee. Some people had more than one amputation, some on both sides of the body.
- Seek medical attention if you have new pain or tenderness, any sores, ulcers, or infections in your leg or foot. Your doctor may decide to stop your INVOKANA[®] if you have any of these signs or symptoms. Talk to your doctor about proper foot care and keeping hydrated.

BEFORE you use INVOKANA[®] talk to your doctor or pharmacist if you:

- have an increased chance of developing DKA, including if you:
 - are dehydrated or suffer from excessive vomiting, diarrhea, or sweating;
 - are on a very low carbohydrate diet;
 - have been fasting for a while;
 - are eating less, or there is a change in your diet;
 - drink a lot of alcohol;
 - have/have had problems with your pancreas, including pancreatitis or surgery on your pancreas;
 - are hospitalized for major surgery, or are about to have major surgery;
 - are hospitalized for serious infection or serious medical illnesses;
 - have an acute illness;
 - have sudden reductions in insulin dose;
 - have diabetic kidney disease;
 - have a history of diabetic ketoacidosis (DKA).
- have an increased chance of needing an amputation, including if you:
 - have a history of amputation
 - have heart disease or are at risk for heart disease
 - have had blocked or narrowed blood vessels, usually in your leg
 - have damage to the nerves (neuropathy) in your leg
 - have had diabetic foot ulcers or sores
 - have a lower limb infection
 - are dehydrated
- have or have had low pressure (hypotension) or are taking medicines to:
 - remove excess water from your body. These are called diuretics or water pills. An example is furosemide.

- lower your blood pressure. Examples are angiotensin-converting enzyme (ACE) inhibitors, angiotensin receptor blockers (ARB).

Taking INVOKANA[®] with any of these medicines may increase your risk for dehydration and/or low blood pressure.

- are older than 65 years of age.
- are taking medicines to lower your blood sugar such as glyburide, gliclazide or glimepiride (sulfonylureas) or insulin. Taking INVOKANA[®] with any of these medicines can increase the risk of having low blood sugar (hypoglycemia). Take precautions to avoid the potential for low blood sugar while driving or using heavy machinery.
- are taking medicines used to treat pain and reduce inflammation and fever known as NSAIDs (nonsteroidal anti-inflammatory drugs). Taking INVOKANA[®] with these medicines can increase the risk for kidney problems.
- have liver problems.
- have heart problems.
- have intolerance to some milk sugars. INVOKANA[®] tablets contain lactose.
- are pregnant or are planning to have a baby. INVOKANA[®] should not be used during pregnancy.
- are breast-feeding. INVOKANA[®] should not be used during breast-feeding.
- often get urinary tract infections

INVOKANA[®] is not recommended for use in patients under 18 years of age.

INVOKANA[®] will cause your urine to test positive for sugar (glucose).

Taking INVOKANA[®] increases your risk of breaking a bone. Talk to your doctor about factors that may increase your risk of bone fracture.

While taking INVOKANA[®] your doctor may order a blood test to check your kidney function, blood fat levels (Low-Density Lipoprotein cholesterol or LDL-C) amount of red blood cells in your blood (haematocrit), and potassium blood levels.

INVOKANA[®] may cause necrotizing fasciitis of the perineum (area between and around the anus and genitals). This is a rare but serious and potentially life-threatening infection that can affect both men and women. It is also known as Fournier's gangrene and requires urgent treatment. If you experience tenderness, redness or swelling of the genitals or the area from the genitals back to the rectum, especially if you also have a fever or are feeling very weak, tired, or uncomfortable, seek medical attention immediately. These may be signs of Fournier's gangrene.

If you are going to have a surgery and after your surgery, or if you are hospitalized for a serious infection, a serious medical illness, or a major surgery, your doctor may stop your INVOKANA®. Talk to your doctor about when to stop taking INVOKANA® and when to start it again. Your doctor will check for ketones in your blood or urine.

Driving and using machines: INVOKANA® may cause dizziness or light-headedness. DO NOT drive or use machines until you know how the medicine affects you.

INTERACTIONS WITH THIS MEDICATION

Tell your doctor or pharmacist if you are taking, have recently taken, or might take any other medicines. This is because this medicine may affect the way INVOKANA® works.

Drugs that may interact with INVOKANA® include:

- digoxin, a medicine used to treat heart problems.
- furosemide or other diuretics (water pills).
- an ACE inhibitor or an ARB (to lower your blood pressure).
- insulin or a sulfonylurea (such as glimepiride, glielazide, or glyburide).
- carbamazepine, phenytoin or phenobarbital.
- efavirenz or ritonavir.
- rifampin.
- St. John’s wort.

PROPER USE OF THIS MEDICATION

Usual starting dose:

100 mg by mouth each day with or without food. Your doctor may increase your dose to 300 mg per day. However, if you have a kidney problem, your dose may stay at 100 mg per day.

It is best to take INVOKANA® before the first meal of the day and at the same time each day. Swallow the tablet whole with water.

Before starting INVOKANA®, your doctor will do tests to see how well your kidneys are working.

Overdose:

In case of drug overdose, contact a health care practitioner, hospital emergency department or regional Poison Control Centre immediately, even if there are no symptoms.

Missed dose:

- If you forget to take a dose of INVOKANA®, take it as soon as you remember. However, if it is nearly time for the next dose, skip the missed dose and follow your usual schedule.
- Do not take two doses on the same day to make up for a forgotten dose.

SIDE EFFECTS AND WHAT TO DO ABOUT THEM

These are not all the possible side effects you may feel when taking INVOKANA®. If you experience any side effects not listed here, contact your healthcare professional. Please also see Warnings and Precautions.

- Changes in urination such as urinating more often or in larger amounts, an urgent need to urinate, and a need to urinate at night.
- Nausea.
- Feeling thirsty.

Diabetic Ketoacidosis (DKA) is a serious, life-threatening medical condition that may lead to death. DKA can occur with normal or high blood glucose levels. DKA has happened in people with diabetes who were sick or who had surgery, during treatment with INVOKANA®. DKA requires immediate treatment in a hospital. DKA can happen with INVOKANA® even if your blood sugar is at normal or near normal levels. **Stop taking INVOKANA® immediately and get** medical help right away if you have any of the symptoms in the table below under DKA, even if your blood glucose levels are normal.

Tell your doctor if you are hospitalized for major surgery, serious infection or serious medical illness.

Increased need for lower leg or toe amputation (removal) especially if you are at high risk of heart disease. Talk to your doctor if you experience symptoms including leg pain, poor circulation, bluish, cold skin, and poor hair and toe nail growth. Good foot care and drinking an adequate amount of fluid are recommended.

SIDE EFFECTS, HOW OFTEN THEY HAPPEN AND WHAT TO DO ABOUT THEM

Frequency / Symptom / Effect	Talk with your doctor or pharmacist		Stop taking drug and call your doctor or pharmacist
	Only if severe	In all cases	
Very Common Vaginal yeast infection: vaginal odor, white or yellowish vaginal discharge and/or itching		✓	

SIDE EFFECTS, HOW OFTEN THEY HAPPEN AND WHAT TO DO ABOUT THEM

Frequency / Symptom / Effect	Talk with your doctor or pharmacist		Stop taking drug and call your doctor or pharmacist	
	Only if severe	In all cases		
Common	Hypoglycemia (low blood sugar), especially if you are also taking a sulfonylurea or insulin: shaking, sweating, pale skin, rapid heartbeat, change in vision, hunger, headache and change in mood, feeling anxious or confused		✓	
	Balanitis (yeast infection of the penis): red, swollen, itchy head of penis, thick, lumpy discharge under foreskin, unpleasant odour, difficulty retracting foreskin, pain passing urine or during sex		✓	
	Urinary tract infection: burning sensation when passing urine, pain in the pelvis, or mid-back pain, or increased need to urinate		✓	
	Constipation	✓		
	Bone fracture (broken bones)		✓	

SIDE EFFECTS, HOW OFTEN THEY HAPPEN AND WHAT TO DO ABOUT THEM

Frequency / Symptom / Effect	Talk with your doctor or pharmacist		Stop taking drug and call your doctor or pharmacist	
	Only if severe	In all cases		
Uncommon	Skin Ulcer (a break or sore on the skin with tissue breakdown) predominantly of the lower leg: It may start off red then get swollen and tender. Next, blisters can form with loss of skin layers. It can lead to an open round crater with a bad smell. Ulcers take a long time or may not heal.		✓	
	Peripheral Ischemia (blocked or narrow blood vessels): Leg pain with walking that gets better with rest. Poor circulation, bluish, cold skin, and poor nail and hair growth. It can lead to Skin Ulcers and Lower Leg or Toe Amputation.		✓	
	Dehydration (not having enough water in your body): feeling very thirsty, weak or tired, passing little or no urine and/or fast heartbeat; it can be from nausea, vomiting and/or diarrhea or not drinking enough liquids		✓	

SIDE EFFECTS, HOW OFTEN THEY HAPPEN AND WHAT TO DO ABOUT THEM

Frequency / Symptom / Effect	Talk with your doctor or pharmacist		Stop taking drug and call your doctor or pharmacist
	Only if severe	In all cases	
Hypotension (low blood pressure): dizziness, fainting or lightheadedness; may occur when you go from lying to sitting to standing up.		✓	
Rash or hives			✓
Kidney problems: nausea, vomiting, diarrhea; muscle cramps; swelling of the legs, ankles, feet, face and/or hands; shortness of breath due to extra fluid on the lungs; more frequent urination or in greater amounts than usual, with pale urine; or, less frequent urination, or in smaller amounts than usual, with dark coloured urine.		✓	
Severe hypoglycemia (low blood sugar), especially when used with insulin or a sulfonylurea: disorientation, loss of consciousness, seizure			✓
Rare			

SIDE EFFECTS, HOW OFTEN THEY HAPPEN AND WHAT TO DO ABOUT THEM

Frequency / Symptom / Effect	Talk with your doctor or pharmacist		Stop taking drug and call your doctor or pharmacist
	Only if severe	In all cases	
Diabetic Ketoacidosis (when your body produces high levels of blood acids called ketones): difficulty breathing, nausea, vomiting, stomach pain, loss of appetite, confusion, feeling very thirsty and feeling unusual tiredness, a sweet smell to the breath, a sweet or metallic taste in the mouth, or a different odour to urine or sweat			✓
Anaphylactic reaction (Severe allergic reaction): swelling of the face, lips, mouth, tongue or throat that may lead to difficulty breathing or swallowing			✓
Acute kidney infection: painful, urgent or frequent urination, lower back (flank) pain, fever or chills, cloudy or foul-smelling urine, blood in your urine			✓

SIDE EFFECTS, HOW OFTEN THEY HAPPEN AND WHAT TO DO ABOUT THEM

Frequency / Symptom / Effect	Talk with your doctor or pharmacist		Stop taking drug and call your doctor or pharmacist
	Only if severe	In all cases	
Rare	Urosepsis (severe infection that spreads from the urinary tract and throughout the body): fever or low body temperature, rapid breathing, chills, rapid heartbeat, pain with urination, difficulty urinating, frequent urination		✓
	Pancreatitis (inflammation of the pancreas): severe stomach pain that lasts and gets worse when you lie down, nausea, vomiting	✓	
	Fournier's gangrene (a serious infection affecting soft tissue around the groin): pain or tenderness, redness of the skin, or swelling in the genital or perineal area, with or without fever or feeling very weak, tired, or uncomfortable		✓

This is not a complete list of side effects. For any unexpected effects while taking INVOKANA®, contact your doctor or pharmacist.

REPORTING SIDE EFFECTS

You can report any suspected side effects associated with the use of health products to Health Canada by:

- Visiting the Web page on Adverse Reaction Reporting (<https://www.canada.ca/en/health-canada/services/drugs-health-products/medeffect-canada/adverse-reaction-reporting.html>) for information on how to report online, by mail or by fax; or
- Calling toll-free at 1-866-234-2345.

NOTE: Contact your health professional if you need information about how to manage your side effects. The Canada Vigilance Program does not provide medical advice.

HOW TO STORE IT

- This medicine does not require any special storage conditions.
- Store at room temperature (15-30°C).
- Keep out of the reach and sight of children.
- Do not use INVOKANA® after the expiry date which is stated on the label after EXP. The expiry date refers to the last day of that month.
- Do not throw away any medicines via waste water or household waste. Ask your pharmacist how to throw away medicines you no longer use. These measures will help protect the environment.

MORE INFORMATION

NOTE: This INFORMATION FOR THE CONSUMER leaflet provides you with the most current information at the time of printing

For questions, concerns, or the Product Monograph go to www.janssen.com/canada or call: 1-800-567-3331 and 1-800-387-8781

This leaflet was prepared by JANSSEN Inc. Toronto, Ontario M3C 1L9

Last revised: May 20, 2020

Signature

User	Date	Reason
------	------	--------

HIGHLIGHTS OF PRESCRIBING INFORMATION

These highlights do not include all the information needed to use INVOKANA® safely and effectively. See full prescribing information for INVOKANA.

INVOKANA (canagliflozin) tablets, for oral use
Initial U.S. Approval: 2013

RECENT MAJOR CHANGES

Boxed Warning, Lower Limb Amputation	Removed 08/2020
Indications and Usage (1)	08/2020
Dosage and Administration (2.1, 2.2, 2.3)	08/2020
Contraindications, Patients with severe renal impairment being treated for glycemic control (4)	Removed 08/2020
Warnings and Precautions (5.1, 5.2, 5.3)	08/2020
Warnings and Precautions, Increases in Low-Density Lipoprotein (5.11)	Removed 09/2019

INDICATIONS AND USAGE

INVOKANA is a sodium-glucose co-transporter 2 (SGLT2) inhibitor indicated:

- as an adjunct to diet and exercise to improve glycemic control in adults with type 2 diabetes mellitus (1)
- to reduce the risk of major adverse cardiovascular events in adults with type 2 diabetes mellitus and established cardiovascular disease (1)
- to reduce the risk of end-stage kidney disease, doubling of serum creatinine, cardiovascular death, and hospitalization for heart failure in adults with type 2 diabetes mellitus and diabetic nephropathy with albuminuria (1).

Limitations of Use:

- INVOKANA is not recommended in patients with type 1 diabetes mellitus. It may increase the risk of diabetic ketoacidosis in these patients (1)
- INVOKANA is not recommended for use to improve glycemic control in adults with type 2 diabetes mellitus with an eGFR less than 30 mL/min/1.73 m² (1)

DOSAGE AND ADMINISTRATION

- The recommended starting dose is 100 mg once daily, taken before the first meal of the day (2.2)
- Dose can be increased to 300 mg once daily in patients tolerating INVOKANA 100 mg once daily who have an eGFR of 60 mL/min/1.73 m² or greater and require additional glycemic control (2.2)
- Assess renal function before initiating and as clinically indicated (2.1)
- Dose adjustment for patients with renal impairment may be required (2.2)
- Adjust dose when taken concomitantly with UGT inducer (2.3, 7.1)

DOSAGE FORMS AND STRENGTHS

Tablets: 100 mg, 300 mg (3)

CONTRAINDICATIONS

- Serious hypersensitivity reaction to INVOKANA (4, 5.8)
- On dialysis (4)

WARNINGS AND PRECAUTIONS

- **Lower Limb Amputation:** Consider factors that may increase the risk of amputation before initiating INVOKANA. Monitor patients for infection or ulcers of lower limb and discontinue if these occur (5.1)
- **Volume Depletion:** May result in acute kidney injury. Before initiating INVOKANA, assess and correct volume status in patients with renal impairment, elderly patients, or patients on loop diuretics. Monitor for signs and symptoms during therapy (5.2, 6.1)
- **Ketoacidosis:** Assess patients who present with signs and symptoms of metabolic acidosis for ketoacidosis, regardless of blood glucose level. If suspected, discontinue INVOKANA, evaluate and treat promptly. Before initiating INVOKANA, consider risk factors for ketoacidosis. Patients on INVOKANA may require monitoring and temporary discontinuation of therapy in clinical situations known to predispose to ketoacidosis (5.3)
- **Urosepsis and pyelonephritis:** Evaluate patients for signs and symptoms of urinary tract infections and treat promptly, if indicated (5.4)
- **Hypoglycemia:** Consider a lower dose of insulin or the insulin secretagogue to reduce the risk of hypoglycemia when used in combination with INVOKANA (5.5)
- **Necrotizing fasciitis of the perineum (Fournier's gangrene):** Serious, life-threatening cases have occurred in both females and males. Assess patients presenting with pain or tenderness, erythema, or swelling in the genital or perineal area, along with fever or malaise. If suspected, institute prompt treatment (5.6)
- **Genital mycotic infections:** Monitor and treat if indicated (5.7)
- **Hypersensitivity reactions:** Discontinue INVOKANA and monitor until signs and symptoms resolve (5.8)
- **Bone fracture:** Consider factors that contribute to fracture risk before initiating INVOKANA (5.9)

ADVERSE REACTIONS

- Most common adverse reactions associated with INVOKANA (5% or greater incidence): female genital mycotic infections, urinary tract infection, and increased urination (6.1)

To report SUSPECTED ADVERSE REACTIONS, contact Janssen Pharmaceuticals, Inc. at 1-800-526-7736 or FDA at 1-800-FDA-1088 or www.fda.gov/medwatch.

DRUG INTERACTIONS

- **UGT inducers** (e.g., rifampin): Canagliflozin exposure is reduced. Adjust canagliflozin dose (2.3, 7.1)
- **Digoxin:** Monitor digoxin levels (7.2)

USE IN SPECIFIC POPULATIONS

- **Pregnancy:** Advise females of the potential risk to a fetus especially during the second and third trimesters (8.1)
- **Lactation:** Not recommended when breastfeeding (8.2)
- **Geriatrics:** Higher incidence of adverse reactions related to reduced intravascular volume (5.2, 8.5)
- **Renal impairment:** Higher incidence of adverse reactions related to hypotension and renal function (2.3, 5.2, 8.6)
- **Hepatic impairment:** Not recommended with severe hepatic impairment (8.7)

See 17 for PATIENT COUNSELING INFORMATION and Medication Guide.

Revised: 08/2020

FULL PRESCRIBING INFORMATION: CONTENTS*

1 INDICATIONS AND USAGE

2 DOSAGE AND ADMINISTRATION

- 2.1 Prior to Initiation of INVOKANA
- 2.2 Recommended Dosage
- 2.3 Concomitant Use with UDP-Glucuronosyl Transferase (UGT) Enzyme Inducers

3 DOSAGE FORMS AND STRENGTHS

4 CONTRAINDICATIONS

5 WARNINGS AND PRECAUTIONS

- 5.1 Lower Limb Amputation

5.2 Volume Depletion

5.3 Ketoacidosis

5.4 Urosepsis and Pyelonephritis

5.5 Hypoglycemia with Concomitant Use with Insulin and Insulin Secretagogues

5.6 Necrotizing Fasciitis of the Perineum (Fournier's Gangrene)

5.7 Genital Mycotic Infections

5.8 Hypersensitivity Reactions

5.9 Bone Fracture

6 ADVERSE REACTIONS

6.1 Clinical Studies Experience

- 6.2 Postmarketing Experience
- 7 DRUG INTERACTIONS**
 - 7.1 UGT Enzyme Inducers
 - 7.2 Digoxin
 - 7.3 Positive Urine Glucose Test
 - 7.4 Interference with 1,5-anhydroglucitol (1,5-AG) Assay
- 8 USE IN SPECIFIC POPULATIONS**
 - 8.1 Pregnancy
 - 8.2 Lactation
 - 8.4 Pediatric Use
 - 8.5 Geriatric Use
 - 8.6 Renal Impairment
 - 8.7 Hepatic Impairment
- 10 OVERDOSAGE**
- 11 DESCRIPTION**
- 12 CLINICAL PHARMACOLOGY**
 - 12.1 Mechanism of Action

- 12.2 Pharmacodynamics
- 12.3 Pharmacokinetics
- 13 NONCLINICAL TOXICOLOGY**
 - 13.1 Carcinogenesis, Mutagenesis, Impairment of Fertility
- 14 CLINICAL STUDIES**
 - 14.1 Glycemic Control Trials in Adults with Type 2 Diabetes Mellitus
 - 14.2 Cardiovascular Outcomes in Patients with Type 2 Diabetes Mellitus and Atherosclerotic Cardiovascular Disease
 - 14.3 Renal and Cardiovascular Outcomes in Patients with Diabetic Nephropathy and Albuminuria
- 16 HOW SUPPLIED/STORAGE AND HANDLING**
- 17 PATIENT COUNSELING INFORMATION**

*Sections or subsections omitted from the full prescribing information are not listed.

FULL PRESCRIBING INFORMATION

1 INDICATIONS AND USAGE

INVOKANA (canagliflozin) is indicated:

- as an adjunct to diet and exercise to improve glycemic control in adults with type 2 diabetes mellitus.
- to reduce the risk of major adverse cardiovascular events (cardiovascular death, nonfatal myocardial infarction and nonfatal stroke) in adults with type 2 diabetes mellitus and established cardiovascular disease (CVD).
- to reduce the risk of end-stage kidney disease (ESKD), doubling of serum creatinine, cardiovascular (CV) death, and hospitalization for heart failure in adults with type 2 diabetes mellitus and diabetic nephropathy with albuminuria greater than 300 mg/day.

Limitations of Use

INVOKANA is not recommended in patients with type 1 diabetes mellitus. It may increase the risk of diabetic ketoacidosis in these patients [see *Warnings and Precautions (5.2)*].

INVOKANA is not recommended for use to improve glycemic control in adults with type 2 diabetes mellitus with an eGFR less than 30 mL/min/1.73 m². INVOKANA is likely to be ineffective in this setting based upon its mechanism of action.

2 DOSAGE AND ADMINISTRATION

2.1 Prior to Initiation of INVOKANA

Assess renal function before initiating INVOKANA and as clinically indicated [see *Warnings and Precautions (5.2)*].

In patients with volume depletion, correct this condition before initiating INVOKANA [see *Warnings and Precautions (5.2), Use in Specific Populations (8.5, 8.6)*].

2.2 Recommended Dosage

See Table 1 for dosage recommendations based on estimated glomerular filtration rate (eGFR).

Table 1: Recommended Dosage

estimated glomerular filtration rate eGFR (mL/min/1.73 m ²)	Recommended Dosage
eGFR 60 or greater	100 mg orally once daily, taken before the first meal of the day. Dose can be increased to 300 mg once daily for additional glycemic control.
eGFR 30 to less than 60	100 mg once daily.
eGFR less than 30	Initiation is not recommended, however patients with albuminuria greater than 300 mg/day may continue 100 mg once daily to reduce the risk of ESKD, doubling of serum creatinine, CV death, and hospitalization for heart failure [see <i>Indications and Usage (1), Use in Specific Populations (8.6)</i>].
On dialysis	Contraindicated [see <i>Contraindications (4)</i>].

2.3 Concomitant Use with UDP-Glucuronosyl Transferase (UGT) Enzyme Inducers

Patients with eGFR 60 mL/min/1.73 m² or greater

If an inducer of UGTs (e.g., rifampin, phenytoin, phenobarbital, ritonavir) is co-administered with INVOKANA, increase the dose to 200 mg (taken as two 100 mg tablets) once daily in patients currently tolerating INVOKANA 100 mg. The dose may be increased to 300 mg once daily in patients currently tolerating INVOKANA 200 mg and who require additional glycemic control [see *Drug Interactions (7.1)*].

Patients with eGFR less than 60 mL/min/1.73 m²

If an inducer of UGTs (e.g., rifampin, phenytoin, phenobarbital, ritonavir) is co-administered with INVOKANA, increase the dose to 200 mg (taken as two 100 mg tablets) once daily in patients currently tolerating INVOKANA 100 mg. Consider adding another antihyperglycemic agent in patients who require additional glycemic control.

3 DOSAGE FORMS AND STRENGTHS

- INVOKANA 100 mg tablets are yellow, capsule-shaped, tablets with “CFZ” on one side and “100” on the other side.
- INVOKANA 300 mg tablets are white, capsule-shaped, tablets with “CFZ” on one side and “300” on the other side.

4 CONTRAINDICATIONS

- Serious hypersensitivity reaction to INVOKANA, such as anaphylaxis or angioedema [see *Warnings and Precautions (5.8) and Adverse Reactions (6.1, 6.2)*].

- Patients on dialysis [*see Use in Specific Populations (8.6)*].

5 WARNINGS AND PRECAUTIONS

5.1 Lower Limb Amputation

An increased risk of lower limb amputations associated with INVOKANA use versus placebo was observed in CANVAS (5.9 vs 2.8 events per 1000 patient-years) and CANVAS-R (7.5 vs 4.2 events per 1000 patient-years), two randomized, placebo-controlled trials evaluating patients with type 2 diabetes who had either established cardiovascular disease or were at risk for cardiovascular disease. The risk of lower limb amputations was observed at both the 100 mg and 300 mg once daily dosage regimens. The amputation data for CANVAS and CANVAS-R are shown in Tables 3 and 4, respectively [*see Adverse Reactions (6.1)*].

Amputations of the toe and midfoot (99 out of 140 patients with amputations receiving INVOKANA in the two trials) were the most frequent; however, amputations involving the leg, below and above the knee, were also observed (41 out of 140 patients with amputations receiving INVOKANA in the two trials). Some patients had multiple amputations, some involving both lower limbs.

Lower limb infections, gangrene, and diabetic foot ulcers were the most common precipitating medical events leading to the need for an amputation. The risk of amputation was highest in patients with a baseline history of prior amputation, peripheral vascular disease, and neuropathy.

Before initiating INVOKANA, consider factors in the patient history that may predispose to the need for amputations, such as a history of prior amputation, peripheral vascular disease, neuropathy and diabetic foot ulcers. Counsel patients about the importance of routine preventative foot care. Monitor patients receiving INVOKANA for signs and symptoms of infection (including osteomyelitis), new pain or tenderness, sores or ulcers involving the lower limbs, and discontinue INVOKANA if these complications occur.

5.2 Volume Depletion

INVOKANA can cause intravascular volume contraction which may sometimes manifest as symptomatic hypotension or acute transient changes in creatinine [*see Adverse Reactions (6.1)*]. There have been post-marketing reports of acute kidney injury which are likely related to volume depletion, some requiring hospitalizations and dialysis, in patients with type 2 diabetes mellitus receiving SGLT2 inhibitors, including INVOKANA. Patients with impaired renal function (eGFR less than 60 mL/min/1.73 m²), elderly patients, or patients on loop diuretics may be at increased risk for volume depletion or hypotension. Before initiating INVOKANA in patients with one or more of these characteristics, assess and correct volume status. Monitor for signs and symptoms of volume depletion after initiating therapy.

5.3 Ketoacidosis

Reports of ketoacidosis, a serious life-threatening condition requiring urgent hospitalization have been identified in clinical trials and postmarketing surveillance in patients with type 1 and type 2 diabetes mellitus receiving sodium glucose co-transporter-2 (SGLT2) inhibitors, including INVOKANA. In placebo-controlled trials of patients with type 1 diabetes, the risk of ketoacidosis was increased in patients who received SGLT2 inhibitors compared to patients who received placebo. The risk of ketoacidosis may be greater with higher doses. Fatal cases of ketoacidosis have been reported in patients taking INVOKANA. INVOKANA is not indicated for the treatment of patients with type 1 diabetes mellitus [*see Indications and Usage (1)*].

Patients treated with INVOKANA who present with signs and symptoms consistent with severe metabolic acidosis should be assessed for ketoacidosis regardless of presenting blood glucose levels, as ketoacidosis associated with INVOKANA may be present even if blood glucose levels are less than 250 mg/dL. If ketoacidosis is suspected, INVOKANA should be discontinued, patient should be evaluated, and prompt treatment should be instituted. Treatment of ketoacidosis may require insulin, fluid and carbohydrate replacement.

In many of the postmarketing reports, and particularly in patients with type 1 diabetes, the presence of ketoacidosis was not immediately recognized and institution of treatment was delayed because presenting blood glucose levels were below those typically expected for diabetic ketoacidosis (often less than 250 mg/dL). Signs and symptoms at presentation were consistent with dehydration and severe metabolic acidosis and included nausea, vomiting, abdominal pain, generalized malaise, and shortness of breath. In some but not all cases, factors predisposing to ketoacidosis such as insulin dose reduction, acute febrile illness, reduced caloric intake, surgery, pancreatic disorders suggesting insulin deficiency (e.g., type 1 diabetes, history of pancreatitis or pancreatic surgery), and alcohol abuse were identified.

Before initiating INVOKANA, consider factors in the patient history that may predispose to ketoacidosis including pancreatic insulin deficiency from any cause, caloric restriction, and alcohol abuse.

For patients who undergo scheduled surgery, consider temporarily discontinuing INVOKANA for at least 3 days prior to surgery [*see Clinical Pharmacology (12.2, 12.3)*].

Consider monitoring for ketoacidosis and temporarily discontinuing INVOKANA in other clinical situations known to predispose to ketoacidosis (e.g., prolonged fasting due to acute illness or post-surgery). Ensure risk factors for ketoacidosis are resolved prior to restarting INVOKANA.

Educate patients on the signs and symptoms of ketoacidosis and instruct patients to discontinue INVOKANA and seek medical attention immediately if signs and symptoms occur.

5.4 Urosepsis and Pyelonephritis

There have been postmarketing reports of serious urinary tract infections including urosepsis and pyelonephritis requiring hospitalization in patients receiving SGLT2 inhibitors, including INVOKANA. Treatment with SGLT2 inhibitors increases the risk for urinary tract infections. Evaluate patients for signs and symptoms of urinary tract infections and treat promptly, if indicated [*see Adverse Reactions (6)*].

5.5 Hypoglycemia with Concomitant Use with Insulin and Insulin Secretagogues

Insulin and insulin secretagogues are known to cause hypoglycemia. INVOKANA may increase the risk of hypoglycemia when combined with insulin or an insulin secretagogue [*see Adverse Reactions (6.1)*]. Therefore, a lower dose of insulin or insulin secretagogue may be required to minimize the risk of hypoglycemia when used in combination with INVOKANA.

5.6 Necrotizing Fasciitis of the Perineum (Fournier's Gangrene)

Reports of necrotizing fasciitis of the perineum (Fournier's gangrene), a rare but serious and life-threatening necrotizing infection requiring urgent surgical intervention, have been identified in postmarketing surveillance in patients with diabetes mellitus receiving SGLT2 inhibitors, including INVOKANA. Cases have been reported in both females and males. Serious outcomes have included hospitalization, multiple surgeries, and death.

Patients treated with INVOKANA presenting with pain or tenderness, erythema, or swelling in the genital or perineal area, along with fever or malaise, should be assessed for necrotizing fasciitis. If suspected, start treatment immediately with broad-spectrum antibiotics and, if necessary, surgical debridement. Discontinue INVOKANA, closely monitor blood glucose levels, and provide appropriate alternative therapy for glycemic control.

5.7 Genital Mycotic Infections

INVOKANA increases the risk of genital mycotic infections. Patients with a history of genital mycotic infections and uncircumcised males were more likely to develop genital mycotic infections [*see Adverse Reactions (6.1)*]. Monitor and treat appropriately.

5.8 Hypersensitivity Reactions

Hypersensitivity reactions, including angioedema and anaphylaxis, have been reported with INVOKANA. These reactions generally occurred within hours to days after initiating INVOKANA. If hypersensitivity reactions occur, discontinue use of INVOKANA; treat and

monitor until signs and symptoms resolve [see *Contraindications (4) and Adverse Reactions (6.1, 6.2)*].

5.9 Bone Fracture

An increased risk of bone fracture, occurring as early as 12 weeks after treatment initiation, was observed in patients using INVOKANA in the CANVAS trial [see *Clinical Studies (14.2)*]. Consider factors that contribute to fracture risk prior to initiating INVOKANA [see *Adverse Reactions (6.1)*].

6 ADVERSE REACTIONS

The following important adverse reactions are described below and elsewhere in the labeling:

- Lower Limb Amputation [see *Warnings and Precautions (5.1)*]
- Volume Depletion [see *Warnings and Precautions (5.2)*]
- Ketoacidosis [see *Warnings and Precautions (5.3)*]
- Urosepsis and Pyelonephritis [see *Warnings and Precautions (5.4)*]
- Hypoglycemia with Concomitant Use with Insulin and Insulin Secretagogues [see *Warnings and Precautions (5.5)*]
- Necrotizing Fasciitis of the Perineum (Fournier's gangrene) [see *Warnings and Precautions (5.6)*]
- Genital Mycotic Infections [see *Warnings and Precautions (5.7)*]
- Hypersensitivity Reactions [see *Warnings and Precautions (5.8)*]
- Bone Fracture [see *Warnings and Precautions (5.9)*]

6.1 Clinical Studies Experience

Because clinical trials are conducted under widely varying conditions, adverse reaction rates observed in the clinical trials of a drug cannot be directly compared to the rates in the clinical trials of another drug and may not reflect the rates observed in clinical practice.

Pool of Placebo-Controlled Trials for Glycemic Control

The data in Table 2 is derived from four 26-week placebo-controlled trials where INVOKANA was used as monotherapy in one trial and as add-on therapy in three trials. These data reflect exposure of 1,667 patients to INVOKANA and a mean duration of exposure to INVOKANA of 24 weeks. Patients received INVOKANA 100 mg (N=833), INVOKANA 300 mg (N=834) or placebo (N=646) once daily. The mean age of the population was 56 years and 2% were older than 75 years of age. Fifty percent (50%) of the population was male and 72% were Caucasian, 12% were Asian, and 5% were Black or African American. At baseline the population had diabetes for an average of 7.3 years, had a mean HbA_{1C} of 8.0% and 20% had established

microvascular complications of diabetes. Baseline renal function was normal or mildly impaired (mean eGFR 88 mL/min/1.73 m²).

Table 2 shows common adverse reactions associated with the use of INVOKANA. These adverse reactions were not present at baseline, occurred more commonly on INVOKANA than on placebo, and occurred in at least 2% of patients treated with either INVOKANA 100 mg or INVOKANA 300 mg.

Table 2: Adverse Reactions from Pool of Four 26-Week Placebo-Controlled Studies Reported in ≥ 2% of INVOKANA-Treated Patients*

Adverse Reaction	Placebo N=646	INVOKANA 100 mg N=833	INVOKANA 300 mg N=834
Urinary tract infections [‡]	3.8%	5.9%	4.4%
Increased urination [§]	0.7%	5.1%	4.6%
Thirst [#]	0.1%	2.8%	2.4%
Constipation	0.9%	1.8%	2.4%
Nausea	1.6%	2.1%	2.3%
	N=312	N=425	N=430
Female genital mycotic infections [†]	2.8%	10.6%	11.6%
Vulvovaginal pruritus	0.0%	1.6%	3.2%
	N=334	N=408	N=404
Male genital mycotic infections [¶]	0.7%	4.2%	3.8%

* The four placebo-controlled trials included one monotherapy trial and three add-on combination trials with metformin, metformin and sulfonylurea, or metformin and pioglitazone.

[†] Female genital mycotic infections include the following adverse reactions: Vulvovaginal candidiasis, Vulvovaginal mycotic infection, Vulvovaginitis, Vaginal infection, Vulvitis, and Genital infection fungal.

[‡] Urinary tract infections include the following adverse reactions: Urinary tract infection, Cystitis, Kidney infection, and Urosepsis.

[§] Increased urination includes the following adverse reactions: Polyuria, Pollakiuria, Urine output increased, Micturition urgency, and Nocturia.

[¶] Male genital mycotic infections include the following adverse reactions: Balanitis or Balanoposthitis, Balanitis candida, and Genital infection fungal.

[#] Thirst includes the following adverse reactions: Thirst, Dry mouth, and Polydipsia.

Note: Percentages were weighted by studies. Study weights were proportional to the harmonic mean of the three treatment sample sizes.

Abdominal pain was also more commonly reported in patients taking INVOKANA 100 mg (1.8%), 300 mg (1.7%) than in patients taking placebo (0.8%).

Placebo-Controlled Trial in Diabetic Nephropathy

The occurrence of adverse reactions for INVOKANA was evaluated in patients participating in CREDENCE, a study in patients with type 2 diabetes mellitus and diabetic nephropathy with albuminuria > 300 mg/day [see *Clinical Studies (14.3)*]. These data reflect exposure of 2,201 patients to INVOKANA and a mean duration of exposure to INVOKANA of 137 weeks.

- The rate of lower limb amputations associated with the use of INVOKANA 100 mg relative to placebo was 12.3 vs 11.2 events per 1000 patient-years, respectively, with 2.6 years mean duration of follow-up.

- Incidence rates of adjudicated events of diabetic ketoacidosis (DKA) were 0.21 (0.5%, 12/2,200) and 0.03 (0.1%, 2/2,197) per 100 patient-years of follow-up with INVOKANA 100 mg and placebo, respectively.
- The incidence of hypotension was 2.8% and 1.5% on INVOKANA 100 mg and placebo, respectively.

Pool of Placebo- and Active-Controlled Trials for Glycemic Control and Cardiovascular Outcomes

The occurrence of adverse reactions for INVOKANA was evaluated in patients participating in placebo- and active-controlled trials and in an integrated analysis of two cardiovascular trials, CANVAS and CANVAS-R.

The types and frequency of common adverse reactions observed in the pool of eight clinical trials (which reflect an exposure of 6,177 patients to INVOKANA) were consistent with those listed in Table 2. Percentages were weighted by studies. Study weights were proportional to the harmonic mean of the three treatment sample sizes. In this pool, INVOKANA was also associated with the adverse reactions of fatigue (1.8%, 2.2%, and 2.0% with comparator, INVOKANA 100 mg, and INVOKANA 300 mg, respectively) and loss of strength or energy (i.e., asthenia) (0.6%, 0.7%, and 1.1% with comparator, INVOKANA 100 mg, and INVOKANA 300 mg, respectively).

In the pool of eight clinical trials, the incidence rate of pancreatitis (acute or chronic) was 0.1%, 0.2%, and 0.1% receiving comparator, INVOKANA 100 mg, and INVOKANA 300 mg, respectively.

In the pool of eight clinical trials, hypersensitivity-related adverse reactions (including erythema, rash, pruritus, urticaria, and angioedema) occurred in 3.0%, 3.8%, and 4.2% of patients receiving comparator, INVOKANA 100 mg, and INVOKANA 300 mg, respectively. Five patients experienced serious adverse reactions of hypersensitivity with INVOKANA, which included 4 patients with urticaria and 1 patient with a diffuse rash and urticaria occurring within hours of exposure to INVOKANA. Among these patients, 2 patients discontinued INVOKANA. One patient with urticaria had recurrence when INVOKANA was re-initiated.

Photosensitivity-related adverse reactions (including photosensitivity reaction, polymorphic light eruption, and sunburn) occurred in 0.1%, 0.2%, and 0.2% of patients receiving comparator, INVOKANA 100 mg, and INVOKANA 300 mg, respectively.

Other adverse reactions occurring more frequently on INVOKANA than on comparator were:

Lower Limb Amputation

An increased risk of lower limb amputations associated with INVOKANA use versus placebo was observed in CANVAS (5.9 vs 2.8 events per 1000 patient-years) and CANVAS-R (7.5 vs 4.2 events per 1000 patient-years), two randomized, placebo-controlled trials evaluating patients with type 2 diabetes who had either established cardiovascular disease or were at risk for cardiovascular disease. Patients in CANVAS and CANVAS-R were followed for an average of 5.7 and 2.1 years, respectively [see *Clinical Studies (14.2)*]. The amputation data for CANVAS and CANVAS-R are shown in Tables 3 and 4, respectively.

Table 3: CANVAS Amputations

	Placebo N=1441	INVOKANA 100 mg N=1445	INVOKANA 300 mg N=1441	INVOKANA (Pooled) N=2886
Patients with an amputation, n (%)	22 (1.5)	50 (3.5)	45 (3.1)	95 (3.3)
Total amputations	33	83	79	162
Amputation incidence rate (per 1000 patient-years)	2.8	6.2	5.5	5.9
Hazard Ratio (95% CI)	--	2.24 (1.36, 3.69)	2.01 (1.20, 3.34)	2.12 (1.34, 3.38)

Note: Incidence is based on the number of patients with at least one amputation, and not the total number of amputation events. A patient's follow-up is calculated from Day 1 to the first amputation event date. Some patients had more than one amputation.

Table 4: CANVAS-R Amputations

	Placebo N=2903	INVOKANA 100 mg (with up-titration to 300 mg) N=2904
Patients with an amputation, n (%)	25 (0.9)	45 (1.5)
Total amputations	36	59
Amputation incidence rate (per 1000 patient-years)	4.2	7.5
Hazard Ratio (95% CI)	--	1.80 (1.10, 2.93)

Note: Incidence is based on the number of patients with at least one amputation, and not the total number of amputation events. A patient's follow-up is calculated from Day 1 to the first amputation event date. Some patients had more than one amputation.

Renal Cell Carcinoma

In the CANVAS trial (mean duration of follow-up of 5.7 years) [see *Clinical Studies (14.2)*], the incidence of renal cell carcinoma was 0.15% (2/1331) and 0.29% (8/2716) for placebo and INVOKANA, respectively, excluding patients with less than 6 months of follow-up, less than 90 days of treatment, or a history of renal cell carcinoma. A causal relationship to INVOKANA could not be established due to the limited number of cases.

Volume Depletion-Related Adverse Reactions

INVOKANA results in an osmotic diuresis, which may lead to reductions in intravascular volume. In clinical trials for glycemic control, treatment with INVOKANA was associated with a dose-dependent increase in the incidence of volume depletion-related adverse reactions (e.g., hypotension, postural dizziness, orthostatic hypotension, syncope, and dehydration). An increased incidence was observed in patients on the 300 mg dose. The three factors associated with the largest increase in volume depletion-related adverse reactions in these trials were the use of loop diuretics, moderate renal impairment (eGFR 30 to less than 60 mL/min/1.73 m²), and age 75 years and older (Table 5) [see *Use in Specific Populations* (8.5 and 8.6)].

Table 5: Proportion of Patients With at Least One Volume Depletion-Related Adverse Reaction (Pooled Results from 8 Clinical Trials for Glycemic Control)

Baseline Characteristic	Comparator Group* %	INVOKANA 100 mg %	INVOKANA 300 mg %
Overall population	1.5%	2.3%	3.4%
75 years of age and older [†]	2.6%	4.9%	8.7%
eGFR less than 60 mL/min/1.73 m ^{2†}	2.5%	4.7%	8.1%
Use of loop diuretic [†]	4.7%	3.2%	8.8%

* Includes placebo and active-comparator groups

[†] Patients could have more than 1 of the listed risk factors

Falls

In a pool of nine clinical trials with mean duration of exposure to INVOKANA of 85 weeks, the proportion of patients who experienced falls was 1.3%, 1.5%, and 2.1% with comparator, INVOKANA 100 mg, and INVOKANA 300 mg, respectively. The higher risk of falls for patients treated with INVOKANA was observed within the first few weeks of treatment.

Genital Mycotic Infections

In the pool of four placebo-controlled clinical trials for glycemic control, female genital mycotic infections (e.g., vulvovaginal mycotic infection, vulvovaginal candidiasis, and vulvovaginitis) occurred in 2.8%, 10.6%, and 11.6% of females treated with placebo, INVOKANA 100 mg, and INVOKANA 300 mg, respectively. Patients with a history of genital mycotic infections were more likely to develop genital mycotic infections on INVOKANA. Female patients who developed genital mycotic infections on INVOKANA were more likely to experience recurrence and require treatment with oral or topical antifungal agents and anti-microbial agents. In females, discontinuation due to genital mycotic infections occurred in 0% and 0.7% of patients treated with placebo and INVOKANA, respectively.

In the pool of four placebo-controlled clinical trials, male genital mycotic infections (e.g., candidal balanitis, balanoposthitis) occurred in 0.7%, 4.2%, and 3.8% of males treated with placebo, INVOKANA 100 mg, and INVOKANA 300 mg, respectively. Male genital mycotic

infections occurred more commonly in uncircumcised males and in males with a prior history of balanitis or balanoposthitis. Male patients who developed genital mycotic infections on INVOKANA were more likely to experience recurrent infections (22% on INVOKANA versus none on placebo), and require treatment with oral or topical antifungal agents and anti-microbial agents than patients on comparators. In males, discontinuations due to genital mycotic infections occurred in 0% and 0.5% of patients treated with placebo and INVOKANA, respectively.

In the pooled analysis of 8 randomized trials evaluating glycemic control, phimosis was reported in 0.3% of uncircumcised male patients treated with INVOKANA and 0.2% required circumcision to treat the phimosis.

Hypoglycemia

In all glycemic control trials, hypoglycemia was defined as any event regardless of symptoms, where biochemical hypoglycemia was documented (any glucose value below or equal to 70 mg/dL). Severe hypoglycemia was defined as an event consistent with hypoglycemia where the patient required the assistance of another person to recover, lost consciousness, or experienced a seizure (regardless of whether biochemical documentation of a low glucose value was obtained). In individual clinical trials of glycemic control [see *Clinical Studies (14.1)*], episodes of hypoglycemia occurred at a higher rate when INVOKANA was co-administered with insulin or sulfonylureas (Table 6).

Table 6: Incidence of Hypoglycemia* in Randomized Clinical Studies of Glycemic Control

Monotherapy (26 weeks)	Placebo (N=192)	INVOKANA 100 mg (N=195)	INVOKANA 300 mg (N=197)
Overall [N (%)]	5 (2.6)	7 (3.6)	6 (3.0)
In Combination with Metformin (26 weeks)	Placebo + Metformin (N=183)	INVOKANA 100 mg + Metformin (N=368)	INVOKANA 300 mg + Metformin (N=367)
Overall [N (%)]	3 (1.6)	16 (4.3)	17 (4.6)
Severe [N (%)] [†]	0 (0)	1 (0.3)	1 (0.3)
In Combination with Metformin (52 weeks)	Glimepiride + Metformin (N=482)	INVOKANA 100 mg + Metformin (N=483)	INVOKANA 300 mg + Metformin (N=485)
Overall [N (%)]	165 (34.2)	27 (5.6)	24 (4.9)
Severe [N (%)] [†]	15 (3.1)	2 (0.4)	3 (0.6)
In Combination with Sulfonylurea (18 weeks)	Placebo + Sulfonylurea (N=69)	INVOKANA 100 mg + Sulfonylurea (N=74)	INVOKANA 300 mg + Sulfonylurea (N=72)
Overall [N (%)]	4 (5.8)	3 (4.1)	9 (12.5)
In Combination with Metformin + Sulfonylurea (26 weeks)	Placebo + Metformin + Sulfonylurea (N=156)	INVOKANA 100 mg + Metformin + Sulfonylurea (N=157)	INVOKANA 300 mg + Metformin + Sulfonylurea (N=156)
Overall [N (%)]	24 (15.4)	43 (27.4)	47 (30.1)
Severe [N (%)] [†]	1 (0.6)	1 (0.6)	0
In Combination with	Sitagliptin +		INVOKANA 300 mg +

Metformin + Sulfonylurea (52 weeks)	Metformin + Sulfonylurea (N=378)		Metformin + Sulfonylurea (N=377)
Overall [N (%)]	154 (40.7)		163 (43.2)
Severe [N (%)] [†]	13 (3.4)		15 (4.0)
In Combination with Metformin + Pioglitazone (26 weeks)	Placebo + Metformin + Pioglitazone (N=115)	INVOKANA 100 mg + Metformin + Pioglitazone (N=113)	INVOKANA 300 mg + Metformin + Pioglitazone (N=114)
Overall [N (%)]	3 (2.6)	3 (2.7)	6 (5.3)
In Combination with Insulin (18 weeks)	Placebo (N=565)	INVOKANA 100 mg (N=566)	INVOKANA 300 mg (N=587)
Overall [N (%)]	208 (36.8)	279 (49.3)	285 (48.6)
Severe [N (%)] [†]	14 (2.5)	10 (1.8)	16 (2.7)

* Number of patients experiencing at least one event of hypoglycemia based on either biochemically documented episodes or severe hypoglycemic events in the intent-to-treat population

[†] Severe episodes of hypoglycemia were defined as those where the patient required the assistance of another person to recover, lost consciousness, or experienced a seizure (regardless of whether biochemical documentation of a low glucose value was obtained)

Bone Fracture

In the CANVAS trial [see *Clinical Studies (14.2)*], the incidence rates of all adjudicated bone fracture were 1.09, 1.59, and 1.79 events per 100 patient-years of follow-up to placebo, INVOKANA 100 mg, and INVOKANA 300 mg, respectively. The fracture imbalance was observed within the first 26 weeks of therapy and remained through the end of the trial. Fractures were more likely to be low trauma (e.g., fall from no more than standing height), and affect the distal portion of upper and lower extremities.

Laboratory and Imaging Tests

Increases in Serum Creatinine and Decreases in eGFR

Initiation of INVOKANA causes an increase in serum creatinine and decrease in estimated GFR. In patients with moderate renal impairment, the increase in serum creatinine generally does not exceed 0.2 mg/dL, occurs within the first 6 weeks of starting therapy, and then stabilizes. Increases that do not fit this pattern should prompt further evaluation to exclude the possibility of acute kidney injury [see *Clinical Pharmacology (12.1)*]. The acute effect on eGFR reverses after treatment discontinuation suggesting acute hemodynamic changes may play a role in the renal function changes observed with INVOKANA.

Increases in Serum Potassium

In a pooled population of patients (N=723) in glycemic control trials with moderate renal impairment (eGFR 45 to less than 60 mL/min/1.73 m²), increases in serum potassium to greater than 5.4 mEq/L and 15% above baseline occurred in 5.3%, 5.0%, and 8.8% of patients treated with placebo, INVOKANA 100 mg, and INVOKANA 300 mg, respectively. Severe elevations (greater than or equal to 6.5 mEq/L) occurred in 0.4% of patients treated with placebo, no

patients treated with INVOKANA 100 mg, and 1.3% of patients treated with INVOKANA 300 mg.

In these patients, increases in potassium were more commonly seen in those with elevated potassium at baseline. Among patients with moderate renal impairment, approximately 84% were taking medications that interfere with potassium excretion, such as potassium-sparing diuretics, angiotensin-converting-enzyme inhibitors, and angiotensin-receptor blockers [see *Use in Specific Populations (8.6)*].

In CREDENCE, no difference in serum potassium, no increase in adverse events of hyperkalemia, and no increase in absolute (> 6.5 mEq/L) or relative ($>$ upper limit of normal and $> 15\%$ increase from baseline) increases in serum potassium were observed with INVOKANA 100 mg relative to placebo.

Increases in Low-Density Lipoprotein Cholesterol (LDL-C) and non-High-Density Lipoprotein Cholesterol (non-HDL-C)

In the pool of four glycemic control placebo-controlled trials, dose-related increases in LDL-C with INVOKANA were observed. Mean changes (percent changes) from baseline in LDL-C relative to placebo were 4.4 mg/dL (4.5%) and 8.2 mg/dL (8.0%) with INVOKANA 100 mg and INVOKANA 300 mg, respectively. The mean baseline LDL-C levels were 104 to 110 mg/dL across treatment groups.

Dose-related increases in non-HDL-C with INVOKANA were observed. Mean changes (percent changes) from baseline in non-HDL-C relative to placebo were 2.1 mg/dL (1.5%) and 5.1 mg/dL (3.6%) with INVOKANA 100 mg and 300 mg, respectively. The mean baseline non-HDL-C levels were 140 to 147 mg/dL across treatment groups.

Increases in Hemoglobin

In the pool of four placebo-controlled trials of glycemic control, mean changes (percent changes) from baseline in hemoglobin were -0.18 g/dL (-1.1%) with placebo, 0.47 g/dL (3.5%) with INVOKANA 100 mg, and 0.51 g/dL (3.8%) with INVOKANA 300 mg. The mean baseline hemoglobin value was approximately 14.1 g/dL across treatment groups. At the end of treatment, 0.8%, 4.0%, and 2.7% of patients treated with placebo, INVOKANA 100 mg, and INVOKANA 300 mg, respectively, had hemoglobin above the upper limit of normal.

Decreases in Bone Mineral Density

Bone mineral density (BMD) was measured by dual-energy X-ray absorptiometry in a clinical trial of 714 older adults (mean age 64 years) [see *Clinical Studies (14.1)*]. At 2 years, patients randomized to INVOKANA 100 mg and INVOKANA 300 mg had placebo-corrected declines in BMD at the total hip of 0.9% and 1.2%, respectively, and at the lumbar spine of 0.3% and

0.7%, respectively. Additionally, placebo-adjusted BMD declines were 0.1% at the femoral neck for both INVOKANA doses and 0.4% at the distal forearm for patients randomized to INVOKANA 300 mg. The placebo-adjusted change at the distal forearm for patients randomized to INVOKANA 100 mg was 0%.

6.2 Postmarketing Experience

Additional adverse reactions have been identified during post-approval use of INVOKANA. Because these reactions are reported voluntarily from a population of uncertain size, it is generally not possible to reliably estimate their frequency or establish a causal relationship to drug exposure.

Ketoacidosis

Acute Kidney Injury

Anaphylaxis, Angioedema

Urosepsis and Pyelonephritis

Necrotizing Fasciitis of the Perineum (Fournier's gangrene)

7 DRUG INTERACTIONS

7.1 UGT Enzyme Inducers

Co-administration of canagliflozin with rifampin, a nonselective inducer of several UGT enzymes, including UGT1A9, UGT2B4, decreased canagliflozin area under the curve (AUC) by 51%. This decrease in exposure to canagliflozin may decrease efficacy.

For patients with eGFR 60 mL/min/1.73 m² or greater, if an inducer of UGTs (e.g., rifampin, phenytoin, phenobarbital, ritonavir) is co-administered with INVOKANA, increase the dose to 200 mg (taken as two 100 mg tablets) once daily in patients currently tolerating INVOKANA 100 mg. The dose may be increased to 300 mg once daily in patients currently tolerating INVOKANA 200 mg and who require additional glycemic control.

For patients with eGFR less than 60 mL/min/1.73 m², if an inducer of UGTs (e.g., rifampin, phenytoin, phenobarbital, ritonavir) is co-administered with INVOKANA, increase the dose to 200 mg (taken as two 100 mg tablets) once daily in patients currently tolerating INVOKANA 100 mg. Consider adding another antihyperglycemic agent in patients who require additional glycemic control [*see Dosage and Administration (2.3) and Clinical Pharmacology (12.3)*].

7.2 Digoxin

There was an increase in the AUC and mean peak drug concentration (C_{max}) of digoxin (20% and 36%, respectively) when co-administered with INVOKANA 300 mg [see *Clinical Pharmacology (12.3)*]. Patients taking INVOKANA with concomitant digoxin should be monitored appropriately.

7.3 Positive Urine Glucose Test

Monitoring glycemic control with urine glucose tests is not recommended in patients taking SGLT2 inhibitors as SGLT2 inhibitors increase urinary glucose excretion and will lead to positive urine glucose tests. Use alternative methods to monitor glycemic control.

7.4 Interference with 1,5-anhydroglucitol (1,5-AG) Assay

Monitoring glycemic control with 1,5-AG assay is not recommended as measurements of 1,5-AG are unreliable in assessing glycemic control in patients taking SGLT2 inhibitors. Use alternative methods to monitor glycemic control.

8 USE IN SPECIFIC POPULATIONS

8.1 Pregnancy

Risk Summary

Based on animal data showing adverse renal effects, INVOKANA is not recommended during the second and third trimesters of pregnancy.

Limited data with INVOKANA in pregnant women are not sufficient to determine a drug-associated risk for major birth defects or miscarriage. There are risks to the mother and fetus associated with poorly controlled diabetes in pregnancy [see *Clinical Considerations*].

In animal studies, adverse renal pelvic and tubule dilatations that were not reversible were observed in rats when canagliflozin was administered during a period of renal development corresponding to the late second and third trimesters of human pregnancy, at an exposure 0.5-times the 300 mg clinical dose, based on AUC.

The estimated background risk of major birth defects is 6-10% in women with pre-gestational diabetes with a $HbA_{1C} >7$ and has been reported to be as high as 20-25% in women with a $HbA_{1C} >10$. The estimated background risk of miscarriage for the indicated population is unknown. In the U.S. general population, the estimated background risk of major birth defects and miscarriage in clinically recognized pregnancies is 2-4% and 15-20%, respectively.

Clinical Considerations

Disease-associated maternal and/or embryo/fetal risk

Poorly controlled diabetes in pregnancy increases the maternal risk for diabetic ketoacidosis, pre-eclampsia, spontaneous abortions, preterm delivery, and delivery complications. Poorly controlled diabetes increases the fetal risk for major birth defects, stillbirth, and macrosomia related morbidity.

Animal Data

Canagliflozin dosed directly to juvenile rats from postnatal day (PND) 21 until PND 90 at doses of 4, 20, 65, or 100 mg/kg increased kidney weights and dose dependently increased the incidence and severity of renal pelvic and tubular dilatation at all doses tested. Exposure at the lowest dose was greater than or equal to 0.5-times the 300 mg clinical dose, based on AUC. These outcomes occurred with drug exposure during periods of renal development in rats that correspond to the late second and third trimester of human renal development. The renal pelvic dilatations observed in juvenile animals did not fully reverse within a 1-month recovery period.

In embryo-fetal development studies in rats and rabbits, canagliflozin was administered for intervals coinciding with the first trimester period of organogenesis in humans. No developmental toxicities independent of maternal toxicity were observed when canagliflozin was administered at doses up to 100 mg/kg in pregnant rats and 160 mg/kg in pregnant rabbits during embryonic organogenesis or during a study in which maternal rats were dosed from gestation day (GD) 6 through PND 21, yielding exposures up to approximately 19-times the 300 mg clinical dose, based on AUC.

8.2 Lactation

Risk Summary

There is no information regarding the presence of INVOKANA in human milk, the effects on the breastfed infant, or the effects on milk production. Canagliflozin is present in the milk of lactating rats [*see Data*]. Since human kidney maturation occurs *in utero* and during the first 2 years of life when lactational exposure may occur, there may be risk to the developing human kidney.

Because of the potential for serious adverse reactions in a breastfed infant, advise women that use of INVOKANA is not recommended while breastfeeding.

Data

Animal Data

Radiolabeled canagliflozin administered to lactating rats on day 13 post-partum was present at a milk/plasma ratio of 1.40, indicating that canagliflozin and its metabolites are transferred into

milk at a concentration comparable to that in plasma. Juvenile rats directly exposed to canagliflozin showed a risk to the developing kidney (renal pelvic and tubular dilatations) during maturation.

8.4 Pediatric Use

Safety and effectiveness of INVOKANA in pediatric patients under 18 years of age have not been established.

8.5 Geriatric Use

In 13 clinical trials of INVOKANA, 2,294 patients 65 years and older, and 351 patients 75 years and older were exposed to INVOKANA [see *Clinical Studies (14.1)*].

Patients 65 years and older had a higher incidence of adverse reactions related to reduced intravascular volume with INVOKANA (such as hypotension, postural dizziness, orthostatic hypotension, syncope, and dehydration), particularly with the 300 mg daily dose, compared to younger patients; a more prominent increase in the incidence was seen in patients who were 75 years and older [see *Dosage and Administration (2.1)* and *Adverse Reactions (6.1)*]. Smaller reductions in HbA_{1C} with INVOKANA relative to placebo were seen in older (65 years and older; -0.61% with INVOKANA 100 mg and -0.74% with INVOKANA 300 mg relative to placebo) compared to younger patients (-0.72% with INVOKANA 100 mg and -0.87% with INVOKANA 300 mg relative to placebo).

8.6 Renal Impairment

The efficacy and safety of INVOKANA for glycemic control were evaluated in a trial that included patients with moderate renal impairment (eGFR 30 to less than 50 mL/min/1.73 m²) [see *Clinical Studies (14.1)*]. These patients had less overall glycemic efficacy, and patients treated with 300 mg per day had increases in serum potassium, which were transient and similar by the end of study. Patients with renal impairment using INVOKANA for glycemic control may also be more likely to experience hypotension and may be at higher risk for acute kidney injury [see *Warnings and Precautions (5.2)*].

Efficacy and safety studies with INVOKANA did not enroll patients with ESKD on dialysis or patients with an eGFR less than 30 mL/min/1.73 m². INVOKANA is contraindicated in patients with ESKD on dialysis [see *Contraindications (4)* and *Clinical Pharmacology (12.1)*].

8.7 Hepatic Impairment

No dosage adjustment is necessary in patients with mild or moderate hepatic impairment. The use of INVOKANA has not been studied in patients with severe hepatic impairment and is therefore not recommended [see *Clinical Pharmacology (12.3)*].

10 OVERDOSAGE

In the event of an overdose, contact the Poison Control Center. It is also reasonable to employ the usual supportive measures, e.g., remove unabsorbed material from the gastrointestinal tract, employ clinical monitoring, and institute supportive treatment as dictated by the patient's clinical status. Canagliflozin was negligibly removed during a 4-hour hemodialysis session. Canagliflozin is not expected to be dialyzable by peritoneal dialysis.

11 DESCRIPTION

INVOKANA[®] (canagliflozin) contains canagliflozin, an inhibitor of sodium-glucose co-transporter 2 (SGLT2), the transporter responsible for reabsorbing the majority of glucose filtered by the kidney. Canagliflozin, the active ingredient of INVOKANA, is chemically known as (1*S*)-1,5-anhydro-1-[3-[[5-(4-fluorophenyl)-2-thienyl]methyl]-4-methylphenyl]-D-glucitol hemihydrate and its molecular formula and weight are C₂₄H₂₅FO₅S•1/2 H₂O and 453.53, respectively. The structural formula for canagliflozin is:

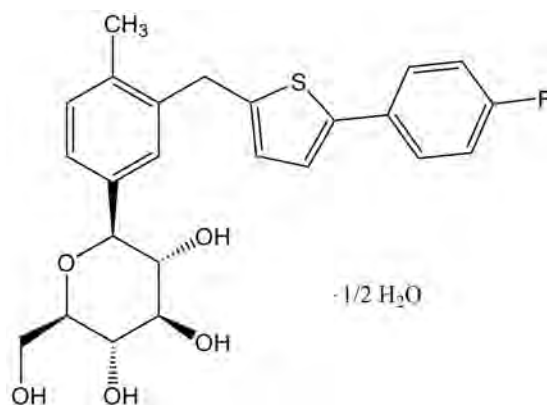

Canagliflozin is practically insoluble in aqueous media from pH 1.1 to 12.9.

INVOKANA is supplied as film-coated tablets for oral administration, containing 102 and 306 mg of canagliflozin in each tablet strength, corresponding to 100 mg and 300 mg of canagliflozin (anhydrous), respectively.

Inactive ingredients of the core tablet are croscarmellose sodium, hydroxypropyl cellulose, lactose anhydrous, magnesium stearate, and microcrystalline cellulose. The magnesium stearate is vegetable-sourced. The tablets are finished with a commercially available film-coating consisting of the following excipients: polyvinyl alcohol (partially hydrolyzed), titanium dioxide, macrogol/PEG, talc, and iron oxide yellow, E172 (100 mg tablet only).

12 CLINICAL PHARMACOLOGY

12.1 Mechanism of Action

Sodium-glucose co-transporter 2 (SGLT2), expressed in the proximal renal tubules, is responsible for the majority of the reabsorption of filtered glucose from the tubular lumen. Canagliflozin is an inhibitor of SGLT2. By inhibiting SGLT2, canagliflozin reduces reabsorption of filtered glucose and lowers the renal threshold for glucose (RT_G), and thereby increases urinary glucose excretion (UGE).

Canagliflozin increases the delivery of sodium to the distal tubule by blocking SGLT2-dependent glucose and sodium reabsorption. This is believed to increase tubuloglomerular feedback and reduce intraglomerular pressure.

12.2 Pharmacodynamics

Following single and multiple oral doses of canagliflozin in patients with type 2 diabetes, dose-dependent decreases in the renal threshold for glucose (RT_G) and increases in urinary glucose excretion were observed. From a starting RT_G value of approximately 240 mg/dL, canagliflozin at 100 mg and 300 mg once daily suppressed RT_G throughout the 24-hour period. Data from single oral doses of canagliflozin in healthy volunteers indicate that, on average, the elevation in urinary glucose excretion approaches baseline by about 3 days for doses up to 300 mg once daily. Maximal suppression of mean RT_G over the 24-hour period was seen with the 300 mg daily dose to approximately 70 to 90 mg/dL in patients with type 2 diabetes in Phase 1 trials. The reductions in RT_G led to increases in mean UGE of approximately 100 g/day in subjects with type 2 diabetes treated with either 100 mg or 300 mg of canagliflozin. In patients with type 2 diabetes given 100 to 300 mg once daily over a 16-day dosing period, reductions in RT_G and increases in urinary glucose excretion were observed over the dosing period. In this trial, plasma glucose declined in a dose-dependent fashion within the first day of dosing. In single-dose trials in healthy and type 2 diabetic subjects, treatment with canagliflozin 300 mg before a mixed-meal delayed intestinal glucose absorption and reduced postprandial glucose.

Cardiac Electrophysiology

In a randomized, double-blind, placebo-controlled, active-comparator, 4-way crossover trial, 60 healthy subjects were administered a single oral dose of canagliflozin 300 mg, canagliflozin 1,200 mg (4 times the maximum recommended dose), moxifloxacin, and placebo. No meaningful changes in QTc interval were observed with either the recommended dose of 300 mg or the 1,200 mg dose.

12.3 Pharmacokinetics

The pharmacokinetics of canagliflozin is similar in healthy subjects and patients with type 2 diabetes. Following single-dose oral administration of 100 mg and 300 mg of INVOKANA, peak plasma concentrations (median T_{max}) of canagliflozin occurs within 1 to 2 hours post-dose. Plasma C_{max} and AUC of canagliflozin increased in a dose-proportional manner from 50 mg to 300 mg. The apparent terminal half-life ($t_{1/2}$) was 10.6 hours and 13.1 hours for the 100 mg and 300 mg doses, respectively. Steady-state was reached after 4 to 5 days of once-daily dosing with canagliflozin 100 mg to 300 mg. Canagliflozin does not exhibit time-dependent pharmacokinetics and accumulated in plasma up to 36% following multiple doses of 100 mg and 300 mg.

Absorption

The mean absolute oral bioavailability of canagliflozin is approximately 65%. Co-administration of a high-fat meal with canagliflozin had no effect on the pharmacokinetics of canagliflozin; therefore, INVOKANA may be taken with or without food. However, based on the potential to reduce postprandial plasma glucose excursions due to delayed intestinal glucose absorption, it is recommended that INVOKANA be taken before the first meal of the day [*see Dosage and Administration (2.2)*].

Distribution

The mean steady-state volume of distribution of canagliflozin following a single intravenous infusion in healthy subjects was 83.5 L, suggesting extensive tissue distribution. Canagliflozin is extensively bound to proteins in plasma (99%), mainly to albumin. Protein binding is independent of canagliflozin plasma concentrations. Plasma protein binding is not meaningfully altered in patients with renal or hepatic impairment.

Metabolism

O-glucuronidation is the major metabolic elimination pathway for canagliflozin, which is mainly glucuronidated by UGT1A9 and UGT2B4 to two inactive *O*-glucuronide metabolites.

CYP3A4-mediated (oxidative) metabolism of canagliflozin is minimal (approximately 7%) in humans.

Excretion

Following administration of a single oral [14 C] canagliflozin dose to healthy subjects, 41.5%, 7.0%, and 3.2% of the administered radioactive dose was recovered in feces as canagliflozin, a hydroxylated metabolite, and an *O*-glucuronide metabolite, respectively. Enterohepatic circulation of canagliflozin was negligible.

Approximately 33% of the administered radioactive dose was excreted in urine, mainly as *O*-glucuronide metabolites (30.5%). Less than 1% of the dose was excreted as unchanged canagliflozin in urine. Renal clearance of canagliflozin 100 mg and 300 mg doses ranged from 1.30 to 1.55 mL/min.

Mean systemic clearance of canagliflozin was approximately 192 mL/min in healthy subjects following intravenous administration.

Specific Populations

Renal Impairment

A single-dose, open-label trial evaluated the pharmacokinetics of canagliflozin 200 mg in subjects with varying degrees of renal impairment (classified using the MDRD-eGFR formula) compared to healthy subjects.

Renal impairment did not affect the C_{\max} of canagliflozin. Compared to healthy subjects (N=3; eGFR greater than or equal to 90 mL/min/1.73 m²), plasma AUC of canagliflozin was increased by approximately 15%, 29%, and 53% in subjects with mild (N=10), moderate (N=9), and severe (N=10) renal impairment, respectively, (eGFR 60 to less than 90, 30 to less than 60, and 15 to less than 30 mL/min/1.73 m², respectively), but was similar for ESKD (N=8) subjects and healthy subjects.

Increases in canagliflozin AUC of this magnitude are not considered clinically relevant. The glucose lowering pharmacodynamic response to canagliflozin declines with increasing severity of renal impairment [see *Contraindications (4) and Warnings and Precautions (5.2)*].

Canagliflozin was negligibly removed by hemodialysis.

Hepatic Impairment

Relative to subjects with normal hepatic function, the geometric mean ratios for C_{\max} and AUC_{∞} of canagliflozin were 107% and 110%, respectively, in subjects with Child-Pugh class A (mild hepatic impairment) and 96% and 111%, respectively, in subjects with Child-Pugh class B (moderate hepatic impairment) following administration of a single 300 mg dose of canagliflozin.

These differences are not considered to be clinically meaningful. There is no clinical experience in patients with Child-Pugh class C (severe) hepatic impairment [see *Use in Specific Populations (8.7)*].

Pharmacokinetic Effects of Age, Body Mass Index (BMI)/Weight, Gender and Race

Based on the population PK analysis with data collected from 1526 subjects, age, body mass index (BMI)/weight, gender, and race do not have a clinically meaningful effect on the pharmacokinetics of canagliflozin [see *Use in Specific Populations (8.5)*].

Drug Interaction Studies

In Vitro Assessment of Drug Interactions

Canagliflozin did not induce CYP450 enzyme expression (3A4, 2C9, 2C19, 2B6, and 1A2) in cultured human hepatocytes. Canagliflozin did not inhibit the CYP450 isoenzymes (1A2, 2A6, 2C19, 2D6, or 2E1) and weakly inhibited CYP2B6, CYP2C8, CYP2C9, and CYP3A4 based on *in vitro* studies with human hepatic microsomes. Canagliflozin is a weak inhibitor of P-gp.

Canagliflozin is also a substrate of drug transporters P-glycoprotein (P-gp) and MRP2.

In Vivo Assessment of Drug Interactions

Table 7: Effect of Co-Administered Drugs on Systemic Exposures of Canagliflozin

Co-Administered Drug	Dose of Co-Administered Drug*	Dose of Canagliflozin*	Geometric Mean Ratio (Ratio With/Without Co-Administered Drug) No Effect = 1.0	
			AUC [†] (90% CI)	C _{max} (90% CI)
See Drug Interactions (7.1) for the clinical relevance of the following:				
Rifampin	600 mg QD for 8 days	300 mg	0.49 (0.44; 0.54)	0.72 (0.61; 0.84)
No dose adjustments of INVOKANA required for the following:				
Cyclosporine	400 mg	300 mg QD for 8 days	1.23 (1.19; 1.27)	1.01 (0.91; 1.11)
Ethinyl estradiol and levonorgestrel	0.03 mg ethinyl estradiol and 0.15 mg levonorgestrel	200 mg QD for 6 days	0.91 (0.88; 0.94)	0.92 (0.84; 0.99)
Hydrochlorothiazide	25 mg QD for 35 days	300 mg QD for 7 days	1.12 (1.08; 1.17)	1.15 (1.06; 1.25)
Metformin	2,000 mg	300 mg QD for 8 days	1.10 (1.05; 1.15)	1.05 (0.96; 1.16)
Probenecid	500 mg BID for 3 days	300 mg QD for 17 days	1.21 (1.16; 1.25)	1.13 (1.00; 1.28)

* Single dose unless otherwise noted

† AUC_{inf} for drugs given as a single dose and AUC_{24h} for drugs given as multiple doses

QD = once daily; BID = twice daily

Table 8: Effect of Canagliflozin on Systemic Exposure of Co-Administered Drugs

Co-Administered Drug	Dose of Co-Administered Drug*	Dose of Canagliflozin*	Geometric Mean Ratio (Ratio With/Without Co-Administered Drug) No Effect = 1.0		
				AUC [†] (90% CI)	C _{max} (90% CI)
See Drug Interactions (7.2) for the clinical relevance of the following:					
Digoxin	0.5 mg QD first day followed by 0.25 mg QD for 6 days	300 mg QD for 7 days	Digoxin	1.20 (1.12; 1.28)	1.36 (1.21; 1.53)
No dose adjustments of co-administered drug required for the following:					
Acetaminophen	1,000 mg	300 mg BID for 25 days	Acetaminophen	1.06 [‡] (0.98; 1.14)	1.00 (0.92; 1.09)
Ethinyl estradiol and levonorgestrel	0.03 mg ethinyl estradiol and 0.15 mg levonorgestrel	200 mg QD for 6 days	ethinyl estradiol	1.07 (0.99; 1.15)	1.22 (1.10; 1.35)
			Levonorgestrel	1.06 (1.00; 1.13)	1.22 (1.11; 1.35)
Glyburide	1.25 mg	200 mg QD for 6 days	Glyburide	1.02 (0.98; 1.07)	0.93 (0.85; 1.01)
			3-cis-hydroxy-glyburide	1.01 (0.96; 1.07)	0.99 (0.91; 1.08)
			4-trans-hydroxy-glyburide	1.03 (0.97; 1.09)	0.96 (0.88; 1.04)
Hydrochlorothiazide	25 mg QD for 35 days	300 mg QD for 7 days	Hydrochlorothiazide	0.99 (0.95; 1.04)	0.94 (0.87; 1.01)
Metformin	2,000 mg	300 mg QD for 8 days	Metformin	1.20 (1.08; 1.34)	1.06 (0.93; 1.20)
Simvastatin	40 mg	300 mg QD for 7 days	Simvastatin	1.12 (0.94; 1.33)	1.09 (0.91; 1.31)
			simvastatin acid	1.18 (1.03; 1.35)	1.26 (1.10; 1.45)
Warfarin	30 mg	300 mg QD for 12 days	(R)-warfarin	1.01 (0.96; 1.06)	1.03 (0.94; 1.13)
			(S)-warfarin	1.06 (1.00; 1.12)	1.01 (0.90; 1.13)
			INR	1.00 (0.98; 1.03)	1.05 (0.99; 1.12)

* Single dose unless otherwise noted

† AUC_{inf} for drugs given as a single dose and AUC_{24h} for drugs given as multiple doses

‡ AUC_{0-12h}

QD = once daily; BID = twice daily; INR = International Normalized Ratio

13 NONCLINICAL TOXICOLOGY

13.1 Carcinogenesis, Mutagenesis, Impairment of Fertility

Carcinogenesis

Carcinogenicity was evaluated in 2-year studies conducted in CD1 mice and Sprague-Dawley rats. Canagliflozin did not increase the incidence of tumors in mice dosed at 10, 30, or 100 mg/kg (less than or equal to 14 times exposure from a 300 mg clinical dose).

Testicular Leydig cell tumors, considered secondary to increased luteinizing hormone (LH), increased significantly in male rats at all doses tested (10, 30, and 100 mg/kg). In a 12-week clinical trial, LH did not increase in males treated with canagliflozin.

Renal tubular adenoma and carcinoma increased significantly in male and female rats dosed at 100 mg/kg, or approximately 12-times exposure from a 300 mg clinical dose. Also, adrenal pheochromocytoma increased significantly in males and numerically in females dosed at 100 mg/kg. Carbohydrate malabsorption associated with high doses of canagliflozin was considered a necessary proximal event in the emergence of renal and adrenal tumors in rats. Clinical trials have not demonstrated carbohydrate malabsorption in humans at canagliflozin doses of up to 2-times the recommended clinical dose of 300 mg.

Mutagenesis

Canagliflozin was not mutagenic with or without metabolic activation in the Ames assay. Canagliflozin was mutagenic in the *in vitro* mouse lymphoma assay with but not without metabolic activation. Canagliflozin was not mutagenic or clastogenic in an *in vivo* oral micronucleus assay in rats and an *in vivo* oral Comet assay in rats.

Impairment of Fertility

Canagliflozin had no effects on the ability of rats to mate and sire or maintain a litter up to the high dose of 100 mg/kg (approximately 14 times and 18 times the 300 mg clinical dose in males and females, respectively), although there were minor alterations in a number of reproductive parameters (decreased sperm velocity, increased number of abnormal sperm, slightly fewer corpora lutea, fewer implantation sites, and smaller litter sizes) at the highest dosage administered.

14 CLINICAL STUDIES

14.1 Glycemic Control Trials in Adults with Type 2 Diabetes Mellitus

INVOKANA (canagliflozin) has been studied as monotherapy, in combination with metformin, sulfonylurea, metformin and sulfonylurea, metformin and sitagliptin, metformin and a thiazolidinedione (i.e., pioglitazone), and in combination with insulin (with or without other anti-hyperglycemic agents). The efficacy of INVOKANA was compared to a dipeptidyl

peptidase-4 (DPP-4) inhibitor (sitagliptin), both as add-on combination therapy with metformin and sulfonylurea, and a sulfonylurea (glimepiride), both as add-on combination therapy with metformin. INVOKANA was also evaluated in adults 55 to 80 years of age and patients with moderate renal impairment.

Monotherapy

A total of 584 patients with type 2 diabetes inadequately controlled on diet and exercise participated in a 26-week double-blind, placebo-controlled trial to evaluate the efficacy and safety of INVOKANA. The mean age was 55 years, 44% of patients were men, and the mean baseline eGFR was 87 mL/min/1.73 m². Patients taking other antihyperglycemic agents (N=281) discontinued the agent and underwent an 8-week washout followed by a 2-week, single-blind, placebo run-in period. Patients not taking oral antihyperglycemic agents (N=303) entered the 2-week, single-blind, placebo run-in period directly. After the placebo run-in period, patients were randomized to INVOKANA 100 mg, INVOKANA 300 mg, or placebo, administered once daily for 26 weeks.

At the end of treatment, INVOKANA 100 mg and 300 mg once daily resulted in a statistically significant improvement in HbA_{1C} (p<0.001 for both doses) compared to placebo. INVOKANA 100 mg and 300 mg once daily also resulted in a greater proportion of patients achieving an HbA_{1C} less than 7%, in significant reduction in fasting plasma glucose (FPG), in improved postprandial glucose (PPG), and in percent body weight reduction compared to placebo (see Table 9). Statistically significant (p<0.001 for both doses) mean changes from baseline in systolic blood pressure relative to placebo were -3.7 mmHg and -5.4 mmHg with INVOKANA 100 mg and 300 mg, respectively.

Table 9: Results from 26-Week Placebo-Controlled Clinical Study with INVOKANA as Monotherapy*

Efficacy Parameter	Placebo (N=192)	INVOKANA 100 mg (N=195)	INVOKANA 300 mg (N=197)
HbA_{1C} (%)			
Baseline (mean)	7.97	8.06	8.01
Change from baseline (adjusted mean)	0.14	-0.77	-1.03
Difference from placebo (adjusted mean) (95% CI) [†]		-0.91 [‡] (-1.09; -0.73)	-1.16 [‡] (-1.34; -0.99)
Percent of Patients Achieving HbA_{1C} < 7%	21	45 [‡]	62 [‡]
Fasting Plasma Glucose (mg/dL)			
Baseline (mean)	166	172	173
Change from baseline (adjusted mean)	8	-27	-35
Difference from placebo (adjusted mean) (95% CI) [†]		-36 [‡] (-42; -29)	-43 [‡] (-50; -37)
2-hour Postprandial Glucose (mg/dL)			
Baseline (mean)	229	250	254
Change from baseline (adjusted mean)	5	-43	-59
Difference from placebo (adjusted mean) (95% CI) [†]		-48 [‡]	-64 [‡]

CI) [†]		(-59.1; -37.0)	(-75.0; -52.9)
Body Weight			
Baseline (mean) in kg	87.5	85.9	86.9
% change from baseline (adjusted mean)	-0.6	-2.8	-3.9
Difference from placebo (adjusted mean) (95% CI) [†]		-2.2 [‡] (-2.9; -1.6)	-3.3 [‡] (-4.0; -2.6)

* Intent-to-treat population using last observation in study prior to glycemic rescue therapy

[†] Least squares mean adjusted for baseline value and stratification factors

[‡] p<0.001

Add-on Combination Therapy with Metformin

A total of 1,284 patients with type 2 diabetes inadequately controlled on metformin monotherapy (greater than or equal to 2,000 mg/day, or at least 1,500 mg/day if higher dose not tolerated) participated in a 26-week, double-blind, placebo- and active-controlled trial to evaluate the efficacy and safety of INVOKANA in combination with metformin. The mean age was 55 years, 47% of patients were men, and the mean baseline eGFR was 89 mL/min/1.73 m². Patients already on the required metformin dose (N=1009) were randomized after completing a 2-week, single-blind, placebo run-in period. Patients taking less than the required metformin dose or patients on metformin in combination with another antihyperglycemic agent (N=275) were switched to metformin monotherapy (at doses described above) for at least 8 weeks before entering the 2-week, single-blind, placebo run-in. After the placebo run-in period, patients were randomized to INVOKANA 100 mg, INVOKANA 300 mg, sitagliptin 100 mg, or placebo, administered once daily as add-on therapy to metformin.

At the end of treatment, INVOKANA 100 mg and 300 mg once daily resulted in a statistically significant improvement in HbA_{1C} (p<0.001 for both doses) compared to placebo when added to metformin. INVOKANA 100 mg and 300 mg once daily also resulted in a greater proportion of patients achieving an HbA_{1C} less than 7%, in significant reduction in fasting plasma glucose (FPG), in improved postprandial glucose (PPG), and in percent body weight reduction compared to placebo when added to metformin (see Table 10). Statistically significant (p<0.001 for both doses) mean changes from baseline in systolic blood pressure relative to placebo were -5.4 mmHg and -6.6 mmHg with INVOKANA 100 mg and 300 mg, respectively.

Table 10: Results from 26-Week Placebo-Controlled Clinical Study of INVOKANA in Combination with Metformin*

Efficacy Parameter	Placebo + Metformin (N=183)	INVOKANA 100 mg + Metformin (N=368)	INVOKANA 300 mg + Metformin (N=367)
HbA_{1C} (%)			
Baseline (mean)	7.96	7.94	7.95
Change from baseline (adjusted mean)	-0.17	-0.79	-0.94
Difference from placebo (adjusted mean) (95% CI)		-0.62 [‡]	-0.77 [‡]

CI) [†]		(-0.76; -0.48)	(-0.91; -0.64)
Percent of patients achieving HbA_{1C} < 7%	30	46 [‡]	58 [‡]
Fasting Plasma Glucose (mg/dL)			
Baseline (mean)	164	169	173
Change from baseline (adjusted mean)	2	-27	-38
Difference from placebo (adjusted mean) (95% CI) [†]		-30 [‡] (-36; -24)	-40 [‡] (-46; -34)
2-hour Postprandial Glucose (mg/dL)			
Baseline (mean)	249	258	262
Change from baseline (adjusted mean)	-10	-48	-57
Difference from placebo (adjusted mean) (95% CI) [†]		-38 [‡] (-49; -27)	-47 [‡] (-58; -36)
Body Weight			
Baseline (mean) in kg	86.7	88.7	85.4
% change from baseline (adjusted mean)	-1.2	-3.7	-4.2
Difference from placebo (adjusted mean) (95% CI) [†]		-2.5 [‡] (-3.1; -1.9)	-2.9 [‡] (-3.5; -2.3)

* Intent-to-treat population using last observation in study prior to glycemic rescue therapy

[†] Least squares mean adjusted for baseline value and stratification factors

[‡] p<0.001

Initial Combination Therapy with Metformin

A total of 1,186 patients with type 2 diabetes inadequately controlled with diet and exercise participated in a 26-week double-blind, active-controlled, parallel-group, 5-arm, multicenter trial to evaluate the efficacy and safety of initial therapy with INVOKANA in combination with metformin XR. The median age was 56 years, 48% of patients were men, and the mean baseline eGFR was 87.6 mL/min/1.73 m². The median duration of diabetes was 1.6 years, and 72% of patients were treatment naïve. After completing a 2-week single-blind placebo run-in period, patients were randomly assigned for a double-blind treatment period of 26 weeks to 1 of 5 treatment groups (Table 11). The metformin XR dose was initiated at 500 mg/day for the first week of treatment and then increased to 1000 mg/day. Metformin XR or matching placebo was up-titrated every 2-3 weeks during the next 8 weeks of treatment to a maximum daily dose of 1500 to 2000 mg/day, as tolerated; about 90% of patients reached 2000 mg/day.

At the end of treatment, INVOKANA 100 mg and INVOKANA 300 mg in combination with metformin XR resulted in a statistically significant greater improvement in HbA_{1C} compared to their respective INVOKANA doses (100 mg and 300 mg) alone or metformin XR alone.

Table 11: Results from 26-Week Active-Controlled Clinical Study of INVOKANA Alone or INVOKANA as Initial Combination Therapy with Metformin*

Efficacy Parameter	Metformin XR (N=237)	INVOKANA 100 mg (N=237)	INVOKANA 300 mg (N=238)	INVOKANA 100 mg + Metformin XR (N=237)	INVOKANA 300 mg + Metformin XR (N=237)
HbA_{1C} (%)					
Baseline (mean)	8.81	8.78	8.77	8.83	8.90

Change from baseline (adjusted mean) [†]	-1.30	-1.37	-1.42	-1.77	-1.78
Difference from canagliflozin 100 mg (adjusted mean) (95% CI) [†]				-0.40 [‡] (-0.59, -0.21)	
Difference from canagliflozin 300 mg (adjusted mean) (95% CI) [†]					-0.36 [‡] (-0.56, -0.17)
Difference from metformin XR (adjusted mean) (95% CI) [†]		-0.06 ^{‡‡} (-0.26, 0.13)	-0.11 ^{‡‡} (-0.31, 0.08)	-0.46 [‡] (-0.66, -0.27)	-0.48 [‡] (-0.67, -0.28)
Percent of patients achieving HbA_{1c} < 7%	38	34	39	47 ^{§§}	51 ^{§§}

* Intent-to-treat population

[†] Least squares mean adjusted for covariates including baseline value and stratification factor

[‡] Adjusted p=0.001 for superiority

^{‡‡} Adjusted p=0.001 for non-inferiority

^{§§} Adjusted p<0.05

[†] There were 121 patients without week 26 efficacy data. Analyses addressing missing data gave consistent results with the results provided in this table.

INVOKANA Compared to Glimepiride, Both as Add-on Combination With Metformin

A total of 1,450 patients with type 2 diabetes inadequately controlled on metformin monotherapy (greater than or equal to 2,000 mg/day, or at least 1,500 mg/day if higher dose not tolerated) participated in a 52-week, double-blind, active-controlled trial to evaluate the efficacy and safety of INVOKANA in combination with metformin.

The mean age was 56 years, 52% of patients were men, and the mean baseline eGFR was 90 mL/min/1.73 m². Patients tolerating maximally required metformin dose (N=928) were randomized after completing a 2-week, single-blind, placebo run-in period. Other patients (N=522) were switched to metformin monotherapy (at doses described above) for at least 10 weeks, then completed a 2-week single-blind run-in period. After the 2-week run-in period, patients were randomized to INVOKANA 100 mg, INVOKANA 300 mg, or glimepiride (titration allowed throughout the 52-week trial to 6 or 8 mg), administered once daily as add-on therapy to metformin.

As shown in Table 12 and Figure 1, at the end of treatment, INVOKANA 100 mg provided similar reductions in HbA_{1c} from baseline compared to glimepiride when added to metformin therapy. INVOKANA 300 mg provided a greater reduction from baseline in HbA_{1c} compared to glimepiride, and the relative treatment difference was -0.12% (95% CI: -0.22; -0.02). As shown in Table 12, treatment with INVOKANA 100 mg and 300 mg daily provided greater improvements in percent body weight change, relative to glimepiride.

Table 12: Results from 52-Week Clinical Study Comparing INVOKANA to Glimepiride in Combination with Metformin*

Efficacy Parameter	INVOKANA 100 mg + Metformin (N=483)	INVOKANA 300 mg + Metformin (N=485)	Glimepiride (titrated) + Metformin (N=482)
HbA_{1c} (%)			
Baseline (mean)	7.78	7.79	7.83
Change from baseline (adjusted mean)	-0.82	-0.93	-0.81
Difference from glimepiride (adjusted mean) (95% CI) [†]	-0.01 [‡] (-0.11; 0.09)	-0.12 [‡] (-0.22; -0.02)	
Percent of patients achieving HbA_{1c} < 7%	54	60	56
Fasting Plasma Glucose (mg/dL)			
Baseline (mean)	165	164	166
Change from baseline (adjusted mean)	-24	-28	-18
Difference from glimepiride (adjusted mean) (95% CI) [†]	-6 (-10; -2)	-9 (-13; -5)	
Body Weight			
Baseline (mean) in kg	86.8	86.6	86.6
% change from baseline (adjusted mean)	-4.2	-4.7	1.0
Difference from glimepiride (adjusted mean) (95% CI) [†]	-5.2 [§] (-5.7; -4.7)	-5.7 [§] (-6.2; -5.1)	

* Intent-to-treat population using last observation in study prior to glycemic rescue therapy

[†] Least squares mean adjusted for baseline value and stratification factors

[‡] INVOKANA + metformin is considered non-inferior to glimepiride + metformin because the upper limit of this confidence interval is less than the pre-specified non-inferiority margin of < 0.3%.

[§] p<0.001

Figure 1: Mean HbA_{1c} Change at Each Time Point (Completers) and at Week 52 Using Last Observation Carried Forward (mITT Population)

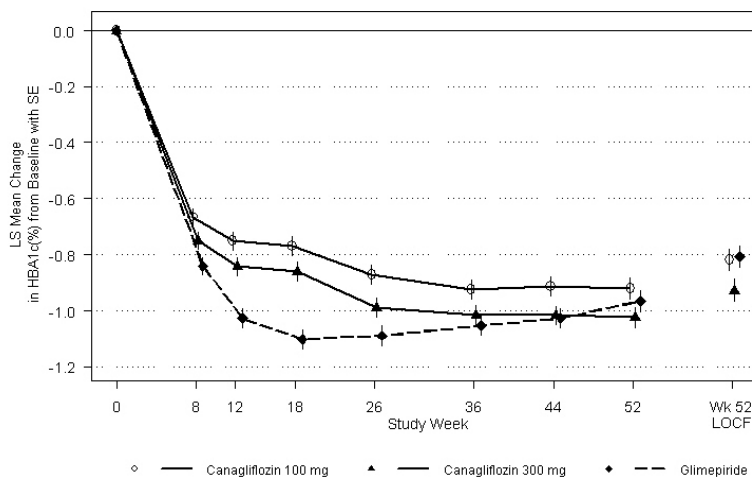

Add-on Combination Therapy with Sulfonylurea

A total of 127 patients with type 2 diabetes inadequately controlled on sulfonylurea monotherapy participated in an 18-week, double-blind, placebo-controlled sub-study to evaluate the efficacy

and safety of INVOKANA in combination with sulfonylurea. The mean age was 65 years, 57% of patients were men, and the mean baseline eGFR was 69 mL/min/1.73 m². Patients treated with sulfonylurea monotherapy on a stable protocol-specified dose (greater than or equal to 50% maximal dose) for at least 10 weeks completed a 2-week, single-blind, placebo run-in period. After the run-in period, patients with inadequate glycemic control were randomized to INVOKANA 100 mg, INVOKANA 300 mg, or placebo, administered once daily as add-on to sulfonylurea.

As shown in Table 13, at the end of treatment, INVOKANA 100 mg and 300 mg daily provided statistically significant (p<0.001 for both doses) improvements in HbA_{1c} relative to placebo when added to sulfonylurea. INVOKANA 300 mg once daily compared to placebo resulted in a greater proportion of patients achieving an HbA_{1c} less than 7%, (33% vs 5%), greater reductions in fasting plasma glucose (-36 mg/dL vs +12 mg/dL), and greater percent body weight reduction (-2.0% vs -0.2%).

Table 13: Results from 18-Week Placebo–Controlled Clinical Study of INVOKANA in Combination with Sulfonylurea*

Efficacy Parameter	Placebo + Sulfonylurea (N=45)	INVOKANA 100 mg + Sulfonylurea (N=42)	INVOKANA 300 mg + Sulfonylurea (N=40)
HbA_{1c} (%)			
Baseline (mean)	8.49	8.29	8.28
Change from baseline (adjusted mean)	0.04	-0.70	-0.79
Difference from placebo (adjusted mean) (95% CI) [†]		-0.74 [‡] (-1.15; -0.33)	-0.83 [‡] (-1.24; -0.41)

* Intent-to-treat population using last observation in study prior to glycemic rescue therapy

[†] Least squares mean adjusted for baseline value

[‡] p<0.001

Add-on Combination Therapy with Metformin and Sulfonylurea

A total of 469 patients with type 2 diabetes inadequately controlled on the combination of metformin (greater than or equal to 2,000 mg/day or at least 1,500 mg/day if higher dose not tolerated) and sulfonylurea (maximal or near-maximal effective dose) participated in a 26-week, double-blind, placebo-controlled trial to evaluate the efficacy and safety of INVOKANA in combination with metformin and sulfonylurea. The mean age was 57 years, 51% of patients were men, and the mean baseline eGFR was 89 mL/min/1.73 m². Patients already on the protocol-specified doses of metformin and sulfonylurea (N=372) entered a 2-week, single-blind, placebo run-in period. Other patients (N=97) were required to be on a stable protocol-specified dose of metformin and sulfonylurea for at least 8 weeks before entering the 2-week run-in period.

Following the run-in period, patients were randomized to INVOKANA 100 mg, INVOKANA 300 mg, or placebo, administered once daily as add-on to metformin and sulfonylurea.

At the end of treatment, INVOKANA 100 mg and 300 mg once daily resulted in a statistically significant improvement in HbA_{1C} (p<0.001 for both doses) compared to placebo when added to metformin and sulfonylurea. INVOKANA 100 mg and 300 mg once daily also resulted in a greater proportion of patients achieving an HbA_{1C} less than 7%, in a significant reduction in fasting plasma glucose (FPG), and in percent body weight reduction compared to placebo when added to metformin and sulfonylurea (see Table 14).

Table 14: Results from 26-Week Placebo-Controlled Clinical Study of INVOKANA in Combination with Metformin and Sulfonylurea*

Efficacy Parameter	Placebo + Metformin and Sulfonylurea (N=156)	INVOKANA 100 mg + Metformin and Sulfonylurea (N=157)	INVOKANA 300 mg + Metformin and Sulfonylurea (N=156)
HbA_{1C} (%)			
Baseline (mean)	8.12	8.13	8.13
Change from baseline (adjusted mean)	-0.13	-0.85	-1.06
Difference from placebo (adjusted mean) (95% CI) [†]		-0.71 [‡] (-0.90; -0.52)	-0.92 [‡] (-1.11; -0.73)
Percent of patients achieving A_{1C} < 7%	18	43 [‡]	57 [‡]
Fasting Plasma Glucose (mg/dL)			
Baseline (mean)	170	173	168
Change from baseline (adjusted mean)	4	-18	-31
Difference from placebo (adjusted mean) (95% CI) [†]		-22 [‡] (-31; -13)	-35 [‡] (-44; -25)
Body Weight			
Baseline (mean) in kg	90.8	93.5	93.5
% change from baseline (adjusted mean)	-0.7	-2.1	-2.6
Difference from placebo (adjusted mean) (95% CI) [†]		-1.4 [‡] (-2.1; -0.7)	-2.0 [‡] (-2.7; -1.3)

* Intent-to-treat population using last observation in study prior to glycemic rescue therapy

[†] Least squares mean adjusted for baseline value and stratification factors

[‡] p<0.001

Add-on Combination Therapy with Metformin and Sitagliptin

A total of 217 patients with type 2 diabetes inadequately controlled on the combination of metformin (greater than or equal to 1,500 mg/day) and sitagliptin 100 mg/day (or equivalent fixed-dose combination) participated in a 26-week, double-blind, placebo-controlled trial to evaluate the efficacy and safety of INVOKANA in combination with metformin and sitagliptin. The mean age was 57 years, 58% of patients were men, 73% of patients were Caucasian, 15% were Asian, and 12% were Black or African-American. The mean baseline eGFR was 90 mL/min/1.73 m² and the mean baseline BMI was 32 kg/m². The mean duration of diabetes

was 10 years. Eligible patients entered a 2-week, single-blind, placebo run-in period and were subsequently randomized to INVOKANA 100 mg or placebo, administered once daily as add-on to metformin and sitagliptin. Patients with a baseline eGFR of 70 mL/min/1.73 m² or greater who were tolerating INVOKANA 100 mg and who required additional glycemic control (fasting finger stick 100 mg/dL or greater at least twice within 2 weeks) were up-titrated to INVOKANA 300 mg. While up-titration occurred as early as Week 4, most (90%) patients randomized to INVOKANA were up-titrated to INVOKANA 300 mg by 6 to 8 weeks.

At the end of 26 weeks, INVOKANA resulted in a statistically significant improvement in HbA_{1c} (p<0.001) compared to placebo when added to metformin and sitagliptin.

Table 15: Results from 26-Week Placebo-Controlled Clinical Study of INVOKANA in Combination with Metformin and Sitagliptin

Efficacy Parameter	Placebo + Metformin and Sitagliptin (N=108*)	INVOKANA + Metformin and Sitagliptin (N=109*)
HbA_{1c} (%)		
Baseline (mean)	8.40	8.50
Change from baseline (adjusted mean)	-0.03	-0.83
Difference from placebo (adjusted mean) (95% CI) ^{†§}		-0.81 [#] (-1.11; -0.51)
Percent of patients achieving HbA_{1c} < 7%[‡]	9	28
Fasting Plasma Glucose (mg/dL)[¶]		
Baseline (mean)	180	185
Change from baseline (adjusted mean)	-3	-28
Difference from placebo (adjusted mean) (95% CI)		-25 [#] (-39; -11)

* To preserve the integrity of randomization, all randomized patients were included in the analysis. The patient who was randomized once to each arm was analyzed on INVOKANA.

† Early treatment discontinuation before week 26, occurred in 11.0% and 24.1% of INVOKANA and placebo patients, respectively.

‡ Patients without week 26 efficacy data were considered as non-responders when estimating the proportion achieving HbA_{1c} < 7%.

§ Estimated using a multiple imputation method modeling a “wash-out” of the treatment effect for patients having missing data who discontinued treatment. Missing data was imputed only at week 26 and analyzed using ANCOVA.

¶ Estimated using a multiple imputation method modeling a “wash-out” of the treatment effect for patients having missing data who discontinued treatment. A mixed model for repeated measures was used to analyze the imputed data.

p<0.001

INVOKANA Compared to Sitagliptin, Both as Add-on Combination Therapy with Metformin and Sulfonylurea

A total of 755 patients with type 2 diabetes inadequately controlled on the combination of metformin (greater than or equal to 2,000 mg/day or at least 1,500 mg/day if higher dose not

tolerated) and sulfonylurea (near-maximal or maximal effective dose) participated in a 52-week, double-blind, active-controlled trial to compare the efficacy and safety of INVOKANA 300 mg versus sitagliptin 100 mg in combination with metformin and sulfonylurea. The mean age was 57 years, 56% of patients were men, and the mean baseline eGFR was 88 mL/min/1.73 m². Patients already on protocol-specified doses of metformin and sulfonylurea (N=716) entered a 2-week single-blind, placebo run-in period. Other patients (N=39) were required to be on a stable protocol-specified dose of metformin and sulfonylurea for at least 8 weeks before entering the 2-week run-in period. Following the run-in period, patients were randomized to INVOKANA 300 mg or sitagliptin 100 mg as add-on to metformin and sulfonylurea.

As shown in Table 16 and Figure 2, at the end of treatment, INVOKANA 300 mg provided greater HbA_{1C} reduction compared to sitagliptin 100 mg when added to metformin and sulfonylurea (p<0.05). INVOKANA 300 mg resulted in a mean percent change in body weight from baseline of -2.5% compared to +0.3% with sitagliptin 100 mg. A mean change in systolic blood pressure from baseline of -5.06 mmHg was observed with INVOKANA 300 mg compared to +0.85 mmHg with sitagliptin 100 mg.

Table 16: Results from 52-Week Clinical Study Comparing INVOKANA to Sitagliptin in Combination with Metformin and Sulfonylurea*

Efficacy Parameter	INVOKANA 300 mg + Metformin and Sulfonylurea (N=377)	Sitagliptin 100 mg + Metformin and Sulfonylurea (N=378)
HbA_{1C} (%)		
Baseline (mean)	8.12	8.13
Change from baseline (adjusted mean)	-1.03	-0.66
Difference from sitagliptin (adjusted mean) (95% CI) [†]	-0.37 [‡] (-0.50; -0.25)	
Percent of patients achieving HbA_{1C} < 7%	48	35
Fasting Plasma Glucose (mg/dL)		
Baseline (mean)	170	164
Change from baseline (adjusted mean)	-30	-6
Difference from sitagliptin (adjusted mean) (95% CI) [†]	-24 (-30; -18)	
Body Weight		
Baseline (mean) in kg	87.6	89.6
% change from baseline (adjusted mean)	-2.5	0.3
Difference from sitagliptin (adjusted mean) (95% CI) [†]	-2.8 [§] (-3.3; -2.2)	

* Intent-to-treat population using last observation in study prior to glycemic rescue therapy

[†] Least squares mean adjusted for baseline value and stratification factors

[‡] INVOKANA + metformin + sulfonylurea is considered non-inferior to sitagliptin + metformin + sulfonylurea because the upper limit of this confidence interval is less than the pre-specified non-inferiority margin of < 0.3%.

[§] p<0.001

Figure 2: Mean HbA_{1c} Change at Each Time Point (Completers) and at Week 52 Using Last Observation Carried Forward (mITT Population)

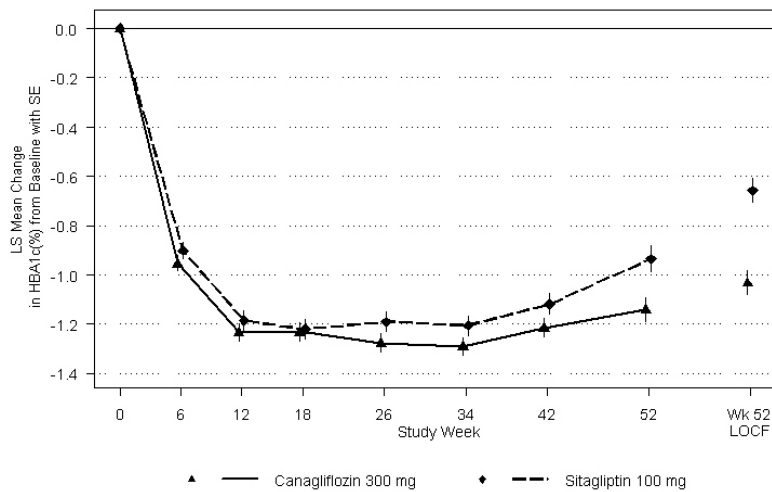

Add-on Combination Therapy with Metformin and Pioglitazone

A total of 342 patients with type 2 diabetes inadequately controlled on the combination of metformin (greater than or equal to 2,000 mg/day or at least 1,500 mg/day if higher dose not tolerated) and pioglitazone (30 or 45 mg/day) participated in a 26-week, double-blind, placebo-controlled trial to evaluate the efficacy and safety of INVOKANA in combination with metformin and pioglitazone. The mean age was 57 years, 63% of patients were men, and the mean baseline eGFR was 86 mL/min/1.73 m². Patients already on protocol-specified doses of metformin and pioglitazone (N=163) entered a 2-week, single-blind, placebo run-in period. Other patients (N=181) were required to be on stable protocol-specified doses of metformin and pioglitazone for at least 8 weeks before entering the 2-week run-in period. Following the run-in period, patients were randomized to INVOKANA 100 mg, INVOKANA 300 mg, or placebo, administered once daily as add-on to metformin and pioglitazone.

At the end of treatment, INVOKANA 100 mg and 300 mg once daily resulted in a statistically significant improvement in HbA_{1c} (p<0.001 for both doses) compared to placebo when added to metformin and pioglitazone. INVOKANA 100 mg and 300 mg once daily also resulted in a greater proportion of patients achieving an HbA_{1c} less than 7%, in significant reduction in fasting plasma glucose (FPG) and in percent body weight reduction compared to placebo when added to metformin and pioglitazone (see Table 17). Statistically significant (p<0.05 for both doses) mean changes from baseline in systolic blood pressure relative to placebo were -4.1 mmHg and -3.5 mmHg with INVOKANA 100 mg and 300 mg, respectively.

Table 17: Results from 26-Week Placebo-Controlled Clinical Study of INVOKANA in Combination with Metformin and Pioglitazone*

Efficacy Parameter	Placebo + Metformin and Pioglitazone (N=115)	INVOKANA 100 mg + Metformin and Pioglitazone (N=113)	INVOKANA 300 mg + Metformin and Pioglitazone (N=114)
HbA_{1C} (%)			
Baseline (mean)	8.00	7.99	7.84
Change from baseline (adjusted mean)	-0.26	-0.89	-1.03
Difference from placebo (adjusted mean) (95% CI) [†]		-0.62 [‡] (-0.81; -0.44)	-0.76 [‡] (-0.95; -0.58)
Percent of patients achieving HbA_{1C} < 7%	33	47 [‡]	64 [‡]
Fasting Plasma Glucose (mg/dL)			
Baseline (mean)	164	169	164
Change from baseline (adjusted mean)	3	-27	-33
Difference from placebo (adjusted mean) (95% CI) [†]		-29 [‡] (-37; -22)	-36 [‡] (-43; -28)
Body Weight			
Baseline (mean) in kg	94.0	94.2	94.4
% change from baseline (adjusted mean)	-0.1	-2.8	-3.8
Difference from placebo (adjusted mean) (95% CI) [†]		-2.7 [‡] (-3.6; -1.8)	-3.7 [‡] (-4.6; -2.8)

* Intent-to-treat population using last observation in study prior to glycemic rescue therapy

[†] Least squares mean adjusted for baseline value and stratification factors

[‡] p<0.001

Add-On Combination Therapy with Insulin (With or Without Other Antihyperglycemic Agents)

A total of 1,718 patients with type 2 diabetes inadequately controlled on insulin greater than or equal to 30 units/day or insulin in combination with other antihyperglycemic agents participated in an 18-week, double-blind, placebo-controlled substudy of a cardiovascular trial to evaluate the efficacy and safety of INVOKANA in combination with insulin. The mean age was 63 years, 66% of patients were men, and the mean baseline eGFR was 75 mL/min/1.73 m². Patients on basal, bolus, or basal/bolus insulin for at least 10 weeks entered a 2-week, single-blind, placebo run-in period. Approximately 70% of patients were on a background basal/bolus insulin regimen. After the run-in period, patients were randomized to INVOKANA 100 mg, INVOKANA 300 mg, or placebo, administered once daily as add-on to insulin. The mean daily insulin dose at baseline was 83 units, which was similar across treatment groups.

At the end of treatment, INVOKANA 100 mg and 300 mg once daily resulted in a statistically significant improvement in HbA_{1C} (p<0.001 for both doses) compared to placebo when added to insulin. INVOKANA 100 mg and 300 mg once daily also resulted in a greater proportion of patients achieving an HbA_{1C} less than 7%, in significant reductions in fasting plasma glucose (FPG), and in percent body weight reductions compared to placebo (see Table 18). Statistically

significant ($p < 0.001$ for both doses) mean changes from baseline in systolic blood pressure relative to placebo were -2.6 mmHg and -4.4 mmHg with INVOKANA 100 mg and 300 mg, respectively.

Table 18: Results from 18-Week Placebo-Controlled Clinical Study of INVOKANA in Combination with Insulin ≥ 30 Units/Day (With or Without Other Oral Antihyperglycemic Agents)*

Efficacy Parameter	Placebo + Insulin (N=565)	INVOKANA 100 mg + Insulin (N=566)	INVOKANA 300 mg + Insulin (N=587)
HbA_{1C} (%)			
Baseline (mean)	8.20	8.33	8.27
Change from baseline (adjusted mean)	0.01	-0.63	-0.72
Difference from placebo (adjusted mean) (95% CI) [†]		-0.65 [‡] (-0.73; -0.56)	-0.73 [‡] (-0.82; -0.65)
Percent of patients achieving HbA_{1C} < 7%	8	20 [‡]	25 [‡]
Fasting Plasma Glucose (mg/dL)			
Baseline	169	170	168
Change from baseline (adjusted mean)	4	-19	-25
Difference from placebo (adjusted mean) (97.5% CI) [†]		-23 [‡] (-29; -16)	-29 [‡] (-35; -23)
Body Weight			
Baseline (mean) in kg	97.7	96.9	96.7
% change from baseline (adjusted mean)	0.1	-1.8	-2.3
Difference from placebo (adjusted mean) (97.5% CI) [†]		-1.9 [‡] (-2.2; -1.6)	-2.4 [‡] (-2.7; -2.1)

* Intent-to-treat population using last observation in study prior to glycemic rescue therapy

[†] Least squares mean adjusted for baseline value and stratification factors

[‡] $p < 0.001$

Study in Patients Ages 55 to 80

A total of 714 type 2 diabetes patients ages 55 to 80 years and inadequately controlled on current diabetes therapy (either diet and exercise alone or in combination with oral or parenteral agents) participated in a 26-week, double-blind, placebo-controlled trial to evaluate the efficacy and safety of INVOKANA in combination with current diabetes treatment. The mean age was 64 years, 55% of patients were men, and the mean baseline eGFR was 77 mL/min/1.73 m². Patients were randomized in a 1:1:1 ratio to the addition of INVOKANA 100 mg, INVOKANA 300 mg, or placebo, administered once daily. At the end of treatment, INVOKANA provided statistically significant improvements from baseline relative to placebo in HbA_{1C} ($p < 0.001$ for both doses) of -0.57% (95% CI: -0.71%; -0.44%) for INVOKANA 100 mg and -0.70% (95% CI: -0.84%; -0.57%) for INVOKANA 300 mg. [see Use in Specific Populations (8.5)].

Glycemic Control in Patients with Moderate Renal Impairment

A total of 269 patients with type 2 diabetes and a baseline eGFR of 30 mL/min/1.73 m² to less than 50 mL/min/1.73 m² inadequately controlled on current diabetes therapy participated in a

26-week, double-blind, placebo-controlled clinical trial to evaluate the efficacy and safety of INVOKANA in combination with current diabetes treatment (diet or antihyperglycemic agent therapy, with 95% of patients on insulin and/or sulfonylurea). The mean age was 68 years, 61% of patients were men, and the mean baseline eGFR was 39 mL/min/1.73 m². Patients were randomized in a 1:1:1 ratio to the addition of INVOKANA 100 mg, INVOKANA 300 mg, or placebo, administered once daily.

At the end of treatment, INVOKANA 100 mg and INVOKANA 300 mg daily provided greater reductions in HbA_{1c} relative to placebo (-0.30% [95% CI: -0.53%; -0.07%] and -0.40%, [95% CI: -0.64%; -0.17%], respectively) [see *Warnings and Precautions* (5.2), *Adverse Reactions* (6.1), *Use in Specific Populations* (8.6), and *Clinical Studies* (14.3)].

14.2 Cardiovascular Outcomes in Patients with Type 2 Diabetes Mellitus and Atherosclerotic Cardiovascular Disease

The CANVAS and CANVAS-R trials were multicenter, multi-national, randomized, double-blind parallel group, with similar inclusion and exclusion criteria. Patients eligible for enrollment in both CANVAS and CANVAS-R trials were: 30 years of age or older and had established, stable, cardiovascular, cerebrovascular, peripheral artery disease (66% of the enrolled population) or were 50 years of age or older and had two or more other specified risk factors for cardiovascular disease (34% of the enrolled population).

The integrated analysis of the CANVAS and CANVAS-R trials compared the risk of Major Adverse Cardiovascular Event (MACE) between canagliflozin and placebo when these were added to and used concomitantly with standard of care treatments for diabetes and atherosclerotic cardiovascular disease. The primary endpoint, MACE, was the time to first occurrence of a three-part composite outcome which included cardiovascular death, non-fatal myocardial infarction and non-fatal stroke.

In CANVAS, patients were randomly assigned 1:1:1 to canagliflozin 100 mg, canagliflozin 300 mg, or matching placebo. In CANVAS-R, patients were randomly assigned 1:1 to canagliflozin 100 mg or matching placebo, and titration to 300 mg was permitted at the investigator's discretion (based on tolerability and glycemic needs) after Week 13. Concomitant antidiabetic and atherosclerotic therapies could be adjusted, at the discretion of investigators, to ensure participants were treated according to the standard care for these diseases.

A total of 10,134 patients were treated (4,327 in CANVAS and 5,807 in CANVAS-R; total of 4,344 randomly assigned to placebo and 5,790 to canagliflozin) for a mean exposure duration of 149 weeks (223 weeks [4.3 years] in CANVAS and 94 weeks [1.8 years] in CANVAS-R).

Approximately 78% of the trial population was Caucasian, 13% was Asian, and 3% was Black. The mean age was 63 years and approximately 64% were male.

The mean HbA_{1C} at baseline was 8.2% and mean duration of diabetes was 13.5 years with 70% of patients having had diabetes for 10 years or more. Approximately 31%, 21% and 17% reported a past history of neuropathy, retinopathy and nephropathy, respectively, and the mean eGFR 76 mL/min/1.73 m². At baseline, patients were treated with one (19%) or more (80%) antidiabetic medications including metformin (77%), insulin (50%), and sulfonylurea (43%).

At baseline, the mean systolic blood pressure was 137 mmHg, the mean diastolic blood pressure was 78 mmHg, the mean LDL was 89 mg/dL, the mean HDL was 46 mg/dL, and the mean urinary albumin to creatinine ratio (UACR) was 115 mg/g. At baseline, approximately 80% of patients were treated with renin angiotensin system inhibitors, 53% with beta-blockers, 13% with loop diuretics, 36% with non-loop diuretics, 75% with statins, and 74% with antiplatelet agents (mostly aspirin). During the trial, investigators could modify anti-diabetic and cardiovascular therapies to achieve local standard of care treatment targets with respect to blood glucose, lipid, and blood pressure. More patients receiving canagliflozin compared to placebo initiated anti-thrombotics (5.2% vs 4.2%) and statins (5.8% vs 4.8%) during the trial.

For the primary analysis, a stratified Cox proportional hazards model was used to test for non-inferiority against a pre-specified risk margin of 1.3 for the hazard ratio of MACE.

In the integrated analysis of CANVAS and CANVAS-R trials, canagliflozin reduced the risk of first occurrence of MACE. The estimated hazard ratio (95% CI) for time to first MACE was 0.86 (0.75, 0.97). Refer to Table 19. Vital status was obtained for 99.6% of patients across the trials. The Kaplan-Meier curve depicting time to first occurrence of MACE is shown in Figure 3.

Table 19: Treatment Effect for the Primary Composite Endpoint, MACE, and its Components in the Integrated Analysis of CANVAS and CANVAS-R studies*

	Placebo N=4347(%)	Canagliflozin N=5795 (%)	Hazard ratio (95% C.I.) [†]
Composite of cardiovascular death, non-fatal myocardial infarction, non-fatal stroke (time to first occurrence) ^{‡, §}	426 (10.4)	585 (9.2)	0.86 (0.75, 0.97)
Non-fatal myocardial infarction ^{‡, §}	159 (3.9)	215 (3.4)	0.85 (0.69, 1.05)
Non-fatal Stroke ^{‡, §}	116 (2.8)	158 (2.5)	0.90 (0.71, 1.15)
Cardiovascular Death ^{‡, §}	185 (4.6)	268 (4.1)	0.87 (0.72, 1.06)

* Intent-To-Treat Analysis Set

† P-value for superiority (2-sided) = 0.0158

‡ Number and percentage of first events

§ Due to pooling of unequal randomization ratios, Cochran-Mantel-Haenszel weights were applied to calculate percentages

† Stratified Cox-proportional hazards model with treatment as a factor and stratified by study and by prior CV disease

Figure 3: Time to First Occurrence of MACE

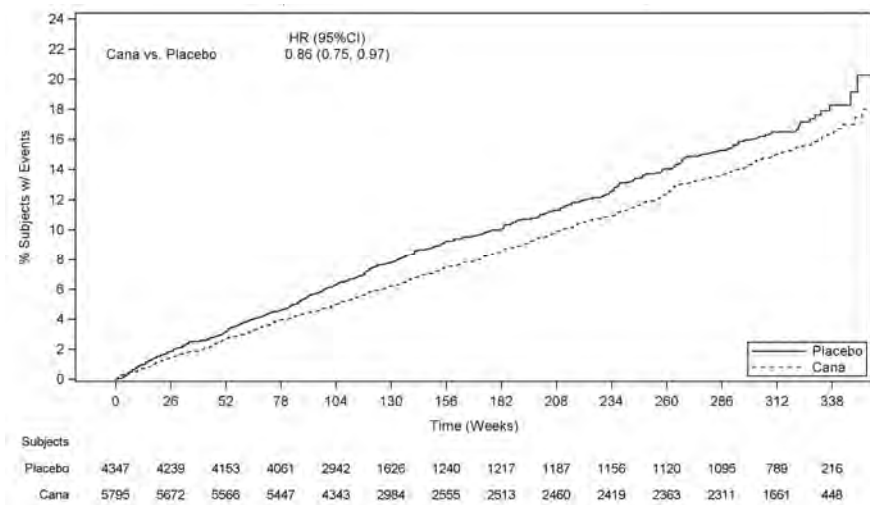

14.3 Renal and Cardiovascular Outcomes in Patients with Diabetic Nephropathy and Albuminuria

The Canagliflozin and Renal Events in Diabetes with Established Nephropathy Clinical Evaluation Trial (CREDENCE) was a multinational, randomized, double-blind, placebo-controlled trial comparing canagliflozin with placebo in patients with type 2 diabetes mellitus, an eGFR ≥ 30 to < 90 mL/min/1.73 m² and albuminuria (urine albumin/creatinine > 300 to ≤ 5000 mg/g) who were receiving standard of care including a maximum-tolerated, labeled daily dose of an angiotensin-converting enzyme inhibitor (ACEi) or angiotensin receptor blocker (ARB).

The primary objective of CREDENCE was to assess the efficacy of canagliflozin relative to placebo in reducing the composite endpoint of end stage kidney disease (ESKD), doubling of serum creatinine, and renal or CV death.

Patients were randomized to receive canagliflozin 100 mg (N=2,202) or placebo (N=2,199) and treatment was continued until the initiation of dialysis or renal transplantation.

The median follow-up duration for the 4,401 randomized subjects was 137 weeks. Vital status was obtained for 99.9% of subjects.

The population was 67% White, 20% Asian, and 5% Black; 32% were of Hispanic or Latino ethnicity. The mean age was 63 years and 66% were male.

At randomization, the mean HbA_{1c} was 8.3%, the median urine albumin/creatinine was 927 mg/g, the mean eGFR was 56.2 mL/min/1.73 m², 50% had prior CV disease, and 15% reported a history of heart failure. The most frequent antihyperglycemic agents (AHA) medications used at baseline were insulin (66%), biguanides (58%), and sulfonylureas (29%). Nearly all subjects (99.9%) were on ACEi or ARB at randomization, approximately 60% were taking an anti-thrombotic agent (including aspirin), and 69% were on a statin.

The primary composite endpoint in the CREDENCE study was the time to first occurrence of ESKD (defined as an eGFR < 15 mL/min/1.73 m², initiation of chronic dialysis or renal transplant), doubling of serum creatinine, and renal or CV death. Canagliflozin 100 mg significantly reduced the risk of the primary composite endpoint based on a time-to-event analysis [HR: 0.70; 95% CI: 0.59, 0.82; p<0.0001] (see Figure 4). The treatment effect reflected a reduction in progression to ESKD, doubling of serum creatinine and cardiovascular death as shown in Table 20 and Figure 4. There were few renal deaths during the trial. Canagliflozin 100 mg also significantly reduced the risk of hospitalization for heart failure [HR: 0.61; 95% CI: 0.47 to 0.80; p<0.001].

Table 20: Analysis of Primary Endpoint (including the Individual Components) and Secondary Endpoints from the CREDENCE Study

Endpoint	Placebo		canagliflozin		HR [†] (95% CI)
	N=2,199 (%)	Event Rate*	N=2,202 (%)	Event Rate*	
Primary Composite Endpoint (ESKD, doubling of serum creatinine, renal death, or CV death)	340 (15.5)	6.1	245 (11.1)	4.3	0.70 (0.59, 0.82) ‡
ESKD	165 (7.5)	2.9	116 (5.3)	2.0	0.68 (0.54, 0.86)
Doubling of serum creatinine	188 (8.5)	3.4	118 (5.4)	2.1	0.60 (0.48, 0.76)
Renal death	5 (0.2)	0.1	2 (0.1)	0.0	
CV death	140 (6.4)	2.4	110 (5.0)	1.9	0.78 (0.61, 1.00)
CV death or hospitalization for heart failure	253 (11.5)	4.5	179 (8.1)	3.1	0.69 (0.57, 0.83) §
CV death, non-fatal myocardial infarction or non-fatal stroke	269 (12.2)	4.9	217 (9.9)	3.9	0.80 (0.67, 0.95) ¶
Non-fatal myocardial infarction	87 (4.0)	1.6	71 (3.2)	1.3	0.81 (0.59, 1.10)
Non-fatal stroke	66 (3.0)	1.2	53 (2.4)	0.9	0.80 (0.56, 1.15)
Hospitalization for heart failure	141 (6.4)	2.5	89 (4.0)	1.6	0.61 (0.47, 0.80) §
ESKD, doubling of serum creatinine or renal death	224 (10.2)	4.0	153 (6.9)	2.7	0.66 (0.53, 0.81) ‡

Intent-To-Treat Analysis Set (time to first occurrence)

The individual components do not represent a breakdown of the composite outcomes, but rather the total number of subjects experiencing an event during the course of the study.

* Event rate per 100 patient-years.

† Hazard ratio (canagliflozin compared to placebo), 95% CI and p-value are estimated using a stratified Cox proportional hazards model including treatment as the explanatory variable and stratified by screening eGFR (≥ 30 to < 45 , ≥ 45 to < 60 , ≥ 60 to < 90 mL/min/1.73 m²). HR is not presented for renal death due to the small number of events in each group.

‡ P-value < 0.0001

§ P-value < 0.001

¶ P-value < 0.02

The Kaplan-Meier curve (Figure 4) shows time to first occurrence of the primary composite endpoint of ESKD, doubling of serum creatinine, renal death, or CV death. The curves begin to separate by Week 52 and continue to diverge thereafter.

Figure 4: CREDENCE: Time to First Occurrence of the Primary Composite Endpoint

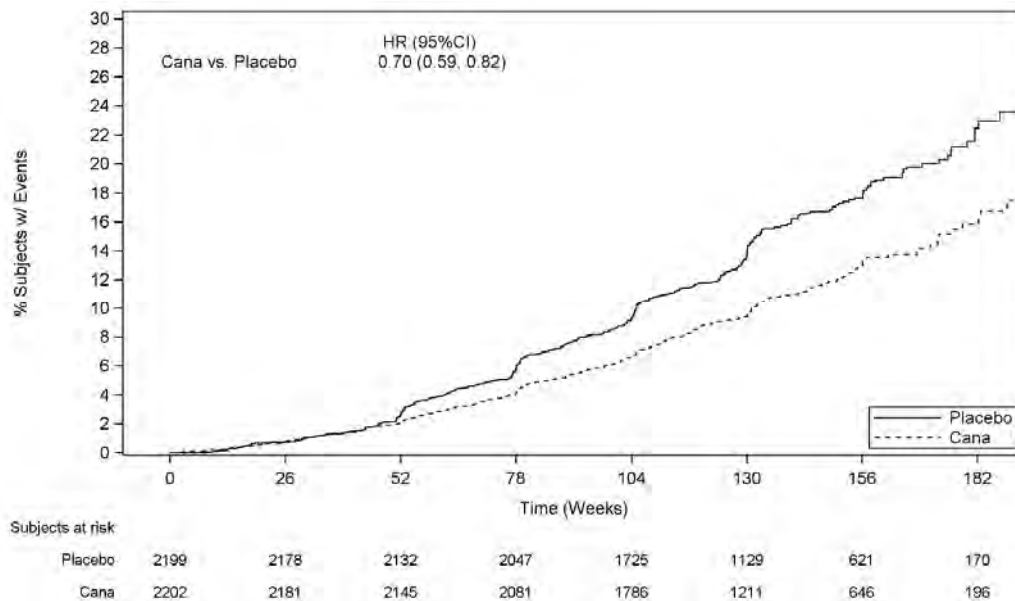

16 HOW SUPPLIED/STORAGE AND HANDLING

INVOKANA® (canagliflozin) tablets are available in the strengths and packages listed below:

100 mg tablets are yellow, capsule-shaped, film-coated tablets with “CFZ” on one side and “100” on the other side.

NDC 50458-140-30	Bottle of 30
NDC 50458-140-90	Bottle of 90
NDC 50458-140-50	Bottle of 500

300 mg tablets are white, capsule-shaped, film-coated tablets with “CFZ” on one side and “300” on the other side.

NDC 50458-141-30	Bottle of 30
NDC 50458-141-90	Bottle of 90
NDC 50458-141-50	Bottle of 500

Storage and Handling

Store at 20°C to 25°C (68°F to 77°F); excursions permitted between 15°C to 30°C (59°F to 86°F) [see USP Controlled Room Temperature].

17 PATIENT COUNSELING INFORMATION

See FDA-approved patient labeling (Medication Guide).

Lower Limb Amputation

Inform patients that INVOKANA is associated with an increased risk of amputations. Counsel patients about the importance of routine preventative foot care. Instruct patients to monitor for

new pain or tenderness, sores or ulcers, or infections involving the leg or foot and to seek medical advice immediately if such signs or symptoms develop [see *Warnings and Precautions (5.1)*].

Volume Depletion

Inform patients that symptomatic hypotension may occur with INVOKANA and advise them to contact their doctor if they experience such symptoms [see *Warnings and Precautions (5.2)*]. Inform patients that dehydration may increase the risk for hypotension, and to have adequate fluid intake.

Ketoacidosis

Inform patients that ketoacidosis is a serious life-threatening condition and that cases of ketoacidosis have been reported during use of INVOKANA, sometimes associated with illness or surgery among other risk factors. Instruct patients to check ketones (when possible) if symptoms consistent with ketoacidosis occur even if blood glucose is not elevated. If symptoms of ketoacidosis (including nausea, vomiting, abdominal pain, tiredness, and labored breathing) occur, instruct patients to discontinue INVOKANA and seek medical attention immediately [see *Warnings and Precautions (5.3)*].

Serious Urinary Tract Infections

Inform patients of the potential for urinary tract infections, which may be serious. Provide them with information on the symptoms of urinary tract infections. Advise them to seek medical advice if such symptoms occur [see *Warnings and Precautions (5.4)*].

Necrotizing Fasciitis of the Perineum (Fournier's Gangrene)

Inform patients that necrotizing infections of the perineum (Fournier's gangrene) have occurred with INVOKANA. Counsel patients to promptly seek medical attention if they develop pain or tenderness, redness, or swelling of the genitals or the area from the genitals back to the rectum, along with a fever above 100.4°F or malaise [see *Warnings and Precautions (5.6)*].

Genital Mycotic Infections in Females (e.g., Vulvovaginitis)

Inform female patients that vaginal yeast infection may occur and provide them with information on the signs and symptoms of vaginal yeast infection. Advise them of treatment options and when to seek medical advice [see *Warnings and Precautions (5.7)*].

Genital Mycotic Infections in Males (e.g., Balanitis or Balanoposthitis)

Inform male patients that yeast infection of penis (e.g., balanitis or balanoposthitis) may occur, especially in uncircumcised males and patients with prior history. Provide them with information on the signs and symptoms of balanitis and balanoposthitis (rash or redness of the glans or

foreskin of the penis). Advise them of treatment options and when to seek medical advice [*see Warnings and Precautions (5.7)*].

Hypersensitivity Reactions

Inform patients that serious hypersensitivity reactions, such as urticaria, rash, anaphylaxis, and angioedema, have been reported with INVOKANA. Advise patients to report immediately any signs or symptoms suggesting allergic reaction, and to discontinue drug until they have consulted prescribing physicians [*see Warnings and Precautions (5.8)*].

Bone Fracture

Inform patients that bone fractures have been reported in patients taking INVOKANA. Provide them with information on factors that may contribute to fracture risk [*see Warnings and Precautions (5.9)*].

Pregnancy

Advise pregnant women, and females of reproductive potential of the potential risk to a fetus with treatment with INVOKANA [*see Use in Specific Populations (8.1)*]. Instruct females of reproductive potential to report pregnancies to their physicians as soon as possible.

Lactation

Advise women that breastfeeding is not recommended during treatment with INVOKANA [*see Use in Specific Populations (8.2)*].

Laboratory Tests

Inform patients that due to its mechanism of action, patients taking INVOKANA will test positive for glucose in their urine [*see Drug Interactions (7.3)*].

Missed Dose

If a dose is missed, advise patients to take it as soon as it is remembered unless it is almost time for the next dose, in which case patients should skip the missed dose and take the medicine at the next regularly scheduled time. Advise patients not to take two doses of INVOKANA at the same time.

Active ingredient made in Belgium

Manufactured for:

Janssen Pharmaceuticals, Inc.

Titusville, NJ 08560

Licensed from Mitsubishi Tanabe Pharma Corporation

© 2013 - 2019 Janssen Pharmaceutical Companies

Medication Guide
INVOKANA® (in-vo-KAHN-uh)
(canagliflozin)
tablets, for oral use

What is the most important information I should know about INVOKANA?

INVOKANA can cause serious side effects, including:

- **Amputations.** INVOKANA may increase your risk of lower limb amputations. Amputations mainly involve removal of the toe or part of the foot, however, amputations involving the leg, below and above the knee, have also occurred. Some people had more than one amputation, some on both sides of the body.

You may be at a higher risk of lower limb amputation if you:

- have a history of amputation
- have heart disease or are at risk for heart disease
- have had blocked or narrowed blood vessels, usually in your leg
- have damage to the nerves (neuropathy) in your leg
- have had diabetic foot ulcers or sores

Call your doctor right away if you have new pain or tenderness, any sores, ulcers, or infections in your leg or foot. Your doctor may decide to stop your INVOKANA for a while if you have any of these signs or symptoms.

Talk to your doctor about proper foot care.

- **Dehydration.** INVOKANA can cause some people to become dehydrated (the loss of too much body water). Dehydration may cause you to feel dizzy, faint, lightheaded, or weak, especially when you stand up (orthostatic hypotension). There have been reports of sudden worsening of kidney function in people with **type 2 diabetes who are taking INVOKANA.**

You may be at higher risk of dehydration if you:

- take medicines to lower your blood pressure, including diuretics (water pill)
- are on a low sodium (salt) diet
- have kidney problems
- are 65 years of age or older

Talk to your doctor about what you can do to prevent dehydration including how much fluid you should drink on a daily basis. Call your healthcare provider right away if you reduce the amount of food or liquid you drink, for example if you cannot eat or you start to lose liquids from your body, for example from vomiting, diarrhea, or being in the sun too long.

- **Ketoacidosis (increased ketones in your blood or urine).** Ketoacidosis has happened in people who have **type 1 diabetes or type 2 diabetes**, during treatment with INVOKANA. Ketoacidosis has also happened in people with diabetes who were sick or who had surgery during treatment with INVOKANA. Ketoacidosis is a serious condition, which may need to be treated in a hospital. Ketoacidosis may lead to death. **Ketoacidosis can happen with INVOKANA even if your blood sugar is less than 250 mg/dL. Stop taking INVOKANA and call your doctor right away if you get any of the following symptoms:**

- nausea
- vomiting
- stomach area (abdominal) pain
- tiredness
- trouble breathing

If you get any of these symptoms during treatment with INVOKANA, if possible, check for ketones in your urine, even if your blood sugar is less than 250 mg/dL.

- **Vaginal yeast infection.** Symptoms of a vaginal yeast infection include:

- vaginal odor
- white or yellowish vaginal discharge (discharge may be lumpy or look like cottage cheese)
- vaginal itching

- **Yeast infection of the skin around the penis (balanitis or balanoposthitis).** Swelling of an uncircumcised penis may develop that makes it difficult to pull back the skin around the tip of the penis. Other symptoms of yeast infection of the penis include:

- redness, itching, or swelling of the penis
- foul smelling discharge from the penis
- rash of the penis
- pain in the skin around penis

Talk to your doctor about what to do if you get symptoms of a yeast infection of the vagina or penis. Your doctor may suggest you use an over-the-counter antifungal medicine. Talk to your doctor right away if you use an over-the-counter antifungal medication and your symptoms do not go away.

What is INVOKANA?

- INVOKANA is a prescription medicine used:
 - along with diet and exercise to lower blood sugar (glucose) in adults with type 2 diabetes.
 - to reduce the risk of major cardiovascular events such as heart attack, stroke or death in adults with type 2 diabetes who have known cardiovascular disease.
 - to reduce the risk of end stage kidney disease (ESKD), worsening of kidney function, cardiovascular death, and hospitalization for heart failure in adults with type 2 diabetes and diabetic kidney disease (nephropathy) with a certain amount of protein in the urine.
- INVOKANA is not for people with type 1 diabetes. It may increase their risk of diabetic ketoacidosis (increased ketones in blood or urine).
- INVOKANA is not used to lower blood sugar (glucose) in adults with type 2 diabetes with severe kidney problems.
- It is not known if INVOKANA is safe and effective in children under 18 years of age.

Do not take INVOKANA if you:

- are allergic to canagliflozin or any of the ingredients in INVOKANA. See the end of this Medication Guide for a list of ingredients in INVOKANA. Symptoms of allergic reaction to INVOKANA may include:
 - rash
 - raised red patches on your skin (hives)
 - swelling of the face, lips, mouth, tongue, and throat that may cause difficulty in breathing or swallowing
- are on kidney dialysis

Before taking INVOKANA, tell your doctor about all of your medical conditions, including if you:

- have a history of amputation.
- have heart disease or are at risk for heart disease.
- have had blocked or narrowed blood vessels, usually in your leg.
- have damage to the nerves (neuropathy) in your leg.
- have had diabetic foot ulcers or sores.
- have kidney problems.
- have liver problems.
- have a history of urinary tract infections or problems with urination.
- are on a low sodium (salt) diet. Your doctor may change your diet or your dose of INVOKANA.
- are going to have surgery. Your doctor may stop your INVOKANA before you have surgery. Talk to your doctor if you are having surgery about when to stop taking INVOKANA and when to start it again.
- are eating less or there is a change in your diet.
- have or have had problems with your pancreas, including pancreatitis or surgery on your pancreas.
- drink alcohol very often, or drink a lot of alcohol in the short-term (“binge” drinking).
- have ever had an allergic reaction to INVOKANA.
- are pregnant or plan to become pregnant. INVOKANA may harm your unborn baby. If you become pregnant while taking INVOKANA, tell your doctor as soon as possible. Talk with your doctor about the best way to control your blood sugar while you are pregnant.
- are breastfeeding or plan to breastfeed. INVOKANA may pass into your breast milk and may harm your baby. Talk with your doctor about the best way to feed your baby if you are taking INVOKANA. Do not breastfeed while taking INVOKANA.

Tell your doctor about all the medicines you take, including prescription and non-prescription medicines, vitamins, and herbal supplements.

INVOKANA may affect the way other medicines work, and other medicines may affect how INVOKANA works. Especially tell your doctor if you take:

- | | |
|---|--|
| • diuretics (water pills) | • rifampin (used to treat or prevent tuberculosis) |
| • phenytoin or phenobarbital (used to control seizures) | • ritonavir (used to treat HIV infection) |
| • digoxin (used to treat heart problems) | |

Ask your doctor or pharmacist for a list of these medicines if you are not sure if your medicine is listed above.

Know the medicines you take. Keep a list of them and show it to your doctor and pharmacist when you get a new medicine.

How should I take INVOKANA?

- Take INVOKANA by mouth 1 time each day exactly as your doctor tells you to take it.
- Your doctor will tell you how much INVOKANA to take and when to take it. Your doctor may change your dose if needed.
- It is best to take INVOKANA before the first meal of the day.

- Your doctor may tell you to take INVOKANA along with other diabetes medicines. Low blood sugar can happen more often when INVOKANA is taken with certain other diabetes medicines. See **“What are the possible side effects of INVOKANA?”**
- If you miss a dose, take it as soon as you remember. If it is almost time for your next dose, skip the missed dose and take the medicine at the next regularly scheduled time. Do not take two doses of INVOKANA at the same time. Talk to your doctor if you have questions about a missed dose.
- If you take too much INVOKANA, call your doctor or go to the nearest hospital emergency room right away.
- When your body is under some types of stress, such as fever, trauma (such as a car accident), infection, or surgery, the amount of diabetes medicine you need may change. Tell your doctor right away if you have any of these conditions and follow your doctor’s instructions.
- Stay on your prescribed diet and exercise program while taking INVOKANA.
- Check your blood sugar as your doctor tells you to.
- INVOKANA will cause your urine to test positive for glucose.
- Your doctor may do certain blood tests before you start INVOKANA and during treatment as needed. Your doctor may change your dose of INVOKANA based on the results of your blood tests.
- Your doctor will check your diabetes with regular blood tests, including your blood sugar levels and your hemoglobin A_{1c}.

What are the possible side effects of INVOKANA?

INVOKANA may cause serious side effects including:

See **“What is the most important information I should know about INVOKANA?”**

- **serious urinary tract infections.** Serious urinary tract infections that may lead to hospitalization have happened in people who are taking INVOKANA. Tell your doctor if you have any signs or symptoms of a urinary tract infection such as a burning feeling when passing urine, a need to urinate often, the need to urinate right away, pain in the lower part of your stomach (pelvis), or blood in the urine. Sometimes people may also have a fever, back pain, nausea, or vomiting.
- **low blood sugar (hypoglycemia).** If you take INVOKANA with another medicine that can cause low blood sugar, such as a sulfonylurea or insulin, your risk of getting low blood sugar is higher. The dose of your sulfonylurea medicine or insulin may need to be lowered while you take INVOKANA.
Signs and symptoms of low blood sugar may include:

○ headache	○ drowsiness	○ weakness
○ confusion	○ dizziness	○ irritability
○ hunger	○ fast heartbeat	○ sweating
○ shaking or feeling jittery		
- **a rare but serious bacterial infection that causes damage to the tissue under the skin (necrotizing fasciitis) in the area between and around the anus and genitals (perineum).** Necrotizing fasciitis of the perineum has happened in people who take INVOKANA. Necrotizing fasciitis of the perineum may lead to hospitalization, may require multiple surgeries, and may lead to death. **Seek medical attention immediately if you have fever or you are feeling very weak, tired or uncomfortable (malaise) and you develop any of the following symptoms in the area between and around your anus and genitals:**

○ pain or tenderness	○ swelling	○ redness of the skin (erythema)
----------------------	------------	----------------------------------
- **serious allergic reaction.** If you have any symptoms of a serious allergic reaction, stop taking INVOKANA and call your doctor right away or go to the nearest hospital emergency room. See **“Do not take INVOKANA if you:”**. Your doctor may give you a medicine for your allergic reaction and prescribe a different medicine for your diabetes.
- **broken bones (fractures).** Bone fractures have been seen in patients taking INVOKANA. Talk to your doctor about factors that may increase your risk of bone fracture.

The most common side effects of INVOKANA include:

- vaginal yeast infections and yeast infections of the penis (See **“What is the most important information I should know about INVOKANA?”**)
- changes in urination, including urgent need to urinate more often, in larger amounts, or at night

These are not all the possible side effects of INVOKANA.

Call your doctor for medical advice about side effects. You may report side effects to FDA at 1-800-FDA-1088.

You may also report side effects to Janssen Pharmaceuticals, Inc. at 1-800-526-7736.

How should I store INVOKANA?

- Store INVOKANA at room temperature between 68°F to 77°F (20°C to 25°C).
- **Keep INVOKANA and all medicines out of the reach of children.**

General information about the safe and effective use of INVOKANA.

Medicines are sometimes prescribed for purposes other than those listed in a Medication Guide. Do not use INVOKANA for a condition for which it was not prescribed. Do not give INVOKANA to other people, even if they have the same symptoms that you have. It may harm them.

You can ask your pharmacist or healthcare provider for information about INVOKANA that is written for health professionals.

What are the ingredients in INVOKANA?

Active ingredient: canagliflozin

Inactive ingredients: croscarmellose sodium, hydroxypropyl cellulose, lactose anhydrous, magnesium stearate, and microcrystalline cellulose. In addition, the tablet coating contains iron oxide yellow E172 (100 mg tablet only), macrogol/PEG, polyvinyl alcohol, talc, and titanium dioxide.

Active ingredient made in Belgium. Manufactured for: Janssen Pharmaceuticals, Inc., Titusville, NJ 08560. Licensed from Mitsubishi Tanabe Pharma Corporation. © 2013 - 2019 Janssen Pharmaceutical Companies

For more information about INVOKANA, call 1-800-526-7736 or visit our website at www.invokana.com.

This Medication Guide has been approved by the U.S. Food and Drug Administration.

Revised 08/2020

HIGHLIGHTS OF PRESCRIBING INFORMATION

These highlights do not include all the information needed to use JAKAFI safely and effectively. See full prescribing information for JAKAFI.

JAKAFI® (ruxolitinib) tablets, for oral use

Initial U.S. Approval: 2011

RECENT MAJOR CHANGES

Indications and Usage (1.3) 05/2019
Dosage and Administration (2.3) 05/2019

INDICATIONS AND USAGE

Jakafi is a kinase inhibitor indicated for treatment of

- intermediate or high-risk myelofibrosis, including primary myelofibrosis, post-polycythemia vera myelofibrosis and post-essential thrombocythemia myelofibrosis in adults. (1.1)
- polycythemia vera in adults who have had an inadequate response to or are intolerant of hydroxyurea. (1.2)
- steroid-refractory acute graft-versus-host disease in adult and pediatric patients 12 years and older. (1.3)

DOSAGE AND ADMINISTRATION

Doses should be individualized based on safety and efficacy. Starting doses per indication are noted below.

Myelofibrosis (2.1)

- The starting dose of Jakafi is based on patient's baseline platelet count:
 - Greater than $200 \times 10^9/L$: 20 mg given orally twice daily
 - $100 \times 10^9/L$ to $200 \times 10^9/L$: 15 mg given orally twice daily
 - $50 \times 10^9/L$ to less than $100 \times 10^9/L$: 5 mg given orally twice daily
- Monitor complete blood counts every 2 to 4 weeks until doses are stabilized, and then as clinically indicated. Modify or interrupt dosing for thrombocytopenia.

Polycythemia Vera (2.2)

- The starting dose of Jakafi is 10 mg given orally twice daily.

Acute Graft-Versus-Host Disease (2.3)

- The starting dose of Jakafi is 5 mg given orally twice daily.

DOSAGE FORMS AND STRENGTHS

Tablets: 5 mg, 10 mg, 15 mg, 20 mg and 25 mg. (3)

CONTRAINDICATIONS

None. (4)

WARNINGS AND PRECAUTIONS

- Thrombocytopenia, Anemia and Neutropenia: Manage by dose reduction, or interruption, or transfusion. (5.1)
- Risk of Infection: Assess patients for signs and symptoms of infection and initiate appropriate treatment promptly. Serious infections should have resolved before starting therapy with Jakafi. (5.2)
- Symptom Exacerbation Following Interruption or Discontinuation: Manage with supportive care and consider resuming treatment with Jakafi. (5.3)
- Risk of Non-Melanoma Skin Cancer: Perform periodic skin examinations. (5.4)
- Lipid Elevations: Assess lipid levels 8-12 weeks from start of therapy and treat as needed. (5.5)

ADVERSE REACTIONS

- In myelofibrosis and polycythemia vera, the most common hematologic adverse reactions (incidence > 20%) are thrombocytopenia and anemia. The most common nonhematologic adverse reactions (incidence \geq 15%) are bruising, dizziness, headache, and diarrhea. (6.1 and 6.2)
- In acute graft-versus-host disease, the most common hematologic adverse reactions (incidence > 50%) are anemia, thrombocytopenia, and neutropenia. The most common nonhematologic adverse reactions (incidence > 50%) are infections and edema. (6.3)

To report SUSPECTED ADVERSE REACTIONS, contact Incyte Corporation at 1-855-463-3463 or FDA at 1-800-FDA-1088 or www.fda.gov/medwatch.

DRUG INTERACTIONS

- Strong CYP3A4 Inhibitors or Fluconazole: Reduce, interrupt, or discontinue Jakafi doses as recommended. Avoid use of Jakafi with fluconazole doses greater than 200 mg except in patients with acute graft-versus-host disease. (2.4, 7)

USE IN SPECIFIC POPULATIONS

- Renal Impairment: Reduce Jakafi starting dose or avoid treatment as recommended. (2.5, 8.6)
- Hepatic Impairment: Reduce Jakafi starting dose or avoid treatment as recommended. (2.5, 8.7)
- Lactation: Advise not to breastfeed. (8.2)

See 17 for PATIENT COUNSELING INFORMATION and FDA-approved patient labeling.

Revised: 01/2020

FULL PRESCRIBING INFORMATION: CONTENTS*

1 INDICATIONS AND USAGE

- 1.1 Myelofibrosis
- 1.2 Polycythemia Vera
- 1.3 Acute Graft-Versus-Host Disease

2 DOSAGE AND ADMINISTRATION

- 2.1 Myelofibrosis
- 2.2 Polycythemia Vera
- 2.3 Acute Graft-Versus-Host Disease
- 2.4 Dose Modifications for Concomitant Use with Strong CYP3A4 Inhibitors or Fluconazole
- 2.5 Dose Modifications for Organ Impairment
- 2.6 Method of Administration

3 DOSAGE FORMS AND STRENGTHS

4 CONTRAINDICATIONS

5 WARNINGS AND PRECAUTIONS

- 5.1 Thrombocytopenia, Anemia and Neutropenia
- 5.2 Risk of Infection
- 5.3 Symptom Exacerbation Following Interruption or Discontinuation of Treatment with Jakafi
- 5.4 Non-Melanoma Skin Cancer
- 5.5 Lipid Elevations

6 ADVERSE REACTIONS

- 6.1 Clinical Trials Experience in Myelofibrosis
- 6.2 Clinical Trial Experience in Polycythemia Vera
- 6.3 Clinical Trial Experience in Acute Graft-Versus-Host Disease

7 DRUG INTERACTIONS

8 USE IN SPECIFIC POPULATIONS

- 8.1 Pregnancy
- 8.2 Lactation
- 8.4 Pediatric Use
- 8.5 Geriatric Use
- 8.6 Renal Impairment
- 8.7 Hepatic Impairment

10 OVERDOSAGE

11 DESCRIPTION

12 CLINICAL PHARMACOLOGY

- 12.1 Mechanism of Action
- 12.2 Pharmacodynamics
- 12.3 Pharmacokinetics

13 NONCLINICAL TOXICOLOGY

- 13.1 Carcinogenesis, Mutagenesis, Impairment of Fertility

14 CLINICAL STUDIES

- 14.1 Myelofibrosis
- 14.2 Polycythemia Vera
- 14.3 Acute Graft-Versus-Host Disease

16 HOW SUPPLIED/STORAGE AND HANDLING

17 PATIENT COUNSELING INFORMATION

*Sections or subsections omitted from the full prescribing information are not listed.

FULL PRESCRIBING INFORMATION

1 INDICATIONS AND USAGE

1.1 Myelofibrosis

Jakafi is indicated for treatment of intermediate or high-risk myelofibrosis (MF), including primary MF, post-polycythemia vera MF and post-essential thrombocythemia MF in adults.

1.2 Polycythemia Vera

Jakafi is indicated for treatment of polycythemia vera (PV) in adults who have had an inadequate response to or are intolerant of hydroxyurea.

1.3 Acute Graft-Versus-Host Disease

Jakafi is indicated for treatment of steroid-refractory acute graft-versus-host disease (GVHD) in adult and pediatric patients 12 years and older.

2 DOSAGE AND ADMINISTRATION

2.1 Myelofibrosis

The recommended starting dose of Jakafi is based on platelet count ([Table 1](#)). A complete blood count (CBC) and platelet count must be performed before initiating therapy, every 2 to 4 weeks until doses are stabilized, and then as clinically indicated [*see Warnings and Precautions (5.1)*]. Doses may be titrated based on safety and efficacy.

Table 1: Jakafi Starting Doses for Myelofibrosis

Platelet Count	Starting Dose
Greater than $200 \times 10^9/L$	20 mg orally twice daily
$100 \times 10^9/L$ to $200 \times 10^9/L$	15 mg orally twice daily
$50 \times 10^9/L$ to less than $100 \times 10^9/L$	5 mg orally twice daily

Dose Modification Guidelines for Hematologic Toxicity for Patients with Myelofibrosis Starting Treatment with a Platelet Count of $100 \times 10^9/L$ or Greater

Treatment Interruption and Restarting Dosing

Interrupt treatment for platelet counts less than $50 \times 10^9/L$ or absolute neutrophil count (ANC) less than $0.5 \times 10^9/L$.

After recovery of platelet counts above $50 \times 10^9/L$ and ANC above $0.75 \times 10^9/L$, dosing may be restarted. [Table 2](#) illustrates the maximum allowable dose that may be used in restarting Jakafi after a previous interruption.

Table 2: Myelofibrosis: Maximum Restarting Doses for Jakafi after Safety Interruption for Thrombocytopenia for Patients Starting Treatment with a Platelet Count of $100 \times 10^9/L$ or Greater

Current Platelet Count	Maximum Dose When Restarting Jakafi Treatment*
Greater than or equal to $125 \times 10^9/L$	20 mg twice daily
100 to less than $125 \times 10^9/L$	15 mg twice daily
75 to less than $100 \times 10^9/L$	10 mg twice daily for at least 2 weeks; if stable, may increase to 15 mg twice daily
50 to less than $75 \times 10^9/L$	5 mg twice daily for at least 2 weeks; if stable, may increase to 10 mg twice daily
Less than $50 \times 10^9/L$	Continue hold

*Maximum doses are displayed. When restarting, begin with a dose at least 5 mg twice daily below the dose at interruption.

Following treatment interruption for ANC below $0.5 \times 10^9/L$, after ANC recovers to $0.75 \times 10^9/L$ or greater, restart dosing at the higher of 5 mg once daily or 5 mg twice daily below the largest dose in the week prior to the treatment interruption.

Dose Reductions

Dose reductions should be considered if the platelet counts decrease as outlined in [Table 3](#) with the goal of avoiding dose interruptions for thrombocytopenia.

Table 3: Myelofibrosis: Dosing Recommendations for Thrombocytopenia for Patients Starting Treatment with a Platelet Count of $100 \times 10^9/L$ or Greater

Platelet Count	Dose at Time of Platelet Decline				
	25 mg twice daily	20 mg twice daily	15 mg twice daily	10 mg twice daily	5 mg twice daily
	New Dose	New Dose	New Dose	New Dose	New Dose
100 to less than $125 \times 10^9/L$	20 mg twice daily	15 mg twice daily	No Change	No Change	No Change
75 to less than $100 \times 10^9/L$	10 mg twice daily	10 mg twice daily	10 mg twice daily	No Change	No Change
50 to less than $75 \times 10^9/L$	5 mg twice daily	5 mg twice daily	5 mg twice daily	5 mg twice daily	No Change
Less than $50 \times 10^9/L$	Hold	Hold	Hold	Hold	Hold

Dose Modification Based on Insufficient Response for Patients with Myelofibrosis Starting Treatment with a Platelet Count of $100 \times 10^9/L$ or Greater

If the response is insufficient and platelet and neutrophil counts are adequate, doses may be increased in 5 mg twice daily increments to a maximum of 25 mg twice daily. Doses should not be increased during the first 4 weeks of therapy and not more frequently than every 2 weeks.

Consider dose increases in patients who meet all of the following conditions:

- a. Failure to achieve a reduction from pretreatment baseline in either palpable spleen length of 50% or a 35% reduction in spleen volume as measured by computed tomography (CT) or magnetic resonance imaging (MRI);
- b. Platelet count greater than $125 \times 10^9/L$ at 4 weeks and platelet count never below $100 \times 10^9/L$;
- c. ANC Levels greater than $0.75 \times 10^9/L$.

Based on limited clinical data, long-term maintenance at a 5 mg twice daily dose has not shown responses and continued use at this dose should be limited to patients in whom the benefits outweigh the potential risks. Discontinue Jakafi if there is no spleen size reduction or symptom improvement after 6 months of therapy.

Dose Modifications for Hematologic Toxicity for Patients with Myelofibrosis Starting Treatment with Platelet Counts of $50 \times 10^9/L$ to Less Than $100 \times 10^9/L$

This section applies only to patients with platelet counts of $50 \times 10^9/L$ to less than $100 \times 10^9/L$ prior to any treatment with Jakafi. See dose modifications in Section 2.1 (*Dose Modification Guidelines for Hematological Toxicity for Patients with Myelofibrosis Starting Treatment with a Platelet Count of $100 \times 10^9/L$ or Greater*) for hematological toxicity in patients whose platelet counts were $100 \times 10^9/L$ or more prior to starting treatment with Jakafi.

Treatment Interruption and Restarting Dosing

Interrupt treatment for platelet counts less than $25 \times 10^9/L$ or ANC less than $0.5 \times 10^9/L$.

After recovery of platelet counts above $35 \times 10^9/L$ and ANC above $0.75 \times 10^9/L$, dosing may be restarted. Restart dosing at the higher of 5 mg once daily or 5 mg twice daily below the largest dose in the week prior to the decrease in platelet count below $25 \times 10^9/L$ or ANC below $0.5 \times 10^9/L$ that led to dose interruption.

Dose Reductions

Reduce the dose of Jakafi for platelet counts less than $35 \times 10^9/L$ as described in [Table 4](#).

Table 4: Myelofibrosis: Dosing Modifications for Thrombocytopenia for Patients with Starting Platelet Count of 50 X 10⁹/L to Less Than 100 X 10⁹/L

Platelet Count	Dosing Recommendations
Less than 25 X 10 ⁹ /L	<ul style="list-style-type: none"> • Interrupt dosing.
25 X 10 ⁹ /L to less than 35 X 10 ⁹ /L AND the platelet count decline is less than 20% during the prior four weeks	<ul style="list-style-type: none"> • Decrease dose by 5 mg once daily. • For patients on 5 mg once daily, maintain dose at 5 mg once daily.
25 X 10 ⁹ /L to less than 35 X 10 ⁹ /L AND the platelet count decline is 20% or greater during the prior four weeks	<ul style="list-style-type: none"> • Decrease dose by 5 mg twice daily. • For patients on 5 mg twice daily, decrease the dose to 5 mg once daily. • For patients on 5 mg once daily, maintain dose at 5 mg once daily.

Dose Modifications Based on Insufficient Response for Patients with Myelofibrosis and Starting Platelet Count of 50 X 10⁹/L to Less Than 100 X 10⁹/L

Do not increase doses during the first 4 weeks of therapy, and do not increase the dose more frequently than every 2 weeks.

If the response is insufficient as defined in Section 2.1 (*see Dose Modification Based on Insufficient Response with Myelofibrosis Starting Treatment with a platelet count of 100 X 10⁹/L or Greater*), doses may be increased by increments of 5 mg daily to a maximum of 10 mg twice daily if:

- a) the platelet count has remained at least 40 X 10⁹/L, and
- b) the platelet count has not fallen by more than 20% in the prior 4 weeks, and
- c) the ANC is more than 1 X 10⁹/L, and
- d) the dose has not been reduced or interrupted for an adverse event or hematological toxicity in the prior 4 weeks.

Continuation of treatment for more than 6 months should be limited to patients in whom the benefits outweigh the potential risks. Discontinue Jakafi if there is no spleen size reduction or symptom improvement after 6 months of therapy.

Dose Modification for Bleeding

Interrupt treatment for bleeding requiring intervention regardless of current platelet count. Once the bleeding event has resolved, consider resuming treatment at the prior dose if the underlying cause of bleeding has been controlled. If the bleeding event has resolved but the underlying cause persists, consider resuming treatment with Jakafi at a lower dose.

2.2 Polycythemia Vera

The recommended starting dose of Jakafi is 10 mg twice daily. Doses may be titrated based on safety and efficacy.

Dose Modification Guidelines for Patients with Polycythemia Vera

A complete blood count (CBC) and platelet count must be performed before initiating therapy, every 2 to 4 weeks until doses are stabilized, and then as clinically indicated [*see Warnings and Precautions (5.1)*].

Dose Reductions

Dose reductions should be considered for hemoglobin and platelet count decreases as described in [Table 5](#).

Table 5: Polycythemia Vera: Dose Reductions

Hemoglobin and/or Platelet Count	Dosing Recommendations
Hemoglobin greater than or equal to 12 g/dL AND platelet count greater than or equal to $100 \times 10^9/L$	<ul style="list-style-type: none">No change required.
Hemoglobin 10 to less than 12 g/dL AND platelet count 75 to less than $100 \times 10^9/L$	<ul style="list-style-type: none">Dose reductions should be considered with the goal of avoiding dose interruptions for anemia and thrombocytopenia.
Hemoglobin 8 to less than 10 g/dL OR platelet count 50 to less than $75 \times 10^9/L$	<ul style="list-style-type: none">Reduce dose by 5 mg twice daily.For patients on 5 mg twice daily, decrease the dose to 5 mg once daily.
Hemoglobin less than 8 g/dL OR platelet count less than $50 \times 10^9/L$	<ul style="list-style-type: none">Interrupt dosing.

Treatment Interruption and Restarting Dosing

Interrupt treatment for hemoglobin less than 8 g/dL, platelet counts less than $50 \times 10^9/L$ or ANC less than $1.0 \times 10^9/L$.

After recovery of the hematologic parameter(s) to acceptable levels, dosing may be restarted.

[Table 6](#) illustrates the dose that may be used in restarting Jakafi after a previous interruption.

Table 6: Polycythemia Vera: Restarting Doses for Jakafi after Safety Interruption for Hematologic Parameter(s)

Use the **most severe category** of a patient's hemoglobin, platelet count, or ANC abnormality to determine the corresponding maximum restarting dose.

Hemoglobin, Platelet Count, or ANC	Maximum Restarting Dose
Hemoglobin less than 8 g/dL OR platelet count less than 50 X 10 ⁹ /L OR ANC less than 1 X 10 ⁹ /L	Continue hold
Hemoglobin 8 to less than 10 g/dL OR platelet count 50 to less than 75 X 10 ⁹ /L OR ANC 1 to less than 1.5 X 10 ⁹ /L	5 mg twice daily ^a or no more than 5 mg twice daily less than the dose which resulted in dose interruption
Hemoglobin 10 to less than 12 g/dL OR platelet count 75 to less than 100 X 10 ⁹ /L OR ANC 1.5 to less than 2 X 10 ⁹ /L	10 mg twice daily ^a or no more than 5 mg twice daily less than the dose which resulted in dose interruption
Hemoglobin greater than or equal to 12 g/dL OR platelet count greater than or equal to 100 X 10 ⁹ /L OR ANC greater than or equal to 2 X 10 ⁹ /L	15 mg twice daily ^a or no more than 5 mg twice daily less than the dose which resulted in dose interruption

^a Continue treatment for at least 2 weeks; if stable, may increase dose by 5 mg twice daily.

Patients who had required dose interruption while receiving a dose of 5 mg twice daily, may restart at a dose of 5 mg twice daily or 5 mg once daily, but not higher, once hemoglobin is greater than or equal to 10 g/dL, platelet count is greater than or equal to 75 X 10⁹/L, and ANC is greater than or equal to 1.5 X 10⁹/L.

Dose Management after Restarting Treatment

After restarting Jakafi following treatment interruption, doses may be titrated, but the maximum total daily dose should not exceed 5 mg less than the dose that resulted in the dose interruption. An exception to this is dose interruption following phlebotomy-associated anemia, in which case the maximal total daily dose allowed after restarting Jakafi would not be limited.

Dose Modifications Based on Insufficient Response for Patients with Polycythemia Vera

If the response is insufficient and platelet, hemoglobin, and neutrophil counts are adequate, doses may be increased in 5 mg twice daily increments to a maximum of 25 mg twice daily. Doses should not be increased during the first 4 weeks of therapy and not more frequently than every two weeks.

Consider dose increases in patients who meet all of the following conditions:

1. Inadequate efficacy as demonstrated by one or more of the following:
 - a. Continued need for phlebotomy
 - b. WBC greater than the upper limit of normal range

- c. Platelet count greater than the upper limit of normal range
 - d. Palpable spleen that is reduced by less than 25% from Baseline
2. Platelet count greater than or equal to $140 \times 10^9/L$
 3. Hemoglobin greater than or equal to 12 g/dL
 4. ANC greater than or equal to $1.5 \times 10^9/L$

2.3 Acute Graft-Versus-Host Disease

The recommended starting dose of Jakafi is 5 mg given orally twice daily. Consider increasing the dose to 10 mg twice daily after at least 3 days of treatment if the ANC and platelet counts are not decreased by 50% or more relative to the first day of dosing with Jakafi.

Tapering of Jakafi may be considered after 6 months of treatment in patients with response who have discontinued therapeutic doses of corticosteroids. Taper Jakafi by one dose level approximately every 8 weeks (10 mg twice daily to 5 mg twice daily to 5 mg once daily). If acute GVHD signs or symptoms recur during or after the taper of Jakafi, consider retreatment.

Dose Modification Guidelines for Patients with Acute Graft-Versus-Host Disease

Evaluate blood parameters before and during treatment with Jakafi. Dose reductions should be considered for platelet counts, ANCs or bilirubin value as described in Table 7. Patients who are currently receiving Jakafi 10 mg twice daily may have their dose reduced to 5 mg twice daily; patients receiving 5 mg twice daily may have their dose reduced to 5 mg once daily. Patients who are unable to tolerate Jakafi at a dose of 5 mg once daily should have treatment interrupted until their clinical and/or laboratory parameters recover.

Table 7: Dose Modifications for Patients with Acute GVHD

Laboratory Parameter	Dosing Recommendations
Clinically significant thrombocytopenia after supportive measures	Reduce dose by 1 dose level. When platelets recover to previous values, dosing may return to prior dose level.
ANC less than $1 \times 10^9/L$ considered related to Jakafi	Hold Jakafi for up to 14 days; resume at 1 dose level lower upon recovery.
Total Bilirubin elevation, no liver GVHD	3.0–5.0 × ULN: Continue Jakafi at 1 dose level lower until recovery. >5.0–10.0 × ULN: Hold Jakafi for up to 14 days until bilirubin ≤ 1.5 × ULN; resume at current dose upon recovery Total bilirubin > 10.0 × ULN: Hold Jakafi for up to 14 days until bilirubin ≤ 1.5 × ULN; resume at 1 dose level lower upon recovery.
Total Bilirubin elevation, liver GVHD	>3.0 × ULN: Continue Jakafi at 1 dose level lower until recovery.

2.4 Dose Modifications for Concomitant Use with Strong CYP3A4 Inhibitors or Fluconazole

Modify the Jakafi dosage when coadministered with strong CYP3A4 inhibitors and fluconazole doses of less than or equal to 200 mg [*see Drug Interactions (7)*], according to [Table 8](#).

Additional dose modifications should be made with frequent monitoring of safety and efficacy.

Avoid the use of fluconazole doses of greater than 200 mg daily with Jakafi except in patients with acute GVHD.

Table 8: Dose Modifications for Concomitant Use with Strong CYP3A4 Inhibitors or Fluconazole

For patients coadministered strong CYP3A4 inhibitors or fluconazole doses of less than or equal to 200 mg	Recommended Dose Modification
Starting dose for patients with MF with a platelet count:	
<ul style="list-style-type: none"> Greater than or equal to $100 \times 10^9/L$ 	10 mg twice daily
<ul style="list-style-type: none"> $50 \times 10^9/L$ to less than $100 \times 10^9/L$ 	5 mg once daily
Starting dose for patients with PV:	5 mg twice daily
If on stable dose for patients with MF or PV:	
<ul style="list-style-type: none"> Greater than or equal to 10 mg twice daily 	Decrease dose by 50% (round up to the closest available tablet strength)
<ul style="list-style-type: none"> 5 mg twice daily 	5 mg once daily
<ul style="list-style-type: none"> 5 mg once daily 	Avoid strong CYP3A4 inhibitor or fluconazole treatment or interrupt Jakafi treatment for the duration of strong CYP3A4 inhibitor or fluconazole use
For patients with acute GVHD:	
Ketoconazole	5 mg once daily
Other CYP3A4 inhibitors*	No dose adjustment

*With coadministration of itraconazole, monitor blood counts more frequently for toxicity and adjust the dose of Jakafi if necessary.

2.5 Dose Modifications for Renal or Hepatic Impairment

Renal Impairment

Patients with Moderate or Severe Renal Impairment

Modify the Jakafi dosage for patients with moderate or severe renal impairment according to [Table 9](#).

Patients with End Stage Renal Disease on Dialysis

Modify the Jakafi dosage for patients with end stage renal disease (ESRD) on dialysis according to [Table 9](#). Make additional dose modifications with frequent monitoring of safety and efficacy. Avoid use of Jakafi in patients with ESRD (CLcr less than 15 mL/min) not requiring dialysis [see *Use in Specific Populations (8.6)*].

Table 9: Dose Modifications for Renal Impairment

Renal Impairment Status	Platelet Count	Recommended Starting Dosage
Patients with MF		
Moderate (CLcr 30 to 59 mL/min) or Severe (CLcr 15 to 29 mL/min)	Greater than 150 X 10 ⁹ /L	No dose modification needed
	100 to 150 X 10 ⁹ /L	10 mg twice daily
	50 to less than 100 X 10 ⁹ /L	5 mg daily
	Less than 50 X 10 ⁹ /L	Avoid use [see <i>Use in Specific Populations (8.6)</i>]
ESRD (CLcr less than 15 mL/min) on dialysis	100 to 200 X 10 ⁹ /L	15 mg once after dialysis session
	Greater than 200 X 10 ⁹ /L	20 mg once after dialysis session
Patients with PV		
Moderate (CLcr 30 to 59 mL/min) or Severe (CLcr 15 to 29 mL/min)	Any	5 mg twice daily
ESRD (CLcr less than 15 mL/min) on dialysis	Any	10 mg once after dialysis session
Patients with acute GVHD		
Moderate (CLcr 30 to 59 mL/min) or Severe (CLcr 15 to 29 mL/min)	Any	5 mg once daily
ESRD (CLcr less than 15 mL/min) on dialysis	Any	5 mg once after dialysis session

ESRD = end stage renal disease, and CLcr = creatinine clearance

Hepatic Impairment

Modify the Jakafi dosage for patients with hepatic impairment according to [Table 10](#).

Table 10: Dose Modifications for Hepatic Impairment

Hepatic Impairment Status	Platelet Count	Recommended Starting Dosage
Patients with MF Mild, Moderate, or Severe (Child-Pugh Class A, B, C)	Greater than $150 \times 10^9/L$	No dose modification needed
	$100 \times 10^9/L$ to $150 \times 10^9/L$	10 mg twice daily
	50 to less than $100 \times 10^9/L$	5 mg daily
	Less than $50 \times 10^9/L$	Avoid use [<i>see Use in Specific Populations (8.7)</i>]
Patients with PV Mild, Moderate, or Severe (Child-Pugh Class A, B, C)	Any	5 mg twice daily
Patients with acute GVHD Mild, Moderate, or Severe based on NCI criteria Stage 3 or 4 liver GVHD	Any	No dose modification needed
	Any	Monitor blood counts more frequently for toxicity and consider 5 mg once daily

2.6 Method of Administration

Jakafi is dosed orally and can be administered with or without food.

If a dose is missed, the patient should not take an additional dose, but should take the next usual prescribed dose.

When discontinuing Jakafi therapy for reasons other than thrombocytopenia, gradual tapering of the dose of Jakafi may be considered, for example by 5 mg twice daily each week.

For patients unable to ingest tablets, Jakafi can be administered through a nasogastric tube (8 French or greater) as follows:

- Suspend one tablet in approximately 40 mL of water with stirring for approximately 10 minutes.
- Within 6 hours after the tablet has dispersed, the suspension can be administered through a nasogastric tube using an appropriate syringe.

The tube should be rinsed with approximately 75 mL of water. The effect of tube feeding preparations on Jakafi exposure during administration through a nasogastric tube has not been evaluated.

3 DOSAGE FORMS AND STRENGTHS

5 mg tablets - round and white with “INCY” on one side and “5” on the other.

10 mg tablets - round and white with “INCY” on one side and “10” on the other.

15 mg tablets - oval and white with “INCY” on one side and “15” on the other.

20 mg tablets - capsule-shaped and white with “INCY” on one side and “20” on the other.

25 mg tablets - oval and white with “INCY” on one side and “25” on the other.

4 CONTRAINDICATIONS

None.

5 WARNINGS AND PRECAUTIONS

5.1 Thrombocytopenia, Anemia and Neutropenia

Treatment with Jakafi can cause thrombocytopenia, anemia and neutropenia [*see Dosage and Administration (2.1)*].

Manage thrombocytopenia by reducing the dose or temporarily interrupting Jakafi. Platelet transfusions may be necessary [*see Dosage and Administration (2), and Adverse Reactions (6.1)*].

Patients developing anemia may require blood transfusions and/or dose modifications of Jakafi.

Severe neutropenia (ANC less than $0.5 \times 10^9/L$) was generally reversible by withholding Jakafi until recovery [*see Adverse Reactions (6.1)*].

Perform a pre-treatment complete blood count (CBC) and monitor CBCs every 2 to 4 weeks until doses are stabilized, and then as clinically indicated [*see Dosage and Administration (2), and Adverse Reactions (6.1)*].

5.2 Risk of Infection

Serious bacterial, mycobacterial, fungal and viral infections have occurred. Delay starting therapy with Jakafi until active serious infections have resolved. Observe patients receiving Jakafi for signs and symptoms of infection and manage promptly. Use active surveillance and prophylactic antibiotics according to clinical guidelines.

Tuberculosis

Tuberculosis infection has been reported in patients receiving Jakafi. Observe patients receiving Jakafi for signs and symptoms of active tuberculosis and manage promptly.

Prior to initiating Jakafi, patients should be evaluated for tuberculosis risk factors, and those at higher risk should be tested for latent infection. Risk factors include, but are not limited to, prior residence in or travel to countries with a high prevalence of tuberculosis, close contact with a

person with active tuberculosis, and a history of active or latent tuberculosis where an adequate course of treatment cannot be confirmed.

For patients with evidence of active or latent tuberculosis, consult a physician with expertise in the treatment of tuberculosis before starting Jakafi. The decision to continue Jakafi during treatment of active tuberculosis should be based on the overall risk-benefit determination.

Progressive Multifocal Leukoencephalopathy

Progressive multifocal leukoencephalopathy (PML) has occurred with Jakafi treatment. If PML is suspected, stop Jakafi and evaluate.

Herpes Zoster

Advise patients about early signs and symptoms of herpes zoster and to seek treatment as early as possible if suspected [*see Adverse Reactions (6.1)*].

Hepatitis B

Hepatitis B viral load (HBV-DNA titer) increases, with or without associated elevations in alanine aminotransferase and aspartate aminotransferase, have been reported in patients with chronic HBV infections taking Jakafi. The effect of Jakafi on viral replication in patients with chronic HBV infection is unknown. Patients with chronic HBV infection should be treated and monitored according to clinical guidelines.

5.3 Symptom Exacerbation Following Interruption or Discontinuation of Treatment with Jakafi

Following discontinuation of Jakafi, symptoms from myeloproliferative neoplasms may return to pretreatment levels over a period of approximately one week. Some patients with MF have experienced one or more of the following adverse events after discontinuing Jakafi: fever, respiratory distress, hypotension, DIC, or multi-organ failure. If one or more of these occur after discontinuation of, or while tapering the dose of Jakafi, evaluate for and treat any intercurrent illness and consider restarting or increasing the dose of Jakafi. Instruct patients not to interrupt or discontinue Jakafi therapy without consulting their physician. When discontinuing or interrupting therapy with Jakafi for reasons other than thrombocytopenia or neutropenia [*see Dosage and Administration (2.6)*], consider tapering the dose of Jakafi gradually rather than discontinuing abruptly.

5.4 Non-Melanoma Skin Cancer

Non-melanoma skin cancers including basal cell, squamous cell, and Merkel cell carcinoma have occurred in patients treated with Jakafi. Perform periodic skin examinations.

5.5 Lipid Elevations

Treatment with Jakafi has been associated with increases in lipid parameters including total cholesterol, low-density lipoprotein (LDL) cholesterol, and triglycerides. The effect of these lipid parameter elevations on cardiovascular morbidity and mortality has not been determined in patients treated with Jakafi. Assess lipid parameters approximately 8-12 weeks following

initiation of Jakafi therapy. Monitor and treat according to clinical guidelines for the management of hyperlipidemia.

6 ADVERSE REACTIONS

The following clinically significant adverse reactions are discussed in greater detail in other sections of the labeling:

- Thrombocytopenia, Anemia and Neutropenia [*see Warnings and Precautions (5.1)*]
- Risk of Infection [*see Warnings and Precautions (5.2)*]
- Symptom Exacerbation Following Interruption or Discontinuation of Treatment with Jakafi [*see Warnings and Precautions (5.3)*]
- Non-Melanoma Skin Cancer [*see Warnings and Precautions (5.4)*]

6.1 Clinical Trials Experience in Myelofibrosis

Because clinical trials are conducted under widely varying conditions, adverse reaction rates observed in the clinical trials of a drug cannot be directly compared to rates in the clinical trials of another drug and may not reflect the rates observed in practice.

The safety of Jakafi was assessed in 617 patients in six clinical studies with a median duration of follow-up of 10.9 months, including 301 patients with MF in two Phase 3 studies.

In these two Phase 3 studies, patients had a median duration of exposure to Jakafi of 9.5 months (range 0.5 to 17 months), with 89% of patients treated for more than 6 months and 25% treated for more than 12 months. One hundred and eleven (111) patients started treatment at 15 mg twice daily and 190 patients started at 20 mg twice daily. In patients starting treatment with 15 mg twice daily (pretreatment platelet counts of 100 to 200 X 10⁹/L) and 20 mg twice daily (pretreatment platelet counts greater than 200 X 10⁹/L), 65% and 25% of patients, respectively, required a dose reduction below the starting dose within the first 8 weeks of therapy.

In a double-blind, randomized, placebo-controlled study of Jakafi, among the 155 patients treated with Jakafi, the most frequent adverse reactions were thrombocytopenia and anemia [*see Table 12*]. Thrombocytopenia, anemia and neutropenia are dose-related effects. The three most frequent nonhematologic adverse reactions were bruising, dizziness and headache [*see Table 11*].

Discontinuation for adverse events, regardless of causality, was observed in 11% of patients treated with Jakafi and 11% of patients treated with placebo.

[Table 11](#) presents the most common nonhematologic adverse reactions occurring in patients who received Jakafi in the double-blind, placebo-controlled study during randomized treatment.

Table 11: Myelofibrosis: Nonhematologic Adverse Reactions Occurring in Patients on Jakafi in the Double-blind, Placebo-controlled Study During Randomized Treatment

Adverse Reactions	Jakafi (N=155)			Placebo (N=151)		
	All Grades ^a (%)	Grade 3 (%)	Grade 4 (%)	All Grades (%)	Grade 3 (%)	Grade 4 (%)
Bruising ^b	23	<1	0	15	0	0
Dizziness ^c	18	<1	0	7	0	0
Headache	15	0	0	5	0	0
Urinary Tract Infections ^d	9	0	0	5	<1	<1
Weight Gain ^e	7	<1	0	1	<1	0
Flatulence	5	0	0	<1	0	0
Herpes Zoster ^f	2	0	0	<1	0	0

^a National Cancer Institute Common Terminology Criteria for Adverse Events (CTCAE), version 3.0

^b includes contusion, ecchymosis, hematoma, injection site hematoma, periorbital hematoma, vessel puncture site hematoma, increased tendency to bruise, petechiae, purpura

^c includes dizziness, postural dizziness, vertigo, balance disorder, Meniere's Disease, labyrinthitis

^d includes urinary tract infection, cystitis, urosepsis, urinary tract infection bacterial, kidney infection, pyuria, bacteria urine, bacteria urine identified, nitrite urine present

^e includes weight increased, abnormal weight gain

^f includes herpes zoster and post-herpetic neuralgia

Description of Selected Adverse Reactions

Anemia

In the two Phase 3 clinical studies, median time to onset of first CTCAE Grade 2 or higher anemia was approximately 6 weeks. One patient (<1%) discontinued treatment because of anemia. In patients receiving Jakafi, mean decreases in hemoglobin reached a nadir of approximately 1.5 to 2.0 g/dL below baseline after 8 to 12 weeks of therapy and then gradually recovered to reach a new steady state that was approximately 1.0 g/dL below baseline. This pattern was observed in patients regardless of whether they had received transfusions during therapy.

In the randomized, placebo-controlled study, 60% of patients treated with Jakafi and 38% of patients receiving placebo received red blood cell transfusions during randomized treatment. Among transfused patients, the median number of units transfused per month was 1.2 in patients treated with Jakafi and 1.7 in placebo treated patients.

Thrombocytopenia

In the two Phase 3 clinical studies, in patients who developed Grade 3 or 4 thrombocytopenia, the median time to onset was approximately 8 weeks. Thrombocytopenia was generally reversible with dose reduction or dose interruption. The median time to recovery of platelet counts above $50 \times 10^9/L$ was 14 days. Platelet transfusions were administered to 5% of patients

receiving Jakafi and to 4% of patients receiving control regimens. Discontinuation of treatment because of thrombocytopenia occurred in <1% of patients receiving Jakafi and <1% of patients receiving control regimens. Patients with a platelet count of 100 X 10⁹/L to 200 X 10⁹/L before starting Jakafi had a higher frequency of Grade 3 or 4 thrombocytopenia compared to patients with a platelet count greater than 200 X 10⁹/L (17% versus 7%).

Neutropenia

In the two Phase 3 clinical studies, 1% of patients reduced or stopped Jakafi because of neutropenia.

Table 12 provides the frequency and severity of clinical hematology abnormalities reported for patients receiving treatment with Jakafi or placebo in the placebo-controlled study.

Table 12: Myelofibrosis: Worst Hematology Laboratory Abnormalities in the Placebo-Controlled Study^a

Laboratory Parameter	Jakafi (N=155)			Placebo (N=151)		
	All Grades ^b (%)	Grade 3 (%)	Grade 4 (%)	All Grades (%)	Grade 3 (%)	Grade 4 (%)
Thrombocytopenia	70	9	4	31	1	0
Anemia	96	34	11	87	16	3
Neutropenia	19	5	2	4	<1	1

^a Presented values are worst Grade values regardless of baseline

^b National Cancer Institute Common Terminology Criteria for Adverse Events, version 3.0

Additional Data from the Placebo-Controlled Study

- 25% of patients treated with Jakafi and 7% of patients treated with placebo developed newly occurring or worsening Grade 1 abnormalities in alanine transaminase (ALT). The incidence of greater than or equal to Grade 2 elevations was 2% for Jakafi with 1% Grade 3 and no Grade 4 ALT elevations.
- 17% of patients treated with Jakafi and 6% of patients treated with placebo developed newly occurring or worsening Grade 1 abnormalities in aspartate transaminase (AST). The incidence of Grade 2 AST elevations was <1% for Jakafi with no Grade 3 or 4 AST elevations.
- 17% of patients treated with Jakafi and <1% of patients treated with placebo developed newly occurring or worsening Grade 1 elevations in cholesterol. The incidence of Grade 2 cholesterol elevations was <1% for Jakafi with no Grade 3 or 4 cholesterol elevations.

6.2 Clinical Trial Experience in Polycythemia Vera

In a randomized, open-label, active-controlled study, 110 patients with PV resistant to or intolerant of hydroxyurea received Jakafi and 111 patients received best available therapy [see *Clinical Studies (14.2)*]. The most frequent adverse reaction was anemia. Discontinuation for

adverse events, regardless of causality, was observed in 4% of patients treated with Jakafi. Table 13 presents the most frequent nonhematologic adverse reactions occurring up to Week 32.

Table 13: Polycythemia Vera: Nonhematologic Adverse Reactions Occurring in \geq 5% of Patients on Jakafi in the Open-Label, Active-controlled Study up to Week 32 of Randomized Treatment

Adverse Reactions	Jakafi (N=110)		Best Available Therapy (N=111)	
	All Grades ^a (%)	Grade 3-4 (%)	All Grades (%)	Grade 3-4 (%)
Diarrhea	15	0	7	<1
Dizziness ^b	15	0	13	0
Dyspnea ^c	13	3	4	0
Muscle Spasms	12	<1	5	0
Constipation	8	0	3	0
Herpes Zoster ^d	6	<1	0	0
Nausea	6	0	4	0
Weight Gain ^e	6	0	<1	0
Urinary Tract Infections ^f	6	0	3	0
Hypertension	5	<1	3	<1

^a National Cancer Institute Common Terminology Criteria for Adverse Events (CTCAE), version 3.0

^b includes dizziness and vertigo

^c includes dyspnea and dyspnea exertional

^d includes herpes zoster and post-herpetic neuralgia

^e includes weight increased and abnormal weight gain

^f includes urinary tract infection and cystitis

Clinically relevant laboratory abnormalities are shown in Table 14.

Table 14: Polycythemia Vera: Selected Laboratory Abnormalities in the Open-Label, Active-controlled Study up to Week 32 of Randomized Treatment^a

Laboratory Parameter	Jakafi (N=110)			Best Available Therapy (N=111)		
	All Grades ^b (%)	Grade 3 (%)	Grade 4 (%)	All Grades (%)	Grade 3 (%)	Grade 4 (%)
Hematology						
Anemia	72	<1	<1	58	0	0
Thrombocytopenia	27	5	<1	24	3	<1
Neutropenia	3	0	<1	10	<1	0
Chemistry						

Laboratory Parameter	Jakafi (N=110)			Best Available Therapy (N=111)		
	All Grades ^b (%)	Grade 3 (%)	Grade 4 (%)	All Grades (%)	Grade 3 (%)	Grade 4 (%)
Hypercholesterolemia	35	0	0	8	0	0
Elevated ALT	25	<1	0	16	0	0
Elevated AST	23	0	0	23	<1	0
Hypertriglyceridemia	15	0	0	13	0	0

^a Presented values are worst Grade values regardless of baseline

^b National Cancer Institute Common Terminology Criteria for Adverse Events, version 3.0

6.3 Clinical Trial Experience in Acute Graft-Versus-Host Disease

In a single-arm, open-label study, 71 adults (ages 18-73 years) were treated with Jakafi for acute GVHD failing treatment with steroids with or without other immunosuppressive drugs [see *Clinical Studies (14.3)*]. The median duration of treatment with Jakafi was 46 days (range, 4-382 days).

There were no fatal adverse reactions to Jakafi. An adverse reaction resulting in treatment discontinuation occurred in 31% of patients. The most common adverse reaction leading to treatment discontinuation was infection (10%). Table 15 shows the adverse reactions other than laboratory abnormalities.

Table 15: Acute Graft-Versus-Host Disease: Nonhematologic Adverse Reactions Occurring in $\geq 15\%$ of Patients in the Open-Label, Single-Cohort Study

Adverse Reactions ^a	Jakafi (N=71)	
	All Grades ^b (%)	Grade 3-4 (%)
Infections	55	41
Edema	51	13
Hemorrhage	49	20
Fatigue	37	14
Bacterial infections	32	28
Dyspnea	32	7
Viral infections	31	14
Thrombosis	25	11
Diarrhea	24	7
Rash	23	3
Headache	21	4
Hypertension	20	13
Dizziness	16	0

^a Selected laboratory abnormalities are listed in Table 16 below

^b National Cancer Institute Common Terminology Criteria for Adverse Events (CTCAE), version 4.03

Selected laboratory abnormalities during treatment with Jakafi are shown in Table 16.

Table 16: Acute Graft-Versus-Host Disease: Selected Laboratory Abnormalities Worsening from Baseline in the Open-Label, Single Cohort Study

	Jakafi (N=71)	
	Worst grade during treatment	
Laboratory Parameter	All Grades ^a (%)	Grade 3-4 (%)
Hematology		
Anemia	75	45
Thrombocytopenia	75	61
Neutropenia	58	40
Chemistry		
Elevated ALT	48	8
Elevated AST	48	6
Hypertriglyceridemia	11	1

^a National Cancer Institute Common Terminology Criteria for Adverse Events, version 4.03

7 DRUG INTERACTIONS

Fluconazole

Concomitant administration of Jakafi with fluconazole doses greater than 200 mg daily may increase ruxolitinib exposure due to inhibition of both the CYP3A4 and CYP2C9 metabolic pathways [see *Clinical Pharmacology (12.3)*]. Increased exposure may increase the risk of exposure-related adverse reactions. Avoid the concomitant use of Jakafi with fluconazole doses of greater than 200 mg daily except in patients with acute GVHD [see *Dosage and Administration (2.4)*].

Strong CYP3A4 inhibitors

Concomitant administration of Jakafi with strong CYP3A4 inhibitors increases ruxolitinib exposure [see *Clinical Pharmacology (12.3)*]. Increased exposure may increase the risk of exposure-related adverse reactions. Consider dose reduction when administering Jakafi with strong CYP3A4 inhibitors [see *Dosage and Administration (2.4)*]. In patients with acute GVHD, reduce Jakafi dose as recommended only when coadministered with ketoconazole, and monitor blood counts more frequently for toxicity and adjust the dose if necessary when coadministered with itraconazole [see *Dosage and Administration (2.4)*].

Strong CYP3A4 inducers

Concomitant administration of Jakafi with strong CYP3A4 inducers may decrease ruxolitinib exposure [see *Clinical Pharmacology* (12.3)]. No dose adjustment is recommended; however, monitor patients frequently and adjust the Jakafi dose based on safety and efficacy [see *Clinical Pharmacology* (12.3)].

8 USE IN SPECIFIC POPULATIONS

8.1 Pregnancy

Risk Summary

When pregnant rats and rabbits were administered ruxolitinib during the period of organogenesis adverse developmental outcomes occurred at doses associated with maternal toxicity (*see Data*). There are no studies with the use of Jakafi in pregnant women to inform drug-associated risks.

The background risk of major birth defects and miscarriage for the indicated populations is unknown. Adverse outcomes in pregnancy occur regardless of the health of the mother or the use of medications. The background risk in the U.S. general population of major birth defects is 2% to 4% and miscarriage is 15% to 20% of clinically recognized pregnancies.

Data

Animal Data

Ruxolitinib was administered orally to pregnant rats or rabbits during the period of organogenesis, at doses of 15, 30 or 60 mg/kg/day in rats and 10, 30 or 60 mg/kg/day in rabbits. There were no treatment-related malformations. Adverse developmental outcomes, such as decreases of approximately 9% in fetal weights were noted in rats at the highest and maternally toxic dose of 60 mg/kg/day. This dose results in an exposure (AUC) that is approximately 2 times the clinical exposure at the maximum recommended dose of 25 mg twice daily. In rabbits, lower fetal weights of approximately 8% and increased late resorptions were noted at the highest and maternally toxic dose of 60 mg/kg/day. This dose is approximately 7% the clinical exposure at the maximum recommended dose.

In a pre- and post-natal development study in rats, pregnant animals were dosed with ruxolitinib from implantation through lactation at doses up to 30 mg/kg/day. There were no drug-related adverse findings in pups for fertility indices or for maternal or embryofetal survival, growth and development parameters at the highest dose evaluated (34% the clinical exposure at the maximum recommended dose of 25 mg twice daily).

8.2 Lactation

Risk Summary

No data are available regarding the presence of ruxolitinib in human milk, the effects on the breast fed child, or the effects on milk production. Ruxolitinib and/or its metabolites were present in the milk of lactating rats (*see Data*). Because many drugs are present in human milk

and because of the potential for thrombocytopenia and anemia shown for Jakafi in human studies, discontinue breastfeeding during treatment with Jakafi and for two weeks after the final dose.

Data

Animal Data

Lactating rats were administered a single dose of [¹⁴C]-labeled ruxolitinib (30 mg/kg) on postnatal Day 10, after which plasma and milk samples were collected for up to 24 hours. The AUC for total radioactivity in milk was approximately 13-fold the maternal plasma AUC. Additional analysis showed the presence of ruxolitinib and several of its metabolites in milk, all at levels higher than those in maternal plasma.

8.4 Pediatric Use

The safety and effectiveness of Jakafi for treatment of myelofibrosis or polycythemia vera in pediatric patients have not been established.

The safety and effectiveness of Jakafi for treatment of steroid-refractory acute graft-versus-host disease (GVHD) have been established for treatment of children 12 years and older. Use of Jakafi in pediatric patients with steroid-refractory acute GVHD is supported by evidence from an adequate and well-controlled trial of Jakafi in adults [*see Clinical Studies (14.3)*] and additional pharmacokinetic and safety data in pediatric patients.

Jakafi was evaluated in a single-arm, dose-escalation study (NCT01164163) in 27 pediatric patients with relapsed or refractory solid tumors (Cohort A) and 20 with leukemias or myeloproliferative neoplasms (Cohort B). The patients had a median age of 14 years (range, 2 to 21 years) and included 18 children (age 2 to <12 years), and 14 adolescents (age 12 to <17 years). The dose levels tested were 15, 21, 29, 39, or 50 mg/m² twice daily in 28-day cycles with up to 6 patients per dose group.

Overall, 38 (81%) patients were treated with no more than a single cycle of Jakafi, while 3, 1, 2, and 3 patients received 2, 3, 4, and 5 or more cycles, respectively. A protocol-defined maximal tolerated dose was not observed, but since few patients were treated for multiple cycles, tolerability with continued use was not assessed adequately to establish a recommended Phase 2 dose higher than the recommended dose for adults. The safety profile in children was similar to that seen in adults.

Juvenile Animal Toxicity Data

Administration of ruxolitinib to juvenile rats resulted in effects on growth and bone measures. When administered starting at postnatal day 7 (the equivalent of a human newborn) at doses of 1.5 to 75 mg/kg/day, evidence of fractures occurred at doses \geq 30 mg/kg/day, and effects on body weight and other bone measures [e.g., bone mineral content, peripheral quantitative computed tomography, and x-ray analysis] occurred at doses \geq 5 mg/kg/day. When administered starting at postnatal day 21 (the equivalent of a human 2-3 years of age) at doses of 5 to 60 mg/kg/day, effects on body weight and bone occurred at doses \geq 15 mg/kg/day, which were considered adverse at 60 mg/kg/day. Males were more severely affected than females in all age groups, and effects were generally more severe when administration was initiated earlier in the

postnatal period. These findings were observed at exposures that are at least 27% the clinical exposure at the maximum recommended dose of 25 mg twice daily.

8.5 Geriatric Use

Of the total number of patients with MF in clinical studies with Jakafi, 52% were 65 years and older, while 15% were 75 years and older. No overall differences in safety or effectiveness of Jakafi were observed between these patients and younger patients.

Clinical studies of Jakafi in patients with acute GVHD did not include sufficient numbers of subjects age 65 and over to determine whether they respond differently from younger subjects.

8.6 Renal Impairment

Total exposure of ruxolitinib and its active metabolites increased with moderate (CL_{cr} 30 mL/min to 59 mL/min) and severe (CL_{cr} 15 mL/min to 29 mL/min) renal impairment, and ESRD on dialysis [see *Clinical Pharmacology* (12.3)]. Reduce Jakafi dose as recommended [see *Dosage and Administration* (2.5)].

8.7 Hepatic Impairment

Exposure of ruxolitinib increased with mild (Child-Pugh A), moderate (Child-Pugh B) and severe (Child-Pugh C) hepatic impairment [see *Clinical Pharmacology* (12.3)].

Reduce Jakafi dose as recommended in patients with MF or PV and any hepatic impairment [see *Dosage and Administration* (2.5)].

Monitor blood counts more frequently for toxicity and consider 5 mg once daily for patients with Stage 3 or 4 liver GVHD [see *Dosage and Administration* (2.5) and *Clinical Pharmacology* (12.3)].

10 OVERDOSAGE

There is no known antidote for overdoses with Jakafi. Single doses up to 200 mg have been given with acceptable acute tolerability. Higher than recommended repeat doses are associated with increased myelosuppression including leukopenia, anemia and thrombocytopenia. Appropriate supportive treatment should be given.

Hemodialysis is not expected to enhance the elimination of Jakafi.

11 DESCRIPTION

Ruxolitinib phosphate is a kinase inhibitor with the chemical name (*R*)-3-(4-(7*H*-pyrrolo[2,3-*d*]pyrimidin-4-yl)-1*H*-pyrazol-1-yl)-3-cyclopentylpropanenitrile phosphate and a molecular weight of 404.36. Ruxolitinib phosphate has the following structural formula:

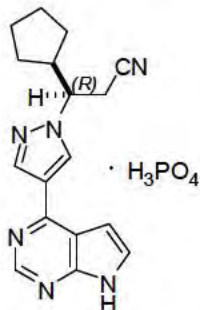

Ruxolitinib phosphate is a white to off-white to light pink powder and is soluble in aqueous buffers across a pH range of 1 to 8.

Jakafi (ruxolitinib) Tablets are for oral administration. Each tablet contains ruxolitinib phosphate equivalent to 5 mg, 10 mg, 15 mg, 20 mg and 25 mg of ruxolitinib free base together with microcrystalline cellulose, lactose monohydrate, magnesium stearate, colloidal silicon dioxide, sodium starch glycolate, povidone and hydroxypropyl cellulose.

12 CLINICAL PHARMACOLOGY

12.1 Mechanism of Action

Ruxolitinib, a kinase inhibitor, inhibits Janus Associated Kinases (JAKs) JAK1 and JAK2 which mediate the signaling of a number of cytokines and growth factors that are important for hematopoiesis and immune function. JAK signaling involves recruitment of STATs (signal transducers and activators of transcription) to cytokine receptors, activation and subsequent localization of STATs to the nucleus leading to modulation of gene expression.

MF and PV are myeloproliferative neoplasms (MPN) known to be associated with dysregulated JAK1 and JAK2 signaling. In a mouse model of JAK2V617F-positive MPN, oral administration of ruxolitinib prevented splenomegaly, preferentially decreased JAK2V617F mutant cells in the spleen and decreased circulating inflammatory cytokines (e.g., TNF- α , IL-6).

JAK-STAT signaling pathways play a role in regulating the development, proliferation, and activation of several immune cell types important for GVHD pathogenesis. In a mouse model of acute GVHD, oral administration of ruxolitinib was associated with decreased expression of inflammatory cytokines in colon homogenates and reduced immune-cell infiltration in the colon.

12.2 Pharmacodynamics

Jakafi inhibits cytokine induced STAT3 phosphorylation in whole blood from patients with MF and PV. Jakafi administration resulted in maximal inhibition of STAT3 phosphorylation 2 hours after dosing which returned to near baseline by 10 hours in patients with MF and PV.

Cardiac Electrophysiology

At a dose of 1.25 to 10 times the highest recommended starting dosage, Jakafi does not prolong the QT interval to any clinically relevant extent.

12.3 Pharmacokinetics

Mean ruxolitinib maximal plasma concentration (C_{\max}) and AUC increased proportionally over a single dose range of 5 mg to 200 mg. Mean ruxolitinib C_{\max} ranged from 205 nM to 7100 nM and AUC ranged from 862 nM*hr to 30700 nM*hr over a single dose range of 5 mg to 200 mg.

Absorption

Ruxolitinib achieves C_{\max} within 1 hour to 2 hours post-dose. Oral absorption of ruxolitinib is estimated to be at least 95%.

Food Effect

No clinically relevant changes in the pharmacokinetics of ruxolitinib were observed upon administration of Jakafi with a high-fat, high-calorie meal (approximately 800 to 1000 calories of which 50% were derived from fat).

Distribution

The mean volume of distribution at steady-state is 72 L (coefficient of variation [CV] 29%) in patients with MF and 75 L (23%) in patients with PV.

Binding to plasma proteins is approximately 97%, mostly to albumin.

Elimination

The mean elimination half-life of ruxolitinib is approximately 3 hours and the mean half-life of ruxolitinib + metabolites is approximately 5.8 hours.

Ruxolitinib clearance (% coefficient of variation, CV) was 17.7 L/h in women and 22.1 L/h in men with MF (39%).

Ruxolitinib clearance (%CV) was 12.7 L/h (42%) in patients with PV.

Ruxolitinib clearance (%CV) was 11.9 L/h (43%) in patients with acute GVHD.

Metabolism

Ruxolitinib is metabolized by CYP3A4 and to a lesser extent by CYP2C9.

Excretion

Following a single oral dose of radiolabeled ruxolitinib, elimination was predominately through metabolism with 74% of radioactivity excreted in urine and 22% excretion via feces. Unchanged drug accounted for less than 1% of the excreted total radioactivity.

Specific Populations

No clinically relevant differences in ruxolitinib pharmacokinetics were observed with regard to age, race, sex, or weight. No clinically relevant effect in ruxolitinib pharmacokinetics were observed with regards to any hepatic impairment (total bilirubin >ULN and any aspartate transferase) in patients with acute GVHD.

Patients with Renal Impairment

Following oral administration of a single dose of Jakafi 25 mg, the total AUC of ruxolitinib and its active metabolites increased by 1.3-, 1.5-, and 1.9-fold in subjects with mild, moderate, and severe renal impairment, respectively, compared to that in subjects with normal renal function (CL_{Cr} ≥ 90 mL/min). Also, the total AUC of ruxolitinib and its active metabolites increased by 1.6-fold in subjects with ESRD after dialysis compared to that in subjects with normal renal function (CL_{Cr} ≥ 90 mL/min). The pharmacokinetics of ruxolitinib was similar in subjects with various degrees of renal impairment and in those with normal renal function. The change in the pharmacodynamic marker, pSTAT3 inhibition, was consistent with the corresponding increase in metabolite exposure with renal impairment. Ruxolitinib is not removed by dialysis; however, the removal of some active metabolites by dialysis cannot be ruled out.

Patients with Hepatic Impairment

Following oral administration of a single dose of Jakafi 25 mg, the AUC of ruxolitinib increased in subjects with mild (Child-Pugh A) by 1.9-fold, moderate (Child-Pugh B) by 1.3-fold, and severe (Child-Pugh C) hepatic impairment by 1.7-fold compared to that in subjects with normal hepatic function.

The change in the pharmacodynamic marker, pSTAT3 inhibition, was consistent with the corresponding increase in ruxolitinib exposure except in the severe hepatic impairment cohort where the pharmacodynamic activity was more prolonged in some subjects than expected based on plasma concentrations of ruxolitinib.

Drug Interactions

Fluconazole

Simulations suggest that fluconazole (a dual CYP3A4 and CYP2C9 inhibitor) increases steady state ruxolitinib AUC by approximately 100% to 300% following concomitant administration of 10 mg of Jakafi twice daily with 100 mg to 400 mg of fluconazole once daily [*see Dosage and Administration (2.4) and Drug Interactions (7)*].

Strong CYP3A4 inhibitors

Ketoconazole (a strong CYP3A4 inhibitor) increased ruxolitinib C_{max} by 33% and AUC by 91%. Ketoconazole also prolonged ruxolitinib half-life from 3.7 hours to 6 hours [*see Dosage and Administration (2.4) and Drug Interactions (7)*].

Moderate CYP3A4 inhibitors

Erythromycin (a moderate CYP3A4 inhibitor) increased ruxolitinib C_{max} by 8% and AUC by 27% [*see Drug Interactions (7)*].

Strong CYP3A4 inducers

Rifampin (a strong CYP3A4 inducer) decreased ruxolitinib C_{max} by 32% and AUC by 61%. The relative exposure to ruxolitinib's active metabolites increased approximately 100% [*see Drug Interactions (7)*].

In vitro studies

Ruxolitinib and its M18 metabolite did not inhibit CYP1A2, CYP2B6, CYP2C8, CYP2C9, CYP2C19, CYP2D6 or CYP3A4. Ruxolitinib did not induce CYP1A2, CYP2B6 or CYP3A4 at clinically relevant concentrations.

Ruxolitinib and its M18 metabolite did not inhibit the P-gp, BCRP, OATP1B1, OATP1B3, OCT1, OCT2, OAT1 or OAT3 transport systems at clinically relevant concentrations. Ruxolitinib is not a substrate for the P-gp transporter.

13 NONCLINICAL TOXICOLOGY

13.1 Carcinogenesis, Mutagenesis, Impairment of Fertility

Ruxolitinib was not carcinogenic in the 6-month Tg.rasH2 transgenic mouse model or in a 2-year carcinogenicity study in the rat.

Ruxolitinib was not mutagenic in a bacterial mutagenicity assay (Ames test) or clastogenic in *in vitro* chromosomal aberration assay (cultured human peripheral blood lymphocytes) or *in vivo* in a rat bone marrow micronucleus assay.

In a fertility study, ruxolitinib was administered to male rats prior to and throughout mating and to female rats prior to mating and up to the implantation day (gestation day 7). Ruxolitinib had no effect on fertility or reproductive function in male or female rats at doses of 10, 30 or 60 mg/kg/day. However, in female rats doses of greater than or equal to 30 mg/kg/day resulted in increased post-implantation loss. The exposure (AUC) at the dose of 30 mg/kg/day is approximately 34% the clinical exposure at the maximum recommended dose of 25 mg twice daily.

14 CLINICAL STUDIES

14.1 Myelofibrosis

Two randomized Phase 3 studies (Studies 1 and 2) were conducted in patients with MF (either primary MF, post-polycythemia vera MF or post-essential thrombocythemia-MF). In both studies, patients had palpable splenomegaly at least 5 cm below the costal margin and risk category of intermediate 2 (2 prognostic factors) or high risk (3 or more prognostic factors) based on the International Working Group Consensus Criteria (IWG).

The starting dose of Jakafi was based on platelet count. Patients with a platelet count between 100 and 200 X 10⁹/L were started on Jakafi 15 mg twice daily and patients with a platelet count greater than 200 X 10⁹/L were started on Jakafi 20 mg twice daily. Doses were then individualized based upon tolerability and efficacy with maximum doses of 20 mg twice daily for patients with platelet counts between 100 to less than or equal to 125 X 10⁹/L, of 10 mg twice daily for patients with platelet counts between 75 to less than or equal to 100 X 10⁹/L, and of 5 mg twice daily for patients with platelet counts between 50 to less than or equal to 75 X 10⁹/L.

Study 1

Study 1 (NCT00952289) was a double-blind, randomized, placebo-controlled study in 309 patients who were refractory to or were not candidates for available therapy. The median age was 68 years (range 40 to 91 years) with 61% of patients older than 65 years and 54% were male. Fifty percent (50%) of patients had primary MF, 31% had post-polycythemia vera MF and 18% had post-essential thrombocythemia MF. Twenty-one percent (21%) of patients had red blood cell transfusions within 8 weeks of enrollment in the study. The median hemoglobin count was 10.5 g/dL and the median platelet count was $251 \times 10^9/L$. Patients had a median palpable spleen length of 16 cm below the costal margin, with 81% having a spleen length 10 cm or greater below the costal margin. Patients had a median spleen volume as measured by magnetic resonance imaging (MRI) or computed tomography (CT) of 2595 cm^3 (range 478 cm^3 to 8881 cm^3). (The upper limit of normal is approximately 300 cm^3).

Patients were dosed with Jakafi or matching placebo. The primary efficacy endpoint was the proportion of patients achieving greater than or equal to a 35% reduction from baseline in spleen volume at Week 24 as measured by MRI or CT.

Secondary endpoints included duration of a 35% or greater reduction in spleen volume and proportion of patients with a 50% or greater reduction in Total Symptom Score from baseline to Week 24 as measured by the modified Myelofibrosis Symptom Assessment Form (MFSAF) v2.0 diary.

Study 2

Study 2 (NCT00934544) was an open-label, randomized study in 219 patients. Patients were randomized 2:1 to Jakafi versus best available therapy. Best available therapy was selected by the investigator on a patient-by-patient basis. In the best available therapy arm, the medications received by more than 10% of patients were hydroxyurea (47%) and glucocorticoids (16%). The median age was 66 years (range 35 to 85 years) with 52% of patients older than 65 years and 57% were male. Fifty-three percent (53%) of patients had primary MF, 31% had post-polycythemia vera MF and 16% had post-essential thrombocythemia MF. Twenty-one percent (21%) of patients had red blood cell transfusions within 8 weeks of enrollment in the study. The median hemoglobin count was 10.4 g/dL and the median platelet count was $236 \times 10^9/L$. Patients had a median palpable spleen length of 15 cm below the costal margin, with 70% having a spleen length 10 cm or greater below the costal margin. Patients had a median spleen volume as measured by MRI or CT of 2381 cm^3 (range 451 cm^3 to 7765 cm^3).

The primary efficacy endpoint was the proportion of patients achieving 35% or greater reduction from baseline in spleen volume at Week 48 as measured by MRI or CT.

A secondary endpoint in Study 2 was the proportion of patients achieving a 35% or greater reduction of spleen volume as measured by MRI or CT from baseline to Week 24.

Study 1 and 2 Efficacy Results

Efficacy analyses of the primary endpoint in Studies 1 and 2 are presented in [Table 17](#) below. A significantly larger proportion of patients in the Jakafi group achieved a 35% or greater reduction in spleen volume from baseline in both studies compared to placebo in Study 1 and best available

therapy in Study 2. A similar proportion of patients in the Jakafi group achieved a 50% or greater reduction in palpable spleen length.

Table 17: Percent of Patients with Myelofibrosis Achieving 35% or Greater Reduction from Baseline in Spleen Volume at Week 24 in Study 1 and at Week 48 in Study 2 (Intent to Treat)

	Study 1		Study 2	
	Jakafi (N=155)	Placebo (N=154)	Jakafi (N=146)	Best Available Therapy (N=73)
Time Points	Week 24		Week 48	
Number (%) of Patients with Spleen Volume Reduction by 35% or More	65 (42)	1 (<1)	41 (29)	0
P-value	< 0.0001		< 0.0001	

Figure 1 shows the percent change from baseline in spleen volume for each patient at Week 24 (Jakafi N=139, placebo N=106) or the last evaluation prior to Week 24 for patients who did not complete 24 weeks of randomized treatment (Jakafi N=16, placebo N=47). One (1) patient (placebo) with a missing baseline spleen volume is not included.

Figure 1: Percent Change from Baseline in Spleen Volume at Week 24 or Last Observation for Each Patient (Study 1)

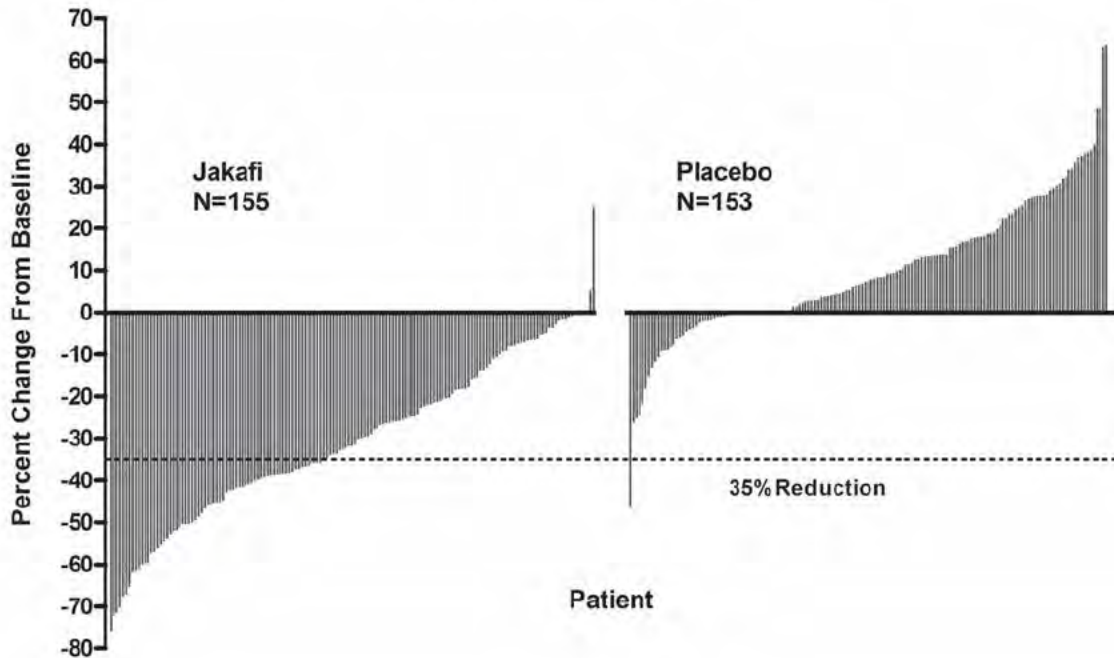

In Study 1, MF symptoms were a secondary endpoint and were measured using the modified Myelofibrosis Symptom Assessment Form (MFSAF) v2.0 diary. The modified MFSAF is a daily diary capturing the core symptoms of MF (abdominal discomfort, pain under left ribs, night sweats, itching, bone/muscle pain and early satiety). Symptom scores ranged from 0 to 10 with 0 representing symptoms “absent” and 10 representing “worst imaginable” symptoms. These scores were added to create the daily total score, which has a maximum of 60.

Table 18 presents assessments of Total Symptom Score from baseline to Week 24 in Study 1 including the proportion of patients with at least a 50% reduction (ie, improvement in symptoms). At baseline, the mean Total Symptom Score was 18.0 in the Jakafi group and 16.5 in the placebo group. A higher proportion of patients in the Jakafi group had a 50% or greater reduction in Total Symptom Score than in the placebo group, with a median time to response of less than 4 weeks.

Table 18: Improvement in Total Symptom Score in Patients with Myelofibrosis

	Jakafi (N=148)	Placebo (N=152)
Number (%) of Patients with 50% or Greater Reduction in Total Symptom Score by Week 24	68 (46)	8 (5)
P-value	< 0.0001	

Figure 2 shows the percent change from baseline in Total Symptom Score for each patient at Week 24 (Jakafi N=129, placebo N=103) or the last evaluation on randomized therapy prior to Week 24 for patients who did not complete 24 weeks of randomized treatment (Jakafi N=16, placebo N=42). Results are excluded for 5 patients with a baseline Total Symptom Score of zero, 8 patients with missing baseline and 6 patients with insufficient post-baseline data.

Figure 2: Percent Change from Baseline in Total Symptom Score at Week 24 or Last Observation for Each Patient (Study 1)

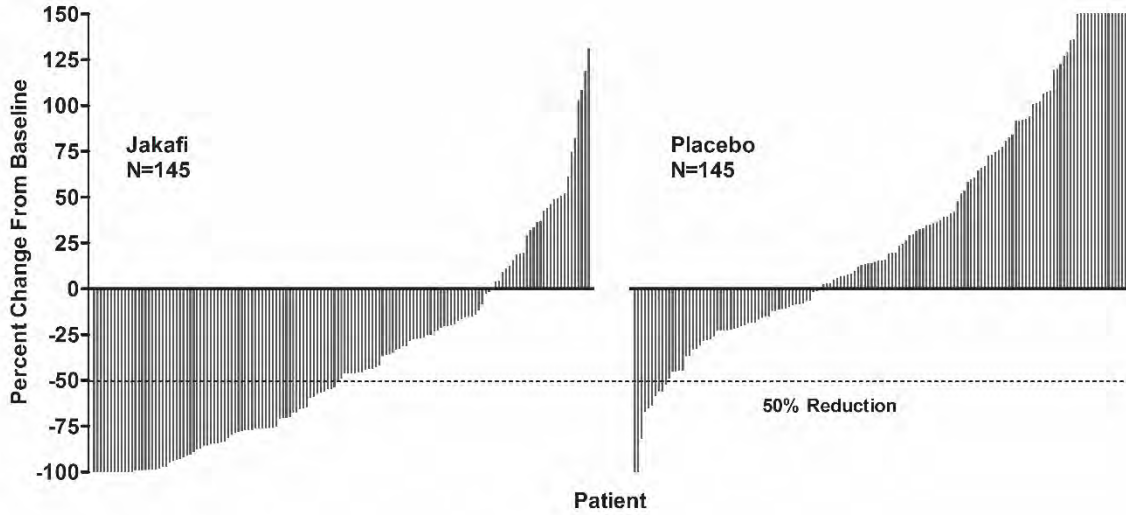

Worsening of Total Symptom Score is truncated at 150%.

Figure 3 displays the proportion of patients with at least a 50% improvement in each of the individual symptoms that comprise the Total Symptom Score indicating that all 6 of the symptoms contributed to the higher Total Symptom Score response rate in the group treated with Jakafi.

Figure 3: Proportion of Patients with Myelofibrosis Achieving 50% or Greater Reduction in Individual Symptom Scores at Week 24

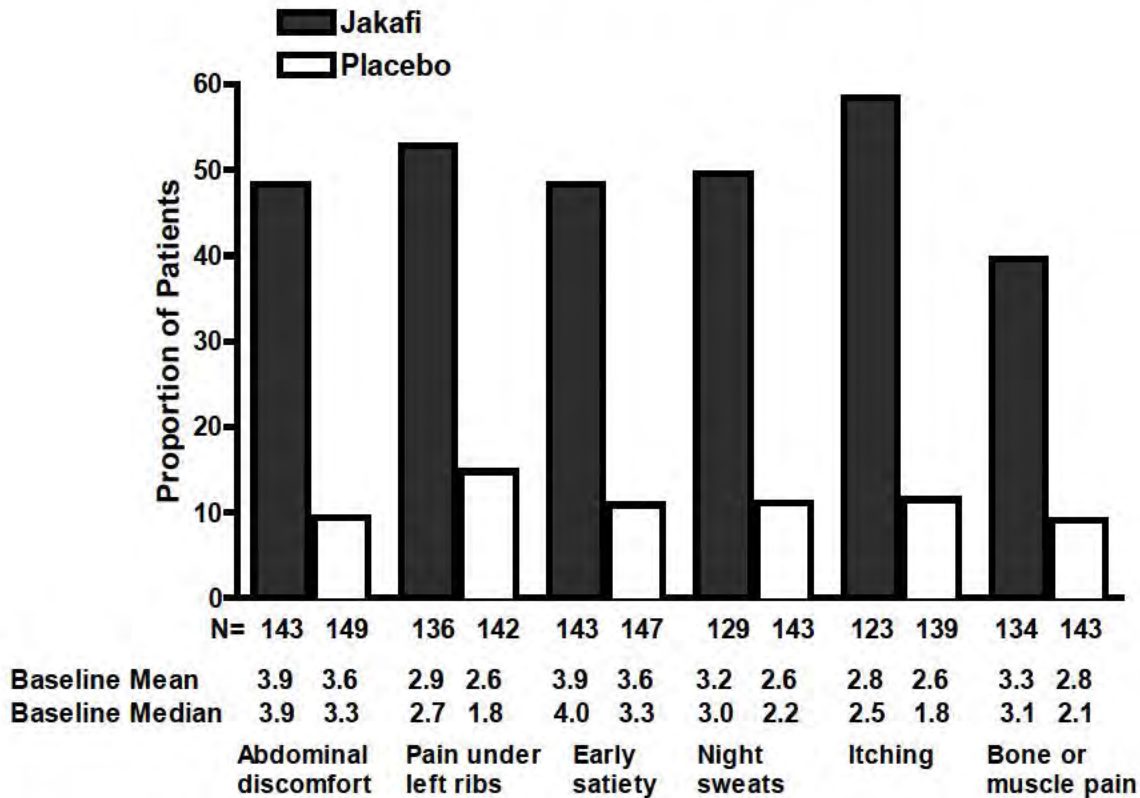

Individual score range = 0 to 10

An exploratory analysis of patients receiving Jakafi also showed improvement in fatigue-related symptoms (i.e., tiredness, exhaustion, mental tiredness, and lack of energy) and associated impacts on daily activities (i.e., activity limitations related to work, self-care, and exercise) as measured by the PROMIS® Fatigue 7-item short form total score at Week 24. Patients who achieved a reduction of 4.5 points or more from baseline to Week 24 in the PROMIS® Fatigue total score were considered to have achieved a fatigue response. Fatigue response was reported in 35% of patients in the Jakafi group versus 14% of the patients in the placebo group.

Overall survival was a secondary endpoint in both Study 1 and Study 2. Patients in the control groups were eligible for crossover in both studies, and the median times to crossover were 9 months in Study 1 and 17 months in Study 2.

Figure 4 and Figure 5 show Kaplan-Meier curves of overall survival at prospectively planned analyses after all patients remaining on study had completed 144 weeks on study.

Figure 4: Overall Survival - Kaplan-Meier Curves by Treatment Group in Study 1

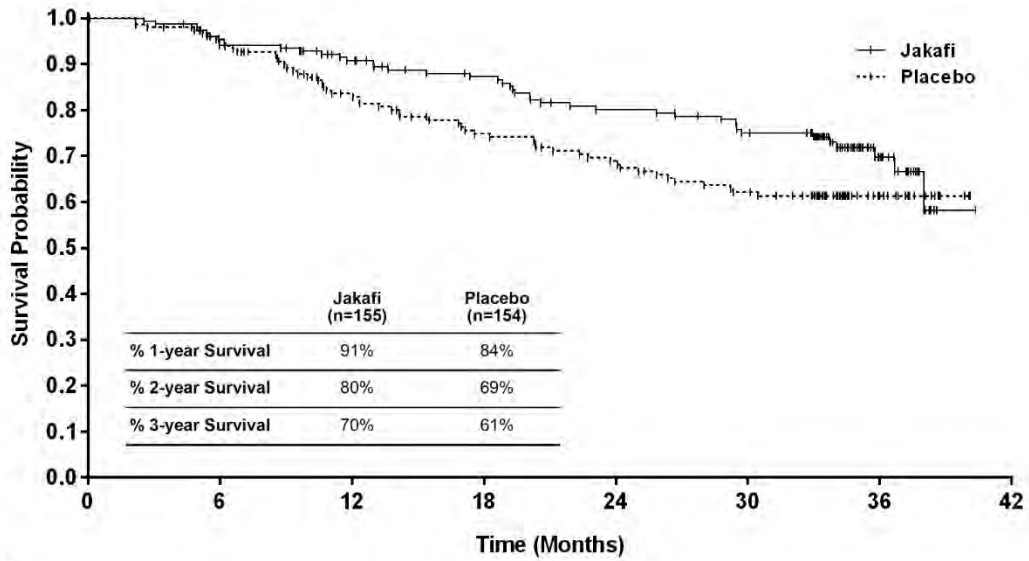

Number at Risk:

	0	6	12	18	24	30	36	42
Jakafi	155	145	134	122	111	102	29	0
Placebo	154	142	117	101	92	82	32	0

Figure 5: Overall Survival - Kaplan-Meier Curves by Treatment Group in Study 2

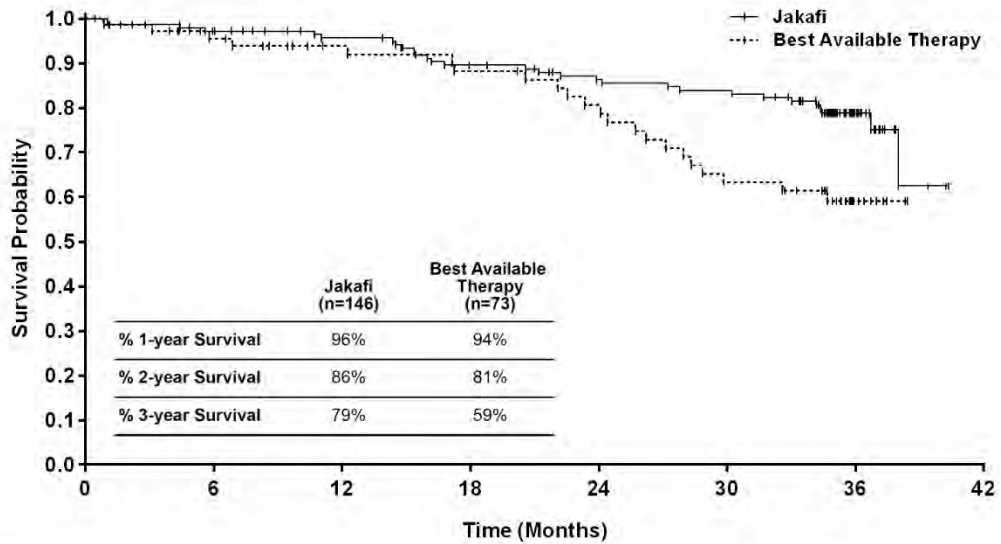

Number at Risk:

	0	6	12	18	24	30	36	42
Jakafi	146	135	126	115	107	104	33	0
Best Available Therapy	73	58	50	47	42	33	9	0

14.2 Polycythemia Vera

Study 3 (NCT01243944) was a randomized, open-label, active-controlled Phase 3 study conducted in 222 patients with PV. Patients had been diagnosed with PV for at least 24 weeks, had an inadequate response to or were intolerant of hydroxyurea, required phlebotomy and exhibited splenomegaly. All patients were required to demonstrate hematocrit control between 40-45% prior to randomization. The age ranged from 33 to 90 years with 30% of patients over 65 years of age and 66% were male. Patients had a median spleen volume as measured by MRI or CT of 1272 cm³ (range 254 cm³ to 5147 cm³) and median palpable spleen length below the costal margin was 7 cm.

Patients were randomized to Jakafi or best available therapy. The starting dose of Jakafi was 10 mg twice daily. Doses were then individualized based upon tolerability and efficacy with a maximum dose of 25 mg twice daily. At Week 32, 98 patients were still on Jakafi with 8% receiving greater than 20 mg twice daily, 15% receiving 20 mg twice daily, 33% receiving 15 mg twice daily, 34% receiving 10 mg twice daily, and 10% receiving less than 10 mg twice daily. Best available therapy (BAT) was selected by the investigator on a patient-by-patient basis and included hydroxyurea (60%), interferon/pegylated interferon (12%), anagrelide (7%), pipobroman (2%), lenalidomide/thalidomide (5%), and observation (15%).

The primary endpoint was the proportion of subjects achieving a response at Week 32, with response defined as having achieved both hematocrit control (the absence of phlebotomy eligibility beginning at the Week 8 visit and continuing through Week 32) and spleen volume reduction (a greater than or equal to 35% reduction from baseline in spleen volume at Week 32). Phlebotomy eligibility was defined as a confirmed hematocrit greater than 45% that is at least 3 percentage points higher than the hematocrit obtained at baseline or a confirmed hematocrit greater than 48%, whichever was lower. Secondary endpoints included the proportion of all randomized subjects who achieved the primary endpoint and who maintained their response 48 weeks after randomization, and the proportion of subjects achieving complete hematological remission at Week 32 with complete hematological remission defined as achieving hematocrit control, platelet count less than or equal to 400 X 10⁹/L, and white blood cell count less than or equal to 10 X 10⁹/L.

Results of the primary and secondary endpoints are presented in Table 19. A significantly larger proportion of patients on the Jakafi arm achieved a response for the primary endpoint compared to best available therapy at Week 32 and maintained their response 48 weeks after randomization. A significantly larger proportion of patients on the Jakafi arm compared to best available therapy also achieved complete hematological remission at Week 32.

Table 19: Percent of Patients with Polycythemia Vera Achieving the Primary and Key Secondary Endpoints in Study 3 (Intent to Treat)

	Jakafi (N=110)	Best Available Therapy (N=112)
Number (%) of Patients Achieving a Primary Response at Week 32	25 (23%)	1 (<1%)
95% CI of the response rate (%)	(15%, 32%)	(0%, 5%)

	Jakafi (N=110)	Best Available Therapy (N=112)
P-value	< 0.0001	
Number (%) of Patients Achieving a Durable Primary Response at Week 48	22 (20%)	1 (<1%)
95% CI of the response rate (%)	(13%, 29%)	(0%, 5%)
P-value	< 0.0001	
Number (%) of Patients Achieving Complete Hematological Remission at Week 32	26 (24%)	9 (8%)
95% CI of the response rate (%)	(16%, 33%)	(4%, 15%)
P-value	0.0016	

Primary Response defined as having achieved both the absence of phlebotomy eligibility beginning at the Week 8 visit and continuing through Week 32 and a greater than or equal to 35% reduction from baseline in spleen volume at Week 32.

Additional analyses for Study 3 to assess durability of response were conducted at Week 80 only in the Jakafi arm. On this arm, 91 (83%) patients were still on treatment at the time of the Week 80 data cut-off. Of the 25 patients who achieved a primary response at Week 32, 19 (76% of the responders) maintained their response through Week 80, and of the 26 patients who achieved complete hematological remission at Week 32, 15 (58% of the responders) maintained their response through Week 80.

In an assessment of the individual components that make up the primary endpoint, there were 66 (60%) patients with hematocrit control on the Jakafi arm vs. 21 (19%) patients on best available therapy at Week 32; 51 (77% of hematocrit responders) patients on the Jakafi arm maintained hematocrit control through Week 80. There were 44 (40%) patients with spleen volume reduction from baseline greater than or equal to 35% on the Jakafi arm vs. 1 (<1%) patient on best available therapy at Week 32; 43 (98% of spleen volume reduction responders) patients on the Jakafi arm maintained spleen volume reduction through Week 80.

14.3 Acute Graft-Versus-Host Disease

Study 4 (NCT02953678) was an open-label, single-arm, multicenter study of Jakafi for treatment of patients with steroid-refractory acute GVHD Grades 2 to 4 (Mount Sinai Acute GVHD International Consortium (MAGIC) criteria) occurring after allogeneic hematopoietic stem cell transplantation. Jakafi was administered at 5 mg twice daily, and the dose could be increased to 10 mg twice daily after 3 days in the absence of toxicity.

There were 49 patients with acute GVHD refractory to steroids alone. These patients had a median age of 57 years (range, 18-72 years), 47% were male, 92% were Caucasian, and 14% were Hispanic. At baseline, acute GVHD was Grade 2 in 27%, Grade 3 in 55%, and Grade 4 in 18%; 84% had visceral GVHD; the median MAGIC biomarker score was 0.47 (range, 0.10-0.92); and the median ST2 level was 334 mcg/L (range, 55-1286 mcg/L). The median duration of prior corticosteroid exposure at baseline was 15 days (range: 3 – 106 days).

The efficacy of Jakafi was based on Day-28 overall response rate (ORR) (complete response, very good partial response or partial response by Center for International Blood and Marrow Transplant Research (CIBMTR) criteria) and the duration of response. The ORR results are presented in Table 20; Day-28 ORR was 100% for Grade 2 GVHD, 40.7% for Grade 3 GVHD, and 44.4% for Grade 4 GVHD. The median duration of response, calculated from Day-28 response to progression, new salvage therapy for acute GVHD or death from any cause (with progression being defined as worsening by one stage in any organ without improvement in other organs in comparison to prior response assessment) was 16 days (95% CI 9, 83). Also for the Day-28 responders, the median time from Day-28 response to either death or need for new therapy for acute GVHD (additional salvage therapy or increase in steroids) was 173 days (95% CI 66, NE).

Table 20: Day-28 Overall Response Rate for Patients with Steroid-Refractory Acute GVHD in Study 4

	Refractory to Steroids Alone (n=49)
Overall Response (%) (95% CI)	28 (57.1%) (42.2, 71.2)
Complete Response	15 (30.6%)
Very Good Partial Response	2 (4.1%)
Partial Response	11 (22.4%)

16 HOW SUPPLIED/STORAGE AND HANDLING

Jakafi (ruxolitinib) Tablets are available as follows:

Jakafi Trade Presentations

NDC Number	Strength	Description	Tablets per Bottle
50881-005-60	5 mg	Round tablet with "INCY" on one side and "5" on the other	60
50881-010-60	10 mg	Round tablet with "INCY" on one side and "10" on the other	60
50881-015-60	15 mg	Oval tablet with "INCY" on one side and "15" on the other	60
50881-020-60	20 mg	Capsule shaped tablet with "INCY" on one side and "20" on the other	60
50881-025-60	25 mg	Oval tablet with "INCY" on one side and "25" on the other	60

Store at room temperature 20°C to 25°C (68°F to 77°F); excursions permitted between 15°C and 30°C (59°F and 86°F) [see USP Controlled Room Temperature].

17 PATIENT COUNSELING INFORMATION

See FDA-approved patient labeling (Patient Information).

Discuss the following with patients prior to and during treatment with Jakafi:

Thrombocytopenia, Anemia and Neutropenia

Inform patients that Jakafi is associated with thrombocytopenia, anemia and neutropenia, and of the need to monitor complete blood counts before and during treatment. Advise patients to observe for and report bleeding.

Infections

Inform patients of the signs and symptoms of infection and to report any such signs and symptoms promptly.

Inform patients regarding the early signs and symptoms of herpes zoster and of progressive multifocal leukoencephalopathy, and advise patients to seek advice of a clinician if such symptoms are observed.

Symptom Exacerbation Following Interruption or Discontinuation of Treatment with Jakafi

Inform patients that after discontinuation of treatment, signs and symptoms from myeloproliferative neoplasms are expected to return. Instruct patients not to interrupt or discontinue Jakafi therapy without consulting their physician.

Non-Melanoma Skin Cancer

Inform patients that Jakafi may increase their risk of certain non-melanoma skin cancers. Advise patients to inform their healthcare provider if they have ever had any type of skin cancer or if they observe any new or changing skin lesions.

Lipid Elevations

Inform patients that Jakafi may increase blood cholesterol, and of the need to monitor blood cholesterol levels.

Drug-drug Interactions

Advise patients to inform their healthcare providers of all medications they are taking, including over-the-counter medications, herbal products and dietary supplements.

Dialysis

Inform patients on dialysis that their dose should not be taken before dialysis but only following dialysis.

Lactation

Inform women not to breastfeed during treatment with Jakafi and for two weeks after the final dose.

Compliance

Advise patients to continue taking Jakafi every day for as long as their physician tells them and that this is a long-term treatment. Patients should not change dose or stop taking Jakafi without first consulting their physician. Patients should be aware that after discontinuation of treatment, signs and symptoms from myeloproliferative neoplasms are expected to return.

Manufactured for:
Incyte Corporation
1801 Augustine Cut-off
Wilmington, DE 19803

Jakafi is a registered trademark of Incyte. All rights reserved.
U.S. Patent Nos. 7598257; 8415362; 8722693; 8822481; 8829013; 9079912; 9814722;
10016429
© 2011-2019 Incyte Corporation. All rights reserved.

Patient Information
JAKAFI® (JAK-ah-fye)
(ruxolitinib)
tablets

What is Jakafi?

Jakafi is a prescription medicine used to treat:

- adults with certain types of myelofibrosis (MF).
- adults with polycythemia vera (PV) who have already taken a medicine called hydroxyurea and it did not work well enough or they could not tolerate it
- adults and children 12 years of age and older with acute graft versus host disease (GVHD) who have taken corticosteroids and they did not work well enough.

It is not known if Jakafi is safe or effective in children for treatment of myelofibrosis or polycythemia vera.

Before taking Jakafi, tell your healthcare provider about of your medical conditions, including if you:

- have an infection
- have or had tuberculosis (TB), or have been in close contact with someone who has TB
- have or had hepatitis B
- have or have had liver problems
- have or have had kidney problems or are on dialysis. If you are on dialysis, Jakafi should be taken after your dialysis
- have high level of fat in your blood (high blood cholesterol or triglycerides)
- have had skin cancer in the past
- are pregnant or plan to become pregnant. It is not known if Jakafi will harm your unborn baby.
- are breastfeeding or plan to breastfeed. It is not known if Jakafi passes into your breast milk. Do not breastfeed during treatment with Jakafi and for 2 weeks after the final dose.

Tell your healthcare provider about all the medicines you take, including prescription and over-the-counter medicines, vitamins and herbal supplements. Taking Jakafi with certain other medicines may affect how Jakafi works. Know the medicines you take. Keep a list of them to show your healthcare provider and pharmacist when you get a new medicine.

How should I take Jakafi?

- Take Jakafi exactly as your healthcare provider tells you.
- Do not change your dose or stop taking Jakafi without first talking to your healthcare provider.
- You can take Jakafi with or without food.
- Jakafi may also be given through certain nasogastric tubes.
 - Tell your healthcare provider if you cannot take Jakafi by mouth. Your healthcare provider will decide if you can take Jakafi through a nasogastric tube.
 - Ask your healthcare provider to give you specific instruction on how to properly take Jakafi through a nasogastric tube.
- If you miss a dose of Jakafi, take your next dose at your regular time. Do not take 2 doses at the same time.
- If you take too much Jakafi call your healthcare provider or go to the nearest hospital emergency room right away.
- You will have regular blood tests during your treatment with Jakafi. Your healthcare provider may change your dose of Jakafi or stop your treatment based on the results of your blood tests.

What are the possible side effects of Jakafi?

Jakafi can cause serious side effects including:

Low blood cell counts. Jakafi may cause low platelet counts (thrombocytopenia), low red blood cell counts (anemia), and low white blood cell counts (neutropenia). If you develop bleeding, stop Jakafi and call your healthcare provider. Your healthcare provider will do a blood test to check your blood cell counts before you start Jakafi and regularly during your treatment with Jakafi. Tell your healthcare provider right away if you develop or have worsening of any of these symptoms:

- unusual bleeding
- shortness of breath
- bruising
- fever
- tiredness

Infection. You may be at risk for developing a serious infection during treatment with Jakafi. Tell your healthcare provider if you develop any of the following symptoms of infection:

- chills
- aches
- fever
- nausea
- vomiting
- weakness
- painful skin rash or blisters

Skin cancers. Some people who take Jakafi have developed certain types of non-melanoma skin cancers. Tell your healthcare provider if you develop any new or changing skin lesions during treatment with Jakafi.

Cholesterol increases. You may have changes in your blood cholesterol levels. Your healthcare provider will do blood tests to check your cholesterol levels during treatment with Jakafi.

The most common side effects of Jakafi in adults with certain types of MF and PV include:

- low platelet counts (thrombocytopenia)
- low red blood cell counts (anemia)
- bruising
- dizziness
- headache
- diarrhea

The most common side effects of Jakafi in people with acute graft versus host disease (GVHD) include:

- low red blood cell counts (anemia)
- low platelet counts (thrombocytopenia)
- low white blood cell counts (neutropenia)
- infections
- fluid retention

These are not all the possible side effects of Jakafi.

Call your doctor for medical advice about side effects. You may report side effects to FDA at 1-800-FDA-1088.

You may also report side effects to Incyte Corporation at 1-855-463-3463.

How should I store Jakafi?

- Store Jakafi at room temperature 68°F to 77°F (20°C to 25°C).

Keep Jakafi and all medicines out of the reach of children.

General information about the safe and effective use of Jakafi.

Medicines are sometimes prescribed for purposes other than those listed in Patient Information. Do not use Jakafi for a condition for which it is not prescribed. Do not give Jakafi to other people, even if they have the same symptoms you have. It may harm them. You can ask your pharmacist or healthcare provider for information that is written for healthcare professionals.

What are the ingredients in Jakafi?

Active ingredient: ruxolitinib phosphate

Inactive ingredients: microcrystalline cellulose, lactose monohydrate, magnesium stearate, colloidal silicon dioxide, sodium starch glycolate, povidone and hydroxypropyl cellulose

Manufactured for: Incyte Corporation, 1801 Augustine Cut-off, Wilmington, DE 19803

Jakafi is a registered trademark of Incyte. All rights reserved.

U.S. Patent Nos. 7598257; 8415362; 8722693; 8822481; 8829013; 9079912; 9814722; 10016429

© 2011-2019 Incyte Corporation. All rights reserved.

For more information call 1-855-463-3463 or go to www.jakafi.com.

This Patient Information has been approved by the U.S. Food and Drug Administration.

Revised January 2020

This is a representation of an electronic record that was signed electronically. Following this are manifestations of any and all electronic signatures for this electronic record.

/s/

ANN T FARRELL
01/14/2020 12:00:00 AM

PRODUCT MONOGRAPH

Pr JAKAVI[®]

(ruxolitinib tablets)
(as ruxolitinib phosphate)

5 mg, 10 mg, 15 mg and 20 mg

Antineoplastic agent

Novartis Pharmaceuticals Canada Inc.
385, Boulevard Bouchard
Dorval, Quebec, H9S 1A9

Date of revision
September 28, 2018

Control No: 216617

[®] Registered trademark

Table of Contents

PART I: HEALTH PROFESSIONAL INFORMATION.....3
SUMMARY PRODUCT INFORMATION3
INDICATIONS AND CLINICAL USE.....3
CONTRAINDICATIONS3
WARNINGS AND PRECAUTIONS.....4
ADVERSE REACTIONS.....9
DRUG INTERACTIONS21
DOSAGE AND ADMINISTRATION22
OVERDOSAGE26
ACTION AND CLINICAL PHARMACOLOGY26
STORAGE AND STABILITY29
SPECIAL HANDLING INSTRUCTIONS29

PART II: SCIENTIFIC INFORMATION31
PHARMACEUTICAL INFORMATION.....31
CLINICAL TRIALS.....33
DETAILED PHARMACOLOGY41
TOXICOLOGY43
REFERENCES.....46

PART III: CONSUMER INFORMATION.....48

Pr **JAKAVI**[®]

(ruxolitinib tablets)

PART I: HEALTH PROFESSIONAL INFORMATION

SUMMARY PRODUCT INFORMATION

Route of Administration	Dosage Form / Strength	Clinically Relevant Nonmedicinal Ingredients
Oral	Tablet 5 mg, 10 mg, 15 mg and 20 mg	Tablet content: Lactose monohydrate <i>For a complete listing see Dosage Forms, Composition and Packaging section.</i>

INDICATIONS AND CLINICAL USE

JAKAVI[®] is indicated for:

- the treatment of splenomegaly and/or its associated symptoms in adult patients with primary myelofibrosis (also known as chronic idiopathic myelofibrosis), post-polycythemia vera myelofibrosis or post-essential thrombocythemia myelofibrosis.
- the control of hematocrit in adult patients with polycythemia vera (PV) resistant to or intolerant of a cytoreductive agent.

JAKAVI[®] should be initiated and monitored by a physician experienced in the use of antineoplastic therapies.

Geriatrics (> 65 years of age):

No additional dose adjustments are recommended for elderly patients.

Pediatrics (< 18 years of age):

Safety and efficacy of JAKAVI[®] in pediatric patients have not been established.

CONTRAINDICATIONS

Patients with known hypersensitivity to ruxolitinib or to any ingredient in the formulation of JAKAVI[®] or component of the container. For a complete listing, see the **DOSAGE FORMS, COMPOSITION AND PACKAGING** section.

Patients who have or have had progressive multifocal leukoencephalopathy (PML) (see **WARNINGS AND PRECAUTIONS** section).

WARNINGS AND PRECAUTIONS

Serious Warnings and Precautions

Serious bacterial, mycobacterial, fungal and viral infections including viral reactivation and other opportunistic infections (in some cases life-threatening or fatal) have been reported in patients treated with JAKAVI.

Reported infections included: Tuberculosis, Herpes Zoster, JC Virus and Hepatitis B.

Patients should be carefully assessed and monitored for the risk of developing serious infections. (see **WARNINGS and PRECAUTIONS, ADVERSE DRUG REACTIONS and Post-Marketing Adverse Drug Reactions** sections).

General

Interactions

If JAKAVI[®] is to be co-administered with strong CYP3A4 inhibitors or concomitant administration of moderate inhibitors of CYP3A4 and CYP2C9 (including a dual enzyme inhibitor as a single agent, e.g. fluconazole), the dose should be reduced to approximately 50% of the dose, rounding up to the nearest dosage strength. More frequent monitoring is recommended (see **DOSAGE AND ADMINISTRATION, and DRUG INTERACTIONS** sections).

Withdrawal effects in patients with myelofibrosis (MF)

Following interruption or discontinuation of JAKAVI, symptoms of myelofibrosis may return over a period of approximately 1 week. There have been cases of MF patients discontinuing JAKAVI who sustained more severe events, particularly in the presence of acute intercurrent illness. It has not been established whether abrupt discontinuation of JAKAVI contributed to these events. Unless abrupt discontinuation is required, gradual tapering of the dose of JAKAVI may be considered, although the utility of the tapering is unproven.

Carcinogenesis and Mutagenesis

Non-Melanoma Skin Cancer

Non-melanoma skin cancers (NMSCs), including basal cell, squamous cell, and Merkel cell carcinoma have been reported in patients treated with JAKAVI. Most of these patients had histories of extended treatment with hydroxyurea and prior NMSC or pre-malignant skin lesions. A causal relationship to JAKAVI has not been established. Patients should minimize exposure to

risk factors for skin cancer such as exposure to sunlight and other UV emitting sources while on JAKAVI. Periodic skin examination is recommended for patients who are at increased risk for skin cancer.

Ruxolitinib was not carcinogenic in animal carcinogenic studies (see **TOXICOLOGY** section). Ruxolitinib did not test positive for mutagenicity or clastogenicity in the standard panel of genotoxicity assays (see **TOXICOLOGY** section).

Cardiovascular

Heart Rate Decrease and PR Interval Prolongation

JAKAVI causes a decrease in heart rate and a prolongation of the PR interval (see **WARNINGS AND PRECAUTIONS**, Monitoring and Laboratory Tests; **ADVERSE REACTIONS**, Electrocardiography sections). Caution should be observed in patients with a low heart rate at baseline (< 60 beats per minute), a history of syncope or arrhythmia, sick sinus syndrome, sinoatrial block, atrioventricular (AV) block, ischemic heart disease, or congestive heart failure. Concomitant medications that result in a decrease in heart rate and/or PR interval prolongation should be avoided to the extent possible during treatment with JAKAVI (see **DRUG INTERACTIONS** section).

Lipid Abnormalities/ Elevations

Treatment with JAKAVI has been associated with increases in lipid parameters including total cholesterol, low-density lipoprotein (LDL) cholesterol, and triglycerides. Lipid monitoring and treatment of dyslipidemia according to clinical guidelines is recommended (see **Monitoring and Laboratory Tests** section).

Hematologic

Decrease in blood cell count

Treatment with JAKAVI can cause hematological adverse reactions, including thrombocytopenia, anemia and neutropenia. A complete blood count must be performed before initiating therapy with JAKAVI and during therapy (see **WARNINGS AND PRECAUTIONS**, **Monitoring and Laboratory Tests**, and **DOSAGE AND ADMINISTRATION** sections).

Patients with low platelet counts (<200,000/mm³) at the start of therapy are more likely to develop thrombocytopenia during treatment.

Thrombocytopenia is usually managed by reducing the dose or temporarily withholding JAKAVI. However, platelet transfusions may be required as clinically indicated (see **DOSAGE AND ADMINISTRATION**, and **ADVERSE DRUG REACTIONS** sections).

Patients developing anemia may require blood transfusions. Dose modifications or interruption for patients developing anemia may also be considered.

Neutropenia (Absolute Neutrophil Count (ANC) <500/mm³) is managed by temporarily withholding JAKAVI (see **DOSAGE AND ADMINISTRATION**, and **ADVERSE DRUG REACTIONS** sections).

Hemorrhage

Bleeding (in some cases fatal) have been reported in patients treated with JAKAVI (see **ADVERSE DRUG REACTIONS** and **Post-Marketing Adverse Drug Reactions** sections). Platelet counts should be monitored.

Immune

Infections

Serious bacterial, mycobacterial, fungal, viral and other opportunistic infections including pneumonia (in some cases fatal) have been reported in patients treated with JAKAVI.

Patients should be carefully assessed for the risk of developing serious bacterial, mycobacterial, fungal or viral infections. JAKAVI therapy should not be started until active serious infections have resolved. Physicians should carefully observe patients receiving JAKAVI for signs and symptoms of infections and initiate appropriate treatment promptly (see **ADVERSE DRUG REACTIONS**, **Post-Marketing Adverse Drug Reactions** and **TOXICOLOGY** sections).

The risk of visual disorders, including loss of vision, secondary to an eye infection may be a consequence of ruxolitinib-related infections. Physicians should carefully monitor patients receiving JAKAVI for eye infections in order to reduce the misdiagnosis of eye infections and to ensure patients receive the appropriate treatment.

Hepatitis B

Hepatitis B viral load (HBV-DNA titre) increases, with and without associated elevations in alanine aminotransferase and aspartate aminotransferase, have been reported in patients with chronic HBV infections taking JAKAVI. The effect of JAKAVI on viral replication in patients with chronic HBV infection is unknown. Patients with chronic HBV infection should be treated and monitored according to clinical guidelines.

Tuberculosis

Tuberculosis, including fatal cases, has been reported in patients receiving JAKAVI for myelofibrosis. Before starting treatment, patients should be evaluated for active and inactive ('latent') tuberculosis (see **WARNINGS AND PRECAUTIONS**, **Monitoring and Laboratory tests**). JAKAVI therapy should not be administered to patients with tuberculosis infection.

Herpes Zoster

Physicians should educate patients about early signs and symptoms of herpes zoster, advising that treatment should be sought as early as possible.

Progressive Multifocal Leukoencephalopathy

Progressive Multifocal leukoencephalopathy (PML) has been reported with JAKAVI treatment. PML can cause severe disability and death. Relationship between the risk of PML and the JAKAVI treatment is not known. Physicians should be particularly alert to symptoms suggestive of PML that patients may not notice (e.g., cognitive, neurological or psychiatric symptoms or signs). Patients should be monitored for any of these new or worsening symptoms or signs, and if

such symptoms/signs occur, referral to a neurologist and appropriate diagnostic measures for PML should be considered. JAKAVI treatment should be withheld if PML is suspected and discontinued if PML is confirmed.

Special Populations

Renal impairment

The starting dose of JAKAVI should be reduced to approximately 50% of the recommended dose, rounding up to the nearest dosage strength for patients with moderate or severe renal impairment (see **DOSAGE AND ADMINISTRATION** and **ACTION AND CLINICAL PHARMACOLOGY, Special Populations** sections).

Patients with end-stage renal disease (ESRD) on hemodialysis require individualized dosing regimens. There are limited data to determine the best dosing options for these patients (see **DOSAGE AND ADMINISTRATION** and **ACTION AND CLINICAL PHARMACOLOGY, Special Populations** sections).

Further dose modifications should be based on the safety and efficacy of the drug (see **DOSAGE AND ADMINISTRATION** and **ACTION AND CLINICAL PHARMACOLOGY, Special Populations** sections).

Hepatic impairment

The starting dose of JAKAVI should be reduced to approximately 50% of the recommended dose, rounding up to the nearest dosage strength in patients with any degree of hepatic impairment. Further dose modifications should be based on the safety and efficacy of the drug (see **DOSAGE AND ADMINISTRATION** and **ACTION AND CLINICAL PHARMACOLOGY, Special Populations** sections).

Pregnant Women

There are no adequate and well-controlled studies of JAKAVI in pregnant women. Ruxolitinib was embryotoxic and fetotoxic in rats and rabbits (increases in post-implantation loss and reduced fetal weights) (see **TOXICOLOGY** section).

The potential risk of teratogenicity for humans is unknown. The use of JAKAVI during pregnancy should be avoided.

Nursing Women

Women taking JAKAVI should not breast-feed.

In lactating rats, ruxolitinib and/or its metabolites were excreted into the milk with a concentration that was 13-fold higher than the maternal plasma concentration. It is not known whether JAKAVI is excreted in human milk.

Women of childbearing potential

Women of child-bearing potential must take appropriate precautions to avoid becoming pregnant during treatment.

In case pregnancy occurs, risk/benefit evaluations must be carried out on an individual basis with careful counseling regarding potential risk to the fetus using the most recent data available.

Males

It is not known if ruxolitinib or its metabolites are present in semen. Male patients must take appropriate precautions to avoid fathering a child during JAKAVI treatment.

Fertility

There are no data on the effect of ruxolitinib on human fertility (see **TOXICOLOGY** section).

Sensitivity/Intolerance

JAKAVI contains lactose. Patients with rare hereditary problems of galactose intolerance, severe lactase deficiency or glucose-galactose malabsorption should not take this medicinal product.

Geriatrics (> 65 years of age)

No additional dose adjustments are recommended for elderly patients.

Pediatrics (< 18 years of age)

Safety and efficacy of JAKAVI in pediatric patients have not been established.

Monitoring and Laboratory Tests

Blood cell counts: a blood cell count must be performed before initiating therapy with JAKAVI.

Complete blood counts should be monitored every 2-4 weeks until doses are stabilized, and then as clinically indicated (see **DOSAGE AND ADMINISTRATION** section).

Lipid monitoring: Lipid monitoring should be performed before initiating therapy with JAKAVI, then 4 weeks after starting therapy and regularly thereafter.

Liver and renal function tests: Liver and renal function tests should be performed prior to starting treatment with JAKAVI and periodically thereafter (see **DOSAGE AND ADMINISTRATION** section).

Cardiac Safety Monitoring: Patients receiving JAKAVI should be monitored for pulse rate and blood pressure. ECG evaluations should be performed at baseline and periodically during treatment with JAKAVI to monitor for decreased heart rate and PR interval prolongation (see **WARNINGS AND PRECAUTIONS**, Cardiovascular; **ADVERSE REACTIONS**, Electrocardiography; **DRUG INTERACTIONS** sections).

Tuberculosis test: A tuberculosis skin test and/or Interferon-gamma release assay should be performed before initiating therapy with JAKAVI to detect tuberculosis infection. However, these tests must be interpreted with caution in severely ill or immunocompromised patients given the possibility of a false negative result.

ADVERSE REACTIONS

Adverse Drug Reaction Overview

Patients with myelofibrosis:

For the primary safety analysis in patients with myelofibrosis, the median duration of exposure to JAKAVI was 10.8 months. The most frequently reported hematological adverse reactions (any CTCAE Grade; Common Terminology Criteria for Adverse Events, N=301 patients from ruxolitinib arms of COMFORT-I and COMFORT-II) included anemia (82.4%), thrombocytopenia (69.8%) and neutropenia (15.6%). Anemia, thrombocytopenia and neutropenia are dose related effects.

The three most frequent non-hematological adverse reactions were bruising (21.3%), dizziness (15.0%) and headache (13.6%).

The three most frequent non-hematological laboratory abnormalities were raised alanine aminotransferase (26.9%), raised aspartate aminotransferase (19.3%) and hypercholesterolemia (16.6%).

In Phase III MF clinical studies, discontinuation due to adverse events, regardless of causality was observed in 10.0% of the JAKAVI-treated patients. The most common reason for discontinuation was thrombocytopenia in 0.7% of JAKAVI-treated patients. In the two phase III studies, 41.2% of the JAKAVI -treated patients had a dose reduction for thrombocytopenia.

In the randomized, placebo controlled study (COMFORT-I), 60.6% of JAKAVI-treated patients and 37.7% of patients receiving placebo received red blood cell transfusions during randomized treatment. In the COMFORT-II study, the rate of packed red blood cell transfusions was 53.4% in the JAKAVI arm and 41.1% in the best available therapy arm (BAT).

Long term safety data based on the 5 years follow-up from two pivotal phase III studies assessing 457 patients with myelofibrosis treated with JAKAVI during the randomized and extension periods included data from patients that were initially randomized to JAKAVI (n=301, duration of exposure: 0.3 to 68.1 months, median duration of exposure = 33 months) and patients that received JAKAVI after crossing over from control treatment arms (n=156, duration of exposure: 0.5 to 59.8 months, median duration of exposure = 25.0 months). The cumulative frequency of some adverse events was increased approximately proportionally to the increase in the follow-up time.

At the 5 year cut off, the most frequent hematological adverse reactions for patients randomized to and crossed-over to JAKAVI were anemia (all Grades 83.8%, \geq Grade 3 48.6%), thrombocytopenia (all Grades 80.5%, \geq Grade 3 22.5%) and neutropenia (all Grades 20.8%, \geq Grade 3 9.8%).

The most frequent non-hematological adverse reactions, reported in the 5 years follow-up for patients randomized to and crossed-over to JAKAVI, were bruising (all Grades 33.3%, \geq Grade 3 0.7%), Other bleeding events (all Grades 24.5%, \geq Grade 3 4.2%), urinary tract infection (all Grades 21.2%, \geq Grade 3 3.7%).

Overall, including the 5 years follow-up of the Phase III studies, discontinuation due to adverse events, regardless of causality was observed in 30.0% of the patients randomized to or crossed over to JAKAVI, the most frequently reported adverse events (preferred terms [PTs]) leading to study drug discontinuation were thrombocytopenia (2.6%); acute myeloid leukemia (2.0%) and anemia (1.5%).

Based on the 5 years follow-up, cumulatively, 17.5% patients died during treatment or within 28 days of treatment discontinuation. The most frequently reported causes of death by system organ class (SOC) included infections and infestations (4.8%), general disorders and administration site conditions (3.1%) patients, and cardiac disorders (2.2%).

Patients with polycythemia vera:

For the primary safety analysis in patients with polycythemia vera at week 32 for RESPONSE, the most frequently reported hematological adverse reactions (any CTCAE Grade, N=110 patients from JAKAVI arm of RESPONSE) included anemia (43.6%) and thrombocytopenia (24.5%).

The four most frequent non-hematologic adverse reactions reported at a higher frequency in the JAKAVI group than in the BAT group were diarrhea (14.5%), muscle spasm (11.8%), dizziness (11.8%) and dyspnea (10.0%) respectively.

The most frequent non-hematological laboratory abnormalities (any CTCAE Grade) in the JAKAVI group were hypercholesterolemia (30.0%), gamma glutamyl transferase (Hyper) (29.1%), bicarbonate (Hypo) (28.2%), lipase (Hyper) (28.2%), raised alanine aminotransferase (22.7%), glucose (Hypo) (22.7%), and raised aspartate aminotransferase (20.9%) respectively.

Discontinuation for adverse events, regardless of causality, was observed in 3.6% of patients treated with JAKAVI and 1.8% of patients treated with best available therapy. The most frequent adverse events leading to dose adjustment in the JAKAVI group were anemia and thrombocytopenia.

The long term safety of JAKAVI was assessed in 184 patients with polycythemia vera in two open-label, randomized, controlled studies, the phase 3 RESPONSE study and the phase 3b RESPONSE 2 study. The adverse drug reactions listed below reflect the randomized study period (up to Week 32 for RESPONSE and up to Week 28 for RESPONSE 2) with equivalent exposure to ruxolitinib and Best Available Therapy. The median duration of exposure to JAKAVI during the randomized study periods was 7.85 months (range 0.03 to 7.85 months).

Discontinuation for adverse events, regardless of causality, was observed in 2.2% of patients.

Hematological adverse reactions (any CTCAE grade) included anemia (40.8%) and thrombocytopenia (16.8%). Anemia or thrombocytopenia Grade 3 and 4 were reported in respectively 1.1% or 3.3%.

The three most frequent non-hematological adverse reactions were dizziness (9.2%), constipation (8.7%), and hypertension (6.5%).

The three most frequent non-hematological laboratory abnormalities (any CTCAE grade) identified as adverse reactions were raised aspartate aminotransferase (26.1%), raised alanine aminotransferase (22.3%) and hypercholesterolaemia (20.7%). These were all Grade 1 to 2 with the exception of one Grade 3 raised alanine aminotransferase event.

Clinical Trial Adverse Drug Reactions

Because clinical trials are conducted under very specific conditions the adverse reaction rates observed in the clinical trials may not reflect the rates observed in practice and should not be compared to the rates in the clinical trials of another drug. Adverse drug reaction information from clinical trials is useful for identifying drug-related adverse events and for approximating rates.

Patients with Myelofibrosis:

At the time of the original marketing authorization application, JAKAVI has been administered to 617 patients with different disease settings. The safety profile of JAKAVI in patients with myelofibrosis was derived from 589 patients treated in two pivotal phase III studies and one phase II supporting study. In the clinical studies program, the severity of adverse drug reactions was assessed based on the Common Terminology Criteria for Adverse Events (CTCAE) version 3.0 defining Grade 1=mild, Grade 2=moderate, Grade 3=severe and Grade 4=life-threatening or disabling.

At the time of the primary analysis for the randomized period of the two pivotal studies COMFORT-I and COMFORT-II, 301 patients had a median duration of exposure to JAKAVI of 10.8 months (range 2 weeks to 19.5 months). The majority of patients (68.4%) were treated for at least 9 months. Of the 301 patients, 111 (36.9%) had a baseline platelet count between 100,000/mm³ and 200,000/mm³, and 190 (63.1%) had a baseline platelet count >200,000/mm³.

COMFORT-I was a randomized, double-blind, placebo-controlled phase III study in patients with Primary Myelofibrosis (MF), Post-Polycythemia Vera Myelofibrosis (PPV-MF) or Post-Essential Thrombocythemia-Myelofibrosis (PET-MF). Three hundred and nine (309) patients were randomized to this study. Patients were randomized to receive JAKAVI (155 patients) or matching placebo tablets (151 patients).

COMFORT-II was a randomized, open-label, efficacy and safety phase III study of JAKAVI tablets compared to best available therapy (BAT) in patients with PMF, PPV-MF or PET-MF. Two hundred and nineteen (219) patients were randomized to this study. Patients were stratified at baseline by prognostic risk category and randomized 2:1 to receive either JAKAVI (146 patients) or BAT (73 patients).

Tabulated summary of adverse drug reactions from clinical trials

Adverse drug reactions (ADRs) from clinical trials (Tables 1) are listed by MedDRA system organ class. Within each system organ class, the adverse drug reactions are ranked by frequency, with the most frequent reactions first.

Table 1 Percentage of MF patients with adverse drug reactions $\geq 1\%$ in clinical studies

System Organ Class/MedDRA Preferred term ¹	COMFORT-I				COMFORT-II			
	JAKAVI N=155		Placebo N=151		JAKAVI N=146		Best available therapy N=73	
	% All Grades	% \geq Grade 3	% All Grades	% \geq Grade 3	% All Grades	% \geq Grade 3	% All Grades	% \geq Grade 3
Any ADR	64.5	6.5	38.4	5.3	56.8	11.0	32.9	5.6
Blood and lymphatic system disorders								
Any bleeding ²	37.4	5.2	25.8	3.3	27.4	4.8	17.8	2.7
Bruising ³	27.1	0.6	14.6	0	15.1	0	5.5	0
Other bleeding ⁴	12.9	2.6	8.6	0.7	13.7	2.1	13.7	2.7
Gastrointestinal bleeding ⁵	3.9	1.3	4.0	2.0	6.2	1.4	1.4	0
Intracranial bleeding ⁶	0.6	0.6	1.3	1.3	1.4	1.4	0	0
Cardiac disorders								
Angina pectoris/ unstable angina	0	0	0	0	4.1	0	1.4	0
Bradycardia/ sinus bradycardia	3.2	0	1.3	0	3.4	0	0	0
Palpitation	2.6	0	0.7	0	4.8	0	1.4	0
Gastrointestinal disorders								
Flatulence	5.2	0	1.3	0	1.4	0	0	0
General disorders and administration site conditions								
Pyrexia	12.3	0.6	7.9	0.7	15.1	2.1	9.6	0
Infections and infestations								
Pneumonia	11.0	6.5	7.9	6.0	5.5	2.1	9.6	5.5
Urinary Tract infections ⁷	9.7	0	5.3	1.3	15.1	2.1	6.8	0
Herpes zoster ⁸	1.9	0	1.3	0.7	6.8	0.7	0	0
Tuberculosis	0	0	0	0	0.7	0.7	0	0
Metabolism and nutrition disorders								
Weight gain ⁹	9.0	0.6	1.3	0.7	11.0	2.1	1.4	0.7
Nervous system disorders								

Dizziness ¹⁰	19.4	0.6	7.9	0	10.3	0	9.6	2.7
Headache	15.5	0	6.0	0	11.6	1.4	5.5	0

- A subject with multiple occurrences of an ADR is counted only once in that ADR category.

- ADRs were counted at the most severe Grade.

¹ The frequency of most preferred terms displayed in this table is based on a group of similar preferred terms. These are annotated to each term.

² This includes all Preferred Terms noted below under 3, 4, 5 and 6.

³ This includes the Preferred Terms of contusion, hematoma, ecchymosis, petechiae, increased tendency to bruise, periorbital hematoma, purpura, injection site hematoma and vessel puncture site hematoma.

⁴ This includes the Preferred Terms of epistaxis, haematuria, post procedural hemorrhage, retinal hemorrhage, conjunctival hemorrhage, hemoptysis, disseminated intravascular coagulation, genital hemorrhage, hemorrhage, hemorrhagic anemia, intrabdominal hemorrhage, mouth hemorrhage, muscle hemorrhage, retroperitoneal hematoma, retroperitoneal hemorrhage, splenic hemorrhage, blood urine present, gingival bleeding, intra-abdominal haematoma, peritoneal hemorrhage, splenic haematoma.

⁵ This includes the Preferred Terms of gastrointestinal hemorrhage, melaena, hemorrhoidal hemorrhage, rectal hemorrhage, hematochezia, oesophageal varices hemorrhage, upper gastrointestinal hemorrhage and gastric varices hemorrhage.

⁶ This includes the Preferred Terms of cerebral hemorrhage and subdural hematoma.

⁷ This includes the Preferred Terms of urinary tract infection, cystitis, urosepsis, urinary tract infection bacterial, pyuria, bacteria urine, kidney infection, bacteria urine identified and nitrite urine present.

⁸ This includes the Preferred Terms of herpes zoster, postherpetic neuralgia, herpes virus infection and trigeminal neuralgia.

⁹ This includes the Preferred Terms of weight increased and abnormal weight gain.

¹⁰ This includes the Preferred Terms of dizziness, vertigo, balance disorder, dizziness postural and Meniere's. In addition a Grade 1 labyrinthitis was observed in 1 patient in Study 352 (JAKAVI arm).

Upon discontinuation, some patients have experienced a rapid return of MF symptoms such as fatigue, bone pain, fever, pruritus, night sweats, symptomatic splenomegaly and weight loss. In clinical studies the total symptom score for MF symptoms gradually returned to baseline values within 7 days after dose discontinuation.

Description of selected adverse drug reactions

Infections

In phase III MF clinical studies, Grade 3 or 4 urinary tract infection was reported for 1.0% of patients, herpes zoster (any Grade) in 4.3% and tuberculosis (any Grade) in 1.0%. In addition, urosepsis was reported in 1.0% of patients and kidney infection was reported in 1 patient.

Bleeding

In the phase III pivotal MF studies, bleeding events (including intracranial and gastrointestinal, bruising and other bleeding events) were reported in 32.6% of patients exposed to JAKAVI and 23.2% of patients exposed to the reference treatments (placebo or best available therapy). The frequency of Grade 3 or 4 events was similar for patients treated with JAKAVI or reference treatments (4.7% versus 3.1%). Most of the patients with bleeding events during the treatment reported bruising (65.3%). Bruising events were more frequently reported in patients taking JAKAVI compared with the reference treatments (21.3% versus 11.6%). Intracranial bleeding was reported in 1% of patients exposed to JAKAVI and 0.9% exposed to reference treatments. Gastrointestinal bleeding was reported in 5.0% of patients exposed to JAKAVI compared to 3.1% exposed to reference treatments. Other bleeding events (including events such as epistaxis, post procedural hemorrhage and haematuria) were reported in 13.3% of patients treated with JAKAVI and 10.3% treated with reference treatments.

Increased systolic blood pressure

In the phase III pivotal clinical MF studies, an increase in systolic blood pressure of 20 mmHg or more from baseline was recorded in 31.5% of patients on at least one visit compared with 19.5% of the control treated patients. In COMFORT I, the mean increase from baseline in systolic BP was 0-2 mmHg in the JAKAVI arm versus a decrease of 2-5 mmHg in the placebo arm. In COMFORT II, mean values showed little difference between the JAKAVI treated and the control treated patients.

Electrocardiography

In the phase III MF clinical trials, steady-state treatment with JAKAVI was associated with statistically significant decreases from baseline in heart rate and statistically significant increases from baseline in the PR interval (see **WARNINGS AND PRECAUTIONS**, Cardiovascular & Monitoring and Laboratory Tests, **DRUG INTERACTIONS** sections). In the placebo-controlled trial, the placebo-adjusted mean changes from baseline in these parameters were statistically significant and ranged from -6 to -8 bpm for heart rate and 6 to 9 ms for the PR interval from weeks 4-24. Among subjects with normal PR values at baseline, the proportion who developed PR values >200 ms during treatment was 12.3% for JAKAVI, 4.9% for placebo, and 4.7% for best available therapy.

Statistically significant QTc prolongation was not observed in the placebo-controlled phase III trial. In the phase III trial versus best available therapy, statistically significant QTc increases from baseline of mean 4-5 ms were observed at weeks 4 and 24.

Abnormal Hematologic and Clinical Chemistry Findings

Table 2 Hematology (laboratory data) in MF patients

Laboratory parameter	COMFORT-I				COMFORT-II			
	JAKAVI N=155		Placebo N=151		JAKAVI N=146		Best available therapy N=73	
	% All Grades	% ≥ Grade 3	% All Grades	% ≥ Grade 3	% All Grades	% ≥ Grade 3	% All Grades	% ≥ Grade 3
Anemia	83.2	44.5	43.7	15.9	81.5	40.4	49.3	20.5
Thrombocytopenia	71.0	13.5	21.2	2.0	68.5	8.9	28.8	6.8
Neutropenia	18.7	7.1	4.0	3.3	12.3	6.2	8.2	1.4

Table 3 Biochemistry (laboratory data) in MF patients

Laboratory parameter	COMFORT-I				COMFORT-II			
	JAKAVI N=155		Placebo N=151		JAKAVI N=146		Best available therapy N=73	
	%	%	%	%	%	%	%	%
	All Grades	≥ Grade 3	All Grades	≥ Grade 3	All Grades	≥ Grade 3	All Grades	≥ Grade 3
Hepatobiliary disorders								
Raised alanine aminotransferase ¹	28.4	1.3	8.6	0	25.3	1.4	6.8	0
Raised aspartate aminotransferase	18.7	0	6.6	0	19.9	0	4.1	0
Metabolism and nutrition disorders								
Hypercholesterolemia	17.4	0	0.7	0	15.8	0	6.8	0
¹ In phase III clinical studies no CTCAE Grade 4 raised alanine aminotransferase was observed.								

Anemia

In phase III MF clinical studies, median time to onset of first CTCAE Grade 2 or higher anemia was 1.5 months. One patient (0.3%) discontinued treatment because of anemia.

In patients receiving JAKAVI, mean decreases in hemoglobin level reached a nadir of approximately 1.5 to 2.0 g/dL below baseline after 8 to 12 weeks of therapy and then gradually improved to reach a new steady state that was approximately 1.0 g/dL below baseline. This pattern was observed in patients regardless of whether they had received transfusion during therapy. Female MF patients may be at higher risk of anemia than male MF patients.

Thrombocytopenia

In the Phase III MF clinical studies, in patients who developed Grade 3 or 4 thrombocytopenia, the median time to onset was approximately 8 weeks. Thrombocytopenia was generally reversible with dose reduction or dose interruption. The median time to recovery of platelet counts above 50,000/mm³ was 14 days. During the randomized period, platelet transfusions were administered to 4.7% of patients receiving JAKAVI and to 4.0% of patients receiving control regimens.

Discontinuation of treatment because of thrombocytopenia occurred in 0.7% of patients receiving JAKAVI and 0.9% of patients receiving control regimens. Patients with a platelet count of 100,000/mm³ to 200,000/mm³ before starting JAKAVI had a higher frequency of thrombocytopenia compared to patients with platelet count >200,000/mm³ (64.2% versus 35.4%).

Neutropenia

In the phase III MF clinical studies, in patients who developed Grade 3 or 4 neutropenia, the median time of onset was 12 weeks. During the randomized period of the studies, dose holding

or reductions due to neutropenia were reported in 1.3% of patients and 0.3% of patients discontinued treatment because of neutropenia.

Patients with polycythemia vera:

At the time of the primary analysis the safety of JAKAVI was assessed in 240 patients with polycythemia vera treated with JAKAVI during a pivotal phase III study (n=206) and a supporting phase II study (n=34). The phase III study (RESPONSE study) was an open-label, randomized, controlled study. Patients were randomized to receive either 10 mg JAKAVI twice a day or Best Available Therapy (BAT). During the randomized period, 110 patients received JAKAVI and 111 patients received BAT. After 32 weeks of treatment, 96 patients from the BAT arm crossed-over to receive JAKAVI, which created an imbalance in drug exposure between the two arms. Consequently, the adverse drug reactions listed below are derived from the randomized study period (up to the week 32 visit) during which the exposures to JAKAVI and BAT were equivalent (median duration of exposure = 7.8 months in both arms). The mean age of patients was around 60 years.

Among patients randomized to JAKAVI, the median duration of exposure was 18.6 months (for the period up the cut-off date for the primary analysis of the pivotal study). An analysis of safety including data from the cross-over study period (median exposure 11.4 months) and a supportive phase II study (median exposure 48.1 months) was also performed. The cumulative frequency of AEs in JAKAVI-treated patients increased but no new safety findings emerged. When adjusted for exposure, the AE rates were generally comparable with those observed during the randomized study period.

Long term safety was evaluated using data from 367 patients with polycythemia vera treated with JAKAVI in two phase 3 studies (RESPONSE and RESPONSE 2) including data from patients initially randomized to JAKAVI (n=184; exposure 0.03 to 43.5 months, median exposure 18.9 months) and patients who received JAKAVI after crossing over from control treatments (n=149; exposure: 0.2 to 33.5 months, median exposure 12.0 months): With longer exposure, the cumulative frequency of AEs increased but no new safety findings emerged.

Tabulated summary of Adverse drug reactions from clinical trial

Table 4 Adverse drug reactions (≥3%) reported at a higher frequency (>1%) in the JAKAVI group than in the BAT group up to Week 32- in the RESPONSE study

System Organ Class/MedDRA Preferred Term	JAKAVI N=110		Best available therapy N=111	
	%	%	%	%
	All Grades	≥ Grade 3	All Grades	≥ Grade 3
Ear and labyrinth disorders				
Tinnitus	6 (5.5)	2 (1.8)	3 (2.7)	0 (0.0)

Gastrointestinal disorders				
Diarrhea	16 (14.5)	0 (0.0)	8 (7.2)	1 (0.9)
Constipation	9 (8.2)	0 (0.0)	3 (2.7)	0 (0.0)
Nausea	7 (6.4)	0 (0.0)	4 (3.6)	0 (0.0)
Infections and infestations				
Herpes zoster	7 (6.4)	0 (0.0)	0 (0.0)	0 (0.0)
Urinary tract infection	5 (4.5)	1 (0.9)	0 (0.0)	0 (0.0)
Investigations				
Weight increased	6 (5.5)	0 (0.0)	1 (0.9)	0 (0.0)
Musculoskeletal and connective tissue disorders				
Muscle spasms	13 (11.8)	1 (0.9)	5 (4.5)	0 (0.0)
Back pain	6 (5.5)	1 (0.9)	4 (3.6)	0 (0.0)
Nervous system disorders				
Dizziness	13 (11.8)	0 (0.0)	11 (9.9)	0 (0.0)
Hypoaesthesia	4 (3.6)	0 (0.0)	1 (0.9)	0 (0.0)
Psychiatric disorders				
Anxiety	4 (3.6)	0 (0.0)	1 (0.9)	0 (0.0)
Respiratory, thoracic and mediastinal disorders				
Dyspnea	11 (10.0)	3 (2.7)	2 (1.8)	0 (0.0)
Cough	9 (8.2)	0 (0.0)	6 (5.4)	0 (0.0)
Epistaxis	7 (6.4)	0 (0.0)	3 (2.7)	0 (0.0)
Oropharyngeal pain	4 (3.6)	0 (0.0)	1 (0.9)	0 (0.0)
Vascular disorders				
Haematoma	6 (5.5)	0 (0.0)	3 (2.7)	0 (0.0)
Hypertension	5 (4.5)	1 (0.9)	3 (2.7)	1 (0.9)
- A subject with multiple occurrences of an ADR is counted only once in that ADR category.				
- ADRs were counted at the most severe Grade				

Table 5 Adverse drug reactions in patients with PV who received JAKAVI group or BAT group up to Week 28 in RESPONSE 2 study

Adverse drug reactions and CTCAE grade	RESPONSE 2	
	Ruxolitinib N=74	BAT N=75
	%	%
Infections and infestations		
Urinary tract infections ¹	6.8	0
Herpes zoster ¹	1.4	0
Blood and lymphatic system disorders		
Anemia ²		
CTCAE ³ grade 4 (<6.5g/dL)	0	0
CTCAE grade 3 (<8.0–6.5g/dL)	0	0
Any CTCAE grade	36.5	21.3
Thrombocytopenia ²		
CTCAE grade 4 (<25,000/mm ³)	0	1.3
CTCAE grade 3 (50,000 – 25,000/mm ³)	0	1.3
Any CTCAE grade	5.4	25.3
Metabolism and nutrition disorders		
Weight gain ¹	9.5	1.3
Hypercholesterolemia ² Any CTCAE grade	6.8	0
Hypertriglyceridemia ² Any CTCAE grade	9.5	1.3
Nervous system disorders		
Dizziness ¹	6.8	8.0
Gastrointestinal disorders		
Constipation ¹	9.5	5.3
Hepatobiliary disorders		
Raised alanine aminotransferase ²		
CTCAE grade 3 (> 5x – 20 x ULN)	0	0
Any CTCAE grade	21.6	6.7

Raised aspartate aminotransferase ²		
Any CTCAE grade	33.8	16.0
Vascular disorders		
Hypertension ¹	9.5	4.0
¹ Frequency is based on adverse event data. ² Frequency is based on laboratory values. -A subject with multiple occurrences of an ADR is counted only once in that ADR category. -ADRs reported are on treatment or up to 28 days post treatment end date. ³ Common Terminology Criteria for Adverse Events (CTCAE) Version 3.0; Grade 1=mild, Grade 2= moderate, Grade 3=severe, grade 4=life-threatening or disabling		

Description of selected adverse drug reactions

Infections

Over the randomized period in the pivotal Phase III study, one (0.9%) Grade 3-4 urinary tract infection was observed in PV patients. The rate of herpes zoster was higher in the JAKAVI arm (6.4%) than in BAT arm (0.0%). There was one report of Grade 3 and 4 post herpetic neuralgia amongst the PV patients.

At the most recent cut off, over the randomized period in the RESPONSE (32 weeks) and RESPONSE-2 (28 weeks) studies in PV, one (0.5%) Grade 3 to 4 urinary tract infection was observed. The rate of herpes zoster was reported in PV (4.3%) patients. There was one report of Grade 3 and 4 post herpetic neuralgia amongst the PV patients.

Electrocardiography

In the pivotal phase III PV study, at week 32, the mean change from baseline in heart rate was -5.84 vs +1.94 beat/min, in JAKAVI vs BAT arm respectively. Notably abnormal vital signs were comparable (< 5% difference) in both arms, except for low heart rate that was reported in 7.3% vs 1.8% of patients in JAKAVI vs BAT arm, respectively.

Abnormal Hematologic and Clinical Chemistry Findings

Table 6 Hematology (laboratory data) $\geq 2\%$ in PV patients (up to week 32 in the RESPONSE Study)

Laboratory parameter	JAKAVI N=110		BAT N=111	
	%	%	%	%
	All Grades	\geq Grade 3	All Grades	\geq Grade 3
Anemia	43.6	1.8	30.6	0
Thrombocytopenia	24.5	5.4	18.9	3.6

Table 7 New or worsened biochemistry abnormalities in PV patients (at least 20% in all Grades of JAKAVI) up to week 32 by treatment group

	JAKAVI N=110		BAT N=111	
	All Grades (%)	≥Grade 3 (%)	All Grades (%)	≥Grade 3 (%)
Cholesterol (Hyper)	30.0	0	6.3	0
Gamma Glutamyl Transferase (Hyper)	29.1	3.6	21.6	3.6
Bicarbonate (Hypo)	28.2	0	30.6	0
Lipase (Hyper)	28.2	4.5	17.1	2.7
Alanine Aminotransferase (Hyper)	22.7	0.9	10.8	0
Glucose (Hypo)	22.7	0	22.5	0
Aspartate Aminotransferase (Hyper)	20.9	0	17.1	0.9

Anemia

Over the randomized period in the pivotal study (RESPONSE Trial), anemia was more frequent in the JAKAVI arm (43.6%) compared to the BAT arm (30.6%). The CTCAE Grade 3 and 4 events were reported in 1.8% of the patients in the JAKAVI arm and in 0% of the patients in the BAT arm. Female PV patients may be at higher risk of anemia than male PV patients.

At the most recent cut off, over the randomized period in the RESPONSE (32 weeks) and RESPONSE 2 (28 weeks) studies, anemia was reported in PV patients (40.8%). The frequency of the CTCAE Grade 3 and 4 events was 1.1% in PV patients.

Thrombocytopenia

Over the randomized period in the pivotal study, the rate of patients experiencing thrombocytopenia was higher in the JAKAVI arm (24.5%) compared to the BAT arm (18.9%). The frequency of severe (i.e. of CTCAE Grade 3 and 4) thrombocytopenia was 5.4% in the JAKAVI arm and 3.6% in the BAT arm.

At the most recent cut off, over the randomized period in the RESPONSE (32 weeks) and RESPONSE 2 (28 weeks) studies, the rate of patients experiencing thrombocytopenia was 16.8%. The frequency of severe (i.e. of CTCAE Grade 3 and 4) thrombocytopenia was reported in 3.3% patients.

Neutropenia

Over the randomized period in the pivotal study, in PV patients, neutropenia was observed in 2 patients in the JAKAVI arm (1.8%) of which one patient developed CTCAE Grade 4 neutropenia.

At the most recent cut off, over the randomized period in the RESPONSE (32 weeks) and

RESPONSE 2 (28 weeks) studies in PV, neutropenia was observed in 3 patients (1.6%) of which one patient developed CTCAE Grade 4 neutropenia.

Post-Marketing Adverse Drug Reactions

The following adverse reactions have been derived from spontaneous case reports, literature cases and clinical studies. The criteria for including these adverse reactions are based on the seriousness. Because these reactions are reported voluntarily from a population of uncertain size, it is not always possible to reliably estimate their frequency or establish a causal relationship to drug exposure.

Infections and Infestations:

Tuberculosis (including fatal tuberculosis and fatal miliary tuberculosis), progressive multifocal leukoencephalopathy (PML), pneumonia (including fatal pneumonia), sepsis (including fatal sepsis) and endocarditis (including fatal endocarditis), opportunistic fungal infections (including fatal cases) and viral reactivation.

Bleeding:

Cerebral hemorrhage (including fatal case), gastrointestinal bleeding (including fatal cases).

DRUG INTERACTIONS

Drug-Drug Interactions

Agents that may alter plasma concentration of ruxolitinib

Strong CYP3A4 inhibitors: in healthy subjects receiving ketoconazole, a strong CYP3A4 inhibitor, at 200 mg twice daily for four days, the AUC of ruxolitinib increased by 91% and the half-life was prolonged from 3.7 to 6.0 hours.

When administering JAKAVI with strong CYP3A4 inhibitors, the total daily dose of JAKAVI should be reduced to approximately 50% of the dose rounding up to the nearest dosage strength.

Patients should be closely monitored for cytopenias and the dose should be titrated based on safety and efficacy (see **DOSAGE AND ADMINISTRATION** section).

Mild or moderate CYP3A4 inhibitors: in healthy subjects receiving erythromycin, a moderate CYP3A4 inhibitor, at 500 mg twice daily for four days, there was a 27% increase in the AUC of JAKAVI.

No dose adjustment is recommended when JAKAVI is co administered with mild or moderate CYP3A4 inhibitors (e.g. erythromycin). Patients should be closely monitored for cytopenias when initiating therapy with a moderate CYP3A4 inhibitor.

Concomitant moderate CYP2C9 and CYP3A4 inhibitors (including a dual enzyme inhibitor as a single agent, e.g. Fluconazole): Based on *in silico* modeling, an AUC increase of ruxolitinib of

102%, 190% or 330% is predicted when co-administered with 100 mg, 200 mg or 400 mg fluconazole, respectively. A 50% dose reduction should be considered when concomitantly administering medicinal products which are moderate inhibitors of CYP2C9 and CYP3A4. Avoid the concomitant use of JAKAVI with fluconazole doses of greater than 200 mg daily.

Effect of ruxolitinib on other agents

Hematopoietic growth factors: The concurrent use of haematopoietic growth factors and JAKAVI has not been studied. It is not known whether the Janus Associated Kinase (JAK) inhibition by JAKAVI reduces the efficacy of the haematopoietic growth factors or whether the haematopoietic growth factors affect the efficacy of JAKAVI.

Cytoreductive therapies: The concomitant use of cytoreductive therapies and JAKAVI has not been studied. The safety and efficacy of this co-administration is not known.

Drugs that Decrease Heart Rate and/or Prolong the PR Interval: JAKAVI results in a decrease in heart rate and an increase in the PR interval (see **WARNINGS AND PRECAUTIONS**, Cardiovascular & Monitoring and Laboratory Tests; **ADVERSE REACTIONS**, Electrocardiography sections). The concomitant use of JAKAVI with other drugs that lower heart rate and/or prolong the PR interval, such as antiarrhythmics, beta blockers, non-dihydropyridine calcium channel blockers, digitalis glycosides, cholinesterase inhibitors, sphingosine-1 phosphate receptor modulators, and HIV protease inhibitors should be avoided to the extent possible.

Drug-Laboratory Interactions

Interactions with laboratory tests have not been established.

Drug-Lifestyle Interactions

There are no physical restrictions for patients who receive JAKAVI.

DOSAGE AND ADMINISTRATION

Dosing Considerations

The following safety issues should be considered when developing a dosage regimen in an individual patient:

- Platelet count,
- Absolute neutrophil count,
- Renal impairment,
- Hepatic impairment,
- Concomitant strong CYP3A4 inhibitors,
- Concomitant moderate CYP3A4 and CYP2C9 inhibitors.
- Doses may be titrated based on safety and efficacy.

Recommended Dose and Dosage Adjustment

The recommended starting dose of JAKAVI is based on platelet count and on the indication to be treated (Table 8). A complete blood count and platelet count must be performed before initiating therapy, every 2 to 4 weeks until doses are stabilized, and then as clinically indicated.

Table 8 JAKAVI Starting Doses for patients with myelofibrosis or with polycythemia vera.

Platelet Count	Starting Dose	
	Myelofibrosis	Polycythemia vera
Greater than 200,000/ mm ³	20 mg orally twice daily	10 mg orally twice daily
100,000 to 200,000/ mm ³	15 mg orally twice daily	10 mg orally twice daily
50,000 to <100,000/mm ^{3*}	5 mg orally twice daily	5 mg orally twice daily

* There is limited information to recommend a starting dose for patients with platelet counts between 50,000/mm³ and <100,000/mm³. The dose of these patients should be titrated cautiously.

Prior to initiating treatment with JAKAVI, the Absolute Neutrophil Count (ANC) of patients should be >1000/mm³.

Dose modifications based on safety:

Treatment interruptions: Treatment with JAKAVI should be interrupted for :

- platelet counts less than 50,000/mm³
- absolute neutrophil counts less than 500/mm³.
- hemoglobin less than 8g/dl (only for PV patients).

After recovery of blood counts above these levels, dosing may be restarted at 5 mg twice daily and gradually increased based on careful monitoring of blood cell counts.

Interrupt treatment for bleeding requiring intervention regardless of current platelet count. Once the bleeding event has resolved, consider resuming treatment at the prior dose if the underlying cause of bleeding has been controlled. If the bleeding event has resolved but the underlying cause persists, consider resuming treatment with JAKAVI at a lower dose.

Dose reductions: Dose reductions should be considered if the platelet counts decrease as outlined in Table 9 below, with the goal of avoiding dose interruptions for thrombocytopenia.

Table 9 Dosing Recommendations for Thrombocytopenia

Platelet Count	Dose at Time of Platelet Decline				
	25 mg twice daily	20 mg twice daily	15 mg twice daily	10 mg twice daily	5 mg twice daily
	New Dose	New Dose	New Dose	New Dose	New Dose
100,000 to less than 125,000/ mm ³	20 mg twice daily	15 mg twice daily	No Change	No Change	No Change
75,000 to less than 100,000/ mm ³	10 mg twice daily	10 mg twice daily	10 mg twice daily	No Change	No Change
50,000 to less than 75,000/ mm ³	5 mg twice daily	5 mg twice daily	5 mg twice daily	5 mg twice daily	No Change
Less than 50,000/ mm ³	Hold	Hold	Hold	Hold	Hold

For PV patients, dose reduction should also be considered if hemoglobin decreases below 12g/dL and is recommended if hemoglobin decreases below 10g/dL.

Dose modifications based on efficacy:

If efficacy is considered insufficient, doses may be increased by a maximum of 5 mg twice daily. The maximum dose of JAKAVI is 25 mg twice daily. The dose should not be increased if the blood counts are not adequate. The platelet counts should be greater than 125,000/mm³ at the time of dose increase and should never have been below 100,000 mm³. The ANC levels should be greater than 750/mm³.

The starting dose should not be increased within the first four weeks of treatment for patients with myelofibrosis and eight weeks of treatment for patients with polycythemia vera and thereafter no more frequently than at 2-week intervals.

Treatment may be continued as long as the benefit: risk balance remains positive. However, the treatment of patients with myelofibrosis should be discontinued after 6 months if there has been no reduction in spleen size or improvement in symptoms since initiation of therapy. In patients with polycythemia vera, the treatment should be discontinued after 16 months if there has been no clinical benefit since initiation of therapy.

Dose adjustment with concomitant use of strong CYP3A4 inhibitors or moderate CYP2C9 and CYP3A4 inhibitors (e.g. fluconazole):

When JAKAVI is administered with strong CYP3A4 inhibitors or concomitant administration of moderate inhibitors of CYP2C9 and CYP3A4 (including a dual enzyme inhibitor as a single agent, e.g. fluconazole), the dose of JAKAVI should be reduced to approximately 50% of the dose, rounding up to the nearest dosage strength. Avoid the concomitant use of JAKAVI with fluconazole doses of greater than 200 mg daily (see **DRUG INTERACTIONS** section).

More frequent monitoring (e.g. twice a week) of hematology parameters and of clinical signs and symptoms of JAKAVI related adverse reactions is recommended upon initiation of a strong

CYP3A4 inhibitor or moderate CYP2C9 and CYP3A4 inhibitors. If the platelet count decreases to less than 100,000/mm³, the concomitant use should be avoided when on JAKAVI treatment.

Dosing in special populations

Renal impairment

For patients with moderate (creatinine clearance, CrCl: 30-50mL/min) or severe (CrCl:<30mL/min) renal impairment, the starting dose should be approximately 50% of the recommended dose based on platelet count (table 7). The dose should be rounded up to the nearest dosage strength if necessary.

JAKAVI should be avoided in patients with moderate or severe renal impairment with platelet counts less than 100,000/mm³.

Patients diagnosed with moderate or severe renal impairment while receiving JAKAVI should be carefully monitored and may need to have their doses titrated to avoid adverse drug reactions.

There are limited data to determine the best dosing options for patients with end-stage renal disease (ESRD) on hemodialysis. Available data in this population suggest that the starting dose for myelofibrosis patients with ESRD on hemodialysis is 15 mg once a day for patients with platelet count between 100,000-200,000/mm³ or 20 mg once a day for patients with platelet count of >200,000/mm³. The recommended starting dose for polycythemia vera patients with ESRD on hemodialysis is 10 mg once a day. JAKAVI is to be administered after hemodialysis has been completed and only on the day of hemodialysis. JAKAVI should not be given more frequently than once a day. Dose modification should be made with careful monitoring of safety and efficacy of individual patients. No data is available for dosing patients who are undergoing peritoneal dialysis or continuous venous hemofiltration (see **ACTION AND CLINICAL PHARMACOLOGY** section).

Hepatic Impairment

In patients with mild, moderate or severe hepatic impairment, the starting dose should be approximately 50% of the recommended starting dose based on platelet count (table 7). The dose should be rounded up to the nearest dosage strength if necessary.

JAKAVI should be avoided in patients with hepatic impairment with platelet counts less than 100,000/mm³.

Patients diagnosed with hepatic impairment while receiving JAKAVI should be carefully monitored and may need to have their dose titrated to avoid adverse drug reactions.

Geriatrics (> 65 years of age):

No additional dose adjustments are recommended for elderly patients.

Missed Dose

If a dose is missed, the patient should not take an additional dose, but should take the next usual prescribed dose.

Administration

JAKAVI is dosed orally and can be administered with or without food. Patients should be instructed to swallow the tablet whole. The tablets should NOT be cut, broken, dissolved, crushed or chewed.

OVERDOSAGE

For management of a suspected drug overdose, contact your regional Poison Control Centre.

There is no known antidote for overdoses with JAKAVI. Single doses up to 200 mg have been given with acceptable acute tolerability. Higher than recommended repeat doses are associated with increased myelosuppression including leukopenia, anemia and thrombocytopenia. Appropriate supportive treatment should be given.

Hemodialysis is not expected to enhance the elimination of JAKAVI.

ACTION AND CLINICAL PHARMACOLOGY

Mechanism of Action

Ruxolitinib is a selective inhibitor of the Janus Kinases (JAKs) JAK1 (IC₅₀ 3.3 nM) and JAK2 (IC₅₀ 2.8 nM). These mediate the signaling of a number of cytokines and growth factors that are important for hematopoiesis and immune function. JAK signaling involves recruitment of STATs (signal transducers and activators of transcription) to cytokine receptors, activation, and subsequent localization of STATs to the nucleus leading to modulation of gene expression. Dysregulation of the JAK-STAT pathway has been associated with several cancers and increased proliferation and survival of malignant cells.

Myelofibrosis (MF) and Polycythemia vera (PV) are myeloproliferative neoplasms (MPN) known to be associated with dysregulated JAK1 and JAK2 signaling. The basis for the dysregulation is believed to include high levels of circulating cytokines that activate the JAK-STAT pathway, gain-of function mutations such as JAK2^{V617F}, and silencing of negative regulatory mechanisms. MF patients exhibit dysregulated JAK signaling regardless of JAK2^{V617F} mutation status. Activating mutations in JAK2 (such as JAK2^{V617F} or other exon 12 mutations) are found in >95% of PV patients.

Ruxolitinib inhibits JAK-STAT signaling and cell proliferation of cytokine-dependent cellular models of hematological malignancies, as well as of Ba/F3 cells rendered cytokine-independent by expressing the JAK2^{V617F} mutated protein, with IC₅₀'s ranging from 80-320 nM. In a mouse model of JAK2^{V617F}-positive MPN, oral administration of ruxolitinib prevented splenomegaly, preferentially decreased JAK2^{V617F} mutant cells in the spleen, decreased circulating inflammatory cytokines (eg, TNF-alpha, IL-6) and resulted in significantly prolonged survival in the mice at doses that did not cause myelosuppressive effects.

Pharmacodynamics

Ruxolitinib inhibits cytokine induced STAT3 phosphorylation in whole blood from healthy subjects as well as MF and PV patients. Ruxolitinib resulted in maximal inhibition of STAT3 phosphorylation 2 hours after dosing which returned to near baseline by 8 hours in both healthy subjects and myelofibrosis patients, indicating no accumulation of either parent or active metabolites.

In a double-blind, placebo-controlled, crossover ECG study in healthy subjects (N=49), there was no indication of a QTc prolonging effect of ruxolitinib at single doses of 25 mg and 200 mg.

Pharmacokinetics

Absorption: Ruxolitinib is a Class 1 molecule under the Biopharmaceutical Classification System, with high permeability, high solubility and rapid dissolution characteristics. In clinical studies, ruxolitinib is rapidly absorbed after oral administration with maximal plasma concentration (C_{max}) achieved approximately 1 hour post-dose. Based on a mass balance study in humans, oral absorption of ruxolitinib was 95% or greater. Dose proportionality was demonstrated in the single and multiple dose studies. Mean ruxolitinib C_{max} and total exposure (AUC) increased proportionally over a single dose range of 5-200 mg. There was no clinically relevant change in the pharmacokinetics of ruxolitinib upon administration with a high-fat meal. The mean C_{max} was moderately decreased (24%) while the mean AUC was nearly unchanged (4% increase) upon dosing with a high-fat meal.

Distribution: The mean volume of distribution at steady-state is 72 L in myelofibrosis patients with an inter-subject variability of 29.4% and 75 L in polycythemia vera patients with an associated inter-subject variability of 22.6%. At clinically relevant concentrations of ruxolitinib, binding to plasma proteins *in vitro* is approximately 97%, mostly to albumin. A whole body autoradiography study in rats has shown that ruxolitinib does not penetrate the blood-brain barrier.

Metabolism: *In vitro* studies indicate that CYP3A4 is the major enzyme responsible for metabolism of ruxolitinib. Parent compound is the predominant entity in humans representing approximately 60% of the drug-related material in circulation. Two major and active metabolites were identified in plasma of healthy subjects representing 25% and 11% of parent AUC. These metabolites have one half to one fifth of the parent JAK-related pharmacological activity. The sum total of all active metabolites contribute to 18% of the overall pharmacodynamics of ruxolitinib. At clinically relevant concentrations, ruxolitinib does not inhibit CYP1A2, CYP2B6, CYP2C8, CYP2C9, CYP2C19, CYP2D6 or CYP3A4 and is not a potent inducer of CYP1A2, CYP2B6 or CYP3A4 based on *in vitro* and *in vivo* studies.

Excretion: Following a single oral dose of [¹⁴C]-labeled ruxolitinib in healthy adult subjects, elimination was predominately through metabolism with 74% of radioactivity excreted in urine and 22% excretion via feces. Unchanged drug accounted for less than 1% of the excreted total radioactivity. The mean elimination half-life of ruxolitinib is approximately 3 hours.

Special Populations and Conditions

Pediatrics: The safety and effectiveness of JAKAVI in pediatric patients have not been established.

Geriatrics: No additional dose adjustments are recommended for elderly patients. Based on population pharmacokinetic evaluations, no relationship was apparent between oral clearance and age of patients.

Gender or race: Based on population pharmacokinetic evaluations, no relationship was apparent between oral ruxolitinib clearance and patient race.

In myelofibrosis patients, clearance was lower in women (17.7 L/h) compared to men (22.1 L/h), with 39% inter-subject variability. In polycythemia vera patients, clearance was 12.7 L/h, with a 42% inter-subject variability, and no relationship was apparent between oral clearance and gender in this patient population. The reason for the lower ruxolitinib clearance in polycythemia vera patients compared to myelofibrosis patients is unknown.

Hepatic Insufficiency: Following a single ruxolitinib dose of 25 mg in patients with varying degrees of hepatic impairment, the pharmacokinetics and pharmacodynamics of ruxolitinib were assessed. The mean AUC for ruxolitinib was increased in patients with mild [Child-Pugh A (n=8)], moderate [Child-Pugh B (n=8)] and severe hepatic impairment [Child-Pugh C (n=8)] by 87%, 28% and 65%, respectively, compared to patients with normal hepatic function and indicating no clear relationship to the degree of hepatic impairment based on Child-Pugh scores. The terminal elimination half-life was prolonged in patients with hepatic impairment compared to healthy controls (4.1-5.0 hours versus 2.8 hours). A dose reduction is recommended for patients with hepatic impairment (see **DOSAGE AND ADMINISTRATION** section).

Renal Insufficiency: Following a single ruxolitinib dose of 25 mg, the C_{max} and AUC of the parent compound was similar in subjects with mild [CrCl 44-74 mL/min (n=8)], moderate [CrCl 35-47 mL/min (n=8)], or severe [CrCl 7-28 mL/min (n=8)] renal impairment and in those with normal renal function (CrCl 79-122 mL/min in 8 healthy subjects). However, relative AUC values of ruxolitinib metabolites tended to increase with increasing severity of renal impairment, and most markedly in the subjects with end stage renal disease requiring hemodialysis (HD). The relative AUC values of the metabolites corresponded to 61% of the parent compound AUC in healthy normal subjects and increased to 79%, 117% and 173% in subjects with mild, moderate or severe renal impairment, respectively. It increased further to 346% in subjects with ESRD who received HD before dose and to 297% in subjects with ESRD who received HD after dose. The overall pharmacological activity (ruxolitinib + metabolites) was 117% for subjects with normal renal function, 123%, 134%, 153%, 212%, and 192% in subjects with mild, moderate, severe renal impairment, ESRD who received HD before dose, and ESRD who received HD after dose, respectively. Based on the overall pharmacological activity (ruxolitinib + metabolites) and potential metabolite accumulation in renal patients, dose modifications is conservatively proposed in the moderate, severe renal impaired and ESRD patients (see **DOSAGE AND ADMINISTRATION** section).

STORAGE AND STABILITY

Store between 15 - 25°C.

JAKAVI must be kept out of the reach and sight of children.

SPECIAL HANDLING INSTRUCTIONS

No special handling requirements.

Special precautions for disposal

Any unused product or waste material should be disposed of in accordance with local requirements.

DOSAGE FORMS, COMPOSITION AND PACKAGING

JAKAVI (*ruxolitinib* tablets) is available in four strengths. Each tablets contains 5 mg, 10 mg, 15 mg or 20 mg ruxolitinib free base (as ruxolitinib phosphate).

JAKAVI (ruxolitinib tablets) 5 mg tablets:

Round curved white to almost white tablets with “NVR“ debossed on one side and “L5” debossed on the other side.

JAKAVI (ruxolitinib tablets) 10 mg tablets:

Round curved white to almost white tablets with “NVR” debossed on one side and “L10” debossed on the other side.

JAKAVI (ruxolitinib tablets) 15 mg tablets:

Ovaloid curved white to almost white tablet with “NVR“ debossed on one side and “L15” debossed on the other side.

JAKAVI (ruxolitinib tablets) 20 mg tablets:

Elongated curved white to almost white tablet with “NVR“ debossed on one side and “L20” debossed on the other side.

Non-medicinal ingredients: hydroxypropylcellulose, lactose monohydrate, magnesium stearate, microcrystalline cellulose, colloidal silicon dioxide, sodium starch glycolate (Type A), povidone.

Each 5 mg tablet contains 71.45 mg of lactose monohydrate;

Each 10 mg tablet contains 142.90 mg of lactose monohydrate;

Each 15 mg tablet contains 214.35 mg of lactose monohydrate;

Each 20 mg tablet contains 285.80 mg of lactose monohydrate.

Availability

JAKAVI (ruxolitinib tablets) 5 mg, 10 mg, 15 mg and 20 mg tablets are supplied in blister packaging (4x14 tablets).

PART II: SCIENTIFIC INFORMATION

PHARMACEUTICAL INFORMATION

Drug Substance

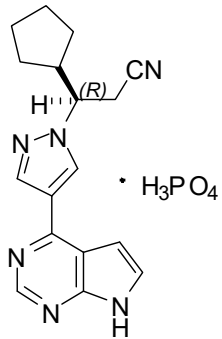
- Proper name: Ruxolitinib phosphate
- Chemical name: (*R*)-3-(4-(7*H*-pyrrolo[2,3-*d*]pyrimidin-4-yl)-1*H*-pyrazol-1-yl)-3-cyclopentylpropanenitrile phosphate
1*H*-Pyrazole-1-propanenitrile,β-cyclopentyl-4-(7*H*-pyrrolo[2,3-*d*]pyrimidin-4-yl)-,(β*R*)-, phosphate (1:1)
- Molecular formula: Salt form on anhydrous basis: C₁₇H₁₈N₆.H₃PO₄
- Molecular mass: Salt form on anhydrous basis: 404.36
Free base form: 306.37
Salt/base ratio on anhydrous basis: 1.320
- Structural formula: 
- Physicochemical properties:**
- Physical Description: White to almost white powder
- Solubility: Ruxolitinib phosphate is highly soluble in water. Ruxolitinib phosphate solubility in aqueous medium is pH dependent. Ruxolitinib phosphate is soluble in apolar organic solvents at 25°C and 50°C.

pH: The pH value of a saturated solution of ruxolitinib phosphate in water (46 mg/mL) was measured potentiometrically at room temperature and was determined to be 2.5.

pKa: 4.3 and 11.8

Partition Coefficient: Ruxolitinib phosphate in octanol/aqueous buffers exhibits a partition coefficient of less than 1 in the octanol/pH 1.0 buffer system and becomes more hydrophobic at pH 7.4 (the physiological pH of blood serum).

Melting point: 194 - 198°C (as determined by differential scanning calorimetry (DSC)).

CLINICAL TRIALS

Myelofibrosis

Study demographics and trial design

The clinical efficacy of JAKAVI in patients with Myelofibrosis (Primary Myelofibrosis (MF), Post-Polycythemia Vera Myelofibrosis (PPV-MF) or Post-Essential Thrombocythemia-Myelofibrosis (PET-MF)), has been demonstrated based on the two Phase III Studies (COMFORT I and COMFORT II).

Table 10 Summary of patient demographics for MF clinical trials (Intent To Treat (ITT))

Study	Trial design	Dosage, route of administration and duration	Study subjects (n=number)	Mean age (Range)	Gender
COMFORT-I	Phase 3 double-blind, randomized, placebo-controlled study of the JAK inhibitor ruxolitinib in adult patients with MF, including PMF, PPV-MF, or PET-MF.	Ruxolitinib and the placebo were administered orally: Starting dose based on baseline platelet count: -between 100,000 and 200,000/mm ³ 15 mg b.i.d. - > 200,000/mm ³ 20 mg b.i.d.	Total number of patients: 309 Ruxolitinib: 155 Placebo: 154	Ruxolitinib: 45.2% ≤ 65 years 54.8% > 65 years Mean: 66.7 Range: 43.0, 91.0 Placebo: 33.8% ≤ 65 years 66.2% > 65 years Mean: 68.7 Range: 40.0, 86.0	Ruxolitinib: M: 51% F: 49% Placebo: M: 57.1% F: 42.2%
COMFORT-II	Phase 3 open-label, randomized study of the JAK inhibitor ruxolitinib versus best available therapy (BAT) in adult patients with MF, including PMF, PPV-MF, or PET-MF.	Ruxolitinib and BAT were administered orally: Starting dose based on baseline platelet count: between 100,000 and 200,000/mm ³ 15 mg b.i.d. - > 200,000/mm ³ 20 mg b.i.d.	Total number of patients: 219 Ruxolitinib: 146 BAT: 73	Ruxolitinib: 47.3% ≤ 65 years 52.7% > 65 years Mean: 65.1 Range: 35.0, 83.0 BAT: 49.3% ≤ 65 years 50.7% > 65 years Mean: 65.2 Range: 35.0, 85.0	Ruxolitinib: M: 56.8% F: 43.2% BAT: M: 57.5% F: 42.5%

In both studies, patients had palpable splenomegaly at least 5 cm below the costal margin and risk category of intermediate 2 (2 prognostic factors) or high risk (3 or more prognostic factors)

based on the International Prognostic Scoring System (IPSS). The prognostic factors that comprise the IPSS criteria consist of age > 65 years, presence of constitutional symptoms (weight loss, fever, night sweats), anemia (hemoglobin < 10 g/dL), leukocytosis (history of WBC > 25 X 10⁹/L) and circulating blasts ≥ 1%.

The starting dose of JAKAVI was based on platelet count. Patients with a platelet count between 100,000 and 200,000/mm³ were started on JAKAVI 15 mg twice daily and patients with a platelet count > 200,000/mm³ were started on JAKAVI 20 mg twice daily. Doses were then individualized based upon tolerability and efficacy.

COMFORT-I was a double-blind, randomized, placebo-controlled study in 309 patients who were refractory to or were not candidates for available therapy. Patients were dosed with JAKAVI or matching placebo. The primary efficacy endpoint was the proportion of subjects achieving ≥ 35% reduction from baseline in spleen volume at week 24 as measured by Magnetic Resonance Imaging (MRI) or Computerized Axial Tomography (CAT).

Secondary endpoints included duration of maintenance of a ≥ 35% reduction from baseline in spleen volume, proportion of patients who had ≥ 50% reduction in total symptom score from baseline to week 24 as measured by the modified Myelofibrosis Symptom Assessment Form (MFSAF) v2.0 diary, change in total symptom score from baseline to week 24 as measured by the modified MFSAF v2.0 diary and overall survival.

COMFORT-II was an open-label, randomized study in 219 patients. Patients were randomized 2:1 to JAKAVI versus best available therapy. Best available therapy was selected by the investigator on a patient-by-patient basis. In the best available therapy arm, 47% of patients received hydroxyurea and 16% of patients received glucocorticoids. The primary efficacy endpoint was the proportion of patients achieving ≥ 35% reduction from baseline in spleen volume at week 48 as measured by MRI or CT.

A secondary endpoint in COMFORT-II was the proportion of patients achieving a ≥ 35% reduction of spleen volume measured by MRI or CT from baseline to week 24. Duration of maintenance of a ≥ 35% reduction from baseline in responding patients was also a secondary endpoint.

In COMFORT-I, patient baseline demographics and disease characteristics were comparable between the treatment arms. The median age was 68 years with 61% of patients older than 65 years and 54% male. Fifty percent (50%) of patients had primary myelofibrosis, 31% had post-polycythemia myelofibrosis and 18% had post-essential thrombocythemia myelofibrosis based on investigator assessment. Twenty-one (21%) of patients had red blood transfusions within 8 weeks of enrollment in the study.

The median platelet count was 251,000/mm³. Seventy-six percent of patients had the mutation encoding the V617F substitution present in the JAK protein. Patients had a median palpable spleen length of 16 cm. At baseline 37.4% of the patients in the JAKAVI arm had Grade 1 anemia, 31.6% Grade 2 and 4.5% Grade 3, while in the placebo arm 35.8% had Grade 1, 35.1% Grade 2, 4.6% Grade 3, and 0.7% Grade 4. Grade 1 thrombocytopenia was found in 12.9 % of patients in the JAKAVI arm and 13.2% in the placebo arm.

In COMFORT-II, patient baseline demographics and disease characteristics were comparable between the treatment arms. The median age was 66 years with 52% of patients older than 65 years and 57% male. Fifty-three percent (53%) of the subjects had primary myelofibrosis,

31% had post-polycythemia vera myelofibrosis, and 16% had post-essential thrombocythemia myelofibrosis based on investigator assessment. 19% of patients were considered transfusion dependent at baseline. Patients had a median palpable spleen length of 15 cm.

At baseline 34.2% of the patients in the JAKAVI arm had Grade 1 anemia, 28.8% Grade 2, and 7.5% Grade 3, while in the BAT arm 37% had Grade 1, 27.4% Grade 2, 13.7% Grade 3, and 1.4% Grade 4. Thrombocytopenia of Grade 1 was found in 8.2% of patients in the JAKAVI arm, and 9.6% in the BAT arm.

Study results

Efficacy analyses of the primary endpoint in COMFORT-I and COMFORT-II are presented in Table 1 below. A significantly larger proportion of patients in the JAKAVI group achieved a $\geq 35\%$ reduction in spleen volume from baseline in both studies compared to placebo in COMFORT-I and best available therapy in COMFORT-II.

Table 11 Percent of Patients with $\geq 35\%$ Reduction from Baseline in Spleen Volume at week 24 in COMFORT-I and at week 48 in COMFORT-II (ITT analysis)

	COMFORT-I		COMFORT-II	
	JAKAVI (N=155)	Placebo (N=153)	JAKAVI (N=144)	Best Available Therapy (N=72)
Time Points	week 24		week 48	
Number (%) of Subjects with Spleen Volume Reduced by $\geq 35\%$	65 (41.9)	1 (0.7)	41 (28.5)	0
95% Confidence Intervals	34.1, 50.1	0, 3.6	21.3, 36.6	0.0, 5.0
P-value	< 0.0001		< 0.0001	

In COMFORT-I, 41.9% of patients in the JAKAVI group achieved a $\geq 35\%$ reduction in spleen volume from baseline compared with 0.7% in the placebo group at week 24. In an exploratory analysis, a similar proportion of patients in the JAKAVI group achieved a $\geq 50\%$ reduction in palpable spleen length.

In COMFORT-II, 28.5% of patients in the JAKAVI group achieved a $\geq 35\%$ reduction in spleen volume from baseline compared with none (0%) in the best available therapy group at week 48. A secondary endpoint was the proportion of patients achieving a $\geq 35\%$ reduction of spleen volume at week 24. A significantly larger proportion of patients in the JAKAVI group 46

(31.9%) achieved a $\geq 35\%$ reduction in spleen volume from baseline compared to no (0%) patients in the best available therapy group (p -value < 0.0001).

A significantly higher proportion of patients in the JAKAVI group achieved $\geq 35\%$ reduction from baseline in spleen volume regardless of the presence or absence of the JAK2^{V617F} mutation or the disease subtype (primary myelofibrosis, post-polycythemia vera myelofibrosis, post-essential thrombocythemia myelofibrosis).

Figure 1 shows a waterfall plot of the percent change from baseline in spleen volume at week 24 in COMFORT-I. Among the 139 patients in the JAKAVI group who had both baseline and Week 24 spleen volume evaluations, all but two patients had some level of reduction in spleen volume at week 24, with a median reduction of 33%. Among the 106 patients in the placebo group who had both baseline and week 24 spleen volume evaluations, there was a median increase of 8.5%.

Figure 1 Waterfall Plot of Percent Change From Baseline in Spleen Volume at week 24 (Observed Cases) COMFORT- I

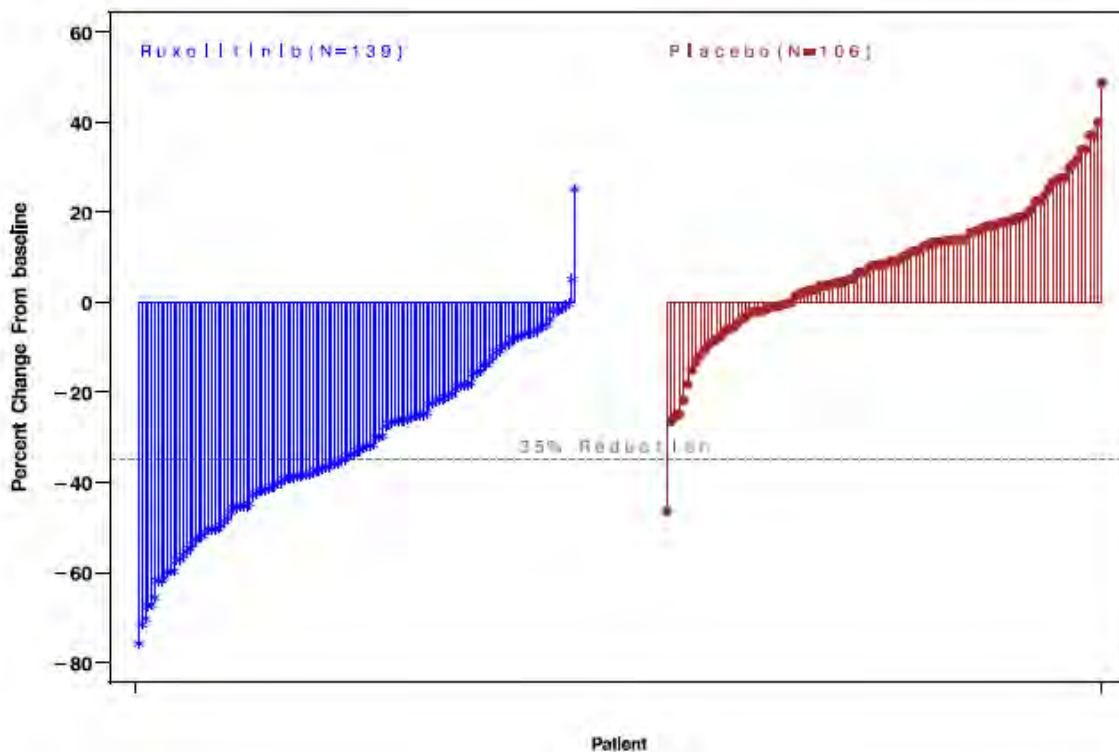
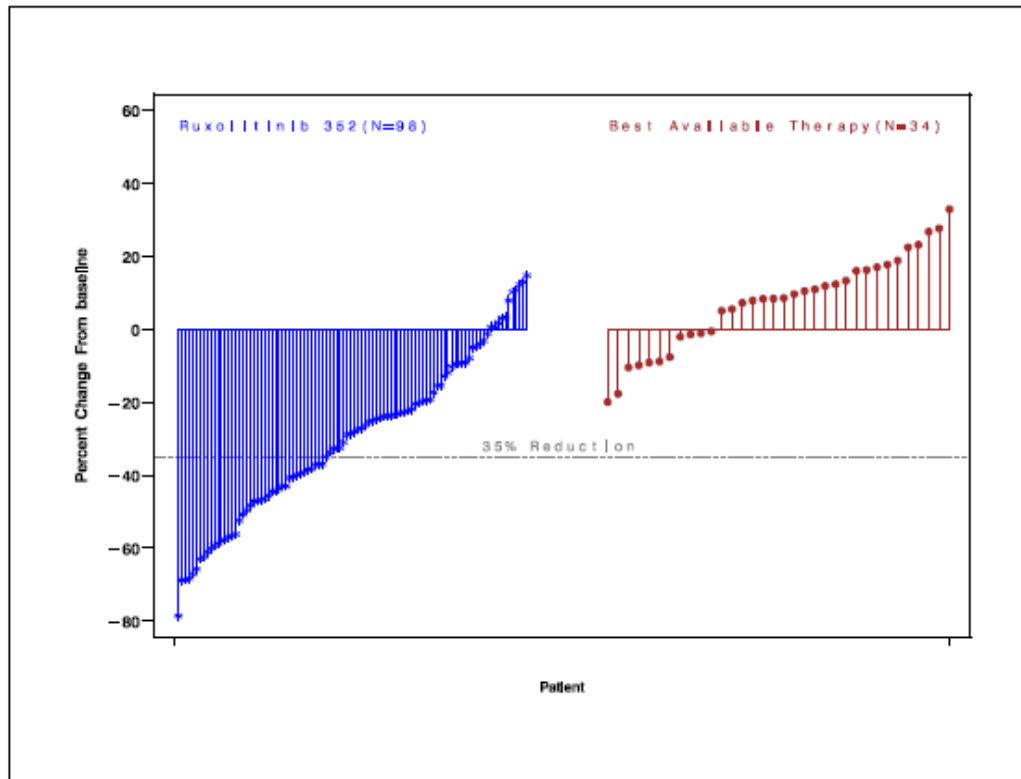

Figure 2 shows a waterfall plot of the percent change from baseline in spleen volume at week 48 in COMFORT-II. Among the 98 patients in the JAKAVI group who had both baseline and week 48 spleen volume evaluations, the median reduction in spleen volume at week 48 was 28%. Among the 34 patients in the Best Available Therapy group who had both baseline and week 48 spleen volume evaluations, there was a median increase of 8.5%.

Figure 2 Waterfall Plot of Percent Change from Baseline in Spleen Volume at week 48 in COMFORT-II



JAKAVI improves myelofibrosis-associated symptoms in patients with PMF, PPV-MF and PET-MF. In COMFORT-I symptoms of MF were captured using the modified MFSAF diary v2.0 as an electronic diary, which subjects completed daily. The modified MFSAF is a daily diary capturing the core symptoms of myelofibrosis (abdominal discomfort, pain under left ribs, night sweats, itching, bone/muscle pain and early satiety). Symptom scores ranged from 0 to 10 with 0 representing symptoms “absent” and 10 representing “worst imaginable” symptoms. These scores were added to create the daily total score, which has a maximum of 60. A significantly larger proportion of subjects in the JAKAVI group achieved a $\geq 50\%$ improvement from Baseline in the week 24 total symptom score compared with the placebo group (45.9% and 5.3%, respectively, $p < 0.0001$ using the Chi-Squared test).

In an exploratory analysis, an improvement in overall quality of life was measured by a validated instrument, the EORTC QLQ-C30 in both COMFORT-I and COMFORT-II. At week 24 in COMFORT-I the mean change for the global health status/quality of life score was +12.3 and -3.4 ($p < 0.0001$) for JAKAVI and placebo, respectively.

In COMFORT-I, at the updated final analysis, conducted after a median follow-up of 5.2 years, a total of 69 (44.5%) and 82 (53.2%) patients died in the ruxolitinib and placebo arms, respectively (HR 0.69; 95% CI: 0.50-0.96, $p=0.025$).

In COMFORT-II, at the updated final analysis, conducted after a median follow-up of 4.7 years, a total of 94 patients died overall, 59 (40.4%) and 35 (47.9%) patients died in the ruxolitinib and Best available therapy (BAT) arms, respectively (HR 0.67; 95% CI: 0.44-1.02, $p=0.062$).

Polycythemia vera

Study demographics and trial design

The clinical efficacy of JAKAVI in patients with Polycythemia vera has been demonstrated based on a Phase III study (RESPONSE).

Table 12 Summary of patient demographics for the PV clinical trial (ITT)

Study	Trial design	Dosage and route of administration	Study subjects (n=number)	Mean age (Range)	Gender
RESPONSE (Study B2301)	Phase 3, open-label, randomized, controlled study comparing the efficacy and safety of the JAK inhibitor ruxolitinib to Best Available Therapy (BAT) in adult patients with PV who were resistant to or intolerant of hydroxyurea. The patients randomized to the BAT could crossover to ruxolitinib at week 32 if they failed to meet the primary endpoint, and after week 32 if they did not achieve HCT control (absence of phlebotomy eligibility) or had a spleen volume progression.	Ruxolitinib was administered orally at a starting dose of 10 mg twice daily (doses were then adjusted in individual patients based on tolerability and efficacy) BAT was selected on a patient-by-patient basis and included hydroxyurea (59.5% of patients), interferon/pegylated interferon (11.7% of patients), anagrelide (7.2% of patients), pipobroman (1.8% of patients) and observation (15.3% of patients)	Total number of patients: 222 Ruxolitinib: 110 BAT: 112	Ruxolitinib: Median age: 62 years Mean: 61.1 years (34-90 years) BAT: Median age: 60 years Mean: 59.1 years (33-84 years)	Ruxolitinib: M: 60% F: 40% BAT: M: 71.4% F: 28.6%

The study was conducted in 222 patients with polycythemia vera who were resistant to or

intolerant of hydroxyurea as per the modified European Leukemia Net (ELN) international working group consensus.

Baseline demographics and disease characteristics were comparable between the two treatment groups. The median age was 60 years (range 33 to 90 years). The proportion of patients with the JAK2^{V617} mutation was 94.5% (104) in the JAKAVI group and 95.5% (107) in the BAT group respectively. For patients in the JAKAVI group and the BAT group, the median time since the diagnosis of PV was 8.2 years and 9.3 years respectively and they had previously received hydroxyurea for a median duration of approximately 3 years in both groups. Most patients (> 80%) had received at least two phlebotomies in the last 24 weeks prior to screening. All patients had splenomegaly ($\geq 450 \text{ mm}^3$) at study entry and their hematocrit was to be normalized to levels between 40-45% within 14 days before the day 1 visit. All randomized subjects in the study received concomitant low dose aspirin (75-150 mg/day) unless medically contraindicated. In this case, other prophylactic antithrombotic agents may have been used.

Study Results:

The primary endpoint was the proportion of patients achieving both the absence of phlebotomy eligibility (hematocrit (HCT) control) and $\geq 35\%$ reduction in spleen volume from baseline at week 32. Hematocrit control was defined as the absence of phlebotomy eligibility beginning at the week 8 and continuing through week 32, with no more than one phlebotomy eligibility occurring post-randomization and prior to week 8. Phlebotomy eligibility was defined as a confirmed HCT $> 45\%$ that is at least 3 percentage points higher than the HCT obtained at baseline or a confirmed HCT $> 48\%$, whichever is lower. Key secondary endpoints included the proportion of patients who achieved the primary endpoint and who remained free from progression at week 48, and the proportion of patients achieving complete hematological remission at Week 32 with complete hematological remission defined as achieving hematocrit control, platelet count less than or equal to $400 \times 10^9/\text{L}$, and white blood cell count less than or equal to $10 \times 10^9/\text{L}$.

A higher proportion of patients in the JAKAVI group achieved the primary composite endpoint and each of its individual components. Significantly more patients in the JAKAVI group (23%) compared to the BAT group (0.9%) achieved the primary composite endpoint ($p < 0.0001$). Hematocrit control was achieved in 60% of patients in the JAKAVI group compared to 18.75% in the BAT group and $\geq 35\%$ reduction in spleen volume was achieved in 40% of patients in the JAKAVI group compared to 0.9% in the BAT group (Figure 3).

Both key secondary endpoints were also met: The proportion of patients achieving a complete hematologic remission at week 32 was 23.6% in the JAKAVI group compared to 8.0% in the BAT group ($p = 0.0013$), and the proportion of patients achieving a durable primary response at week 48 was 20% in the JAKAVI group and 0.9% in the BAT group ($p < 0.0001$), which represent 91.3% ($n = 21/n = 23$) of patients in the JAKAVI group who achieved the primary endpoint at week 32 and maintained it at week 48.

Figure 3 Patients achieving the primary endpoint and components of the primary endpoint at Week 32

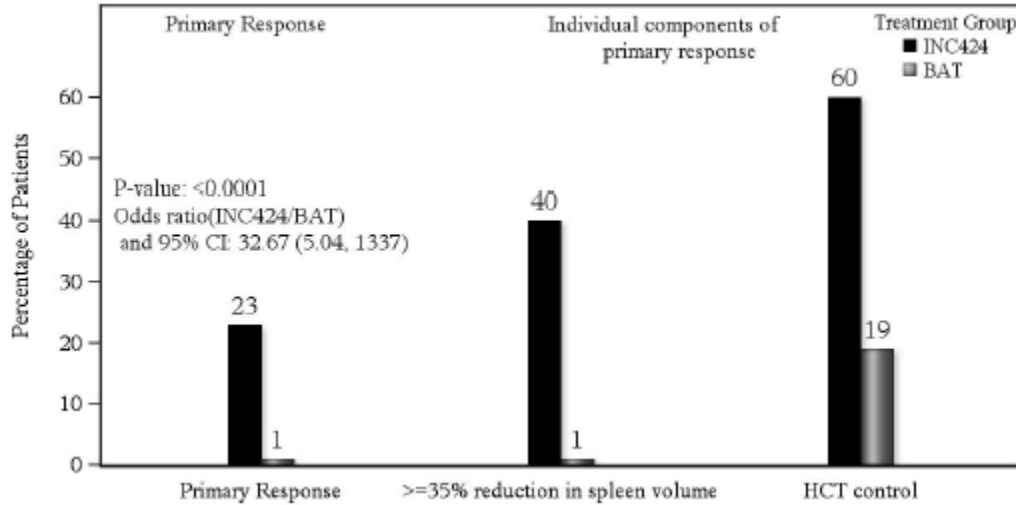

Additional analyses from the RESPONSE study to assess durability of response were conducted at Week 80 only in the JAKAVI arm. In this arm, 83% (n=91) of patients were still on treatment at the time of the Week 80 data cut-off. Of patients (n=25) who achieved a primary response at Week 32, 80% (n=20) maintained their response for at least 48 weeks after the initial response.

RESPONSE 2 is a randomized, open label, active-controlled phase IIIb study. The primary endpoint was defined as the proportion of patients achieving HCT control (absence of phlebotomy eligibility) at Week 28. The study met its primary objective with a higher proportion of patients who were resistant to or intolerant of hydroxyurea but without palpable splenomegaly in the JAKAVI arm (62.2%, n=46) compared to the BAT arm (18.7%, n=14) achieving the primary endpoint of HCT control (p<0.0001).

DETAILED PHARMACOLOGY

Pharmacodynamics

In vitro data demonstrate that ruxolitinib is an inhibitor of JAK1 (IC_{50} 3.3 ± 1.2 nM) and JAK2 (IC_{50} 2.8 ± 1.2 nM), compared to the other two JAK family members, TYK2 (IC_{50} 19 ± 3.2 nM) and JAK3 (IC_{50} 428 ± 243 nM). Moreover ruxolitinib inhibits proliferation (IC_{50} 141 nM) and STAT3 phosphorylation (IC_{50} 125 nM) in a cytokine dependent, JAK wild-type INA-6 multiple myeloma cell line. Additionally, inhibition of proliferation (IC_{50} 127 nM) and JAK2/STAT5/ERK phosphorylation (IC_{50} 128-320nM) was observed in a pro-B-cell Ba/F3 cell line rendered cytokine-independent and JAK2^{V617F}-dependent by expression of JAK2^{V617F} and the erythropoietin receptor (EpoR).

In vivo, ruxolitinib was examined in models relevant to myeloproliferative neoplasms (MPN). Treatment of mice with ruxolitinib resulted in a dose-dependent suppression of phosphorylated STAT3 and tumor growth in the cytokine-dependent, JAK wild type INA-6 multiple myeloma xenograft model. In the mutant JAK2^{V617F}-driven Ba/F3-EpoR xenograft mouse model ruxolitinib treatment suppressed splenomegaly mutant allele burden (33% decrease, $P < 0.01$), and circulating inflammatory cytokines (TNF- α and IL-6). Furthermore, treatment of mice with ruxolitinib normalized aberrantly activated JAK/STAT signaling, as indicated by assessing levels of phosphorylated STAT3 in spleen lysates. Mice bearing Ba/F3-EpoR-JAK2^{V617F} cells and treated with ruxolitinib had a significantly improved survival compared to animals treated with vehicle. After 3 weeks of treatment, > 90% of vehicle-treated mice had succumbed to disease while > 90% of ruxolitinib-treated mice survived.

Safety pharmacology

Ruxolitinib was evaluated in a safety pharmacology core battery of studies that included CNS and respiratory studies in the rat, a cardiovascular study in telemeterized conscious dogs, and in an *in vitro* hERG channel assay.

Safety pharmacology of ruxolitinib in vitro did not demonstrate strong inhibition of hERG (IC_{50} 132 μ M) in a transfected cell line originally derived from human embryonic kidney cells (HEK293). In vivo safety pharmacology of ruxolitinib in rats and dogs yielded adverse effects in respiratory, CNS and cardiovascular function at exposures that exceeded those observed in human studies. The effects in the respiratory study included lower respiratory rates, higher tidal volumes and lower minute volumes and occurred at an exposure approximately 50-fold or 22 fold the exposure at the maximum human recommended dose (based on free C_{max} or AUC, respectively). The effects in the CNS studies were characterized by lower body temperature, lower activity and they occurred at an exposure approximately 2.6-fold or 0.7-fold (in males based on free C_{max} or AUC, respectively) and 50-fold or 22-fold (in females based on free C_{max} or AUC, respectively) the exposure at the maximum human recommended dose. In the cardiovascular assessment study, lower systolic and diastolic pressure, increased heart rate, decreased mean and pulse arterial pressure were observed at an exposure approximately 36-fold or 49-fold the exposure at the maximum human recommended dose (based on free C_{max} or AUC,

respectively). These in vivo safety pharmacology observations have not been observed in the repeat-dose toxicity studies or recapitulated in the clinical studies.

Pharmacokinetics

ADME studies were performed in mouse, rat, minipig and dog. Notably, these studies revealed that ruxolitinib was neither an inhibitor nor a substrate of P-gp. Ruxolitinib is highly soluble (pH 1.0-8.0) and permeable with a range of bioavailability (22-105%) dependant on the species. In humans, greater than 45% of ruxolitinib was absorbed after oral administration, which was similar to that of dogs. The mean ex vivo unbound plasma fraction post ruxolitinib treatment was 2.7-4.9% in mice, 18% in rats, 13% in rabbits, 9.7% in dogs and 33% in minipigs. Similar values were observed for their in vitro unbound fractions. The mean in vitro unbound fraction for human plasma was 3.3%. Upon entry into circulation, ruxolitinib was rapidly and widely distributed in rats (i.e. to gastrointestinal system, urinary bladder, liver, renal cortex, aorta and adrenal glands, skin, kidney) with maximal serum levels detected 0.5-2 hours post-oral administration. Notably, ruxolitinib and its metabolites crossed the blood brain barrier (<10% of plasma concentrations) and placental barrier of rats. Ruxolitinib and its metabolites transferred substantially into the milk of lactating rats. Ruxolitinib related radioactivity was eliminated within 24 hours. In bile duct cannulated rats, a majority of radioactivity was recovered in the urine (50%) followed by bile (37%) and feces (12%). In dogs, radioactivity was recovered in the urine (34-36%) and feces (55-58%). Renal excretion of unchanged ruxolitinib was very limited (<1% of dose).

In vivo metabolism of ruxolitinib resulted in over 50 metabolites across various animal species. In humans, most of these metabolites had some PD activity as measured by activated STAT3. Ruxolitinib was eliminated predominantly by oxidative metabolism followed in some cases by limited subsequent glucuronidation in humans and animal species. The main circulating human metabolite was identified as M18, which represented 25% of parent compound exposure. Like ruxolitinib, M18 did not inhibit efflux (MXR and MDR1) and uptake transporters (OATP1B1, OATP1B3, OAT1, OAT3, OCT1 and OCT2). Moreover, M18 did not inhibit CYP3A4, CYP1A2, CYP2B6, CYP2C8, CYP2C9, CYP2C19 and CYP2D6.

Human studies on drug interactions

Clinically relevant drug interactions are discussed in Part I (see **DRUG INTERACTIONS** section).

CYP3A4 inducers:

In healthy subjects receiving rifampin, a potent CYP3A4 inducer, at 600 mg once daily for ten days, the AUC of ruxolitinib following a single dose decreased by 71% and the half-life decreased from 3.3 to 1.7 hours. The relative exposure of the active metabolites to parent compound doubled as a result of rifampin co-administration. The overall pharmacodynamic marker pSTAT3 inhibition was reduced by only 10% which may be explained by the increased exposure of the active metabolites as well as decreased exposure of the parent compound.

CYP3A4 substrates: A study in healthy subjects indicated that JAKAVI had no clinically significant pharmacokinetic interaction with midazolam (CYP3A4 substrate).

Oral contraceptives: A study in healthy subjects indicated that JAKAVI does not affect the pharmacokinetics of an oral contraceptive containing ethinylestradiol and levonorgestrel. Therefore contraceptive efficacy of this combination is not expected to be compromised by co-administration with ruxolitinib.

TOXICOLOGY

Single oral dose toxicity

Ruxolitinib was well tolerated following single oral doses of up to 100 mg/kg in rats and 40 mg/kg in dogs. Mild lethargy and emesis were respectively observed at a dose of 100mg/kg in rats (exposure approximately equal or 6.4-fold the exposure at the maximum human recommended dose based on AUC in males and females, respectively) or 40 mg/kg in dogs (exposure approximately 7.9-fold the exposure at the maximum human recommended dose based on AUC). In the rat study assessing the CNS function, darkened mucous membranes and skin were noted at an exposure approximately 0.10-fold or 3.8-fold the exposure at the maximum human recommended dose (based on AUC, in males and females, respectively).

Repeated oral dose toxicity

Repeated oral dose studies with ruxolitinib of up to 4 weeks in mice, 6 months in rats, and 12 months in the dog were conducted.

Target organs associated with the pharmacological action of ruxolitinib in repeat dose studies include bone marrow, peripheral blood and lymphoid tissues at an exposure approximately 3-fold or 0.7-fold the exposure at the maximum human recommended dose based on AUC in rats and dogs, respectively. Findings were reversible or demonstrated a tendency for reversibility. Specific findings include, decreases in lymphocytes, eosinophils, reticulocytes, red blood cell, hemoglobin and hematocrit as well as hypocellularity of the bone marrow and lymphoid organs (spleen, thymus, lymph nodes). Dogs (6 & 12 month study) developed bacterial, parasitic and viral infections that are generally associated with immunosuppression (at an exposure approximately equal to the exposure at the maximum human recommended dose based on AUC).

Other findings include gastrointestinal inflammation (4 week dog study; at an exposure approximately 5-fold the exposure at the maximum human recommended dose based on AUC), prostatic atrophy (6 month dog study; at an exposure approximately 1.9-fold the exposure at the maximum human recommended dose based on AUC), heart fibrosis (13 week female rat study; at an exposure approximately 9.5-fold the exposure at the maximum human recommended dose based on AUC), adrenal cortical atrophy (6 month rat study; at an exposure approximately 0.14-fold the exposure at the maximum human recommended dose based on AUC), hyperplasia of non-glandular stomach (4 week mouse study; at an exposure approximately 6.5-fold the exposure at the maximum human recommended dose based on AUC), increases of ALP and GGT (13 week female rat study; at an exposure approximately 9.6-fold the exposure at the maximum human recommended dose based on AUC), and decreases in phosphorous and

calcium levels (dog ≥ 5 mg/kg/day; at an exposure approximately 1.6-fold the exposure at the maximum human recommended dose based on AUC).

Genotoxicity

As a single agent, ruxolitinib did not test positive for mutagenicity in a bacterial mutagenicity assay (Ames test) or clastogenicity in an *in vitro* chromosomal aberration assay (cultured human peripheral blood lymphocytes) or *in vivo* rat bone marrow micronucleus assay.

Carcinogenesis

In a 6-month carcinogenicity study, no significant increase in neoplastic lesions was observed in the Tg.RasH2 transgenic mouse model at C_{max} and AUC exposures that exceeded (8-fold) those observed in clinical studies. Non-neoplastic intranasal inflammation was observed in the treated mouse model at an exposure approximately 8-fold the exposure at the maximum human recommended dose based on AUC. Together, ruxolitinib was not carcinogenic in the Tg.rasH2 transgenic mouse model nor in a 2-year study in rats.

Reproductive and developmental toxicity studies

Administration of ruxolitinib to juvenile rats resulted in effects on growth and bone measures. Ruxolitinib was administered daily by oral gavage at doses from 1.5 to 75 mg/kg/day from days 7 (the human equivalent of a newborn) to 63 post-partum (pp), 15 mg/kg/day from days 14 (the human equivalent of 1 year of age) to 63 pp and 5, 15 and 60 mg/kg/day from days 21 (the human equivalent of 2 to 3 years of age) to 63 pp. Doses ≥ 30 mg/kg/day (1,200 ng*h/mL based on unbound AUC) resulted in fractures and early termination of the groups when treatment started on day 7 pp. Reduced bone growth was observed at doses ≥ 5 mg/kg/day (≥ 150 ng*h/mL based on unbound AUC) when treatment started on day 7 pp and at ≥ 15 mg/kg/day (≥ 150 ng*h/mL based on unbound AUC) when treatment started on day 14 pp or day 21 pp. Based on unbound AUC, fractures and reduced bone growth occurred at exposures 13- and 1.5- fold the exposure in adult patients at the maximum recommended dose of 25 mg BID, respectively. The effects were generally more severe when administration was initiated earlier in the postnatal period. Other than the effects on bone development, the toxicity profile in juvenile rats was comparable to that observed in adult rats.

Ruxolitinib was not teratogenic but was associated with maternal toxicity, embryoletality (increases in post implantation loss resulting in decreased litter sizes) and fetotoxicity (decreased fetus weights) in rats and rabbits. No effects were noted on reproductive performance or fertility. In a pre- and post-natal development study, there were no adverse findings for fertility indices and maternal and embryofetal survival, growth, and developmental parameters. All of the observations in this section occur at exposures that are significantly less than those observed in the clinical populations (at an exposure approximately 0.07 to 0.34-fold the maximum human recommended dose based on AUC).

Phototoxicity

Ruxolitinib absorbs light in the range of 290 to 700 nm, with a peak at 310 nm. In studies performed on guinea pigs, ruxolitinib did not show any photoallergic or phototoxic potential when applied either topically or dermally at concentrations $\leq 1.5\%$. Repeated daily topical administration with or without simulated sunlight in hairless mice for a period of 13 weeks did not result in adverse findings. No phototoxicity or photoallergy or irritancy studies have been performed via the oral route of administration.

REFERENCES

1. [Abdel-Wahab OI, Levine RL (2009)] Primary myelofibrosis: update on definition, pathogenesis, and treatment. *Annu Rev Med* 60:233-45.
2. [Barosi G, Rosti V, Vannucchi AM (2011)] Therapeutic approaches in myelofibrosis. *Expert Opin Pharmacother* 2011 Apr 4.
3. [Cervantes F, Dupriez B, Pereira A, et al (2009)] New prognostic scoring system for primary myelofibrosis based on a study of the International Working Group for Myelofibrosis Research and Treatment. *Blood* 113(13):2895-901.
4. [Harrison C, Kiladjian J, Kathrin Al-Ali H, et al (2012)] JAK Inhibition with Ruxolitinib versus Best Available Therapy for Myelofibrosis. *N Engl J Med*; 366:787-98.
5. [Levine RL, Gilliland DG (2008)] Myeloproliferative disorders. *Blood* 112(6):2190-8.
6. [Mesa RA (2010)] Assessing New Therapies and Their Overall Impact in Myelofibrosis. *Hematology Am Soc Hematol Educ Program* 115-21.
7. [Mesa RA, Verstovsek S, Cervantes F et al (2007)] Primary Myelofibrosis (PMF), post polycythemia vera myelofibrosis (post-PV MF), post essential thrombocythemia myelofibrosis (post-ET MF), blast phase PMF (PMF-BP): Consensus on terminology by the international working group for myelofibrosis research and treatment (IWG-MRT). *Leukemia Res*; 31:737-740.
8. [Passamonti F, Cervantes F, Vannucchi AM, et al (2010)] Dynamic International Prognostic Scoring System (DIPSS) predicts progression to acute myeloid leukemia in primary myelofibrosis. *Blood* 116(15):2857-8.
9. [Scherber R, Dueck AC, Johansson P et al (2011)] The myeloproliferative neoplasm symptom assessment form (MPN-SAF): international prospective validation and reliability trial in 402 subjects. *Blood* (pre-published online 2-May-2011, doi:10.1182/blood-2011-01-328955).
10. [Shi JG, Chen X, Emm T, et al.] (2012) The Effect of CYP3A4 Inhibition or Induction on the Pharmacokinetics and Pharmacodynamics of Orally Administered Ruxolitinib (INCB018424 Phosphate) in Healthy Volunteers, *J Clin Pharmacol.* 52 (6): 809-18.
11. [Shi JG, Chen X, McGee RF, et al (2011)] The Pharmacokinetics, Pharmacodynamics, and Safety of Orally Dosed INCB018424 Phosphate in Healthy Volunteers. *J Clin Pharmacol.* 51 (12): 1644-54.

12. [Shilling AD, Nedza FM, Emm T, et al (2010)] Metabolism, excretion, and pharmacokinetics of [14C]INCB018424, a selective Janus tyrosine kinase 1/2 inhibitor, in humans. *Drug Metab Dispos.* 2010 Nov; 38(11):2023-31.
13. [Vannucchi A.M, Kiladjian J.J, Griesshammer m., et al (2015)] Ruxolitinib versus Standard Therapy for the Treatment of Polycythemia Vera *N Engl J Med*; 372:426-35 and Supplementary Appendix.
14. [Vannucchi A.M, Kantarjian, H.M, Kiladjian, J.J., et al (2015)] A pooled analysis of overall survival in COMFORT-I and COMFORT-II, 2 randomized phase III trials of ruxolitinib for the treatment of myelofibrosis. *Haematologica*; 2015; 100(9).
15. [Verstovsek S., Passamonti F., Rambaldi A., et al (2014)] A Phase 2 Study of Ruxolitinib, an Oral JAK1 and JAK2 Inhibitor, in Patients With Advanced Polycythemia Vera Who Are Refractory or Intolerant to Hydroxyurea. *Cancer.* 120:513–20.
16. [Verstovsek S, Kantarjian H, Mesa RA et al (2010)] Safety and Efficacy of INCB018424, a JAK1 and JAK2 Inhibitor, in Myelofibrosis. *N Engl J Med*; 363:1117-27.
17. [Verstovsek S., Mesa R.A, Gotlib J, et al (2012)] A Double-Blind, Placebo-Controlled Trial of Ruxolitinib for Myelofibrosis. *N Engl J Med*; 366:799-807.

PART III: CONSUMER INFORMATION

Pr JAKAVI®

(ruxolitinib tablets)
(as ruxolitinib phosphate)

This leaflet is part III of a three-part "Product Monograph" published when JAKAVI was approved for sale in Canada and is designed specifically for Consumers. This leaflet is a summary and will not tell you everything about JAKAVI. Contact your healthcare professional (doctor, pharmacist or nurse) if you have any questions about the drug.

ABOUT THIS MEDICATION

What the medication is used for:

JAKAVI is a prescription drug used to treat adult patients with enlarged spleen and/or its associated symptoms caused by myelofibrosis, a rare form of blood cancer.

JAKAVI is also used to control the haematocrit (the amount of red blood cells in the blood) in adult patients with polycythemia vera who are unable to use or who do not have their hematocrit controlled with a cytoreductive agent.

JAKAVI should be prescribed and monitored by a physician experienced in the use of anti-cancer therapies.

What it does:

Myelofibrosis is a disorder of the bone marrow, in which the marrow is replaced by scar tissue. JAKAVI is a kinase inhibitor that works at reducing spleen size and/or its associated symptoms caused by myelofibrosis.

Polycythemia vera is a disorder of the bone marrow, in which the marrow produces too many red blood cells. This makes the blood thicker. JAKAVI is a kinase inhibitor that can reduce the amount of red blood cells in the blood in patients with polycythemia vera.

When it should not be used:

Do not take JAKAVI if you:

- are allergic (hypersensitive) to ruxolitinib, or any of the other ingredients of JAKAVI listed under "What the nonmedicinal ingredients are".
- have or have had a disease called progressive multifocal leukoencephalopathy (PML).

What the medicinal ingredient is:

Ruxolitinib phosphate.

What the nonmedicinal ingredients are:

microcrystalline cellulose, hydroxypropylcellulose, lactose monohydrate, magnesium stearate, colloidal silicon dioxide, sodium starch glycolate (Type A), povidone.

What dosage forms it comes in:

Tablets; 5 mg, 10 mg, 15 mg and 20 mg

WARNINGS AND PRECAUTIONS

Serious Warnings and Precautions

Serious infections have been reported in patients treated with JAKAVI. Some cases were life-threatening or lead to death.

BEFORE you use JAKAVI talk to your doctor or pharmacist if you:

- have any type of infections. It may be necessary to treat your infection before starting JAKAVI. It is important that you tell your doctor if you have ever had tuberculosis or if you have been in close contact with someone who has had or has tuberculosis. Your doctor may test you to see if you have tuberculosis.
- have any kidney problems.
- have or have ever had liver problems.
- have any heart problems, including low heart rate, or if you ever have fainting spells.
- have intolerance to lactose (milk sugar). JAKAVI contains lactose.
- are pregnant or plan to become pregnant. JAKAVI is not recommended during pregnancy. You must use an effective method of birth control to avoid becoming pregnant while taking JAKAVI.
- are breast-feeding. JAKAVI may harm your baby.
- are a male patient. You must take appropriate precautions to avoid fathering a child during JAKAVI treatment.
- have ever had skin cancer.
- have ever had viral hepatitis B (a liver disease).

Children and adolescents (under 18 years old)

The safety of JAKAVI in patients younger than 18 years old have not been established.

During your treatment with JAKAVI

Tell your doctor straight away:

- If you experience unexpected bruising and/or bleeding, unusual tiredness, shortness of breath with exercise or at rest, looking pale, or frequent infections (signs of blood disorders).

- If you experience fever, chills or any symptoms of infections or if you develop painful skin rash with blisters (signs of shingles).
- If you experience chronic cough with blood-tinged sputum, fever, night sweats, and weight loss (these are signs of tuberculosis).
- If you have any of the following symptoms or if anyone close to you notices that you have any of these symptoms: confusion or difficulty thinking, loss of balance or difficulty walking, clumsiness, difficulty speaking, decreased strength or weakness on one side of your body, blurred and/or loss of vision (these are signs of progressive multifocal leukoencephalopathy).
- If you notice any skin changes. This may require further observation, as certain types of skin cancer (non-melanoma) have been reported with the use of JAKAVI. You should minimize your exposure to sunlight and other sources of UV light, such as tanning beds, while taking JAKAVI.
- If you have fever, cough, difficult or painful breathing, wheezing, pain in chest when breathing (possible symptoms of pneumonia).

INTERACTIONS WITH THIS MEDICATION

As with most medicines, interactions with other drugs are possible. Tell your doctor or pharmacist about all the medicines you take, including drugs prescribed by other doctors, vitamins, minerals, natural supplements, or alternative medicines.

It is particularly important that you mention any of the following medicines:

- some medicines used to treat infections. These include medicines which treat fungal diseases (antifungals like fluconazole, ketoconazole, itraconazole, posaconazole and voriconazole, or medicines to treat types of bacterial infections (antibiotics like clarithromycin, or telithromycin), or medicines to treat viral infections, including HIV/AIDS (atazanavir, indinavir, nelfinavir, ritonavir, saquinavir).
- Any medications that you are taking that affect the heart or blood pressure, such as antiarrhythmics, digitalis glycosides, antihypertensives and cimetidine (a medicine to treat heartburn).

While you are taking JAKAVI you should never start a new medicine without checking first with the doctor who has prescribed you JAKAVI. This includes prescribed medicines, over the counter medicines and herbal or alternative medicines.

PROPER USE OF THIS MEDICATION

Follow your doctor's instructions carefully. Do not take more JAKAVI than what your doctor told you.

Usual adult dose:

Patients with Myelofibrosis: 15 mg or 20 mg by mouth twice daily

Patients with Polycythemia vera: 10 mg by mouth twice daily

The maximum dose is 25 mg twice daily.

It is important to take JAKAVI at about the same time every day. If you require hemodialysis, you only need to take a single dose of JAKAVI after each hemodialysis session.

JAKAVI can be taken either with or without food. **Swallow whole** with a glass of water. Do NOT cut, break, dissolve, crush or chew the tablet.

How long to take JAKAVI

You should continue taking JAKAVI for as long as your doctor tells you to. This is a long-term treatment. Your doctor will regularly monitor your condition to make sure that the treatment is having the desired effect.

If you have questions about how long to take JAKAVI, talk to your doctor or pharmacist.

Monitoring during your treatment with JAKAVI

Before you start treatment with JAKAVI, your doctor will perform blood tests to determine the starting dose for you. Your doctor will carefully check if you have any signs or symptoms of infection before starting and during your treatment with JAKAVI.

You will have some blood tests during your treatment with JAKAVI to monitor the amount of blood cells in your body (white and red blood cells, platelets), and your kidney and liver functions. These tests are performed to see how you respond to the treatment, or to see if JAKAVI is having an unwanted effect. Your doctor may need to adjust the dose of JAKAVI or interrupt your treatment with JAKAVI. You will also have other tests during your treatment with JAKAVI to monitor the condition of your heart beat and blood pressure. Your doctor may also regularly check the level of lipids (fat) in your blood.

Overdose:

If you take more JAKAVI than you should or in case of drug overdose, contact a health care practitioner, hospital emergency department or regional Poison Control Centre immediately, even if there are no symptoms.

Missed Dose:

Do not use a double dose of JAKAVI to make up for a forgotten dose. If you forgot to take JAKAVI simply take your next dose at the scheduled time.

If you stop taking JAKAVI

If you are taking JAKAVI to treat myelofibrosis and you interrupt your treatment, your myelofibrosis related symptoms may come back. Therefore, you should not stop taking JAKAVI while being treated for myelofibrosis without checking first with your doctor.

If you have any further questions on the use of this product, ask your doctor or pharmacist.

SIDE EFFECTS AND WHAT TO DO ABOUT THEM

Side effects may include:

- High level of cholesterol (hypercholesterolemia) or fat (hypertriglyceridemia) in the blood
- Dizziness
- Headache
- Abnormal liver function test results
- Weight gain
- Frequently passing gas (flatulence), diarrhea, nausea
- Muscle spasms
- Ringing in the ears
- Back pain
- Numbness
- Anxiety
- Cough, pain in the mouth and/or throat
- Nose bleeds
- Constipation
- High blood pressure (hypertension) may also be the cause of dizziness and headache

If any of these affects you severely, tell your doctor or pharmacist.

SERIOUS SIDE EFFECTS, HOW OFTEN THEY HAPPEN AND WHAT TO DO ABOUT THEM

Symptom / effect	Talk with your doctor or pharmacist		Stop taking drug and call your doctor or pharmacist
	Only if severe	In all cases	
Very Common			
-Urinary tract infection: Symptoms like frequent urination, painful urination, blood in the urine		√	
-Tiredness, fatigue, shortness of breath, pale skin (symptoms of anemia which is caused by low level of red blood cells)		√	
-Frequent infections, fever, chills, sore throat or mouth ulcers due to infections (symptoms of neutropenia which is caused by low level of white blood cells)		√	
-Spontaneous bleeding or bruising (symptoms of thrombocytopenia which is caused by low levels of platelets)		√	
Common			
- Painful skin rash with blisters (symptoms of shingles)		√	
-Any sign of bleeding in the brain, such as sudden altered level of consciousness, persistent headache, numbness, tingling, weakness or paralysis			√
-Any sign of bleeding in the stomach or intestine, such as passing black or bloodstained stools, or vomiting blood.			√
- Any sign of heart problems such as low heart beat, chest pain, dizziness, vertigo, fainting			√
- Palpitation		√	
Uncommon			
-Chronic cough with blood-tinged sputum, fever, night sweats, and weight loss (symptoms of tuberculosis)			√
Unknown frequency			

SERIOUS SIDE EFFECTS, HOW OFTEN THEY HAPPEN AND WHAT TO DO ABOUT THEM

Symptom / effect	Talk with your doctor or pharmacist		Stop taking drug and call your doctor or pharmacist
	Only if severe	In all cases	
Confusion or difficulty thinking, loss of balance or difficulty walking, clumsiness, difficulty speaking, decreased strength or weakness on one side of your body, blurred and/or loss of vision (symptoms of progressive multifocal leukoencephalopathy).			√

<http://www.novartis.ca>

or by contacting the sponsor
Novartis Pharmaceuticals Canada Inc., at:
1-800-363-8883

This leaflet was prepared by
Novartis Pharmaceuticals Canada Inc.
385, Bouchard Blvd.
Dorval, Quebec, H9S 1A9

Last revised: September 28, 2018

PrJAKAVI® (ruxolitinib) is a registered trademark.

This is not a complete list of side effects. For any unexpected effects while taking JAKAVI contact your doctor or pharmacist.

HOW TO STORE IT

- Do not take JAKAVI after the expiry date shown on the box.
- Store between 15-25 °C.
- Store in the original package.
- Keep out of the reach and sight of children.

Disposal of unused medicines should follow local rules and requirements.

REPORTING SUSPECTED SIDE EFFECTS

You can help improve the safe use of health products for Canadians by reporting serious and unexpected side effects to Health Canada. Your report may help to identify new side effects and change the product safety information.

3 ways to report:

- Online at MedEffect;(www.healthcanada.gc.ca/medeffect)
- By calling 1-866-234-2345 (toll-free);
- By completing a Consumer Side Effect Reporting Form and sending it by:
 - Fax to 1-866-678-6789 (toll-free), or
 - Mail to: Canada Vigilance Program
Health Canada, Postal Locator 1908C
Ottawa, ON
K1A 0K9

Postage paid labels and the Consumer Side Effect Reporting Form are available at MedEffect.

NOTE: Contact your healthcare professional if you need information about how to manage your side effects. The Canada Vigilance Program does not provide medical advice.

MORE INFORMATION

This document plus the full product monograph, prepared for health professionals can be found at:

PRODUCT MONOGRAPH

JANUMET®

sitagliptin and metformin hydrochloride tablets

50 mg/500 mg, 50 mg/850 mg and 50 mg/1000 mg
sitagliptin (as sitagliptin phosphate monohydrate)/metformin hydrochloride, tablets, oral

JANUMET® XR

sitagliptin and metformin hydrochloride modified-release tablets

50 mg/500 mg, 50 mg/1000 mg, and 100 mg/1000 mg
sitagliptin (as sitagliptin phosphate monohydrate)/metformin hydrochloride, tablets, oral

ATC Code: A10BD07

Combinations of oral blood glucose lowering drugs

Merck Canada Inc.
16750 route Transcanadienne
Kirkland, QC Canada H9H 4M7
www.merck.ca

Date of Preparation:
November 26, 2019

Date of Revision:
December 18, 2019

Submission Control No: 230913

Table of Contents

PART I: HEALTH PROFESSIONAL INFORMATION.....	3
SUMMARY PRODUCT INFORMATION	3
INDICATIONS AND CLINICAL USE	3
CONTRAINDICATIONS	4
WARNINGS AND PRECAUTIONS.....	5
ADVERSE REACTIONS.....	13
DRUG INTERACTIONS	25
DOSAGE AND ADMINISTRATION	29
OVERDOSAGE	32
ACTION AND CLINICAL PHARMACOLOGY	32
STORAGE AND STABILITY	40
DOSAGE FORMS, COMPOSITION AND PACKAGING	40
PART II : SCIENTIFIC INFORMATION	42
PHARMACEUTICAL INFORMATION.....	42
CLINICAL TRIALS.....	43
DETAILED PHARMACOLOGY	50
TOXICOLOGY	52
REFERENCES	56
PART III: CONSUMER INFORMATION.....	57

JANUMET®

sitagliptin and metformin hydrochloride tablets
(as sitagliptin phosphate monohydrate and metformin hydrochloride)

JANUMET® XR

sitagliptin and metformin hydrochloride modified-release tablets
(as sitagliptin phosphate monohydrate and metformin hydrochloride)

PART I: HEALTH PROFESSIONAL INFORMATION

SUMMARY PRODUCT INFORMATION

Route of Administration	Dosage Form / Strength	Clinically Relevant Non-medicinal Ingredients
Oral	Tablets: sitagliptin (as sitagliptin phosphate monohydrate) / metformin hydrochloride 50 mg/500 mg, 50 mg/850 mg, and 50 mg/1000 mg Modified-release Tablets: immediate release sitagliptin (as sitagliptin phosphate monohydrate) / extended-release metformin hydrochloride 50 mg/500 mg, 50 mg/1000 mg, and 100 mg/1000 mg	<i>For a complete listing see DOSAGE FORMS, COMPOSITION AND PACKAGING section.</i>

INDICATIONS AND CLINICAL USE

JANUMET® (sitagliptin/metformin hydrochloride) and JANUMET® XR (sitagliptin/metformin hydrochloride modified-release) are indicated as an adjunct to diet and exercise to improve glycemic control in adult patients with type 2 diabetes mellitus inadequately controlled on metformin or in patients already being treated with the combination of sitagliptin and metformin.

JANUMET® and JANUMET® XR are indicated in combination with a sulfonylurea (i.e., triple combination therapy) as an adjunct to diet and exercise to improve glycemic control in adult patients with type 2 diabetes mellitus inadequately controlled on metformin and a sulfonylurea.

JANUMET[®] and JANUMET[®] XR are indicated in combination with premixed or long/intermediate acting insulin as an adjunct to diet and exercise to improve glycemic control in adult patients with type 2 diabetes mellitus inadequately controlled on metformin, and premixed or long/intermediate acting insulin.

JANUMET[®] and JANUMET[®] XR are indicated in combination with pioglitazone in adult patients with type 2 diabetes mellitus to improve glycemic control when diet and exercise, and dual therapy with metformin and pioglitazone do not provide adequate glycemic control.

See [CLINICAL TRIALS](#) section.

Geriatrics (≥65 years of age): JANUMET[®] and JANUMET[®] XR should be used with caution in geriatric patients. Sitagliptin and metformin are substantially excreted by the kidney. Because aging can be associated with reduced renal function, care should be taken in dose selection and should be based on careful and regular monitoring of renal function (see [WARNINGS AND PRECAUTIONS, Endocrine and Metabolism](#), and [Special Populations](#)).

Pediatrics (<18 years of age): Safety and effectiveness of JANUMET[®] and JANUMET[®] XR in pediatric patients have not been established. Therefore, JANUMET[®] and JANUMET[®] XR should not be used in this population.

CONTRAINDICATIONS

- Unstable and/or insulin-dependent (type 1) diabetes mellitus.
- Acute or chronic metabolic acidosis, including diabetic ketoacidosis, with or without coma, history of ketoacidosis with or without coma.
- In patients with a history of lactic acidosis, irrespective of precipitating factors (see [WARNINGS AND PRECAUTIONS](#)).
- In the presence of severe renal impairment [estimated glomerular filtration rate (eGFR) <30 mL/min/1.73 m²], end-stage renal disease, in patients on dialysis or when renal function is not known (see [WARNINGS AND PRECAUTIONS](#)).
- In excessive alcohol intake, acute or chronic.
- In patients suffering from severe hepatic dysfunction, since severe hepatic dysfunction has been associated with some cases of lactic acidosis, JANUMET[®] and JANUMET[®] XR should not be used in patients with clinical or laboratory evidence of hepatic disease.
- In cases of cardiovascular collapse and in disease states associated with hypoxemia such as cardiorespiratory insufficiency, which are often associated with hyperlactacidemia.
- During stress conditions, such as severe infections, trauma or surgery and the recovery phase thereafter.
- In patients suffering from severe dehydration or shock.
- Known hypersensitivity to sitagliptin, metformin or to any ingredient in the formulation, including any non-medicinal ingredient, or component of the container (see [WARNINGS AND PRECAUTIONS](#) and [ADVERSE REACTIONS](#)). For a complete listing, see the [DOSAGE FORMS, COMPOSITION AND PACKAGING](#) section.
- During pregnancy and breastfeeding (see [WARNINGS AND PRECAUTIONS, Special populations](#)).

- During period around administration of iodinated contrast materials, because the use of such products may result in acute alteration of renal function (see [WARNINGS AND PRECAUTIONS](#)).

WARNINGS AND PRECAUTIONS

Serious Warnings and Precautions

Lactic Acidosis

- Lactic acidosis is a rare, but serious, metabolic complication that can occur due to metformin accumulation during treatment with JANUMET[®] or JANUMET[®] XR (see [WARNINGS AND PRECAUTIONS, Endocrine and Metabolism – Lactic Acidosis](#)).
- Patients should be cautioned against excessive alcohol intake, either acute or chronic, when taking JANUMET[®] or JANUMET[®] XR, since alcohol intake potentiates the effect of metformin on lactate metabolism (see [WARNINGS AND PRECAUTIONS, Endocrine and Metabolism – Lactic Acidosis](#)).

General

JANUMET[®] and JANUMET[®] XR should not be used in patients with type 1 diabetes or for the treatment of diabetic ketoacidosis.

Cardiovascular

Hypoxic States:

Metformin hydrochloride

Cardiovascular collapse (shock) from whatever cause (e.g., acute congestive heart failure, acute myocardial infarction and other conditions characterized by hypoxemia) have been associated with lactic acidosis and may also cause prerenal azotemia (see [WARNINGS AND PRECAUTIONS, Endocrine and Metabolism](#)). When such events occur in patients on JANUMET[®] or JANUMET[®] XR therapy, the drug should be promptly discontinued.

Endocrine and Metabolism

Hypoglycemia:

Sitagliptin

When sitagliptin and metformin were used in combination with a sulfonylurea or in combination with insulin, the incidence of hypoglycemia was increased over that of placebo and metformin used in combination with a sulfonylurea or in combination with insulin (see [ADVERSE REACTIONS](#)). To reduce the risk of hypoglycemia associated with these regimens, a lower dose of sulfonylurea or insulin may be considered (see [DOSAGE AND ADMINISTRATION](#)).

Metformin hydrochloride

Hypoglycemia does not occur in patients receiving metformin alone under usual circumstances of use, but could occur when caloric intake is deficient, when strenuous exercise is not compensated by caloric supplementation, or during concomitant use with other glucose-lowering agents (such as sulfonylureas and insulin) or ethanol. Elderly, debilitated, or malnourished patients and those with adrenal or pituitary insufficiency or alcohol intoxication are particularly

susceptible to hypoglycemic effects. Hypoglycemia may be difficult to recognize in the elderly, and in people who are taking β -adrenergic blocking drugs.

Hypothyroidism:

Metformin hydrochloride

Metformin induces a reduction in thyrotropin (thyroid stimulating hormone (TSH) levels in patients with treated or untreated hypothyroidism (see [ADVERSE REACTIONS](#)). Regular monitoring of TSH levels is recommended in patients with hypothyroidism (see [WARNINGS AND PRECAUTIONS, Monitoring and Laboratory Tests](#)).

Studies have shown that metformin reduces plasma TSH levels, often to subnormal levels, when it is administered to patients with untreated hypothyroidism or to hypothyroid patients effectively treated with Levothyroxine. The metformin-induced reduction of plasma TSH levels is not observed when metformin is administered to patients with normal thyroid function. Metformin has been suggested to enhance the inhibitory modulation of thyroid hormones on TSH secretion.

Levothyroxine can reduce the hypoglycemic effect of metformin. Careful monitoring of blood glucose levels is recommended in patients with hypothyroidism treated with levothyroxine, especially when thyroid hormone therapy is initiated, changed, or stopped (see [WARNINGS AND PRECAUTIONS, Monitoring and Laboratory Tests](#) and [DRUG INTERACTIONS](#)).

Lactic Acidosis:

Metformin hydrochloride

Lactic acidosis is a rare, but serious, metabolic complication that can occur due to metformin accumulation during treatment with JANUMET[®] or JANUMET[®] XR; when it occurs, it is fatal in approximately 50% of cases. Lactic acidosis may also occur in association with a number of pathophysiologic conditions, including diabetes mellitus, and whenever there is significant tissue hypoperfusion and hypoxemia. Lactic acidosis is characterized by elevated blood lactate levels (>5 mmol/L), decreased blood pH, electrolyte disturbances with an increased anion gap, and an increased lactate/pyruvate ratio. When metformin is implicated as the cause of lactic acidosis, metformin plasma levels >5 μ g/mL are generally found.

The reported incidence of lactic acidosis in patients receiving metformin hydrochloride is very low (approximately 0.03 cases/1000 patient-years, with approximately 0.015 fatal cases/1000 patient-years). Reported cases have occurred primarily in diabetic patients with significant renal impairment, including both intrinsic renal disease and renal hypoperfusion, often in the setting of multiple concomitant medical/surgical problems and multiple concomitant medications (see [DOSAGE AND ADMINISTRATION](#)).

Patients with congestive heart failure requiring pharmacologic management, in particular those with unstable or acute congestive heart failure who are at risk of hypoperfusion and hypoxemia, are at increased risk of lactic acidosis. In particular, treatment of the elderly should be accompanied by careful monitoring of renal function. The risk of lactic acidosis increases with the degree of renal dysfunction and the patient's age (see [WARNINGS AND PRECAUTIONS, Special Populations](#)). The risk of lactic acidosis may, therefore, be significantly decreased by regular monitoring of renal function in patients taking metformin and by use of the minimum effective dose of metformin.

In addition, JANUMET[®] or JANUMET[®] XR should be promptly withheld in the presence of any condition associated with hypoxemia, dehydration, or sepsis. Because impaired hepatic function may significantly limit the ability to clear lactate, metformin should generally be avoided in patients with clinical or laboratory evidence of hepatic disease.

Patients should be cautioned against excessive alcohol intake, either acute or chronic, when taking JANUMET[®] or JANUMET[®] XR, since alcohol potentiates the effects of metformin hydrochloride on lactate metabolism. In addition, JANUMET[®] or JANUMET[®] XR should be temporarily discontinued prior to any intravascular radiocontrast study and for any surgical procedure.

The onset of lactic acidosis often is subtle, and accompanied only by nonspecific symptoms such as malaise, myalgia, respiratory distress, increasing somnolence, and nonspecific abdominal distress. There may be associated hypothermia, hypotension, and resistant bradyarrhythmias with more marked acidosis. The patient and the patient's physician must be aware of the possible importance of such symptoms and the patient should be instructed to notify the physician immediately if they occur. JANUMET[®] or JANUMET[®] XR should be withdrawn until the situation is clarified. Serum electrolytes, ketones, blood glucose, and if indicated, blood pH, lactate levels, and even blood metformin levels may be useful. Once a patient is stabilized on any dose level of metformin, gastrointestinal symptoms, which are common during initiation of therapy, are unlikely to be drug related. Later occurrence of gastrointestinal symptoms could be due to lactic acidosis or other serious disease.

Levels of fasting venous plasma lactate above the upper limit of normal but less than 5 mmol/L in patients taking metformin do not necessarily indicate impending lactic acidosis and may be explainable by other mechanisms, such as poorly controlled diabetes or obesity, vigorous physical activity, or technical problems in sample handling.

Lactic acidosis should be suspected in any diabetic patient with metabolic acidosis lacking evidence of ketoacidosis (ketonuria and ketonemia).

Lactic acidosis is a medical emergency that must be treated in a hospital setting. In a patient with lactic acidosis who is taking JANUMET[®] or JANUMET[®] XR, the drug should be discontinued immediately and general supportive measures promptly instituted. Because metformin hydrochloride is dialyzable (with a clearance of up to 170 mL/min under good hemodynamic conditions), prompt hemodialysis is recommended to correct the acidosis and remove the accumulated metformin (see [CONTRAINDICATIONS](#) and [WARNINGS AND PRECAUTIONS, Cardiovascular, Hepatic/Biliary/Pancreatic](#) and [Renal](#)).

Physicians should instruct their patients to recognize the symptoms which could be a signal of the onset of lactic acidosis. If acidosis of any kind develops, JANUMET[®] or JANUMET[®] XR should be discontinued immediately and the patient should be immediately hospitalized.

Change in Clinical Status of Previously Controlled Diabetes Patients:

Metformin hydrochloride

A diabetic patient previously well controlled on JANUMET[®] or JANUMET[®] XR who develops laboratory abnormalities or clinical illness (especially vague and poorly defined illness) should be evaluated promptly for evidence of ketoacidosis or lactic acidosis. Evaluation should include

serum electrolytes and ketones, blood glucose and, if indicated, blood pH, lactate, pyruvate and metformin levels. If acidosis of either form occurs, JANUMET[®] or JANUMET[®] XR must be stopped immediately and appropriate corrective measures initiated.

Loss of Control of Blood Glucose:

The effectiveness of oral antidiabetic drugs in lowering blood glucose to a targeted level decreases in many patients over a period of time. This phenomenon, which may be due to progression of the underlying disease or to diminished responsiveness to the drug, is known as secondary failure, to distinguish it from primary failure in which the drug is ineffective during initial therapy. Should secondary failure occur with JANUMET[®] or JANUMET[®] XR, therapeutic alternatives should be considered.

Metformin hydrochloride

When a patient stabilized on any diabetic regimen is exposed to stress such as fever, trauma, infection, or surgery, a temporary loss of glycemic control may occur. At such times, it may be necessary to withhold JANUMET[®] or JANUMET[®] XR and temporarily administer insulin. JANUMET[®] or JANUMET[®] XR may be reinstated after the acute episode is resolved.

Vitamin B₁₂ Levels:

Metformin hydrochloride

Impairment of vitamin B₁₂ absorption has been reported in some patients treated with metformin. Therefore, measurements of serum vitamin B₁₂ are advisable at least every one to two years in patients on long-term treatment with JANUMET[®] or JANUMET[®] XR.

A decrease to subnormal levels of previously normal serum vitamin B₁₂ levels, without clinical manifestations, is observed in approximately 7% of patients receiving metformin in controlled clinical trials of 28 weeks duration. Such decrease, possibly due to interference with B₁₂ absorption from the B₁₂-intrinsic factor complex, is, however, very rarely associated with anemia and appears to be rapidly reversible with discontinuation of metformin or vitamin B₁₂ supplementation. Measurement of hematologic parameters on an annual basis is advised in patients on JANUMET[®] or JANUMET[®] XR and any apparent abnormalities should be appropriately investigated and managed (see [WARNINGS AND PRECAUTIONS, Monitoring and Laboratory Tests](#)). Certain individuals (those with inadequate vitamin B₁₂ or calcium intake or absorption) appear to be predisposed to developing subnormal vitamin B₁₂ levels.

Long-term treatment with metformin has been associated with a decrease in serum vitamin B₁₂ levels which may cause peripheral neuropathy. Serious cases of peripheral neuropathy have been reported with metformin treatment, one of the components of JANUMET[®] and JANUMET[®] XR, in the context of vitamin B₁₂ deficiency (see [ADVERSE REACTIONS](#)). Monitoring of serum vitamin B₁₂ levels is recommended (see [WARNINGS AND PRECAUTIONS, Monitoring and Laboratory Tests](#)).

Hematologic

Metformin hydrochloride

Serious cases of metformin-induced hemolytic anemia, some with fatal outcome, have been reported (see [ADVERSE REACTIONS](#)). Two mechanisms were described for the metformin-induced immune hemolytic anemia; formation of an antibody against the erythrocyte-metformin

complex and autoantibody formation. Monitoring of hematologic parameters is recommended (see [WARNINGS AND PRECAUTIONS, Monitoring and Laboratory Tests](#)).

Hepatic/Biliary/Pancreatic

Hepatic: JANUMET[®] or JANUMET[®] XR is contraindicated in patients with severe hepatic dysfunction and should not be used in patients with clinical or laboratory evidence of hepatic disease (see [CONTRAINDICATIONS](#)).

Sitagliptin

There are limited clinical experiences in patients with moderate hepatic impairment and no clinical experience in patients with severe hepatic impairment. Use in patients with severe hepatic impairment is not recommended (see [ACTION AND CLINICAL PHARMACOLOGY](#)).

Metformin hydrochloride

Impaired hepatic function has been associated with some cases of lactic acidosis.

Pancreatitis:

Sitagliptin

There have been reports of acute pancreatitis, including fatal and non-fatal hemorrhagic or necrotizing pancreatitis, in patients taking sitagliptin, one of the components of JANUMET[®] and JANUMET[®] XR. In a long-term cardiovascular outcomes trial (see [ADVERSE REACTIONS](#) and [CLINICAL TRIALS](#)), there were two adjudication-confirmed deaths due to acute pancreatitis in sitagliptin patients compared to none in the placebo group. After initiation of JANUMET[®] or JANUMET[®] XR, patients should be observed carefully for signs and symptoms of pancreatitis. If pancreatitis is suspected, JANUMET[®] or JANUMET[®] XR should promptly be discontinued and appropriate management should be initiated. Risk factors for pancreatitis include a history of: pancreatitis, gallstones, alcoholism, or hypertriglyceridemia.

Metformin hydrochloride

Serious cases of pancreatitis have been reported in patients receiving metformin (see [ADVERSE REACTIONS](#)). The reported pancreatitis cases occurred either in the context of an acute metformin overdose (see [OVERDOSAGE](#)) or in patients receiving therapeutic doses of metformin with concurrent renal failure and/or lactic acidosis, indicating metformin accumulation.

Immune

Hypersensitivity Reactions:

Sitagliptin

There have been post-marketing reports of serious hypersensitivity reactions in patients treated with sitagliptin, one of the components of JANUMET[®] and JANUMET[®] XR. These reactions include anaphylaxis, angioedema, and exfoliative skin conditions including Stevens-Johnson syndrome. Onset of these reactions occurred within the first 3 months after initiation of treatment with sitagliptin, with some reports occurring after the first dose. If a hypersensitivity reaction is suspected, discontinue JANUMET[®] or JANUMET[®] XR, assess for other potential causes for the event, and institute alternative treatment for diabetes (see [CONTRAINDICATIONS](#) and [ADVERSE REACTIONS](#)).

Immunocompromised Patients:

Sitagliptin

A dose-related mean decrease in absolute lymphocyte count was observed with other dipeptidyl peptidase 4 (DPP-4) inhibitors. When clinically indicated, such as in settings of unusual or prolonged infection, lymphocyte count should be measured. The effect of sitagliptin, a component of JANUMET[®] and JANUMET[®] XR, on lymphocyte counts in patients with lymphocyte abnormalities (e.g. human immunodeficiency virus) is unknown.

Immunocompromised patients, such as patients who have undergone organ transplantation or patients diagnosed with human immunodeficiency syndrome have not been studied in the sitagliptin clinical program. Therefore, the efficacy and safety profile of sitagliptin in these patients has not been established.

Monitoring and Laboratory Tests

Blood Glucose and HbA_{1c}: Response to JANUMET[®] and JANUMET[®] XR treatment should be monitored by periodic measurements of blood glucose and HbA_{1c} levels.

Hematology: Initial and periodic monitoring of hematologic parameters (e.g., hemoglobin/hematocrit and red blood cell indices) should be performed, regularly. While megaloblastic anemia has rarely been seen with metformin therapy, if this is suspected, vitamin B₁₂ deficiency should be excluded. Periodic measurements of serum vitamin B₁₂ levels should be performed in patients on long-term treatment with JANUMET[®] and JANUMET[®] XR, especially in patients with anemia or neuropathy (see [WARNINGS AND PRECAUTIONS, Endocrine and Metabolism](#)).

A close monitoring of the International Normalized Ratio (INR) is recommended in patients concurrently administering metformin and phenprocoumon or other antivitamin K anticoagulants (see [DRUG INTERACTIONS](#)).

Hypothyroidism: Regular monitoring of thyroid-stimulating hormone (TSH) levels is recommended in patients with hypothyroidism.

For hypothyroid patients treated with levothyroxine, careful monitoring of blood glucose levels is recommended, especially when thyroid hormone therapy is initiated, changed, or stopped (see [WARNINGS AND PRECAUTIONS, Endocrine and Metabolism](#), and [DRUG INTERACTIONS](#)).

Renal Function: JANUMET[®] and JANUMET[®] XR are contraindicated in patients with an estimated glomerular rate (eGFR) <30 mL/min/1.73 m² (see [CONTRAINDICATIONS](#)). Renal function must be assessed prior to initiation of JANUMET[®] or JANUMET[®] XR and periodically thereafter, with more frequent monitoring in patients whose eGFR decreases to less than 60 mL/min/1.73 m² (see [DOSAGE AND ADMINISTRATION](#)).

Monitoring of renal function is recommended prior to and following initiation of any concomitant drug which might have an impact on renal function (see [DRUG INTERACTIONS](#)).

Neurologic

Metformin hydrochloride

Serious cases of metformin-induced encephalopathy have been reported (see [ADVERSE REACTIONS](#)). Some of these cases were reported without association with lactic acidosis, hypoglycemia, or renal impairment.

Peri-Operative Consideration

Metformin hydrochloride

JANUMET[®] or JANUMET[®] XR therapy should be temporarily suspended for any surgical procedure (except minor procedures not associated with restricted intake of food and fluids). JANUMET[®] or JANUMET[®] XR should be discontinued 2 days before surgical intervention and should not be restarted until the patient's oral intake has resumed and renal function has been evaluated as acceptable and found to be stable (see [DOSAGE AND ADMINISTRATION](#)).

Renal

JANUMET[®] and JANUMET[®] XR are contraindicated in patients with severe renal impairment (eGFR <30 mL/min/1.73 m²) (see [CONTRAINDICATIONS](#)).

Before initiation of JANUMET[®] or JANUMET[®] XR therapy and regularly thereafter, renal function must be assessed. In patients with eGFR less than 60 mL/min/1.73m², more intensive monitoring for glycemic and renal biomarkers and signs and symptoms of renal dysfunction is recommended, especially if the eGFR is less than 45 mL/min/1.73 m² (see [WARNINGS AND PRECAUTIONS, Monitoring and Laboratory Tests](#) and [DOSAGE AND ADMINISTRATION](#)).

In patients in whom development of renal dysfunction is anticipated, renal function should be assessed more frequently and JANUMET[®] or JANUMET[®] XR discontinued if evidence of renal impairment is present.

Special caution should be exercised in situations where renal function may become impaired, for example in the elderly, in the case of dehydration when initiating antihypertensive therapy or diuretic therapy or when starting therapy with a non-steroidal anti-inflammatory drug (NSAID). Therefore, consider more frequent monitoring of patients.

Sitagliptin

Sitagliptin is renally excreted. Renal adverse events, including acute renal failure, have been observed during clinical trials and post-marketing use of sitagliptin, a component of JANUMET[®] and JANUMET[®] XR, in patients with and without known risk factors (see [ADVERSE REACTIONS](#)).

Metformin hydrochloride

Metformin is known to be substantially excreted by the kidney, and the risk of metformin accumulation and lactic acidosis increases with the degree of impairment of renal function.

Use of concomitant medications that may affect renal function or metformin disposition:

Concomitant medication(s) that may affect renal function or result in significant hemodynamic change or may interfere with the disposition of metformin, such as cationic drugs, that are eliminated by renal tubular secretion (see [DRUG INTERACTIONS](#)) should be used with caution. The concomitant use of JANUMET[®] or JANUMET[®] XR with these specific drugs may

increase the risk of metformin-associated lactic acidosis and therefore, consider more frequent monitoring of patients.

Radiologic studies involving the use of intravascular iodinated contrast materials (for example, intravenous urogram, intravenous cholangiography, angiography, and computed tomography (CT) scans with intravascular contrast materials): Intravascular contrast studies with iodinated materials can lead to acute alteration of renal function and have been associated with lactic acidosis in patients receiving metformin (see [CONTRAINDICATIONS](#)). Therefore, in patients with an eGFR ≥ 30 to < 60 mL/min/1.73 m², in patients with a history of hepatic impairment, alcoholism, or heart failure, or in patients who will be administered intra-arterial iodinated contrast, JANUMET[®] or JANUMET[®] XR should be discontinued at the time of or prior to the procedure, and withheld for 48 hours subsequent to the procedure and reinstated only after renal function has been re-evaluated and found to be acceptable and stable (see [DOSAGE AND ADMINISTRATION](#)).

Skin

Sitagliptin

With other members of this class, DPP-4 inhibitors, ulcerative and necrotic skin lesions have been reported in monkeys in non-clinical toxicology studies. There is limited experience in patients with diabetic skin complications with sitagliptin, a component of JANUMET[®] and JANUMET[®] XR. In keeping with routine care of the diabetic patient, monitoring for skin disorders is recommended.

Bullous Pemphigoid: Post-marketing cases of bullous pemphigoid requiring hospitalization have been reported with the use of DPP-4 inhibitors, including sitagliptin, a component of JANUMET[®] and JANUMET[®] XR. In reported cases, patients typically recovered with topical or systemic immunosuppressive treatment and discontinuation of the DPP-4 inhibitor. Tell patients to report development of blisters or erosions while receiving JANUMET[®] or JANUMET[®] XR. If bullous pemphigoid is suspected, JANUMET[®] or JANUMET[®] XR should be discontinued and referral to a dermatologist should be considered for diagnosis and appropriate treatment.

Special Populations

Pregnant Women: JANUMET[®] and JANUMET[®] XR are contraindicated in pregnancy (see [CONTRAINDICATIONS](#)). There are no adequate and well-controlled studies in pregnant women with JANUMET[®] and JANUMET[®] XR or their individual components; therefore, the safety of JANUMET[®] and JANUMET[®] XR in pregnant women is not known. When pregnancy is detected, JANUMET[®] and JANUMET[®] XR should be discontinued.

Sitagliptin

There are very limited data for the use of sitagliptin in pregnant women in clinical studies, including no adequate and well-controlled studies in this population; therefore, the safety of sitagliptin in pregnant women is not known.

Metformin hydrochloride

Metformin was not teratogenic in rats and rabbits at doses up to 600 mg/kg/day, or about two and six times the maximum recommended human daily dose on a body surface area basis.

Determination of fetal concentrations demonstrated a partial placental barrier to metformin.

Because animal reproduction studies are not always predictive of human response, JANUMET[®] and JANUMET[®] XR are contraindicated during pregnancy (see [CONTRAINDICATIONS](#)).

Nursing Women: JANUMET[®] and JANUMET[®] XR are contraindicated during breast-feeding (see [CONTRAINDICATIONS](#)). No studies in lactating animals have been conducted with the combined components of JANUMET[®] and JANUMET[®] XR. Both sitagliptin and metformin are present in the milk of lactating rats. Metformin hydrochloride is also excreted into human breast milk in very small amounts but it is not known whether sitagliptin is secreted in human milk. Therefore, JANUMET[®] and JANUMET[®] XR should not be used by a woman during breastfeeding.

Pediatrics (<18 years of age): Safety and effectiveness of JANUMET[®] or JANUMET[®] XR in pediatric patients have not been established. Therefore, JANUMET[®] or JANUMET[®] XR should not be used in this population.

Geriatrics (≥65 years of age): Because sitagliptin and metformin are substantially excreted by the kidney and because aging can be associated with reduced renal function, JANUMET[®] or JANUMET[®] XR should be used with caution as age increases. Care should be taken in dose selection and should be based on careful and regular monitoring of renal function (see [WARNINGS AND PRECAUTIONS, Renal](#), and [DOSAGE AND ADMINISTRATION](#)).

Sitagliptin

In clinical studies, no overall differences in safety or effectiveness were observed between subjects 65 years and over and younger subjects. While this and other reported clinical experience have not identified differences in responses between the geriatric and younger patients, greater sensitivity of some older individuals cannot be ruled out. Renal function should be assessed prior to initiating dosing and periodically thereafter in geriatric patients (see [DOSAGE AND ADMINISTRATION](#) and [ACTION AND CLINICAL PHARMACOLOGY](#)).

Metformin hydrochloride

Controlled clinical studies of metformin did not include sufficient numbers of elderly patients to determine whether they respond differently from younger patients, although other reported clinical experience has not identified differences in responses between the elderly and younger patients. The risk of metformin-associated lactic acidosis increases with the patient's age because elderly patients have a greater likelihood of having hepatic, renal, or cardiac impairment than younger patients. Assess renal function more frequently in elderly patients.

ADVERSE REACTIONS

Adverse Drug Reaction Overview

Sitagliptin

Sitagliptin was generally well tolerated in controlled clinical studies as monotherapy and as part of a combination therapy with metformin or combination therapy with metformin and a sulfonyleurea or combination therapy with metformin, insulin and pioglitazone.

The incidences of serious adverse reactions and discontinuation of therapy due to clinical adverse reactions were generally similar to placebo. The most frequent adverse events in trials of sitagliptin as monotherapy (placebo-controlled) and as add-on combination therapy with

metformin (reported regardless of causality and more common with sitagliptin than other treatments) was nasopharyngitis. The most frequent adverse reaction with sitagliptin as add-on combination therapy with metformin and a sulfonylurea agent or with metformin and insulin was hypoglycemia.

Metformin hydrochloride

The adverse events most commonly associated with metformin (sitagliptin/metformin) are diarrhea, nausea, and upset stomach. Similar adverse reactions were seen in patients treated with modified-release metformin products. Lactic acidosis is a rare, but serious side effect. Lactic acidosis is fatal in approximately 50% of cases.

Lactic Acidosis: very rare (<1/10,000 and isolated reports) (see [WARNINGS AND PRECAUTIONS](#) and [OVERDOSAGE](#)).

Gastrointestinal Reactions: very common (>1/10): Gastrointestinal symptoms (diarrhea, nausea, vomiting, abdominal bloating, flatulence, and anorexia) are the most common reactions to metformin and are approximately 30% more frequent in patients on metformin monotherapy than in placebo-treated patients, particularly during initiation of metformin therapy. These symptoms are generally transient and resolve spontaneously during continued treatment. Occasionally, temporary dose reduction may be useful.

Because gastrointestinal symptoms during therapy initiation appear to be dose-related, they may be decreased by gradual dose escalation and by having patients take metformin (metformin hydrochloride) with meals (see [DOSAGE AND ADMINISTRATION](#)).

Because significant diarrhea and/or vomiting can cause dehydration and prerenal azotemia, metformin should be temporarily discontinued, under such circumstances.

For patients who have been stabilized on metformin, nonspecific gastrointestinal symptoms should not be attributed to therapy unless intercurrent illness or lactic acidosis have been excluded.

Special Senses: common ($\geq 1/100$): During initiation of metformin therapy complaints of taste disturbance are common, i.e. metallic taste.

Dermatologic Reactions: very rare (<1/10,000 and isolated reports): The incidence of rash/dermatitis in controlled clinical trials was comparable to placebo for metformin monotherapy and to sulfonylurea for metformin /sulfonylurea therapy. Reports of skin reactions such as erythema, pruritus, and urticaria are very rare.

Hematologic: Decrease of vitamin B₁₂ absorption with decrease of serum levels during long-term use of metformin is rare ($\geq 1/10,000$ and <1/1,000). Consideration of such etiology is recommended if a patient presents with megaloblastic anemia.

Hepatic: very rare (<1/10,000 and isolated reports): Liver function tests abnormalities or hepatitis resolving upon metformin discontinuation has been documented in isolated reports.

Clinical Trial Adverse Drug Reactions

Because clinical trials are conducted under very specific conditions the adverse reaction rates observed in the clinical trials may not reflect the rates observed in practice and should not be compared to the rates in the clinical trials of another drug. Adverse drug reaction information from clinical trials is useful for identifying drug-related adverse events and for approximating rates.

Combination Therapy – Sitagliptin Add-on to Metformin:

In a 24-week placebo-controlled clinical study of patients receiving sitagliptin (100 mg daily) as add-on combination therapy with metformin, the incidence of adverse events, reported regardless of causality assessment, in $\geq 1\%$ of patients are shown in Table 1.

Table 1 – Adverse Events $\geq 1\%$ in Any Treatment Group (regardless of causality) Reported in Patients in a 24-week Placebo-Controlled, Double-Blind Clinical Trial of Sitagliptin in Add-on Combination Use with Metformin

Body system/Organ class Adverse event	Number of patients (%)	
	Sitagliptin 100 mg + Metformin n=464	Placebo + Metformin n=237
Ear and labyrinth disorders		
Vertigo	5 (1.1)	4 (1.7)
Eye disorders		
Vision blurred	1 (0.2)	3 (1.3)
Gastrointestinal disorders		
Abdominal pain	2 (0.4)	6 (2.5)
Abdominal pain upper	6 (1.3)	2 (0.8)
Constipation	5 (1.1)	1 (0.4)
Diarrhea	11 (2.4)	6 (2.5)
Nausea	6 (1.3)	2 (0.8)
Vomiting	5 (1.1)	2 (0.8)
General disorders and administration site conditions		
Fatigue	2 (0.4)	4 (1.7)
Edema peripheral	4 (0.9)	3 (1.3)
Infections and infestations		
Bronchitis	12 (2.6)	6 (2.5)
Bronchitis acute	2 (0.4)	3 (1.3)
Gastroenteritis	4 (0.9)	5 (2.1)
Influenza	19 (4.1)	12 (5.1)
Nasopharyngitis	19 (4.1)	7 (3.0)
Pharyngitis	6 (1.3)	1 (0.4)
Pneumonia	5 (1.1)	0 (0.0)
Sinusitis	7 (1.5)	2 (0.8)
Tooth infection	5 (1.1)	2 (0.8)
Upper respiratory tract infection	34 (7.3)	22 (9.3)
Urinary tract infection	9 (1.9)	2 (0.8)
Injury, poisoning and procedural complications		
Contusion	5 (1.1)	1 (0.4)
Investigations		

Table 1 – Adverse Events $\geq 1\%$ in Any Treatment Group (regardless of causality) Reported in Patients in a 24-week Placebo-Controlled, Double-Blind Clinical Trial of Sitagliptin in Add-on Combination Use with Metformin

Body system/Organ class Adverse event	Number of patients (%)	
	Sitagliptin 100 mg + Metformin n=464	Placebo + Metformin n=237
Blood glucose increased	3 (0.6)	6 (2.5)
Metabolism and nutrition disorders		
Hyperglycemia	2 (0.4)	7 (3.0)
Hypoglycemia	6 (1.3)	5 (2.1)
Musculoskeletal and connective tissue disorders		
Arthralgia	14 (3.0)	1 (0.4)
Back pain	15 (3.2)	6 (2.5)
Muscle spasm	1 (0.2)	3 (1.3)
Myalgia	1 (0.2)	3 (1.3)
Pain in extremity	5 (1.1)	4 (1.7)
Shoulder pain	3 (0.6)	3 (1.3)
Nervous system disorders		
Dizziness	7 (1.5)	2 (0.8)
Headache	12 (2.6)	7 (3.0)
Sciatica	1 (0.2)	3 (1.3)
Sinus headache	0 (0.0)	3 (1.3)
Psychiatric disorders		
Insomnia	5 (1.1)	3 (1.3)
Renal and urinary disorders		
Nephrolithiasis	3 (0.6)	3 (1.3)
Respiratory, thoracic and mediastinal disorders		
Cough	14 (3.0)	4 (1.7)
Vascular disorders		
Hypertension	7 (1.5)	6 (2.5)

Nausea was the only drug-related adverse reaction reported by the investigator that occurred with an incidence $\geq 1\%$ in patients receiving sitagliptin (1.1%) and greater than in patients receiving placebo (0.4%).

In pooled studies of up to one year duration which compared sitagliptin added to metformin or a sulfonylurea agent (glipizide) added to metformin, adverse events, reported regardless of causality assessment, in $\geq 1\%$ of patients are shown in Table 2.

Table 2 – Adverse Events ≥1% in Any Treatment Group (regardless of causality) Reported in Patients from Double-Blind Clinical Trials of Sitagliptin in Add-on Combination Use with Metformin in Studies Up to One Year Compared to a Sulfonylurea Agent (Glipizide)

Body system/Organ class Adverse event	Number of patients (%)	
	Sitagliptin 100 mg + Metformin n=979	Glipizide + Metformin n=748
Gastrointestinal disorders		
Abdominal pain	10 (1.0)	6 (0.8)
Abdominal pain upper	13 (1.3)	7 (0.9)
Constipation	17 (1.7)	13 (1.7)
Diarrhea	42 (4.3)	36 (4.8)
Dyspepsia	14 (1.4)	12 (1.6)
Nausea	19 (1.9)	16 (2.1)
Toothache	2 (0.2)	13 (1.7)
Vomiting	11 (1.1)	9 (1.2)
General disorders and administration site conditions		
Fatigue	20 (2.0)	8 (1.1)
Non-cardiac chest pain	10 (1.0)	6 (0.8)
Edema peripheral	16 (1.6)	14 (1.9)
Infections and infestations		
Bronchitis	27 (2.8)	22 (2.9)
Cellulitis	7 (0.7)	10 (1.3)
Gastroenteritis	19 (1.9)	13 (1.7)
Gastroenteritis viral	8 (0.8)	9 (1.2)
Herpes zoster	4 (0.4)	8 (1.1)
Influenza	35 (3.6)	32 (4.3)
Nasopharyngitis	75 (7.7)	49 (6.6)
Sinusitis	20 (2.0)	12 (1.6)
Upper respiratory tract infection	78 (8.0)	70 (9.4)
Urinary tract infection	41 (4.2)	21 (2.8)
Investigations		
Blood glucose decreased	5 (0.5)	16 (2.1)
Blood glucose increased	13 (1.3)	5 (0.7)
Weight increased	1 (0.1)	8 (1.1)
Metabolism and nutrition disorders		
Hyperglycemia	10 (1.0)	6 (0.8)
Hypoglycemia	32 (3.3)	217 (29.0)
Musculoskeletal and connective tissue disorders		
Arthralgia	34 (3.5)	29 (3.9)
Back pain	39 (4.0)	32 (4.3)
Muscle spasms	9 (0.9)	8 (1.1)
Neck pain	4 (0.4)	8 (1.1)
Osteoarthritis	18 (1.8)	5 (0.7)
Pain in extremity	23 (2.3)	9 (1.2)
Shoulder pain	7 (0.7)	14 (1.9)
Nervous system disorders		
Dizziness	26 (2.7)	14 (1.9)
Headache	34 (3.5)	31 (4.1)
Hypoaesthesia	3 (0.3)	11 (1.5)
Psychiatric disorders		

Table 2 – Adverse Events $\geq 1\%$ in Any Treatment Group (regardless of causality) Reported in Patients from Double-Blind Clinical Trials of Sitagliptin in Add-on Combination Use with Metformin in Studies Up to One Year Compared to a Sulfonylurea Agent (Glipizide)

Body system/Organ class Adverse event	Number of patients (%)	
	Sitagliptin 100 mg + Metformin n=979	Glipizide + Metformin n=748
Anxiety	13 (1.3)	7 (0.9)
Depression	10 (1.0)	7 (0.9)
Insomnia	12 (1.2)	11 (1.5)
Reproductive system and breast disorders		
Erectile dysfunction	6 (0.6)	8 (1.1)
Respiratory, thoracic and mediastinal disorders		
Cough	19 (1.9)	23 (3.1)
Pharyngolaryngeal pain	10 (1.0)	9 (1.2)
Sinus congestion	5 (0.5)	8 (1.1)
Eczema	4 (0.4)	12 (1.6)
Vascular disorders		
Hypertension	33 (3.4)	29 (3.9)

Combination Therapy: Sitagliptin Add-on to Metformin and a Sulfonylurea

In a 24-week placebo-controlled study of sitagliptin 100 mg in combination with metformin and glimepiride (sitagliptin, N=116; placebo, N=113), the incidence of adverse events, reported regardless of causality assessment, in $\geq 1\%$ of patients are shown in Table 3. The overall incidence of adverse events with sitagliptin was higher than with placebo, in part related to higher incidence of hypoglycemia (see Table 3).

Table 3 – Adverse Events $\geq 1\%$ in Any Treatment Group (regardless of causality) Reported in Patients in a 24-Week Placebo-Controlled, Double-Blind Clinical Trial of Sitagliptin Add-on Combination Use with Metformin and a Sulfonylurea Agent (Glimepiride)

Body system/Organ class Adverse event	Number of patients (%)	
	Sitagliptin 100 mg + Metformin + Glimepiride n=116	Placebo + Metformin + Glimepiride n=113
Ear and Labyrinth Disorders		
Vertigo	2 (1.7)	0 (0.0)
Eye Disorders		
Diabetic retinopathy	0 (0.0)	2 (1.8)
Vision blurred	0 (0.0)	2 (1.8)
Gastrointestinal disorders		
Abdominal pain upper	2 (1.7)	2 (1.8)
Constipation	4 (3.4)	0 (0.0)
Diarrhea	1 (0.9)	4 (3.5)
Dyspepsia	3 (2.6)	2 (1.8)
Gastritis	0 (0.0)	4 (3.5)
Toothache	2 (1.7)	2 (1.8)
Vomiting	2 (1.7)	1 (0.9)
General disorders and administration site conditions		

Table 3 – Adverse Events ≥1% in Any Treatment Group (regardless of causality) Reported in Patients in a 24-Week Placebo-Controlled, Double-Blind Clinical Trial of Sitagliptin Add-on Combination Use with Metformin and a Sulfonylurea Agent (Glimepiride)

Body system/Organ class Adverse event	Number of patients (%)	
	Sitagliptin 100 mg + Metformin + Glimepiride n=116	Placebo + Metformin + Glimepiride n=113
Fatigue	0 (0.0)	3 (2.7)
Non-Cardiac chest pain	2 (1.7)	1 (0.9)
Pyrexia	0 (0.0)	2 (1.8)
Hepatobiliary disorders		
Cholelithiasis	0 (0.0)	2 (1.8)
Infections and infestations		
Bronchitis	2 (1.7)	2 (1.8)
Gastroenteritis	3 (2.6)	0 (0.0)
Gastroenteritis viral	2 (1.7)	2 (1.8)
Influenza	3 (2.6)	2 (1.8)
Nasopharyngitis	7 (6.0)	9 (8.0)
Pharyngitis	1 (0.9)	3 (2.7)
Pneumonia	3 (2.6)	0 (0.0)
Rhinitis	2 (1.7)	0 (0.0)
Sinusitis	1 (0.9)	2 (1.8)
Tooth abscess	2 (1.7)	1 (0.9)
Upper respiratory tract infection	8 (6.9)	9 (8.0)
Urinary tract infection	2 (1.7)	1 (0.9)
Injury, poisoning and procedural complications		
Fall	0 (0.0)	3 (2.7)
Polytraumatism	1 (0.9)	2 (1.8)
Investigations		
Blood glucose decreased	0 (0.0)	2 (1.8)
Metabolism and nutrition disorders		
Hypoglycemia	19 (16.4)	1 (0.9)
Musculoskeletal and connective tissue disorders		
Arthralgia	5 (4.3)	1 (0.9)
Back pain	1 (0.9)	2 (1.8)
Muscle spasms	2 (1.7)	1 (0.9)
Osteoarthritis	2 (1.7)	0 (0.0)
Pain in extremity	4 (3.4)	1 (0.9)
Shoulder pain	0 (0.0)	2 (1.8)
Nervous system disorders		
Dizziness	3 (2.6)	1 (0.9)
Headache	8 (6.9)	3 (2.7)
Hypoaesthesia	2 (1.7)	0 (0.0)
Somnolence	0 (0.0)	2 (1.8)
Respiratory, thoracic and mediastinal disorders		
Asthma	2 (1.7)	1 (0.9)
Skin and subcutaneous tissue disorders		
Pruritus	2 (1.7)	1 (0.9)

Table 3 – Adverse Events $\geq 1\%$ in Any Treatment Group (regardless of causality) Reported in Patients in a 24-Week Placebo-Controlled, Double-Blind Clinical Trial of Sitagliptin Add-on Combination Use with Metformin and a Sulfonylurea Agent (Glimepiride)

Body system/Organ class Adverse event	Number of patients (%)	
	Sitagliptin 100 mg + Metformin + Glimepiride n=116	Placebo + Metformin + Glimepiride n=113
Rash	2 (1.7)	1 (0.9)
Vascular disorders		
Hypertension	2 (1.7)	0 (0.0)

In a combination therapy study with metformin and a sulfonylurea, hypoglycemia (sitagliptin 13.8%; placebo 0.9%) and constipation (sitagliptin 1.7%; placebo 0.0%) were the only drug-related adverse reactions reported by the investigator that occurred with an incidence $\geq 1\%$ in patients receiving sitagliptin and metformin and a sulfonylurea and greater than in patients receiving placebo and metformin and a sulfonylurea.

Combination Therapy: Add-on to Metformin and Insulin

In a 24-week placebo-controlled study of sitagliptin 100 mg once daily added to ongoing combination treatment with metformin and insulin (sitagliptin, N=229; placebo, N=233), the only adverse experience reported regardless of causality assessment in $\geq 5\%$ of patients treated with sitagliptin and more commonly than in patients treated with placebo was hypoglycemia (sitagliptin 15.3%; placebo 8.2%).

Table 4 – Adverse Events $\geq 1\%$ in Any Treatment Group (regardless of causality) Reported in Patients in a 24-Week Placebo-Controlled, Double-Blind Clinical Trial of Sitagliptin in Add-on Combination Use with Metformin and Insulin

Body system/Organ class Adverse event	Number of patients (%)	
	Sitagliptin 100 mg + Metformin + Insulin n=229	Placebo + Metformin + Insulin n=233
Gastrointestinal Disorders		
Constipation	4 (1.7)	0 (0.0)
Diarrhea	4 (1.7)	4 (1.7)
Nausea	2 (0.9)	4 (1.7)
Vomiting	4 (1.7)	2 (0.9)
General disorders and administration site conditions		
Asthenia	3 (1.3)	1 (0.4)
Fatigue	0 (0.0)	3 (1.3)
Infections and infestations		
Bronchitis	5 (2.2)	4 (1.7)
Gastroenteritis	1 (0.4)	3 (1.3)
Influenza	9 (3.9)	9 (3.9)
Nasopharyngitis	7 (3.1)	7 (3.0)
Respiratory tract infection	3 (1.3)	2 (0.9)
Sinusitis	2 (0.9)	4 (1.7)
Upper respiratory tract infection	8 (3.5)	10 (4.3)
Urinary tract infection	5 (2.2)	5 (2.1)
Viral infection	0 (0.0)	3 (1.3)

	Number of patients (%)	
Body system/Organ class Adverse event	Sitagliptin 100 mg + Metformin + Insulin n=229	Placebo + Metformin + Insulin n=233
Investigations		
Creatinine renal clearance decreased	3 (1.3)	0 (0.0)
Metabolism and nutrition disorders		
Hypoglycemia	35 (15.3)	19 (8.2)
Musculoskeletal and connective tissue disorders		
Arthralgia	1 (0.4)	5 (2.1)
Muscle spasms	0 (0.0)	4 (1.7)
Musculoskeletal pain	2 (0.9)	3 (1.3)
Pain in extremity	4 (1.7)	2 (0.9)
Nervous system disorders		
Dizziness	2 (0.9)	3 (1.3)
Headache	3 (1.3)	2 (0.9)
Respiratory, thoracic and mediastinal disorders		
Cough	2 (0.9)	3 (1.3)

Combination Therapy: Sitagliptin Add-on to Metformin and Pioglitazone

In a 26-week placebo-controlled clinical study of patients receiving sitagliptin (100 mg daily) as add-on combination therapy with metformin and pioglitazone, the incidence of adverse events reported regardless of causality assessment, in $\geq 1\%$ of patients are shown in Table 5.

Table 5 – Adverse Events $\geq 1\%$ in Any Treatment Group (regardless of causality) Reported in Patients in a 26-Week Placebo-Controlled, Double-Blind Clinical Trial of Sitagliptin in Add-on Combination Use with Metformin and Pioglitazone

	Number of patients (%)	
Body system/Organ class Adverse event	Sitagliptin 100 mg + Metformin + Pioglitazone n=157	Placebo + Metformin + Pioglitazone n=156
Ear and Labyrinth Disorders		
Cerumen impaction	2 (1.3)	1 (0.6)
Eye Disorders		
Conjunctivitis	3 (1.9)	1 (0.6)
Ocular hyperaemia	0 (0.0)	2 (1.3)
Gastrointestinal disorders		
Abdominal pain upper	1 (0.6)	2 (1.3)
Constipation	2 (1.3)	1 (0.6)
Dental Caries	2 (1.3)	1 (0.6)
Diarrhea	3 (1.9)	4 (2.6)
Dyspepsia	1 (0.6)	2 (1.3)
Gastritis	0 (0.0)	2 (1.3)
Toothache	2 (1.3)	0 (0.0)
Vomiting	2 (1.3)	0 (0.0)
General disorders and administration site conditions		

Table 5 – Adverse Events ≥1% in Any Treatment Group (regardless of causality) Reported in Patients in a 26-Week Placebo-Controlled, Double-Blind Clinical Trial of Sitagliptin in Add-on Combination Use with Metformin and Pioglitazone

Body system/Organ class Adverse event	Number of patients (%)	
	Sitagliptin 100 mg + Metformin + Pioglitazone n=157	Placebo + Metformin + Pioglitazone n=156
Fatigue	0 (0.0)	2 (1.3)
Oedema peripheral	3 (1.9)	7 (4.5)
Infections and infestations		
Bronchitis	3 (1.9)	1 (0.6)
Cellulitis	2 (1.3)	0 (0.0)
Gastroenteritis	2 (1.3)	0 (0.0)
Gastroenteritis viral	2 (1.3)	0 (0.0)
Herpes zoster	2 (1.3)	0 (0.0)
Influenza	2 (1.3)	3 (1.9)
Nasopharyngitis	5 (3.2)	5 (3.2)
Tooth abscess	0 (0.0)	2 (1.3)
Upper respiratory tract infection	13 (8.3)	14 (9.0)
Urinary tract infection	5 (3.2)	6 (3.8)
Injury, poisoning and procedural complications		
Muscle strain	2 (1.3)	0 (0.0)
Investigations		
Blood creatine phosphokinase increased	1 (0.6)	3 (1.9)
Glomerular filtration rate decreased	2 (1.3)	0 (0.0)
Lymphocyte count increased	2 (1.3)	1 (0.6)
Neutrophil count decreased	2 (1.3)	1 (0.6)
Metabolism and nutrition disorders		
Hyperglycemia	2 (1.3)	2 (1.3)
Hypoglycemia	10 (6.4)	7 (4.5)
Musculoskeletal and connective tissue disorders		
Arthralgia	2 (1.3)	3 (1.9)
Back pain	7 (4.5)	4 (2.6)
Muscle spasms	2 (1.3)	0 (0.0)
Musculoskeletal pain	3 (1.9)	4 (2.6)
Pain in extremity	5 (3.2)	2 (1.3)
Nervous system disorders		
Headache	1 (0.6)	2 (1.3)
Psychiatric disorders		
Depression	4 (2.5)	1 (0.6)
Stress	2 (1.3)	0 (0.0)
Respiratory, thoracic and mediastinal disorders		
Cough	2 (1.3)	2 (1.3)
Oropharyngeal pain	2 (1.3)	0 (0.0)
Rhinitis allergic	2 (1.3)	0 (0.0)

In a combination therapy study with metformin and pioglitazone, hypoglycemia (sitagliptin

3.2%; placebo 1.9%), was the only drug-related adverse reaction reported by the investigator that occurred with an incidence $\geq 1\%$ in patients receiving sitagliptin and greater than in patients receiving placebo.

Less Common Clinical Trial Adverse Drug Reactions $\geq 0.1\%$ and $< 1\%$ (Drug-Related and Greater than Placebo)

Blood and Lymphatic System Disorders: anemia

Cardiac Disorders: bundle branch block, palpitations

Eye Disorders: vision blurred

Gastrointestinal Disorders: abdominal discomfort, abdominal pain upper, abdominal tenderness, constipation, diarrhea, dry mouth, dyspepsia, flatulence, irritable bowel syndrome, reflux esophagitis disease, frequent bowel movements, retching, salivary hypersecretion

General Disorders and Administration Site Conditions: asthenia, chest discomfort, face edema, hunger, irritability, malaise, peripheral edema, pain, pyrexia, thirst, xerosis

Hepatobiliary Disorders: hepatic steatosis

Infections and Infestations: gastric ulcer helicobacter, genital abscess, helicobacter gastritis, localized infection, oropharyngeal candidiasis, upper respiratory tract infection, urinary tract infection

Investigations: alanine aminotransferase increased, aspartate aminotransferase increased, blood glucose decreased, blood glucose increased, blood pressure decreased, blood pressure increased, creatinine renal clearance decreased, glomerular filtration rate decreased, white blood cell count increased

Metabolism and Nutrition Disorders: decreased appetite, hypoglycemia

Musculoskeletal and Connective Tissue Disorders: muscle tightness, muscle fatigue

Nervous System Disorders: coordination abnormal, dizziness, headache, migraine, neuropathy peripheral, parosmia, somnolence

Psychiatric Disorders: anxiety, depression, insomnia, libido decreased

Renal and Urinary Disorders: renal disorders

Reproductive System and Breast Disorders: balanoposthitis, dysmenorrhea, erectile dysfunction

Respiratory, Thoracic and Mediastinal Disorders: cough

Skin and Subcutaneous Tissue Disorders: angioneurotic oedema, dermatitis acneiform, dry skin, erythema, exanthem, hyperhidrosis, leukocytoclastic vasculitis, nail disorder, prurigo, pruritus generalized, rash, rash macular, rosacea, urticaria

Vascular Disorders: orthostatic hypotension

Atrial fibrillation/atrial flutter: In a pooled analysis of randomized clinical trials, the pooled terms atrial fibrillation/atrial flutter were observed at an incidence rate of 0.45 events per 100 patient-years in the sitagliptin-exposed group compared to 0.28 events per 100 patient-years in the non-exposed group.

TECOS Cardiovascular Safety Study:

For details pertaining to study design and patient population, see [CLINICAL TRIALS, TECOS Cardiovascular Safety Study](#).

The incidence of adjudication-confirmed pancreatitis events was higher in the sitagliptin group (0.3%) compared to the placebo group (0.2%). The sitagliptin group experienced a greater number

of severe cases of pancreatitis including two confirmed deaths due to pancreatitis, compared to none in the placebo group.

Among patients who were using insulin and/or a sulfonylurea at baseline, the incidence of severe hypoglycemia was 2.7% in sitagliptin-treated patients and 2.5% in placebo-treated patients; among patients who were not using insulin and/or a sulfonylurea at baseline, the incidence of severe hypoglycemia was 1.0% in sitagliptin-treated patients and 0.7% in placebo-treated patients.

Abnormal Hematologic and Clinical Chemistry Findings

Sitagliptin

The incidence of laboratory adverse experiences was similar in patients treated with sitagliptin 100 mg compared to patients treated with placebo. In most clinical studies, a slight decrease in alkaline phosphatase and small increases in uric acid and white blood cell (WBC) count (due to an increase in neutrophils) were observed. In active comparator studies versus a sulfonylurea agent (glipizide) similar changes were seen in alkaline phosphatase and uric acid.

Mean Change from Baseline (Standard Error)				
Study	Treatment Group	Alkaline Phosphatase (IU/L)	Uric Acid (mg/dL)	WBC (cell/microl)
Placebo-controlled ¹	Sitagliptin	-3.1 (0.4)	0.17 (0.04)	346.0 (64.3)
	Placebo	-1.3 (0.7)	0.05 (0.06)	142.4 (98.8)
Active-controlled ²	Sitagliptin	-5.7 (0.5)	0.21 (0.05)	207.8 (67.4)
	Glipizide	-3.4 (0.5)	0.20 (0.05)	86.0 (62.5)

¹ Sitagliptin in Combination with Metformin – Placebo-Controlled Study, see [CLINICAL TRIALS](#)

² Sitagliptin in Combination with Metformin – Active-Controlled (Sulfonylurea Agent) Study, see [CLINICAL TRIALS](#)

In a combination therapy study with insulin and metformin, a greater proportion of patients were observed to have a decrease in hemoglobin ≥ 1.5 g/dL in the sitagliptin group (6.8%) compared with the placebo group (2.3%).

Metformin hydrochloride

During controlled clinical trials of 29 weeks duration, approximately 9% of patients on metformin monotherapy developed asymptomatic subnormal serum vitamin B₁₂ levels; serum folic acid levels did not decrease significantly. Five cases of megaloblastic anemia have been reported with metformin administration and no increased incidence of neuropathy has been observed. However, serious cases of peripheral neuropathy have been reported with metformin treatment in the post-marketing experience in patients with vitamin B₁₂ deficiency (see [WARNINGS AND PRECAUTIONS](#) and [ADVERSE REACTIONS, Post-Marketing Adverse Drug Reactions](#)).

Post-Marketing Adverse Drug Reactions

Because these reactions are reported voluntarily from a population of uncertain size, it is generally not possible to reliably estimate their frequency or establish a causal relationship to drug exposure.

Blood and lymphatic system disorders: hemolytic anemia, some with a fatal outcome (see [WARNINGS AND PRECAUTIONS](#))

Gastrointestinal disorders: abdominal discomfort, abdominal distension, abdominal pain, abdominal pain upper, acute pancreatitis, including fatal and non-fatal hemorrhagic and necrotizing pancreatitis (see [WARNINGS AND PRECAUTIONS](#)), constipation, diarrhea, dry mouth, dyspepsia, flatulence, gastric disorder, gastric ulcer, gastrointestinal disorder, nausea, vomiting

Hepatobiliary disorders: liver function tests abnormalities or hepatitis resolving upon metformin discontinuation, autoimmune hepatitis, drug-induced liver injury, hepatitis (see [WARNINGS AND PRECAUTIONS](#))

Immune system disorders: hypersensitivity reactions including anaphylaxis, angioedema, rash, urticaria, cutaneous vasculitis and exfoliative skin conditions, including Stevens-Johnson syndrome (see [CONTRAINDICATIONS](#) and [WARNINGS AND PRECAUTIONS](#))

Investigations: blood lactic acid increased, reduction of thyrotropin level in patients with treated or untreated hypothyroidism (see [WARNINGS AND PRECAUTIONS](#))

Metabolism and nutrition disorders: lactic acidosis, decrease of vitamin B₁₂ absorption with decrease of serum levels during long-term use of metformin, weight decreased, decreased appetite, peripheral neuropathy in patients with vitamin B₁₂ deficiency, hypomagnesemia in the context of diarrhea (see [WARNINGS AND PRECAUTIONS](#))

Musculoskeletal and connective tissue disorders: arthralgia, myalgia, pain in extremity, back pain

Nervous system disorders: encephalopathy (see [WARNINGS AND PRECAUTIONS](#)), headache

Renal and urinary disorders: worsening renal function, including acute renal failure (sometimes requiring dialysis) (see [WARNINGS AND PRECAUTIONS](#))

Skin and subcutaneous tissue disorder: photosensitivity, erythema, pruritus, rash, skin lesion, urticaria, bullous pemphigoid (see [WARNINGS AND PRECAUTIONS](#))

DRUG INTERACTIONS

Overview

Pharmacokinetic drug interaction studies with JANUMET[®] or JANUMET[®] XR have not been performed; however, such studies have been conducted with the individual sitagliptin and metformin components of JANUMET[®] and JANUMET[®] XR.

The simultaneous administration of JANUMET[®] or JANUMET[®] XR and a sulfonylurea could produce a hypoglycemic reaction, especially if they are given in patients already receiving other drugs which, themselves, can potentiate the effect of sulfonylureas. These drugs can be: long-acting sulfonamides, tuberculostatics, phenylbutazone, clofibrate, monoamine oxidase inhibitors, salicylates, probenecid and propranolol.

Sitagliptin

In Vitro Assessment of Drug Interactions: Sitagliptin is not an inhibitor of CYP isozymes CYP3A4, 2C8, 2C9, 2D6, 1A2, 2C19 or 2B6, and is not an inducer of CYP3A4. Sitagliptin is a p-glycoprotein substrate, but does not inhibit p-glycoprotein mediated transport of digoxin. Based on these results, sitagliptin is considered unlikely to cause interactions with other drugs that utilize these pathways.

Sitagliptin is not extensively bound to plasma proteins. Therefore, the propensity of sitagliptin to be involved in clinically meaningful drug-drug interactions mediated by plasma protein binding displacement is very low.

Metformin hydrochloride

In Vivo Assessment of Drug Interactions: In healthy volunteers, the pharmacokinetics of propranolol and ibuprofen were not affected by metformin when co-administered in single-dose interaction studies. Metformin is negligibly bound to plasma proteins and is therefore, less likely to interact with highly protein-bound drugs such as salicylates, sulfonamides, chloramphenicol and probenecid, as compared to sulfonylureas, which are extensively bound to serum protein.

Drug-Drug Interactions

Sitagliptin

In clinical studies, as described below, sitagliptin did not meaningfully alter the pharmacokinetics of metformin, glyburide, simvastatin, rosiglitazone, warfarin, or oral contraceptives, providing *in vivo* evidence of a low propensity for causing drug interactions with substrates of CYP3A4, CYP2C8, CYP2C9, and organic cationic transporter (OCT). Multiple doses of sitagliptin slightly increased digoxin concentrations; however, these increases are not considered likely to be clinically meaningful and are not attributed to a specific mechanism.

Effects of other drugs on the pharmacokinetics of sitagliptin

Metformin: Co-administration of multiple twice-daily doses of metformin with sitagliptin did not meaningfully alter the pharmacokinetics of sitagliptin in patients with type 2 diabetes.

Cyclosporine: A study was conducted to assess the effect of cyclosporine, a potent inhibitor of p-glycoprotein, on the pharmacokinetics of sitagliptin. Co-administration of a single 100 mg oral dose of sitagliptin and a single 600 mg oral dose of cyclosporine increased the area under the plasma concentration versus time curve (AUC) and C_{max} of sitagliptin by approximately 29% and 68%, respectively. These modest changes in sitagliptin pharmacokinetics were not considered to be clinically meaningful. The renal clearance of sitagliptin was also not meaningfully altered. Therefore, meaningful interactions would not be expected with other p-glycoprotein inhibitors.

Effects of sitagliptin on the pharmacokinetics of other drugs

Metformin: Co-administration of multiple twice-daily doses of sitagliptin with metformin, an OCT substrate, did not meaningfully alter the pharmacokinetics of metformin or sitagliptin in patients with type 2 diabetes. Therefore, sitagliptin is not an inhibitor of OCT-mediated transport.

Sulfonylureas: Single-dose pharmacokinetics of glyburide, a CYP2C9 substrate, were not meaningfully altered in subjects receiving multiple doses of sitagliptin. Clinically meaningful interactions would not be expected with other sulfonylureas (e.g., glipizide, tolbutamide, and glimepiride) which, like glyburide, are primarily eliminated by CYP2C9.

Simvastatin: Single-dose pharmacokinetics of simvastatin, a CYP3A4 substrate, were not meaningfully altered in subjects receiving multiple daily doses of sitagliptin. Therefore, sitagliptin is not an inhibitor of CYP3A4-mediated metabolism.

Thiazolidinediones: Single-dose pharmacokinetics of rosiglitazone were not meaningfully altered in subjects receiving multiple daily doses of sitagliptin. Therefore, sitagliptin is not an inhibitor of CYP2C8-mediated metabolism. Clinically meaningful interactions with pioglitazone are not expected because pioglitazone predominantly undergoes CYP2C8- or CYP3A4-mediated metabolism.

Warfarin: Multiple daily doses of sitagliptin did not meaningfully alter the pharmacokinetics, as assessed by measurement of S(-) or R(+) warfarin enantiomers, or pharmacodynamics (as assessed by measurement of prothrombin International Normalized Ratio) of a single dose of warfarin. Since S(-) warfarin is primarily metabolized by CYP2C9, these data also support the conclusion that sitagliptin is not a CYP2C9 inhibitor.

Oral Contraceptives: Co-administration with sitagliptin did not meaningfully alter the steady state pharmacokinetics of norethindrone or ethinyl estradiol.

Digoxin: Sitagliptin had a minimal effect on the pharmacokinetics of digoxin. Following administration of 0.25 mg digoxin concomitantly with 100 mg of sitagliptin daily for 10 days, the plasma AUC of digoxin was increased by 11%, and the plasma C_{max} by 18%. These increases are not considered likely to be clinically meaningful.

Metformin

Carbonic Anhydrase Inhibitors: Topiramate or other carbonic anhydrase inhibitors (e.g., zonisamide, acetazolamide or dichlorphenamide) frequently cause a decrease in serum bicarbonate and induce non-anion gap, hyperchloremic metabolic acidosis. Concomitant use of these drugs with JANUMET[®] or JANUMET[®] XR may increase the risk of lactic acidosis. Consider more frequent monitoring of these patients.

Glyburide: In a single-dose interaction study in type 2 diabetes patients, co-administration of metformin and glyburide did not result in any changes in either metformin pharmacokinetics or pharmacodynamics. Decreases in glyburide AUC and C_{max} were observed, but were highly variable. The single-dose nature of this study and the lack of correlation between glyburide blood levels and pharmacodynamic effects make the clinical significance of this interaction uncertain.

Furosemide: A single-dose, metformin-furosemide drug interaction study in healthy subjects demonstrated that pharmacokinetic parameters of both compounds were affected by co-administration. Furosemide increased the metformin plasma and blood C_{max} by 22% and blood AUC by 15%, without any significant change in metformin renal clearance. When administered with metformin, the C_{max} and AUC of furosemide were 31% and 12% smaller, respectively, than when administered alone, and the terminal half-life was decreased by 32%, without any significant change in furosemide renal clearance. No information is available about the interaction of metformin and furosemide when co-administered chronically.

Nifedipine: A single-dose, metformin-nifedipine drug interaction study in normal healthy volunteers demonstrated that co-administration of nifedipine increased plasma metformin C_{max} and AUC by 20% and 9%, respectively, and increased the amount excreted in the urine. T_{max} and half-life were unaffected. Nifedipine appears to enhance the absorption of metformin. Metformin had minimal effects on nifedipine.

Drugs that reduce metformin clearance: Concomitant use of drugs that interfere with common renal tubular transport systems involved in the renal elimination of metformin (e.g., organic cationic transporter-2 [OCT2] / multidrug and toxin extrusion [MATE] inhibitors such as ranolazine, vandetanib, dolutegravir, and cimetidine) could increase systemic exposure to metformin and may increase the risk for lactic acidosis (see [WARNINGS AND PRECAUTIONS](#)). In both single- and multiple-dose metformin-cimetidine drug interaction studies, there was a 60% increase in peak metformin plasma and whole blood concentrations and a 40% increase in plasma and whole blood metformin AUC. There was no change in elimination half-life in the single-dose study. Metformin had no effect on cimetidine pharmacokinetics. Close monitoring of glycemic control, dose adjustment within the recommended posology and changes in diabetic treatment should be considered when such products are co-administered.

Levothyroxine: Levothyroxine can reduce the glucose-lowering effect of metformin. Monitoring of blood glucose levels is recommended, especially when thyroid hormone therapy is initiated, changed, or stopped (see [WARNINGS AND PRECAUTIONS](#)), and JANUMET[®]/JANUMET[®] XR dosage adjusted as necessary.

Anticoagulant: Elimination rate of the anticoagulant phenprocoumon has been reported to be increased by 20% when used concurrently with metformin. Therefore, a close monitoring of the International Normalized Ratio (INR) is recommended in patients concurrently administering metformin and phenprocoumon or other antivitamin K anticoagulants (see [WARNINGS AND PRECAUTIONS](#)). In such cases, an important increase of prothrombin time may occur upon cessation of JANUMET[®] or JANUMET[®] XR therapy, with an increased risk of hemorrhage.

Other: Certain drugs tend to produce hyperglycemia and may lead to loss of glycemic control. These drugs include the thiazides and other diuretics, corticosteroids, phenothiazines, thyroid products, estrogens, estrogen plus progestogen, oral contraceptives, phenytoin, nicotinic acid, sympathomimetics, calcium channel blocking drugs, isoniazid and beta-2-agonists. ACE-inhibitors may decrease the blood glucose levels. When such drugs are administered to a patient receiving JANUMET[®] or JANUMET[®] XR the patient should be closely observed to maintain adequate glycemic control.

Diuretics, especially loop diuretics, may increase the risk of lactic acidosis due to their potential to decrease renal function.

Drug-Food Interactions

There are no known interactions with food.

Drug-Herb Interactions

Interactions with herbal products have not been established.

Drug-Laboratory Interactions

Sitagliptin

Interactions with laboratory tests have not been established.

Metformin hydrochloride

Intravascular contrast studies with iodinated materials can lead to acute alteration of renal function and have been associated with lactic acidosis in patients receiving metformin (see [CONTRAINDICATIONS](#) and [WARNINGS AND PRECAUTIONS](#)).

Drug-Lifestyle Interactions

Effects of Smoking, Alcohol, and Diet: The effects of smoking, diet, and alcohol use on the pharmacokinetics of JANUMET[®] and JANUMET[®] XR have not been specifically studied. Patients should be cautioned against excessive alcohol intake, either acute or chronic, when taking JANUMET[®] or JANUMET[®] XR, since alcohol intake potentiates the effect of metformin on lactate metabolism (see [CONTRAINDICATIONS](#)). The risk of lactic acidosis is increased in acute alcohol intoxication, particularly in case of fasting or malnutrition or hepatic insufficiency. It is recommended that consumption of alcohol and alcohol-containing medicinal product be avoided.

Effects on Ability to Drive and Use Machines: No formal studies have been conducted with JANUMET[®] and JANUMET[®] XR on the effects on the ability to drive and use machines. However, patients should be warned about driving a vehicle or operating machinery under conditions where a risk of hypoglycemia is present (see [WARNINGS AND PRECAUTIONS](#)). When JANUMET[®] or JANUMET[®] XR is used in combination with a sulfonylurea or in combination with insulin patients should be advised to take precautions to avoid hypoglycaemia while driving or using machinery.

DOSAGE AND ADMINISTRATION

Dosing Considerations

The dosage of JANUMET[®] or JANUMET[®] XR should be individualized on the basis of the patient's current regimen, effectiveness, and tolerability while not exceeding the maximum recommended daily dose of 100 mg sitagliptin and 2000 mg metformin hydrochloride. Dose escalation should be gradual to reduce the gastrointestinal side effects associated with metformin use. Factors that may increase the risk of lactic acidosis should be reviewed before considering initiation of metformin-containing products in patients with renal impairment. Maximum daily dose of sitagliptin and metformin, as single components, in patients with an eGFR ≥ 30 mL/min/1.73 m² to <45 mL/min/1.73 m² is 50 mg and 1000 mg, respectively.

There have been reports of incompletely dissolved JANUMET[®] XR tablets being eliminated in the feces. If a patient reports seeing tablets in feces, the healthcare provider should assess adequacy of glycemic control (see [PART III: CONSUMER INFORMATION](#)). If glycemic control is found to be reduced, alternative treatments should be considered.

Concomitant Use with Insulin or an Insulin Secretagogue (e.g., Sulfonylurea)

When JANUMET[®] or JANUMET[®] XR is used as add-on therapy with insulin or an insulin secretagogue (e.g., sulfonylurea), a lower dose of insulin or the insulin secretagogue may be considered to reduce the risk of hypoglycemia (see [WARNINGS AND PRECAUTIONS](#) and [ADVERSE REACTIONS](#)).

Concomitant Use with Medication(s) that May Decrease Renal Function

Caution should be exercised when using concomitant medication(s) that may decrease renal function (like diuretics, particularly loop diuretics) or may interfere with the disposition of metformin, such as cationic drugs, that are eliminated by renal tubular secretion, due to the increased risk of developing lactic acidosis during co-administration (see [DRUG INTERACTIONS](#)).

Recommended Dose and Dosage Adjustment

JANUMET[®] is available in the following dosage strengths:

- 50 mg sitagliptin/500 mg metformin hydrochloride
- 50 mg sitagliptin/850 mg metformin hydrochloride
- 50 mg sitagliptin/1000 mg metformin hydrochloride

One JANUMET[®] tablet should be taken orally twice a day with meals to reduce the risk of gastrointestinal side effects associated with metformin use. Tablets are to be swallowed whole.

For the following dosage strengths of JANUMET[®] XR:

- 50 mg sitagliptin/500 mg metformin hydrochloride modified release tablet
- 50 mg sitagliptin/1000 mg metformin hydrochloride modified release tablet

Two JANUMET[®] XR tablets should be taken orally once a day with a meal preferably in the evening. Administration of JANUMET[®] XR with food enhances plasma concentrations of metformin. The two tablets should be taken one immediately after the other and to preserve the modified-release properties, the tablets must not be split, broken crushed, or chewed before swallowing.

For the following dosage strength of JANUMET[®] XR:

- 100 mg sitagliptin/1000 mg metformin hydrochloride modified release tablet

One single JANUMET[®] XR tablet should be taken orally once a day with a meal preferably in the evening. Administration of JANUMET[®] XR with food enhances plasma concentrations of metformin. To preserve the modified-release properties, the tablets must not be split, broken crushed, or chewed before swallowing.

In patients on metformin (alone or in combination with a sulfonylurea, pioglitazone, or insulin), the recommended total daily dose of JANUMET[®] or JANUMET[®] XR is 100 mg sitagliptin and the nearest therapeutically appropriate dose of metformin already being taken.

In patients already treated with sitagliptin and metformin, switching to JANUMET[®] or JANUMET[®] XR may be initiated at the dose of sitagliptin and metformin already being taken.

Renal Impairment: Renal function must be assessed prior to initiation of JANUMET[®] or JANUMET[®] XR and periodically thereafter because there is a dosage adjustment based upon renal function. In patients with eGFR <60 mL/min/1.73m², more intensive monitoring for glycemic biomarkers, renal biomarkers and signs and symptoms of renal dysfunction is recommended especially if the eGFR is less than 45 mL/min/1.73 m² (see [WARNINGS AND PRECAUTIONS, Monitoring and Laboratory Tests](#)).

JANUMET[®] and JANUMET[®] XR are contraindicated in patients with severe renal impairment (eGFR <30 mL/min/1.73 m²), end stage renal disease or patients on dialysis (see [CONTRAINDICATIONS](#)).

No dosage adjustment for JANUMET[®] and JANUMET[®] XR is necessary in patients with mild (eGFR ≥60 mL/min/1.73 m² to <90 mL/min/1.73 m²) to moderate renal impairment (eGFR ≥45 mL/min/1.73 m² to <60 mL/min/1.73 m²).

JANUMET[®]

JANUMET[®] is not recommended in patients with an eGFR ≥30 mL/min/1.73 m² and <45 mL/min/1.73 m² because these patients require a lower dosage of sitagliptin than what is available in the fixed combination JANUMET[®] product.

JANUMET[®] XR

Initiation of JANUMET[®] XR in patients with an eGFR ≥30 mL/min/1.73 m² and <45 mL/min/1.73 m² is not recommended. In patients taking JANUMET[®] XR whose eGFR later falls below 45 mL/min/1.73 m², assess the benefit and risk of continuing therapy and limit dose of the sitagliptin component to 50 mg once day:

- JANUMET[®] XR 50 mg/500 mg – 1 tablet once daily
- JANUMET[®] XR 50 mg/1000 mg – 1 tablet once daily

Discontinue JANUMET[®] XR if the patient's eGFR later falls below 30 mL/min/1.73 m².

Discontinuation for iodinated contrast imaging procedures:

Discontinue JANUMET[®] or JANUMET[®] XR at the time of, or prior to, an iodinated contrast imaging procedure in patients with an eGFR ≥30 to <60 mL/min/1.73 m²; in patients with a history of liver disease, alcoholism or heart failure; or in patients who will be administered intra-arterial iodinated contrast. Re-evaluate eGFR 48 hours after the imaging procedure; restart JANUMET[®] or JANUMET[®] XR if renal function is acceptable and found to be stable (see [WARNINGS AND PRECAUTIONS](#)).

Hepatic Impairment: JANUMET[®] or JANUMET[®] XR is contraindicated in patients with severe hepatic impairment and should not be used in patients with clinical or laboratory evidence of hepatic disease (see [CONTRAINDICATIONS](#)). Metformin use in patients with impaired hepatic function has been associated with some cases of lactic acidosis (see [WARNINGS AND PRECAUTIONS](#)).

Pediatrics (<18 years of age): There are no data available on the use of JANUMET[®] or JANUMET[®] XR in patients younger than 18 years of age. Therefore, use of JANUMET[®] or JANUMET[®] XR in pediatric patients is not recommended.

Geriatrics (≥65 years of age): JANUMET[®] or JANUMET[®] XR should be used with caution in patients 65 years and older. Regular assessment of renal function is necessary. Metformin and sitagliptin are excreted by the kidneys, and elderly patients are more likely to have decreased renal function associated with aging and be at risk of developing lactic acidosis (see [WARNINGS AND PRECAUTION, Special Populations](#)).

Missed Dose

If a dose of JANUMET[®] or JANUMET[®] XR is missed, it should be taken as soon as the patient remembers. If he/she does not remember until it is time for the next dose, the missed dose should be skipped and returned to the regular schedule. A double dose of JANUMET[®] or JANUMET[®] XR should not be taken at the same time.

OVERDOSAGE

For management of a suspected drug overdose, contact your regional Poison Control Centre.

Sitagliptin

In the event of an overdose, it is reasonable to employ the usual supportive measures, e.g., remove unabsorbed material from the gastrointestinal tract, employ clinical monitoring (including obtaining an electrocardiogram), and institute supportive therapy if required.

Sitagliptin is modestly dialyzable. In clinical studies, approximately 13.5% of the dose was removed over a 3- to 4-hour hemodialysis session. Prolonged hemodialysis may be considered if clinically appropriate. It is not known if sitagliptin is dialyzable by peritoneal dialysis.

Metformin hydrochloride

Available information concerning treatment of a massive overdose of metformin hydrochloride is very limited. It would be expected that adverse reactions of a more intense character including epigastric discomfort, nausea and vomiting followed by diarrhea, drowsiness, weakness, dizziness, malaise and headache might be seen. Should those symptoms persist, lactic acidosis should be excluded. The drug should be discontinued and proper supportive therapy instituted.

Overdose of metformin hydrochloride has occurred, including ingestion of amounts greater than 50 grams. Hypoglycemia was reported in approximately 10% of cases, but no causal association with metformin hydrochloride has been established. Lactic acidosis has been reported in approximately 32% of metformin overdose cases (see [WARNINGS AND PRECAUTIONS](#)). Metformin is dialyzable with a clearance of up to 170 mL/min under good hemodynamic conditions. Therefore, hemodialysis may be useful for removal of accumulated drug from patients in whom metformin overdose is suspected.

Pancreatitis may occur in the context of a metformin overdose (see [WARNINGS AND PRECAUTIONS](#)).

ACTION AND CLINICAL PHARMACOLOGY

Mechanism of Action

Sitagliptin and Metformin hydrochloride

JANUMET[®] and JANUMET[®] XR combine two antihyperglycemic agents with complementary mechanisms of action to improve glycemic control in patients with type 2 diabetes: sitagliptin phosphate, a dipeptidyl peptidase 4 (DPP-4) inhibitor, and metformin hydrochloride, a member

of the biguanide class. JANUMET[®] and JANUMET[®] XR targets three core defects of type 2 diabetes which are: decreased insulin synthesis and release, increased hepatic glucose production and decreased insulin sensitivity.

Sitagliptin

Sitagliptin is an orally-active, potent, and highly selective inhibitor of the dipeptidyl peptidase 4 (DPP-4) enzyme for the treatment of type 2 diabetes. The DPP-4 inhibitors are a class of agents that act as incretin enhancer.

Incretin hormones, including glucagon-like peptide-1 (GLP-1) and glucose-dependent insulinotropic polypeptide (GIP), are released by the intestine throughout the day, and levels are increased in response to a meal. The incretins are part of an endogenous system involved in the physiologic regulation of glucose homeostasis. When blood glucose concentrations are normal or elevated, GLP-1 and GIP increase insulin synthesis and release from pancreatic beta cells by intracellular signaling pathways involving cyclic AMP. Progressive beta-cell failure is a feature characterizing the pathogenesis of type 2 diabetes. Treatment with GLP-1 or with DPP-4 inhibitors in animal models of type 2 diabetes has been demonstrated to improve beta cell responsiveness to glucose and stimulate insulin biosynthesis and release. With higher insulin levels, tissue glucose uptake is enhanced.

In addition, GLP-1 lowers glucagon secretion from pancreatic alpha cells. Decreased glucagon concentrations, along with higher insulin levels, lead to reduced hepatic glucose production, resulting in a decrease in blood glucose levels. When blood glucose concentrations are low, stimulation of insulin release and suppression of glucagon secretion by GLP-1 are not observed. GLP-1 does not impair the normal glucagon response to hypoglycemia.

The activity of GLP-1 and GIP is limited by the DPP-4 enzyme, which rapidly hydrolyzes the incretin hormones to produce inactive products. Sitagliptin prevents the hydrolysis of incretin hormones by DPP-4, thereby increasing plasma concentrations of the active forms of GLP-1 and GIP. By enhancing active incretin levels, sitagliptin increases insulin release and decreases glucagon levels in a glucose-dependent manner.

In patients with type 2 diabetes with hyperglycemia, these changes in insulin and glucagon levels lead to lower hemoglobin A_{1c} (HbA_{1c}) and lower fasting and postprandial glucose concentrations. Sitagliptin demonstrates selectivity for DPP-4, and does not inhibit the DPP-8 or DPP-9 activity *in vitro* at concentrations approximating those from therapeutic doses. Inhibition of DPP-8 or DPP-9, but not DPP-4, is associated with toxicity in preclinical animal models and alteration of immune function *in vitro*.

Metformin hydrochloride

Metformin is a biguanide derivative producing an antihyperglycemic effect which can only be observed in man or in the diabetic animal and only when there is insulin secretion. Metformin, at therapeutic doses, does not cause hypoglycemia when used alone in man or in the non-diabetic animal, except when using a near lethal dose. Metformin has no effects on the pancreatic beta cells. The mode of action of metformin is not fully understood. It has been postulated that metformin might potentiate the effect of insulin or that it might enhance the effect of insulin on the peripheral receptor site. This increased sensitivity seems to follow an increase in the number of insulin receptors on cell surface membranes.

Pharmacodynamics

Sitagliptin

In patients with type 2 diabetes, administration of single oral doses of sitagliptin leads to inhibition of DPP-4 enzyme activity for a 24-hour period, resulting in a 2- to 3-fold increase in circulating levels of active GLP-1 and GIP, increased plasma levels of insulin and C-peptide, decreased glucagon concentrations, reduced fasting glucose, and reduced glucose excursion following an oral glucose load or a meal.

In a study of patients with type 2 diabetes inadequately controlled on metformin monotherapy, glucose levels monitored throughout the day were significantly lower ($p < 0.001$) in patients who received sitagliptin 100 mg per day (50 mg twice daily) in combination with metformin compared with patients who received placebo with metformin (see Figure 1).

Figure 1 – 24-Hour Plasma Glucose Profile after 4-Week Treatment with Sitagliptin 50 mg BID with Metformin or Placebo with Metformin

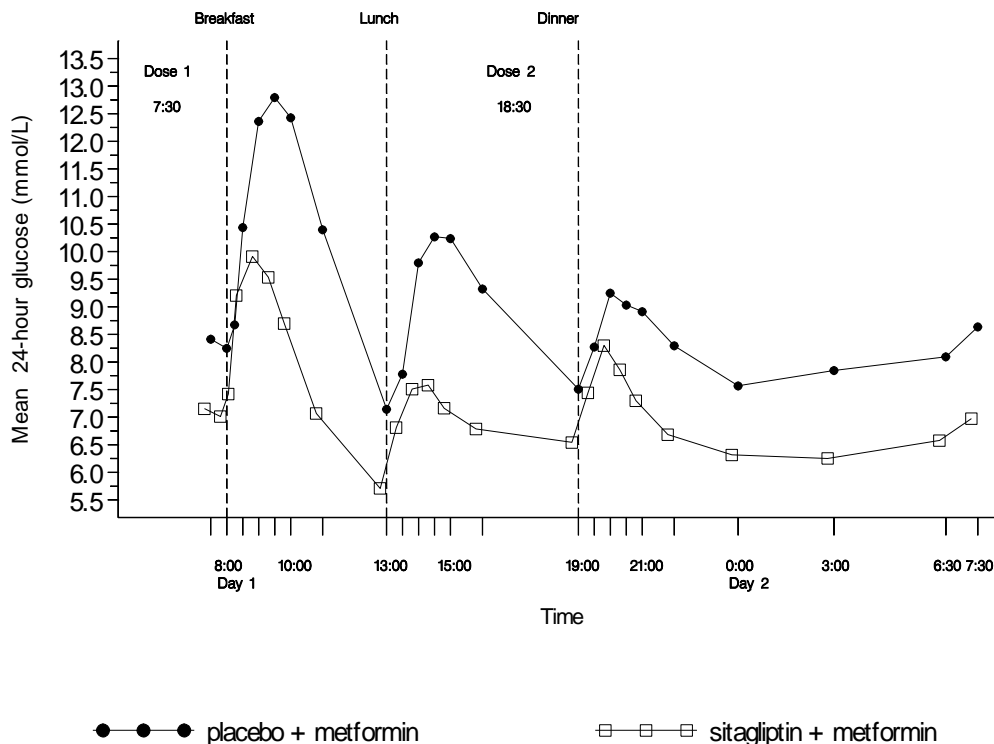

In studies with healthy subjects, sitagliptin did not lower blood glucose or cause hypoglycemia, suggesting that the insulinotropic and glucagon suppressive actions of the drug are glucose dependent.

Cardiac Electrophysiology: In a randomized, placebo-controlled crossover study, 79 healthy subjects were administered a single oral dose of sitagliptin 100 mg, sitagliptin 800 mg (8 times the recommended dose), and placebo. At the recommended dose of 100 mg, there was no effect on the QTc interval obtained at the peak plasma concentration, or at any other time during the

study. Following the 800 mg dose, the maximum increase in the placebo-corrected mean change in QTc from baseline at 3 hours post-dose was 8.0 msec (90% CI; 5.5, 10.6). At the 800 mg dose, peak sitagliptin plasma concentrations were approximately 11 times higher than the peak concentrations following a 100 mg dose.

In patients with type 2 diabetes administered sitagliptin 100 mg (N=81) or sitagliptin 200 mg (N=63) daily, there were no meaningful changes in QTc interval based on ECG data obtained at the time of expected peak plasma concentration.

Metformin hydrochloride

Few data are available on the relationship between pharmacodynamics and pharmacokinetics, and therefore the effect of metformin on glucose control cannot be predicted from pharmacokinetic data alone. Tissue concentrations of metformin in the dual target sites of the liver and muscle appear to be more informative, and the deep metformin compartment supplying these tissues is critical and related to plasma concentrations. This view substantiates the clinical observation that the glucose-lowering action of metformin takes time to be fully expressed and also that activity is not lost immediately on drug withdrawal.

Sitagliptin and Metformin Co-Administration

In a two-day study in healthy subjects, sitagliptin alone increased active GLP-1 concentrations, whereas metformin alone increased active and total GLP-1 concentrations to similar extents. Co-administration of sitagliptin and metformin has an additive effect on active GLP-1 concentrations. Sitagliptin, but not metformin, increased active GIP concentrations. It is unclear what these findings mean for changes in glycemic control in patient with type 2 diabetes.

Pharmacokinetics

JANUMET[®]

In a bioequivalence study of JANUMET[®] 50/500 and 50/1000 (mg/mg sitagliptin/metformin hydrochloride), both the sitagliptin component and the metformin component were bioequivalent to co-administered 50 mg sitagliptin phosphate tablet and metformin hydrochloride tablets 500 and 1000 mg, respectively under fasted conditions in healthy subjects.

Because bioequivalence is demonstrated at the lowest and highest combination tablet dose strengths available, bioequivalence is conferred to the (sitagliptin/metformin) 50 mg/850 mg fixed dose combination (FDC) tablet.

Table 6 – Geometric Mean Pharmacokinetic Parameters for Sitagliptin and Metformin Following Single Dose of JANUMET[®] or Co-administration of Corresponding Doses of Sitagliptin and Metformin as Individual Tablets to Healthy Subjects Under Fasted Conditions

Sitagliptin					
Treatment	Subject Number	AUC_{0-∞} (μM·hr)	C_{max} (nM)	T_{max}[†] (hr)	t_{1/2}[‡] (hr)
A	24	4.09	415	2.50	12.3
B	24	4.01	414	2.75	12.6
C	24	4.05	423	2.50	13.1
D	24	3.94	397	2.50	13.7

Table 6 – Geometric Mean Pharmacokinetic Parameters for Sitagliptin and Metformin Following Single Dose of JANUMET® or Co-administration of Corresponding Doses of Sitagliptin and Metformin as Individual Tablets to Healthy Subjects Under Fasted Conditions

Metformin					
Treatment	Subject Number	AUC_{0-∞} (µg/mL·hr)	C_{max} (ng/mL)	T_{max}[†] (hr)	t_{1/2}[‡] (hr)
A	24	7.26	1180	2.50	9.79
B	24	7.25	1180	2.75	11.6
C	24	11.9	1850	2.50	13.6
D	24	11.9	1870	2.00	13.9

[†] Median
[‡] Harmonic Mean
 Treatment A = sitagliptin 50 mg + metformin hydrochloride 500 mg
 Treatment B = JANUMET® sitagliptin (50 mg)/metformin hydrochloride (500 mg)
 Treatment C = sitagliptin 50 mg + metformin hydrochloride 1000 mg
 Treatment D = JANUMET® sitagliptin (50 mg)/metformin hydrochloride (1000 mg)

When administered in the fed state (following a standard high-fat breakfast), the metformin component of JANUMET® was bioequivalent to metformin taken together with sitagliptin as individual tablets.

JANUMET® XR

The results of studies in healthy subjects demonstrated that the JANUMET® XR 50 mg/500 mg and 100 mg/1000 mg combination tablets are bioequivalent to co-administration of corresponding individual doses of sitagliptin tablets and metformin hydrochloride extended-release tablets.

After administration of two JANUMET® XR 50 mg/1000 mg tablets once daily with the evening meal for 7 days in healthy adult subjects, steady state for sitagliptin and metformin was reached by Day 4 and 5, respectively. The median T_{max} values for sitagliptin and metformin at steady state were approximately 3 and 8 hours post-dose, respectively. The median T_{max} values for sitagliptin and metformin after administration of a single 50 mg/1000 mg tablet of JANUMET® were 3 and 3.5 hours post-dose, respectively.

Absorption:

Sitagliptin

The absolute bioavailability of sitagliptin is approximately 87%. Co-administration of a high-fat meal with sitagliptin had no effect on the pharmacokinetics of sitagliptin.

Metformin hydrochloride

Metformin absorption is relatively slow and may extend over about 6 hours.

Following a single oral dose of 1000 mg metformin hydrochloride extended-release tablet once-daily after a meal, the time to reach maximum plasma metformin concentration (T_{max}) is approximately 7 - 8 hours. In both single and multiple dose studies in healthy subjects, once daily 1000 mg dosing provides equivalent systemic exposure, as measured by area-under-the-curve (AUC), of metformin relative to the immediate release given as 500 mg twice daily.

Once daily oral doses of metformin hydrochloride extended-release 500 mg to 2500 mg doses resulted in less than proportional increases in both AUC and C_{max}. The mean C_{max} values were 473 ± 145, 868 ± 223, 1171 ± 297, and 1630 ± 399 ng/mL for once daily doses of 500, 1000,

1500, and 2500 mg, respectively. For AUC, the mean values were 3501 ± 796 , 6705 ± 1918 , 9299 ± 2833 , and 14161 ± 4432 ng.hr/mL for once daily doses of 500, 1000, 1500, and 2500 mg, respectively.

Low-fat and high-fat meals increased the systemic exposure (as measured by AUC) from 500 mg metformin hydrochloride extended-release tablets by about 38% and 73%, respectively, relative to fasting. Both meals prolonged metformin T_{max} by approximately 3 hours but C_{max} was not affected.

Distribution:

Sitagliptin

The mean volume of distribution at steady state following a single 100 mg intravenous dose of sitagliptin to healthy subjects is approximately 198 liters. The fraction of sitagliptin reversibly bound to plasma proteins is low (38%).

Metformin hydrochloride

Plasma protein binding is negligible. Metformin partitions into erythrocytes. The blood peak is lower than the plasma peak and appears at approximately the same time. The red blood cells most likely represent a secondary compartment of distribution. The mean volume of distribution (V_d) ranged between 63-276 l.

Metabolism:

Sitagliptin

Sitagliptin is primarily eliminated unchanged in urine, and metabolism is a minor pathway. Approximately 79% of sitagliptin is excreted unchanged in the urine.

Following a [^{14}C] sitagliptin oral dose, approximately 16% of the radioactivity was excreted as metabolites of sitagliptin. Six metabolites were detected at trace levels and are not expected to contribute to the plasma DPP-4 inhibitory activity of sitagliptin. *In vitro* studies indicated that the primary enzyme responsible for the limited metabolism of sitagliptin was CYP3A4, with contribution from CYP2C8.

Metformin hydrochloride

Metformin is not metabolized. Its main sites of concentration are the intestinal mucosa and the salivary glands. The plasma concentration at steady-state ranges about 1 to 2 mcg/mL. Certain drugs may potentiate the effects of metformin (see [WARNINGS AND PRECAUTIONS](#) and [DRUG INTERACTIONS](#)).

Excretion:

Sitagliptin

Following administration of an oral [^{14}C] sitagliptin dose to healthy subjects, approximately 100% of the administered radioactivity was eliminated in feces (13%) or urine (87%) within one week of dosing. The apparent terminal $t_{1/2}$ following a 100-mg oral dose of sitagliptin was approximately 12.4 hours and renal clearance was approximately 350 mL/min.

Elimination of sitagliptin occurs primarily via renal excretion and involves active tubular secretion. Sitagliptin is a substrate for human organic anion transporter-3 (hOAT-3), which may be involved in the renal elimination of sitagliptin. The clinical relevance of hOAT-3 in sitagliptin transport has not been established. Sitagliptin is also a substrate of p-glycoprotein, which may

also be involved in mediating the renal elimination of sitagliptin. However, cyclosporine, a p-glycoprotein inhibitor, did not reduce the renal clearance of sitagliptin.

Metformin hydrochloride

The drug is excreted in urine at high renal clearance rate of about 450 mL/min. The initial elimination of metformin is rapid with a half-life varying between 1.7 and 3 hours. The terminal elimination phase accounting for about 4 to 5 % of the absorbed dose is slow with a half-life between 9 and 17 hours.

Special Populations and Conditions

Pediatrics: No studies with JANUMET[®] or JANUMET[®] XR have been performed in pediatric patients.

Geriatrics:

Sitagliptin

Age did not have a clinically meaningful impact on the pharmacokinetics of sitagliptin based on a population pharmacokinetic analysis of Phase I and Phase II data. Elderly subjects (65 to 80 years) had approximately 19% higher plasma concentrations of sitagliptin compared to younger subjects.

Metformin hydrochloride

Controlled clinical studies of metformin did not include sufficient numbers of elderly patients to determine whether they respond differently from younger patients.

Limited data from controlled pharmacokinetic studies of metformin hydrochloride in healthy elderly subjects suggest that total plasma clearance of metformin is decreased, the half-life is prolonged and C_{max} is increased, compared to healthy young subjects. From these data, it appears that the change in metformin pharmacokinetics with aging is primarily accounted for by a change in renal function (see Warnings and Precautions, Special Populations).

Gender:

Sitagliptin

Gender had no clinically meaningful effect on the pharmacokinetics of sitagliptin based on a composite analysis of Phase I pharmacokinetic data and on a population pharmacokinetic analysis of Phase I and Phase II data.

Metformin hydrochloride

In the pharmacokinetic studies in healthy volunteers, there were no important differences between male and female subjects with respect to metformin AUC (males = 268, females = 293) and $t_{1/2}$ (males = 229, females = 260). However, C_{max} for metformin were somewhat higher in female subjects (Female/Male C_{max} Ratio = 1.4). The gender differences for C_{max} are unlikely to be clinically important.

Race:

Sitagliptin

Race had no clinically meaningful effect on the pharmacokinetics of sitagliptin based on a composite analysis of Phase I pharmacokinetic data and on a population pharmacokinetic

analysis of Phase I and Phase II data, including subjects of White, Hispanic, Black and Asian racial groups.

Metformin hydrochloride

In studies conducted with metformin extended-release, there were no definitive conclusions on the differences between the races with respect to the pharmacokinetics because of the imbalance in the respective sizes of the racial groups. However, the data suggest a trend towards higher metformin C_{max} and AUC values for metformin in Asian subjects when compared to Caucasian, Hispanic and Black subjects. The differences between the Asian and Caucasian groups are unlikely to be clinically important.

Hepatic Impairment:

JANUMET[®] or JANUMET[®] XR is contraindicated in patients with severe hepatic impairment and should not be used in patients with clinical or laboratory evidence of hepatic disease (see [CONTRAINDICATIONS](#)).

Sitagliptin

In patients with moderate hepatic impairment (Child-Pugh score 7 to 9), mean AUC and C_{max} of sitagliptin increased approximately 21% (90% CI: 1%, 46%) and 13% (90% CI: -9%, 42%), respectively, compared to healthy matched controls following administration of a single 100 mg dose of sitagliptin.

Metformin hydrochloride

No pharmacokinetic studies of metformin have been conducted in patients with hepatic impairment.

Renal Impairment: JANUMET[®] or JANUMET[®] XR is contraindicated in patients with severe renal impairment (eGFR <30 mL/min/1.73 m²) (see [CONTRAINDICATIONS](#)).

Sitagliptin

A single-dose, open-label study was conducted to evaluate the pharmacokinetics of a reduced dose of sitagliptin (50 mg) in patients with varying degrees of chronic renal insufficiency compared to normal healthy control subjects. The study included patients with mild, moderate, and severe renal impairment, as well as patients with ESRD on hemodialysis. In addition, the effects of renal impairment on sitagliptin pharmacokinetics in patients with type 2 diabetes and mild, moderate or severe renal impairment (including ESRD) were assessed using population pharmacokinetic analyses.

Compared to normal healthy control subjects, an approximate 1.2 to 1.6-fold increase in plasma AUC of sitagliptin was observed in patients with mild renal impairment (eGFR ≥ 60 mL/min/1.73 m² to <90 mL/min/1.73 m²) and patients with moderate renal impairment (eGFR ≥ 45 mL/min/1.73 m² to <60 mL/min/1.73 m²), respectively, which is not a clinically meaningful increase to require dosage adjustment.

An approximately 2-fold increase in the plasma AUC of sitagliptin was observed in patients with moderate renal impairment (eGFR ≥ 30 mL/min/1.73 m² to <45 mL/min/1.73 m²) and an approximately 4-fold increase was observed in patients with severe renal impairment (eGFR

<30 mL/min/1.73 m²) including patients with ESRD on hemodialysis, as compared to normal healthy control subjects.

To achieve plasma concentrations of sitagliptin similar to those in patients with normal renal function, lower dosages are recommended in patients with eGFR <45 mL/min/1.73 m² (see [WARNINGS AND PRECAUTIONS](#) and [DOSAGE AND ADMINISTRATION](#)).

Metformin hydrochloride

In patients with decreased renal function, the plasma and blood half-life of metformin is prolonged and the renal clearance is decreased (see [CONTRAINDICATIONS](#) and [WARNINGS AND PRECAUTIONS](#)).

STORAGE AND STABILITY

The product should be stored at 15°C to 30 °C.

DOSAGE FORMS, COMPOSITION AND PACKAGING

JANUMET[®]

Tablets JANUMET[®], 50 mg/500 mg, are light pink, capsule-shaped, film-coated tablets with “575” debossed on one side. They are supplied in bottles of 60.

Tablets JANUMET[®], 50 mg/850 mg, are pink, capsule-shaped, film-coated tablets with “515” debossed on one side. They are supplied in bottles of 60.

Tablets JANUMET[®], 50 mg/1000 mg, are red, capsule-shaped, film coated tablets with “577” debossed on one side. They are supplied in bottles of 60.

JANUMET[®] is available for oral administration as tablets containing 64.25 mg sitagliptin phosphate monohydrate and metformin hydrochloride equivalent to: 50 mg sitagliptin as free base and 500 mg metformin hydrochloride (JANUMET[®] 50 mg/500 mg), 850 mg metformin hydrochloride (JANUMET[®] 50 mg/850 mg) or 1000 mg metformin hydrochloride (JANUMET[®] 50 mg/1000 mg).

Each film-coated tablet of JANUMET[®] contains the following inactive ingredients: microcrystalline cellulose, polyvinylpyrrolidone, sodium lauryl sulfate, and sodium stearyl fumarate. In addition, the film coating contains the following inactive ingredients: polyvinyl alcohol, polyethylene glycol, talc, titanium dioxide, red iron oxide, and black iron oxide.

JANUMET[®] XR

Tablets JANUMET[®] XR, 50 mg/500 mg, are light blue, bi-convex oval, film coated tablet, debossed “78” on one side and plain on the other. They are supplied in bottles of 60.

Tablets JANUMET[®] XR, 50 mg/1000 mg, light green, bi-convex oval, film coated tablet, debossed “80” on one side and plain on the other. They are supplied in bottles of 60.

Tablets JANUMET® XR, 100 mg/1000 mg, blue, bi-convex oval, film coated tablet, debossed “81” on one side and plain on the other. They are supplied in bottles of 30.

JANUMET® XR consists of an extended-release metformin core tablet coated with an immediate release layer of sitagliptin. The sitagliptin layer is coated with a soluble polymeric film that provides taste masking.

JANUMET® XR is available for oral administration as tablets containing 64.25 mg sitagliptin phosphate monohydrate (equivalent to 50 mg sitagliptin as free base) and either 500 mg metformin hydrochloride extended-release (JANUMET® XR 50 mg/500 mg) or 1000 mg metformin hydrochloride extended-release (JANUMET® XR 50 mg/1000 mg). Additionally, JANUMET® XR is available for oral administration as tablets containing 128.5 mg sitagliptin phosphate monohydrate (equivalent to 100 mg sitagliptin as free base) and 1000 mg metformin hydrochloride extended-release (100 mg/1000 mg).

All doses of JANUMET® XR contain the following inactive ingredients: povidone, hypromellose, colloidal silicon dioxide, sodium stearyl fumarate, propyl gallate, polyethylene glycol, and kaolin. The JANUMET® XR 50 mg/500 mg tablet contains the additional inactive ingredient microcrystalline cellulose. In addition, the film coating contains the following inactive ingredients: hypromellose, hydroxypropyl cellulose, titanium dioxide, FD&C Blue #2/Indigo Carmine Aluminum Lake and carnauba wax. The JANUMET® XR 50 mg/1000 mg tablet contains the additional inactive ingredient yellow iron oxide.

PART II : SCIENTIFIC INFORMATION

PHARMACEUTICAL INFORMATION

Drug Substance

Common name/ Proper name : sitagliptin phosphate monohydrate metformin hydrochloride

Chemical name : 7-[(3*R*)-3-amino-1-oxo-4-(2,4,5-trifluorophenyl)butyl]-5,6,7,8-tetrahydro-3-(trifluoromethyl)-1,2,4-triazolo[4,3-*a*]pyrazine phosphate (1 :1) monohydrate. *N,N*-dimethyl biguanide hydrochloride

Molecular formula : $C_{16}H_{15}F_6N_5O \cdot H_3PO_4 \cdot H_2O$ $C_4H_{11}N_5 \cdot HCl$

Molecular mass : 523.32 165.63

Structural formula :

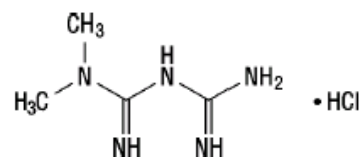
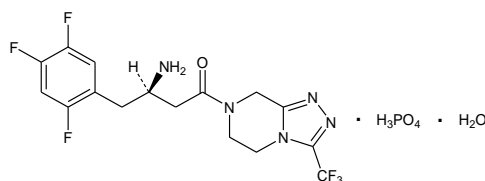

Physicochemical properties :

Sitagliptin phosphate monohydrate is a white to off-white, crystalline, non-hygroscopic powder. It is soluble in water and *N,N*-dimethyl formamide; slightly soluble in methanol; very slightly soluble in ethanol, acetone, and acetonitrile; and insoluble in isopropanol and isopropyl acetate.

Metformin hydrochloride is a white to off-white crystalline compound. It is freely soluble in water and is practically insoluble in acetone, ether and chloroform. The pK_a of metformin is 12.4. The pH of a 1% aqueous solution of metformin hydrochloride is 6.68.

CLINICAL TRIALS

Clinical studies of the co-administration of sitagliptin and metformin demonstrated significant improvements in glycemic control in patients with type 2 diabetes. None of the clinical efficacy studies described below were conducted with JANUMET[®] or JANUMET[®] XR tablets; however, bioequivalence of JANUMET[®] tablets with co-administered sitagliptin and immediate-release metformin hydrochloride tablets and JANUMET[®] XR tablets with co-administered sitagliptin and extended-release metformin tablets has been demonstrated (see [ACTION AND CLINICAL PHARMACOLOGY](#)).

Regimens of extended-release 500 mg metformin were at least as effective as corresponding regimens of an immediate-release 500 mg metformin in all measures of glycemic control. Additionally, once daily administration of two 500 mg extended-release metformin tablets was as effective as the commonly prescribed twice daily administration of the 500 mg immediate-release metformin formulation.

The combination of sitagliptin and metformin has been evaluated for safety and efficacy in four double-blind, placebo-controlled studies and in one double-blind, active controlled clinical study in patients with type 2 diabetes mellitus. In all studies, patients with inadequate glycemic control on stable doses of metformin ≥ 1500 mg were randomized to receive either sitagliptin 100 mg per day, or placebo or an active comparator, in addition to ongoing background therapy.

Sitagliptin in Combination with Metformin

Placebo-Controlled Study: A total of 701 patients with type 2 diabetes participated in a 24-week, randomized, double-blind, placebo-controlled study designed to assess the efficacy of sitagliptin in combination with metformin. All patients were started on metformin monotherapy and the dose increased to at least 1500 mg per day. Patients were randomized to the addition of either 100 mg of sitagliptin or placebo, administered once daily. Patients with congestive heart failure requiring pharmacological treatment were excluded from this study.

In combination with metformin, sitagliptin provided significant improvements in HbA_{1c}, FPG, and 2-hour PPG compared to placebo with metformin (Table 7). The improvement in HbA_{1c} was not affected by baseline HbA_{1c}, prior anti-hyperglycemic therapy, gender, age, baseline BMI, length of time since diagnosis of diabetes, presence of metabolic syndrome (according to NCEP criteria), or standard indices of insulin resistance (HOMA-IR) or insulin secretion (HOMA- β). Body weight decreased from baseline in both treatment groups.

Table 7 – Glycemic Parameters and Body Weight at Final Visit (24 Week Study) for Sitagliptin in Combination with Metformin[†]

	Sitagliptin 100 mg + Metformin	Placebo + Metformin
HbA_{1c} (%)	N=453	N=224
Baseline (mean)	8.0	8.0
Change from baseline (adjusted mean [‡])	-0.7	-0.0
Difference from placebo + metformin (adjusted mean [‡])	-0.7 [§]	
Patients (%) achieving HbA _{1c} <7%	213 (47.0%)	41 (18.3%)
FPG (mmol/L)	N=454	N=226
Baseline (mean)	9.4	9.6
Change from baseline (adjusted mean [‡])	-0.9	0.5
Difference from placebo + metformin (adjusted mean [‡])	-1.4 [§]	
2-hour PPG (mmol/L)	N=387	N=182
Baseline (mean)	15.3	15.1
Change from baseline (adjusted mean [‡])	-3.4	-0.6
Difference from placebo + metformin (adjusted mean [‡])	-2.8 [§]	
Body Weight (kg)[*]	N=399	N=169
Baseline (mean)	86.9	87.6
Change from baseline (adjusted mean [‡])	-0.7	-0.6
Difference from placebo + metformin (adjusted mean [‡])	-0.1 [¶]	

[†] All Patients Treated Population (an intention-to-treat analysis).

[‡] Least squares means adjusted for prior antihyperglycemic therapy and baseline value.

[§] p<0.001 compared to placebo + metformin.

^{*}All Patients as Treated (APaT) population, excluding patients given glycemic rescue therapy.

[¶]Not statistically significant (p≥0.05) compared to placebo + metformin.

Active-Controlled (Sulfonylurea Agent) Study: Long-term maintenance of effect was evaluated in a 52-week, double-blind, glipizide-controlled trial in patients with type 2 diabetes and inadequate glycemic control on metformin monotherapy at ≥1500 mg/day. In this study, patients were randomized to the addition of either sitagliptin 100 mg daily (N=588) or glipizide (N=584) for 52 weeks. Patients receiving glipizide were given an initial dosage of 5 mg/day and then electively titrated by the investigator to a target FPG of 6.1 mmol/L, without significant hypoglycemia, over the next 18 weeks. A maximum dosage of 20 mg/day was allowed to optimize glycemic control. Thereafter, the glipizide dose was to have been kept constant. The mean daily dose of glipizide after the titration period was 10.3 mg.

Both treatments resulted in a statistically significant improvement in glycemic control from baseline. After 52 weeks, the reduction from baseline in HbA_{1c} was 0.67% for sitagliptin 100 mg daily and 0.67% for glipizide, confirming the non-inferiority of sitagliptin compared to glipizide. The reduction in FPG was 0.6 mmol/L for sitagliptin and 0.4 mmol/L for glipizide. In this study, the proinsulin to insulin ratio, a marker of efficiency of insulin synthesis and release, improved with sitagliptin relative to glipizide. The incidence of hypoglycemia in the sitagliptin group (4.9%) was significantly lower than that in the glipizide group (32.0%). Patients treated with sitagliptin exhibited a significant mean decrease from baseline in body weight compared to a significant weight gain in patients administered glipizide (-1.5 kg vs. +1.1 kg).

Sitagliptin Add-on Combination Therapy

Add-on Combination Therapy with Metformin plus Glimepiride: In a 24-week, randomized, double-blind, placebo-controlled study designed to assess the efficacy of sitagliptin 100 mg once daily (N=116) compared to placebo (N=113), 229 patients were on the combination of glimepiride (≥4 mg per day) and metformin (≥1500 mg per day); the results of the glycemic endpoints, including HbA_{1c} and FPG, are described below.

The combination of sitagliptin, glimepiride, and metformin provided significant reduction from baseline in HbA_{1c} and FPG compared to placebo (see Table 8). Mean reductions from baseline in HbA_{1c} compared with placebo were generally greater for patients with higher baseline HbA_{1c} values. Patients treated with sitagliptin, had a modest increase in body weight (0.4 kg) compared to those given placebo who had a significant decrease in body weight (-0.7 kg).

Table 8 – Glycemic Parameters and Body Weight at Final Visit (24-Week Study) for Sitagliptin in Add-on Combination Therapy with Metformin plus Glimepiride[†]

	Sitagliptin 100 mg + Metformin + Glimepiride	Placebo + Metformin + Glimepiride
HbA_{1c} (%)	N=115	N=105
Baseline (mean)	8.27	8.28
Change from baseline (adjusted mean [‡])	-0.59	0.30
Difference from placebo (adjusted mean [‡])	-0.89 [§]	
Patients (%) achieving HbA _{1c} <7%	26 (22.6)	1 (1.0)
FPG (mmol/L)	N=115	N=109
Baseline (mean)	9.95	9.93
Change from baseline (adjusted mean [‡])	-0.43	0.72
Difference from placebo (adjusted mean [‡])	-1.15 [§]	
Body Weight (kg)[*]	N=102	N=74
Baseline (mean)	86.5	84.6
Change from baseline (adjusted mean [‡])	0.4	-0.7
Difference from placebo (adjusted mean [‡])	1.1 ^{††}	

[†] All Patients Treated Population (an intention-to-treat analysis).

[‡] Least squares means adjusted for prior antihyperglycemic therapy status and baseline value.

[§] p<0.001 compared to placebo.

^{*} All Patients as Treated (APaT) population, excluding patients given glycemic rescue therapy.

^{††} p=0.007 compared to placebo.

Add-on Combination Therapy with Metformin and Insulin: A total of 641 patients with type 2 diabetes participated in a 24-week, randomized, double-blind, placebo-controlled study designed to assess the efficacy of sitagliptin 100 mg once daily in combination with insulin.

Approximately 75% (n=462) of patients were also taking metformin. Patients with an HbA_{1c} of 7.5% to 11.0% while on a stable regimen of pre-mixed, long-acting or intermediate acting insulin, and metformin (≥ 1500 mg per day) were randomized to the addition of either 100 mg of sitagliptin or placebo. Patients using pre-meal short-acting or rapid-acting insulins that were not components of a pre-mixed insulin formulation, or that were administered via insulin pumps, were not included in this study. Glycemic endpoints measured included HbA_{1c}, FPG and 2-hour PPG. The combination of sitagliptin, metformin and insulin provided significant improvements in HbA_{1c}, FPG and 2-hour PPG compared to placebo, metformin and insulin (Table 9). There was no meaningful change from baseline in body weight in either group.

Table 9 – Glycemic Parameters and Body Weight at Final Visit (24-Week Study) for Sitagliptin as Add-on Combination Therapy with Metformin and Insulin[†]

	Sitagliptin 100 mg + Insulin + Metformin	Placebo + Insulin + Metformin
HbA_{1c} (%)	N=223	N=229
Baseline (mean)	8.7	8.6
Change from baseline (adjusted mean [‡])	-0.7	-0.1
Difference from placebo (adjusted mean ^{‡, §})	-0.5*	
Patients (%) achieving HbA _{1c} <7%	32 (14.3)	12 (5.2)
FPG (mmol/L)	N=225	N=229
Baseline (mean)	9.6	9.8
Change from baseline (adjusted mean [‡])	-1.2	-0.2
Difference from placebo (adjusted mean [‡])	-1.0*	
2-hour PPG (mmol/L)	N=182	N=189
Baseline (mean)	15.6	15.6
Change from baseline (adjusted mean [‡])	-2.2	0.1
Difference from placebo (adjusted mean [‡])	-2.2*	
Body Weight (kg)[¶]	N=201	N=200
Baseline (mean)	87.9	88.0
Change from baseline (adjusted mean [‡])	-0.1	0.0
Difference from placebo (adjusted mean [‡])	-0.1 [#]	

[†] All Patients Treated Population (an intention-to-treat analysis).

[‡] Least squares mean adjusted for insulin use at Visit 1 (premixed vs. non-pre-mixed [intermediate- or long-acting]), and baseline value.

[§] Treatment by insulin stratum interaction was not significant (p>0.10).

* p<0.001 compared to placebo.

[¶] All Patients as Treated (APaT) population, excluding data following glycemic rescue therapy.

[#] Not statistically significant (p \geq 0.05) compared to placebo.

Add-on Combination Therapy with Metformin plus Pioglitazone: A total of 313 patients with type 2 diabetes participated in a 26-week, randomized, double-blind, placebo-controlled study designed to assess the efficacy of sitagliptin in combination with pioglitazone and metformin. Patients with inadequate glycemic control on a stable regimen of pioglitazone (30 or 45 mg per day) and metformin (≥ 1500 mg per day) were randomized to the addition of either 100 mg of sitagliptin or placebo, administered once daily.

In combination with pioglitazone and metformin, sitagliptin provided significant improvements in HbA_{1c}, FPG, and 2-hour PPG compared to placebo with pioglitazone and metformin

(Table 10). Lipid effects were generally neutral. The difference between sitagliptin and placebo in body weight change was not significant.

Table 10 – Glycemic Parameters and Body Weight at Final Visit (26-Week Study) for Sitagliptin as Add-on Combination Therapy with Pioglitazone and Metformin[†]

	Sitagliptin 100 mg + Pioglitazone 30 or 45 mg + Metformin	Placebo + Pioglitazone 30 or 45 mg + Metformin
HbA_{1c} (%)	N=152	N=153
Baseline (mean)	8.8	8.6
Change from baseline (adjusted mean [‡])	-1.2	-0.4
Difference from placebo (adjusted mean [‡])	-0.7 [§]	
Patients (%) achieving HbA _{1c} <7%	38 (25.0)	15 (9.8)
FPG (mmol/L)	N=155	N=153
Baseline (mean)	10.0	9.6
Change from baseline (adjusted mean [‡])	-1.1	-0.2
Difference from placebo (adjusted mean [‡])	-1.0 [§]	
2-hour PPG (mmol/L)	N=141	N=135
Baseline (mean)	15.3	14.7
Change from baseline (adjusted mean [‡])	-3.0	-0.8
Difference from placebo (adjusted mean [‡])	-2.2 [§]	
Body Weight (kg)[*]	N=146	N=128
Baseline (mean)	81.4	82.0
Change from baseline (adjusted mean [‡])	1.3	1.1
Difference from placebo (adjusted mean [‡])	0.1 [¶]	

[†] Full Analysis Set population (an intention-to-treat analysis).

[‡] Least squares mean adjusted for baseline value.

[§] p<0.001 compared to placebo.

^{*} All Patients as Treated (APaT) population, excluding data following glycemic rescue therapy.

[¶] Not statistically significant (p≥0.05) compared to placebo.

TECOS Cardiovascular Safety Study: The Trial Evaluating Cardiovascular Outcomes with Sitagliptin (TECOS) was a randomized, double-blind, placebo-controlled, parallel-group, event-driven, multicenter study in patients with type 2 diabetes mellitus (HbA_{1c} ≥6.5 to 8.0%) and established vascular disease (coronary artery disease, ischemic cerebrovascular disease, atherosclerotic peripheral artery disease). The study included 14,671 patients (70.7% male, 29.3% female) in the intention-to-treat population who received sitagliptin (N=7,332) 100 mg daily (or 50 mg daily if the baseline eGFR was ≥30 and <50 mL/min/1.73 m²) or placebo (N=7,339) added to usual care targeting regional standards for HbA_{1c} and CV risk factors. The median duration of treatment was 31 months and the median duration of follow-up was 36 months. Patients with an eGFR <30 mL/min/1.73 m² were not to be enrolled in the study. The study population included 10,863 patients with coronary artery disease, 3,588 patients with cerebrovascular disease, 2,433 patients with peripheral artery disease, 2,643 patients with prior congestive heart failure (including 373 with New York Heart Association [NYHA] class 3 or higher), 2,004 patients ≥75 years of age and 3,324 patients with renal impairment (eGFR <60 mL/min/1.73 m²).

The primary cardiovascular endpoint was a composite of the first occurrence of cardiovascular death, non-fatal myocardial infarction, non-fatal stroke, or hospitalization for unstable angina. Secondary cardiovascular endpoints included a composite of the first occurrence of cardiovascular death, non-fatal myocardial infarction, or non-fatal stroke; as well as first occurrence of the following independent CV endpoints: cardiovascular death, myocardial infarction (fatal + non-fatal), stroke (fatal + non-fatal), hospitalization for unstable angina, hospitalization for heart failure, and all-cause mortality. A composite endpoint of first occurrence of death due to heart failure or hospitalization for congestive heart failure was also assessed.

Sitagliptin, when added to usual care, did not increase the risk of major adverse cardiovascular events or the risk of death or hospitalization for heart failure compared to usual care without sitagliptin patients with type 2 diabetes. Superiority to placebo was not demonstrated for any endpoint (Table 11).

Table 11 – Rates of Composite Cardiovascular Outcomes and Key Secondary Outcomes Censored at End of Follow-up (Intention-to-Treat Population)

	Sitagliptin (N=7,332)		Placebo (N=7,339)		Hazard Ratio (95% CI)	p-value [†]
	Subjects with Events N (%)	Incidence Rate per 100 Patient-Years*	Subjects with Events N (%)	Incidence Rate per 100 Patient-Years*		
Primary Composite Endpoint (Cardiovascular death, non-fatal myocardial infarction, non-fatal stroke, or hospitalization for unstable angina)	839 (11.4)	4.1	851 (11.6)	4.2	0.98 (0.89, 1.08)	<0.001
Secondary Composite Endpoint (Cardiovascular death, non-fatal myocardial infarction, or non-fatal stroke)	745 (10.2)	3.6	746 (10.2)	3.6	0.99 (0.89, 1.10)	<0.001
Secondary Outcome						
Cardiovascular death	380 (5.2)	1.7	366 (5.0)	1.7	1.03 (0.89, 1.19)	0.711
All myocardial infarction (fatal and non-fatal)	300 (4.1)	1.4	316 (4.3)	1.5	0.95 (0.81, 1.11)	0.487
All stroke (fatal and non-fatal)	178 (2.4)	0.8	183 (2.5)	0.9	0.97 (0.79, 1.19)	0.760
Hospitalization for unstable angina	116 (1.6)	0.5	129 (1.8)	0.6	0.90 (0.70, 1.16)	0.419
Death from any cause	547 (7.5)	2.5	537 (7.3)	2.5	1.01 (0.90, 1.14)	0.875
Hospitalization for heart failure [‡]	228 (3.1)	1.1	229 (3.1)	1.1	1.00 (0.83, 1.20)	0.983
Death due to heart failure or hospitalization for heart failure [‡]	237 (3.2)	1.1	240 (3.3)	1.1	0.99 (0.83, 1.18)	0.909

* Incidence rate per 100 patient-years is calculated as $100 \times (\text{total number of patients with } \geq 1 \text{ event during eligible exposure period per total patient-years of follow-up})$.

[†] Based on a Cox model stratified by region. For composite endpoints, the p-values correspond to a test of non-inferiority seeking to show that the hazard ratio is less than 1.3. For all other endpoints, the p-values correspond to a test of differences in hazard rates.

[‡] The analysis of hospitalization for heart failure was adjusted for a history of heart failure at baseline.

Metformin hydrochloride

The prospective randomized (UKPDS) study has established the long-term benefit of intensive blood glucose control in adult patients with type 2 diabetes. Analysis of the results for overweight patients treated with metformin after failure of diet alone showed:

- A significant reduction of the absolute risk of any diabetes-related complication in the metformin group (29.8 events/1000 patient-years) versus diet alone (43.3 events/1000 patient-years), $p=0.0023$, and versus the combined sulfonylurea and insulin monotherapy groups (40.1 events/1000 patient-years), $p=0.0034$.

- A significant reduction of the absolute risk of diabetes-related mortality: metformin 7.5 events/1000 patient-years, diet alone 12.7 events/1000 patient-years, $p=0.017$. There was no significant difference between the metformin group and those assigned intensive therapy with sulfonylurea or insulin.
- A significant reduction of the absolute risk of overall mortality: metformin 13.5 events/1000 patient-years versus diet alone 20.6 events/1000 patient-years ($p=0.011$), and versus the combined sulfonylurea and insulin monotherapy groups 18.9 events/1000 patient-years ($p=0.021$).
- A significant reduction in the absolute risk of myocardial infarction: metformin 11 events/1000 patient-years, diet alone 18 events/1000 patient-years ($p=0.01$). There was no significant difference between the metformin group and those assigned intensive therapy with sulfonylurea or insulin.
- There were no significant differences between the metformin group and the diet alone in the other aggregate endpoints (stroke, peripheral vascular disease and microvascular complications).

DETAILED PHARMACOLOGY

Sitagliptin

Sitagliptin was assessed for its ability to improve glucose tolerance in lean and diet-induced obese (DIO) mice following dextrose challenge and in diabetic (db/db) mice. In lean and DIO mice, single oral doses of sitagliptin reduced blood glucose levels in a dosage-dependent manner. Acute lowering of blood glucose was also demonstrated in diabetic db/db mice. A 2- to 3-fold increase in active GLP-1 was seen at the maximally effective dose of 1 mg/kg sitagliptin in lean mice. These results are consistent with the action of sitagliptin as an anti-hyperglycemic agent.

Treatment with GLP-1 or with DPP-4 inhibitors in animal models of type 2 diabetes has been demonstrated to improve beta cell responsiveness to glucose, stimulate insulin biosynthesis and release, increase beta cell neogenesis, and decrease beta cell death. The effects on beta cell neogenesis and beta cell death have not been studied in humans.

Metformin hydrochloride

Metformin absorption is relatively slow and may extend over about 6 hours. Animal studies with metformin, labelled with ^{14}C have shown that the drug is neither concentrated by liver cells nor is it excreted in the bile; it is concentrated in the intestinal mucosa and salivary glands.

It has been shown that, following a 2 g dose of metformin, the blood level remains under 10 mcg/mL even at the peak, occurring 2 hours after absorption. During the experiments, metformin was shown to be devoid of any notable action in the body, apart from its specific metabolic activity.

In the healthy animal, metformin lowers blood sugar only at a nearly lethal dose. Different animal species are of unequal sensitivity. On the other hand, the animal with experimental diabetes, is sensitive to a much lower dosage, providing some insulin is still secreted.

The antihyperglycemic action of metformin is probably mediated through insulin:

Metformin improves the K co-efficient of glucose assimilation.

Metformin improves the co-efficient of insulin efficiency.

In the obese diabetic with hyperinsulinemia, metformin is reported to normalize insulin output. This normalizing effect is concurrent to that of glycemia.

Metformin has little effect on liver glycogen of the healthy animal. In low and average doses, no change occurs. In high doses nearing lethal levels, liver glycogen decreases. This lowering precedes the fall in blood sugar. This reaction represents a defense mechanism tending to mobilize body reserves in order to combat hypoglycemia.

In the diabetic animal with a low liver glycogen reserve, the opposite occurs and metformin builds up glycogen stores of the liver. *In vitro*, on muscular tissue isolated in Warburg's apparatus, metformin increases glucose uptake by the muscle. This action follows an aerobic pathway. Even in high concentration, contrary to phenethyl-biguanide, metformin apparently does not block respiration or change carbohydrate metabolism via the anaerobic pathway.

Metformin is eliminated in faeces and urine. It is rapidly excreted by the kidneys in an unchanged form.

Renal clearance is 450 mL/minute; this appears to explain the absence of accumulation.

Metabolites of metformin have not been identified, neither by radio-active nor by chemical methods.

A single Rf spot is always present following radiochromatographic study of urine and always corresponds to that of pure metformin. Administration during 10 consecutive days has not shown any sign of accumulation.

Inhibition of glyconeogenesis has been observed in animals following its stimulation by fasting, cortisol, alcohol or other substrates such as alanine lactate or pyruvate. However, such an effect varies according to the type and dosage of the biguanide used, nutritional state of the animal species and design of experimental model.

This inhibition of glyconeogenesis is observed only in the presence of insulin and it does not appear to play an important role in man.

Inhibition of intestinal absorption of sugars, which is not related to a malabsorption phenomenon has been observed with biguanides under certain experimental conditions in animal and in man. In one study, a 20% retardation of galactose absorption was observed in man receiving metformin. However, such an effect of metformin could not be confirmed in another study in man.

Recent findings appear to indicate that most of the metabolic effects of the biguanides are exerted through a single mechanism, namely inhibition of fatty acid oxidation and of acetyl-CoA generation.

However, inhibition of insulin-stimulated lipogenesis which has also been observed appears to be due to the inhibition of acetyl-CoA carboxylase by the biguanides. Such an effect may explain, at least partly, the weight-reducing effect exerted by these drugs in obese diabetic patients.

TOXICOLOGY

No animal studies have been conducted with the combined products in JANUMET[®] or JANUMET[®] XR to evaluate carcinogenesis, mutagenesis, impairment of fertility or effects on reproduction. The following data are based on the findings in studies with sitagliptin and metformin individually and a 16 week toxicity study in dogs with the concomitant administration of sitagliptin and metformin.

Acute Toxicity

Sitagliptin

The approximate LD₅₀ of sitagliptin given orally to rats is >3000 mg/kg (maximum dose tested). This dose is equivalent to ≥ 200 times the human exposure based on the recommended daily adult human dose of 100 mg/day. In mice the approximate oral LD₅₀ of sitagliptin is 4000 mg/kg. This dose is equivalent to >385 times the human exposure based on recommended daily adult human dose of 100 mg/day.

Chronic Toxicity

Sitagliptin and Metformin

Preclinical toxicokinetic and oral toxicity studies in dogs have been conducted with the combined products in JANUMET[®].

In a sixteen-week oral toxicity study, female dogs were administered 20 mg/kg/day of metformin, alone or in combination with 2, 10, or 50 mg/kg/day of sitagliptin. Transient ataxia and/or tremors were observed in the high-dose combination-treatment group. These signs were considered to be an effect of sitagliptin because they were seen in previous dog studies with sitagliptin alone at 50 mg/kg/day. The no-effect level for treatment-related changes in this study was 10 mg/kg/day of sitagliptin plus 20 mg/kg/day of metformin, which provided systemic exposure to sitagliptin of approximately 6 times that in patients treated with 100 mg/day of sitagliptin and systemic exposure to metformin of approximately 2.5 times that in patients treated with 2000 mg/day of metformin.

Sitagliptin

The toxicity potential of sitagliptin was evaluated in a series of repeated dose toxicity studies of up to 53 weeks in dogs and up to 27 weeks in rats. In dogs administered sitagliptin orally at dosages of 2, 10 and 50 mg/kg/day, the no-observed effect level was 10 mg/kg/day (up to 6 times the human exposure based on the recommended daily adult human dose of 100 mg/day).

Treatment-related physical signs observed in the 50 mg/kg/day group included open-mouth breathing, salivation, white foamy emesis, ataxia, trembling, decreased activity, and/or hunched posture. These signs were transient, slight in degree, and occurred with decreased incidence during the course of the study. In addition, very slight to slight skeletal muscle degeneration was observed histologically in the 14- and 27-week toxicity studies at the 50 mg/kg/day dose.

However, no skeletal muscle degeneration was found in the 53-week toxicity study, indicating the lack of reproducibility or progression of this change with increased duration of treatment.

The 50 mg/kg/day dose in dogs resulted in systemic exposure values 26 times the human exposure at the recommended daily adult human dose of 100 mg/day. In rats, sitagliptin administered orally at dosages of up to 180 mg/kg/day (up to 23 times the human exposure based on the recommended daily adult human dose of 100 mg/day), no significant toxicity was observed. The only drug-related effect observed was post-dose salivation, likely related to poor palatability of the drug, at doses of 60 mg/kg/day and 180 mg/kg/day.

The treatment-related changes noted in animals do not suggest any clinical concerns at the recommended therapeutic dosages in humans.

Carcinogenicity

Sitagliptin

A two-year carcinogenicity study was conducted in male and female rats given oral doses of sitagliptin of 50, 150, and 500 mg/kg/day. There was an increased incidence of hepatic adenomas and carcinomas in the high-dose males and hepatic carcinomas in the high-dose females. This dose in rats results in approximately 58 times the human exposure based on the recommended daily adult human dose of 100 mg/day. This dose level was associated with hepatotoxicity in rats. The no-observed effect level for induction of hepatic neoplasia was 150 mg/kg/day, approximately 19-fold the human exposure at the 100-mg recommended dose. Since hepatotoxicity has been shown to correlate with induction of hepatic neoplasia in rats, this increased incidence of hepatic tumors in rats was likely secondary to chronic hepatic toxicity at this high dose. The clinical significance of these findings for humans is unknown.

A two-year carcinogenicity study was conducted in male and female mice at oral doses of 50, 125, 250, and 500 mg/kg/day. Sitagliptin did not increase tumor incidence in mice in any organ at doses up to 500 mg/kg/day (approximately 68 times the human exposure based on the recommended daily adult human dose of 100 mg/day).

Metformin hydrochloride

Long-term carcinogenicity studies have been performed in rats (dosing duration of 104 weeks) and mice (dosing duration of 91 weeks) at doses up to and including 900 mg/kg/day and 1500 mg/kg/day, respectively. These doses are both approximately three times the maximum recommended human daily dose based on body surface area comparisons. No evidence of carcinogenicity with metformin was found in either male or female mice. Similarly, there was no tumorigenic potential observed with metformin in male rats. There was, however, an increased incidence of benign stromal uterine polyps in female rats treated with 900 mg/kg/day.

A carcinogenicity study was also conducted via dermal administration in Tg.AC transgenic mice at doses up to and including 2000 mg/kg/day. No evidence of carcinogenicity was observed in either male or female mice.

Mutagenesis

Sitagliptin

Sitagliptin was not mutagenic or clastogenic in a battery of genetic toxicology studies, including the Ames bacterial assay (microbial mutagenesis test), Chinese hamster ovary cells (CHO cells) chromosome aberration assay, an *in vitro* cytogenetics assay using CHO cells, an *in vitro* rat hepatocyte DNA alkaline elution assay (an assay which measures the compound's ability to induce single strand breaks in DNA), and an *in vivo* micronucleus assay.

Metformin hydrochloride

There was no evidence of a mutagenic potential of metformin in the following *in vitro* tests: Ames test (*S. typhimurium*), gene mutation test (mouse lymphoma cells), or chromosomal aberrations test (human lymphocytes). Results in the *in vivo* mouse micronucleus test were also negative.

Reproduction

Sitagliptin

No adverse effects upon fertility were observed in male and female rats given sitagliptin orally at doses up to 1000 mg/kg daily (up to approximately 100 times the human exposure based on the recommended daily adult human dose of 100 mg/day) prior to and throughout mating.

Metformin hydrochloride

Fertility of male or female rats was unaffected by metformin when administered at doses as high as 600 mg/kg/day, which is approximately three times the maximum recommended human daily dose based on body surface area comparisons.

A decrease in male reproductive organ weights was observed at higher oral dose of 900 mg/kg/day in a fertility and developmental toxicity study in rats.

Development

No animal studies have been conducted with the combined products in JANUMET[®] or JANUMET XR[®] to evaluate effects on reproduction. The following data are based on findings in studies performed with sitagliptin or metformin individually.

Sitagliptin

Sitagliptin was not teratogenic in rats at oral doses up to 250 mg/kg or in rabbits given up to 125 mg/kg during organogenesis (up to 32 and 22 times the human exposure based on the recommended daily adult human dose of 100 mg/day). A slight, treatment-related increased incidence of fetal rib malformations (absent, hypoplastic and wavy ribs) was observed in the offspring of rats at oral doses of 1000 mg/kg/day (approximately 100 times the human exposure based on the recommended daily adult human dose of 100 mg/day). The no-observed effect level for developmental effects was 250 mg/kg/day (32 times the human exposure based on the recommended daily adult human dose of 100 mg/day). Treatment-related decreases in the mean preweaning body weight of both sexes and postweaning body weight gain of male animals was observed in offspring of rats at oral doses of 1000 mg/kg.

Metformin hydrochloride

Metformin was not teratogenic in rats and rabbits at doses up to 600 mg/kg/day. This represents an exposure of about 2 times the maximum recommended human daily dose based on body surface area comparisons. Determination of fetal concentrations demonstrated a partial placental barrier to metformin.

REFERENCES

1. Canadian Diabetes Association Clinical Practice Guidelines Expert Committee. Canadian Diabetes Association 2013 Clinical Practice Guidelines for the Prevention and Management of Diabetes in Canada. *Can J Diabetes* 2013;37 (Suppl 1):S1-S212.
2. Charbonnel B, Karasik A, Liu J, Wu M, Meininger G. Efficacy and safety of the dipeptidyl peptidase-4 inhibitor sitagliptin added to ongoing metformin therapy in patients with type 2 diabetes inadequately controlled with metformin alone. *Diabetes Care* 2006;29(12):2638-43.
3. Drucker DJ. Development of glucagon-like peptide-1-based pharmaceuticals as therapeutic agents for the treatment of diabetes. *Curr Pharm Des* 2001;7(14):1399-412.
4. GLUCOPHAGE Product Monograph, Sanofi-Aventis Canada Inc.
5. Hanefeld M, Herman GA, Wu M, Mickel C, Sanchez M, Stein PP. Once-daily sitagliptin, a dipeptidyl peptidase-4 inhibitor, for the treatment of patients with type 2 diabetes. *Cur Med Res & Opinions* 2007; 23(6): 1329-1339.
6. Nauck MA, Meininger G, Sheng D, Terranella L, Stein PP. Efficacy and safety of the dipeptidyl peptidase-4 inhibitor, sitagliptin, compared with the sulfonylurea, glipizide, in patients with type 2 diabetes inadequately controlled on metformin alone: a randomized, double-blind, non-inferiority trial. *Diabetes Obes Metab* 2007;9(2):194-205.
7. Williams-Herman D, Engel SS, Round E, Johnson J, Golm GT et al. Safety and tolerability of sitagliptin in clinical studies: a pooled analysis of data from 10,246 patients with type 2 diabetes. *BMC Endocr Disord* 2010;10(7) (<http://www.biomedcentral.com/1472-6823/10/7>)
8. Hermansen K, Kipnes M, Luo E, Fanurik D, Khatami H, Stein P for the Sitagliptin Study 035 Group. Efficacy and safety of the dipeptidyl peptidase-4 inhibitor, sitagliptin, in patients with type 2 diabetes mellitus inadequately controlled on glimepiride alone or on glimepiride and metformin. *Diabetes Obes Metab* 2007; 9:733-745.
9. Vilsbøll T, Rosenstock J, Yki-Järvinen H, Cefalu WT, Chen Y, Luo E, et al. Efficacy and safety of sitagliptin when added to insulin therapy in patients with type 2 diabetes. *Diabetes Obes Metab* 2010;12:167-77.
10. Green JB, Bethel MA, Armstrong PW, Buse JB et al. Effect of sitagliptin on cardiovascular outcomes in type 2 diabetes. *N Engl J Med* 2015;373: 232-42.

PART III: CONSUMER INFORMATION**JANUMET®**

sitagliptin and metformin hydrochloride tablets
(as sitagliptin phosphate monohydrate and metformin hydrochloride)

JANUMET® XR

sitagliptin and metformin hydrochloride modified-release tablets
(as sitagliptin phosphate monohydrate and metformin hydrochloride)

This leaflet is Part III of a three-part “Product Monograph” published when JANUMET® and JANUMET® XR was approved for sale in Canada and is designed specifically for Consumers. This leaflet is a summary and will not tell you everything about JANUMET® and JANUMET® XR. Contact your physician or pharmacist if you have any questions about the drug.

ABOUT THIS MEDICATIONWhat the medication is used for:

JANUMET® or JANUMET® XR are used in addition to diet and exercise to improve blood sugar levels in patients with type 2 diabetes mellitus

- Alone, in patients who are not controlled on metformin alone or currently on sitagliptin and metformin; OR
- In combination with a sulfonylurea, in patients who are not controlled on metformin and a sulfonylurea.
- JANUMET® or JANUMET® XR can be taken with premixed or long/intermediate acting insulin.
- In combination with pioglitazone, in patients who are not controlled on metformin and pioglitazone.

What it does:

JANUMET® and JANUMET® XR are a tablet that contains sitagliptin and metformin. These two medicines work together to help you achieve better blood sugar control.

Sitagliptin is a member of a class of medicines called DPP-4 inhibitors (dipeptidyl peptidase-4 inhibitors). Sitagliptin helps to improve the levels of insulin when blood sugar level is high, especially after a meal. Sitagliptin also helps to decrease the amount of sugar made by the body. Sitagliptin is unlikely to cause low blood sugar (**hypoglycemia**).

Metformin is a member of the biguanide class of medicines, it helps to lower the amount of sugar made by the liver. Together, these medicines help you to achieve better blood sugar control.

What is type 2 diabetes?

Type 2 diabetes is a condition in which your body does not make enough insulin, and/or does not use the insulin that your body

produces as well as it should. When this happens, sugar (glucose) builds up in the blood. This can lead to serious problems.

When it should not be used:

Do not take JANUMET® or JANUMET® XR if you:

- Have unstable and/or insulin-dependent (type 1) diabetes mellitus.
- Have metabolic acidosis (including diabetic ketoacidosis, history or ketoacidosis or lactic acidosis – too much acid in the blood).
- Have severe kidney disease.
- Have liver problems.
- Drink alcohol very often or drink a lot of alcohol in the short term (“binge” drinking).
- Have severe heart problems or heart failure.
- Have a lack of oxygen in the blood. This is called hypoxemia. This can happen when you have conditions that affect your heart or breathing.
- Are stressed, have severe infections, are experiencing trauma, are about to have surgery, or are recovering from surgery.
- Have severe **dehydration** (have lost a lot of water from your body) or shock.
- Are allergic to sitagliptin, metformin, or any of the ingredients in JANUMET® or JANUMET® XR. See “What the non-medicinal ingredients are”.
- Are breastfeeding.
- Are pregnant or planning to become pregnant.
- Are going to get or receive an injection of dye or contrast agent for an x-ray procedure. Talk to your physician or pharmacist about when to stop JANUMET® or JANUMET® XR and when to start again.

What the medicinal ingredients are:

Sitagliptin phosphate monohydrate and metformin hydrochloride

What the non-medicinal ingredients are:

Each film-coated tablet of JANUMET® contains the following inactive ingredients: microcrystalline cellulose, polyvinylpyrrolidone, sodium lauryl sulfate, and sodium stearyl fumarate. In addition, the film coating contains the following inactive ingredients: polyvinyl alcohol, polyethylene glycol, talc, titanium dioxide, red iron oxide, and black iron oxide.

Each modified-release tablet of JANUMET® XR contains the following inactive ingredients: colloidal silicon dioxide, hypromellose, kaolin, polyethylene glycol, povidone, propyl gallate, and sodium stearyl fumarate. The JANUMET® XR 50 mg/500 mg tablet contains the additional inactive ingredient microcrystalline cellulose. In addition, the film coating contains the following inactive ingredients: hypromellose, hydroxypropyl cellulose, titanium dioxide, FD&C Blue #2/Indigo Carmine Aluminum Lake and carnauba wax. The JANUMET® XR 50 mg/1000 mg tablet contains the additional inactive ingredient yellow iron oxide.

What dosage forms it comes in:

JANUMET® tablets contain sitagliptin/metformin hydrochloride 50 mg/500 mg, 50 mg/850 mg, or 50 mg/1000 mg.

JANUMET® XR tablets contain immediate release sitagliptin (as sitagliptin phosphate monohydrate) /extended-release metformin hydrochloride 50 mg/500 mg, 50 mg/1000 mg or 100 mg/1000 mg.

WARNINGS AND PRECAUTIONS

Serious Warnings and Precautions

Lactic acidosis is a rare but serious buildup of acid in the blood. It can cause death. It must be treated in the hospital. JANUMET® or JANUMET® XR contains a drug called metformin hydrochloride. If you build up too much metformin in your blood you are at risk for lactic acidosis.

Alcohol increases the risk of lactic acidosis caused by metformin. Do not “binge” drink or drink alcohol often when you are taking JANUMET® or JANUMET® XR.

Lactic Acidosis

Stop taking JANUMET® or JANUMET® XR if you get the following symptoms of lactic acidosis:

- You feel very weak and tired.
- You have unusual (not normal) muscle pain.
- You have trouble breathing.
- You have stomach pain with nausea and vomiting, or diarrhea.
- You feel cold, especially in your arms and legs.
- You feel dizzy or lightheaded.
- You have a slow or irregular heartbeat.
- Your medical condition suddenly changes.

You have a higher chance of getting lactic acidosis if you:

- have severe kidney problems. Your kidneys can be affected by certain x-ray tests that use injected dye. JANUMET® or JANUMET® XR is usually stopped before and for two days after such a test. Your doctor should discuss this with you;
- have liver problems
- have congestive heart failure that requires treatment with medicines;
- drink a lot of alcohol (very often or short-term “binge” drinking);
- get **dehydration** (lose a large amount of body fluids). This can happen if you are sick with a fever, vomiting, or diarrhea. Dehydration can also happen when you sweat a lot with activity or exercise and don’t drink enough fluids;
- have certain x-ray tests with injectable dyes or contrast agents used;
- have surgery. Talk with your doctor before any surgery if you must restrict what you eat and drink. In these cases, JANUMET® or JANUMET® XR should be stopped for 2 days before the surgery. Wait until you are eating and

drinking again before you restart JANUMET® or JANUMET® XR. You doctor should discuss this with you;

- have a heart attack, severe infection, or stroke;
- take other medications;

BEFORE or while taking JANUMET® or JANUMET® XR talk to your physician or pharmacist if:

- you are older than 65 years of age;
- you have or have had pancreatitis (inflammation of the pancreas);
- you have risk factors for pancreatitis such as:
 - gallstones (solid particles that form in the gall bladder),
 - a history of alcoholism,
 - high triglyceride levels;
- you are receiving treatment with insulin or are taking a sulfonylurea. When JANUMET® or JANUMET® XR is used in combination with sulfonylurea or insulin, low blood sugar can occur. Your physician may consider lowering the dose of the sulfonylurea or insulin. Take precautions to avoid low blood sugar while driving or using machinery;
- you have heart problems including congestive heart failure (a condition where your heart becomes weaker and less able to pump the blood that your body needs);
- you have or have had severe kidney problems;
- you have liver problems;
- you had an organ transplant;
- you have human immunodeficiency syndrome (HIV);
- you have vitamin B₁₂ deficiency or anemia;
- you have hypothyroidism (low levels of thyroid hormones).

JANUMET® and JANUMET® XR are not recommended for use in patients under 18 years of age.

JANUMET® and JANUMET® XR may cause abnormal kidney function.

Cases of inflammation of the pancreas (**pancreatitis**) have been reported in patients taking JANUMET® or JANUMET® XR. Pancreatitis can be severe and lead to death.

Cases of **serious skin reactions** can occur and have been reported in patients taking JANUMET® or JANUMET® XR. These skin reactions are called **Stevens-Johnson syndrome** and **bullous pemphigoid**. They can happen after the first dose or up to 3 months on the drug. You may need treatment in a hospital. You may need to see a dermatologist to diagnose and treat these skin reactions.

INTERACTIONS WITH THIS MEDICATION

Tell your healthcare professional about all the medicines you take, including any drugs, vitamins, minerals, natural supplements, or alternative medicines.

If you start any new medicine, tell your healthcare professional.

The following may interact with JANUMET® or JANUMET® XR:

- Other diabetes drugs such as glyburide.
- Furosemide.
- Nifedipine (used to treat high blood pressure and chest pain).
- Drugs that decrease the rate of elimination of metformin from your body (e.g., ranolazine, vandetanib, dolutegravir and cimetidine).
- Certain “blood thinners” (phenprocoumon or other antivitamin K anticoagulants).
- Other drugs that tend to produce high blood sugar (hyperglycemia) and may lead to a loss of blood sugar control. Some example of drugs that can increase the blood sugar include:
 - Thiazide and other diuretics (water pills)
 - Corticosteroids (used to treat joint pain and swelling)
 - Phenothiazines (used to treat schizophrenia)
 - Thyroid products
 - Estrogens or estrogens plus progestogen
 - Oral contraceptives (birth control pills)
 - Phenytoin (used to treat epilepsy)
 - Nicotinic Acid
 - Sympathomimetics (used for heart problems)
 - Calcium channel blocking drugs (used for high blood pressure)
 - Isoniazid (used to treat tuberculosis)
 - Beta-2-agonists (used to treat breathing problems)
 - Carbonic anhydrase inhibitors
- ACE inhibitors drugs may lower blood glucose and the combination with JANUMET® or JANUMET® XR should be carefully monitored.

PROPER USE OF THIS MEDICATION

Your doctor will individualize your starting dose of JANUMET® or JANUMET® XR based on your current treatment regimen. Take JANUMET® or JANUMET® XR exactly as your physician has prescribed. Your physician will tell you how many JANUMET® or JANUMET® XR tablets to take and how often you should take them.

Your physician may adjust your dose, if needed to further control your blood sugar level.

Usual adult dose:

JANUMET® should be given 2 times a day by mouth with a meal to lower your chance of an upset stomach.

JANUMET® XR should be taken once a day with food preferably in the evening to lower your chance of an upset stomach.

If you take JANUMET® XR, swallow the JANUMET® XR tablets whole. Do not chew, cut, or crush the tablets. Tell your doctor if you cannot swallow JANUMET® XR whole.

You may see something that looks like the JANUMET® XR tablet in your stool (bowel movement). If this happens, check your blood sugar. If your blood sugar control has changed, contact your doctor. Do not stop taking JANUMET® XR without talking to your doctor.

Continue to take JANUMET® or JANUMET® XR as long as your physician prescribes it so you can continue to help control your blood sugar.

You may need to stop JANUMET® or JANUMET® XR for a short time. Call your physician for instructions if you:

- have a condition that may be associated with dehydration (large loss of body fluids) such as being sick with severe vomiting, diarrhea or fever, or if you drink fluids a lot less than normal;
- plan to have surgery;
- are going to get or receive an injection of dye or contrast agent for an x-ray procedure.

Overdose:

If you think you have taken too much JANUMET® or JANUMET® XR, contact your healthcare professional, hospital emergency department or regional Poison Control Centre immediately, even if there are no symptoms.

Missed Dose:

If you miss a dose, take it with food as soon as you remember. If you do not remember until it is time for your next dose, skip the missed dose and go back to your regular schedule. Do not take two doses of JANUMET® or JANUMET® XR at the same time.

SIDE EFFECTS AND WHAT TO DO ABOUT THEM

These are not all the possible side effects that you may have when taking JANUMET® or JANUMET® XR. If you experience any side effects not listed here, contact your healthcare professional.

Side effects of JANUMET® or JANUMET® XR include:

- Stuffy or runny nose
- Sore throat
- Gastrointestinal symptoms: diarrhea, constipation, nausea, vomiting, abdominal bloating, upset stomach, gas and loss of appetite
- Headache
- Joint pain
- Arm or leg pain
- Back pain
- Muscle aches
- Itching
- Blisters

When JANUMET® or JANUMET® XR is used with a sulfonylurea medicine or with insulin, low blood sugar (hypoglycemia) can occur. Lower doses of the sulfonylurea medicine or insulin may be required while you used JANUMET® or JANUMET® XR.

JANUMET® or JANUMET® XR can cause abnormal blood test results. Your doctor will do blood tests before you start JANUMET® or JANUMET® XR and while you take it. They may check your blood sugar, liver and thyroid function, amount of vitamin B₁₂ and how well your kidneys are working. Your doctor will decide when to perform blood tests and will interpret the results.

SERIOUS SIDE EFFECTS, HOW OFTEN THEY HAPPEN AND WHAT TO DO ABOUT THEM			
Symptoms / Effects	Talk with your physician or pharmacist		Stop taking drug and call your physician or pharmacist
	Only if severe	In all cases	
Very common			
Hypoglycemia (low blood sugar - when used with a sulfonylurea or with insulin): shaking, sweating, rapid heartbeat, change in vision, hunger, headache and change in mood.		✓	
Rare			
Pancreatitis (inflammation of the pancreas): prolonged severe stomach pain and possible vomiting			✓
Allergic reactions: rash, hives, and swelling of the face, lips, tongue, and throat that may cause difficulty in breathing or swallowing.			✓
Serious skin reactions including Stevens-Johnson syndrome, bullous pemphigoid: blisters or breakdown of your skin.		✓	
Lactic acidosis (buildup of lactic acid in the blood): malaise or a feeling of general discomfort, uneasiness or pain; feeling very weak or tired; sleepiness, drowsiness or an increasing strong desire for sleep; low blood pressure, dizziness, lightheadedness; cold hands or feet; slow or irregular heartbeat, trouble breathing; unusual muscle pain; stomach pain with nausea, vomiting, or diarrhea.			✓
Encephalopathy (disease of the brain that severely alters thinking): muscle weakness in one area, poor decision-making or concentration, involuntary twitching, trembling, difficulty speaking or swallowing, seizures.			✓

SERIOUS SIDE EFFECTS, HOW OFTEN THEY HAPPEN AND WHAT TO DO ABOUT THEM			
Symptoms / Effects	Talk with your physician or pharmacist		Stop taking drug and call your physician or pharmacist
	Only if severe	In all cases	
Lowering of Thyroid Stimulating hormone level in patients with low thyroid function: fatigue, feeling cold, dry skin, poor memory and concentration, weight gain.		✓	
Acute kidney failure (sometimes requiring dialysis): nausea, loss of appetite and weakness, pass little or no urine, breathlessness.			✓
Hemolytic anemia (when red blood cells are destroyed faster than bone marrow can replace them): fatigue, pale color, rapid heartbeat, shortness of breath, dark urine, chills, and backache.			✓
Peripheral neuropathy (a result of damage to your peripheral nerves): gradual onset of numbness, prickling or tingling in your feet or hands, which can spread upward into your legs and arms, sharp, jabbing, throbbing, freezing or burning pain, extreme sensitivity to touch, lack of coordination and falling, muscle weakness or paralysis if motor nerves are affected.			✓
Very rare			
Vitamin B₁₂ deficiency (decreased vitamin B₁₂ levels in the blood): fatigue, shortness of breath, tingling or numbness of the fingers or toes, difficulty walking properly, irritability, confusion, tender calves.		✓	
Hepatitis (inflammation of the liver) or liver disorder: yellow of the skin or eyes, dark urine, abdominal pain, nausea, vomiting, loss of appetite.		✓	

If you have a troublesome symptom or side effect that is not listed here or becomes bad enough to interfere with your daily activities, talk to your healthcare professional.

HOW TO STORE IT

The product should be stored at 15°C to 30°C.

Keep out of reach and sight of children.

Reporting Side Effects

You can report any suspected side effects associated with the use of health products to Health Canada by.

- Visiting the Web page on Adverse Reaction Reporting (<https://www.canada.ca/en/health-canada/services/drugs-health-products/medeffect-canada/adverse-reaction-reporting.html>) for information on how to report online, by mail or by fax; or
- Calling toll-free at 1-866-234-2345.

NOTE: Contact your health professional if you need information about how to manage your side effects. The Canada Vigilance Program does not provide medical advice.

MORE INFORMATION**If you want more information about****JANUMET®/JANUMET® XR:**

- Talk to your healthcare professional
- Find the full product monograph that is prepared for healthcare professionals and includes this Consumer Information by visiting the [Health Canada website](#) or Merck Canada website www.merck.ca or by calling Merck Canada at 1-800-567-2594.

To report an adverse event related to JANUMET®/JANUMET® XR, please contact 1-800-567-2594.

This leaflet was prepared by Merck Canada Inc.

Last revised: December 18, 2019

® Merck Sharp & Dohme Corp. Used under license.

© 2011, 2019 Merck Canada Inc. All rights reserved.

HIGHLIGHTS OF PRESCRIBING INFORMATION

These highlights do not include all the information needed to use JANUMET safely and effectively. See full prescribing information for JANUMET.

JANUMET® (sitagliptin and metformin hydrochloride) tablets, for oral use

Initial U.S. Approval: 2007

WARNING: LACTIC ACIDOSIS

See full prescribing information for complete boxed warning.

- Postmarketing cases of metformin-associated lactic acidosis have resulted in death, hypothermia, hypotension, and resistant bradyarrhythmias. Symptoms included malaise, myalgias, respiratory distress, somnolence, and abdominal pain. Laboratory abnormalities included elevated blood lactate levels, anion gap acidosis, increased lactate/pyruvate ratio, and metformin plasma levels generally >5 mcg/mL. (5.1)
- Risk factors include renal impairment, concomitant use of certain drugs, age ≥65 years old, radiological studies with contrast, surgery and other procedures, hypoxic states, excessive alcohol intake, and hepatic impairment. Steps to reduce the risk of and manage metformin-associated lactic acidosis in these high risk groups are provided in the Full Prescribing Information. (5.1)
- If lactic acidosis is suspected, discontinue JANUMET and institute general supportive measures in a hospital setting. Prompt hemodialysis is recommended. (5.1)

INDICATIONS AND USAGE

JANUMET is a combination of sitagliptin, a dipeptidyl peptidase-4 (DPP-4) inhibitor, and metformin hydrochloride (HCl), a biguanide, indicated as an adjunct to diet and exercise to improve glycemic control in adults with type 2 diabetes mellitus. (1)

Limitations of Use:

- JANUMET should not be used in patients with type 1 diabetes or for the treatment of diabetic ketoacidosis. (1)
- JANUMET has not been studied in patients with a history of pancreatitis. (1, 5.2)

DOSAGE AND ADMINISTRATION

- Individualize the starting dose of JANUMET based on the patient's current regimen. (2.1)
- Adjust the dosing based on effectiveness and tolerability while not exceeding the maximum recommended daily dose of 100 mg sitagliptin and 2000 mg metformin. (2.1)
- Give twice daily with meals, with gradual dose escalation, to reduce the gastrointestinal effects due to metformin. (2.1)
- Prior to initiation, assess renal function with estimated glomerular filtration rate (eGFR) (2.2)
 - Do not use in patients with eGFR below 30 mL/min/1.73 m².
 - JANUMET is not recommended in patients with eGFR between 30 and less than 45 mL/min/1.73 m².
- JANUMET may need to be discontinued at time of, or prior to, iodinated contrast imaging procedures. (2.3)

DOSAGE FORMS AND STRENGTHS

Tablets: 50 mg sitagliptin/500 mg metformin HCl and 50 mg sitagliptin/1000 mg metformin HCl (3)

CONTRAINDICATIONS

- Severe renal impairment: (eGFR below 30 mL/min/1.73 m²) (4)
- Metabolic acidosis, including diabetic ketoacidosis. (4)
- History of a serious hypersensitivity reaction to JANUMET, sitagliptin, or metformin, such as anaphylaxis or angioedema. (5.9, 6.2)

WARNINGS AND PRECAUTIONS

- Lactic acidosis: See boxed warning. (5.1)
- There have been postmarketing reports of acute pancreatitis, including fatal and non-fatal hemorrhagic or necrotizing pancreatitis. If pancreatitis is suspected, promptly discontinue JANUMET. (5.2)
- Heart failure has been observed with two other members of the DPP-4 inhibitor class. Consider risks and benefits of JANUMET in

patients who have known risk factors for heart failure. Monitor patients for signs and symptoms. (5.3)

- There have been postmarketing reports of acute renal failure, sometimes requiring dialysis. Before initiating JANUMET and at least annually thereafter, assess renal function. (5.4)
- Vitamin B₁₂ deficiency: Metformin may lower vitamin B₁₂ levels. Measure hematologic parameters annually. (5.5)
- When used with an insulin secretagogue (e.g., sulfonylurea) or with insulin, a lower dose of the insulin secretagogue or insulin may be required to reduce the risk of hypoglycemia. (5.7)
- There have been postmarketing reports of serious allergic and hypersensitivity reactions in patients treated with sitagliptin (one of the components of JANUMET), such as anaphylaxis, angioedema, and exfoliative skin conditions including Stevens-Johnson syndrome. In such cases, promptly stop JANUMET, assess for other potential causes, institute appropriate monitoring and treatment, and initiate alternative treatment for diabetes. (5.9)
- Severe and disabling arthralgia has been reported in patients taking DPP-4 inhibitors. Consider as a possible cause for severe joint pain and discontinue drug if appropriate. (5.10)
- There have been postmarketing reports of bullous pemphigoid requiring hospitalization in patients taking DPP-4 inhibitors. Tell patients to report development of blisters or erosions. If bullous pemphigoid is suspected, discontinue JANUMET. (5.11)
- There have been no clinical studies establishing conclusive evidence of macrovascular risk reduction with JANUMET. (5.12)

ADVERSE REACTIONS

- The most common adverse reactions reported in ≥5% of patients simultaneously started on sitagliptin and metformin and more commonly than in patients treated with placebo were diarrhea, upper respiratory tract infection, and headache. (6.1)
- Adverse reactions reported in ≥5% of patients treated with sitagliptin in combination with sulfonylurea and metformin and more commonly than in patients treated with placebo in combination with sulfonylurea and metformin were hypoglycemia and headache. (6.1)
- Hypoglycemia was the only adverse reaction reported in ≥5% of patients treated with sitagliptin in combination with insulin and metformin and more commonly than in patients treated with placebo in combination with insulin and metformin. (6.1)

To report SUSPECTED ADVERSE REACTIONS, contact Merck Sharp & Dohme Corp., a subsidiary of Merck & Co., Inc., at 1-877-888-4231 or FDA at 1-800-FDA-1088 or www.fda.gov/medwatch.

DRUG INTERACTIONS

- Carbonic anhydrase inhibitors may increase risk of lactic acidosis. Consider more frequent monitoring. (7.1)
- Drugs that reduce metformin clearance (such as ranolazine, vandetanib, dolutegravir, and cimetidine) may increase the accumulation of metformin. Consider the benefits and risks of concomitant use. (7.2)
- Alcohol can potentiate the effect of metformin on lactate metabolism. Warn patients against excessive alcohol intake. (7.3)

USE IN SPECIFIC POPULATIONS

- There are no adequate and well-controlled studies in pregnant women. To report drug exposure during pregnancy call 1-800-986-8999. (8.1)
- Geriatric Use: Assess renal function more frequently. (8.5)
- Hepatic Impairment: Avoid use in patients with hepatic impairment. (8.7)

See 17 for PATIENT COUNSELING INFORMATION and Medication Guide.

Revised: 8/2019

FULL PRESCRIBING INFORMATION: CONTENTS*

WARNING: LACTIC ACIDOSIS

1 INDICATIONS AND USAGE

2 DOSAGE AND ADMINISTRATION

- 2.1 Recommended Dosing
- 2.2 Recommendations for Use in Renal Impairment
- 2.3 Discontinuation for Iodinated Contrast Imaging Procedures

3 DOSAGE FORMS AND STRENGTHS

4 CONTRAINDICATIONS

5 WARNINGS AND PRECAUTIONS

- 5.1 Lactic Acidosis
- 5.2 Pancreatitis
- 5.3 Heart Failure
- 5.4 Assessment of Renal Function
- 5.5 Vitamin B₁₂ Deficiency
- 5.6 Change in Clinical Status of Patients with Previously Controlled Type 2 Diabetes
- 5.7 Use with Medications Known to Cause Hypoglycemia
- 5.8 Loss of Control of Blood Glucose
- 5.9 Hypersensitivity Reactions
- 5.10 Severe and Disabling Arthralgia
- 5.11 Bullous Pemphigoid
- 5.12 Macrovascular Outcomes

6 ADVERSE REACTIONS

- 6.1 Clinical Trials Experience
- 6.2 Postmarketing Experience

7 DRUG INTERACTIONS

- 7.1 Carbonic Anhydrase Inhibitors
- 7.2 Drugs that Reduce Metformin Clearance
- 7.3 Alcohol
- 7.4 Insulin Secretagogues or Insulin
- 7.5 Use of Metformin with Other Drugs
- 7.6 Digoxin

8 USE IN SPECIFIC POPULATIONS

- 8.1 Pregnancy
- 8.2 Lactation
- 8.3 Females and Males of Reproductive Potential
- 8.4 Pediatric Use
- 8.5 Geriatric Use
- 8.6 Renal Impairment
- 8.7 Hepatic Impairment

10 OVERDOSAGE

11 DESCRIPTION

12 CLINICAL PHARMACOLOGY

- 12.1 Mechanism of Action
- 12.2 Pharmacodynamics
- 12.3 Pharmacokinetics

13 NONCLINICAL TOXICOLOGY

- 13.1 Carcinogenesis, Mutagenesis, Impairment of Fertility

14 CLINICAL STUDIES

16 HOW SUPPLIED/STORAGE AND HANDLING

17 PATIENT COUNSELING INFORMATION

*Sections or subsections omitted from the full prescribing information are not listed.

FULL PRESCRIBING INFORMATION

WARNING: LACTIC ACIDOSIS

Postmarketing cases of metformin-associated lactic acidosis have resulted in death, hypothermia, hypotension, and resistant bradyarrhythmias. The onset of metformin-associated lactic acidosis is often subtle, accompanied only by nonspecific symptoms such as malaise, myalgias, respiratory distress, somnolence, and abdominal pain. Metformin-associated lactic acidosis was characterized by elevated blood lactate levels (>5 mmol/Liter), anion gap acidosis (without evidence of ketonuria or ketonemia), an increased lactate/pyruvate ratio, and metformin plasma levels generally >5 mcg/mL [see *Warnings and Precautions (5.1)*].

Risk factors for metformin-associated lactic acidosis include renal impairment, concomitant use of certain drugs (e.g., carbonic anhydrase inhibitors such as topiramate), age 65 years old or greater, having a radiological study with contrast, surgery and other procedures, hypoxic states (e.g., acute congestive heart failure), excessive alcohol intake, and hepatic impairment.

Steps to reduce the risk of and manage metformin-associated lactic acidosis in these high risk groups are provided in the full prescribing information [see *Dosage and Administration (2.2)*, *Contraindications (4)*, *Warnings and Precautions (5.1)*, *Drug Interactions (7)*, and *Use in Specific Populations (8.6, 8.7)*].

If metformin-associated lactic acidosis is suspected, immediately discontinue JANUMET and institute general supportive measures in a hospital setting. Prompt hemodialysis is recommended [see *Warnings and Precautions (5.1)*].

1 INDICATIONS AND USAGE

JANUMET is indicated as an adjunct to diet and exercise to improve glycemic control in adults with type 2 diabetes mellitus.

Limitations of Use

JANUMET should not be used in patients with type 1 diabetes mellitus or for the treatment of diabetic ketoacidosis.

JANUMET has not been studied in patients with a history of pancreatitis. It is unknown whether patients with a history of pancreatitis are at increased risk for the development of pancreatitis while using JANUMET. [See *Warnings and Precautions (5.2)*.]

2 DOSAGE AND ADMINISTRATION

2.1 Recommended Dosing

The dosage of JANUMET should be individualized on the basis of the patient's current regimen, effectiveness, and tolerability while not exceeding the maximum recommended daily dose of 100 mg sitagliptin and 2000 mg metformin hydrochloride (HCl). Initial combination therapy or maintenance of combination therapy should be individualized and left to the discretion of the health care provider.

JANUMET should generally be given twice daily with meals, with gradual dose escalation, to reduce the gastrointestinal (GI) side effects due to metformin. JANUMET must not be split or divided before swallowing.

The starting dose of JANUMET should be based on the patient's current regimen. JANUMET should be given twice daily with meals. The following doses are available:

50 mg sitagliptin/500 mg metformin HCl

50 mg sitagliptin/1000 mg metformin HCl.

The recommended starting dose in patients not currently treated with metformin is 50 mg sitagliptin/500 mg metformin HCl twice daily, with gradual dose escalation recommended to reduce gastrointestinal side effects associated with metformin.

The starting dose in patients already treated with metformin should provide sitagliptin dosed as 50 mg twice daily (100 mg total daily dose) and the dose of metformin already being taken. For patients taking metformin 850 mg twice daily, the recommended starting dose of JANUMET is 50 mg sitagliptin/1000 mg metformin HCl twice daily.

No studies have been performed specifically examining the safety and efficacy of JANUMET in patients previously treated with other oral antihyperglycemic agents and switched to JANUMET. Any change in therapy of type 2 diabetes should be undertaken with care and appropriate monitoring as changes in glycemic control can occur.

2.2 Recommendations for Use in Renal Impairment

Assess renal function prior to initiation of JANUMET and periodically thereafter.

JANUMET is contraindicated in patients with an estimated glomerular filtration rate (eGFR) below 30 mL/min/1.73 m² [see *Contraindications (4) and Warnings and Precautions (5.1)*].

JANUMET is not recommended in patients with an eGFR between 30 and less than 45 mL/min/1.73 m² because these patients require a lower dosage of sitagliptin than what is available in the fixed combination JANUMET product.

2.3 Discontinuation for Iodinated Contrast Imaging Procedures

Discontinue JANUMET at the time of, or prior to, an iodinated contrast imaging procedure in patients with an eGFR between 30 and 60 mL/min/1.73 m²; in patients with a history of liver disease, alcoholism, or heart failure; or in patients who will be administered intra-arterial iodinated contrast. Re-evaluate eGFR 48 hours after the imaging procedure; restart JANUMET if renal function is stable [see *Warnings and Precautions (5.1)*].

3 DOSAGE FORMS AND STRENGTHS

Tablets:

- 50 mg/500 mg tablets are light pink, capsule-shaped, film-coated tablets with “575” debossed on one side.
- 50 mg/1000 mg tablets are red, capsule-shaped, film-coated tablets with “577” debossed on one side.

4 CONTRAINDICATIONS

JANUMET is contraindicated in patients with:

- Severe renal impairment (eGFR below 30 mL/min/1.73 m²) [see *Warnings and Precautions (5.1)*].
- Acute or chronic metabolic acidosis, including diabetic ketoacidosis. Diabetic ketoacidosis should be treated with insulin.
- History of a serious hypersensitivity reaction to JANUMET, sitagliptin, or metformin, such as anaphylaxis or angioedema. [See *Warnings and Precautions (5.9)*; *Adverse Reactions (6.2)*].

5 WARNINGS AND PRECAUTIONS

5.1 Lactic Acidosis

There have been postmarketing cases of metformin-associated lactic acidosis, including fatal cases. These cases had a subtle onset and were accompanied by nonspecific symptoms such as malaise, myalgias, abdominal pain, respiratory distress, or increased somnolence; however, hypothermia, hypotension and resistant bradyarrhythmias have occurred with severe acidosis. Metformin-associated lactic acidosis was characterized by elevated blood lactate concentrations (>5 mmol/Liter), anion gap acidosis (without evidence of ketonuria or ketonemia), and an increased lactate/pyruvate ratio; metformin plasma levels were generally >5 mcg/mL. Metformin decreases liver uptake of lactate increasing lactate blood levels which may increase the risk of lactic acidosis, especially in patients at risk.

If metformin-associated lactic acidosis is suspected, general supportive measures should be instituted promptly in a hospital setting, along with immediate discontinuation of JANUMET. In JANUMET-treated patients with a diagnosis or strong suspicion of lactic acidosis, prompt hemodialysis is recommended to correct the acidosis and remove accumulated metformin (metformin HCl is dialyzable, with a clearance of up to 170 mL/min under good hemodynamic conditions). Hemodialysis has often resulted in reversal of symptoms and recovery.

Educate patients and their families about the symptoms of lactic acidosis and if these symptoms occur instruct them to discontinue JANUMET and report these symptoms to their health care provider.

For each of the known and possible risk factors for metformin-associated lactic acidosis, recommendations to reduce the risk of and manage metformin-associated lactic acidosis are provided below:

Renal Impairment

The postmarketing metformin-associated lactic acidosis cases primarily occurred in patients with significant renal impairment. The risk of metformin accumulation and metformin-associated lactic acidosis increases with the severity of renal impairment because metformin is substantially excreted by the kidney. Clinical recommendations based upon the patient's renal function include [see *Dosage and Administration (2.2)*, *Clinical Pharmacology (12.3)*]:

- Before initiating JANUMET, obtain an estimated glomerular filtration rate (eGFR).
- JANUMET is contraindicated in patients with an eGFR below 30 mL/min/1.73 m² [see *Contraindications (4)*].
- JANUMET is not recommended in patients with an eGFR between 30 and less than 45 mL/min/1.73 m² because these patients require a lower dosage of sitagliptin than what is available in the fixed combination JANUMET product.
- Obtain an eGFR at least annually in all patients taking JANUMET. In patients at increased risk for the development of renal impairment (e.g., the elderly), renal function should be assessed more frequently.

Drug Interactions

The concomitant use of JANUMET with specific drugs may increase the risk of metformin-associated lactic acidosis: those that impair renal function, result in significant hemodynamic change, interfere with acid-base balance or increase metformin accumulation [see *Drug Interactions (7)*]. Therefore, consider more frequent monitoring of patients.

Age 65 or Greater

The risk of metformin-associated lactic acidosis increases with the patient's age because elderly patients have a greater likelihood of having hepatic, renal, or cardiac impairment than younger patients. Assess renal function more frequently in elderly patients [see *Use in Specific Populations (8.5)*].

Radiological Studies with Contrast

Administration of intravascular iodinated contrast agents in metformin-treated patients has led to an acute decrease in renal function and the occurrence of lactic acidosis. Stop JANUMET at the time of, or prior to, an iodinated contrast imaging procedure in patients with an eGFR between 30 and 60 mL/min/1.73 m²; in patients with a history of hepatic impairment, alcoholism, or heart failure; or in patients who will be administered intra-arterial iodinated contrast. Re-evaluate eGFR 48 hours after the imaging procedure, and restart JANUMET if renal function is stable.

Surgery and Other Procedures

Withholding of food and fluids during surgical or other procedures may increase the risk for volume depletion, hypotension and renal impairment. JANUMET should be temporarily discontinued while patients have restricted food and fluid intake.

Hypoxic States

Several of the postmarketing cases of metformin-associated lactic acidosis occurred in the setting of acute congestive heart failure (particularly when accompanied by hypoperfusion and hypoxemia). Cardiovascular collapse (shock), acute myocardial infarction, sepsis, and other conditions associated with hypoxemia have been associated with lactic acidosis and may also cause prerenal azotemia. When such events occur, discontinue JANUMET.

Excessive Alcohol Intake

Alcohol potentiates the effect of metformin on lactate metabolism and this may increase the risk of metformin-associated lactic acidosis. Warn patients against excessive alcohol intake while receiving JANUMET.

Hepatic Impairment

Patients with hepatic impairment have developed with cases of metformin-associated lactic acidosis. This may be due to impaired lactate clearance resulting in higher lactate blood levels. Therefore, avoid use of JANUMET in patients with clinical or laboratory evidence of hepatic disease.

5.2 Pancreatitis

There have been postmarketing reports of acute pancreatitis, including fatal and non-fatal hemorrhagic or necrotizing pancreatitis, in patients taking JANUMET. After initiation of JANUMET, patients should be observed carefully for signs and symptoms of pancreatitis. If pancreatitis is suspected, JANUMET should promptly be discontinued and appropriate management should be initiated. It is unknown whether patients with a history of pancreatitis are at increased risk for the development of pancreatitis while using JANUMET.

5.3 Heart Failure

An association between dipeptidyl peptidase-4 (DPP-4) inhibitor treatment and heart failure has been observed in cardiovascular outcomes trials for two other members of the DPP-4 inhibitor class. These trials evaluated patients with type 2 diabetes mellitus and atherosclerotic cardiovascular disease.

Consider the risks and benefits of JANUMET prior to initiating treatment in patients at risk for heart failure, such as those with a prior history of heart failure and a history of renal impairment, and observe these patients for signs and symptoms of heart failure during therapy. Advise patients of the characteristic symptoms of heart failure and to immediately report such symptoms. If heart failure develops, evaluate and manage according to current standards of care and consider discontinuation of JANUMET.

5.4 Assessment of Renal Function

Metformin and sitagliptin are known to be substantially excreted by the kidney.

Metformin HCl

JANUMET is contraindicated in patients with severe renal impairment [see *Contraindications (4) and Warnings and Precautions (5.1)*].

Sitagliptin

There have been postmarketing reports of worsening renal function, including acute renal failure, sometimes requiring dialysis. Before initiation of therapy with JANUMET and at least annually thereafter, renal function should be assessed. In patients in whom development of renal dysfunction is anticipated, particularly in elderly patients, renal function should be assessed more frequently and JANUMET discontinued if evidence of renal impairment is present.

5.5 Vitamin B₁₂ Deficiency

In controlled clinical trials of metformin of 29 weeks duration, a decrease to subnormal levels of previously normal serum vitamin B₁₂ levels was observed in approximately 7% of patients. Such decrease, possibly due to interference with B₁₂ absorption from the B₁₂-intrinsic factor complex, may be associated with anemia but appears to be rapidly reversible with discontinuation of metformin or vitamin B₁₂ supplementation. Certain individuals (those with inadequate vitamin B₁₂ or calcium intake or absorption) appear to be predisposed to developing subnormal vitamin B₁₂ levels. Measure hematologic parameters on an annual basis and vitamin B₁₂ measurements at 2- to 3-year intervals in patients on JANUMET and manage any abnormalities [see *Adverse Reactions (6.1)*].

5.6 Change in Clinical Status of Patients with Previously Controlled Type 2 Diabetes

A patient with type 2 diabetes previously well controlled on JANUMET who develops laboratory abnormalities or clinical illness (especially vague and poorly defined illness) should be evaluated promptly for evidence of ketoacidosis or lactic acidosis. Evaluation should include serum electrolytes and ketones, blood glucose and, if indicated, blood pH, lactate, pyruvate, and metformin levels. If acidosis of either form occurs, JANUMET must be stopped immediately and other appropriate corrective measures initiated.

5.7 Use with Medications Known to Cause Hypoglycemia

Sitagliptin

When sitagliptin was used in combination with a sulfonylurea or with insulin, medications known to cause hypoglycemia, the incidence of hypoglycemia was increased over that of placebo used in combination with a sulfonylurea or with insulin [see *Adverse Reactions (6)*]. Therefore, patients also receiving an insulin secretagogue (e.g., sulfonylurea) or insulin may require a lower dose of the insulin secretagogue or insulin to reduce the risk of hypoglycemia [see *Drug Interactions (7.4)*].

Metformin HCl

Hypoglycemia does not occur in patients receiving metformin alone under usual circumstances of use, but could occur when caloric intake is deficient, when strenuous exercise is not compensated by caloric supplementation, or during concomitant use with other glucose-lowering agents (such as sulfonylureas and insulin) or ethanol. Elderly, debilitated, or malnourished patients, and those with adrenal or pituitary insufficiency or alcohol intoxication are particularly susceptible to hypoglycemic effects. Hypoglycemia may be difficult to recognize in the elderly, and in people who are taking β -adrenergic blocking drugs.

5.8 Loss of Control of Blood Glucose

When a patient stabilized on any diabetic regimen is exposed to stress such as fever, trauma, infection, or surgery, a temporary loss of glycemic control may occur. At such times, it may be necessary to withhold JANUMET and temporarily administer insulin. JANUMET may be reinstated after the acute episode is resolved.

5.9 Hypersensitivity Reactions

There have been postmarketing reports of serious hypersensitivity reactions in patients treated with sitagliptin, one of the components of JANUMET. These reactions include anaphylaxis, angioedema, and exfoliative skin conditions including Stevens-Johnson syndrome. Onset of these reactions occurred within the first 3 months after initiation of treatment with sitagliptin, with some reports occurring after the first dose. If a hypersensitivity reaction is suspected, discontinue JANUMET, assess for other potential causes for the event, and institute alternative treatment for diabetes. [See *Adverse Reactions (6.2).*]

Angioedema has also been reported with other DPP-4 inhibitors. Use caution in a patient with a history of angioedema with another DPP-4 inhibitor because it is unknown whether such patients will be predisposed to angioedema with JANUMET.

5.10 Severe and Disabling Arthralgia

There have been postmarketing reports of severe and disabling arthralgia in patients taking DPP-4 inhibitors. The time to onset of symptoms following initiation of drug therapy varied from one day to years. Patients experienced relief of symptoms upon discontinuation of the medication. A subset of patients experienced a recurrence of symptoms when restarting the same drug or a different DPP-4 inhibitor. Consider DPP-4 inhibitors as a possible cause for severe joint pain and discontinue drug if appropriate.

5.11 Bullous Pemphigoid

Postmarketing cases of bullous pemphigoid requiring hospitalization have been reported with DPP-4 inhibitor use. In reported cases, patients typically recovered with topical or systemic immunosuppressive treatment and discontinuation of the DPP-4 inhibitor. Tell patients to report development of blisters or erosions while receiving JANUMET. If bullous pemphigoid is suspected, JANUMET should be discontinued and referral to a dermatologist should be considered for diagnosis and appropriate treatment.

5.12 Macrovascular Outcomes

There have been no clinical studies establishing conclusive evidence of macrovascular risk reduction with JANUMET.

6 ADVERSE REACTIONS

6.1 Clinical Trials Experience

Because clinical trials are conducted under widely varying conditions, adverse reaction rates observed in the clinical trials of a drug cannot be directly compared to rates in the clinical trials of another drug and may not reflect the rates observed in practice.

Sitagliptin and Metformin Coadministration in Patients with Type 2 Diabetes Inadequately Controlled on Diet and Exercise

Table 1 summarizes the most common ($\geq 5\%$ of patients) adverse reactions reported (regardless of investigator assessment of causality) in a 24-week placebo-controlled factorial study in which sitagliptin and metformin were coadministered to patients with type 2 diabetes inadequately controlled on diet and exercise.

Table 1: Sitagliptin and Metformin Coadministered to Patients with Type 2 Diabetes Inadequately Controlled on Diet and Exercise: Adverse Reactions Reported (Regardless of Investigator Assessment of Causality) in ≥5% of Patients Receiving Combination Therapy (and Greater than in Patients Receiving Placebo)*

	Number of Patients (%)			
	Placebo	Sitagliptin 100 mg once daily	Metformin 500 mg/ Metformin 1000 mg twice daily [†]	Sitagliptin 50 mg twice daily + Metformin 500 mg/ Metformin 1000 mg twice daily [†]
	N = 176	N = 179	N = 364 [†]	N = 372 [†]
Diarrhea	7 (4.0)	5 (2.8)	28 (7.7)	28 (7.5)
Upper Respiratory Tract Infection	9 (5.1)	8 (4.5)	19 (5.2)	23 (6.2)
Headache	5 (2.8)	2 (1.1)	14 (3.8)	22 (5.9)

* Intent-to-treat population.

[†] Data pooled for the patients given the lower and higher doses of metformin.

Sitagliptin Add-on Therapy in Patients with Type 2 Diabetes Inadequately Controlled on Metformin Alone

In a 24-week placebo-controlled trial of sitagliptin 100 mg administered once daily added to a twice daily metformin regimen, there were no adverse reactions reported regardless of investigator assessment of causality in ≥5% of patients and more commonly than in patients given placebo. Discontinuation of therapy due to clinical adverse reactions was similar to the placebo treatment group (sitagliptin and metformin, 1.9%; placebo and metformin, 2.5%).

Gastrointestinal Adverse Reactions

The incidences of pre-selected gastrointestinal adverse experiences in patients treated with sitagliptin and metformin were similar to those reported for patients treated with metformin alone. See Table 2.

Table 2: Pre-selected Gastrointestinal Adverse Reactions (Regardless of Investigator Assessment of Causality) Reported in Patients with Type 2 Diabetes Receiving Sitagliptin and Metformin

	Number of Patients (%)					
	Study of Sitagliptin and Metformin in Patients Inadequately Controlled on Diet and Exercise				Study of Sitagliptin Add-on in Patients Inadequately Controlled on Metformin Alone	
	Placebo	Sitagliptin 100 mg once daily	Metformin 500 mg/ Metformin 1000 mg twice daily*	Sitagliptin 50 mg twice daily + Metformin 500 mg/ Metformin 1000 mg twice daily*	Placebo and Metformin ≥1500 mg daily	Sitagliptin 100 mg once daily and Metformin ≥1500 mg daily
	N = 176	N = 179	N = 364	N = 372	N = 237	N = 464
Diarrhea	7 (4.0)	5 (2.8)	28 (7.7)	28 (7.5)	6 (2.5)	11 (2.4)
Nausea	2 (1.1)	2 (1.1)	20 (5.5)	18 (4.8)	2 (0.8)	6 (1.3)
Vomiting	1 (0.6)	0 (0.0)	2 (0.5)	8 (2.2)	2 (0.8)	5 (1.1)
Abdominal Pain [†]	4 (2.3)	6 (3.4)	14 (3.8)	11 (3.0)	9 (3.8)	10 (2.2)

* Data pooled for the patients given the lower and higher doses of metformin.

[†] Abdominal discomfort was included in the analysis of abdominal pain in the study of initial therapy.

Sitagliptin in Combination with Metformin and Glimepiride

In a 24-week placebo-controlled study of sitagliptin 100 mg as add-on therapy in patients with type 2 diabetes inadequately controlled on metformin and glimepiride (sitagliptin, N=116; placebo, N=113), the adverse reactions reported regardless of investigator assessment of causality in ≥5% of patients treated with sitagliptin and more commonly than in patients treated with placebo were: hypoglycemia (Table 3) and headache (6.9%, 2.7%).

Sitagliptin in Combination with Metformin and Rosiglitazone

In a placebo-controlled study of sitagliptin 100 mg as add-on therapy in patients with type 2 diabetes inadequately controlled on metformin and rosiglitazone (sitagliptin, N=181; placebo, N=97), the adverse reactions reported regardless of investigator assessment of causality through Week 18 in $\geq 5\%$ of patients treated with sitagliptin and more commonly than in patients treated with placebo were: upper respiratory tract infection (sitagliptin, 5.5%; placebo, 5.2%) and nasopharyngitis (6.1%, 4.1%). Through Week 54, the adverse reactions reported regardless of investigator assessment of causality in $\geq 5\%$ of patients treated with sitagliptin and more commonly than in patients treated with placebo were: upper respiratory tract infection (sitagliptin, 15.5%; placebo, 6.2%), nasopharyngitis (11.0%, 9.3%), peripheral edema (8.3%, 5.2%), and headache (5.5%, 4.1%).

Sitagliptin in Combination with Metformin and Insulin

In a 24-week placebo-controlled study of sitagliptin 100 mg as add-on therapy in patients with type 2 diabetes inadequately controlled on metformin and insulin (sitagliptin, N=229; placebo, N=233), the only adverse reaction reported regardless of investigator assessment of causality in $\geq 5\%$ of patients treated with sitagliptin and more commonly than in patients treated with placebo was hypoglycemia (Table 3).

Hypoglycemia

In the above studies (N=5), adverse reactions of hypoglycemia were based on all reports of symptomatic hypoglycemia; a concurrent glucose measurement was not required although most (77%) reports of hypoglycemia were accompanied by a blood glucose measurement ≤ 70 mg/dL. When the combination of sitagliptin and metformin was coadministered with a sulfonylurea or with insulin, the percentage of patients reporting at least one adverse reaction of hypoglycemia was higher than that observed with placebo and metformin coadministered with a sulfonylurea or with insulin (Table 3).

Table 3: Incidence and Rate of Hypoglycemia* (Regardless of Investigator Assessment of Causality) in Placebo-Controlled Clinical Studies of Sitagliptin in Combination with Metformin Coadministered with Glimepiride or Insulin

Add-On to Glimepiride + Metformin (24 weeks)	Sitagliptin 100 mg + Metformin + Glimepiride	Placebo + Metformin + Glimepiride
	N = 116	N = 113
Overall (%)	19 (16.4)	1 (0.9)
Rate (episodes/patient-year) [†]	0.82	0.02
Severe (%) [‡]	0 (0.0)	0 (0.0)
Add-On to Insulin + Metformin (24 weeks)	Sitagliptin 100 mg + Metformin + Insulin	Placebo + Metformin + Insulin
	N = 229	N = 233
Overall (%)	35 (15.3)	19 (8.2)
Rate (episodes/patient-year) [†]	0.98	0.61
Severe (%) [‡]	1 (0.4)	1 (0.4)

* Adverse reactions of hypoglycemia were based on all reports of symptomatic hypoglycemia; a concurrent glucose measurement was not required: Intent-to-treat population.

[†] Based on total number of events (i.e., a single patient may have had multiple events).

[‡] Severe events of hypoglycemia were defined as those events requiring medical assistance or exhibiting depressed level/loss of consciousness or seizure.

The overall incidence of reported adverse reactions of hypoglycemia in patients with type 2 diabetes inadequately controlled on diet and exercise was 0.6% in patients given placebo, 0.6% in patients given sitagliptin alone, 0.8% in patients given metformin alone, and 1.6% in patients given sitagliptin in combination with metformin. In patients with type 2 diabetes inadequately controlled on metformin alone, the overall incidence of adverse reactions of hypoglycemia was 1.3% in patients given add-on sitagliptin and 2.1% in patients given add-on placebo.

In the study of sitagliptin and add-on combination therapy with metformin and rosiglitazone, the overall incidence of hypoglycemia was 2.2% in patients given add-on sitagliptin and 0.0% in patients given add-on placebo through Week 18. Through Week 54, the overall incidence of hypoglycemia was 3.9% in patients given add-on sitagliptin and 1.0% in patients given add-on placebo.

In an additional, 30-week placebo-controlled, study of patients with type 2 diabetes inadequately controlled with metformin comparing the maintenance of sitagliptin 100 mg versus withdrawal of sitagliptin when initiating basal insulin therapy, the event rate and incidence of documented symptomatic hypoglycemia (blood glucose measurement ≤ 70 mg/dL) did not differ between the sitagliptin and placebo groups.

Vital Signs and Electrocardiograms

With the combination of sitagliptin and metformin, no clinically meaningful changes in vital signs or in ECG (including in QTc interval) were observed.

Pancreatitis

In a pooled analysis of 19 double-blind clinical trials that included data from 10,246 patients randomized to receive sitagliptin 100 mg/day (N=5429) or corresponding (active or placebo) control (N=4817), the incidence of acute pancreatitis was 0.1 per 100 patient-years in each group (4 patients with an event in 4708 patient-years for sitagliptin and 4 patients with an event in 3942 patient-years for control). [See *Warnings and Precautions (5.2)*.]

Sitagliptin

The most common adverse experience in sitagliptin monotherapy reported regardless of investigator assessment of causality in $\geq 5\%$ of patients and more commonly than in patients given placebo was nasopharyngitis.

Metformin HCl

The most common ($>5\%$) established adverse reactions due to initiation of metformin therapy are diarrhea, nausea/vomiting, flatulence, abdominal discomfort, indigestion, asthenia, and headache.

Laboratory Tests

Sitagliptin

The incidence of laboratory adverse reactions was similar in patients treated with sitagliptin and metformin (7.6%) compared to patients treated with placebo and metformin (8.7%). In most but not all studies, a small increase in white blood cell count (approximately 200 cells/microL difference in WBC vs placebo; mean baseline WBC approximately 6600 cells/microL) was observed due to a small increase in neutrophils. This change in laboratory parameters is not considered to be clinically relevant.

Metformin HCl

In controlled clinical trials of metformin of 29 weeks duration, a decrease to subnormal levels of previously normal serum vitamin B₁₂ levels, without clinical manifestations, was observed in approximately 7% of patients. Such decrease, possibly due to interference with B₁₂ absorption from the B₁₂-intrinsic factor complex, is, however, very rarely associated with anemia and appears to be rapidly reversible with discontinuation of metformin or vitamin B₁₂ supplementation. [See *Warnings and Precautions (5.5)*.]

6.2 Postmarketing Experience

Additional adverse reactions have been identified during postapproval use of JANUMET, sitagliptin, or metformin. Because these reactions are reported voluntarily from a population of uncertain size, it is generally not possible to reliably estimate their frequency or establish a causal relationship to drug exposure.

Hypersensitivity reactions including anaphylaxis, angioedema, rash, urticaria, cutaneous vasculitis, and exfoliative skin conditions including Stevens-Johnson syndrome [see *Warnings and Precautions (5.9)*]; upper respiratory tract infection; hepatic enzyme elevations; acute pancreatitis, including fatal and non-fatal hemorrhagic and necrotizing pancreatitis [see *Indications and Usage (1)*; *Warnings and Precautions (5.2)*]; worsening renal function, including acute renal failure (sometimes requiring dialysis) [see *Warnings and Precautions (5.4)*]; severe and disabling arthralgia [see *Warnings and Precautions (5.10)*]; bullous pemphigoid [see *Warnings and Precautions (5.11)*]; constipation; vomiting; headache; myalgia; pain in extremity; back pain; pruritus; mouth ulceration; stomatitis; cholestatic, hepatocellular, and mixed hepatocellular liver injury; rhabdomyolysis.

7 DRUG INTERACTIONS

7.1 Carbonic Anhydrase Inhibitors

Topiramate or other carbonic anhydrase inhibitors (e.g., zonisamide, acetazolamide or dichlorophenamide) frequently cause a decrease in serum bicarbonate and induce non-anion gap,

hyperchloremic metabolic acidosis. Concomitant use of these drugs with JANUMET may increase the risk of lactic acidosis. Consider more frequent monitoring of these patients.

7.2 Drugs that Reduce Metformin Clearance

Concomitant use of drugs that interfere with common renal tubular transport systems involved in the renal elimination of metformin (e.g., organic cationic transporter-2 [OCT2] / multidrug and toxin extrusion [MATE] inhibitors such as ranolazine, vandetanib, dolutegravir, and cimetidine) could increase systemic exposure to metformin and may increase the risk for lactic acidosis [see *Clinical Pharmacology (12.3)*]. Consider the benefits and risks of concomitant use.

7.3 Alcohol

Alcohol is known to potentiate the effect of metformin on lactate metabolism. Warn patients against excessive alcohol intake while receiving JANUMET.

7.4 Insulin Secretagogues or Insulin

Coadministration of JANUMET with an insulin secretagogue (e.g., sulfonylurea) or insulin may require lower doses of the insulin secretagogue or insulin to reduce the risk of hypoglycemia. [See *Warnings and Precautions (5.7)*.]

7.5 Use of Metformin with Other Drugs

Certain drugs tend to produce hyperglycemia and may lead to loss of glycemic control. These drugs include the thiazides and other diuretics, corticosteroids, phenothiazines, thyroid products, estrogens, oral contraceptives, phenytoin, nicotinic acid, sympathomimetics, calcium channel blocking drugs, and isoniazid. When such drugs are administered to a patient receiving JANUMET the patient should be closely observed to maintain adequate glycemic control.

7.6 Digoxin

There was a slight increase in the area under the curve (AUC, 11%) and mean peak drug concentration (C_{max} , 18%) of digoxin with the coadministration of 100 mg sitagliptin for 10 days. Patients receiving digoxin should be monitored appropriately. No dosage adjustment of digoxin or JANUMET is recommended.

8 USE IN SPECIFIC POPULATIONS

8.1 Pregnancy

Pregnancy Exposure Registry

There is a pregnancy exposure registry that monitors pregnancy outcomes in women exposed to JANUMET during pregnancy. Health care providers are encouraged to report any prenatal exposure to JANUMET by calling the Pregnancy Registry at 1-800-986-8999.

Risk Summary

The limited available data with JANUMET in pregnant women are not sufficient to inform a drug-associated risk for major birth defects and miscarriage. Published studies with metformin use during pregnancy have not reported a clear association with metformin and major birth defect or miscarriage risk [see *Data*]. There are risks to the mother and fetus associated with poorly controlled diabetes in pregnancy [see *Clinical Considerations*]. No adverse developmental effects were observed when sitagliptin was administered to pregnant rats and rabbits during organogenesis at oral doses up to 30-times and 20-times, respectively, the 100 mg clinical dose, based on AUC. No adverse developmental effects were observed when metformin was administered to pregnant Sprague Dawley rats and rabbits during organogenesis at doses up to 2- and 6-times, respectively, a 2000 mg clinical dose, based on body surface area [see *Data*].

The estimated background risk of major birth defects is 6-10% in women with pre-gestational diabetes with a Hemoglobin A1c >7% and has been reported to be as high as 20-25% in women with a Hemoglobin A1c >10%. In the U.S. general population, the estimated background risk of major birth defects and miscarriage in clinically recognized pregnancies is 2-4% and 15-20% respectively.

Clinical Considerations

Disease-Associated Maternal and/or Embryo/Fetal Risk

Poorly controlled diabetes in pregnancy increases the maternal risk for diabetic ketoacidosis, pre-eclampsia, spontaneous abortions, preterm delivery, and delivery complications. Poorly controlled diabetes increases the fetal risk for major birth defects, still birth, and macrosomia related morbidity.

Data

Human Data

Published data from post-marketing studies do not report a clear association with metformin and major birth defects, miscarriage, or adverse maternal or fetal outcomes when metformin is used during pregnancy. However, these studies cannot definitely establish the absence of any risk because of methodological limitations, including small sample size and inconsistent comparator groups.

Animal Data

Sitagliptin and Metformin

No animal reproduction studies were conducted with the coadministration of sitagliptin and metformin.

Sitagliptin

In embryo-fetal development studies, sitagliptin administered to pregnant rats and rabbits during organogenesis (gestation day 6 to 20) did not adversely affect developmental outcomes at oral doses up to 250 mg/kg (30-times the 100 mg clinical dose) and 125 mg/kg (20-times the 100 mg clinical dose), respectively, based on AUC. Higher doses in rats associated with maternal toxicity increased the incidence of rib malformations in offspring at 1000 mg/kg, or approximately 100-times the clinical dose, based on AUC. Placental transfer of sitagliptin was observed in pregnant rats and rabbits.

Sitagliptin administered to female rats from gestation day 6 to lactation day 21 caused no functional or behavioral toxicity in offspring of rats at doses up to 1000 mg/kg.

Metformin HCl

Metformin HCl did not cause adverse developmental effects when administered to pregnant Sprague Dawley rats and rabbits up to 600 mg/kg/day during the period of organogenesis. This represents an exposure of about 2- and 6-times a 2000 mg clinical dose based on body surface area (mg/m²) for rats and rabbits, respectively.

8.2 Lactation

Risk Summary

JANUMET

There is no information regarding the presence of JANUMET in human milk, the effects on the breastfed infant, or the effects on milk production. Limited published studies report that metformin is present in human milk [see *Data*]. There are no reports of adverse effects on breastfed infants exposed to metformin. There is no information on the effects of metformin on milk production. Sitagliptin is present in rat milk and therefore possibly present in human milk [see *Data*]. The developmental and health benefits of breastfeeding should be considered along with the mother's clinical need for JANUMET and any potential adverse effects on the breastfed infant from JANUMET or from the underlying maternal condition.

Data

Sitagliptin

Sitagliptin is secreted in the milk of lactating rats at a milk to plasma ratio of 4:1.

Metformin HCl

Published clinical lactation studies report that metformin is present in human milk, which resulted in infant doses approximately 0.11% to 1% of the maternal weight-adjusted dosage and a milk/plasma ratio ranging between 0.13 and 1. However, the studies were not designed to definitely establish the risk of use of metformin during lactation because of small sample size and limited adverse event data collected in infants.

8.3 Females and Males of Reproductive Potential

Discuss the potential for unintended pregnancy with premenopausal women as therapy with metformin may result in ovulation in some anovulatory women.

8.4 Pediatric Use

Safety and effectiveness of JANUMET in pediatric patients under 18 years have not been established.

8.5 Geriatric Use

JANUMET

Because sitagliptin and metformin are substantially excreted by the kidney, and because aging can be associated with reduced renal function, renal function should be assessed more frequently in elderly patients. [See *Warnings and Precautions (5.1, 5.4); Clinical Pharmacology (12.3).*]

Sitagliptin

Of the total number of subjects (N=3884) in Phase II and III clinical studies of sitagliptin, 725 patients were 65 years and over, while 61 patients were 75 years and over. No overall differences in safety or effectiveness were observed between subjects 65 years and over and younger subjects. While this and other reported clinical experience have not identified differences in responses between the elderly and younger patients, greater sensitivity of some older individuals cannot be ruled out.

Metformin HCl

Controlled clinical studies of metformin did not include sufficient numbers of elderly patients to determine whether they respond differently from younger patients, although other reported clinical experience has not identified differences in responses between the elderly and young patients. In general, dose selection for an elderly patient should be cautious, usually starting at the low end of the dosing range, reflecting the greater frequency of decreased hepatic, renal, or cardiac function, and of concomitant disease or other drug therapy and the higher risk of lactic acidosis. Assess renal function more frequently in elderly patients. [See *Contraindications (4); Warnings and Precautions (5.1); Clinical Pharmacology (12.3).*]

8.6 Renal Impairment

JANUMET

JANUMET is not recommended in patients with an eGFR between 30 and less than 45 mL/min/1.73 m² because these patients require a lower dosage of sitagliptin than what is available in the fixed dose combination JANUMET product. JANUMET is contraindicated in severe renal impairment, patients with an eGFR below 30 mL/min/1.73 m². [See *Dosage and Administration (2.2), Contraindications (4), Warnings and Precautions (5.1) and Clinical Pharmacology (12.3).*]

Sitagliptin

Sitagliptin is excreted by the kidney, and sitagliptin exposure is increased in patients with renal impairment. Lower dosages are recommended in patients with eGFR less than 45 mL/min/1.73 m² (moderate and severe renal impairment, as well as in ESRD patients requiring dialysis).

Metformin HCl

Metformin is substantially excreted by the kidney, and the risk of metformin accumulation and lactic acidosis increases with the degree of renal impairment.

8.7 Hepatic Impairment

Use of metformin in patients with hepatic impairment has been associated with some cases of lactic acidosis. JANUMET is not recommended in patients with hepatic impairment. [See *Warnings and Precautions (5.1).*]

10 OVERDOSAGE

In the event of overdose with JANUMET, contact the Poison Control Center.

In the event of an overdose, it is reasonable to employ supportive measures, e.g., remove unabsorbed material from the gastrointestinal tract, employ clinical monitoring (including obtaining an electrocardiogram), and institute supportive therapy as indicated by the patient's clinical status.

Sitagliptin is modestly dialyzable. In clinical studies, approximately 13.5% of the dose was removed over a 3- to 4-hour hemodialysis session. Prolonged hemodialysis may be considered if clinically appropriate. It is not known if sitagliptin is dialyzable by peritoneal dialysis.

Overdose of metformin HCl has occurred, including ingestion of amounts greater than 50 grams. Hypoglycemia was reported in approximately 10% of cases, but no causal association with metformin HCl has been established. Lactic acidosis has been reported in approximately 32% of metformin overdose cases [see *Warnings and Precautions (5.1)*]. Metformin is dialyzable with a clearance of up to

170 mL/min under good hemodynamic conditions. Therefore, hemodialysis may be useful for removal of accumulated drug from patients in whom metformin overdosage is suspected.

11 DESCRIPTION

JANUMET (sitagliptin and metformin HCl) tablets contain two oral antihyperglycemic drugs: sitagliptin and metformin HCl.

Sitagliptin

Sitagliptin is an orally-active inhibitor of the dipeptidyl peptidase-4 (DPP-4) enzyme. Sitagliptin is present in JANUMET tablets in the form of sitagliptin phosphate monohydrate. Sitagliptin phosphate monohydrate is described chemically as 7-[(3*R*)-3-amino-1-oxo-4-(2,4,5-trifluorophenyl)butyl]-5,6,7,8-tetrahydro-3-(trifluoromethyl)-1,2,4-triazolo[4,3-*a*]pyrazine phosphate (1:1) monohydrate with an empirical formula of $C_{16}H_{15}F_6N_5O \cdot H_3PO_4 \cdot H_2O$ and a molecular weight of 523.32. The structural formula is:

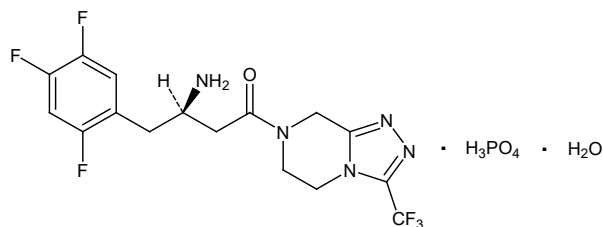

Sitagliptin phosphate monohydrate is a white to off-white, crystalline, non-hygroscopic powder. It is soluble in water and *N,N*-dimethyl formamide; slightly soluble in methanol; very slightly soluble in ethanol, acetone, and acetonitrile; and insoluble in isopropanol and isopropyl acetate.

Metformin HCl

Metformin HCl (*N,N*-dimethylimidodicarbonimidic diamide hydrochloride) is not chemically or pharmacologically related to any other classes of oral antihyperglycemic agents. Metformin HCl is a white to off-white crystalline compound with a molecular formula of $C_4H_{11}N_5 \cdot HCl$ and a molecular weight of 165.63. Metformin HCl is freely soluble in water and is practically insoluble in acetone, ether, and chloroform. The pK_a of metformin is 12.4. The pH of a 1% aqueous solution of metformin HCl is 6.68. The structural formula is as shown:

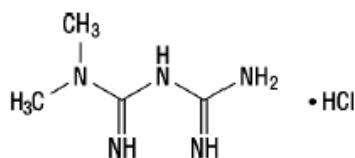

JANUMET

JANUMET is available as film-coated tablets containing:

- 64.25 mg sitagliptin monohydrate equivalent to 50 mg of sitagliptin and 389.93 mg of metformin equivalent to 500 mg metformin HCl (JANUMET 50/500).
- 64.25 mg sitagliptin monohydrate equivalent to 50 mg of sitagliptin and 779.86 mg of metformin equivalent to 1000 mg metformin HCl (JANUMET 50/1000).

Each film-coated tablet of JANUMET contains the following inactive ingredients: microcrystalline cellulose, polyvinylpyrrolidone, sodium lauryl sulfate, and sodium stearyl fumarate. In addition, the film coating contains the following inactive ingredients: polyvinyl alcohol, polyethylene glycol, talc, titanium dioxide, red iron oxide, and black iron oxide.

12 CLINICAL PHARMACOLOGY

12.1 Mechanism of Action

JANUMET

JANUMET combines two antihyperglycemic agents with complementary mechanisms of action to improve glycemic control in patients with type 2 diabetes mellitus: sitagliptin, a dipeptidyl peptidase-4 (DPP-4) inhibitor, and metformin HCl, a member of the biguanide class.

Sitagliptin

Sitagliptin is a DPP-4 inhibitor, which is believed to exert its actions in patients with type 2 diabetes by slowing the inactivation of incretin hormones. Concentrations of the active intact hormones are increased by sitagliptin, thereby increasing and prolonging the action of these hormones. Incretin hormones, including glucagon-like peptide-1 (GLP-1) and glucose-dependent insulintropic polypeptide (GIP), are released by the intestine throughout the day, and levels are increased in response to a meal. These hormones are rapidly inactivated by the enzyme DPP-4. The incretins are part of an endogenous system involved in the physiologic regulation of glucose homeostasis. When blood glucose concentrations are normal or elevated, GLP-1 and GIP increase insulin synthesis and release from pancreatic beta cells by intracellular signaling pathways involving cyclic AMP. GLP-1 also lowers glucagon secretion from pancreatic alpha cells, leading to reduced hepatic glucose production. By increasing and prolonging active incretin levels, sitagliptin increases insulin release and decreases glucagon levels in the circulation in a glucose-dependent manner. Sitagliptin demonstrates selectivity for DPP-4 and does not inhibit DPP-8 or DPP-9 activity *in vitro* at concentrations approximating those from therapeutic doses.

Metformin HCl

Metformin is an antihyperglycemic agent which improves glucose tolerance in patients with type 2 diabetes mellitus, lowering both basal and postprandial plasma glucose. Metformin decreases hepatic glucose production, decreases intestinal absorption of glucose, and improves insulin sensitivity by increasing peripheral glucose uptake and utilization. With metformin therapy, insulin secretion remains unchanged while fasting insulin levels and day-long plasma insulin response may decrease.

12.2 Pharmacodynamics

Sitagliptin

In patients with type 2 diabetes mellitus, administration of sitagliptin led to inhibition of DPP-4 enzyme activity for a 24-hour period. After an oral glucose load or a meal, this DPP-4 inhibition resulted in a 2- to 3-fold increase in circulating levels of active GLP-1 and GIP, decreased glucagon concentrations, and increased responsiveness of insulin release to glucose, resulting in higher C-peptide and insulin concentrations. The rise in insulin with the decrease in glucagon was associated with lower fasting glucose concentrations and reduced glucose excursion following an oral glucose load or a meal.

In studies with healthy subjects, sitagliptin did not lower blood glucose or cause hypoglycemia.

Sitagliptin and Metformin HCl Coadministration

In a two-day study in healthy subjects, sitagliptin alone increased active GLP-1 concentrations, whereas metformin alone increased active and total GLP-1 concentrations to similar extents. Coadministration of sitagliptin and metformin had an additive effect on active GLP-1 concentrations. Sitagliptin, but not metformin, increased active GIP concentrations. It is unclear what these findings mean for changes in glycemic control in patients with type 2 diabetes mellitus.

Cardiac Electrophysiology

In a randomized, placebo-controlled crossover study, 79 healthy subjects were administered a single oral dose of sitagliptin 100 mg, sitagliptin 800 mg (8 times the recommended dose), and placebo. At the recommended dose of 100 mg, there was no effect on the QTc interval obtained at the peak plasma concentration, or at any other time during the study. Following the 800-mg dose, the maximum increase in the placebo-corrected mean change in QTc from baseline at 3 hours postdose was 8.0 msec.

This increase is not considered to be clinically significant. At the 800-mg dose, peak sitagliptin plasma concentrations were approximately 11 times higher than the peak concentrations following a 100-mg dose.

In patients with type 2 diabetes mellitus administered sitagliptin 100 mg (N=81) or sitagliptin 200 mg (N=63) daily, there were no meaningful changes in QTc interval based on ECG data obtained at the time of expected peak plasma concentration.

12.3 Pharmacokinetics

Sitagliptin

The pharmacokinetics of sitagliptin have been extensively characterized in healthy subjects and patients with type 2 diabetes mellitus. Following a single oral 100-mg dose to healthy volunteers, mean plasma AUC of sitagliptin was 8.52 $\mu\text{M}\cdot\text{hr}$, C_{max} was 950 nM, and apparent terminal half-life ($t_{1/2}$) was 12.4 hours. Plasma AUC of sitagliptin increased in a dose-proportional manner and increased approximately 14% following 100 mg doses at steady-state compared to the first dose. The intra-subject and inter-subject coefficients of variation for sitagliptin AUC were small (5.8% and 15.1%). The pharmacokinetics of sitagliptin was generally similar in healthy subjects and in patients with type 2 diabetes mellitus.

Absorption

Sitagliptin

After oral administration of a 100 mg dose to healthy subjects, sitagliptin was rapidly absorbed with peak plasma concentrations (median T_{max}) occurring 1 to 4 hours postdose. The absolute bioavailability of sitagliptin is approximately 87%.

Effect of Food

Coadministration of a high-fat meal with sitagliptin had no effect on the pharmacokinetics of sitagliptin.

Metformin HCl

The absolute bioavailability of a metformin HCl 500-mg tablet given under fasting conditions is approximately 50-60%. Studies using single oral doses of metformin HCl tablets 500 mg to 1,500 mg, and 850 mg to 2,550 mg (approximately 1.3 times the maximum recommended daily dosage), indicate that there is a lack of dose proportionality with increasing doses, which is due to decreased absorption rather than an alteration in elimination.

Effect of Food

Food decreases the extent of and slightly delays the absorption of metformin, as shown by approximately a 40% lower mean peak plasma concentration (C_{max}), a 25% lower area under the plasma concentration versus time curve (AUC), and a 35-minute prolongation of time to peak plasma concentration (T_{max}) following administration of a single 850-mg tablet of metformin with food, compared to the same tablet strength administered fasting. The clinical relevance of these decreases is unknown.

Distribution

Sitagliptin

The mean volume of distribution at steady state following a single 100-mg intravenous dose of sitagliptin to healthy subjects is approximately 198 liters. The fraction of sitagliptin reversibly bound to plasma proteins is low (38%).

Metformin HCl

The apparent volume of distribution (V/F) of metformin following single oral doses of metformin HCl tablets 850 mg averaged 654 ± 358 L. Metformin is negligibly bound to plasma proteins, in contrast to sulfonylureas, which are more than 90% protein bound. Metformin partitions into erythrocytes, most likely as a function of time. At usual clinical doses and dosing schedules of metformin HCl tablets, steady-state plasma concentrations of metformin are reached within 24-48 hours and are generally <1 mcg/mL.

Elimination

Sitagliptin

Approximately 79% of sitagliptin is excreted unchanged in the urine with metabolism being a minor pathway of elimination. The apparent terminal $t_{1/2}$ following a 100 mg oral dose of sitagliptin was approximately 12.4 hours and renal clearance was approximately 350 mL/min.

Metformin HCl

Following oral administration, approximately 90% of the absorbed drug is eliminated via the renal route within the first 24 hours, with a plasma elimination half-life of approximately 6.2 hours. In blood, the elimination half-life is approximately 17.6 hours, suggesting that the erythrocyte mass may be a compartment of distribution.

Metabolism

Sitagliptin

Following a [^{14}C]sitagliptin oral dose, approximately 16% of the radioactivity was excreted as metabolites of sitagliptin. Six metabolites were detected at trace levels and are not expected to contribute to the plasma DPP-4 inhibitory activity of sitagliptin. *In vitro* studies indicated that the primary enzyme responsible for the limited metabolism of sitagliptin was CYP3A4, with contribution from CYP2C8.

Metformin HCl

Intravenous single-dose studies in normal subjects demonstrate that metformin is excreted unchanged in the urine and does not undergo hepatic metabolism (no metabolites have been identified in humans) nor biliary excretion.

Excretion

Sitagliptin

Following administration of an oral [^{14}C]sitagliptin dose to healthy subjects, approximately 100% of the administered radioactivity was eliminated in feces (13%) or urine (87%) within one week of dosing.

Elimination of sitagliptin occurs primarily via renal excretion and involves active tubular secretion. Sitagliptin is a substrate for human organic anion transporter-3 (hOAT-3), which may be involved in the renal elimination of sitagliptin. The clinical relevance of hOAT-3 in sitagliptin transport has not been established. Sitagliptin is also a substrate of p-glycoprotein (P-gp), which may also be involved in mediating the renal elimination of sitagliptin. However, cyclosporine, a P-gp inhibitor, did not reduce the renal clearance of sitagliptin.

Metformin HCl

Elimination of metformin occurs primarily via renal excretion. Renal clearance is approximately 3.5 times greater than creatinine clearance, which indicates that tubular secretion is the major route of metformin elimination.

Specific Populations

Patients with Renal Impairment

JANUMET

Studies characterizing the pharmacokinetics of sitagliptin and metformin after administration of JANUMET in renally impaired patients have not been performed [see *Dosage and Administration (2.2)*].

Sitagliptin

An approximately 2-fold increase in the plasma AUC of sitagliptin was observed in patients with moderate renal impairment with eGFR of 30 to less than 45 mL/min/1.73 m², and an approximately 4-fold increase was observed in patients with severe renal impairment including patients with end-stage renal disease (ESRD) on hemodialysis, as compared to normal healthy control subjects. [See *Dosage and Administration (2.2)*.]

Metformin HCl

In patients with decreased renal function, the plasma and blood half-life of metformin is prolonged and the renal clearance is decreased [see *Contraindications (4); Warnings and Precautions (5.1)*].

Patients with Hepatic Impairment

JANUMET

Studies characterizing the pharmacokinetics of sitagliptin and metformin after administration of JANUMET in patients with hepatic impairment have not been performed.

Sitagliptin

In patients with moderate hepatic impairment (Child-Pugh score 7 to 9), mean AUC and C_{max} of sitagliptin increased approximately 21% and 13%, respectively, compared to healthy matched controls following administration of a single 100-mg dose of sitagliptin. These differences are not considered to be clinically meaningful. There is no clinical experience in patients with severe hepatic impairment (Child-Pugh score >9) [see *Use in Specific Populations (8.7)*].

Metformin HCl

No pharmacokinetic studies of metformin have been conducted in patients with hepatic impairment.

Effects of Age, Body Mass Index (BMI), Gender, and Race

Sitagliptin

Based on a population pharmacokinetic analysis or a composite analysis of available pharmacokinetic data, BMI, gender, and race do not have a clinically meaningful effect on the pharmacokinetics of sitagliptin. When the effects of age on renal function are taken into account, age alone did not have a clinically meaningful impact on the pharmacokinetics of sitagliptin based on a population pharmacokinetic analysis. Elderly subjects (65 to 80 years) had approximately 19% higher plasma concentrations of sitagliptin compared to younger subjects.

Metformin HCl

Limited data from controlled pharmacokinetic studies of metformin in healthy elderly subjects suggest that total plasma clearance of metformin is decreased, the half-life is prolonged, and C_{max} is increased, compared to healthy young subjects. From these data, it appears that the change in metformin pharmacokinetics with aging is primarily accounted for by a change in renal function.

Metformin pharmacokinetic parameters did not differ significantly between normal subjects and patients with type 2 diabetes mellitus when analyzed according to gender. Similarly, in controlled clinical studies in patients with type 2 diabetes mellitus, the antihyperglycemic effect of metformin was comparable in males and females.

No studies of metformin pharmacokinetic parameters according to race have been performed. In controlled clinical studies of metformin in patients with type 2 diabetes mellitus, the antihyperglycemic effect was comparable in Whites (n=249), Blacks (n=51), and Hispanics (n=24).

Pediatric Patients

Sitagliptin

Studies characterizing the pharmacokinetics of sitagliptin in pediatric patients have not been performed.

Drug Interaction Studies

JANUMET

Coadministration of multiple doses of sitagliptin (50 mg) and metformin (1000 mg) given twice daily did not meaningfully alter the pharmacokinetics of either sitagliptin or metformin in patients with type 2 diabetes.

Pharmacokinetic drug interaction studies with JANUMET have not been performed; however, such studies have been conducted with the individual components of JANUMET (sitagliptin and metformin HCl).

Sitagliptin

In Vitro Assessment of Drug Interactions

Sitagliptin is not an inhibitor of CYP isozymes CYP3A4, 2C8, 2C9, 2D6, 1A2, 2C19 or 2B6, and is not an inducer of CYP3A4. Sitagliptin is a P-gp substrate but does not inhibit P-gp mediated transport of digoxin. Based on these results, sitagliptin is considered unlikely to cause interactions with other drugs that utilize these pathways.

Sitagliptin is not extensively bound to plasma proteins. Therefore, the propensity of sitagliptin to be involved in clinically meaningful drug-drug interactions mediated by plasma protein binding displacement is very low.

In Vivo Assessment of Drug Interactions

Effects of Sitagliptin on Other Drugs

In clinical studies, sitagliptin did not meaningfully alter the pharmacokinetics of metformin, glyburide, simvastatin, rosiglitazone, digoxin, warfarin, or an oral contraception (ethinyl estradiol and norethindrone) (Table 4), providing *in vivo* evidence of a low propensity for causing drug interactions with substrates of CYP3A4, CYP2C8, CYP2C9, P-gp, and organic cationic transporter (OCT).

Table 4: Effect of Sitagliptin on Systemic Exposure of Coadministered Drugs

Coadministered Drug	Dose of Coadministered Drug*	Dose of Sitagliptin*	Geometric Mean Ratio (ratio with/without sitagliptin) No Effect = 1.00		
				AUC [†]	C _{max}
Digoxin	0.25 mg [‡] once daily for 10 days	100 mg [‡] once daily for 10 days	Digoxin	1.11 [§]	1.18
Glyburide	1.25 mg	200 mg [‡] once daily for 6 days	Glyburide	1.09	1.01
Simvastatin	20 mg	200 mg [‡] once daily for 5 days	Simvastatin	0.85 [¶]	0.80
			Simvastatin Acid	1.12 [¶]	1.06
Rosiglitazone	4 mg	200 mg [‡] once daily for 5 days	Rosiglitazone	0.98	0.99
Warfarin	30 mg single dose on day 5	200 mg [‡] once daily for 11 days	S(-) Warfarin	0.95	0.89
			R(+) Warfarin	0.99	0.89
Ethinyl estradiol and norethindrone	21 days once daily of 35 µg ethinyl estradiol with norethindrone 0.5 mg x 7 days, 0.75 mg x 7 days, 1.0 mg x 7 days	200 mg [‡] once daily for 21 days	Ethinyl estradiol	0.99	0.97
			Norethindrone	1.03	0.98
Metformin	1000 mg [‡] twice daily for 14 days	50 mg [‡] twice daily for 7 days	Metformin	1.02 [#]	0.97

* All doses administered as single dose unless otherwise specified.

† AUC is reported as AUC_{0-∞} unless otherwise specified.

‡ Multiple dose.

§ AUC_{0-24hr}.

¶ AUC_{0-last}.

AUC_{0-12hr}.

Effects of Other Drugs on Sitagliptin

Clinical data described below suggest that sitagliptin is not susceptible to clinically meaningful interactions by coadministered medications (Table 5).

Table 5: Effect of Coadministered Drugs on Systemic Exposure of Sitagliptin

Coadministered Drug	Dose of Coadministered	Dose of Sitagliptin*	Geometric Mean Ratio (ratio with/without coadministered drug)
---------------------	------------------------	----------------------	---

	Drug*		No Effect = 1.00		
				AUC [†]	C _{max}
Cyclosporine	600 mg once daily	100 mg once daily	Sitagliptin	1.29	1.68
Metformin	1000 mg [‡] twice daily for 14 days	50 mg [‡] twice daily for 7 days	Sitagliptin	1.02 [§]	1.05

* All doses administered as single dose unless otherwise specified.

† AUC is reported as AUC_{0-∞} unless otherwise specified.

‡ Multiple dose.

§ AUC_{0-12hr}.

Metformin HCl

Table 6: Effect of Metformin on Systemic Exposure of Coadministered Drugs

Coadministered Drug	Dose of Coadministered Drug*	Dose of Metformin*	Geometric Mean Ratio (ratio with/without metformin) No Effect = 1.00		
				AUC [†]	C _{max}
Cimetidine	400 mg	850 mg	Cimetidine	0.95 [‡]	1.01
Glyburide	5 mg	500 mg [§]	Glyburide	0.78 [¶]	0.63 [¶]
Furosemide	40 mg	850 mg	Furosemide	0.87 [¶]	0.69 [¶]
Nifedipine	10 mg	850 mg	Nifedipine	1.10 [‡]	1.08
Propranolol	40 mg	850 mg	Propranolol	1.01 [‡]	0.94
Ibuprofen	400 mg	850 mg	Ibuprofen	0.97 [#]	1.01 [#]

* All doses administered as single dose unless otherwise specified.

† AUC is reported as AUC_{0-∞} unless otherwise specified.

‡ AUC_{0-24hr}.

§ GLUMETZA (metformin HCl extended-release tablets) 500 mg.

¶ Ratio of arithmetic means, p value of difference <0.05.

Ratio of arithmetic means.

Table 7: Effect of Coadministered Drugs on Systemic Exposure of Metformin

Coadministered Drug	Dose of Coadministered Drug*	Dose of Metformin*	Geometric Mean Ratio (ratio with/without coadministered drug) No Effect = 1.00		
				AUC [†]	C _{max}
Glyburide	5 mg	500 mg [‡]	Metformin [‡]	0.98 [§]	0.99 [§]
Furosemide	40 mg	850 mg	Metformin	1.09 [§]	1.22 [§]
Nifedipine	10 mg	850 mg	Metformin	1.16	1.21
Propranolol	40 mg	850 mg	Metformin	0.90	0.94
Ibuprofen	400 mg	850 mg	Metformin	1.05 [§]	1.07 [§]
Drugs that are eliminated by renal tubular secretion may increase the accumulation of metformin. [See Warnings and Precautions (5.1) and Drug Interactions (7.2).]					
Cimetidine	400 mg	850 mg	Metformin	1.40	1.61
Carbonic anhydrase inhibitors may cause metabolic acidosis. [See Warnings and Precautions (5.1) and Drug Interactions (7.1).]					
Topiramate	100 mg [¶]	500 mg [¶]	Metformin	1.25 [¶]	1.17

* All doses administered as single dose unless otherwise specified.

† AUC is reported as AUC_{0-∞} unless otherwise specified.

‡ GLUMETZA (metformin HCl extended-release tablets) 500 mg.

§ Ratio of arithmetic means.

¶ Steady state 100 mg Topiramate every 12 hr + metformin 500 mg every 12 hr AUC = AUC_{0-12hr}.

13 NONCLINICAL TOXICOLOGY

13.1 Carcinogenesis, Mutagenesis, Impairment of Fertility

JANUMET

No animal studies have been conducted with the combined products in JANUMET to evaluate carcinogenesis, mutagenesis or impairment of fertility. The following data are based on the findings in studies with sitagliptin and metformin individually.

Sitagliptin

A two-year carcinogenicity study was conducted in male and female rats given oral doses of sitagliptin of 50, 150, and 500 mg/kg/day. There was an increased incidence of combined liver adenoma/carcinoma in males and females and of liver carcinoma in females at 500 mg/kg. This dose results in exposures approximately 60 times the human exposure at the maximum recommended daily adult human dose (MRHD) of 100 mg/day based on AUC comparisons. Liver tumors were not observed at 150 mg/kg, approximately 20 times the human exposure at the MRHD. A two-year carcinogenicity study was conducted in male and female mice given oral doses of sitagliptin of 50, 125, 250, and 500 mg/kg/day. There was no increase in the incidence of tumors in any organ up to 500 mg/kg,

approximately 70 times human exposure at the MRHD. Sitagliptin was not mutagenic or clastogenic with or without metabolic activation in the Ames bacterial mutagenicity assay, a Chinese hamster ovary (CHO) chromosome aberration assay, an *in vitro* cytogenetics assay in CHO, an *in vitro* rat hepatocyte DNA alkaline elution assay, and an *in vivo* micronucleus assay.

In rat fertility studies with oral gavage doses of 125, 250, and 1000 mg/kg, males were treated for 4 weeks prior to mating, during mating, up to scheduled termination (approximately 8 weeks total), and females were treated 2 weeks prior to mating through gestation day 7. No adverse effect on fertility was observed at 125 mg/kg (approximately 12 times human exposure at the MRHD of 100 mg/day based on AUC comparisons). At higher doses, nondose-related increased resorptions in females were observed (approximately 25 and 100 times human exposure at the MRHD based on AUC comparison).

Metformin HCl

Long-term carcinogenicity studies have been performed in rats (dosing duration of 104 weeks) and mice (dosing duration of 91 weeks) at doses up to and including 900 mg/kg/day and 1500 mg/kg/day, respectively. These doses are both approximately four times the maximum recommended human daily dose of 2000 mg based on body surface area comparisons. No evidence of carcinogenicity with metformin was found in either male or female mice. Similarly, there was no tumorigenic potential observed with metformin in male rats. There was, however, an increased incidence of benign stromal uterine polyps in female rats treated with 900 mg/kg/day.

There was no evidence of a mutagenic potential of metformin in the following *in vitro* tests: Ames test (*S. typhimurium*), gene mutation test (mouse lymphoma cells), or chromosomal aberrations test (human lymphocytes). Results in the *in vivo* mouse micronucleus test were also negative. Fertility of male or female rats was unaffected by metformin when administered at doses as high as 600 mg/kg/day, which is approximately three times the maximum recommended human daily dose based on body surface area comparisons.

14 CLINICAL STUDIES

The coadministration of sitagliptin and metformin has been studied in patients with type 2 diabetes inadequately controlled on diet and exercise and in combination with other antihyperglycemic agents.

None of the clinical efficacy studies described below was conducted with JANUMET; however, bioequivalence of JANUMET with coadministered sitagliptin and metformin HCl tablets was demonstrated.

Sitagliptin and Metformin Coadministration in Patients with Type 2 Diabetes Inadequately Controlled on Diet and Exercise

A total of 1091 patients with type 2 diabetes and inadequate glycemic control on diet and exercise participated in a 24-week, randomized, double-blind, placebo-controlled factorial study designed to assess the efficacy of sitagliptin and metformin coadministration. Patients on an antihyperglycemic agent (N=541) underwent a diet, exercise, and drug washout period of up to 12 weeks duration. After the washout period, patients with inadequate glycemic control (A1C 7.5% to 11%) were randomized after completing a 2-week single-blind placebo run-in period. Patients not on antihyperglycemic agents at study entry (N=550) with inadequate glycemic control (A1C 7.5% to 11%) immediately entered the 2-week single-blind placebo run-in period and then were randomized. Approximately equal numbers of patients were randomized to receive placebo, 100 mg of sitagliptin once daily, 500 mg or 1000 mg of metformin twice daily, or 50 mg of sitagliptin twice daily in combination with 500 mg or 1000 mg of metformin twice daily. Patients who failed to meet specific glycemic goals during the study were treated with glyburide (glibenclamide) rescue.

Sitagliptin and metformin coadministration provided significant improvements in A1C, FPG, and 2-hour PPG compared to placebo, to metformin alone, and to sitagliptin alone (Table 8, Figure 1). Mean reductions from baseline in A1C were generally greater for patients with higher baseline A1C values. For patients not on an antihyperglycemic agent at study entry, mean reductions from baseline in A1C were: sitagliptin 100 mg once daily, -1.1%; metformin 500 mg bid, -1.1%; metformin 1000 mg bid, -1.2%; sitagliptin 50 mg bid with metformin 500 mg bid, -1.6%; sitagliptin 50 mg bid with metformin 1000 mg bid, -1.9%; and for patients receiving placebo, -0.2%. Lipid effects were generally neutral. The decrease in body weight in the groups given sitagliptin in combination with metformin was similar to that in the groups given metformin alone or placebo.

Table 8: Glycemic Parameters at Final Visit (24-Week Study) for Sitagliptin and Metformin, Alone and in Combination in Patients with Type 2 Diabetes Inadequately Controlled on Diet and Exercise*

	Placebo	Sitagliptin 100 mg once daily	Metformin 500 mg twice daily	Metformin 1000 mg twice daily	Sitagliptin 50 mg twice daily + Metformin 500 mg twice daily	Sitagliptin 50 mg twice daily + Metformin 1000 mg twice daily
A1C (%)	N = 165	N = 175	N = 178	N = 177	N = 183	N = 178
Baseline (mean)	8.7	8.9	8.9	8.7	8.8	8.8
Change from baseline (adjusted mean [†])	0.2	-0.7	-0.8	-1.1	-1.4	-1.9
Difference from placebo (adjusted mean [†]) (95% CI)		-0.8 [‡] (-1.1, -0.6)	-1.0 [‡] (-1.2, -0.8)	-1.3 [‡] (-1.5, -1.1)	-1.6 [‡] (-1.8, -1.3)	-2.1 [‡] (-2.3, -1.8)
Patients (%) achieving A1C <7%	15 (9%)	35 (20%)	41 (23%)	68 (38%)	79 (43%)	118 (66%)
% Patients receiving rescue medication	32	21	17	12	8	2
FPG (mg/dL)	N = 169	N = 178	N = 179	N = 179	N = 183	N = 180
Baseline (mean)	196	201	205	197	204	197
Change from baseline (adjusted mean [†])	6	-17	-27	-29	-47	-64
Difference from placebo (adjusted mean [†]) (95% CI)		-23 [‡] (-33, -14)	-33 [‡] (-43, -24)	-35 [‡] (-45, -26)	-53 [‡] (-62, -43)	-70 [‡] (-79, -60)
2-hour PPG (mg/dL)	N = 129	N = 136	N = 141	N = 138	N = 147	N = 152
Baseline (mean)	277	285	293	283	292	287
Change from baseline (adjusted mean [†])	0	-52	-53	-78	-93	-117
Difference from placebo (adjusted mean [†]) (95% CI)		-52 [‡] (-67, -37)	-54 [‡] (-69, -39)	-78 [‡] (-93, -63)	-93 [‡] (-107, -78)	-117 [‡] (-131, -102)

* Intent-to-treat population using last observation on study prior to glyburide (glibenclamide) rescue therapy.

[†] Least squares means adjusted for prior antihyperglycemic therapy status and baseline value.

[‡] p<0.001 compared to placebo.

Figure 1: Mean Change from Baseline for A1C (%) over 24 Weeks with Sitagliptin and Metformin, Alone and in Combination in Patients with Type 2 Diabetes Inadequately Controlled with Diet and Exercise*

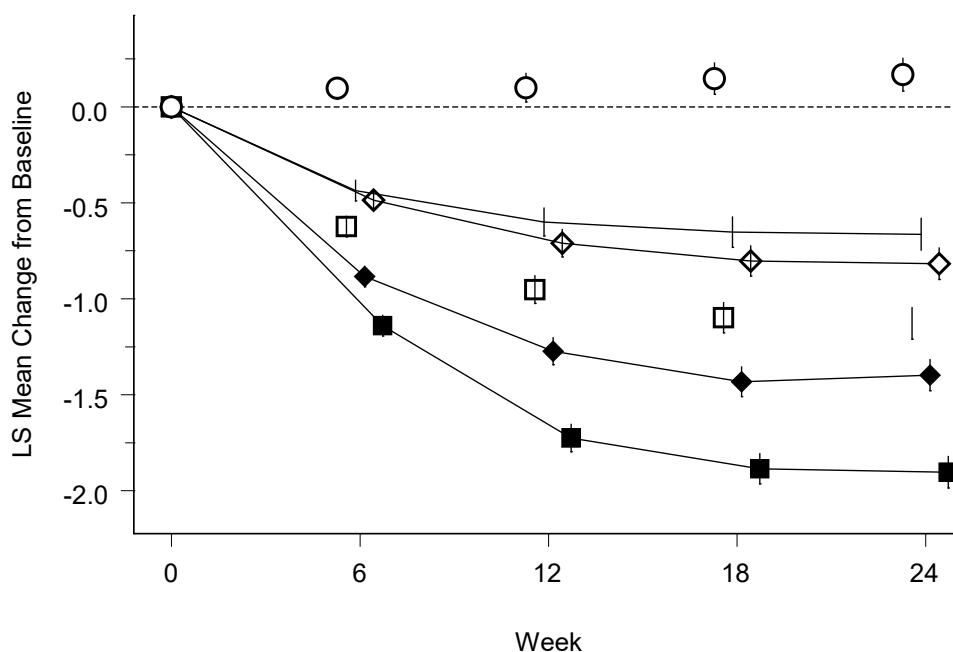

- Placebo
- Sitagliptin 100 mg q.d.
- ◇ Metformin 500 mg b.i.d.
- Metformin 1000 mg b.i.d.
- ◆ Sitagliptin 50 mg b.i.d. + Metformin 500 mg b.i.d.
- Sitagliptin 50 mg b.i.d. + Metformin 1000 mg b.i.d.

* All Patients Treated Population: least squares means adjusted for prior antihyperglycemic therapy and baseline value.

Initial combination therapy or maintenance of combination therapy should be individualized and are left to the discretion of the health care provider.

Sitagliptin Add-on Therapy in Patients with Type 2 Diabetes Inadequately Controlled on Metformin Alone

A total of 701 patients with type 2 diabetes participated in a 24-week, randomized, double-blind, placebo-controlled study designed to assess the efficacy of sitagliptin in combination with metformin. Patients already on metformin (N=431) at a dose of at least 1500 mg per day were randomized after completing a 2-week, single-blind placebo run-in period. Patients on metformin and another antihyperglycemic agent (N=229) and patients not on any antihyperglycemic agents (off therapy for at least 8 weeks, N=41) were randomized after a run-in period of approximately 10 weeks on metformin (at a dose of at least 1500 mg per day) in monotherapy. Patients were randomized to the addition of either 100 mg of sitagliptin or placebo, administered once daily. Patients who failed to meet specific glycemic goals during the studies were treated with pioglitazone rescue.

In combination with metformin, sitagliptin provided significant improvements in A1C, FPG, and 2-hour PPG compared to placebo with metformin (Table 9). Rescue glycemic therapy was used in 5% of patients treated with sitagliptin 100 mg and 14% of patients treated with placebo. A similar decrease in body weight was observed for both treatment groups.

Table 9: Glycemic Parameters at Final Visit (24-Week Study) of Sitagliptin as Add-on Combination Therapy with Metformin*

	Sitagliptin 100 mg once daily + Metformin	Placebo + Metformin
A1C (%)	N = 453	N = 224
Baseline (mean)	8.0	8.0
Change from baseline (adjusted mean [†])	-0.7	-0.0
Difference from placebo + metformin (adjusted mean [†]) (95% CI)	-0.7 [‡] (-0.8, -0.5)	
Patients (%) achieving A1C <7%	213 (47%)	41 (18%)
FPG (mg/dL)	N = 454	N = 226
Baseline (mean)	170	174
Change from baseline (adjusted mean [†])	-17	9
Difference from placebo + metformin (adjusted mean [†]) (95% CI)	-25 [‡] (-31, -20)	
2-hour PPG (mg/dL)	N = 387	N = 182
Baseline (mean)	275	272
Change from baseline (adjusted mean [†])	-62	-11
Difference from placebo + metformin (adjusted mean [†]) (95% CI)	-51 [‡] (-61, -41)	

* Intent-to-treat population using last observation on study prior to pioglitazone rescue therapy.

[†] Least squares means adjusted for prior antihyperglycemic therapy and baseline value.

[‡] p<0.001 compared to placebo + metformin.

Sitagliptin Add-on Therapy in Patients with Type 2 Diabetes Inadequately Controlled on the Combination of Metformin and Glimepiride

A total of 441 patients with type 2 diabetes participated in a 24-week, randomized, double-blind, placebo-controlled study designed to assess the efficacy of sitagliptin in combination with glimepiride, with or without metformin. Patients entered a run-in treatment period on glimepiride (≥ 4 mg per day) alone or glimepiride in combination with metformin (≥ 1500 mg per day). After a dose-titration and dose-stable run-in period of up to 16 weeks and a 2-week placebo run-in period, patients with inadequate glycemic control (A1C 7.5% to 10.5%) were randomized to the addition of either 100 mg of sitagliptin or placebo, administered once daily. Patients who failed to meet specific glycemic goals during the studies were treated with pioglitazone rescue.

Patients receiving sitagliptin with metformin and glimepiride had significant improvements in A1C and FPG compared to patients receiving placebo with metformin and glimepiride (Table 10), with mean reductions from baseline relative to placebo in A1C of -0.9% and in FPG of -21 mg/dL. Rescue therapy was used in 8% of patients treated with add-on sitagliptin 100 mg and 29% of patients treated with add-on placebo. The patients treated with add-on sitagliptin had a mean increase in body weight of 1.1 kg vs. add-on placebo (+0.4 kg vs. -0.7 kg). In addition, add-on sitagliptin resulted in an increased rate of hypoglycemia compared to add-on placebo. [See *Warnings and Precautions (5.7)*; *Adverse Reactions (6.1)*.]

Table 10: Glycemic Parameters at Final Visit (24-Week Study) for Sitagliptin in Combination with Metformin and Glimepiride*

	Sitagliptin 100 mg + Metformin and Glimepiride	Placebo + Metformin and Glimepiride
A1C (%)	N = 115	N = 105
Baseline (mean)	8.3	8.3
Change from baseline (adjusted mean [†])	-0.6	0.3
Difference from placebo (adjusted mean [†]) (95% CI)	-0.9 [‡] (-1.1, -0.7)	
Patients (%) achieving A1C <7%	26 (23%)	1 (1%)
FPG (mg/dL)	N = 115	N = 109
Baseline (mean)	179	179
Change from baseline (adjusted mean [†])	-8	13
Difference from placebo (adjusted mean [†]) (95% CI)	-21 [‡] (-32, -10)	

* Intent-to-treat population using last observation on study prior to pioglitazone rescue therapy.

[†] Least squares means adjusted for prior antihyperglycemic therapy status and baseline value.

[‡] p<0.001 compared to placebo.

Sitagliptin Add-on Therapy in Patients with Type 2 Diabetes Inadequately Controlled on the Combination of Metformin and Rosiglitazone

A total of 278 patients with type 2 diabetes participated in a 54-week, randomized, double-blind, placebo-controlled study designed to assess the efficacy of sitagliptin in combination with metformin and rosiglitazone. Patients on dual therapy with metformin ≥ 1500 mg/day and rosiglitazone ≥ 4 mg/day or with metformin ≥ 1500 mg/day and pioglitazone ≥ 30 mg/day (switched to rosiglitazone ≥ 4 mg/day) entered a dose-stable run-in period of 6 weeks. Patients on other dual therapy were switched to metformin ≥ 1500 mg/day and rosiglitazone ≥ 4 mg/day in a dose titration/stabilization run-in period of up to 20 weeks in duration. After the run-in period, patients with inadequate glycemic control (A1C 7.5% to 11%) were randomized 2:1 to the addition of either 100 mg of sitagliptin or placebo, administered once daily. Patients who failed to meet specific glycemic goals during the studies were treated with glipizide (or other sulfonylurea) rescue. The primary time point for evaluation of glycemic parameters was Week 18.

In combination with metformin and rosiglitazone, sitagliptin provided significant improvements in A1C, FPG, and 2-hour PPG compared to placebo with metformin and rosiglitazone (Table 11) at Week 18. At Week 54, mean reduction in A1C was -1.0% for patients treated with sitagliptin and -0.3% for patients treated with placebo in an analysis based on the intent-to-treat population. Rescue therapy was used in 18% of patients treated with sitagliptin 100 mg and 40% of patients treated with placebo. There was no significant difference between sitagliptin and placebo in body weight change.

Table 11: Glycemic Parameters at Week 18 for Sitagliptin in Add-on Combination Therapy with Metformin and Rosiglitazone*

	Week 18	
	Sitagliptin 100 mg + Metformin + Rosiglitazone	Placebo + Metformin + Rosiglitazone
A1C (%)	N = 176	N = 93
Baseline (mean)	8.8	8.7
Change from baseline (adjusted mean [†])	-1.0	-0.4
Difference from placebo + rosiglitazone + metformin (adjusted mean [†]) (95% CI)	-0.7 [‡] (-0.9,-0.4)	
Patients (%) achieving A1C <7%	39 (22%)	9 (10%)
FPG (mg/dL)	N = 179	N = 94
Baseline (mean)	181	182
Change from baseline (adjusted mean [†])	-30	-11
Difference from placebo + rosiglitazone + metformin (adjusted mean [†]) (95% CI)	-18 [‡] (-26, -10)	
2-hour PPG (mg/dL)	N = 152	N = 80
Baseline (mean)	256	248
Change from baseline (adjusted mean [†])	-59	-21
Difference from placebo + rosiglitazone + metformin (adjusted mean [†]) (95% CI)	-39 [‡] (-51, -26)	

* Intent-to-treat population using last observation on study prior to glipizide (or other sulfonylurea) rescue therapy.

[†] Least squares means adjusted for prior antihyperglycemic therapy status and baseline value.

[‡] p<0.001 compared to placebo + metformin + rosiglitazone.

Sitagliptin Add-on Therapy in Patients with Type 2 Diabetes Inadequately Controlled on the Combination of Metformin and Insulin

A total of 641 patients with type 2 diabetes participated in a 24-week, randomized, double-blind, placebo-controlled study designed to assess the efficacy of sitagliptin as add-on to insulin therapy. Approximately 75% of patients were also taking metformin. Patients entered a 2-week, single-blind run-in treatment period on pre-mixed, long-acting, or intermediate-acting insulin, with or without metformin (≥ 1500 mg per day). Patients using short-acting insulins were excluded unless the short-acting insulin was administered as part of a pre-mixed insulin. After the run-in period, patients with inadequate glycemic control (A1C 7.5% to 11%) were randomized to the addition of either 100 mg of sitagliptin (N=229) or placebo (N=233), administered once daily. Patients were on a stable dose of insulin prior to enrollment with no changes in insulin dose permitted during the run-in period. Patients who failed to meet specific glycemic goals during the double-blind treatment period were to have uptitration of the background insulin dose as rescue therapy.

Among patients also receiving metformin, the median daily insulin (pre-mixed, intermediate or long acting) dose at baseline was 40 units in the sitagliptin-treated patients and 42 units in the placebo-treated patients. The median change from baseline in daily dose of insulin was zero for both groups at the end of the study. Patients receiving sitagliptin with metformin and insulin had significant improvements in A1C, FPG and 2-hour PPG compared to patients receiving placebo with metformin and insulin (Table 12). The adjusted mean change from baseline in body weight was -0.3 kg in patients receiving sitagliptin with metformin and insulin and -0.2 kg in patients receiving placebo with metformin and insulin. There was an increased rate of hypoglycemia in patients treated with sitagliptin. [See *Warnings and Precautions (5.7); Adverse Reactions (6.1).*]

Table 12: Glycemic Parameters at Final Visit (24-Week Study) for Sitagliptin as Add-on Combination Therapy with Metformin and Insulin*

	Sitagliptin 100 mg + Metformin + Insulin	Placebo + Metformin + Insulin
A1C (%)	N = 223	N = 229
Baseline (mean)	8.7	8.6
Change from baseline (adjusted mean ^{†,‡})	-0.7	-0.1
Difference from placebo (adjusted mean [†]) (95% CI)	-0.5 [§] (-0.7, -0.4)	
Patients (%) achieving A1C <7%	32 (14%)	12 (5%)
FPG (mg/dL)	N = 225	N = 229
Baseline (mean)	173	176
Change from baseline (adjusted mean [†])	-22	-4
Difference from placebo (adjusted mean [†]) (95% CI)	-18 [§] (-28, -8.4)	
2-hour PPG (mg/dL)	N = 182	N = 189
Baseline (mean)	281	281
Change from baseline (adjusted mean [†])	-39	1
Difference from placebo (adjusted mean [†]) (95% CI)	-40 [§] (-53, -28)	

* Intent-to-treat population using last observation on study prior to rescue therapy.

[†] Least squares means adjusted for insulin use at the screening visit, type of insulin used at the screening visit (pre-mixed vs. non pre-mixed [intermediate- or long-acting]), and baseline value.

[‡] Treatment by insulin stratum interaction was not significant (p >0.10).

[§] p<0.001 compared to placebo.

Maintenance of Sitagliptin During Initiation and Titration of Insulin Glargine

A total of 746 patients with type 2 diabetes (mean baseline HbA1C 8.8%, disease duration 10.8 years) participated in a 30-week, randomized, double-blind, placebo-controlled study to assess the efficacy and safety of continuing sitagliptin during the initiation and uptitration of insulin glargine. Patients who were on a stable dose of metformin (≥ 1500 mg/day) in combination with a DPP-4 inhibitor and/or sulfonylurea but with inadequate glycemic control (A1C 7.5% to 11%) were enrolled in the study. Those on metformin and sitagliptin (100 mg/day) directly entered the double-blind treatment period; those on another DPP-4 inhibitor and/or on a sulfonylurea entered a 4-8 week run-in period in which they were maintained on metformin and switched to sitagliptin (100 mg); other DPP-4 inhibitors and sulfonylureas were discontinued. At randomization patients were randomized either to continue sitagliptin or to discontinue sitagliptin and switch to a matching placebo. On the day of randomization, insulin glargine was initiated at a dose of 10 units subcutaneously in the evening. Patients were instructed to uptitrate their insulin dose in the evening based on fasting blood glucose measurements to achieve a target of 72-100 mg/dL.

At 30 weeks, the mean reduction in A1C was greater in the sitagliptin group than in the placebo group (Table 13). At the end of the trial, 27.3% of patients in the sitagliptin group and 27.3% in the placebo group had a fasting plasma glucose (FPG) in the target range; there was no significant difference in insulin dose between arms.

Table 13: Change from Baseline in A1C and FPG at Week 30 in the Maintenance of Sitagliptin During Initiation and Titration of Insulin Glargine Study

	Sitagliptin 100 mg +Metformin + Insulin Glargine	Placebo +Metformin + Insulin Glargine
A1C (%)	N = 373[†]	N = 370[†]
Baseline (mean)	8.8	8.8
Week 30 (mean)	6.9	7.3
Change from baseline (adjusted mean)*	-1.9	-1.4
Difference from placebo (adjusted mean) (95% CI)*	-0.4 (-0.6, -0.3) [‡]	
Patients (%) with A1C <7%	202 (54.2%)	131 (35.4%)
FPG (mg/dL)	N = 373[†]	N = 370[†]
Baseline (mean)	199	201
Week 30 (mean)	118	123
Change from baseline (adjusted mean)*	-81	-76

* Analysis of Covariance including all post-baseline data regardless of rescue or treatment discontinuation. Model estimates calculated using multiple imputation to model washout of the treatment effect using placebo data for all subjects having missing Week 30 data.

[†] N is the number of randomized and treated patients.

[‡] p<0.001 compared to placebo.

Sitagliptin Add-on Therapy vs. Glipizide Add-on Therapy in Patients with Type 2 Diabetes Inadequately Controlled on Metformin

The efficacy of sitagliptin was evaluated in a 52-week, double-blind, glipizide-controlled noninferiority trial in patients with type 2 diabetes. Patients not on treatment or on other antihyperglycemic agents entered a run-in treatment period of up to 12 weeks duration with metformin monotherapy (dose of ≥1500 mg per day) which included washout of medications other than metformin, if applicable. After the run-in period, those with inadequate glycemic control (A1C 6.5% to 10%) were randomized 1:1 to the addition of sitagliptin 100 mg once daily or glipizide for 52 weeks. Patients receiving glipizide were given an initial dosage of 5 mg/day and then electively titrated over the next 18 weeks to a maximum dosage of 20 mg/day as needed to optimize glycemic control. Thereafter, the glipizide dose was to be kept constant, except for down-titration to prevent hypoglycemia. The mean dose of glipizide after the titration period was 10 mg.

After 52 weeks, sitagliptin and glipizide had similar mean reductions from baseline in A1C in the intent-to-treat analysis (Table 14). These results were consistent with the per protocol analysis (Figure 2). A conclusion in favor of the non-inferiority of sitagliptin to glipizide may be limited to patients with baseline A1C comparable to those included in the study (over 70% of patients had baseline A1C less than 8% and over 90% had A1C less than 9%).

Table 14: Glycemic Parameters in a 52-Week Study Comparing Sitagliptin to Glipizide as Add-On Therapy in Patients Inadequately Controlled on Metformin (Intent-to-Treat Population)*

	Sitagliptin 100 mg + Metformin	Glipizide + Metformin
A1C (%)	N = 576	N = 559
Baseline (mean)	7.7	7.6
Change from baseline (adjusted mean [†])	-0.5	-0.6
FPG (mg/dL)	N = 583	N = 568
Baseline (mean)	166	164
Change from baseline (adjusted mean [†])	-8	-8

* The intent-to-treat analysis used the patients' last observation in the study prior to discontinuation.

[†] Least squares means adjusted for prior antihyperglycemic therapy status and baseline A1C value.

Figure 2: Mean Change from Baseline for A1C (%) Over 52 Weeks in a Study Comparing Sitagliptin to Glipizide as Add-On Therapy in Patients Inadequately Controlled on Metformin (Per Protocol Population) *

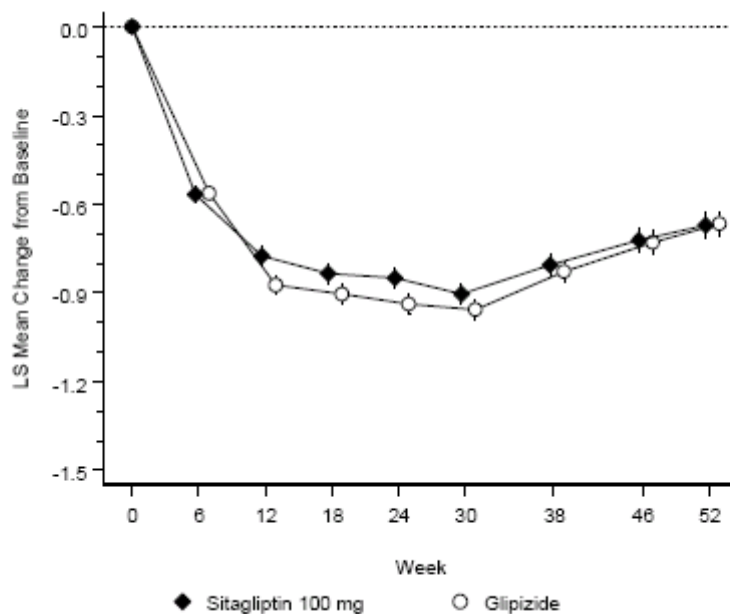

* The per protocol population (mean baseline A1C of 7.5%) included patients without major protocol violations who had observations at baseline and at Week 52.

The incidence of hypoglycemia in the sitagliptin group (4.9%) was significantly ($p < 0.001$) lower than that in the glipizide group (32.0%). Patients treated with sitagliptin exhibited a significant mean decrease from baseline in body weight compared to a significant weight gain in patients administered glipizide (-1.5 kg vs. +1.1 kg).

16 HOW SUPPLIED/STORAGE AND HANDLING

Tablets: JANUMET, 50 mg/500 mg, are light pink, capsule-shaped, film-coated tablets with “575” debossed on one side. They are supplied as follows:

- NDC 0006-0575-61 unit-of-use bottles of 60
- NDC 0006-0575-62 unit-of-use bottles of 180
- NDC 0006-0575-82 bulk bottles of 1000.

Tablets: JANUMET, 50 mg/1000 mg, are red, capsule-shaped, film-coated tablets with “577” debossed on one side. They are supplied as follows:

- NDC 0006-0577-61 unit-of-use bottles of 60
- NDC 0006-0577-62 unit-of-use bottles of 180
- NDC 0006-0577-82 bulk bottles of 1000.

Store at 20-25°C (68-77°F), excursions permitted to 15-30°C (59-86°F). [See USP Controlled Room Temperature.]

17 PATIENT COUNSELING INFORMATION

Advise the patient to read the FDA-approved patient labeling (Medication Guide).

Lactic Acidosis

Inform patients of the risks of lactic acidosis due to the metformin component, its symptoms, and conditions that predispose to its development, as noted in Warnings and Precautions (5.1). Advise

patients to discontinue JANUMET immediately and to promptly notify their health practitioner if unexplained hyperventilation, myalgia, malaise, unusual somnolence, dizziness, slow or irregular heart beat, sensation of feeling cold (especially in the extremities) or other nonspecific symptoms occur. Gastrointestinal symptoms are common during initiation of metformin treatment and may occur during initiation of JANUMET therapy; however, inform patients to consult their physician if they develop unexplained symptoms. Although gastrointestinal symptoms that occur after stabilization are unlikely to be drug related, such an occurrence of symptoms should be evaluated to determine if it may be due to lactic acidosis or other serious disease. Instruct patients to inform their doctor that they are taking JANUMET prior to any surgical or radiological procedure, as temporary discontinuation of JANUMET may be required until renal function has been confirmed to have returned to its prior level [see *Warnings and Precautions* (5.1)].

Counsel patients against excessive alcohol intake, either acute or chronic, while receiving JANUMET.

Inform patients about the importance of regular testing of renal function and hematological parameters when receiving treatment with JANUMET.

Pancreatitis

Inform patients that acute pancreatitis has been reported during postmarketing use of JANUMET. Inform patients that persistent severe abdominal pain, sometimes radiating to the back, which may or may not be accompanied by vomiting, is the hallmark symptom of acute pancreatitis. Instruct patients to promptly discontinue JANUMET and contact their physician if persistent severe abdominal pain occurs [see *Warnings and Precautions* (5.2)].

Heart Failure

Inform patients of the signs and symptoms of heart failure. Before initiating JANUMET, ask patients about a history of heart failure or other risk factors for heart failure including moderate to severe renal impairment. Instruct patients to contact their health care provider as soon as possible if they experience symptoms of heart failure, including increasing shortness of breath, rapid increase in weight or swelling of the feet [see *Warnings and Precautions* (5.3)].

Hypoglycemia

Inform patients that the incidence of hypoglycemia is increased when JANUMET is added to an insulin secretagogue (e.g., sulfonylurea) or insulin therapy and that a lower dose of the insulin secretagogue or insulin may be required to reduce the risk of hypoglycemia.

Hypersensitivity Reactions

Inform patients that allergic reactions have been reported during postmarketing use of sitagliptin, one of the components of JANUMET. If symptoms of allergic reactions (including rash, hives, and swelling of the face, lips, tongue, and throat that may cause difficulty in breathing or swallowing) occur, patients must stop taking JANUMET and seek medical advice promptly.

Severe and Disabling Arthralgia

Inform patients that severe and disabling joint pain may occur with this class of drugs. The time to onset of symptoms can range from one day to years. Instruct patients to seek medical advice if severe joint pain occurs [see *Warnings and Precautions* (5.10)].

Bullous Pemphigoid

Inform patients that bullous pemphigoid may occur with this class of drugs. Instruct patients to seek medical advice if blisters or erosions occur [see *Warnings and Precautions* (5.11)].

Administration Instructions

Inform patients that the tablets must never be split or divided before swallowing.

For patent information: www.merck.com/product/patent/home.html

The trademarks depicted herein are owned by their respective companies.

Copyright © 2007-2019 Merck Sharp & Dohme Corp., a subsidiary of **Merck & Co., Inc.**
All rights reserved.

uspi-mk0431a-t-1908r019

Medication Guide
JANUMET® (JAN-you-met)
(sitagliptin and metformin hydrochloride)
Tablets

Read this Medication Guide carefully before you start taking JANUMET and each time you get a refill. There may be new information. This information does not take the place of talking with your doctor about your medical condition or your treatment. If you have any questions about JANUMET, ask your doctor or pharmacist.

What is the most important information I should know about JANUMET?

Serious side effects can happen in people taking JANUMET, including:

1. Lactic Acidosis. Metformin, one of the medicines in JANUMET, can cause a rare but serious condition called lactic acidosis (a buildup of an acid in the blood) that can cause death. Lactic acidosis is a medical emergency and must be treated in the hospital.

Call your doctor right away if you have any of the following symptoms, which could be signs of lactic acidosis:

- you feel cold in your hands or feet
- you feel dizzy or lightheaded
- you have a slow or irregular heartbeat
- you feel very weak or tired
- you have unusual (not normal) muscle pain
- you have trouble breathing
- you feel sleepy or drowsy
- you have stomach pains, nausea or vomiting

Most people who have had lactic acidosis with metformin have other things that, combined with the metformin, led to the lactic acidosis. Tell your doctor if you have any of the following, because you have a higher chance for getting lactic acidosis with JANUMET if you:

- have severe kidney problems or your kidneys are affected by certain x-ray tests that use injectable dye
- have liver problems
- drink alcohol very often, or drink a lot of alcohol in short-term "binge" drinking
- get dehydrated (lose a large amount of body fluids). This can happen if you are sick with a fever, vomiting, or diarrhea. Dehydration can also happen when you sweat a lot with activity or exercise and do not drink enough fluids
- have surgery
- have a heart attack, severe infection, or stroke

The best way to keep from having a problem with lactic acidosis from metformin is to tell your doctor if you have any of the problems in the list above. Your doctor may decide to stop your JANUMET for a while if you have any of these things.

JANUMET can have other serious side effects. See **"What are the possible side effects of JANUMET?"**

2. Pancreatitis (inflammation of the pancreas) which may be severe and lead to death.

Certain medical problems make you more likely to get pancreatitis.

Before you start taking JANUMET:

Tell your doctor if you have ever had

- pancreatitis
- stones in your gallbladder (gallstones)
- a history of alcoholism
- high blood triglyceride levels

Stop taking JANUMET and call your doctor right away if you have pain in your stomach area (abdomen) that is severe and will not go away. The pain may be felt going from your abdomen through to your back. The pain may happen with or without vomiting. These may be symptoms of pancreatitis.

3. Heart failure. Heart failure means that your heart does not pump blood well enough.

Before you start taking JANUMET, tell your doctor if you have ever had heart failure or have problems with your kidneys.

Contact your doctor right away if you have any of the following symptoms:

- increasing shortness of breath or trouble breathing, especially when you lie down
- swelling or fluid retention, especially in the feet, ankles or legs
- an unusually fast increase in weight
- unusual tiredness

These may be symptoms of heart failure.

What is JANUMET?

- JANUMET is a prescription medicine that contains 2 prescription diabetes medicines, sitagliptin (JANUVIA®) and metformin. JANUMET can be used along with diet and exercise to lower blood sugar in adults with type 2 diabetes.

- JANUMET is not for people with type 1 diabetes.
- JANUMET is not for people with diabetic ketoacidosis (increased ketones in your blood or urine).
- If you have had pancreatitis (inflammation of the pancreas) in the past, it is not known if you have a higher chance of getting pancreatitis while you take JANUMET.
- It is not known if JANUMET is safe and effective when used in children under 18 years of age.

Who should not take JANUMET?

Do not take JANUMET if:

- you have severe kidney problems.
- you are allergic to any of the ingredients in JANUMET. See the end of this Medication Guide for a complete list of ingredients in JANUMET.

Symptoms of a serious allergic reaction to JANUMET may include rash, raised red patches on your skin (hives) or swelling of the face, lips, tongue, and throat that may cause difficulty in breathing or swallowing.

- you have diabetic ketoacidosis. See "**What is JANUMET?**".

What should I tell my doctor before taking JANUMET?

Before you take JANUMET, tell your doctor if you:

- have or have had inflammation of your pancreas (pancreatitis).
- have severe kidney problems.
- have liver problems.
- have heart problems, including congestive heart failure.
- drink alcohol very often, or drink a lot of alcohol in short-term "binge" drinking.
- are going to get an injection of dye or contrast agents for an x-ray procedure; JANUMET may need to be stopped for a short time. Talk to your doctor about when you should stop JANUMET and when you should start JANUMET again. See "**What is the most important information I should know about JANUMET?**".

- have any other medical conditions.

- are pregnant or plan to become pregnant. It is not known if JANUMET will harm your unborn baby. If you are pregnant, talk with your doctor about the best way to control your blood sugar while you are pregnant.

Pregnancy Registry: If you take JANUMET at any time during your pregnancy, talk with your doctor about how you can join the JANUMET pregnancy registry. The purpose of this registry is to collect information about the health of you and your baby. You can enroll in this registry by calling 1-800-986-8999.

- are breast-feeding or plan to breast-feed. It is not known if JANUMET will pass into your breast milk. Talk with your doctor about the best way to feed your baby if you are taking JANUMET.

Tell your doctor about all the medicines you take, including prescription and over-the-counter medicines, vitamins, and herbal supplements. JANUMET may affect how well other drugs work and some drugs can affect how well JANUMET works.

Know the medicines you take. Keep a list of your medicines and show it to your doctor and pharmacist when you get a new medicine.

How should I take JANUMET?

- Take JANUMET exactly as your doctor tells you. Your doctor will tell you how many JANUMET tablets to take and when you should take them.
- Your doctor may change your dose of JANUMET if needed.
- Your doctor may tell you to take JANUMET along with certain other diabetes medicines. Low blood sugar (hypoglycemia) can happen more often when JANUMET is taken with certain other diabetes medicines. See "**What are the possible side effects of JANUMET?**".
- Take JANUMET with meals to help to lower your chance of having an upset stomach.
- Do not break or cut JANUMET tablets before swallowing. If you cannot swallow JANUMET tablets whole, tell your doctor.
- Continue to take JANUMET as long as your doctor tells you.
- If you take too much JANUMET, call your doctor or local Poison Control Center right away.
- If you miss a dose, take it as soon as you remember. If you do not remember until it is time for your next dose, skip the missed dose and go back to your regular schedule. Do not take 2 doses of JANUMET at the same time.
- You may need to stop taking JANUMET for a short time. Call your doctor for instructions if you:
 - are dehydrated (have lost too much body fluid). Dehydration can occur if you are sick with severe vomiting, diarrhea or fever, or if you drink a lot less fluid than normal.
 - plan to have surgery.
 - are going to get an injection of dye or contrast agent for an x-ray procedure. See "**What is the most important information I should know about JANUMET?**" and "**What should I tell my doctor before taking JANUMET?**".
- When your body is under some types of stress, such as fever, trauma (such as a car accident), infection or surgery, the amount of diabetes medicine that you need may change. Tell your doctor right away if you have any of these problems and follow your doctor's instructions.

- Check your blood sugar as your doctor tells you to.
- Stay on your prescribed diet and exercise program while taking JANUMET.
- Talk to your doctor about how to prevent, recognize and manage low blood sugar (hypoglycemia), high blood sugar (hyperglycemia), and problems you have because of your diabetes.
- Your doctor will check your diabetes with regular blood tests, including your blood sugar levels and your hemoglobin A1C.
- Your doctor will do blood tests to check how well your kidneys are working before and during your treatment with JANUMET.

What are the possible side effects of JANUMET?

Serious side effects have happened in people taking JANUMET or the individual medicines in JANUMET.

- See "**What is the most important information I should know about JANUMET?**".
- **Low blood sugar (hypoglycemia).** If you take JANUMET with another medicine that can cause low blood sugar, such as a sulfonylurea or insulin, your risk of getting low blood sugar is higher. The dose of your sulfonylurea medicine or insulin may need to be lowered while you use JANUMET. Signs and symptoms of low blood sugar may include:
 - headache
 - drowsiness
 - irritability
 - hunger
 - dizziness
 - confusion
 - sweating
 - feeling jittery
 - weakness
 - fast heart beat
- **Serious allergic reactions.** If you have any symptoms of a serious allergic reaction, stop taking JANUMET and call your doctor right away. See "**Who should not take JANUMET?**". Your doctor may give you a medicine for your allergic reaction and prescribe a different medicine for your diabetes.
- **Kidney problems,** sometimes requiring dialysis.
- **Joint pain.** Some people who take medicines called DPP-4 inhibitors, one of the medicines in JANUMET, may develop joint pain that can be severe. Call your doctor if you have severe joint pain.
- **Skin reaction.** Some people who take medicines called DPP-4 inhibitors, one of the medicines in JANUMET, may develop a skin reaction called bullous pemphigoid that can require treatment in a hospital. Tell your doctor right away if you develop blisters or the breakdown of the outer layer of your skin (erosion). Your doctor may tell you to stop taking JANUMET.

The most common side effects of JANUMET include:

- stuffy or runny nose and sore throat
- gas, upset stomach, indigestion
- headache
- upper respiratory infection
- weakness
- diarrhea
- low blood sugar (hypoglycemia) when used in combination with certain medications, such as a sulfonylurea or insulin.
- nausea and vomiting

Taking JANUMET with meals can help lessen the common stomach side effects of metformin that usually happen at the beginning of treatment. If you have unusual or sudden stomach problems, talk with your doctor. Stomach problems that start later during treatment may be a sign of something more serious.

JANUMET may have other side effects, including swelling of the hands or legs. Swelling of the hands and legs can happen if you take JANUMET in combination with rosiglitazone (Avandia®). Rosiglitazone is another type of diabetes medicine.

These are not all the possible side effects of JANUMET. For more information, ask your doctor or pharmacist.

Tell your doctor if you have any side effect that bothers you, is unusual, or does not go away.

Call your doctor for medical advice about side effects. You may report side effects to FDA at 1-800-FDA-1088.

How should I store JANUMET?

Store JANUMET at 68°F to 77°F (20°C to 25°C).

Keep JANUMET and all medicines out of the reach of children.

General information about the use of JANUMET.

Medicines are sometimes prescribed for purposes other than those listed in Medication Guides. Do not use JANUMET for a condition for which it was not prescribed. Do not give JANUMET to other people, even if they have the same symptoms you have. It may harm them.

This Medication Guide summarizes the most important information about JANUMET. If you would like to know more information, talk with your doctor. You can ask your doctor or pharmacist for additional information about JANUMET that is written for health care professionals. For more information go to www.janumet.com or call 1-800-622-4477.

What are the ingredients in JANUMET?

Active ingredients: sitagliptin and metformin

Inactive ingredients: microcrystalline cellulose, polyvinylpyrrolidone, sodium lauryl sulfate, and sodium stearyl fumarate. The tablet film coating contains the following inactive ingredients: polyvinyl alcohol, polyethylene glycol, talc, titanium dioxide, red iron oxide, and black iron oxide.

What is type 2 diabetes?

Type 2 diabetes is a condition in which your body does not make enough insulin, and the insulin that your body produces does not work as well as it should. Your body can also make too much sugar. When this happens, sugar (glucose) builds up in the blood. This can lead to serious medical problems.

High blood sugar can be lowered by diet and exercise, and by certain medicines when necessary.

Dist. by: Merck Sharp & Dohme Corp., a subsidiary of

 **MERCK & CO., INC.**, Whitehouse Station, NJ 08889, USA

For patent information: www.merck.com/product/patent/home.html. The trademarks depicted herein are owned by their respective companies. Copyright © 2010-20XX Merck Sharp & Dohme Corp., a subsidiary of **Merck & Co., Inc.** All rights reserved. usmg-mk0431a-t-XXXXrXXX

This Medication Guide has been approved by the U.S. Food and Drug Administration.

Revised: XX/20XX

PRODUCT MONOGRAPH

 **JANUVIA**[®]

sitagliptin tablets
25, 50 and 100 mg
sitagliptin (as sitagliptin phosphate monohydrate), tablets, oral

ATC Code: A10BH01

Dipeptidyl peptidase 4 (DPP-4) inhibitors

Merck Canada Inc.
16750 route Transcanadienne
Kirkland, QC Canada H9H 4M7
www.merck.ca

Date of Revision:
November 1, 2018

Submission Control No: 211741

Table of Contents

PART I: HEALTH PROFESSIONAL INFORMATION	3
SUMMARY PRODUCT INFORMATION.....	3
INDICATIONS AND CLINICAL USE	3
CONTRAINDICATIONS.....	4
WARNINGS AND PRECAUTIONS	4
ADVERSE REACTIONS	7
DRUG INTERACTIONS	22
DOSAGE AND ADMINISTRATION	24
OVERDOSAGE.....	26
ACTION AND CLINICAL PHARMACOLOGY	26
STORAGE AND STABILITY	30
DOSAGE FORMS, COMPOSITION AND PACKAGING.....	30
PART II: SCIENTIFIC INFORMATION	31
PHARMACEUTICAL INFORMATION.....	31
CLINICAL TRIALS	32
DETAILED PHARMACOLOGY	45
TOXICOLOGY.....	46
REFERENCES.....	48
PART III: CONSUMER INFORMATION	49

JANUVIA[®]

sitagliptin tablets
(as sitagliptin phosphate monohydrate)

PART I: HEALTH PROFESSIONAL INFORMATION

SUMMARY PRODUCT INFORMATION

Route of Administration	Dosage Form / Strength	Clinically Relevant Non-medicinal Ingredients
Oral	Tablet 25, 50 and 100 mg	<i>For a complete listing see DOSAGE FORMS, COMPOSITION AND PACKAGING section.</i>

INDICATIONS AND CLINICAL USE

Monotherapy

JANUVIA[®] (sitagliptin) is indicated as an adjunct to diet and exercise to improve glycemic control in adult patients with type 2 diabetes mellitus and for whom metformin is inappropriate due to contraindications or intolerance.

Combination with Metformin

JANUVIA[®] is indicated in combination with metformin in adult patients with type 2 diabetes mellitus to improve glycemic control when diet and exercise, plus metformin do not provide adequate glycemic control.

Combination with Metformin and a Sulfonylurea

JANUVIA[®] is indicated in combination with metformin and a sulfonylurea in adult patients with type 2 diabetes mellitus to improve glycemic control when diet and exercise, and dual therapy with these agents, do not provide adequate glycemic control.

Combination with Insulin

JANUVIA[®] is indicated as add-on combination therapy with premixed or long/intermediate acting insulin (with or without metformin) in adult patients with type 2 diabetes mellitus as an adjunct to diet and exercise to improve glycemic control when diet and exercise, and therapy with premixed or long/intermediate acting insulin (with or without metformin) do not provide adequate glycemic control.

Combination with Pioglitazone

JANUVIA[®] is indicated in combination with pioglitazone in adult patients with type 2 diabetes mellitus to improve glycemic control when diet and exercise, plus pioglitazone do not provide adequate glycemic control.

Combination with Metformin and Pioglitazone

JANUVIA[®] is indicated in combination with metformin and pioglitazone in adult patients with type 2 diabetes mellitus to improve glycemic control when diet and exercise, and dual therapy with these agents, do not provide adequate glycemic control.

See [CLINICAL TRIALS](#) section.

Geriatrics (≥65 years of age): No dosage adjustment is required based on age however, greater sensitivity of some older individuals cannot be ruled out (see [WARNINGS AND PRECAUTIONS](#), [DOSAGE AND ADMINISTRATION](#) and [ACTION AND CLINICAL PHARMACOLOGY](#)).

Pediatrics (<18 years of age): Safety and effectiveness of JANUVIA[®] in pediatric patients have not been established. Therefore, JANUVIA[®] should not be used in this population.

CONTRAINDICATIONS

JANUVIA[®] is contraindicated in:

- Patients with a history of a hypersensitive reaction to JANUVIA[®] or to any ingredient in the formulation, including any non-medicinal ingredient or component of the container (see [WARNINGS AND PRECAUTIONS](#) and [ADVERSE REACTIONS](#)). For a complete listing, see the [DOSAGE FORMS, COMPOSITION AND PACKAGING](#) section.

WARNINGS AND PRECAUTIONS

General

JANUVIA[®] should not be used in patients with type 1 diabetes or for the treatment of diabetic ketoacidosis.

Endocrine and Metabolism

Hypoglycemia: When JANUVIA[®] was used in combination with metformin and a sulfonylurea, or with a stable dose of insulin (with or without metformin), the incidence of hypoglycemia was increased over that of placebo used in combination with metformin and a sulfonylurea or in combination with insulin (with or without metformin) (see [ADVERSE REACTIONS](#)). To reduce the risk of hypoglycemia associated with these indications, a lower dose of sulfonylurea or insulin may be considered (see [DOSAGE AND ADMINISTRATION](#)).

Loss of Control of Blood Glucose: The effectiveness of oral antidiabetic drugs in lowering blood glucose to a targeted level decreases in many patients over a period of time. This phenomenon, which may be due to progression of the underlying disease or to diminished responsiveness to the

drug, is known as secondary failure, to distinguish it from primary failure in which the drug is ineffective during initial therapy. Should secondary failure occur with JANUVIA[®], therapeutic alternatives should be considered.

Hepatic/Biliary/Pancreatic

Hepatic: There are limited clinical experiences in patients with moderate hepatic impairment and no clinical experience in patients with severe hepatic impairment. Use in patients with severe hepatic impairment is not recommended (see [DOSAGE AND ADMINISTRATION](#) and [ACTION AND CLINICAL PHARMACOLOGY](#)).

Pancreatitis: There have been reports of acute pancreatitis, including fatal and non-fatal hemorrhagic or necrotizing pancreatitis, in patients taking JANUVIA[®]. In a long-term cardiovascular outcomes trial (see [ADVERSE REACTIONS](#) and [CLINICAL TRIALS](#)), there were two adjudication-confirmed deaths due to acute pancreatitis in patients treated with JANUVIA[®] compared to none in the placebo group. After initiation of JANUVIA[®], patients should be observed carefully for signs and symptoms of pancreatitis. If pancreatitis is suspected, JANUVIA[®] should promptly be discontinued and appropriate management should be initiated. Risk factors for pancreatitis include a history of: pancreatitis, gallstones, alcoholism, or hypertriglyceridemia.

Immune

Hypersensitivity Reactions: There have been post-marketing reports of serious hypersensitivity reactions in patients treated with JANUVIA[®]. These reactions include anaphylaxis, angioedema, and exfoliative skin conditions including Stevens-Johnson syndrome. Onset of these reactions occurred within the first 3 months after initiation of treatment with JANUVIA[®], with some reports occurring after the first dose. If a hypersensitivity reaction is suspected, discontinue JANUVIA[®], assess for other potential causes for the event, and institute alternative treatment for diabetes (see [CONTRAINDICATIONS](#) and [ADVERSE REACTIONS](#)).

Immunocompromised Patients: A dose-related mean decrease in absolute lymphocyte count was observed with other members of this class. When clinically indicated, such as in settings of unusual or prolonged infection, lymphocyte count should be measured. The effect of sitagliptin on lymphocyte counts in patients with lymphocyte abnormalities (e.g. human immunodeficiency virus) is unknown. Immunocompromised patients, such as patients who have undergone organ transplantation or patients diagnosed with human immunodeficiency syndrome have not been studied in the sitagliptin clinical program. Therefore, the efficacy and safety profile of sitagliptin in these patients has not been established.

Monitoring and Laboratory Tests

Blood Glucose and HbA_{1c}: Response to JANUVIA[®] should be monitored by periodic measurements of blood glucose and HbA_{1c} levels.

Renal Function: Renal function must be assessed prior to initiation of JANUVIA[®] and periodically thereafter as lower dosages are recommended in patients whose estimated glomerular rate (eGFR) decreases to less than 45 mL/min/1.73 m² as well as in patients with severe renal impairment and in patients with end-stage renal disease (ESRD) requiring hemodialysis or peritoneal dialysis (see [DOSAGE AND ADMINISTRATION](#)).

Monitoring of renal function is recommended prior to and following initiation of any concomitant drug which might have an impact on renal function.

Renal

Renal-related adverse events, including acute renal failure, have been observed during clinical trials and post-marketing use of sitagliptin in patients with and without known risk factors (see [ADVERSE REACTIONS](#)).

Renal function must be assessed prior to initiation of JANUVIA[®] and periodically thereafter. Since JANUVIA[®] is renally excreted and sitagliptin exposure is increased in patients with renal impairment, a dose adjustment of JANUVIA[®] is required in patients with an estimated glomerular filtration rate (eGFR) less than 45 mL/min/1.73 m² (see [WARNINGS AND PRECAUTIONS, Monitoring and Laboratory Tests, DOSAGE AND ADMINISTRATION](#) and [ACTION AND CLINICAL PHARMACOLOGY](#)). Caution should be used to ensure that the correct dose of JANUVIA[®] is prescribed for patients with moderate (eGFR \geq 30 mL/min/1.73 m² to <45 mL/min/1.73 m²) or severe (eGFR <30 mL/min/1.73 m²) renal impairment, as well as in patients with ESRD requiring hemodialysis or peritoneal dialysis (see [DOSAGE AND ADMINISTRATION](#)).

Skin

With other members of this class, ulcerative and necrotic skin lesions have been reported in monkeys in non-clinical toxicology studies. There is limited experience in patients with diabetic skin complications. In keeping with routine care of the diabetic patient, monitoring for skin disorders is recommended.

Bullous Pemphigoid: Post-marketing cases of bullous pemphigoid requiring hospitalization have been reported with the use of dipeptidyl peptidase 4 (DPP-4) inhibitors, including JANUVIA[®]. In reported cases, patients typically recovered with topical or systemic immunosuppressive treatment and discontinuation of the DPP-4 inhibitor. Tell patients to report development of blisters or erosions while receiving JANUVIA[®]. If bullous pemphigoid is suspected, JANUVIA[®] should be discontinued and referral to a dermatologist should be considered for diagnosis and appropriate treatment.

Special Populations

Pregnant Women: JANUVIA[®] is not recommended for use in pregnancy. There are very limited data for the use of sitagliptin in pregnant women in clinical studies, including no adequate and well-controlled studies in this population; therefore, the safety of JANUVIA[®] in pregnant women is not known (see [TOXICOLOGY](#)).

Nursing Women: Sitagliptin is secreted in the milk of lactating rats. It is not known whether sitagliptin is secreted in human milk. Therefore, JANUVIA[®] should not be used by a woman who is nursing.

Pediatrics (<18 years of age): Safety and effectiveness of JANUVIA[®] in pediatric patients have not been established. Therefore, JANUVIA[®] should not be used in this population.

Geriatrics (≥65 years of age): In clinical studies, no overall differences in safety or effectiveness were observed between subjects 65 years and over and younger subjects. While this and other reported clinical experience have not identified differences in responses between the geriatric and younger patients, greater sensitivity of some older individuals cannot be ruled out.

Because sitagliptin is excreted by the kidney and geriatric patients are more likely to have decreased renal function, care should be taken in dose selection and should be based on careful and regular monitoring of renal function (see [DOSAGE AND ADMINISTRATION](#) and [ACTION AND CLINICAL PHARMACOLOGY](#)).

ADVERSE REACTIONS

Adverse Drug Reaction Overview

JANUVIA[®] was generally well tolerated in controlled clinical studies as monotherapy and as part of combination therapy with metformin or combination therapy with metformin and a sulfonylurea agent, or add-on combination therapy with insulin (with or without metformin) or as add-on combination therapy with pioglitazone (with or without metformin).

The incidences of serious adverse reactions and discontinuation of therapy due to clinical adverse reactions were generally similar to placebo. The most frequent adverse events in trials of JANUVIA[®] as monotherapy (placebo-controlled) and as add-on combination therapy with metformin (reported regardless of causality and more common with JANUVIA[®] than other treatments) was nasopharyngitis. The most frequent adverse events with JANUVIA[®] as add-on combination therapy with metformin and a sulfonylurea agent, or as add-on combination therapy with insulin (with or without metformin), was hypoglycemia.

Clinical Trial Adverse Drug Reactions

Because clinical trials are conducted under very specific conditions the adverse reaction rates observed in the clinical trials may not reflect the rates observed in practice and should not be compared to the rates in the clinical trials of another drug. Adverse drug reaction information from clinical trials is useful for identifying drug-related adverse events and for approximating rates.

Monotherapy:

Two placebo-controlled monotherapy studies, one of 18- and one of 24-week duration, included patients treated with JANUVIA[®] 100 mg once daily and patients given placebo. Adverse events, reported regardless of causality assessment, in ≥1% of patients in these two studies pooled are shown in Table 1.

Table 1 – Adverse Events ≥1% in Any Treatment Group (regardless of causality) Reported in Patients Treated with JANUVIA® 100 mg or Placebo in Pooled 18 and 24-Week Placebo-Controlled, Double-Blind Clinical Trials of JANUVIA® as Monotherapy

Body system/Organ class Adverse event	Number of patients (%)	
	Sitagliptin 100 mg n=443	Placebo n=363
Eye disorders		
Conjunctivitis	3 (0.7)	4 (1.1)
Gastrointestinal disorders		
Abdominal pain	5 (1.1)	6 (1.7)
Constipation	13 (2.9)	5 (1.4)
Diarrhea	19 (4.3)	10 (2.8)
Gastritis	2 (0.5)	4 (1.1)
Nausea	7 (1.6)	3 (0.8)
Vomiting	3 (0.7)	4 (1.1)
General disorders and administration site conditions		
Fatigue	5 (1.1)	9 (2.5)
Edema peripheral	7 (1.6)	4 (1.1)
Pain	0 (0.0)	4 (1.1)
Infections and infestations		
Bronchitis	5 (1.1)	6 (1.7)
Gastroenteritis	6 (1.4)	4 (1.1)
Influenza	19 (4.3)	16 (4.4)
Nasopharyngitis	23 (5.2)	12 (3.3)
Pharyngitis	5 (1.1)	1 (0.3)
Sinusitis	6 (1.4)	9 (2.5)
Upper respiratory tract infection	29 (6.5)	24 (6.6)
Urinary tract infection	8 (1.8)	9 (2.5)
Viral infection	2 (0.5)	4 (1.1)
Viral upper respiratory tract infection	5 (1.1)	1 (0.3)
Injury, poisoning and procedural complications		
Limb injury	3 (0.7)	4 (1.1)
Investigations		
Blood glucose increased	7 (1.6)	13 (3.6)
Metabolism and nutrition disorders		
Hyperglycemia	5 (1.1)	7 (1.9)
Hypoglycemia	5 (1.1)	2 (0.6)
Musculoskeletal and connective tissue disorders		
Arthralgia	4 (0.9)	9 (2.5)
Back pain	14 (3.2)	12 (3.3)
Muscle spasm	6 (1.4)	4 (1.1)
Myalgia	6 (1.4)	4 (1.1)
Neck pain	1 (0.2)	4 (1.1)
Osteoarthritis	5 (1.1)	1 (0.3)
Pain in extremity	7 (1.6)	6 (1.7)
Nervous system disorders		

Table 1 – Adverse Events $\geq 1\%$ in Any Treatment Group (regardless of causality) Reported in Patients Treated with JANUVIA[®] 100 mg or Placebo in Pooled 18 and 24-Week Placebo-Controlled, Double-Blind Clinical Trials of JANUVIA[®] as Monotherapy

Body system/Organ class Adverse event	Number of patients (%)	
	Sitagliptin 100 mg n=443	Placebo n=363
Dizziness	7 (1.6)	8 (2.2)
Headache	18 (4.1)	14 (3.9)
Paresthesia	4 (0.9)	4 (1.1)
Psychiatric disorders		
Anxiety	3 (0.7)	4 (1.1)
Insomnia	4 (0.9)	6 (1.7)
Respiratory, thoracic and mediastinal disorders		
Cough	8 (1.8)	10 (2.8)
Vascular disorders		
Hypertension	8 (1.8)	7 (1.9)

In a 24-week study which compared sitagliptin and metformin, adverse events, reported regardless of causality assessment, in $\geq 1\%$ of patients are shown in Table 2.

Table 2 – Adverse Events $\geq 1\%$ in Any Treatment Group (regardless of causality) Reported in Patients in 24-Week Active-Controlled, Double-Blind Clinical Trial of JANUVIA[®] as Monotherapy

Body system/Organ class Adverse event	Number of patients (%)	
	Sitagliptin 100 mg n=528	Metformin n=522
Gastrointestinal disorders		
Abdominal pain	4 (0.8)	6 (1.1)
Abdominal pain upper	5 (0.9)	12 (2.3)
Constipation	9 (1.7)	5 (1.0)
Diarrhea	19 (3.6)	57 (10.9)
Dyspepsia	1 (0.2)	7 (1.3)
Gastritis	6 (1.1)	11 (2.1)
Nausea	6 (1.1)	16 (3.1)
Vomiting	2 (0.4)	7 (1.3)
General disorders and administration site conditions		
Fatigue	6 (1.1)	6 (1.1)
Infections and infestations		
Bronchitis	4 (0.8)	7 (1.3)
Influenza	12 (2.3)	11 (2.1)
Nasopharyngitis	10 (1.9)	17 (3.3)
Upper respiratory tract infection	5 (0.9)	11 (2.1)
Urinary tract infection	3 (0.6)	13 (2.5)
Metabolism and nutrition disorders		
Hypoglycemia	9 (1.7)	18 (3.4)
Musculoskeletal and connective		

Table 2 – Adverse Events $\geq 1\%$ in Any Treatment Group (regardless of causality) Reported in Patients in 24-Week Active-Controlled, Double-Blind Clinical Trial of JANUVIA[®] as Monotherapy

Body system/Organ class Adverse event	Number of patients (%)	
	Sitagliptin 100 mg n=528	Metformin n=522
tissue disorders		
Back pain	9 (1.7)	9 (1.7)
Pain in extremity	7 (1.3)	2 (0.4)
Nervous system disorders		
Dizziness	9 (1.7)	5 (1.0)
Headache	17 (3.2)	17 (3.3)
Respiratory, thoracic and mediastinal disorders		
Cough	1 (0.2)	8 (1.5)
Vascular disorders		
Hypertension	12 (2.3)	4 (0.8)

In two monotherapy studies, diarrhea was the only drug-related adverse reaction reported by the investigator that occurred with an incidence $\geq 1\%$ in patients receiving JANUVIA[®] 100 mg (1.1%) and greater than in patients receiving placebo (0.3%).

Combination Therapy – Sitagliptin Add-on to metformin:

In a 24-week placebo-controlled clinical study of patients receiving sitagliptin (100 mg daily) as add-on combination therapy with metformin the incidence of adverse events reported regardless of causality assessment, in $\geq 1\%$ of patients are shown in Table 3.

Table 3 – Adverse Events $\geq 1\%$ in Any treatment Group (regardless of causality) Reported in Patients in a 24-week Placebo-Controlled, Double-Blind Clinical Trial of JANUVIA[®] in Add-on Combination Use with Metformin

Body system/Organ class Adverse event	Number of patients (%)	
	Sitagliptin 100 mg + Metformin n=464	Placebo + Metformin n=237
Ear and labyrinth disorders		
Vertigo	5 (1.1)	4 (1.7)
Eye disorders		
Vision blurred	1 (0.2)	3 (1.3)
Gastrointestinal disorders		
Abdominal pain	2 (0.4)	6 (2.5)
Abdominal pain upper	6 (1.3)	2 (0.8)
Constipation	5 (1.1)	1 (0.4)
Diarrhea	11 (2.4)	6 (2.5)
Nausea	6 (1.3)	2 (0.8)
Vomiting	5 (1.1)	2 (0.8)
General disorders and administration site conditions		
Fatigue	2 (0.4)	4 (1.7)
Edema peripheral	4 (0.9)	3 (1.3)

Table 3 – Adverse Events ≥1% in Any treatment Group (regardless of causality) Reported in Patients in a 24-week Placebo-Controlled, Double-Blind Clinical Trial of JANUVIA® in Add-on Combination Use with Metformin

Body system/Organ class Adverse event	Number of patients (%)	
	Sitagliptin 100 mg + Metformin n=464	Placebo + Metformin n=237
Infections and infestations		
Bronchitis	12 (2.6)	6 (2.5)
Bronchitis acute	2 (0.4)	3 (1.3)
Gastroenteritis	4 (0.9)	5 (2.1)
Influenza	19 (4.1)	12 (5.1)
Nasopharyngitis	19 (4.1)	7 (3.0)
Pharyngitis	6 (1.3)	1 (0.4)
Infections and infestations		
Pneumonia	5 (1.1)	0 (0.0)
Sinusitis	7 (1.5)	2 (0.8)
Tooth infection	5 (1.1)	2 (0.8)
Upper respiratory tract infection	34 (7.3)	22 (9.3)
Urinary tract infection	9 (1.9)	2 (0.8)
Injury, poisoning and procedural complications		
Contusion	5 (1.1)	1 (0.4)
Investigations		
Blood glucose increased	3 (0.6)	6 (2.5)
Metabolism and nutrition disorders		
Hyperglycemia	2 (0.4)	7 (3.0)
Hypoglycemia	6 (1.3)	5 (2.1)
Musculoskeletal and connective tissue disorders		
Arthralgia	14 (3.0)	1 (0.4)
Back pain	15 (3.2)	6 (2.5)
Muscle spasm	1 (0.2)	3 (1.3)
Myalgia	1 (0.2)	3 (1.3)
Pain in extremity	5 (1.1)	4 (1.7)
Shoulder pain	3 (0.6)	3 (1.3)
Nervous system disorders		
Dizziness	7 (1.5)	2 (0.8)
Headache	12 (2.6)	7 (3.0)
Sciatica	1 (0.2)	3 (1.3)
Sinus headache	0 (0.0)	3 (1.3)
Psychiatric disorders		
Insomnia	5 (1.1)	3 (1.3)
Renal and urinary disorders		
Nephrolithiasis	3 (0.6)	3 (1.3)
Respiratory, thoracic and mediastinal disorders		
Cough	14 (3.0)	4 (1.7)
Vascular disorders		
Hypertension	7 (1.5)	6 (2.5)

In a combination therapy study with metformin, nausea was the only drug-related adverse reaction reported by the investigator that occurred with an incidence $\geq 1\%$ in patients receiving JANUVIA[®] (1.1%) and greater than in patients receiving placebo (0.4%).

In pooled studies of up to one year duration which compared sitagliptin added to metformin or a sulfonylurea agent (glipizide) added to metformin, adverse events, reported regardless of causality assessment, in $\geq 1\%$ of patients are shown in Table 4.

Table 4 – Adverse Events $\geq 1\%$ in Any Treatment Group (regardless of causality) Reported in Patients from Double-Blind Clinical Trials of JANUVIA[®] in Add-on Combination Use with Metformin in Studies Up to One Year Compared to a Sulfonylurea Agent (Glipizide)

Body system/Organ class Adverse event	Number of patients (%)	
	Sitagliptin 100 mg + Metformin n=979	Glipizide + Metformin n=748
Gastrointestinal disorders		
Abdominal pain	10 (1.0)	6 (0.8)
Abdominal pain upper	13 (1.3)	7 (0.9)
Constipation	17 (1.7)	13 (1.7)
Diarrhea	42 (4.3)	36 (4.8)
Dyspepsia	14 (1.4)	12 (1.6)
Nausea	19 (1.9)	16 (2.1)
Toothache	2 (0.2)	13 (1.7)
Vomiting	11 (1.1)	9 (1.2)
General disorders and administration site conditions		
Fatigue	20 (2.0)	8 (1.1)
Non-cardiac chest pain	10 (1.0)	6 (0.8)
Edema peripheral	16 (1.6)	14 (1.9)
Infections and infestations		
Bronchitis	27 (2.8)	22 (2.9)
Cellulitis	7 (0.7)	10 (1.3)
Gastroenteritis	19 (1.9)	13 (1.7)
Gastroenteritis viral	8 (0.8)	9 (1.2)
Herpes zoster	4 (0.4)	8 (1.1)
Influenza	35 (3.6)	32 (4.3)
Nasopharyngitis	75 (7.7)	49 (6.6)
Sinusitis	20 (2.0)	12 (1.6)
Upper respiratory tract infection	78 (8.0)	70 (9.4)
Urinary tract infection	41 (4.2)	21 (2.8)
Investigations		
Blood glucose decreased	5 (0.5)	16 (2.1)
Blood glucose increased	13 (1.3)	5 (0.7)
Weight increased	1 (0.1)	8 (1.1)
Metabolism and nutrition disorders		
Hyperglycemia	10 (1.0)	6 (0.8)
Hypoglycemia	32 (3.3)	217 (29.0)
Musculoskeletal and connective tissue disorders		
Arthralgia	34 (3.5)	29 (3.9)
Back pain	39 (4.0)	32 (4.3)

Table 4 – Adverse Events $\geq 1\%$ in Any Treatment Group (regardless of causality) Reported in Patients from Double-Blind Clinical Trials of JANUVIA[®] in Add-on Combination Use with Metformin in Studies Up to One Year Compared to a Sulfonylurea Agent (Glipizide)

Body system/Organ class Adverse event	Number of patients (%)	
	Sitagliptin 100 mg + Metformin n=979	Glipizide + Metformin n=748
Muscle spasms	9 (0.9)	8 (1.1)
Neck pain	4 (0.4)	8 (1.1)
Osteoarthritis	18 (1.8)	5 (0.7)
Pain in extremity	23 (2.3)	9 (1.2)
Shoulder pain	7 (0.7)	14 (1.9)
Nervous system disorders		
Dizziness	26 (2.7)	14 (1.9)
Headache	34 (3.5)	31 (4.1)
Hypoaesthesia	3 (0.3)	11 (1.5)
Psychiatric disorders		
Anxiety	13 (1.3)	7 (0.9)
Depression	10 (1.0)	7 (0.9)
Insomnia	12 (1.2)	11 (1.5)
Reproductive system and breast disorders		
Erectile dysfunction	6 (0.6)	8 (1.1)
Respiratory, thoracic and mediastinal disorders		
Cough	19 (1.9)	23 (3.1)
Pharyngolaryngeal pain	10 (1.0)	9 (1.2)
Sinus congestion	5 (0.5)	8 (1.1)
Eczema	4 (0.4)	12 (1.6)
Vascular disorders		
Hypertension	33 (3.4)	29 (3.9)

Combination Therapy: Sitagliptin Add-on to Metformin and a Sulfonylurea

In a 24-week placebo-controlled study of JANUVIA[®] 100 mg in combination with metformin and glimepiride (JANUVIA[®], N=116; placebo, N=113), the incidence of adverse events, reported regardless of causality assessment, in $\geq 1\%$ of patients are shown in Table 5. The overall incidence of adverse events with JANUVIA[®] was higher than with placebo, in part related to higher incidence of hypoglycemia (see Table 5).

Table 5 – Adverse Events $\geq 1\%$ in Any Treatment Group (regardless of causality) Reported in Patients in a 24-Week Placebo-Controlled, Double-Blind Clinical Trial of JANUVIA[®] in Add-on Combination Use with Metformin and a Sulfonylurea Agent (Glimepiride)

Body system/Organ class Adverse event	Number of patients (%)	
	Sitagliptin 100 mg + Metformin + Glimepiride n=116	Placebo + Metformin + Glimepiride n=113
Ear and Labyrinth Disorders		
Vertigo	2 (1.7)	0 (0.0)
Eye Disorders		
Diabetic retinopathy	0 (0.0)	2 (1.8)
Vision blurred	0 (0.0)	2 (1.8)
Gastrointestinal disorders		

Table 5 – Adverse Events $\geq 1\%$ in Any Treatment Group (regardless of causality) Reported in Patients in a 24-Week Placebo-Controlled, Double-Blind Clinical Trial of JANUVIA® in Add-on Combination Use with Metformin and a Sulfonylurea Agent (Glimepiride)

Body system/Organ class Adverse event	Number of patients (%)	
	Sitagliptin 100 mg + Metformin + Glimepiride n=116	Placebo + Metformin + Glimepiride n=113
Abdominal pain upper	2 (1.7)	2 (1.8)
Constipation	4 (3.4)	0 (0.0)
Diarrhea	1 (0.9)	4 (3.5)
Dyspepsia	3 (2.6)	2 (1.8)
Gastritis	0 (0.0)	4 (3.5)
Toothache	2 (1.7)	2 (1.8)
Vomiting	2 (1.7)	1 (0.9)
General disorders and administration site conditions		
Fatigue	0 (0.0)	3 (2.7)
Non-Cardiac chest pain	2 (1.7)	1 (0.9)
Pyrexia	0 (0.0)	2 (1.8)
Hepatobiliary disorders		
Cholelithiasis	0 (0.0)	2 (1.8)
Infections and infestations		
Bronchitis	2 (1.7)	2 (1.8)
Gastroenteritis	3 (2.6)	0 (0.0)
Gastroenteritis viral	2 (1.7)	2 (1.8)
Influenza	3 (2.6)	2 (1.8)
Nasopharyngitis	7 (6.0)	9 (8.0)
Pharyngitis	1 (0.9)	3 (2.7)
Pneumonia	3 (2.6)	0 (0.0)
Rhinitis	2 (1.7)	0 (0.0)
Sinusitis	1 (0.9)	2 (1.8)
Tooth abscess	2 (1.7)	1 (0.9)
Upper respiratory tract infection	8 (6.9)	9 (8.0)
Urinary tract infection	2 (1.7)	1 (0.9)
Injury, poisoning and procedural complications		
Fall	0 (0.0)	3 (2.7)
Polytraumatism	1 (0.9)	2 (1.8)
Investigations		
Blood glucose decreased	0 (0.0)	2 (1.8)
Metabolism and nutrition disorders		
Hypoglycemia	19 (16.4)	1 (0.9)
Musculoskeletal and connective tissue disorders		
Arthralgia	5 (4.3)	1 (0.9)
Back pain	1 (0.9)	2 (1.8)
Muscle spasms	2 (1.7)	1 (0.9)
Osteoarthritis	2 (1.7)	0 (0.0)
Pain in extremity	4 (3.4)	1 (0.9)
Shoulder pain	0 (0.0)	2 (1.8)
Nervous system disorders		

Table 5 – Adverse Events $\geq 1\%$ in Any Treatment Group (regardless of causality) Reported in Patients in a 24-Week Placebo-Controlled, Double-Blind Clinical Trial of JANUVIA[®] in Add-on Combination Use with Metformin and a Sulfonylurea Agent (Glimepiride)

Body system/Organ class Adverse event	Number of patients (%)	
	Sitagliptin 100 mg + Metformin + Glimepiride n=116	Placebo + Metformin + Glimepiride n=113
Dizziness	3 (2.6)	1 (0.9)
Headache	8 (6.9)	3 (2.7)
Hypoaesthesia	2 (1.7)	0 (0.0)
Somnolence	0 (0.0)	2 (1.8)
Respiratory, thoracic and mediastinal disorders		
Asthma	2 (1.7)	1 (0.9)
Skin and subcutaneous tissue disorders		
Pruritus	2 (1.7)	1 (0.9)
Rash	2 (1.7)	1 (0.9)
Vascular disorders		
Hypertension	2 (1.7)	0 (0.0)

In a combination therapy study with metformin and a sulfonylurea, hypoglycemia (JANUVIA[®] 13.8%; placebo 0.9%) and constipation (JANUVIA[®] 1.7%; placebo 0.0%) were the only drug-related adverse reactions reported by the investigator that occurred with an incidence $\geq 1\%$ in patients receiving JANUVIA[®] and metformin and a sulfonylurea and greater than in patients receiving placebo and metformin and a sulfonylurea.

Combination Therapy: Add-on with Insulin (with or without metformin)

In a 24-week placebo-controlled study of JANUVIA[®] 100 mg in combination with stable dose insulin (with or without metformin) (JANUVIA[®], N=322; placebo, N=319), the incidence of adverse reactions, reported regardless of causality assessment, in $\geq 1\%$ of patients are shown in Table 6. The overall incidence of adverse events with JANUVIA[®] was higher than with placebo, in part related to higher incidence of hypoglycemia (see Table 6)

Table 6 – Adverse Events $\geq 1\%$ in Any Treatment Group (regardless of causality) Reported in Patients in a 24-Week Placebo-Controlled, Double-Blind Clinical Trial of JANUVIA[®] in Add-on Combination Use with Stable Dose Insulin (With or Without Metformin)

Body system/Organ class Adverse event	Number of patients (%)	
	Sitagliptin 100 mg + Insulin (+/- Metformin) n=322	Placebo + Insulin (+/- Metformin) n=319
Gastrointestinal Disorders		
Constipation	6 (1.9)	1 (0.3)
Diarrhea	6 (1.9)	5 (1.6)
Nausea	4 (1.2)	5 (1.6)
Vomiting	5 (1.6)	2 (0.6)
Infections and infestations		
Bronchitis	6 (1.9)	5 (1.6)
Gastroenteritis	3 (0.9)	5 (1.6)
Influenza	13 (4.0)	12 (3.8)

Table 6 – Adverse Events $\geq 1\%$ in Any Treatment Group (regardless of causality) Reported in Patients in a 24-Week Placebo-Controlled, Double-Blind Clinical Trial of JANUVIA[®] in Add-on Combination Use with Stable Dose Insulin (With or Without Metformin)

Body system/Organ class Adverse event	Number of patients (%)	
	Sitagliptin 100 mg + Insulin (+/- Metformin) n=322	Placebo + Insulin (+/- Metformin) n=319
Nasopharyngitis	10 (3.1)	8 (2.5)
Sinusitis	4 (1.2)	4 (1.3)
Upper respiratory tract infection	10 (3.1)	11 (3.4)
Urinary tract infection	9 (2.8)	6 (1.9)
Investigations		
Alanine aminotransferase increased	4 (1.2)	1 (0.3)
Creatinine renal clearance decreased	5 (1.6)	0 (0.0)
Metabolism and nutrition disorders		
Hyperglycemia	5 (1.6)	2 (0.6)
Hypoglycemia	50 (15.5)	25 (7.8)
Musculoskeletal and connective tissue disorders		
Arthralgia	4 (1.2)	6 (1.9)
Back pain	6 (1.9)	2 (0.6)
Muscle spasms	3 (0.9)	5 (1.6)
Pain in extremity	6 (1.9)	3 (0.9)
Nervous system disorders		
Dizziness	5 (1.6)	3 (0.9)
Headache	9 (2.8)	3 (0.9)
Respiratory, thoracic and mediastinal disorders		
Cough	5 (1.6)	3 (0.9)

In a combination therapy study with stable dose insulin (with or without metformin), hypoglycemia (JANUVIA[®] 9.6%; placebo 5.3%), influenza (JANUVIA[®] 1.2%; placebo 0.3%), and headache (JANUVIA[®] 1.2%; placebo 0.0%) were the only drug-related adverse reactions reported by the investigator that occurred with an incidence $\geq 1\%$ in patients receiving JANUVIA[®] and greater than in patients receiving placebo.

Combination Therapy: Sitagliptin Add-on to Pioglitazone (with or without Metformin)

In a 24-week placebo-controlled clinical study of patients receiving sitagliptin (100 mg daily) as add-on combination therapy with pioglitazone, the incidence of adverse events reported regardless of causality assessment, in $\geq 1\%$ of patients are shown in Table 7.

Table 7 – Adverse Events ≥1% in Any Treatment Group (regardless of causality) Reported in Patients in a 24-Week Placebo-Controlled, Double-Blind Clinical Trial of JANUVIA® in Add-on Combination with Pioglitazone

Body system/Organ class Adverse event	Number of patients (%)	
	Sitagliptin 100 mg + Pioglitazone n=175	Placebo + Pioglitazone n=178
Ear and Labyrinth Disorders		
Vertigo	0 (0.0)	3 (1.7)
Eye Disorders		
Cataract	0 (0.0)	3 (1.7)
Vision Blurred	2 (1.1)	1 (0.6)
Gastrointestinal disorders		
Abdominal pain	2 (1.1)	0 (0.0)
Abdominal pain lower	2 (1.1)	0 (0.0)
Abdominal pain upper	2 (1.1)	0 (0.0)
Constipation	2 (1.1)	2 (1.1)
Diarrhea	3 (1.7)	2 (1.1)
Dyspepsia	2 (1.1)	1 (0.6)
Flatulence	2 (1.1)	0 (0.0)
Nausea	2 (1.1)	0 (0.0)
General disorders and administration site conditions		
Chest pain	2 (1.1)	0 (0.0)
Fatigue	1 (0.6)	3 (1.7)
Feeling abnormal	2 (1.1)	0 (0.0)
Oedema	2 (1.1)	1 (0.6)
Oedema peripheral	7 (4.0)	5 (2.8)
Hepatobiliary Disorders		
Cholelithiasis	0 (0.0)	2 (1.1)
Infections and infestations		
Bronchitis	3 (1.7)	1 (0.6)
Cellulitis	2 (1.1)	1 (0.6)
Influenza	6 (3.4)	5 (2.8)
Nasopharyngitis	7 (4.0)	7 (3.9)
Pharyngitis	2 (1.1)	2 (1.1)
Pneumonia	0 (0.0)	3 (1.7)
Pyoderma	2 (1.1)	0 (0.0)
Sinusitis	2 (1.1)	2 (1.1)
Tinea Pedis	2 (1.1)	0 (0.0)
Upper respiratory tract infection	11 (6.3)	6 (3.4)
Urinary tract infection	1 (0.6)	2 (1.1)
Viral infection	2 (1.1)	1 (0.6)
Injury, poisoning and procedural complications		
Joint sprain	2 (1.1)	2 (1.1)
Investigations		
Blood glucose increased	1 (0.6)	2 (1.1)
Weight increased	5 (2.9)	5 (2.8)
Metabolism and nutrition disorders		
Hypoglycemia	2 (1.1)	0 (0.0)

Table 7 – Adverse Events $\geq 1\%$ in Any Treatment Group (regardless of causality) Reported in Patients in a 24-Week Placebo-Controlled, Double-Blind Clinical Trial of JANUVIA[®] in Add-on Combination with Pioglitazone

Body system/Organ class Adverse event	Number of patients (%)	
	Sitagliptin 100 mg + Pioglitazone n=175	Placebo + Pioglitazone n=178
Musculoskeletal and connective tissue disorders		
Arthralgia	5 (2.9)	4 (2.2)
Back pain	3 (1.7)	5 (2.8)
Musculoskeletal stiffness	2 (1.1)	0 (0.0)
Myalgia	0 (0.0)	2 (1.1)
Neck pain	0 (0.0)	2 (1.1)
Osteoarthritis	3 (1.7)	3 (1.7)
Pain in extremity	4 (2.3)	3 (1.7)
Tendonitis	0 (0.0)	2 (1.1)
Nervous system disorders		
Dizziness	3 (1.7)	2 (1.1)
Headache	9 (5.1)	7 (3.9)
Psychiatric disorders		
Anxiety	1 (0.6)	2 (1.1)
Depression	4 (2.3)	2 (1.1)
Libido decreased	2 (1.1)	0 (0.0)
Respiratory, thoracic and mediastinal disorders		
Cough	3 (1.7)	3 (1.7)
Skin and subcutaneous tissue disorders		
Dermatitis allergic	0 (0.0)	2 (1.1)

In a combination therapy study with pioglitazone, hypoglycemia (JANUVIA[®] 1.1%; placebo 0.0%), flatulence (JANUVIA[®] 1.1%; placebo 0.0%), weight increase (JANUVIA[®] 2.3%; placebo 1.7%), and headache (JANUVIA[®] 1.7%; placebo 1.1%) were the only drug-related adverse reactions reported by the investigator that occurred with an incidence $\geq 1\%$ in patients receiving JANUVIA[®] and greater than in patients receiving placebo.

In a 26-week placebo-controlled clinical study of patients receiving sitagliptin (100 mg daily) as add-on combination therapy with metformin and pioglitazone, the incidence of adverse events reported regardless of causality assessment, in $\geq 1\%$ of patients are shown in Table 8.

Table 8 – Adverse Events $\geq 1\%$ in Any Treatment Group (regardless of causality) Reported in Patients in a 26-Week Placebo-Controlled, Double-Blind Clinical Trial of JANUVIA[®] in Add-on Combination Use with Metformin and Pioglitazone

Body system/Organ class Adverse event	Number of patients (%)	
	Sitagliptin 100 mg + Metformin + Pioglitazone n=157	Placebo + Metformin + Pioglitazone n=156
Ear and Labyrinth Disorders		
Cerumen impaction	2 (1.3)	1 (0.6)

Table 8 – Adverse Events ≥1% in Any Treatment Group (regardless of causality) Reported in Patients in a 26-Week Placebo-Controlled, Double-Blind Clinical Trial of JANUVIA® in Add-on Combination Use with Metformin and Pioglitazone

Body system/Organ class Adverse event	Number of patients (%)	
	Sitagliptin 100 mg + Metformin + Pioglitazone n=157	Placebo + Metformin + Pioglitazone n=156
Eye Disorders		
Conjunctivitis	3 (1.9)	1 (0.6)
Ocular hyperaemia	0 (0.0)	2 (1.3)
Gastrointestinal disorders		
Abdominal pain upper	1 (0.6)	2 (1.3)
Constipation	2 (1.3)	1 (0.6)
Dental Caries	2 (1.3)	1 (0.6)
Diarrhea	3 (1.9)	4 (2.6)
Dyspepsia	1 (0.6)	2 (1.3)
Gastritis	0 (0.0)	2 (1.3)
Toothache	2 (1.3)	0 (0.0)
Vomiting	2 (1.3)	0 (0.0)
General disorders and administration site conditions		
Fatigue	0 (0.0)	2 (1.3)
Oedema peripheral	3 (1.9)	7 (4.5)
Infections and infestations		
Bronchitis	3 (1.9)	1 (0.6)
Cellulitis	2 (1.3)	0 (0.0)
Gastroenteritis	2 (1.3)	0 (0.0)
Gastroenteritis viral	2 (1.3)	0 (0.0)
Herpes zoster	2 (1.3)	0 (0.0)
Influenza	2 (1.3)	3 (1.9)
Nasopharyngitis	5 (3.2)	5 (3.2)
Tooth abscess	0 (0.0)	2 (1.3)
Upper respiratory tract infection	13 (8.3)	14 (9.0)
Urinary tract infection	5 (3.2)	6 (3.8)
Injury, poisoning and procedural complications		
Muscle strain	2 (1.3)	0 (0.0)
Investigations		
Blood creatine phosphokinase increased	1 (0.6)	3 (1.9)
Glomerular filtration rate decreased	2 (1.3)	0 (0.0)
Lymphocyte count increased	2 (1.3)	1 (0.6)
Neutrophil count decreased	2 (1.3)	1 (0.6)
Metabolism and nutrition disorders		
Hyperglycemia	2 (1.3)	2 (1.3)
Hypoglycemia	10 (6.4)	7 (4.5)
Musculoskeletal and connective tissue disorders		
Arthralgia	2 (1.3)	3 (1.9)
Back pain	7 (4.5)	4 (2.6)
Muscle spasms	2 (1.3)	0 (0.0)
Musculoskeletal pain	3 (1.9)	4 (2.6)
Pain in extremity	5 (3.2)	2 (1.3)

Table 8 – Adverse Events $\geq 1\%$ in Any Treatment Group (regardless of causality) Reported in Patients in a 26-Week Placebo-Controlled, Double-Blind Clinical Trial of JANUVIA[®] in Add-on Combination Use with Metformin and Pioglitazone

Body system/Organ class Adverse event	Number of patients (%)	
	Sitagliptin 100 mg + Metformin + Pioglitazone n=157	Placebo + Metformin + Pioglitazone n=156
Nervous system disorders		
Headache	1 (0.6)	2 (1.3)
Psychiatric disorders		
Depression	4 (2.5)	1 (0.6)
Stress	2 (1.3)	0 (0.0)
Respiratory, thoracic and mediastinal disorders		
Cough	2 (1.3)	2 (1.3)
Oropharyngeal pain	2 (1.3)	0 (0.0)
Rhinitis allergic	2 (1.3)	0 (0.0)

In a combination therapy study with pioglitazone and metformin, hypoglycemia (JANUVIA[®] 3.2%; placebo 1.9%) was the only drug-related adverse reaction reported by the investigator that occurred with an incidence $\geq 1\%$ in patients receiving JANUVIA[®] and greater than in patients receiving placebo.

Less Common Clinical Trial Adverse Drug Reactions $\geq 0.1\%$ and $< 1\%$ (Drug-Related and Greater than Placebo in Pooled Monotherapy and in Individual Placebo-Controlled Studies)

Blood and Lymphatic System Disorders: anemia

Cardiac Disorders: bundle branch block, palpitations

Eye Disorders: vision blurred

Gastrointestinal Disorders: abdominal discomfort, abdominal pain upper, abdominal tenderness, constipation, diarrhea, dry mouth, dyspepsia, flatulence, reflux esophagitis disease, frequent bowel movements, gastroesophageal reflux disease, irritable bowel syndrome, retching, salivary hypersecretion

General Disorders and Administration Site Conditions: asthenia, chest discomfort, face edema, fatigue, feeling abnormal, hunger, irritability, malaise, peripheral edema, edema, pain, pyrexia, thirst, xerosis

Hepatobiliary Disorders: hepatic steatosis

Infections and Infestations: gastric ulcer helicobacter, genital abscess, helicobacter gastritis, localized infection, oropharyngeal candidiasis, sinusitis, upper respiratory tract infection, urinary tract infection

Investigations: alanine aminotransferase increased, aspartate aminotransferase increased, blood glucose decreased, blood glucose increased, blood pressure decreased, blood pressure increased, creatinine renal clearance decreased, glomerular filtration rate decreased, white blood cell count increased

Metabolism and Nutrition Disorders: decreased appetite, hypoglycemia

Musculoskeletal and Connective Tissue Disorders: muscle fatigue, muscle tightness

Nervous System Disorders: coordination abnormal, dizziness, headache, migraine, neuropathy peripheral, parosmia, somnolence

Psychiatric Disorders: anxiety, depression, insomnia, libido decreased

Renal and Urinary Disorders: renal disorders

Reproductive System and Breast Disorders: balanoposthitis, dysmenorrhea, erectile dysfunction

Respiratory, Thoracic and Mediastinal Disorders: cough

Skin and Subcutaneous Tissue Disorders: angioneurotic oedema, dermatitis acneiform, dry skin, erythema, exanthem, hyperhidrosis, leukocytoclastic vasculitis, nail disorder, prurigo, pruritus generalized, rash, rash macular, rosacea, urticaria

Vascular Disorders: orthostatic hypotension

Atrial fibrillation/atrial flutter: In a pooled analysis of randomized clinical trials, the pooled terms atrial fibrillation/atrial flutter were observed at an incidence rate of 0.45 events per 100 patient-years in the sitagliptin-exposed group compared to 0.28 events per 100 patient-years in the non-exposed group.

TECOS Cardiovascular Safety Study:

For details pertaining to study design and patient population, see [CLINICAL TRIALS, TECOS Cardiovascular Safety Study](#).

The incidence of adjudication-confirmed pancreatitis events was higher in the JANUVIA[®] group (0.3%) compared to the placebo group (0.2%). The JANUVIA[®] group experienced a greater number of severe cases of pancreatitis including two confirmed deaths due to pancreatitis, compared to none in the placebo group.

Among patients who were using insulin and/or a sulfonylurea at baseline, the incidence of severe hypoglycemia was 2.7% in patients treated with JANUVIA[®] and 2.5% in patients treated with placebo; among patients who were not using insulin and/or a sulfonylurea at baseline, the incidence of severe hypoglycemia was 1.0% in patients treated with JANUVIA[®] and 0.7% in placebo-treated patients.

Abnormal Hematologic and Clinical Chemistry Findings

The incidence of laboratory adverse experiences was similar in patients treated with JANUVIA[®] 100 mg compared to patients treated with placebo. In most clinical studies, a slight decrease in alkaline phosphatase and small increases in uric acid and white blood cell (WBC) count (due to an increase in neutrophils) were observed. In active comparator studies versus metformin or versus a sulfonylurea agent (glipizide) similar changes were seen in alkaline phosphatase and uric acid.

Mean Change from Baseline (Standard Error)				
Study	Treatment Group	Alkaline Phosphatase (IU/L)	Uric Acid (mg/dL)	WBC (cell/microl)
Placebo-controlled (monotherapy) ¹	Sitagliptin	-5.3 (0.5)	0.26 (0.04)	320.2 (71.7)
	Placebo	-0.8 (0.5)	-0.05 (0.05)	58.6 (80.0)
Active-controlled (monotherapy) ²	Sitagliptin	-3.9 (0.5)	-0.0 (0.0)	220.4 (77.7)
	Metformin	-4.7 (0.5)	0.1 (0.0)	184.7 (66.6)
Placebo-controlled (add-on to metformin) ³	Sitagliptin	-3.1 (0.4)	0.17 (0.04)	346.0 (64.3)
	Placebo	-1.3 (0.7)	0.05 (0.06)	142.4 (98.8)
Active-controlled (add-on to metformin) ⁴	Sitagliptin	-5.7 (0.5)	0.21 (0.05)	207.8 (67.4)
	Glipizide	-3.4 (0.5)	0.20 (0.05)	86.0 (62.5)

¹ pooled data from studies 3 and 4; see [CLINICAL TRIALS](#), Table 10

² study 5; see [CLINICAL TRIALS](#), Table 10

³ study 1; see [CLINICAL TRIALS](#), Table 10

⁴ study 2; see [CLINICAL TRIALS](#), Table 10

In a combination therapy study with stable dose insulin (with or without metformin), a greater proportion of patients was observed to have a decrease in hemoglobin ≥ 1.5 g/dL in the sitagliptin group (6.0%) compared with the placebo group (2.1%). No adverse experiences of anemia or hemoglobin decreased were reported in the sitagliptin group.

Post-Marketing Adverse Drug Reactions

Because these reactions are reported voluntarily from a population of uncertain size, it is generally not possible to reliably estimate their frequency or establish a causal relationship to drug exposure.

Gastrointestinal disorders: acute pancreatitis, including fatal and non-fatal hemorrhagic and necrotizing pancreatitis (see [WARNINGS AND PRECAUTIONS](#)); vomiting

Immune system disorders: hypersensitivity reactions including anaphylaxis, angioedema, rash, urticaria, cutaneous vasculitis, and exfoliative skin conditions, including Stevens-Johnson syndrome (see [CONTRAINDICATIONS](#) and [WARNINGS AND PRECAUTIONS](#))

Musculoskeletal and connective tissue disorders: arthralgia, myalgia, pain in extremity, back pain

Renal and urinary disorders: worsening renal function, including acute renal failure (sometimes requiring dialysis) (see [WARNINGS AND PRECAUTIONS](#))

Skin and subcutaneous tissue disorders: pruritus, bullous pemphigoid (see [WARNINGS AND PRECAUTIONS](#))

DRUG INTERACTIONS

Overview

***In Vitro* Assessment of Drug Interactions:** Sitagliptin is not an inhibitor of CYP isozymes CYP3A4, 2C8, 2C9, 2D6, 1A2, 2C19 or 2B6, and is not an inducer of CYP3A4. Sitagliptin is a p-glycoprotein substrate, but does not inhibit p-glycoprotein mediated transport of digoxin. Based on these results, sitagliptin is considered unlikely to cause interactions with other drugs that utilize these pathways.

Sitagliptin is not extensively bound to plasma proteins. Therefore, the propensity of sitagliptin to be involved in clinically meaningful drug-drug interactions mediated by plasma protein binding displacement is very low.

Drug-Drug Interactions

In clinical studies, as described below, sitagliptin did not meaningfully alter the pharmacokinetics of metformin, glyburide, simvastatin, rosiglitazone, warfarin, or oral contraceptives, providing *in vivo* evidence of a low propensity for causing drug interactions with substrates of CYP3A4, CYP2C8, CYP2C9, and organic cationic transporter (OCT). Multiple doses of sitagliptin slightly increased digoxin concentrations; however, these increases are not considered likely to be clinically meaningful and are not attributed to a specific mechanism.

Effects of other drugs on the pharmacokinetics of sitagliptin

Metformin: Co-administration of multiple twice-daily doses of metformin with sitagliptin did not meaningfully alter the pharmacokinetics of sitagliptin in patients with type 2 diabetes.

Cyclosporine: A study was conducted to assess the effect of cyclosporine, a potent inhibitor of p-glycoprotein, on the pharmacokinetics of sitagliptin. Co-administration of a single 100 mg oral dose of JANUVIA[®] and a single 600 mg oral dose of cyclosporine increased the area under the plasma concentration versus time curve (AUC) and C_{max} of sitagliptin by approximately 29% and 68%, respectively. These modest changes in sitagliptin pharmacokinetics were not considered to be clinically meaningful. The renal clearance of sitagliptin was also not meaningfully altered. Therefore, meaningful interactions would not be expected with other p-glycoprotein inhibitors.

Effects of sitagliptin on the pharmacokinetics of other drugs

Metformin: Co-administration of multiple twice-daily doses of sitagliptin with metformin, an OCT substrate, did not meaningfully alter the pharmacokinetics of metformin or JANUVIA[®] in patients with type 2 diabetes. Therefore, sitagliptin is not an inhibitor of OCT-mediated transport.

Sulfonylureas: Single-dose pharmacokinetics of glyburide, a CYP2C9 substrate, were not meaningfully altered in subjects receiving multiple doses of sitagliptin. Clinically meaningful interactions would not be expected with other sulfonylureas (e.g., glipizide, tolbutamide, and glimepiride) which, like glyburide, are primarily eliminated by CYP2C9.

Simvastatin: Single-dose pharmacokinetics of simvastatin, a CYP3A4 substrate, were not meaningfully altered in subjects receiving multiple daily doses of sitagliptin. Therefore, sitagliptin is not an inhibitor of CYP3A4-mediated metabolism.

Thiazolidinediones: Single-dose pharmacokinetics of rosiglitazone were not meaningfully altered in subjects receiving multiple daily doses of sitagliptin. Therefore, sitagliptin is not an inhibitor of CYP2C8-mediated metabolism. Clinically meaningful interactions with pioglitazone are not expected because pioglitazone predominantly undergoes CYP2C8- or CYP3A4-mediated metabolism.

Warfarin: Multiple daily doses of sitagliptin did not meaningfully alter the pharmacokinetics, as assessed by measurement of S(-) or R(+) warfarin enantiomers, or pharmacodynamics (as assessed

by measurement of prothrombin International Normalized Ratio) of a single-dose of warfarin. Since S(-) warfarin is primarily metabolized by CYP2C9, these data also support the conclusion that sitagliptin is not a CYP2C9 inhibitor.

Oral Contraceptives: Co-administration with sitagliptin did not meaningfully alter the steady state pharmacokinetics of norethindrone or ethinyl estradiol.

Digoxin: Sitagliptin had a minimal effect on the pharmacokinetics of digoxin. Following administration of 0.25 mg digoxin concomitantly with 100 mg of JANUVIA[®] daily for 10 days, the plasma AUC of digoxin was increased by 11%, and the plasma C_{max} by 18%. These increases are not considered likely to be clinically meaningful. No dosage adjustment of digoxin or JANUVIA[®] is recommended.

Drug-Food Interactions

There are no known interactions with food.

Drug-Herb Interactions

Interactions with herbal products have not been established.

Drug-Laboratory Interactions

Interactions with laboratory tests have not been established.

Drug-Lifestyle Interactions

Effects of Smoking, Alcohol, and Diet: The effects of smoking, diet, and alcohol use on the pharmacokinetics of JANUVIA[®] have not been specifically studied.

Effects on Ability to Drive and Use Machines: No formal studies have been conducted with JANUVIA[®] on the effects on the ability to drive and use machines. However, patients should be warned about driving a vehicle or operating machinery under conditions where a risk of hypoglycemia is present (see [WARNINGS AND PRECAUTIONS](#)). When JANUVIA[®] is used in combination with metformin and a sulfonylurea, or in combination with insulin (with or without metformin), patients should be advised to take precautions to avoid hypoglycemia while driving or using machinery.

DOSAGE AND ADMINISTRATION

Dosing Considerations

JANUVIA[®] can be taken with or without food.

Concomitant Use with Insulin or an Insulin Secretagogue (e.g., Sulfonylurea)

When JANUVIA[®] is used in combination with metformin and a sulfonylurea or with insulin (with or without metformin), a lower dose of the insulin secretagogue or insulin may be considered to reduce the risk of hypoglycemia (see [WARNINGS AND PRECAUTIONS](#) and [ADVERSE REACTIONS](#)).

Recommended Dose and Dosage Adjustment

The recommended dose of JANUVIA[®] is **100 mg** once daily as monotherapy or as combination therapy with metformin, with metformin and a sulfonylurea, with insulin (with or without metformin), or with pioglitazone (with or without metformin).

Renal Impairment: JANUVIA[®] is renally excreted. Renal function must be assessed prior to initiation of JANUVIA[®] and periodically thereafter because, there is a dosage adjustment based upon renal function (see [WARNINGS AND PRECAUTIONS, Monitoring and Laboratory Tests](#)).

For patients with severe renal impairment (eGFR <30 mL/min/1.73 m²) or with end-stage renal disease (ESRD) including those requiring hemodialysis or peritoneal dialysis, the dose of JANUVIA[®] is **25 mg** once daily. JANUVIA[®] may be administered without regard to the timing of dialysis.

For patients with moderate renal impairment with an eGFR ≥30 mL/min/1.73 m² to less than 45 mL/min/1.73 m², the dose of JANUVIA[®] is **50 mg** once daily.

No dosage adjustment for JANUVIA[®] is required in patients with moderate renal impairment with an eGFR ≥45 mL/min/1.73 m² to less than 60 mL/min/1.73 m².

No dosage adjustment for JANUVIA[®] is required in patients with mild renal impairment (eGFR ≥60 mL/min/1.73 m² to <90 mL/min/1.73 m²).

When considering the use of sitagliptin in combination with another anti-diabetic product, its conditions for use in patients with renal impairment should be followed.

Hepatic Impairment: No dosage adjustment of JANUVIA[®] is necessary in patients with mild or moderate hepatic impairment. Sitagliptin has not been studied in patients with severe hepatic impairment and is not recommended for use in this population.

Pediatrics (<18 years of age): There are no data available on the use of JANUVIA[®] in patients younger than 18 years of age. Therefore, use of JANUVIA[®] in pediatric patients is not recommended.

Geriatrics (≥65 years of age): No dosage adjustment is necessary for geriatric patients. However, because sitagliptin is substantially excreted by the kidney, and because aging can be associated with reduced renal function, renal function should be assessed more frequently in elderly patients (see [WARNINGS AND PRECAUTIONS, Special Populations](#)).

Missed Dose

If a dose of JANUVIA[®] is missed, it should be taken as soon as the patient remembers. A double dose of JANUVIA[®] should not be taken on the same day.

OVERDOSAGE

For management of a suspected drug overdose, contact your regional Poison Control Centre.

In the event of an overdose, it is reasonable to employ the usual supportive measures, e.g., remove unabsorbed material from the gastrointestinal tract, employ clinical monitoring (including obtaining an electrocardiogram), and institute supportive therapy if required.

Sitagliptin is modestly dialyzable. In clinical studies, approximately 13.5% of the dose was removed over a 3- to 4-hour hemodialysis session. Prolonged hemodialysis may be considered if clinically appropriate. It is not known if sitagliptin is dialyzable by peritoneal dialysis.

ACTION AND CLINICAL PHARMACOLOGY

Mechanism of Action

JANUVIA[®] is an orally-active, potent, and highly selective inhibitor of the dipeptidyl peptidase 4 (DPP-4) enzyme for the treatment of type 2 diabetes. The DPP-4 inhibitors are a novel class of agents that act as incretin enhancers.

Incretin hormones, including glucagon-like peptide-1 (GLP-1) and glucose-dependent insulinotropic polypeptide (GIP), are released by the intestine throughout the day, and levels are increased in response to a meal. The incretins are part of an endogenous system involved in the physiologic regulation of glucose homeostasis. When blood glucose concentrations are normal or elevated, GLP-1 and GIP increase insulin synthesis and release from pancreatic beta cells by intracellular signaling pathways involving cyclic AMP. Progressive beta-cell failure is a feature characterizing the pathogenesis of type 2 diabetes. Treatment with GLP-1 or with DPP-4 inhibitors in animal models of type 2 diabetes has been demonstrated to improve beta cell responsiveness to glucose and stimulate insulin biosynthesis and release. With higher insulin levels, tissue glucose uptake is enhanced.

In addition, GLP-1 lowers glucagon secretion from pancreatic alpha cells. Decreased glucagon concentrations, along with higher insulin levels, lead to reduced hepatic glucose production, resulting in a decrease in blood glucose levels. When blood glucose concentrations are low, stimulation of insulin release and suppression of glucagon secretion by GLP-1 are not observed. GLP-1 does not impair the normal glucagon response to hypoglycemia.

The activity of GLP-1 and GIP is limited by the DPP-4 enzyme, which rapidly hydrolyzes the incretin hormones to produce inactive products. Sitagliptin prevents the hydrolysis of incretin hormones by DPP-4, thereby increasing plasma concentrations of the active forms of GLP-1 and GIP. By enhancing active incretin levels, sitagliptin increases insulin release and decreases glucagon levels in a glucose-dependent manner.

In patients with type 2 diabetes with hyperglycemia, these changes in insulin and glucagon levels lead to lower hemoglobin A_{1c} (HbA_{1c}) and lower fasting and postprandial glucose concentrations. Sitagliptin demonstrates selectivity for DPP-4, and does not inhibit the DPP-8 or DPP-9 activity

in vitro at concentrations approximating those from therapeutic doses. Inhibition of DPP-8 or DPP-9, but not DPP-4, is associated with toxicity in preclinical animal models and alteration of immune function *in vitro*.

Pharmacodynamics

In patients with type 2 diabetes, administration of single oral doses of JANUVIA[®] leads to inhibition of DPP-4 enzyme activity for a 24-hour period, resulting in a 2- to 3-fold increase in circulating levels of active GLP-1 and GIP, increased plasma levels of insulin and C-peptide, decreased glucagon concentrations, reduced fasting glucose, and reduced glucose excursion following an oral glucose load or a meal.

In a study of patients with type 2 diabetes inadequately controlled on metformin monotherapy (N=26), glucose levels monitored throughout the day were significantly lower ($p < 0.001$) in patients who received sitagliptin 100 mg per day (50 mg twice daily) in combination with metformin compared with patients who received placebo with metformin (see Figure 1).

Figure 1 – 24-Hour Plasma Glucose Profile After 4-Week Treatment with Sitagliptin 50 mg BID with Metformin or Placebo with Metformin

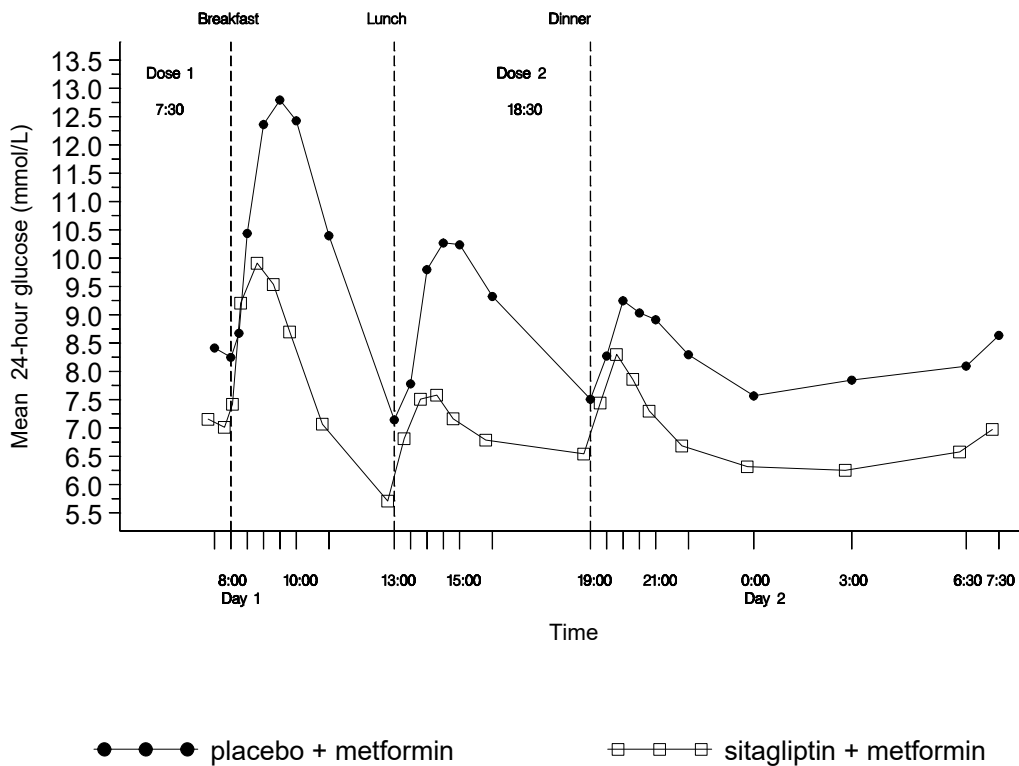

In studies with healthy subjects, JANUVIA[®] did not lower blood glucose or cause hypoglycemia, suggesting that the insulinotropic and glucagon suppressive actions of the drug are glucose dependent.

Cardiac Electrophysiology: In a randomized, placebo-controlled crossover study, 79 healthy subjects were administered a single oral dose of JANUVIA® 100 mg, JANUVIA® 800 mg (8 times the recommended dose), and placebo. At the recommended dose of 100 mg, there was no effect on the QTc interval obtained at the peak plasma concentration, or at any other time during the study. Following the 800 mg dose, the maximum increase in the placebo-corrected mean change in QTc from baseline at 3 hours post-dose was 8.0 msec (90% CI; 5.5, 10.6). At the 800 mg dose, peak sitagliptin plasma concentrations were approximately 11 times higher than the peak concentrations following a 100 mg dose.

In patients with type 2 diabetes administered JANUVIA® 100 mg (N=81) or JANUVIA® 200 mg (N=63) daily, there were no meaningful changes in QTc interval based on ECG data obtained at the time of expected peak plasma concentration.

Pharmacokinetics

Table 9 – Summary of Sitagliptin’s Pharmacokinetic Parameters in Healthy Volunteers

	C_{max} nM	t_½ (h)	AUC_{0-∞} μM•hr	Renal Clearance mL/min	Volume of distribution (L)*
Single oral dose (100 mg) mean	950	12.4	8.52	350	198

* Volume of distribution at steady state following an I.V. dose.

The pharmacokinetics of sitagliptin have been extensively characterized in healthy subjects and patients with type 2 diabetes. After oral administration of a 100 mg dose to healthy subjects, sitagliptin was rapidly absorbed, with peak plasma concentrations (median T_{max}) occurring 1 to 4 hours post-dose. Plasma AUC of sitagliptin increased in a dose-proportional manner. Following a single oral 100 mg dose to healthy volunteers, mean plasma AUC of sitagliptin was 8.52 μM•hr, C_{max} was 950 nM, and apparent terminal half-life (t_{1/2}) was 12.4 hours. Plasma AUC of sitagliptin increased approximately 14% following 100 mg doses at steady state compared to the first dose. The intra-subject and inter-subject coefficients of variation for sitagliptin AUC were small (5.8% and 15.1%). The pharmacokinetics of sitagliptin were generally similar in healthy subjects and in patients with type 2 diabetes.

Absorption: The absolute bioavailability of sitagliptin is approximately 87%. Since co-administration of a high-fat meal with JANUVIA® had no effect on the pharmacokinetics, JANUVIA® may be administered with or without food.

Distribution: The mean volume of distribution at steady state following a single 100 mg intravenous dose of sitagliptin to healthy subjects is approximately 198 liters. The fraction of sitagliptin reversibly bound to plasma proteins is low (38%).

Metabolism: Sitagliptin is primarily eliminated unchanged in urine, and metabolism is a minor pathway. Approximately 79% of sitagliptin is excreted unchanged in the urine.

Following a [¹⁴C] sitagliptin oral dose, approximately 16% of the radioactivity was excreted as metabolites of sitagliptin. Six metabolites were detected at trace levels and are not expected to

contribute to the plasma DPP-4 inhibitory activity of sitagliptin. *In vitro* studies indicated that the primary enzyme responsible for the limited metabolism of sitagliptin was CYP3A4, with contribution from CYP2C8.

Excretion: Following administration of an oral [¹⁴C] sitagliptin dose to healthy subjects, approximately 100% of the administered radioactivity was eliminated in feces (13%) or urine (87%) within one week of dosing. The apparent terminal $t_{1/2}$ following a 100 mg oral dose of sitagliptin was approximately 12.4 hours and renal clearance was approximately 350 mL/min.

Elimination of sitagliptin occurs primarily via renal excretion and involves active tubular secretion. Sitagliptin is a substrate for human organic anion transporter-3 (hOAT-3), which may be involved in the renal elimination of sitagliptin. The clinical relevance of hOAT-3 in sitagliptin transport has not been established. Sitagliptin is also a substrate of p-glycoprotein, which may also be involved in mediating the renal elimination of sitagliptin. However, cyclosporine, a p-glycoprotein inhibitor, did not reduce the renal clearance of sitagliptin.

Special Populations and Conditions

Pediatrics: No studies with JANUVIA[®] have been performed in pediatric patients.

Geriatrics: Age did not have a clinically meaningful impact on the pharmacokinetics of sitagliptin based on a population pharmacokinetic analysis of Phase I and Phase II data. Elderly subjects (65 to 80 years) had approximately 19% higher plasma concentrations of sitagliptin compared to younger subjects.

Gender: Gender had no clinically meaningful effect on the pharmacokinetics of sitagliptin based on a composite analysis of Phase I pharmacokinetic data and on a population pharmacokinetic analysis of Phase I and Phase II data.

Race: Race had no clinically meaningful effect on the pharmacokinetics of sitagliptin based on a composite analysis of Phase I pharmacokinetic data and on a population pharmacokinetic analysis of Phase I and Phase II data, including subjects of White, Hispanic, Black and Asian racial groups.

Hepatic Impairment: In patients with moderate hepatic impairment (Child-Pugh score 7 to 9), mean AUC and C_{max} of sitagliptin increased approximately 21% (90% CI: 1%, 46%) and 13% (90% CI: -9%, 42%), respectively, compared to healthy matched controls following administration of a single 100 mg dose of JANUVIA[®].

Renal Impairment: A single-dose, open-label study was conducted to evaluate the pharmacokinetics of a reduced dose of JANUVIA[®] (50 mg) in patients with varying degrees of chronic renal impairment compared to normal healthy control subjects. The study included patients with mild, moderate, and severe renal impairment as well as patients with ESRD on hemodialysis. In addition, the effects of renal impairment on sitagliptin pharmacokinetics in patients with type 2 diabetes and mild, moderate or severe renal impairment (including ESRD) were assessed using population pharmacokinetic analyses. Compared to normal healthy control subjects, an approximate 1.2 to 1.6-fold increase in plasma AUC of sitagliptin was observed in patients with mild renal impairment ($eGFR \geq 60$ mL/min/1.73 m² to <90 mL/min/1.73 m²) and patients with moderate renal

impairment (eGFR \geq 45 mL/min/1.73 m² to <60 mL/min/1.73 m²), respectively, which is not a clinically meaningful increase to require dosage adjustment.

An approximately 2-fold increase in the plasma AUC of sitagliptin was observed in patients with moderate renal impairment (eGFR \geq 30 mL/min/1.73 m² to <45 mL/min/1.73 m²) and an approximately 4-fold increase was observed in patients with severe renal impairment (eGFR <30 mL/min/1.73 m²) including patients with ESRD on hemodialysis, as compared to normal healthy control subjects.

To achieve plasma concentrations of sitagliptin similar to those in patients with normal renal function, lower dosages are recommended in patients with an eGFR <45 mL/min/1.73 m² including patients with severe renal impairment and patients with ESRD on hemodialysis (see [WARNINGS AND PRECAUTIONS](#), [DOSAGE AND ADMINISTRATION](#) and [CLINICAL TRIALS](#)).

STORAGE AND STABILITY

Store at room temperature (15°C to 30°C).

DOSAGE FORMS, COMPOSITION AND PACKAGING

Tablets JANUVIA[®], 25 mg, are pink, round, film-coated tablets with “221” on one side. They are supplied in bottles of 30.

Tablets JANUVIA[®], 50 mg, are light beige, round, film-coated tablets with “112” on one side. They are supplied in bottles of 30.

Tablets JANUVIA[®], 100 mg, are beige, round, film-coated tablets with “277” on one side. They are supplied in bottles of 30 and 100.

Each film-coated tablet of JANUVIA[®] contains 32.13, 64.25, or 128.5 mg of sitagliptin phosphate monohydrate, which is equivalent to 25, 50 or 100 mg, respectively, of free base.

Each film-coated tablet of JANUVIA[®] contains the following inactive ingredients: microcrystalline cellulose, anhydrous dibasic calcium phosphate (calcium hydrogen phosphate, anhydrous), croscarmellose sodium, magnesium stearate, and sodium stearyl fumarate. In addition, the film coating contains the following inactive ingredients: polyvinyl alcohol, polyethylene glycol (macrogol), talc, titanium dioxide, red iron oxide, and yellow iron oxide.

PART II: SCIENTIFIC INFORMATION

PHARMACEUTICAL INFORMATION

Drug Substance

Common name: sitagliptin phosphate monohydrate

Chemical name: 7-[(3*R*)-3-amino-1-oxo-4-(2,4,5-trifluorophenyl)butyl]-5,6,7,8-tetrahydro-3-(trifluoromethyl)-1,2,4-triazolo[4,3-*a*]pyrazine phosphate (1:1) monohydrate.

Molecular formula: $C_{16}H_{15}F_6N_5O \cdot H_3PO_4 \cdot H_2O$

Molecular mass: 523.32

Structural formula:

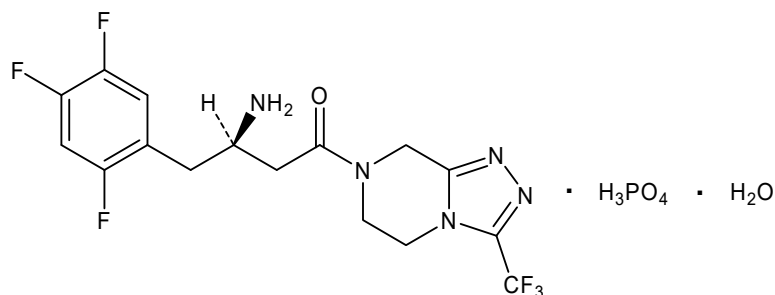

Physicochemical properties: Sitagliptin phosphate monohydrate is a white to off-white, crystalline, non-hygroscopic powder. It is soluble in water and N, N-dimethyl formamide; slightly soluble in methanol; very slightly soluble in ethanol, acetone, and acetonitrile; and insoluble in isopropanol and isopropyl acetate.

CLINICAL TRIALS

Study demographics and trial design

Table 10 – Summary of Patient Demographics for Clinical Trials in Specific Indication

Study #	Trial design	Dosage, route of administration and duration	Study subjects (n=number)	Mean age (Range)	Gender
Study 1 (P020)	Multicentre, randomized, double-blind, placebo-controlled	JANUVIA® 100 mg once daily + ≥1500 mg/day Metformin or Placebo + ≥1500 mg/day Metformin Oral 24-week	701	54.5 years (19–78)	Male: 400 Female: 301
Study 2 (P024)	Multicentre, randomized, double-blind, with an active comparator	JANUVIA® 100 mg/day + ≥1500 mg/day Metformin or Glipizide 5–20 mg/day + ≥1500 mg/day Metformin Oral 52-week	1172	Male 23–79 Female 22–78	Male: 694 Female: 478
Study 3 (P023)	Multicentre, randomized, double-blind, placebo-controlled	Placebo or 100 mg or 200 mg JANUVIA® once daily Oral 18-week	521	55.1 years (27–76)	Male: 283 Female: 238
Study 4 (P021)	Multicentre, randomized, double-blind, placebo-controlled	Placebo or 100 mg or 200 mg JANUVIA® once daily Oral 24-week	741	54.2 years (18–75)	Male: 383 Female: 358
Study 5 (P049)	Multicentre, randomized double-blind active-controlled	JANUVIA® 100 mg/day or Metformin 500 mg/day and titrated to 1500 to 2000 mg/day Oral 24 Weeks	1050	56.0 years (20–78)	Male: 484 Female: 566

Table 10 – Summary of Patient Demographics for Clinical Trials in Specific Indication

Study #	Trial design	Dosage, route of administration and duration	Study subjects (n=number)	Mean age (Range)	Gender
Study 6 (P035)	Multicentre, randomized, double-blind, placebo-controlled	JANUVIA® 100 mg/day + Glimepiride ≥4 mg/day in combination with Metformin ≥1500 mg/day or Placebo + Glimepiride ≥4 mg/day in combination with Metformin ≥1500 mg/day Oral 24-week	229	58.0 years (33–75)	Male: 120 Female: 109
Study 7 (P051)	Multicentre, randomized, double-blind placebo-controlled	JANUVIA® 100 mg/day + Stable dose insulin (alone or in combination with metformin ≥1500 mg/day) or Placebo + stable dose insulin (alone or in combination with metformin ≥1500 mg/day) 24-week	641	57.8 years (25–82)	Male: 326 Female: 315
Study 8 (P028)	Multicentre, randomized, double-blind, placebo- and active- controlled	JANUVIA® 25 or 50 mg/day or Placebo for 12 weeks followed by glipizide 2.5 to 20 mg/day for 42 weeks Oral 54 weeks	91	67.9 years (41–92)	Male: 47 Female: 44

Table 10 – Summary of Patient Demographics for Clinical Trials in Specific Indication

Study #	Trial design	Dosage, route of administration and duration	Study subjects (n=number)	Mean age (Range)	Gender
Study 9 (P063)	Multicentre, randomized, double-blind, active-controlled	JANUVIA® 25 or 50 mg/day or Glipizide 2.5 to 20 mg/day Oral 54 weeks	423	64.2 years (33–89)	Male: 253 Female: 170
Study 10 (P073)	Multicentre, randomized, double-blind, active-controlled	JANUVIA® 25 mg/day or Glipizide 2.5 to 20 mg/day Oral 54 weeks	129	59.5 years (38–83)	Male: 77 Female: 52
Study 11 (P019)	Multicentre, randomized, double-blind, placebo-controlled	JANUVIA® 100 mg/day + 30 or 45 mg/day Pioglitazone or Placebo + 30 or 45 mg/day Pioglitazone Oral 24-week	353	56.2 years (24–87)	Male: 196 Female: 157
Study 12 (P128)	Multicentre, randomized, double-blind, placebo-controlled	JANUVIA® 100 mg/day + Pioglitazone ≥30 mg/day + Metformin ≥1500 mg/day or Placebo + Pioglitazone ≥30 mg/day + Metformin ≥1500 mg/day Oral 26-week	313	56.1 (22–78)	Male: 195 Female: 118

Study results

Monotherapy

Placebo-Controlled Study: A total of 1262 patients with type 2 diabetes participated in two double-blind, placebo-controlled studies, one of 18-week and another of 24-week duration, to evaluate the efficacy and safety of JANUVIA[®] monotherapy. Patients with inadequate glycaemic control (HbA_{1c} 7% to 10%) were randomized to receive a 100 mg or 200 mg dose of JANUVIA[®] or placebo once daily.

Treatment with JANUVIA[®] at 100 mg daily provided significant improvements in HbA_{1c}, FPG, and 2-hour PPG compared to placebo (Table 11). The improvement in HbA_{1c} compared to placebo was not affected by gender, age, race, prior antihyperglycemic therapy or baseline BMI. Patients with a shorter length of time since diagnosis of diabetes (<3 years) or with higher baseline HbA_{1c} had greater reductions in HbA_{1c}. Overall, the 200 mg daily dose did not provide greater glycaemic efficacy than the 100 mg daily dose. The effect of JANUVIA[®] on lipid endpoints was similar to placebo. Body weight did not increase from the baseline with JANUVIA[®] (mean weight loss of 0.6 kg in the 18-week study and 0.2 kg in the 24-week study). Patients on placebo lost more weight (mean weight loss 0.7 kg in the 18-week study and 1.1 kg in the 24-week study) than patients on JANUVIA[®].

Table 11 – Glycaemic Parameters in 18- and 24-Week Placebo-Controlled Studies of JANUVIA[®] in Patients with Type 2 Diabetes[†]

	18-Week Study		24-Week Study	
	JANUVIA [®] 100 mg	Placebo	JANUVIA [®] 100 mg	Placebo
HbA_{1c} (%)	N=193	N=103	N=229	N=244
Baseline (mean)	8.0	8.1	8.0	8.0
Change from Baseline (adjusted mean [‡])	-0.5	0.1	-0.6	0.2
Difference from Placebo (adjusted mean [‡])	-0.6 [§]		-0.8 [§]	
Patients (%) achieving HbA _{1c} <7%	69 [§] (35.8%)	16 (15.5%)	93 [§] (40.6%)	41 (16.8%)
FPG (mmol/L)	N=201	N=107	N=234	N=247
Baseline (mean)	10.0	10.2	9.5	9.8
Change from baseline (adjusted mean [‡])	-0.7	0.4	-0.7	0.3
Difference from Placebo (adjusted mean [‡])	-1.1 [§]		-1.0 [§]	
2-hour PPG (mmol/L)	NA	NA	N=201	N=204
Baseline (mean)			14.3	15.0
Change from baseline (adjusted mean [‡])			-2.7	-0.1
Difference from Placebo (adjusted mean [‡])			-2.6 [§]	

[†] All Patients Treated Population (an intention-to-treat analysis).

[‡] Least squares means adjusted for prior antihyperglycemic therapy status and baseline value.

[§] p<0.001 compared to placebo.

^{NA} Data not available.

Active-Controlled Study with Metformin: The efficacy of JANUVIA[®] compared to that of metformin was evaluated in a 24-week, double-blind, metformin-controlled trial in patients with type 2 diabetes and inadequate glycemic control on diet and exercise and who were not on antihyperglycemic therapy (off therapy for at least 4 months). In this study, patients with an HbA_{1c} of 6.5% to 9.0% were randomized to receive either JANUVIA[®] 100 mg daily (N=528) or metformin (N=522) for 24 weeks. Patients receiving metformin were given an initial dosage of 500 mg/day and then titrated to a dose of 1500 to 2000 mg/day over a period of up to 5 weeks based on tolerability. The mean dose of metformin after the titration period was approximately 1900 mg/day. Glycemic endpoints measured included HbA_{1c} and fasting glucose.

Both treatments resulted in a statistically significant improvement in glycemic control from baseline. At 24 weeks, the reduction from baseline in HbA_{1c} was -0.43% for JANUVIA[®] 100 mg daily and -0.57% for metformin in the per protocol population analysis.

The reduction in FPG was -0.64 mmol/L for JANUVIA[®] and -1.08 mmol/L for metformin. Body weight decreased from baseline in both treatment groups (JANUVIA[®]: -0.6 kg; metformin: -1.9 kg).

Sitagliptin in Combination with Metformin

Placebo-Controlled Study: A total of 701 patients with type 2 diabetes participated in a 24-week, randomized, double-blind, placebo-controlled study designed to assess the efficacy of JANUVIA[®] in combination with metformin. All patients were started on metformin monotherapy and the dose increased to at least 1500 mg per day. Patients were randomized to the addition of either 100 mg of JANUVIA[®] or placebo, administered once daily. Patients with congestive heart failure requiring pharmacological treatment were excluded from this study.

Glycemic parameters and body weight at final visit (24-week study) for JANUVIA[®] in combination with metformin are shown in Table 12.

Table 12 – Glycemic Parameters and Body Weight at Final Visit (24-week study) for JANUVIA® in Combination with Metformin[†]

	JANUVIA® 100 mg + Metformin	Placebo + Metformin
HbA_{1c} (%)	N=453	N=224
Baseline (mean)	8.0	8.0
Change from baseline (adjusted mean [‡])	-0.7	-0.0
Difference from placebo + metformin (adjusted mean [‡])	-0.7 [§]	
Patients (%) achieving HbA _{1c} <7%	213 (47.0%)	41 (18.3%)
FPG (mmol/L)	N=454	N=226
Baseline (mean)	9.4	9.6
Change from baseline (adjusted mean [‡])	-0.9	0.5
Difference from placebo + metformin (adjusted mean [‡])	-1.4 [§]	
2-hour PPG (mmol/L)	N=387	N=182
Baseline (mean)	15.3	15.1
Change from baseline (adjusted mean [‡])	-3.4	-0.6
Difference from placebo + metformin (adjusted mean [‡])	-2.8 [§]	
Body Weight (kg)[*]	N=399	N=169
Baseline (mean)	86.9	87.6
Change from baseline (adjusted mean [‡])	-0.7	-0.6
Difference from placebo + metformin (adjusted mean [‡])	-0.1 [¶]	

[†] All Patients Treated Population (an intention-to-treat analysis).

[‡] Least squares means adjusted for prior antihyperglycemic therapy and baseline value.

[§] p<0.001 compared to placebo + metformin.

^{*} All Patients as Treated (APaT) population, excluding patients given glycemic rescue therapy.

[¶] Not statistically significant (p≥0.05) compared to placebo + metformin.

Active-Controlled (Sulfonylurea Agent) Study: Long-term maintenance of effect was evaluated in a 52-week, double-blind, glipizide-controlled trial in patients with type 2 diabetes and inadequate glycemic control on metformin monotherapy at ≥ 1500 mg/day. In this study, patients were randomized to the addition of either JANUVIA[®] 100 mg daily (N=588) or glipizide (N=584) for 52 weeks. Patients receiving glipizide were given an initial dosage of 5 mg/day and then electively titrated by the investigator to a target FPG of 6.1 mmol/L, without significant hypoglycemia, over the next 18 weeks. A maximum dosage of 20 mg/day was allowed to optimize glycemic control. Thereafter, the glipizide dose was to have been kept constant. The mean daily dose of glipizide after the titration period was 10.3 mg.

Both treatments resulted in a statistically significant improvement in glycemic control from baseline. After 52 weeks, the reduction from baseline in HbA_{1c} was 0.67% for JANUVIA[®] 100 mg daily and 0.67% for glipizide, confirming the non-inferiority of JANUVIA[®] compared to glipizide. The reduction in FPG was 0.6 mmol/L for JANUVIA[®] and 0.4 mmol/L for glipizide. In this study, the proinsulin to insulin ratio, a marker of efficiency of insulin synthesis and release, improved with JANUVIA[®] relative to glipizide. The incidence of hypoglycemia in the JANUVIA[®] group (4.9%) was significantly lower than that in the glipizide group (32.0%). Patients treated with JANUVIA[®] exhibited a significant mean decrease from baseline in body weight compared to a significant weight gain in patients administered glipizide (-1.5 kg vs. +1.1 kg).

Sitagliptin Add-on Combination Therapy

Add-on Combination Therapy with Metformin plus Glimepiride: In a 24-week, randomized, double-blind, placebo-controlled study designed to assess the efficacy of sitagliptin 100 mg once daily (N=116) compared to placebo (N=113), 229 patients were on the combination of glimepiride (≥ 4 mg per day) and metformin (≥ 1500 mg per day); the results of the glycemic endpoints, including HbA_{1c} and FPG, are described below.

The combination of sitagliptin, glimepiride, and metformin provided significant reduction from baseline in HbA_{1c} and FPG compared to placebo (see Table 13). Mean reductions from baseline in HbA_{1c} compared with placebo were generally greater for patients with higher baseline HbA_{1c} values. Patients treated with sitagliptin, had a modest increase in body weight (0.4 kg) compared to those given placebo who had a significant decrease in body weight (-0.7 kg).

Table 13 – Glycemic Parameters and Body Weight at Final Visit (24-Week Study) for JANUVIA[®] in Add-on Combination Therapy with Metformin plus Glimepiride[†]

	JANUVIA[®] 100 mg + Metformin + Glimepiride	Placebo + Metformin + Glimepiride
HbA_{1c} (%)	N=115	N=105
Baseline (mean)	8.27	8.28
Change from baseline (adjusted mean [‡])	-0.59	0.30
Difference from placebo (adjusted mean [‡])	-0.89 [§]	
Patients (%) achieving HbA _{1c} <7%	26 (22.6)	1 (1.0)
FPG (mmol/L)	N=115	N=109
Baseline (mean)	9.95	9.93
Change from baseline (adjusted mean [‡])	-0.43	0.72
Difference from placebo (adjusted mean [‡])	-1.15 [§]	
Body Weight (kg)[*]	N=102	N=74
Baseline (mean)	86.5	84.6
Change from baseline (adjusted mean [‡])	0.4	-0.7
Difference from placebo (adjusted mean [‡])	1.1 ^{††}	

[†] All Patients Treated Population (an intention-to-treat analysis).

[‡] Least squares means adjusted for prior antihyperglycemic therapy status and baseline value.

[§] p<0.001 compared to placebo.

^{*} All Patients as Treated (APaT) population, excluding patients given glycemic rescue therapy.

^{††} p=0.007 compared to placebo.

Add-on Combination Therapy with Insulin (with or without Metformin): A total of 641 patients with type 2 diabetes participated in a 24-week, randomized, double-blind, placebo-controlled study designed to assess the efficacy of JANUVIA[®] as add-on combination therapy with a stable dose of insulin (with or without metformin). Patients with an HbA_{1c} of 7.5% to 11.0% while on a stable regimen of pre-mixed, long-acting, or intermediate-acting insulin with or without metformin (≥1500 mg per day) were randomized to the addition of either 100 mg of JANUVIA[®] or placebo, administered once daily. Patients using pre-meal short-acting or rapid-acting insulins that were not components of a pre-mixed insulin formulation, or that were administered via insulin pumps, were not included in this study. Glycemic endpoints measured included HbA_{1c}, fasting glucose, and 2-hour post-prandial glucose.

In combination with insulin (including patients taking and not taking metformin), JANUVIA[®] provided significant improvements in HbA_{1c}, FPG, and 2-hour PPG compared to placebo (Table 14). There was no significant difference between JANUVIA[®] and placebo in body weight change.

Table 14 – Glycemic Parameters and Body Weight at Final Visit (24-Week Study) for JANUVIA® as Add-on Combination Therapy with a Stable Dose of Insulin (with or without Metformin[†])

	JANUVIA® 100 mg + Insulin (+/- Metformin)	Placebo + Insulin (+/- Metformin)
HbA_{1c} (%)	N=305	N=312
Baseline (mean)	8.7	8.6
Change from baseline (adjusted mean [‡])	-0.6	-0.0
Difference from placebo (adjusted mean ^{‡,§})	-0.6*	
Patients (%) achieving HbA _{1c} <7%	39 (12.8)	16 (5.1)
FPG (mmol/L)	N=310	N=313
Baseline (mean)	9.7	9.8
Change from baseline (adjusted mean [‡])	-1.0	-0.2
Difference from placebo (adjusted mean [‡])	-0.8	
2-hour PPG (mmol/L)	N=240	N=257
Baseline (mean)	16.0	16.1
Change from baseline (adjusted mean [‡])	-1.7	0.3
Difference from placebo (adjusted mean [‡])	-2.0*	
Body Weight (kg)[¶]	N=266	N=266
Baseline (mean)	86.6	87.4
Change from baseline (adjusted mean [‡])	0.1	0.1
Difference from placebo (adjusted mean [‡])	0.0 [#]	

[†] All Patients Treated Population (an intention-to-treat analysis).

[‡] Least squares means adjusted for metformin use at Visit 1 (yes/no), insulin use at Visit 1 (pre-mixed vs. non-pre-mixed [intermediate- or long-acting]), and baseline value.

[§] Treatment by stratum interaction was not significant (p>0.10) for metformin stratum and for insulin stratum.

* p<0.001 compared to placebo.

[¶] All Patients as Treated (APaT) population, excluding data following glycemic rescue therapy.

[#] Not statistically significant (p≥0.05) compared to placebo.

Table 15 – Glycemic Parameters at Final Visit (24-Week Study) for JANUVIA® as Add-on Combination Therapy with a Stable Dose of Insulin (with or without Metformin[†])

	JANUVIA® 100 mg + Insulin	Placebo + Insulin	JANUVIA® 100 mg + Insulin + Metformin	Placebo + Insulin + Metformin
HbA_{1c} (%)	N=82	N=83	N=223	N=229
Baseline (mean)	8.7	8.8	8.7	8.6
Change from baseline (adjusted mean [‡])	-0.6	0.1	-0.7	-0.1
Difference from placebo (adjusted mean [‡])	-0.7*		-0.5*	
Patients (%) achieving HbA _{1c} <7%	7 (8.5)	4 (4.8)	32 (14.3)	12 (5.2)
FPG (mmol/L)	N=85	N=84	N=225	N=229
Baseline (mean)	10.1	10.5	9.6	9.8
Change from baseline (adjusted mean [‡])	-0.7	-0.3	-1.2	-0.2
Difference from placebo (adjusted mean [‡])	-0.3 [§]		-1.0*	
2-hour PPG (mmol/L)	N=58	N=68	N=182	N=189
Baseline (mean)	17.9	18.0	15.6	15.6
Change from baseline (adjusted mean [‡])	-1.0	0.3	-2.2	0.1
Difference from placebo (adjusted mean [‡])	-1.3 [#]		-2.2*	

[†] All Patients Treated Population (an intention-to-treat analysis).

[‡] Least squares means adjusted for insulin use at Visit 1 (pre-mixed vs. non-pre-mixed [intermediate- or long-acting]), and baseline value.

* p<0.001 compared to placebo.

[§] Not statistically significant (p≥0.05) compared to placebo.

[#] p=0.037 compared to placebo.

Add-on Combination Therapy with Pioglitazone: A total of 353 patients with type 2 diabetes participated in a 24-week, randomized, double-blind, placebo-controlled study designed to assess the efficacy of JANUVIA® in combination with pioglitazone. All patients were on pioglitazone monotherapy at a dose of 30-45 mg per day. Patients were randomized to the addition of either 100 mg of JANUVIA® or placebo, administered once daily. Glycemic endpoints measured included HbA_{1c} and fasting glucose.

In combination with pioglitazone, JANUVIA® provided significant improvements in HbA_{1c} and FPG compared to placebo with pioglitazone (Table 16). The improvement in HbA_{1c} was not affected by baseline HbA_{1c}, prior anti-hyperglycemic therapy, gender, age, race, baseline BMI, length of time since diagnosis of diabetes, presence of metabolic syndrome (according to NCEP criteria), or standard indices of insulin resistance (HOMA-IR) or insulin secretion (HOMA-β). Treatment with JANUVIA® did not significantly increase body weight from baseline compared to placebo.

Table 16 – Glycemic Parameters and Body Weight at Final Visit (24-week study) for JANUVIA® in Combination with Pioglitazone†

	JANUVIA® 100 mg + Pioglitazone	Placebo + Pioglitazone
HbA_{1c} (%)	N=163	N=174
Baseline (mean)	8.1	8.0
Change from baseline (adjusted mean‡)	-0.9	-0.2
Difference from pioglitazone alone (adjusted mean‡)	-0.7§	
Patients (%) achieving HbA _{1c} <7%	74 (45.4%)	40 (23.0%)
FPG (mmol/L)	N=163	N=174
Baseline (mean)	9.3	9.2
Change from baseline (adjusted mean‡)	-0.9	0.1
Difference from pioglitazone alone (adjusted mean‡)	-1.0§	
Body Weight (kg)*	N=133	N=136
Baseline (mean)	90.0	85.6
Change from baseline (adjusted mean‡)	1.8	1.5
Difference from pioglitazone alone (adjusted mean‡)	0.2¶	

† All Patients Treated Population (an intention-to-treat analysis).

‡ Least squares means adjusted for prior antihyperglycemic therapy status and baseline value.

§ p<0.001 compared to placebo + pioglitazone.

* All Patients as Treated (APaT) population, excluding patients given glycemic rescue therapy.

¶ Not statistically significant (p≥0.05) compared to placebo + pioglitazone.

Add-on Combination Therapy with Pioglitazone and Metformin: A total of 313 patients with type 2 diabetes participated in a 26-week, randomized, double-blind, placebo-controlled study designed to assess the efficacy of sitagliptin in combination with pioglitazone and metformin. Patients with inadequate glycemic control on a stable regimen of pioglitazone (30 or 45 mg per day) and metformin (≥1500 mg per day) were randomized to the addition of either 100 mg of sitagliptin or placebo, administered once daily.

In combination with pioglitazone and metformin, sitagliptin provided significant improvements in HbA_{1c}, FPG, and 2-hour PPG compared to placebo with pioglitazone and metformin (Table 17). Lipid effects were generally neutral. The difference between sitagliptin and placebo in body weight change was not significant.

Table 17 – Glycemic Parameters and Body Weight at Final Visit (26-Week Study) for JANUVIA® as Add-on Combination Therapy with Pioglitazone and Metformin†

	Sitagliptin 100 mg + Pioglitazone 30 or 45 mg + Metformin	Placebo + Pioglitazone 30 or 45 mg + Metformin
HbA_{1c} (%)	N=152	N=153
Baseline (mean)	8.8	8.6
Change from baseline (adjusted mean‡)	-1.2	-0.4
Difference from placebo (adjusted mean‡)	-0.7§	
Patients (%) achieving HbA _{1c} <7%	38 (25.0)	15 (9.8)
FPG (mmol/L)	N=155	N=153
Baseline (mean)	10.0	9.6
Change from baseline (adjusted mean‡)	-1.1	-0.2
Difference from placebo (adjusted mean‡)	-1.0§	
2-hour PPG (mmol/L)	N=141	N=135
Baseline (mean)	15.3	14.7
Change from baseline (adjusted mean‡)	-3.0	-0.8
Difference from placebo (adjusted mean‡)	-2.2§	
Body Weight (kg)*	N=146	N=128
Baseline (mean)	81.4	82.0
Change from baseline (adjusted mean‡)	1.3	1.1
Difference from placebo (adjusted mean‡)	0.1¶	

† Full Analysis Set population (an intention-to-treat analysis).

‡ Least squares mean adjusted for baseline value.

§ p<0.001 compared to placebo.

* All Patients as Treated (APaT) population, excluding data following glycemic rescue therapy.

¶ Not statistically significant (p≥0.05) compared to placebo.

Study in Special Population

Patients with Renal Impairment: A study comparing sitagliptin at 25 or 50 mg once daily to glipizide at 2.5 to 20 mg/day was conducted in patients with moderate to severe renal impairment. In this study, 277 patients with chronic renal impairment were included in the Per-protocol population (135 patients on JANUVIA®: moderate [n=98], severe [n=37]; and 142 patients on glipizide: moderate [n=106], severe [n=36]). After 54 weeks, the mean reduction from baseline in HbA_{1c} was -0.76% with sitagliptin and -0.64% with glipizide (Per-Protocol Analysis). In this study, the efficacy and safety profile of sitagliptin at 25 or 50 mg once daily was generally similar to that observed in other monotherapy studies in patients with normal renal function. The incidence of hypoglycemia in the sitagliptin group (6.2%) was significantly lower than that in the glipizide group (17.0%).

Another study comparing sitagliptin at 25 mg once daily to glipizide at 2.5 to 20 mg/day was conducted in 129 patients with ESRD who were on dialysis (64 patients on JANUVIA®; and 65 patients on glipizide). After 54 weeks, the mean reduction from baseline in HbA_{1c} was -0.72% with sitagliptin and -0.87% with glipizide. In this study, the efficacy and safety profile of sitagliptin at 25 mg once daily was generally similar to that observed in other monotherapy studies in patients with normal renal function. The incidence of hypoglycemia was not significantly different between the treatment groups (sitagliptin: 6.3%; glipizide: 10.8%).

In a study involving 91 patients with type 2 diabetes and chronic renal impairment (creatinine clearance <50 mL/min), the safety and tolerability of treatment with sitagliptin at 25 or 50 mg once daily were generally similar to placebo.

TECOS Cardiovascular Safety Study: The Trial Evaluating Cardiovascular Outcomes with Sitagliptin (TECOS) was a randomized double-blind, placebo-controlled, parallel-group, event-driven, multicentre study in patients with type 2 diabetes mellitus (HbA1c ≥ 6.5 to 8.0%) and established vascular disease (coronary artery disease, ischemic cerebrovascular disease, atherosclerotic peripheral artery disease). The study included 14,671 (70.7% male, 29.3% female) patients in the intention-to-treat population who received JANUVIA[®] (N=7,332) 100 mg daily (or 50 mg daily if the baseline eGFR was ≥ 30 and <50 mL/min/1.73 m²) or placebo (N=7,339) added to usual care targeting regional standards for HbA1c and CV risk factors. The median duration of treatment was 31 months and the median duration of follow-up was 36 months. Patients with an eGFR <30 mL/min/1.73 m² were not to be enrolled in the study. The study population included 10,863 patients with coronary artery disease, 3,588 patients with cerebrovascular disease, 2,433 patients with peripheral artery disease, 2,643 patients with prior congestive heart failure (including 373 with New York Heart Association [NYHA] class 3 or higher), 2,004 patients ≥ 75 years of age, and 3,324 patients with renal impairment (eGFR <60 mL/min/1.73 m²).

The primary cardiovascular endpoint was a composite of the first occurrence of cardiovascular death, non-fatal myocardial infarction, non-fatal stroke, or hospitalization for unstable angina. Secondary cardiovascular endpoints included a composite of the first occurrence of cardiovascular death, non-fatal myocardial infarction, or non-fatal stroke; as well as first occurrence of the following independent CV endpoints: cardiovascular death, myocardial infarction (fatal + non-fatal), stroke (fatal + non-fatal), hospitalization for unstable angina, hospitalization for heart failure, and all-cause mortality. A composite endpoint of first occurrence of death due to heart failure or hospitalization for congestive heart failure was also assessed

JANUVIA[®], when added to usual care, did not increase the risk of major adverse cardiovascular events or the risk of death or hospitalization for heart failure compared to usual care without JANUVIA[®] in patients with type 2 diabetes. Superiority to placebo was not demonstrated for any endpoint (Table 18).

Table 18 -Rates of Composite Cardiovascular Outcomes and Key Secondary Outcomes Censored at the End of Follow-up (Intention-to-Treat Population)

	JANUVIA [®] (N=7,332)		Placebo (N=7,339)		Hazard Ratio (95% CI)	p-value [†]
	Subjects with Events N (%)	Incidence Rate per 100 Patient-Years*	Subjects with Events N (%)	Incidence Rate per 100 Patient-Years*		
Primary Composite Endpoint (Cardiovascular death, non-fatal myocardial infarction, non-fatal stroke, or hospitalization for unstable angina)	839 (11.4)	4.1	851 (11.6)	4.2	0.98 (0.89, 1.08)	<0.001
Secondary Composite Endpoint (Cardiovascular death, non-fatal myocardial infarction, or non-fatal stroke)	745 (10.2)	3.6	746 (10.2)	3.6	0.99 (0.89, 1.10)	<0.001
Secondary Outcome						
Cardiovascular death	380 (5.2)	1.7	366 (5.0)	1.7	1.03 (0.89, 1.19)	0.711
All myocardial infarction (fatal and non-fatal)	300 (4.1)	1.4	316 (4.3)	1.5	0.95 (0.81, 1.11)	0.487
All stroke (fatal and non-fatal)	178 (2.4)	0.8	183 (2.5)	0.9	0.97 (0.79, 1.19)	0.760
Hospitalization for unstable angina	116 (1.6)	0.5	129 (1.8)	0.6	0.90 (0.70, 1.16)	0.419
Death from any cause	547 (7.5)	2.5	537 (7.3)	2.5	1.01 (0.90, 1.14)	0.875
Hospitalization for heart failure [‡]	228 (3.1)	1.1	229 (3.1)	1.1	1.00 (0.83, 1.20)	0.983
Death due to heart failure or hospitalization for heart failure [‡]	237 (3.2)	1.1	240 (3.3)	1.1	0.99 (0.83, 1.18)	0.909

* Incidence rate per 100 patient-years is calculated as $100 \times$ (total number of patients with ≥ 1 event during eligible exposure period per total patient-years of follow-up).

[†] Based on a Cox model stratified by region. For composite endpoints, the p-values correspond to a test of non-inferiority seeking to show that the hazard ratio is less than 1.3. For all other endpoints, the p-values correspond to a test of differences in hazard rates.

[‡] The analysis of hospitalization for heart failure was adjusted for a history of heart failure at baseline.

DETAILED PHARMACOLOGY

Sitagliptin was assessed for its ability to improve glucose tolerance in lean and diet-induced obese (DIO) mice following dextrose challenge and in diabetic (db/db) mice. In lean and DIO mice, single oral doses of sitagliptin reduced blood glucose levels in a dosage-dependent manner. Acute lowering of blood glucose was also demonstrated in diabetic db/db mice. A 2- to 3-fold increase in active GLP-1 was seen at the maximally effective dose of 1 mg/kg sitagliptin in lean mice. These results are consistent with the action of sitagliptin as an anti-hyperglycemic agent.

Treatment with GLP-1 or with DPP-4 inhibitors in animal models of type 2 diabetes has been demonstrated to improve beta cell responsiveness to glucose, stimulate insulin biosynthesis and release, increase beta cell neogenesis, and decrease beta cell death. The effects on beta cell neogenesis and beta cell death have not been studied in humans.

TOXICOLOGY

Acute Toxicity

The approximate LD50 of sitagliptin given orally to rats is >3000 mg/kg (maximum dose tested). This dose is equivalent to ≥ 200 times the human exposure based on the recommended daily adult human dose of 100 mg/day. In mice the approximate oral LD50 of sitagliptin is 4000 mg/kg. This dose is equivalent to >385 times the human exposure based on recommended daily adult human dose of 100 mg/day.

Chronic Toxicity

The toxicity potential of sitagliptin was evaluated in a series of repeated dose toxicity studies of up to 53 weeks in dogs and up to 27 weeks in rats. In dogs administered sitagliptin orally at dosages of 2, 10 and 50 mg/kg/day, the no-observed effect level was 10 mg/kg/day (up to 6 times the human exposure based on the recommended daily adult human dose of 100 mg/day). Treatment-related physical signs observed in the 50 mg/kg/day group included open-mouth breathing, salivation, white foamy emesis, ataxia, trembling, decreased activity, and/or hunched posture. These signs were transient, slight in degree, and occurred with decreased incidence during the course of the study. In addition, very slight to slight skeletal muscle degeneration was observed histologically in the 14- and 27-week toxicity studies at the 50 mg/kg/day dose. However, no skeletal muscle degeneration was found in the 53-week toxicity study, indicating the lack of reproducibility or progression of this change with increased duration of treatment. The 50 mg/kg/day dose in dogs resulted in systemic exposure values 26 times the human exposure at the recommended daily adult human dose of 100 mg/day. In rats, sitagliptin administered orally at dosages of up to 180 mg/kg/day (up to 23 times the human exposure based on the recommended daily adult human dose of 100 mg/day), no significant toxicity was observed. The only drug-related effect observed was post-dose salivation, likely related to poor palatability of the drug, at doses of 60 mg/kg/day and 180 mg/kg/day.

The treatment-related changes noted in animals do not suggest any clinical concerns at the recommended therapeutic dosages in humans.

Carcinogenicity

A two-year carcinogenicity study was conducted in male and female rats given oral doses of sitagliptin of 50, 150, and 500 mg/kg/day. There was an increased incidence of hepatic adenomas and carcinomas in the high-dose males and hepatic carcinomas in the high-dose females. This dose in rats results in approximately 58 times the human exposure based on the recommended daily adult human dose of 100 mg/day. This dose level was associated with hepatotoxicity in rats. The no-observed effect level for induction of hepatic neoplasia was 150 mg/kg/day, approximately 19-fold the human exposure at the 100-mg recommended dose. Since hepatotoxicity has been shown to correlate with induction of hepatic neoplasia in rats, this increased incidence of hepatic tumors in rats was likely

secondary to chronic hepatic toxicity at this high dose. The clinical significance of these findings for humans is unknown.

A two-year carcinogenicity study was conducted in male and female mice at oral doses of 50, 125, 250, and 500 mg/kg/day. Sitagliptin did not increase tumor incidence in mice in any organ at doses up to 500 mg/kg/day (approximately 68 times the human exposure based on the recommended daily adult human dose of 100 mg/day).

Mutagenesis

Sitagliptin was not mutagenic or clastogenic in a battery of genetic toxicology studies, including the Ames bacterial assay (microbial mutagenesis test), Chinese hamster ovary cells (CHO cells) chromosome aberration assay, an *in vitro* cytogenetics assay using CHO cells, an *in vitro* rat hepatocyte DNA alkaline elution assay (an assay which measures the compound's ability to induce single strand breaks in DNA), and an *in vivo* micronucleus assay.

Reproduction

No adverse effects upon fertility were observed in male and female rats given sitagliptin orally at doses up to 1000 mg/kg daily (up to approximately 100 times the human exposure based on the recommended daily adult human dose of 100 mg/day) prior to and throughout mating.

Development

Sitagliptin was not teratogenic in rats at oral doses up to 250 mg/kg or in rabbits given up to 125 mg/kg during organogenesis (up to 32 and 22 times the human exposure based on the recommended daily adult human dose of 100 mg/day). A slight, treatment-related increased incidence of fetal rib malformations (absent, hypoplastic and wavy ribs) was observed in the offspring of rats at oral doses of 1000 mg/kg/day (approximately 100 times the human exposure based on the recommended daily adult human dose of 100 mg/day). The no-observed effect level for developmental effects was 250 mg/kg/day (32 times the human exposure based on the recommended daily adult human dose of 100 mg/day). Treatment-related decreases in the mean preweaning body weight of both sexes and postweaning body weight gain of male animals was observed in offspring of rats at oral doses of 1000 mg/kg.

REFERENCES

1. Canadian Diabetes Association Clinical Practice Guidelines Expert Committee. Canadian Diabetes Association 2013 Clinical Practice Guidelines for the Prevention and Management of Diabetes in Canada. *Can J Diabetes* 2013;37 (Suppl 1):S1-S212.
2. Charbonnel B, Karasik A, Liu J, Wu M, Meininger G. Efficacy and safety of the dipeptidyl peptidase-4 inhibitor sitagliptin added to ongoing metformin therapy in patients with type 2 diabetes inadequately controlled with metformin alone. *Diabetes Care* 2006;29(12):2638-43.
3. Drucker DJ. Development of glucagon-like peptide-1-based pharmaceuticals as therapeutic agents for the treatment of diabetes. *Curr Pharm Des* 2001;7(14):1399-412.
4. Nauck MA, Meininger G, Sheng D, Terranella L, Stein PP. Efficacy and safety of the dipeptidyl peptidase-4 inhibitor, sitagliptin, compared with the sulfonylurea, glipizide, in patients with type 2 diabetes inadequately controlled on metformin alone: a randomized, double-blind, non-inferiority trial. *Diabetes Obes Metab* 2007;9(2):194-205.
5. Williams-Herman D, Engel SS, Round E, Johnson J, Golm GT et al. Safety and tolerability of sitagliptin in clinical studies: a pooled analysis of data from 10,246 patients with type 2 diabetes. *BMC Endocr Disord* 2010;10(7).
6. Vilsbøll T, Rosenstock J, Yki-Järvinen H, Cefalu WT, Chen Y, Luo E et al. Efficacy and safety of sitagliptin when added to insulin therapy in patients with type 2 diabetes. *Diabetes Obes Metab* 2010;12:167-77.
7. Rosenstock J, Brazg R, Andryuk J. P, Lu K, Stein P. Efficacy and Safety of the Dipeptidyl Peptidase-4 inhibitor Sitagliptin Added to Ongoing Pioglitazone Therapy in Patients with Type 2 Diabetes: A 24-Week, Multicenter, Randomized, Double-Blind, Placebo-Controlled, Parallel-Group Study. *Clinical Therapeutics* 2006;28:1556-1568.
8. Green JB, Bethel MA, Armstrong PW, Buse JB et al. Effect of sitagliptin on cardiovascular outcomes in type 2 diabetes. *N Engl J Med* 2015;373: 232-42.

PART III: CONSUMER INFORMATION

 **JANUVIA[®]**
sitagliptin tablets
(as sitagliptin phosphate monohydrate)

This leaflet is Part III of a three-part “Product Monograph” published when JANUVIA[®] was approved for sale in Canada and is designed specifically for Consumers. This leaflet is a summary and will not tell you everything about JANUVIA[®]. Contact your physician or pharmacist if you have any questions about the drug.

Please read this information carefully before you start to take your medicine, even if you have just refilled your prescription. Some of the information may have changed.

Remember that your physician has prescribed this medicine only for you. Never give it to anyone else.

ABOUT THIS MEDICATION

What the medication is used for:

- JANUVIA[®] can be used to improve blood sugar levels in adult patients with type 2 diabetes mellitus in addition to diet and exercise:
 - alone in patients who cannot take metformin
 - in combination with metformin
 - in combination with metformin and a sulfonylurea (e.g. glyburide, gliclazide or glimepiride)
 - in combination with premixed or long/intermediate acting insulin (with or without metformin)
 - in combination with pioglitazone (with or without metformin)

What it does:

JANUVIA[®] is a member of a class of medicines called DPP-4 inhibitors (dipeptidyl peptidase-4 inhibitors). JANUVIA[®] helps to improve the levels of insulin when blood sugar level is high, especially after a meal. JANUVIA[®] also helps to decrease the amount of sugar made by the body. JANUVIA[®] is unlikely to cause low blood sugar (**hypoglycemia**).

What is type 2 diabetes?

Type 2 diabetes is a condition in which your body does not make enough insulin, and/or does not use the insulin that your body produces as well as it should. When this happens, sugar (glucose) builds up in the blood. This can lead to serious problems.

When it should not be used:

Do not take JANUVIA[®] if you are allergic to any of the ingredients in JANUVIA[®].

What the medicinal ingredient is:
sitagliptin phosphate monohydrate

What the non-medicinal ingredients are:
Each film-coated tablet of JANUVIA[®] contains the following inactive ingredients: microcrystalline cellulose, anhydrous dibasic calcium phosphate (calcium hydrogen phosphate, anhydrous), croscarmellose sodium, magnesium stearate, and sodium stearyl fumarate. In addition, the film coating contains the following inactive ingredients: polyvinyl alcohol, polyethylene glycol, talc, titanium dioxide, red iron oxide, and yellow iron oxide.

What dosage forms it comes in:

Tablets: Each tablet contains 25, 50 or 100 mg sitagliptin.

WARNINGS AND PRECAUTIONS

BEFORE you use JANUVIA[®] talk to your physician or pharmacist if:

- you have or have had pancreatitis (inflammation of the pancreas);
- you have risk factors for pancreatitis such as:
 - gallstones (solid particles that form in the gall bladder),
 - a history of alcoholism,
 - high triglyceride levels;
- you have type 1 diabetes;
- you have or have had diabetic ketoacidosis (increased ketones in the blood or urine);
- you are taking a sulfonylurea. When JANUVIA[®] is used in combination with a sulfonylurea and metformin, or in combination with insulin (with or without metformin), low blood sugar can occur. Your physician may consider lowering the dose of the sulfonylurea or insulin. Take precautions to avoid low blood sugar while driving or using machinery.
- you have or have had an allergic reaction to JANUVIA[®];
- you have or have had kidney problems;
- you have liver problems;
- you had an organ transplant;
- you have human immunodeficiency syndrome (HIV);
- you are pregnant or plan to become pregnant; JANUVIA[®] is not recommended for use during pregnancy;
- you are breast-feeding or plan to breast-feed. It is not known if JANUVIA[®] passes into breast milk.

JANUVIA[®] is not recommended for use in patients under 18 years of age.

JANUVIA[®] may cause abnormal kidney function.

Cases of inflammation of the pancreas (**pancreatitis**) have been reported in patients taking JANUVIA[®]. Pancreatitis can be severe and lead to death.

Cases of **serious skin reactions** can occur and have been reported in patients taking JANUVIA®. These skin reactions are called **Stevens-Johnson syndrome** and **bullous pemphigoid**. They can happen after the first dose or up to 3 months on the drug. You may need treatment in a hospital. You may need to see a dermatologist to diagnose and treat these skin reactions.

INTERACTIONS WITH THIS MEDICATION

Tell your physician or pharmacist about all the medicines you take. This includes prescription and non-prescription medicines, and herbal supplements.

PROPER USE OF THIS MEDICATION

Take JANUVIA® exactly as your physician has prescribed.

Usual adult dose:

100 mg once daily by mouth with or without food. The daily dose may be adjusted in patients with kidney problems.

Overdose:

If you think you have taken too much JANUVIA®, contact your health care professional hospital emergency department or regional poison control centre immediately, even if there are no symptoms.

Missed Dose:

If you miss a dose, take it as soon as you remember. If you do not remember until it is time for your next dose, skip the missed dose and go back to your regular schedule. Do not take a double dose of JANUVIA® on the same day.

SIDE EFFECTS AND WHAT TO DO ABOUT THEM

These are not all the possible side effects that you may have when taking JANUVIA®. If you experience any side effects not listed here, contact your healthcare professional.

Side effects of JANUVIA® include:

- Stuffy or runny nose
- Sore throat
- Vomiting
- Constipation
- Headache
- Joint pain
- Muscle aches
- Arm or leg pain
- Back pain
- Itching
- Blisters

When JANUVIA® is used with metformin and a sulfonylurea medicine, or with insulin (with or without metformin), low blood sugar (hypoglycemia) can occur. Lower doses of the sulfonylurea medicine or insulin may be required while you use JANUVIA®.

Your doctor may do blood tests before you start JANUVIA® and while you take it. They may check your blood sugar, liver function, and how well your kidneys are working. Your doctor will decide when to perform blood tests and will interpret the results.

SERIOUS SIDE EFFECTS, HOW OFTEN THEY HAPPEN AND WHAT TO DO ABOUT THEM

Symptoms / Effects	Talk with your physician or pharmacist		Stop taking drug and call your physician or pharmacist
	Only if severe	In all cases	
Very common			
Hypoglycemia (low blood sugar – when used with metformin and a sulfonylurea, or when used with insulin with or without metformin): shaking, sweating, rapid heartbeat, change in vision, hunger, headache and change in mood.		√	
Rare			
Pancreatitis (inflammation of the pancreas): prolonged severe stomach pain and possible vomiting.			√
Allergic reactions: rash, hives, and swelling of the face, lips, tongue, and throat that may cause difficulty in breathing or swallowing.			√
Serious skin reactions including Stevens-Johnson syndrome, bullous pemphigoid: blisters or breakdown of your skin.		√	
Acute kidney failure (sometimes requiring dialysis): nausea, loss of appetite and weakness, pass little or no urine, breathlessness.			√

If you have a troublesome symptom or side effect that is not listed here or becomes bad enough to interfere with your daily activities, talk to your healthcare professional.

HOW TO STORE IT

Store at room temperature (15°C to 30°C).

Keep JANUVIA® and all medicines safely away from children.

Reporting Side Effects

You can report any suspected side effects associated with the use of health products to Health Canada by.

- Visiting the Web page on Adverse Reaction Reporting (<https://www.canada.ca/en/health-canada/services/drugs-health-products/medeffect-canada/adverse-reaction-reporting.html>) for information on how to report online, by mail or by fax; or
- Calling toll-free at 1-866-234-2345.

NOTE: Contact your health professional if you need information about how to manage your side effects. The Canada Vigilance Program does not provide medical advice.

MORE INFORMATION

If you want more information about JANUVIA®:

- Talk to your healthcare professional
- Find the full product monograph that is prepared for healthcare professionals and includes this Consumer Information by visiting the [Health Canada website](#) or Merck Canada website www.merck.ca or by calling Merck Canada at 1-800-567-2594.

To report an adverse event related to JANUVIA®, please contact 1-800-567-2594.

This leaflet was prepared by Merck Canada Inc.

Last revised: November 1, 2018

® Merck Sharp & Dohme Corp. Used under license.
© 2011, 2018 Merck Canada Inc. All rights reserved.

HIGHLIGHTS OF PRESCRIBING INFORMATION

These highlights do not include all the information needed to use JANUVIA safely and effectively. See full prescribing information for JANUVIA.

JANUVIA® (sitagliptin) tablets, for oral use
Initial U.S. Approval: 2006

INDICATIONS AND USAGE

JANUVIA is a dipeptidyl peptidase-4 (DPP-4) inhibitor indicated as an adjunct to diet and exercise to improve glycemic control in adults with type 2 diabetes mellitus. (1)

Limitations of Use:

- JANUVIA should not be used in patients with type 1 diabetes or for the treatment of diabetic ketoacidosis. (1)
- JANUVIA has not been studied in patients with a history of pancreatitis. (1, 5.1)

DOSAGE AND ADMINISTRATION

The recommended dose of JANUVIA is 100 mg once daily. JANUVIA can be taken with or without food. (2.1)

Dosage adjustment is recommended for patients with eGFR less than 45 mL/min/1.73 m². (2.2)

Dosage Adjustment in Patients with Renal Impairment (2.2)	
eGFR greater than or equal to 30 mL/min/1.73 m ² to less than 45 mL/min/1.73 m ²	eGFR less than 30 mL/min/1.73 m ² (including patients with end stage renal disease [ESRD] on dialysis)
50 mg once daily	25 mg once daily

DOSAGE FORMS AND STRENGTHS

Tablets: 100 mg, 50 mg, and 25 mg (3)

CONTRAINDICATIONS

History of a serious hypersensitivity reaction to sitagliptin, such as anaphylaxis or angioedema (5.5, 6.2)

WARNINGS AND PRECAUTIONS

- There have been postmarketing reports of acute pancreatitis, including fatal and non-fatal hemorrhagic or necrotizing pancreatitis. If pancreatitis is suspected, promptly discontinue JANUVIA. (5.1)
- Heart failure has been observed with two other members of the DPP-4 inhibitor class. Consider risks and benefits of JANUVIA in patients who have known risk factors for heart failure. Monitor patients for signs and symptoms. (5.2)
- There have been postmarketing reports of acute renal failure, sometimes requiring dialysis. Dosage adjustment is recommended in patients with moderate or severe renal impairment and in patients with ESRD. Assessment of renal function is recommended prior to initiating JANUVIA and periodically thereafter. (2.2, 5.3, 6.2)
- There is an increased risk of hypoglycemia when JANUVIA is added to an insulin secretagogue (e.g., sulfonylurea) or insulin therapy. Consider lowering the dose of the sulfonylurea or insulin to reduce the risk of hypoglycemia. (5.4, 7.2)
- There have been postmarketing reports of serious allergic and hypersensitivity reactions in patients treated with JANUVIA such as anaphylaxis, angioedema, and exfoliative skin conditions including Stevens-Johnson syndrome. In such cases, promptly stop JANUVIA, assess for other potential causes, institute appropriate monitoring and treatment, and initiate alternative treatment for diabetes. (5.5, 6.2)
- Severe and disabling arthralgia has been reported in patients taking DPP-4 inhibitors. Consider as a possible cause for severe joint pain and discontinue drug if appropriate. (5.6)
- There have been postmarketing reports of bullous pemphigoid requiring hospitalization in patients taking DPP-4 inhibitors. Tell patients to report development of blisters or erosions. If bullous pemphigoid is suspected, discontinue JANUVIA. (5.7)
- There have been no clinical studies establishing conclusive evidence of macrovascular risk reduction with JANUVIA. (5.8)

ADVERSE REACTIONS

Adverse reactions reported in ≥5% of patients treated with JANUVIA and more commonly than in patients treated with placebo are: upper respiratory tract infection, nasopharyngitis and headache. In the add-on to sulfonylurea and add-on to insulin studies, hypoglycemia was also more commonly reported in patients treated with JANUVIA compared to placebo. (6.1)

To report SUSPECTED ADVERSE REACTIONS, contact Merck Sharp & Dohme Corp., a subsidiary of Merck & Co., Inc., at 1-877-888-4231 or FDA at 1-800-FDA-1088 or www.fda.gov/medwatch.

USE IN SPECIFIC POPULATIONS

- There are no adequate and well-controlled studies in pregnant women. To report drug exposure during pregnancy call 1-800-986-8999. (8.1)

See 17 for PATIENT COUNSELING INFORMATION and Medication Guide.

Revised: 8/2019

FULL PRESCRIBING INFORMATION: CONTENTS*

1 INDICATIONS AND USAGE

2 DOSAGE AND ADMINISTRATION

- 2.1 Recommended Dosing
- 2.2 Recommendations for Use in Renal Impairment

3 DOSAGE FORMS AND STRENGTHS

4 CONTRAINDICATIONS

5 WARNINGS AND PRECAUTIONS

- 5.1 Pancreatitis
- 5.2 Heart Failure
- 5.3 Assessment of Renal Function
- 5.4 Use with Medications Known to Cause Hypoglycemia
- 5.5 Hypersensitivity Reactions
- 5.6 Severe and Disabling Arthralgia
- 5.7 Bullous Pemphigoid
- 5.8 Macrovascular Outcomes

6 ADVERSE REACTIONS

- 6.1 Clinical Trials Experience

- 6.2 Postmarketing Experience

7 DRUG INTERACTIONS

- 7.1 Digoxin
- 7.2 Insulin Secretagogues or Insulin

8 USE IN SPECIFIC POPULATIONS

- 8.1 Pregnancy
- 8.2 Lactation
- 8.4 Pediatric Use
- 8.5 Geriatric Use
- 8.6 Renal Impairment

10 OVERDOSAGE

11 DESCRIPTION

12 CLINICAL PHARMACOLOGY

- 12.1 Mechanism of Action
- 12.2 Pharmacodynamics
- 12.3 Pharmacokinetics

13 NONCLINICAL TOXICOLOGY

- 13.1 Carcinogenesis, Mutagenesis, Impairment of Fertility

14 CLINICAL STUDIES

- 14.1 Monotherapy
- 14.2 Combination Therapy

16 HOW SUPPLIED/STORAGE AND HANDLING
17 PATIENT COUNSELING INFORMATION

*Sections or subsections omitted from the full prescribing information are not listed.

FULL PRESCRIBING INFORMATION

1 INDICATIONS AND USAGE

JANUVIA® is indicated as an adjunct to diet and exercise to improve glycemic control in adults with type 2 diabetes mellitus.

Limitations of Use

JANUVIA should not be used in patients with type 1 diabetes or for the treatment of diabetic ketoacidosis, as it would not be effective in these settings.

JANUVIA has not been studied in patients with a history of pancreatitis. It is unknown whether patients with a history of pancreatitis are at increased risk for the development of pancreatitis while using JANUVIA. [See *Warnings and Precautions (5.1)*.]

2 DOSAGE AND ADMINISTRATION

2.1 Recommended Dosing

The recommended dose of JANUVIA is 100 mg once daily. JANUVIA can be taken with or without food.

2.2 Recommendations for Use in Renal Impairment

For patients with an estimated glomerular filtration rate [eGFR] greater than or equal to 45 mL/min/1.73 m² to less than 90 mL/min/1.73 m², no dosage adjustment for JANUVIA is required.

For patients with moderate renal impairment (eGFR greater than or equal to 30 mL/min/1.73 m² to less than 45 mL/min/1.73 m²), the dose of JANUVIA is 50 mg once daily.

For patients with severe renal impairment (eGFR less than 30 mL/min/1.73 m²) or with end-stage renal disease (ESRD) requiring hemodialysis or peritoneal dialysis, the dose of JANUVIA is 25 mg once daily. JANUVIA may be administered without regard to the timing of dialysis.

Because there is a need for dosage adjustment based upon renal function, assessment of renal function is recommended prior to initiation of JANUVIA and periodically thereafter. There have been postmarketing reports of worsening renal function in patients with renal impairment, some of whom were prescribed inappropriate doses of sitagliptin.

3 DOSAGE FORMS AND STRENGTHS

- 100 mg tablets are beige, round, film-coated tablets with “277” on one side.
- 50 mg tablets are light beige, round, film-coated tablets with “112” on one side.
- 25 mg tablets are pink, round, film-coated tablets with “221” on one side.

4 CONTRAINDICATIONS

History of a serious hypersensitivity reaction to sitagliptin, such as anaphylaxis or angioedema. [See *Warnings and Precautions (5.5)*; *Adverse Reactions (6.2)*.]

5 WARNINGS AND PRECAUTIONS

5.1 Pancreatitis

There have been postmarketing reports of acute pancreatitis, including fatal and non-fatal hemorrhagic or necrotizing pancreatitis, in patients taking JANUVIA. After initiation of JANUVIA, patients should be observed carefully for signs and symptoms of pancreatitis. If pancreatitis is suspected, JANUVIA should promptly be discontinued and appropriate management should be initiated. It is unknown whether patients with a history of pancreatitis are at increased risk for the development of pancreatitis while using JANUVIA.

5.2 Heart Failure

An association between dipeptidyl peptidase-4 (DPP-4) inhibitor treatment and heart failure has been observed in cardiovascular outcomes trials for two other members of the DPP-4 inhibitor class. These trials evaluated patients with type 2 diabetes mellitus and atherosclerotic cardiovascular disease.

Consider the risks and benefits of JANUVIA prior to initiating treatment in patients at risk for heart failure, such as those with a prior history of heart failure and a history of renal impairment, and observe these patients for signs and symptoms of heart failure during therapy. Advise patients of the characteristic symptoms of heart failure and to immediately report such symptoms. If heart failure develops, evaluate and manage according to current standards of care and consider discontinuation of JANUVIA.

5.3 Assessment of Renal Function

Assessment of renal function is recommended prior to initiating JANUVIA and periodically thereafter. A dosage adjustment is recommended in patients with moderate or severe renal impairment and in patients with ESRD requiring hemodialysis or peritoneal dialysis. [See *Dosage and Administration (2.2)*; *Clinical Pharmacology (12.3)*.] Caution should be used to ensure that the correct dose of JANUVIA is prescribed for patients with moderate (eGFR ≥ 30 mL/min/1.73 m² to < 45 mL/min/1.73 m²) or severe (eGFR < 30 mL/min/1.73 m²) renal impairment.

There have been postmarketing reports of worsening renal function, including acute renal failure, sometimes requiring dialysis. A subset of these reports involved patients with renal impairment, some of whom were prescribed inappropriate doses of sitagliptin. A return to baseline levels of renal impairment has been observed with supportive treatment and discontinuation of potentially causative agents. Consideration can be given to cautiously reinitiating JANUVIA if another etiology is deemed likely to have precipitated the acute worsening of renal function.

JANUVIA has not been found to be nephrotoxic in preclinical studies at clinically relevant doses, or in clinical trials.

5.4 Use with Medications Known to Cause Hypoglycemia

When JANUVIA was used in combination with a sulfonylurea or with insulin, medications known to cause hypoglycemia, the incidence of hypoglycemia was increased over that of placebo used in combination with a sulfonylurea or with insulin. [See *Adverse Reactions (6.1)*.] Therefore, a lower dose of sulfonylurea or insulin may be required to reduce the risk of hypoglycemia. [See *Drug Interactions (7.2)*.]

5.5 Hypersensitivity Reactions

There have been postmarketing reports of serious hypersensitivity reactions in patients treated with JANUVIA. These reactions include anaphylaxis, angioedema, and exfoliative skin conditions including Stevens-Johnson syndrome. Onset of these reactions occurred within the first 3 months after initiation of treatment with JANUVIA, with some reports occurring after the first dose. If a hypersensitivity reaction is suspected, discontinue JANUVIA, assess for other potential causes for the event, and institute alternative treatment for diabetes. [See *Adverse Reactions (6.2)*.]

Angioedema has also been reported with other DPP-4 inhibitors. Use caution in a patient with a history of angioedema with another DPP-4 inhibitor because it is unknown whether such patients will be predisposed to angioedema with JANUVIA.

5.6 Severe and Disabling Arthralgia

There have been postmarketing reports of severe and disabling arthralgia in patients taking DPP-4 inhibitors. The time to onset of symptoms following initiation of drug therapy varied from one day to years. Patients experienced relief of symptoms upon discontinuation of the medication. A subset of patients experienced a recurrence of symptoms when restarting the same drug or a different DPP-4 inhibitor. Consider DPP-4 inhibitors as a possible cause for severe joint pain and discontinue drug if appropriate.

5.7 Bullous Pemphigoid

Postmarketing cases of bullous pemphigoid requiring hospitalization have been reported with DPP-4 inhibitor use. In reported cases, patients typically recovered with topical or systemic immunosuppressive treatment and discontinuation of the DPP-4 inhibitor. Tell patients to report development of blisters or erosions while receiving JANUVIA. If bullous pemphigoid is suspected, JANUVIA should be discontinued and referral to a dermatologist should be considered for diagnosis and appropriate treatment.

5.8 Macrovascular Outcomes

There have been no clinical studies establishing conclusive evidence of macrovascular risk reduction with JANUVIA.

6 ADVERSE REACTIONS

6.1 Clinical Trials Experience

Because clinical trials are conducted under widely varying conditions, adverse reaction rates observed in the clinical trials of a drug cannot be directly compared to rates in the clinical trials of another drug and may not reflect the rates observed in practice.

In controlled clinical studies as both monotherapy and combination therapy with metformin, pioglitazone, or rosiglitazone and metformin, the overall incidence of adverse reactions, hypoglycemia, and discontinuation of therapy due to clinical adverse reactions with JANUVIA were similar to placebo. In combination with glimepiride, with or without metformin, the overall incidence of clinical adverse reactions with JANUVIA was higher than with placebo, in part related to a higher incidence of hypoglycemia (see Table 3); the incidence of discontinuation due to clinical adverse reactions was similar to placebo.

Two placebo-controlled monotherapy studies, one of 18- and one of 24-week duration, included patients treated with JANUVIA 100 mg daily, JANUVIA 200 mg daily, and placebo. Five placebo-controlled add-on combination therapy studies were also conducted: one with metformin; one with pioglitazone; one with metformin and rosiglitazone; one with glimepiride (with or without metformin); and one with insulin (with or without metformin). In these trials, patients with inadequate glycemic control on a stable dose of the background therapy were randomized to add-on therapy with JANUVIA 100 mg daily or placebo. The adverse reactions, excluding hypoglycemia, reported regardless of investigator assessment of causality in $\geq 5\%$ of patients treated with JANUVIA 100 mg daily and more commonly than in patients treated with placebo, are shown in Table 1 for the clinical trials of at least 18 weeks duration. Incidences of hypoglycemia are shown in Table 3.

Table 1:
Placebo-Controlled Clinical Studies of JANUVIA Monotherapy or Add-on Combination Therapy with Pioglitazone, Metformin + Rosiglitazone, or Glimepiride +/- Metformin: Adverse Reactions (Excluding Hypoglycemia) Reported in $\geq 5\%$ of Patients and More Commonly than in Patients Given Placebo, Regardless of Investigator Assessment of Causality*

Monotherapy (18 or 24 weeks)	Number of Patients (%)	
	JANUVIA 100 mg	Placebo
	N = 443	N = 363
Nasopharyngitis	23 (5.2)	12 (3.3)
Combination with Pioglitazone (24 weeks)	JANUVIA 100 mg + Pioglitazone	Placebo + Pioglitazone
	N = 175	N = 178
Upper Respiratory Tract Infection	11 (6.3)	6 (3.4)
Headache	9 (5.1)	7 (3.9)
Combination with Metformin + Rosiglitazone (18 weeks)	JANUVIA 100 mg + Metformin + Rosiglitazone	Placebo + Metformin + Rosiglitazone
	N = 181	N = 97
Upper Respiratory Tract Infection	10 (5.5)	5 (5.2)
Nasopharyngitis	11 (6.1)	4 (4.1)
Combination with Glimepiride (+/- Metformin) (24 weeks)	JANUVIA 100 mg + Glimepiride (+/- Metformin)	Placebo + Glimepiride (+/- Metformin)
	N = 222	N = 219
Nasopharyngitis	14 (6.3)	10 (4.6)
Headache	13 (5.9)	5 (2.3)

* Intent-to-treat population

In the 24-week study of patients receiving JANUVIA as add-on combination therapy with metformin, there were no adverse reactions reported regardless of investigator assessment of causality in $\geq 5\%$ of patients and more commonly than in patients given placebo.

In the 24-week study of patients receiving JANUVIA as add-on therapy to insulin (with or without metformin), there were no adverse reactions reported regardless of investigator assessment of causality in $\geq 5\%$ of patients and more commonly than in patients given placebo, except for hypoglycemia (see Table 3).

In the study of JANUVIA as add-on combination therapy with metformin and rosiglitazone (Table 1), through Week 54 the adverse reactions reported regardless of investigator assessment of causality in $\geq 5\%$ of patients treated with JANUVIA and more commonly than in patients treated with placebo were: upper respiratory tract infection (JANUVIA, 15.5%; placebo, 6.2%), nasopharyngitis (11.0%, 9.3%), peripheral edema (8.3%, 5.2%), and headache (5.5%, 4.1%).

In a pooled analysis of the two monotherapy studies, the add-on to metformin study, and the add-on to pioglitazone study, the incidence of selected gastrointestinal adverse reactions in patients treated with JANUVIA was as follows: abdominal pain (JANUVIA 100 mg, 2.3%; placebo, 2.1%), nausea (1.4%, 0.6%), and diarrhea (3.0%, 2.3%).

In an additional, 24-week, placebo-controlled factorial study of initial therapy with sitagliptin in combination with metformin, the adverse reactions reported (regardless of investigator assessment of causality) in $\geq 5\%$ of patients are shown in Table 2.

Table 2:
Initial Therapy with Combination of Sitagliptin and Metformin:
Adverse Reactions Reported (Regardless of Investigator Assessment of Causality) in $\geq 5\%$ of Patients Receiving Combination Therapy (and Greater than in Patients Receiving Metformin alone, Sitagliptin alone, and Placebo)*

	Number of Patients (%)			
	Placebo	Sitagliptin (JANUVIA) 100 mg QD	Metformin 500 or 1000 mg bid [†]	Sitagliptin 50 mg bid + Metformin 500 or 1000 mg bid [†]
	N = 176	N = 179	N = 364 [†]	N = 372 [†]
Upper Respiratory Infection	9 (5.1)	8 (4.5)	19 (5.2)	23 (6.2)
Headache	5 (2.8)	2 (1.1)	14 (3.8)	22 (5.9)

* Intent-to-treat population.

[†] Data pooled for the patients given the lower and higher doses of metformin.

In a 24-week study of initial therapy with JANUVIA in combination with pioglitazone, there were no adverse reactions reported (regardless of investigator assessment of causality) in $\geq 5\%$ of patients and more commonly than in patients given pioglitazone alone.

No clinically meaningful changes in vital signs or in ECG (including in QTc interval) were observed in patients treated with JANUVIA.

In a pooled analysis of 19 double-blind clinical trials that included data from 10,246 patients randomized to receive sitagliptin 100 mg/day (N=5429) or corresponding (active or placebo) control (N=4817), the incidence of acute pancreatitis was 0.1 per 100 patient-years in each group (4 patients with an event in 4708 patient-years for sitagliptin and 4 patients with an event in 3942 patient-years for control). [See *Warnings and Precautions* (5.1).]

Hypoglycemia

In the above studies (N=9), adverse reactions of hypoglycemia were based on all reports of symptomatic hypoglycemia. A concurrent blood glucose measurement was not required although most (74%) reports of hypoglycemia were accompanied by a blood glucose measurement ≤ 70 mg/dL. When JANUVIA was coadministered with a sulfonylurea or with insulin, the percentage of patients with at least one adverse reaction of hypoglycemia was higher than in the corresponding placebo group (Table 3).

Table 3:
Incidence and Rate of Hypoglycemia* in Placebo-Controlled Clinical Studies when JANUVIA was used as Add-On Therapy to Glimepiride (with or without Metformin) or Insulin (with or without Metformin), Regardless of Investigator Assessment of Causality

Add-On to Glimepiride (+/- Metformin) (24 weeks)	JANUVIA 100 mg + Glimepiride (+/- Metformin)	Placebo + Glimepiride (+/- Metformin)
	N = 222	N = 219
Overall (%)	27 (12.2)	4 (1.8)
Rate (episodes/patient-year) [†]	0.59	0.24
Severe (%) [‡]	0 (0.0)	0 (0.0)
Add-On to Insulin (+/- Metformin) (24 weeks)	JANUVIA 100 mg + Insulin (+/- Metformin)	Placebo + Insulin (+/- Metformin)
	N = 322	N = 319
Overall (%)	50 (15.5)	25 (7.8)
Rate (episodes/patient-year) [†]	1.06	0.51
Severe (%) [‡]	2 (0.6)	1 (0.3)

* Adverse reactions of hypoglycemia were based on all reports of symptomatic hypoglycemia; a concurrent glucose measurement was not required; intent-to-treat population.

[†] Based on total number of events (i.e., a single patient may have had multiple events).

[‡] Severe events of hypoglycemia were defined as those events requiring medical assistance or exhibiting depressed level/loss of consciousness or seizure.

In a pooled analysis of the two monotherapy studies, the add-on to metformin study, and the add-on to pioglitazone study, the overall incidence of adverse reactions of hypoglycemia was 1.2% in patients treated with JANUVIA 100 mg and 0.9% in patients treated with placebo.

In the study of JANUVIA as add-on combination therapy with metformin and rosiglitazone, the overall incidence of hypoglycemia was 2.2% in patients given add-on JANUVIA and 0.0% in patients given add-on placebo through Week 18. Through Week 54, the overall incidence of hypoglycemia was 3.9% in patients given add-on JANUVIA and 1.0% in patients given add-on placebo.

In the 24-week, placebo-controlled factorial study of initial therapy with JANUVIA in combination with metformin, the incidence of hypoglycemia was 0.6% in patients given placebo, 0.6% in patients given JANUVIA alone, 0.8% in patients given metformin alone, and 1.6% in patients given JANUVIA in combination with metformin.

In the study of JANUVIA as initial therapy with pioglitazone, one patient taking JANUVIA experienced a severe episode of hypoglycemia. There were no severe hypoglycemia episodes reported in other studies except in the study involving coadministration with insulin.

In an additional, 30-week placebo-controlled, study of patients with type 2 diabetes inadequately controlled with metformin comparing the maintenance of sitagliptin 100 mg versus withdrawal of sitagliptin when initiating basal insulin therapy, the event rate and incidence of documented symptomatic hypoglycemia (blood glucose measurement ≤ 70 mg/dL) did not differ between the sitagliptin and placebo groups.

Laboratory Tests

Across clinical studies, the incidence of laboratory adverse reactions was similar in patients treated with JANUVIA 100 mg compared to patients treated with placebo. A small increase in white blood cell count (WBC) was observed due to an increase in neutrophils. This increase in WBC (of approximately 200 cells/microL vs placebo, in four pooled placebo-controlled clinical studies, with a mean baseline WBC count of approximately 6600 cells/microL) is not considered to be clinically relevant. In a 12-week study of 91 patients with chronic renal insufficiency, 37 patients with moderate renal insufficiency were randomized to JANUVIA 50 mg daily, while 14 patients with the same magnitude of renal impairment were randomized to placebo. Mean (SE) increases in serum creatinine were observed in patients treated with JANUVIA [0.12 mg/dL (0.04)] and in patients treated with placebo [0.07 mg/dL (0.07)]. The clinical significance of this added increase in serum creatinine relative to placebo is not known.

6.2 Postmarketing Experience

Additional adverse reactions have been identified during postapproval use of JANUVIA as monotherapy and/or in combination with other antihyperglycemic agents. Because these reactions are

reported voluntarily from a population of uncertain size, it is generally not possible to reliably estimate their frequency or establish a causal relationship to drug exposure.

Hypersensitivity reactions including anaphylaxis, angioedema, rash, urticaria, cutaneous vasculitis, and exfoliative skin conditions including Stevens-Johnson syndrome [see *Warnings and Precautions (5.5)*]; hepatic enzyme elevations; acute pancreatitis, including fatal and non-fatal hemorrhagic and necrotizing pancreatitis [see *Indications and Usage (1.2)*; *Warnings and Precautions (5.1)*]; worsening renal function, including acute renal failure (sometimes requiring dialysis) [see *Warnings and Precautions (5.3)*]; severe and disabling arthralgia [see *Warnings and Precautions (5.6)*]; bullous pemphigoid [see *Warnings and Precautions (5.7)*]; constipation; vomiting; headache; myalgia; pain in extremity; back pain; pruritus; mouth ulceration; stomatitis; rhabdomyolysis.

7 DRUG INTERACTIONS

7.1 Digoxin

There was a slight increase in the area under the curve (AUC, 11%) and mean peak drug concentration (C_{max} , 18%) of digoxin with the coadministration of 100 mg sitagliptin for 10 days. Patients receiving digoxin should be monitored appropriately. No dosage adjustment of digoxin or JANUVIA is recommended.

7.2 Insulin Secretagogues or Insulin

Coadministration of JANUVIA with an insulin secretagogue (e.g., sulfonylurea) or insulin may require lower doses of the insulin secretagogue or insulin to reduce the risk of hypoglycemia. [See *Warnings and Precautions (5.4)*.]

8 USE IN SPECIFIC POPULATIONS

8.1 Pregnancy

Pregnancy Exposure Registry

There is a pregnancy exposure registry that monitors pregnancy outcomes in women exposed to JANUVIA during pregnancy. Health care providers are encouraged to report any prenatal exposure to JANUVIA by calling the Pregnancy Registry at 1-800-986-8999.

Risk Summary

The limited available data with JANUVIA in pregnant women are not sufficient to inform a drug-associated risk for major birth defects and miscarriage. There are risks to the mother and fetus associated with poorly controlled diabetes in pregnancy [see *Clinical Considerations*]. No adverse developmental effects were observed when sitagliptin was administered to pregnant rats and rabbits during organogenesis at oral doses up to 30-times and 20-times, respectively, the 100 mg clinical dose, based on AUC [see *Data*].

The estimated background risk of major birth defects is 6-10% in women with pre-gestational diabetes with a Hemoglobin A1c >7% and has been reported to be as high as 20-25% in women with a Hemoglobin A1c >10%. In the U.S. general population, the estimated background risk of major birth defects and miscarriage in clinically recognized pregnancies is 2-4% and 15-20%, respectively.

Clinical Considerations

Disease-Associated Maternal and/or Embryo/Fetal Risk

Poorly controlled diabetes in pregnancy increases the maternal risk for diabetic ketoacidosis, pre-eclampsia, spontaneous abortions, preterm delivery, and delivery complications. Poorly controlled diabetes increases the fetal risk for major birth defects, still birth, and macrosomia related morbidity.

Data

Animal Data

In embryo-fetal development studies, sitagliptin administered to pregnant rats and rabbits during organogenesis (gestation day 6 to 20) did not adversely affect developmental outcomes at oral doses up to 250 mg/kg (30-times the 100 mg clinical dose) and 125 mg/kg (20-times the 100 mg clinical dose), respectively, based on AUC. Higher doses in rats associated with maternal toxicity increased the incidence of rib malformations in offspring at 1000 mg/kg, or approximately 100-times the clinical dose, based on AUC. Placental transfer of sitagliptin was observed in pregnant rats and rabbits.

Sitagliptin administered to female rats from gestation day 6 to lactation day 21 caused no functional or behavioral toxicity in offspring of rats at doses up to 1000 mg/kg.

8.2 Lactation

Risk Summary

There is no information regarding the presence of JANUVIA in human milk, the effects on the breastfed infant, or the effects on milk production. Sitagliptin is present in rat milk and therefore possibly present in human milk [see *Data*]. The developmental and health benefits of breastfeeding should be considered along with the mother's clinical need for JANUVIA and any potential adverse effects on the breastfed infant from JANUVIA or from the underlying maternal condition.

Data

Sitagliptin is secreted in the milk of lactating rats at a milk to plasma ratio of 4:1.

8.4 Pediatric Use

Safety and effectiveness of JANUVIA in pediatric patients under 18 years of age have not been established.

8.5 Geriatric Use

Of the total number of subjects (N=3884) in pre-approval clinical safety and efficacy studies of JANUVIA, 725 patients were 65 years and over, while 61 patients were 75 years and over. No overall differences in safety or effectiveness were observed between subjects 65 years and over and younger subjects. While this and other reported clinical experience have not identified differences in responses between the elderly and younger patients, greater sensitivity of some older individuals cannot be ruled out.

Because sitagliptin is substantially excreted by the kidney, and because aging can be associated with reduced renal function, renal function should be assessed more frequently in elderly patients [see *Warnings and Precautions* (5.3); *Clinical Pharmacology* (12.3)].

8.6 Renal Impairment

Sitagliptin is excreted by the kidney, and sitagliptin exposure is increased in patients with renal impairment. Lower dosages are recommended in patients with eGFR less than 45 mL/min/1.73 m² (moderate and severe renal impairment, as well as in ESRD patients requiring dialysis). [See *Dosage and Administration* (2.2); *Clinical Pharmacology* (12.3).]

10 OVERDOSAGE

In the event of an overdose with JANUVIA, contact the Poison Control Center.

In the event of an overdose, it is reasonable to employ supportive measures, e.g., remove unabsorbed material from the gastrointestinal tract, employ clinical monitoring (including obtaining an electrocardiogram), and institute supportive therapy as dictated by the patient's clinical status.

Sitagliptin is modestly dialyzable. In clinical studies, approximately 13.5% of the dose was removed over a 3- to 4-hour hemodialysis session. Prolonged hemodialysis may be considered if clinically appropriate. It is not known if sitagliptin is dialyzable by peritoneal dialysis.

11 DESCRIPTION

JANUVIA Tablets contain sitagliptin phosphate, an orally-active inhibitor of the dipeptidyl peptidase-4 (DPP-4) enzyme.

Sitagliptin phosphate monohydrate is described chemically as 7-[(3*R*)-3-amino-1-oxo-4-(2,4,5-trifluorophenyl)butyl]-5,6,7,8-tetrahydro-3-(trifluoromethyl)-1,2,4-triazolo[4,3-*a*]pyrazine phosphate (1:1) monohydrate.

The empirical formula is C₁₆H₁₅F₆N₅O•H₃PO₄•H₂O and the molecular weight is 523.32. The structural formula is:

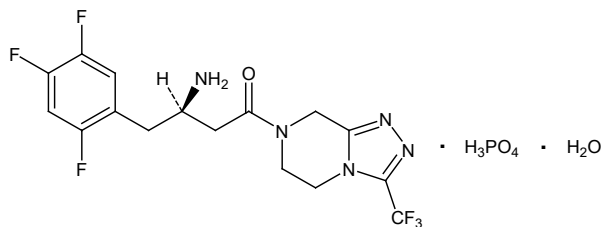

Sitagliptin phosphate monohydrate is a white to off-white, crystalline, non-hygroscopic powder. It is soluble in water and N,N-dimethyl formamide; slightly soluble in methanol; very slightly soluble in ethanol, acetone, and acetonitrile; and insoluble in isopropanol and isopropyl acetate.

Each film-coated tablet of JANUVIA contains 32.13, 64.25, or 128.5 mg of sitagliptin phosphate monohydrate, which is equivalent to 25, 50, or 100 mg, respectively, of free base and the following inactive ingredients: microcrystalline cellulose, anhydrous dibasic calcium phosphate, croscarmellose sodium, magnesium stearate, and sodium stearyl fumarate. In addition, the film coating contains the following inactive ingredients: polyvinyl alcohol, polyethylene glycol, talc, titanium dioxide, red iron oxide, and yellow iron oxide.

12 CLINICAL PHARMACOLOGY

12.1 Mechanism of Action

Sitagliptin is a DPP-4 inhibitor, which is believed to exert its actions in patients with type 2 diabetes mellitus by slowing the inactivation of incretin hormones. Concentrations of the active intact hormones are increased by sitagliptin, thereby increasing and prolonging the action of these hormones. Incretin hormones, including glucagon-like peptide-1 (GLP-1) and glucose-dependent insulinotropic polypeptide (GIP), are released by the intestine throughout the day, and levels are increased in response to a meal. These hormones are rapidly inactivated by the enzyme, DPP-4. The incretins are part of an endogenous system involved in the physiologic regulation of glucose homeostasis. When blood glucose concentrations are normal or elevated, GLP-1 and GIP increase insulin synthesis and release from pancreatic beta cells by intracellular signaling pathways involving cyclic AMP. GLP-1 also lowers glucagon secretion from pancreatic alpha cells, leading to reduced hepatic glucose production. By increasing and prolonging active incretin levels, sitagliptin increases insulin release and decreases glucagon levels in the circulation in a glucose-dependent manner. Sitagliptin demonstrates selectivity for DPP-4 and does not inhibit DPP-8 or DPP-9 activity *in vitro* at concentrations approximating those from therapeutic doses.

12.2 Pharmacodynamics

General

In patients with type 2 diabetes mellitus, administration of sitagliptin led to inhibition of DPP-4 enzyme activity for a 24-hour period. After an oral glucose load or a meal, this DPP-4 inhibition resulted in a 2- to 3-fold increase in circulating levels of active GLP-1 and GIP, decreased glucagon concentrations, and increased responsiveness of insulin release to glucose, resulting in higher C-peptide and insulin concentrations. The rise in insulin with the decrease in glucagon was associated with lower fasting glucose concentrations and reduced glucose excursion following an oral glucose load or a meal.

In studies with healthy subjects, sitagliptin did not lower blood glucose or cause hypoglycemia.

Sitagliptin and Metformin hydrochloride Coadministration

In a two-day study in healthy subjects, sitagliptin alone increased active GLP-1 concentrations, whereas metformin alone increased active and total GLP-1 concentrations to similar extents. Coadministration of sitagliptin and metformin had an additive effect on active GLP-1 concentrations. Sitagliptin, but not metformin, increased active GIP concentrations. It is unclear how these findings relate to changes in glycemic control in patients with type 2 diabetes mellitus.

Cardiac Electrophysiology

In a randomized, placebo-controlled crossover study, 79 healthy subjects were administered a single oral dose of sitagliptin 100 mg, sitagliptin 800 mg (8 times the recommended dose), and placebo. At the recommended dose of 100 mg, there was no effect on the QTc interval obtained at the peak plasma concentration, or at any other time during the study. Following the 800 mg dose, the maximum

increase in the placebo-corrected mean change in QTc from baseline was observed at 3 hours postdose and was 8.0 msec. This increase is not considered to be clinically significant. At the 800 mg dose, peak sitagliptin plasma concentrations were approximately 11 times higher than the peak concentrations following a 100-mg dose.

In patients with type 2 diabetes mellitus administered sitagliptin 100 mg (N=81) or sitagliptin 200 mg (N=63) daily, there were no meaningful changes in QTc interval based on ECG data obtained at the time of expected peak plasma concentration.

12.3 Pharmacokinetics

The pharmacokinetics of sitagliptin have been extensively characterized in healthy subjects and patients with type 2 diabetes mellitus. Following a single oral 100-mg dose to healthy volunteers, mean plasma AUC of sitagliptin was 8.52 $\mu\text{M}\cdot\text{hr}$, C_{max} was 950 nM, and apparent terminal half-life ($t_{1/2}$) was 12.4 hours. Plasma AUC of sitagliptin increased in a dose-proportional manner and increased approximately 14% following 100 mg doses at steady-state compared to the first dose. The intra-subject and inter-subject coefficients of variation for sitagliptin AUC were small (5.8% and 15.1%). The pharmacokinetics of sitagliptin was generally similar in healthy subjects and in patients with type 2 diabetes mellitus.

Absorption

After oral administration of a 100 mg dose to healthy subjects, sitagliptin was rapidly absorbed with peak plasma concentrations (median T_{max}) occurring 1 to 4 hours postdose. The absolute bioavailability of sitagliptin is approximately 87%.

Effect of Food

Coadministration of a high-fat meal with sitagliptin had no effect on the pharmacokinetics of sitagliptin.

Distribution

The mean volume of distribution at steady state following a single 100-mg intravenous dose of sitagliptin to healthy subjects is approximately 198 liters. The fraction of sitagliptin reversibly bound to plasma proteins is low (38%).

Elimination

Approximately 79% of sitagliptin is excreted unchanged in the urine with metabolism being a minor pathway of elimination. The apparent terminal $t_{1/2}$ following a 100 mg oral dose of sitagliptin was approximately 12.4 hours and renal clearance was approximately 350 mL/min.

Metabolism

Following a [^{14}C]sitagliptin oral dose, approximately 16% of the radioactivity was excreted as metabolites of sitagliptin. Six metabolites were detected at trace levels and are not expected to contribute to the plasma DPP-4 inhibitory activity of sitagliptin. *In vitro* studies indicated that the primary enzyme responsible for the limited metabolism of sitagliptin was CYP3A4, with contribution from CYP2C8.

Excretion

Following administration of an oral [^{14}C]sitagliptin dose to healthy subjects, approximately 100% of the administered radioactivity was eliminated in feces (13%) or urine (87%) within one week of dosing.

Elimination of sitagliptin occurs primarily via renal excretion and involves active tubular secretion. Sitagliptin is a substrate for human organic anion transporter-3 (hOAT-3), which may be involved in the renal elimination of sitagliptin. The clinical relevance of hOAT-3 in sitagliptin transport has not been established. Sitagliptin is also a substrate of P-glycoprotein (P-gp), which may also be involved in mediating the renal elimination of sitagliptin. However, cyclosporine, a P-gp inhibitor, did not reduce the renal clearance of sitagliptin.

Specific Populations

Patients with Renal Impairment

An approximately 2-fold increase in the plasma AUC of sitagliptin was observed in patients with moderate renal impairment with eGFR of 30 to less than 45 mL/min/1.73 m², and an approximately 4-fold increase was observed in patients with severe renal impairment, including patients with ESRD on hemodialysis, as compared to normal healthy control subjects.

Patients with Hepatic Impairment

In patients with moderate hepatic impairment (Child-Pugh score 7 to 9), mean AUC and C_{max} of sitagliptin increased approximately 21% and 13%, respectively, compared to healthy matched controls

following administration of a single 100-mg dose of sitagliptin. These differences are not considered to be clinically meaningful.

There is no clinical experience in patients with severe hepatic impairment (Child-Pugh score >9).

Effects of Age, Body Mass Index (BMI), Gender, and Race

Based on a population pharmacokinetic analysis or a composite analysis of available pharmacokinetic data, BMI, gender, and race do not have a clinically meaningful effect on the pharmacokinetics of sitagliptin. When the effects of age on renal function are taken into account, age alone did not have a clinically meaningful impact on the pharmacokinetics of sitagliptin based on a population pharmacokinetic analysis. Elderly subjects (65 to 80 years) had approximately 19% higher plasma concentrations of sitagliptin compared to younger subjects.

Pediatric Patients

Studies characterizing the pharmacokinetics of sitagliptin in pediatric patients have not been performed.

Drug Interaction Studies

In Vitro Assessment of Drug Interactions

Sitagliptin is not an inhibitor of CYP isozymes CYP3A4, 2C8, 2C9, 2D6, 1A2, 2C19 or 2B6, and is not an inducer of CYP3A4. Sitagliptin is a P-gp substrate, but does not inhibit P-gp mediated transport of digoxin. Based on these results, sitagliptin is considered unlikely to cause interactions with other drugs that utilize these pathways.

Sitagliptin is not extensively bound to plasma proteins. Therefore, the propensity of sitagliptin to be involved in clinically meaningful drug-drug interactions mediated by plasma protein binding displacement is very low.

In Vivo Assessment of Drug Interactions

Effects of Sitagliptin on Other Drugs

In clinical studies, sitagliptin did not meaningfully alter the pharmacokinetics of metformin, glyburide, simvastatin, rosiglitazone, digoxin, warfarin, or an oral contraceptive (ethinyl estradiol and norethindrone) (Table 4), providing *in vivo* evidence of a low propensity for causing drug interactions with substrates of CYP3A4, CYP2C8, CYP2C9, P-gp, and organic cationic transporter (OCT).

**Table 4:
Effect of Sitagliptin on Systemic Exposure of Coadministered Drugs**

Coadministered Drug	Dose of Coadministered Drug*	Dose of Sitagliptin*	Geometric Mean Ratio (ratio with/without sitagliptin) No Effect = 1.00		
				AUC [†]	C _{max}
Digoxin	0.25 mg [‡] once daily for 10 days	100 mg [‡] once daily for 10 days	Digoxin	1.11 [§]	1.18
Glyburide	1.25 mg	200 mg [‡] once daily for 6 days	Glyburide	1.09	1.01
Simvastatin	20 mg	200 mg [‡] once daily for 5 days	Simvastatin	0.85 [¶]	0.80
			Simvastatin Acid	1.12 [¶]	1.06
Rosiglitazone	4 mg	200 mg [‡] once daily for 5 days	Rosiglitazone	0.98	0.99
Warfarin	30 mg single dose on day 5	200 mg [‡] once daily for 11 days	S(-) Warfarin	0.95	0.89
			R(+) Warfarin	0.99	0.89
Ethinyl estradiol and norethindrone	21 days once daily of 35 µg ethinyl estradiol with norethindrone 0.5 mg x 7 days, 0.75 mg x 7 days, 1.0 mg x 7 days	200 mg [‡] once daily for 21 days	Ethinyl estradiol	0.99	0.97
			Norethindrone	1.03	0.98
Metformin	1000 mg [‡] twice daily for 14 days	50 mg [‡] twice daily for 7 days	Metformin	1.02 [#]	0.97

- * All doses administered as single dose unless otherwise specified.
† AUC is reported as AUC_{0-∞} unless otherwise specified.
‡ Multiple dose.
§ AUC_{0-24hr}.
¶ AUC_{0-last}.
AUC_{0-12hr}.

Effects of Other Drugs on Sitagliptin

Clinical data described below suggest that sitagliptin is not susceptible to clinically meaningful interactions by coadministered medications (Table 5).

Table 5:
Effect of Coadministered Drugs on Systemic Exposure of Sitagliptin

Coadministered Drug	Dose of Coadministered Drug*	Dose of Sitagliptin*	Geometric Mean Ratio (ratio with/without coadministered drug) No Effect = 1.00		
				AUC [†]	C _{max}
Cyclosporine	600 mg once daily	100 mg once daily	Sitagliptin	1.29	1.68
Metformin	1000 mg [‡] twice daily for 14 days	50 mg [‡] twice daily for 7 days	Sitagliptin	1.02 [§]	1.05

- * All doses administered as single dose unless otherwise specified.
† AUC is reported as AUC_{0-∞} unless otherwise specified.
‡ Multiple dose.
§ AUC_{0-12hr}.

13 NONCLINICAL TOXICOLOGY

13.1 Carcinogenesis, Mutagenesis, Impairment of Fertility

A two-year carcinogenicity study was conducted in male and female rats given oral doses of sitagliptin of 50, 150, and 500 mg/kg/day. There was an increased incidence of combined liver adenoma/carcinoma in males and females and of liver carcinoma in females at 500 mg/kg. This dose results in exposures approximately 60 times the human exposure at the maximum recommended daily adult human dose (MRHD) of 100 mg/day based on AUC comparisons. Liver tumors were not observed at 150 mg/kg, approximately 20 times the human exposure at the MRHD. A two-year carcinogenicity study was conducted in male and female mice given oral doses of sitagliptin of 50, 125, 250, and 500 mg/kg/day. There was no increase in the incidence of tumors in any organ up to 500 mg/kg, approximately 70 times human exposure at the MRHD. Sitagliptin was not mutagenic or clastogenic with or without metabolic activation in the Ames bacterial mutagenicity assay, a Chinese hamster ovary (CHO) chromosome aberration assay, an *in vitro* cytogenetics assay in CHO, an *in vitro* rat hepatocyte DNA alkaline elution assay, and an *in vivo* micronucleus assay.

In rat fertility studies with oral gavage doses of 125, 250, and 1000 mg/kg, males were treated for 4 weeks prior to mating, during mating, up to scheduled termination (approximately 8 weeks total) and females were treated 2 weeks prior to mating through gestation day 7. No adverse effect on fertility was observed at 125 mg/kg (approximately 12 times human exposure at the MRHD of 100 mg/day based on AUC comparisons). At higher doses, nondose-related increased resorptions in females were observed (approximately 25 and 100 times human exposure at the MRHD based on AUC comparison).

14 CLINICAL STUDIES

There were approximately 5200 patients with type 2 diabetes randomized in nine double-blind, placebo-controlled clinical safety and efficacy studies conducted to evaluate the effects of sitagliptin on glycemic control. In a pooled analysis of seven of these studies, the ethnic/racial distribution was approximately 59% white, 20% Hispanic, 10% Asian, 6% black, and 6% other groups. Patients had an overall mean age of approximately 55 years (range 18 to 87 years). In addition, an active (glipizide)-controlled study of 52-weeks duration was conducted in 1172 patients with type 2 diabetes who had inadequate glycemic control on metformin.

In patients with type 2 diabetes, treatment with JANUVIA produced clinically significant improvements in hemoglobin A1C, fasting plasma glucose (FPG) and 2-hour post-prandial glucose (PPG) compared to placebo.

14.1 Monotherapy

A total of 1262 patients with type 2 diabetes participated in two double-blind, placebo-controlled studies, one of 18-week and another of 24-week duration, to evaluate the efficacy and safety of JANUVIA monotherapy. In both monotherapy studies, patients currently on an antihyperglycemic agent discontinued the agent, and underwent a diet, exercise, and drug washout period of about 7 weeks. Patients with inadequate glycemic control (A1C 7% to 10%) after the washout period were randomized after completing a 2-week single-blind placebo run-in period; patients not currently on antihyperglycemic agents (off therapy for at least 8 weeks) with inadequate glycemic control (A1C 7% to 10%) were randomized after completing the 2-week single-blind placebo run-in period. In the 18-week study, 521 patients were randomized to placebo, JANUVIA 100 mg, or JANUVIA 200 mg, and in the 24-week study 741 patients were randomized to placebo, JANUVIA 100 mg, or JANUVIA 200 mg. Patients who failed to meet specific glycemic goals during the studies were treated with metformin rescue, added on to placebo or JANUVIA.

Treatment with JANUVIA at 100 mg daily provided significant improvements in A1C, FPG, and 2-hour PPG compared to placebo (Table 6). In the 18-week study, 9% of patients receiving JANUVIA 100 mg and 17% who received placebo required rescue therapy. In the 24-week study, 9% of patients receiving JANUVIA 100 mg and 21% of patients receiving placebo required rescue therapy. The improvement in A1C compared to placebo was not affected by gender, age, race, prior antihyperglycemic therapy, or baseline BMI. As is typical for trials of agents to treat type 2 diabetes, the mean reduction in A1C with JANUVIA appears to be related to the degree of A1C elevation at baseline. In these 18- and 24-week studies, among patients who were not on an antihyperglycemic agent at study entry, the reductions from baseline in A1C were -0.7% and -0.8%, respectively, for those given JANUVIA, and -0.1% and -0.2%, respectively, for those given placebo. Overall, the 200 mg daily dose did not provide greater glycemic efficacy than the 100 mg daily dose. The effect of JANUVIA on lipid endpoints was similar to placebo. Body weight did not increase from baseline with JANUVIA therapy in either study, compared to a small reduction in patients given placebo.

Table 6:
Glycemic Parameters in 18- and 24-Week Placebo-Controlled Studies of JANUVIA in Patients with Type 2 Diabetes*

	18-Week Study		24-Week Study	
	JANUVIA 100 mg	Placebo	JANUVIA 100 mg	Placebo
A1C (%)	N = 193	N = 103	N = 229	N = 244
Baseline (mean)	8.0	8.1	8.0	8.0
Change from baseline (adjusted mean [†])	-0.5	0.1	-0.6	0.2
Difference from placebo (adjusted mean [†]) (95% CI)	-0.6 [‡] (-0.8, -0.4)		-0.8 [‡] (-1.0, -0.6)	
Patients (%) achieving A1C <7%	69 (36%)	16 (16%)	93 (41%)	41 (17%)
FPG (mg/dL)	N = 201	N = 107	N = 234	N = 247
Baseline (mean)	180	184	170	176
Change from baseline (adjusted mean [†])	-13	7	-12	5
Difference from placebo (adjusted mean [†]) (95% CI)	-20 [‡] (-31, -9)		-17 [‡] (-24, -10)	
2-hour PPG (mg/dL)	§	§	N = 201	N = 204
Baseline (mean)			257	271
Change from baseline (adjusted mean [†])			-49	-2
Difference from placebo (adjusted mean [†]) (95% CI)			-47 [‡] (-59, -34)	

* Intent-to-treat population using last observation on study prior to metformin rescue therapy.

[†] Least squares means adjusted for prior antihyperglycemic therapy status and baseline value.

[‡] p<0.001 compared to placebo.

[§] Data not available.

Additional Monotherapy Study

A multinational, randomized, double-blind, placebo-controlled study was also conducted to assess the safety and tolerability of JANUVIA in 91 patients with type 2 diabetes and chronic renal insufficiency (creatinine clearance <50 mL/min). Patients with moderate renal insufficiency received 50 mg daily of JANUVIA and those with severe renal insufficiency or with ESRD on hemodialysis or peritoneal dialysis received 25 mg daily. In this study, the safety and tolerability of JANUVIA were generally similar to placebo. A small increase in serum creatinine was reported in patients with moderate renal insufficiency treated with JANUVIA relative to those on placebo. In addition, the reductions in A1C and FPG with JANUVIA compared to placebo were generally similar to those observed in other monotherapy studies. [See *Clinical Pharmacology* (12.3).]

14.2 Combination Therapy

Add-on Combination Therapy with Metformin

A total of 701 patients with type 2 diabetes participated in a 24-week, randomized, double-blind, placebo-controlled study designed to assess the efficacy of JANUVIA in combination with metformin. Patients already on metformin (N=431) at a dose of at least 1500 mg per day were randomized after completing a 2-week single-blind placebo run-in period. Patients on metformin and another antihyperglycemic agent (N=229) and patients not on any antihyperglycemic agents (off therapy for at least 8 weeks, N=41) were randomized after a run-in period of approximately 10 weeks on metformin (at a dose of at least 1500 mg per day) in monotherapy. Patients with inadequate glycemic control (A1C 7% to 10%) were randomized to the addition of either 100 mg of JANUVIA or placebo, administered once daily. Patients who failed to meet specific glycemic goals during the studies were treated with pioglitazone rescue.

In combination with metformin, JANUVIA provided significant improvements in A1C, FPG, and 2-hour PPG compared to placebo with metformin (Table 7). Rescue glycemic therapy was used in 5% of patients treated with JANUVIA 100 mg and 14% of patients treated with placebo. A similar decrease in body weight was observed for both treatment groups.

**Table 7:
Glycemic Parameters at Final Visit (24-Week Study)
for JANUVIA in Add-on Combination Therapy with Metformin***

	JANUVIA 100 mg + Metformin	Placebo + Metformin
A1C (%)	N = 453	N = 224
Baseline (mean)	8.0	8.0
Change from baseline (adjusted mean [†])	-0.7	-0.0
Difference from placebo + metformin (adjusted mean [†]) (95% CI)	-0.7 [‡] (-0.8, -0.5)	
Patients (%) achieving A1C <7%	213 (47%)	41 (18%)
FPG (mg/dL)	N = 454	N = 226
Baseline (mean)	170	174
Change from baseline (adjusted mean [†])	-17	9
Difference from placebo + metformin (adjusted mean [†]) (95% CI)	-25 [‡] (-31, -20)	
2-hour PPG (mg/dL)	N = 387	N = 182
Baseline (mean)	275	272
Change from baseline (adjusted mean [†])	-62	-11
Difference from placebo + metformin (adjusted mean [†]) (95% CI)	-51 [‡] (-61, -41)	

* Intent-to-treat population using last observation on study prior to pioglitazone rescue therapy.

[†] Least squares means adjusted for prior antihyperglycemic therapy and baseline value.

[‡] p<0.001 compared to placebo + metformin.

Initial Combination Therapy with Metformin

A total of 1091 patients with type 2 diabetes and inadequate glycemic control on diet and exercise participated in a 24-week, randomized, double-blind, placebo-controlled factorial study designed to assess the efficacy of sitagliptin as initial therapy in combination with metformin. Patients on an antihyperglycemic agent (N=541) discontinued the agent, and underwent a diet, exercise, and drug washout period of up to 12 weeks duration. After the washout period, patients with inadequate glycemic control (A1C 7.5% to 11%) were randomized after completing a 2-week single-blind placebo run-in period. Patients not on antihyperglycemic agents at study entry (N=550) with inadequate glycemic control (A1C 7.5% to 11%) immediately entered the 2-week single-blind placebo run-in period and then were randomized. Approximately equal numbers of patients were randomized to receive initial therapy with placebo, 100 mg of JANUVIA once daily, 500 mg or 1000 mg of metformin twice daily, or 50 mg of sitagliptin twice daily in combination with 500 mg or 1000 mg of metformin twice daily. Patients who failed to meet specific glycemic goals during the study were treated with glyburide (glibenclamide) rescue.

Initial therapy with the combination of JANUVIA and metformin provided significant improvements in A1C, FPG, and 2-hour PPG compared to placebo, to metformin alone, and to JANUVIA alone (Table 8, Figure 1). Mean reductions from baseline in A1C were generally greater for patients with higher baseline A1C values. For patients not on an antihyperglycemic agent at study entry, mean reductions from baseline in A1C were: JANUVIA 100 mg once daily, -1.1%; metformin 500 mg bid, -1.1%; metformin 1000 mg bid, -1.2%; sitagliptin 50 mg bid with metformin 500 mg bid, -1.6%; sitagliptin 50 mg bid with metformin 1000 mg bid, -1.9%; and for patients receiving placebo, -0.2%. Lipid effects were generally neutral. The decrease in body weight in the groups given sitagliptin in combination with metformin was similar to that in the groups given metformin alone or placebo.

**Table 8:
Glycemic Parameters at Final Visit (24-Week Study)
for Sitagliptin and Metformin, Alone and in Combination as Initial Therapy***

	Placebo	Sitagliptin (JANUVIA) 100 mg QD	Metformin 500 mg bid	Metformin 1000 mg bid	Sitagliptin 50 mg bid + Metformin 500 mg bid	Sitagliptin 50 mg bid + Metformin 1000 mg bid
A1C (%)	N = 165	N = 175	N = 178	N = 177	N = 183	N = 178
Baseline (mean)	8.7	8.9	8.9	8.7	8.8	8.8
Change from baseline (adjusted mean [†])	0.2	-0.7	-0.8	-1.1	-1.4	-1.9
Difference from placebo (adjusted mean [†]) (95% CI)		-0.8 [‡] (-1.1, -0.6)	-1.0 [‡] (-1.2, -0.8)	-1.3 [‡] (-1.5, -1.1)	-1.6 [‡] (-1.8, -1.3)	-2.1 [‡] (-2.3, -1.8)
Patients (%) achieving A1C <7%	15 (9%)	35 (20%)	41 (23%)	68 (38%)	79 (43%)	118 (66%)
% Patients receiving rescue medication	32	21	17	12	8	2
FPG (mg/dL)	N = 169	N = 178	N = 179	N = 179	N = 183	N = 180
Baseline (mean)	196	201	205	197	204	197
Change from baseline (adjusted mean [†])	6	-17	-27	-29	-47	-64
Difference from placebo (adjusted mean [†]) (95% CI)		-23 [‡] (-33, -14)	-33 [‡] (-43, -24)	-35 [‡] (-45, -26)	-53 [‡] (-62, -43)	-70 [‡] (-79, -60)
2-hour PPG (mg/dL)	N = 129	N = 136	N = 141	N = 138	N = 147	N = 152
Baseline (mean)	277	285	293	283	292	287
Change from baseline (adjusted mean [†])	0	-52	-53	-78	-93	-117
Difference from placebo (adjusted mean [†]) (95% CI)		-52 [‡] (-67, -37)	-54 [‡] (-69, -39)	-78 [‡] (-93, -63)	-93 [‡] (-107, -78)	-117 [‡] (-131, -102)

* Intent-to-treat population using last observation on study prior to glyburide (glibenclamide) rescue therapy.

[†] Least squares means adjusted for prior antihyperglycemic therapy status and baseline value.

[‡] p<0.001 compared to placebo.

Figure 1: Mean Change from Baseline for A1C (%) over 24 Weeks with Sitagliptin and Metformin, Alone and in Combination as Initial Therapy in Patients with Type 2 Diabetes*

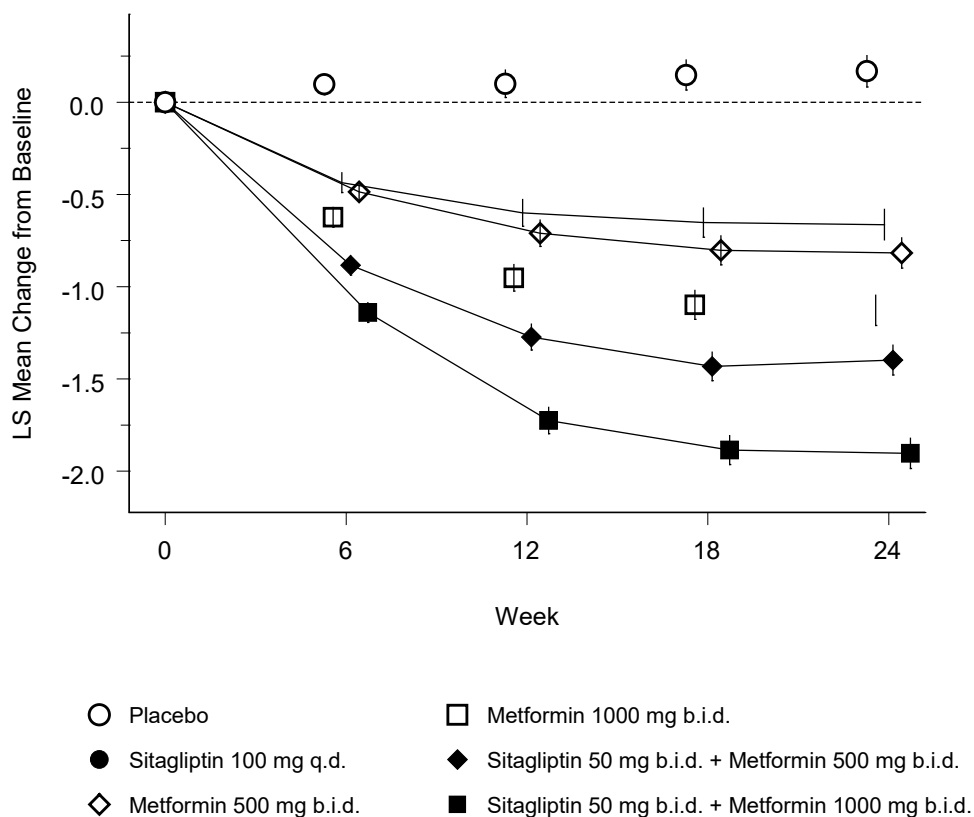

*All Patients Treated Population: least squares means adjusted for prior antihyperglycemic therapy and baseline value.

Initial combination therapy or maintenance of combination therapy may not be appropriate for all patients. These management options are left to the discretion of the health care provider.

Active-Controlled Study vs Glipizide in Combination with Metformin

The efficacy of JANUVIA was evaluated in a 52-week, double-blind, glipizide-controlled noninferiority trial in patients with type 2 diabetes. Patients not on treatment or on other antihyperglycemic agents entered a run-in treatment period of up to 12 weeks duration with metformin monotherapy (dose of ≥ 1500 mg per day) which included washout of medications other than metformin, if applicable. After the run-in period, those with inadequate glycemic control (A1C 6.5% to 10%) were randomized 1:1 to the addition of JANUVIA 100 mg once daily or glipizide for 52 weeks. Patients receiving glipizide were given an initial dosage of 5 mg/day and then electively titrated over the next 18 weeks to a maximum dosage of 20 mg/day as needed to optimize glycemic control. Thereafter, the glipizide dose was to be kept constant, except for down-titration to prevent hypoglycemia. The mean dose of glipizide after the titration period was 10 mg.

After 52 weeks, JANUVIA and glipizide had similar mean reductions from baseline in A1C in the intent-to-treat analysis (Table 9). These results were consistent with the per protocol analysis (Figure 2). A conclusion in favor of the non-inferiority of JANUVIA to glipizide may be limited to patients with baseline A1C comparable to those included in the study (over 70% of patients had baseline A1C <8% and over 90% had A1C <9%).

Table 9:
Glycemic Parameters in a 52-Week Study Comparing
JANUVIA to Glipizide as Add-On Therapy in Patients Inadequately
Controlled on Metformin
(Intent-to-Treat Population)*

	JANUVIA 100 mg	Glipizide
A1C (%)	N = 576	N = 559
Baseline (mean)	7.7	7.6
Change from baseline (adjusted mean [†])	-0.5	-0.6
FPG (mg/dL)	N = 583	N = 568
Baseline (mean)	166	164
Change from baseline (adjusted mean [†])	-8	-8

* The intent-to-treat analysis used the patients' last observation in the study prior to discontinuation.
[†] Least squares means adjusted for prior antihyperglycemic therapy status and baseline A1C value.

Figure 2: Mean Change from Baseline for A1C (%) Over 52 Weeks in a Study
Comparing JANUVIA to Glipizide as Add-On Therapy in
Patients Inadequately Controlled on Metformin
(Per Protocol Population)*

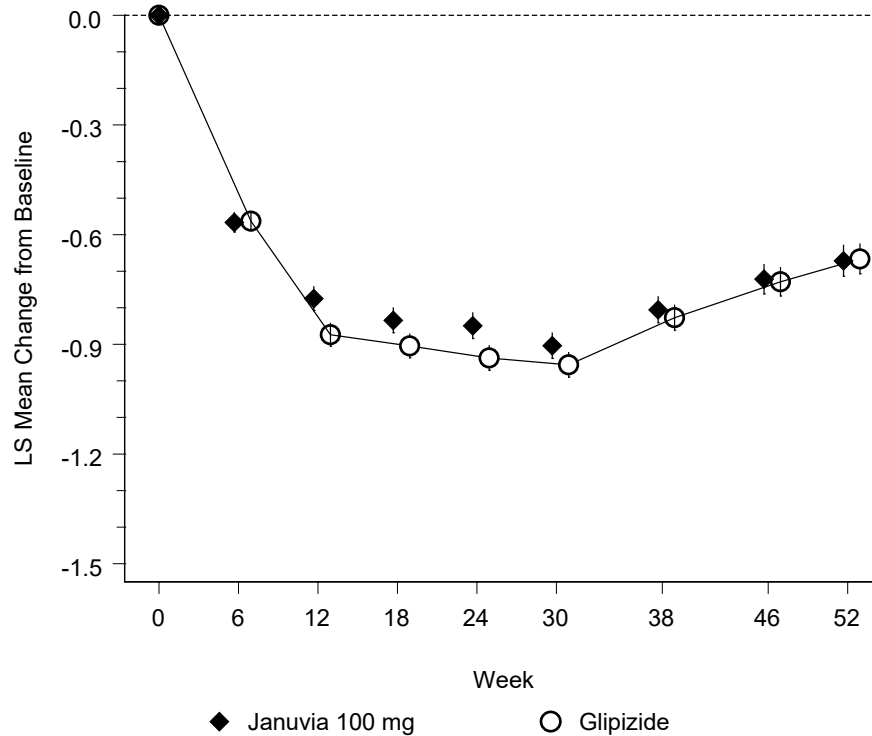

* The per protocol population (mean baseline A1C of 7.5%) included patients without major protocol violations who had observations at baseline and at Week 52.

The incidence of hypoglycemia in the JANUVIA group (4.9%) was significantly ($p < 0.001$) lower than that in the glipizide group (32.0%). Patients treated with JANUVIA exhibited a significant mean decrease from baseline in body weight compared to a significant weight gain in patients administered glipizide (-1.5 kg vs +1.1 kg).

Add-on Combination Therapy with Pioglitazone

A total of 353 patients with type 2 diabetes participated in a 24-week, randomized, double-blind, placebo-controlled study designed to assess the efficacy of JANUVIA in combination with pioglitazone. Patients on any oral antihyperglycemic agent in monotherapy (N=212) or on a PPAR γ agent in combination therapy (N=106) or not on an antihyperglycemic agent (off therapy for at least 8 weeks, N=34) were switched to monotherapy with pioglitazone (at a dose of 30-45 mg per day), and completed a run-in period of approximately 12 weeks in duration. After the run-in period on pioglitazone monotherapy, patients with inadequate glycemic control (A1C 7% to 10%) were randomized to the addition of either 100 mg of JANUVIA or placebo, administered once daily. Patients who failed to meet specific glycemic goals during the studies were treated with metformin rescue. Glycemic endpoints measured were A1C and fasting glucose.

In combination with pioglitazone, JANUVIA provided significant improvements in A1C and FPG compared to placebo with pioglitazone (Table 10). Rescue therapy was used in 7% of patients treated with JANUVIA 100 mg and 14% of patients treated with placebo. There was no significant difference between JANUVIA and placebo in body weight change.

Table 10:
Glycemic Parameters at Final Visit (24-Week Study)
for JANUVIA in Add-on Combination Therapy with Pioglitazone*

	JANUVIA 100 mg + Pioglitazone	Placebo + Pioglitazone
A1C (%)	N = 163	N = 174
Baseline (mean)	8.1	8.0
Change from baseline (adjusted mean [†])	-0.9	-0.2
Difference from placebo + pioglitazone (adjusted mean [†]) (95% CI)	-0.7 [‡] (-0.9, -0.5)	
Patients (%) achieving A1C <7%	74 (45%)	40 (23%)
FPG (mg/dL)	N = 163	N = 174
Baseline (mean)	168	166
Change from baseline (adjusted mean [†])	-17	1
Difference from placebo + pioglitazone (adjusted mean [†]) (95% CI)	-18 [‡] (-24, -11)	

* Intent-to-treat population using last observation on study prior to metformin rescue therapy.

[†] Least squares means adjusted for prior antihyperglycemic therapy status and baseline value.

[‡] p<0.001 compared to placebo + pioglitazone.

Initial Combination Therapy with Pioglitazone

A total of 520 patients with type 2 diabetes and inadequate glycemic control on diet and exercise participated in a 24-week, randomized, double-blind study designed to assess the efficacy of JANUVIA as initial therapy in combination with pioglitazone. Patients not on antihyperglycemic agents at study entry (<4 weeks cumulative therapy over the past 2 years, and with no treatment over the prior 4 months) with inadequate glycemic control (A1C 8% to 12%) immediately entered the 2-week single-blind placebo run-in period and then were randomized. Approximately equal numbers of patients were randomized to receive initial therapy with 100 mg of JANUVIA in combination with 30 mg of pioglitazone once daily or 30 mg of pioglitazone once daily as monotherapy. There was no glycemic rescue therapy in this study.

Initial therapy with the combination of JANUVIA and pioglitazone provided significant improvements in A1C, FPG, and 2-hour PPG compared to pioglitazone monotherapy (Table 11). The improvement in A1C was generally consistent across subgroups defined by gender, age, race, baseline BMI, baseline A1C, or duration of disease. In this study, patients treated with JANUVIA in combination with pioglitazone had a mean increase in body weight of 1.1 kg compared to pioglitazone alone (3.0 kg vs. 1.9 kg). Lipid effects were generally neutral.

**Table 11:
Glycemic Parameters at Final Visit (24-Week Study)
for JANUVIA in Combination with Pioglitazone as Initial Therapy***

	JANUVIA 100 mg + Pioglitazone	Pioglitazone
A1C (%)	N = 251	N = 246
Baseline (mean)	9.5	9.4
Change from baseline (adjusted mean [†])	-2.4	-1.5
Difference from pioglitazone (adjusted mean [†]) (95% CI)	-0.9 [‡] (-1.1, -0.7)	
Patients (%) achieving A1C <7%	151 (60%)	68 (28%)
FPG (mg/dL)	N = 256	N = 253
Baseline (mean)	203	201
Change from baseline (adjusted mean [†])	-63	-40
Difference from pioglitazone (adjusted mean [†]) (95% CI)	-23 [‡] (-30, -15)	
2-hour PPG (mg/dL)	N = 216	N = 211
Baseline (mean)	283	284
Change from baseline (adjusted mean [†])	-114	-69
Difference from pioglitazone (adjusted mean [†]) (95% CI)	-45 [‡] (-57, -32)	

* Intent-to-treat population using last observation on study.

[†] Least squares means adjusted for baseline value.

[‡] p<0.001 compared to placebo + pioglitazone.

Add-on Combination Therapy with Metformin and Rosiglitazone

A total of 278 patients with type 2 diabetes participated in a 54-week, randomized, double-blind, placebo-controlled study designed to assess the efficacy of JANUVIA in combination with metformin and rosiglitazone. Patients on dual therapy with metformin ≥ 1500 mg/day and rosiglitazone ≥ 4 mg/day or with metformin ≥ 1500 mg/day and pioglitazone ≥ 30 mg/day (switched to rosiglitazone ≥ 4 mg/day) entered a dose-stable run-in period of 6 weeks. Patients on other dual therapy were switched to metformin ≥ 1500 mg/day and rosiglitazone ≥ 4 mg/day in a dose titration/stabilization run-in period of up to 20 weeks in duration. After the run-in period, patients with inadequate glycemic control (A1C 7.5% to 11%) were randomized 2:1 to the addition of either 100 mg of JANUVIA or placebo, administered once daily. Patients who failed to meet specific glycemic goals during the study were treated with glipizide (or other sulfonylurea) rescue. The primary time point for evaluation of glycemic parameters was Week 18.

In combination with metformin and rosiglitazone, JANUVIA provided significant improvements in A1C, FPG, and 2-hour PPG compared to placebo with metformin and rosiglitazone (Table 12) at Week 18. At Week 54, mean reduction in A1C was -1.0% for patients treated with JANUVIA and -0.3% for patients treated with placebo in an analysis based on the intent-to-treat population. Rescue therapy was used in 18% of patients treated with JANUVIA 100 mg and 40% of patients treated with placebo. There was no significant difference between JANUVIA and placebo in body weight change.

**Table 12:
Glycemic Parameters at Week 18
for JANUVIA in Add-on Combination Therapy with Metformin and Rosiglitazone***

	JANUVIA 100 mg + Metformin + Rosiglitazone	Placebo + Metformin + Rosiglitazone
A1C (%)	N = 176	N = 93
Baseline (mean)	8.8	8.7
Change from baseline (adjusted mean [†])	-1.0	-0.4
Difference from placebo + rosiglitazone + metformin (adjusted mean [†]) (95% CI)	-0.7 [‡] (-0.9, -0.4)	
Patients (%) achieving A1C <7%	39 (22%)	9 (10%)
FPG (mg/dL)	N = 179	N = 94
Baseline (mean)	181	182
Change from baseline (adjusted mean [†])	-30	-11
Difference from placebo + rosiglitazone + metformin (adjusted mean [†]) (95% CI)	-18 [‡] (-26, -10)	
2-hour PPG (mg/dL)	N = 152	N = 80
Baseline (mean)	256	248
Change from baseline (adjusted mean [†])	-59	-21
Difference from placebo + rosiglitazone + metformin (adjusted mean [†]) (95% CI)	-39 [‡] (-51, -26)	

* Intent-to-treat population using last observation on study prior to glipizide (or other sulfonylurea) rescue therapy.

[†] Least squares means adjusted for prior antihyperglycemic therapy status and baseline value.

[‡] p<0.001 compared to placebo + metformin + rosiglitazone.

Add-on Combination Therapy with Glimepiride, with or without Metformin

A total of 441 patients with type 2 diabetes participated in a 24-week, randomized, double-blind, placebo-controlled study designed to assess the efficacy of JANUVIA in combination with glimepiride, with or without metformin. Patients entered a run-in treatment period on glimepiride (≥4 mg per day) alone or glimepiride in combination with metformin (≥1500 mg per day). After a dose-titration and dose-stable run-in period of up to 16 weeks and a 2-week placebo run-in period, patients with inadequate glycemic control (A1C 7.5% to 10.5%) were randomized to the addition of either 100 mg of JANUVIA or placebo, administered once daily. Patients who failed to meet specific glycemic goals during the studies were treated with pioglitazone rescue.

In combination with glimepiride, with or without metformin, JANUVIA provided significant improvements in A1C and FPG compared to placebo (Table 13). In the entire study population (patients on JANUVIA in combination with glimepiride and patients on JANUVIA in combination with glimepiride and metformin), a mean reduction from baseline relative to placebo in A1C of -0.7% and in FPG of -20 mg/dL was seen. Rescue therapy was used in 12% of patients treated with JANUVIA 100 mg and 27% of patients treated with placebo. In this study, patients treated with JANUVIA had a mean increase in body weight of 1.1 kg vs. placebo (+0.8 kg vs. -0.4 kg). In addition, there was an increased rate of hypoglycemia. [See *Warnings and Precautions (5.4)*; *Adverse Reactions (6.1)*.]

Table 13:
Glycemic Parameters at Final Visit (24-Week Study)
for JANUVIA as Add-On Combination Therapy with Glimepiride, with or without Metformin*

	JANUVIA 100 mg + Glimepiride	Placebo + Glimepiride	JANUVIA 100 mg + Glimepiride + Metformin	Placebo + Glimepiride + Metformin
A1C (%)	N = 102	N = 103	N = 115	N = 105
Baseline (mean)	8.4	8.5	8.3	8.3
Change from baseline (adjusted mean [†])	-0.3	0.3	-0.6	0.3
Difference from placebo (adjusted mean [†]) (95% CI)	-0.6 [‡] (-0.8, -0.3)		-0.9 [‡] (-1.1, -0.7)	
Patients (%) achieving A1C <7%	11 (11%)	9 (9%)	26 (23%)	1 (1%)
FPG (mg/dL)	N = 104	N = 104	N = 115	N = 109
Baseline (mean)	183	185	179	179
Change from baseline (adjusted mean [†])	-1	18	-8	13
Difference from placebo (adjusted mean [†]) (95% CI)	-19 [§] (-32, -7)		-21 [‡] (-32, -10)	

* Intent-to-treat population using last observation on study prior to pioglitazone rescue therapy.

[†] Least squares means adjusted for prior antihyperglycemic therapy status and baseline value.

[‡] p<0.001 compared to placebo.

[§] p<0.01 compared to placebo.

Add-on Combination Therapy with Insulin (with or without Metformin)

A total of 641 patients with type 2 diabetes participated in a 24-week, randomized, double-blind, placebo-controlled study designed to assess the efficacy of JANUVIA as add-on to insulin therapy (with or without metformin). The racial distribution in this study was approximately 70% white, 18% Asian, 7% black, and 5% other groups. Approximately 14% of the patients in this study were Hispanic. Patients entered a 2-week, single-blind run-in treatment period on pre-mixed, long-acting, or intermediate-acting insulin, with or without metformin (≥1500 mg per day). Patients using short-acting insulins were excluded unless the short-acting insulin was administered as part of a pre-mixed insulin. After the run-in period, patients with inadequate glycemic control (A1C 7.5% to 11%) were randomized to the addition of either 100 mg of JANUVIA or placebo, administered once daily. Patients were on a stable dose of insulin prior to enrollment with no changes in insulin dose permitted during the run-in period. Patients who failed to meet specific glycemic goals during the double-blind treatment period were to have uptitration of the background insulin dose as rescue therapy.

The median daily insulin dose at baseline was 42 units in the patients treated with JANUVIA and 45 units in the placebo-treated patients. The median change from baseline in daily dose of insulin was zero for both groups at the end of the study. In combination with insulin (with or without metformin), JANUVIA provided significant improvements in A1C, FPG, and 2-hour PPG compared to placebo (Table 14). Both treatment groups had an adjusted mean increase in body weight of 0.1 kg from baseline to Week 24. There was an increased rate of hypoglycemia in patients treated with JANUVIA. [See *Warnings and Precautions (5.4); Adverse Reactions (6.1).*]

Table 14:
Glycemic Parameters at Final Visit (24-Week Study)
for JANUVIA as Add-on Combination Therapy with Insulin*

	JANUVIA 100 mg + Insulin (+/- Metformin)	Placebo + Insulin (+/- Metformin)
A1C (%)	N = 305	N = 312
Baseline (mean)	8.7	8.6
Change from baseline (adjusted mean [†])	-0.6	-0.1
Difference from placebo (adjusted mean ^{†,‡}) (95% CI)	-0.6 [§] (-0.7, -0.4)	
Patients (%) achieving A1C <7%	39 (12.8%)	16 (5.1%)
FPG (mg/dL)	N = 310	N = 313
Baseline (mean)	176	179
Change from baseline (adjusted mean [†])	-18	-4
Difference from placebo (adjusted mean [†]) (95% CI)	-15 [§] (-23, -7)	
2-hour PPG (mg/dL)	N = 240	N = 257
Baseline (mean)	291	292
Change from baseline (adjusted mean [†])	-31	5
Difference from placebo (adjusted mean [†]) (95% CI)	-36 [§] (-47, -25)	

* Intent-to-treat population using last observation on study prior to rescue therapy.

[†] Least squares means adjusted for metformin use at the screening visit (yes/no), type of insulin used at the screening visit (pre-mixed vs. non-pre-mixed [intermediate- or long-acting]), and baseline value.

[‡] Treatment by stratum interaction was not significant (p>0.10) for metformin stratum and for insulin stratum.

[§] p<0.001 compared to placebo.

Maintenance of JANUVIA During Initiation and Titration of Insulin Glargine

A total of 746 patients with type 2 diabetes (mean baseline HbA1C 8.8%, disease duration 10.8 years) participated in a 30-week, randomized, double-blind, placebo-controlled study to assess the efficacy and safety of continuing JANUVIA during the initiation and uptitration of insulin glargine. Patients who were on a stable dose of metformin (≥1500 mg/day) in combination with a DPP-4 inhibitor and/or sulfonylurea but with inadequate glycemic control (A1C 7.5% to 11%) were enrolled in the study. Those on metformin and JANUVIA (100 mg/day) directly entered the double-blind treatment period; those on another DPP-4 inhibitor and/or on a sulfonylurea entered a 4-8 week run-in period in which they were maintained on metformin and switched to JANUVIA (100 mg); other DPP-4 inhibitors and sulfonylureas were discontinued. At randomization patients were randomized either to continue JANUVIA or to discontinue JANUVIA and switch to a matching placebo. On the day of randomization, insulin glargine was initiated at a dose of 10 units subcutaneously in the evening. Patients were instructed to uptitrate their insulin dose in the evening based on fasting blood glucose measurements to achieve a target of 72-100 mg/dL.

At 30 weeks, the mean reduction in A1C was greater in the sitagliptin group than in the placebo group (Table 15). At the end of the trial, 27.3% of patients in the sitagliptin group and 27.3% in the placebo group had a fasting plasma glucose (FPG) in the target range; there was no significant difference in insulin dose between arms.

Table 15:
Change from Baseline in A1C and FPG at Week 30 in the Maintenance of JANUVIA During Initiation and Titration of Insulin Glargine Study

	Sitagliptin 100 mg +Metformin + Insulin Glargine	Placebo +Metformin + Insulin Glargine
A1C (%)	N = 373[†]	N = 370[†]
Baseline (mean)	8.8	8.8
Week 30 (mean)	6.9	7.3
Change from baseline (adjusted mean)*	-1.9	-1.4
Difference from placebo (adjusted mean) (95% CI)*	-0.4 (-0.6, -0.3) [‡]	
Patients (%) with A1C <7%	202 (54.2%)	131 (35.4%)
FPG (mg/dL)	N = 373[†]	N = 370[†]
Baseline (mean)	199	201
Week 30 (mean)	118	123
Change from baseline (adjusted mean)*	-81	-76

* Analysis of Covariance including all post-baseline data regardless of rescue or treatment discontinuation. Model estimates calculated using multiple imputation to model washout of the treatment effect using placebo data for all subjects having missing Week 30 data.

[†] N is the number of randomized and treated patients.

[‡] p<0.001 compared to placebo.

16 HOW SUPPLIED/STORAGE AND HANDLING

Tablets: JANUVIA, 25 mg, are pink, round, film-coated tablets with “221” on one side. They are supplied as follows:

NDC 0006-0221-31 unit-of-use bottles of 30

NDC 0006-0221-54 unit-of-use bottles of 90

NDC 0006-0221-28 unit dose blister packages of 100.

Tablets: JANUVIA, 50 mg, are light beige, round, film-coated tablets with “112” on one side. They are supplied as follows:

NDC 0006-0112-31 unit-of-use bottles of 30

NDC 0006-0112-54 unit-of-use bottles of 90

NDC 0006-0112-28 unit dose blister packages of 100.

Tablets: JANUVIA, 100 mg, are beige, round, film-coated tablets with “277” on one side. They are supplied as follows:

NDC 0006-0277-31 unit-of-use bottles of 30

NDC 0006-0277-54 unit-of-use bottles of 90

NDC 0006-0277-02 unit-of-use blister calendar package of 30

NDC 0006-0277-33 unit-of-use blister calendar package of 30

NDC 0006-0277-28 unit dose blister packages of 100

NDC 0006-0277-82 bottles of 1000.

Storage

Store at 20-25°C (68-77°F), excursions permitted to 15-30°C (59-86°F). [See USP Controlled Room Temperature.]

17 PATIENT COUNSELING INFORMATION

Advise the patient to read the FDA-approved patient labeling (Medication Guide).

Pancreatitis

Inform patients that acute pancreatitis has been reported during postmarketing use of JANUVIA. Inform patients that persistent severe abdominal pain, sometimes radiating to the back, which may or may not be accompanied by vomiting, is the hallmark symptom of acute pancreatitis. Instruct patients to

promptly discontinue JANUVIA and contact their physician if persistent severe abdominal pain occurs [see *Warnings and Precautions* (5.1)].

Heart Failure

Inform patients of the signs and symptoms of heart failure. Before initiating JANUVIA, ask patients about a history of heart failure or other risk factors for heart failure including moderate to severe renal impairment. Instruct patients to contact their health care provider as soon as possible if they experience symptoms of heart failure, including increasing shortness of breath, rapid increase in weight or swelling of the feet [see *Warnings and Precautions* (5.2)].

Hypoglycemia

Inform patients that the incidence of hypoglycemia is increased when JANUVIA is added to a sulfonylurea or insulin and that a lower dose of the sulfonylurea or insulin may be required to reduce the risk of hypoglycemia.

Hypersensitivity Reactions

Inform patients that allergic reactions have been reported during postmarketing use of JANUVIA. If symptoms of allergic reactions (including rash, hives, and swelling of the face, lips, tongue, and throat that may cause difficulty in breathing or swallowing) occur, patients must stop taking JANUVIA and seek medical advice promptly.

Severe and Disabling Arthralgia

Inform patients that severe and disabling joint pain may occur with this class of drugs. The time to onset of symptoms can range from one day to years. Instruct patients to seek medical advice if severe joint pain occurs [see *Warnings and Precautions* (5.6)].

Bullous Pemphigoid

Inform patients that bullous pemphigoid may occur with this class of drugs. Instruct patients to seek medical advice if blisters or erosions occur [see *Warnings and Precautions* (5.7)].

Distributed by: Merck Sharp & Dohme Corp., a subsidiary of
 **MERCK & CO., INC.**, Whitehouse Station, NJ 08889, USA

For patent information: www.merck.com/product/patent/home.html

Copyright © 2006-2019 Merck Sharp & Dohme Corp., a subsidiary of **Merck & Co., Inc.**
All rights reserved.

uspi-mk0431-t-1908r024

Medication Guide
JANUVIA® (jah-NEW-vee-ah)
(sitagliptin)
Tablets

Read this Medication Guide carefully before you start taking JANUVIA and each time you get a refill. There may be new information. This information does not take the place of talking with your doctor about your medical condition or your treatment. If you have any questions about JANUVIA, ask your doctor or pharmacist.

What is the most important information I should know about JANUVIA?

Serious side effects can happen in people taking JANUVIA, including:

- **Inflammation of the pancreas (pancreatitis) which may be severe and lead to death.** Certain medical problems make you more likely to get pancreatitis.

Before you start taking JANUVIA, tell your doctor if you have ever had:

- pancreatitis
- stones in your gallbladder (gallstones)
- a history of alcoholism
- high blood triglyceride levels
- kidney problems

Stop taking JANUVIA and call your doctor right away if you have pain in your stomach area (abdomen) that is severe and will not go away. The pain may be felt going from your abdomen through to your back. The pain may happen with or without vomiting. These may be symptoms of pancreatitis.

- **Heart failure.** Heart failure means your heart does not pump blood well enough.

Before you start taking JANUVIA, tell your doctor if you have ever had heart failure or have problems with your kidneys. Contact your doctor right away if you have any of the following symptoms:

- increasing shortness of breath or trouble breathing, especially when you lie down
- swelling or fluid retention, especially in the feet, ankles or legs
- an unusually fast increase in weight
- unusual tiredness

These may be symptoms of heart failure.

What is JANUVIA?

- JANUVIA is a prescription medicine used along with diet and exercise to lower blood sugar in adults with type 2 diabetes.
- JANUVIA is not for people with type 1 diabetes.
- JANUVIA is not for people with diabetic ketoacidosis (increased ketones in your blood or urine).
- If you have had pancreatitis (inflammation of the pancreas) in the past, it is not known if you have a higher chance of getting pancreatitis while you take JANUVIA.
- It is not known if JANUVIA is safe and effective when used in children under 18 years of age.

Who should not take JANUVIA?

Do not take JANUVIA if:

- you are allergic to any of the ingredients in JANUVIA. See the end of this Medication Guide for a complete list of ingredients in JANUVIA.

Symptoms of a serious allergic reaction to JANUVIA may include rash, raised red patches on your skin (hives), or swelling of the face, lips, tongue, and throat that may cause difficulty in breathing or swallowing.

What should I tell my doctor before taking JANUVIA?

Before you take JANUVIA, tell your doctor if you:

- have or have had inflammation of your pancreas (pancreatitis).
- have kidney problems.
- have any other medical conditions.
- are pregnant or plan to become pregnant. It is not known if JANUVIA will harm your unborn baby. If you are pregnant, talk with your doctor about the best way to control your blood sugar while you are pregnant.

Pregnancy Registry: If you take JANUVIA at any time during your pregnancy, talk with your doctor about how you can join the JANUVIA pregnancy registry. The purpose of this registry is to collect information about the health of you and your baby. You can enroll in this registry by calling 1-800-986-8999.

- are breast-feeding or plan to breast-feed. It is not known if JANUVIA will pass into your breast milk. Talk with your doctor about the best way to feed your baby if you are taking JANUVIA.

Tell your doctor about all the medicines you take, including prescription and over-the-counter medicines, vitamins, and herbal supplements.

Know the medicines you take. Keep a list of your medicines and show it to your doctor and pharmacist when you get a new medicine.

How should I take JANUVIA?

- Take JANUVIA 1 time each day exactly as your doctor tells you.
- You can take JANUVIA with or without food.
- Your doctor may do blood tests from time to time to see how well your kidneys are working. Your doctor may change your dose of JANUVIA based on the results of your blood tests.
- Your doctor may tell you to take JANUVIA along with other diabetes medicines. Low blood sugar can happen more often when JANUVIA is taken with certain other diabetes medicines. See **“What are the possible side effects of JANUVIA?”**.
- If you miss a dose, take it as soon as you remember. If you do not remember until it is time for your next dose, skip the missed dose and go back to your regular schedule. Do not take two doses of JANUVIA at the same time.
- If you take too much JANUVIA, call your doctor or local Poison Control Center right away.
- When your body is under some types of stress, such as fever, trauma (such as a car accident), infection or surgery, the amount of diabetes medicine that you need may change. Tell your doctor right away if you have any of these conditions and follow your doctor’s instructions.
- Check your blood sugar as your doctor tells you to.
- Stay on your prescribed diet and exercise program while taking JANUVIA.
- Talk to your doctor about how to prevent, recognize and manage low blood sugar (hypoglycemia), high blood sugar (hyperglycemia), and problems you have because of your diabetes.
- Your doctor will check your diabetes with regular blood tests, including your blood sugar levels and your hemoglobin A1C.

What are the possible side effects of JANUVIA?

Serious side effects have happened in people taking JANUVIA.

- See **“What is the most important information I should know about JANUVIA?”**.

- **Low blood sugar (hypoglycemia).** If you take JANUVIA with another medicine that can cause low blood sugar, such as a sulfonylurea or insulin, your risk of getting low blood sugar is higher. The dose of your sulfonylurea medicine or insulin may need to be lowered while you use JANUVIA. Signs and symptoms of low blood sugar may include:

- | | | | | |
|--------------|----------------|-------------|-------------------|-------------------|
| • headache | • irritability | • dizziness | • sweating | • weakness |
| • drowsiness | • hunger | • confusion | • feeling jittery | • fast heart beat |

- **Serious allergic reactions.** If you have any symptoms of a serious allergic reaction, stop taking JANUVIA and call your doctor right away. See **“Who should not take JANUVIA?”**. Your doctor may give you a medicine for your allergic reaction and prescribe a different medicine for your diabetes.

- **Kidney problems**, sometimes requiring dialysis

- **Joint pain.** Some people who take medicines called DPP-4 inhibitors like JANUVIA, may develop joint pain that can be severe. Call your doctor if you have severe joint pain.

- **Skin reaction.** Some people who take medicines called DPP-4 inhibitors like JANUVIA may develop a skin reaction called bullous pemphigoid that can require treatment in a hospital. Tell your doctor right away if you develop blisters or the breakdown of the outer layer of your skin (erosion). Your doctor may tell you to stop taking JANUVIA.

The most common side effects of JANUVIA include upper respiratory infection, stuffy or runny nose and sore throat, and headache.

JANUVIA may have other side effects, including stomach upset and diarrhea, swelling of the hands or legs, when JANUVIA is used with rosiglitazone (Avandia®). Rosiglitazone is another type of diabetes medicine.

These are not all the possible side effects of JANUVIA. For more information, ask your doctor or

pharmacist.

Tell your doctor if you have any side effect that bothers you, is unusual or does not go away.
Call your doctor for medical advice about side effects. You may report side effects to FDA at 1-800-FDA-1088.

How should I store JANUVIA?

Store JANUVIA at 68°F to 77°F (20°C to 25°C).

Keep JANUVIA and all medicines out of the reach of children.

General information about the use of JANUVIA

Medicines are sometimes prescribed for purposes that are not listed in Medication Guides. Do not use JANUVIA for a condition for which it was not prescribed. Do not give JANUVIA to other people, even if they have the same symptoms you have. It may harm them.

This Medication Guide summarizes the most important information about JANUVIA. If you would like to know more information, talk with your doctor. You can ask your doctor or pharmacist for additional information about JANUVIA that is written for health professionals. For more information, go to www.JANUVIA.com or call 1-800-622-4477.

What are the ingredients in JANUVIA?

Active ingredient: sitagliptin

Inactive ingredients: microcrystalline cellulose, anhydrous dibasic calcium phosphate, croscarmellose sodium, magnesium stearate, and sodium stearyl fumarate. The tablet film coating contains the following inactive ingredients: polyvinyl alcohol, polyethylene glycol, talc, titanium dioxide, red iron oxide, and yellow iron oxide.

What is type 2 diabetes?

Type 2 diabetes is a condition in which your body does not make enough insulin, and the insulin that your body produces does not work as well as it should. Your body can also make too much sugar. When this happens, sugar (glucose) builds up in the blood. This can lead to serious medical problems.

High blood sugar can be lowered by diet and exercise, and by certain medicines when necessary.

Distributed by: Merck Sharp & Dohme Corp., a subsidiary of

 **MERCK & CO., INC.**, Whitehouse Station, NJ 08889, USA

For patent information: www.merck.com/product/patent/home.html. The trademarks depicted herein are owned by their respective companies. Copyright © 2010-20XX Merck Sharp & Dohme Corp., a subsidiary of **Merck & Co., Inc.**

All rights reserved. usmg-mk0431-t-XXXXrXXX

This Medication Guide has been approved by the U.S. Food and Drug Administration.

Revised: XX/20XX

PRODUCT MONOGRAPH

PrLATUDA[®]

lurasidone hydrochloride

20 mg, 40 mg, 60 mg, 80 mg and 120 mg film-coated tablets

Antipsychotic

Sunovion Pharmaceuticals Canada Inc.
7025 Langer Drive, Suite 301
Mississauga, ON
Canada

Date of Preparation:
March 18, 2020

Submission Control No: **234629**

Table of Contents

PART I: HEALTH PROFESSIONAL INFORMATION.....3
SUMMARY PRODUCT INFORMATION3
INDICATIONS AND CLINICAL USE.....3
CONTRAINDICATIONS5
WARNINGS AND PRECAUTIONS.....5
ADVERSE REACTIONS.....18
DRUG INTERACTIONS50
DOSAGE AND ADMINISTRATION53
OVERDOSAGE56
ACTION AND CLINICAL PHARMACOLOGY56
STORAGE AND STABILITY59
SPECIAL HANDLING INSTRUCTIONS59
DOSAGE FORMS, COMPOSITION AND PACKAGING59

PART II: SCIENTIFIC INFORMATION60
PHARMACEUTICAL INFORMATION.....60
CLINICAL TRIALS.....61
DETAILED PHARMACOLOGY65
TOXICOLOGY67

PART III: CONSUMER INFORMATION.....73

LATUDA®

lurasidone hydrochloride

PART I: HEALTH PROFESSIONAL INFORMATION

SUMMARY PRODUCT INFORMATION

Route of Administration	Dosage Form / Strength	Nonmedicinal Ingredients
Oral	Film-Coated Tablets / 20 mg, 40 mg, 60 mg, 80 mg, and 120 mg	Carnauba wax, croscarmellose sodium, hypromellose, magnesium stearate, mannitol, Opadry® (hypromellose, polyethylene glycol, and titanium dioxide), pregelatinized starch; 80 mg tablet also contains: FD&C Blue No.2 Aluminum Lake and yellow ferric oxide.

INDICATIONS AND CLINICAL USE

Adults

Schizophrenia

LATUDA (lurasidone HCl) is indicated for the management of the manifestations of schizophrenia.

The antipsychotic efficacy of LATUDA was established in short-term (6-week) controlled trials [see **CLINICAL TRIALS**]. The efficacy of LATUDA in long-term use, that is, for more than 6 weeks, has not been systematically evaluated in controlled trials of patients with manifestations of schizophrenia.

Depressive Episodes Associated with Bipolar I Disorder

LATUDA is indicated as monotherapy or as adjunctive therapy with lithium or valproate for the acute management of depressive episodes associated with bipolar I disorder.

The efficacy of LATUDA for long-term use, that is, for more than 6 weeks, has not been systematically evaluated in controlled studies. The physician who elects to use LATUDA for extended periods should periodically re-evaluate the long term usefulness of the drug for the individual patient.

Geriatrics (>65 years of age):

LATUDA is not indicated in elderly patients with dementia [see **WARNINGS AND PRECAUTIONS, Serious Warnings and Precautions Box** and **Special Populations**]. The safety and efficacy of LATUDA in patients 65 years of age or older has not been established.

Pediatrics (<18 years of age)

When prescribing to adolescents with schizophrenia or adolescents with depressive episodes associated with bipolar I disorder, clinicians must take into account the safety concerns associated with all antipsychotic drugs which include: extrapyramidal effects, hyperglycemia, weight gain, and hyperlipidemia, which can be more frequent or more severe in this patient population than in adults [see **WARNINGS AND PRECAUTIONS** and **ADVERSE REACTIONS**]. LATUDA should only be prescribed to adolescents with schizophrenia or bipolar I disorder by clinicians who are experienced in the diagnosis and treatment of adolescents with psychiatric illness and who are experienced in the early detection and management of the above-mentioned safety issues associated with this class of drugs.

Schizophrenia

LATUDA is indicated for the management of the manifestations of schizophrenia in adolescents (15-17 years).

The safety and efficacy of LATUDA was evaluated in one short-term (6 week) controlled trial in adolescents (13-17 years) [see **CLINICAL TRIALS**]. LATUDA is not indicated for the treatment of schizophrenia in adolescents less than 15 years of age due to insufficient safety and efficacy data [see **ADVERSE REACTIONS, CLINICAL TRIALS, Schizophrenia, Adolescents**].

The efficacy of LATUDA in long-term use, that is, for more than 6 weeks, has not been systematically evaluated in controlled trials of patients with manifestations of schizophrenia. The physician who elects to use LATUDA for extended periods in adolescents with manifestations of schizophrenia should periodically re-evaluate the long term usefulness of the drug for the individual patient. The safety and efficacy of LATUDA in schizophrenia patients less than 13 years of age has not been evaluated.

Depressive Episodes Associated with Bipolar I Disorder

LATUDA is indicated as monotherapy for the acute management of depressive episodes associated with bipolar I disorder in adolescent (13 to 17 years) patients.

The safety and efficacy of LATUDA 20 to 80 mg/day for the treatment of bipolar depression in children and adolescents (10 to 17 years) was evaluated in a 6-week, placebo-controlled clinical study in 343 children and adolescents. LATUDA is not indicated for the treatment of depressive episodes in bipolar I disorder in patients less than 13 years of age due to insufficient safety and efficacy data [see **ADVERSE REACTIONS, DOSAGE AND ADMINISTRATION** and **CLINICAL TRIALS**].

CONTRAINDICATIONS

LATUDA (lurasidone HCl) is contraindicated in any patient with a known hypersensitivity to lurasidone HCl or any components in the formulation [for a complete listing, see **DOSAGE FORMS, COMPOSITION AND PACKAGING**]. Angioedema has been observed with lurasidone [see **ADVERSE REACTIONS**].

LATUDA is contraindicated with strong CYP3A4 inhibitors (e.g., ketoconazole) and strong CYP3A4 inducers (e.g., rifampin) [see **DRUG INTERACTIONS**].

WARNINGS AND PRECAUTIONS

Serious Warnings and Precautions

Increased Mortality in Elderly Patients with Dementia.

Elderly patients with dementia treated with atypical antipsychotic drugs are at an increased risk of death compared to placebo. Analyses of thirteen placebo-controlled trials with various atypical antipsychotics (modal duration of 10 weeks) in these patients showed a mean 1.6-fold increase in the death rate in the drug-treated patients. Although the causes of death were varied, most of the deaths appeared to be either cardiovascular (e.g., heart failure, sudden death) or infectious (e.g., pneumonia) in nature [see **WARNINGS AND PRECAUTIONS, Special Populations, Use in Elderly Patients with Dementia**].

General

Body Temperature Regulation

Disruption of the body's ability to reduce core body temperature has been attributed to antipsychotic agents. Appropriate care is advised when prescribing LATUDA (lurasidone HCl) for patients who will be experiencing conditions that may contribute to an elevation in core body temperature, e.g., exercising strenuously, exposure to extreme heat, receiving concomitant medication with anticholinergic activity, or being subject to dehydration.

Carcinogenesis and Mutagenesis

For animal data, see **TOXICOLOGY**.

Cardiovascular

Orthostatic Hypotension and Syncope

LATUDA may cause orthostatic hypotension, perhaps due to its α 1-adrenergic receptor antagonism.

LATUDA should be used with caution in elderly patients and patients with known cardiovascular disease (e.g., heart failure, history of myocardial infarction, ischemia, or conduction abnormalities), cerebrovascular disease, or conditions that predispose the patient to hypotension (e.g., dehydration, hypovolemia, and treatment with antihypertensive medications). Monitoring of orthostatic vital signs should be considered in patients who are vulnerable to hypotension.

Assessment of orthostatic hypotension was defined by vital sign changes (≥ 20 mmHg decrease in systolic blood pressure and ≥ 10 bpm increase in pulse from sitting to standing or supine to standing positions).

Schizophrenia

Adults

The incidence of orthostatic hypotension and syncope reported as adverse events from short-term, placebo-controlled schizophrenia studies was (LATUDA incidence; placebo incidence): orthostatic hypotension (5/1508 or 0.3% LATUDA; 1/708 or 0.1% placebo) and syncope (2/1508 or 0.1% LATUDA; 0/708 or 0% placebo). In short-term clinical trials orthostatic hypotension, as assessed by vital signs and occurring at any post-baseline assessment, occurred with a frequency of 4.2% with LATUDA 40 mg, 3.3% with LATUDA 80 mg, 3.7% with LATUDA 120 mg, and 2.5% with LATUDA 160 mg compared to 1.6% with placebo.

Adolescents

The incidence of orthostatic hypotension reported as adverse events from the short-term (6 week), placebo-controlled adolescent schizophrenia study was 0.5% (1/214) in LATUDA-treated patients and 0% (0/112) with placebo. No syncope event was reported. Orthostatic hypotension, as assessed by vital signs, occurred with a frequency of 0% with LATUDA 40 mg and 2.9% with LATUDA 80 mg, compared to 1.8% with placebo.

Bipolar Depression

Adults

Monotherapy

In the short-term, placebo-controlled monotherapy study, there were no reported adverse events of orthostatic hypotension or syncope. Orthostatic hypotension, as assessed by vital signs and occurring at any post-baseline assessment, occurred with a frequency of 6.8% in the LATUDA 20-60 mg and 4.3% in the LATUDA 80-120 mg flexible-dose groups compared to 1.2% with placebo.

Adjunctive Therapy

In the short-term, flexible-dose, placebo-controlled adjunctive therapy studies, there were no reported adverse events of orthostatic hypotension or syncope. Orthostatic hypotension, as assessed by vital signs and occurring at any post-baseline assessment, occurred with a frequency of 4.5% with LATUDA 20-120 mg compared to 4.9% with placebo.

Children and Adolescents

No incidences of orthostatic hypotension were reported as adverse events from the children and adolescents short-term, placebo-controlled bipolar depression study. No syncope event was reported in LATUDA-treated subjects. Orthostatic hypotension, as assessed by vital signs and occurring at any post-baseline assessment, occurred with a frequency of 1.1% with LATUDA 20 to 80 mg/day, compared to 0.6% with placebo.

QT Interval

Thorough QT Study: The effects of LATUDA on the QT/QTc interval were evaluated in a dedicated QT study. The trial involved LATUDA doses of 120 and 600 mg once daily and ziprasidone (80 mg twice daily) as a positive control. The study was conducted in 87 clinically stable patients with schizophrenia. ECG data were collected over an 8 hour time period on the baseline day (Day 0) and on Day 11 of the double-blind treatment period. Statistically significant increases from baseline in the QTcF (N=63) interval were observed from 1 to 8 hour post-dosing with lurasidone 120 mg, lurasidone 600 mg, and ziprasidone 160 mg. The maximum mean increases in QTcF from baseline were 11.6 msec for lurasidone 120 mg (N=22), 9.9 msec for lurasidone 600 mg (N=18), and 21.1 msec for ziprasidone (N=23). There was no apparent dose (exposure)-response relationship in this study. No patients treated with LATUDA experienced QTc increases ≥ 60 msec from baseline, or a QTc of ≥ 500 msec.

Phase 2/3 clinical studies: In the short-term, placebo-controlled trials, a single 12-lead ECG was recorded at screening, at baseline in most studies, and at one or more days during the double-blind period, at either pre-dose or at a single post-dosing time point. In the short-term, placebo-controlled trials, no post-baseline QTc prolongations exceeding 500 msec were reported in patients treated with LATUDA or placebo, or any of the active comparators.

The use of LATUDA should be avoided in combination with drugs known to prolong QTc including Class 1A antiarrhythmics (e.g., quinidine, procainamide) or Class 3 antiarrhythmics (e.g., amiodarone, sotalol), antipsychotic medications (e.g., ziprasidone, chlorpromazine, thioridazine), and antibiotics (e.g., gatifloxacin, moxifloxacin). LATUDA should also be avoided in patients with a history of cardiac arrhythmias and in other circumstances that may increase the risk of the occurrence of torsade de pointes and/or sudden death in association with the use of drugs that prolong the QTc interval, including bradycardia, hypokalemia, or hypomagnesemia; and presence of congenital prolongation of the QT interval.

Venous Thromboembolism

See also **WARNINGS AND PRECAUTIONS, Hematologic, Venous Thromboembolism.**

Dependence/Tolerance

LATUDA has not been systematically studied in humans for its potential for abuse or physical dependence or its ability to induce tolerance. While clinical studies with LATUDA did not reveal any tendency for drug-seeking behaviour, these observations were not systematic and it is not possible to predict the extent to which a CNS-active drug will be misused, diverted, and/or abused once it is marketed. Patients should be evaluated carefully for a history of drug abuse, and such patients should be observed carefully for signs of LATUDA misuse or abuse (e.g., development

of tolerance, drug-seeking behaviour, increases in dose).

Endocrine and Metabolism

Hyperglycemia and Diabetes Mellitus [see ADVERSE REACTIONS]

Hyperglycemia, in some cases extreme and associated with ketoacidosis or hyperosmolar coma or death, has been reported in patients treated with atypical antipsychotics. These cases were, for the most part, seen in post-marketing clinical use and epidemiologic studies, and not in clinical trials. Diabetic ketoacidosis (DKA) has occurred in patients treated with antipsychotics with no reported history of hyperglycemia.

In clinical trials, hyperglycemia or exacerbation of pre-existing diabetes has occasionally been reported during treatment with LATUDA.

Assessment of the relationship between atypical antipsychotic use and glucose abnormalities is complicated by the possibility of an increased background risk of diabetes mellitus in patients with schizophrenia and the increasing incidence of diabetes mellitus in the general population. Given these confounders, the relationship between atypical antipsychotic use and hyperglycemia-related adverse events is not completely understood. However, epidemiological studies, which did not include LATUDA, suggest an increased risk of treatment-emergent hyperglycemia-related adverse events in patients treated with the atypical antipsychotics. Because LATUDA was not marketed at the time these studies were performed, it is not known if LATUDA is associated with this increased risk. Precise risk estimates for hyperglycemia-related adverse events in patients treated with atypical antipsychotics are not available.

Patients should have baseline and periodic monitoring of blood glucose and body weight. Any patient treated with atypical antipsychotics should be monitored for symptoms of hyperglycemia including polydipsia, polyuria, polyphagia, and weakness. Patients who develop symptoms of hyperglycemia during treatment with atypical antipsychotics should undergo fasting blood glucose testing. In some cases, hyperglycemia has resolved when the atypical antipsychotic was discontinued; however, some patients required continuation of anti-diabetic treatment despite discontinuation of the suspect drug. Patients with risk factors for diabetes mellitus (e.g., obesity, family history of diabetes) who are starting treatment with atypical antipsychotics should undergo fasting blood glucose testing at the beginning of treatment and periodically during treatment. Patients with an established diagnosis of diabetes mellitus who are started on atypical antipsychotics should be monitored regularly for worsening of glucose control.

Hyperprolactinemia

As with other drugs that antagonize dopamine D₂ receptors, LATUDA can elevate prolactin levels [see ADVERSE REACTIONS].

Hyperprolactinemia may suppress hypothalamic GnRH, resulting in reduced pituitary gonadotrophin secretion. This, in turn, may inhibit reproductive function by impairing gonadal steroidogenesis in both female and male patients. Galactorrhea, amenorrhea, gynecomastia, and impotence have been reported with prolactin-elevating compounds. Long-standing hyperprolactinemia when associated with hypogonadism may lead to decreased bone mineral

density in both female and male patients.

Tissue culture experiments indicate that approximately one-third of human breast cancers are prolactin dependent *in vitro*, a factor of potential importance if the prescription of these drugs is considered in a patient with previously detected breast cancer. As is common with compounds which increase prolactin release, an increase in mammary gland neoplasia was observed in a LATUDA carcinogenicity study conducted in rats and mice [see **TOXICOLOGY**]. The physiological differences between rats and humans with regard to prolactin make the clinical significance of these findings unclear. To date, neither clinical nor epidemiological studies have shown an association between chronic administration of these drugs and mammary tumorigenesis.

Schizophrenia

Adults

In short-term, placebo-controlled trials in patients with schizophrenia, the proportion of patients with prolactin elevations $\geq 5X$ ULN was 2.8% for LATUDA-treated patients versus 1.0% for placebo-treated patients. The proportion of female patients with prolactin elevations $\geq 5X$ ULN was 5.7% for LATUDA-treated patients versus 2.0% for placebo-treated female patients. The proportion of male patients with prolactin elevations $\geq 5X$ ULN was 1.6% versus 0.6% for placebo-treated male patients.

Adolescents

The proportion of patients with prolactin elevations $\geq 5X$ ULN was 0.5% for LATUDA-treated patients (1.0% for 40 mg and 0% for 80 mg dose) versus 1.0% for placebo-treated patients. The proportion of female patients with prolactin elevations $\geq 5X$ ULN was 1.3% for LATUDA-treated patients (2.4% for 40 mg and 0% for 80 mg dose) versus 0% for placebo-treated female patients. The proportion of male patients with prolactin elevations $\geq 5X$ ULN was 0% for LATUDA-treated patients versus 1.6% for placebo-treated male patients.

Bipolar Depression

Adults

Monotherapy

In the short-term, placebo-controlled monotherapy study, the proportion of patients with prolactin elevations $\geq 5X$ ULN was 0.4% for LATUDA-treated patients versus 0.0% for placebo-treated patients. The proportion of female patients with prolactin elevations $\geq 5X$ ULN was 0.6% for LATUDA-treated patients versus 0% for placebo-treated female patients. There were no prolactin elevations $\geq 5X$ ULN in male patients.

Adjunctive Therapy

In the short-term, flexible-dose, placebo-controlled adjunctive therapy studies, there were no patients with prolactin elevations $\geq 5X$ ULN.

Children and Adolescents

In the children and adolescents short-term, placebo-controlled bipolar depression study, the proportion of patients with prolactin elevations $\geq 5X$ ULN was 0% for LATUDA-treated patients versus 0.6% for placebo-treated patients. The proportion of female patients with prolactin elevations $\geq 5X$ ULN was 0% for LATUDA-treated patients versus 1.3% for placebo-treated female patients. The proportion of male patients with prolactin elevations $\geq 5X$ ULN was 0% for LATUDA-treated patients versus 0% for placebo-treated male patients.

The median change from baseline to endpoint in prolactin levels for LATUDA-treated patients was +1.10 ng/mL and was +0.50 ng/mL for placebo-treated patients. For LATUDA-treated patients, the median change from baseline to endpoint for males was +0.85 ng/mL and for females was +2.50 ng/mL [See **ADVERSE REACTIONS, Abnormal Hematologic and Clinical Chemistry Findings, Hyperprolactinemia**].

Weight Gain

Schizophrenia

Adults

In pooled short-term (6-week) clinical trials, the mean change in weight was a 0.43 kg increase for LATUDA-treated patients compared to a 0.02 kg decrease for placebo-treated patients. The proportion of patients with a $\geq 7\%$ increase in body weight (at Endpoint) was 4.8% for LATUDA-treated patients versus 3.3% for placebo-treated patients.

Adolescents

In the short-term (6 week), placebo-controlled adolescent schizophrenia study, the mean weight gain was 0.5 kg for LATUDA-treated patients (0.3 kg for 40 mg and 0.7 kg for 80 mg dose) compared to 0.2 kg for placebo-treated patients. The proportion of patients with a $\geq 7\%$ increase in body weight (at Endpoint) was 2.3% for LATUDA-treated patients (2.8% for 40 mg and 1.9% for 80 mg dose) versus 4.5% for placebo-treated patients.

Bipolar Depression

Adults

Monotherapy

In the short-term, placebo-controlled monotherapy study, the mean weight gain was 0.29 kg for LATUDA-treated patients compared to -0.04 kg for placebo-treated patients. The proportion of patients with a $\geq 7\%$ increase in body weight (at Endpoint) was 2.4% for LATUDA-treated patients versus 0.7% for placebo-treated patients.

Adjunctive Therapy

In the short-term, flexible-dose, placebo-controlled adjunctive therapy studies, the mean weight gain was 0.11 kg for LATUDA-treated patients compared to 0.16 kg for placebo-treated patients. The proportion of patients with a $\geq 7\%$ increase in body weight (at Endpoint) was 3.1% for LATUDA-treated patients versus 0.3% for placebo-treated patients.

Children and Adolescents

In the children and adolescents short-term, placebo-controlled bipolar depression study, 7% of LATUDA-treated patients reported weight gain as an adverse event compared to 2% of placebo-treated patients. The mean weight gain was 0.7 kg for LATUDA-treated patients compared to 0.5 kg for placebo-treated patients. The proportion of patients with a $\geq 7\%$ increase in body weight (at Endpoint) was 4.0% for LATUDA-treated patients versus 5.3% for placebo-treated patients.

Gastrointestinal

Antiemetic Effect

Drugs that have dopamine antagonist effects may have an antiemetic effect. Such an effect may mask signs of toxicity due to overdosage of other drugs, or may mask symptoms of disease such as brain tumour or intestinal obstruction.

Genitourinary

Rare cases of priapism have been reported with antipsychotic use, such as LATUDA. This adverse reaction is generally not found to be dose-dependent or correlated with the duration of treatment.

Hematologic

Leukopenia, Neutropenia, and Agranulocytosis

Neutropenia, granulocytopenia, and agranulocytosis have been reported during antipsychotic use. Therefore, it is recommended that patients have their complete blood count (CBC) tested prior to starting LATUDA and then periodically throughout treatment.

Possible risk factors for leukopenia/neutropenia include pre-existing low white blood cell count (WBC) and history of drug induced leukopenia/neutropenia. Patients with a pre-existing low WBC or a history of drug induced leukopenia/neutropenia should have their complete blood count (CBC) monitored frequently during the first few months of therapy and LATUDA should be discontinued at the first sign of decline in WBC, in the absence of other causative factors. Patients with neutropenia should be carefully monitored for fever or other symptoms or signs of infection and treated promptly if such symptoms or signs occur. Patients with severe neutropenia (absolute neutrophil count $<1 \times 10^9/L$) should discontinue LATUDA and have their WBC followed until recovery.

Venous Thromboembolism

Venous thromboembolism (VTE), including fatal pulmonary embolism, has been reported with antipsychotic drugs, including LATUDA, in case reports and/or observational studies. When prescribing LATUDA all potential risk factors for VTE should be identified and preventative measures undertaken.

Hepatic

See **WARNINGS AND PRECAUTIONS**, **Special Populations**, **Use in Patients with Hepatic Impairment**, **DOSAGE AND ADMINISTRATION** and **ACTION AND CLINICAL PHARMACOLOGY**.

Immune

Drug Reaction with Eosinophilia and Systemic Symptoms (DRESS)

Post market cases of DRESS have been reported in association with similar atypical antipsychotic drugs within the class.

Neurologic

Neuroleptic Malignant Syndrome

A potentially fatal symptom complex sometimes referred to as Neuroleptic Malignant Syndrome (NMS) has been reported in association with administration of antipsychotic drugs, including LATUDA [see **ADVERSE REACTIONS**].

Clinical manifestations of NMS are hyperpyrexia, muscle rigidity, altered mental status, and evidence of autonomic instability (irregular pulse or blood pressure, tachycardia, diaphoresis, and cardiac dysrhythmia). Additional signs may include elevated creatine phosphokinase, myoglobinuria (rhabdomyolysis), and acute renal failure.

In arriving at a diagnosis, it is important to identify cases where the clinical presentation includes both serious medical illness (e.g., pneumonia, systemic infection) and untreated or inadequately treated extrapyramidal signs and symptoms (EPS). Other important considerations in the differential diagnosis include central anticholinergic toxicity, heat stroke, drug fever, and primary central nervous system pathology.

The management of NMS should include: 1) immediate discontinuation of all antipsychotic drugs, including LATUDA, and other drugs not essential to concurrent therapy; 2) intensive symptomatic treatment and medical monitoring; and 3) treatment of any concomitant serious medical problems for which specific treatments are available. There is no general agreement about specific pharmacological treatment regimens for uncomplicated NMS.

If a patient requires antipsychotic drug treatment after recovery from NMS, the potential reintroduction of drug therapy should be carefully considered. The patient should be carefully monitored, since recurrences of NMS have been reported.

Tardive Dyskinesia [see **ADVERSE REACTIONS]**

Tardive dyskinesia, a syndrome consisting of potentially irreversible, involuntary, dyskinetic movements, may develop in patients treated with antipsychotic drugs. Although the prevalence of the syndrome appears to be highest among the elderly, especially elderly women, it is impossible to rely upon prevalence estimates to predict, at the inception of antipsychotic treatment, which patients are likely to develop the syndrome. Whether antipsychotic drug products differ in their

potential to cause tardive dyskinesia is unknown.

The risk of developing tardive dyskinesia and the likelihood that it will become irreversible are believed to increase as the duration of treatment and the total cumulative dose of antipsychotic drugs administered to the patient increase. However, the syndrome can develop, although much less commonly, after relatively brief treatment periods at low doses.

There is no known treatment for established cases of tardive dyskinesia, although the syndrome may remit, partially or completely, if antipsychotic treatment is withdrawn. Antipsychotic treatment, itself, however, may suppress (or partially suppress) the signs and symptoms of the syndrome and thereby may possibly mask the underlying process. The effect that symptomatic suppression has upon the long-term course of the syndrome is unknown.

Given these considerations, LATUDA should be prescribed in a manner that is most likely to minimize the occurrence of tardive dyskinesia. Chronic antipsychotic treatment should generally be reserved for patients who suffer from a chronic illness that 1) is known to respond to antipsychotic drugs, and 2) for whom alternative, equally effective, but potentially less harmful treatments are not available or appropriate. In patients who do require chronic treatment, the smallest dose and the shortest duration of treatment producing a satisfactory clinical response should be sought. The need for continued treatment should be reassessed periodically.

If signs and symptoms of tardive dyskinesia appear in a patient on LATUDA, drug discontinuation should be considered. However, some patients may require treatment with LATUDA despite the presence of the syndrome.

Seizures

As with other antipsychotic drugs, LATUDA should be used cautiously in patients with a history of seizures or with conditions that lower the seizure threshold, e.g., Alzheimer's dementia [see **ADVERSE REACTIONS**]. Conditions that lower the seizure threshold may be more prevalent in patients 65 years or older.

Potential for Cognitive and Motor Impairment

LATUDA, like other antipsychotics, has the potential to impair judgement, thinking, or motor skills [see **ADVERSE REACTIONS**]. Somnolence is a commonly reported adverse event in patients treated with LATUDA.

Patients should be cautioned about operating hazardous machinery, including motor vehicles, until they are reasonably certain that therapy with LATUDA does not affect them adversely.

Schizophrenia

Adults

In short-term, placebo-controlled schizophrenia studies, somnolence was reported in 17% of patients treated with LATUDA doses from 20 mg to 160 mg/day.

Adolescents

In a short-term (6 week), placebo-controlled adolescent schizophrenia study, somnolence was reported by 14.5% (31/214) of patients treated with LATUDA (15.5% LATUDA 40 mg and 13.5% LATUDA 80 mg/day) compared to 7.1% (8/112) of placebo patients.

Bipolar Depression

Adults

Monotherapy

In the short-term, placebo-controlled monotherapy study, somnolence was reported by 7.3% (12/164) and 13.8% (23/167) of patients in the LATUDA 20-60 mg and LATUDA 80-120 mg flexible-dose groups, respectively, compared to 6.5% (11/168) of placebo patients.

Adjunctive Therapy

In the short-term, flexible-dose, placebo-controlled adjunctive therapy studies, somnolence was reported by 11.4% (41/360) of patients treated with LATUDA 20-120 mg compared to 5.1% (17/334) of placebo patients.

Children and Adolescents

In the children and adolescents short-term, placebo-controlled bipolar depression study, somnolence was reported by 11.4% (20/175) of patients treated with LATUDA 20 to 80 mg/day compared to 5.8% (10/172) of placebo-treated patients.

Falls

LATUDA may cause somnolence, postural hypotension, motor and sensory instability, which may lead to falls and, consequently, fractures or other injuries. For patients with diseases, conditions, or medications that could exacerbate these effects, complete fall risk assessments when initiating antipsychotic treatment and recurrently for patients on long-term antipsychotic therapy.

Psychiatric

Suicide [see **ADVERSE REACTIONS**]

Suicide/suicidal thoughts or clinical worsening: Depressive episodes are associated with an increased risk of suicidal thoughts, self-harm and suicide (suicide-related events). This risk persists until significant remission of depression occurs. As improvement may not occur during the first few weeks or more of treatment, patients should be closely monitored until such improvement occurs. It is general clinical experience that the risk of suicide may increase in the early stages of recovery. In addition to depressive episodes associated with bipolar disorder, depression may be co-morbid with schizophrenia.

Schizophrenia is also associated with an increased risk of suicide-related events, and thus close supervision and appropriate clinical management of high risk patients should accompany drug therapy.

In a short-term (6 week), placebo-controlled adolescent schizophrenia study, the incidence of treatment-emergent suicidal ideation was 3.3% (7/213) for LATUDA-treated patients compared to 4.5% (5/112) on placebo. No suicide attempts or completed suicides were reported in this study.

Patients with a history of suicide-related events are also known to be at a greater risk of suicidal thoughts or suicide attempts, and should receive careful monitoring during treatment.

Prescriptions for LATUDA should be written for the smallest quantity of tablets consistent with good patient management in order to reduce the risk of overdose.

Renal

See **WARNINGS AND PRECAUTIONS, Special Populations, Use in Patients with Renal Impairment, DOSAGE AND ADMINISTRATION** and **ACTION AND CLINICAL PHARMACOLOGY**.

Special Populations

Pregnant Women

Teratogenic Effects: There are no adequate and well-controlled studies of LATUDA in pregnant woman. Lurasidone was not teratogenic in rats and rabbits [see also **TOXICOLOGY, Reproductive and Developmental Toxicity**].

Non-Teratogenic Effects: Neonates exposed to antipsychotic drugs during the third trimester of pregnancy are at risk for extrapyramidal and/or withdrawal symptoms following delivery. There have been reports of agitation, hypertonia, hypotonia, tremor, somnolence, respiratory distress, and feeding disorder in these neonates. These complications have varied in severity; while in some cases symptoms have been self-limited, in other cases neonates have required intensive care unit support and prolonged hospitalization.

Patients should be advised to notify their physician if they become pregnant or intend to become pregnant during treatment with LATUDA. LATUDA should be used during pregnancy only if the potential benefit justifies the potential risk to the fetus.

Labour and Delivery

The effect of LATUDA on labour and delivery in humans is unknown.

Nursing Women

LATUDA was excreted in milk of rats during lactation. It is not known whether LATUDA or its metabolites are excreted in human milk. It is recommended that women receiving LATUDA should not breast-feed.

Pediatrics (<18 years of age)

When prescribing to adolescents with schizophrenia (15-17 years of age) or adolescents with depressive episodes associated with bipolar I disorder (13 -17 years of age), clinicians must take into account the safety concerns associated with all antipsychotic drugs which include:

extrapyramidal effects, hyperglycemia, weight gain, and hyperlipidemia, which can be more frequent or more severe in this patient population than in adults [see **WARNINGS AND PRECAUTIONS** and **ADVERSE REACTIONS**]. LATUDA should only be prescribed to adolescents with schizophrenia or bipolar I disorder by clinicians who are experienced in the diagnosis and treatment of adolescents with psychiatric illness and who are experienced in the early detection and management of the above-mentioned safety issues associated with this class of drugs.

Weight gain has been observed with atypical antipsychotic use in pediatric and adolescent patient populations. Independent of any drug-specific effects, weight gain can be associated with adverse changes in other metabolic parameters (e.g., glucose and lipid metabolism).

Abnormal childhood weight and metabolic status can have adverse effects on cardiovascular outcomes in adulthood. Weight gain and adverse effects on other metabolic parameters associated with atypical antipsychotics can be more frequent or more severe in pediatric and adolescent patients than in the adult patients.

The long-term safety, including cardiometabolic effects and effects on growth, maturation and behavioural development in patients under 18 years of age has not been systematically evaluated.

Schizophrenia

The safety and efficacy of LATUDA in the treatment of manifestations of schizophrenia in adolescents (15 to 17 years) were established in a 6-week, placebo-controlled clinical study in 326 adolescent patients [see **DOSAGE AND ADMINISTRATION**, **ADVERSE REACTIONS**, and **CLINICAL TRIALS**].

The following adverse events reported in the study in adolescents with schizophrenia were reported at a greater incidence rate compared to the adult schizophrenia studies, or with a greater differential over placebo: Nausea (differential over placebo 10.9% for all doses in adolescents versus 5% average for all doses in adult studies), vomiting (differential over placebo 5.7% for all doses in adolescents versus 2% average for all doses in adult studies), dizziness (differential over placebo 3.8% for all doses in adolescents versus 2% average for all doses in adult studies), and diarrhea (differential over placebo 1.8% for all doses in adolescents; all cases resolved within a few days without dose adjustment or discontinuation) [see **ADVERSE REACTIONS**].

Irritability Associated with Autistic Disorder

Efficacy was not demonstrated in a 6-week study evaluating LATUDA 20 mg/day and 60 mg/day for the treatment of pediatric patients 6 to 17 years of age with irritability associated with autistic disorder.

Bipolar Depression

The safety and efficacy of LATUDA 20 to 80 mg/day for the treatment of bipolar depression in adolescents (13 to 17 years) was established in a 6-week, placebo-controlled clinical study in 343 children and adolescents (10-17 years). LATUDA is not indicated for the treatment of depressive episodes in bipolar I disorder in patients less than 13 years of age due to insufficient safety and efficacy data [see **ADVERSE REACTIONS**, **DOSAGE AND ADMINISTRATION** and

CLINICAL TRIALS].

The following adverse events reported in the study in children and adolescents with bipolar depression were reported at a greater incidence rate compared to the adult bipolar monotherapy studies, or with a greater differential over placebo: Nausea (differential over placebo 10.2% in children and adolescents versus 6.2% average for all doses in adult monotherapy studies), vomiting (differential over placebo 2.8% in children and adolescents versus 2.4% average for all doses in adult monotherapy studies), somnolence (differential over placebo 5.6% in children and adolescents versus 4.1% average for all doses in adult monotherapy studies), weight increase (differential over placebo 5.2% in children and adolescents), abdominal pain upper (differential over placebo 1.1% in children and adolescents), insomnia (differential over placebo 2.8% in children and adolescents), dizziness (differential over placebo 1% in children and adolescents).

Geriatrics (≥65 years of age)

Clinical studies of LATUDA did not include sufficient numbers of patients aged 65 and older to determine whether or not they respond differently than younger patients. Caution should, thus, be exercised with the use of LATUDA in the elderly patient, recognizing the more frequent hepatic, renal, central nervous system and cardiovascular dysfunctions, and more frequent use of concomitant medications in this population [see also **WARNINGS AND PRECAUTIONS, Hepatic, Renal, DOSAGE AND ADMINISTRATION** and **DRUG INTERACTIONS**].

Use in Geriatric Patients with Dementia

***Overall Mortality:* Elderly patients with dementia treated with atypical antipsychotic drugs have an increased mortality compared to placebo in a meta-analysis of 13 controlled trials of various atypical antipsychotic drugs. LATUDA is not indicated in elderly patients with dementia (e.g., dementia-related psychosis) [see **Boxed Warning**].**

Cerebrovascular Adverse Reactions, including Stroke: In placebo-controlled trials with some atypical antipsychotics in elderly subjects with dementia, there was a higher incidence of cerebrovascular adverse reactions (cerebrovascular accidents and transient ischemic attacks), including fatalities, compared to placebo-treated subjects. LATUDA is not approved for the treatment of patients with dementia (e.g., dementia-related psychosis) [see **Boxed Warning**].

Dysphagia: Esophageal dysmotility and aspiration have been associated with antipsychotic drug use, including LATUDA. Aspiration pneumonia is a common cause of morbidity and mortality in elderly patients, in particular those with advanced Alzheimer's dementia. LATUDA is not indicated for the treatment of dementia-related psychosis, and should not be used in patients at risk for aspiration pneumonia.

Use in Patients with Hepatic Impairment

Caution should be exercised when starting LATUDA in patients with hepatic impairment. The recommended starting dose is 20 mg. Patients should be treated with the lowest effective dose that provides optimal clinical response and tolerability, which is expected to be 20-40 mg once daily for most patients with moderate or severe hepatic impairment (Child Pugh Class B and C). The dose should not exceed 40 mg/day in patients with severe hepatic impairment, and 80 mg/day in

patients with moderate hepatic impairment [see **DOSAGE AND ADMINISTRATION** and **ACTION AND CLINICAL PHARMACOLOGY**].

Use in Patients with Renal Impairment

Caution should be exercised when starting LATUDA in patients with renal impairment. The recommended starting dose is 20 mg. Patients should be treated with the lowest effective dose that provides optimal clinical response and tolerability, which is expected to be 20-40 mg once daily for most patients with moderate and severe renal impairment ($Cl_{cr} \geq 10$ mL/min to < 50 mL/min). The dose should not exceed 80 mg/day in patients with moderate and severe renal impairment [see **DOSAGE AND ADMINISTRATION** and **ACTION AND CLINICAL PHARMACOLOGY**].

Use in Patients with Concomitant Illness

Clinical experience with LATUDA in patients with certain concomitant systemic illnesses is limited. LATUDA has not been evaluated or used to any appreciable extent in patients with a recent history of myocardial infarction or unstable heart disease. Patients with these diagnoses were excluded from premarketing clinical studies.

ADVERSE REACTIONS

Adverse Drug Reaction Overview

The information below is derived from an integrated clinical study database for LATUDA (lurasidone HCl) consisting of 3799 adult patients exposed to one or more doses of LATUDA for the treatment of schizophrenia and bipolar depression in placebo-controlled studies. This experience corresponds to a total experience of 1250.9 patient-years. A total of 1106 LATUDA-treated patients had at least 24 weeks and 371 LATUDA-treated patients had at least 52 weeks of exposure.

The information below is also derived from a short-term (6 week), placebo-controlled adolescent study for schizophrenia in which LATUDA was administered at daily doses of 40 or 80 mg to 214 adolescent patients (13-17 years) and a children and adolescents short-term, placebo-controlled study for bipolar depression in which LATUDA was administered at daily doses ranging from 20 to 80 mg to 175 child and adolescent patients (10 to 17 years). LATUDA is not indicated for the treatment of schizophrenia in adolescents less than 15 years of age or for the treatment of depressive episodes in bipolar I disorder in patients less than 13 years of age due to insufficient safety and efficacy data [see **CLINICAL TRIALS**].

Adverse events during exposure to study treatment were obtained by general inquiry and voluntarily reported adverse experiences, as well as results from physical examinations, vital signs, ECGs, weights, and laboratory investigations. Adverse experiences were recorded by clinical investigators using their own terminology. In order to provide a meaningful estimate of the proportion of individuals experiencing adverse events, events were grouped in standardized categories using MedDRA terminology.

The stated frequencies of adverse reactions represent the proportion of individuals who

experienced at least once, a treatment-emergent adverse event of the type listed. Treatment-emergent adverse events were defined as adverse experiences, which started or worsened on or after the date of the first dose through seven days after study medication discontinuation. There was no attempt to use investigator causality assessments; i.e., all events meeting the defined criteria, regardless of investigator causality are included. It is important to emphasize that, although the reactions occurred during treatment with LATUDA, they were not necessarily caused by it. The label should be read in its entirety to gain an understanding of the safety profile of LATUDA.

Clinical Trial Adverse Drug Reactions

Because clinical trials are conducted under very specific conditions, the adverse reaction rates observed in the clinical trials may not reflect the rates observed in practice and should not be compared to the rates in the clinical trials of another drug. Adverse drug reaction information from clinical trials is useful for identifying drug-related adverse events and for approximating rates.

Short-Term, Placebo-Controlled Trials of Patients with Schizophrenia

Adults

The following findings are based on the 7 short-term, placebo-controlled premarketing studies for schizophrenia in which LATUDA was administered at daily doses ranging from 20 to 160 mg (n=1508) for up to 6 weeks [see also **CLINICAL TRIALS**].

Commonly Observed Treatment-emergent Adverse Events: The most common adverse events (incidence $\geq 5\%$ in all pooled lurasidone patients in the short-term trials and at least twice the rate of placebo) in patients treated with LATUDA were: nausea, somnolence, akathisia, and parkinsonism (see Table 1).

Treatment-emergent Adverse Events Associated with Discontinuation of Treatment: A total of 9.5% (143/1508) of LATUDA-treated patients and 9.3% (66/708) of placebo-treated patients discontinued due to adverse events. There were no adverse events associated with discontinuation in subjects treated with LATUDA that were at least 2% and at least twice the placebo rate. The most frequent adverse events leading to discontinuation in LATUDA-treated patients were psychiatric events related to worsening of schizophrenia (3.4%) and EPS events (1.9%). Of the EPS events, akathisia was 1.4%.

Treatment-emergent Adverse Events Occurring at an Incidence of 2% or More in LATUDA-treated Patients: Adverse events associated with the use of LATUDA by dose group (pooled from different studies for the 40 mg, 80 mg, and 120 mg doses) and all doses pooled (incidence of 2% or greater, rounded to the nearest percent, and LATUDA incidence greater than placebo in all doses pooled) that occurred during acute therapy (up to 6-weeks in patients with schizophrenia) are shown in Table 1.

Table 1: Treatment-emergent Adverse Events in 2% or More of LATUDA-treated Adult Patients and that Occurred at Greater Incidence than in the Placebo-treated Adult Patients in Short-term Schizophrenia Studies

Body System or Organ Class	Percentage of Adult Patients Reporting Event						
	Placebo (N=708)	LATUDA 20 mg/d (N=71)	LATUDA 40 mg/d (N=487)	LATUDA 80 mg/d (N=538)	LATUDA 120 mg/d (N=291)	LATUDA 160 mg/d (N=121)	ALL LATUDA (N=1508)
Gastrointestinal Disorders							
Nausea	5%	11%	10%	9%	13%	7%	10%
Vomiting	6%	7%	6%	9%	9%	7%	8%
Dyspepsia	5%	11%	6%	5%	8%	6%	6%
Salivary Hypersecretion	<1%	1%	1%	2%	4%	2%	2%
Musculoskeletal and Connective Tissue Disorders							
Back Pain	2%	0%	4%	3%	4%	0%	3%
Nervous System Disorders							
Somnolence*	7%	15%	16%	15%	26%	8%	17%
Akathisia	3%	6%	11%	12%	22%	7%	13%
Parkinsonism**	5%	6%	9%	8%	17%	11%	10%
Dizziness	2%	6%	4%	4%	5%	6%	4%
Dystonia***	<1%	0%	3%	4%	7%	2%	4%
Psychiatric Disorders							
Insomnia	8%	8%	10%	11%	9%	7%	10%
Agitation	4%	10%	7%	3%	6%	5%	5%
Anxiety	4%	3%	6%	4%	7%	3%	5%
Restlessness	1%	1%	3%	1%	3%	2%	2%

Note: Figures rounded to the nearest integer

* Somnolence includes adverse event terms: hypersomnia, hypersomnolence, sedation, and somnolence

** Parkinsonism includes adverse event terms: bradykinesia, cogwheel rigidity, drooling, extrapyramidal disorder, hypokinesia, muscle rigidity, parkinsonism, psychomotor retardation, and tremor

*** Dystonia includes adverse event terms: dystonia, oculogyric crisis, oromandibular dystonia, tongue spasm, torticollis, and trismus

Adolescents

The following findings are based on the short-term (6 week), placebo-controlled adolescent study for schizophrenia in which LATUDA was administered at daily doses of 40 or 80 mg (n=214).

Commonly Observed Adverse Reactions: The most common adverse reactions (incidence $\geq 5\%$ and at least twice the rate of placebo) in adolescent patients (13 to 17 years) treated with LATUDA were somnolence, nausea, akathisia, extrapyramidal symptoms (non-akathisia, 40 mg only), rhinorrhea/rhinitis (80 mg only) and vomiting.

Adverse Reactions Associated with Discontinuation of Treatment: The incidence of discontinuation due to adverse events between LATUDA-treated and placebo-treated adolescent patients (13 to 17 years) was 4% and 8%, respectively (6 (5.5%) subjects receiving LATUDA 40 mg/day and 2 (1.9%) subjects receiving LATUDA 80 mg/day versus 9 (8.0%) subjects receiving placebo). Five of the 6 subjects in the LATUDA 40 mg/day dose group discontinued due to psychiatric disorders (anxiety, homicidal ideation, and suicidal ideation, each in 1 subject, and schizophrenia in 2 subjects) and 1 discontinued due to irritability. Of the 2 subjects in the

LATUDA 80 mg/day dose group who discontinued study treatment due to an adverse event, 1 did so due to schizophrenia and the other due to hypersensitivity (allergic reaction).

Adverse Reactions Occurring at an Incidence of 2% or More in LATUDA-Treated Patients: Adverse reactions associated with the use of LATUDA (incidence of 2% or greater, rounded to the nearest percent and lurasidone incidence greater than placebo) that occurred during acute therapy (up to 6-weeks in adolescent patients with schizophrenia) are shown in Table 2.

Table 2: Adverse Reactions in 2% or More of LATUDA-Treated Adolescent Patients and That Occurred at Greater Incidence than in the Placebo-Treated Adolescent Patients in the Short-term Schizophrenia Study

Body System or Organ Class Dictionary-derived Term	Percentage of Patients Reporting Reaction			
	Placebo (N=112)	LATUDA 40 mg/day (N=110)	LATUDA 80 mg/day (N=104)	All LATUDA (N=214)
Gastrointestinal Disorders				
Nausea	3	13	14	14
Vomiting	2	8	6	8
Diarrhea	1	3	5	4
Dry Mouth	0	2	3	2
Infections and Infestations				
Viral Infection**	6	11	10	10
Rhinitis***	2	<1	8	4
Oropharyngeal pain	0	<1	3	2
Cardiac Disorders				
Tachycardia	0	0	3	1
Nervous System Disorders				
Somnolence*	7	15	13	15
Akathisia	2	9	9	9
Dizziness	1	5	5	5

Note: Figures rounded to the nearest integer

* Somnolence includes adverse event terms: hypersomnia, sedation, and somnolence

** Viral Infection includes adverse event terms: nasopharyngitis, influenza, viral infection, upper respiratory tract infection

*** Rhinitis includes adverse event terms: rhinitis, allergic rhinitis, rhinorrhea, and nasal congestion

Short-Term, Placebo-Controlled Trials of Patients with Bipolar Depression

Adults

Monotherapy

The following findings are based on the short-term, placebo-controlled, monotherapy study for bipolar depression (involving lower and higher dose ranges) in which LATUDA was administered at daily doses ranging from 20 to 120 mg (n=331).

Commonly Observed Treatment-emergent Adverse Events: The most common adverse events (incidence \geq 5% and at least twice the rate of placebo) in patients treated with LATUDA were akathisia and parkinsonism.

Treatment-emergent Adverse Events Associated with Discontinuation of Treatment: A total of 6.0% (20/331) of LATUDA-treated patients and 5.4% (9/168) of placebo-treated patients discontinued due to adverse events. There were no adverse events associated with discontinuation in subjects treated with LATUDA that were at least 2% and at least twice the placebo rate.

Treatment-emergent Adverse Events Occurring at an Incidence of 2% or More in LATUDA-treated Patients: Adverse events associated with the use of LATUDA (incidence of 2% or greater, rounded to the nearest percent and LATUDA incidence greater than placebo) that occurred during acute therapy (up to 6 weeks in patients with bipolar depression) are shown in Table 3.

Table 3: Treatment-emergent Adverse Events in 2% or More of LATUDA-treated Adult Patients (Monotherapy) and that Occurred at Greater Incidence than in the Placebo-treated Patients in a Short-term Bipolar Depression Study

Body System or Organ Class Dictionary-derived Term	Percentage of Adult Patients Reporting Reaction			
	Placebo (N=168) (%)	LATUDA 20-60 mg/day (N=164) (%)	LATUDA 80-120 mg/day (N=167) (%)	All LATUDA(N=331) (%)
Gastrointestinal Disorders				
Nausea	8	10	17	14
Dry Mouth	4	6	4	5
Vomiting	2	2	6	4
Diarrhea	2	5	3	4
Infections and infestations				
Nasopharyngitis	1	4	4	4
Influenza	1	<1	2	2
Urinary Tract Infection	<1	2	1	2
Musculoskeletal and Connective Tissue Disorders				
Back Pain	<1	3	<1	2
Nervous System Disorders				
Extrapyramidal Symptoms*	2	5	9	7
Somnolence**	7	7	14	11
Akathisia	2	8	11	9
Psychiatric Disorders				
Anxiety	1	4	5	4

Note: Figures rounded to the nearest integer

* Extrapyramidal symptoms includes adverse event terms: bradykinesia, cogwheel rigidity, drooling, dystonia, extrapyramidal disorder, glabellar reflex abnormal, hypokinesia, muscle rigidity, oculogyric crisis, oromandibular dystonia, parkinsonism, psychomotor retardation, tongue spasm, torticollis, tremor, and trismus

** Somnolence includes adverse event terms: hypersomnia, hypersomnolence, sedation, and somnolence

Adjunctive Therapy

The following findings are based on two short-term, placebo-controlled adjunctive therapy studies for bipolar depression in which LATUDA was administered at daily doses ranging from 20 to 120 mg as adjunctive therapy with lithium or valproate (n=360).

Commonly Observed Treatment-emergent Adverse Events: The most common adverse events (incidence $\geq 5\%$ and at least twice the rate of placebo) in subjects treated with Latuda were akathisia and somnolence.

Treatment-emergent Adverse Events Associated with Discontinuation of Treatment: A total of 5.8% (21/360) of LATUDA-treated patients and 4.8% (16/334) of placebo-treated patients discontinued due to adverse events. There were no adverse events associated with discontinuation in subjects treated with LATUDA that were at least 2% and at least twice the placebo rate.

Treatment-emergent Adverse Events Occurring at an Incidence of 2% or More in LATUDA-treated Patients: Adverse events associated with the use of LATUDA (incidence of 2% or greater, rounded to the nearest percent and LATUDA incidence greater than placebo) that occurred during acute therapy (up to 6 weeks in patients with bipolar depression) are shown in Table 4.

Table 4: Treatment-emergent Adverse Events in 2% or More of LATUDA-treated Adult Patients (Adjunctive Therapy) and that Occurred at Greater Incidence than in the Placebo-treated Patients in a Short-term Bipolar Depression Study

Body System or Organ Class Dictionary-derived Term	Percentage of Patients Reporting Reaction	
	Placebo (N=334)	LATUDA (N=360)
Gastrointestinal Disorders		
Nausea	10	14
Vomiting	1	4
General Disorders		
Fatigue	1	3
Infections and Infestations		
Nasopharyngitis	2	4
Investigations		
Weight increased	1	3
Metabolism and Nutrition Disorders		
Increased Appetite	1	3
Nervous System Disorders		
Extrapyramidal disorder**	9	14
Somnolence*	5	11
Akathisia	5	11
Psychiatric Disorders		
Restlessness	1	4

Note: Figures rounded to the nearest integer

* Somnolence includes adverse event terms: hypersomnia, hypersomnolence, sedation, and somnolence

** Extrapyramidal symptoms includes adverse event terms: bradykinesia, cogwheel rigidity, drooling, dystonia, extrapyramidal disorder, hypokinesia, muscle rigidity, oculogyric crisis, oromandibular dystonia, parkinsonism, psychomotor retardation, tongue spasm, torticollis, tremor, and trismus

Treatment-emergent Adverse Events by Concomitant Use of Lithium or Valproate: A higher incidence of treatment-emergent adverse-events was reported for LATUDA administered with lithium compared with LATUDA administered with valproate. Treatment-emergent adverse events associated with use of LATUDA and lithium-treated subjects with an incidence $\geq 5\%$ and at least twice the rate of LATUDA and valproate-treated subjects were parkinsonism (19% versus 8%).

Children and Adolescents

LATUDA is not indicated for the treatment of depressive episodes in bipolar I disorder in patients less than 13 years of age due to insufficient safety and efficacy data. The following findings are based on the children and adolescents short-term (6 weeks), placebo-controlled study for bipolar depression in which LATUDA was administered at daily doses ranging from 20 to 80 mg (N=175).

Commonly Observed Adverse Reactions: The most common adverse reactions (incidence $\geq 5\%$, and at least twice the rate of placebo) in children and adolescents (10 to 17 years) treated with LATUDA were nausea, weight increase, and insomnia.

Adverse Reactions Associated with Discontinuation of Treatment: The incidence of discontinuation due to adverse reactions between LATUDA- and placebo-treated children and adolescents (10 to 17 years) was 2% and 2%, respectively. Fatigue, restless leg syndrome and bipolar disorder were reported in the LATUDA-treated group. Depression, mania and psychotic disorder were reported in the placebo-treated group.

Adverse Reactions Occurring at an Incidence of 2% or More in LATUDA-Treated Patients: Adverse reactions associated with the use of LATUDA (incidence of 2% or greater, rounded to the nearest percent and LATUDA incidence greater than placebo) that occurred during acute therapy (up to 6 weeks in patients with bipolar depression) are shown in Table 5.

Table 5: Adverse Reactions in 2% or More of LATUDA-Treated Patients and That Occurred at Greater Incidence than in the Placebo-Treated Patients in the Children and Adolescents Short-term Bipolar Depression Study

Body System or Organ Class Dictionary-derived Term	Percentage of Patients Reporting Reaction	
	Placebo (N=172)	LATUDA 20 to 80 mg/day (N=175)
Gastrointestinal Disorders		
Nausea	6	16
Vomiting	4	6
Abdominal Pain Upper	2	3
Diarrhea	2	3
Abdominal Pain	1	3
General Disorders and Administration Site Conditions		
Fatigue	2	3
Investigations		
Weight Increased	2	7
Metabolism and Nutrition Disorders		
Decreased Appetite	2	4
Nervous System Disorders		
Somnolence*	6	11
Extrapyramidal symptoms**	5	6
Dizziness	5	6
Psychiatric Disorders		
Insomnia	2	5
Abnormal Dreams	2	2
Respiratory, Thoracic and Mediastinal Disorders		
Oropharyngeal Pain	2	2

Note: Figures rounded to the nearest integer

*Somnolence includes adverse event terms: hypersomnia, hypersomnolence, sedation, and somnolence

**EPS includes adverse event terms: akathisia, cogwheel rigidity, dyskinesia, dystonia, hyperkinesia, joint stiffness, muscle rigidity, muscle spasms, musculoskeletal stiffness, oculogyric crisis, parkinsonism, tardive dyskinesia, and tremor

Dose-Related Adverse Events

Schizophrenia

Adults

In pooled data from the short-term, placebo-controlled, fixed-dose studies, there were no dose-related adverse events (greater than 5% incidence) in patients treated with LATUDA across the 20 mg/day to 160 mg/day dose range. However, the frequency of akathisia increased with dose up to 120 mg/day (5.6% LATUDA 20 mg, 10.7% LATUDA 40 mg, 12.3% LATUDA 80 mg, and 22.0% LATUDA 120 mg); akathisia was reported by 7.4% (9/121) of patients receiving 160 mg/day. Akathisia occurred in 3.0% of subjects receiving placebo.

Adolescents

In the short-term, placebo-controlled adolescent study for schizophrenia, treatment emergent adverse events reported at an incidence of $\geq 5\%$ in either LATUDA group (or both) and that were more common in the 80 mg/day group than the 40 mg/day group were: nausea (14.4% vs 12.7%); somnolence (11.5% vs 9.1); headache (10.6% vs 6.4%); insomnia (6.7% vs 5.5%); agitation (5.8% vs 4.5%).

Bipolar Depression

Monotherapy

In the short-term, placebo-controlled monotherapy study (involving lower and higher LATUDA dose ranges), the adverse events that occurred with a greater than 5% incidence in the patients treated with LATUDA in any dose group and greater than placebo in both groups were nausea (10.4%, 17.4%), somnolence (7.3%, 13.8%), akathisia (7.9%, 10.8%), parkinsonism (4.9%, 7.8%), and insomnia (4.9%, 6.6%) for LATUDA 20-60 mg/day and LATUDA 80-120 mg/day flexible-dose groups, respectively.

Extrapyramidal Symptoms

Schizophrenia

Adults

In the short-term, placebo-controlled schizophrenia studies in adults, for LATUDA-treated patients, the incidence of reported EPS-related events, excluding akathisia and restlessness, was 13.5% versus 5.8% for placebo-treated patients. The incidence of akathisia for LATUDA-treated patients was 12.9% versus 3.0% for placebo-treated patients. The frequency of EPS events in general increased with dose up to 120 mg/day. Incidence of EPS in adults by dose is provided in Table 6.

Table 6: Percentage of EPS Compared to Placebo in Short-term Schizophrenia Studies in Adults

Adverse Event Term	Placebo (N=708) (%)	LATUDA 20 mg/day (N=71) (%)	LATUDA 40 mg/day (N=487) (%)	LATUDA 80 mg/day (N=538) (%)	LATUDA 120 mg/day (N=291) (%)	LATUDA 160 mg/day (N=121) (%)
All EPS events	9	10	21	23	39	20
All EPS events, excluding Akathisia/Restlessness	6	6	11	12	22	13
Akathisia	3	6	11	12	22	7
Dystonia*	<1	0	4	5	7	2
Parkinsonism**	5	6	9	8	17	11
Restlessness	1	1	3	1	3	2

Note: Figures rounded to the nearest integer

* Dystonia includes adverse event terms: dystonia, oculogyric crisis, oromandibular dystonia, tongue spasm, torticollis, and trismus

** Parkinsonism includes adverse event terms: bradykinesia, cogwheel rigidity, drooling, extrapyramidal disorder, hypokinesia, muscle rigidity, parkinsonism, psychomotor retardation, and tremor

Adolescents

In the short-term, placebo-controlled schizophrenia study in adolescent patients (13 to 17 years), the incidence of extrapyramidal symptoms (EPS), excluding events related to akathisia, for LATUDA-treated patients was higher in the 40 mg (10%) and the 80 mg (7.7%) treatment groups vs. placebo (3.6%); and the incidence of akathisia-related events for LATUDA-treated patients was 8.9% vs. 1.8% for placebo-treated patients. Incidence of EPS in adolescents by dose is provided in Table 7.

Table 7: Incidence of EPS Compared to Placebo in Adolescent Schizophrenia Study

Adverse Event Term	LATUDA		
	Placebo (N=112) (%)	40 mg/day (N=110) (%)	80 mg/day (N=104) (%)
All EPS events	5	14	14
All EPS events, excluding Akathisia/Restlessness	4	10	8
Akathisia	2	9	9
Parkinsonism**	<1	4	0
Dyskinesia	<1	<1	1
Dystonia*	0	<1	1

Note: Figures rounded to the nearest integer

* Dystonia includes adverse event terms: dystonia, trismus, oculogyric crisis, oromandibular dystonia, tongue spasm, and torticollis

** Parkinsonism includes adverse event terms: bradykinesia, drooling, extrapyramidal disorder, glabellar reflex abnormal, hypokinesia, parkinsonism, and psychomotor retardation

Bipolar Depression

Adults

Monotherapy

In the short-term, placebo-controlled monotherapy study, for LATUDA-treated patients, the incidence of reported events related to EPS, excluding akathisia and restlessness, was 6.9% versus 2.4% for placebo-treated patients. The incidence of akathisia for LATUDA-treated patients was 9.4% versus 2.4% for placebo-treated patients. Incidence of EPS by dose groups is provided in Table 8.

Table 8: Percentage of EPS Compared to Placebo in the Monotherapy Bipolar Depression Study in Adults

Adverse Event Term	LATUDA		
	Placebo (N=168) (%)	20 to 60 mg/day (N=164) (%)	80 to 120 mg/day (N=167) (%)
All EPS events	5	12	20
All EPS events, excluding Akathisia/Restlessness	2	5	9
Akathisia	2	8	11
Dystonia*	0	0	2
Parkinsonism**	2	5	8
Restlessness	<1	0	3

Note: Figures rounded to the nearest integer

* Dystonia includes adverse event terms: dystonia, oculogyric crisis, oromandibular dystonia, tongue spasm, torticollis, and trismus

** Parkinsonism includes adverse event terms: bradykinesia, cogwheel rigidity, drooling, extrapyramidal disorder, glabellar reflex abnormal, hypokinesia, muscle rigidity, parkinsonism, psychomotor retardation, and tremor

Adjunctive Therapy

In the short-term, flexible-dose, placebo-controlled adjunctive therapy studies, for LATUDA-treated patients, the incidence of reported events related to EPS, excluding akathisia and restlessness, was 13.9% versus 8.7% for placebo-treated patients. The incidence of akathisia for LATUDA-treated patients was 10.8 % versus 4.8% for placebo-treated patients. Incidence of EPS is provided in Table 9.

Table 9: Percentage of EPS Compared to Placebo in the Adjunctive Therapy Bipolar Depression Studies in Adults

Adverse Event Term	Placebo (N=334) (%)	All LATUDA (N=360) (%)
All EPS events	13	24
All EPS events, excluding Akathisia/Restlessness	9	14
Akathisia	5	11
Dystonia*	1	1
Parkinsonism**	8	13
Restlessness	1	4

Note: Figures rounded to the nearest integer

* Dystonia includes adverse event terms: dystonia, oculogyric crisis, oromandibular dystonia, tongue spasm, torticollis, and trismus

** Parkinsonism includes adverse event terms: bradykinesia, cogwheel rigidity, drooling, extrapyramidal disorder, glabellar reflex abnormal, hypokinesia, muscle rigidity, parkinsonism, psychomotor retardation, and tremor

Children and Adolescents

In the children and adolescents short-term, placebo-controlled study of bipolar depression, the incidence of EPS, excluding events related to akathisia, was similar in the LATUDA 20 to 80 mg/day (3.4%) treatment group to placebo (3.5%); and the incidence of akathisia-related events for LATUDA-treated patients was 2.9% vs. 3.5% for placebo-treated patients. Incidence of EPS is provided in Table 10.

Table 10: Incidence of EPS Compared to Placebo in the Children and Adolescents Bipolar Depression Study

Adverse Event Term	Placebo (N=172) (%)	LATUDA 20 to 80 mg/day (N=175) (%)
All EPS events*	5	6
All EPS events, excluding Akathisia/Restlessness	4	3
Akathisia	4	3
Parkinsonism**	<1	<1
Dystonia***	1	<1
Salivary hypersecretion	<1	<1
Psychomotor hyperactivity	0	<1
Tardive Dyskinesia	<1	0

Note: Figures rounded to the nearest integer

* EPS includes adverse event terms: akathisia, cogwheel rigidity, dyskinesia, dystonia, hyperkinesia, joint stiffness, muscle rigidity, muscle spasms, musculoskeletal stiffness, oculogyric crisis, parkinsonism, tardive dyskinesia, and tremor

** Parkinsonism includes adverse event terms: bradykinesia, drooling, extrapyramidal disorder, glabellar reflex abnormal, hypokinesia, parkinsonism, and psychomotor retardation

***Dystonia includes adverse event terms: dystonia, oculogyric crisis, oromandibular dystonia, tongue spasm, torticollis, and trismus

In the short-term, placebo-controlled schizophrenia and bipolar depression studies, data was objectively collected on the Simpson Angus Rating Scale (SAS) for extrapyramidal symptoms (EPS), the Barnes Akathisia Scale [BAS (for akathisia)], and the Abnormal Involuntary Movement Scale [AIMS (for dyskinesias)].

Schizophrenia

Adults

The mean change from baseline to last assessment for LATUDA-treated adult patients was comparable to placebo-treated patients, with the exception of the BAS total score (LATUDA, 0.2; placebo, 0.0) and global clinical assessment score (LATUDA, 0.1; placebo, 0.0). The percentage of patients who shifted from normal/questionable at baseline to abnormal at any post-baseline assessment was greater in LATUDA-treated patients versus placebo for the BAS global clinical assessment (LATUDA, 18.0%; placebo, 7.8%) and the SAS score (LATUDA, 14.9%; placebo, 6.2%).

Adolescents

The mean change from baseline for LATUDA- treated patients with adolescent schizophrenia for the SAS, BAS and AIMS was comparable to placebo-treated patients. The percentage of patients

who shifted from normal to abnormal was greater in LATUDA-treated patients versus placebo for the BAS (LATUDA, 7.0%; placebo, 1.8%), the SAS (LATUDA, 8.3%; placebo, 2.7%) and the AIMS (LATUDA, 2.8%; placebo, 0.9%).

Bipolar Depression

Adults

Monotherapy

The mean change from baseline for LATUDA-treated patients for the SAS, BAS and AIMS was comparable to placebo-treated patients. The percentage of patients who shifted from normal/questionable at baseline to abnormal at any post-baseline assessment was greater in LATUDA-treated patients versus placebo for the BAS global clinical assessment (LATUDA, 12.1%; placebo, 3.7%) and the SAS score (LATUDA, 8.4%; placebo, 4.3%).

Adjunctive Therapy

The mean change from baseline for LATUDA-treated patients for the SAS, BAS and AIMS was comparable to placebo-treated patients. The percentage of patients who shifted from normal/questionable at baseline to abnormal at any post-baseline assessment was greater in LATUDA-treated patients versus placebo for the BAS global clinical assessment (LATUDA, 12.2%; placebo, 3.2%) and the SAS score (LATUDA, 8.2%; placebo, 6.1%) and the AIMS (LATUDA 1.7%, placebo 0.6%).

Children and Adolescents

The mean change from baseline for LATUDA-treated children and adolescents with bipolar depression for the SAS, BAS and AIMS was comparable to placebo-treated patients. The percentage of patients who shifted from normal to abnormal was greater in LATUDA-treated patients versus placebo for the BAS (LATUDA, 4.6%; placebo, 2.4 %), the SAS (LATUDA, 0.6%; placebo, 0%) and was the same for the AIMS (LATUDA, 0%; placebo, 0%).

Dystonia

Symptoms of dystonia, prolonged abnormal contractions of muscle groups, may occur in susceptible individuals during the first few days of treatment. Dystonic symptoms include: spasm of the neck muscles, sometimes progressing to tightness of the throat, swallowing difficulty, difficulty breathing, and/or protrusion of the tongue. While these symptoms can occur at low doses, they occur more frequently and with greater severity with high potency and at higher doses of first generation antipsychotic drugs. An elevated risk of acute dystonia is observed in males and younger age groups.

Schizophrenia

Adults

In the short-term, placebo-controlled clinical trials, dystonia occurred in 4.2% of LATUDA-treated subjects (0.0% LATUDA 20 mg, 3.5% LATUDA 40 mg, 4.5% LATUDA 80 mg, 6.5% LATUDA 120 mg, and 2.5% LATUDA 160 mg) compared to 0.8% of subjects receiving placebo. Seven

subjects (0.5%, 7/1508) discontinued clinical trials due to dystonic events – four were receiving LATUDA 80 mg/day and three were receiving LATUDA 120 mg/day.

Adolescents

In the short-term, placebo-controlled study of schizophrenia in adolescent patients (13 to 17 years), dystonia occurred in 1% of LATUDA-treated subjects (1% LATUDA 40 mg and 1% LATUDA 80 mg) compared to 0% of subjects receiving placebo. No subject discontinued clinical study due to dystonic events.

Bipolar Depression

Adults

Monotherapy

In the short-term, placebo-controlled monotherapy study, dystonia occurred in 0.9% of LATUDA-treated subjects (0.0% and 1.8% for LATUDA 20-60 mg/day and LATUDA 80-120 mg/day flexible-dose groups, respectively) compared to 0.0% of subjects receiving placebo. No subject discontinued the clinical study due to dystonic events.

Adjunctive Therapy

In the short-term, flexible-dose, placebo-controlled adjunctive therapy studies, dystonia occurred in 1.1% of LATUDA-treated subjects (20-120 mg) compared to 0.6% of subjects receiving placebo. No subject discontinued the clinical study due to dystonic events.

Children and Adolescents

In the children and adolescents short-term, placebo-controlled bipolar depression study, dystonia occurred in 0.6% of LATUDA-treated patients compared to 1.2% of patients receiving placebo. No patients discontinued the clinical study due to dystonic events.

Weight Gain

Schizophrenia

Adults

Pooled data from short-term, placebo-controlled schizophrenia studies are presented in Table 11. The mean weight change was a 0.43 kg increase for LATUDA-treated patients compared to a 0.02 kg decrease for placebo-treated patients. In two 6-week studies that included active comparators, the mean weight gain at the last assessment in the study was 0.98 kg for LATUDA 40 mg, 1.05 kg for LATUDA 120 mg, and 4.15 kg for olanzapine 15 mg in one study, and 0.62 kg for LATUDA 80 mg, 0.60 kg for LATUDA 160 mg, and 2.09 kg for quetiapine XR 600 mg in another study. The proportion of patients with a $\geq 7\%$ increase in body weight (at Endpoint) was 4.8% for LATUDA-treated patients versus 3.3% for placebo-treated patients.

Table 11: Mean Change in Weight (kg) from Baseline to Last Assessment in Short-term Schizophrenia Studies in Adults

	Placebo (n=696)	LATUDA 20 mg/day (n=71)	LATUDA 40 mg/day (n=484)	LATUDA 80 mg/day (n=526)	LATUDA 120 mg/day (n=291)	LATUDA 160 mg/day (n=114)
All Patients	-0.02	-0.15	0.22	0.54	0.68	0.60

Adolescents

Data from the short-term, placebo-controlled adolescent schizophrenia study are presented in Table 12. The mean weight gain was 0.5 kg for LATUDA-treated patients (0.3 kg for 40 mg and 0.7 kg for 80 mg dose) compared to 0.2 kg for placebo-treated patients. The proportion of patients with a $\geq 7\%$ increase in body weight (at Endpoint) was 2.3% for LATUDA-treated patients (2.8% for 40 mg and 1.9% for 80 mg dose) versus 4.5% for placebo-treated patients. Weight gain as an adverse event was reported in 3 (2.9%) subjects receiving LATUDA 80 mg/day, 1 (0.9%) subject receiving LATUDA 40 mg/day, and 3 (2.7%) subjects receiving placebo.

Table 12: Mean Change in Weight (kg) from Baseline in Adolescent Schizophrenia Study

	Placebo (n=111)	LATUDA	
		40 mg/day (n=109)	80 mg/day (n=104)
All Patients	+0.2	+0.3	+0.7

Bipolar Depression

Adults

Monotherapy

Data from the short-term, placebo-controlled monotherapy study are presented in Table 13. The mean weight gain was 0.29 kg for LATUDA-treated patients compared to -0.04 kg for placebo-treated patients. The proportion of patients with a $\geq 7\%$ increase in body weight (at Endpoint) was 2.4% for LATUDA-treated patients versus 0.7% for placebo-treated patients.

Table 13: Mean Change in Weight (kg) from Baseline in the Monotherapy Bipolar Depression Study in Adults

	Placebo (n=151)	LATUDA	
		20 to 60 mg/day (n=143)	80 to 120 mg/day (n=147)
All Patients	-0.04	0.56	0.02

Patients were randomized to flexibly dosed LATUDA 20-60 mg/day, LATUDA 80-120 mg/day or placebo

Adjunctive Therapy

Data from the short-term, flexible-dose, placebo-controlled adjunctive therapy studies are presented in Table 14. The mean weight gain was 0.11 kg for LATUDA-treated patients compared to 0.16 kg for placebo-treated patients. The proportion of patients with a $\geq 7\%$ increase in body weight (at Endpoint) was 3.1% for LATUDA-treated patients versus 0.3% for placebo-treated patients.

Table 14: Mean Change in Weight (kg) from Baseline in the Adjunctive Therapy Bipolar Depression Studies in Adults

	Placebo (n=334)	LATUDA 20 to 120 mg/day (n=360)
All Patients	0.16	0.11

Patients were randomized to flexibly dosed LATUDA 20-120 mg/day or placebo as adjunctive therapy with lithium or valproate.

Children and Adolescents

Data from the children and adolescents short-term, placebo-controlled bipolar depression study are presented in Table 15. Seven percent (7%) of LATUDA-treated patients reported weight gain as an adverse event compared to 2% of placebo-treated patients. The mean weight gain was 0.7 kg for LATUDA-treated patients compared to 0.5 kg for placebo-treated patients. The proportion of patients with a $\geq 7\%$ increase in body weight (at Endpoint) was 4.0% for LATUDA-treated patients versus 5.3% for placebo-treated patients.

Table 15: Mean Change in Weight (kg) from Baseline in the Children and Adolescents Bipolar Depression Study

	Placebo (n=170)	LATUDA 20 to 80 mg/day (n=175)
All Patients	+0.5	+0.7

Constipation

Patients should be advised of the risk of severe constipation during LATUDA treatment, and they should tell their doctor if constipation occurs or worsens, since they may need laxatives.

Less Common Clinical Trial Adverse Drug Reactions (<2%)

Following is a list of MedDRA terms that reflect adverse events reported by patients treated with LATUDA at multiple doses of ≥ 20 mg once daily during any phase of a study within the database of 2905 adult patients. The events listed are those that could be of clinical importance, as well as events that are plausibly drug-related on pharmacologic or other grounds. Events listed in Table 1 are not included. Although the events reported occurred during treatment with LATUDA, they were not necessarily caused by it.

Events are further categorized by MedDRA system organ class and listed in order of decreasing frequency according to the following definitions: those occurring in at least 1/100 patients (frequent) (only those not already listed in the tabulated results from placebo-controlled studies appear in this listing); those occurring in 1/100 to 1/1000 patients (infrequent); and those occurring in fewer than 1/1000 patients (rare).

Blood and Lymphatic System Disorders:

Infrequent: anemia;

Rare: leukopenia, neutropenia

Cardiac Disorders:

Frequent: tachycardia;

Infrequent: AV block 1st degree, angina pectoris, bradycardia, ventricular extrasystoles, arrhythmia

Ear and Labyrinth Disorders:

Infrequent: tinnitus, vertigo

Eye Disorders:

Frequent: blurred vision;

Infrequent: visual impairment

Gastrointestinal Disorders:

Frequent: abdominal pain, constipation, diarrhea, dry mouth;

Infrequent: gastritis, gastroesophageal reflux disease, dysphagia, tongue disorder;

Rare: swollen tongue

General Disorders and Administrative Site Conditions:

Frequent: fatigue, pyrexia;

Infrequent: asthenia, gait disturbance, irritability, peripheral edema, sudden death

Hepatobiliary Disorders:

Infrequent: hepatic function abnormal, hepatic steatosis, jaundice

Immune System Disorders:

Rare: drug hypersensitivity

Investigations:

Frequent: blood prolactin increased, blood triglycerides increased, CPK increased, weight increased, weight decreased;

Infrequent: blood pressure decreased, blood uric acid increased, body temperature increased, white blood cell count increased;

Rare: electrocardiogram T wave inversion

Metabolism and Nutritional System Disorders:

Frequent: decreased appetite;

Infrequent: anorexia, dehydration, diabetes mellitus, increased appetite

Musculoskeletal and Connective Tissue Disorders:

Frequent: musculoskeletal stiffness, myalgia;

Rare: rhabdomyolysis

Nervous System Disorders:

Frequent: dyskinesia;

Infrequent: tardive dyskinesia, cerebrovascular accident, convulsion, dysarthria, dysgeusia, hypoaesthesia, paresthesia, syncope;

Rare: neuroleptic malignant syndrome, seizure

Psychiatric Disorders:

Frequent: depression;

Infrequent: abnormal dreams, apathy, confusional state, hostility, panic attack, sleep disorder, suicidal ideation, completed suicide, suicide attempt;

Rare: somnambulism, suicidal behavior

Renal and Urinary Disorders:

Infrequent: dysuria, urinary incontinence;

Rare: renal failure

Reproductive System and Breast Disorders:

Infrequent: amenorrhea, dysmenorrhea, menstruation irregular, erectile dysfunction;

Rare: breast enlargement, breast pain, galactorrhea

Respiratory disorders:

Infrequent: dyspnea;

Rare: pneumonia aspiration

Skin and Subcutaneous Tissue Disorders:

Frequent: rash (including erythematous, exfoliative, generalized, maculopapular, papular rash, pruritic; atopic, allergic, contact, seborrheic dermatitis, neurodermatitis), pruritus;

Infrequent: hyperhidrosis, urticaria;

Rare: angioedema

Vascular Disorders:

Frequent: hypertension;

Infrequent: hot flush, hypotension, orthostatic hypotension;

Rare: thrombophlebitis superficial

Pediatric and adolescent patients (10-17 years of age) with bipolar depression

Most adverse reactions observed in the pediatric and adolescent patients with bipolar depression aged 10 - 17 years were also observed in the adult population. Additional adverse reactions observed in the pediatric and adolescent population are listed below.

Investigations:

Frequent: C-Reactive Protein Increased

Abnormal Hematologic and Clinical Chemistry Findings**Laboratory Test Abnormalities**

In a between-group comparison of the pooled data from short-term, placebo-controlled studies, there were no clinically important changes in total cholesterol measurements, triglycerides, or glucose from Baseline to Endpoint [see **WARNINGS AND PRECAUTIONS**]. There were also no clinically important differences between LATUDA and placebo in mean change from baseline to endpoint in routine hematology, urinalysis, or serum chemistry. LATUDA was associated with a dose-related increase in prolactin concentration [see **WARNINGS AND PRECAUTIONS**].

Glucose:

Schizophrenia

Adults

Pooled data from short-term, placebo-controlled schizophrenia studies are presented in Table 16.

Table 16: Change in Fasting Glucose in Schizophrenia Studies from Baseline to Last Study Assessment in Pooled Short-term Studies in Adults

	Placebo	LATUDA 20 mg/day	LATUDA 40 mg/day	LATUDA 80 mg/day	LATUDA 120 mg/day	LATUDA 160 mg/day
Mean Change from Baseline (mmol/L)						
	n=601	n=70	n=417	n=481	n=220	N=97
Serum Glucose	0.03	-0.11	0.13	-0.01	0.12	0.21
Proportion of Patients with Shifts to ≥ 7 mmol/L						
Serum Glucose (≥ 7 mmol/L)	5.8% (33/565)	8.2% (5/61)	9.6% (38/395)	5.3% (24/452)	4.8% (10/209)	5.3% (5/95)

Adolescents

Data from the short-term (6 week), placebo-controlled schizophrenia study are presented in Table 17.

Table 17: Change in Fasting Glucose in Adolescent Schizophrenia Study

	Placebo	LATUDA 40 mg/day	LATUDA 80 mg/day
Mean Change from Baseline (mmol/L)			
	n=95	n=90	n=92
Serum Glucose	-0.07	+0.01	+0.10
Proportion of Patients with Shifts to ≥ 7 mmol/L			
Serum Glucose ≥ 7 mmol/L)	0% (0/95)	0% (0/90)	1% (1/92)

Bipolar Depression

Adults

Monotherapy

Data from the short-term, placebo-controlled monotherapy study are presented in Table 18.

Table 18: Change in Fasting Glucose in the Monotherapy Bipolar Depression Study in Adults

	Placebo	LATUDA	
		20 to 60 mg/day	80 to 120 mg/day
Mean Change from Baseline (mmol/L)			
	n=148	n=140	n=143
Serum Glucose	0.10	-0.04	0.10
Proportion of Patients with Shifts to ≥ 7 mmol/L			
Serum Glucose (≥ 7 mmol/L)	4.3% (6/141)	2.2% (3/138)	6.4% (9/141)

Patients were randomized to flexibly dosed LATUDA 20-60 mg/day, LATUDA 80-120 mg/day or placebo

Adjunctive Therapy

Data from the short-term, flexible-dose, placebo-controlled adjunctive therapy studies are presented in Table 19.

Table 19: Change in Fasting Glucose in the Adjunctive Therapy Bipolar Depression Studies in Adults

	Placebo	LATUDA
		20 to 120 mg/day
Mean Change from Baseline (mmol/L)		
	n=302	n=319
Serum Glucose	0.05	0.07
Proportion of Patients with Shifts to ≥ 7 mmol/L		
Serum Glucose (≥ 7 mmol/L)	1.0% (3/290)	1.3% (4/316)

Patients were randomized to flexibly dosed LATUDA 20-120 mg/day or placebo as adjunctive therapy with lithium or valproate.

Children and Adolescents

Data from the short-term, placebo-controlled bipolar depression study are presented in Table 20.

Table 20: Change in Fasting Glucose in the Children and Adolescents Bipolar Depression Study

	Placebo	20 to 80 mg/day
Mean Change from Baseline at Endpoint (mmol/L)		
	n=145	n=145
Serum Glucose	-0.03	0.08
Proportion of Patients with Shifts to ≥ 7 mmol/L During the Post-Baseline Treatment Period		
Serum Glucose (≥ 7 mmol/L)	0% (0/148)	1.3% (2/150)

Cholesterol and Triglycerides:

Schizophrenia

Adults

Pooled data from short-term, placebo-controlled schizophrenia studies with lurasidone are presented in Table 21.

Table 21: Change in Fasting Lipids in Schizophrenia Studies from Baseline to Last Study Assessment in Pooled Short-term Studies in Adults

	Placebo	LATUDA 20 mg/day	LATUDA 40 mg/day	LATUDA 80 mg/day	LATUDA 120 mg/day	LATUDA 160 mg/day
Mean Change from Baseline (mmol/L)						
	n=567	n=70	n=387	n=465	n=182	n=100
Total cholesterol	-0.15	-0.29	-0.12	-0.15	-0.13	-0.19
Triglycerides	-0.17	-0.36	-0.11	-0.18	-0.06	-0.17
Proportion of Patients with Shifts						
Total cholesterol (≥ 6.2 mmol/L)	5.2% (26/497)	12.1% (7/58)	5.6% (19/339)	5.2% (21/405)	2.5% (4/161)	4.5% (4/88)
Triglycerides (≥ 2.3 mmol/L)	7.7% (36/467)	10.0% (5/50)	7.4% (24/323)	5.9% (22/371)	6.5% (10/154)	4.7% (4/85)

Adolescents

Data from short-term (6 week), placebo-controlled schizophrenia study for adolescent (13 to 17 years) patients are presented in Table 22.

Table 22: Change in Fasting Lipids in Adolescent Schizophrenia Study

	Placebo	LATUDA	
		40 mg/day	80 mg/day
Mean Change from Baseline (mmol/L)			
	n=95	n=89	n=92
Total cholesterol	-0.25	-0.11	+0.04
Triglycerides	+0.00	-0.01	+0.10
Proportion of Patients with Shifts			
Total Cholesterol (≥ 6.0 mmol/L)	0% (0/95)	0% (0/89)	3.3% (3/92)
Triglycerides (≥ 2.3 mmol/L)	7.4% (7/95)	3.4% (3/89)	3.3% (3/92)

Bipolar Depression

Adults

Monotherapy

Data from the short-term, placebo-controlled, monotherapy study are presented in Table 23.

Table 23: Change in Fasting Lipids in the Monotherapy Bipolar Depression Study in Adults

	Placebo	LATUDA	
		20 to 60 mg/day	80 to 120 mg/day
Mean Change from Baseline (mmol/L)			
	n=133	n=125	n=134
Total cholesterol	-0.09	0.04	-0.13
Triglycerides	0.02	0.08	0.02
Proportion of Patients with Shifts			
Total cholesterol (≥ 6.2 mmol/L)	3.8% (4/104)	3.9% (4/102)	4.7% (5/107)
Triglycerides (≥ 2.3 mmol/L)	3.5% (4/114)	11.1% (12/108)	10.4% (12/115)

Patients were randomized to flexibly dosed LATUDA 20-60 mg/day, LATUDA 80-120 mg/day or placebo

Adjunctive Therapy

Data from the short-term, flexible-dose, placebo-controlled, adjunctive therapy studies are presented in Table 24.

Table 24: Change in Fasting Lipids in the Adjunctive Therapy Bipolar Depression Studies in Adults

	Placebo	LATUDA 20 to 120 mg/day
	Mean Change from Baseline (mmol/L)	
	n=273	n=290
Total cholesterol	-0.08	-0.10
Triglycerides	-0.11	0.11
Proportion of Patients with Shifts		
Total cholesterol (≥ 6.2 mmol/L)	6.0% (14/235)	5.6% (14/251)
Triglycerides (≥ 2.3 mmol/L)	8.6% (19/220)	10.8% (26/240)

Patients were randomized to flexibly dosed LATUDA 20-120 mg/day or placebo as adjunctive therapy with lithium or valproate.

Children and Adolescents

Data from the short-term, placebo-controlled bipolar depression study for children and adolescents (10 to 17 years) are presented in Table 25.

Table 25: Change in Fasting Lipids in the Children and Adolescents Bipolar Depression Study

	Placebo	LATUDA 20 to 80 mg/day
	Mean Change from Baseline at Endpoint (mmol/L)	
	n=145	n=144
Total cholesterol	-0.04	-0.16
Triglycerides	0.07	-0.09
Proportion of Patients with Shifts During the Post-Baseline Treatment Period		
Total cholesterol (≥ 6.2 mmol/L)	3.4% (5/148)	1.3% (2/149)
Triglycerides (male: ≥ 2.3 mmol/L; female: ≥ 1.9 mmol/L)	5.4% (8/148)	5.4% (8/149)

Hyperprolactinemia:

Schizophrenia

Adults

In short-term, placebo-controlled schizophrenia studies, the median change from baseline to endpoint in prolactin levels for LATUDA-treated patients was 0.4 ng/mL and -1.9 ng/mL in placebo-treated patients. The median change from baseline to endpoint for males was 0.5 ng/mL and for females was -0.2 ng/mL. The mean change from baseline to endpoint in prolactin levels in LATUDA-treated patients with normal prolactin levels at baseline (n=1039) was 8.6 ng/mL compared to 0.4 ng/mL in placebo-treated patients (n=460), and was higher in female patients (18.4 ng/mL) compared to male patients (4.8 ng/mL).

The proportion of patients with prolactin elevations $\geq 5X$ ULN was 2.8% for LATUDA-treated patients versus 1.0% for placebo-treated patients. The proportion of female patients with prolactin elevations $\geq 5X$ ULN was 5.7% for LATUDA-treated patients versus 2.0% for placebo-treated female patients. The proportion of male patients with prolactin elevations $\geq 5X$ ULN was 1.6% versus 0.6% for placebo-treated male patients. The proportion of patients with elevations ($\geq 5X$ ULN) in prolactin at any post-baseline assessment in the pooled short-term studies is shown in Table 26.

Table 26: Proportion of Patients with Elevations ($\geq 5X$ ULN) in Prolactin (ng/mL) at any Post-baseline Assessment in Pooled Short-term Schizophrenia Studies in Adults

	Placebo	LATUDA 20 mg/day	LATUDA 40 mg/day	LATUDA 80 mg/day	LATUDA 120 mg/day	LATUDA 160 mg/day
All Patients	1.0% (n=673)	2.9% (n=70)	2.9% (n=476)	2.2% (n=495)	4.2% (n=284)	0.9% (n=115)
Females	2.0% (n=200)	10.5% (n=19)	6.0% (n=149)	3.3% (n=150)	10.0% (n=70)	2.8% (n=36)
Males	0.6% (n=473)	0% (n=51)	1.5% (n=327)	1.7% (n=345)	2.3% (n=214)	0% (n=79)

Adolescents

In a short-term (6 week), placebo-controlled adolescent schizophrenia study, the median change from baseline to endpoint in prolactin levels for LATUDA-treated patients was +1.1 ng/mL and was +0.1 ng/mL in the placebo-treated patients. For LATUDA-treated patients, the median change from baseline to endpoint for males was +1.0 ng/mL and for females was +2.6 ng/mL. Median changes for prolactin by dose are shown in Table 27.

The mean change (\pm SD) from baseline to endpoint in serum prolactin was -0.8 ng/mL, +0.9 ng/mL, and +4.0 ng/mL in the placebo, lurasidone 40 mg/day and 80 mg/day groups, respectively.

The proportion of patients with prolactin elevations $\geq 5X$ ULN was 0.5% for LATUDA-treated patients (1.0% for 40 mg and 0% for 80 mg dose) versus 1.0% for placebo-treated patients. The proportion of female patients with prolactin elevations $\geq 5X$ ULN was 1.3% for LATUDA-treated patients (2.4% for 40 mg and 0% for 80 mg dose) versus 0% for placebo-treated female patients. The proportion of male patients with prolactin elevations $\geq 5X$ ULN was 0% versus 1.6% for placebo-treated male patients.

Table 27: Median Change in Prolactin (ng/mL) from Baseline in Adolescent Schizophrenia Study

	Placebo	LATUDA 40 mg/day	LATUDA 80 mg/day
All Patients	+0.10 (n=103)	+0.75 (n=102)	+1.20 (n=99)
Females	+0.70 (n=39)	+0.60 (n=42)	+4.40 (n=33)
Males	0.00 (n=64)	+0.75 (n=60)	+1.00 (n=66)

Bipolar Depression

Adults

Monotherapy

The median change from baseline to endpoint in prolactin levels, in the short-term, placebo-controlled monotherapy study, was 1.7 ng/mL and 3.5 ng/mL with LATUDA 20-60 mg/day and LATUDA 80-120 mg/day flexible-dose groups, respectively, compared to 0.3 ng/mL with placebo-treated patients. The median change from baseline to endpoint for males was 1.5 ng/mL and for females was 3.1 ng/mL, the mean change from baseline to endpoint in prolactin levels in LATUDA-treated patients with normal prolactin levels at baseline (n=260) was 6.5 ng/mL compared to 1.4 ng/mL in placebo-treated patients (n=130), and was higher in female patients (7.7 ng/mL) compared to male patients (4.9 ng/mL).

The proportion of patients with prolactin elevations $\geq 5X$ upper limit of normal (ULN) was 0.4% for LATUDA-treated patients versus 0.0% for placebo-treated patients. The proportion of female patients with prolactin elevations $\geq 5X$ ULN was 0.6% for LATUDA-treated patients versus 0% for placebo-treated female patients. There were no prolactin elevations $\geq 5X$ ULN in male patients. The proportion of patients with elevations ($\geq 5X$ ULN) in prolactin at any post-baseline assessment is shown in Table 28.

Table 28: Proportion of Patients with Elevations ($\geq 5X$ ULN) in Prolactin (ng/mL) at any Post-baseline Assessment in the Monotherapy Bipolar Depression Study in Adults

	Placebo	LATUDA 20 to 60 mg/day	LATUDA 80 to 120 mg/day
All Patients	0% (n=147)	0.7% (n=140)	0% (n=144)
Females	0% (n=82)	1.3% (n=78)	0% (n=88)

Adjunctive Therapy

The median change from baseline to endpoint in prolactin levels, in the short-term, flexible-dose, placebo-controlled adjunctive therapy studies, was 2.8 ng/mL with LATUDA 20-120 mg/day compared to 0.0 ng/mL with placebo-treated patients. The median change from baseline to endpoint for males was 2.4 ng/mL and for females was 3.2 ng/mL. The mean change from baseline to endpoint in prolactin levels in LATUDA-treated patients with normal prolactin levels at baseline (n=291) was 6.2 ng/mL compared to 0.9 ng/mL in placebo-treated patients (n=274), and was higher in female patients (8.4 ng/mL) compared to male patients (3.9 ng/mL). There were no patients with prolactin elevations $\geq 5X$ ULN.

Children and Adolescents

In the children and adolescents short-term, placebo-controlled bipolar depression study, the median change from baseline to endpoint in prolactin levels for LATUDA-treated patients was +1.10 ng/mL and was +0.50 ng/mL for placebo-treated patients. For LATUDA-treated patients, the median change from baseline to endpoint for males was +0.85 ng/mL and for females was +2.50 ng/mL. Median changes for prolactin are shown in Table 29.

Table 29: Median Change in Prolactin (ng/mL) from Baseline in the Children and Adolescents Bipolar Depression Study

	Placebo	LATUDA 20 to 80 mg/day
All Patients	+0.50 (n=157)	+1.10 (n=165)
Females	+0.55 (n=78)	+2.50 (n=83)
Males	+0.50 (n=79)	+0.85 (n=82)

The proportion of patients with prolactin elevations $\geq 5X$ ULN was 0% for LATUDA-treated patients versus 0.6% for placebo-treated patients. The proportion of female patients with prolactin elevations $\geq 5X$ ULN was 0% for LATUDA-treated patients versus 1.3% for placebo-treated female patients. The proportion of male patients with prolactin elevations $\geq 5X$ ULN was 0% for LATUDA-treated patients versus 0% for placebo-treated male patients.

Creatinine:

Schizophrenia

Adults

In short-term, placebo-controlled trials, the mean change from baseline in creatinine was 5.3 $\mu\text{mol/L}$ for LATUDA-treated patients compared to 1.7 $\mu\text{mol/L}$ for placebo-treated patients. A creatinine shift from normal to high occurred in 3.0% (43/1453) of LATUDA-treated patients and 1.6% (11/681) on placebo. The mean changes from baseline and the proportion of shifts to high generally increased with increased lurasidone doses (Table 30). The threshold for high creatinine values varied from >70 to >115 $\mu\text{mol/L}$ based on the centralized laboratory definition for each study [see **DOSAGE AND ADMINISTRATION** and **WARNINGS AND PRECAUTIONS, Special Populations**].

Table 30: Change in Creatinine from Baseline to Last Study Assessment in Pooled Short-term Studies in Adults

	Placebo	LATUDA 20 mg/day	LATUDA 40 mg/day	LATUDA 80 mg/day	LATUDA 120 mg/day	LATUDA 160 mg/day
Mean Change from Baseline ($\mu\text{mol/L}$)						
	n=681	n=71	n=478	n=506	n=283	n=115
Creatinine	1.8	2.7	3.5	4.4	6.2	8.8
Proportion of Patients with Shifts from Normal to Abnormal						
Creatinine	1.6% (11/681)	1.4% (1/71)	1.9% (9/478)	2.2% (11/506)	4.9% (14/283)	7.0% (8/115)

Adolescents

In the short-term, placebo-controlled study of schizophrenia in adolescent patients (13 to 17 years), the mean change from Baseline in creatinine was $-0.796 \mu\text{mol/L}$ for LATUDA-treated patients compared to $+1.503 \mu\text{mol/L}$ for placebo-treated patients. A creatinine shift from normal to high (based on the centralized laboratory definition) occurred in 7.2% (14/194) of LATUDA-treated patients and 2.9% (3/103) on placebo (Table 31).

Table 31: Serum Creatinine Shifts from Normal at Baseline to High at Study End-Point in Adolescent Schizophrenia Study

Laboratory Parameter	Placebo (N=103)	LATUDA 40 mg/day (N=97)	LATUDA 80 mg/day (N=97)
Serum Creatinine Elevated	2.9%	7.2%	7.2%

Bipolar Depression

Adults

Monotherapy

In the short-term, placebo-controlled monotherapy study, the mean change from Baseline in creatinine was 0.9 $\mu\text{mol/L}$ for LATUDA-treated patients compared to -1.8 $\mu\text{mol/L}$ for placebo-treated patients. A creatinine shift from normal to high occurred in 2.8% (9/322) of LATUDA-treated patients and 0.6% (1/162) on placebo (Table 32).

Table 32: Change in Creatinine from Baseline to Last Study Assessment in the Monotherapy Bipolar Depression Study in Adults

	Placebo	LATUDA 20 to 60 mg/day	LATUDA 80 to 120 mg/day
Mean Change from Baseline ($\mu\text{mol/L}$)			
	n=162	n=161	n=161
Creatinine	-1.8	0.9	1.8
Proportion of Patients with Shifts from Normal to Abnormal			
Creatinine	0.6% (1/162)	1.9% (3/161)	3.7% (6/161)

Adjunctive Therapy

In the short-term, flexible-dose, placebo-controlled adjunctive therapy studies, the mean change from Baseline in creatinine was 3.5 $\mu\text{mol/L}$ for LATUDA-treated patients compared to -0.9 $\mu\text{mol/L}$ for placebo-treated patients. A creatinine shift from normal to high occurred in 4.3% (15/348) of LATUDA-treated patients and 1.6% (5/316) on placebo (Table 33).

Table 33: Change in Creatinine from Baseline to Last Study Assessment in the Adjunctive Therapy Bipolar Depression Studies in Adults

	Placebo	LATUDA 20 to 120 mg/day
Mean Change from Baseline ($\mu\text{mol/L}$)		
	n=316	n=348
Creatinine	-0.9	3.5
Proportion of Patients with Shifts from Normal to Abnormal		
Creatinine	1.6% (5/316)	4.3% (15/348)

Children and Adolescents

In the children and adolescents short-term, placebo-controlled bipolar depression study, the mean change from Baseline in serum creatinine was 1.9 $\mu\text{mol/L}$ for LATUDA-treated patients compared

to 0.8 µmol/L for placebo-treated patients. A creatinine shift from normal to high (based on the centralized laboratory definition) occurred in 6.7% (11/163) of LATUDA-treated patients and 4.5% (7/155) on placebo (Table 34).

Table 34: Change in Creatinine from Baseline to Study Endpoint in the Children and Adolescents Bipolar Depression Study

	Placebo	LATUDA 20 to 80 mg/day
Mean Change from Baseline at Endpoint (µmol/L)		
	(n=155)	(n=163)
Creatinine	0.8	1.9
Proportion of Patients with Shifts from Normal to Abnormal at Endpoint		
Creatinine	4.5% (7/155)	6.7% (11/163)

Post-Market Adverse Drug Reactions

Hyponatremia has been identified during post-market use of LATUDA.

Atypical antipsychotic drugs, such as lurasidone, have been associated with cases of sleep apnea, with or without concomitant weight gain. In patients who have a history of or are at risk for sleep apnea, LATUDA should be prescribed with caution.

Risks of somnambulism (sleep walking) and sleep-related eating disorder have been associated with the use of atypical antipsychotics including LATUDA.

DRUG INTERACTIONS

Overview

LATUDA (lurasidone HCl) is contraindicated with strong CYP3A4 inhibitors (e.g., ketoconazole) and strong CYP3A4 inducers (e.g., rifampin) [see **CONTRAINDICATIONS**]. LATUDA should be started at a dose of 20 mg/day, and the dose should not exceed 40 mg/day if coadministered with moderate CYP3A4 inhibitors.

The use of LATUDA should be avoided in combination with drugs known to prolong QTc interval or cause electrolyte disturbances [see **WARNINGS AND PRECAUTIONS, Cardiovascular, QT Interval**].

Drug-Drug Interactions

Potential for Other Drugs to Affect LATUDA

Cytochrome P450 enzyme inhibitors or inducers: LATUDA is predominantly metabolized by CYP3A4; interaction of LATUDA with strong and moderate inhibitors or inducers of this enzyme has been observed (Table 35). LATUDA is contraindicated in combination with strong inhibitors or inducers of this enzyme [see **CONTRAINDICATIONS**].

Table 35: Summary of Effect of Coadministered Drugs on Exposure to LATUDA in Healthy Subjects or Patients with Schizophrenia

Coadministered Drug	Ref	Dose Schedule		Effect on LATUDA Pharmacokinetics		Recommendation
		Coadministered Drug	LATUDA	C _{max}	AUC	
Ketoconazole (strong CYP3A4 inhibitor)	CT	400 mg/day for 5 days	10 mg single dose	6.9-times LATUDA alone	9.0-times LATUDA alone	Contraindicated in combination with LATUDA
Diltiazem (moderate CYP3A4 inhibitor)	CT	240 mg/day for 5 days	20 mg single dose	2.1-times LATUDA alone	2.2-times LATUDA alone	LATUDA dose should not exceed 40 mg/day if coadministered
Rifampin (strong CYP3A4 inducer)	CT	600 mg/day for 8 days	40 mg single dose	1/7 th of LATUDA alone	1/5 th of LATUDA alone	Contraindicated in combination with LATUDA
Lithium	CT	600 mg BID for 8 days	120 mg/day for 8 days	0.9-times LATUDA alone	1.1-times LATUDA alone	No LATUDA dose adjustment required.

Legend: CT = Clinical Trial

Transporter inhibitors: Lurasidone is a substrate of P-gp and BCRP *in vitro* and the *in vivo* relevance of this is unclear. Coadministration of lurasidone with P-gp and BCRP inhibitors may increase exposure to lurasidone.

Potential for LATUDA to Affect Other Drugs

Midazolam (CYP3A4 substrate): Coadministration of LATUDA (120 mg/day) at steady state with a single dose of 5 mg midazolam increased midazolam C_{max} and AUC₍₀₋₂₄₎ by approximately 21% and 44%, respectively, relative to midazolam alone. Midazolam dose adjustment is not required when coadministered with LATUDA.

Oral Contraceptive (estrogen/progesterone): Coadministration of LATUDA (40 mg/day) at steady state with an oral contraceptive (OC) containing ethinyl estradiol and norelgestromin resulted in equivalent AUC₀₋₂₄ and C_{max} of ethinyl estradiol and norelgestromin relative to OC administration alone. Also, sex hormone binding globulin levels were not meaningfully affected by coadministration of LATUDA and OC. Dose adjustment of OC dose is not required when

coadministered with LATUDA.

Transporter substrates: Coadministration of LATUDA (120 mg/day) at steady state with a single 0.25 mg dose of digoxin, a P-gp substrate, increased mean C_{max} and $AUC_{(0-24)}$ for digoxin by approximately 9% and 13%, respectively, relative to digoxin alone. Digoxin dose adjustment is not generally required when coadministered with LATUDA.

Lurasidone is an *in vitro* inhibitor of the efflux transporter P-gp and the clinical relevance of intestinal P-gp inhibition cannot be excluded. Concomitant administration of the P-gp substrate dabigatran etexilate may result in increased dabigatran plasma concentrations.

Lurasidone is an *in vitro* inhibitor of the efflux transporter BCRP and the clinical relevance of intestinal BCRP inhibition cannot be excluded. Concomitant administration of BCRP substrates may result in increases in the plasma concentrations of these substrates.

Drug-Food Interactions

LATUDA should be taken with food (at least 350 calories independent of fat content) [see **ACTION AND CLINICAL PHARMACOLOGY**].

Grapefruit, grapefruit juice, and products containing grapefruit extract should be avoided during treatment with LATUDA because of the potential to inhibit CYP3A4.

Drug-Herb Interactions

Interactions with herbal products have not been studied.

Drug-Laboratory Interactions

Interactions with laboratory tests have not been identified.

Drug-Lifestyle Interactions

Alcohol/CNS Drugs

Given the primary CNS effects of LATUDA, caution should be used when it is taken in combination with other centrally acting drugs and alcohol.

Smoking Status

Based on *in vitro* studies utilizing human liver enzymes, LATUDA is not a substrate for CYP1A2; smoking is, therefore, not expected to have an effect on the pharmacokinetics of LATUDA.

DOSAGE AND ADMINISTRATION

Dosing Considerations

- LATUDA (lurasidone HCl) should be administered with food (at least 350 calories independent of fat content). The C_{max} of lurasidone is increased approximately 3-fold and the AUC is increased approximately 2-fold in the presence of food.
- Tablets should not be crushed or cut, they should be swallowed whole.

Recommended Dose and Dosage Adjustment

Schizophrenia

Adults

The recommended starting dose of LATUDA is 40 mg once daily. In placebo-controlled clinical trials, once daily doses of 40, 80, 120, and 160 mg were shown to be effective. Patients should be treated with the lowest effective dose that provides optimal clinical response and tolerability, which is expected to be 40 mg or 80 mg once daily for most patients. Doses above 80 mg may be considered for certain patients based on individual clinical judgement.

Doses below 40 mg have not been shown to be effective in patients with schizophrenia.

Adolescents

The recommended starting dose of LATUDA is 40 mg once daily. In a placebo-controlled clinical trial, LATUDA has been shown to be effective at doses of 40 mg per day and 80 mg per day. The maximum recommended dose is 80 mg per day. Patients should be treated with the lowest effective dose that provides optimal clinical response and tolerability. In the placebo-controlled clinical trial, no additional benefit was demonstrated for 80 mg over 40 mg.

The safety and efficacy of LATUDA during long term treatment has not been systematically evaluated in adolescent patients with schizophrenia. The physician who elects to use LATUDA for extended periods in adolescent patients with schizophrenia should periodically re-evaluate the long term usefulness of the drug for the individual patient.

Bipolar Depression

Adults

The recommended starting dose of LATUDA is 20 mg given once daily as monotherapy or as adjunctive therapy with lithium or valproate. In placebo-controlled trials, once daily doses in the range of 20 mg/day to 120 mg/day as monotherapy or as adjunctive therapy with lithium or valproate were studied. In the only study that compared different LATUDA dosage strengths, efficacy of LATUDA was demonstrated in both 20 mg-60mg/day and 80-120 mg/day dosage arms. No additional benefit however, was seen in the higher dose arm [See Part II: **CLINICAL TRIALS**]. Thus, a usual treatment dose range of 20 mg-60 mg/day as monotherapy or adjunctive therapy with lithium or valproate is recommended. As the incidence of certain adverse events increase with dose [see **ADVERSE REACTIONS**] patients should be treated with the lowest

effective dose of LATUDA.

In bipolar depression, the safety of doses above 120 mg/day has not been evaluated. In addition, the efficacy of doses below 20 mg/day has not been studied.

Children and Adolescents (13-17 years of age)

The recommended starting dose of LATUDA is 20 mg given once daily as monotherapy. Initial dose titration is not required. The efficacy of LATUDA has been established in a dose range of 20 mg per day to 80 mg per day as monotherapy. The maximum recommended dose is 80 mg per day.

Switching from Other Antipsychotics

There are no systematically collected data to specifically address switching patients from other antipsychotics to LATUDA or concerning concomitant administration with other antipsychotics. While immediate discontinuation of the previous antipsychotic treatment may be acceptable for some patients, more gradual discontinuation may be most appropriate for others. In all cases, the period of overlapping antipsychotic administration should be minimized.

Dosing Considerations for Special Populations

Geriatrics (>65 years of age):

LATUDA is not indicated in elderly patients with dementia [see **WARNINGS AND PRECAUTIONS, Serious Warnings and Precautions Box** and **Special Populations**].

The safety and efficacy of LATUDA in patients 65 years of age or older has not been established. Caution should, thus, be exercised with the use of LATUDA in the elderly patient, recognizing the more frequent hepatic, renal, central nervous system and cardiovascular dysfunctions, and more frequent use of concomitant medications in this population.

Pediatrics:

Schizophrenia

Safety and efficacy were evaluated in adolescent (13-17 years of age) patients with schizophrenia in one 6-week clinical trial. LATUDA is not indicated for the treatment of schizophrenia in adolescent patients under 15 years of age due to insufficient safety and efficacy data [see **ADVERSE REACTIONS, CLINICAL TRIALS, Schizophrenia, Adolescents**].

Bipolar depression

The safety and efficacy of LATUDA 20 to 80 mg/day for the treatment of bipolar depression in children and adolescents (10 to 17 years) was evaluated in a 6-week, placebo-controlled clinical study in 343 children and adolescents. LATUDA is not indicated for the treatment of depressive episodes in bipolar I disorder in patients less than 13 years of age due to insufficient safety and efficacy data [see **ADVERSE REACTIONS, CLINICAL TRIALS, Bipolar Depression, Children and Adolescents**].

Irritability Associated with Autistic Disorder

Efficacy was not demonstrated in a 6-week study evaluating LATUDA 20 mg/day and 60 mg/day for the treatment of pediatric patients 6 to 17 years of age with irritability associated with autistic disorder.

Gender and Race:

Dosage adjustments are not recommended on the basis of gender or race [see **ACTION AND CLINICAL PHARMACOLOGY**].

Renal Impairment:

Dose adjustment is recommended in moderate and severe renal impairment patients. Caution should be exercised when starting LATUDA in patients with renal impairment. The recommended starting dose is 20 mg. Patients should be treated with the lowest effective dose that provides optimal clinical response and tolerability, which is expected to be 20-40 mg once daily for most patients with moderate or severe renal function impairment. The dose should not exceed 80 mg/day in patients with moderate and severe renal impairment [see **ACTION AND CLINICAL PHARMACOLOGY**].

Hepatic Impairment:

Dose adjustment is recommended in moderate and severe hepatic impairment patients. Caution should be exercised when starting LATUDA in patients with hepatic impairment. The recommended starting dose is 20 mg. Patients should be treated with the lowest effective dose that provides optimal clinical response and tolerability, which is expected to be 20-40 mg once daily for most patients with moderate or severe hepatic impairment (Child Pugh Class B and C). The dose in these patients should not exceed 40 mg/day in patients with severe hepatic impairment, and 80 mg/day in patients with moderate hepatic impairment [see **ACTION AND CLINICAL PHARMACOLOGY**].

Patients taking LATUDA Concomitantly with Potential CYP3A4 Inhibitors:

When coadministration of LATUDA with a moderate CYP3A4 inhibitor, such as diltiazem, is considered, LATUDA should be started at a dose of 20 mg/day, and the dose should not exceed 40 mg/day. LATUDA is contraindicated in combination with a strong CYP3A4 inhibitor (e.g., ketoconazole) [see **CONTRAINDICATIONS** and **DRUG INTERACTIONS**].

Patients taking LATUDA Concomitantly with Potential CYP3A4 Inducers:

LATUDA is contraindicated in combination with a strong CYP3A4 inducer (e.g., rifampin) [see **CONTRAINDICATIONS** and **DRUG INTERACTIONS**].

Administration

LATUDA should be administered with food (at least 350 calories independent of fat content). The C_{max} of lurasidone is increased approximately 3-fold and the AUC is increased approximately 2-fold in the presence of food.

OVERDOSAGE

Human Experience

In pre-marketing clinical studies, accidental or intentional overdosage of LATUDA (lurasidone HCl) was identified in one patient who ingested an estimated 560 mg of LATUDA. This patient recovered without sequelae. This patient resumed LATUDA treatment for an additional two months.

Management of Overdosage

There is no specific antidote to LATUDA, therefore, appropriate supportive measures should be instituted and close medical supervision and monitoring should continue until the patient recovers.

Cardiovascular monitoring should commence immediately, including continuous electrocardiographic monitoring for possible arrhythmias. If antiarrhythmic therapy is administered, disopyramide, procainamide, and quinidine carry a theoretical hazard of additive QT-prolonging effects when administered in patients with an acute overdose of LATUDA. Similarly the alpha-blocking properties of bretylium might be additive to those of LATUDA, resulting in problematic hypotension.

Hypotension and circulatory collapse should be treated with appropriate measures. Epinephrine and dopamine should not be used, or other sympathomimetics with beta-agonist activity, since beta stimulation may worsen hypotension in the setting of LATUDA-induced alpha blockade. In case of severe extrapyramidal symptoms, anticholinergic medication should be administered.

Gastric lavage (after intubation if patient is unconscious) and administration of activated charcoal together with a laxative should be considered.

The possibility of obtundation, seizures, or dystonic reaction of the head and neck following overdose may create a risk of aspiration with induced emesis.

For management of a suspected drug overdose, contact your regional Poison Control Centre.

ACTION AND CLINICAL PHARMACOLOGY

Mechanism of Action

The mechanism of action of lurasidone, as with other drugs having efficacy in schizophrenia and bipolar depression, is unknown. It has been suggested that the efficacy of lurasidone in schizophrenia and bipolar depression could be mediated through a combination of central dopamine Type 2 (D₂) and serotonin Type 2 (5HT_{2A}) receptor antagonism.

Pharmacodynamics

In vitro receptor binding studies revealed that lurasidone is an antagonist with high affinity at dopamine D₂ receptors (K_i = 0.994 nM), the 5-hydroxytryptamine (5-HT, serotonin) receptors 5-HT_{2A} (K_i = 0.47 nM), and 5-HT₇ (K_i = 0.495 nM); is an antagonist with moderate affinity at α_{2C} adrenergic receptors (K_i = 10.8) and α_{2A} adrenergic receptors (K_i = 40.7 nM), α₁ adrenergic receptors (K_i = 47.9 nM) and is a partial agonist with moderate affinity at serotonin 5-HT_{1A} (K_i = 6.38 nM) receptors.. Lurasidone exhibits little or no affinity for histamine H₁ and muscarinic M₁ receptors (IC₅₀ >1,000 nM).

Pharmacokinetics

Adults

The activity of lurasidone is primarily due to the parent drug. The pharmacokinetics of lurasidone are dose-proportional within a total daily dose range of 20 mg to 160 mg. Steady state concentrations of lurasidone are reached within 7 days of starting LATUDA (lurasidone HCl). Following administration of 40 mg of LATUDA, the mean (%CV) elimination half-life was 18 (7) hours.

Absorption

Lurasidone is absorbed and reaches peak serum concentrations in approximately 1-3 hours. It is estimated that 9-19% of an administered dose is absorbed.

In a food effect study, lurasidone mean C_{max} and AUC were about 3-times and 2-times, respectively, when administered with food compared to the levels observed under fasting conditions. Lurasidone exposure was not affected as meal size was increased from 350 to 1000 calories and was independent of meal fat content.

In clinical studies, establishing the safety and efficacy of LATUDA, patients were instructed to take their daily dose with food.

Distribution

Following administration of 40 mg of LATUDA, the mean (%CV) apparent volume of distribution was 6173 (17.2) L. Lurasidone is highly bound (~99%) to serum proteins.

Metabolism

Lurasidone is metabolized mainly via CYP3A4 enzyme. The major biotransformation pathways are oxidative N-dealkylation, hydroxylation of norbornane ring, and S-oxidation. Lurasidone is metabolized into two active metabolites (ID-14283 and ID-14326) and two major non-active metabolites (ID-20219 and ID-20220).

Excretion

Total excretion of radioactivity in urine and feces combined was approximately 89%, with about 80% recovered in feces and 9% recovered in urine, after a single dose of [¹⁴C]-labeled lurasidone.

Following administration of 40 mg of LATUDA, the mean (%CV) apparent clearance was 3902

(18.0) mL/min.

Adolescents

The pharmacokinetics of lurasidone in child and adolescent patients (10 to 17 years of age) were similar to those in adults. There were no clinically relevant differences between genders in the pharmacokinetics of lurasidone in patients with schizophrenia and bipolar I disorder.

Transporter Proteins

Lurasidone is an *in vitro* substrate of the efflux transporters P-gp and BCRP. Lurasidone is not subject to active uptake transport by OATP1B1 or OATP1B3.

Lurasidone is an inhibitor of P-gp, BCRP and OCT1 *in vitro*. Lurasidone is not expected to have a clinically relevant inhibitory potential on transporters OATP1B1, OATP1B3, OCT2, OAT1, OAT3, MATE1, MATE2K or BSEP based on *in vitro* data.

Special Populations and Conditions

Geriatrics

In elderly patients with psychosis (65 to 85), lurasidone concentrations (20 mg/day) were, on average, similar to those in young subjects [see also **WARNINGS AND PRECAUTIONS, Special Populations, Geriatrics**].

Gender

Population pharmacokinetic evaluation indicated that the mean AUC of LATUDA was 18% higher in women than in men, and correspondingly, the apparent oral clearance of LATUDA was lower in women. Mean C_{max} of LATUDA was similar between women and men. No dosage adjustment is recommended based on gender.

Race

Although no specific pharmacokinetic study was conducted to investigate the effects of race on the disposition of LATUDA, population pharmacokinetic evaluation revealed no evidence of clinically significant race-related differences in the pharmacokinetics of LATUDA. No dosage adjustment is recommended based on race.

Hepatic Insufficiency

Dose adjustment is recommended in patients with moderate or severe hepatic impairment. The recommended starting dose is 20 mg. Patients should be treated with the lowest effective dose that provides optimal clinical response and tolerability, which is expected to be 20-40 mg once daily for most patients with moderate or severe hepatic impairment (Child Pugh Class B and C). The dose should not exceed 40 mg/day in patients with severe hepatic impairment (Child-Pugh Class C), and 80 mg/day in patients with moderate hepatic impairment (Child-Pugh Class B). In a single-dose study of LATUDA 20 mg, lurasidone AUC_{0-last} was 1.5-times higher in subjects with mild hepatic impairment (Child-Pugh Class A), 1.7-times higher in subjects with moderate hepatic impairment (Child-Pugh Class B), and 3-times higher in subjects with severe hepatic impairment (Child-Pugh Class C) compared to the values for healthy matched subjects. Mean C_{max} was 1.3, 1.2, and 1.3-times higher for mild, moderate, and severe hepatically impaired patients,

respectively, compared to the values for healthy matched subjects.

Renal Insufficiency

Dose adjustment is recommended in patients with moderate or severe renal function impairment. The recommended starting dose is 20 mg. Patients should be treated with the lowest effective dose that provides optimal clinical response and tolerability, which is expected to be 20-40 mg once daily for most patients with moderate and severe renal impairment ($Cl_{cr} \geq 10$ mL/min to < 50 mL/min). The dose should not exceed 80 mg/day in patients with moderate and severe renal impairment. After administration of a single dose of 40 mg LATUDA to patients with mild, moderate, and severe renal impairment, mean C_{max} increased by 40%, 92%, and 54%, respectively, and mean $AUC_{(0-\infty)}$ increased by 53%, 91%, and 2- times, respectively, compared to healthy matched subjects.

Smoking Status

Based on *in vitro* studies utilizing human liver enzymes, LATUDA is not a substrate for CYP1A2; smoking is therefore not expected to have an effect on the pharmacokinetics of LATUDA.

STORAGE AND STABILITY

Store LATUDA (lurasidone HCl) tablets at 15° - 30°C.

SPECIAL HANDLING INSTRUCTIONS

None.

DOSAGE FORMS, COMPOSITION AND PACKAGING

LATUDA (lurasidone HCl) tablets are white to off-white, round (20 mg and 40 mg), white to off-white, capsule shaped (60 mg), pale green, oval (80 mg), or white to off-white, oval (120 mg) and identified with strength-specific one-sided debossing, “L20” (20 mg), “L40” (40 mg), “L60” (60mg), “L80” (80 mg), or “L120” (120 mg).

Each tablet contains 20 mg, 40 mg, 60 mg, 80 mg, or 120 mg of lurasidone hydrochloride. Inactive ingredients are mannitol, pregelatinized starch, croscarmellose sodium, hypromellose, magnesium stearate, Opadry® (hypromellose, titanium dioxide, and polyethylene glycol), and carnauba wax. Additionally, the 80 mg tablet contains yellow ferric oxide and FD&C Blue No.2 Aluminum Lake.

Tablets are supplied in bottles of 30 tablets and boxes of 28 (Physician Samples - 4 blister cards, 7 tablets each).

PART II: SCIENTIFIC INFORMATION

PHARMACEUTICAL INFORMATION

Drug Substance

Proper name: lurasidone hydrochloride

Chemical name: (3*aR*,4*S*,7*R*,7*aS*)-2-{(1*R*,2*R*)-2-[4-(1,2-benzisothiazol-3-yl)piperazin-1-ylmethyl]cyclohexylmethyl}hexahydro-4,7-methano-2*H*-isoindole-1,3-dione hydrochloride

Molecular formula and molecular mass: $C_{28}H_{36}N_4O_2S \cdot HCl$
M.W: 529.14

Structural formula:

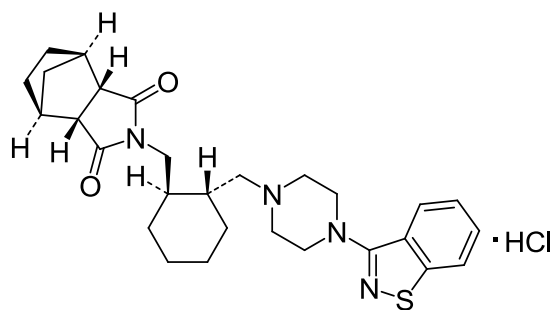

Physicochemical properties: White to off-white powder
Very slightly soluble in water
Practically insoluble or insoluble in 0.1 N HCl
Slightly soluble in ethanol
Sparingly soluble in methanol
Practically insoluble or insoluble in toluene
Very slightly soluble in acetone

CLINICAL TRIALS

Schizophrenia

Adults

Study Demographics and Trial Design

The efficacy of LATUDA for the treatment of schizophrenia was established in five short-term (6-week), placebo-controlled studies in adult patients (mean age of 38.4 years, range 18-72) who met DSM-IV criteria for schizophrenia. An active control arm (olanzapine or quetiapine XR) was included in two studies to assess assay sensitivity; the studies were not designed to compare LATUDA to the active comparators. In four of the five short-term studies, the study drug was administered once daily in the morning with a meal or within 30 minutes after eating, although evening dosing was permitted with Medical Monitor approval. In the fifth study, comparing LATUDA 80 mg and 160 mg doses and quetiapine XR 600 mg dose to placebo, the study drug was administered once daily in the evening with a meal or within 30 minutes after eating and efficacy and safety assessments were performed the next morning.

In two additional short-term (6-week), placebo-controlled studies, neither LATUDA (20 mg, 40 mg, or 80 mg) nor the active comparators (haloperidol 10 mg/day or risperidone 4 mg/day) showed superiority to placebo in the primary efficacy outcome, and thus were considered failed studies.

Several instruments were used for assessing psychiatric signs and symptoms in these studies:

1. Positive and Negative Syndrome Scale (PANSS) is a multi-item inventory of general psychopathology used to evaluate the effects of drug treatment in schizophrenia. PANSS total scores may range from 30 to 210.
2. Brief Psychiatric Rating Scale derived (BPRSd), derived from the PANSS, is a multi-item inventory primarily focusing on positive symptoms of schizophrenia, whereas the PANSS includes a wider range of positive, negative, and other symptoms of schizophrenia. BPRSd scores may range from 18 to 126.
3. The Clinical Global Impression severity scale (CGI-S) is a validated clinician-rated scale that measures the subject's current illness state on a 1 to 7-point scale.

The endpoint associated with each instrument is change from baseline in the total score to the end of week 6. These changes are then compared to placebo changes for the drug and control groups.

Study Results

The results of the positive studies follow:

1. In a 6-week, placebo-controlled trial (N=145) involving two fixed doses of LATUDA (40 or 120 mg/day), both doses of LATUDA at Endpoint were superior to placebo on the BPRSd total score and the CGI-S score.
2. In a 6-week, placebo-controlled trial (N=180) involving a fixed dose of LATUDA (80 mg/day), LATUDA at Endpoint was superior to placebo on the BPRSd total score and the CGI-S score.
3. In a 6-week, placebo and active-controlled trial (N=473) involving two fixed doses of LATUDA (40 or 120 mg/day) and an active control (olanzapine) to assess study assay sensitivity, both LATUDA doses and the active control at Endpoint were superior to placebo on the PANSS total score and the CGI-S score.
4. In a 6-week, placebo-controlled trial (N=489) involving three fixed doses of LATUDA (40, 80, or 120 mg/day), only the 80 mg/day dose of LATUDA at Endpoint was superior to placebo on the PANSS total score and the CGI-S score.
5. In a 6-week, placebo, and active-controlled trial (N=482) involving two fixed doses of LATUDA (80 or 160 mg/day) and an active control (quetiapine XR) to assess study assay sensitivity, both LATUDA doses and the active control at Endpoint were superior to placebo on the PANSS total score and the CGI-S score.

Adolescents

The efficacy of LATUDA in the treatment of schizophrenia in adolescent patients (13 to 17 years of age) was evaluated in one 6-week, placebo-controlled study of patients (N=326) who met DSM-IV criteria for schizophrenia. The majority of patients (72%) included in the trial were 15 to 17 years of age.

Patients were randomized to placebo or fixed doses of LATUDA (40 mg or 80 mg). The primary efficacy endpoint was the change from Baseline in the Positive and Negative Syndrome Scale (PANSS) Total Score at Week 6.

Both the 40 mg and 80 mg doses of lurasidone demonstrated superiority over placebo on the PANSS total score after 6 weeks of double-blind treatment (Table 36). The 80 mg dose was not shown to be more efficacious than the 40 mg dose.

Table 36: Primary Efficacy Results for Study in Adolescent Schizophrenia (PANSS Total Score)

Treatment Group	Primary Efficacy Measure: PANSS		
	Mean Baseline Score (SD)	LS Mean Change from Baseline (SE)	Placebo-subtracted Difference ^a (95% CI)
LATUDA (40 mg/day)*	94.5 (10.97)	-18.6 (1.59)	-8.0 (-12.4, -3.7)
LATUDA (80 mg/day)*	94.0 (11.12)	-18.3 (1.60)	-7.7 (-12.1, -3.4)
Placebo	92.8 (11.08)	-10.5 (1.59)	--

SD: standard deviation; SE: standard error; LS Mean: least-squares mean; CI: confidence interval, unadjusted for multiple comparisons.

^a Difference (drug minus placebo) in least-squares mean change from baseline.

* Doses statistically significantly superior to placebo.

Bipolar Depression

Adults

Study Demographics and Trial Design

Monotherapy

The efficacy of LATUDA, as monotherapy, was established in a 6-week, randomized, double-blind, placebo-controlled study of adult patients (mean age of 41.5 years, range 18-74) who met DSM-IV-TR criteria for depressive episodes associated with bipolar I disorder, with or without rapid cycling, and without psychotic features (N=485). Patients were randomized to flexibly dosed LATUDA 20-60 mg/day, LATUDA 80-120 mg/day or placebo. Primary and key secondary efficacy assessments were conducted at baseline and Weeks 1 through 6.

The primary rating instrument used to assess depressive symptoms in this study was the Montgomery-Asberg Depression Rating Scale (MADRS), a 10-item clinician-rated scale with total scores ranging from 0 (no depressive features) to 60 (maximum score). The primary endpoint was the change from baseline in MADRS score at Week 6. The key secondary instrument was the Clinical Global Impression-Bipolar-Severity of Illness scale (CGI-BP-S), a clinician-rated scale that measures the subject's current illness state on a 7-point scale, where a higher score is associated with greater illness severity.

Adjunctive Therapy

The efficacy of LATUDA, as an adjunctive therapy to lithium or valproate, was evaluated in two (N=340 and 342) 6-week, randomized, double-blind, placebo-controlled studies of adult patients (mean age of 42.6 years, range 18-74) who met DSM-IV-TR criteria for depressive episodes associated with bipolar I disorder, with or without rapid cycling, and without psychotic features. Patients who remained symptomatic during treatment with lithium or valproate were randomized to flexibly dosed LATUDA 20-120 mg/day or placebo. Primary and key secondary efficacy assessments were conducted at baseline and Weeks 1 through 6.

The primary rating instrument used to assess depressive symptoms in this study was the MADRS. The primary endpoint was the change from baseline in MADRS score at Week 6. The key secondary instrument was the CGI-BP-S scale.

Study Results

Monotherapy

LATUDA was superior to placebo in reduction of MADRS and CGI-BP-S scores at Week 6. The high dose group (80-120 mg) did not provide improved efficacy on average compared to the low dose group (20-60 mg). Significant treatment differences in MADRS and CGI-BP-S were observed at Week 2 for LATUDA 20-60 mg which were sustained for the remainder of the study. The proportion of patients with $\geq 50\%$ improvement in MADRS was significantly greater ($p < 0.001$) in both LATUDA flexible-dose groups (53% LATUDA 20-60 mg; 51% LATUDA 80-120 mg) vs. placebo (30%). Both LATUDA dose groups were associated with significantly greater improvement than placebo on seven of the 10 MADRS items ($p < 0.05$). The secondary endpoints supported the superiority of LATUDA over placebo.

Adjunctive Therapy

In one study, LATUDA was superior to placebo in reduction of MADRS and CGI-BP-S scores as an adjunctive therapy to lithium or valproate at Week 6. Significant treatment differences were observed in the LATUDA + lithium or valproate dose group at Week 3 in MADRS and at Week 2 in the CGI-BP-S which were sustained for the remainder of the study. The proportion of patients with $\geq 50\%$ improvement in MADRS was significantly greater ($p = 0.008$) in the LATUDA + lithium or valproate dose group (57%) vs. placebo (42%). LATUDA was associated with significantly greater improvement than placebo on six of the 10 MADRS items ($p < 0.05$). The secondary endpoints supported the superiority of LATUDA over placebo.

In a second study, a statistically significant difference was not demonstrated between LATUDA and placebo for the primary endpoint (MADRS) at Week 6.

Children and Adolescents

The efficacy of LATUDA was evaluated in a 6-week, multicenter, randomized, double-blind, placebo-controlled study of children and adolescents (10 to 17 years) who met DSM-V criteria for major depressive episodes associated with bipolar I disorder, with or without rapid cycling, and without psychotic features (N=343). The majority (78%) of patients were 13 years of age or older. Patients were randomized to flexibly dosed LATUDA 20 to 80 mg/day or placebo.

The primary rating scale used to assess depressive symptoms in this study was the Children's Depression Rating Scale, Revised (CDRS-R) total score. The primary endpoint was the change from baseline in CDRS-R score at Week 6.

LATUDA was superior to placebo in reduction of CDRS-R total score at Week 6. The primary efficacy results are provided in Table 37.

Table 37: Primary Efficacy Results for the Children and Adolescents Study in Depressive Episodes Associated with Bipolar I Disorder (CDRS-R Total Score)

Treatment Group	Primary Efficacy Measure: CDRS-R		
	Mean Baseline Score (SD)	LS Mean Change from Baseline (SE)	Placebo-subtracted Difference ^a (95% CI)
LATUDA (20 to 80 mg/day)*	59.2 (8.24)	-21.0 (1.06)	-5.7 (-8.4,-3.0)
Placebo	58.6 (8.26)	-15.3 (1.08)	--

SD: standard deviation; SE: standard error; LS Mean: least-squares mean; CI: confidence interval, unadjusted for multiple comparisons.

^a Difference (drug minus placebo) in least-squares mean change from baseline.

* Treatment group statistically significantly superior to placebo.

DETAILED PHARMACOLOGY

Nonclinical Pharmacodynamics

Receptor Binding

In vitro receptor binding studies revealed that lurasidone is an antagonist with high affinity at dopamine D₂ receptors (K_i = 0.994 nM), D_{2L} receptors (K_i = 0.329 and 0.994 nM), and the 5-hydroxytryptamine (5-HT, serotonin) receptors 5-HT_{2A} (K_i = 0.47 nM) and 5-HT₇ (K_i = 0.495 nM), is an antagonist with moderate affinity at human α_{2C} adrenergic receptors (K_i = 10.8 nM), is a partial agonist at serotonin 5-HT_{1A} (K_i = 6.38 nM) receptors, and is an antagonist at α_{2A} adrenergic receptors (K_i = 40.7 nM). Lurasidone exhibits little or no affinity for histamine H₁ and muscarinic M₁ receptors (IC₅₀ > 1,000 nM).

Schizophrenia

Pharmacological studies have shown that lurasidone was effective in various animal models of schizophrenia induced by methamphetamine or tryptamine, and confirmed its potent dopamine D₂-blocking and serotonin 5-HT₂-blocking actions.

Bipolar Depression

Pharmacological studies have shown that lurasidone was effective in some animal models of depression.

Effects on the Central Nervous System

Lurasidone, when intravenously administered at high doses, slowed spontaneous electroencephalogram (EEG) in rabbits, and inhibited emetic response in apomorphine-treated dogs following oral administration, but exerted no other potent effects on the CNS (anti-acetylcholine action, anti-hypoxic action, effects on cerebral blood flow, convulsion facilitating action, and anti-adrenergic action).

Lurasidone demonstrated mild anti-histamine and anti-noradrenaline effects but not anti-acetylcholine effect in *in vitro* studies.

Effects on Cardiovascular System

In addition to the animal studies of antipsychotic efficacy and mechanism of action, a safety pharmacological evaluation of lurasidone was conducted to obtain a more extensive characterization of its actions on various organ systems *in vitro* and *in vivo*. Potential cardiovascular effects were assessed in *in vitro* and *in vivo* safety pharmacology and toxicology studies. In HEK293 cells stably expressing the hERG gene, lurasidone and its metabolites, ID-14326 and ID-14283, caused concentration-dependent suppression of hERG currents with IC50 values of 57 ng/mL, 357 ng/mL, and 434 ng/mL, respectively. There were no effects on action potential duration (APD) in guinea pig papillary muscle and on inotropic/chronotropic action in guinea pig atrium.

Conscious telemetered female dogs (N=4/treatment) received single oral doses of vehicle, lurasidone 100 mg/kg, lurasidone 300 mg/kg, or sotalol according to Latin square crossover design. Lurasidone 100 mg/kg and 300 mg/kg caused statistically significant increases in heart rate. Lurasidone 300 mg/kg also caused a statistically significant increase in the QTc interval. C_{max} values were reported to be 1.9 µg/mL for lurasidone 100 mg/kg and 2.8 µg/mL for lurasidone 300 mg/kg. In a 39-week, repeated oral doses toxicology study in dogs, lurasidone showed QTc prolongation in 1 out of 4 male dogs in the 100 mg/kg group and 2 out of 4 male dogs in the 200 mg/kg group. QT prolongation effect of lurasidone in dogs arises at 12- to 20-fold higher plasma levels than the plasma C_{max} associated with the maximum dose evaluated in clinical trials.

Nonclinical Pharmacokinetics

The pharmacokinetic parameters (absorption, distribution, metabolism, and excretion) of lurasidone have been studied in mice, rats, dogs, rabbits, and monkeys.

Lurasidone is rapidly absorbed with peak systemic exposure occurring within 5.3 hours of administration. The absolute bioavailability is low, <12%, in all species examined. Administration of lurasidone with food increases the extent of absorption two- to three-fold. Clearance ranged from 17 to 61 mL/min/kg and volume of distribution ranged from 2.4 to 20 L/kg. Terminal elimination half-life is also variable, ranging from 1.6 to 27 hours.

Lurasidone binds extensively (>99% bound) to serum proteins including human serum albumin and α-glycoprotein. Distribution into red blood cells is moderate with blood:plasma ratios ranging from 0.57 – 0.80. Lurasidone distributes into most tissues including the brain and into the fetus.

Lurasidone is extensively metabolized with oxidative *N*-dealkylation, hydroxylation of the norbornane ring or cyclohexane ring, *S*-oxidation, reductive cleavage of the isothiazole ring followed by *S*-methylation, and a combination of two or more of these pathways. Although many metabolites were found in human serum, all primary metabolites were detected in one or more of the nonclinical animal species; therefore, no human specific metabolites have been identified.

The primary metabolizing Cytochrome P450 (CYP) isozyme in humans is CYP3A4. Specific metabolizing isozymes in nonclinical species have not been identified. *In vitro* studies conducted with human tissue preparations suggest that at clinically relevant concentrations lurasidone does not inhibit or induce CYP enzyme activity. The potential for protein-based clinical drug-drug interactions appears to be minimal as no displacement of lurasidone or co-incubated drugs from serum proteins is observed *in vitro*. Lurasidone is an *in vitro* substrate of P-glycoprotein (P-gp) and BCRP, and an inhibitor of P-gp, BCRP and OCT1 *in vitro*.

Following administration of [¹⁴C]lurasidone, the majority of the radioactivity was excreted in feces as parent compound. Approximately 12-48% of the orally administered dose was absorbed. Unchanged parent compound is detected only at trace levels in bile and urine, indicating that the absorbed material is subject to extensive metabolism. Lurasidone is excreted into rat milk primarily as unchanged drug at concentrations that are greater than those in serum.

TOXICOLOGY

Single-Dose Toxicity

In single-dose studies performed in rats and monkeys, there were no deaths at the highest dose levels of 2000 mg/kg in either species. The target organ for acute toxicity is the CNS. Clinical signs in rats consisted of decreased spontaneous activity, ptosis, and decreased body weight and/or body weight gain at ≥ 1000 mg/kg and ataxic gait at 2000 mg/kg. Treatment-related clinical signs in monkeys included decrease of spontaneous activity in all treated groups (10 to 2000 mg/kg), tremor, and decrease of spontaneous activity accompanied by extrapyramidal symptoms such as persistent abnormal posture and slow movement at 50 mg/kg or higher, closed eyelids at 250 mg/kg, and miosis, closed eyelids, and vomiting at 2000 mg/kg. Food consumption was reduced at 250 mg/kg or higher.

Serum concentrations of lurasidone and prolactin were evaluated after a single oral dose of lurasidone at levels up to 1000 mg/kg in rats. The concentrations of serum prolactin at one (peak level) and two hours after administration, at almost all doses of 10 mg/kg and above, were significantly higher (up to 44-fold control levels) or tended to be higher than the control values, with little or no dose dependency. The increases in peak serum levels and total exposure of lurasidone were dose-dependent up to 500 mg/kg in male rats and up to 1000 mg/kg in female rats.

Repeat-Dose Toxicity

Repeat-dose toxicity studies from 2 to 52 weeks in duration were performed in mice, rats, dogs, and monkeys.

Toxic responses to orally administered lurasidone were rapid in onset. The main target organs of toxicity are the CNS and the endocrine system. Like other antipsychotic drugs that bind to dopamine D2 receptors, lurasidone has been shown to elevate serum prolactin levels in mice, rats, dogs, and monkeys.

Clinical signs evident after repeated doses included decreased spontaneous activity and extrapyramidal effects in rats, dogs, and monkeys. Prolactin-related effects were similar in rodents and dogs regarding histopathologic changes in the mammary glands. Mild signs of mammary development (1 female) and lactogenesis (1 female) were observed in monkeys. Prostatic changes were observed only in dogs, vaginal changes were observed only in rodents, whereas pituitary changes were seen in rodents and monkeys. Prolactin-related fatty infiltration into bone marrow and reduced bone density were seen in rats, but were not observed in mice. Similar changes were seen in a few high-dose dogs that were suffering from emaciation, but which were considered secondary effects of increased corticosteroid secretion in response to the stress of their condition.

Cardiac effects were not determined in the mouse and rat, and were not seen in the monkey at any dose level, but QT prolongation and/or PVC were observed in the dog toxicology studies. Signs of anemia were observed in the 4-week dog study but not in the 39-week study. Except for some of the effects on bone, these clinical signs resolved upon withdrawal of treatment and are considered to represent exaggerated pharmacology of the drug, relating mostly to hyperprolactinemia, or CNS and cardiovascular effects, all commonly seen with D₂ receptor antagonist antipsychotic agents. The dosing regimens used in the various repeated-dose studies consisted of once-daily administration by oral gavage in mice, rats, and dogs, and by intranasal gastric gavage in monkeys. In each case the vehicle was 0.5% aqueous methylcellulose.

Mouse Study

All dose levels in the 3-month mouse study (25 to 500 mg/kg/day) produced adverse effects, consisting mainly of decreased spontaneous activity, and effects on female sex organs that were attributed to increased prolactin levels. The NOAEL is less than 25 mg/kg/day for repeated dosing in this species, and the corresponding safety margins for these effects, relative to man at the MRHD of 160 mg/day, are less than 0.38 (males) or less than 0.64 (females) from comparisons based upon peak serum exposure levels of lurasidone, and less than 0.37 (males) or less than 0.60 (females) based upon total serum exposure levels of lurasidone.

Rat Studies

The 90-day NOAEL in male and female rats is 0.3 and 0.1 mg/kg/day, respectively, based upon the combined results of the two 3-month studies performed in Sprague-Dawley rats. The safety margins, based upon peak serum levels relative to man at the MRHD, are 0.005 and 0.001, respectively. Based upon the results of the 6-month study, the NOAEL in rats of either sex is 0.03 mg/kg/day. Dosage administration at levels at or above 1 mg/kg/day for 6 months produced changes in male mammary glands and elevated hemoglobin concentrations, along with elevated prolactin levels. Adverse effects seen in females at these same dose levels included effects on female sex organs and increased incidence of fatty infiltration into the femur marrow, thickened zona glomerulosa of adrenal, and decreased total bone mineral density of femur. The resultant safety margin, based upon peak serum levels relative to man at the MRHD, are 0.0006 and 0.0003, for males and females, respectively.

Dog Studies

All dose levels in both the 4-week and 39-week repeated-dose studies in the Beagle dog produced adverse effects attributed to increased prolactin levels. Both studies utilized 30 mg/kg/day as the lowest dose. In the 4-week study, a 30 mg/kg/day dose produced effects in the thymus and

mammary glands. The same dose level in the 39-week study also produced effects on the thymus in males, but more severe mammary effects as well as changes in the uterus and ovary in females and in the prostate of males. All dose levels produced CNS effects (decreased spontaneous activity, tremors, miosis, and somnolence). Thymic atrophy or involution were seen in both dog studies, and increased total cholesterol and phospholipids as well as increased cytoplasmic eosinophilic granule epithelium in urinary bladder were observed at or above 30 mg/kg/day in the 39-week study. The NOAEL is less than 30 mg/kg/day for repeated dosing of lurasidone in the dog, and the corresponding safety margins for these effects, relative to man at the MRHD of 160 mg/day, are less than 3.4 (4 weeks) or less than 4.9 (39 weeks) based upon peak serum levels of lurasidone and less than 3.1 (4 weeks) or less than 11/9.2 (M/F, 39 weeks) based upon total exposure levels.

Monkey Studies

There were no significant prolactin-related adverse effects in the 3-month and 1-year repeated-dose studies in *Cynomolgus* monkeys. The observations of decreased spontaneous activity, movement disorder, and abnormal posture were considered CNS effects and not directly related to prolactin levels. The only minor finding that was possibly related to prolactin was the presence of enlarged pale staining cells in the pituitary, which were observed upon histopathologic examination in both sexes at 50 mg/kg/day in the 1-year study. Mean serum prolactin concentrations at 4 hours after dosing were increased in a dose-related fashion in all treated groups in both studies.

If one considers the elevation of prolactin levels as a non-adverse effect, the CNS effects observed at 10 and 2 mg/kg/day in the 3-month and 1-year monkey studies, respectively, put the NOAEL for monkeys near 2 mg/kg/day. Safety margins (1-year study) at the MRHD were 0.01 to 0.03 (based on C_{max}) and 0.02 to 0.03 (based on AUC).

Reproductive and Developmental Toxicity

Lurasidone was administered orally to female rats at doses of 0.1, 1.5, 15, or 150 mg/kg/day for 15 consecutive days prior to mating, during the mating period, and through day 7 of gestation. Estrus cycle irregularities were seen at 1.5 mg/kg and above; the no-effect dose of 0.1 mg/kg is approximately 0.006 times the maximum recommended human dose (MRHD) of 160 mg/day based on body surface area. Fertility was reduced only at the highest dose and this was shown to be reversible after a 14 day drug-free period. The no-effect dose for reduced fertility was 15 mg/kg, which is 0.9 times the MRHD based on body surface area.

Fertility was not affected in male rats treated orally with lurasidone for 64 consecutive days prior to mating and during the mating period at doses up to 150 mg/kg/day (9 times the MRHD based on body surface area).

No teratogenic effects were seen in studies in which pregnant rats and rabbits were given lurasidone during the period of organogenesis at doses up to 25 and 50 mg/kg/day, respectively. These doses produced plasma levels (AUC) 3.7 and 0.6 times, in rats and rabbits, respectively, the MRHD based upon total exposure.

No adverse developmental effects were seen in a study in which pregnant rats were given lurasidone during the period of organogenesis and continuing through weaning at doses up to 10 mg/kg/day; this dose produced plasma levels (AUC) 1.3 times those in humans receiving the MRHD.

Juvenile Animal Studies

Lurasidone oral administration to juvenile rats at doses of 3, 30, and 150 (males) or 300 (females) mg/kg/day which are 0.7 to 22 times (males) and 0.6 to 63 times (females) plasma levels (AUC) in pediatric/adolescent patients receiving the MRHD of 80 mg/day, from postnatal day (PND) 21 through PND 91 (the period corresponding to childhood, adolescence, and young adulthood) resulted in growth and developmental delays in both genders at 30 mg/kg/day and higher.

The NOAEL for juvenile rats' physical growth and development is 3 mg/kg/day (0.7 times (males) and 0.6 times (females) the MRHD based upon total exposure. Lurasidone effects included dose-dependent decreases in tibial length, bone mineral content, body and brain weights starting at 30 mg/kg/day in both sexes, and delay in attainment of sexual maturity in males at 150 mg/kg/day and in females starting at 30 mg/kg/day. The delay in attainment of sexual maturity in females was associated with decreased serum estradiol and may have been also exacerbated by lower mean body weight. Mortality occurred during early post-weaning period at 30 mg/kg/day (males only) and higher doses (both sexes) on PND 22, 23 or 24. Systemic exposures at the LOEL for these findings (30 mg/kg/day) in males and females were 11 times and 14 times the MRHD based upon total exposure.

The NOAEL for lurasidone HCl neurobehavioral effect was 3 mg/kg/day in males and <3 mg/kg/day in females. Hyperactivity was noted during the post-treatment period starting at 30 mg/kg/day in males and 3 mg/kg/day in females (11 and 7 times the MRHD, respectively, based upon total exposure) and was still present at the end of the post-treatment period.

Histopathological findings included increased colloid in the thyroids and inflammation of the prostate in males at 150 mg/kg/day (22 times the MRHD based upon total exposure), and mammary gland hyperplasia, increased mucification of the vagina, and increased ovarian atretic follicles in females at doses as low as 3 mg/kg/day (7 times the MRHD based upon total exposure). Some of these findings were attributed to transiently elevated serum prolactin which was seen in both sexes at all doses. However, there were no deviations in reproductive parameters (fertility, conception indices, spermatogenesis, estrous cycle, gestation length, parturition, number of pups born) at any dose level.

The NOAEL for the offspring of the treated juvenile animals was 3 mg/kg/day based on the lower birth weights and body weights/body weight gains during the postnatal period for the offspring of the treated juvenile animals at 30 and 300 mg/kg/day.

Carcinogenicity

Lifetime carcinogenicity studies were conducted in ICR mice and Sprague-Dawley rats. Lurasidone was administered orally at doses of 30, 100, 300, or 650 (the high dose was reduced

from 1200 in males) mg/kg/day to ICR mice and 3, 12, or 36 (high dose reduced from 50) mg/kg/day to Sprague-Dawley rats.

In the mouse study, there were increased incidences of malignant mammary gland tumors and pituitary gland adenomas in females at all doses; the lowest dose tested produced plasma levels (AUC) approximately equal to those in humans receiving the maximum recommended human dose (MRHD) of 160 mg/day. No increases in tumors were seen in male mice up to the highest dose tested, which produced plasma levels (AUC) 7 - 13 times those in humans receiving the MRHD.

In rats, an increased incidence of mammary gland carcinomas was seen in females at the two higher doses; the no-effect dose of 3 mg/kg produced plasma levels (AUC) 0.4 times those in humans receiving the MRHD. No increases in tumors were seen in male rats up to highest dose tested, which produced plasma levels (AUC) 6 times those in humans receiving the MRHD.

Mutagenesis

The potential for the genotoxicity of lurasidone has been adequately studied in varied test systems including *in vitro* assays in bacterial and mammalian cell systems (with and without metabolic activation) and in an *in vivo* micronucleus assay in mice. Lurasidone was shown not to be mutagenic or clastogenic under the conditions of these well-controlled assays.

Drug Dependence

The drug dependence studies in rats and monkeys did not indicate potential for lurasidone to induce psychic and physical dependence. Lurasidone was not self-administered by monkeys trained to self-administer barbiturate, did not suppress barbiturate withdrawal signs, and did not produce withdrawal signs after discontinuation of repeated dosing.

Antigenicity

Lurasidone caused delayed-type allergic reactions under strong sensitizing conditions in which it was subcutaneously administered at a dose 3 times the proposed clinical dose of 160 mg/day, along with Freund's complete adjuvant. However, as lurasidone did not show antigenicity in active systemic anaphylactic reaction assays, passive cutaneous anaphylactic reaction assays, or gel precipitation reaction nor on intradermal tests when orally administered, it is unlikely that lurasidone will show antigenicity when orally administered to humans.

Phototoxicity

Oral administration of lurasidone to rats prior to irradiation with ultraviolet A (UVA) radiation at a dose of 10 J/cm² produced no remarkable skin reaction or increase in ear thickness. It was concluded that lurasidone had no phototoxic effect on the skin under the conditions of the present study and is unlikely to show phototoxicity when orally administered to humans.

REFERENCES

DelBello M et al. Efficacy and Safety of Lurasidone in Children and Adolescents with Bipolar I Depression: A Double-Blind, Placebo-Controlled Study. *J Am Acad Child Adolesc Psychiatry* 2017;56(12):1015-1025.

Findling RL et al. Pharmacokinetics and Tolerability of Lurasidone in Children and Adolescents With Psychiatric Disorders. *Clin Ther* 2015;37(12):2788-2797.

Goldman R et al. Efficacy and Safety of Lurasidone in Adolescents with Schizophrenia: A 6-Week, Randomized Placebo-Controlled Study. *J Child Adolesc Psychopharmacol* 2017;27(6):516-525.

Loebel A et al. Efficacy and Safety of Lurasidone 80 mg/day and 160 mg/day in the Treatment of Schizophrenia: A Randomized, Double-Blind, Placebo- and Active-Controlled Trial. *Schizophrenia Research* 2013;145(1-3):101-109.

Loebel A et al. Lurasidone Monotherapy in the Treatment of Bipolar I Depression: A Randomized, Double-Blind, Placebo-Controlled Study. *Am J Psychiatry* 2014;171:160-168.

Loebel A et al. Lurasidone as Adjunctive Therapy with Lithium or Valproate for the Treatment of Bipolar I Depression: A Randomized, Double-Blind, Placebo-Controlled Study. *Am J Psychiatry* 2014;171:169-177.

Meltzer HY et al. Lurasidone in the Treatment of Schizophrenia: A Randomized, Double-Blind, Placebo- and Olanzapine-Controlled Study. *Am J Psychiatry* 2011;168:957-967.

Nasrallah HA et al. Lurasidone for the Treatment of Acutely Psychotic Patients with Schizophrenia: A 6-Week, Randomized, Placebo-Controlled Study. *Journal of Psychiatric Research* 2013;47:670-677.

Nakamura M et al. Lurasidone in the Treatment of Acute Schizophrenia: A Double-Blind, Placebo-Controlled Trial. *J Clin Psychiatry*. 2009;70(6):829-836.

Osaga M et al. Lurasidone in the Treatment of Schizophrenia: A 6-week, Placebo-Controlled Study. *Psychopharmacology* 2013;225:519-530.

PART III: CONSUMER INFORMATION

PrLATUDA®
lurasidone hydrochloride tablets

This leaflet is part III of a three-part "Product Monograph" published when LATUDA was approved for sale in Canada and is designed specifically for Consumers. This leaflet is a summary and will not tell you/the person you are caring for everything about LATUDA. Contact your doctor or pharmacist if you have any questions about the drug.

ABOUT THIS MEDICATION**What the medication is used for:**

LATUDA is used to treat the symptoms of schizophrenia in adults and in adolescents (15-17 years of age).

Schizophrenia is characterized by symptoms such as:

- hearing, seeing, or sensing things that are not there
- suspiciousness, mistaken beliefs
- incoherent speech and behavior, and
- emotional flatness.

People with this condition may also feel depressed, guilty, anxious, or tense.

LATUDA is also used to treat the symptoms of depression associated with bipolar disorder in adults and adolescents (13-17 years of age) such as:

- sadness
- loss of interest and enjoyment
- lack of energy
- change in appetite
- sleep disturbance, and
- difficulty concentrating.

LATUDA is not a cure for your condition, but it can help manage your symptoms.

Your doctor may have prescribed LATUDA for another reason.

Ask your doctor if you have any questions about why LATUDA has been prescribed for you.

A Reminder: This medicine has been prescribed only for you. Never give it to anyone else.

What it does:

LATUDA belongs to a group of medicines called atypical antipsychotics.

Antipsychotic medications affect the chemicals (neurotransmitters) that allow nerve cells to talk to each other. Two of the chemicals in the brain, called dopamine and serotonin, may be out of balance in schizophrenia or bipolar depression. It is not known exactly how LATUDA works. However, it seems to help keep the right balance of dopamine and serotonin in your brain.

When it should not be used:

Do not take LATUDA if you:

- are allergic to LATUDA or any of the ingredients in LATUDA
- are taking drugs that affect significantly the way LATUDA is broken down in your body:
 - a strong CYP3A4 inhibitor (such as ketoconazole)
 - a strong CYP3A4 inducer (such as rifampin)

What the medicinal ingredient is:

lurasidone hydrochloride

What the nonmedicinal ingredients are:

LATUDA contains the following nonmedicinal ingredients: carnauba wax, croscarmellose sodium, hypromellose, magnesium stearate, mannitol, Opadry® (hypromellose, polyethylene glycol, and titanium dioxide), pregelatinized starch; 80 mg tablet also contains: FD&C Blue No.2 Aluminum Lake and yellow ferric oxide.

What dosage forms it comes in:

20 mg, 40 mg, 60 mg, 80 mg, and 120 mg tablets

WARNINGS AND PRECAUTIONS**Serious Warnings and Precautions**

Various medicines of the group to which LATUDA belongs have been associated with an increased rate of death when used in elderly patients with dementia. LATUDA is not approved for use in elderly patients with dementia.

BEFORE you use LATUDA, talk to your doctor or pharmacist if you:

- are taking any other medicines (prescriptions or over the counter medicines)
- are pregnant, think you are pregnant, or plan to become pregnant
- are breastfeeding or plan to breastfeed
- are an elderly patient suffering from dementia (loss of memory and other mental abilities)
- exercise vigorously or work in hot or sunny places
- have high blood sugar or a history of diabetes
- have a history of kidney or liver problems
- have involuntary, irregular muscle movements, especially in the face or tongue
- have high blood pressure or rapid heartbeats and a drop in pressure when getting up
- have low blood pressure
- suffer from heart disease or have a family history of heart disease, stroke, or "mini" stroke
- have had problems with the way your heart beats (arrhythmias) or are taking medications that affect how your heart beats
- have heart problems including "QT prolongation"
- are at risk for developing blood clots. Risks include:
 - a family history of blood clots
 - being over age over 65
 - smoking
 - being over weight

- a recent major surgery (such as hip or knee replacement)
- not being able to move due to air travel or other reason
- take birth control ("The Pill")
- have or have had breast cancer
- have pituitary tumours
- drink alcohol or use street drugs
- have ever had fainting, blackouts, or seizures
- work with hazardous machinery or drive a motorized vehicle
- have or have had low levels of white blood cells

Other warnings you should know about:

Effects in newborns: In some cases, babies born to a mother taking LATUDA while they are pregnant can have serious health problems. Sometimes, the symptoms may get better on their own. Be prepared to get immediate medical help for your newborn if they:

- have trouble breathing
- are overly sleepy
- have muscle stiffness or floppy muscles (like a rag doll)
- have trouble feeding.

Driving and using machines: LATUDA may make you feel drowsy. Do not drive a car or operate machinery until you know how LATUDA affects you.

Low Blood Pressure: When taking LATUDA, some people may faint, feel lightheaded or dizzy, especially when getting up from a lying or sitting position. This is more likely to happen if you are elderly and also at the start of treatment or when the dose is increased. This will usually go away on its own but if it does not, tell your doctor.

Dehydration and overheating: When taking LATUDA, it is important not to become too hot or dehydrated. Do not exercise too much and try to avoid extreme heat.

Falls: Feeling sleepy, a fall in blood pressure when you stand up from sitting or lying down, vision or speech problems have been reported with the use of antipsychotic drugs. This can lead to falls that may cause fractures or other fall-related injuries. Certain medications, diseases or conditions can make this worse.

INTERACTIONS WITH THIS MEDICATION

Tell all doctors, dentists, and pharmacists who are treating you that you are taking LATUDA.

As well, be sure to tell them about any other medications you take, including any drugs, vitamins, minerals, natural supplements or alternative medicines.

Inform your doctor if you start or stop taking any of the following medications as they may interact with LATUDA:

- Drugs used to treat fungal infections such as ketoconazole, itraconazole, fluconazole
- Drugs used to treat HIV infection and AIDS such as ritonavir
- Anti-seizure drugs such as phenobarbital or phenytoin
- Drugs used to lower blood pressure such as diltiazem or verapamil

- Certain antibiotics used to treat infections such as rifampin or erythromycin
- Drugs used to treat problems with your heart beat (antiarrhythmics)
- Diuretics (water pills)

The effects of alcohol could be made worse while taking LATUDA. It is recommended that you **do not** drink alcohol while taking LATUDA.

You should avoid consuming grapefruit, grapefruit juice, or products containing grapefruit extract while receiving LATUDA.

PROPER USE OF THIS MEDICATION

Usual Adult and Adolescent (15-17 years old) Dose:

Schizophrenia:

Usual starting dose: 40 mg once a day. The highest recommended dose for adolescents is 80 mg.

Usual Adult and Adolescent (13-17 years old) Dose:

Depression Associated with Bipolar Disorder:

Usual starting dose: 20 mg once a day alone or in combination with lithium or valproate.

Take LATUDA exactly the way your doctor has prescribed it, every day and at the same time. You should check with your doctor or pharmacist if you are not sure. Your doctor has decided on the best dose for you based on your individual situation. Your doctor may increase or decrease your dose depending on your response.

Take LATUDA with food (at least 350 calories) and swallow whole with water.

If you have moderate liver problems, your daily dose of LATUDA should not be more than 80 mg. If you have severe liver problems, your daily dose of LATUDA should not be more than 40 mg.

If you have moderate or severe kidney problems, your daily dose of LATUDA should not be more than 80 mg.

LATUDA is not for use in children under 15 years of age with symptoms of schizophrenia. LATUDA is not for use in children under 13 years of age being treated for the symptoms of depression associated with bipolar disorder.

Missed Dose:

If you miss a dose by a few hours, take it as soon as possible. If you are close to your next dose, just skip the missed dose and take your next dose at your regular time. **DO NOT TAKE 2 DOSES OF LATUDA AT THE SAME TIME TO MAKE UP FOR A MISSED DOSE.**

Overdose:

If you have taken more LATUDA tablets than your doctor has recommended (or if someone else has taken some of your LATUDA tablets), contact your regional Poison Control Centre and talk to your doctor right away or go to your nearest hospital emergency department. Take the medication package with you.

SIDE EFFECTS AND WHAT TO DO ABOUT THEM

Like other medicines, LATUDA can cause some side effects. These side effects are likely to be minor and temporary. However, some may be serious and need medical attention.

The most common side effects of LATUDA in adult patients with schizophrenia are:

- drowsiness/sleepiness
- feeling of restlessness (akathisia)
- abnormal movements, tremor, muscle stiffness, slowing of movement
- nausea

The most common side effects of LATUDA in adolescent patients (15-17 years) with schizophrenia are:

- drowsiness/sleepiness
- nausea
- feeling of restlessness (akathisia)
- abnormal movements, tremor, muscle stiffness, slowing of movement
- vomiting

The most common side effects of LATUDA in adult patients with depression associated with bipolar disorder are:

- feeling of restlessness (akathisia)
- abnormal movements, tremor, muscle stiffness, slowing of movement.

The most common side effects of LATUDA in adolescent patients (13-17 years) with depression associated with bipolar disorder are:

- nausea
- weight gain
- inability to sleep (insomnia)
- drowsiness/sleepiness

Other side effects of LATUDA include:

- Symptoms of an allergic reaction including rash, itching, flushing, and/or inflammation of the mouth and/or skin (see also **SERIOUS SIDE EFFECTS, HOW OFTEN THEY HAPPEN AND WHAT TO DO ABOUT THEM**).
- Increase in the amount of sugar (glucose) in the blood (hyperglycemia). Symptoms of high blood sugar can include feeling very thirsty and/or hungry, needing to urinate more than usual, feeling weak or tired, feeling sick to your stomach, feeling confused, fruity smelling breath.
- Decreased blood pressure. Symptoms of decreased blood pressure can include lightheadedness or fainting when rising too quickly from a sitting or lying position.

The following may also occur with LATUDA, and may be seen in routine blood testing:

- decrease in the amount of white blood cells
- increase in the amount of hormone prolactin in the blood which:
 - in women, may lead to swelling of breasts and unexpected production of breast milk and changes in the regularity of monthly periods; and
 - in men, may lead to diminished sexual function and breast enlargement

If you have high levels of prolactin (measured with a blood test) and a condition called hypogonadism you may be at an increased risk of breaking a bone due to osteoporosis. This occurs in both men and women.

Your doctor should check your body weight before starting LATUDA and continue to monitor it for as long as you are being treated.

Your doctor should take blood tests before starting LATUDA. They will monitor blood sugar and the number of infection fighting white blood cells. Your doctor should continue to monitor your blood for as long as you are being treated.

You should tell your doctor if you notice any symptoms that worry you, even if you think the problems are not connected with the medicine or are not listed here.

SERIOUS SIDE EFFECTS, HOW OFTEN THEY HAPPEN AND WHAT TO DO ABOUT THEM

Symptom / effect		Talk with your doctor or pharmacist		Stop taking drug and seek immediate medical emergency help
		Only if severe	In all cases	
Common	New or worsening constipation		√	
Uncommon	Involuntary movements mainly of your face or tongue (tardive dyskinesia)		√	
	Sudden weakness or numbness of the face, arms, or legs and slurred speech or vision problems, even if for a short period of time			√
	Feeling faint, or dizzy, or lose consciousness, or feel a change in the way your heart beats (palpitations)		√	
	Difficulty swallowing		√	

SERIOUS SIDE EFFECTS, HOW OFTEN THEY HAPPEN AND WHAT TO DO ABOUT THEM

Symptom / effect		Talk with your doctor or pharmacist		Stop taking drug and seek immediate medical emergency help
		Only if severe	In all cases	
Rare	Pronounced muscle stiffness or inflexibility with high fever, rapid or irregular heartbeat, sweating, state of confusion, or reduced consciousness (Neuroleptic Malignant Syndrome)			√
	Seizure (loss of consciousness with uncontrollable shaking)			√
	Symptoms of a severe allergic reaction such as swelling of the mouth, face, lips, or tongue, and may include difficulty breathing			√
	Blood clots: swelling, pain and redness in an arm or leg that can be warm to touch. You may develop sudden chest pain, difficulty breathing, and heart palpitations.		√	
	Very dark (“tea coloured”) urine, muscle tenderness, and/or aching (rhabdomyolysis)			√
	Long-lasting (greater than 4 hours in duration) and painful erection of the penis			√

SERIOUS SIDE EFFECTS, HOW OFTEN THEY HAPPEN AND WHAT TO DO ABOUT THEM

Symptom / effect		Talk with your doctor or pharmacist		Stop taking drug and seek immediate medical emergency help
		Only if severe	In all cases	
Unknown	Drug Reaction with Eosinophilia and Systemic Symptoms (DRESS) (serious skin reaction that may affect more than one or more organs): fever, severe rash, swollen lymph glands, flu-like feeling, yellow skin or eyes, shortness of breath, dry cough, chest pain or discomfort, feel thirsty, urinate less often, less urine			√

This is not a complete list of side effects. For any unexpected effects while taking LATUDA, contact your doctor or pharmacist.

HOW TO STORE IT

Store at room temperature (15 – 30°C).

The expiry date of this medicine is printed on the package label. Do not use the medicine after this date. Keep out of the reach and sight of children.

REPORTING SUSPECTED SIDE EFFECTS

You can report any suspected adverse reactions associated with the use of health products to the Canada Vigilance Program by one of the following 3 ways:

- Report online at <https://www.canada.ca/en/health-canada/services/drugs-health-products/medeffect-canada/adverse-reaction-reporting.html>
- Call toll-free at 1-866-234-2345
- Complete a Canada Vigilance Reporting Form and:
 - Fax toll-free to 1-866-678-6789, or
 - Mail to: **Canada Vigilance Program
Health Canada
Postal Locator 1908C
Ottawa, Ontario
K1A 0K9**

Postage paid labels, Canada Vigilance Reporting Form and the adverse reaction reporting guidelines are available on the MedEffect™ Canada Web site at <https://www.canada.ca/en/health-canada/services/drugs-health-products/medeffect-canada/adverse-reaction-reporting.html>.

NOTE: Should you require information related to the management of side effects, contact your health professional. The Canada Vigilance Program does not provide medical advice.

MORE INFORMATION

This document plus the full product monograph, prepared for health professionals can be found at: <http://www.sunovion.ca> or by contacting the sponsor, Sunovion Pharmaceuticals Canada Inc. at: 1-866-260-6291.

This leaflet was prepared by Sunovion Pharmaceuticals Canada Inc.

Last revised: March 18, 2020

HIGHLIGHTS OF PRESCRIBING INFORMATION

These highlights do not include all the information needed to use LATUDA safely and effectively. See full prescribing information for LATUDA.

LATUDA (lurasidone hydrochloride) tablets, for oral use
Initial U.S. Approval: 2010

WARNING: INCREASED MORTALITY IN ELDERLY PATIENTS WITH DEMENTIA-RELATED PSYCHOSIS; and SUICIDAL THOUGHTS AND BEHAVIORS

See full prescribing information for complete boxed warning.

- Elderly patients with dementia-related psychosis treated with antipsychotic drugs are at an increased risk of death. LATUDA is not approved for the treatment of patients with dementia-related psychosis (5.1).
- Antidepressants increased the risk of suicidal thoughts and behavior in pediatric and young adult patients. Closely monitor for clinical worsening and emergence of suicidal thoughts and behaviors. (5.2).

RECENT MAJOR CHANGES

Warnings and Precautions, Metabolic Changes, Hyperprolactinemia (5.6, 5.7)
12/2019

INDICATIONS AND USAGE

LATUDA is an atypical antipsychotic indicated for the treatment of:

- Schizophrenia in adults and adolescents (13 to 17 years) (1, 14.1)
- Depressive episode associated with Bipolar I Disorder (bipolar depression) in adults and pediatric patients (10 to 17 years) as monotherapy (1, 14.2)
- Depressive episode associated with Bipolar I Disorder (bipolar depression) in adults as adjunctive therapy with lithium or valproate (1, 14.2)

DOSAGE AND ADMINISTRATION

LATUDA should be taken with food (at least 350 calories). Administration with food substantially increases the absorption of LATUDA (2.3, 12.3).

Indication	Starting Dose	Recommended Dose
Schizophrenia – adults (2.1)	40 mg per day	40 mg to 160 mg per day
Schizophrenia – adolescents (13 to 17 years) (2.1)	40 mg per day	40 mg to 80 mg per day
Bipolar Depression - adults (2.2)	20 mg per day	20 mg to 120 mg per day
Bipolar Depression – pediatric patients (10 to 17 years) (2.2)	20 mg per day	20 mg to 80 mg per day

- **Moderate and Severe Renal Impairment:** Recommended starting dose is 20 mg per day, and the maximum recommended dose is 80 mg per day (2.4, 8.6).
- **Moderate and Severe Hepatic Impairment:** Recommended starting dose is 20 mg per day. The maximum recommended dose is 80 mg per day in moderate hepatic impairment and 40 mg per day in severe hepatic impairment (2.5, 8.7).
- **Concomitant Use of a Moderate CYP3A4 inhibitor (e.g., diltiazem):**

- LATUDA dose should be reduced to half of the original dose level. Recommended starting dose is 20 mg per day. Maximum recommended dose is 80 mg per day (2.6, 7.1).
- **Concomitant Use of a Moderate CYP3A4 Inducer:**
It may be necessary to increase the dose of LATUDA (2.6, 7.1).

DOSAGE FORMS AND STRENGTHS

Tablets: 20 mg, 40 mg, 60 mg, 80 mg and 120 mg (3)

CONTRAINDICATIONS

- Known hypersensitivity to LATUDA or any components in the formulation (4).
- Concomitant use with a strong CYP3A4 inhibitor (e.g., ketoconazole) (2.6, 4, 7.1).
- Concomitant use with a strong CYP3A4 inducer (e.g., rifampin) (2.6, 4, 7.1).

WARNINGS AND PRECAUTIONS

- **Cerebrovascular Adverse Reactions in Elderly Patients with Dementia-Related Psychosis:** Increased incidence of cerebrovascular adverse events (e.g., stroke, transient ischemic attack) (5.3).
- **Neuroleptic Malignant Syndrome:** Manage with immediate discontinuation and close monitoring (5.4).
- **Tardive Dyskinesia:** Discontinue if clinically appropriate (5.5).
- **Metabolic Changes:** Monitor for hyperglycemia/diabetes mellitus, dyslipidemia and weight gain (5.6).
- **Hyperprolactinemia:** Prolactin elevations may occur (5.7).
- **Leukopenia, Neutropenia, and Agranulocytosis:** Perform complete blood counts (CBC) in patients with a pre-existing low white blood cell count (WBC) or a history of leukopenia or neutropenia. Consider discontinuing LATUDA if a clinically significant decline in WBC occurs in the absence of other causative factors (5.8).
- **Orthostatic Hypotension and Syncope:** Monitor heart rate and blood pressure and warn patients with known cardiovascular or cerebrovascular disease, and risk of dehydration or syncope (5.9).

ADVERSE REACTIONS

Commonly observed adverse reactions (incidence \geq 5% and at least twice the rate for placebo) were (6.1):

- Adult patients with schizophrenia: somnolence, akathisia, extrapyramidal symptoms, and nausea
- Adolescent patients (13-17 years) with schizophrenia: somnolence, nausea, akathisia, EPS (non-akathisia), rhinitis (80mg only), and vomiting
- Adult patients with bipolar depression: akathisia, extrapyramidal symptoms, and somnolence
- Pediatric patients (10-17 years) with bipolar depression: nausea, weight increase, and insomnia.

To report SUSPECTED ADVERSE REACTIONS, contact Sunovion Pharmaceuticals Inc. at 1-877-737-7226 or FDA at 1-800-FDA-1088 or www.fda.gov/medwatch.

USE IN SPECIFIC POPULATIONS

- **Pregnancy:** May cause extrapyramidal and/or/withdrawal symptoms in neonates with third trimester exposure (8.1).

See 17 for PATIENT COUNSELING INFORMATION and Medication Guide

Revised: 12/2019

FULL PRESCRIBING INFORMATION: CONTENTS*
WARNING: INCREASED MORTALITY IN ELDERLY PATIENTS
WITH DEMENTIA-RELATED PSYCHOSIS; and SUICIDAL
THOUGHTS BEHAVIORS

1 INDICATIONS AND USAGE

2 DOSAGE AND ADMINISTRATION

- 2.1 Schizophrenia
- 2.2 Depressive Episodes Associated with Bipolar I Disorder
- 2.3 Administration Information
- 2.4 Dose Modifications for Renal Impairment
- 2.5 Dose Modifications for Hepatic Impairment
- 2.6 Dose Modifications Due to Drug Interactions of CYP3A4 Inhibitors and CYP3A4 Inducers

3 DOSAGE FORMS AND STRENGTHS

4 CONTRAINDICATIONS

5 WARNINGS AND PRECAUTIONS

- 5.1 Increased Mortality in Elderly Patients with Dementia-Related Psychosis
- 5.2 Suicidal Thoughts and Behaviors in Pediatric and Young Adult Patients
- 5.3 Cerebrovascular Adverse Reactions, Including Stroke in Elderly Patients with Dementia-Related Psychosis
- 5.4 Neuroleptic Malignant Syndrome
- 5.5 Tardive Dyskinesia
- 5.6 Metabolic Changes
- 5.7 Hyperprolactinemia
- 5.8 Leukopenia, Neutropenia and Agranulocytosis
- 5.9 Orthostatic Hypotension and Syncope
- 5.10 Falls
- 5.11 Seizures
- 5.12 Potential for Cognitive and Motor Impairment
- 5.13 Body Temperature Dysregulation
- 5.14 Activation of Mania/Hypomania
- 5.15 Dysphagia
- 5.16 Neurological Adverse Reactions in Patients with Parkinson's Disease or Dementia with Lewy Bodies

6 ADVERSE REACTIONS

- 6.1 Clinical Trials Experience
- 6.2 Postmarketing Experience

7 DRUG INTERACTIONS

- 7.1 Drugs Having Clinically Important Interactions with LATUDA
- 7.2 Drugs Having No Clinically Important Interactions with LATUDA

8 USE IN SPECIFIC POPULATIONS

- 8.1 Pregnancy
- 8.2 Lactation
- 8.4 Pediatric Use
- 8.5 Geriatric Use
- 8.6 Renal Impairment
- 8.7 Hepatic Impairment
- 8.8 Other Specific Populations

9 DRUG ABUSE AND DEPENDENCE

- 9.1 Controlled Substance
- 9.2 Abuse

10 OVERDOSAGE

- 10.1 Human Experience
- 10.2 Management of Overdosage

11 DESCRIPTION

12 CLINICAL PHARMACOLOGY

- 12.1 Mechanism of Action
- 12.2 Pharmacodynamics
- 12.3 Pharmacokinetics

13 NONCLINICAL TOXICOLOGY

- 13.1 Carcinogenesis, Mutagenesis, Impairment of Fertility

14 CLINICAL STUDIES

- 14.1 Schizophrenia
- 14.2 Depressive Episodes Associated with Bipolar I Disorder

16 HOW SUPPLIED/STORAGE AND HANDLING

17 PATIENT COUNSELING INFORMATION

*Sections or subsections omitted from the Full Prescribing Information are not listed.

FULL PRESCRIBING INFORMATION

WARNING: INCREASED MORTALITY IN ELDERLY PATIENTS WITH DEMENTIA-RELATED PSYCHOSIS; and SUICIDAL THOUGHTS AND BEHAVIORS

Increased Mortality in Elderly Patients with Dementia-Related Psychosis

Elderly patients with dementia-related psychosis treated with antipsychotic drugs are at an increased risk of death. LATUDA is not approved for the treatment of patients with dementia-related psychosis [see *Warnings and Precautions (5.1)*].

Suicidal Thoughts and Behaviors

Antidepressants increased the risk of suicidal thoughts and behavior in pediatric and young adults in short-term studies. Closely monitor all antidepressant-treated patients for clinical worsening, and for emergence of suicidal thoughts and behaviors [see *Warnings and Precautions (5.2)*].

1 INDICATIONS AND USAGE

LATUDA is indicated for:

- Treatment of adult and adolescent patients (13 to 17 years) with schizophrenia [see *Clinical Studies (14.1)*].
- Monotherapy treatment of adult and pediatric patients (10 to 17 years) with major depressive episode associated with bipolar I disorder (bipolar depression) [see *Clinical Studies (14.2)*].
- Adjunctive treatment with lithium or valproate in adult patients with major depressive episode associated with bipolar I disorder (bipolar depression) [see *Clinical Studies (14.2)*].

2 DOSAGE AND ADMINISTRATION

2.1 Schizophrenia

Adults

The recommended starting dose of LATUDA is 40 mg once daily. Initial dose titration is not required. LATUDA has been shown to be effective in a dose range of 40 mg per day to 160 mg per day [see *Clinical Studies (14.1)*]. The maximum recommended dose is 160 mg per day.

Adolescents (13 – 17 years)

The recommended starting dose of LATUDA is 40 mg once daily. Initial dose titration is not required. LATUDA has been shown to be effective in a dose range of 40 mg per day to 80 mg per day [see *Clinical Studies (14.1)*]. The maximum recommended dose is 80 mg per day.

2.2 Depressive Episodes Associated with Bipolar I Disorder

Adults

The recommended starting dose of LATUDA is 20 mg given once daily as monotherapy or as adjunctive therapy with lithium or valproate. Initial dose titration is not required. LATUDA has been shown to be effective in a dose range of 20 mg per day to 120 mg per day as monotherapy or as adjunctive therapy with lithium or valproate [see *Clinical Studies (14.2)*]. The maximum recommended dose, as monotherapy or as adjunctive therapy with lithium or valproate, is 120 mg per day. In the monotherapy study, the higher dose range (80 mg to 120 mg per day) did not provide additional efficacy, on average, compared to the lower dose range (20 to 60 mg per day) [see *Clinical Studies (14.2)*].

Pediatric Patients (10 – 17 years)

The recommended starting dose of LATUDA is 20 mg given once daily as monotherapy. Initial dose titration is not required. The dose may be increased after one week based on clinical response. LATUDA has been shown to be effective in a dose range of 20 mg per day to 80 mg per day as monotherapy. At the end of the clinical study, most of the patients (67%) received 20 mg or 40 mg once daily [see *Clinical Studies (14.2)*]. The maximum recommended dose is 80 mg per day.

The efficacy of LATUDA in the treatment of mania associated with bipolar disorder has not been established.

2.3 Administration Information

LATUDA should be taken with food (at least 350 calories). Administration with food substantially increases the absorption of LATUDA. Administration with food increases the AUC approximately 2-fold and increases the C_{max} approximately 3-fold. In the clinical studies, LATUDA was administered with food [see *Clinical Pharmacology (12.3)*].

The effectiveness of LATUDA for longer-term use, that is, for more than 6 weeks, has not been established in controlled studies. Therefore, the physician who elects to use LATUDA for extended periods should periodically re-evaluate the long-term usefulness of the drug for the individual patient [see *Dosage and Administration (2.1 and 2.2)*].

2.4 Dose Modifications for Renal Impairment

Dose adjustment is recommended in moderate (creatinine clearance: 30 to <50 mL/min) and severe renal impairment (creatinine clearance <30 mL/min) patients. The recommended starting dose is 20 mg per day. The dose in these patients should not exceed 80 mg per day [see *Use in Specific Populations (8.6)*].

2.5 Dose Modifications for Hepatic Impairment

Dose adjustment is recommended in moderate (Child-Pugh Score = 7 to 9) and severe hepatic impairment (Child-Pugh Score = 10 to 15) patients. The recommended starting dose is 20 mg per day. The dose in moderate hepatic impairment patients should not exceed 80 mg per day and the dose in severe hepatic impairment patients should not exceed 40 mg per day [see *Use in Specific Populations (8.7)*].

2.6 Dose Modifications Due to Drug Interactions of CYP3A4 Inhibitors and CYP3A4 Inducers

Concomitant Use with CYP3A4 Inhibitors

LATUDA should not be used concomitantly with a strong CYP3A4 inhibitor (e.g., ketoconazole, clarithromycin, ritonavir, voriconazole, mibefradil, etc.) [*see Contraindications (4)*].

If LATUDA is being prescribed and a moderate CYP3A4 inhibitor (e.g. diltiazem, atazanavir, erythromycin, fluconazole, verapamil etc.) is added to the therapy, the LATUDA dose should be reduced to half of the original dose level. Similarly, if a moderate CYP3A4 inhibitor is being prescribed and LATUDA is added to the therapy, the recommended starting dose of LATUDA is 20 mg per day, and the maximum recommended dose of LATUDA is 80 mg per day [*see Contraindications (4), Drug Interactions (7.1)*].

Grapefruit and grapefruit juice should be avoided in patients taking LATUDA, since these may inhibit CYP3A4 and alter LATUDA concentrations [*see Drug Interactions (7.1)*].

Concomitant Use with CYP3A4 Inducers

LATUDA should not be used concomitantly with a strong CYP3A4 inducer (e.g., rifampin, avasimibe, St. John's wort, phenytoin, carbamazepine, etc.) [*see Contraindications (4); Drug Interactions (7.1)*]. If LATUDA is used concomitantly with a moderate CYP3A4 inducer, it may be necessary to increase the LATUDA dose after chronic treatment (7 days or more) with the CYP3A4 inducer.

3 DOSAGE FORMS AND STRENGTHS

LATUDA tablets are available in the following shape and color ([Table 1](#)) with respective one-sided debossing.

Table 1: LATUDA Tablet Presentations

Tablet Strength	Tablet Color/Shape	Tablet Markings
20 mg	white to off-white round	L20
40 mg	white to off-white round	L40
60 mg	white to off-white oblong	L60
80 mg	pale green oval	L80
120 mg	white to off-white oval	L120

4 CONTRAINDICATIONS

- Known hypersensitivity to lurasidone HCl or any components in the formulation. Angioedema has been observed with lurasidone [*see Adverse Reactions (6.1)*].
- Strong CYP3A4 inhibitors (e.g., ketoconazole, clarithromycin, ritonavir, voriconazole, mibefradil, etc.) [*see Drug Interactions (7.1)*].

- Strong CYP3A4 inducers (e.g., rifampin, avasimibe, St. John’s wort, phenytoin, carbamazepine, etc.) [*see Drug Interactions (7.1)*].

5 WARNINGS AND PRECAUTIONS

5.1 Increased Mortality in Elderly Patients with Dementia-Related Psychosis

Elderly patients with dementia-related psychosis treated with antipsychotic drugs are at an increased risk of death. Analyses of 17 placebo-controlled trials (modal duration of 10 weeks), largely in patients taking atypical antipsychotic drugs, revealed a risk of death in drug-treated patients of between 1.6- to 1.7-times the risk of death in placebo-treated patients. Over the course of a typical 10-week controlled trial, the rate of death in drug-treated patients was about 4.5%, compared to a rate of about 2.6% in the placebo group. Although the causes of death were varied, most of the deaths appeared to be either cardiovascular (e.g., heart failure, sudden death) or infectious (e.g., pneumonia) in nature. LATUDA is not approved for the treatment of patients with dementia-related psychosis [*see Boxed Warning, Warnings and Precautions (5.3)*].

5.2 Suicidal Thoughts and Behaviors in Pediatric and Young Adult Patients

In pooled analyses of placebo-controlled trials of antidepressant drugs (SSRIs and other antidepressant classes) that included approximately 77,000 adult patients, and over 4,400 pediatric patients, the incidence of suicidal thoughts and behaviors in pediatric and young adult patients was greater in antidepressant-treated patients than in placebo-treated patients. The drug-placebo differences in the number of cases of suicidal thoughts and behaviors per 1000 patients treated are provided in [Table 2](#).

No suicides occurred in any of the pediatric studies. There were suicides in the adult studies, but the number was not sufficient to reach any conclusion about antidepressant drug effect on suicide.

Table 2: Risk Differences of the Number of Cases of Suicidal Thoughts or Behaviors in the Pooled Placebo-Controlled Trials of Antidepressants in Pediatric and Adult Patients

Age Range	Drug-Placebo Difference in Number of Patients of Suicidal Thoughts or Behaviors per 1000 Patients Treated
	Increases Compared to Placebo
<18	14 additional patients
18-24	5 additional patients
	Decreases Compared to Placebo
25-64	1 fewer patient
≥65	6 fewer patients

It is unknown whether the risk of suicidal thoughts and behaviors in pediatric and young adult patients extends to longer-term use, i.e., beyond four months. However, there is substantial evidence from placebo-controlled maintenance studies in adults with MDD that antidepressants delay the recurrence of depression.

Monitor all antidepressant-treated patients for clinical worsening and emergence of suicidal thoughts and behaviors, especially during the initial few months of drug therapy and at times of dosage changes. Counsel family members or caregivers of patients to monitor for changes in behavior and to alert the healthcare provider. Consider changing the therapeutic regimen, including possibly discontinuing LATUDA, in patients whose depression is persistently worse, or who are experiencing emergent suicidal thoughts or behaviors.

5.3 Cerebrovascular Adverse Reactions, Including Stroke in Elderly Patients with Dementia-Related Psychosis

In placebo-controlled trials with risperidone, aripiprazole, and olanzapine in elderly subjects with dementia, there was a higher incidence of cerebrovascular adverse reactions (cerebrovascular accidents and transient ischemic attacks), including fatalities, compared to placebo-treated subjects. LATUDA is not approved for the treatment of patients with dementia-related psychosis [see *Boxed Warning, Warnings and Precautions (5.1)*].

5.4 Neuroleptic Malignant Syndrome

A potentially fatal symptom complex sometimes referred to as Neuroleptic Malignant Syndrome (NMS) has been reported in association with administration of antipsychotic drugs, including LATUDA. Clinical manifestations of NMS are hyperpyrexia, muscle rigidity, altered mental status, and evidence of autonomic instability. Additional signs may include elevated creatine phosphokinase, myoglobinuria (rhabdomyolysis), and acute renal failure.

If NMS is suspected, immediately discontinue LATUDA and provide intensive symptomatic treatment and monitoring.

5.5 Tardive Dyskinesia

Tardive dyskinesia is a syndrome consisting of potentially irreversible, involuntary, dyskinetic movements that can develop in patients treated with antipsychotic drugs. Although the prevalence of the syndrome appears to be highest among the elderly, especially elderly women, it is impossible to rely upon prevalence estimates to predict, at the inception of antipsychotic treatment, which patients are likely to develop the syndrome. Whether antipsychotic drug products differ in their potential to cause tardive dyskinesia is unknown.

The risk of developing tardive dyskinesia and the likelihood that it will become irreversible are believed to increase as the duration of treatment and the total cumulative dose of antipsychotic drugs administered to the patient increase. However, the syndrome can develop, although much less commonly, after relatively brief treatment periods at low doses or may even arise after discontinuation of treatment.

The syndrome may remit, partially or completely, if antipsychotic treatment is withdrawn. Antipsychotic treatment, itself, however, may suppress (or partially suppress) the signs and symptoms of the syndrome and thereby may possibly mask the underlying process. The effect that symptomatic suppression has upon the long-term course of the syndrome is unknown.

Given these considerations, LATUDA should be prescribed in a manner that is most likely to minimize the occurrence of tardive dyskinesia. Chronic antipsychotic treatment should generally be reserved for patients who suffer from a chronic illness that (1) is known to respond to antipsychotic drugs, and (2) for whom alternative, equally effective, but potentially less harmful treatments are not available or appropriate. In patients who do require chronic treatment, the smallest dose and the shortest duration of treatment producing a satisfactory clinical response should be sought. The need for continued treatment should be reassessed periodically.

If signs and symptoms of tardive dyskinesia appear in a patient on LATUDA, drug discontinuation should be considered. However, some patients may require treatment with LATUDA despite the presence of the syndrome.

5.6 Metabolic Changes

Atypical antipsychotic drugs have been associated with metabolic changes that may increase cardiovascular/cerebrovascular risk. These metabolic changes include hyperglycemia, dyslipidemia, and body weight gain. While all of the drugs in the class have been shown to produce some metabolic changes, each drug has its own specific risk profile.

Hyperglycemia and Diabetes Mellitus

Hyperglycemia, in some cases extreme and associated with ketoacidosis or hyperosmolar coma or death, has been reported in patients treated with atypical antipsychotics. Assessment of the relationship between atypical antipsychotic use and glucose abnormalities is complicated by the possibility of an increased background risk of diabetes mellitus in patients with schizophrenia and the increasing incidence of diabetes mellitus in the general population. Given these confounders, the relationship between atypical antipsychotic use and hyperglycemia-related adverse events is not completely understood. However, epidemiological studies suggest an increased risk of hyperglycemia-related adverse events in patients treated with the atypical antipsychotics.

Patients with an established diagnosis of diabetes mellitus who are started on atypical antipsychotics should be monitored regularly for worsening of glucose control. Patients with risk factors for diabetes mellitus (e.g., obesity, family history of diabetes) who are starting treatment with atypical antipsychotics should undergo fasting blood glucose testing at the beginning of treatment and periodically during treatment. Any patient treated with atypical antipsychotics should be monitored for symptoms of hyperglycemia including polydipsia, polyuria, polyphagia, and weakness. Patients who develop symptoms of hyperglycemia during treatment with atypical antipsychotics should undergo fasting blood glucose testing. In some cases, hyperglycemia has resolved when the atypical antipsychotic was discontinued; however, some patients required continuation of anti-diabetic treatment despite discontinuation of the suspect drug.

Schizophrenia

Adults

Pooled data from short-term, placebo-controlled schizophrenia studies are presented in [Table 3](#).

Table 3: Change in Fasting Glucose in Adult Schizophrenia Studies

	LATUDA					
	Placebo	20 mg/day	40 mg/day	80 mg/day	120 mg/day	160 mg/day
Mean Change from Baseline (mg/dL)						
	n=680	n=71	n=478	n=508	n=283	n=113
Serum Glucose	-0.0	-0.6	+2.6	-0.4	+2.5	+2.5
Proportion of Patients with Shifts to ≥ 126 mg/dL						
Serum Glucose (≥ 126 mg/dL)	8.3% (52/628)	11.7% (7/60)	12.7% (57/449)	6.8% (32/472)	10.0% (26/260)	5.6% (6/108)

In the uncontrolled, longer-term schizophrenia studies (primarily open-label extension studies), LATUDA was associated with a mean change in glucose of +1.8 mg/dL at week 24 (n=355), +0.8 mg/dL at week 36 (n=299) and +2.3 mg/dL at week 52 (n=307).

Adolescents

In studies of adolescents and adults with schizophrenia, changes in fasting glucose were similar. In the short-term, placebo-controlled study of adolescents, fasting serum glucose mean values were -1.3 mg/dL for placebo (n=95), +0.1 mg/dL for 40 mg/day (n=90), and +1.8 mg/dL for 80 mg/day (n=92).

Bipolar Depression

Adults

Monotherapy

Data from the adult short-term, flexible-dose, placebo-controlled monotherapy bipolar depression study are presented in [Table 4](#).

Table 4: Change in Fasting Glucose in the Adult Monotherapy Bipolar Depression Study

	LATUDA		
	Placebo	20 to 60 mg/day	80 to 120 mg/day
Mean Change from Baseline (mg/dL)			
	n=148	n=140	n=143
Serum Glucose	+1.8	-0.8	+1.8
Proportion of Patients with Shifts to ≥ 126 mg/dL			
Serum Glucose (≥ 126 mg/dL)	4.3% (6/141)	2.2% (3/138)	6.4% (9/141)

Patients were randomized to flexibly dosed LATUDA 20 to 60 mg/day, LATUDA 80 to 120 mg/day, or placebo

In the uncontrolled, open-label, longer-term bipolar depression study, patients who received LATUDA as monotherapy in the short-term study and continued in the longer-term study, had a mean change in glucose of +1.2 mg/dL at week 24 (n=129).

Adjunctive Therapy with Lithium or Valproate

Data from the adult short-term, flexible-dosed, placebo-controlled adjunctive therapy bipolar depression studies are presented in [Table 5](#).

Table 5: Change in Fasting Glucose in the Adult Adjunctive Therapy Bipolar Depression Studies

	Placebo	LATUDA 20 to 120 mg/day
Mean Change from Baseline (mg/dL)		
	n=302	n=319
Serum Glucose	-0.9	+1.2
Proportion of Patients with Shifts to ≥ 126 mg/dL		
Serum Glucose (≥ 126 mg/dL)	1.0% (3/290)	1.3% (4/316)

Patients were randomized to flexibly dosed LATUDA 20 to 120 mg/day or placebo as adjunctive therapy with lithium or valproate.

In the uncontrolled, open-label, longer-term bipolar depression study, patients who received LATUDA as adjunctive therapy with either lithium or valproate in the short-term study and continued in the longer-term study, had a mean change in glucose of +1.7 mg/dL at week 24 (n=88).

Pediatric Patients (10 to 17 years)

In studies of pediatric patients 10 to 17 years and adults with bipolar depression, changes in fasting glucose were similar. In the 6-week, placebo-controlled study of pediatric patients with bipolar depression, mean change in fasting glucose was +1.6 mg/dL for LATUDA 20 to 80 mg/day (n=145) and -0.5 mg/dL for placebo (n=145).

Pediatric Patients (6 to 17 years)

In a 104-week, open-label study in pediatric patients with schizophrenia, bipolar depression, or autistic disorder, 7 % of patients with a normal baseline fasting glucose experienced a shift to high at endpoint while taking lurasidone.

Dyslipidemia

Undesirable alterations in lipids have been observed in patients treated with atypical antipsychotics.

Schizophrenia

Adults

Pooled data from short-term, placebo-controlled schizophrenia studies are presented in [Table 6](#).

Table 6: Change in Fasting Lipids in Adult Schizophrenia Studies

	LATUDA					
	Placebo	20 mg/day	40 mg/day	80 mg/day	120 mg/day	160 mg/day
Mean Change from Baseline (mg/dL)						
	n=660	n=71	n=466	n=499	n=268	n=115
Total Cholesterol	-5.8	-12.3	-5.7	-6.2	-3.8	-6.9
Triglycerides	-13.4	-29.1	-5.1	-13.0	-3.1	-10.6
Proportion of Patients with Shifts						
Total Cholesterol (\geq 240 mg/dL)	5.3% (30/571)	13.8% (8/58)	6.2% (25/402)	5.3% (23/434)	3.8% (9/238)	4.0% (4/101)
Triglycerides (\geq 200 mg/dL)	10.1% (53/526)	14.3% (7/49)	10.8% (41/379)	6.3% (25/400)	10.5% (22/209)	7.0% (7/100)

In the uncontrolled, longer-term schizophrenia studies (primarily open-label extension studies), LATUDA was associated with a mean change in total cholesterol and triglycerides of -3.8 (n=356) and -15.1 (n=357) mg/dL at week 24, -3.1 (n=303) and -4.8 (n=303) mg/dL at week 36 and -2.5 (n=307) and -6.9 (n=307) mg/dL at week 52, respectively.

Adolescents

In the adolescent short-term, placebo-controlled study, fasting serum cholesterol mean values were -9.6 mg/dL for placebo (n=95), -4.4 mg/dL for 40 mg/day (n=89), and +1.6 mg/dL for 80 mg/day (n=92), and fasting serum triglyceride mean values were +0.1 mg/dL for placebo (n=95), -0.6 mg/dL for 40 mg/day (n=89), and +8.5 mg/dL for 80 mg/day (n=92).

Bipolar Depression

Adults

Monotherapy

Data from the adult short-term, flexible-dosed, placebo-controlled, monotherapy bipolar depression study are presented in [Table 7](#).

Table 7: Change in Fasting Lipids in the Adult Monotherapy Bipolar Depression Study

	Placebo	LATUDA	
		20 to 60 mg/day	80 to 120 mg/day
Mean Change from Baseline (mg/dL)			
	n=147	n=140	n=144
Total cholesterol	-3.2	+1.2	-4.6
Triglycerides	+6.0	+5.6	+0.4
Proportion of Patients with Shifts			
Total cholesterol (≥ 240 mg/dL)	4.2% (5/118)	4.4% (5/113)	4.4% (5/114)
Triglycerides (≥ 200 mg/dL)	4.8% (6/126)	10.1% (12/119)	9.8% (12/122)

Patients were randomized to flexibly dosed LATUDA 20 to 60 mg/day, LATUDA 80 to 120 mg/day, or placebo

In the uncontrolled, open-label, longer-term bipolar depression study, patients who received LATUDA as monotherapy in the short-term and continued in the longer-term study had a mean change in total cholesterol and triglycerides of -0.5 mg/dL (n=130) and -1.0 mg/dL (n=130) at week 24, respectively.

Adjunctive Therapy with Lithium or Valproate

Data from the adult short-term, flexible-dosed, placebo-controlled, adjunctive therapy bipolar depression studies are presented in [Table 8](#).

Table 8: Change in Fasting Lipids in the Adult Adjunctive Therapy Bipolar Depression Studies

	Placebo	LATUDA
		20 to 120 mg/day
Mean Change from Baseline (mg/dL)		
	n=303	n=321
Total cholesterol	-2.9	-3.1
Triglycerides	-4.6	+4.6
Proportion of Patients with Shifts		
Total cholesterol (≥ 240 mg/dL)	5.7% (15/263)	5.4% (15/276)
Triglycerides (≥ 200 mg/dL)	8.6% (21/243)	10.8% (28/260)

Patients were randomized to flexibly dosed LATUDA 20 to 120 mg/day or placebo as adjunctive therapy with lithium or valproate.

In the uncontrolled, open-label, longer-term bipolar depression study, patients who received LATUDA, as adjunctive therapy with either lithium or valproate in the short-term study and

continued in the longer-term study, had a mean change in total cholesterol and triglycerides of -0.9 (n=88) and +5.3 (n=88) mg/dL at week 24, respectively.

Pediatric Patients (10 to 17 years)

In the 6-week, placebo-controlled bipolar depression study with pediatric patients 10 to 17 years, mean change in fasting cholesterol was -6.3 mg/dL for LATUDA 20 to 80 mg/day (n=144) and -1.4 mg/dL for placebo (n=145), and mean change in fasting triglyceride was -7.6 mg/dL for LATUDA 20 to 80 mg/day (n=144) and +5.9 mg/dL for placebo (n=145).

Pediatric Patients (6 to 17 years)

In a 104-week, open-label study of pediatric patients with schizophrenia, bipolar depression, or autistic disorder, shifts in baseline fasting cholesterol from normal to high at endpoint were reported in 12% (total cholesterol), 3% (LDL cholesterol), and shifts in baseline from normal to low were reported in 27% (HDL cholesterol) of patients taking lurasidone. Of patients with normal baseline fasting triglycerides, 12% experienced shifts to high.

Weight Gain

Weight gain has been observed with atypical antipsychotic use. Clinical monitoring of weight is recommended.

Schizophrenia

Adults

Pooled data from short-term, placebo-controlled schizophrenia studies are presented in [Table 9](#). The mean weight gain was +0.43 kg for LATUDA-treated patients compared to -0.02 kg for placebo-treated patients. Change in weight from baseline for olanzapine was +4.15 kg and for quetiapine extended-release was +2.09 kg in Studies 3 and 5 [*see Clinical Studies (14.1)*], respectively. The proportion of patients with a $\geq 7\%$ increase in body weight (at Endpoint) was 4.8% for LATUDA-treated patients and 3.3% for placebo-treated patients.

Table 9: Mean Change in Weight (kg) from Baseline in Adult Schizophrenia Studies

	LATUDA					
	Placebo (n=696)	20 mg/day (n=71)	40 mg/day (n=484)	80 mg/day (n=526)	120 mg/day (n=291)	160 mg/day (n=114)
All Patients	-0.02	-0.15	+0.22	+0.54	+0.68	+0.60

In the uncontrolled, longer-term schizophrenia studies (primarily open-label extension studies), LATUDA was associated with a mean change in weight of -0.69 kg at week 24 (n=755), -0.59 kg at week 36 (n=443) and -0.73 kg at week 52 (n=377).

Adolescents

Data from the short-term, placebo-controlled adolescent schizophrenia study are presented in [Table 10](#). The mean change in weight gain was +0.5 kg for LATUDA-treated patients compared to +0.2 kg for placebo-treated patients. The proportion of patients with a $\geq 7\%$ increase in body weight (at Endpoint) was 3.3% for LATUDA-treated patients and 4.5% for placebo-treated patients.

Table 10: Mean Change in Weight (kg) from Baseline in the Adolescent Schizophrenia Study

	LATUDA		
	Placebo (n=111)	40 mg/day (n=109)	80 mg/day (n=104)
All Patients	+0.2	+0.3	+0.7

Bipolar Depression

Adults

Monotherapy

Data from the adult short-term, flexible-dosed, placebo-controlled monotherapy bipolar depression study are presented in Table 11. The mean change in weight gain was +0.29 kg for LATUDA-treated patients compared to -0.04 kg for placebo-treated patients. The proportion of patients with a $\geq 7\%$ increase in body weight (at Endpoint) was 2.4% for LATUDA-treated patients and 0.7% for placebo-treated patients.

Table 11: Mean Change in Weight (kg) from Baseline in the Adult Monotherapy Bipolar Depression Study

	LATUDA		
	Placebo (n=151)	20 to 60 mg/day (n=143)	80 to 120 mg/day (n=147)
All Patients	-0.04	+0.56	+0.02

Patients were randomized to flexibly dosed LATUDA 20 to 60 mg/day, LATUDA 80 to 120 mg/day, or placebo

In the uncontrolled, open-label, longer-term bipolar depression study, patients who received LATUDA as monotherapy in the short-term and continued in the longer-term study had a mean change in weight of -0.02 kg at week 24 (n=130).

Adjunctive Therapy with Lithium or Valproate

Data from the adult short-term, flexible-dosed, placebo-controlled adjunctive therapy bipolar depression studies are presented in Table 12. The mean change in weight gain was +0.11 kg for LATUDA-treated patients compared to +0.16 kg for placebo-treated patients. The proportion of patients with a $\geq 7\%$ increase in body weight (at Endpoint) was 3.1% for LATUDA-treated patients and 0.3% for placebo-treated patients.

Table 12: Mean Change in Weight (kg) from Baseline in the Adult Adjunctive Therapy Bipolar Depression Studies

	LATUDA	
	Placebo (n=307)	20 to 120 mg/day (n=327)
All Patients	+0.16	+0.11

Patients were randomized to flexibly dosed LATUDA 20 to 120 mg/day or placebo as adjunctive therapy with lithium or valproate.

In the uncontrolled, open-label, longer-term bipolar depression study, patients who were treated with LATUDA, as adjunctive therapy with either lithium or valproate in the short-term and continued in the longer-term study, had a mean change in weight of +1.28 kg at week 24 (n=86).

Pediatric Patients (10 to 17 years)

Data from the 6-week, placebo-controlled bipolar depression study in patients 10 to 17 years are presented in Table 13. The mean change in weight gain was +0.7 kg for LATUDA-treated patients compared to +0.5 kg for placebo-treated patients. The proportion of patients with a $\geq 7\%$ increase in body weight (at Endpoint) was 4.0% for LATUDA-treated patients and 5.3% for placebo-treated patients.

Table 13: Mean Change in Weight (kg) from Baseline in the Bipolar Depression Study in Pediatric Patients (10 to 17 years)

	Placebo (n=170)	LATUDA 20 to 80 mg/day (n=175)
All Patients	+0.5	+0.7

Pediatric Patients (6 to 17 years)

In a long-term, open-label study that enrolled pediatric patients with schizophrenia, bipolar depression, or autistic disorder from three short-term, placebo-controlled trials, 54% (378/701) received lurasidone for 104 weeks. The mean increase in weight from open-label baseline to Week 104 was 5.85 kg. To adjust for normal growth, z-scores were derived (measured in standard deviations [SD]), which normalize for the natural growth of children and adolescents by comparisons to age- and sex-matched population standards. A z-score change < 0.5 SD is considered not clinically significant. In this trial, the mean change in z-score from open-label baseline to Week 104 was -0.06 SD for body weight and -0.13 SD for body mass index (BMI), indicating minimal deviation from the normal curve for weight gain.

5.7 Hyperprolactinemia

As with other drugs that antagonize dopamine D₂ receptors, LATUDA elevates prolactin levels.

Hyperprolactinemia may suppress hypothalamic GnRH, resulting in reduced pituitary gonadotrophin secretion. This, in turn, may inhibit reproductive function by impairing gonadal steroidogenesis in both female and male patients. Galactorrhea, amenorrhea, gynecomastia, and impotence have been reported with prolactin-elevating compounds. Long-standing hyperprolactinemia, when associated with hypogonadism, may lead to decreased bone density in both female and male patients [see *Adverse Reactions (6)*].

Tissue culture experiments indicate that approximately one-third of human breast cancers are prolactin-dependent *in vitro*, a factor of potential importance if the prescription of these drugs is considered in a patient with previously detected breast cancer. As is common with compounds which increase prolactin release, an increase in mammary gland neoplasia was observed in a carcinogenicity study conducted with lurasidone in rats and mice [see *Nonclinical Toxicology (13)*]. Neither clinical studies nor epidemiologic studies conducted to date have shown an

association between chronic administration of this class of drugs and tumorigenesis in humans, but the available evidence is too limited to be conclusive.

Schizophrenia

Adults

In short-term, placebo-controlled schizophrenia studies, the median change from baseline to endpoint in prolactin levels for LATUDA-treated patients was +0.4 ng/mL and was -1.9 ng/mL in the placebo-treated patients. The median change from baseline to endpoint for males was +0.5 ng/mL and for females was -0.2 ng/mL. Median changes for prolactin by dose are shown in [Table 14](#).

Table 14: Median Change in Prolactin (ng/mL) from Baseline in Adult Schizophrenia Studies

	LATUDA					
	Placebo	20 mg/day	40 mg/day	80 mg/day	120 mg/day	160 mg/day
All Patients	-1.9 (n=672)	-1.1 (n=70)	-1.4 (n=476)	-0.2 (n=495)	+3.3 (n=284)	+3.3 (n=115)
Females	-5.1 (n=200)	-0.7 (n=19)	-4.0 (n=149)	-0.2 (n=150)	+6.7 (n=70)	+7.1 (n=36)
Males	-1.3 (n=472)	-1.2 (n=51)	-0.7 (n=327)	-0.2 (n=345)	+3.1 (n=214)	+2.4 (n=79)

The proportion of patients with prolactin elevations $\geq 5\times$ upper limit of normal (ULN) was 2.8% for LATUDA-treated patients and = 1.0% for placebo-treated patients. The proportion of female patients with prolactin elevations $\geq 5\times$ ULN was 5.7% for LATUDA-treated patients and = 2.0% for placebo-treated female patients. The proportion of male patients with prolactin elevations $\geq 5\times$ ULN was 1.6% and 0.6% for placebo-treated male patients.

In the uncontrolled longer-term schizophrenia studies (primarily open-label extension studies), LATUDA was associated with a median change in prolactin of -0.9 ng/mL at week 24 (n=357), -5.3ng/mL at week 36 (n=190) and -2.2 ng/mL at week 52 (n=307).

Adolescents

In the short-term, placebo-controlled adolescent schizophrenia study, the median change from baseline to endpoint in prolactin levels for LATUDA-treated patients was +1.1 ng/mL and was +0.1 ng/mL for placebo-treated patients. For LATUDA-treated patients, the median change from baseline to endpoint for males was +1.0 ng/mL and for females was +2.6 ng/mL. Median changes for prolactin by dose are shown in [Table 15](#).

Table 15: Median Change in Prolactin (ng/mL) from Baseline in the Adolescent Schizophrenia Study

	Placebo	LATUDA 40 mg/day	LATUDA 80 mg/day
All Patients	+0.10 (n=103)	+0.75 (n=102)	+1.20 (n=99)
Females	+0.70 (n=39)	+0.60 (n=42)	+4.40 (n=33)
Males	0.00 (n=64)	+0.75 (n=60)	+1.00 (n=66)

The proportion of patients with prolactin elevations $\geq 5x$ ULN was 0.5% for LATUDA-treated patients and 1.0% for placebo-treated patients. The proportion of female patients with prolactin elevations $\geq 5x$ ULN was 1.3% for LATUDA-treated patients and 0% for placebo-treated female patients. The proportion of male patients with prolactin elevations $\geq 5x$ ULN was 0% for LATUDA treated patients and 1.6% for placebo-treated male patients.

Bipolar Depression

Adults

Monotherapy

The median change from baseline to endpoint in prolactin levels, in the adult short-term, flexible-dosed, placebo-controlled monotherapy bipolar depression study, was +1.7 ng/mL and +3.5 ng/mL with LATUDA 20 to 60 mg/day and 80 to 120 mg/day, respectively compared to +0.3 ng/mL with placebo-treated patients. The median change from baseline to endpoint for males was +1.5 ng/mL and for females was +3.1 ng/mL. Median changes for prolactin by dose range are shown in [Table 16](#).

Table 16: Median Change in Prolactin (ng/mL) from Baseline in the Adult Monotherapy Bipolar Depression Study

	Placebo	LATUDA	
		20 to 60 mg/day	80 to 120 mg/day
All Patients	+0.3 (n=147)	+1.7 (n=140)	+3.5 (n=144)
Females	0.0 (n=82)	+1.8 (n=78)	+5.3 (n=88)
Males	+0.4 (n=65)	+1.2 (n=62)	+1.9 (n=56)

Patients were randomized to flexibly dosed LATUDA 20 to 60 mg/day, LATUDA 80 to 120 mg/day, or placebo

The proportion of patients with prolactin elevations $\geq 5x$ upper limit of normal (ULN) was 0.4% for LATUDA-treated patients and 0.0% for placebo-treated patients. The proportion of female

patients with prolactin elevations $\geq 5x$ ULN was 0.6% for LATUDA-treated patients and 0% for placebo-treated female patients. The proportion of male patients with prolactin elevations $\geq 5x$ ULN was 0% and 0% for placebo-treated male patients.

In the uncontrolled, open-label, longer-term bipolar depression study, patients who were treated with LATUDA as monotherapy in the short-term and continued in the longer-term study, had a median change in prolactin of -1.15 ng/mL at week 24 (n=130).

Adjunctive Therapy with Lithium or Valproate

The median change from baseline to endpoint in prolactin levels, in the adult short-term, flexible-dosed, placebo-controlled adjunctive therapy bipolar depression studies was +2.8 ng/mL with LATUDA 20 to 120 mg/day compared to 0.0 ng/mL with placebo-treated patients. The median change from baseline to endpoint for males was +2.4 ng/mL and for females was +3.2 ng/mL. Median changes for prolactin across the dose range are shown in [Table 17](#).

Table 17: Median Change in Prolactin (ng/mL) from Baseline in the Adult Adjunctive Therapy Bipolar Depression Studies

	Placebo	LATUDA 20 to 120 mg/day
All Patients	0.0 (n=301)	+2.8 (n=321)
Females	+0.4 (n=156)	+3.2 (n=162)
Males	-0.1 (n=145)	+2.4 (n=159)

Patients were randomized to flexibly dosed LATUDA 20 to 120 mg/day or placebo as adjunctive therapy with lithium or valproate.

The proportion of patients with prolactin elevations $\geq 5x$ upper limit of normal (ULN) was 0.0% for LATUDA-treated patients and 0.0% for placebo-treated patients. The proportion of female patients with prolactin elevations $\geq 5x$ ULN was 0% for LATUDA-treated patients and 0% for placebo-treated female patients. The proportion of male patients with prolactin elevations $\geq 5x$ ULN was 0% and 0% for placebo-treated male patients.

In the uncontrolled, open-label, longer-term bipolar depression study, patients who were treated with LATUDA, as adjunctive therapy with either lithium or valproate, in the short-term and continued in the longer-term study, had a median change in prolactin of -2.9 ng/mL at week 24 (n=88).

Pediatric Patients (10 to 17 years)

In the 6-week, placebo-controlled bipolar depression study with pediatric patients 10 to 17 years, the median change from baseline to endpoint in prolactin levels for LATUDA-treated patients was +1.10 ng/mL and was +0.50 ng/mL for placebo-treated patients. For LATUDA-treated patients, the median change from baseline to endpoint for males was +0.85 ng/mL and for females was +2.50 ng/mL. Median changes for prolactin are shown in [Table 18](#).

Table 18: Median Change in Prolactin (ng/mL) from Baseline in the Bipolar Depression Study in Pediatric Patients (10 to 17 years)

	Placebo	LATUDA 20 to 80 mg/day
All Patients	+0.50 (n=157)	+1.10 (n=165)
Females	+0.55 (n=78)	+2.50 (n=83)
Males	+0.50 (n=79)	+0.85 (n=82)

The proportion of patients with prolactin elevations $\geq 5x$ ULN was 0% for LATUDA-treated patients and 0.6% for placebo-treated patients. The proportion of female patients with prolactin elevations $\geq 5x$ ULN was 0% for LATUDA-treated patients and 1.3% for placebo-treated female patients. No male patients in the placebo or LATUDA treatment groups had prolactin elevations $\geq 5x$ ULN.

Pediatric Patients (6 to 17 years)

In a 104-week, open-label study of pediatric patients with schizophrenia, bipolar depression, or autistic disorder, the median changes from baseline to endpoint in serum prolactin levels were -0.20 ng/mL (all patients), -0.30 ng/mL (females), and -0.05 ng/mL (males). The proportions of patients with a markedly high prolactin level (≥ 5 times the upper limit of normal) at any time during open-label treatment were 2% (all patients), 3% (females), and 1% (males).

Adverse events among females in this trial that are potentially prolactin-related include galactorrhea (0.6%). Among male patients in this study, decreased libido was reported in one patient (0.2%) and there were no reports of impotence, gynecomastia, or galactorrhea.

5.8 Leukopenia, Neutropenia and Agranulocytosis

Leukopenia/neutropenia has been reported during treatment with antipsychotic agents. Agranulocytosis (including fatal cases) has been reported with other agents in the class.

Possible risk factors for leukopenia/neutropenia include pre-existing low white blood cell count (WBC) and history of drug-induced leukopenia/neutropenia. Patients with a pre-existing low WBC or a history of drug-induced leukopenia/neutropenia should have their complete blood count (CBC) monitored frequently during the first few months of therapy and LATUDA should be discontinued at the first sign of decline in WBC, in the absence of other causative factors.

Patients with neutropenia should be carefully monitored for fever or other symptoms or signs of infection and treated promptly if such symptoms or signs occur. Patients with severe neutropenia (absolute neutrophil count $< 1000/mm^3$) should discontinue LATUDA and have their WBC followed until recovery.

5.9 Orthostatic Hypotension and Syncope

LATUDA may cause orthostatic hypotension and syncope, perhaps due to its α 1-adrenergic receptor antagonism. Associated adverse reactions can include dizziness, lightheadedness, tachycardia, and bradycardia. Generally, these risks are greatest at the beginning of treatment and during dose escalation. Patients at increased risk of these adverse reactions or at increased risk of developing complications from hypotension include those with dehydration, hypovolemia, treatment with antihypertensive medication, history of cardiovascular disease (e.g., heart failure, myocardial infarction, ischemia, or conduction abnormalities), history of cerebrovascular disease, as well as patients who are antipsychotic-naïve. In such patients, consider using a lower starting dose and slower titration, and monitor orthostatic vital signs.

Orthostatic hypotension, as assessed by vital sign measurement, was defined by the following vital sign changes: ≥ 20 mm Hg decrease in systolic blood pressure and ≥ 10 bpm increase in pulse from sitting to standing or supine to standing position.

Schizophrenia

Adults

The incidence of orthostatic hypotension and syncope reported as adverse events from short-term, placebo-controlled schizophrenia studies was (LATUDA incidence, placebo incidence): orthostatic hypotension [0.3% (5/1508), 0.1% (1/708)] and syncope [0.1% (2/1508), 0% (0/708)].

In short-term schizophrenia clinical studies, orthostatic hypotension, as assessed by vital signs, occurred with a frequency of 0.8% with LATUDA 40 mg, 2.1% with LATUDA 80 mg, 1.7% with LATUDA 120 mg and 0.8% with LATUDA 160 mg compared to 0.7% with placebo.

Adolescents

The incidence of orthostatic hypotension reported as adverse events from the short-term, placebo-controlled adolescent schizophrenia study was 0.5% (1/214) in LATUDA-treated patients and 0% (0/112) in placebo-treated patients. No syncope event was reported.

Orthostatic hypotension, as assessed by vital signs, occurred with a frequency of 0% with LATUDA 40 mg and 2.9% with LATUDA 80 mg, compared to 1.8% with placebo.

Bipolar Depression

Adults

Monotherapy

In the adult short-term, flexible-dose, placebo-controlled monotherapy bipolar depression study, there were no reported adverse events of orthostatic hypotension and syncope.

Orthostatic hypotension, as assessed by vital signs, occurred with a frequency of 0.6% with LATUDA 20 to 60 mg and 0.6% with LATUDA 80 to 120 mg compared to 0% with placebo.

Adjunctive Therapy with Lithium or Valproate

In the adult short-term, flexible-dose, placebo-controlled adjunctive therapy bipolar depression therapy studies, there were no reported adverse events of orthostatic hypotension and syncope. Orthostatic hypotension, as assessed by vital signs, occurred with a frequency of 1.1% with LATUDA 20 to 120 mg compared to 0.9% with placebo.

Pediatric Patients (10 to 17 years)

In the 6-week, placebo-controlled bipolar depression study in pediatric patients 10 to 17 years, there were no reported adverse events of orthostatic hypotension or syncope.

Orthostatic hypotension, as assessed by vital signs, occurred with a frequency of 1.1% with LATUDA 20 to 80 mg/day, compared to 0.6% with placebo.

5.10 Falls

LATUDA may cause somnolence, postural hypotension, motor and sensory instability, which may lead to falls and, consequently, fractures or other injuries. For patients with diseases, conditions, or medications that could exacerbate these effects, complete fall risk assessments when initiating antipsychotic treatment and recurrently for patients on long-term antipsychotic therapy.

5.11 Seizures

As with other antipsychotic drugs, LATUDA should be used cautiously in patients with a history of seizures or with conditions that lower the seizure threshold, e.g., Alzheimer's dementia. Conditions that lower the seizure threshold may be more prevalent in patients 65 years or older.

Schizophrenia

In adult short-term, placebo-controlled schizophrenia studies, seizures/convulsions occurred in 0.1% (2/1508) of patients treated with LATUDA compared to 0.1% (1/708) placebo-treated patients.

Bipolar Depression

Monotherapy

In the adult and pediatric 6-week, flexible-dose, placebo-controlled monotherapy bipolar depression studies, no patients experienced seizures/convulsions.

Adjunctive Therapy with Lithium or Valproate

In the adult short-term, flexible-dose, placebo-controlled adjunctive therapy bipolar depression studies, no patient experienced seizures/convulsions.

5.12 Potential for Cognitive and Motor Impairment

LATUDA, like other antipsychotics, has the potential to impair judgment, thinking or motor skills. Caution patients about operating hazardous machinery, including motor vehicles, until they are reasonably certain that therapy with LATUDA does not affect them adversely.

In clinical studies with LATUDA, somnolence included: hypersomnia, hypersomnolence, sedation and somnolence.

Schizophrenia

Adults

In short-term, placebo-controlled schizophrenia studies, somnolence was reported by 17.0% (256/1508) of patients treated with LATUDA (15.5% LATUDA 20 mg, 15.6% LATUDA 40 mg, 15.2% LATUDA 80 mg, 26.5% LATUDA 120 mg and 8.3% LATUDA 160 mg/day) compared to 7.1% (50/708) of placebo patients.

Adolescents

In the short-term, placebo-controlled adolescent schizophrenia study, somnolence was reported by 14.5% (31/214) of patients treated with LATUDA (15.5% LATUDA 40 mg and 13.5% LATUDA 80 mg,/day) compared to 7.1% (8/112) of placebo patients.

Bipolar Depression

Adults

Monotherapy

In the adult short-term, flexible-dosed, placebo-controlled monotherapy bipolar depression study, somnolence was reported by 7.3% (12/164) and 13.8% (23/167) with LATUDA 20 to 60 mg and 80 to 120 mg, respectively compared to 6.5% (11/168) of placebo patients.

Adjunctive Therapy with Lithium or Valproate

In the adult short-term, flexible-dosed, placebo-controlled adjunctive therapy bipolar depression studies, somnolence was reported by 11.4% (41/360) of patients treated with LATUDA 20-120 mg compared to 5.1% (17/334) of placebo patients.

Pediatric Patients (10 to 17 years)

In the 6-week, placebo-controlled bipolar depression study in pediatric patients 10 to 17 years, somnolence was reported by 11.4% (20/175) of patients treated with LATUDA 20 to 80 mg/day compared to 5.8% (10/172) of placebo treated patients.

5.13 Body Temperature Dysregulation

Disruption of the body's ability to reduce core body temperature has been attributed to antipsychotic agents. Appropriate care is advised when prescribing LATUDA for patients who will be experiencing conditions that may contribute to an elevation in core body temperature, e.g., exercising strenuously, exposure to extreme heat, receiving concomitant medication with anticholinergic activity, or being subject to dehydration.

5.14 Activation of Mania/Hypomania

Antidepressant treatment can increase the risk of developing a manic or hypomanic episode, particularly in patients with bipolar disorder. Monitor patients for the emergence of such episodes.

In the adult bipolar depression monotherapy and adjunctive therapy (with lithium or valproate) studies, less than 1% of subjects in the LATUDA and placebo groups developed manic or hypomanic episodes.

5.15 Dysphagia

Esophageal dysmotility and aspiration have been associated with antipsychotic drug use. Aspiration pneumonia is a common cause of morbidity and mortality in elderly patients, in particular those with advanced Alzheimer's dementia. LATUDA and other antipsychotic drugs should be used cautiously in patients at risk for aspiration pneumonia.

5.16 Neurological Adverse Reactions in Patients with Parkinson's Disease or Dementia with Lewy Bodies

Patients with Parkinson's Disease or Dementia with Lewy Bodies are reported to have an increased sensitivity to antipsychotic medication. Manifestations of this increased sensitivity include confusion, obtundation, postural instability with frequent falls, extrapyramidal symptoms, and clinical features consistent with the neuroleptic malignant syndrome.

6 ADVERSE REACTIONS

The following adverse reactions are discussed in more detail in other sections of the labeling:

- Increased Mortality in Elderly Patients with Dementia-Related Psychosis [*see Boxed Warning and Warnings and Precautions (5.1)*]
- Suicidal Thoughts and Behaviors [*see Boxed Warning and Warnings and Precautions (5.2)*]
- Cerebrovascular Adverse Reactions, Including Stroke, in Elderly Patients with Dementia-related Psychosis [*see Warnings and Precautions (5.3)*]
- Neuroleptic Malignant Syndrome [*see Warnings and Precautions (5.4)*]
- Tardive Dyskinesia [*see Warnings and Precautions (5.5)*]
- Metabolic Changes [*see Warnings and Precautions (5.6)*]
- Hyperprolactinemia [*see Warnings and Precautions (5.7)*]
- Leukopenia, Neutropenia, and Agranulocytosis [*see Warnings and Precautions (5.8)*]
- Orthostatic Hypotension and Syncope [*see Warnings and Precautions (5.9)*]
- Falls [*see Warnings and Precautions (5.10)*]
- Seizures [*see Warnings and Precautions (5.11)*]
- Potential for Cognitive and Motor Impairment [*see Warnings and Precautions (5.12)*]
- Body Temperature Dysregulation [*see Warnings and Precautions (5.13)*]
- Activation of Mania/Hypomania [*see Warnings and Precautions (5.14)*]
- Dysphagia [*see Warnings and Precautions (5.15)*]
- Neurological Adverse Reactions in Patients with Parkinson's Disease or Dementia with Lewy Bodies [*see Warnings and Precautions (5.16)*]

6.1 Clinical Trials Experience

Because clinical trials are conducted under widely varying conditions, adverse reaction rates observed in clinical trials of a drug cannot be directly compared to rates in the clinical trials of another drug and may not reflect the rates observed in clinical practice.

Adults

The information below is derived from an integrated clinical study database for LATUDA consisting of 3799 adult patients exposed to one or more doses of LATUDA for the treatment of schizophrenia, and bipolar depression in placebo-controlled studies. This experience corresponds with a total experience of 1250.9 patient-years. A total of 1106 LATUDA-treated patients had at least 24 weeks and 371 LATUDA-treated patients had at least 52 weeks of exposure.

Adverse events during exposure to study treatment were obtained by general inquiry and voluntarily reported adverse experiences, as well as results from physical examinations, vital signs, ECGs, weights and laboratory investigations. Adverse experiences were recorded by clinical investigators using their own terminology. In order to provide a meaningful estimate of the proportion of individuals experiencing adverse events, events were grouped in standardized categories using MedDRA terminology.

Schizophrenia

The following findings are based on the short-term, placebo-controlled premarketing adult studies for schizophrenia in which LATUDA was administered at daily doses ranging from 20 to 160 mg (n=1508).

Commonly Observed Adverse Reactions: The most common adverse reactions (incidence \geq 5% and at least twice the rate of placebo) in patients treated with LATUDA were somnolence, akathisia, extrapyramidal symptoms, and nausea.

Adverse Reactions Associated with Discontinuation of Treatment: A total of 9.5% (143/1508) LATUDA-treated patients and 9.3% (66/708) of placebo-treated patients discontinued due to adverse reactions. There were no adverse reactions associated with discontinuation in subjects treated with LATUDA that were at least 2% and at least twice the placebo rate.

Adverse Reactions Occurring at an Incidence of 2% or More in LATUDA-Treated Patients: Adverse reactions associated with the use of LATUDA (incidence of 2% or greater, rounded to the nearest percent and LATUDA incidence greater than placebo) that occurred during acute therapy (up to 6 weeks in patients with schizophrenia) are shown in [Table 19](#).

Table 19: Adverse Reactions in 2% or More of LATUDA-Treated Patients and That Occurred at Greater Incidence than in the Placebo-Treated Patients in Adult Short-term Schizophrenia Studies

Body System or Organ Class	Percentage of Patients Reporting Reaction						
	Placebo (N=708) (%)	20 mg/day (N=71) (%)	40 mg/day (N=487) (%)	80 mg/day (N=538) (%)	120 mg/day (N=291) (%)	160 mg/day (N=121) (%)	All LATUDA (N=1508) (%)
Gastrointestinal Disorders							
Nausea	5	11	10	9	13	7	10
Vomiting	6	7	6	9	9	7	8
Dyspepsia	5	11	6	5	8	6	6
Salivary Hypersecretion	<1	1	1	2	4	2	2
Musculoskeletal and Connective Tissue Disorders							
Back Pain	2	0	4	3	4	0	3
Nervous System Disorders							
Somnolence*	7	15	16	15	26	8	17
Akathisia	3	6	11	12	22	7	13
Extrapyramidal Disorder**	6	6	11	12	22	13	14
Dizziness	2	6	4	4	5	6	4
Psychiatric Disorders							
Insomnia	8	8	10	11	9	7	10
Agitation	4	10	7	3	6	5	5
Anxiety	4	3	6	4	7	3	5
Restlessness	1	1	3	1	3	2	2

Note: Figures rounded to the nearest integer

* Somnolence includes adverse event terms: hypersomnia, hypersomnolence, sedation, and somnolence

** Extrapyramidal symptoms include adverse event terms: bradykinesia, cogwheel rigidity, drooling, dystonia, extrapyramidal disorder, hypokinesia, muscle rigidity, oculogyric crisis, oromandibular dystonia, parkinsonism, psychomotor retardation, tongue spasm, torticollis, tremor, and trismus

Dose-Related Adverse Reactions in the Schizophrenia Studies

Akathisia and extrapyramidal symptoms were dose-related. The frequency of akathisia increased with dose up to 120 mg/day (5.6% for LATUDA 20 mg, 10.7% for LATUDA 40 mg, 12.3% for LATUDA 80 mg, and 22.0% for LATUDA 120 mg). Akathisia was reported by 7.4% (9/121) of patients receiving 160 mg/day. Akathisia occurred in 3.0% of subjects receiving placebo. The frequency of extrapyramidal symptoms increased with dose up to 120 mg/day (5.6% for LATUDA 20 mg, 11.5% for LATUDA 40 mg, 11.9% for LATUDA 80 mg, and 22.0% for LATUDA 120 mg).

Bipolar Depression (Monotherapy)

The following findings are based on the adult short-term, placebo-controlled premarketing study for bipolar depression in which LATUDA was administered at daily doses ranging from 20 to 120 mg (n=331).

Commonly Observed Adverse Reactions: The most common adverse reactions (incidence $\geq 5\%$, in either dose group, and at least twice the rate of placebo) in patients treated with LATUDA were akathisia, extrapyramidal symptoms, somnolence, nausea, vomiting, diarrhea, and anxiety.

Adverse Reactions Associated with Discontinuation of Treatment: A total of 6.0% (20/331) LATUDA-treated patients and 5.4% (9/168) of placebo-treated patients discontinued due to adverse reactions. There were no adverse reactions associated with discontinuation in subjects treated with LATUDA that were at least 2% and at least twice the placebo rate.

Adverse Reactions Occurring at an Incidence of 2% or More in LATUDA-Treated Patients: Adverse reactions associated with the use of LATUDA (incidence of 2% or greater, rounded to the nearest percent and LATUDA incidence greater than placebo) that occurred during acute therapy (up to 6 weeks in patients with bipolar depression) are shown in Table 20.

Table 20: Adverse Reactions in 2% or More of LATUDA-Treated Patients and That Occurred at Greater Incidence than in the Placebo-Treated Patients in the Adult Short-term Monotherapy Bipolar Depression Study

Body System or Organ Class Dictionary-derived Term	Percentage of Patients Reporting Reaction			
	Placebo (N=168) (%)	LATUDA 20-60 mg/day (N=164) (%)	LATUDA 80-120 mg/day (N=167) (%)	All LATUDA (N=331) (%)
Gastrointestinal Disorders				
Nausea	8	10	17	14
Dry Mouth	4	6	4	5
Vomiting	2	2	6	4
Diarrhea	2	5	3	4
Infections and Infestations				
Nasopharyngitis	1	4	4	4
Influenza	1	<1	2	2
Urinary Tract Infection	<1	2	1	2
Musculoskeletal and Connective Tissue Disorders				
Back Pain	<1	3	<1	2
Nervous System Disorders				
Extrapyramidal Symptoms*	2	5	9	7
Akathisia	2	8	11	9
Somnolence**	7	7	14	11
Psychiatric Disorders				
Anxiety	1	4	5	4

Note: Figures rounded to the nearest integer

*Extrapyramidal symptoms include adverse event terms: bradykinesia, cogwheel rigidity, drooling, dystonia, extrapyramidal disorder, glabellar reflex abnormal, hypokinesia, muscle rigidity, oculogyric crisis, oromandibular dystonia, parkinsonism, psychomotor retardation, tongue spasm, torticollis, tremor, and trismus

** Somnolence includes adverse event terms: hypersomnia, hypersomnolence, sedation, and somnolence

Dose-Related Adverse Reactions in the Monotherapy Study:

In the adult short-term, placebo-controlled study (involving lower and higher LATUDA dose ranges) [see *Clinical Studies (14.2)*] the adverse reactions that occurred with a greater than 5% incidence in the patients treated with LATUDA in any dose group and greater than placebo in both groups were nausea (10.4%, 17.4%), somnolence (7.3%, 13.8%), akathisia (7.9%, 10.8%), and extrapyramidal symptoms (4.9%, 9.0%) for LATUDA 20 to 60 mg/day and LATUDA 80 to 120 mg/day, respectively.

Bipolar Depression

Adjunctive Therapy with Lithium or Valproate

The following findings are based on two adult short-term, placebo-controlled premarketing studies for bipolar depression in which LATUDA was administered at daily doses ranging from 20 to 120 mg as adjunctive therapy with lithium or valproate (n=360).

Commonly Observed Adverse Reactions: The most common adverse reactions (incidence $\geq 5\%$ and at least twice the rate of placebo) in subjects treated with LATUDA were akathisia and somnolence.

Adverse Reactions Associated with Discontinuation of Treatment: A total of 5.8% (21/360) LATUDA-treated patients and 4.8% (16/334) of placebo-treated patients discontinued due to adverse reactions. There were no adverse reactions associated with discontinuation in subjects treated with LATUDA that were at least 2% and at least twice the placebo rate.

Adverse Reactions Occurring at an Incidence of 2% or More in LATUDA-Treated Patients: Adverse reactions associated with the use of LATUDA (incidence of 2% or greater, rounded to the nearest percent and LATUDA incidence greater than placebo) that occurred during acute therapy (up to 6 weeks in patients with bipolar depression) are shown in [Table 21](#).

Table 21: Adverse Reactions in 2% or More of LATUDA-Treated Patients and That Occurred at Greater Incidence than in the Placebo-Treated Patients in the Adult Short-term Adjunctive Therapy Bipolar Depression Studies

Body System or Organ Class Dictionary-derived Term	Percentage of Patients Reporting Reaction	
	Placebo (N=334) (%)	LATUDA 20 to 120 mg/day (N=360) (%)
Gastrointestinal Disorders		
Nausea	10	14
Vomiting	1	4
General Disorders		
Fatigue	1	3
Infections and Infestations		
Nasopharyngitis	2	4
Investigations		
Weight Increased	<1	3
Metabolism and Nutrition Disorders		
Increased Appetite	1	3
Nervous System Disorders		
Extrapyramidal Symptoms*	9	14
Somnolence**	5	11
Akathisia	5	11
Psychiatric Disorders		
Restlessness	<1	4

Note: Figures rounded to the nearest integer

*Extrapyramidal symptoms include adverse event terms: bradykinesia, cogwheel rigidity, drooling, dystonia, extrapyramidal disorder, glabellar reflex abnormal, hypokinesia, muscle rigidity, oculogyric crisis, oromandibular dystonia, parkinsonism, psychomotor retardation, tongue spasm, torticollis, tremor, and trismus

** Somnolence includes adverse event terms: hypersomnia, hypersomnolence, sedation, and somnolence

Adolescents

Schizophrenia

The following findings are based on the short-term, placebo-controlled adolescent study for schizophrenia in which LATUDA was administered at daily doses ranging from 40 (N=110) to 80 mg (N=104).

Commonly Observed Adverse Reactions: The most common adverse reactions (incidence $\geq 5\%$ and at least twice the rate of placebo) in adolescent patients (13 to 17 years) treated with LATUDA were somnolence, nausea, akathisia, extrapyramidal symptoms (non-akathisia, 40mg only), vomiting, and rhinorrhea/rhinitis (80mg only).

Adverse Reactions Associated with Discontinuation of Treatment: The incidence of discontinuation due to adverse reactions between LATUDA- and placebo-treated adolescent patients (13 to 17 years) was 4% and 8%, respectively.

Adverse Reactions Occurring at an Incidence of 2% or More in LATUDA-Treated Patients: Adverse reactions associated with the use of LATUDA (incidence of 2% or greater, rounded to the nearest percent and LATUDA incidence greater than placebo) that occurred during acute therapy (up to 6-weeks in adolescent patients with schizophrenia) are shown in Table 22.

Table 22: Adverse Reactions in 2% or More of LATUDA-Treated Patients and That Occurred at Greater Incidence than in the Placebo-Treated Patients in the Adolescent Short-term Schizophrenia Study

Body System or Organ Class Dictionary-derived Term	Percentage of Patients Reporting Reaction			
	Placebo (N=112)	LATUDA 40 mg/day (N=110)	LATUDA 80 mg/day (N=104)	All LATUDA (N=214)
Gastrointestinal Disorders				
Nausea	3	13	14	14
Vomiting	2	8	6	8
Diarrhea	1	3	5	4
Dry Mouth	0	2	3	2
Infections and Infestations				
Viral Infection **	6	11	10	10
Rhinitis ***	2	<1	8	4
Oropharyngeal pain	0	<1	3	2
Tachycardia	0	0	3	1
Nervous System Disorders				
Somnolence*	7	15	13	15
Akathisia	2	9	9	9
Dizziness	1	5	5	5

Note: Figures rounded to the nearest integer

* Somnolence includes adverse event terms: hypersomnia, sedation, and somnolence

** Viral Infection includes adverse event terms: nasopharyngitis, influenza, viral infection, upper respiratory tract infection

*** Rhinitis includes adverse event terms: rhinitis, allergic rhinitis, rhinorrhea, and nasal congestion

Pediatric Patients (10 to 17 years)

Bipolar Depression

The following findings are based on the 6-week , placebo-controlled study for bipolar depression in pediatric patients 10 to 17 years in which LATUDA was administered at daily doses ranging from 20 to 80 mg (N=175).

Commonly Observed Adverse Reactions: The most common adverse reactions (incidence $\geq 5\%$, and at least twice the rate of placebo) in pediatric patients (10 to 17 years) treated with LATUDA were nausea, weight increase, and insomnia.

Adverse Reactions Associated with Discontinuation of Treatment: The incidence of discontinuation due to adverse reactions between LATUDA- and placebo-treated pediatric patients 10 to 17 years was 2% and 2%, respectively.

Adverse Reactions Occurring at an Incidence of 2% or More in LATUDA-Treated Patients: Adverse reactions associated with the use of LATUDA (incidence of 2% or greater, rounded to the nearest percent and LATUDA incidence greater than placebo) that occurred during acute therapy (up to 6 weeks in pediatric patients with bipolar depression) are shown in Table 23.

Table 23: Adverse Reactions in 2% or More of LATUDA-Treated Patients and That Occurred at Greater Incidence than in the Placebo-Treated Patients in the 6-Week Bipolar Depression Study in Pediatric Patients (10 to 17 years)

Body System or Organ Class Dictionary-derived Term	Percentage of Patients Reporting Reaction	
	Placebo (N=172)	LATUDA 20 to 80 mg/day (N=175)
Gastrointestinal Disorders		
Nausea	6	16
Vomiting	4	6
Abdominal Pain Upper	2	3
Diarrhea	2	3
Abdominal Pain	1	3
General Disorders And Administration Site Conditions		
Fatigue	2	3
Investigations		
Weight Increased	2	7
Metabolism and Nutrition Disorders		
Decreased Appetite	2	4
Nervous System Disorders		
Somnolence*	6	11
Extrapyramidal symptoms**	5	6
Dizziness	5	6

Psychiatric Disorders		
Insomnia	2	5
Abnormal Dreams	2	2
Respiratory, Thoracic and Mediastinal Disorders		
Oropharyngeal Pain	2	2

Note: Figures rounded to the nearest integer

*Somnolence includes adverse event terms: hypersomnia, hypersomnolence, sedation, and somnolence

**EPS includes adverse event terms: akathisia, cogwheel rigidity, dyskinesia, dystonia, hyperkinesia, joint stiffness, muscle rigidity, muscle spasms, musculoskeletal stiffness, oculogyric crisis, parkinsonism, tardive dyskinesia, and tremor

Extrapyramidal Symptoms

Schizophrenia

Adults

In the short-term, placebo-controlled schizophrenia studies, for LATUDA-treated patients, the incidence of reported events related to extrapyramidal symptoms (EPS), excluding akathisia and restlessness, was 13.5% and 5.8% for placebo-treated patients. The incidence of akathisia for LATUDA-treated patients was 12.9% and 3.0% for placebo-treated patients. Incidence of EPS by dose is provided in [Table 24](#).

Table 24: Incidence of EPS Compared to Placebo in Adult Schizophrenia Studies

Adverse Event Term	Placebo (N=708) (%)	LATUDA				
		20 mg/day (N=71) (%)	40 mg/day (N=487) (%)	80 mg/day (N=538) (%)	120 mg/day (N=291) (%)	160 mg/day (N=121) (%)
All EPS events	9	10	21	23	39	20
All EPS events, excluding Akathisia/Restlessness	6	6	11	12	22	13
Akathisia	3	6	11	12	22	7
Dystonia*	<1	0	4	5	7	2
Parkinsonism**	5	6	9	8	17	11
Restlessness	1	1	3	1	3	2

Note: Figures rounded to the nearest integer

* Dystonia includes adverse event terms: dystonia, oculogyric crisis, oromandibular dystonia, tongue spasm, torticollis, and trismus

** Parkinsonism includes adverse event terms: bradykinesia, cogwheel rigidity, drooling, extrapyramidal disorder, hypokinesia, muscle rigidity, parkinsonism, psychomotor retardation, and tremor

Adolescents

In the short-term, placebo-controlled, study of schizophrenia in adolescents, the incidence of EPS, excluding events related to akathisia, for LATUDA-treated patients was higher in the 40 mg (10%)

and the 80 mg (7.7%) treatment groups vs. placebo (3.6%); and the incidence of akathisia-related events for LATUDA-treated patients was 8.9% vs. 1.8% for placebo-treated patients. Incidence of EPS by dose is provided in [Table 25](#).

Table 25: Incidence of EPS Compared to Placebo in the Adolescent Schizophrenia Study

Adverse Event Term	LATUDA		
	Placebo (N=112) (%)	40 mg/day (N=110) (%)	80 mg/day (N=104) (%)
All EPS events	5	14	14
All EPS events, excluding Akathisia/Restlessness	4	7	7
Akathisia	2	9	9
Parkinsonism**	<1	4	0
Dyskinesia	<1	<1	1
Dystonia*	0	<1	1

Note: Figures rounded to the nearest integer

* Dystonia includes adverse event terms: dystonia, trismus, oculogyric crisis, oromandibular dystonia, tongue spasm, and torticollis

** Parkinsonism includes adverse event terms: bradykinesia, drooling, extrapyramidal disorder, glabellar reflex abnormal, hypokinesia, parkinsonism, and psychomotor retardation

Bipolar Depression

Adults

Monotherapy

In the adult short-term, placebo-controlled monotherapy bipolar depression study, for LATUDA-treated patients, the incidence of reported events related to EPS, excluding akathisia and restlessness was 6.9% and 2.4% for placebo-treated patients. The incidence of akathisia for LATUDA-treated patients was 9.4% and 2.4% for placebo-treated patients. Incidence of EPS by dose groups is provided in [Table 26](#).

Table 26: Incidence of EPS Compared to Placebo in the Adult Monotherapy Bipolar Depression Study

Adverse Event Term	LATUDA		
	Placebo (N=168) (%)	20 to 60 mg/day (N=164) (%)	80 to 120 mg/day (N=167) (%)
All EPS events	5	12	20
All EPS events, excluding Akathisia/Restlessness	2	5	9
Akathisia	2	8	11
Dystonia*	0	0	2
Parkinsonism**	2	5	8
Restlessness	<1	0	3

Note: Figures rounded to the nearest integer

* Dystonia includes adverse event terms: dystonia, oculogyric crisis, oromandibular dystonia, tongue spasm, torticollis, and trismus

** Parkinsonism includes adverse event terms: bradykinesia, cogwheel rigidity, drooling, extrapyramidal disorder, glabellar reflex abnormal, hypokinesia, muscle rigidity, parkinsonism, psychomotor retardation, and tremor

Adjunctive Therapy with Lithium or Valproate

In the adult short-term, placebo-controlled adjunctive therapy bipolar depression studies, for LATUDA-treated patients, the incidence of EPS, excluding akathisia and restlessness, was 13.9% and 8.7% for placebo. The incidence of akathisia for LATUDA-treated patients was 10.8% and 4.8% for placebo-treated patients. Incidence of EPS is provided in [Table 27](#).

Table 27: Incidence of EPS Compared to Placebo in the Adult Adjunctive Therapy Bipolar Depression Studies

Adverse Event Term	Placebo (N=334) (%)	LATUDA 20 to 120 mg/day (N=360) (%)
All EPS events	13	24
All EPS events, excluding Akathisia/Restlessness	9	14
Akathisia	5	11
Dystonia*	<1	1
Parkinsonism**	8	13

Adverse Event Term	Placebo (N=334) (%)	LATUDA 20 to 120 mg/day (N=360) (%)
All EPS events	13	24
All EPS events, excluding Akathisia/Restlessness	9	14
Restlessness	<1	4

Note: Figures rounded to the nearest integer

* Dystonia includes adverse event terms: dystonia, oculogyric crisis, oromandibular dystonia, tongue spasm, torticollis, and trismus

** Parkinsonism includes adverse event terms: bradykinesia, cogwheel rigidity, drooling, extrapyramidal disorder, glabellar reflex abnormal, hypokinesia, muscle rigidity, parkinsonism, psychomotor retardation, and tremor

In the short-term, placebo-controlled schizophrenia and bipolar depression studies, data was objectively collected on the Simpson Angus Rating Scale (SAS) for extrapyramidal symptoms (EPS), the Barnes Akathisia Scale (BAS) for akathisia and the Abnormal Involuntary Movement Scale (AIMS) for dyskinesias.

Pediatric Patients (10 to 17 years)

In the 6-week, placebo-controlled study of bipolar depression in pediatric patients 10 to 17 years, the incidence of EPS, excluding events related to akathisia, for LATUDA-treated patients was similar in the LATUDA 20 to 80 mg/day (3.4%) treatment group vs. placebo (3.5%); and the incidence of akathisia-related events for LATUDA-treated patients was 2.9% vs. 3.5% for placebo-treated patients. Incidence of EPS by dose is provided in [Table 28](#).

Table 28: Incidence of EPS Compared to Placebo in the Bipolar Depression Study in Pediatric Patients (10 to 17 years)

Adverse Event Term	Placebo (N=172) (%)	LATUDA 20 to 80 mg/day (N=175) (%)
All EPS events*	5	6
All EPS events, excluding Akathisia/Restlessness	4	3
Akathisia	4	3
Parkinsonism**	<1	<1
Dystonia***	1	<1
Salivary hypersecretion	<1	<1
Psychomotor hyperactivity	0	<1
Tardive Dyskinesia	<1	0

Adverse Event Term	Placebo (N=172) (%)	LATUDA 20 to 80 mg/day (N=175) (%)
All EPS events*	5	6
All EPS events, excluding Akathisia/Restlessness	4	3

Note: Figures rounded to the nearest integer

* EPS include adverse event terms: akathisia, cogwheel rigidity, dyskinesia, dystonia, hyperkinesia, joint stiffness, muscle rigidity, muscle spasms, musculoskeletal stiffness, oculogyric crisis, parkinsonism, tardive dyskinesia, and tremor

** Parkinsonism includes adverse event terms: bradykinesia, drooling, extrapyramidal disorder, glabellar reflex abnormal, hypokinesia, parkinsonism, and psychomotor retardation

***Dystonia includes adverse event terms: dystonia, oculogyric crisis, oromandibular dystonia, tongue spasm, torticollis, and trismus

Schizophrenia

Adults

The mean change from baseline for LATUDA-treated patients for the SAS, BAS and AIMS was comparable to placebo-treated patients, with the exception of the Barnes Akathisia Scale global score (LATUDA, 0.1; placebo, 0.0). The percentage of patients who shifted from normal to abnormal was greater in LATUDA-treated patients and placebo for the BAS (LATUDA, 14.4%; placebo, 7.1%), the SAS (LATUDA, 5.0%; placebo, 2.3%) and the AIMS (LATUDA, 7.4%; placebo, 5.8%).

Adolescents

The mean change from baseline for LATUDA- treated patients with adolescent schizophrenia for the SAS, BAS and AIMS was comparable to placebo-treated patients. The percentage of patients who shifted from normal to abnormal was greater in LATUDA-treated patients and placebo for the BAS (LATUDA, 7.0%; placebo, 1.8%), the SAS (LATUDA, 8.3%; placebo, 2.7%) and the AIMS (LATUDA, 2.8%; placebo, 0.9%).

Bipolar Depression

Adults

Monotherapy

The mean change from baseline for LATUDA-treated adult patients for the SAS, BAS and AIMS was comparable to placebo-treated patients. The percentage of patients who shifted from normal to abnormal was greater in LATUDA-treated patients and placebo for the BAS (LATUDA, 8.4%; placebo, 5.6%), the SAS (LATUDA, 3.7%; placebo, 1.9%) and the AIMS (LATUDA, 3.4%; placebo, 1.2%).

Adjunctive Therapy with Lithium or Valproate

The mean change from baseline for LATUDA-treated adult patients for the SAS, BAS and AIMS was comparable to placebo-treated patients. The percentage of patients who shifted from normal to abnormal was greater in LATUDA-treated patients and placebo for the BAS (LATUDA, 8.7%;

placebo, 2.1%), the SAS (LATUDA, 2.8%; placebo, 2.1%) and the AIMS (LATUDA, 2.8%; placebo, 0.6%).

Pediatric Patients (10 to 17 years)

The mean change from baseline for LATUDA- treated pediatric patients 10 to 17 years with bipolar depression for the SAS, BAS and AIMS was comparable to placebo-treated patients. The percentage of patients who shifted from normal to abnormal was greater in LATUDA-treated patients and placebo for the BAS (LATUDA, 4.6%; placebo, 2.4%), the SAS (LATUDA, 0.6%; placebo, 0%) and was the same for the AIMS (LATUDA, 0%; placebo, 0%).

Dystonia

Class Effect: Symptoms of dystonia, prolonged abnormal contractions of muscle groups, may occur in susceptible individuals during the first few days of treatment. Dystonic symptoms include: spasm of the neck muscles, sometimes progressing to tightness of the throat, swallowing difficulty, difficulty breathing, and/or protrusion of the tongue. While these symptoms can occur at low doses, they occur more frequently and with greater severity with high potency and at higher doses of first-generation antipsychotic drugs. An elevated risk of acute dystonia is observed in males and younger age groups.

Schizophrenia

Adults

In the short-term, placebo-controlled schizophrenia clinical studies, dystonia occurred in 4.2% of LATUDA-treated subjects (0.0% LATUDA 20 mg, 3.5% LATUDA 40 mg, 4.5% LATUDA 80 mg, 6.5% LATUDA 120 mg and 2.5% LATUDA 160 mg) compared to 0.8% of subjects receiving placebo. Seven subjects (0.5%, 7/1508) discontinued clinical trials due to dystonic events – four were receiving LATUDA 80 mg/day and three were receiving LATUDA 120 mg/day.

Adolescents

In the short-term, placebo-controlled, adolescent schizophrenia study, dystonia occurred in 1% of LATUDA-treated patients (1% LATUDA 40 mg and 1% LATUDA 80 mg) compared to 0% of patients receiving placebo. No patients discontinued the clinical study due to dystonic events.

Bipolar Depression

Adults

Monotherapy

In the adult short-term, flexible-dose, placebo-controlled monotherapy bipolar depression study, dystonia occurred in 0.9% of LATUDA-treated subjects (0.0% and 1.8% for LATUDA 20 to 60 mg/day and LATUDA 80 to 120 mg/day, respectively) compared to 0.0% of subjects receiving placebo. No subject discontinued the clinical study due to dystonic events.

Adjunctive Therapy with Lithium or Valproate

In the adult short-term, flexible-dose, placebo-controlled adjunctive therapy bipolar depression studies, dystonia occurred in 1.1% of LATUDA-treated subjects (20 to 120 mg) compared to 0.6% of subjects receiving placebo. No subject discontinued the clinical study due to dystonic events.

Pediatric Patients (10 to 17 years)

In the 6-week, placebo-controlled bipolar depression study in pediatric patients 10 to 17 years, dystonia occurred in 0.6% of LATUDA-treated patients compared to 1.2% of patients receiving placebo. No patients discontinued the clinical study due to dystonic events.

Other Adverse Reactions Observed During the Premarketing Evaluation of LATUDA

Following is a list of adverse reactions reported by adult patients treated with LATUDA at multiple doses of ≥ 20 mg once daily within the premarketing database of 2905 patients with schizophrenia. The reactions listed are those that could be of clinical importance, as well as reactions that are plausibly drug-related on pharmacologic or other grounds. Reactions listed in [Table 19](#) or those that appear elsewhere in the LATUDA label are not included.

Reactions are further categorized by organ class and listed in order of decreasing frequency according to the following definitions: those occurring in at least 1/100 patients (frequent) (only those not already listed in the tabulated results from placebo-controlled studies appear in this listing); those occurring in 1/100 to 1/1000 patients (infrequent); and those occurring in fewer than 1/1000 patients (rare).

*Blood and Lymphatic System Disorders: **Infrequent:** anemia*

*Cardiac Disorders: **Frequent:** tachycardia; **Infrequent:** AV block 1st degree, angina pectoris, bradycardia*

*Ear and Labyrinth Disorders: **Infrequent:** vertigo*

*Eye Disorders: **Frequent:** blurred vision*

*Gastrointestinal Disorders: **Frequent:** abdominal pain, diarrhea; **Infrequent:** gastritis*

*General Disorders and Administrative Site Conditions: **Rare:** sudden death*

*Investigations: **Frequent:** CPK increased*

*Metabolism and Nutritional System Disorders: **Frequent:** decreased appetite*

*Musculoskeletal and Connective Tissue Disorders: **Rare:** rhabdomyolysis*

*Nervous System Disorders: **Infrequent:** cerebrovascular accident, dysarthria*

*Psychiatric Disorders: **Infrequent:** abnormal dreams, panic attack, sleep disorder*

*Renal and Urinary Disorders: **Infrequent:** dysuria; **Rare:** renal failure*

*Reproductive System and Breast Disorders: **Infrequent:** amenorrhea, dysmenorrhea; **Rare:** breast enlargement, breast pain, galactorrhea, erectile dysfunction, priapism*

*Skin and Subcutaneous Tissue Disorders: **Frequent:** rash, pruritus; **Rare:** angioedema*

*Vascular Disorders: **Frequent:** hypertension*

Clinical Laboratory Changes

Schizophrenia

Adults

Serum Creatinine: In short-term, placebo-controlled trials, the mean change from Baseline in serum creatinine was +0.05 mg/dL for LATUDA-treated patients compared to +0.02 mg/dL for placebo-treated patients. A creatinine shift from normal to high occurred in 3.0% (43/1453) of

LATUDA-treated patients and 1.6% (11/681) on placebo. The threshold for high creatinine value varied from > 0.79 to > 1.3 mg/dL based on the centralized laboratory definition for each study (Table 29).

Table 29: Serum Creatinine Shifts from Normal at Baseline to High at Study End-Point in Adult Schizophrenia Studies

Laboratory Parameter	Placebo (N=708)	LATUDA 20 mg/day (N=71)	LATUDA 40 mg/day (N=487)	LATUDA 80 mg/day (N=538)	LATUDA 120 mg/day (N=291)	LATUDA 160 mg/day (N=121)
Serum Creatinine Elevated	2%	1%	2%	2%	5%	7%

Adolescents

Serum Creatinine: In the short-term, placebo-controlled, adolescent schizophrenia study, the mean change from Baseline in serum creatinine was -0.009 mg/dL for LATUDA-treated patients compared to +0.017 mg/dL for placebo-treated patients. A creatinine shift from normal to high (based on the centralized laboratory definition) occurred in 7.2% (14/194) of LATUDA-treated patients and 2.9% (3/103) on placebo (Table 30).

Table 30: Serum Creatinine Shifts from Normal at Baseline to High at Study End-Point in the Adolescent Schizophrenia Study

Laboratory Parameter	Placebo (N=103)	LATUDA 40 mg/day (N=97)	LATUDA 80 mg/day (N=97)
Serum Creatinine Elevated	2.9%	7.2%	7.2%

Bipolar Depression

Adults

Monotherapy

Serum Creatinine: In the adult short-term, flexible-dose, placebo-controlled monotherapy bipolar depression study, the mean change from Baseline in serum creatinine was +0.01 mg/dL for LATUDA-treated patients compared to -0.02 mg/dL for placebo-treated patients. A creatinine shift from normal to high occurred in 2.8% (9/322) of LATUDA-treated patients and 0.6% (1/162) on placebo (Table 31).

Table 31: Serum Creatinine Shifts from Normal at Baseline to High at Study End-Point in the Adult Monotherapy Bipolar Depression Study

Laboratory Parameter	Placebo (N=168)	LATUDA 20 to 60 mg/day (N=164)	LATUDA 80 to 120 mg/day (N=167)
Serum Creatinine Elevated	<1%	2%	4%

Adjunctive Therapy with Lithium or Valproate

Serum Creatinine: In adult short-term, placebo-controlled premarketing adjunctive-studies for bipolar depression, the mean change from Baseline in serum creatinine was +0.04 mg/dL for LATUDA-treated patients compared to -0.01 mg/dL for placebo-treated patients. A creatinine shift from normal to high occurred in 4.3% (15/360) of LATUDA-treated patients and 1.6% (5/334) on placebo (Table 32).

Table 32: Serum Creatinine Shifts from Normal at Baseline to High at Study End-Point in the Adult Adjunctive Therapy Bipolar Depression Studies

Laboratory Parameter	Placebo (N=334)	LATUDA 20 to 120 mg/day (N=360)
Serum Creatinine Elevated	2%	4%

Pediatric Patients (10 to 17 years)

Serum Creatinine: In the 6-week, placebo-controlled bipolar depression study in pediatric patients 10 to 17 years, the mean change from Baseline in serum creatinine was +0.021 mg/dL for LATUDA-treated patients compared to +0.009 mg/dL for placebo-treated patients. A creatinine shift from normal to high (based on the centralized laboratory definition) occurred in 6.7% (11/163) of LATUDA-treated patients and 4.5% (7/155) on placebo (Table 33).

Table 33: Serum Creatinine Shifts from Normal at Baseline to High at Study End-Point in the Bipolar Depression Study in Pediatric Patients (10 to 17 years)

Laboratory Parameter	Placebo (N=155)	LATUDA 20 to 80 mg/day (N=163)
Serum Creatinine Elevated	4.5%	6.7%

Pediatric Patients (6 to 17 years)

In a 104-week, open-label study in pediatric patients with schizophrenia, bipolar depression, or autistic disorder, the mean change from baseline to Week 104 in serum creatinine was +0.07

mg/dL. In patients with a normal serum creatinine at baseline, 6% experienced a shift to high at endpoint

6.2 Postmarketing Experience

The following adverse reactions have been identified during postapproval use of LATUDA. Because these reactions are reported voluntarily from a population of uncertain size, it is not always possible to reliably estimate their frequency or establish a causal relationship to drug exposure.

Hypersensitivity Reactions: Urticaria, throat swelling, tongue swelling, dyspnea, and rash.

Metabolism and Nutrition Disorders: Hyponatremia

7 DRUG INTERACTIONS

7.1 Drugs Having Clinically Important Interactions with LATUDA

Table 34: Clinically Important Drug Interactions with LATUDA

Strong CYP3A4 Inhibitors	
Clinical Impact:	Concomitant use of LATUDA with strong CYP3A4 inhibitors increased the exposure of lurasidone compared to the use of LATUDA alone [see <i>Clinical Pharmacology (12.3)</i>].
Intervention:	LATUDA should not be used concomitantly with strong CYP3A4 inhibitors [see <i>Contraindications (4)</i>].
Examples:	Ketoconazole, clarithromycin, ritonavir, voriconazole, mibefradil
Moderate CYP3A4 Inhibitors	
Clinical Impact:	Concomitant use of LATUDA with moderate CYP3A4 inhibitors increased the exposure of lurasidone compared to the use of LATUDA alone [see <i>Clinical Pharmacology (12.3)</i>].
Intervention:	LATUDA dose should be reduced to half of the original level when used concomitantly with moderate inhibitors of CYP3A4 [see <i>Dosage and Administration (2.6)</i>].
Examples:	Diltiazem, atazanavir, erythromycin, fluconazole, verapamil
Strong CYP3A4 Inducers	
Clinical Impact:	Concomitant use of LATUDA with strong CYP3A4 inducers decreased the exposure of lurasidone compared to the use of LATUDA alone [see <i>Clinical Pharmacology (12.3)</i>].
Intervention:	LATUDA should not be used concomitantly with strong CYP3A4 inducers [see <i>Contraindications (4)</i>].
Examples:	Rifampin, avasimibe, St. John's wort, phenytoin, carbamazepine
Moderate CYP3A4 Inducers	
Clinical Impact:	Concomitant use of LATUDA with moderate CYP3A4 inducers decreased the exposure of lurasidone compared to the use of LATUDA alone [see <i>Clinical Pharmacology (12.3)</i>].
Intervention:	LATUDA dose should be increased when used concomitantly with moderate inducers of CYP3A4 [see <i>Dosage and Administration (2.6)</i>].
Examples:	Bosentan, efavirenz, etravirine, modafinil, nafcillin

7.2 Drugs Having No Clinically Important Interactions with LATUDA

Based on pharmacokinetic studies, no dosage adjustment of LATUDA is required when administered concomitantly with lithium, valproate, or substrates of P-gp or CYP3A4 [see *Clinical Pharmacology (12.3)*].

8 USE IN SPECIFIC POPULATIONS

8.1 Pregnancy

Pregnancy Exposure Registry

There is a pregnancy exposure registry that monitors pregnancy outcomes in women exposed to LATUDA during pregnancy. For more information, contact the National Pregnancy Registry for Atypical Antipsychotics at 1-866-961-2388 or visit <http://womensmentalhealth.org/clinical-and-research-programs/pregnancyregistry/>.

Risk Summary

Neonates exposed to antipsychotic drugs during the third trimester of pregnancy are at risk for extrapyramidal and/or withdrawal symptoms following delivery [see *Clinical Considerations*]. There are no studies of LATUDA use in pregnant women. The limited available data are not sufficient to inform a drug-associated risk of birth defects or miscarriage. In animal reproduction studies, no teratogenic effects were seen in pregnant rats and rabbits given lurasidone during the period of organogenesis at doses approximately 1.5- and 6-times, the maximum recommended human dose (MRHD) of 160 mg/day, respectively based on mg/m² body surface area [see *Data*].

The estimated background risk of major birth defects and miscarriage for the indicated population(s) is unknown. All pregnancies have a background risk of birth defect, loss or other adverse outcomes. In the U.S. general population, the estimated background risk of major birth defects and miscarriage in clinically recognized pregnancies is 2-4% and 15-20%, respectively.

Clinical Considerations

Fetal/Neonatal Adverse Reactions

Extrapyramidal and/or withdrawal symptoms, including agitation, hypertonia, hypotonia, tremor, somnolence, respiratory distress and feeding disorder have been reported in neonates who were exposed to antipsychotic drugs during the third trimester of pregnancy. These symptoms have varied in severity. Some neonates recovered within hours or days without specific treatment; others required prolonged hospitalization. Monitor neonates for extrapyramidal and/or withdrawal symptoms and manage symptoms appropriately.

Data

Animal Data

Pregnant rats were treated with oral lurasidone at doses of 3, 10, and 25 mg/kg/day during the period of organogenesis. These doses are 0.2, 0.6, and 1.5 times the MRHD of 160 mg/day based on mg/m² body surface area. No teratogenic or embryo-fetal effects were observed up to 1.5 times the MRHD of 160 mg/day, based on mg/m².

Pregnant rabbits were treated with oral lurasidone at doses of 2, 10, and 50 mg/kg/day during the period of organogenesis. These doses are 0.2, 1.2 and 6 times the MRHD of 160 mg/day based on mg/m². No teratogenic or embryo-fetal effects were observed up to 6 times the MRHD of 160 mg/day based on mg/m².

Pregnant rats were treated with oral lurasidone at doses of 0.4, 2, and 10 mg/kg/day during the periods of organogenesis and lactation. These doses are 0.02, 0.1 and 0.6 times the MRHD of 160 mg/day based on mg/m². No pre- and postnatal developmental effects were observed up to 0.6 times the MRHD of 160 mg/day, based on mg/m².

8.2 Lactation

Risk Summary

Lactation studies have not been conducted to assess the presence of lurasidone in human milk, the effects on the breastfed infant, or the effects on milk production. Lurasidone is present in rat milk. The development and health benefits of breastfeeding should be considered along with the mother's clinical need for LATUDA and any potential adverse effects on the breastfed infant from LATUDA or from the underlying maternal condition.

8.4 Pediatric Use

Schizophrenia

The safety and effectiveness of LATUDA 40-mg/day and 80-mg/day for the treatment of schizophrenia in adolescents (13 to 17 years) was established in a 6-week, placebo-controlled clinical study in 326 adolescent patients [see *Dosage and Administration (2.1)*, *Adverse Reactions (6.1)*, and *Clinical Studies (14.1)*].

The safety and effectiveness of LATUDA has not been established in pediatric patients less than 13 years of age with schizophrenia.

Bipolar Depression

The safety and effectiveness of LATUDA 20 to 80 mg/day for the treatment of bipolar depression in pediatric patients (10 to 17 years) was established in a 6-week, placebo-controlled clinical study in 347 pediatric patients [see *Dosage and Administration (2.2)*, *Adverse Reactions (6.1)*, and *Clinical Studies (14.2)*].

The safety and effectiveness of LATUDA has not been established in pediatric patients less than 10 years of age with bipolar depression.

Irritability Associated with Autistic Disorder

The effectiveness of LATUDA in pediatric patients for the treatment of irritability associated with autistic disorder has not been established.

Efficacy was not demonstrated in a 6-week study evaluating LATUDA 20 mg/day and 60 mg/day for the treatment of pediatric patients 6 to 17 years of age with irritability associated with autistic disorder diagnosed by Diagnostic and Statistical Manual of Mental Disorders, 4th Ed., Text Revision [DSM-IV-TR] criteria. The primary objective of the study as measured by improvement from Baseline in the irritability subscale of the Aberrant Behavior Checklist (ABC) at Endpoint (Week 6) was not met. A total of 149 patients were randomized to LATUDA or placebo. Vomiting occurred at a higher rate than reported in other LATUDA studies (4/49 or 8% for 20mg, 14/51 or 27% for 60mg, and 2/49 or 4% for placebo), particularly in children ages 6 to 12 (13 out of 18 patients on LATUDA with vomiting).

In a long-term, open-label study that enrolled pediatric patients (age 6 to 17 years) with schizophrenia, bipolar depression, or autistic disorder from three short-term, placebo-controlled trials, 54% (378/701) received lurasidone for 104 weeks. There was one adverse event in this trial that was considered possibly drug-related and has not been reported in adults receiving lurasidone: a 10 year old male experienced a prolonged, painful erection, consistent with priapism, that led to treatment discontinuation.

In this trial, the mean increase in height from open-label baseline to Week 104 was 4.94 cm. To adjust for normal growth, z-scores were derived (measured in standard deviations [SD]), which normalize for the natural growth of children and adolescents by comparisons to age- and sex-matched population standards. A z-score change <0.5 SD is considered not clinically significant. In this trial, the mean change in height z-score from open-label baseline to Week 104 was $+0.05$ SD, indicating minimal deviation from the normal growth curve.

Juvenile animal studies

Adverse effects were seen on growth, physical and neurobehavioral development at doses as low as 0.2 times the MRHD based on mg/m^2 . Lurasidone was orally administered to rats from postnatal days 21 through 91 (this period corresponds to childhood, adolescence, and young adulthood in humans) at doses of 3, 30, and 150 (males) or 300 (females) $\text{mg}/\text{kg}/\text{day}$ which are 0.2 to 10 times (males) and 20 times (females) the maximum recommended adult human dose (MRHD) of 160 mg/day based on mg/m^2 . The adverse effects included dose-dependent decreases in femoral length, bone mineral content, body and brain weights at 2 times the MRHD in both sexes, and motor hyperactivity at 0.2 and 2 times the MRHD in both sexes based on mg/m^2 . In females, there was a delay in attainment of sexual maturity at 2 times the MRHD, associated with decreased serum estradiol. Mortality occurred in both sexes during early post-weaning period and some of the male weanlings died after only 4 treatments at doses as low as 2 times the MRHD based on mg/m^2 . Histopathological findings included increased colloid in the thyroids and inflammation of the prostate in males at 10 times MRHD based on mg/m^2 and mammary gland hyperplasia, increased vaginal mucification, and increased ovarian atretic follicles at doses as low as 0.2 times the MRHD based on mg/m^2 . Some of these findings were attributed to transiently elevated serum prolactin which was seen in both sexes at all doses. However, there were no changes at any dose level in reproductive parameters (fertility, conception indices, spermatogenesis, estrous cycle, gestation length, parturition, number of pups born). The no effect dose for neurobehavioral changes in males is 0.2 times the MRHD based on mg/m^2 and could not be determined in females. The no effect dose for growth and physical development in both sexes is 0.2 times the MRHD based on mg/m^2 .

8.5 Geriatric Use

Clinical studies with LATUDA did not include sufficient numbers of patients aged 65 and older to determine whether or not they respond differently from younger patients. In elderly patients with psychosis (65 to 85), LATUDA concentrations (20 mg/day) were similar to those in young subjects. It is unknown whether dose adjustment is necessary on the basis of age alone.

Elderly patients with dementia-related psychosis treated with LATUDA are at an increased risk of death compared to placebo. LATUDA is not approved for the treatment of patients with dementia-related psychosis [*see Boxed Warning, Warnings and Precautions (5.1, 5.3)*].

8.6 Renal Impairment

Reduce the maximum recommended dosage in patients with moderate or severe renal impairment ($\text{CL}_{\text{Cr}} < 50$ mL/minute). Patients with impaired renal function ($\text{CL}_{\text{Cr}} < 50$ mL/minute) had higher exposure to lurasidone than patients with normal renal function [*see Clinical Pharmacology (12.3)*]. Greater exposure may increase the risk of LATUDA-associated adverse reactions [*see Dosage and Administration (2.4)*].

8.7 Hepatic Impairment

Reduce the maximum recommended dosage in patients with moderate to severe hepatic impairment (Child-Pugh score ≥ 7). Patients with moderate to severe hepatic impairment (Child-Pugh score ≥ 7) generally had higher exposure to lurasidone than patients with normal hepatic function [see *Clinical Pharmacology* (12.3)]. Greater exposure may increase the risk of LATUDA-associated adverse reactions [see *Dosage and Administration* (2.5)].

8.8 Other Specific Populations

No dosage adjustment for LATUDA is required on the basis of a patient's sex, race, or smoking status [see *Clinical Pharmacology* (12.3)].

9 DRUG ABUSE AND DEPENDENCE

9.1 Controlled Substance

LATUDA is not a controlled substance.

9.2 Abuse

LATUDA has not been systematically studied in humans for its potential for abuse or physical dependence or its ability to induce tolerance. While clinical studies with LATUDA did not reveal any tendency for drug-seeking behavior, these observations were not systematic and it is not possible to predict the extent to which a CNS-active drug will be misused, diverted and/or abused once it is marketed. Patients should be evaluated carefully for a history of drug abuse, and such patients should be observed carefully for signs of LATUDA misuse or abuse (e.g., development of tolerance, drug-seeking behavior, increases in dose).

10 OVERDOSAGE

10.1 Human Experience

In premarketing clinical studies, accidental or intentional overdosage of LATUDA was identified in one patient who ingested an estimated 560 mg of LATUDA. This patient recovered without sequelae. This patient resumed LATUDA treatment for an additional two months.

10.2 Management of Overdosage

No specific antidotes for LATUDA are known. In managing overdose, provide supportive care, including close medical supervision and monitoring, and consider the possibility of multiple drug involvement. If an overdose occurs, consult a Certified Poison Control Center (1-800-222-1222 or www.poison.org).

Cardiovascular monitoring should commence immediately, including continuous electrocardiographic monitoring for possible arrhythmias. If antiarrhythmic therapy is administered, disopyramide, procainamide, and quinidine carry a theoretical hazard of additive QT-prolonging effects when administered in patients with an acute overdose of LATUDA.

Similarly, the alpha-blocking properties of bretylium might be additive to those of LATUDA, resulting in problematic hypotension.

Hypotension and circulatory collapse should be treated with appropriate measures. Epinephrine and dopamine should not be used, or other sympathomimetics with beta-agonist activity, since beta stimulation may worsen hypotension in the setting of LATUDA-induced alpha blockade. In case of severe extrapyramidal symptoms, anticholinergic medication should be administered.

Gastric lavage (after intubation if patient is unconscious) and administration of activated charcoal together with a laxative should be considered.

The possibility of obtundation, seizures, or dystonic reaction of the head and neck following overdose may create a risk of aspiration with induced emesis.

11 DESCRIPTION

LATUDA is an atypical antipsychotic belonging to the chemical class of benzisothiazol derivatives.

Its chemical name is (3a*R*,4*S*,7*R*,7a*S*)-2-{(1*R*,2*R*)-2-[4-(1,2-benzisothiazol-3-yl)piperazin-1-ylmethyl] cyclohexylmethyl}hexahydro-4,7-methano-2*H*-isoindole-1,3-dione hydrochloride. Its molecular formula is C₂₈H₃₆N₄O₂S·HCl and its molecular weight is 529.14.

The chemical structure is:

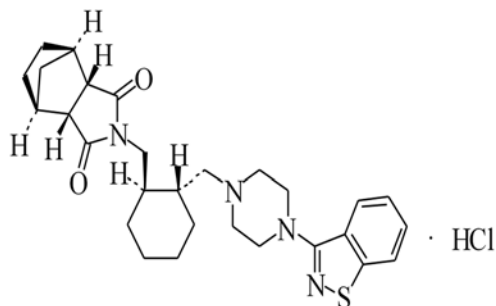

Lurasidone hydrochloride is a white to off-white powder. It is very slightly soluble in water, practically insoluble or insoluble in 0.1 N HCl, slightly soluble in ethanol, sparingly soluble in methanol, practically insoluble or insoluble in toluene and very slightly soluble in acetone.

LATUDA tablets are intended for oral administration only. Each tablet contains 20 mg, 40 mg, 60 mg, 80 mg, or 120 mg of lurasidone hydrochloride.

Inactive ingredients are mannitol, pregelatinized starch, croscarmellose sodium, hypromellose, magnesium stearate, Opadry® and carnauba wax. Additionally, the 80 mg tablet contains yellow ferric oxide and FD&C Blue No. 2 Aluminum Lake.

12 CLINICAL PHARMACOLOGY

12.1 Mechanism of Action

The mechanism of action of lurasidone in the treatment of schizophrenia and bipolar depression is unclear. However, its efficacy in schizophrenia and bipolar depression could be mediated through a combination of central dopamine D₂ and serotonin Type 2 (5HT_{2A}) receptor antagonism.

12.2 Pharmacodynamics

Lurasidone is an antagonist with high affinity binding at the dopamine D₂ receptors (K_i of 1 nM) and the serotonin 5-HT_{2A} (K_i of 0.5 nM) and 5-HT₇ (K_i of 0.5 nM) receptors. It also binds with moderate affinity to the human α_{2C} adrenergic receptors (K_i of 11 nM), is a partial agonist at serotonin 5-HT_{1A} (K_i of 6.4 nM) receptors, and is an antagonist at the α_{2A} adrenergic receptors (K_i of 41 nM). Lurasidone exhibits little or no affinity for histamine H₁ and muscarinic M₁ receptors (IC₅₀ > 1,000 nM).

ECG Changes

The effects of LATUDA on the QTc interval were evaluated in a randomized, double-blind, multiple-dose, parallel-dedicated thorough QT study in 43 patients with schizophrenia or schizoaffective disorder, who were treated with LATUDA doses of 120 mg daily, 600 mg daily and completed the study. The maximum mean (upper 1-sided, 95% CI) increase in baseline-adjusted QTc intervals based on individual correction method (QTcI) was 7.5 (11.7) ms and 4.6 (9.5) ms, for the 120 mg and 600 mg dose groups respectively, observed at 2 to 4 hours after dosing. In this study, there was no apparent dose (exposure)-response relationship.

In short-term, placebo-controlled studies in schizophrenia and bipolar depression, no post-baseline QT prolongations exceeding 500 msec were reported in patients treated with LATUDA or placebo.

12.3 Pharmacokinetics

Adults

The activity of LATUDA is primarily due to the parent drug. The pharmacokinetics of LATUDA is dose-proportional within a total daily dose range of 20 mg to 160 mg. Steady-state concentrations of LATUDA are reached within 7 days of starting LATUDA.

Following administration of 40 mg of LATUDA, the mean (%CV) elimination half-life was 18 (7) hours.

Absorption and Distribution: LATUDA is absorbed and reaches peak serum concentrations in approximately 1-3 hours. It is estimated that 9-19% of an administered dose is absorbed. Following administration of 40 mg of LATUDA, the mean (%CV) apparent volume of distribution was 6173 (17.2) L. LATUDA is highly bound (~99%) to serum proteins.

In a food effect study, LATUDA mean C_{max} and AUC were about 3-times and 2-times, respectively, when administered with food compared to the levels observed under fasting conditions. LATUDA exposure was not affected as meal size was increased from 350 to 1000 calories and was independent of meal fat content [see *Dosage and Administration (2.3)*].

In clinical studies, establishing the safety and efficacy of LATUDA, patients were instructed to take their daily dose with food [see *Dosage and Administration (2.3)*].

Metabolism and Elimination: LATUDA is metabolized mainly via CYP3A4. The major biotransformation pathways are oxidative *N*-dealkylation, hydroxylation of norbornane ring, and *S*-oxidation. LATUDA is metabolized into two active metabolites (ID-14283 and ID-14326) and two major non-active metabolites (ID-20219 and ID-20220). Based on *in vitro* studies, LATUDA is not a substrate of CYP1A1, CYP1A2, CYP2A6, CYP4A11, CYP2B6, CYP2C8, CYP2C9, CYP2C19, CYP2D6 or CYP2E1 enzymes. Because LATUDA is not a substrate for CYP1A2, smoking is not expected to have an effect on the pharmacokinetics of LATUDA.

Transporter proteins: *In vitro* studies suggest LATUDA is not a substrate of OATP1B1 or OATP1B3, however, is probably a substrate of P-gp and BCRP. *In vitro* studies indicate that LATUDA is not expected to inhibit transporters OATP1B1, OATP1B3, OCT1, OCT2, OAT1, OAT3, MATE1, MATE2-K and BSEP at clinically relevant concentrations. LATUDA is not a clinically significant inhibitor of P-gp. However, it may inhibit BCRP.

Total excretion of radioactivity in urine and feces combined was approximately 89%, with about 80% recovered in feces and 9% recovered in urine, after a single dose of [¹⁴C]-labeled LATUDA.

Following administration of 40 mg of LATUDA, the mean (%CV) apparent clearance was 3902 (18.0) mL/min.

Drug Interaction Studies

Effects of other drugs on the exposure of lurasidone are summarized in Figure 5. A population PK analyses concluded that coadministration of lithium 300-2400 mg/day or valproate 300-2000 mg/day with lurasidone for up to 6 weeks has minimal effect on lurasidone exposure.

And the effects of LATUDA on the exposures of other drugs are summarized in Figure 2. A population PK analyses concluded that coadministration of lurasidone has minimal effect on lithium and valproate exposure when it is coadministered with lithium 300-2400 mg/day or valproate 300-2000 mg/day.

Figure 1: Impact of Other Drugs on LATUDA Pharmacokinetics

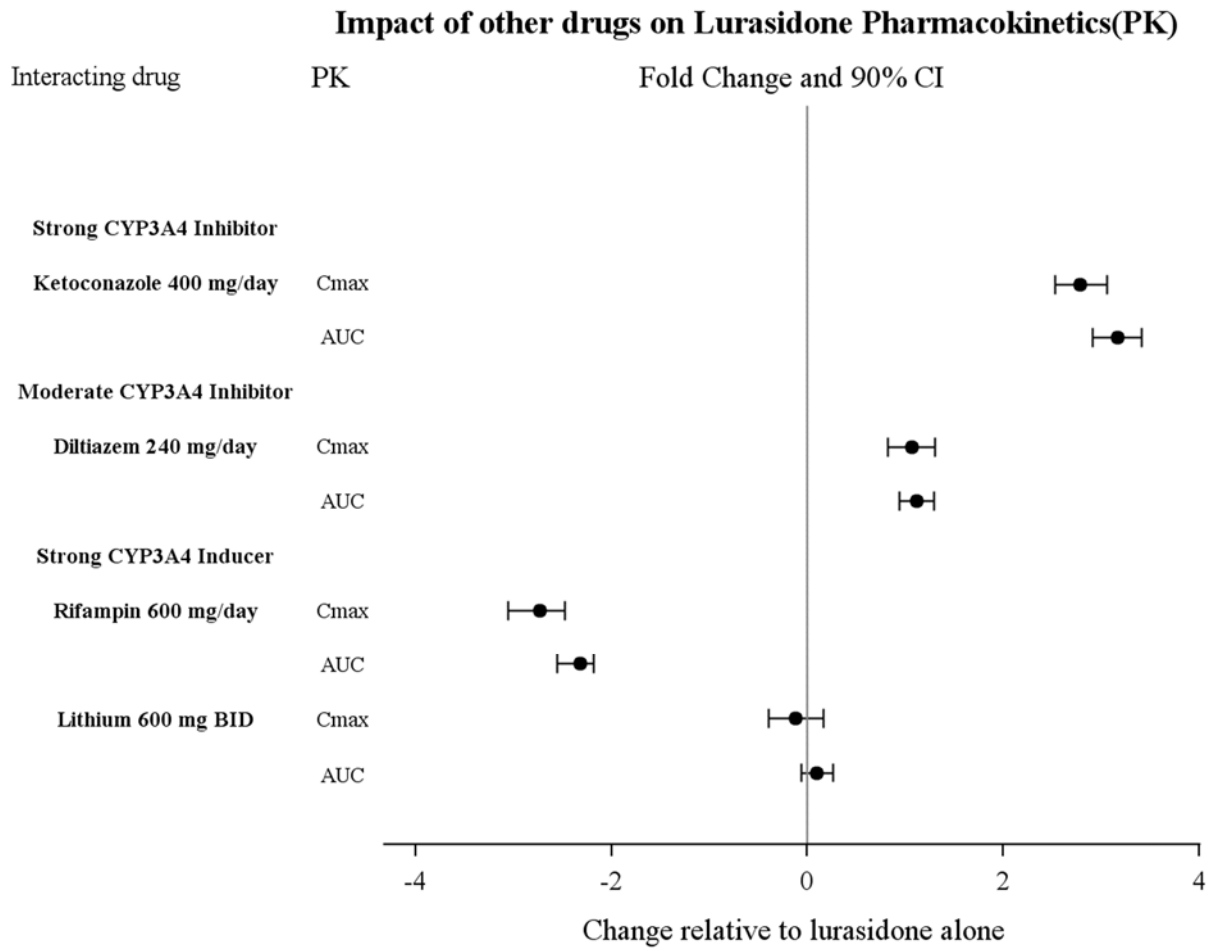
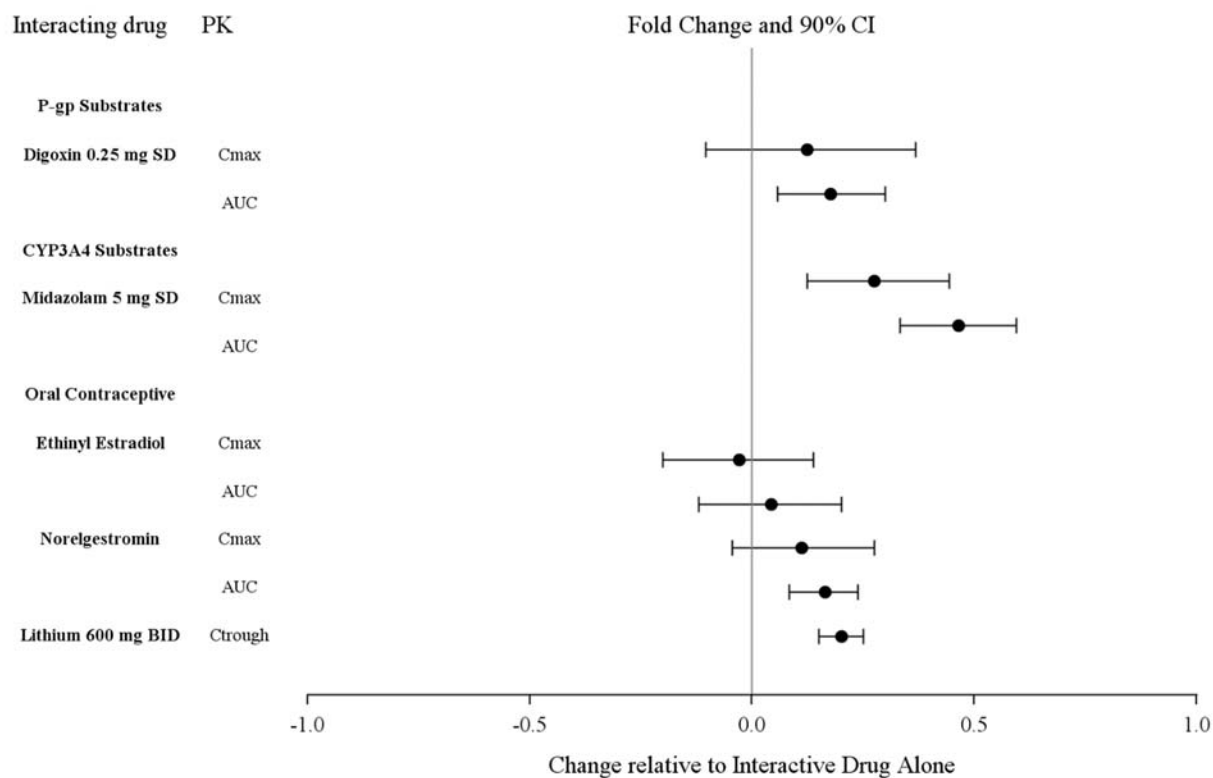

Figure 2: Impact of LATUDA on Other Drugs



Studies in Specific Populations

The effect of intrinsic patient factors on the pharmacokinetics of LATUDA is presented in [Figure 3](#).

Pediatric Patients

LATUDA exposure (i.e., steady-state Cmax and AUC) in children and adolescent patients (10 to 17 years of age) was generally similar to that in adults across the dose range from 40 to 160 mg, without adjusting for body weight.

Figure 3: Impact of Other Patient Factors on LATUDA Pharmacokinetics

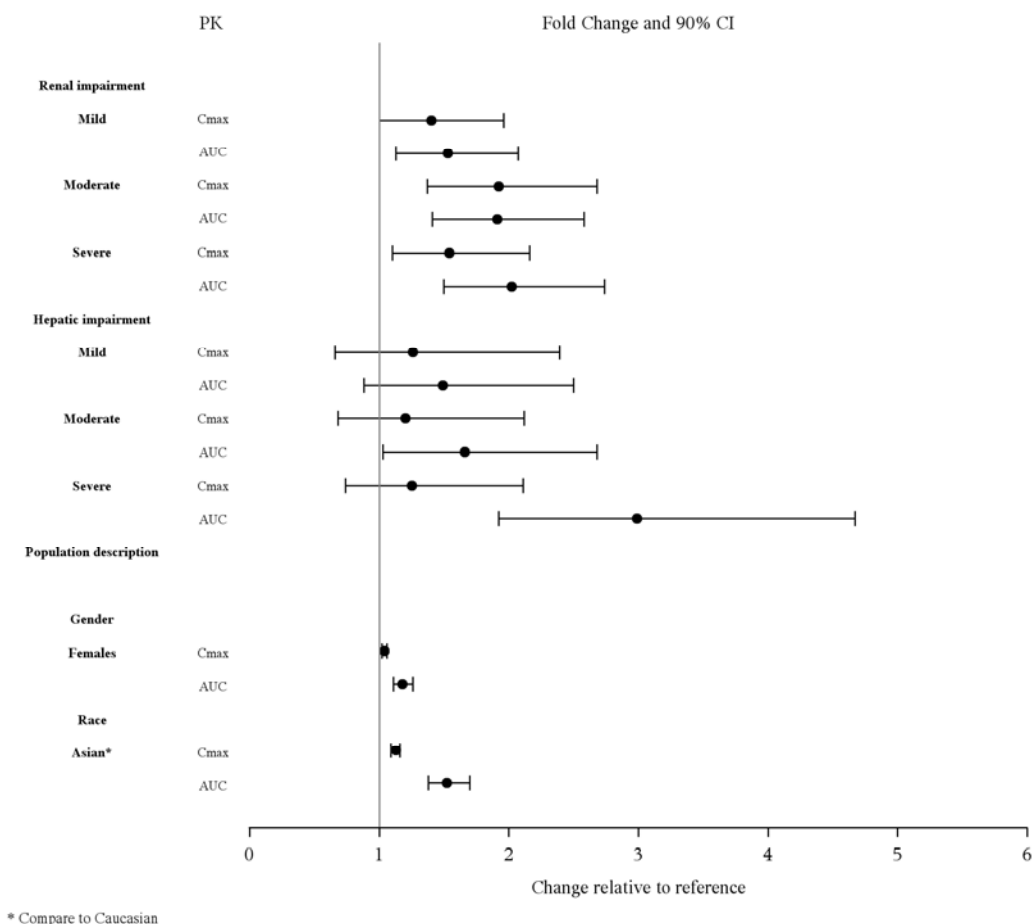

13 NONCLINICAL TOXICOLOGY

13.1 Carcinogenesis, Mutagenesis, Impairment of Fertility

Carcinogenesis: Lurasidone increased incidences of malignant mammary gland tumors and pituitary gland adenomas in female mice orally dosed with 30, 100, 300, or 650 mg/kg/day. The lowest dose produced plasma levels (AUC) approximately equal to those in humans receiving the MRHD of 160 mg/day. No increases in tumors were seen in male mice up to the highest dose tested, which produced plasma levels (AUC) 14 times those in humans receiving the MRHD.

Lurasidone increased the incidence of mammary gland carcinomas in female rats orally dosed at 12 and 36 mg/kg/day: the lowest dose; 3 mg/kg/day is the no-effect dose which produced plasma levels (AUC) 0.4 times those in humans receiving the MRHD. No increases in tumors were seen in male rats up to the highest dose tested, which produced plasma levels (AUC) 6 times those in humans receiving the MRHD.

Proliferative and/or neoplastic changes in the mammary and pituitary glands of rodents have been observed following chronic administration of antipsychotic drugs and are considered to be prolactin-mediated [see *Warnings and Precautions (5.7)*].

Mutagenesis: Lurasidone did not cause mutation or chromosomal aberration when tested *in vitro* and *in vivo test battery*. Lurasidone was negative in the Ames gene mutation test, the Chinese Hamster Lung (CHL) cells, and in the *in vivo* mouse bone marrow micronucleus test up to 2000 mg/kg which is 61 times the MRHD of 160 mg/day based on mg/m² body surface area.

Impairment of Fertility: Estrus cycle irregularities were seen in rats orally administered lurasidone at 1.5, 15 and 150 mg/kg/day for 15 consecutive days prior to mating, during the mating period, and through gestation day 7. No effect was seen at the lowest dose of 0.1 mg/kg which is approximately 0.006 times the MRHD of 160 mg/day based on mg/m². Fertility was reduced only at the highest dose, which was reversible after a 14 day drug-free period. The no-effect dose for reduced fertility was approximately equal to the MRHD based on mg/m².

Lurasidone had no effect on fertility in male rats treated orally for 64 consecutive days prior to mating and during the mating period at doses up to 9 times the MRHD based on mg/m².

14 CLINICAL STUDIES

14.1 Schizophrenia

Adults

The efficacy of LATUDA for the treatment of schizophrenia was established in five short-term (6-week), placebo-controlled studies in adult patients (mean age of 38.4 years, range 18-72) who met DSM-IV criteria for schizophrenia. An active-control arm (olanzapine or quetiapine extended-release) was included in two studies to assess assay sensitivity.

Several instruments were used for assessing psychiatric signs and symptoms in these studies:

1. Positive and Negative Syndrome Scale (PANSS), is a multi-item inventory of general psychopathology used to evaluate the effects of drug treatment in schizophrenia. PANSS total scores may range from 30 to 210.
2. Brief Psychiatric Rating Scale derived (BPRSd), derived from the PANSS, is a multi-item inventory primarily focusing on positive symptoms of schizophrenia, whereas the PANSS includes a wider range of positive, negative and other symptoms of schizophrenia. The BPRSd consists of 18 items rated on a scale of 1 (not present) to 7 (severe). BPRSd scores may range from 18 to 126.
3. The Clinical Global Impression severity scale (CGI-S) is a clinician-rated scale that measures the subject's current illness state on a 1- to 7-point scale.

The endpoint associated with each instrument is change from baseline in the total score to the end of week 6. These changes are then compared to placebo changes for the drug and control groups.

The results of the studies follow:

1. Study 1: In a 6-week, placebo-controlled trial (N=145) involving two fixed doses of LATUDA (40 or 120 mg/day), both doses of LATUDA at Endpoint were superior to placebo on the BPRSd total score, and the CGI-S.
2. Study 2: In a 6-week, placebo-controlled trial (N=180) involving a fixed dose of LATUDA (80 mg/day), LATUDA at Endpoint was superior to placebo on the BPRSd total score, and the CGI-S.
3. Study 3: In a 6-week, placebo- and active-controlled trial (N=473) involving two fixed doses of LATUDA (40 or 120 mg/day) and an active control (olanzapine), both LATUDA doses and the active control at Endpoint were superior to placebo on the PANSS total score, and the CGI-S.
4. Study 4: In a 6-week, placebo-controlled trial (N=489) involving three fixed doses of LATUDA (40, 80 or 120 mg/day), only the 80 mg/day dose of LATUDA at Endpoint was superior to placebo on the PANSS total score, and the CGI-S.
5. Study 5: In a 6-week, placebo- and active-controlled trial (N=482) involving two fixed doses of LATUDA (80 or 160 mg/day) and an active control (quetiapine extended-release), both LATUDA doses and the active control at Endpoint were superior to placebo on the PANSS total score, and the CGI-S.

Thus, the efficacy of LATUDA at doses of 40, 80, 120 and 160 mg/day has been established ([Table 35](#)).

Table 35: Primary Efficacy Results for Studies in Adult Patients with Schizophrenia (BPRSd or PANSS Scores)

Primary Efficacy Measure: BPRSd				
Study	Treatment Group	Mean Baseline Score (SD)	LS Mean Change from Baseline (SE)	Placebo-subtracted Difference^a (95% CI)
1	LATUDA (40 mg/day)*	54.2 (8.8)	-9.4 (1.6)	-5.6 (-9.8, -1.4)
	LATUDA (120 mg/day)*	52.7 (7.6)	-11.0 (1.6)	-6.7 (-11.0, -2.5)
	Placebo	54.7 (8.1)	-3.8 (1.6)	--
2	LATUDA (80 mg/day)*	55.1 (6.0)	-8.9 (1.3)	-4.7 (-8.3, -1.1)
	Placebo	56.1 (6.8)	-4.2 (1.4)	--
Primary Efficacy Measure: PANSS				
3	LATUDA (40 mg/day)*	96.6 (10.7)	-25.7 (2.0)	-9.7 (-15.3, -4.1)
	LATUDA (120 mg/day)*	97.9 (11.3)	-23.6 (2.1)	-7.5 (-13.4, -1.7)
	Olanzapine (15 mg/day)* ^b	96.3 (12.2)	-28.7 (1.9)	-12.6 (-18.2, -7.9)
	Placebo	95.8 (10.8)	-16.0 (2.1)	--
4	LATUDA (40 mg/day)	96.5 (11.5)	-19.2 (1.7)	-2.1 (-7.0, 2.8)
	LATUDA (80 mg/day)*	96.0 (10.8)	-23.4 (1.8)	-6.4 (-11.3, -1.5)
	LATUDA (120 mg/day)	96.0 (9.7)	-20.5 (1.8)	-3.5 (-8.4, 1.4)
	Placebo	96.8 (11.1)	-17.0 (1.8)	--
5	LATUDA (80 mg/day)*	97.7 (9.7)	-22.2 (1.8)	-11.9 (-16.9, -6.9)
	LATUDA (160 mg/day)*	97.5 (11.8)	-26.5 (1.8)	-16.2 (-21.2, -11.2)
	Quetiapine Extended-release (600 mg/day)* ^b	97.7 (10.2)	-27.8 (1.8)	-17.5 (-22.5, -12.4)
	Placebo	96.6 (10.2)	-10.3 (1.8)	--

SD: standard deviation; SE: standard error; LS Mean: least-squares mean; CI: confidence interval, unadjusted for multiple comparisons.

^a Difference (drug minus placebo) in least-squares mean change from baseline.

^b Included for assay sensitivity.

* Doses statistically significantly superior to placebo.

Examination of population subgroups based on age (there were few patients over 65), gender and race did not reveal any clear evidence of differential responsiveness.

Adolescents (13-17 years)

The efficacy of LATUDA, was established in a 6-week, multicenter, randomized, double-blind, placebo-controlled study of adolescents (13 to 17 years) who met DSM-IV-TR criteria for schizophrenia (N=326). Patients were randomized to one of two fixed-doses of LATUDA (40 or 80 mg/day) or placebo.

The primary rating instrument used to assess psychiatric signs and symptoms was the PANSS. The key secondary instrument was the CGI-S.

For both dose groups, LATUDA was superior to placebo in reduction of PANSS and CGI-S scores at Week 6. On average, the 80 mg/day dose did not provide additional benefit compared to the 40 mg/day dose.

The primary efficacy results are provided in [Table 36](#).

Table 36: Primary Efficacy Results (PANSS Total Score) for the Adolescent Schizophrenia Study

Treatment Group	Primary Efficacy Measure: PANSS		
	Mean Baseline Score (SD)	LS Mean Change from Baseline (SE)	Placebo-subtracted Difference ^a (95% CI)
LATUDA (40 mg/day)*	94.5 (10.97)	-18.6 (1.59)	-8.0 (-12.4, -3.7)
LATUDA (80 mg/day)*	94.0 (11.12)	-18.3 (1.60)	-7.7 (-12.1, -3.4)
Placebo	92.8 (11.08)	-10.5 (1.59)	--

SD: standard deviation; SE: standard error; LS Mean: least-squares mean; CI: confidence interval, unadjusted for multiple comparisons.

^a Difference (drug minus placebo) in least-squares mean change from baseline.

* Doses statistically significantly superior to placebo.

14.2 Depressive Episodes Associated with Bipolar I Disorder

Adults

Monotherapy

The efficacy of LATUDA, as monotherapy, was established in a 6-week, multicenter, randomized, double-blind, placebo-controlled study of adult patients (mean age of 41.5 years, range 18 to 74) who met DSM-IV-TR criteria for major depressive episodes associated with bipolar I disorder, with or without rapid cycling, and without psychotic features (N=485). Patients were randomized to one of two flexible-dose ranges of LATUDA (20 to 60 mg/day, or 80 to 120 mg/day) or placebo.

The primary rating instrument used to assess depressive symptoms in this study was the Montgomery-Asberg Depression Rating Scale (MADRS), a 10-item clinician-rated scale with total scores ranging from 0 (no depressive features) to 60 (maximum score). The primary endpoint was the change from baseline in MADRS score at Week 6. The key secondary instrument was the Clinical Global Impression-Bipolar-Severity of Illness scale (CGI-BP-S), a clinician-rated scale that measures the subject's current illness state on a 7-point scale, where a higher score is associated with greater illness severity.

For both dose groups, LATUDA was superior to placebo in reduction of MADRS and CGI-BP-S scores at Week 6. The primary efficacy results are provided in [Table 37](#). The high dose range (80

to 120 mg per day) did not provide additional efficacy on average, compared to the low dose range (20 to 60 mg per day).

Adjunctive Therapy with Lithium or Valproate

The efficacy of LATUDA, as an adjunctive therapy with lithium or valproate, was established in a 6-week, multicenter, randomized, double-blind, placebo-controlled study of adult patients (mean age of 41.7 years, range 18 to 72) who met DSM-IV-TR criteria for major depressive episodes associated with bipolar I disorder, with or without rapid cycling, and without psychotic features (N=340). Patients who remained symptomatic after treatment with lithium or valproate were randomized to flexibly dosed LATUDA 20 to 120 mg/day or placebo.

The primary rating instrument used to assess depressive symptoms in this study was the MADRS. The primary endpoint was the change from baseline in MADRS score at Week 6. The key secondary instrument was the CGI-BP-S scale.

LATUDA was superior to placebo in reduction of MADRS and CGI-BP-S scores at Week 6, as an adjunctive therapy with lithium or valproate (Table 37).

Table 37: Primary Efficacy Results for Adult Studies in Depressive Episodes Associated with Bipolar I Disorder (MADRS Scores)

Study	Treatment Group	Primary Efficacy Measure: MADRS		
		Mean Baseline Score (SD)	LS Mean Change from Baseline (SE)	Placebo-subtracted Difference ^a (95% CI)
Monotherapy study	LATUDA (20-60 mg/day)*	30.3 (5.0)	-15.4 (0.8)	-4.6 (-6.9, -2.3)
	LATUDA (80-120 mg/day)*	30.6 (4.9)	-15.4 (0.8)	-4.6 (-6.9, -2.3)
	Placebo	30.5 (5.0)	-10.7 (0.8)	--
Adjunctive Therapy study	LATUDA (20-120 mg/day)* + lithium or valproate	30.6 (5.3)	-17.1 (0.9)	-3.6 (-6.0, -1.1)
	Placebo + lithium or valproate	30.8 (4.8)	-13.5 (0.9)	--

SD: standard deviation; SE: standard error; LS Mean: least-squares mean; CI: confidence interval, unadjusted for multiple comparisons.

^a Difference (drug minus placebo) in least-squares mean change from baseline. * Treatment group statistically significantly superior to placebo.

Pediatric Patients (10 to 17 years)

The efficacy of LATUDA was established in a 6-week, multicenter, randomized, double-blind, placebo-controlled study of pediatric patients (10 to 17 years) who met DSM-5 criteria for a major depressive episode associated with bipolar I disorder, with or without rapid cycling, and without psychotic features (N=343). Patients were randomized to flexibly dosed LATUDA 20 to 80 mg/day or placebo. At the end of the clinical study, most patients (67%) received 20 mg/day or 40 mg/day.

The primary rating scale used to assess depressive symptoms in this study was the Children's Depression Rating Scale, Revised (CDRS-R) total score. The CDRS-R is a 17-item clinician-rated scale with total scores ranging from 17 to 113. The primary endpoint was the change from baseline in CDRS-R score at Week 6. The key secondary endpoint was the change from baseline in CGI-BP-S depression score.

LATUDA was superior to placebo in reduction of CDRS-R total score and CGI-BP-S depression score at Week 6. The primary efficacy results are provided in Table 38.

Table 38: Primary Efficacy Results for the Study in Depressive Episodes Associated with Bipolar I Disorder (CDRS-R Total Score) in Pediatric Patients (10 to 17 years)

Treatment Group	Primary Efficacy Measure: CDRS-R		
	Mean Baseline Score (SD)	LS Mean Change from Baseline (SE)	Placebo-subtracted Difference ^a (95% CI)
LATUDA (20 to 80 mg/day)*	59.2 (8.24)	-21.0 (1.06)	-5.7 (-8.4,-3.0)
Placebo	58.6 (8.26)	-15.3 (1.08)	--

SD: standard deviation; SE: standard error; LS Mean: least-squares mean; CI: confidence interval, unadjusted for multiple comparisons.

^a Difference (drug minus placebo) in least-squares mean change from baseline.

* Treatment group statistically significantly superior to placebo.

16 HOW SUPPLIED/STORAGE AND HANDLING

LATUDA tablets are white to off-white, round (20 mg or 40 mg), white to off-white, oblong (60 mg), pale green, oval (80 mg) or white to off-white, oval (120 mg) and identified with strength-specific one-sided debossing, “L20” (20 mg), “L40” (40 mg), “L80” (80 mg) or “L120” (120 mg). Tablets are supplied in the following strengths and package configurations (Table 39).

Table 39: Package Configuration for LATUDA Tablets

Tablet Strength	Package Configuration	NDC Code
20 mg	Bottles of 30	63402-302-30
	Bottles of 90	63402-302-90
	Bottles of 500	63402-302-50
	Box of 100 (Hospital Unit Dose) 10 blister cards, 10 tablets each	63402-302-10 Carton 63402-302-01 Blister
40 mg	Bottles of 30	63402-304-30
	Bottles of 90	63402-304-90
	Bottles of 500	63402-304-50
	Box of 100 (Hospital Unit Dose) 10 blister cards, 10 tablets each	63402-304-10 Carton 63402-304-01 Blister
60 mg	Bottles of 30	63402-306-30
	Bottles of 90	63402-306-90
	Bottles of 500	63402-306-50
	Box of 100 (Hospital Unit Dose) 10 blister cards, 10 tablets each	63402-306-10 Carton 63402-306-01 Blister
80 mg	Bottles of 30	63402-308-30
	Bottles of 90	63402-308-90
	Bottles of 500	63402-308-50
	Box of 100 (Hospital Unit Dose) 10 blister cards, 10 tablets each	63402-308-10 Carton 63402-308-01 Blister
120 mg	Bottles of 30	63402-312-30
	Bottles of 90	63402-312-90
	Bottles of 500	63402-312-50
	Box of 100 (Hospital Unit Dose) 10 blister cards, 10 tablets each	63402-312-10 Carton 63402-312-01 Blister

Storage

Store LATUDA tablets at 25°C (77°F); excursions permitted to 15° - 30°C (59° - 86°F) [*See USP Controlled Room Temperature*].

17 PATIENT COUNSELING INFORMATION

Advise the patient to read the FDA-approved patient labeling (Medication Guide).

Suicidal Thoughts and Behavior

Advise patients and caregivers to look for the emergence of suicidality, especially early during treatment and when the dosage is adjusted up or down and instruct them to report such symptoms to the healthcare provider [*see Boxed Warning, Warnings and Precautions (5.2)*].

Neuroleptic Malignant Syndrome

Counsel patients about a potentially fatal adverse reaction referred to as Neuroleptic Malignant Syndrome (NMS). Advise patients, family members, or caregivers to contact healthcare provider or to report to the emergency room if they experience signs and symptoms of NMS [*see Warnings and Precautions (5.4)*].

Tardive Dyskinesia

Counsel patients on the signs and symptoms of tardive dyskinesia and to contact their healthcare provider if these abnormal movements occur [*see Warnings and Precautions (5.5)*].

Metabolic Changes

Educate patients about the risk of metabolic changes, how to recognize symptoms of hyperglycemia and diabetes mellitus, and the need for specific monitoring, including blood glucose, lipids, and weight [*see Warnings and Precautions (5.6)*].

Hyperprolactinemia

Counsel patients on signs and symptoms of hyperprolactinemia that may be associated with chronic use of LATUDA. Advise them to seek medical attention if they experience any of the following: amenorrhea or galactorrhea in females, erectile dysfunction or gynecomastia in males [*see Warnings and Precautions (5.7)*].

Leukopenia/Neutropenia

Advise patients with a pre-existing low WBC or a history of drug-induced leukopenia/neutropenia that they should have their CBC monitored while taking LATUDA [*see Warnings and Precautions (5.8)*].

Orthostatic Hypotension

Educate patients about the risk of orthostatic hypotension, particularly at the time of initiating treatment, re-initiating treatment, or increasing the dose [*see Warnings and Precautions (5.9)*].

Interference with Cognitive and Motor Performance

Caution patients about performing activities requiring mental alertness, such as operating hazardous machinery or operating a motor vehicle, until they are reasonably certain that LATUDA therapy does not affect them adversely [*see Warnings and Precautions (5.12)*].

Heat Exposure and Dehydration

Educate patients regarding appropriate care in avoiding overheating and dehydration [*see Warnings and Precautions (5.13)*].

Activation of Mania or Hypomania

Advise patients and their caregivers to observe for signs of activation of mania/hypomania [*see Warnings and Precautions (5.14)*].

Concomitant Medication

Advise patients to inform their physicians if they are taking, or plan to take, any prescription or over-the-counter drugs, because there is a potential for drug interactions [*see Drug Interactions (7)*].

Pregnancy

Advise patients that LATUDA may cause extrapyramidal and/or withdrawal symptoms in a neonate. Advise patients to notify their healthcare provider with a known or suspected pregnancy [*see Use in Specific Populations (8.1)*]. Advise patients that there is a pregnancy exposure registry that monitors pregnancy outcomes in women exposed to LATUDA during pregnancy [*see Use in Specific Populations (8.1)*].



Manufactured for:
Sunovion Pharmaceuticals Inc.
Marlborough, MA 01752 USA

For Customer Service, call 1-888-394-7377.
For Medical Information, call 1-800-739-0565.
To report suspected adverse reactions, call 1-877-737-7226.

LATUDA is a registered trademark of Sumitomo Dainippon Pharma Co. Ltd.
Sunovion Pharmaceuticals Inc. is a U.S. subsidiary of Sumitomo Dainippon Pharma Co. Ltd.

© 2019 Sunovion Pharmaceuticals Inc.

MEDICATION GUIDE

LATUDA (luh-TOO-duh)

(lurasidone hydrochloride)

tablets

What is the most important information I should know about LATUDA?

LATUDA may cause serious side effects, including:

- **Increased risk of death in elderly people with dementia-related psychosis.** Medicines like LATUDA can raise the risk of death in elderly people who have lost touch with reality (psychosis) due to confusion and memory loss (dementia). LATUDA is not approved for the treatment of people with dementia-related psychosis.
- **Increased risk of suicidal thoughts or actions in children and young adults.** Antidepressant medicines may increase suicidal thoughts or actions in some children and young adults within the first few months of treatment and when the dose is changed.
- **Depression and other serious mental illnesses are the most important causes of suicidal thoughts and actions. Some people may have a particularly high risk of having suicidal thoughts or actions.** These include people who have (or have a family history of) depression, bipolar illness (also called manic-depressive illness), or a history of suicidal thoughts or actions.

How can I watch for and try to prevent suicidal thoughts and actions in myself or a family member?

- Pay close attention to any changes, especially sudden changes in mood, behaviors, thoughts, or feelings. This is very important when an antidepressant medicine is started or when the dose is changed.
- Call the healthcare provider right away to report new or sudden changes in mood, behavior, thoughts, or feelings.
- Keep all follow-up visits with the healthcare provider as scheduled. Call the healthcare provider between visits as needed, especially if you have concerns about symptoms.

Call a healthcare provider right away if you or your family member has any of the following symptoms, especially if they are new, worse, or worry you:

- | | |
|---|---|
| • thoughts about suicide or dying | • attempts to commit suicide |
| • new or worse depression | • new or worse anxiety |
| • feeling very agitated or restless | • panic attacks |
| • trouble sleeping (insomnia) | • new or worse irritability |
| • acting aggressive, being angry, or violent | • acting on dangerous impulses |
| • an extreme increase in activity and talking (mania) | • other unusual changes in behavior or mood |

What is LATUDA?

LATUDA is a prescription medicine used:

- To treat people 13 years of age or older with schizophrenia.
- Alone to treat people 10 years of age and older with depressive episodes that happen with Bipolar I Disorder (bipolar depression).
- With the medicine lithium or valproate to treat adults with depressive episodes that happen with Bipolar I Disorder (bipolar depression).

It is not known if LATUDA is safe and effective in children:

- less than 13 years of age with schizophrenia.

- less than 10 years of age with bipolar depression.
- for the treatment of irritability associated with autistic disorder.

Do not take LATUDA if you are:

- allergic to lurasidone hydrochloride or any of the ingredients in LATUDA. See the end of this Medication Guide for a complete list of ingredients in LATUDA.
- taking certain other medicines called CYP3A4 inhibitors or inducers including ketoconazole, clarithromycin, ritonavir, voriconazole, mibefradil, rifampin, avasimibe, St. John's wort, phenytoin, or carbamazepine. Ask your healthcare provider if you are not sure if you are taking any of these medicines.

Before taking LATUDA, tell your healthcare provider about all of your medical conditions, including if you:

- have or have had heart problems or stroke
- have or have had low or high blood pressure
- have or have had diabetes or high blood sugar, or have a family history of diabetes or high blood sugar.
- have or have had high levels of total cholesterol or triglycerides
- have or have had high prolactin levels
- have or have had low white blood cell count
- have or have had seizures
- have or have had kidney or liver problems
- are pregnant or plan to become pregnant. It is not known if LATUDA will harm your unborn baby. Talk to your healthcare provider about the risk to your unborn baby if you take LATUDA during pregnancy.
 - Tell your healthcare provider if you become pregnant or think you are pregnant during treatment with LATUDA.
 - If you become pregnant during treatment with LATUDA, talk to your healthcare provider about registering with the National Pregnancy Registry for Atypical Antipsychotics. You can register by calling 1-866-961-2388 or go to <http://womensmentalhealth.org/clinical-and-researchprograms/pregnancyregistry/>.
- are breastfeeding or plan to breastfeed. It is not known if LATUDA passes into your breast milk. Talk to your healthcare provider about the best way to feed your baby during treatment with LATUDA.

Tell your healthcare provider about all the medicines you take, including prescription and over-the-counter medicines, vitamins, and herbal supplements.

LATUDA and other medicines may affect each other causing possible serious side effects. LATUDA may affect the way other medicines work, and other medicines may affect how LATUDA works.

Your healthcare provider can tell you if it is safe to take LATUDA with your other medicines. Do not start or stop any other medicines during treatment with LATUDA without talking to your healthcare provider first.

Know the medicines you take. Keep a list of your medicines to show your healthcare provider and pharmacist when you get a new medicine.

How should I take LATUDA?

- Take LATUDA exactly as your healthcare provider tells you to take it. Do not change the dose or stop taking LATUDA without first talking to your healthcare provider.
- Take LATUDA by mouth, with food (at least 350 calories).
- If you take too much LATUDA, call your healthcare provider or poison control center or go to the nearest hospital emergency room right away.

What should I avoid while taking LATUDA?

- Do not drive, operate heavy machinery, or do other dangerous activities until you know how LATUDA affects you. LATUDA may make you drowsy.
- Avoid eating grapefruit or drinking grapefruit juice during treatment with LATUDA. Grapefruit and grapefruit juice may affect the amount of LATUDA in your blood.
- Do not become too hot or dehydrated during treatment with LATUDA.
 - Do not exercise too much.
 - In hot weather, stay inside in a cool place if possible.
 - Stay out of the sun.
 - Do not wear too much clothing or heavy clothing.
 - Drink plenty of water.

What are the possible side effects of LATUDA?

LATUDA may cause serious side effects, including:

- See “What is the most important information I should know about LATUDA?”
- **Stroke (cerebrovascular problems) in elderly people with dementia-related psychosis that can lead to death.**
- **Neuroleptic malignant syndrome (NMS) a serious condition that can lead to death.** Call your healthcare provider or go to the nearest hospital emergency room right away if you have some or all of the following signs and symptoms of NMS:
 - high fever
 - confusion
 - changes in your breathing, heart rate, and blood pressure
 - stiff muscles
 - increased sweating
- **Uncontrolled body movements (tardive dyskinesia).** LATUDA may cause movements that you cannot control in your face, tongue, or other body parts. Tardive dyskinesia may not go away, even if you stop taking LATUDA. Tardive dyskinesia may also start after you stop taking LATUDA.
- **Problems with your metabolism such as:**
 - **high blood sugar (hyperglycemia) and diabetes.** Increases in blood sugar can happen in some people who take LATUDA. Extremely high blood sugar can lead to coma or death. If you have diabetes or risk factors for diabetes (such as being overweight or a family history of diabetes), your healthcare provider should check your blood sugar before you start and during treatment with LATUDA.
Call your healthcare provider if you have any of these symptoms of high blood sugar during treatment with LATUDA:
 - feel very thirsty
 - feel very hungry
 - feel sick to your stomach
 - need to urinate more than usual
 - feel weak or tired
 - feel confused, or your breath smells fruity
 - **increased fat levels (cholesterol and triglycerides) in your blood.**
 - **weight gain.** You and your healthcare provider should check your weight regularly during treatment with LATUDA.
- **Increased prolactin levels in your blood (hyperprolactinemia).** Your healthcare provider may do blood tests to check your prolactin levels during treatment with LATUDA. Tell your healthcare provider if you have any of the following signs and symptoms of hyperprolactinemia:
Females:
 - absence of your menstrual cycle
 - secretion of breast milk when you are not breastfeeding

Males:

- problems getting or maintaining an erection (erectile dysfunction)
- enlargement of breasts (gynecomastia)

Low white blood cell count. Your healthcare provider may do blood tests during the first few months of treatment with LATUDA.

Decreased blood pressure (orthostatic hypotension). You may feel lightheaded or faint when you rise too quickly from a sitting or lying position.

Falls. LATUDA may make you sleepy or dizzy, may cause a decrease in your blood pressure when changing position (orthostatic hypotension), and can slow your thinking and motor skills which may lead to falls that can cause fractures or other injuries.

Seizures (convulsions)

- **Problems controlling your body temperature so that you feel too warm.** See “What should I avoid while taking LATUDA?”
- **Mania or hypomania** (manic episodes) in people with a history of bipolar disorder. Symptoms may include:
 - greatly increased energy
 - racing thoughts
 - unusually grand ideas
 - talking more or faster than usual
 - severe problems sleeping
 - reckless behavior
 - excessive happiness or irritability

Difficulty swallowing**The most common side effects of LATUDA include:**

- **Adults with schizophrenia:**
 - sleepiness or drowsiness
 - restlessness and feeling like you need to move around (akathisia)
 - difficulty moving, slow movements, muscle stiffness, or tremor
 - nausea
- **Children 13 to 17 years of age with schizophrenia:**
 - sleepiness or drowsiness
 - nausea
 - restlessness and feeling like you need to move around (akathisia)
 - difficulty moving, slow movements, muscle stiffness, or tremor
 - runny nose
 - vomiting
- **Adults with bipolar depression:**
 - restlessness and feeling like you need to move around (akathisia)
 - difficulty moving, slow movements, muscle stiffness, or tremor
 - sleepiness or drowsiness
- **Children 10 to 17 years of age with bipolar depression:**
 1. nausea
 2. weight gain
 3. problems sleeping (insomnia)

These are not all of the possible side effects of LATUDA.

Call your doctor for medical advice about side effects. You may report side effects to FDA at 1-800-FDA-1088.

How should I store LATUDA?

- Store LATUDA tablets at room temperature between 68°F to 77°F (20°C to 25°C).
- Keep LATUDA and all medicines out of the reach of children.

General information about the safe and effective use of LATUDA.

Medicines are sometimes prescribed for purposes other than those listed in a Medication Guide. Do not use LATUDA for a condition for which it was not prescribed. Do not give LATUDA to other people, even if they have the same symptoms that you have. It may harm them. You can ask your pharmacist or healthcare provider for information about LATUDA that is written for health professionals.

What are the ingredients in LATUDA?

Active ingredient: lurasidone hydrochloride

Inactive ingredients: mannitol, pregelatinized starch, croscarmellose sodium, hypromellose, magnesium stearate, Opadry® and carnauba wax. Additionally, the 80 mg tablet contains yellow ferric oxide and FD&C Blue No. 2 Aluminum Lake

Manufactured for: Sunovion Pharmaceuticals Inc. Marlborough, MA 01752 USA

LATUDA is a registered trademark of Sumitomo Dainippon Pharma Co. Ltd.; Sunovion Pharmaceuticals Inc. is a U.S. subsidiary of Dainippon Sumitomo Dainippon Pharma Co. Ltd. ©2019 Sunovion Pharmaceuticals Inc.

For more information, go to www.LATUDA.com or call 1-888-394-7377.

This Medication Guide has been approved by the U.S. Food and Drug Administration

Revised: 3/2018

PRODUCT MONOGRAPH
INCLUDING PATIENT MEDICATION INFORMATION

PrODEFSEY®

(emtricitabine/rilpivirine/tenofovir alafenamide) tablets

200 mg emtricitabine
25 mg rilpivirine (as rilpivirine hydrochloride)
25 mg tenofovir alafenamide (as tenofovir alafenamide hemifumarate)

Antiretroviral Agent

Gilead Sciences Canada, Inc.
Mississauga, ON L5N 2W3

www.gilead.ca

Submission Control No: 229507

Date of Initial Approval:
February 10, 2017

Date of Revision:
November 13, 2019

RECENT MAJOR LABEL CHANGES

Serious Warnings and Precautions Box (3)	06/2018
Dosage and Administration, Dosing Considerations (4.1)	10/2019
Dosage and Administration, Recommended Dose and Dose Adjustment (4.2)	12/2018
Warnings and Precautions, General (7)	10/2019
Warnings and Precautions, Cardiovascular (7)	10/2019
Warnings and Precautions, Serum Lipids and Blood Glucose (7)	06/2018
Warnings and Precautions, Gastrointestinal (7)	01/2018
Warnings and Precautions, Lactic Acidosis/Severe Hepatomegaly with Steatosis (7)	06/2018
Warnings and Precautions, Musculoskeletal (7)	06/2018
Warnings and Precautions, Renal (7)	10/2019
Warnings and Precautions, Risk of Adverse Reactions or Loss of Virologic Response Due to Drug Interactions (7)	10/2019
Warnings and Precautions, Special Populations, Pregnant Women (7.1.2)	12/2018

TABLE OF CONTENTS

RECENT MAJOR LABEL CHANGES.....	2
TABLE OF CONTENTS	2
PART I: HEALTH PROFESSIONAL INFORMATION.....	4
1. INDICATIONS	4
1.2 Geriatrics (≥ 65 years of age)	4
2. CONTRAINDICATIONS	5
3. SERIOUS WARNINGS AND PRECAUTIONS BOX.....	6
4. DOSAGE AND ADMINISTRATION	7
4.1. Dosing Considerations	7
4.2. Recommended Dose and Dose Adjustment	7
4.3. Missed Dose	8
5. OVERDOSAGE	9
6. DOSAGE FORMS, COMPOSITION AND PACKAGING	9
7. WARNINGS AND PRECAUTIONS.....	10
7.1. Special Populations	15
7.1.1. Patients Coinfected with HIV and HBV	15
7.1.2. Pregnant Women	16
7.1.3. Nursing Women.....	17
7.1.4. Pediatrics (< 18 years of age)	17
7.1.5. Geriatrics (≥ 65 years of age).....	18

8.	ADVERSE REACTIONS	18
8.1.	Adverse Drug Reaction Overview	18
8.2.	Clinical Trial Adverse Drug Reactions	18
	Clinical Trials in Virologically Suppressed Patients	20
	Clinical Trials in Adult Patients with Renal Impairment	21
	Patients coinfecting with Hepatitis B and/or Hepatitis C virus	21
8.3.	Less Common Clinical Trial Adverse Drug Reactions (< 1%)	21
8.4.	Abnormal Laboratory Findings: Hematologic, Clinical Chemistry and Other Quantitative Data	22
8.5.	Post-Market Adverse Drug Reactions	26
9.	DRUG INTERACTIONS	27
9.1.	Drug-Drug Interactions	27
9.2.	Drug-Food Interactions	38
9.3.	Drug-Herb Interactions	38
9.4.	Drug-Laboratory Interactions	38
10.	ACTION AND CLINICAL PHARMACOLOGY	38
10.1.	Mechanism of Action	38
10.2.	Pharmacodynamics	39
10.3.	Pharmacokinetics	40
11.	STORAGE, STABILITY AND DISPOSAL	46
12.	SPECIAL HANDLING INSTRUCTIONS	46
	PART II: SCIENTIFIC INFORMATION	47
13.	PHARMACEUTICAL INFORMATION	47
14.	CLINICAL TRIALS	49
14.1.	Study Demographics and Trial Design	52
14.2.	Study results	60
15.	MICROBIOLOGY	75
16.	NON-CLINICAL TOXICOLOGY	81
17.	SUPPORTING PRODUCT MONOGRAPHS	85
	PATIENT MEDICATION INFORMATION	86

PART I: HEALTH PROFESSIONAL INFORMATION

1. INDICATIONS

ODEFSEY (emtricitabine [FTC]/rilpivirine [RPV]/tenofovir alafenamide [TAF]) is indicated as a complete regimen for the treatment of adults infected with HIV-1 with no known mutations associated with resistance to the non-nucleoside reverse transcriptase inhibitor (NNRTI) class, tenofovir or FTC, and with a viral load \leq 100,000 copies/mL.

The safety and efficacy of ODEFSEY has not been established in patients with a prior history of virologic failure.

The following points should be considered prior to the initiation of therapy in patients with no antiretroviral treatment history:

- Regardless of HIV-1 RNA at the start of therapy, more RPV-treated patients with CD4+ cell count less than 200 cells/mm³ at the start of therapy experienced virologic failure compared to patients with CD4+ cell count greater than or equal to 200 cells/mm³.
- The observed virologic failure rate in RPV-treated patients conferred a higher rate of overall treatment resistance and cross-resistance to the NNRTI class compared to the control (efavirenz) (see **WARNINGS AND PRECAUTIONS, Resistance/Cross-resistance, MICROBIOLOGY, Resistance, Cross-resistance**).
- More patients treated with RPV developed tenofovir and lamivudine/FTC associated resistance compared to the control (see **WARNINGS AND PRECAUTIONS, Resistance/Cross-resistance, MICROBIOLOGY, Resistance, Cross-resistance**).

1.1 Pediatrics (< 18 years of age)

The safety and efficacy of ODEFSEY have not been established in pediatric patients.

1.2 Geriatrics (\geq 65 years of age)

ODEFSEY should be used with caution in patients \geq 65 years since clinical studies of the RPV component of ODEFSEY did not include sufficient numbers of these patients to determine whether they respond differently from adult patients < 65 years of age. No differences in safety or efficacy have been observed between elderly patients and those < 65 years of age receiving FTC+TAF (see **WARNINGS AND PRECAUTIONS, DOSAGE AND ADMINISTRATION and ACTION AND CLINICAL PHARMACOLOGY**).

2. CONTRAINDICATIONS

ODEFSEY is contraindicated in patients with known hypersensitivity to any of the components of the product. For a complete listing, see the **DOSAGE FORMS, COMPOSITION AND PACKAGING** section of the Product Monograph.

Coadministration of ODEFSEY is contraindicated with drugs which induce CYP3A enzymes or increase gastric pH as this may result in significant decreases in the plasma concentrations of RPV, a loss of virologic response and possible resistance to ODEFSEY or to the components of ODEFSEY. These drugs are listed in Table 1 (see **DRUG INTERACTIONS, Drug-Drug Interactions**).

Table 1. Drugs That Are Contraindicated with ODEFSEY

Drug Class	Drugs Within Class That Are Contraindicated with ODEFSEY	Clinical Comment
Anticonvulsant	carbamazepine, oxcarbazepine, phenobarbital, phenytoin	ODEFSEY is contraindicated with these anticonvulsants as coadministration may cause significant decreases in RPV and TAF plasma concentrations (induction of CYP3A and P-gp). This may result in loss of therapeutic effect of ODEFSEY and possible development of resistance to RPV and other NNRTIs.
Antimycobacterial	rifampin, rifapentine*	Concomitant use of ODEFSEY with rifampin, and rifapentine (induction of CYP3A and P-gp) may cause significant decreases in RPV and TAF plasma concentrations. This may result in loss of therapeutic effect of ODEFSEY. Coadministration of ODEFSEY with rifampin and rifapentine is contraindicated.
Glucocorticoid	systemic dexamethasone (more than a single dose)	ODEFSEY is contraindicated in combination with systemic dexamethasone as coadministration may cause significant decreases in RPV plasma concentrations (induction of CYP3A enzymes). This may result in loss of therapeutic effect of ODEFSEY and possible development of resistance to RPV and other NNRTIs. Alternatives should be considered, particularly for long-term use.
Herbal product	St. John's wort (<i>Hypericum perforatum</i>)	ODEFSEY is contraindicated with products containing St. John's wort as coadministration may cause significant

Drug Class	Drugs Within Class That Are Contraindicated with ODEFSEY	Clinical Comment
		decreases in RPV and TAF plasma concentrations (induction of CYP3A). This may result in loss of therapeutic effect of ODEFSEY and possible development of resistance to RPV and other NNRTIs.
Proton pump inhibitor	omeprazole, esomeprazole, lansoprazole, dexlansoprazole, pantoprazole, rabeprazole	ODEFSEY is contraindicated with proton pump inhibitors as coadministration may cause significant decreases in RPV plasma concentrations (increase in gastric pH). This may result in loss of therapeutic effect of ODEFSEY and possible development of resistance to RPV and other NNRTIs.

*Drug not marketed in Canada

3. SERIOUS WARNINGS AND PRECAUTIONS BOX

<u>Serious Warnings and Precautions</u>
<ul style="list-style-type: none"> <li data-bbox="207 1081 992 1115">● Post-treatment Exacerbation of Hepatitis B Virus <p data-bbox="207 1150 1385 1549">ODEFSEY is not approved for the treatment of chronic hepatitis B virus (HBV) and the safety and efficacy of ODEFSEY have not been established in patients coinfecting with HIV-1 and HBV. Discontinuation of ODEFSEY therapy in patients coinfecting with HIV-1 and HBV may be associated with severe acute exacerbations of hepatitis due to the FTC or TAF components of ODEFSEY. Patients coinfecting with HIV-1 and HBV who discontinue ODEFSEY should be closely monitored with both clinical and laboratory follow-up for at least several months after stopping treatment. If appropriate, initiation of anti-hepatitis B therapy may be warranted, especially in patients with advanced liver disease or cirrhosis since post-treatment exacerbation of hepatitis may lead to hepatic decompensation (See WARNINGS AND PRECAUTIONS, <u>Special Populations</u>).</p>

4. DOSAGE AND ADMINISTRATION

4.1. Dosing Considerations

Do not take other products containing any of the same active components (see **WARNINGS AND PRECAUTIONS, General**).

Testing Prior to Initiation and During Treatment with ODEFSEY

Viral load must be determined prior to initiation of therapy. Therapy must not be initiated in patients with a viral load $\geq 100\,000$ copies/mL.

Prior to or when initiating ODEFSEY, test patients for hepatitis B virus infection.

Prior to or when initiating ODEFSEY, and during treatment with ODEFSEY, on a clinically appropriate schedule, assess serum creatinine, estimated creatinine clearance, urine glucose, and urine protein in all patients. In patients with chronic kidney disease, also assess serum phosphorus.

4.2. Recommended Dose and Dose Adjustment

Adults

The recommended dose of ODEFSEY is one tablet of 200 mg/25 mg/25 mg FTC/RPV/TAF, taken orally once daily. ODEFSEY must be taken **with a meal to obtain optimal absorption of RPV** (see **ACTION AND CLINICAL PHARMACOLOGY, Pharmacokinetics**).

Pediatrics (< 18 years of age)

ODEFSEY is not indicated for use in pediatric patients <18 years of age.

Geriatrics (≥ 65 years of age)

No data are available on which to make a dose recommendation for patients ≥ 65 years of age. In clinical trials, 80 of the 97 patients enrolled aged 65 years and over received FTC+TAF given with EVG+COBI as a FDC tablet (administered as GENVOYA). No differences in safety or efficacy have been observed between elderly patients and those < 65 years of age. Clinical trials of RPV did not include sufficient numbers of patients aged ≥ 65 to determine whether they respond differently from younger patients (see **ACTION AND CLINICAL PHARMACOLOGY**).

Pregnant Women

Lower exposures of RPV were observed during pregnancy; therefore, viral load should be monitored closely (see **WARNINGS AND PRECAUTIONS** and **ACTION AND CLINICAL PHARMACOLOGY**).

Renal Impairment

No dose adjustment of ODEFSEY is required in adult patients with estimated creatinine clearance ≥ 30 mL/minute. ODEFSEY should not be initiated in patients with estimated creatinine clearance < 30 mL/minute as there are insufficient data available regarding the use of ODEFSEY in this population. No dose adjustment of RPV is required in patients with mild or moderate renal impairment (see **ACTION AND CLINICAL PHARMACOLOGY**). For additional information, consult the EDURANT Product Monograph.

The safety, virologic, and immunologic responses for FTC+TAF components of ODEFSEY are based on an open-label trial (Study 112) that evaluated FTC+TAF given with EVG+COBI as a FDC tablet (administered as GENVOYA) in adult patients with mild to moderate renal impairment (eGFR by Cockcroft-Gault method 30–69 mL/min). The safety profile of FTC+TAF in patients with mild to moderate renal impairment was similar to those with normal renal function. For additional information, consult the GENVOYA Product Monograph.

Hepatic Impairment

No dose adjustment of ODEFSEY is required in patients with mild (Child-Pugh Class A) or moderate (Child-Pugh Class B) hepatic impairment. The RPV component of ODEFSEY has not been studied in patients with severe hepatic impairment (Child-Pugh Class C); therefore, ODEFSEY is not recommended for use in patients with severe hepatic impairment (see **ACTION AND CLINICAL PHARMACOLOGY**).

4.3. Missed Dose

If a patient misses a dose of ODEFSEY within 12 hours of the time it is usually taken, the patient should take ODEFSEY with a meal as soon as possible, and then take the next dose of ODEFSEY at the regularly scheduled time.

If a patient misses a dose of ODEFSEY by more than 12 hours, the patient should not take the missed dose, but resume the usual dosing schedule.

If the patient vomits within 4 hours of taking ODEFSEY, another tablet should be taken with a meal. If a patient vomits more than 4 hours after taking ODEFSEY, they do not need to take another dose of ODEFSEY until the next regularly scheduled dose.

5. OVERDOSAGE

For management of a suspected drug overdose, contact your regional Poison Control Centre.

If overdose occurs the patient must be monitored for evidence of toxicity. Treatment of overdose with ODEFSEY consists of general supportive measures including monitoring of vital signs and ECG (QT interval) as well as observation of the clinical status of the patient.

Emtricitabine

Limited clinical experience is available at doses higher than the therapeutic dose of FTC. In one clinical pharmacology study, single doses of FTC 1200 mg (6 times the dose in ODEFSEY) were administered to 11 subjects. No severe adverse reactions were reported. The effects of higher doses are not known.

Emtricitabine can be removed by hemodialysis, which removes approximately 30% of the FTC dose over a 3-hour dialysis period starting within 1.5 hours of FTC dosing.

It is not known whether FTC can be removed by peritoneal dialysis.

Rilpivirine

There is no specific antidote for overdose with RPV. Human experience of overdose with RPV is limited. Since RPV is highly bound to plasma protein, dialysis is unlikely to result in significant removal of RPV.

Tenofovir alafenamide

Limited clinical experience is available at doses higher than the therapeutic dose of TAF. A single supratherapeutic dose of 125 mg TAF was administered to 48 healthy subjects. No serious adverse reactions were reported. The effects of higher doses are unknown. Tenofovir is efficiently removed by hemodialysis with an extraction coefficient of approximately 54%.

6. DOSAGE FORMS, COMPOSITION AND PACKAGING

ODEFSEY is available as tablets. Each tablet contains 200 mg of FTC, 25 mg of RPV (as 27.5 mg of RPV hydrochloride) and 25 mg of TAF (as 28.0 mg of TAF hemifumarate).

The tablets also include the following inactive ingredients: croscarmellose sodium, lactose monohydrate, magnesium stearate, microcrystalline cellulose, polysorbate 20 and povidone. The tablets are coated with a coating material containing polyvinyl alcohol, titanium dioxide, macrogol/polyethylene glycol, talc, and iron oxide black.

ODEFSEY tablets are gray, capsule-shaped, film-coated, debossed with 'GSI' on one side of the tablet and '255' on the other side of the tablet. Each bottle contains 30 tablets, a silica gel desiccant, polyester coil and is closed with a child-resistant closure.

7. WARNINGS AND PRECAUTIONS

Please see the **SERIOUS WARNINGS AND PRECAUTIONS BOX** at the beginning of Part I: Health Professional Information.

General

As ODEFSEY is a fixed-dose combination (FDC) of FTC, RPV and TAF, it should not be administered concurrently with products containing any of the same active components, (ATRIPLA[®], BIKTARVY[®], COMPLERA[®], DESCOVY[®], Edurant[®], EMTRIVA[®], STRIBILD[®], Symtuza[™], TRUVADA[®], GENVOYA[®], VEMLIDY[®]); or with products containing lamivudine or tenofovir disoproxil fumarate (3TC[®], ATRIPLA, Combivir[®], COMPLERA, Kivexa[®], STRIBILD, Triumeq[®], Trizivir[®], TRUVADA, VIREAD[®]) or with adefovir dipivoxil (HEPSERA[®]).

Caution should be given to prescribing ODEFSEY with medicinal products that may reduce the exposure of RPV (see **CONTRAINDICATIONS** and

DRUG INTERACTIONS, Drug-Drug Interactions).

As with other antiretroviral medicinal products, resistance testing should guide the use of ODEFSEY.

Carcinogenesis and Mutagenesis

Rilpivirine induced benign and malignant tumors in the liver of mice and rats. These tumors are caused by the enzyme induction that RPV caused in these species which may be rodent-specific. In rats, RPV caused benign and malignant tumors of the thyroid follicular cells. These tumors are the result of continuous stimulation of the follicular cells due to the increased clearance of thyroxine caused by RPV in this species. This effect is considered rat-specific.

Cardiovascular

ODEFSEY should be administered with caution to patients who are suspected to be at an increased risk of experiencing proarrhythmic conditions such as hypokalemia, clinically significant bradycardia, acute myocardial ischemia, congestive heart failure or congenital prolongation of QTc interval (see **ADVERSE REACTIONS,**

DRUG INTERACTIONS and **ACTION AND CLINICAL PHARMACOLOGY**).

In healthy subjects, RPV has been associated with prolongation of the QT interval of the electrocardiogram at doses of 75 mg and 300 mg once daily. In antiretroviral-naïve, HIV-1 infected patients receiving RPV 25 mg once daily in Phase III clinical trials, which excluded patients with high risk factors for proarrhythmia, the mean QTc interval increased gradually over 48 weeks and remained stable through Week 96. An increase of > 60 ms in QTcF interval resulting in abnormal values of > 480 ms was reported in one patient. Prolongation of QT interval may increase the risk of cardiac arrhythmias.

There is limited information available on the potential for a pharmacodynamic interaction between RPV and drugs that prolong the QTc interval of the electrocardiogram.

ODEFSEY should be used with caution when co-administered with drugs with a known risk of Torsade de Pointes.

Depressive Disorders

During the Phase III trials of RPV in adult patients (N = 686) through 96 weeks, the incidence of depressive disorder adverse drug reactions (depressed mood, depression, dysphoria, major depression, mood altered, negative thoughts, suicide attempt, suicidal ideation) of at least moderate intensity (Grades 2 to 4) was 5%. The incidence of discontinuation due to depressive disorders was 1%. Suicide attempt was reported in 2 patients while suicide ideation was reported in 4 patients taking RPV. The incidence of these events was similar in the control group.

Patients with severe depressive symptoms should seek immediate medical evaluation to assess the possibility that the symptoms are related to RPV, and if so, to determine whether the risks of continued therapy with ODEFSEY outweigh the benefits.

Endocrine and Metabolism

Serum Lipids and Blood Glucose

Serum lipid and blood glucose levels may increase during antiretroviral therapy. Disease control and life style changes may also be contributing factors. Consideration should be given to the measurement of serum lipids and blood glucose. Lipid disorders and blood glucose elevations should be managed as clinically appropriate.

Gastrointestinal

ODEFSEY contains lactose. This medicine is not recommended for patients with rare hereditary problems of galactose intolerance (severe lactase deficiency or glucose-galactose malabsorption).

Hepatic/Biliary/Pancreatic

Hepatic Impairment

Emtricitabine has not been evaluated in patients with hepatic impairment; however, emtricitabine is not significantly metabolized by liver enzymes, so the impact of liver impairment is likely to be limited.

Rilpivirine is primarily metabolized and eliminated by the liver. No dose adjustment of ODEFSEY is required in patients with mild (Child-Pugh Class A) or moderate (Child-Pugh Class B) hepatic impairment. Rilpivirine has not been studied in patients with severe hepatic impairment (Child-Pugh Class C) and the use of ODEFSEY is not recommended in this population. Given that the metabolism of RPV is cytochrome P450-mediated and that clinical experience in patients with mild or moderate hepatic impairment is limited, caution should be exercised when administering ODEFSEY to this population (see **ACTION AND CLINICAL PHARMACOLOGY**).

Clinically relevant changes in tenofovir pharmacokinetics were not observed in patients with mild, moderate, or severe hepatic impairment, and no TAF dose adjustment is required in patients with hepatic impairment.

The safety and efficacy of ODEFSEY have not been studied specifically in patients with underlying liver disorders. Patients with chronic hepatitis B or C who are treated with antiretroviral therapy are at increased risk for severe and potentially fatal hepatic adverse events (see **WARNINGS AND PRECAUTIONS, Special Populations**).

Hepatotoxicity

Hepatic adverse events have been reported in patients receiving an RPV-containing regimen. Patients with underlying hepatitis B or C, or marked elevations in transaminases prior to treatment, may be at increased risk for worsening or development of transaminase elevations with use of RPV. A few cases of hepatic toxicity have been reported in adult patients receiving a RPV-containing regimen who had no pre-existing hepatic disease or other identifiable risk factors. Appropriate laboratory testing prior to initiating therapy and monitoring for hepatotoxicity during therapy with RPV is recommended in patients with underlying hepatic disease such as hepatitis B or C, or in patients with marked elevations in transaminases prior to treatment initiation. Liver enzyme monitoring should also be considered for patients without pre-existing hepatic dysfunction or other risk factors.

Pancreatitis

Caution should be exercised in the use of ODEFSEY in patients with a history of pancreatitis or risk factors for the development of pancreatitis. Pancreatitis has occurred during the use of nucleoside analogues. Therapy should be suspended in patients with suspected pancreatitis.

Lactic Acidosis/Severe Hepatomegaly with Steatosis

Lactic acidosis and severe hepatomegaly with steatosis, including fatal cases, have been reported with the use of nucleoside analogs, including FTC, a component of ODEFSEY, and tenofovir disoproxil fumarate (TDF), another prodrug of tenofovir, alone or in combination with other antiretrovirals. Treatment with ODEFSEY should be suspended in any patient who develops clinical or laboratory findings suggestive of lactic acidosis or pronounced hepatotoxicity (which may include hepatomegaly and steatosis even in the absence of marked transaminase elevations).

Immune

Immune Reconstitution Inflammatory Syndrome

Immune reconstitution inflammatory syndrome has been reported in patients treated with combination ART, including RPV, FTC, and ODEFSEY. During the initial phase of combination antiretroviral treatment, patients responding to ART may develop an inflammatory response to indolent or residual opportunistic infections (such as *Mycobacterium avium*-complex [MAC], cytomegalovirus [CMV], *Pneumocystis jirovecii* pneumonia [PCP], or tuberculosis [TB]), which may necessitate further evaluation and treatment.

Autoimmune disorders (such as Graves' disease, polymyositis, Guillain-Barré syndrome, and autoimmune hepatitis) have also been reported to occur in the setting of immune reconstitution, however, the time to onset is more variable, and can occur many months after initiation of treatment.

Musculoskeletal

Bone Effects

Tenofovir alafenamide and tenofovir have been shown to be associated with decreases in bone mineral density (BMD) in animal toxicology studies and in human clinical trials.

In a pooled analysis of two Phase III clinical studies in HIV-1 infected ART treatment-naïve adults who received FTC+TAF given with EVG+COBI as a FDC (administered as GENVOYA), the percentage of patients who had more than a 3% decrease from baseline in hip and spine BMD at Week 48 was 17% and 27%, respectively, at Week 96 was 23% and 26%, respectively, and at Week 144 was 28% and 30%, respectively (see **CLINICAL TRIALS**).

The effects of TAF-associated changes in BMD and biochemical markers on long-term bone health and future fracture risk are unknown.

Renal

Rilpivirine (a component of ODEFSEY) has not been studied in patients with renal impairment. Caution should be exercised prior to prescribing ODEFSEY to patients with severe renal impairment or end-stage renal disease whose drug absorption, distribution and metabolism may be altered secondary to renal dysfunction (see **Dosing Considerations, Testing Prior to Initiation and During Treatment with ODEFSEY**).

Renal impairment, including cases of acute renal failure and Fanconi syndrome (renal tubular injury with severe hypophosphatemia), has been reported with the use of tenofovir prodrugs in both animal toxicology studies and human trials. In clinical trials of FTC+TAF given with EVG+COBI as a FDC (administered as GENVOYA), there have been no cases of Fanconi syndrome or proximal renal tubulopathy.

Patients taking tenofovir prodrugs who have impaired renal function and those taking nephrotoxic agents including non-steroidal anti-inflammatory drugs are at increased risk of developing renal-related adverse reactions.

ODEFSEY should not be initiated in patients with estimated creatinine clearance below 30 mL / minute as there are insufficient data available regarding the use of ODEFSEY in this population.

Prior to or when initiating ODEFSEY, and during treatment with ODEFSEY, on a clinically appropriate schedule, assess serum creatinine, estimated creatinine clearance, urine glucose, and urine protein in all patients. In patients with chronic kidney disease, also assess serum phosphorus. Discontinue ODEFSEY in patients who develop clinically significant decreases in renal function or evidence of Fanconi syndrome.

Resistance/Cross-resistance

In the pooled analysis from two Phase III trials conducted with RPV, the emergence of resistance among patients was greater in the RPV arm as compared to the control (efavirenz) arm at Week 48 (10.6%, 5.3%, respectively) and at Week 96 (14%, 7.6%, respectively). More RPV-treated patients with baseline HIV-1 RNA > 100,000 copies/mL experienced virologic failure compared to patients with HIV RNA ≤ 100,000 copies/mL at baseline.

The observed virologic failures in RPV-treated patients conferred a higher cross resistance to the NNRTI class as compared to those in control-treated patients. More patients treated with RPV developed lamivudine/emtricitabine associated resistance as compared to those treated with the comparator (see **MICROBIOLOGY, Resistance, Cross-resistance**).

Risk of Adverse Reactions or Loss of Virologic Response Due to Drug Interactions

The concomitant use of ODEFSEY and other drugs may result in potentially significant drug interactions, some of which may lead to the loss of therapeutic effect of ODEFSEY and possible development of resistance due to reduced exposure of RPV (see **CONTRAINDICATIONS** and **DRUG INTERACTIONS**). Consider the potential for drug interactions prior to and during ODEFSEY therapy and review concomitant medications during ODEFSEY therapy.

Skin and Hypersensitivity Reactions

Severe skin and hypersensitivity reactions have been reported during the post-marketing experience, including cases of Drug Reaction with Eosinophilia and Systemic Symptoms (DRESS), with RPV-containing regimens. While some skin reactions were accompanied by constitutional symptoms such as fever, other skin reactions were associated with organ dysfunctions, including elevations in hepatic serum biochemistries. During the Phase III clinical trials conducted with RPV, treatment-related rashes with at least Grade 2 severity were reported in 3% of patients receiving RPV. No grade 4 rash was reported. Overall, most rashes were Grade 1 or 2 and occurred in the first four to six weeks of therapy (see **ADVERSE REACTIONS**). Discontinue ODEFSEY immediately if signs or symptoms of severe skin or hypersensitivity reactions develop, including but not limited to, severe rash or rash accompanied by fever, blisters, mucosal involvement, conjunctivitis, facial edema, angioedema, hepatitis or eosinophilia. Clinical status including laboratory parameters should be monitored and appropriate therapy should be initiated.

7.1. Special Populations

7.1.1. Patients Coinfected with HIV and HBV

The safety and efficacy of ODEFSEY have not been established in patients coinfecting with HIV-1 and HBV. It is recommended that all patients with HIV-1 be tested for HBV before or when initiating ART.

Severe acute exacerbations of hepatitis B (and association with liver decompensation and liver failure in some patients) may occur in patients coinfecting with HIV-1 and HBV after discontinuation of FTC and TAF, two of the components of ODEFSEY.

Hepatic function should be closely monitored with both clinical and laboratory follow-up for at least several months in patients who discontinue ODEFSEY and are coinfecting with HIV-1 and HBV. If appropriate, initiation of anti-hepatitis B therapy may be warranted. In patients with advanced liver disease or cirrhosis, post-treatment exacerbation of hepatitis may lead to hepatic decompensation and liver failure. In these

patients, therefore, discontinuation of treatment without initiation of alternative anti-hepatitis B therapy is not recommended.

7.1.2. Pregnant Women

There are no adequate and well-controlled studies of ODEFSEY or its components in pregnant women. ODEFSEY should not be used during pregnancy-unless the potential benefits outweigh the potential risks to the fetus.

Lower exposures of RPV were observed during pregnancy; therefore, viral load should be monitored closely.

Emtricitabine

The incidence of fetal variations and malformations was not increased in embryo-fetal toxicity studies performed with FTC in mice at exposures (AUC) approximately 60 times higher and in rabbits at approximately 120 times higher than human exposures at the recommended daily dose.

Rilpivirine

Rilpivirine in combination with a background regimen was evaluated in a clinical trial of 19 pregnant women during the second and third trimesters, and postpartum. The pharmacokinetic data demonstrate that total exposure (AUC) to RPV as a part of an antiretroviral regimen was approximately 30% lower during pregnancy compared with postpartum (6–12 weeks). Virologic response was preserved throughout the trial period. No mother to child transmission occurred in all 10 infants born to the mothers who completed the trial and for whom the HIV status was available. Rilpivirine was well tolerated during pregnancy and postpartum. There were no new safety findings compared with the known safety profile of RPV in HIV-1 infected adults (see **ACTION AND CLINICAL PHARMACOLOGY, Special Populations and Conditions, Pregnancy and Postpartum**).

Studies in animals have shown no evidence of embryonic or fetal toxicity or an effect on reproductive function. There was no teratogenicity with RPV in rats and rabbits. The exposures at the embryo-fetal No Observed Adverse Effects Levels (NOAEL) in rats and rabbits were respectively 15 and 70 times higher than the exposure in humans at the recommended dose of 25 mg once daily.

Tenofovir Alafenamide

In the embryo-fetal development study in rats, administration of TAF was associated with reduced fetal body weight and delayed ossification rate at ≥ 100 mg/kg. The NOAEL for embryo-fetal development was 25 mg/kg (approximately 10 times the clinical tenofovir exposure based on AUC).

In the embryo-fetal toxicity study in pregnant rabbits, administration of TAF resulted in significantly increased number of litters with minor external and visceral anomalies at 100 mg/kg (approximately 90 times the clinical tenofovir exposure based on AUC). The NOAEL for embryo-fetal development was 30 mg/kg/day (approximately 17 times the clinical tenofovir exposure based on AUC).

In the peri- and postnatal development study, administration of TDF, another prodrug of tenofovir, to pregnant rats resulted in increased peri/postpartum pup mortality, reduced pup survival, reduced pup body weights, reduced survival of F1 generation, reduced body weight/food consumption of F1 generation, and delayed sexual maturation of F1 generation at ≥ 400 mg/kg (approximately 90 times the clinical tenofovir exposure based on AUC). The NOAEL for these effects was 150 mg/kg (approximately 25 times the clinical tenofovir exposure based on AUC). These results are considered relevant to TAF.

Antiretroviral Pregnancy Registry: To monitor fetal outcomes of pregnant women exposed to ART including ODEFSEY, an Antiretroviral Pregnancy Registry has been established. Healthcare providers are encouraged to register patients,

<http://www.apregistry.com>
Telephone: 1 - (800) 258-4263
Fax: 1 - (800) 800-1052

7.1.3. Nursing Women

HIV-1 infected mothers should not breastfeed their infants to avoid risking postnatal transmission of HIV.

In humans, samples of breast milk obtained from five HIV-1 infected mothers given TRUVADA (FTC/TDF) show that FTC is secreted in human milk at estimated neonatal concentrations 3 to 12 times higher than the FTC IC_{50} but 3 to 12 times lower than the C_{min} achieved from oral administration of FTC. Breastfeeding infants whose mothers are being treated with FTC may be at risk for developing viral resistance to FTC. Other FTC-associated risks in infants breastfed by mothers being treated with FTC are unknown.

In animal studies it has been shown that tenofovir is secreted into milk. It is not known whether RPV and TAF are secreted in human milk.

Because of both the potential for HIV transmission and the potential for serious adverse reactions in nursing infants, **mothers should be instructed not to breastfeed if they are receiving ODEFSEY.**

7.1.4. Pediatrics (< 18 years of age)

The safety and efficacy of ODEFSEY have not been established in pediatric patients.

7.1.5. Geriatrics (≥ 65 years of age)

No data are available on which to make a dose recommendation for patients over the age of 65 years. In clinical trials, 80 of the 97 patients enrolled aged 65 years and over received FTC+TAF given with EVG+COBI as a FDC (administered as GENVOYA). No differences in safety or efficacy have been observed between elderly patients and those < 65 years of age (see **ACTION AND CLINICAL PHARMACOLOGY**). Clinical studies of RPV did not include sufficient numbers of patients aged 65 and over to determine whether they respond differently from adult patients < 65 years of age. In general, dose selection for the elderly patient should be cautious, keeping in mind the greater frequency of decreased hepatic, renal, or cardiac function, and of concomitant disease or other drug therapy.

8. ADVERSE REACTIONS

8.1. Adverse Drug Reaction Overview

No data are available from clinical studies of ODEFSEY in HIV-1 infected patients. The safety of ODEFSEY is based on studies of FTC+TAF when given with EVG+COBI as the FDC tablet, GENVOYA, and studies of RPV when given with FTC+TDF as individual components or as the FDC tablet, COMPLERA (FTC/RPV/TDF).

8.2. Clinical Trial Adverse Drug Reactions

Because clinical trials are conducted under very specific conditions the adverse reaction rates observed in the clinical trials may not reflect the rates observed in practice and should not be compared to the rates in the clinical trials of another drug. Adverse drug reaction information from clinical trials is useful for identifying drug-related adverse events and for approximating rates.

Clinical Trials in Treatment-Naïve Adults

Emtricitabine+Tenofovir Alafenamide-Containing Regimens

The safety assessment of FTC and TAF is based on Weeks 48, 96, and 144 pooled data from 1733 patients in two comparative clinical trials, Study GS-US-292-0104 (Study 104) and Study GS-US-292-0111 (Study 111), in antiretroviral treatment-naïve HIV-1 infected adult patients who received FTC+TAF (N = 866) given with EVG+COBI as a FDC tablet (administered as GENVOYA) once daily.

The proportion of patients who discontinued treatment with FTC+TAF (administered as GENVOYA) or FTC+TDF (administered as STRIBILD) due to adverse events, regardless of severity, was 0.9% and 1.5% at Week 48, and 1.3% and 3.3% at Week 144, respectively. Table 2 displays the frequency of adverse reactions (Grades 2-4) ≥ 1% observed in patients receiving FTC + TAF (administered as GENVOYA).

Table 2. Adverse Reactions^a (Grades 2-4) Reported in ≥ 1% of HIV-1 Infected Treatment-Naïve Adults Receiving FTC+TAF (Administered as GENVOYA) or FTC+TDF (Administered as STRIBILD) in Studies 104 and 111 (Week 48 and Week 144 analyses^b)

	Week 48 and Week 144	
	FTC+TAF (Administered as GENVOYA) (N = 866)	FTC+TDF (Administered as STRIBILD) (N = 867)
GASTROINTESTINAL DISORDERS		
Nausea	1%	1%
Diarrhea	1%	< 1%
GENERAL DISORDERS AND ADMINISTRATION SITE CONDITIONS		
Fatigue	1%	1%
NERVOUS SYSTEM DISORDERS		
Headache	1%	1%

a Frequencies of adverse reactions are based on Grades 2-4 adverse events attributed to study drugs by the investigator.

b Frequencies of adverse reactions are the same for Week 48 through Week 144.

Rilpivirine-Containing Regimens

The safety assessment of RPV at Week 48 and Week 96 is based on pooled data from 686 patients in the Phase III controlled studies TMC278-C209 (ECHO) and TMC278-C215 (THRIVE) in adult patients with no antiretroviral treatment history who received RPV (25 mg once daily) in combination with other retroviral drugs; most (550) received FTC+TDF as background regimen (see **CLINICAL TRIALS**). In the Week 96 analysis, the median duration of exposure was 104 weeks. The proportion of patients who discontinued treatment with RPV in combination with FTC and TDF due to adverse drug reactions (ADRs) was 2%. Most ADRs occurred during the first 48 weeks of treatment and no new ADR terms were identified between 48 weeks and 96 weeks. Adverse reactions observed in these studies were generally consistent with those seen in previous studies of the individual components (Table 3).

Table 3. Selected Treatment-Emergent Adverse Reactions^a (Grades 2–4) Reported in ≥ 1% of Patients Receiving RPV or Efavirenz (EFV) in Combination with FTC/TDF in Studies C209 and C215 (Week 96)

	RPV + FTC/TDF (N = 550)	EFV + FTC/TDF (N = 546)
GASTROINTESTINAL DISORDER		
Abdominal Pain	2%	2%
Nausea	2%	3%
Vomiting	1%	2%
GENERAL DISORDERS AND ADMINISTRATION SITE CONDITION		
Fatigue	2%	3%
NERVOUS SYSTEM DISORDERS		
Dizziness ^b	1%	7%
Headache	4%	4%
Somnolence	< 1%	1%
PSYCHIATRIC DISORDERS		
Abnormal dreams	2%	5%
Depression	5%	3%
Insomnia	3%	3%
Sleep Disorders	1%	1%
SKIN AND SUBCUTANEOUS TISSUE DISORDERS		
Rash ^b	3%	10%
METABOLISM AND NUTRITION DISORDERS		
Decreased Appetite	1%	1%

• Frequencies of adverse reactions are based on all Grades 2-4 treatment-emergent adverse events, regardless of relationship to study drug.

b p-value < 0.0001 based on Fisher's exact test.

Clinical Trials in Virologically Suppressed Patients

Emtricitabine+Tenofovir Alafenamide-Containing Regimens

No new adverse reactions to FTC+TAF were identified through Week 96 in an open-label clinical trial Study GS-US-292-0109 (Study 109) of virologically suppressed patients who switched treatment from a TDF-containing combination regimen to FTC+TAF given with EVG+COBI as a FDC tablet (administered as GENVOYA) (N = 959).

Rilpivirine-Containing Regimens

No new adverse reactions to RPV given with FTC+TDF as a FDC tablet (administered as COMPLERA) were identified in stable, virologically-suppressed patients who switched to COMPLERA from a regimen containing a ritonavir-boosted protease inhibitor; however, the frequency of adverse reactions increased by 20% (GS-US-264-0106) after switching to COMPLERA.

Clinical Trials in Adult Patients with Renal Impairment

Emtricitabine+Tenofovir Alafenamide-Containing Regimens

The safety of FTC+TAF was evaluated through Week 144 in an open-label clinical study GS-US-292-0112 (Study 112) in 248 HIV-1 infected patients who were either treatment-naïve (N = 6) or virologically suppressed (N = 242) with mild to moderate renal impairment (eGFR by Cockcroft-Gault method 30 - 69 mL/min) received FTC+TAF given with EVG+COBI as a FDC tablet (administered as GENVOYA). The safety profile of FTC+TAF in patients with mild to moderate renal impairment was similar to that in patients with normal renal function (eGFR \geq 80 mL/min) (see **CLINICAL TRIALS**).

Patients coinfecting with Hepatitis B and/or Hepatitis C virus

Rilpivirine-Containing Regimens

In patients coinfecting with hepatitis B or C virus receiving RPV in studies C209 and C215, the incidence of hepatic enzyme elevation was higher than in patients receiving RPV who were not coinfecting. The same increase was also observed in the EFV arm. The pharmacokinetic exposure of RPV in coinfecting patients was comparable to that in patients without coinfection.

8.3. Less Common Clinical Trial Adverse Drug Reactions (< 1%)

Emtricitabine+Tenofovir Alafenamide-Containing Regimens

In addition to the adverse reactions presented in Table 2, abdominal pain, dyspepsia, flatulence, rash, and vomiting occurred at a frequency of < 1% and/or at severity of Grade 1 in the FTC+TAF group (administered as GENVOYA).

Rilpivirine-Containing Regimens

Treatment-emergent ADRs of at least moderate intensity (\geq Grade 2) occurring in less than 1% of antiretroviral treatment-naïve subjects receiving RPV are listed below. Some adverse events (*) have been included because of investigator's assessment of potential causal relationship and were considered serious or have been reported in more than 1 subject treated with RPV.

Gastrointestinal Disorders: Abdominal discomfort

Hepatobiliary Disorders: cholecystitis*, cholelithiasis*

Psychiatric Disorders: Depressed mood, anxiety

Renal and Urinary Disorders: glomerulonephritis membranous*, glomerulonephritis mesangioproliferative*, nephrolithiasis*

Adverse Reactions from Clinical Trials of the Components of ODEFSEY

For information on the safety profiles of EMTRIVA or Edurant, consult the Product Monographs for these products.

8.4. Abnormal Laboratory Findings: Hematologic, Clinical Chemistry and Other Quantitative Data

Emtricitabine+Tenofovir Alafenamide-Containing Regimens

The frequency of laboratory abnormalities (Grades 3-4) occurring in at least 2% of patients receiving FTC+TAF given with EVG+COBI as a FDC tablet (administered as GENVOYA) in Studies 104 and 111 are presented in Table 4.

Table 4. Laboratory Abnormalities (Grades 3-4) Reported in ≥ 2% of Patients Receiving FTC+TAF (Administered as GENVOYA) in Studies 104 and 111 (Week 48 and Week 144 Analyses)

Laboratory Parameter Abnormality ^a	Week 48		Week 144	
	FTC+TAF (Administered as GENVOYA) (N = 866)	FTC+TDF (Administered as STRIBILD) (N = 867)	FTC+TAF (Administered as GENVOYA) (N = 866)	FTC+TDF (Administered as STRIBILD) (N = 867)
Amylase (> 2.0 x ULN)	<2%	3%	3%	5%
ALT (> 5.0 x ULN)	<2%	<2%	3%	3%
AST (> 5.0 x ULN)	<2%	<2%	3%	4%
Creatine Kinase (≥ 10.0 x ULN)	7%	6%	11%	10%
LDL-cholesterol (fasted) (> 4.92 mmol/L)	5%	2%	11%	5%
Total Cholesterol (fasted) (> 7.77 mmol/L)	<2%	1%	4%	3%
Lipase ^b (≥ 3.0 x ULN)	4%	8%	5%	8%
Urine RBC (Hematuria) (> 75 RBC/HPF)	<2%	2%	3%	3%

1. Frequencies are based on treatment-emergent laboratory abnormalities.

2. Lipase test was performed only for patients with serum amylase > 1.5 x ULN (N = 90 for GENVOYA arm, N = 113 for STRIBILD arm at Week 48; N = 127 for GENVOYA arm, N = 154 for STRIBILD arm at Week 144).

Rilpivirine-Containing Regimens

Laboratory abnormalities observed in studies C209 and C215 were generally consistent with those seen in other studies of the individual components (Table 5).

Table 5. Significant Laboratory Abnormalities (Grades 3-4) Reported in Patients Who Received RPV or EFV in Combination with FTC/TDF in Studies C209 and C215 (Week 96)

Laboratory Parameter Abnormality	RPV + FTC/TDF (N = 550)	EFV + FTC/TDF (N = 546)
Creatinine (> 1.8 ULN)	0.2%	0.2%
Pancreatic Amylase (> 2 ULN ^a)	4.2%	4.9%
Lipase (> 3 ULN)	0.9%	1.5%
Decreased Hemoglobin (< 4.5 mmol/L)	0.2%	0.6%
Decreased Platelet Count (< 49.999 x 10 ⁹ /L)	0.0%	0.2%
Decreased White Blood Cell Count (< 1.499 x 10 ⁹ /L)	0.2%	0.2%
AST (> 5 ULN)	2.6%	3.6%
ALT (> 5 ULN)	1.6%	3.5%
Increased Bilirubin (> 2.5 ULN)	0.5%	0.4%
Total Cholesterol (fasted) (> 7.77 mmol/L)	0.2%	2.2%
LDL-Cholesterol (fasted) (≥ 4.91 mmol/L)	0.9%	3.9%
Triglycerides (fasted) (≥ 8.49 mmol/L)	0.5%	2.6%

a ULN = Upper limit of normal value.

Serum Lipids

Emtricitabine+Tenofovir Alafenamide-Containing Regimens

Patients receiving FTC+TAF (administered as GENVOYA) experienced higher increases in serum lipids than those receiving FTC+TDF (administered as STRIBILD). In the clinical trials of FTC+TAF, and of FTC+TDF, both given with EVG+COBI as a FDC tablet (administered as GENVOYA and STRIBILD, respectively), a similar percentage of patients receiving FTC+TAF, and FTC+TDF were on lipid lowering agents at baseline (2% and 3%, respectively). Similar percentages of subjects in each treatment group initiated lipid-modifying medications through Week 144, 5.5% and 5.8% in subjects receiving FTC+TAF and FTC+TDF, respectively.

Changes from baseline in total cholesterol, HDL-cholesterol, LDL-cholesterol, triglycerides, and total cholesterol to HDL ratio at Week 48 and Week 144 are presented in Table 6.

Table 6. Lipid Values, Mean Change from Baseline, Reported in Patients Receiving FTC+TAF (Administered as GENVOYA) or FTC+TDF (Administered as STRIBILD) in Studies 104 and 111^a (Week 48 and Week 144 Analyses)

	Week 48				Week 144			
	FTC+TAF (Administered as GENVOYA) (N = 866)		FTC+TDF (Administered as STRIBILD) (N = 867)		FTC+TAF (Administered as GENVOYA) (N = 866)		FTC+TDF (Administered as STRIBILD) (N = 867)	
	Baseline	Change ^b at Week 48	Baseline	Change ^b at Week 48	Baseline	Change ^c at Week 144	Baseline	Change ^c at Week 144
Total Cholesterol (fasted) mmol/L	4.19 [N = 757]	+0.78 [N = 757]	4.29 [N = 742]	+0.34 [N = 742]	4.19 [N=647]	+0.80 [N=647]	4.27 [N=627]	+0.6 [N=627]
HDL- cholesterol (fasted) mmol/L	1.19 [N = 757]	+0.18 [N = 757]	1.16 [N = 742]	+0.10 [N = 742]	1.21 [N=647]	+0.18 [N=647]	1.19 [N=627]	+0.08 [N=627]
LDL- cholesterol (fasted) mmol/L	2.69 [N = 753]	+0.39 [N = 753]	2.77 [N = 744]	+0.08 [N = 744]	2.66 [N=643]	+0.52 [N=643]	2.77 [N=628]	+0.21 [N=628]
Triglycerides (fasted) mmol/L	1.28 [N = 757]	+0.33 [N = 757]	1.34 [N = 742]	+0.11 [N = 742]	1.25 [N=647]	+0.33 [N=647]	1.30 [N=627]	+0.19 [N=627]
Total Cholesterol to HDL ratio	3.7 [N = 757]	0.2 [N = 757]	3.9 [N = 742]	0 [N = 742]	3.7 [N=647]	0.2 [N=647]	3.8 [N=627]	0.1 [N=627]

- a. Excludes patients who received lipid lowering agents during the treatment period.
 b. The change from baseline is the mean of within-patient changes from baseline for patients with both baseline and Week 48 values.
 c. The change from baseline is the mean of within-patient changes from baseline for patients with both baseline and Week 144 values.

Rilpivirine-Containing Regimens

Changes from baseline in total cholesterol, LDL-cholesterol, HDL-cholesterol and triglycerides are presented in Table 7. The mean changes from baseline were smaller in the RPV arm versus the EFV arm. The impact of such findings has not been demonstrated.

Table 7. Lipid Values, Mean Change from Baseline, Reported in Patients Receiving RPV or EFV in Combination with FTC/TDF in Studies C209 and C215 (Week 96)^a

	RPV + FTC/TDF (N = 550)		EFV + FTC/TDF (N = 546)	
	Baseline	Change ^b at Week 96	Baseline	Change ^b at Week 96
Total Cholesterol (fasted) ^c mmol/L	4.19 [N = 430]	0.05 [N = 430]	4.14 [N = 401]	0.67 [N = 401]
HDL-cholesterol (fasted) ^c mmol/L	1.09 [N = 429]	0.10 [N = 429]	1.03 [N = 399]	0.28 [N = 399]
LDL-cholesterol (fasted) ^c mmol/L	2.51 [N = 427]	-0.03 [N = 427]	2.48 [N = 397]	0.36 [N = 397]
Triglycerides (fasted) ^c mmol/L	1.39 [N = 430]	-0.16 [N = 430]	1.43 [N = 401]	0.07 [N = 401]

1. Excludes patients who received lipid-lowering agents during the treatment period.
2. The change from baseline is the mean of within-patient changes from baseline for patients with both baseline and Week 96 values.
 - p-value < 0.0001, Wilcoxon rank-sum test for treatment comparison of change from baseline.

Adrenal Function

Rilpivirine-Containing Regimens

In the pooled analysis of Phase III trials, at Week 48, the overall mean change from baseline in basal cortisol showed a decrease of 13.1 nmol/L in the RPV group and an increase of 9.0 nmol/L in the control (EFV) group. At Week 96, the overall mean change from baseline in basal cortisol showed a decrease of 19.1 nmol/L in the RPV group and a decrease of 0.6 nmol/L in the control group. At Week 48 and Week 96, the mean change from baseline in ACTH-stimulated cortisol levels was lower in the RPV group ($+16.5 \pm 6.14$ nmol/L and $+18.4 \pm 8.36$ nmol/L, respectively) than in the control group ($+58.1 \pm 6.66$ nmol/L and $+54.1 \pm 7.24$ nmol/L, respectively). Mean values for both basal and ACTH-stimulated cortisol values at Week 48 and Week 96 were within the normal range. Overall, there were no serious adverse events, deaths, or treatment discontinuations that could clearly be attributed to adrenal insufficiency. The effects on adrenal function are specific to RPV and not dependent on the background regimen.

Electrocardiogram Findings

Rilpivirine-Containing Regimens

In a Phase II clinical trial in antiretroviral-naïve HIV-1 infected patients, RPV at doses of 25 mg, 75 mg, and 150 mg once daily was associated with dose-dependent QTc prolongation. A pooled analysis of data from two Phase III clinical trials of

antiretroviral-naïve HIV-1 infected patients who received either RPV 25 mg once daily or control (EFV), showed statistically significant mean increase from baseline in the QTc interval at Weeks 48 and 96. During treatment with RPV 25 mg, the mean change from baseline in QTc increased through Week 48 without reaching plateau and remained stable between Week 48 and Week 96 (11.4 ms [95% CI 10.1, 12.8] and 12.4 ms [95% CI 11.0, 13.7], respectively). These trials excluded patients with high risk factors for proarrhythmia. The clinical relevance of these findings is unknown (see

DRUG INTERACTIONS, QT Prolonging Drugs; ACTION AND CLINICAL PHARMACOLOGY, Effects on Electrocardiogram).

8.5. Post-Market Adverse Drug Reactions

In addition to the adverse reaction reports from clinical trials, the following possible adverse reactions have been identified during post-approval use of FTC-, RPV-, or TAF-containing regimens. Because these events have been reported voluntarily from a population of unknown size, estimates of frequency cannot be made. These events have been considered possible adverse reactions due to a combination of their seriousness, frequency of reporting or potential causal relationship with treatment.

Emtricitabine

The following adverse experiences have been reported in post-marketing experience without regard to causality; some events represent a single report.

<i>Blood and lymphatic system disorders:</i>	Thrombocytopenia
<i>Gastrointestinal disorders:</i>	Pancreatitis
<i>General disorders and administrative site conditions:</i>	Pyrexia
<i>Metabolism and nutrition disorders:</i>	Lactic acidosis

Rilpivirine-Containing Regimens

<i>Metabolism and nutrition disorders:</i>	Weight increased
<i>Skin and subcutaneous tissue disorders:</i>	Severe skin reactions with systemic symptoms (including rashes accompanied by fever, blisters, conjunctivitis, angioedema, elevated liver function tests, and/or eosinophilia)
<i>Renal and genitourinary disorders:</i>	Nephrotic syndrome

Tenofovir Alafenamide-Containing Regimens

Skin and subcutaneous tissue disorders: Angioedema, urticaria

9. DRUG INTERACTIONS

9.1. Drug-Drug Interactions

ODEFSEY is indicated for use as a complete regimen for the treatment of HIV-1 infection; therefore ODEFSEY should not be coadministered with other antiretroviral medications. (see **WARNINGS AND PRECAUTIONS, General**).

As ODEFSEY contains FTC, RPV, and TAF, any interactions that have been identified with these agents individually may occur with ODEFSEY.

Drugs Inhibiting Cathepsin A

Coadministration of ODEFSEY with drugs that inhibit the lysosomal carboxypeptidase cathepsin A (CatA) may decrease metabolism of TAF to tenofovir in target cells, which may lead to reduced therapeutic effect of ODEFSEY and development of resistance (see

DRUG INTERACTIONS, Table 8).

Drugs Inducing or Inhibiting CYP3A Enzymes

Rilpivirine is primarily metabolized by cytochrome P450 (CYP) 3A; drugs that induce or inhibit CYP3A may thus affect the clearance of RPV (see **CONTRAINDICATIONS** and **ACTION AND CLINICAL PHARMACOLOGY**). Coadministration of RPV and drugs that induce CYP3A may result in decreased plasma concentrations of RPV, loss of virologic response, and possible resistance to RPV or to the class of NNRTIs which could potentially reduce the therapeutic effect of ODEFSEY. Coadministration of RPV and drugs that inhibit CYP3A may result in increased plasma concentrations of RPV.

Drugs Affecting P-glycoprotein and Breast Cancer Resistance Protein

Tenofovir alafenamide, a component of ODEFSEY, is transported by P-glycoprotein (P-gp) and breast cancer resistance protein (BCRP). Drugs that strongly affect P-gp and BCRP activity may lead to changes in TAF absorption (see Table 8). Drugs that induce P-gp activity are expected to decrease the absorption of TAF, resulting in decreased plasma concentration of TAF, which may lead to loss of therapeutic effect of ODEFSEY and development of resistance. Coadministration of ODEFSEY with other drugs that inhibit P-gp and BCRP may increase the absorption and plasma concentration of TAF.

Drugs Increasing Gastric pH

Coadministration of RPV with drugs that increase gastric pH (such as proton pump inhibitors, H₂-receptor antagonists, and antacids) may decrease plasma concentrations of RPV and lead to loss of virologic response and possible resistance to RPV or to the NNRTI class of antiretrovirals (see Table 8).

QT Prolonging Drugs

There is limited information available on the potential for a pharmacodynamic interaction between RPV and drugs that prolong the QTc interval of the electrocardiogram. In a study of healthy subjects, supratherapeutic doses of RPV (75 mg once daily and 300 mg once daily) have been shown to prolong the QTc interval of the electrocardiogram (see **ACTION AND CLINICAL PHARMACOLOGY**). ODEFSEY should be used with caution when coadministered with a drug with a known risk of QTc prolongation.

Rilpivirine is a substrate for CYP3A4. Plasma levels of RPV can be increased by inhibitors of CYP3A4. Drugs that inhibit CYP3A4 include, but are not limited to, azole antifungal agents (e.g., ketoconazole, fluconazole, voriconazole), clarithromycin, erythromycin, and telithromycin. Caution should be observed if these drugs are to be used concomitantly with ODEFSEY.

Caution should be observed when using ODEFSEY with drugs that can disrupt electrolyte levels, including, but not limited to, the following: loop, thiazide, and related diuretics; laxatives and enemas; amphotericin B; high dose corticosteroids.

ODEFSEY should be used with caution when coadministered with a drug with a known risk of Torsade de Pointes (see **WARNINGS AND PRECAUTIONS, Cardiovascular**).

Established and Other Potentially Significant Interactions

Drug interaction information for ODEFSEY with potential concomitant drugs is summarized in Table 8. The drug interactions described are based on studies conducted with either ODEFSEY, the components of ODEFSEY (FTC, RPV and TAF) as individual agents, or are potential drug interactions that may occur with ODEFSEY. As ODEFSEY should not be coadministered with other antiretroviral products, information regarding drug-drug interactions with other antiretroviral products (including protease inhibitors and NNRTIs) is not provided (see **WARNINGS AND PRECAUTIONS, General**). The table includes potentially significant interactions, but is not all inclusive (see also **CONTRAINDICATIONS**).

Table 8. Established and Other Potentially Significant^a Drug Interactions

Concomitant Drug Class: Drug Name	Effect^b	Clinical Comment
Antacids: antacids (e.g., aluminium, magnesium hydroxide, or calcium carbonate)	↔ rilpivirine (antacids taken at least 2 hours before or at least 4 hours after rilpivirine) ↓ rilpivirine (concomitant intake)	Antacids should only be administered either at least 2 hours before or at least 4 hours after ODEFSEY.
Anticonvulsants: carbamazepine oxcarbazepine phenobarbital phenytoin	↓ rilpivirine ↓ tenofovir alafenamide	ODEFSEY is contraindicated with these anticonvulsants as coadministration may cause significant decreases in RPV and TAF plasma concentrations (induction of CYP3A and P-gp). This may result in loss of therapeutic effect of ODEFSEY and possible development of resistance to RPV and other NNRTIs.
Antimycobacterials: rifabutin ^d rifampin ^{c,d} rifapentine ^e	↓ rilpivirine ^d ↓ tenofovir alafenamide	Concomitant use of ODEFSEY with rifampin, rifabutin, and rifapentine (induction of CYP3A and P-gp) may cause significant decreases in RPV and TAF plasma concentrations. This may result in loss of therapeutic effect of ODEFSEY. Coadministration of ODEFSEY with rifabutin is not recommended. Coadministration of ODEFSEY with rifampin and rifapentine is contraindicated.
Azole Antifungal Agents: fluconazole itraconazole ketoconazole ^{c,d} posaconazole voriconazole	↑ rilpivirine ^{c,d} ↓ ketoconazole ^{c,d} ↑ tenofovir alafenamide	Concomitant use of ODEFSEY with azole antifungal agents (CYP3A and P-gp inhibitors) may cause an increase in the plasma concentrations of RPV (inhibition of CYP3A enzymes) and TAF (inhibition of P-gp). No dose adjustment is required when ODEFSEY is coadministered with azole antifungal agents.
Glucocorticoids: dexamethasone (systemic)	↓ rilpivirine	ODEFSEY is contraindicated in combination with systemic dexamethasone as coadministration may cause significant decreases in RPV plasma concentrations (induction of CYP3A and P-gp). This may result in loss of therapeutic effect of ODEFSEY and possible development of resistance to RPV and other NNRTIs. Alternatives should be considered, particularly for long-term use.

Concomitant Drug Class: Drug Name	Effect ^b	Clinical Comment
H ₂ -Receptor Antagonists: cimetidine famotidine ^{c,d} nizatidine ranitidine	↔ rilpivirine (famotidine taken 12 hours before rilpivirine or 4 hours after rilpivirine) ↓ rilpivirine (famotidine taken 2 hours before rilpivirine)	The combination of ODEFSEY and H ₂ -receptor antagonists should be used with caution as coadministration may cause significant decreases in RPV plasma concentrations (increase in gastric pH). H ₂ -receptor antagonists should only be administered at least 12 hours before or at least 4 hours after ODEFSEY.
Immunosuppressants: cyclosporine	↑ tenofovir alafenamide	Coadministration with cyclosporine may result in increased plasma concentration of TAF. Therapeutic monitoring is recommended upon coadministration with ODEFSEY.
Macrolide or Ketolide Antibiotics clarithromycin erythromycin telithromycin	↑ rilpivirine ↔ clarithromycin ↔ erythromycin ↔ telithromycin	Concomitant use of ODEFSEY with clarithromycin, erythromycin or telithromycin may cause an increase in the plasma concentrations of RPV (inhibition of CYP3A enzymes). Where possible, alternatives such as azithromycin should be considered.
Narcotic Analgesics: methadone ^d	↓ R (-) methadone ↓ S (+) methadone	No dose adjustments are required when initiating coadministration of methadone with ODEFSEY. However, clinical monitoring is recommended as methadone maintenance therapy may need to be adjusted in some patients.
Proton Pump Inhibitors: omeprazole ^{c,d} lansoprazole rabeprazole pantoprazole esomeprazole	↓ rilpivirine ↓ omeprazole	ODEFSEY is contraindicated with proton pump inhibitors as coadministration may cause significant decreases in RPV plasma concentrations (increase in gastric pH). This may result in loss of therapeutic effect of ODEFSEY and possible development of resistance to RPV and other NNRTIs.

a. This table is not all inclusive.

b. = increase, ↓ = decrease, ↔ = no effect

c. This interaction study has been performed with a dose (150 mg of RPV) higher than the recommended dose for RPV assessing the maximal effect on the coadministered drug. The dosing recommendation is applicable to the recommended dose of RPV 25 mg once daily.

d. The interaction was evaluated in a clinical study. All other drug-drug interactions shown are predicted.

e. Not available in Canada.

Drugs without Clinically Significant Interactions with ODEFSEY

Based on drug interaction studies conducted with ODEFSEY or the components of ODEFSEY, no clinically significant drug interactions have been either observed or are expected when ODEFSEY is combined with the following drugs: acetaminophen, atorvastatin, buprenorphine, chlorzoxazone, digoxin, ethinyl estradiol, famciclovir,

ledipasvir/sofosbuvir, metformin, midazolam, naloxone, norbuprenorphine, norethindrone, norgestimate/ethinyl estradiol, sertraline, sildenafil, simeprevir, sofosbuvir, sofosbuvir/velpatasvir, and sofosbuvir/velpatasvir/voxilaprevir.

Assessment of Drug Interactions

Emtricitabine

In vitro and clinical pharmacokinetic drug-drug interaction studies have shown that the potential for CYP-mediated interactions involving FTC with other medicinal products is low.

Emtricitabine is primarily excreted by the kidneys by a combination of glomerular filtration and active tubular secretion. No drug-drug interactions due to competition for renal excretion have been observed; however, coadministration of FTC with drugs that are eliminated by active tubular secretion may increase concentrations of FTC, and/or the coadministered drug.

Drugs that decrease renal function may increase concentrations of FTC.

Rilpivirine

Rilpivirine is primarily metabolized by cytochrome CYP3A, and drugs that induce or inhibit CYP3A may thus affect the clearance of RPV. Coadministration of ODEFSEY and drugs that induce CYP3A may result in decreased plasma concentrations of RPV and loss of virologic response and possible resistance. Coadministration of ODEFSEY and drugs that inhibit CYP3A may result in increased plasma concentrations of RPV. Coadministration of ODEFSEY with drugs that increase gastric pH may result in decreased plasma concentrations of RPV and loss of virologic response and possible resistance to RPV and to the class of NNRTIs.

Tenofovir Alafenamide

Tenofovir alafenamide is a substrate of P-gp and BCRP transporters. Drugs that strongly affect P-gp and BCRP activity may lead to changes in TAF absorption. Tenofovir alafenamide is not an inhibitor or inducer of CYP3A *in vivo*.

In vitro and clinical pharmacokinetic drug-drug interaction studies have shown that the potential for CYP-mediated interactions involving TAF with other medicinal products is low.

Drug Interaction Studies

The drug interaction studies described in Table 9 to Table 12 were conducted with ODEFSEY or its components (FTC, RPV, or TAF) administered alone.

As ODEFSEY should not be administered with other antiretroviral medications, information regarding drug-drug interactions with other antiretroviral agents is not provided (see **WARNINGS AND PRECAUTIONS**).

The effects of coadministered drugs on the exposure of RPV and TAF are shown in Table 9 and Table 10, respectively. The effects of RPV and TAF on the exposure of coadministered drugs are shown in Table 11 and Table 12, respectively. For information regarding clinical recommendations, see **DRUG INTERACTIONS, Drug-Drug Interactions**.

Table 9. Drug Interactions: Pharmacokinetic Parameters for RPV in the Presence of Co-administered Drugs

Coadministered Drug		RPV Dose (mg) / Schedule	N	Mean Ratio of RPV Pharmacokinetic Parameters With/Without Co-administered Drug (90% CI); No Effect = 1.00		
Drug	Dose (mg) / Schedule			C _{max}	AUC	C _{min}
Acetaminophen	500 single dose	150 once daily ^a	16	1.09 (1.01,1.18)	1.16 (1.10,1.22)	1.26 (1.16,1.38)
Atorvastatin	40 once daily	150 once daily ^a	16	0.91 (0.79,1.06)	0.90 (0.81,0.99)	0.90 (0.84,0.96)
Chlorzoxazone	500 single dose taken 2 hours after RPV	150 once daily ^a	16	1.17 (1.08,1.27)	1.25 (1.16,1.35)	1.18 (1.09,1.28)
Ethinylestradiol/ Norethindrone	0.035 once daily/ 1 mg once daily	25 once daily	15	↔b	↔b	↔b
Famotidine	40 single dose taken 12 hours before RPV	150 single dose ^a	24	0.99 (0.84,1.16)	0.91 (0.78,1.07)	NA
Famotidine	40 single dose taken 2 hours before RPV	150 single dose ^a	23	0.15 (0.12,0.19)	0.24 (0.20,0.28)	NA
Famotidine	40 single dose taken 4 hours after RPV	150 single dose ^a	24	1.21 (1.06,1.39)	1.13 (1.01,1.27)	NA
Ketoconazole	400 once daily	150 once daily ^a	15	1.30 (1.13,1.48)	1.49 (1.31,1.70)	1.76 (1.57, 1.97)
Methadone	60-100 once daily, individualised dose	25 once daily	12	↔b	↔b	↔b
Ledipasvir/ Sofosbuvir	90/400 once daily	25 once daily ^c	42	0.97 (0.92, 1.02)	0.95 (0.91, 0.98)	0.93 (0.89, 0.97)
Omeprazole	20 once daily	25 single dose	15	0.30 (0.24, 0.38)	0.35 (0.28, 0.44)	NA

Coadministered Drug		RPV Dose (mg) / Schedule	N	Mean Ratio of RPV Pharmacokinetic Parameters With/Without Co-administered Drug (90% CI); No Effect = 1.00		
Drug	Dose (mg) / Schedule			C _{max}	AUC	C _{min}
Rifabutin	300 once daily	25 once daily	18	0.69 (0.62, 0.76)	0.58 (0.52, 0.65)	0.52 (0.46, 0.59)
	300 once daily	50 once daily ^a	18	1.43 (1.30, 1.56) ^d	1.16 (1.06, 1.26) ^d	0.93 (0.85, 1.00) ^d
Rifampin	600 once daily	150 once daily ^a	16	0.31 (0.27, 0.36)	0.20 (0.18, 0.23)	0.11 (0.10, 0.13)
Simeprevir	25 once daily	150 once daily	23	1.04 (0.95, 1.30)	1.12 (1.05, 1.19)	1.25 (1.16, 1.35)
Sildenafil	50 single dose	75 once daily ^a	16	0.92 (0.85, 0.99)	0.98 (0.92, 1.05)	1.04 (0.98, 1.09)
Sofosbuvir/velpatasvir	400/100 once daily	25 once daily ^e	24	0.93 (0.88, 0.98)	0.95 (0.90, 1.00)	0.96 (0.90, 1.03)
Sofosbuvir/ velpatasvir/ voxilaprevir	400/100/100 + 100 voxilaprevir ^f once daily	25 once daily ^c	30	0.79 (0.74, 0.84)	0.80 (0.76, 0.85)	0.82 (0.77, 0.87)

CI = Confidence Interval; N = maximum number of subjects with data; NA = not available; ↔ = no change

a This interaction study has been performed with a dose higher than the recommended dose for Edurant (25 mg once daily) assessing the maximal effect on the co-administered drug.

b Comparison based on historic controls.

c Study conducted with ODEFSEY (FTC/RPV/TAF).

d Compared to RPV 25 mg once daily alone.

e Study conducted with COMPLERA (FTC/RPV/TDF).

f Study conducted with additional voxilaprevir 100 mg to achieve voxilaprevir exposures expected in HCV-infected patients

Table 10. Drug Interactions: Changes in Pharmacokinetic Parameters for TAF in the Presence of the Coadministered Drug^a

Coadministered Drug		TAF Dose (mg) / Schedule	N	Mean Ratio of TAF Pharmacokinetic Parameters (90% CI) ^b ; No effect = 1.00		
Drug	Dose (mg) / Schedule			C _{max}	AUC	C _{min}
Cobicistat	150 once daily	8 once daily	12	2.83 (2.20, 3.65)	2.65 (2.29, 3.07)	NA
Efavirenz ^c	600 once daily	40 once daily ^d	11	0.78 (0.58, 1.05)	0.86 (0.72, 1.02)	NA
Ledipasvir/ Sofosbuvir	90/400 once daily	25 once daily ^e	42	1.03 (0.94, 1.14)	1.32 (1.25, 1.40)	NA
Sertraline	50 single dose	10 once daily ^f	19	1.00	0.96	NA

ODEFSEY (emtricitabine/rilpivirine*/tenofovir alafenamide**) tablets
 *as rilpivirine hydrochloride **as tenofovir alafenamide hemifumarate
 Product Monograph

				(0.86, 1.16)	(0.89, 1.03)	
Sofosbuvir/ velpatasvir/ voxilaprevir	400/100/100 + 100 voxilaprevir ^g once daily	25 once daily ^e	30	1.32 (1.17, 1.48)	1.52 (1.43, 1.61)	NA

CI = Confidence Interval; NA = not available

a All interaction studies conducted in healthy volunteers.

b All No Effect Boundaries are 70% -143% unless otherwise specified.

c A moderate P-gp and CYP3A4 inducer.

d Study conducted with DESCOVY (FTC/TAF).

e Study conducted with ODEFSEY (FTC/RPV/TAF).

f Study conducted with GENVOYA (EVG/COBI/FTC/TAF).

g Study conducted with additional voxilaprevir 100 mg to achieve voxilaprevir exposures expected in HCV-infected patients.

Table 11. Drug Interactions: Pharmacokinetic Parameters for Coadministered Drugs in the Presence of RPV

Co-administered Drug		RPV Dose (mg)/Schedule	N	Mean Ratio of Co-administered Drug Pharmacokinetic Parameters With/Without EDURANT (90% CI); No Effect = 1.00		
Drug	Dose (mg)/Schedule			C _{max}	AUC	C _{min}
Analgesic						
Acetaminophen	500 single dose	150 once daily ^a	16	0.97 (0.86,1.10)	0.92 (0.85,0.99)	NA
Antifungal Agent						
Ketoconazole	400 once daily	150 once daily ^a	14	0.85 (0.80, 0.90)	0.76 (0.70, 0.82)	0.34 (0.25, 0.46)
Antihyperglycemic Agent						
Metformin	850 single dose	25 once daily	20	1.02 (0.95, 1.10)	0.97 (0.90, 1.06) ^c	NA
Antimicrobacterials						
Rifampin	600 once daily	150 once daily ^a	16	1.02 (0.93, 1.12)	0.99 (0.92, 1.07)	NA
25-desacetylriofampin			16	1.00 (0.87, 1.15)	0.91 (0.77, 1.07)	NA
Centrally Acting Skeletal Muscle Relaxants						
Chlorzoxazone	500 single dose taken 2 hours after RPV	150 once daily ^a	16	0.98 (0.85, 1.13)	1.03 (0.95, 1.13)	NA
Cardiac Glycoside						

ODEFSEY (emtricitabine/rilpivirine*/tenofovir alafenamide**) tablets
 *as rilpivirine hydrochloride **as tenofovir alafenamide hemifumarate
 Product Monograph

Co-administered Drug		RPV Dose (mg)/Schedule	N	Mean Ratio of Co-administered Drug Pharmacokinetic Parameters With/Without EDURANT (90% CI); No Effect = 1.00		
Drug	Dose (mg)/Schedule			C _{max}	AUC	C _{min}
Digoxin	0.5 single dose	25 once daily	22	1.06 (0.97, 1.17)	0.98 (0.93, 1.04) ^b	NA
HCV Antivirals						
Ledipasvir	90/400 once daily	25 once daily	41	1.01 (0.97, 1.05)	1.02 (0.97, 1.06)	1.02 (0.98, 1.07)
Sofosbuvir				0.96 (0.89, 1.04)	1.05 (1.01, 1.09)	NA
GS-331007 ^d				1.08 (1.05, 1.11)	1.08 (1.06, 1.10)	1.10 (1.07, 1.12)
Sofosbuvir	400/100 once daily	25 once daily ^e	24	1.09 (0.95, 1.25)	1.16 (1.10, 1.24)	NA
GS-331007 ^d				0.96 (0.90, 1.01)	1.04 (1.00, 1.07)	1.12 (1.07, 1.17)
Velpatasvir				0.96 (0.85, 1.10)	0.99 (0.88, 1.11)	1.02 (0.91, 1.15)
Sofosbuvir	400/100/100 + 100 voxilaprevir ^f once daily	25 once daily	30	0.95 (0.86, 1.05)	1.01 (0.97, 1.06)	NA
GS-331007 ^d				1.02 (0.98, 1.06)	1.04 (1.01, 1.06)	NA
Velpatasvir				1.05 (0.96, 1.16)	1.01 (0.94, 1.07)	1.01 (0.95, 1.09)
Voxilaprevir				0.96 (0.84, 1.11)	0.94 (0.84, 1.05)	1.02 (0.92, 1.12)
Simeprevir	150 once daily	25 once daily	21	1.10 (0.97, 1.26)	1.06 (0.94, 1.19)	0.96 (0.83, 1.11)
HMG-CoA Reductase Inhibitors						
Atorvastatin	40 once daily	150 once daily ^a	16	1.35 (1.08, 1.68)	1.04 (0.97, 1.12)	0.85 (0.69, 1.03)

Co-administered Drug		RPV Dose (mg)/Schedule	N	Mean Ratio of Co-administered Drug Pharmacokinetic Parameters With/Without EDURANT (90% CI); No Effect = 1.00		
Drug	Dose (mg)/Schedule			C _{max}	AUC	C _{min}
2-hydroxy-atorvastatin		25 once daily	16	1.58 (1.33, 1.87)	1.39 (1.29, 1.50)	1.32 (1.10, 1.58)
4-hydroxy-atorvastatin			16	1.28 (1.15, 1.43)	1.23 (1.13, 1.33)	NA
Oral Contraceptives						
Ethinylestradiol	0.035 once daily	25 once daily	17	1.17 (1.06, 1.30)	1.14 (1.10, 1.19)	1.09 (1.03, 1.16)
Norethindrone	1 once daily		17	0.94 (0.83, 1.06)	0.89 (0.84, 0.94)	0.99 (0.90, 1.08)
Opiate Agonists						
R (-) methadone	60-100 once daily, individualized dose	25 once daily	13	0.86 (0.78, 0.95)	0.84 (0.74, 0.95)	0.78 (0.67, 0.91)
S (+) methadone			13	0.87 (0.78, 0.97)	0.84 (0.74, 0.96)	0.79 (0.67, 0.92)
Proton Pump Inhibitors						
Omeprazole	20 once daily	150 once daily ^a	15	0.86 (0.68, 1.09)	0.86 (0.76, 1.03)	NA
Vasodilating Agent						
Sildenafil	50 single dose	75 once daily ^a	16	0.93 (0.80, 1.08)	0.97 (0.87, 1.08)	NA
N-desmethyl-sildenafil			16	0.90 (0.80, 1.02)	0.92 (0.85, 0.99) ^b	NA

CI = Confidence Interval; N = maximum number of subjects with data; NA = not available

a This interaction study has been performed with a dose higher than the recommended dose of Edurant (25 mg once daily) assessing the maximal effect on the co-administered drug.

b AUC_(0-last)

c N (maximum number of subjects with data for AUC_(0-∞)) = 15

d The predominant circulating nucleoside metabolite of sofosbuvir.

e Study conducted with COMPLERA (FTC/RPV/TDF).

f Study conducted with additional voxilaprevir 100 mg to achieve voxilaprevir exposures expected in HCV-infected patients.

Table 12. Drug Interactions: Changes in Pharmacokinetic Parameters for Coadministered Drug in the Presence of TAF^a

Coadministered Drug		TAF Dose (mg) / Schedule	N	Mean Ratio of Coadministered Drug Pharmacokinetic Parameters (90% CI) ^b ; No effect = 1.00		
Drug	Dose (mg)/Schedule			C _{max}	AUC	C _{min}
Benzodiazepines						
Midazolam ^b	2.5 single dose, orally	25 once daily	18	1.02 (0.92, 1.13)	1.13 (1.04, 1.23)	NA
	1 single dose, IV			0.99 (0.89, 1.11)	1.08 (1.04, 1.13)	NA
HCV Antivirals						
Ledipasvir	90/400 once daily	25 once daily ^c	41	1.01 (0.97, 1.05)	1.02 (0.97, 1.06)	1.02 (0.98, 1.07)
Sofosbuvir				0.96 (0.89, 1.04)	1.05 (1.01, 1.09)	NA
GS-331007 ^d				1.08 (1.05, 1.11)	1.08 (1.06, 1.10)	1.10 (1.07, 1.12)
Sofosbuvir	400 /100 /100 + 100 ^f once daily	25 once daily ^c	30	0.95 (0.86, 1.05)	1.01 (0.97, 1.06)	NA
GS-331007 ^d				1.02 (0.98, 1.06)	1.04 (1.01, 1.06)	NA
Velpatasvir				1.05 (0.96, 1.16)	1.01 (0.94, 1.07)	1.01 (0.95, 1.09)
Voxilaprevir				0.96 (0.84, 1.11)	0.94 (0.84, 1.05)	1.02 (0.92, 1.12)
Oral Contraceptives						
Norelgestromin	norgestimate 0.180/0.215/0.250 once daily / ethinyl estradiol 0.025 once daily	25 once daily ^e	15	1.17 (1.07, 1.26)	1.12 (1.07, 1.17)	1.16 (1.08, 1.24)
Norgestrel				1.10 (1.02, 1.18)	1.09 (1.01, 1.18)	1.11 (1.03, 1.20)
Ethinyl estradiol				1.22 (1.15, 1.29)	1.11 (1.07, 1.16)	1.02 (0.92, 1.12)

NA = Not Available; IV = intravenous

a All interaction studies conducted in healthy volunteers.

b A sensitive CYP3A4 substrate.

c Study conducted with ODEFSEY (FTC/RPV/TAF).

d The predominant circulating nucleoside metabolite of sofosbuvir.

e Study conducted with DESCOVY (FTC/TAF).

f Study conducted with additional voxilaprevir 100 mg to achieve voxilaprevir exposures expected in HCV-infected patients.

9.2. Drug-Food Interactions

Interactions with food have not been established.

Grapefruit or grapefruit juice can inhibit CYP3A enzyme activity and should be avoided with ODEFSEY.

Effect of Food on Absorption

It is recommended that ODEFSEY be taken with a meal (see **ACTION AND CLINICAL PHARMACOLOGY, Pharmacokinetics**).

9.3. Drug-Herb Interactions

Coadministration of St. John's wort (*Hypericum perforatum*), a potent CYP3A inducer, may significantly decrease RPV and TAF plasma concentrations, which may result in loss of therapeutic effect and development of resistance.

Coadministration of ODEFSEY with St. John's wort is contraindicated.

9.4. Drug-Laboratory Interactions

Interactions of ODEFSEY with laboratory tests have not been established.

10. ACTION AND CLINICAL PHARMACOLOGY

10.1. Mechanism of Action

ODEFSEY is a fixed-dose combination single tablet regimen of the antiretroviral drugs FTC, RPV, and TAF (see **MICROBIOLOGY, Antiviral Activity**).

Emtricitabine

Emtricitabine, a synthetic nucleoside analog of cytidine, is phosphorylated by cellular enzymes to form FTC 5'-triphosphate. Emtricitabine 5'-triphosphate inhibits the activity of the HIV-1 reverse transcriptase by competing with the natural substrate deoxycytidine 5'-triphosphate and by being incorporated into nascent viral DNA which results in chain termination.

Emtricitabine has activity that is specific to human immunodeficiency virus (HIV-1 and HIV-2) and HBV.

Emtricitabine triphosphate is a weak inhibitor of mammalian DNA polymerases that include mitochondrial DNA polymerase γ and there was no evidence of toxicity to mitochondria *in vitro* and *in vivo*.

Rilpivirine

Rilpivirine is a diarylpyrimidine NNRTI of HIV-1. RPV activity is mediated by noncompetitive inhibition of HIV-1 reverse transcriptase. RPV does not inhibit the human cellular DNA polymerase α , β , and mitochondrial DNA polymerase γ .

Tenofovir Alafenamide

Tenofovir alafenamide is a phosphoramidate prodrug of tenofovir (2'-deoxyadenosine monophosphate analogue) and differs from TDF which is another prodrug of tenofovir. Tenofovir alafenamide is permeable into cells and due to increased plasma stability and intracellular activation through hydrolysis by cathepsin A, TAF is more efficient (> 4-fold at clinical doses) than TDF in loading tenofovir into peripheral blood mononuclear cells (PBMCs) (including lymphocytes and other HIV target cells) and macrophages. Intracellular tenofovir is subsequently phosphorylated to the pharmacologically active metabolite tenofovir diphosphate. Tenofovir diphosphate inhibits HIV replication through incorporation into viral DNA by the HIV reverse transcriptase, which results in DNA chain-termination.

Tenofovir has activity that is specific to human immunodeficiency virus (HIV-1 and HIV-2). Tenofovir alafenamide displayed antiviral activity in cell culture against all HIV-1 groups. *In vitro* studies have shown that both FTC and tenofovir can be fully phosphorylated when combined in cells. Tenofovir diphosphate is a weak inhibitor of mammalian DNA polymerases that include mitochondrial DNA polymerase γ . In the *in vitro* study, TAF did not significantly affect mitochondrial DNA in HepG2 cells.

10.2. Pharmacodynamics

Effects on Electrocardiogram

The effect of RPV on the QTc interval of the ECG was evaluated in two Phase I studies in healthy adult volunteers. Rilpivirine at the recommended therapeutic dose of 25 mg q.d. was examined in a double-blind, double-dummy, randomized, placebo- and active-controlled three-way crossover study in healthy adult volunteers (N = 60, 35M/25F), with 13 ECG recordings over 24 hours on day 11 of treatment (steady-state). Rilpivirine at the dose of 25 mg q.d. was not associated with a statistically significant or clinically relevant effect on the QTc interval. Rilpivirine at doses of 75 mg q.d., and 300 mg q.d. was studied in a double-blind, double-dummy, randomized, placebo and active controlled, three-way crossover study in healthy adult volunteers (N = 41, 22F/19M), with 13 ECG recordings over 24 hours on day 1 and day 11 of treatment. On day 11 of treatment (steady-state), the maximum mean QTc interval prolongation (baseline- and placebo-adjusted) was 10.7 (90% CI 6.1, 15.3) ms in the 75 mg q.d. treatment arm and 23.3 (90% CI 18.0, 28.7) ms at 4.5 h post-dosing in the 300 mg q.d. arm.

For QTc interval effects with long-term treatment in the target patient population see **ADVERSE REACTIONS, Electrocardiogram Findings**. See also **WARNINGS AND PRECAUTIONS, Cardiovascular** and

DRUG INTERACTIONS, QT Prolonging Drugs.

In a thorough QT/QTc study in 48 healthy subjects, TAF at the therapeutic dose or at a suprathreshold dose, approximately 5 times the recommended therapeutic dose, did not affect the QT/QTc interval and did not prolong the PR interval. The effect of FTC on the QT interval is not known.

10.3. Pharmacokinetics

Comparative Bioavailability

The bioavailabilities of FTC and TAF were comparable when comparing ODEFSEY 200/25/25 mg to GENVOYA (EVG/COBI/FTC/TAF [150/150/200/10 mg] FDC tablet) following single-dose administration to healthy subjects under moderate fat fed conditions (N = 95) (see **CLINICAL TRIALS, Pivotal Comparative Bioavailability Study**).

The bioavailability of RPV was comparable when comparing ODEFSEY 200/25/25 mg to Edurant (RPV) 25 mg following single-dose administration to healthy subjects under moderate fat fed conditions (N = 95) (see **CLINICAL TRIALS, Pivotal Comparative Bioavailability Study**).

Absorption and Bioavailability

The multiple dose pharmacokinetic parameters of FTC, RPV and TAF and its metabolite tenofovir are provided in Table 13. Following oral administration in adult patients, peak plasma concentrations were observed 3 hours post-dose for FTC and 1 hour post-dose for TAF. Exposure to RPV was generally lower in HIV-1-infected patients than in healthy subjects. After oral administration, the C_{max} of RPV is achieved within 4–5 hours. The absolute bioavailability of FTC, RPV, and TAF are unknown.

Table 13. Multiple Dose Pharmacokinetic Parameters of FTC, RPV, TAF and its Metabolite Tenofovir Following Oral Administration with Food in HIV-Infected Adults

Parameter	Emtricitabine ^a Mean (CV%)	Rilpivirine ^b Mean (CV%)	Tenofovir Alafenamide ^c Mean (CV%)	Tenofovir ^{d,e} Mean (CV%)
C _{max} (microgram/mL)	2.1 (20.2)	ND	0.16 (51.1)	0.02 (26.1)
AUC ₀₋₂₄ (microgram•hour/mL)	11.7 (16.6)	2.2 (38.1)	0.21 (71.8)	0.29 (27.4)

C _{trough} (microgram/mL)	0.10 (46.7)	0.08 (44.3)	NA	0.01 (28.5)
---------------------------------------	-------------	-------------	----	-------------

CV = Coefficient of Variation; NA = Not Applicable; ND = Not Determined

- From Intensive PK analysis in Study 102, N=19
- From Population PK analysis in studies (C209 and C215) conducted in treatment-naïve adults with HIV-1 infection treated with RPV, N=679.
- From Population PK analysis in studies (104 and 111) conducted in EVG+COB+FTC+TAF, N=539.
- From Population PK analysis in studies (104 and 111) conducted in EVG+COB+FTC+TAF, N=841.
- In Studies 104 and 111, a 10 mg oral dose of TAF in GENVOYA resulted in greater than 90% lower concentrations of tenofovir in plasma as compared to a 300 mg oral dose of TDF in STRIBILD.

Effect of Food on Absorption

Relative to fasting conditions, the administration of ODEFSEY to healthy adult subjects with a moderate fat meal (~600 kcal, 27% fat) or high fat meal (~800-1000 kcal, 50% fat) resulted in a decrease in FTC systemic exposure (AUC) by 9 and 12%, respectively, and a decrease in C_{max} of 24% and 26%, respectively. The median T_{max} was delayed by 1 hour when ODEFSEY was administered with a meal. The decrease in FTC systemic exposure when ODEFSEY was administered with food is not considered significant.

Relative to fasting conditions, the administration of ODEFSEY to healthy adult subjects with a moderate fat meal (~600 kcal, 27% fat) or high fat meal (~800-1000 kcal, 50% fat) resulted in increased RPV systemic exposure (AUC) by 19% and 82%, respectively, and an increase in C_{max} of 42% and 111%, respectively. The median T_{max} was delayed by 1.0 hour under fed conditions.

Relative to fasting conditions, the administration of ODEFSEY to healthy adult subjects with a moderate fat meal (~600 kcal, 27% fat) or high fat meal (~800-1000 kcal, 50% fat) resulted in increased TAF systemic exposure (AUC) by 45% and 53%, respectively. The C_{max} values were not comparable under fasting and fed conditions and the median T_{max} was delayed approximately 1.0 hour under fed conditions.

As a result of the decrease in systemic exposure (AUC) and C_{max} of RPV when ODEFSEY is administered under fasting conditions, it is recommended that ODEFSEY be taken with a meal to obtain optimal absorption (see **DOSAGE AND ADMINISTRATION, Dosing Considerations**).

Distribution

Emtricitabine

In vitro binding of FTC to human plasma proteins is < 4% and is independent of concentration over the range of 0.02 to 200 µg/mL. At peak plasma concentration, the mean plasma to blood drug concentration ratio was ~1.0 and the mean semen to plasma drug concentration ratio was ~4.0.

Rilpivirine

Rilpivirine is approximately 99.7% bound to plasma proteins *in vitro*, primarily to albumin. The distribution of RPV into compartments other than plasma (e.g., cerebrospinal fluid, genital tract secretions) has not been evaluated in humans.

Tenofovir Alafenamide

The binding of tenofovir to human plasma proteins is < 0.7% and is independent of concentration over the range of 0.01 to 25 µg/mL. The binding of TAF to human plasma proteins in samples collected during clinical studies was approximately 80%.

Distribution studies in dogs showed 5.7 to 15-fold higher [¹⁴C]-radioactivity in lymphoid tissues (iliac, axillary, inguinal and mesenteric lymph nodes, and spleen) 24 hours following administration of an equivalent dose of [¹⁴C]-TAF relative to [¹⁴C]-TDF.

Metabolism

Emtricitabine

Emtricitabine is not significantly metabolized.

In vitro studies indicate that FTC is not an inhibitor of human CYP450 enzymes. Following administration of [¹⁴C]-FTC, complete recovery of the FTC dose was achieved in urine (~86%) and feces (~14%). Thirteen percent of the dose was recovered in the urine as three putative metabolites. The biotransformation of FTC includes oxidation of the thiol moiety to form the 3'-sulfoxide diastereomers (~9% of dose) and conjugation with glucuronic acid to form 2'-O-glucuronide (~4% of dose). No other metabolites were identifiable.

Rilpivirine

In vitro experiments indicate that RPV primarily undergoes oxidative metabolism mediated by the cytochrome P450 (CYP) 3A system.

Tenofovir Alafenamide

Metabolism is a major elimination pathway for tenofovir alafenamide in humans, accounting for > 80% of an oral dose. *In vitro* studies have shown that TAF is metabolized to tenofovir (major metabolite) by cathepsin A in PBMCs (including lymphocytes and other HIV target cells) and macrophages; and by carboxylesterase-1 in hepatocytes. Tenofovir alafenamide is a substrate of P-gp and BCRP transporters, and is minimally metabolized by CYP3A4. Upon coadministration with the moderate CYP3A inducer probe EFV, TAF exposure was unaffected.

In vivo, TAF is hydrolyzed within cells to form tenofovir (major metabolite), which is phosphorylated to the active metabolite, tenofovir diphosphate. In human clinical

studies, a 10 mg oral dose of TAF resulted in tenofovir diphosphate concentrations > 4-fold higher in PBMCs and > 90% lower concentrations of tenofovir in plasma as compared to a 300 mg oral dose of TDF.

In vitro, TAF is not an inhibitor of CYP1A2, CYP2B6, CYP2C8, CYP2C9, CYP2C19, or CYP2D6. TAF is not an inhibitor or inducer of CYP3A *in vivo*.

Excretion

Emtricitabine

The plasma half-life of FTC was approximately 10 hours. Following FTC dosing, the steady state mean intracellular half-life of FTC 5'-triphosphate (the active drug moiety) in PBMCs was 39 hours. Emtricitabine is primarily excreted in the urine by a combination of glomerular filtration and active tubular secretion.

Rilpivirine

The terminal elimination half-life of RPV is approximately 45 hours. After single dose oral administration of [¹⁴C]-rilpivirine, on average 85% and 6.1% of the radioactivity could be retrieved in feces and urine, respectively. In feces, unchanged RPV accounted for on average 25% of the administered dose. Only trace amounts of unchanged RPV (< 1% of dose) were detected in urine.

Tenofovir Alafenamide

Tenofovir alafenamide is eliminated following metabolism to tenofovir. Tenofovir is eliminated from the body in the feces and urine by both glomerular filtration and active tubular secretion. Tenofovir alafenamide and tenofovir have a median plasma half-life of 0.51 and 32.37 hours, respectively. Renal excretion of intact tenofovir alafenamide is a minor pathway with < 1% of the dose eliminated in urine. The pharmacologically active metabolite, tenofovir diphosphate, has a half-life of 150-180 hours within PBMCs.

Linearity/Non-linearity

Emtricitabine

The multiple dose pharmacokinetics of FTC are dose proportional over the dose range of 25 mg to 200 mg.

Tenofovir Alafenamide

TAF exposures are dose proportional over the dose range of 8 mg to 125 mg.

Special Populations and Conditions

Pediatrics (< 18 years of age)

ODEFSEY is not indicated for use in pediatric patients <18 years of age.

Geriatrics (≥ 65 years of age)

Clinical studies of RPV did not include sufficient numbers of patients aged 65 and over to determine whether they respond differently from adult patients < 65 years of age. Population pharmacokinetics analysis of HIV-infected patients in Phase II and Phase III trials of FTC+TAF given with EVG+COBI as a FDC tablet showed that within the age range of 12 to 82 years, age did not have a clinically relevant effect on exposures of TAF. ODEFSEY should be used with caution in this population.

Race

Emtricitabine

No pharmacokinetic differences due to race have been identified following the administration of FTC.

Rilpivirine and Tenofovir Alafenamide

Population pharmacokinetic analysis in HIV-1-infected patients indicated that race had no clinically relevant effect on the exposure to RPV or TAF.

Gender

No clinically relevant pharmacokinetic differences have been observed between men and women for FTC, RPV and TAF.

Hepatic Impairment

Emtricitabine

The pharmacokinetics of FTC has not been studied in patients with hepatic impairment; however, FTC is not significantly metabolized by liver enzymes, so the impact of liver impairment should be limited.

Rilpivirine

RPV is primarily metabolized and eliminated by the liver. In a study comparing 8 patients with mild hepatic impairment (Child-Pugh score A) to 8 matched controls and 8 patients with moderate hepatic impairment (Child-Pugh score B) to 8 matched controls, the multiple dose exposure of RPV was 47% higher in subjects with mild hepatic impairment and 5% higher in subjects with moderate hepatic impairment. No RPV dose adjustment is required in patients with mild or moderate hepatic impairment. RPV has not been studied in patients with severe hepatic impairment (Child Pugh score C).

Tenofovir Alafenamide

Clinically relevant changes in the pharmacokinetics of TAF or its metabolite tenofovir were not observed in patients with mild, moderate, or severe hepatic impairment; no TAF dose adjustment is required in patients with hepatic impairment.

Renal Impairment

Emtricitabine

FTC is principally eliminated by renal excretion, and the exposure to FTC increases in patients with renal impairment.

Rilpivirine

Population pharmacokinetic analysis indicated that RPV exposure was similar in HIV-1 infected subjects with mild renal impairment relative to HIV-1 infected subjects with normal renal function. There is limited or no information regarding the pharmacokinetics of RPV in patients with moderate or severe renal impairment or in patients with end-stage renal disease, and RPV concentrations may be increased due to alteration of drug absorption, distribution, and metabolism secondary to renal dysfunction. The potential impact is not expected to be of clinical relevance for HIV-1-infected patients with moderate renal impairment, and no dose adjustment is required in these patients. RPV should be used with caution and with increased monitoring for adverse effects in patients with severe renal impairment or end-stage renal disease. As RPV is highly bound to plasma proteins, it is unlikely that it will be significantly removed by hemodialysis or peritoneal dialysis (see **WARNINGS AND PRECAUTIONS, Special Populations**).

Tenofovir Alafenamide

No clinically relevant differences in TAF or tenofovir pharmacokinetics were observed between healthy subjects and subjects with severe renal impairment (estimated creatinine clearance < 30 mL/minute) in studies of TAF. There are no pharmacokinetic data on TAF in patients with creatinine clearance < 15 mL/minute.

Hepatitis B and/or Hepatitis C Virus Coinfection

Pharmacokinetics of FTC and TAF have not been fully evaluated in patients coinfecting with hepatitis B and/or C virus. Population pharmacokinetic analysis indicated that hepatitis B and/or C virus coinfection had no clinically relevant effect on the exposure to RPV.

Pregnancy and Postpartum

The exposure to total RPV after intake of RPV 25 mg once daily as part of an antiretroviral regimen was lower during pregnancy (similar for the 2nd and 3rd trimesters)

compared with postpartum (see Table 14). The decrease in unbound (i.e., active) RPV pharmacokinetic parameters during pregnancy compared to postpartum was less pronounced than for total RPV.

In women receiving RPV 25 mg once daily during the 2nd trimester of pregnancy, mean intra-individual values for total RPV C_{max} , AUC_{24h} , and C_{min} values were, respectively, 21%, 29%, and 35% lower as compared to postpartum; during the 3rd trimester of pregnancy, C_{max} , AUC_{24h} , and C_{min} values were, respectively, 20%, 31%, and 42% lower as compared to postpartum.

Table 14. Pharmacokinetic Results of Total RPV After Administration of RPV 25 mg Once Daily as Part of an Antiretroviral Regimen, During the 2nd Trimester of Pregnancy, the 3rd Trimester of Pregnancy, and Postpartum

Pharmacokinetics of Total RPV (mean ± SD, t_{max}:median [range])	Postpartum (6-12 Weeks) (n=11)	2nd Trimester of Pregnancy (n=15)	3rd Trimester of Pregnancy (n=13)
C_{min} , ng/mL	84.0 ± 58.8	54.3 ± 25.8	52.9 ± 24.4
C_{max} , ng/mL	167 ± 101	121 ± 45.9	123 ± 47.5
t_{max} , h	4.00 (2.03-25.08)	4.00 (1.00-9.00)	4.00 (2.00-24.93)
AUC_{24h} , ng.h/mL	2714 ± 1535	1792 ± 711	1762 ± 662

11. STORAGE, STABILITY AND DISPOSAL

Store below 30 °C (86 °F).

- Keep container tightly closed.
- Dispense only in original container.
- Do not use if seal over bottle opening is broken or missing.

12. SPECIAL HANDLING INSTRUCTIONS

There are no special handling instructions.

PART II: SCIENTIFIC INFORMATION

13. PHARMACEUTICAL INFORMATION

ODEFSEY is a FDC, single tablet regimen containing FTC, RPV and TAF hemifumarate. Emtricitabine is a synthetic nucleoside analog of cytidine. Rilpivirine is a NNRTI. Tenofovir alafenamide, a nucleoside reverse transcriptase inhibitor (NRTI), is a prodrug of tenofovir converted *in vivo* to tenofovir, an acyclic nucleoside phosphanate (nucleotide) analog of adenosine 5'-monophosphate.

ODEFSEY tablets are for oral administration. Each tablet contains 200 mg of FTC, 25 mg of RPV (as 27.5 mg of RPV hydrochloride) and 25 mg of TAF (as 28.0 mg of TAF hemifumarate).

The tablets also include the following inactive ingredients: croscarmellose sodium, lactose monohydrate, magnesium stearate, microcrystalline cellulose, polysorbate 20 and povidone. The tablets are film-coated with a coating material containing polyvinyl alcohol, titanium dioxide, macrogol/polyethylene glycol, talc, and iron oxide black.

Emtricitabine

Drug Substance

Common Name: emtricitabine (USAN)

Chemical Name: 5-fluoro-1-(2R,5S)-[2-(hydroxymethyl)-1,3-oxathiolan-5-yl]cytosine

Empirical Formula: C₈H₁₀FN₃O₃S

Molecular Weight: 247.24

Structural Formula:

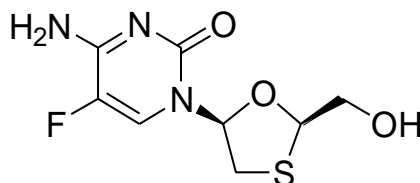

Physicochemical Properties:

Description: FTC is a white to off-white crystalline powder.

Solubility: The solubility is approximately 112 mg/mL in water at 25 °C. The partition coefficient (log P) is -0.43 and the pKa is 2.65.

Rilpivirine

Drug Substance

Common Name: rilpivirine hydrochloride (INN)

Chemical Name: 4-[[4-[[4-[(E)-2-cyanoethenyl]-2,6-dimethylphenyl]amino]-2-pyrimidinyl]amino]benzonitrile monohydrochloride

Empirical Formula: C₂₂H₁₈N₆•HCl

Molecular Weight: 402.88

Structural Formula:

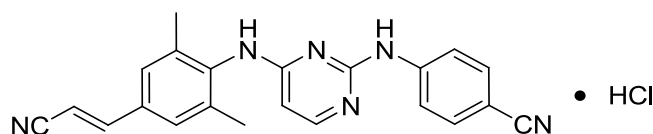

Physicochemical Properties:

Description: RPV hydrochloride is a white to almost white powder.

Solubility: RPV hydrochloride is practically insoluble in water over a wide pH range. The solubility is approximately 0.01 mg/mL in water at 25 °C.

Dissociation Constant: The pKa is 5.6 (pyrimidine moiety).

Partition Coefficient: The log P is 4.86.

Tenofovir alafenamide

Drug Substance

Common Name: Tenofovir alafenamide hemifumarate
Tenofovir alafenamide fumarate (USAN)

Chemical Name: Propan-2-yl N-[(S)-({[(2R)-1-(6-amino-9H-purin-9-yl)propan-2-yl]-oxy}methyl)(phenoxy)phosphoryl]-L-alaninate, (2E)-but-2-enedioate (2:1)

Empirical Formula: C₂₁H₂₉O₅N₆P•½(C₄H₄O₄)

Formula Weight: 534.50

Structural Formula:

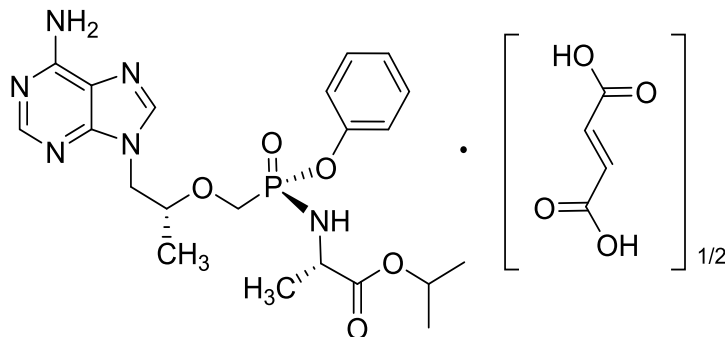

Physicochemical Properties:

Description: TAF hemifumarate is a white to off-white or tan powder.

Solubility: The solubility of TAF hemifumarate in water, pH 8.0 (50 mM phosphate buffer) at 20 °C is 4.86 mg/mL. The partition coefficient (log P) is 1.6 and the pKa is 3.96.

14. CLINICAL TRIALS

No data are available from clinical trials of ODEFSEY in HIV-infected patients. Clinical efficacy of ODEFSEY was established through linkage to studies conducted with FTC+TAF when given with COBI-boosted EVG as a FDC (GENVOYA [EVG/COBI/FTC/TAF]); and from studies of RPV when given with TRUVADA (FTC/TDF) as individual components or as a fixed-dose combination COMPLERA (FTC/RPV/TDF) by using comparative bioavailability data from healthy volunteers.

Pivotal Comparative Bioavailability Study

Study GS-US-366-1159 was a randomized, open-label, single-dose, three-way, six-sequence, crossover comparative bioavailability study under moderate fat fed conditions (approximately 600 kcal and 27% fat) conducted in 96 healthy male and female volunteers from 19 – 45 years of age. The study evaluated the comparative bioavailability of FTC, RPV and TAF from a FDC of ODEFSEY (FTC/RPV/TAF) 200/25/25 mg relative to GENVOYA (EVG/COBI/FTC/TAF) 150/150/200/10 mg FDC tablets or Edurant (RPV) 25 mg tablets administered in separate treatment arms. The bioavailability results from measured data in 95 subjects are provided in Table 15, Table 16, and Table 17.

The bioavailabilities of FTC and TAF were comparable when comparing ODEFSEY 200/25/25 mg to GENVOYA (EVG/COBI/FTC/TAF (150/150/200/10 mg) FDC tablet) following single-dose administration to healthy subjects (N = 95) under moderate fat fed conditions. The bioavailability of RPV was comparable when comparing ODEFSEY 200/25/25 mg to RPV 25 mg following single-dose administration to healthy subjects (N = 95) under moderate fat fed conditions.

Table 15. Summary Table of the Comparative Bioavailability Data for Study GS-US-366-1159

Emtricitabine (FTC)				
(1 x 200 mg)				
From measured data				
Geometric Mean				
Arithmetic Mean (CV %)				
Parameter	Test*	Reference†	% Ratio of Geometric Means	90% Confidence Interval
AUC _T (h•ng/mL)	9112.9 9381.9 (21.7)	9879.2 10159.4 (21.5)	92.24	90.84 – 93.67
AUC _{inf} (h•ng/mL)	9316.6 9603.2 (21.6)	10086.0 10387.1 (21.5)	92.37	90.93 – 93.83
C _{max} (ng/mL)	1534.6 1608.6 (26.5)	1522.2 1583.8 (23.8)	100.81	97.52 – 104.21
T _{max} § (h)	2.00 (0.75 – 5.00)	2.00 (0.75 – 5.00)		
T _{1/2} § (h)	18.71 (3.45 – 68.76)	18.90 (5.93 – 67.33)		

* ODEFSEY (FTC/RPV/TAF) 200 mg/25 mg/25 mg FDC tablets (Gilead Sciences Canada Inc.)

† GENVOYA (EVG/COBI/FTC/TAF) 150 mg/150 mg/200 mg/10 mg FDC tablets (Gilead Sciences Canada Inc.)

§ Expressed as median [range] only.

Table 16. Summary Table of the Comparative Bioavailability Data for Study GS-US-366-1159

Rilpivirine (RPV) (1 x 25 mg) From measured data				
Geometric Mean Arithmetic Mean (CV %)				
Parameter	Test*	Reference†	% Ratio of Geometric Means	90% Confidence Interval
AUC ₀₋₇₂ (h•ng/mL)	2351.07 2420.9 (24.8)	2099.24 2177.6 (27.8)	112.00	107.37 – 116.83
AUC _{inf} (h•ng/mL)	3635.88 3840.3 (36.4)	3275.76 3518.5 (43.1)	110.99	106.29 – 115.91
C _{max} (ng/mL)	118.35 122.0 (25.6)	103.85 108.3 (28.6)	113.96	108.81 – 119.36
T _{max} § (h)	4.00 (2.00 – 6.02)	4.00 (3.00 – 6.00)		
T _{1/2} § (h)	51.30 (23.19 – 126.37)	51.99 (5.01 – 129.90)		

* ODEFSEY (FTC/RPV/TAF) 200 mg/25 mg/25 mg FDC tablets (Gilead Sciences Canada Inc.)

† GENVOYA (EVG/COBI/FTC/TAF) 150 mg/150 mg/200 mg/10 mg FDC tablets (Gilead Sciences Canada Inc.)

§ Expressed as median [range] only.

Table 17. Summary Table of the Comparative Bioavailability Data for Study GS-US-366-1159

Tenofovir Alafenamide (TAF) (1 x 25 mg versus 1 x 10 mg)** From measured data				
Geometric Mean Arithmetic Mean (CV %)				
Parameter	Test*	Reference†	% Ratio of Geometric Means	90% Confidence Interval
AUC _T (h•ng/mL)	228.3 250.0 (43.4)	221.9 238.4 (36.5)	102.85	98.18 – 107.75
AUC _{inf} (h•ng/mL)	234.9 263.6 (42.0)	226.2 247.4 (36.1)	103.85	98.27 – 109.74
C _{max} (ng/mL)	178.0 198.0 (57.7)	176.6 191.5 (48.2)	100.78	91.63 – 110.85
T _{max} § (h)	1.50 (0.50 – 4.00)	1.50 (0.50 – 4.00)		
T _{1/2} § (h)	0.42 (0.29 – 0.91)	0.41 (0.31 – 0.87)		

* ODEFSEY (FTC/RPV/TAF) 200 mg/25 mg/25 mg FDC tablets (Gilead Sciences Canada Inc.)

† GENVOYA (EVG/COBI/FTC/TAF) 150 mg/150 mg/200 mg/10 mg FDC tablets (Gilead Sciences Canada Inc.)

§ Expressed as median [range] only.

**The amount of TAF in the ODEFSEY FDC tablet (25 mg) is adjusted compared with that in the GENVOYA FDC tablet (10 mg) as TAF is co-formulated with cobicistat in GENVOYA which increases the exposure of TAF.

14.1. Study Demographics and Trial Design

Treatment-Naïve HIV-1 Infected Patients

Emtricitabine+Tenofovir Alafenamide-Containing Regimens

In both Study 104 and Study 111, patients were randomized in a 1:1 ratio to receive either FTC+TAF (N = 866) once daily or FTC+TDF (N = 867) once daily, both given with EVG+COBI as a FDC tablet (administered as GENVOYA and STRIBILD, respectively).

For demographic and baseline characteristics for Study 104 and 111, see Table 18.

Table 18. Pooled Demographic and Baseline Characteristics of Antiretroviral Treatment-naïve HIV-1 Infected Adult Patients in Studies 104 and 111

	FTC+TAF (Administered as GENVOYA) (N = 866)	FTC+TDF (Administered as STRIBILD) (N = 867)
Demographic characteristics		
Median age, years (range)	33 (18-74)	35 (18-76)
Sex		
Male	733	740
Female	133	127
Race		
American Indian/ Alaska Native	5	8
White	485	498
Black	223	213
Native Hawaiian/ Pacific Islander	5	4
Asian	91	89
Other	57	55
Baseline disease characteristics		
Median baseline plasma HIV-1 RNA log ₁₀ copies/mL (range)	4.58 (2.57-6.89)	4.58 (1.28-6.98)
Percentage of patients with viral load ≤ 100,000 copies/mL	77.4	77.5
Percentage of patients with viral load > 100,000 to ≤ 400,000 copies/mL	17.0	17.8
Percentage of patients with viral load > 400,000 copies/mL	5.7	4.7
Median baseline CD4+ cell count /μL (range)	404 (0-1311)	406 (1-1360)
Percentage of patients with CD4+ cell counts < 200 cells/mm ³	13.0	13.5
HIV disease status		
Asymptomatic	779	800
Symptomatic HIV infection	53	34
AIDS	31	29

	FTC+TAF (Administered as GENVOYA) (N = 866)	FTC+TDF (Administered as STRIBILD) (N = 867)
Unknown	3	4
eGFR _{CG} (mL/min), median (Q1, Q3)	117.0 (99.6, 135.6)	113.9 (99.0, 133.6)
Proteinuria by urinalysis (dipstick)		
Grade 0	778	780
Grade 1	80	67
Grade 2	8	18
Grade 3	0	1
Missing-	0	1

Rilpivirine-Containing Regimens

The efficacy of RPV versus EFV in combination with FTC+TDF was evaluated in two Phase III, randomized, double-blind, double-dummy, active controlled international studies in antiretroviral treatment-naïve, HIV-1 infected patients (N = 1368).

The studies are identical in design with the exception of the background regimen (BR). Patients were randomized in a 1:1 ratio to receive either RPV 25 mg (N = 686) once daily or EFV 600 mg (N = 682) once daily in addition to a BR. In TMC278-C209 (N = 690), the BR was FTC/TDF. In TMC278-C215 (N = 678), the BR consisted of 2 NRTIs: FTC/TDF (60%, N = 406) or lamivudine/zidovudine (30%, N = 204) or abacavir plus lamivudine (10%, N = 68).

Patients with plasma HIV-1 RNA \geq 5000 copies/mL, who were screened for susceptibility to N(t)RTIs and for absence of specific NNRTI resistance-associated mutations, were included in the trials.

Demographic characteristics for patients who received FTC/TDF in Studies C209 and C215 are provided in Table 19.

Table 19. Demographic Characteristics of Antiretroviral Treatment-naïve HIV-1 Infected Adult Patients in Studies C209 (ECHO) and C215 (THRIVE)

	Treatment Arm RPV+FTC/TDF (N = 550)	Control Arm EFV+BR^{1,2} (N = 546)
Demographic characteristics		
Median age, years (range)	36.0 (18-78)	36.0 (19-69)
Sex		
Male	429	431
Female	121	115
Race		
White	348	334
Black	134	128
Asian	54	70
Other	5	7
Missing	9	7
Baseline disease characteristics		
Percentage of patients with viral load ≤ 100,000 copies/mL	52.4	46.9
Percentage of patients with viral load > 100,000 to ≤ 500,000 copies/mL	38.0	40.1
Percentage of patients with viral load > 500,000 copies/mL	9.6	13.0
Percentage of patients with CD4+ cell counts < 200 cells/μL	33.0 ³	30.0

1. In Study C209, the BR was FTC/TDF.
2. In Study C215, the BR consisted of 2 NRTIs: FTC/TDF or lamivudine/zidovudine or abacavir plus lamivudine. Only the results for FTC/TDF are presented here.
3. Excludes 1 patient with missing CD4+ cell count.

Virologically Suppressed HIV-1 Infected Patients

Emtricitabine+Tenofovir Alafenamide-Containing Regimens

In Study 109, the efficacy and safety of switching from either ATRIPLA (EFV/FTC/TDF), TRUVADA (FTC/TDF) plus atazanavir (boosted by either COBI or ritonavir), or STRIBILD to FTC+TAF given with EVG+COBI as a FDC tablet (administered as GENVOYA) were evaluated in a randomized, open-label study of virologically

suppressed (HIV-1 RNA < 50 copies/mL) HIV-1 infected adults (N = 1436). Patients must have been stably suppressed (HIV-1 RNA < 50 copies/mL) on their baseline regimen for at least 6 months and had no resistance mutations to FTC, TAF, or EVG prior to study entry. Patients were randomized in a 2:1 ratio to either switch to FTC+TAF given with EVG+COBI as a FDC tablet at baseline (N = 959), or stay on their baseline antiretroviral regimen (N = 477). Demographic and baseline characteristics are presented in Table 20.

Patients were stratified by prior treatment regimen. At screening, 42% of patients were receiving TRUVADA plus atazanavir (boosted by either COBI or ritonavir), 32% of patients were receiving STRIBILD, and 26% of patients were receiving ATRIPLA.

Table 20. Demographic and Baseline Characteristics of Virologically Suppressed HIV-1 Infected Adult Patients in Study 109

	Study GS-US-292-0109	
	FTC+TAF (Administered as GENVOYA) (N = 959)	Baseline Regimen (N = 477)
Demographic characteristics		
Median age, years (range)	41 (21-77)	40 (22-69)
Sex		
Male	856	427
Female	103	50
Race		
American Indian/ Alaska Native	5	2
White	651	314
Black	169	102
Native Hawaiian/ Pacific Islander	6	1
Asian	59	35
Other	67	22
Not permitted	2	1
Prior treatment regimen		
STB	306	153
ATR	251	125
ATV/boosted+TVD	402	199
Baseline disease characteristics		

	Study GS-US-292-0109	
	FTC+TAF (Administered as GENVOYA) (N = 959)	Baseline Regimen (N = 477)
HIV-1 RNA < 50 copies/mL	943	466
CD4 cell count (cells/μL), median (Q1, Q3)	675 (520, 833)	662 (525, 831)
eGFR _{CG} (mL/min), median (Q1, Q3)	105.7 (89.4, 126.0)	107.7 (88.7, 128.2)
Proteinuria by urinalysis (dipstick)		
Grade 0	873	430
Grade 1	81	44
Grade 2	4	3
Grade 3	0	0
-Missing-	1	0

STB: STRIBILD; ATR: ATRIPLA; ATZ: atazanavir; TVD: TRUVADA

Rilpivirine-Containing Regimens

The efficacy and safety of switching from a ritonavir-boosted protease inhibitor in combination with two NRTIs to COMPLERA (FTC/RPV/TDF) was evaluated in a randomized, open-label study of virologically-suppressed HIV-1 infected adults, Study GS-US-264-0106. Patients had to be on either their first or second antiretroviral regimen with no history of virologic failure, have no current or past history of resistance to any of the three components of COMPLERA, and must have been stably suppressed (HIV-1 RNA < 50 copies/mL) for at least 6 months prior to screening. Patients were randomized in a 2:1 ratio to either switch to COMPLERA at baseline (COMPLERA, N = 317), or stay on their baseline antiretroviral regimen for 24 weeks (Stay on Baseline Regimen, SBR, N = 159) before switching to COMPLERA for an additional 24 weeks (SBR Rollover to COMPLERA, N = 152).

Demographic characteristics for patients in Study GS-US-264-0106 are provided in Table 21.

Table 21. Demographic and Baseline Characteristics of Virologically-Suppressed HIV-1 Infected Adult Patients in GS-US-264-0106

	Study GS-US-264-0106		
	Total (N = 476)	Treatment Arm FTC/RPV/TDF (N = 317)	Stayed on Baseline Regimen (N = 159)
Demographic characteristics			
Median age, years (range)	42 (19-73)	42 (19-73)	43 (20-71)
Sex			
Male	417	273	144
Female	59	44	15
Race			
White	365	241	124
Black	83	61	22
Other	28	15	13
Prior treatment regimen			
TDF Containing Regimen	390	260	130
Non-TDF Containing Regimen	86	57	29
Baseline disease characteristics			
HIV-1 RNA <50 copies/mL	451	299	152
CD4+ cell count (cells/ μ L), median (Q1, Q3)	558 (409, 727)	554 (412, 713)	561 (401, 744)
eGFR _{CG} (mL/min), median (Q1, Q3)	104.1 (89.8, 123.7)	104.2 (90.0, 123.2)	103.8 (88.9, 124.3)

The mean baseline CD4 cell count was 584 cells/mm³ (range: 42-1484). Randomization was stratified by use of TDF and/or lopinavir/ritonavir in the baseline regimen.

HIV-1 Infected Patients with Renal Impairment

Emtricitabine+Tenofovir Alafenamide-Containing Regimens

In Study 112, the efficacy and safety of FTC+TAF were evaluated in an open-label clinical study in which 242 HIV-1 infected patients with mild to moderate renal impairment (eGFR by Cockcroft-Gault method between 30 to 69 mL/minute) switched to

FTC+TAF given with EVG+COBI as a FDC tablet (administered as GENVOYA).
 Patients were virologically suppressed (HIV-1 RNA < 50 copies/mL) for at least 6
 months before switching.

For demographic and baseline characteristics for Study 112, see Table 22.

Table 22. Demographic and Baseline Characteristics of Virologically Suppressed HIV-1 Infected Adult Patients with Renal Impairment in Study GS-US-292-0112

	Study GS-US-292-0112	
	Cohort 1: ART-Experienced	
	Baseline eGFR _{CG} < 50 mL/min (N = 80)	Baseline eGFR _{CG} ≥ 50 mL/min (N = 162)
Demographic characteristics		
Median age, years (range)	59 (31-82)	58 (24-76)
Sex		
Male	59	133
Female	21	29
Race		
American Indian/ Alaska Native	1	0
White	39	113
Black	14	30
Native Hawaiian/ Pacific Islander	0	2
Asian	23	11
Other	3	4
Not permitted	0	2
Baseline disease characteristics		
HIV-1 RNA categories (copies/mL)		
< 50	78	158
≥ 50 to ≤ 100,000	2	4
> 100,000 to ≤ 400,000	0	0
CD4 cell count (cells/uL), median (Q1, Q3)	622 (449, 844)	635 (461, 797)
HIV disease status		
Asymptomatic	46	134
Symptomatic HIV infection	18	10
AIDS	16	18
eGFR _{CG} ^b (mL/min), median (Q1, Q3)	42.6 (37.7, 45.7)	60.3 (55.5, 65.0)

	Study GS-US-292-0112	
	Cohort 1: ART-Experienced	
	Baseline eGFR _{CG} < 50 mL/min (N = 80)	Baseline eGFR _{CG} ≥ 50 mL/min (N = 162)
Proteinuria by urinalysis (dipstick)		
Grade 0	45	118
Grade 1	23	33
Grade 2	12	11
Grade 3	0	0

14.2. Study results

Treatment-Naïve HIV-1 Infected Patients

Emtricitabine+Tenofovir Alafenamide-Containing Regimens

In both Studies 104 and 111, patients were stratified by baseline HIV-1 RNA ($\leq 100,000$ copies/mL, $> 100,000$ copies/mL to $\leq 400,000$ copies/mL, or $> 400,000$ copies/mL), by CD4 count (< 50 cells/ μ L, 50-199 cells/ μ L, or ≥ 200 cells/ μ L), and by region (US or ex-US).

Treatment outcomes of Studies 104 and 111 through Week 48 and Week 96 are presented in Table 23.

Table 23. Pooled Virologic Outcomes of Studies 104 and 111 at Week 48^a and Week 96^b

	Week 48		Week 96	
	FTC+TAF (administered as GENVOYA) (N = 866)	FTC+TDF (administered as STRIBILD) (N = 867)	FTC+TAF (administered as GENVOYA) (N = 866)	FTC+TDF (administered as STRIBILD) (N = 867)
Virologic Success HIV-1 RNA < 50 copies/mL	92%	90%	87%	85%
Treatment Difference	2.0% (95% CI: -0.7% to 4.7%)		1.5% (95% CI: -1.8% to 4.8%)	
Virologic Failure HIV-1 RNA ≥ 50 copies/mL ^c	4%	4%	5%	4%
No Virologic Data at Week 48 or Week 96 Window	4%	6%	9%	11%
Discontinued Study Drug Due to AE or Death ^d	1%	2%	1%	2%

	Week 48		Week 96	
	FTC+TAF (administered as GENVOYA) (N = 866)	FTC+TDF (administered as STRIBILD) (N = 867)	FTC+TAF (administered as GENVOYA) (N = 866)	FTC+TDF (administered as STRIBILD) (N = 867)
Discontinued Study Drug Due to Other Reasons and Last Available HIV-1 RNA < 50 copies/mL ^e	2%	4%	6%	7%
Missing Data During Window but on Study Drug	1%	<1%	2%	1%
Proportion (%) of Patients with HIV-1 RNA < 50 copies/mL by Subgroup				
Age				
< 50 years	716/777 (92%)	680/753 (90%)	668/777 (86%)	639/753 (85%)
≥ 50 years	84/89 (94%)	104/114 (91%)	82/89 (92%)	100/114 (88%)
Sex				
Male	674/733 (92%)	673/740 (91%)	635/733 (87%)	631/740 (85%)
Female	126/133 (95%)	111/127 (87%)	115/133 (87%)	108/127 (85%)
Race				
Black	197/223 (88%)	177/213 (83%)	173/223 (78%)	168/213 (79%)
Nonblack	603/643 (94%)	607/654 (93%)	577/643 (90%)	571/654 (87%)
Baseline Viral Load				
≤ 100,000 copies/mL	629/670 (94%)	610/672 (91%)	587/670 (88%)	573/672 (85%)
> 100,000 copies/mL	171/196 (87%)	174/195 (89%)	163/196 (83%)	166/195 (85%)
Baseline CD4+ cell count				
< 200 cells/mm ³	96/112 (86%)	104/117 (89%)	93/112 (83%)	97/117 (83%)
≥ 200 cells/mm ³	703/753 (93%)	680/750 (91%)	657/753 (87%)	642/750 (86%)

- Week 48 window was between Day 294 and 377 (inclusive).
- Week 96 window was between Day 630 and 713 (inclusive).
- Included patients who had ≥ 50 copies/mL in the Week 48 or 96 window; patients who discontinued early due to lack or loss of efficacy; patients who discontinued for reasons other than an adverse event (AE), death or lack or loss of efficacy and at the time of discontinuation had a viral value of ≥ 50 copies/mL.
- Includes patients who discontinued due to AE or death at any time point from Day 1 through the time window if this resulted in no virologic data on treatment during the specified window.
- Includes patients who discontinued for reasons other than an AE, death or lack or loss of efficacy; e.g., withdrew consent, loss to follow-up, etc.

In Studies 104 and 111, FTC+TAF met the noninferiority criteria in achieving HIV-1 RNA < 50 copies/mL at Week 48 and Week 96 when compared to FTC+TDF, both given with EVG+COBI as a FDC tablet (administered as GENVOYA and STRIBILD, respectively). The 95% CIs for differences in virologic success between treatment groups included

zero for most subgroups evaluated suggesting no differences between the treatments. Treatment outcomes were consistent through Week 144.

In Studies 104 and 111, the mean increase from baseline in CD4+ cell count at Week 48, Week 96, and Week 144 was 230 cells/mm³, 280 cells/mm³ and 326 cells/mm³, respectively, in FTC+TAF-treated patients and 211 cells/mm³, 266 cells/mm³, and 305 cells/mm³ in FTC+TDF-treated patients (p = 0.024, p = 0.14, p = 0.06 at Week 48, Week 96, and Week 144, respectively).

Bone Mineral Density

In the pooled analysis of Studies 104 and 111, the effects of FTC+TAF compared to that of FTC+TDF on BMD from baseline to Week 48, Week 96, and Week 144 were assessed by dual-energy X-ray absorptiometry (DXA). As shown in Table 24, in patients who had both baseline and Week 48, Week 96, and Week 144 measurements (Week 48: N = 780 and 784 in the FTC+TAF group and N = 767 and 773 in the FTC+TDF group for hip and spine, respectively; Week 96: N = 716 and 722 in the FTC+TAF group and N = 711 and 714 in the FTC+TDF group, for hip and spine, respectively; Week 144: N = 690 and 702 in the FTC+TAF group and N = 683 and 686 in the FTC+TDF group, for hip and spine, respectively) there were smaller decreases in BMD in patients receiving FTC+TAF as compared to-patients receiving FTC+TDF, both given with EVG+COBI as a FDC tablet (GENVOYA and STRIBILD, respectively).

Table 24. Measures of Bone Mineral Density in Studies 104 and 111 (Week 48, Week 96, and Week 144 analyses)

	Week 48				Week 96				Week 144			
	FTC+TAF (administered as GENVOYA)	FTC+TDF (administered as STRIBILD)	Treatment Difference		FTC+TAF (administered as GENVOYA)	FTC+TDF (administered as STRIBILD)	Treatment Difference		FTC+TAF (administered as GENVOYA)	FTC+TDF (administered as STRIBILD)	Treatment Difference	
Hip DXA Analysis	N = 780	N = 767	Difference in LSM (95% CI)	P- value	N = 716	N = 711	Difference in LSM (95% CI)	P- value	N=690	N=683	Difference in LSM (95% CI)	P- value
Mean (SD) Percent Change in BMD	-0.7% (3.3%)	-3.0% (3.4%)	2.3% (2.0 to 2.6)	p < 0.001	-0.7% (3.9%)	-3.3% (4.0%)	2.6% (2.2 to 3.0)	p < 0.001	-0.8% (4.4%)	-3.4% (4.3%)	2.6% (2.2 to 3.1)	p < 0.001
Patients with Categorical Change:												
> 3% Decrease in BMD	17%	50%	—	—	23%	56%	—	—	28%	55%	--	--
> 3% Increase in BMD	7%	3%			12%	6%			13%	6%		
Patients with No Decrease (≥ zero % change) in BMD	35%	14%	—	—	39%	16%	—	—	40%	19%	--	--
Lumbar Spine DXA Analysis	N = 784	N = 773			N = 722	N = 714			N=702	N=686		
Mean (SD) Percent Change in BMD	-1.3% (3.1%)	-2.9% (3.2%)	1.6% (1.2 to 1.9)	p < 0.001	-1.0% (3.7%)	-2.8% (3.9%)	1.8% (1.4 to 2.2)	p < 0.001	-0.9% (4.1%)	-3.0% (4.3%)	2.0% (1.6 to 2.5)	p < 0.001

ODEFSEY (emtricitabine/rilpivirine*/tenofovir alafenamide**) tablets
 *as rilpivirine hydrochloride **as tenofovir alafenamide hemifumarate
 Product Monograph

	Week 48				Week 96				Week 144			
	FTC+TAF (administered as GENVOYA)	FTC+TDF (administered as STRIBILD)	Treatment Difference		FTC+TAF (administered as GENVOYA)	FTC+TDF (administered as STRIBILD)	Treatment Difference		FTC+TAF (administered as GENVOYA)	FTC+TDF (administered as STRIBILD)	Treatment Difference	
Patients with Categorical Change: > 3% Decrease in BMD > 3% Increase in BMD	27% 7%	46% 3%	—	—	26% 11%	48% 6%	—	—	30% 13%	49% 7%	--	--
Patients with No Decrease (≥ zero % change) in BMD	34%	17%	—	—	37%	21%	—	—	39%	22%	--	--

Changes in Renal Laboratory Tests and Renal Safety

In the pooled analysis of Studies 104 and 111 in treatment-naïve adult patients, there were statistically significantly higher increases in serum creatinine, Urine Protein to Creatinine Ratio (UPCR), Urine Albumin to Creatinine Ratio (UACR), urine retinol binding protein (RBP) to creatinine ratio, and urine beta-2-microglobulin to creatinine ratio in the FTC+TDF group as compared to the FTC+TAF group (see Table 25). There were zero cases of Fanconi syndrome or Proximal Renal Tubulopathy (PRT) in the FTC+TAF group through Week 144.

Table 25. Change from Baseline in Renal Laboratory Tests in Studies 104 and 111 (Week 48, Week 96, and Week 144 analyses)

	Week 48			Week 96			Week 144		
	FTC+TAF (administered as GENVOYA) (N = 866)	FTC+TDF (administered as STRIBILD) (N = 867)	Treatment Difference	FTC+TAF (administered as GENVOYA) (N = 866)	FTC+TDF (administered as STRIBILD) (N = 867)	Treatment Difference	FTC+TAF (administered as GENVOYA) (N = 866)	FTC+TDF (administered as STRIBILD) (N = 867)	Treatment Difference
Serum Creatinine ($\mu\text{mol/L}$) ^a	7.07 \pm 10.96	9.72 \pm 19.18	-3.54 p < 0.001	3.54 \pm 10.08	6.19 \pm 11.23	-2.65 p < 0.001	3.54 \pm 10.61	6.19 \pm 11.23	-3.54 p < 0.001
Proteinuria by Urine Dipstick ^b	31%	37%	p = 0.022	36%	41%	p = 0.034	40%	45%	p = 0.027
Urine Protein to Creatinine Ratio [UPCR] ^c	-3.4%	19.8%	p < 0.001	-9.1%	16.2%	p < 0.001	-10.5%	25.2%	p < 0.001
Urine Albumin to Creatinine Ratio [UACR] ^c	-4.7%	7.1%	p < 0.001	-5.2%	4.9%	p < 0.001	- ^d	- ^d	- ^d
Urine Retinol Binding Protein to Creatinine Ratio ^c	9.2%	51.2%	p < 0.001	13.8%	74.2%	p < 0.001	34.8%	111%	p < 0.001
Urine Beta-2-Microglobulin to Creatinine Ratio ^c	-31.7%	24.1%	p < 0.001	-32.1%	33.5%	p < 0.001	-25.7%	53.8%	p < 0.001

- a. Mean change \pm SD
- b. Includes all severity grades (1-3)
- c. Median percent change
- d. UACR was assessed up to Week 96.

At Week 48, 96, and 144, the proportion of patients with any grade hypophosphatemia was 3.6%, 5.6%, and 6.8% in patients receiving FTC+TAF and 4.0%, 5.4%, and 7.6% in patients receiving FTC+TDF, respectively. The median (Q1, Q3) change from baseline in FEPO₄ was 2.0% (-1.2%, 5.6%), 2.1% (-1.3%, 5.5%), and 3.0% (-0.7%, 7.2%) at Weeks 48, 96, and 144, respectively, in patients receiving FTC+TAF and 2.6% (-0.7%, 6.4%), 2.7% (-0.8%, 7.0%), and 4.1% (0.2%, 8.0%) at Weeks 48, 96, and 144, respectively, in patients receiving FTC+TDF (p = 0.006, 0.009, and 0.001 at Week 48, Week 96, and Week 144, respectively).

The median (Q1, Q3) change from baseline in the ratio of the renal tubular maximum reabsorption rate of phosphate to the glomerular filtration rate (TmP/GFR) was -0.2 mg/dL (-0.7 mg/dL, 0.2 mg/dL), -0.3 mg/dL (-0.9 mg/dL, 0.2 mg/dL), and -0.4 mg/dL (-1.0 mg/dL, 0.1 mg/dL) at Weeks 48, 96, and 144, respectively, in patients receiving FTC+TAF and -0.3 mg/dL (-0.7 mg/dL, 0.2 mg/dL), -0.4 mg/dL (-0.8 mg/dL, 0.1 mg/dL), and -0.5 mg/dL (-1.0 mg/dL, 1.0 mg/dL) at Weeks 48, 96, and 144, respectively, in patients receiving FTC+TDF (p = 0.21, 0.35, and 0.011 at Week 48, Week 96, and Week 144, respectively).

Changes in Lipid Laboratory Tests

Increases from baseline were observed in both treatment groups for the fasting lipid parameters total cholesterol, direct LDL, HDL, and triglycerides at Week 48, 96, and 144. As seen in Table 6, the median increase from baseline for these parameters was greater in patients receiving FTC+TAF compared with patients receiving FTC+TDF, both given with EVG+COBI as a FDC tablet (administered as GENVOYA and STRIBILD, respectively) (p < 0.001 for the difference between treatment groups for fasting total cholesterol, direct LDL, HDL, and triglycerides). Median (Q1, Q3) change from baseline at Weeks 48, 96, and 144 in total cholesterol to HDL ratio was 0.1 (-0.3, 0.5), 0.1 (-0.3, 0.7), and 0.2 (-0.3, 0.7) in patients receiving FTC+TAF and 0.0 (-0.5, 0.4), 0.0 (-0.4, 0.5), and 0.1 (-0.4, 0.6) in patients receiving FTC+TDF (p < 0.001 for the difference between treatment groups at Weeks 48 and 96; p = 0.006 at Week 144), respectively (see **ADVERSE REACTIONS**).

Rilpivirine-Containing Regimens

In studies C209 and C215, efficacy at Week 48 and Week 96 for patients in the RPV and EFV arms for the pooled data are shown in Table 26. Similar efficacy for Edurant was seen in each trial demonstrating non-inferiority to comparator. The response rate (confirmed undetectable viral load HIV-1 RNA < 50 copies/mL) at Week 96 was comparable between the RPV arm and the EFV arm. The incidence of virologic failure was higher in the RPV arm than the EFV arm at Week 96; however, most of the virologic failures occurred within the first 48 weeks of treatment.

Table 26. Pooled Virologic Outcomes of Randomized Treatment of Studies C209 and C215 (for Patients Receiving RPV or EFV in Combination with FTC/TDF) at Week 48 and Week 96^a

	Outcome at Week 48		Outcome at Week 96	
	RPV + FTC/TDF	EFV + FTC/TDF	RPV + FTC/TDF	EFV + FTC/TDF
	(N = 550)	(N = 546)	(N = 550)	(N = 546)
Virologic Success				
Confirmed Undetectable Viral Load (< 50 HIV-1 RNA copies/ml) ^{a,b}	459 (83.5%)	450 (82.4%)	423 (76.9%)	422 (77.3%)
Virologic failure ^c	52 (9.5%)	23 (4.2%)	63 (11.5%)	28 (5.1%)
Death	0	1 (0.2%)	0	4 (0.7%)
Discontinued study due to adverse event (AE)	12 (2.2%)	39 (7.1%)	20 (3.6%)	44 (8.1%)
Discontinued study for other reasons	27 (4.9%)	33 (6.0%)	44 (8.0%)	48 (8.8%)

N = number of patients per treatment group

- a Patient with 2 consecutive viral load values <50 copies/mL (ITT TLOVR - Intention to Treat Time to Loss of Virologic Response).
- b The difference of response rate is -3% to 6% (95% confidence interval) for week 48 and -5% to 5% for week 96, respectively, using normal approximation.
- c Includes patients who were rebounder (confirmed viral load ≥ 50 copies/mL after being responder) or who were never suppressed (no confirmed viral load < 50 copies/mL).

Virologic response by baseline plasma viral load is presented in Table 27.

Table 27. Virological Outcomes of Studies C209 and C215 (Pooled Data for Patients Receiving Rilpivirine or Efavirenz in Combination with Emtricitabine/Tenofovir DF) at 48 Weeks and 96 weeks by Baseline Viral Load and Baseline CD4+ Cell Count

	Outcome at Week 48*		Outcome at Week 96*	
	RPV + FTC/TDF	EFV + FTC/TDF	RPV + FTC/TDF	EFV + FTC/TDF
Virologic Response	459/550 (83.5%)	450/546 (82.4%)	423/550 (76.9%)	422/546 (77.3%)
By baseline viral load (copies/mL)				
≤ 100,000	258/288 (89.6%)	217/256 (84.8%)	241/288 (83.7%)	206/255 (80.8%)
> 100,000	201/262 (76.7%)	233/290 (80.3%)	182/262 (69.5%)	216/291 (74.2%)
By baseline CD4+ cell count (cells/mm ³)				

	Outcome at Week 48*		Outcome at Week 96*	
	RPV + FTC/TDF	EFV + FTC/TDF	RPV + FTC/TDF	EFV + FTC/TDF
< 200	138/181 (76.2%)	132/164 (80.5%)	122/181 (67.4%)	119/164 (72.6%)
≥ 200	321/368 (87.2%)	318/382 (83.2%)	301/368 (81.8%)	303/382 (79.3%)
Virologic Failure ^a	52/550 (9.5%)	23/546 (4.2%)	63/550 (11.5%)	28/546 (5.1%)
By baseline viral load (copies/mL)				
≤ 100,000	12/288 (4.2%)	6/256 (2.3%)	17/288 (5.9%)	6/255 (2.4%)
> 100,000	40/262 (15.3%)	17/290 (5.9%)	46/262 (17.6%)	22/291 (7.6%)
By baseline CD4+ cell count (cells/mm ³)				
< 200	28/181 (15.5%)	12/164 (7.3%)	36/181 (19.9%)	14/164 (8.5%)
≥ 200	24/368 (6.5%)	11/382 (2.9%)	27/368 (7.3%)	14/382 (3.7%)

N = number of patients per treatment group

* Imputations according to the TLOVR algorithm

a Includes patients who were rebounder (confirmed viral load ≥ 50 copies/mL after being responder) or who were never suppressed (no confirmed viral load < 50 copies/mL).

Virologic outcomes were comparable between males and females in studies C209 and C215.

Based on the pooled data from the C209 and C215 trials at 96 weeks of treatment, the mean CD4+ cell count increase from baseline was 226 cells/mm³ for RPV plus FTC/TDF-treated patients and 222 cells/mm³ for EFV plus FTC/TDF-treated patients [estimated treatment difference (95% CI): +8 (-13 to 28)].

Changes in Lipid Laboratory Tests

In Studies C209 and C215, changes from baseline in total cholesterol, LDL-cholesterol, HDL-cholesterol and triglycerides are presented in the **ADVERSE REACTIONS** section. The mean changes from baseline were smaller in the RPV arm versus the EFV arm. The impact of such findings has not been demonstrated.

Virologically Suppressed HIV-1 Infected Patients

Emtricitabine+Tenofovir Alafenamide-Containing Regimens

Treatment outcomes of Study 109 through Week 48 and Week 96 are presented in Table 28.

Table 28. Virologic Outcomes of Study 109 at Week 48^a and Week 96^b

	Week 48		Week 96	
	FTC+TAF (administered as GENVOYA) (N = 959)	Baseline Regimen (N = 477)	FTC+TAF (administered as GENVOYA) (N = 959)	Baseline Regimen (N = 477)
Virologic Success HIV-1 RNA < 50 copies/mL	97%	93%	93%	89%
Treatment Difference	4.1% (95% CI: 1.6% to 6.7%)		3.7% (95% CI: 0.4% to 7.0%)	
p-value	p < 0.001		p = 0.017	
Virologic Failure HIV-1 RNA ≥ 50 copies/mL^c	1%	1%	2%	2%
No Virologic Data at Week 48 or 96 Window	2%	6%	5%	9%
Discontinued Study Drug Due to AE or Death ^d	1%	1%	1%	3%
Discontinued Study Drug Due to Other Reasons and Last Available HIV-1 RNA < 50 copies/mL ^e	1%	4%	3%	6%
Missing Data During Window but on Study Drug	0	<1%	1%	<1%

- Week 48 window was between Day 294 and 377 (inclusive).
- Week 96 window was between Day 630 and 713 (inclusive).
- Included patients who had ≥ 50 copies/mL in the Week 48 or Week 96 window; patients who discontinued early due to lack or loss of efficacy; patients who discontinued for reasons other than an adverse event (AE), death or lack or loss of efficacy and at the time of discontinuation had a viral value of ≥ 50 copies/mL.
- Includes patients who discontinued due to AE or death at any time point from Day 1 through the time window if this resulted in no virologic data on treatment during the specified window.
- Includes patients who discontinued for reasons other than an AE, death or lack or loss of efficacy; e.g., withdrew consent, loss to follow-up, etc.

Switching to FTC+TAF when given with EVG+COBI as a FDC tablet (administered as GENVOYA) was non-inferior at Week 48 (p < 0.001) and at Week 96 (p = 0.017) in maintaining HIV-1 RNA < 50 copies/mL when compared to patients who stayed on their baseline regimen.

The mean increase from baseline in CD4+ cell count at Week 48 and Week 96 was 35 and 60 cells/mm³ in FTC+TAF-treated patients and 24 and 42 cells/mm³ in patients who stayed on their baseline regimen, respectively.

Bone Mineral Density

Changes in BMD from baseline to Week 48 were assessed by DXA in patients who had both baseline and Week 48 measurements (N = 869 and N = 881 in FTC+TAF arm, and N = 428 and N = 436 in patients who remained on their baseline regimen, for hip and

spine, respectively). Changes in BMD from baseline to Week 96 were assessed by DXA in patients who had both baseline and Week 96 measurements (N = 809 and N = 821 in the FTC+TAF arm, and N = 396 and N = 401 in patients who remained on their baseline regimen, for hip and spine, respectively). Results for Week 48 and Week 96 are summarized in Table 29.

ODEFSEY (emtricitabine/rilpivirine*/tenofovir alafenamide**) tablets
 *as rilpivirine hydrochloride **as tenofovir alafenamide hemifumarate
 Product Monograph

Table 29. Measures of Bone Mineral Density in Study 109 (Week 48 and Week 96 analyses)

	Week 48				Week 96			
	FTC+TAF (administered as GENVOYA)	Baseline Regimen	Treatment Difference		FTC+TAF (administered as GENVOYA)	Baseline Regimen	Treatment Difference	
Hip DXA Analysis	N = 869	N = 428	Difference in LSM (95% CI)	P-value	N=809	N=396	Difference in LSM (95% CI)	P-value
Mean (SD) Percent Change in BMD	1.5% (2.7%)	-0.3% (2.8%)	1.8% (1.5 to 2.1)	p < 0.001	2.4% (3.6%)	-0.5% (3.4%)	2.9% (2.5 to 3.3)	p < 0.001
Patients with Categorical Change:								—
> 3% Decrease in BMD	3%	13%	—	—	2%	15%	—	
> 3% Increase in BMD	21%	7%			35%	9%		
Patients with No Decrease (≥ zero% change) in BMD	78%	46%	—	—	82%	43%	—	—
Lumbar Spine DXA Analysis	N = 881	N = 436			N=821	N=401		
Mean (SD) Percent Change in BMD	1.6% (3.8%)	-0.4% (4.1%)	2.0% (1.5 to 2.4)	p < 0.001	2.1% (3.8%)	-0.1% (3.5%)	2.2% (1.8 to 2.6)	p < 0.001
Patients with Categorical Change:								
> 3% Decrease in BMD	8%	19%	—	—	6%	17%	—	—
> 3% Increase in BMD	33%	13%			37%	18%		
Patients with No Decrease (≥ zero% change) in BMD	74%	47%	—	—	75%	47%	—	—

Changes in Renal Laboratory Tests and Renal Safety

There were decreases from baseline in proteinuria (UPCR), albuminuria (UACR), and tubular proteinuria (urine RBP to creatinine ratio and urine beta-2-microglobulin to creatinine ratio), and also in other measures of proximal renal tubular dysfunction (including fractional excretion of uric acid [FEUA]) in patients receiving FTC+TAF when given with EVG+COBI as a FDC tablet (administered as GENVOYA), as compared with increases from baseline in patients who stayed on their TDF-containing baseline regimen, collectively indicating a reduced impact of TAF on proximal renal tubular function. At Week 96, the median percentage change in UPCR was -26% vs. 9%; in UACR it was -14% vs. 11%. At Week 48, the median percentage change in urine RBP to creatinine ratio was -33% vs. 18%; and in urine beta-2-microglobulin to creatinine ratio it was -52% vs. 19% ($p < 0.001$ for all comparisons). There were zero cases of Fanconi syndrome or PRT in patients switching to FTC + TAF when given with EVG+COBI as a FDC tablet (administered as GENVOYA) through Week 96.

Rilpivirine-Containing Regimens

Treatment outcomes of Study GS-US-264-0106 (FDA Snapshot analysis) are presented in Table 30. Switching to FTC/RPV/TDF (COMPLERA) was noninferior in maintaining HIV-1 RNA < 50 copies/mL when compared to patients who stayed on a ritonavir-boosted protease inhibitor in combination with two NRTIs (Treatment difference [95% CI]: +3.8% [-1.6% to 9.1%]).

Table 30. Virologic Outcomes of Study GS-US-264-0106

	FTC/RPV/TDF (COMPLERA) Week 48 ^a	Stayed on Baseline Regimen Week 24 ^b
	(N = 317)	(N = 159)
Virologic Success^c HIV-1 RNA < 50 copies/mL	283 (89.3%)	143 (89.9%)
Virologic Failure^d	8 (2.5%)	8 (5.0%)
No Virologic Data at Week 24 Window		
Discontinued Study Drug Due to AE or Death ^e	7 (2.2%)	0%
Discontinued Study Drug Due to Other Reasons and Last Available HIV-1 RNA < 50 copies/mL ^f	16 (5.0%)	5 (3.1%)
Missing Data During Window but on Study Drug	3 (0.9%)	3 (1.9%)

- Week 48 window is between Day 295 and 378 (inclusive).
- For patients in the SBR arm who maintained their baseline regimen for 24 weeks and then switched to COMPLERA, the Week 24 window is between Day 127 and first dose day on COMPLERA.
- Predicted difference (95% CI) of response rate for switching to COMPLERA at Week 48 compared to staying on baseline regimen at Week 24 (in absence of Week 48 results from the SBR group by study design) is -0.7% (-6.4% to 5.1%).
- Includes patients who had HIV-1 RNA \geq 50 copies/mL in the time window, patients who discontinued earlier due to lack or loss of efficacy, and patients who discontinued for reasons other than an adverse event or death, who at the time of discontinuation had HIV-1 RNA of \geq 50 copies/mL.

- e. Includes patients who discontinued due to adverse event or death at any time point from Day 1 through the time window if this resulted in no virologic data on treatment during the specified window.
- f. Includes patients who discontinued for reasons other than an adverse event, death or lack or loss of efficacy, e.g., withdrew consent, loss to follow-up, etc.

By Week 24, median CD4+ cell counts had increased significantly from baseline in both the COMPLERA arm (+10 cells/mm³, p = 0.046) and the SBR arm (+22 cells/mm³, p = 0.008) in the on-treatment analysis. The difference in median CD4+ cell count change between the COMPLERA and SBR treatment arms was not statistically significant at Week 24 (p = 0.28).

HIV-1 Infected Patients with Renal Impairment

Emtricitabine+Tenofovir Alafenamide-Containing Regimens

In Study 112, at Week 24, 95% (230/242 patients) maintained HIV-1 RNA < 50 copies/mL after switching to FTC+TAF given with EVG+COBI as a FDC tablet (administered as GENVOYA). Three patients had virologic failure at Week 24. At Week 96, 88.4% (214/242) of patients maintained HIV-1 RNA < 50 copies/mL after switching to FTC+TAF given with EVG+COBI as a FDC tablet (administered as GENVOYA). At Week 144, 83.1% (197/237) maintained HIV-1 RNA < 50 copies/mL after switching to FTC+TAF given with EVG+COBI as a FDC tablet (administered as GENVOYA); 14.8% of patients had no virologic data in the Week 144 window. Five patients among the entire study population had virologic failure at Week 144.

In a substudy, patients given FTC+TAF with EVG+COBI as a FDC tablet (administered as GENVOYA) (N=32) had no change from baseline in their actual glomerular filtration rate at Week 24, as measured by iothexol clearance.

Changes from baseline in renal laboratory tests at Weeks 24, 96, and 144 in patients who switched to FTC+TAF given with EVG+COBI as a FDC tablet (administered as GENVOYA) are presented in Table 31. The prevalence of clinically significant proteinuria (UPCR > 200 mg/g) was 42% at baseline, and decreased to 21%, 18%, and 16% at Weeks 24, 96, and 144, respectively. The prevalence of clinically significant albuminuria (UACR ≥ 30 mg/g) was 49% at baseline, and decreased to 27%, 27%, and 32% at Weeks 24, 96, and 144, respectively. Other renal assessments, including fractional excretion of uric acid, serum cystatin C, and serum phosphorus showed small changes from baseline at each time point through Weeks 24, 96, and 144. Overall, multiple assessments of renal function indicate that changes in renal functions were observed as soon as 1 week after switching to FTC+TAF when given with EVG+COBI as a FDC tablet (administered as GENVOYA) and persisted through 144 weeks.

Table 31. Change from Baseline in Renal Laboratory Tests at Week 24, and Week 96, and Week 144 in Virologically Suppressed Patients with Renal Impairment who Switched to FTC+TAF (Administered as GENVOYA) in Study 112 (Week 24, Week 96, and Week 144 Analyses)

	Week 24	Week 96	Week 144
	FTC+TAF (Administered as GENVOYA) (N = 242)		
Serum Creatinine (µmol/L) ^a	1.77 ± 22.19	-2.65 ± 24.66	-4.42 ± 25.38
Improvement in Proteinuria by Urine Dipstick ^b	57/76 (75%)	60/71 (85%)	56/66 (85%)
Urine Protein to Creatinine Ratio ^c	-35.3%	-37.7%	-45.7%
Urine Albumin to Creatinine Ratio ^c	-38.8%	-45.5%	-35.1%
Urine Retinol Binding Protein to Creatinine Ratio ^c	-56.2%	-64.1%	-63.8%
Urine Beta-2-Microglobulin to Creatinine Ratio ^c	-70.7%	-83.6%	-81.9%

- a. Mean change ± SD
 b. An improvement of at least 1 toxicity grade from baseline
 c. Median percent change

Bone Mineral Density: In virologically suppressed patients with renal impairment who switched to FTC+TAF given with EVG+COBI as a FDC tablet (administered as GENVOYA), mean percentage increases from baseline at Weeks 24, 96, and 144 were observed in hip and spine BMD. At Week 144, assessment of BMD using a threshold of 3% for changes from baseline revealed higher percentages of patients had increases versus decreases from baseline in BMD at both hip and spine.

At week 144, virologically suppressed patients who switched to FTC+TAF given with EVG+COBI as a FDC (administered as GENVOYA) from a TDF-based regimen achieved a higher median percentage increase from baseline in hip and spine BMD, compared to patients who switched from a non-TDF based regimen.

15. MICROBIOLOGY

Antiviral Activity

Emtricitabine, Rilpivirine and Tenofovir Alafenamide

The combinations of FTC, RPV, and TAF were not antagonistic and showed synergistic effects with each other in cell culture combination antiviral activity assays.

Emtricitabine

The antiviral activity of FTC against laboratory and clinical isolates of HIV-1 was assessed in lymphoblastoid cell lines, the MAGI-CCR5 cell line, and peripheral blood mononuclear cells. The 50% effective concentration (EC₅₀) values for FTC were in the range of 0.0013 to 0.64 µM.

Emtricitabine displayed antiviral activity in cell culture against HIV-1 clades A, B, C, D, E, F, and G (EC₅₀ values ranged from 0.007 to 0.075 µM) and showed strain specific activity against HIV-2 (EC₅₀ values ranged from 0.007 to 1.5 µM).

In two-drug combination studies of FTC with NRTIs (abacavir, didanosine, lamivudine, stavudine, tenofovir, and zidovudine), NNRTIs (delavirdine, efavirenz, nevirapine, and RPV), protease inhibitors (PIs) (amprenavir, nelfinavir, ritonavir, and saquinavir), and the integrase strand transfer inhibitor (INSTI) EVG, additive to synergistic effects were observed. No antagonism was observed for these combinations.

Rilpivirine

Rilpivirine exhibited activity against laboratory strains of wild-type HIV-1 in an acutely infected T-cell line with a median EC₅₀ value for HIV-1/IIIB of 0.73 nM. Rilpivirine demonstrated limited activity in cell culture against HIV-2 with a median EC₅₀ value of 5,220 nM (range 2,510–10,830 nM).

Rilpivirine demonstrated antiviral activity against a broad panel of HIV-1 group M (subtype A, B, C, D, F, G, H) primary isolates with EC₅₀ values ranging from 0.07 to 1.01 nM and group O primary isolates with EC₅₀ values ranging from 2.88 to 8.45 nM.

Rilpivirine showed additive to synergistic antiviral activity in combination with the NRTIs (abacavir, didanosine, FTC, lamivudine, stavudine, tenofovir, and zidovudine); the PIs (amprenavir, atazanavir, darunavir, indinavir, lopinavir, nelfinavir, ritonavir, saquinavir, and tipranavir); the NNRTIs (EFV, etravirine, and nevirapine); the fusion inhibitor enfuvirtide; the entry inhibitor maraviroc; and the integrase inhibitor raltegravir.

Tenofovir Alafenamide

The antiviral activity of TAF against laboratory and clinical isolates of HIV-1 subtype B was assessed in lymphoblastoid cell lines, PBMCs, primary monocyte/macrophage cells, and CD4-T lymphocytes. The EC₅₀ values for TAF were in the range of 2.0 to 14.7 nM.

Tenofovir alafenamide displayed antiviral activity in cell culture against all HIV-1 groups (M, N, O), including subtypes A, B, C, D, E, F, and G (EC₅₀ values ranged from 0.10 to 12.0 nM) and strain-specific activity against HIV-2 (EC₅₀ values ranged from 0.91 to 2.63 nM).

In a study of TAF with a broad panel of representatives from the major classes of approved anti-HIV agents (NRTIs, NNRTIs, INSTIs, and PIs), additive to synergistic effects were observed. No antagonism was observed for these combinations.

Resistance

In Cell Culture

Emtricitabine

HIV-1 isolates with reduced susceptibility to FTC have been selected in cell culture. Reduced susceptibility to FTC was associated with M184V/I substitutions in HIV-1 RT.

Rilpivirine

Rilpivirine-resistant strains were selected in cell culture starting from wild-type HIV-1 of different origins and subtypes as well as NNRTI-resistant HIV-1. The frequently observed amino acid substitutions that emerged and conferred decreased phenotypic susceptibility to RPV included: L100I, K101E, V106I and A, V108I, E138K and G, Q, R, V179F and I, Y181C and I, V189I, G190E, H221Y, F227C, and M230I and L.

Tenofovir Alafenamide

HIV-1 isolates with reduced susceptibility to TAF have been selected in cell culture. HIV-1 isolates selected by TAF expressed a K65R mutation in HIV-1 RT; in addition, a K70E substitution in HIV-1 RT has been transiently observed. In vitro drug resistance selection studies with TAF have shown no development of resistance increases above 2.5-fold after 6 months in culture.

In Clinical Trials

In Treatment-naïve Patients

Emtricitabine and Tenofovir Alafenamide

In a pooled analysis of antiretroviral-naïve patients receiving FTC+TAF given with EVG+COBI as a FDC tablet (administered as GENVOYA) in Phase 3 Studies 104 and 111, genotyping was performed on plasma HIV-1 isolates from all patients with HIV-1 RNA \geq 400 copies/mL at confirmed virologic failure, at Week 144, or at time of early study drug discontinuation. As of Week 144, the development of one or more primary FTC, TAF, or EVG resistance-associated mutations was observed in 12 of 22 patients with evaluable genotypic data from paired baseline and EVG+COBI+FTC+TAF treatment-failure isolates (12 of 866 patients [1.4%]) compared with 12 of 20 treatment-failure isolates from patients with evaluable genotypic data in the EVG+COBI+FTC+TDF group (12 of 867 patients [1.4%]). Of the 12 patients with resistance development in the EVG+COBI+FTC+TAF group, the mutations that emerged were M184V/I (N = 11) and K65R/N (N = 2) in reverse transcriptase and

T66T/A/I/V (N = 2), E92Q (N = 4), Q148Q/R (N = 1), and N155H (N = 2) in integrase. Of the 12 patients with resistance development in the EVG+COBI+FTC+TDF group, the mutations that emerged were M184V/I (N = 9), K65R/N (N = 4), and L210LW (N = 1) in reverse transcriptase and E92Q/V (N = 4), Q148R (N = 2) and N155H/S (N = 3) in integrase. In both treatment groups, most patients who developed resistance mutations to EVG in integrase also developed resistance mutations to FTC in reverse transcriptase.

In phenotypic analyses of patients in the final resistance analysis population, 7 of 22 patients (32%) had HIV-1 isolates with reduced susceptibility to EVG in the EVG+COBI+FTC+TAF group compared with 7 of 20 patients (35%) in the EVG+COBI+FTC+TDF group, 8 patients (36%) had reduced susceptibility to FTC in the EVG+COBI+FTC+TAF group compared with 7 patients (35%) in the EVG+COBI+FTC+TDF group. One patient in the EVG+COBI+FTC+TAF group (1 of 22 [4.5%]) and 2 patients in the EVG+COBI+FTC+TDF group (2 of 20 [10%]) had reduced susceptibility to tenofovir.

Rilpivirine-Containing Regimens

In the pooled analysis from two Phase III trials (C209 and C215), the emergence of resistance was greater among patients receiving RPV in combination with FTC/TDF as compared to the control (EFV in combination with FTC/TDF) arm at Week 48 (11.5%, 4.2%, respectively) and at Week 96 (14.2%, 6.8%, respectively). Fewer virologic failures due to resistance occurred between Week 48 and Week 96 in each treatment arm (2.7% and 2.6% in the RPV and control arms, respectively). Through week 96, fewer patients with baseline viral load \leq 100,000 copies/mL had genotypic and/or phenotypic resistance to RPV (2.4%) as compared to patients with baseline viral load $>$ 100,000 copies/mL (11.4%). In the Week 96 pooled resistance analysis for patients treated with RPV/FTC/TDF resistance data were available for 71 of the 78 virologic failures. The most common emergent NNRTI substitutions in these patients included V90I, K101E/P/T, E138K/A/Q/G, V179I/L, Y181C/I, V189I, H221Y, F227C/L and M230L, which were associated with an RPV phenotypic fold change range of 2.6–621. However, in the trials, the presence of the substitutions V90I and V189I at baseline did not affect the virologic response. The E138K substitution emerged most frequently during RPV treatment at Week 48 and Week 96, commonly in combination with the M184I mutation. The amino acid substitutions associated with NRTI resistance that developed in 3 or more patients treated with RPV were: K65R, K70E, M184V/I, and K219E. The most common mutations were the same in the Week 48 and Week 96 analyses.

The FTC and lamivudine resistance-associated substitutions M184I or V and NRTI resistance-associated substitutions (K65R/N, A62V, D67N/G, K70E, Y115F, K219E/R) emerged more frequently in the RPV resistance-analysis patients than in EFV resistance-analysis patients.

In Virologically Suppressed Patients

Emtricitabine and Tenofovir Alafenamide

Three patients with emergent resistance to FTC and/or EVG were identified (M184M/I; M184I + E92G; M184V + E92Q) as of Week 96 in a clinical study of virologically suppressed patients who switched from a regimen containing FTC+TDF to FTC+TAF given with EVG+COBI in a FDC tablet (administered as GENVOYA) (Study 109, N = 959).

Rilpivirine-Containing Regimens

Study GS-US-264-0106

Of the 469 patients treated with FTC/RPV/TDF (317 patients who switched to FTC/RPV/TDF at baseline and 152 patients who switched at Week 24), a total of 7 patients were analyzed for resistance development and had genotypic and phenotypic data available. Through Week 24, 2 patients who switched to FTC/RPV/TDF at baseline (2/317, 0.6%) and 1 patient who maintained their protease inhibitor-based regimen (1/159 patients, 0.6%) developed genotypic and/or phenotypic resistance to study drugs. After Week 24, 2 additional patients who switched to FTC/RPV/TDF at baseline developed resistance by Week 48 (total of 4 of 469 patients, 0.9%). The most common emergent resistance mutations in FTC/RPV/TDF -treated patients were M184V/I and E138K in reverse transcriptase. All patients remained susceptible to tenofovir.

Of the patients treated with FTC/RPV/TDF who had historical evidence of the NNRTI-associated K103N substitution, 17 of 18 patients who switched to FTC/RPV/TDF at baseline and 5 of 6 patients who switched to FTC/RPV/TDF at Week 24 maintained virologic suppression through 48 weeks and 24 weeks of FTC/RPV/TDF treatment, respectively.

Cross Resistance

In HIV-1 Infected Treatment-Naïve Patients or Virologically Suppressed Patients

Considering all of the available *in vitro* and *in vivo* data in treatment-naïve patients the following resistance-associated substitutions, when present at baseline, may affect the activity of ODEFSEY: K65R, K70E, K101E, K101P, E138A, E138G, E138K, E138Q, E138R, V179L, Y181C, Y181I, Y181V, M184I, M184V, Y188L, H221Y, F227C, M230I, M230L, and the combination of L100I+K103N.

Emtricitabine

Emtricitabine-resistant viruses with the M184V/I substitution were cross-resistant to lamivudine, but retained sensitivity to didanosine, stavudine, tenofovir, and zidovudine.

Viruses harboring mutations conferring reduced susceptibility to stavudine and zidovudine —thymidine analogue-associated mutations—TAMs (M41L, D67N, K70R,

L210W, T215Y/F, K219Q/E), or didanosine (L74V) remained sensitive to FTC. HIV-1 containing the K103N substitution or other substitutions associated with resistance to NNRTIs was susceptible to FTC.

Rilpivirine-Containing Regimens

No significant cross-resistance has been demonstrated between RPV-resistant HIV-1 variants to FTC or tenofovir, or between FTC- or tenofovir-resistant variants and RPV.

In Treatment-Naïve Adult Patients

In the Week 96 pooled analysis for patients receiving RPV in combination with FTC/TDF in the two Phase III trials of 66 patients with virologic failure for whom phenotypic resistance data were available, 40 (60%) had reduced susceptibility to FTC, 31 (47%) to RPV, 39 (59%) to lamivudine and 2 (3%) to tenofovir. Of the 29 patients with virologic failure on EFV (control) in combination with FTC/TDF for whom phenotypic resistance data was available 12 (41.4%) had reduced susceptibility to EFV, 5 (17.2%) to FTC, 6 (20.7%) to lamivudine and 1 (3.4%) to tenofovir. Of the 31 patients who had reduced susceptibility to RPV, 31 (100%) were resistant to etravirine, 28 (90%) to EFV, and 13 (42%) to nevirapine. Of the 12 patients who lost susceptibility to EFV, 1 (8%) was resistant to etravirine, none to RPV, and 12 (100%) to nevirapine.

In the Week 96 pooled analyses, fewer patients with baseline viral load \leq 100,000 copies/ml had phenotypic cross-resistance to other NNRTIs (4/7) as compared to patients with baseline viral load $>$ 100,000 copies/ml (28/30).

Virologically Suppressed Adult Patients

In Study GS-US-264-0106, 4 of the 469 patients that switched from a protease inhibitor-based regimen to FTC/RPV/TDF had reduced susceptibility to at least one component of FTC/RPV/TDF through Week 48. Among these patients, all 4 lost susceptibility to FTC and 2 lost susceptibility to RPV. Patients with resistance to FTC also were resistant to lamivudine. These patients with resistance to RPV developed phenotypic cross-resistance to the other NNRTIs delavirdine, EFV, and nevirapine, but remained susceptible to etravirine in 1 of 2 cases.

In Vitro

In a panel of 67 HIV-1 recombinant laboratory strains with one amino acid substitution at RT positions associated with NNRTI resistance, including the most commonly found K103N and Y181C, RPV showed antiviral activity against 64 (96%) of these strains. The single amino acid substitutions associated with a loss of susceptibility to RPV were: K101P and Y181V/I. The K103N substitution did not result in reduced susceptibility to RPV by itself, but the combination of K103N with L100I resulted in a 7-fold reduced susceptibility to RPV. In another study, the Y188L substitution resulted in a reduced susceptibility to RPV of 9-fold for clinical isolates and 6-fold for site-directed mutants.

Tenofovir Alafenamide

The K65R and K70E mutations result in reduced susceptibility to abacavir, didanosine, lamivudine, FTC, TAF, and tenofovir, but retain sensitivity to zidovudine.

Multinucleoside resistant HIV-1 with a T69S double insertion mutation or with a Q151M mutation complex including K65R showed reduced susceptibility to TAF.

HIV-1 containing the K103N or Y181C mutations associated with resistance to NNRTIs was susceptible to TAF.

HIV-1 containing mutations associated with resistance to PIs, such as M46I, I54V, V82F/T, and L90M, were susceptible to TAF.

16. NON-CLINICAL TOXICOLOGY

General

No toxicology studies have been conducted with ODEFSEY tablets. The toxicology information is based on studies conducted with FTC, RPV or TAF as individual agents.

Rilpivirine

Animal toxicology studies have been conducted with RPV in mice, rats, rabbits, dogs, and cynomolgus monkeys. The target organs and systems of toxicity were the adrenal cortex and the associated steroid biosynthesis (mouse, rat, dog, cynomolgus monkey), the reproductive organs (female mouse, male and female dog), the liver (mouse, rat, dog), the thyroid and pituitary gland (rat), the kidney (mouse, dog), the hematopoietic system (mouse, rat, dog), and the coagulation system (rat).

Nonclinical studies in rats, dogs and monkeys revealed bone and kidney as the primary target organs of toxicity.

Tenofovir alafenamide

The general toxicology profile of TAF has been studied in mice, rats, dogs and monkeys. Nonclinical studies in rats and dogs revealed bone and kidney as the primary target organs of toxicity. The effects on the kidneys included cortical tubular basophilia and tubular karyomegaly in both rats and dogs and additionally cortical tubular degeneration/regeneration in dogs. These effects did not appear to meaningfully affect renal function except for possibly related reduction in serum calcitriol (1,25-dihydroxyvitamin D3) that may be implicated in the bone effects (see below). The TAF-related effects on the bone included decreases in BMD and mineral content observed in both rats and dogs. In the 9-month dog study, animals dosed at 18/12 mg/kg/day (approximately 47 times the clinical exposure based on AUC) failed to mature skeletally.

The NOAEL in the rat and dog was 25 mg/kg/day (approximately 13 times clinical tenofovir exposure based on AUC) and 2 mg/kg/day (approximately 4 times the clinical tenofovir exposure based on AUC), respectively. These effects were partially reversible upon treatment discontinuation.

Electrocardiographic effects occurred in the 9-month dog study and included prolongation of PR intervals at ≥ 6 mg/kg (approximately 15 times the clinical exposure based on AUC) and reduction in heart rate with an associated QT prolongation at 18/12 mg/kg (approximately 47 times the clinical exposure based on AUC); the heart rate changes were reversible following a three-month recovery period. The NOAEL was 2 mg/kg (approximately 4 times the clinical tenofovir exposure based on AUC). These effects might have been due to a reduction in triiodothyronine (T3) levels.

Carcinogenesis

Emtricitabine

In long-term carcinogenicity studies of FTC, no drug-related increases in tumor incidence were found in mice at doses up to 750 mg/kg/day (23 times the human systemic exposure at the therapeutic dose of 200 mg/day) or in rats at doses up to 600 mg/kg/day (28 times the human systemic exposure at the therapeutic dose).

Rilpivirine

RPV was evaluated for carcinogenic potential by oral gavage administration to mice and rats up to 104 weeks. Daily doses of 20, 60, and 160 mg/kg/day were administered to mice and doses of 40, 200, 500, and 1500 mg/kg/day were administered to rats. An increase in the incidences of hepatocellular adenomas and carcinomas was observed in mice and rats. An increase in the incidences of follicular cell adenomas and/or carcinomas in the thyroid gland was observed in rats. Administration of RPV did not cause a statistically significant increase in the incidence of any other benign or malignant neoplasm in mice or rats. The observed hepatocellular findings in mice and rats are considered to be rodent specific, associated with liver enzyme induction. A similar mechanism does not exist in humans; hence, these tumors are not relevant for humans. The follicular cell findings are considered to be rat specific, associated with increased clearance of thyroxine and are not considered to be relevant for humans. At the lowest tested doses in the carcinogenicity studies, the systemic exposures (based on AUC) to RPV were 21 fold (mice) and 3 fold (rats), relative to those observed in humans at the recommended dose (25 mg once daily).

Tenofovir Alafenamide

Because there is a lower tenofovir exposure in rats and mice after TAF administration compared to TDF, carcinogenicity studies were conducted only with TDF. Long-term oral carcinogenicity studies of TDF in mice and rats were carried out at exposures up to approximately 10 times (mice) and 4 times (rats) those observed in humans at the 300 mg therapeutic dose of TDF for HIV-1 infection. At the high dose in female mice, liver adenomas were increased at exposures 10 times that in humans. In rats, the study was negative for carcinogenic findings at exposures up to 4 times that observed in humans at the therapeutic dose.

Mutagenesis

Emtricitabine

Emtricitabine was not genotoxic in the reverse mutation bacterial test (Ames test), mouse lymphoma or mouse micronucleus assays.

Rilpivirine

Rilpivirine has tested negative in the *in vitro* Ames reverse mutation assay, *in vitro* chromosomal aberration assay in human lymphocyte, and *in vitro* clastogenicity mouse lymphoma assay, tested in the absence and presence of a metabolic activation system. RPV did not induce chromosomal damage in the *in vivo* micronucleus test in mice.

Tenofovir Alafenamide

Tenofovir alafenamide was not genotoxic in the reverse mutation bacterial test (Ames test), mouse lymphoma or rat micronucleus assays.

Reproductive Toxicology

Emtricitabine

The incidence of fetal variations and malformations was not increased in embryofetal toxicity studies performed with FTC in mice at exposures (AUC) approximately 60-fold higher and in rabbits at approximately 120-fold higher than human exposures at the recommended daily dose.

Emtricitabine did not affect fertility in male rats at approximately 140-fold or in male and female mice at approximately 60-fold higher exposures (AUC) than in humans given the recommended 200 mg daily dose. Fertility was normal in the offspring of mice exposed daily from before birth (in utero) through sexual maturity at daily exposures (AUC) of approximately 60-fold higher than human exposures at the recommended 200 mg daily dose.

Rilpivirine

In a study conducted in rats, there were no effects on mating or fertility with RPV up to 400 mg/kg/day, a dose of RPV that showed maternal toxicity. This dose is associated with an exposure that is approximately 40 times higher than the exposure in humans at the recommended dose of 25 mg once daily. Studies in animals have shown no evidence of relevant embryonic or fetal toxicity or an effect on reproductive function. There was no teratogenicity with RPV in rats and rabbits. The exposures at the embryo fetal NOAELs in rats and rabbits were respectively 15 and 70 times higher than the exposure in humans at the recommended dose of 25 mg once daily. In a pre- and postnatal development assessment in rats, RPV had no effect on development of offspring during lactation or postweaning when the mothers were dosed up to 400 mg/kg/day.

Tenofovir Alafenamide

There were no effects on fertility when TAF was administered to male rats at a dose equivalent to 155 times the human dose based on body surface area comparisons for 28 days prior to mating and to female rats for 14 days prior to mating through day seven of gestation.

ODEFSEY (emtricitabine/rilpivirine*/tenofovir alafenamide**) tablets
*as rilpivirine hydrochloride **as tenofovir alafenamide hemifumarate
Product Monograph

17. SUPPORTING PRODUCT MONOGRAPHS

COMPLERA (emtricitabine 200mg/rilpivirine 25mg/tenofovir disoproxil fumarate 300mg) tablets, Control No. 186081, Product Monograph, Gilead Sciences Canada, Inc. September 11, 2015.

EDURANT (rilpivirine 25mg) tablets, Control No. 223865, Product Monograph, Janssen Inc. March 04, 2019.

EMTRIVA (emtricitabine 200mg) capsules, Control No. 165814, Product Monograph, Gilead Sciences Canada, Inc. September 05, 2013.

GENVOYA (elvitegravir 150 mg/cobicistat 150 mg/emtricitabine 200 mg/tenofovir alafenamide 10 mg) tablets, Control No. 224195, Product Monograph, Gilead Sciences Canada, Inc. May 07, 2019.

READ THIS FOR SAFE AND EFFECTIVE USE OF YOUR MEDICINE

PATIENT MEDICATION INFORMATION

ODEFSEY®
(emtricitabine/rilpivirine*/tenofovir alafenamide) tablets**
***as rilpivirine hydrochloride**
****as tenofovir alafenamide hemifumarate**

Read this carefully before you start taking **Odefsey** and each time you get a refill. This leaflet is a summary and will not tell you everything about this drug. Talk to your healthcare professional about your medical condition and treatment and ask if there is any new information about **Odefsey**.

Serious Warnings and Precautions

- **“Flare-ups” of Hepatitis B Virus infection**, in which the disease suddenly returns in a worse way than before, can occur if you also have hepatitis B and stop taking **Odefsey**. Do not stop taking **Odefsey** without your doctor’s advice. If you stop taking **Odefsey**, tell your doctor immediately about any new, unusual or worsening symptoms that you notice after stopping treatment. After you stop taking **Odefsey**, your doctor will still need to check your health and take blood tests to check your liver. **Odefsey** is not approved for the treatment of hepatitis B virus infection.

What is Odefsey used for?

Odefsey is used to treat people with Human Immunodeficiency Virus (HIV) infection. **Odefsey** is for adults.

Odefsey is for people who do not have an HIV virus that is resistant to **Odefsey**. **Odefsey** has not been studied in children under 18 years of age.

How does Odefsey work?

Odefsey lowers the amount of HIV in the blood (viral load).

HIV infection destroys CD4+ (T) cells. These cells are important to help the immune system fight infections. After a large number of T cells are destroyed, acquired immune deficiency syndrome (AIDS) develops.

Odefsey may help increase the count of CD4+ (T) cells. Lowering the amount of HIV in the blood and increasing the CD4+ (T) cells lower the chance of getting infections that happen when your immune system is weak.

Odefsey does not cure HIV infection or AIDS. The long-term effects of **Odefsey** are not known. People taking **Odefsey** may still get infections or other conditions that happen with HIV infection. Some of these conditions are pneumonia and *Mycobacterium avium* complex (MAC) infections. **It is very important that you see your doctor on a regular basis while taking Odefsey.**

Odefsey has not been shown to reduce the risk of passing HIV to others through sexual contact or blood. Continue to practice safe sex. Use condoms to lower the chance of sexual contact with body fluids such as semen, vaginal secretions, or blood. Do not re-use or share needles.

What are the ingredients in Odefsey?

Medicinal ingredients: emtricitabine, rilpivirine*, tenofovir alafenamide**
(*as rilpivirine hydrochloride, **as tenofovir alafenamide hemifumarate)

Nonmedicinal ingredients: croscarmellose sodium, lactose monohydrate, magnesium stearate, microcrystalline cellulose, polysorbate 20 and povidone. The coating of the tablets contains polyvinyl alcohol, titanium dioxide, macrogol/polyethylene glycol, talc, and iron oxide black.

Odefsey comes in the following dosage forms:

Odefsey comes in tablets. Each tablet contains emtricitabine (200 milligrams), rilpivirine (25 milligrams) (as 27.5 milligrams of rilpivirine hydrochloride) and tenofovir alafenamide (25 milligrams) (as 28.0 milligrams of tenofovir alafenamide hemifumarate). **Odefsey** tablets are gray. They have a capsule-shape. The tablets say “GSI” on one side and “255” on the other side. Each bottle contains 30 tablets. The bottle has a cap that children cannot open. The bottle also contains some polyester coil (which looks white and fluffy) and a small packet of silica gel drying agent. Do NOT eat the coil or drying agent. They are meant to keep your medicine fresh.

Do not use Odefsey if:

- you are allergic to emtricitabine, rilpivirine, tenofovir alafenamide or any of the other ingredients in this product. (Read also “**What are the ingredients in Odefsey?**” above.)
- you are taking any of the following drugs:

Drugs that must not be taken with Odefsey (contraindicated):

Drug Class	Medicinal Ingredient (Brand Name)
Anticonvulsants	carbamazepine (Tegretol [®] , Tegretol CR [®]), oxcarbazepine (Trileptal [®]), phenobarbital (Phenobarb [®]) and phenytoin (Dilantin [®] , Tremytoine [®])
Antimycobacterial	rifampin (Rifadin [®] , Rifamate ^{®*} , Rifater [®] , Rofact [®]), and rifapentine*

Drug Class	Medicinal Ingredient (Brand Name)
Glucocorticoid	systemic dexamethasone (more than 1 dose) or dexamethasone sodium phosphate
Herbal products	<i>Hypericum perforatum</i> (St. John's wort)
Proton pump inhibitor	dexlansoprazole (Dexilant®), esomeprazole (Nexium®, Vimovo®), lansoprazole (Prevacid®), omeprazole (Losec®, Olex®), pantoprazole sodium (Pantoloc®, Panto IV®), rabeprazole (Pariet®)

*Not available in Canada

The following drugs should also not be taken with Odefsey:

- Adefovir dipivoxil (HEPSERA®).
- Any other medicines to treat HIV-1 infection.
- Any other medicines that contain tenofovir alafenamide (BIKTARVY®, GENVOYA®, DESCOVY®, Symtuza™, VEMLIDY®).
- Any other medicines that contain tenofovir disoproxil fumarate (ATRIPLA®, COMPLERA®, STRIBILD®, TRUVADA®, VIREAD®).
- Any other medicines that contain emtricitabine or lamivudine (3TC®, ATRIPLA, BIKTARVY, COMPLERA, GENVOYA, EMTRIVA®, STRIBILD, Symtuza, TRUVADA; Combivir®, Heptovir®, Kivexa®, Triumeq®, Trizivir®).
- Any other medicines that contain rilpivirine (COMPLERA, Edurant®).

To help avoid side effects and ensure proper use, talk to your doctor before you take Odefsey. Talk about any health conditions or problems you may have, including if you:

- Also have a hepatitis B virus (HBV) infection at the same time and take **Odefsey**. Your HBV infection may get worse (flare-up) and symptoms worsen if you stop taking **Odefsey** (see Serious Warnings and Precautions box and Serious Side Effects table).
- Have a history of pancreatitis (swelling of the pancreas). If you develop symptoms of pancreatitis, such as nausea, vomiting and severe pain in the abdomen and/or back, contact your doctor.
- Have serious liver problems or kidney problems.
- Have bone problems.

- Have heart problems (eg, irregular heartbeat, QT prolongation).
- Have lactic acidosis (high levels of acid in the blood). See the Serious Side Effects table for symptoms and contact your doctor right away if you get these symptoms.
- Have severe liver problems including enlarged or fatty liver. See the Serious Side Effects table for symptoms and contact your doctor right away if you get these symptoms.
- Were born with the rare problem of not being able to tolerate galactose (severe lack of lactase or cannot absorb glucose or galactose). **Odefsey** has lactose.

Do not run out of **Odefsey**. Refill your prescription or talk to your doctor before your **Odefsey** is all gone.

- Do not stop taking **Odefsey** without first talking to your doctor.

If you stop taking **Odefsey**, your doctor will need to check your health often and do blood tests regularly for several months to check your HBV infection. Tell your doctor about any new or unusual symptoms you may have after you stop taking **Odefsey**.

Other warnings you should know about:

If you are pregnant or plan to become pregnant:

It is not known if **Odefsey** can harm your unborn child. Your doctor will decide if you should take **Odefsey**.

Pregnancy Registry: There is a pregnancy registry for women who take HIV-1 medicines during pregnancy. The purpose of this registry is to collect information about the health of you and your baby. If you become pregnant while taking **Odefsey**, talk with your doctor taking part in this registry.

If you are breastfeeding or plan to breastfeed:

Do not breastfeed if you take **Odefsey**. You should not breastfeed if you have HIV because of the chance of passing the HIV virus to your baby. At least one of the medicines, emtricitabine, can pass to your baby in your breast milk and may cause harm to the baby. It is not known if the other medicines in **Odefsey** can pass into your breast milk. If you are a woman who has or will have a baby, talk with your doctor about the best way to feed your baby.

Grapefruit or grapefruit juice can affect how **Odefsey** works. Avoid eating grapefruit or drinking grapefruit juice while you are taking **Odefsey**.

Blood Sugar and Fat Levels

Your blood sugar levels (glucose) or level of fats (lipids) in your blood may increase with HIV treatment. Your doctor may order blood tests for you.

Kidney Tests

Your healthcare professional should do blood and urine tests to check your kidneys before you start and during treatment with ODEFSEY.

Tell your healthcare professional about all the medicines you take, including any drugs, vitamins, minerals, natural supplements or alternative medicines.

Drugs that interact with Odefsey and where the dose of Odefsey or the dose of the other drug should be changed or other direction is needed:

Drug Class	Medicinal Ingredient (Brand Name)
Antacids	antacids containing aluminum hydroxide, magnesium hydroxide, or calcium carbonate. Take antacids at least 2 hours before or 4 hours after you take Odefsey .
Antimycobacterials	rifabutin (Mycobutin [®])
Antifungals	fluconazole (Diflucan [®] , Monicure [®]), itraconazole (Sporanox [®]), ketoconazole (Nizoral [®]), posaconazole (Posanol [®]) and voriconazole (Vfend [®])
H ₂ -Receptor antagonists	cimetidine, famotidine, nizatidine, ranitidine. Take H ₂ -receptor antagonists at least 12 hours before or 4 hours after you take Odefsey .
Immunosuppressants	cyclosporine (Neoral [®]), sirolimus (Rapamune [®]) and tacrolimus (Prograf [®])
Antibacterials	clarithromycin (Biaxin [®]) and telithromycin (Ketek [®])
Narcotic analgesics	methadone (Metadol [®] , Methadose)

These are not all the medicines that may cause problems if you take Odefsey. Be sure to tell your doctor about all the medicines you take.

Keep a complete list of all the prescription, nonprescription, and herbal medicines that you are taking, how much you take and how often you take them. Make a new list when medicines or herbal medicines are added or stopped, or if the dose changes. Give copies of this list to all your doctors and pharmacists **every** time you visit them or fill a prescription. This will give your doctor a complete picture of the medicines you use. Then he or she can decide the best approach for the situation.

How to take Odefsey:

Stay under a doctor's care when taking **Odefsey**. Do not change your treatment or stop treatment without first talking with your doctor.

When your **Odefsey** supply starts to run low, get more from your doctor or pharmacy. This is very important because the amount of virus in your blood may increase if the

medicine is stopped for even a short time. If **Odefsey** is not taken on a regular basis, as prescribed, the HIV virus may become harder to treat.

Only take medicine that has been prescribed specifically for you.

Do not give **Odefsey** to others or take medicine prescribed for someone else.

Do not use if seal over bottle opening is broken or missing.

Usual dose: Adults:

- Take one tablet (by mouth) once each day with a meal. Try to take the tablet at the same time each day. Swallow with plenty of water.
- **Always take Odefsey with a meal.** A meal is important to get the right drug levels in your body. A protein drink alone does not replace a meal.

Overdose:

If you think you have taken too much **Odefsey**, contact your healthcare professional, hospital emergency department or regional Poison Control Centre immediately, even if there are no symptoms.

Missed Dose:

It is important to take **Odefsey** each day.

- **If you miss a dose of Odefsey** and you notice within 12 hours, take a tablet with a meal as soon as you can. Then take the next dose at your usual time.
- **If you miss a dose of Odefsey** and you notice after 12 hours, wait and take the next dose at your usual time. Do NOT take a double dose (two doses close together).

What to do if you vomit (throw up):

- If you vomit **less than 4 hours** after taking **Odefsey**, take another tablet with a meal.
- If you vomit **more than 4 hours** after taking **Odefsey**, wait. Do NOT take another tablet until you are scheduled to take the next tablet.

Call your doctor or pharmacists if you are not sure what to do.

What are possible side effects from using Odefsey?

These are not all the possible side effects you may feel when taking **Odefsey**. If you get any side effects not listed here, contact your doctor. Please also see Serious Warnings and Precautions box.

The common side effects of **Odefsey** are:

- Trouble sleeping (insomnia).
- Headache.
- Nausea.
- Tiredness.
- Depression.

Additional side effect may include:

- Gas.
- Hives (urticaria).
- Abdominal discomfort.

Changes in your immune system (Immune Reconstitution Inflammatory Syndrome) can happen when you start taking HIV-1 medicines. Your immune system may get stronger and begin to fight infections that have been hidden in your body for a long time.

Autoimmune disorders (when the immune system attacks healthy body tissue), may also occur after you start taking medicines for HIV infection. Examples of this include: Grave's disease (which affects the thyroid gland), Guillain-Barré syndrome (which affects the nervous system), polymyositis (which affects the muscles), or autoimmune hepatitis (which affects the liver). Autoimmune disorders may occur many months after the start of treatment. Look for any other symptoms such as:

- high temperature (fever), redness, rash or swelling
- joint or muscle pain
- numbness or weakness beginning in the hands and feet and moving up towards the trunk of the body
- palpitations (chest pain) or rapid heart rate

If you notice these or any symptoms of inflammation or infection, tell your doctor immediately.

Bone problems can happen in some people who take **Odefsey**. Bone problems may include bone pain, softening or thinning (which may lead to fractures). Your doctor may need to do tests to check your bones.

Tell your doctor if you have any side effect that bothers you or that does not go away.

These are not all the possible side effects of **Odefsey**. For more information, ask your doctor or pharmacist.

Serious side effects and what to do about them			
Symptoms / effect	Talk to your healthcare professional		Stop taking drug and get immediate medical help
	Only if severe	In all cases	
<p><u>COMMON</u> Effect: Depression or mood changes Symptoms:</p> <ul style="list-style-type: none"> • Feel sad or hopeless • Feel anxious or restless • Have thoughts of hurting yourself (suicide) or have tried to hurt yourself 		<ul style="list-style-type: none"> ✓ ✓ ✓ 	
<p><u>UNCOMMON</u> Effect: Severe skin rash and allergic reactions Symptoms:</p> <ul style="list-style-type: none"> • Severe allergic reactions causing a swollen face, lips, mouth, tongue or throat, which may lead to difficulty swallowing or breathing • Mouth sores or blisters on your body • Inflamed eyes (conjunctivitis) • Fever, dark urine, or pain on the right side of the stomach-area (abdominal pain) 		<ul style="list-style-type: none"> ✓ ✓ ✓ ✓ 	
<p><u>RARE</u> Effect: Lactic acidosis Symptoms:</p> <ul style="list-style-type: none"> • Feeling very weak or tired • Unusual muscle pain • Stomach pain with nausea and vomiting • Feeling unusually cold especially in arms and legs • Feeling dizzy or lightheaded • Fast or irregular heartbeat • Fast and deep breathing 		<ul style="list-style-type: none"> ✓ ✓ ✓ ✓ ✓ ✓ ✓ 	

Serious side effects and what to do about them			
Symptoms / effect	Talk to your healthcare professional		Stop taking drug and get immediate medical help
	Only if severe	In all cases	
<p><u>VERY RARE</u> Effect: Flare-ups of hepatitis B virus infection following drug discontinuation Symptoms:</p> <ul style="list-style-type: none"> • Jaundice (skin or the white part of eyes turn yellow) • Urine turns dark • Bowel movements (stools) turn light in color • Loss of appetite for several days or longer • Feeling sick to your stomach (nausea) • Lower stomach pain 		✓ ✓ ✓ ✓ ✓ ✓	
<p><u>VERY RARE</u> Effect: Hepatobiliary toxicity (severe liver or gallbladder problems) with hepatomegaly (liver enlargement) and steatosis (fat in the liver) Symptoms:</p> <ul style="list-style-type: none"> • Jaundice (skin or the white part of eyes turn yellow) • Urine turns dark • Bowel movements (stools) turn light in color • Loss of appetite for several days or longer • Feeling sick to your stomach (nausea) • Lower stomach pain • Back and shoulder pain 		✓ ✓ ✓ ✓ ✓ ✓ ✓	

If you have a troublesome symptom or side effect that is not listed here or becomes bad enough to interfere with your daily activities, talk to your healthcare professional.

Reporting Side Effects

You can report any suspected side effects associated with the use of health products to Health Canada by:

- Visiting the Web page on Adverse Reaction Reporting (www.canada.ca/en/health-canada/services/drugs-health-products/medeffect-canada) for information on how to report online, by mail or by fax; or
- Calling toll free at 1-866-234-2345.

NOTE: Contact your healthcare professional if you need information about how to manage your side effects. The Canada Vigilance Program does not provide medical advice.

Storage:

- Store **Odefsey** below 30 °C (86 °F).
- Keep **Odefsey** in its original container and keep the container tightly closed.
- Keep this medication where children cannot reach it or see it.

If you want more information about Odefsey:

- Talk to your healthcare professional.
- Find the full product monograph that is prepared for healthcare professionals and includes this Patient Medication Information by visiting the Health Canada website (www.canada.ca/en/health-canada/services/drugs-health-products/drug-products/drug-product-database); the manufacturer's website www.gilead.ca, or by calling 1-866-207-4267.

This leaflet was prepared by Gilead Sciences Canada, Inc.

Last Revised: November 13, 2019

Gilead Sciences, Inc.

Foster City, CA 94404
USA

Gilead Sciences Canada, Inc.

Mississauga, ON L5N 2W3

ATRIPLA[®], BIKTARVY[®], ODEFSEY[®], DESCOVY[®], GENVOYA[®], STRIBILD[®], COMPLERA[®], EMTRIVA[®], TRUVADA[®], VIREAD[®], HEPSERA[®] and VEMLIDY[®] are trademarks of Gilead Sciences, Inc. or its related companies.

All other marks referenced herein are the property of their respective owners.

© 2019 Gilead Sciences, Inc. All rights reserved.



e181221-GS-006

HIGHLIGHTS OF PRESCRIBING INFORMATION

These highlights do not include all the information needed to use ODEFSEY safely and effectively. See full prescribing information for ODEFSEY.

ODEFSEY® (emtricitabine, rilpivirine, and tenofovir alafenamide) tablets, for oral use
Initial U.S. Approval: 2016

WARNING: POST TREATMENT ACUTE EXACERBATION OF HEPATITIS B

See full prescribing information for complete boxed warning. Severe acute exacerbations of hepatitis B have been reported in patients who are coinfecting with HIV-1 and HBV and have discontinued products containing emtricitabine (FTC) and/or tenofovir disoproxil fumarate (TDF), and may occur with discontinuation of ODEFSEY. Hepatic function should be monitored closely in these patients. If appropriate, anti-hepatitis B therapy may be warranted. (5.1)

RECENT MAJOR CHANGES

Dosage and Administration, Recommended Dosage (2.2)	12/2019
Dosage and Administration, Not Recommended in Patients with Severe Renal Impairment (2.4)	12/2019
Warnings and Precautions, New Onset or Worsening Renal Impairment (5.5)	12/2019
Warnings and Precautions, Immune Reconstitution Syndrome (5.8)	12/2019

INDICATIONS AND USAGE

ODEFSEY is a three-drug combination of emtricitabine (FTC) and tenofovir alafenamide (TAF), both HIV nucleoside analog reverse transcriptase inhibitors (NRTIs), and rilpivirine (RPV), a non-nucleoside reverse transcriptase inhibitor (NNRTI), and is indicated as a complete regimen for the treatment of HIV-1 infection in patients weighing at least 35kg as initial therapy in those with no antiretroviral treatment history with HIV-1 RNA less than or equal to 100,000 copies per mL; or to replace a stable antiretroviral regimen in those who are virologically-suppressed (HIV-1 RNA less than 50 copies per mL) for at least 6 months with no history of treatment failure and no known substitutions associated with resistance to the individual components of ODEFSEY. (1)

Limitations of Use:

- More rilpivirine-treated subjects with HIV-1 RNA greater than 100,000 copies/mL at the start of therapy experienced virologic failure (HIV-1 RNA \geq 50 copies/mL) compared to rilpivirine-treated subjects with HIV-1 RNA less than or equal to 100,000 copies/mL. (14.2, 14.3)

DOSAGE AND ADMINISTRATION

- Testing: Prior to or when initiating ODEFSEY, test for hepatitis B virus infection. Prior to or when initiating ODEFSEY, and during treatment on a clinically appropriate schedule, assess serum creatinine, estimated creatinine clearance, urine glucose, and urine protein in all patients. In patients with chronic kidney disease, also assess serum phosphorus (2.1)
- Recommended dosage: one tablet taken orally once daily with a meal. (2.2)
- For pregnant patients who are already on ODEFSEY prior to pregnancy and who are virologically suppressed (HIV-1 RNA less than 50 copies per mL), one tablet taken once daily may be continued. Lower exposures of rilpivirine were observed during pregnancy, therefore viral load should be monitored closely. (2.3)
- Renal impairment: ODEFSEY is not recommended in patients with estimated creatinine clearance of 15 to below 30 mL per minute, or below 15 mL per minute who are not receiving chronic hemodialysis. (2.4)

DOSAGE FORMS AND STRENGTHS

Tablets: 200 mg of FTC, 25 mg of RPV and 25 mg of TAF. (3)

CONTRAINDICATIONS

ODEFSEY is contraindicated when coadministered with drugs where significant decreases in RPV plasma concentrations may occur, which may result in loss of virologic response and possible resistance and cross-resistance. (4)

WARNINGS AND PRECAUTIONS

- Skin and Hypersensitivity Reactions: Severe skin and hypersensitivity reactions have been reported during postmarketing experience with RPV-containing regimens, including cases of Drug Reaction with Eosinophilia and Systemic Symptoms (DRESS). Immediately discontinue treatment if hypersensitivity or rash with systemic symptoms or elevations in hepatic serum biochemistries develops and closely monitor clinical status, including hepatic serum biochemistries. (5.2)
- Hepatotoxicity: Hepatic adverse events have been reported in patients receiving an RPV-containing regimen. Monitor liver-associated tests before and during treatment with ODEFSEY in patients with underlying hepatic disease or marked elevations in liver-associated tests. Also consider monitoring liver-associated tests in patients without risk factors. (5.3)
- Depressive disorders: Severe depressive disorders have been reported. Immediate medical evaluation is recommended for severe depressive disorders. (5.4)
- New onset or worsening renal impairment: Assessment of serum creatinine, estimated creatinine clearance, urine glucose, and urine protein when initiating ODEFSEY and during therapy on a clinically appropriate schedule in all patients. Also assess serum phosphorus in patients with chronic kidney disease. (5.5)
- Concomitant use of ODEFSEY with drugs with a known risk to prolong the QTc interval of the electrocardiogram may increase the risk of Torsade de Pointes. (5.6)
- Lactic acidosis/severe hepatomegaly with steatosis: Discontinue treatment in patients who develop symptoms or laboratory findings suggestive of lactic acidosis or pronounced hepatotoxicity. (5.7)
- Immune reconstitution syndrome: May necessitate further evaluation and treatment. (5.8)

ADVERSE REACTIONS

Most common adverse reactions (incidence greater than or equal to 2%, all grades) are headache and sleep disturbances. (6.1)

To report SUSPECTED ADVERSE REACTIONS, contact Gilead Sciences, Inc. at 1-800-GILEAD-5 or FDA at 1-800-FDA-1088 or www.fda.gov/medwatch.

DRUG INTERACTIONS

- ODEFSEY is a complete regimen for the treatment of HIV-1 infection; therefore, coadministration with other antiretroviral medications for the treatment of HIV-1 infection is not recommended. (7.1)
- Consult the Full Prescribing Information prior to and during treatment for important drug interactions. (4, 5.6, 7)

USE IN SPECIFIC POPULATIONS

- Pregnancy: Total rilpivirine exposures were generally lower during pregnancy compared to the postpartum period. (2.3, 8.1, 12.3)
- Lactation: Breastfeeding not recommended due to the potential for HIV-1 transmission. (8.2)
- Pediatrics: Not recommended for patients weighing less than 35 kg. (8.4)

See 17 for PATIENT COUNSELING INFORMATION and FDA-approved patient labeling.

Revised: 12/2019

FULL PRESCRIBING INFORMATION: CONTENTS***WARNING: POST TREATMENT ACUTE EXACERBATION OF HEPATITIS B****1 INDICATIONS AND USAGE****2 DOSAGE AND ADMINISTRATION**

- 2.1 Testing Prior to Initiation and During Treatment with ODEFSEY
- 2.2 Recommended Dosage
- 2.3 Recommended Dosage During Pregnancy
- 2.4 Not Recommended in Patients with Severe Renal Impairment

3 DOSAGE FORMS AND STRENGTHS**4 CONTRAINDICATIONS****5 WARNINGS AND PRECAUTIONS**

- 5.1 Severe Acute Exacerbation of Hepatitis B in Patients Coinfected with HIV-1 and HBV
- 5.2 Skin and Hypersensitivity Reactions
- 5.3 Hepatotoxicity
- 5.4 Depressive Disorders
- 5.5 New Onset or Worsening Renal Impairment
- 5.6 Risk of Adverse Reactions or Loss of Virologic Response Due to Drug Interactions
- 5.7 Lactic Acidosis/Severe Hepatomegaly with Steatosis
- 5.8 Immune Reconstitution Syndrome

6 ADVERSE REACTIONS

- 6.1 Clinical Trials Experience
- 6.2 Postmarketing Experience

7 DRUG INTERACTIONS

- 7.1 Not Recommended with Other Antiretroviral Medications
- 7.2 Drugs Inducing or Inhibiting CYP3A Enzymes
- 7.3 Drugs Inducing or Inhibiting P-glycoprotein
- 7.4 Drugs Increasing Gastric pH
- 7.5 QT Prolonging Drugs
- 7.6 Drugs Affecting Renal Function

7.7 Significant Drug Interactions

7.8 Drugs Without Clinically Significant Interactions with ODEFSEY

8 USE IN SPECIFIC POPULATIONS

- 8.1 Pregnancy
- 8.2 Lactation
- 8.4 Pediatric Use
- 8.5 Geriatric Use
- 8.6 Renal Impairment
- 8.7 Hepatic Impairment

10 OVERDOSAGE**11 DESCRIPTION****12 CLINICAL PHARMACOLOGY**

- 12.1 Mechanism of Action
- 12.2 Pharmacodynamics
- 12.3 Pharmacokinetics
- 12.4 Microbiology

13 NONCLINICAL TOXICOLOGY

- 13.1 Carcinogenesis, Mutagenesis, Impairment of Fertility
- 13.2 Animal Toxicology and/or Pharmacology

14 CLINICAL STUDIES

- 14.1 Clinical Trial Results in HIV-1 Virologically-Suppressed Subjects Who Switched to ODEFSEY
- 14.2 Clinical Trial Results for Adult Subjects with no Antiretroviral Treatment History and Adult Subjects with Renal Impairment for Components of ODEFSEY
- 14.3 Clinical Trial Results for Pediatric Subjects Aged 12 to Less than 18 Years Old with no Antiretroviral Treatment History for Components of ODEFSEY

16 HOW SUPPLIED/STORAGE AND HANDLING**17 PATIENT COUNSELING INFORMATION**

* Sections or subsections omitted from the full prescribing information are not listed.

FULL PRESCRIBING INFORMATION

WARNING: POST TREATMENT ACUTE EXACERBATION OF HEPATITIS B

Severe acute exacerbations of hepatitis B have been reported in patients who are coinfecting with HIV-1 and HBV and have discontinued products containing emtricitabine (FTC) and/or tenofovir disoproxil fumarate (TDF), and may occur with discontinuation of ODEFSEY.

Hepatic function should be monitored closely with both clinical and laboratory follow-up for at least several months in patients who are coinfecting with HIV-1 and HBV and discontinue ODEFSEY. If appropriate, anti-hepatitis B therapy may be warranted [see *Warnings and Precautions (5.1)*].

1 INDICATIONS AND USAGE

ODEFSEY is indicated as a complete regimen for the treatment of HIV-1 infection in adult and pediatric patients weighing at least 35 kg:

- as initial therapy in those with no antiretroviral treatment history with HIV-1 RNA less than or equal to 100,000 copies per mL or
- to replace a stable antiretroviral regimen in those who are virologically-suppressed (HIV-1 RNA less than 50 copies per mL) for at least 6 months with no history of treatment failure and no known substitutions associated with resistance to the individual components of ODEFSEY [see *Microbiology (12.4) and Clinical Studies (14)*].

Limitations of Use:

- More rilpivirine-treated subjects with no antiretroviral treatment history with HIV-1 RNA greater than 100,000 copies/mL at the start of therapy experienced virologic failure (HIV-1 RNA \geq 50 copies/mL) compared to rilpivirine-treated subjects with HIV-1 RNA less than or equal to 100,000 copies/mL [see *Clinical Studies (14.2, 14.3)*].

2 DOSAGE AND ADMINISTRATION

2.1 Testing Prior to Initiation and During Treatment with ODEFSEY

Prior to or when initiating ODEFSEY, test patients for hepatitis B virus infection [see *Warnings and Precautions (5.1)*].

Prior to or when initiating ODEFSEY, and during treatment with ODEFSEY, on a clinically appropriate schedule, assess serum creatinine, estimated creatinine clearance, urine glucose, and urine protein in all patients. In patients with chronic kidney disease, also assess serum phosphorus [see *Warnings and Precautions (5.5)*].

2.2 Recommended Dosage

ODEFSEY is a three-drug fixed dose combination product containing 200 mg of emtricitabine (FTC), 25 mg of rilpivirine (RPV), and 25 mg of tenofovir alafenamide (TAF). The recommended dosage of ODEFSEY is one tablet taken orally once daily with a meal in adults and pediatric patients with body weight at least 35 kg and creatinine clearance greater than or equal to 30 mL per minute [see *Use in Specific Populations* (8.6) and *Clinical Pharmacology* (12.3)].

2.3 Recommended Dosage During Pregnancy

For pregnant patients who are already on ODEFSEY prior to pregnancy and are virologically suppressed (HIV-1 RNA less than 50 copies per mL), one tablet of ODEFSEY taken once daily may be continued. Lower exposures of rilpivirine, a component of ODEFSEY, were observed during pregnancy, therefore viral load should be monitored closely [see *Use in Specific Populations* (8.1) and *Clinical Pharmacology* (12.3)].

2.4 Not Recommended in Patients with Severe Renal Impairment

ODEFSEY is not recommended in patients with:

- severe renal impairment (estimated creatinine clearance of 15 to below 30 mL per minute); or
- end stage renal disease (ESRD; estimated creatinine clearance below 15 mL per minute) who are not receiving chronic hemodialysis [see *Dosage and Administration* (2.2), *Warnings and Precautions* (5.5), and *Use in Specific Populations* (8.6)].

3 DOSAGE FORMS AND STRENGTHS

Each ODEFSEY tablet contains 200 mg of emtricitabine (FTC), 25 mg of rilpivirine (RPV) (equivalent to 27.5 mg of rilpivirine hydrochloride), and 25 mg of tenofovir alafenamide (TAF) (equivalent to 28 mg of tenofovir alafenamide fumarate).

The tablets are gray, capsule-shaped, film-coated and debossed with “GSI” on one side and “255” on the other side.

4 CONTRAINDICATIONS

ODEFSEY is contraindicated when coadministered with the following drugs; coadministration may result in loss of virologic response and possible resistance to ODEFSEY or to the class of NNRTIs [see *Warnings and Precautions* (5.6), *Drug Interactions* (7) and *Clinical Pharmacology* (12.3)]:

- Anticonvulsants: carbamazepine, oxcarbazepine, phenobarbital, phenytoin
- Antimycobacterials: rifampin, rifapentine

- Glucocorticoid (systemic): dexamethasone (more than a single-dose)
- Herbal Products: St. John's wort (*Hypericum perforatum*)
- Proton Pump Inhibitors: e.g., dexlansoprazole, esomeprazole, lansoprazole, omeprazole, pantoprazole, rabeprazole

5 WARNINGS AND PRECAUTIONS

5.1 Severe Acute Exacerbation of Hepatitis B in Patients Coinfected with HIV-1 and HBV

Test patients with HIV-1 for the presence of hepatitis B virus (HBV) before or when initiating antiretroviral therapy [see *Dosage and Administration* (2.1)].

Severe acute exacerbations of hepatitis B (e.g., liver decompensation and liver failure) have been reported in patients who are coinfecting with HIV-1 and HBV and have discontinued products containing FTC and/or TDF, and may occur with discontinuation of ODEFSEY. Patients coinfecting with HIV-1 and HBV who discontinue ODEFSEY should be closely monitored with both clinical and laboratory follow-up for at least several months after stopping treatment with ODEFSEY. If appropriate, anti-hepatitis B therapy may be warranted, especially in patients with advanced liver disease or cirrhosis, since post treatment exacerbation of hepatitis may lead to hepatic decompensation and liver failure.

5.2 Skin and Hypersensitivity Reactions

Severe skin and hypersensitivity reactions, including cases of Drug Reaction with Eosinophilia and Systemic Symptoms (DRESS), have been reported during postmarketing experience with RPV-containing regimens. While some skin reactions were accompanied by constitutional symptoms such as fever, other skin reactions were associated with organ dysfunction, including elevations in hepatic serum biochemistries. During Phase 3 clinical trials of RPV, treatment-related rashes with at least Grade 2 severity were reported in 1% of subjects. Overall, most rashes were Grade 1 or 2 and occurred in the first four to six weeks of therapy [see *Adverse Reactions* (6.2)].

Discontinue ODEFSEY immediately if signs or symptoms of severe skin or hypersensitivity reactions develop, including but not limited to, severe rash or rash accompanied by fever, blisters, mucosal involvement, conjunctivitis, facial edema, angioedema, hepatitis, or eosinophilia. Clinical status including laboratory parameters should be monitored and appropriate therapy should be initiated.

5.3 Hepatotoxicity

Hepatic adverse events have been reported in patients receiving an RPV-containing regimen. Patients with underlying hepatitis B or C virus infection, or marked elevations in liver-associated tests prior to treatment, may be at increased risk for worsening or development of liver-associated test elevations with use of ODEFSEY. A few cases of

hepatic toxicity have been reported in adult patients receiving an RPV-containing regimen who had no preexisting hepatic disease or other identifiable risk factors. Appropriate laboratory testing prior to initiating therapy and monitoring for hepatotoxicity during therapy with ODEFSEY is recommended in patients with underlying hepatic disease such as hepatitis B or C, or in patients with marked elevations in liver-associated tests prior to treatment initiation. Liver-associated test monitoring should also be considered for patients without preexisting hepatic dysfunction or other risk factors.

5.4 Depressive Disorders

Depressive disorders (including depressed mood, depression, dysphoria, major depression, mood altered, negative thoughts, suicide attempt, suicidal ideation) have been reported with RPV. Promptly evaluate patients with severe depressive symptoms to assess whether the symptoms are related to ODEFSEY, and to determine whether the risks of continued therapy outweigh the benefits.

In Phase 3 trials of RPV in adult subjects (N=1368) through 96 weeks, the incidence of depressive disorders (regardless of causality, severity) reported among RPV-treated subjects (n=686) was 9%. Most events were mild or moderate in severity. In RPV-treated subjects, the incidence of Grades 3 and 4 depressive disorders (regardless of causality) was 1%, the incidence of discontinuation due to depressive disorders was 1%, and suicidal ideation and suicide attempt was reported in 4 and 2 subjects, respectively.

During the Phase 2 trial in RPV-treated pediatric subjects 12 to less than 18 years of age (N=36), the incidence of depressive disorders (regardless of causality, severity) was 19% (7/36) through 48 weeks. Most events were mild or moderate in severity. The incidence of Grades 3 and 4 depressive disorders (regardless of causality) was 6% (2/36). None of the subjects discontinued due to depressive disorders. Suicidal ideation and suicide attempt were reported in 1 subject.

5.5 New Onset or Worsening Renal Impairment

Renal impairment, including cases of acute renal failure and Fanconi syndrome (renal tubular injury with severe hypophosphatemia), has been reported with the use of tenofovir prodrugs in both animal toxicology studies and human trials. In clinical trials of FTC+TAF with EVG+COBI, there have been no cases of Fanconi syndrome or proximal renal tubulopathy (PRT). In clinical trials of FTC+TAF with EVG+COBI in treatment-naïve subjects and in virologically-suppressed subjects switched to FTC+TAF with EVG+COBI with estimated creatinine clearance greater than 50 mL per minute, renal serious adverse events or discontinuations due to renal adverse reactions were encountered in less than 1% of participants treated with FTC+TAF with EVG+COBI. In a study of virologically-suppressed subjects with baseline estimated creatinine clearance between 30 and 69 mL per minute treated with FTC+TAF with EVG+COBI for a median duration of 43 weeks, FTC+TAF with EVG+COBI was permanently discontinued due to worsening renal function in two of 80 (3%) subjects with a baseline estimated creatinine clearance between 30 and 50 mL per minute [see *Adverse Reactions (6.1)*]. ODEFSEY is not recommended in patients with estimated creatinine clearance of 15 to below 30 mL per minute, or in patients

with estimated creatinine clearance below 15 mL per minute who are not receiving chronic hemodialysis.

Patients taking tenofovir prodrugs who have impaired renal function and those taking nephrotoxic agents, including nonsteroidal anti-inflammatory drugs are at increased risk of developing renal-related adverse reactions.

Prior to or when initiating ODEFSEY, and during treatment with ODEFSEY, on a clinically appropriate schedule, assess serum creatinine, estimated creatinine clearance, urine glucose and urine protein in all patients. In patients with chronic kidney disease, also assess serum phosphorus. Discontinue ODEFSEY in patients who develop clinically significant decreases in renal function or evidence of Fanconi syndrome.

5.6 Risk of Adverse Reactions or Loss of Virologic Response Due to Drug Interactions

The concomitant use of ODEFSEY and other drugs may result in potentially significant drug interactions, some of which may lead to *[see Contraindications (4), and Drug Interactions (7)]*:

- Loss of therapeutic effect of ODEFSEY and possible development of resistance due to reduced exposure of RPV.

In healthy subjects, higher than recommended doses of RPV (75 mg once daily and 300 mg once daily –3 and 12 times the recommended dosages in ODEFSEY, respectively) have been shown to prolong the QTc interval of the electrocardiogram. Consider alternatives to ODEFSEY when coadministered with a drug that is known to have a risk of Torsade de Pointes *[see Drug Interactions (7.2) and Clinical Pharmacology (12.2)]*.

See Table 3 for steps to prevent or manage these possible and known significant drug interactions, including dosing recommendations *[see Contraindications (4) and Drug Interactions (7)]*. Consider the potential for drug interactions prior to and during ODEFSEY therapy and review concomitant medications during ODEFSEY therapy.

5.7 Lactic Acidosis/Severe Hepatomegaly with Steatosis

Lactic acidosis and severe hepatomegaly with steatosis, including fatal cases, have been reported with the use of nucleoside analogs, including emtricitabine, a component of ODEFSEY, and tenofovir DF, another prodrug of tenofovir, alone or in combination with other antiretrovirals. Treatment with ODEFSEY should be suspended in any patient who develops clinical or laboratory findings suggestive of lactic acidosis or pronounced hepatotoxicity (which may include hepatomegaly and steatosis even in the absence of marked transaminase elevations).

5.8 Immune Reconstitution Syndrome

Immune reconstitution syndrome has been reported in patients treated with combination antiretroviral therapy, including FTC and RPV, both components of ODEFSEY. During the

initial phase of combination antiretroviral treatment, patients whose immune system responds may develop an inflammatory response to indolent or residual opportunistic infections [such as *Mycobacterium avium* infection, cytomegalovirus, *Pneumocystis jirovecii* pneumonia (PCP), or tuberculosis], which may necessitate further evaluation and treatment.

Autoimmune disorders (such as Graves' disease, polymyositis, Guillain-Barré syndrome, and autoimmune hepatitis) have also been reported to occur in the setting of immune reconstitution, however, the time to onset is more variable, and can occur many months after initiation of treatment.

6 ADVERSE REACTIONS

The following adverse reactions are discussed in other sections of the labeling:

- Severe Acute Exacerbations of Hepatitis B [see *Warnings and Precautions (5.1)*]
- Skin and Hypersensitivity Reactions [see *Warnings and Precautions (5.2)*]
- Hepatotoxicity [see *Warnings and Precautions (5.3)*]
- Depressive Disorders [see *Warnings and Precautions (5.4)*]
- New Onset or Worsening Renal Impairment [see *Warnings and Precautions (5.5)*]
- Lactic Acidosis/Severe Hepatomegaly with Steatosis [see *Warnings and Precautions (5.7)*]
- Immune Reconstitution Syndrome [see *Warnings and Precautions (5.8)*]

6.1 Clinical Trials Experience

Because clinical trials are conducted under widely varying conditions, adverse reaction rates observed in the clinical trials of a drug (or a drug given in various combinations with other concomitant therapy) cannot be directly compared to rates in the clinical trials of another drug (or drug given in the same or different combination therapy) and may not reflect the rates observed in practice.

Adverse Reactions in Clinical Trials of ODEFSEY in Virologically-Suppressed Adult Subjects with HIV-1 Infection

The safety of ODEFSEY in virologically-suppressed adults is based on Week 48 data from two randomized, double-blinded, active-controlled clinical trials, 1160 and 1216, that enrolled 1505 adult subjects who were virologically-suppressed for at least 6 months. Both trials were designed to compare switching to ODEFSEY to maintaining efavirenz/emtricitabine/tenofovir disoproxil fumarate (EFV/FTC/TDF) or emtricitabine/rilpivirine/tenofovir disoproxil fumarate (FTC/RPV/TDF) in Trials 1160 and 1216, respectively. A total of 754 subjects received one tablet of ODEFSEY daily [see *Clinical Studies (14.1)*].

The most common adverse reactions (all Grades) reported in at least 2% of subjects in the ODEFSEY group across Trials 1216 and 1160 were headache and sleep disturbances (Table 1). Over 98% of the adverse reactions in the ODEFSEY group were of mild to moderate intensity. The proportion of subjects who discontinued treatment with ODEFSEY due to adverse events, regardless of severity, was 2% compared to 1% for FTC/RPV/TDF and 2% for EFV/FTC/TDF.

Table 1 Adverse Reactions^a (All Grades) Reported in ≥1% of HIV-1 Infected Virologically-Suppressed Adults in Trial 1160 or Trial 1216 (Week 48 analysis)

Adverse Reaction	Trial 1160		Trial 1216	
	ODEFSEY (N=438)	EFV/FTC/TDF (N=437) ^b	ODEFSEY (N=316)	FTC/RPV/TDF (N=313) ^b
Headache	2%	1%	0	1%
Sleep Disturbances	2%	1%	0	<1%
Flatulence	1%	<1%	<1%	1%
Abnormal Dreams	1%	1%	0	2%
Diarrhea	1%	3%	1%	2%
Nausea	1%	1%	1%	1%

- Frequencies of adverse reactions are based on all adverse events attributed to study drugs by the investigator.
- Data from Trials 1160 and 1216 do not provide an adequate basis for comparison of adverse reaction incidences between ODEFSEY and the FTC/RPV/TDF and EFV/FTC/TDF groups.

Renal Laboratory Tests

In Trial 1216, the median baseline eGFR was 104 mL per minute for subjects who switched to ODEFSEY from FTC/RPV/TDF (N=316) and the mean serum creatinine decreased by 0.02 mg per dL from baseline to Week 48.

In Trial 1160, the median baseline eGFR was 110 mL per minute for subjects who switched to ODEFSEY from EFV/FTC/TDF (N=438), and the mean serum creatinine increased by 0.1 mg per dL from baseline to Week 48.

Bone Mineral Density Effects

Changes in BMD from baseline to Week 48 were assessed by dual-energy X-ray absorptiometry (DXA) in Trials 1216 and 1160.

In Trial 1216, mean bone mineral density (BMD) increased in subjects who switched to ODEFSEY (1.61% lumbar spine, 1.04% total hip) and remained stable or decreased in subjects who remained on FTC/RPV/TDF (0.08% lumbar spine, -0.25% total hip). BMD declines of 5% or greater at the lumbar spine were experienced by 1.7% of ODEFSEY subjects and 3.0% of FTC/RPV/TDF subjects. BMD declines of

7% or greater at the femoral neck were experienced by 0% of ODEFSEY subjects and 1.2% of FTC/RPV/TDF subjects.

In Trial 1160, mean BMD increased in subjects who switched to ODEFSEY (1.65% lumbar spine, 1.28% total hip) and decreased slightly in subjects who remained on EFV/FTC/TDF (-0.05% lumbar spine, -0.13% total hip). BMD declines of 5% or greater at the lumbar spine were experienced by 2.3% of ODEFSEY subjects and 4.9% of EFV/FTC/TDF subjects. BMD declines of 7% or greater at the femoral neck were experienced by 1.4% of ODEFSEY subjects and 3.3% of EFV/FTC/TDF subjects. The long-term clinical significance of these BMD changes is not known.

Serum Lipids

Changes from baseline in total cholesterol, HDL-cholesterol, LDL-cholesterol, triglycerides, and total cholesterol to HDL ratio for Trials 1216 and 1160 are presented in Table 2.

Table 2 Lipid Values, Mean Change from Baseline Reported in Subjects Receiving ODEFSEY, FTC/RPV/TDF and EFV/FTC/TDF in Trials 1216 and 1160 at 48 Weeks

	Trial 1216				Trial 1160			
	ODEFSEY N=316 [n=235]		FTC/RPV/TDF N=314 [n=245]		ODEFSEY N=438 [n=295]		EFV/FTC/TDF N=437 [n=308]	
	Baseline	Week 48	Baseline	Week 48	Baseline	Week 48	Baseline	Week 48
	mg/dL	Change ^{a,b}	mg/dL	Change ^{a,b}	mg/dL	Change ^{a,b}	mg/dL	Change ^{a,b}
Total Cholesterol (fasted)	176	+17	171	0	193	-7	192	-3
HDL-Cholesterol (fasted)	50	+3	48	0	56	-4	55	-2
LDL-Cholesterol (fasted)	111	+13	108	+1	118 ^c	-1 ^c	119	-1
Triglycerides (fasted)	116	+12	119	-9	139	-12	133	+3
Total Cholesterol to HDL Ratio	3.7	+0.2	3.8	+0.1	3.7	+0.2	3.8	0

- The change from baseline is the mean of within-subject changes from baseline for subjects with both baseline and Week 48 values.
- Subjects who received lipid-lowering agents during the treatment period were excluded.
- [n=296] for ODEFSEY group in Study 1160 for LDL-Cholesterol (fasted)

Adverse Reactions in Clinical Trials of RPV-Containing Regimens in Treatment-Naïve Adult Subjects with HIV-1 Infection

In pooled 96-week trials of antiretroviral treatment-naïve HIV-1 infected adult subjects, the most common adverse reactions in subjects treated with RPV+FTC/TDF (N=550) (incidence greater than or equal to 2%, Grades 2–4) were headache, depressive disorders, and insomnia. The proportion of subjects who discontinued treatment with RPV+FTC/TDF due to adverse reactions, regardless of severity, was 2%. The most common adverse reactions that led to discontinuation in this treatment group were psychiatric disorders (1.6%) and rash (0.2%). Although the safety profile was similar in virologically-suppressed adults with HIV-1 infection who were switched to RPV and other antiretroviral drugs, the frequency of adverse events increased by 20% (N=317).

Adverse Reactions in Clinical Trials of FTC+TAF with EVG+COBI in Treatment-Naïve Adult Subjects with HIV-1 Infection

In pooled 48-week trials of antiretroviral treatment-naïve HIV-1 infected adult subjects, the most common adverse reaction in subjects treated with FTC+TAF with EVG+COBI (N=866) (incidence greater than or equal to 10%, all grades) was nausea (10%). In this treatment group, 0.9% of subjects discontinued FTC+TAF with EVG+COBI due to adverse event [see *Clinical Studies (14)*]. Antiretroviral treatment-naïve adult subjects treated with FTC+TAF with EVG+COBI experienced mean increases of 30 mg/dL of total cholesterol, 15 mg/dL of LDL cholesterol, 7 mg/dL of HDL cholesterol and 29 mg/dL of triglycerides after 48 weeks of use.

Renal Laboratory Tests

In two 48-week trials in antiretroviral treatment-naïve HIV-1 infected adults treated with FTC+TAF with EVG+COBI (N=866) with a median baseline eGFR of 115 mL per minute, mean serum creatinine increased by 0.1 mg per dL from baseline to Week 48. In a 24-week trial in adults with renal impairment (baseline eGFR 30 to 69 mL per minute) who received FTC+TAF with EVG+COBI (N=248), mean serum creatinine was 1.5 mg per dL at both baseline and Week 24.

Bone Mineral Density Effects

In the pooled analysis of two 48-week trials of antiretroviral treatment-naïve HIV-1 infected adult subjects, bone mineral density (BMD) from baseline to Week 48 was assessed by dual-energy X-ray absorptiometry (DXA). Mean BMD decreased from baseline to Week 48 by -1.30% with FTC+TAF with EVG+COBI at the lumbar spine and -0.66% at the total hip. BMD declines of 5% or greater at the lumbar spine were experienced by 10% of FTC+TAF with EVG+COBI subjects. BMD declines of 7% or greater at the femoral neck were experienced by 7% of FTC+TAF with EVG+COBI subjects. The long-term clinical significance of these BMD changes is not known.

Adverse Reactions in Clinical Trials in Pediatric Subjects with HIV-1 Infection

In an open-label 48-week trial of 36 antiretroviral treatment-naïve HIV-1 infected pediatric subjects 12 to less than 18 years old (weighing at least 32 kg) treated with 25 mg per day of RPV and other antiretrovirals, the most common adverse reactions were headache (19%), depression (19%), somnolence (14%), nausea (11%), dizziness (8%), abdominal pain (8%), vomiting (6%) and rash (6%).

In a 24-week, open-label trial of 23 antiretroviral treatment-naïve HIV-1 infected pediatric subjects aged 12 to less than 18 years old (weighing at least 35 kg) who received FTC+TAF with EVG+COBI, the safety of this combination was similar to that of adults. Among these pediatric subjects, mean BMD increased from baseline to Week 24, +1.7% at the lumbar spine and +0.8% for the total body less head. Mean changes from baseline BMD Z-scores were -0.10 for lumbar spine and -0.11 for total body less head at Week 24. Two subjects had significant (greater than 4%) lumbar spine BMD loss at Week 24.

6.2 Postmarketing Experience

The following adverse reactions have been identified during postmarketing experience in patients receiving RPV or TAF-containing regimens. Because these reactions are reported voluntarily from a population of uncertain size, it is not always possible to reliably estimate their frequency or establish a causal relationship to drug exposure.

Rilpivirine:

Metabolism and Nutrition Disorders

Weight increased

Skin and Subcutaneous Tissue Disorders

Severe skin and hypersensitivity reactions including DRESS (Drug Reaction with Eosinophilia and Systemic Symptoms)

Renal and Urinary Disorders

Nephrotic syndrome

Tenofovir alafenamide:

Skin and Subcutaneous Tissue Disorders

Angioedema, urticaria, and rash

7 DRUG INTERACTIONS

7.1 Not Recommended with Other Antiretroviral Medications

Because ODEFSEY is a complete regimen, coadministration with other antiretroviral medications for the treatment of HIV-1 infection is not recommended.

7.2 Drugs Inducing or Inhibiting CYP3A Enzymes

RPV is primarily metabolized by CYP3A, and drugs that induce or inhibit CYP3A may affect the clearance of RPV [see *Clinical Pharmacology (12.3)*]. Coadministration of RPV and drugs that induce CYP3A may result in decreased plasma concentrations of RPV and loss of virologic response and possible resistance to RPV or to the class of NNRTIs [see *Contraindications (4)*, *Warnings and Precautions (5.6)*, and *Table 3*].

Coadministration of RPV and drugs that inhibit CYP3A may result in increased plasma concentrations of RPV and possible adverse events.

7.3 Drugs Inducing or Inhibiting P-glycoprotein

TAF, a component of ODEFSEY, is a substrate of P-gp, BCRP, OATP1B1, and OATP1B3. Drugs that strongly affect P-gp and BCRP activity may lead to changes in TAF absorption (see *Table 3*). Drugs that induce P-gp activity are expected to decrease the absorption of TAF, resulting in decreased plasma concentration of TAF, which may lead to loss of therapeutic effect of ODEFSEY and development of resistance. Coadministration of ODEFSEY with other drugs that inhibit P-gp and BCRP may increase the absorption and plasma concentration of TAF.

7.4 Drugs Increasing Gastric pH

Coadministration of RPV with drugs that increase gastric pH may decrease plasma concentrations of RPV and lead to loss of virologic response and possible resistance to RPV or to the class of NNRTIs. Use of RPV with proton pump inhibitors is contraindicated and use of RPV with H₂-receptor antagonists requires staggered administration [see *Contraindications (4)* and *Table 3*].

7.5 QT Prolonging Drugs

There is limited information available on the potential for a pharmacodynamic interaction between RPV and drugs that prolong the QTc interval. In a study of healthy subjects, higher than recommended doses of RPV, 75 mg once daily and 300 mg once daily (3 times and 12 times recommended daily dose in ODEFSEY) prolonged the QTc interval [see *Warnings and Precautions (5.6)* and *Clinical Pharmacology (12.2)*]. Consider alternative medications to ODEFSEY in patients taking a drug with a known risk of Torsade de Pointes.

7.6 Drugs Affecting Renal Function

Because FTC and tenofovir are primarily excreted by the kidneys by a combination of glomerular filtration and active tubular secretion, coadministration of ODEFSEY with drugs that reduce renal function or compete for active tubular secretion may increase concentrations of FTC, tenofovir, and other renally eliminated drugs and this may increase the risk of adverse reactions. Some examples of drugs that are eliminated by active tubular secretion include, but are not limited to, acyclovir, cidofovir, ganciclovir, valacyclovir,

valganciclovir, aminoglycosides (e.g., gentamicin), and high-dose or multiple NSAIDs [see *Warnings and Precautions (5.5)*].

7.7 Significant Drug Interactions

Table 3 provides a listing of established or potentially clinically significant drug interactions with recommended steps to prevent or manage the drug interaction (the table is not all inclusive). The drug interactions described are based on studies conducted with either ODEFSEY, the components of ODEFSEY (FTC, RPV and TAF) as individual agents, or are predicted drug interactions that may occur with ODEFSEY [see *Clinical Pharmacology (12.3), Tables 8-11*]. For list of contraindicated drugs, [see *Contraindications (4)*].

Table 3 Significant^a Drug Interactions

Concomitant Drug Class: Drug Name	Effect on Concentration^b	Clinical Comment
Antacids: antacids (e.g., aluminum, magnesium hydroxide, or calcium carbonate)	↔ RPV (antacids taken at least 2 hours before or at least 4 hours after RPV) ↓ RPV (concomitant intake)	Administer antacids at least 2 hours before or at least 4 hours after ODEFSEY.
Anticonvulsants: carbamazepine oxcarbazepine phenobarbital phenytoin	↓ RPV	Coadministration is contraindicated due to potential for loss of virologic response and development of resistance.
Antimycobacterials: rifampin rifapentine	↓ RPV	Coadministration is contraindicated due to potential for loss of virologic response and development of resistance.
Antimycobacterials: rifabutin	↓ RPV ^c ↓ TAF	Coadministration of ODEFSEY with rifabutin is not recommended.
Azole Antifungal Agents: fluconazole itraconazole ketoconazole posaconazole voriconazole	↑ RPV ^{c,d} ↑ TAF ↓ ketoconazole ^{c,d}	No dosage adjustment is required when ODEFSEY is coadministered with azole antifungal agents. Clinically monitor for breakthrough fungal infections when azole antifungals are coadministered with ODEFSEY.
Glucocorticoid (systemic): dexamethasone (more than a single dose)	↓ RPV	Coadministration is contraindicated due to potential for loss of virologic response and development of resistance.

Concomitant Drug Class: Drug Name	Effect on Concentration^b	Clinical Comment
H₂-Receptor Antagonists: cimetidine famotidine nizatidine ranitidine	↔ RPV ^{c,d} (famotidine taken 12 hours before RPV or 4 hours after RPV) ↓ RPV ^{c,d} (famotidine taken 2 hours before RPV)	Administer H ₂ -receptor antagonists at least 12 hours before or at least 4 hours after ODEFSEY.
Herbal Products: St. John's wort (<i>Hypericum perforatum</i>)	↓ RPV	Coadministration is contraindicated due to potential for loss of virologic response and development of resistance.
Macrolide or Ketolide Antibiotics: clarithromycin erythromycin telithromycin	↑ RPV ↔ clarithromycin ↔ erythromycin ↔ telithromycin	Where possible, alternatives such as azithromycin should be considered.
Narcotic Analgesics: methadone	↓ R(-) methadone ^c ↓ S(+) methadone ^c ↔ RPV ^c ↔ methadone ^c (when used with tenofovir)	No dosage adjustments are required when initiating coadministration of methadone with ODEFSEY. However, clinical monitoring is recommended, as methadone maintenance therapy may need to be adjusted in some patients.
Proton Pump Inhibitors: e.g., dexlansoprazole, esomeprazole, lansoprazole, omeprazole, pantoprazole, rabeprazole	↓ RPV	Coadministration is contraindicated due to potential for loss of virologic response and development of resistance.

- This table is not all inclusive.
- Increase=↑; Decrease=↓; No Effect=↔
- The interaction was evaluated in a clinical study. All other drug interactions shown are predicted.
- This interaction study has been performed with a dose higher than the recommended dose for RPV. The dosing recommendation is applicable to the recommended dose of RPV 25 mg once daily.

7.8 Drugs Without Clinically Significant Interactions with ODEFSEY

Based on drug interaction studies conducted with the fixed dose combination or components of ODEFSEY, no clinically significant drug interactions have been observed when ODEFSEY is combined with the following drugs: acetaminophen, atorvastatin, chlorzoxazone, digoxin, ethinyl estradiol, ledipasvir, metformin, midazolam, norethindrone, norgestimate, sildenafil, simeprevir, sofosbuvir, velpatasvir, and voxilaprevir.

8 USE IN SPECIFIC POPULATIONS

8.1 Pregnancy

Pregnancy Exposure Registry

There is a pregnancy exposure registry that monitors pregnancy outcomes in individuals exposed to ODEFSEY during pregnancy. Healthcare providers are encouraged to register patients by calling the Antiretroviral Pregnancy Registry (APR) at 1-800-258-4263.

Risk Summary

Available data from the APR show no increase in the risk of overall major birth defects with first trimester exposure for emtricitabine (FTC) or rilpivirine (RPV) compared with the background rate for major birth defects of 2.7% in a US reference population of the Metropolitan Atlanta Congenital Defects Program (MACDP) (*see Data*). There are insufficient tenofovir alafenamide (TAF) data from the APR to adequately assess the risk of major birth defects. In a clinical trial, total rilpivirine exposures were generally lower during pregnancy compared to the postpartum period [*see Clinical Pharmacology (12.3)*]. The rate of miscarriage for individual drugs is not reported in the APR. The estimated background rate of miscarriage in the clinically recognized pregnancies in the U.S. general population is 15-20%.

Based on the experience of HIV-1-infected pregnant individuals who completed a clinical trial through the postpartum period with an RPV-based regimen, no dose adjustments are required for pregnant patients who are already on a stable RPV-containing regimen prior to pregnancy and who are virologically suppressed (HIV-1 RNA less than 50 copies per mL). Lower exposures of RPV were observed during pregnancy, therefore viral load should be monitored closely [*see Data and Clinical Pharmacology (12.3)*].

In animal studies, no adverse developmental effects were observed when the components of ODEFSEY were administered separately during the period of organogenesis at exposures up to 60 and 108 times (mice and rabbits, respectively; FTC), 15 and 70 times (rats and rabbits, respectively; RPV) and equal to and 53 times (rats and rabbits, respectively; TAF) the exposure at the recommended daily dose of these components in ODEFSEY (*see Data*). Likewise, no adverse developmental effects were seen when FTC was administered to mice and RPV was administered to rats through lactation at exposures up to approximately 60 and 63 times, respectively, the exposure at the recommended daily dose of these components in ODEFSEY. No adverse effects were observed in the offspring when TDF was administered through lactation at tenofovir exposures of approximately 14 times the exposure at the recommended daily dosage of ODEFSEY.

Data

Human Data

Prospective reports from the APR of overall major birth defects in pregnancies exposed to drug components of ODEFSEY are compared with a U.S. background major birth defect rate. Methodological limitations of the APR include the use of MACDP as the external

comparator group. Limitations of using an external comparator include differences in methodology and populations, as well as confounding due to the underlying disease.

Emtricitabine: Based on prospective reports to the APR of exposures to FTC-containing regimens during pregnancy resulting in live births (including over 2,750 exposed in the first trimester and over 1,200 exposed in the second/third trimester), there was no increase in overall birth defects with FTC compared with the background birth defect rate of 2.7% in the U.S. reference population of the MACDP. The prevalence of birth defects in live births was 2.4% (95% CI: 1.9% to 3.1%) with first trimester exposure to FTC-containing regimens and 2.3% (95% CI: 1.5% to 3.3%) with second/third trimester exposure to FTC-containing regimens.

Rilpivirine: RPV in combination with a background regimen was evaluated in a clinical trial of 19 HIV-1 infected pregnant subjects during the second and third trimesters and postpartum. Each of the subjects were on an RPV-based regimen at the time of enrollment. Twelve subjects completed the trial through the postpartum period (6-12 weeks after delivery) and pregnancy outcomes are missing for six subjects. The exposure (C_{0h} and AUC) of total RPV was approximately 30 to 40% lower during pregnancy compared with postpartum (6 to 12 weeks). The protein binding of RPV was similar (>99%) during second trimester, third trimester, and postpartum period [see *Clinical Pharmacology* (12.3)]. One subject discontinued the trial following fetal death at 25 weeks gestation due to suspected premature rupture of membranes. Among the 12 subjects who were virologically suppressed at baseline (less than 50 copies/mL), virologic response was preserved in 10 subjects (83.3%) through the third trimester visit and in 9 subjects (75%) through the 6-12 week postpartum visit. Virologic outcomes during the third trimester visit were missing for two subjects who were withdrawn (one subject was nonadherent to the study drug and one subject withdrew consent). Among the 10 infants with HIV test results available, born to 10 HIV-infected pregnant subjects, all had test results that were negative for HIV-1 at the time of delivery and up to 16 weeks postpartum. All 10 infants received antiretroviral prophylactic treatment with zidovudine. RPV was well tolerated during pregnancy and postpartum. There were no new safety findings compared with the known safety profile of RPV in HIV-1-infected adults.

Based on prospective reports to the APR of over 450 exposures to RPV-containing regimens during pregnancy (including over 290 exposed in the first trimester and over 160 exposed in the second/third trimester), there was no significant increase in overall risk of major birth defects with RPV compared with the background rate of 2.7% for major birth defects in the U.S. reference population of the MACDP. The prevalence of major birth defects in live births was 1.0% (95% CI: 0.2% to 2.9%) with first trimester exposure to RPV-containing regimens and 1.2% (95% CI: 0.2% to 4.4%) with second/third trimester exposure to RPV-containing regimens.

Tenofovir Alafenamide: Based on prospective reports to the APR of 85 exposures to TAF-containing regimens during pregnancy (including 56 exposed in the first trimester and 29 exposed in the second/third trimester), there have been 3 birth defects with first trimester exposure to TAF-containing regimens.

Animal Data

Emtricitabine: FTC was administered orally to pregnant mice (250, 500, or 1000 mg/kg/day) and rabbits (100, 300, or 1000 mg/kg/day) through organogenesis (on gestation days 6 through 15, and 7 through 19, respectively). No significant toxicological effects were observed in embryo-fetal toxicity studies performed with FTC in mice at exposures (AUC) approximately 60 times higher and in rabbits at approximately 108 times higher than human exposures at the recommended daily dose. In a pre/postnatal development study with FTC, mice were administered doses up to 1000 mg/kg/day; no significant adverse effects directly related to drug were observed in the offspring exposed daily from before birth (*in utero*) through sexual maturity at daily exposures (AUC) of approximately 60-fold higher than human exposures at the recommended daily dose.

Rilpivirine: RPV was administered orally to pregnant rats (40, 120, or 400 mg/kg/day) and rabbits (5, 10, or 20 mg/kg/day) through organogenesis (on gestation days 6 through 17, and 6 through 19, respectively). No significant toxicological effects were observed in embryo-fetal toxicity studies performed with RPV in rats and rabbits at exposures 15 (rats) and 70 (rabbits) times higher than the exposure in humans at the recommended dose of 25 mg once daily. In a pre/postnatal development study with RPV, where rats were administered up to 400 mg/kg/day through lactation, no significant adverse effects directly related to drug were noted in the offspring.

Tenofovir Alafenamide: TAF was administered orally to pregnant rats (25, 100, or 250 mg/kg/day) and rabbits (10, 30, or 100 mg/kg/day) through organogenesis (on gestation days 6 through 17, and 7 through 20, respectively). No adverse embryo-fetal effects were observed in rats and rabbits at TAF exposures similar to (rats) and approximately 53 (rabbits) times higher than the exposure in humans at the recommended daily dose of ODEFSEY. TAF is rapidly converted to tenofovir; the observed tenofovir exposure in rats and rabbits were 59 (rats) and 93 (rabbits) times higher than human tenofovir exposures at the recommended daily doses. Since TAF is rapidly converted to tenofovir and a lower tenofovir exposure in rats and mice was observed after TAF administration compared to tenofovir disoproxil fumarate (TDF, another prodrug for tenofovir) administration, a pre/postnatal development study in rats was conducted only with TDF. Doses up to 600 mg/kg/day were administered through lactation, no adverse effects were observed in the offspring on gestation day 7 [and lactation day 20] at tenofovir exposures of approximately 14 [21] times higher than the exposures in humans at the recommended daily dose of ODEFSEY.

8.2 Lactation

Risk Summary

The Centers for Disease Control and Prevention recommend that HIV-infected mothers not breastfeed their infants, to avoid risking postnatal transmission of HIV.

Based on published data, emtricitabine has been shown to be present in human milk; it is unknown if rilpivirine (RPV) and tenofovir alafenamide (TAF) are present in human milk. RPV is present in rat milk and tenofovir has been shown to be present in the milk of lactating rats and rhesus monkeys after administration of TDF (see *Data*). It is unknown if TAF is present in animal milk.

It is not known if the components of ODEFSEY affect milk production or have effects on the breastfed infant. Because of the potential for (1) HIV transmission (in HIV-negative infants), (2) developing viral resistance (in HIV-positive infants), and (3) adverse reactions in a breastfed infant similar to those seen in adults, instruct mothers not to breastfeed if they are receiving ODEFSEY.

Data

Rilpivirine: In animals, no studies have been conducted to assess the excretion of RPV directly; however, RPV was measured in rat pups which were exposed through the milk of treated dams (dosed up to 400 mg/kg/day).

Tenofovir Alafenamide: Studies in rats and monkeys have demonstrated that tenofovir is excreted in milk. Tenofovir was excreted into the milk of lactating rats following oral administration of TDF (up to 600 mg/kg/day) at up to approximately 24% of the median plasma concentration in the highest dosed animals at lactation day 11. Tenofovir was excreted into the milk of lactating monkeys, following a single subcutaneous (30 mg/kg) dose of tenofovir, at concentrations up to approximately 4% of plasma concentration resulting in exposure (AUC) of approximately 20% of plasma exposure.

8.4 Pediatric Use

The efficacy and safety of ODEFSEY as a complete regimen for the treatment of HIV-1 infection was established in pediatric patients 12 years of age and older with body weight greater than or equal to 35 kg [see *Dosage and Administration (2.2)*]. Use of ODEFSEY in this age group is supported by adequate and well-controlled studies of RPV+FTC+TDF in adults with HIV-1 infection, adequate and well-controlled studies of FTC+TAF with EVG+COBI in adults with HIV-1 infection, and by the following pediatric studies [see *Clinical Studies (14)*]:

- 48-week open-label trial of 36 antiretroviral treatment-naïve HIV-1 infected pediatric subjects 12 to less than 18 years old weighing at least 32 kg treated with 25 mg per day of RPV and other antiretrovirals. The safety and efficacy of RPV administered with other antiretrovirals were similar to that of antiretroviral treatment-naïve HIV-1 infected adults on this regimen [see *Adverse Reactions (6.1)* and *Clinical Studies (14)*].
- 24-week open-label trial of 23 antiretroviral treatment-naïve HIV-1 infected pediatric

subjects 12 to less than 18 years old (weighing at least 35 kg) treated with FTC+TAF with EVG+COBI. The safety and efficacy of FTC+TAF with EVG+COBI were similar to that of antiretroviral treatment-naïve HIV-1 infected adults on this regimen [see *Adverse Reactions (6.1) and Clinical Studies (14)*].

Because it is a fixed-dose combination tablet, the dose of ODEFSEY cannot be adjusted for patients of lower age and weight. The safety and efficacy of ODEFSEY have not been established in pediatric patients weighing less than 35 kg [see *Clinical Pharmacology (12.3)*].

8.5 Geriatric Use

In clinical trials, 80 of the 97 subjects enrolled aged 65 years and over received FTC+TAF with EVG+COBI. No differences in safety or efficacy have been observed between elderly subjects and those between 12 and less than 65 years of age. Clinical trials of RPV did not include sufficient numbers of subjects aged 65 years and over to determine whether they respond differently from younger subjects [see *Clinical Pharmacology (12.3)*].

8.6 Renal Impairment

No dosage adjustment of ODEFSEY is recommended in patients with estimated creatinine clearance greater than or equal to 30 mL per minute. ODEFSEY should be used with caution in adults patients with ESRD (estimated creatinine clearance below 15mL per minute) who are receiving chronic hemodialysis and increased monitoring is recommended for RPV-related adverse effects in patients with ESRD, as RPV concentrations may be increased due to alteration of drug absorption, distribution, and metabolism secondary to renal dysfunction. On days of hemodialysis, administer the daily dose of ODEFSEY after completion of hemodialysis treatment [see *Dosage and Administration (2.4) and Clinical Pharmacology (12.3)*].

ODEFSEY is not recommended in patients with severe renal impairment (estimated creatinine clearance of 15 to below 30 mL per minute), or in patients with ESRD who are not receiving chronic hemodialysis, as the safety of ODEFSEY has not been established in these populations [see *Dosage and Administration (2.4) and Clinical Pharmacology (12.3)*].

8.7 Hepatic Impairment

No dosage adjustment of ODEFSEY is recommended in patients with mild (Child-Pugh Class A) or moderate (Child-Pugh Class B) hepatic impairment. ODEFSEY has not been studied in patients with severe hepatic impairment (Child-Pugh Class C) [see *Clinical Pharmacology (12.3)*].

10 OVERDOSAGE

Limited data are available on overdose of the components of ODEFSEY in patients. If overdose occurs, monitor the patient for evidence of toxicity. Treatment of overdose with

ODEFSEY consists of general supportive measures including monitoring of vital signs and ECG (QT interval) as well as observation of the clinical status of the patient.

Emtricitabine (FTC): Hemodialysis treatment removes approximately 30% of the FTC dose over a 3-hour dialysis period starting within 1.5 hours of FTC dosing (blood flow rate of 400 mL per minute and a dialysate flow rate of 600 mL per minute). It is not known whether FTC can be removed by peritoneal dialysis.

Rilpivirine (RPV): Human experience of overdose with RPV is limited. There is no specific antidote for overdose with RPV. Since RPV is highly bound to plasma protein, dialysis is unlikely to result in significant removal of RPV.

Tenofovir Alafenamide (TAF): Tenofovir is efficiently removed by hemodialysis with an extraction coefficient of approximately 54%.

11 DESCRIPTION

ODEFSEY (emtricitabine, rilpivirine, and tenofovir alafenamide) is a fixed-dose combination tablet containing emtricitabine (FTC), rilpivirine (RPV), and tenofovir alafenamide (TAF) for oral administration.

- FTC, a synthetic nucleoside analog of cytidine, is an HIV-1 nucleoside analog reverse transcriptase inhibitor (HIV-1 NRTI).
- RPV is an HIV-1 non-nucleoside reverse transcriptase inhibitor (NNRTI).
- TAF, an HIV-1 NRTI, is converted in vivo to tenofovir, an acyclic nucleoside phosphonate (nucleotide) analog of adenosine 5'-monophosphate.

Each tablet contains 200 mg of FTC, 25 mg of RPV (equivalent to 27.5 of rilpivirine hydrochloride) and 25 mg of TAF (equivalent to 28 mg of tenofovir alafenamide fumarate) and the following inactive ingredients: croscarmellose sodium, lactose monohydrate, magnesium stearate, microcrystalline cellulose, polysorbate 20, and povidone. The tablets are film-coated with a coating material containing iron oxide black, polyethylene glycol, polyvinyl alcohol, talc, and titanium dioxide.

Emtricitabine: The chemical name of FTC is 4-amino-5-fluoro-1-(2*R*-hydroxymethyl-1,3-oxathiolan-5*S*-yl)-(1*H*)-pyrimidin-2-one. FTC is the (-)-enantiomer of a thio analog of cytidine, which differs from other cytidine analogs in that it has a fluorine in the 5 position.

FTC has a molecular formula of C₈H₁₀FN₃O₃S and a molecular weight of 247.24 and has the following structural formula:

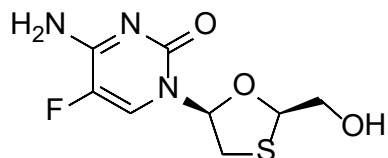

FTC is a white to off-white powder with a solubility of approximately 112 mg per mL in water at 25 °C.

Rilpivirine: The chemical name of rilpivirine hydrochloride drug substance is 4-[[4-[[4-[(E)-2-cyanoethenyl]-2,6-dimethylphenyl]amino]-2-pyrimidinyl]amino]benzotrile monohydrochloride. Its molecular formula is $C_{22}H_{18}N_6 \cdot HCl$ and its molecular weight is 402.88. Rilpivirine hydrochloride has the following structural formula:

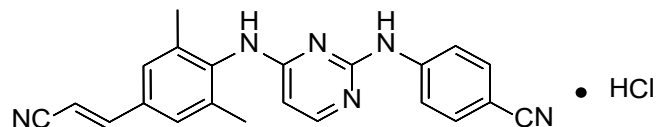

Rilpivirine hydrochloride is a white to almost white powder. Rilpivirine hydrochloride is practically insoluble in water over a wide pH range.

Tenofovir Alafenamide: The chemical name of tenofovir alafenamide fumarate drug substance is L-alanine, N-[(S)-[[[(1R)-2-(6-amino-9H-purin-9-yl)-1-methylethoxy]methyl]phenoxyphosphinyl]-, 1-methylethyl ester, (2E)-2-butenedioate (2:1).

Tenofovir alafenamide fumarate has an empirical formula of $C_{21}H_{29}O_5N_6P \cdot \frac{1}{2}(C_4H_4O_4)$ and a formula weight of 534.50 and has the following structural formula:

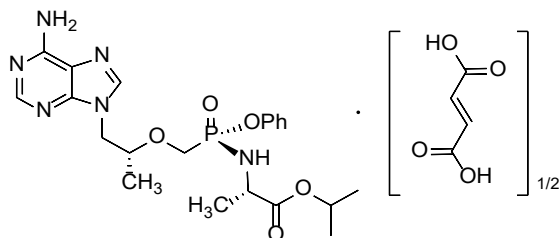

Tenofovir alafenamide fumarate is a white to off-white or tan powder with a solubility of 4.7 mg per mL in water at 20 °C.

12 CLINICAL PHARMACOLOGY

12.1 Mechanism of Action

ODEFSEY is a fixed dose combination of antiretroviral drugs emtricitabine, rilpivirine, and tenofovir alafenamide [see *Microbiology (12.4)*].

12.2 Pharmacodynamics

Cardiac Electrophysiology

When higher than recommended RPV doses of 75 mg (3 times the recommended dosage in ODEFSEY) once daily and 300 mg (12 times the recommended dosage in ODEFSEY) once daily were studied in healthy adults, the maximum mean time-matched (95% upper confidence bound) differences in QTcF interval from placebo after baseline correction were 10.7 (15.3) and 23.3 (28.4) milliseconds, respectively. Steady-state administration of RPV 75 mg once daily and 300 mg once daily resulted in a mean steady-state C_{max} approximately 2.6 times and 6.7 times, respectively, higher than the mean C_{max} observed

with the recommended 25 mg once daily dose of RPV [see *Warnings and Precautions (5.6)*].

The effect of RPV at the recommended dose of 25 mg once daily on the QTcF interval was evaluated in a randomized, placebo-, and active- (moxifloxacin 400 mg once daily) controlled crossover study in 60 healthy adults, with 13 measurements over 24 hours at steady state. The maximum mean time-matched (95% upper confidence bound) differences in QTcF interval from placebo after baseline correction was 2 (5) milliseconds (i.e., below the threshold of clinical concern).

In a thorough QT/QTc study in 48 healthy subjects, TAF at the recommended dose and at a dose approximately 5 times the recommended dose, did not affect the QT/QTc interval and did not prolong the PR interval.

The effect of FTC on the QT interval is not known.

12.3 Pharmacokinetics

Absorption, Distribution, Metabolism, and Excretion

The pharmacokinetic properties of the components of ODEFSEY are provided in Table 4. The multiple dose pharmacokinetic parameters of FTC, RPV and TAF and its metabolite tenofovir are provided in Table 5.

Table 4 Pharmacokinetic Properties of the Components of ODEFSEY

	Rilpivirine	Emtricitabine	Tenofovir Alafenamide
Absorption			
T _{max} (h)	4	3	1
Effect of moderate fat meal (relative to fasting) ^a	AUC Ratio = 1.13 (1.03, 1.23)	AUC Ratio = 0.91 (0.89, 0.93)	AUC Ratio = 1.45 (1.33, 1.58)
Effect of high fat meal (relative to fasting) ^a	AUC Ratio = 1.72 (1.49, 1.99)	AUC Ratio = 0.88 (0.85, 0.90)	AUC Ratio = 1.53 (1.39, 1.69)
Distribution			
% Bound to human plasma proteins	~99	<4	~80
Source of protein binding data	In vitro	In vitro	Ex vivo
Blood-to-plasma ratio	0.7	0.6	1.0
Metabolism			
Metabolism	CYP3A	Not significantly metabolized	Cathepsin A ^b (PBMCs) CES1 (hepatocytes) CYP3A (minimal)
Elimination			
Major route of elimination	Metabolism	Glomerular filtration and active tubular secretion	Metabolism (>80% of oral dose)
t _{1/2} (h) ^c	50	10	0.51
% Of dose excreted in urine ^d	6	70	<1
% Of dose excreted in feces ^d	85	13.7	31.7

PBMCs = peripheral blood mononuclear cells; CES1 = carboxylesterase 1.

a. Values refer to geometric mean ratio [fed/ fasted] in PK parameters and (90% confidence interval). High-calorie/high-fat meal = ~800 kcal, 50% fat. Moderate-fat meal = ~600 kcal, 27% fat.

b. In vivo, TAF is hydrolyzed within cells to form tenofovir (major metabolite), which is phosphorylated to the active metabolite, tenofovir diphosphate. In vitro studies have shown that TAF is metabolized to tenofovir by cathepsin A in PBMCs and macrophages; and by CES1 in hepatocytes. Upon coadministration with the moderate CYP3A inducer probe efavirenz, TAF exposure was unaffected.

c. t_{1/2} values refer to median terminal plasma half-life. Note that the pharmacologically active metabolite, tenofovir diphosphate, has a half-life of 150-180 hours within PBMCs.

d. Dosing in mass balance studies: FTC (single dose administration of [¹⁴C] emtricitabine after multiple dosing of emtricitabine for ten days); TAF (single dose administration of [¹⁴C] tenofovir alafenamide).

Table 5 Multiple Dose Pharmacokinetic Parameters of Emtricitabine, Rilpivirine, Tenofovir Alafenamide and its Metabolite Tenofovir Following Oral Administration with a Meal in HIV-Infected Adults

Parameter Mean (CV%)	Emtricitabine ^a	Rilpivirine ^b	Tenofovir Alafenamide ^c	Tenofovir ^d
C _{max} (microgram per mL)	2.1 (20.2)	NA	0.16 (51.1)	0.02 (26.1)
AUC _{tau} (microgram•hour per mL)	11.7 (16.6)	2.2 (38.1)	0.21 (71.8)	0.29 (27.4)
C _{trough} (microgram per mL)	0.10 (46.7)	0.08 (44.3)	NA	0.01 (28.5)

CV = Coefficient of Variation; NA = Not Applicable

a. From Intensive PK analysis in a phase 2 trial in HIV infected adults treated with FTC+TAF with EVG+COBI (n=19).

b. From Population PK analysis in a trial of treatment-naïve adults with HIV-1 infection treated with RPV (n=679).

c. From Population PK analysis in two trials of treatment-naïve adults with HIV-1 infection treated within EVG+COBI+FTC+TAF (n=539).

d. From Population PK analysis in two trials of treatment-naïve adults with HIV-1 infection treated with EVG+COBI+FTC+TAF (n=841).

Specific Populations

Geriatric Patients

The pharmacokinetics of FTC and TAF have not been fully evaluated in the elderly (65 years of age and older). Population pharmacokinetics analysis of HIV-infected subjects in Phase 2 and Phase 3 trials of FTC+TAF with EVG+COBI showed that age did not have a clinically relevant effect on exposures of TAF up to 75 years of age.

The pharmacokinetics of RPV have not been fully evaluated in the elderly (65 years of age and older) [see *Use in Specific Populations (8.5)*].

Pediatric Patients

Exposures of TAF in 24 pediatric subjects with HIV-1 infection aged 12 to less than 18 years who received FTC+TAF with EVG+COBI were decreased (23% for TAF AUC) compared to exposures achieved in treatment-naïve adults following administration of FTC+TAF with EVG+COBI. These exposure differences are not thought to be clinically significant based on exposure-response relationships. FTC exposures were similar in adolescents compared to treatment-naïve adults. The PK of RPV in antiretroviral HIV-1-infected pediatric subjects 12 to less than 18 years of age who received RPV 25 mg once daily were comparable to those in HIV-1 infected adults. As in adults, there was no impact of body weight on RPV PK in pediatric subjects [see *Use In Specific Populations (8.4)*].

Race and Gender

No clinically significant changes in the pharmacokinetics of the components of ODEFSEY have been observed based on race or gender.

Patients with Renal Impairment

Rilpivirine: Population pharmacokinetic analysis indicated that RPV exposure was similar in HIV-1 infected subjects with eGFR 60 to 89 mL per minute by Cockcroft-Gault method relative to HIV-1 infected subjects with normal renal function. There is limited or no information regarding the pharmacokinetics of RPV in patients with moderate or severe renal impairment or in patients with end-stage renal disease [see *Use in Specific Populations (8.6)*].

Emtricitabine and Tenofovir Alafenamide: The pharmacokinetics of FTC+TAF with EVG+COBI in HIV-1 infected subjects with renal impairment (eGFR 30 to 69 mL per minute by Cockcroft-Gault method), and in HIV-1 infected subjects with ESRD (estimated creatinine clearance of less than 15 mL per minute by Cockcroft-Gault method) receiving chronic hemodialysis were evaluated in subsets of virologically-suppressed subjects in open-label trials. The pharmacokinetics of TAF were similar among healthy subjects, subjects with mild or moderate renal impairment, and subjects with ESRD receiving chronic hemodialysis; increases in FTC and TFV exposures in subjects with renal impairment were not considered clinically relevant (Table 6).

Table 6 Pharmacokinetics of FTC and a Metabolite of TAF (Tenofovir) in HIV-Infected Adults with Renal Impairment as Compared to Subjects with Normal Renal Function

Estimated Creatinine Clearance ^a	AUC _{tau} (microgram-hour per mL) Mean (CV%)			
	≥90 mL per minute (N=18) ^b	60–89 mL per minute (N=11) ^c	30–59 mL per minute (N=18) ^d	<15 mL per minute (N=12) ^e
Emtricitabine	11.4 (11.9)	17.6 (18.2)	23.0 (23.6)	62.9 (48.0) ^f
Tenofovir	0.32 (14.9)	0.46 (31.5)	0.61 (28.4)	8.72 (39.4) ^g

a. By Cockcroft-Gault method.

b. From a phase 2 trial in HIV-infected adults with normal renal function treated with FTC+TAF with EVG+COBI.

c. These subjects had an eGFR ranging from 60 to 69 mL per minute.

d. From a phase 3 trial in HIV infected adults with renal impairment treated with FTC+TAF with EVG+COBI.

e. From a phase 3 trial in HIV infected adults with ESRD receiving chronic hemodialysis treated with FTC+TAF with EVG+COBI; PK assessed prior to hemodialysis following 3 consecutive daily doses of FTC+TAF with EVG+COBI.

f. N=11.

g. N=10.

Patients with Hepatic Impairment

Emtricitabine: The pharmacokinetics of FTC have not been studied in subjects with hepatic impairment; however, FTC is not significantly metabolized by liver enzymes, so the impact of hepatic impairment should be limited.

Rilpivirine: In a study comparing 8 subjects with mild hepatic impairment (Child-Pugh score A) to 8 matched controls and 8 subjects with moderate hepatic impairment (Child-Pugh score B) to 8 matched controls, the multiple-dose exposure of RPV was 47% higher in subjects with mild hepatic impairment and 5% higher in subjects with moderate hepatic impairment [see *Use in Specific Populations (8.7)*].

Tenofovir Alafenamide: Clinically relevant changes in the pharmacokinetics of tenofovir alafenamide or its metabolite tenofovir were not observed in subjects with mild, moderate, (Child-Pugh A and B) or severe hepatic impairment (Child-Pugh C) [see *Use in Specific Populations (8.7)*].

Hepatitis B and/or Hepatitis C Virus Coinfection

The pharmacokinetics of FTC and TAF have not been fully evaluated in subjects coinfecting with hepatitis B and/or C virus. Population pharmacokinetic analysis indicated that hepatitis B and/or C virus coinfection had no clinically relevant effect on the exposure of RPV.

Pregnancy and Postpartum

Rilpivirine: The exposure (C_{0h} and AUC_{24h}) to total RPV after intake of RPV 25 mg once daily as part of an antiretroviral regimen was 30 to 40% lower during pregnancy (similar for the second and third trimester), compared with postpartum (see Table 7). However, the exposure during pregnancy was not significantly different from exposures obtained in Phase 3 trials of RPV-containing regimens. Based on the exposure-response relationship for RPV, this decrease is not considered clinically relevant in patients who are virologically suppressed. The protein binding of RPV was similar (>99%) during the second trimester, third trimester, and postpartum.

Table 7 Pharmacokinetic Results of Total Rilpivirine After Administration of Rilpivirine 25 mg Once Daily as Part of an Antiretroviral Regimen, During the 2nd Trimester of Pregnancy, the 3rd Trimester of Pregnancy and Postpartum

Pharmacokinetics of total rilpivirine (mean ± SD, t _{max} : median [range])	Postpartum (6-12 Weeks) (n=11)	2nd Trimester of pregnancy (n=15)	3rd Trimester of pregnancy (n=13)
C _{0h} , ng/mL	111 ± 69.2	65.0 ± 23.9	63.5 ± 26.2
C _{min} , ng/mL	84.0 ± 58.8	54.3 ± 25.8	52.9 ± 24.4
C _{max} , ng/mL	167 ± 101	121 ± 45.9	123 ± 47.5
t _{max} , h	4.00 (2.03-25.08)	4.00 (1.00-9.00)	4.00 (2.00-24.93)
AUC _{24h} , ng.h/mL	2714 ± 1535	1792 ± 711	1762 ± 662

Drug Interaction Studies

Rilpivirine: RPV is primarily metabolized by CYP3A, and drugs that induce or inhibit CYP3A may thus affect the clearance of RPV.

RPV at a dose of 25 mg once daily is not likely to have a clinically relevant effect on the exposure of medicinal products metabolized by CYP enzymes.

TAF is not an inhibitor of CYP1A2, CYP2B6, CYP2C8, CYP2C9, CYP2C19, CYP2D6, or UGT1A1. TAF is a weak inhibitor of CYP3A in vitro. TAF is not an inhibitor or inducer of CYP3A in vivo.

The drug interaction studies described in Tables 8-11 were conducted with ODEFSEY (FTC/RPV/TAF) or the components of ODEFSEY (FTC, RPV, or TAF) administered individually.

The effects of coadministered drugs on the exposures of RPV and TAF are shown in Tables 8 and 9, respectively. The effects of RPV and TAF on the exposure of coadministered drugs are shown in Tables 10 and 11, respectively. For information regarding clinical recommendations, see *Drug Interactions (7)*.

Table 8 Changes in Pharmacokinetic Parameters for RPV in the Presence of Coadministered Drugs in Healthy Subjects

Coadministered Drug	Dose/Schedule		N	Mean Ratio of RPV Pharmacokinetic Parameters With/Without Coadministered Drug (90% CI); No Effect = 1.00		
	Coadministered Drug (mg)	RPV (mg)		C _{max}	AUC	C _{min}
Acetaminophen	500 single dose	150 once daily ^a	16	1.09 (1.01, 1.18)	1.16 (1.10, 1.22)	1.26 (1.16, 1.38)
Atorvastatin	40 once daily	150 once daily ^a	16	0.91 (0.79, 1.06)	0.90 (0.81, 0.99)	0.90 (0.84, 0.96)
Chlorzoxazone	500 single dose taken 2 hours after RPV	150 once daily ^a	16	1.17 (1.08, 1.27)	1.25 (1.16, 1.35)	1.18 (1.09, 1.28)
Ethinylestradiol/ Norethindrone	0.035 once daily /1 mg once daily	25 once daily ^b	15	↔ ^c	↔ ^c	↔ ^c
Famotidine	40 single dose taken 12 hours before RPV	150 single dose ^a	24	0.99 (0.84, 1.16)	0.91 (0.78, 1.07)	NA
Famotidine	40 single dose taken 2 hours before RPV	150 single dose ^a	23	0.15 (0.12, 0.19)	0.24 (0.20, 0.28)	NA
Famotidine	40 single dose taken 4 hours after RPV	150 single dose ^a	24	1.21 (1.06, 1.39)	1.13 (1.01, 1.27)	NA
Ketoconazole	400 once daily	150 once daily ^a	15	1.30 (1.13, 1.48)	1.49 (1.31, 1.70)	1.76 (1.57, 1.97)
Methadone	60-100 once daily, individualized dose	25 once daily ^b	12	↔ ^c	↔ ^c	↔ ^c
Ledipasvir/ Sofosbuvir	90/400 once daily	25 once daily ^d	42	0.97 (0.92, 1.02)	0.95 (0.91, 0.98)	0.93 (0.89, 0.97)
Omeprazole	20 once daily	25 single dose ^b	15	0.30 (0.24, 0.38)	0.35 (0.28, 0.44)	NA
Rifabutin	300 once daily	25 once daily ^b	18	0.69 (0.62, 0.76)	0.58 (0.52, 0.65)	0.52 (0.46, 0.59)
Rifampin	600 once daily	150 once daily ^a	16	0.31 (0.27, 0.36)	0.20 (0.18, 0.23)	0.11 (0.10, 0.13)

Coadministered Drug	Dose/Schedule		N	Mean Ratio of RPV Pharmacokinetic Parameters With/Without Coadministered Drug (90% CI); No Effect = 1.00		
	Coadministered Drug (mg)	RPV (mg)		C _{max}	AUC	C _{min}
Simeprevir	25 once daily	150 once daily ^b	23	1.04 (0.95, 1.30)	1.12 (1.05, 1.19)	1.25 (1.16, 1.35)
Sildenafil	50 single dose	75 once daily ^a	16	0.92 (0.85, 0.99)	0.98 (0.92, 1.05)	1.04 (0.98, 1.09)
Sofosbuvir/ velpatasvir	400/100 once daily	10 once daily ^e	24	0.93 (0.88, 0.98)	0.95 (0.90, 1.00)	0.96 (0.90, 1.03)
Sofosbuvir/velpatasvir/ voxilaprevir	400/100/100 + 100 voxilaprevir ^f once daily	25 once daily ^d	30	0.79 (0.74, 0.84)	0.80 (0.76, 0.85)	0.82 (0.77, 0.87)

CI=Confidence Interval; N=maximum number of subjects with data; NA=Not Available; ↔=no change

a. 25 mg, 75 mg, and 150 mg of RPV is 1, 3, and 6 times the recommended dose of RPV in ODEFSEY, respectively.

b. Study conducted with RPV.

c. Comparison based on historic controls.

d. Study conducted with ODEFSEY (FTC/RPV/TAF).

e. Study conducted with FTC/RPV/TDF.

f. Study conducted with additional voxilaprevir 100 mg to achieve voxilaprevir exposures expected in HCV-infected patients.

Table 9 Changes in Pharmacokinetic Parameters for TAF in the Presence of the Coadministered Drug^a in Healthy Subjects

Coadministered Drug	Dose of Coadministered Drug (mg)	TAF (mg)	N	Mean Ratio of Tenofovir Alafenamide Pharmacokinetic Parameters (90% CI); No Effect = 1.00		
				C _{max}	AUC	C _{min}
Cobicistat ^b	150 once daily	8 once daily	12	2.83 (2.20, 3.65)	2.65 (2.29, 3.07)	NA
Ledipasvir/ Sofosbuvir	90/400 once daily	25 once daily ^c	42	1.03 (0.94, 1.14)	1.32 (1.25, 1.40)	NA
Sofosbuvir/ velpatasvir/ voxilaprevir	400/100/100 + 100 voxilaprevir ^d once daily	25 once daily ^c	30	1.32 (1.17, 1.48)	1.52 (1.43, 1.61)	NA

CI=Confidence Interval; N=maximum number of subjects with data; NA=Not Available

a. All interaction studies conducted in healthy volunteers.

b. Increases TAF exposure via inhibition of intestinal P-glycoprotein.

c. Study conducted with ODEFSEY (FTC/RPV/TAF).

d. Study conducted with additional voxilaprevir 100 mg to achieve voxilaprevir exposures expected in HCV-infected patients.

Table 10 Changes in Pharmacokinetic Parameters for Coadministered Drugs in the Presence of RPV in Healthy Subjects

Coadministered Drug	Dose/Schedule		N	Mean Ratio of Coadministered Drug Pharmacokinetic Parameters With/Without RPV (90% CI); No Effect = 1.00		
	Coadministered Drug (mg)	RPV (mg)		C _{max}	AUC	C _{min}
Acetaminophen	500 single dose	150 once daily ^a	16	0.97 (0.86, 1.10)	0.92 (0.85, 0.99)	NA
Atorvastatin	40 once daily	150 once daily ^a	16	1.35 (1.08, 1.68)	1.04 (0.97, 1.12)	0.85 (0.69, 1.03)
2-hydroxy-atorvastatin				1.58 (1.33, 1.87)	1.39 (1.29, 1.50)	1.32 (1.10, 1.58)
4-hydroxy-atorvastatin				1.28 (1.15, 1.43)	1.23 (1.13, 1.33)	NA
Chlorzoxazone	500 single dose taken 2 hours after RPV	150 once daily ^a	16	0.98 (0.85, 1.13)	1.03 (0.95, 1.13)	NA
Digoxin	0.5 single dose	25 once daily ^b	22	1.06 (0.97, 1.17)	0.98 (0.93, 1.04) ^c	NA
Ethinylestradiol	0.035 once daily	25 once daily ^b	17	1.17 (1.06, 1.30)	1.14 (1.10, 1.19)	1.09 (1.03, 1.16)
Norethindrone	1 mg once daily			0.94 (0.83, 1.06)	0.89 (0.84, 0.94)	0.99 (0.90, 1.08)
Ketoconazole	400 once daily	150 once daily ^a	14	0.85 (0.80, 0.90)	0.76 (0.70, 0.82)	0.34 (0.25, 0.46)
Ledipasvir	90 once daily	25 once daily ^d	41	1.01 (0.97, 1.05)	1.02 (0.97, 1.06)	1.02 (0.98, 1.07)
Sofosbuvir	400 once daily	25 once daily ^d	41	0.96 (0.89, 1.04)	1.05 (1.01, 1.09)	NA
GS-331007 ^f				1.08 (1.05, 1.11)	1.08 (1.06, 1.10)	1.10 (1.07, 1.12)

Coadministered Drug	Dose/Schedule		N	Mean Ratio of Coadministered Drug Pharmacokinetic Parameters With/Without RPV (90% CI); No Effect = 1.00		
	Coadministered Drug (mg)	RPV (mg)		C _{max}	AUC	C _{min}
R(-) methadone S(+) methadone	60-100 once daily, individualized dose	25 once daily ^b	13	0.86 (0.78, 0.95)	0.84 (0.74, 0.95)	0.78 (0.67, 0.91)
				0.87 (0.78, 0.97)	0.84 (0.74, 0.96)	0.79 (0.67, 0.92)
Metformin	850 single dose	25 once daily ^b	20	1.02 (0.95, 1.10)	0.97 (0.90, 1.06) ^e	NA
Rifampin 25-desacetyl-rifampin	600 once daily	150 once daily ^a	16	1.02 (0.93, 1.12)	0.99 (0.92, 1.07)	NA
				1.00 (0.87, 1.15)	0.91 (0.77, 1.07)	NA
Simeprevir	150 once daily	25 once daily ^b	21	1.10 (0.97, 1.26)	1.06 (0.94, 1.19)	0.96 (0.83, 1.11)
Sildenafil N-desmethyl-sildenafil	50 single dose	75 once daily ^a	16	0.93 (0.80, 1.08)	0.97 (0.87, 1.08)	NA
				0.90 (0.80, 1.02)	0.92 (0.85, 0.99) ^c	NA
Sofosbuvir GS-331007 ^f	400 once daily	25 once daily ^g	24	1.09 (0.95, 1.25)	1.16 (1.10, 1.24)	NA
				0.96 (0.90, 1.01)	1.04 (1.00, 1.07)	1.12 (1.07, 1.17)
Velpatasvir	100 once daily	25 once daily ^g	24	0.96 (0.85, 1.10)	0.99 (0.88, 1.11)	1.02 (0.91, 1.15)
Sofosbuvir GS-331007 ^f	400 once daily	25 once daily ^d	30	0.95 (0.86, 1.05)	1.01 (0.97, 1.06)	NA
				1.02 (0.98, 1.06)	1.04 (1.01, 1.06)	NA
Velpatasvir	100 once daily	25 once daily ^d	30	1.05 (0.96, 1.16)	1.01 (0.94, 1.07)	1.01 (0.95, 1.09)
Voxilaprevir	100 + 100 once daily	25 once daily ^d	30	0.96 (0.84, 1.11)	0.94 (0.84, 1.05)	1.02 (0.92, 1.12)

CI=Confidence Interval; N=maximum number of subjects with data; NA=Not Available

a. 25 mg, 75 mg, and 150 mg of RPV is 1, 3, and 6 times the recommended dose of RPV in ODEFSEY, respectively.

b. Study conducted with RPV.

- c. $AUC_{(0-last)}$.
- d. Study conducted with ODEFSEY (FTC/RPV/TAF).
- e. N (maximum number of subjects with data for $AUC_{(0-\infty)}=15$)
- f. The predominant circulating nucleoside metabolite of sofosbuvir.
- g. Study conducted with FTC/RPV/TDF.

Table 11 Changes in Pharmacokinetic Parameters for Coadministered Drug in the Presence of TAF in Healthy Subjects

Coadministered Drug	Dose of Coadministered Drug (mg)	TAF (mg)	N	Mean Ratio of Coadministered Drug Pharmacokinetic Parameters (90% CI); No Effect = 1.00		
				C_{max}	AUC	C_{min}
Midazolam ^a	2.5 single dose, orally	25 once daily ^b	18	1.02 (0.92, 1.13)	1.13 (1.04, 1.23)	NA
	1 single dose, IV			0.99 (0.89, 1.11)	1.08 (1.04, 1.13)	NA
Ledipasvir ^c	90/400 once daily	25 once daily ^c	41	1.01 (0.97, 1.05)	1.02 (0.97, 1.06)	1.02 (0.98, 1.07)
Sofosbuvir ^c				0.96 (0.89, 1.04)	1.05 (1.01, 1.09)	NA
GS-331007 ^{c,d}				1.08 (1.05, 1.11)	1.08 (1.06, 1.10)	1.10 (1.07, 1.12)
Norelgestromin	norgestimate 0.180/0.215/0.250 once daily/ethinyl estradiol 0.025 once daily	25 once daily ^e	29	1.17 (1.07, 1.26)	1.12 (1.07, 1.17)	1.16 (1.08, 1.24)
Norgestrel				1.10 (1.02, 1.18)	1.09 (1.01, 1.18)	1.11 (1.03, 1.20)
Ethinyl estradiol				1.22 (1.15, 1.29)	1.11 (1.07, 1.16)	1.02 (0.93, 1.12)
Sofosbuvir	400 once daily	25 once daily ^c	30	0.95 (0.86, 1.05)	1.01 (0.97, 1.06)	NA
GS-331007 ^d				1.02 (0.98, 1.06)	1.04 (1.01, 1.06)	NA
Velpatasvir	100 once daily			1.05 (0.96, 1.16)	1.01 (0.94, 1.07)	1.01 (0.95, 1.09)
Voxilaprevir	100 + 100 once daily			0.96 (0.84, 1.11)	0.94 (0.84, 1.05)	1.02 (0.92, 1.12)

CI=Confidence Interval; N=maximum number of subjects with data; NA=Not Available

- a. A sensitive CYP3A4 substrate.
- b. Study conducted with TAF.
- c. Study conducted with ODEFSEY (FTC/RPV/TAF).
- d. The predominant circulating nucleoside metabolite of sofosbuvir.
- e. Study conducted with FTC/TAF.

12.4 Microbiology

Mechanism of Action

Emtricitabine: FTC, a synthetic nucleoside analog of cytidine, is phosphorylated by cellular enzymes to form emtricitabine 5'-triphosphate. Emtricitabine 5'-triphosphate inhibits the activity of the HIV-1 reverse transcriptase (RT) by competing with the natural substrate deoxycytidine 5'-triphosphate and by being incorporated into nascent viral DNA which results in chain termination. Emtricitabine 5'-triphosphate is a weak inhibitor of mammalian DNA polymerases α , β , ϵ , and mitochondrial DNA polymerase γ .

Rilpivirine: RPV is a diarylpyrimidine non-nucleoside reverse transcriptase inhibitor of HIV-1 and inhibits HIV-1 replication by non-competitive inhibition of HIV-1 RT. RPV does not inhibit the human cellular DNA polymerases α , β , and mitochondrial DNA polymerase γ .

Tenofovir Alafenamide: TAF is a phosphoramidate prodrug of tenofovir (2'-deoxyadenosine monophosphate analog). Plasma exposure to TAF allows for permeation into cells and then TAF is intracellularly converted to tenofovir through hydrolysis by cathepsin A. Tenofovir is subsequently phosphorylated by cellular kinases to the active metabolite tenofovir diphosphate. Tenofovir diphosphate inhibits HIV-1 replication through incorporation into viral DNA by the HIV reverse transcriptase, which results in DNA chain termination.

Tenofovir has activity against human immunodeficiency virus (HIV-1). Cell culture studies have shown that both tenofovir and FTC can be fully phosphorylated when combined in cells. Tenofovir diphosphate is a weak inhibitor of mammalian DNA polymerases that include mitochondrial DNA polymerase γ and there is no evidence of toxicity to mitochondria cell culture.

Antiviral Activity in Cell Culture

Emtricitabine, Rilpivirine, and Tenofovir Alafenamide: The combinations of FTC, RPV, and TAF were not antagonistic with each other in cell culture combination antiviral activity assays. In addition, FTC, RPV, and TAF were not antagonistic with a panel of representatives from the major classes of approved anti-HIV agents (NNRTIs, NRTIs, INSTIs, and PIs).

Emtricitabine: The antiviral activity of FTC against laboratory and clinical isolates of HIV-1 was assessed in T lymphoblastoid cell lines, the MAGI-CCR5 cell line, and primary peripheral blood mononuclear cells (PBMCs). The EC_{50} values for FTC were in the range of 0.0013–0.64 microM. FTC displayed antiviral activity in cell culture against HIV-1 clades A, B, C, D, E, F, and G (EC_{50} values ranged from 0.007–0.075 microM) and showed strain-specific activity against HIV-2 (EC_{50} values ranged from 0.007–1.5 microM).

Rilpivirine: RPV exhibited activity against laboratory strains of wild-type HIV-1 in an acutely infected T-cell line with a median EC_{50} value for HIV-1_{IIIB} of 0.73 nM. RPV demonstrated limited activity in cell culture against HIV-2 with a median EC_{50} value of 5220 nM (range 2510–10,830 nM). RPV demonstrated antiviral activity against a broad panel of HIV-1 group M (subtype A, B, C, D, F, G, H) primary isolates with EC_{50} values ranging from 0.07–

1.01 nM and was less active against group O primary isolates with EC₅₀ values ranging from 2.88–8.45 nM.

Tenofovir Alafenamide: The antiviral activity of TAF against laboratory and clinical isolates of HIV-1 subtype B was assessed in lymphoblastoid cell lines, PBMCs, primary monocyte/macrophage cells and CD4-T lymphocytes. The EC₅₀ values for TAF ranged from 2.0–14.7 nM.

TAF displayed antiviral activity in cell culture against all HIV-1 groups (M, N, O), including sub-types A, B, C, D, E, F, and G (EC₅₀ values ranged from 0.10–12.0 nM) and strain specific activity against HIV-2 (EC₅₀ values ranged from 0.91–2.63 nM).

Resistance

In Cell Culture

Emtricitabine: HIV-1 isolates with reduced susceptibility to FTC were selected in cell culture. Reduced susceptibility to FTC was associated with M184V or I substitutions in HIV-1 RT.

Rilpivirine: RPV-resistant strains were selected in cell culture starting from wild-type HIV-1 of different origins and subtypes as well as NNRTI-resistant HIV-1. The frequently observed amino acid substitutions that emerged and conferred decreased phenotypic susceptibility to RPV included: L100I, K101E, V106I and A, V108I, E138K and G, Q, R, V179F and I, Y181C and I, V189I, G190E, H221Y, F227C, and M230I and L.

Tenofovir Alafenamide: HIV-1 isolates with reduced susceptibility to TAF were selected in cell culture. HIV-1 isolates selected by TAF expressed a K65R substitution in HIV-1 RT, sometimes in the presence of S68N or L429I substitutions; in addition, a K70E substitution in HIV-1 RT was observed.

In Clinical Trials

In HIV-1-Infected Subjects With No Antiretroviral Treatment History

Emtricitabine and Tenofovir Alafenamide: The resistance profile of ODEFSEY for the treatment of HIV-1 infection is based on studies of FTC+TAF with EVG+COBI in the treatment of HIV-1 infection. In a pooled analysis of antiretroviral-naïve subjects, genotyping was performed on plasma HIV-1 isolates from all subjects with HIV-1 RNA greater than 400 copies per mL at confirmed virologic failure, at Week 48, or at time of early study drug discontinuation. Genotypic resistance developed in 7 of 14 evaluable subjects. The resistance-associated substitutions that emerged were M184V/I (N=7) and K65R (N=1). Three subjects had virus with emergent R, H, or E at the polymorphic Q207 residue in reverse transcriptase.

Rilpivirine: In the Week 96 pooled resistance analysis for adult subjects receiving RPV or efavirenz in combination with FTC/TDF, the emergence of resistance was greater among subjects' viruses in the RPV+FTC/TDF arm compared to the

efavirenz+FTC/TDF arm and was dependent on baseline viral load. In the Week 96 resistance analysis, 14% (77/550) of the subjects in the RPV+FTC/TDF arm and 8% (43/546) of the subjects in the efavirenz+FTC/TDF arm qualified for resistance analysis; 61% (47/77) of the subjects who qualified for resistance analysis (resistance-analysis subjects) in the RPV+FTC/TDF arm had virus with genotypic and/or phenotypic resistance to RPV compared to 42% (18/43) of the resistance-analysis subjects in the efavirenz+FTC/TDF arm who had genotypic and/or phenotypic resistance to efavirenz. Moreover, genotypic and/or phenotypic resistance to emtricitabine or tenofovir emerged in viruses from 57% (44/77) of the resistance-analysis subjects in the RPV arm compared to 26% (11/43) in the efavirenz arm.

Emerging NNRTI substitutions in the RPV resistance analysis of subjects' viruses included V90I, K101E/P/T, E138K/A/Q/G, V179I/L, Y181C/I, V189I, H221Y, F227C/L, and M230L, which were associated with an RPV phenotypic fold change range of 2.6–621. The E138K substitution emerged most frequently during RPV treatment, commonly in combination with the M184I substitution. The emtricitabine and lamivudine resistance-associated substitutions M184I or V and NRTI resistance-associated substitutions (K65R/N, A62V, D67N/G, K70E, Y115F, K219E/R) emerged more frequently in the RPV resistance-analysis subjects than in efavirenz resistance-analysis subjects.

NNRTI- and NRTI-resistance substitutions emerged less frequently in the resistance analysis of viruses from subjects with baseline viral loads of less than or equal to 100,000 copies/mL compared to viruses from subjects with baseline viral loads of greater than 100,000 copies/mL: 23% (10/44) compared to 77% (34/44) of NNRTI-resistance substitutions and 20% (9/44) compared to 80% (35/44) of NRTI-resistance substitutions. This difference was also observed for the individual emtricitabine/lamivudine and tenofovir resistance substitutions: 22% (9/41) compared to 78% (32/41) for M184I/V and 0% (0/8) compared to 100% (8/8) for K65R/N. Additionally, NNRTI and/or NRTI-resistance substitutions emerged less frequently in the resistance analysis of the viruses from subjects with baseline CD4+ cell counts greater than or equal to 200 cells/mm³ compared to the viruses from subjects with baseline CD4+ cell counts less than 200 cells/mm³: 32% (14/44) compared to 68% (30/44) of NNRTI-resistance substitutions and 27% (12/44) compared to 73% (32/44) of NRTI-resistance substitutions.

In Virologically-Suppressed Subjects

Emtricitabine and Tenofovir Alafenamide: One subject was identified with emergent resistance to FTC or TAF (M184M/I) out of 4 virologic failure subjects in a clinical study of virologically-suppressed subjects who switched from a regimen containing FTC+TDF to FTC+TAF with EVG+COBI (N=799).

Rilpivirine: Through Week 48, 4 subjects who switched their protease inhibitor-based regimen to FTC/RPV/TDF (4 of 469 subjects, 0.9%) and 1 subject who maintained their regimen (1 of 159 subjects, 0.6%) developed genotypic and/or phenotypic resistance to a study drug. All 4 of the subjects who had resistance emergence on

FTC/RPV/TDF had evidence of FTC resistance and 3 of the subjects had evidence of RPV resistance.

ODEFSEY: Through Week 48, in subjects who switched to ODEFSEY from FTC/RPV/TDF or EFV/FTC/TDF (Trials 1216 (N=316) and 1160 (N=438), respectively), of seven subjects who developed virologic failure, three subjects had detectable NNRTI and/or NRTI resistance substitutions at virologic failure that were pre-existing in the baseline sample by proviral DNA sequencing; one of these subjects resuppressed while maintaining ODEFSEY.

Cross-Resistance

Emtricitabine: FTC-resistant viruses with the M184V/I substitution were cross-resistant to lamivudine, but retained sensitivity to didanosine, stavudine, tenofovir, and zidovudine.

Viruses harboring substitutions conferring reduced susceptibility to stavudine and zidovudine—thymidine analog substitutions (M41L, D67N, K70R, L210W, T215Y/F, K219Q/E), or didanosine (L74V) remained sensitive to FTC. HIV-1 containing the K103N substitution or other substitutions associated with resistance to NNRTIs was susceptible to FTC.

Rilpivirine: Considering all of the available cell culture and clinical data, any of the following amino acid substitutions, when present at baseline, are likely to decrease the antiviral activity of RPV: K101E, K101P, E138A, E138G, E138K, E138R, E138Q, V179L, Y181C, Y181I, Y181V, Y188L, H221Y, F227C, M230I, M230L, and the combination of L100I+K103N.

Cross-resistance in site-directed mutant virus has been observed among NNRTIs. The single NNRTI substitutions K101P, Y181I, and Y181V conferred 52 times, 15 times, and 12 times decreased susceptibility to RPV, respectively. The combination of E138K and M184I showed 6.7 times reduced susceptibility to RPV compared to 2.8 times for E138K alone. The K103N substitution did not show reduced susceptibility to RPV by itself. However, the combination of K103N and L100I resulted in a 7 times reduced susceptibility to RPV. In another study, the Y188L substitution resulted in a reduced susceptibility to RPV of 9 times for clinical isolates and 6 times for site-directed mutants. Combinations of 2 or 3 NNRTI resistance-associated substitutions gave decreased susceptibility to RPV (fold change range of 3.7–554) in 38% and 66% of mutants, respectively.

Cross-resistance to efavirenz, etravirine, and/or nevirapine is likely after virologic failure and development of RPV resistance.

Tenofovir Alafenamide: Tenofovir resistance substitutions K65R and K70E result in reduced susceptibility to abacavir, didanosine, emtricitabine, lamivudine, and tenofovir.

HIV-1 with multiple thymidine analog substitutions (M41L, D67N, K70R, L210W, T215F/Y, K219Q/E/N/R), or multinucleoside resistant HIV-1 with a T69S double insertion mutation or with a Q151M substitution complex including K65R showed reduced susceptibility to TAF in cell culture.

13 NONCLINICAL TOXICOLOGY

13.1 Carcinogenesis, Mutagenesis, Impairment of Fertility

Emtricitabine: In long-term carcinogenicity studies of FTC, no drug-related increases in tumor incidence were found in mice at doses up to 750 mg per kg per day (23 times the human systemic exposure at the recommended dose of 200 mg per day in ODEFSEY) or in rats at doses up to 600 mg per kg per day (28 times the human systemic exposure at the recommended dose in ODEFSEY).

FTC was not genotoxic in the reverse mutation bacterial test (Ames test), mouse lymphoma or mouse micronucleus assays.

FTC did not affect fertility in male rats at approximately 140 times or in male and female mice at approximately 60 times higher exposures (AUC) than in humans given the recommended 200 mg daily dose in ODEFSEY. Fertility was normal in the offspring of mice exposed daily from before birth (in utero) through sexual maturity at daily exposures (AUC) of approximately 60 times higher than human exposures at the recommended 200 mg daily dose in ODEFSEY.

Rilpivirine: RPV was evaluated for carcinogenic potential by oral gavage administration to mice and rats up to 104 weeks. Daily doses of 20, 60, and 160 mg per kg per day were administered to mice and doses of 40, 200, 500, and 1500 mg per kg per day were administered to rats. In rats, there were no drug-related neoplasms. In mice, RPV was positive for hepatocellular neoplasms in both males and females. The observed hepatocellular findings in mice may be rodent-specific. At the lowest tested doses in the carcinogenicity studies, the systemic exposures (based on AUC) to RPV were 21 times (mice) and 3 times (rats) relative to those observed in humans at the recommended dose (25 mg once daily) in ODEFSEY.

RPV has tested negative in the absence and presence of a metabolic activation system, in the in vitro Ames reverse mutation assay and in vitro clastogenicity mouse lymphoma assay. RPV did not induce chromosomal damage in the in vivo micronucleus test in mice.

In a study conducted in rats, there were no effects on mating or fertility with RPV up to 400 mg per kg per day, a dose of RPV that showed maternal toxicity. This dose is associated with an exposure that is approximately 40 times higher than the exposure in humans at the recommended dose of 25 mg once daily in ODEFSEY.

Tenofovir Alafenamide: Since TAF is rapidly converted to tenofovir and a lower tenofovir exposure in rats and mice was observed after TAF administration compared to TDF administration, carcinogenicity studies were conducted only with TDF. Long-term oral carcinogenicity studies of TDF in mice and rats were carried out at exposures up to approximately 10 times (mice) and 4 times (rats) those observed in humans at the recommended dose of TDF (300 mg) for HIV-1 infection. The tenofovir exposure in these studies was approximately 167 times (mice) and 55 times (rat) those observed in humans after administration of the daily recommended dose of ODEFSEY. At the high dose in female mice, liver adenomas were increased at tenofovir exposures approximately 10 times

(300 mg TDF) and 167 times (ODEFSEY) the exposure observed in humans. In rats, the study was negative for carcinogenic findings.

TAF was not genotoxic in the reverse mutation bacterial test (Ames test), mouse lymphoma or rat micronucleus assays.

There were no effects on fertility, mating performance or early embryonic development when TAF was administered to male rats at a dose equivalent to 62 times the human dose based on body surface area comparisons for 28 days prior to mating and to female rats for 14 days prior to mating through Day 7 of gestation.

13.2 Animal Toxicology and/or Pharmacology

Minimal to slight infiltration of mononuclear cells in the posterior uvea was observed in dogs with similar severity after three- and nine-month administration of TAF; reversibility was seen after a three-month recovery period. No eye toxicity was observed in the dog at systemic exposures of 5 (TAF) and 15 (tenofovir) times the exposure seen in humans at the recommended daily TAF dose in ODEFSEY.

14 CLINICAL STUDIES

14.1 Clinical Trial Results in HIV-1 Virologically-Suppressed Subjects Who Switched to ODEFSEY

In Trial 1216, the efficacy and safety of switching from emtricitabine/rilpivirine/tenofovir disoproxil fumarate (FTC/RPV/TDF) to ODEFSEY were evaluated in a randomized, double-blind study of virologically-suppressed HIV-1 infected adults. Subjects were suppressed (HIV-1 RNA <50 copies/mL) on their baseline regimen of FTC/RPV/TDF for at least 6 months and have no documented resistance mutations to FTC, TAF, or RPV prior to study entry. Subjects were randomized in a 1:1 ratio to either switch to ODEFSEY (N=316) once daily or stay on FTC/RPV/TDF (N=314) once daily. Subjects had a mean age of 45 years (range: 23–72), 90% were male, 75% were White, and 19% were Black. The mean baseline CD4+ cell count was 709 cells/mm³ (range: 104–2527).

In Trial 1160, the efficacy and safety of switching from efavirenz/emtricitabine/tenofovir disoproxil fumarate (EFV/FTC/TDF) to ODEFSEY were evaluated in a randomized, double-blind study of virologically-suppressed HIV-1 infected adults. Subjects must have been stably suppressed (HIV-1 RNA <50 copies/mL) on their baseline regimen of EFV/FTC/TDF for at least 6 months and have no documented resistance mutations to FTC, TAF, or RPV prior to study entry. Subjects were randomized in a 1:1 ratio to either switch to ODEFSEY (N=438) once daily or stay on EFV/FTC/TDF (N=437) once daily. Subjects had a mean age of 48 years (range: 19–76), 87% were male, 67% were White, and 27% were Black. The mean baseline CD4+ cell count was 700 cells/mm³ (range: 140–1862).

Treatment outcomes of Trials 1216 and 1160 are presented in Table 12.

Table 12 Virologic Outcomes of Trials 1216 and 1160 at Week 48^a in Virologically-Suppressed Subjects who Switched to ODEFSEY

	Study 1216		Study 1160	
	ODEFSEY (N=316)	FTC/RPV/TDF (N=313) ^b	ODEFSEY (N=438)	EFV/FTC/TDF (N=437)
HIV-1 RNA <50 copies/mL	94%	94%	90%	92%
HIV-1 RNA ≥50 copies/mL^c	1%	0%	1%	1%
No Virologic Data at Week 48 Window	6%	6%	9%	7%
Discontinued Study Drug Due to AE or Death and Last Available HIV-1 RNA <50 copies/mL	2%	1%	3%	1%
Discontinued Study Drug Due to Other Reasons and Last Available HIV-1 RNA <50 copies/mL ^d	4%	4%	5%	5%
Missing Data During Window but on Study Drug	<1%	1%	1%	1%

- a. Week 48 window was between Day 295 and 378 (inclusive).
- b. One subject who was not on FTC/RPV/TDF prior to screening was excluded from the efficacy analysis.
- c. Included subjects who had HIV-1 RNA ≥50 copies/mL in the Week 48 window; subjects who discontinued early due to lack or loss of efficacy; subjects who discontinued for reasons other than lack or loss of efficacy and at the time of discontinuation had a viral value of ≥50 copies/mL.
- d. Includes subjects who discontinued for reasons other than an AE, death, or lack or loss of efficacy; e.g., withdrew consent, loss to follow-up, etc.

14.2 Clinical Trial Results for Adult Subjects with no Antiretroviral Treatment History and Adults with Renal Impairment for Components of ODEFSEY

The efficacy of RPV, FTC, and TAF in the treatment of HIV-1 infection in adults as initial therapy in those with no antiretroviral treatment history [see *Indications and Usage (1)*] was established in trials of:

- RPV+FTC/TDF in HIV-1 infected adults as initial therapy in those with no antiretroviral treatment history (n=550). The virologic response rate (i.e., HIV-1 RNA less than 50 copies per mL) was 77% at Week 96. The virologic response rate at 96 weeks was 83% in subjects with baseline HIV-1 RNA less than or equal to 100,000 copies per mL and 71% in subjects with baseline HIV-1 RNA greater than 100,000 copies per mL. Further, the virologic response rate at 96 weeks among subjects with baseline CD4+ cell counts less than 200 and greater than or equal to 200 cells/mm³ were 68% and 82%, respectively.
- FTC+TAF with EVG+COBI in HIV-1 infected adults as initial therapy in those with no antiretroviral treatment history (n=866). The virologic response rate (i.e., HIV-1 RNA less than 50 copies per mL) was 92% at Week 48.

In the clinical trial of 248 HIV-1 infected adults with estimated creatinine clearance greater than 30 mL per minute but less than 70 mL per minute, 95% (235/248) of the combined populations of treatment-naïve (N=6) begun on FTC+TAF with EVG+COBI and those previously virologically-suppressed on other regimens (N=242) and switched to FTC+TAF with EVG +COBI had HIV-1 RNA levels less than 50 copies per mL at Week 24.

14.3 Clinical Trial Results for Pediatric Subjects Aged 12 to Less than 18 Years Old with no Antiretroviral Treatment History for Components of ODEFSEY

The efficacy of RPV, FTC, and TAF in the treatment of HIV-1 infection in pediatric patients aged 12 to less than 18 years old and greater than 32-35 kg as initial therapy in those with no antiretroviral treatment history and to replace a stable antiretroviral regimen in those who are virologically-suppressed [see *Indications and Usage (1)*] was established in trials of antiretroviral treatment-naïve HIV-1 infected pediatric subjects 12 to less than 18 years old with:

- RPV in combination with other antiretroviral agents in 36 treatment-naïve HIV-1 infected adolescents weighing at least 32 kg. The majority of subjects (24/36) received RPV in combination with FTC and TDF. Of these 24 subjects, 20 had a baseline HIV-1 RNA less than or equal to 100,000 copies per mL. The virologic response rate in these 20 subjects (i.e., HIV-1 RNA less than 50 copies per mL) was 80% (16/20) at 48 weeks.
- FTC+TAF with EVG+COBI in 23 adolescents weighing at least 35 kg. The virologic response rate (i.e., HIV-1 RNA less than 50 copies per mL) was 91% at 24 weeks.

16 HOW SUPPLIED/STORAGE AND HANDLING

ODEFSEY tablets are gray, capsule-shaped, and film coated with “GSI” debossed on one side and “255” on the other side. Each bottle contains 30 tablets (NDC 61958-2101-1), a silica gel desiccant, and a polyester coil, and is closed with a child-resistant closure.

Store below 30°C (86°F).

- Keep container tightly closed.
- Dispense only in original container.

17 PATIENT COUNSELING INFORMATION

Advise the patient to read the FDA-approved patient labeling (Patient Information).

Post-treatment Acute Exacerbation of Hepatitis B in Patients with HBV Coinfection

Severe acute exacerbations of hepatitis B have been reported in patients who are coinfecting with HBV and HIV-1 and have discontinued products containing FTC and/or TDF, and may likewise occur with discontinuation of ODEFSEY [see *Warnings and Precautions (5.1)*]. Advise the patient to not discontinue ODEFSEY without first informing their healthcare provider.

Severe Skin Reactions and Hypersensitivity

Inform patients that skin reactions ranging from mild to severe, including Drug Reaction with Eosinophilia and Systemic Symptoms (DRESS), have been reported with RPV-containing products. Instruct patients to immediately stop taking ODEFSEY and seek medical attention if they develop a rash associated with any of the following symptoms: fever, blisters, mucosal involvement, eye inflammation (conjunctivitis), severe allergic reaction causing swelling of the face, eyes, lips, mouth, tongue or throat which may lead to difficulty swallowing or breathing, and any signs and symptoms of liver problems, as they may be a sign of a more serious reaction. Patients should understand that if severe rash occurs, they will be closely monitored, laboratory tests will be performed and appropriate therapy will be initiated [see *Warnings and Precautions (5.2)*].

Hepatotoxicity

Inform patients that hepatotoxicity has been reported with RPV, therefore, it is important to inform the healthcare professional if patients have underlying hepatitis B or C or elevations in liver-associated tests prior to treatment [see *Dosage and Administration (2.1)* and *Warnings and Precautions (5.3)*].

Depressive Disorders

Inform patients that depressive disorders (depressed mood, depression, dysphoria, major depression, mood altered, negative thoughts, suicide attempt, suicidal ideation) have been reported with RPV. Inform patients to seek immediate medical evaluation if they experience depressive symptoms [see *Warnings and Precautions (5.4)*].

New Onset or Worsening Renal Impairment

Advise patients to avoid taking ODEFSEY with concurrent or recent use of nephrotoxic agents. Renal impairment, including cases of acute renal failure, has been reported in association with the use of tenofovir prodrugs [see *Warnings and Precautions (5.5)*].

Drug Interactions

ODEFSEY may interact with many drugs and is not recommended to be coadministered with numerous drugs. Advise patients to report to their healthcare provider the use of any other prescription or nonprescription medication or herbal products, including St. John's wort [see *Contraindications (4)*, *Warnings and Precautions (5.6)* and *Drug Interactions (7)*].

Lactic Acidosis and Severe Hepatomegaly

Lactic acidosis and severe hepatomegaly with steatosis, including fatal cases, have been reported with use of drugs similar to ODEFSEY. Advise patients to stop taking ODEFSEY if they develop clinical symptoms suggestive of lactic acidosis or pronounced hepatotoxicity [see *Warnings and Precautions (5.7)*].

Immune Reconstitution Syndrome

Advise patients to inform their healthcare provider immediately of any symptoms of infection, as in some patients with advanced HIV infection (AIDS), signs and symptoms of inflammation from previous infections may occur soon after anti-HIV treatment is started [see *Warnings and Precautions (5.8)*].

Missed Dosage

Inform patients that it is important to take ODEFSEY on a regular dosing schedule with a meal and to avoid missing doses, as it can result in development of resistance [see *Dosage and Administration (2.2)*].

Pregnancy Registry

Inform patients that there is an antiretroviral pregnancy registry to monitor fetal outcomes in those exposed to ODEFSEY during pregnancy [see *Use in Specific Populations (8.1)*].

Lactation

Instruct patients with HIV-1 infection not to breastfeed because HIV-1 can be passed to the baby in breast milk [see *Use in Specific Populations (8.2)*].

ODEFSEY is a trademark of Gilead Sciences, Inc., or its related companies. All other trademarks referenced herein are the property of their respective owners.

Patient Information
ODEFSEY® (oh-DEF-see)
(emtricitabine, rilpivirine and tenofovir alafenamide)
tablets

Important: Ask your healthcare provider or pharmacist about medicines that should not be taken with ODEFSEY. For more information, see “**What should I tell my healthcare provider before taking ODEFSEY?**”

What is the most important information I should know about ODEFSEY?

ODEFSEY can cause serious side effects, including:

Worsening of Hepatitis B virus infection. If you have hepatitis B virus (HBV) infection and take ODEFSEY, your HBV may get worse (flare-up) if you stop taking ODEFSEY. A “flare-up” is when your HBV infection suddenly returns in a worse way than before.

- Do not run out of ODEFSEY. Refill your prescription or talk to your healthcare provider before your ODEFSEY is all gone.
- Do not stop taking ODEFSEY without first talking to your healthcare provider.
- If you stop taking ODEFSEY, your healthcare provider will need to check your health often and do blood tests regularly for several months to check your HBV infection. Tell your healthcare provider about any new or unusual symptoms you may have after you stop taking ODEFSEY.

For more information about side effects, see “**What are the possible side effects of ODEFSEY?**”

What is ODEFSEY?

ODEFSEY is a prescription medicine that is used to treat Human Immunodeficiency Virus-1 (HIV-1) in adults and children who weigh at least 77 pounds (35 kg):

- who have not received anti-HIV-1 medicines in the past and who have an amount of HIV-1 in their blood (this is called “viral load”) that is no more than 100,000 copies/mL, **or**
- to replace their current anti-HIV-1 medicines for people whose healthcare provider determines that they meet certain requirements.

HIV-1 is the virus that causes AIDS (Acquired Immune Deficiency Syndrome). ODEFSEY does not cure HIV-1 or AIDS.

ODEFSEY contains the prescription medicines emtricitabine, rilpivirine and tenofovir alafenamide.

It is not known if ODEFSEY is safe and effective in children under 12 years of age or who weigh less than 77 lb (35 kg).

Who should not take ODEFSEY?

Do not take ODEFSEY if you also take a medicine that contains:

- | | |
|-----------------------|---|
| • carbamazepine | • phenobarbital |
| • dexamethasone | • phenytoin |
| • dextansoprazole | • rabeprazole |
| • esomeprazole | • rifampin |
| • lansoprazole | • rifapentine |
| • omeprazole | • St. John’s wort (<i>Hypericum perforatum</i>) or a product that |
| • oxcarbazepine | contains St. John’s wort |
| • pantoprazole sodium | |

What should I tell my healthcare provider before taking ODEFSEY?

Before taking ODEFSEY, tell your healthcare provider about all your medical conditions, including if you:

- have liver problems, including hepatitis B or C virus infection
- have kidney problems

- have a history of depression or suicidal thoughts
- are pregnant or plan to become pregnant. It is not known if ODEFSEY can harm your unborn baby. Tell your healthcare provider if you become pregnant during treatment with ODEFSEY.

Pregnancy Registry: There is a pregnancy registry for those who take ODEFSEY during pregnancy. The purpose of this registry is to collect information about the health of you and your baby. Talk with your healthcare provider about how you can take part in this registry.

- are breastfeeding or plan to breastfeed. Do not breastfeed if you take ODEFSEY.
 - You should not breastfeed if you have HIV-1 because of the risk of passing HIV-1 to your baby.
 - At least one of the medicines in ODEFSEY can pass to your baby in your breast milk. It is not known if the other medicines in ODEFSEY can pass into your breast milk.

Talk with your healthcare provider about the best way to feed your baby during treatment with ODEFSEY.

Tell your healthcare provider about all the medicines you take, including prescription and over-the-counter medicines, vitamins, and herbal supplements.

Some medicines may interact with ODEFSEY. Keep a list of your medicines and show it to your healthcare provider and pharmacist when you get a new medicine.

- You can ask your healthcare provider or pharmacist for a list of medicines that interact with ODEFSEY.
- **Do not start a new medicine without telling your healthcare provider.** Your healthcare provider can tell you if it is safe to take ODEFSEY with other medicines.

How should I take ODEFSEY?

- Take ODEFSEY exactly as your healthcare provider tells you to take it. ODEFSEY is taken by itself (not with other HIV-1 medicines) to treat HIV-1 infection.
- Take ODEFSEY 1 time each day with a meal.
- If you are on dialysis, take your daily dose of ODEFSEY following dialysis.
- Do not change your dose or stop taking ODEFSEY without first talking with your healthcare provider. Stay under a healthcare provider's care during treatment with ODEFSEY.
- Do not miss a dose of ODEFSEY.
- When your ODEFSEY supply starts to run low, get more from your healthcare provider or pharmacy. This is very important because the amount of virus in your blood may increase if the medicine is stopped for even a short time. The virus may develop resistance to ODEFSEY and become harder to treat.
- If you take too much ODEFSEY, call your healthcare provider or go to the nearest hospital emergency room right away.

What are the possible side effects of ODEFSEY?

ODEFSEY may cause serious side effects, including:

- **See “What is the most important information I should know about ODEFSEY?”**

- **Severe skin rash and allergic reactions.** Skin rash is a common side effect of ODEFSEY. Rash can be serious. Call your healthcare provider right away if you get a rash. In some cases, rash and allergic reaction may need to be treated in a hospital.

If you get a rash with any of the following symptoms, stop taking ODEFSEY and call your healthcare provider or get medical help right away:

- fever
 - skin blisters
 - mouth sores
 - redness or swelling of the eyes (conjunctivitis)
 - swelling of the face, lips, mouth, or throat
 - trouble breathing or swallowing
 - pain on the right side of the stomach (abdominal) area
 - dark “tea colored” urine
- **Change in liver enzymes.** People with a history of hepatitis B or C virus infection or who have certain liver enzyme changes may have an increased risk of developing new or worsening liver problems during treatment with ODEFSEY. Liver problems can also happen during treatment with ODEFSEY in people without a history of liver disease. Your healthcare provider may need to do tests to check your liver enzymes before and during treatment with ODEFSEY.
 - **Depression or mood changes. Tell your healthcare provider right away if you have any of the following symptoms:**
 - feel sad or hopeless
 - feel anxious or restless
 - have thoughts of hurting yourself (suicide) or have tried to hurt yourself
 - **New or worse kidney problems, including kidney failure.** Your healthcare provider should do blood and urine tests to check your kidneys before you start and during treatment with ODEFSEY. Your healthcare provider may tell you to stop taking ODEFSEY if you develop new or worse kidney problems.
 - **Too much lactic acid in your blood (lactic acidosis).** Too much lactic acid is a serious but rare medical emergency that can lead to death. **Tell your healthcare provider right away if you get these symptoms:** weakness or being more tired than usual, unusual muscle pain, being short of breath or fast breathing, stomach pain with nausea and vomiting, cold or blue hands and feet, feel dizzy or lightheaded, or a fast or abnormal heartbeat.
 - **Severe liver problems.** In rare cases, severe liver problems can happen that can lead to death. **Tell your healthcare provider right away if you get these symptoms:** skin or the white part of your eyes turns yellow, dark “tea-colored” urine, light-colored stools, loss of appetite for several days or longer, nausea, or stomach-area pain.
 - **Changes in your immune system (Immune Reconstitution Syndrome)** can happen when you start taking HIV-1 medicines. Your immune system may get stronger and begin to fight infections that have been hidden in your body for a long time. Tell your healthcare provider right away if you start having any new symptoms after starting your HIV-1 medicine.

The most common side effects of ODEFSEY are headache and problems sleeping.

These are not all the possible side effects of ODEFSEY.

Call your doctor for medical advice about side effects. You may report side effects to FDA at 1-800-FDA-1088.

How should I store ODEFSEY?

- Store ODEFSEY below 86°F (30°C).
- Keep ODEFSEY in its original container.
- Keep the container tightly closed.

Keep ODEFSEY and all medicines out of reach of children.

General information about the safe and effective use of ODEFSEY.

Medicines are sometimes prescribed for purposes other than those listed in a Patient Information leaflet. Do not use ODEFSEY for a condition for which it was not prescribed. Do not give ODEFSEY to other people, even if they have the same symptoms you have. It may harm them. You can ask your healthcare provider or pharmacist for information about ODEFSEY that is written for health professionals.

For more information, call 1-800-445-3235 or go to www.ODEFSEY.com.

What are the ingredients in ODEFSEY?

Active ingredients: emtricitabine, rilpivirine, and tenofovir alafenamide.

Inactive ingredients: croscarmellose sodium, lactose monohydrate, magnesium stearate, microcrystalline cellulose, polysorbate 20, and povidone. The tablet film coating contains iron oxide black, polyethylene glycol, polyvinyl alcohol, talc, and titanium dioxide.

Manufactured and distributed by: Gilead Sciences, Inc. Foster City, CA 94404

ODEFSEY is a trademark of Gilead Sciences, Inc., or its related companies.

© 2019 Gilead Sciences, Inc. All rights reserved.

208351-GS-004

This Patient Information has been approved by the U.S. Food and Drug Administration

Revised: 12/2019

PRODUCT MONOGRAPH

Pr **OFEV**[®]

Nintedanib Capsules

100 mg and 150 mg nintedanib (as nintedanib esilate)

Protein Kinase Inhibitor

Anti-fibrotic/Anti-inflammatory Agent

Boehringer Ingelheim (Canada) Ltd.
5180 South Service Road
Burlington, ON L7L 5H4
www.boehringer-ingelheim.ca

Date of Preparation:

May 19, 2020

Submission Control No: 232923

BICL 0286-17

Ofev[®] is a registered trademark of Boehringer Ingelheim International GmbH, used under license

Table of Contents

PART I: HEALTH PROFESSIONAL INFORMATION.....	3
SUMMARY PRODUCT INFORMATION	3
INDICATIONS AND CLINICAL USE.....	3
CONTRAINDICATIONS	4
WARNINGS AND PRECAUTIONS.....	4
ADVERSE REACTIONS.....	10
DRUG INTERACTIONS	16
DOSAGE AND ADMINISTRATION	18
OVERDOSAGE	19
ACTION AND CLINICAL PHARMACOLOGY	20
STORAGE AND STABILITY.....	24
SPECIAL HANDLING INSTRUCTIONS	24
DOSAGE FORMS, COMPOSITION AND PACKAGING	24
PART II: SCIENTIFIC INFORMATION	25
PHARMACEUTICAL INFORMATION.....	25
CLINICAL TRIALS.....	26
DETAILED PHARMACOLOGY	37
TOXICOLOGY	37
REFERENCES	39
PART III: CONSUMER INFORMATION.....	40

OFEV®

Nintedanib Capsules

PART I: HEALTH PROFESSIONAL INFORMATION

SUMMARY PRODUCT INFORMATION

Route of Administration	Dosage Form / Strength	Clinically Relevant Nonmedicinal Ingredients
oral	Capsule 100 mg, 150 mg	Capsule fill: Medium chain triglycerides, hard fat, soya lecithin (E322) Capsule shell: Gelatin, glycerol 85 %, titanium dioxide (E171), iron oxide red (E172), iron oxide yellow (E172), black ink (Opacode®) Black ink: Shellac glaze, iron oxide black (E172), propylene glycol (E1520)

INDICATIONS AND CLINICAL USE

Idiopathic Pulmonary Fibrosis

OFEV (nintedanib) is indicated for the treatment of Idiopathic Pulmonary Fibrosis (IPF).

Systemic Sclerosis-Associated Interstitial Lung Disease

OFEV (nintedanib) is indicated to slow the rate of decline in pulmonary function in patients with systemic sclerosis associated interstitial lung disease (SSc-ILD).

Chronic Fibrosing Interstitial Lung Diseases with a Progressive Phenotype

OFEV (nintedanib) is indicated for the treatment of other chronic fibrosing interstitial lung diseases (ILDs) with a progressive phenotype (also known as progressive fibrosing ILD) (see [CLINICAL TRIALS](#)).

Geriatrics (> 65 years of age):

No dose adjustment is necessary in patients 65 years and older.

Pediatrics (< 18 years of age):

The safety and efficacy of OFEV in pediatric patients have not been studied in clinical trials and therefore, OFEV should not be used in patients under 18 years of age.

CONTRAINDICATIONS

- OFEV is contraindicated in patients with known hypersensitivity to nintedanib, peanut or soya, or any of the excipients (see [DOSAGE FORMS, COMPOSITION AND PACKAGING](#) section).
- OFEV is contraindicated during pregnancy (see [WARNINGS AND PRECAUTIONS, Special Populations, Pregnant Women](#) section).

WARNINGS AND PRECAUTIONS

General

Treatment should be initiated and supervised by physicians experienced in the diagnosis and treatment of conditions for which OFEV is indicated.

OFEV should be taken with food to reduce the incidence of gastrointestinal effects.

Physicians should monitor patients as frequently as clinically indicated for adverse reactions and according to the instructions of “[DOSAGE AND ADMINISTRATION](#)” and “[DRUG INTERACTIONS](#)”. For significant side effects, the treatment of symptoms and dose reduction or interruption of OFEV should be considered. Most adverse events with nintedanib occurred within the first 3 months of initiation and were managed with supportive treatment, dose reduction and/or treatment interruption.

Cardiovascular

Arterial thromboembolic events

Arterial thromboembolic events have been reported in patients taking OFEV.

In clinical trials in patients with IPF, in which patients with a recent history of myocardial infarction or stroke were excluded, arterial thromboembolic events were reported in 2.5% of patients treated with OFEV and 0.7% of placebo-treated patients. While adverse events reflecting ischaemic heart disease were balanced between the OFEV and placebo groups, a higher percentage of patients experienced myocardial infarctions in the OFEV group (1.6%) compared to the placebo group (0.5%) in the clinical trials.

In the clinical trial in patients with SSc-ILD and the clinical trial in patients with other chronic fibrosing ILDs with a progressive phenotype, no increased rates of arterial thromboembolic events or myocardial infarction were observed in patients treated with OFEV relative to patients treated with placebo. However, both of these trials excluded patients with significant pulmonary hypertension, and patients with a recent history of severe/uncontrolled hypertension, myocardial infarction, or unstable cardiac angina. Arterial thromboembolic events and myocardial infarction were reported in <1% of patients in each treatment group in both of these clinical trials.

Use caution when treating patients at higher cardiovascular risk including known coronary artery disease. Treatment interruption should be considered in patients who develop signs or symptoms of acute myocardial ischemia.

Venous thromboembolism

Based on the mechanism of action of nintedanib, patients might have potential for an increased risk of thromboembolic events. In the clinical trials, no increased risk of venous thromboembolism was observed in nintedanib treated patients.

Hypertension

Treatment with OFEV may increase blood pressure. In the clinical trial in patients with SSc-ILD hypertension was more common in the OFEV group (4.9%) than in the placebo group (1.7%). Systemic blood pressure should be measured periodically and as clinically indicated.

The use of VEGFR inhibitors may promote the formation of aneurysm and/or artery dissection. Serious cases of artery dissection have been reported in patients using VEGFR TKIs, including nintedanib. Before initiating OFEV, this risk should be carefully considered in patients with risk factors such as poorly controlled hypertension or a history of aneurysm.

Pulmonary Hypertension

In clinical trials of patients with SSc-ILD, patients with significant pulmonary hypertension were excluded from the study. Use OFEV in patients with clinically significant pulmonary hypertension only if the anticipated benefit outweighs the potential risk.

Endocrine and Metabolism

In clinical trials in patients with IPF, weight loss has been reported in 9.7% versus 3.5% of patients treated with OFEV and placebo, respectively. In the clinical trial in patients with other chronic fibrosing ILDs with a progressive phenotype, weight loss has been reported in 12% versus 3% of patients treated with OFEV and placebo, respectively. Physicians should monitor patients' weight, and when appropriate, encourage increased caloric intake if weight loss is considered to be of clinical significance.

Gastrointestinal

Diarrhea

In the clinical trials, diarrhea was the most frequent gastrointestinal event reported. In most patients, the event was of mild to moderate intensity and occurred within the first 3 months of treatment. In clinical trials in patients with IPF, diarrhea was reported in 62% versus 18% of patients treated with OFEV and placebo, respectively. Diarrhea led to permanent dose reduction in 11% of patients treated with OFEV compared to 0 placebo-treated patients. Diarrhea led to discontinuation in 5% of the patients treated with OFEV compared to less than 1% of placebo-treated patients (see [ADVERSE REACTIONS](#) section). In the clinical trial in patients with SSc-ILD, diarrhea was reported in 76% versus 32% of patients treated with OFEV and placebo, respectively. Diarrhea led to permanent dose reduction in 22% of patients treated with OFEV compared to 1% of placebo-treated patients. Diarrhea led to discontinuation in 7% of the patients

treated with OFEV compared to 0.3% of placebo-treated patients (see [ADVERSE REACTIONS](#) section). In the clinical trial in patients with other chronic fibrosing ILDs with a progressive phenotype, diarrhea was reported in 66.9% versus 23.9% of patients treated with OFEV and placebo, respectively. Diarrhea led to dose reduction in 16.0% of the patients treated with OFEV and 0.9% of patients treated with placebo; and to discontinuation in 5.7% of the patients treated with OFEV and 0.3% of patients treated with placebo (see [ADVERSE REACTIONS](#) section).

Diarrhea should be treated at first signs with adequate hydration and anti-diarrheal medication (e.g., loperamide) and may require dose reduction or treatment interruption. OFEV treatment may be resumed at a reduced dose (100 mg twice daily) or at the full recommended dose (150 mg twice daily). If severe diarrhea persists despite symptomatic treatment, treatment with OFEV should be discontinued.

Nausea and vomiting

Nausea and vomiting were frequently reported adverse events (see [ADVERSE REACTIONS](#) section). In most patients with nausea and vomiting, the event was of mild to moderate intensity. In clinical trials, nausea or vomiting infrequently led to discontinuation of treatment with nintedanib.

If symptoms persist despite appropriate supportive care (including anti-emetic therapy), dose reduction or treatment interruption may be required. The treatment may be resumed at a reduced dose (100 mg twice daily) or at the full recommended dose (150 mg twice daily). If severe nausea or vomiting persists despite symptomatic treatment, discontinue treatment with OFEV.

Diarrhea and vomiting may lead to dehydration -with or without electrolyte disturbances which may progress to renal function impairment.

Gastrointestinal perforations

Due to the mechanism of action of nintedanib, patients might have an increased risk of gastrointestinal perforation. In clinical trials in patients with IPF, gastrointestinal perforations were reported in 0.3% (2 cases, both serious) of patients treated with OFEV compared to 0 cases in placebo-treated patients. In the clinical trial in patients with SSc-ILD and the clinical trial in patients with other chronic fibrosing ILDs with a progressive phenotype, no gastrointestinal perforation was reported in patients treated with OFEV or in placebo-treated patients. Cases of gastrointestinal perforations have been reported in the post-marketing period, many of them were serious and some have resulted in fatal outcomes, although a definitive causal relationship to OFEV has not been established.

Particular caution should be exercised when treating patients with previous abdominal surgery, a recent history of hollow organ perforation, previous history of peptic ulceration, diverticular disease, or receiving concomitant corticosteroids or NSAIDs. OFEV should only be initiated at least 4 weeks after abdominal surgery. **Only use OFEV in patients with a known risk of gastrointestinal perforation if the anticipated benefit outweighs the potential risk. Therapy with OFEV should be permanently discontinued in patients who develop gastrointestinal perforation.**

Hemorrhage

Based on the mechanism of action of nintedanib, vascular endothelial growth factor receptor (VEGFR) inhibition, OFEV increases the risk of bleeding. Monitor patients on full anticoagulation therapy closely for bleeding and adjust anticoagulation treatment as necessary.

In clinical trials in patients with IPF, bleeding events were reported for 10% of patients treated with OFEV and in 8% of patients treated with placebo. In the clinical trial in patients with SSc-ILD, bleeding was reported in 11% of patients treated with OFEV and 8% of patients treated with placebo. In the clinical trial in patients with other chronic fibrosing ILDs with a progressive phenotype, bleeding events were reported in 11% of patients treated with OFEV and in 13% of patients treated with placebo. In clinical trials, non-serious epistaxis was the most frequent bleeding event reported. Most bleeding events were reported as non-serious. The most frequently reported bleeding AEs involved the respiratory and gastrointestinal systems such as epistaxis, and rectal bleeding. In clinical trials in patients with IPF, serious bleeding events occurred with low and similar frequencies in the 2 treatment groups (placebo: 1.4%; OFEV: 1.3%). In the clinical trial in patients with SSc-ILD, serious bleeding events occurred with low frequencies in both treatment groups (OFEV 1.4%, placebo 0.7%).

Serious and fatal bleeding events have been reported in clinical trials and post-marketing surveillance systems. **Use OFEV in patients with known risk of bleeding (e.g. patients with inherited predisposition to bleeding or patients receiving a full dose of anticoagulative treatment) only if the anticipated benefit outweighs the potential risk.**

Hepatic Function

The safety and efficacy of OFEV have not been studied in patients with moderate (Child Pugh B) or severe (Child Pugh C) hepatic impairment. Therefore, treatment with OFEV is not recommended in such patients (see [ACTION AND CLINICAL PHARMACOLOGY, Pharmacokinetics](#) section).

A pharmacokinetics study showed that both AUC and C_{max} were 2.2-fold higher in subjects with mild hepatic impairment (Child-Pugh A) (AUC: 90% CI: 1.2 – 3.8 and C_{max}: 90% CI: 1.3 – 3.7). Based on increased exposure, the risk for adverse events may be increased in patients with mild hepatic impairment (Child Pugh A group). Patients with mild hepatic impairment (Child Pugh A) should be treated with a reduced dose of OFEV (see [DOSAGE AND ADMINISTRATION](#) and [ACTION AND CLINICAL PHARMACOLOGY, Pharmacokinetics](#) section). However, this PK study showed that AUC was 8.7-fold (90% CI: 5.7 – 13.1) and C_{max} was 7.6-fold (90% CI: 4.4 – 13.2) higher in subjects with moderate hepatic impairment (Child-Pugh B group) when compared with the respective matched healthy subjects.

Drug-Induced Liver Injury (DILI)

Cases of drug-induced liver injury have been observed with nintedanib treatment in both clinical trials and post-marketing surveillance database. In the post-marketing period, non-serious and serious cases of drug-induced liver injury, including severe liver injury with fatal outcome, have been reported. In clinical trials in patients with IPF, drug-induced liver injury has been reported in 0.3% versus 0% of patients treated with OFEV and placebo, respectively. In the clinical trial

in patients with SSc-ILD, drug-induced liver injury has been reported with equal frequency (0.3%) in patients treated with OFEV and placebo. In the clinical trial in patients with other chronic fibrosing ILDs with a progressive phenotype, drug induced liver injury has been reported in 1.8% versus 0% of patients treated with nintedanib and placebo, respectively.

Liver Enzyme Elevations

In clinical trials, administration of nintedanib was associated with elevations of liver enzymes (ALT, AST, ALKP, GGT) and bilirubin. In the SSc-ILD trial, a maximum ALT and/or AST ≥ 3 x upper limit of normal (ULN) was observed for 4.9% of patients in the OFEV group and for 0.7% of patients in the placebo group.

Patients with low body weight (< 65 kg), Asian and female patients have a higher risk of elevations in liver enzymes. Nintedanib exposure increased linearly with patient age, which may also result in a higher risk of developing liver enzyme elevations. Close monitoring is recommended in patients with these risk factors.

Monitoring Liver Function

The majority of hepatic events occur within the first three months of treatment. In the majority of cases, elevations of liver enzymes (ALT, AST, ALKP, gamma-glutamyl-transferase (GGT)) and bilirubin were reversible upon dose reduction or treatment interruption. Therefore, hepatic transaminase and bilirubin levels should be investigated just before initiation of treatment with OFEV, then at regular intervals (monthly) during the first three months of treatment and periodically thereafter (e.g. at each patient visit) or as clinically indicated (see Monitoring and Laboratory Tests). Conduct liver tests promptly in patients who report symptoms that may indicate liver injury, including fatigue, anorexia, right upper abdominal discomfort, dark urine or jaundice. Dosage modifications or interruption may be necessary (see [DOSAGE AND ADMINISTRATION, Dose adjustments due to adverse reactions](#)).

Renal

Less than 1% of a single dose of nintedanib is excreted via the kidney (see [ACTION AND CLINICAL PHARMACOLOGY, Pharmacokinetics](#) section). Adjustment of the recommended dose (150 mg twice daily) in patients with mild to moderate renal impairment is not required. The safety, efficacy, and pharmacokinetics of nintedanib have not been studied in patients with severe renal impairment (<30 ml/min CrCL).

Wound healing complication

Based on the mechanism of action, nintedanib may impair wound healing. No increased frequency of impaired wound healing was observed in the clinical trials. No dedicated studies investigating the effect of nintedanib on wound healing were performed. Treatment with OFEV should therefore only be initiated or, in case of perioperative interruption, resumed based on clinical judgement of adequate wound healing.

Special Populations

Fertility

Based on preclinical investigations, there is no evidence for impairment of male fertility in rats (see [TOXICOLOGY](#) section). In rats, nintedanib reduced female fertility at exposure levels approximately 3 times the maximum recommended human dose (MRHD) of 150 mg twice daily (on an AUC basis at an oral dose of 100 mg/kg/day). Effects included increases in resorption and post-implantation loss, and a decrease in gestation index. Changes in the number and size of corpora lutea in the ovaries were observed in chronic toxicity studies in rats and mice. An increase in the number of females with resorptions was only observed at exposures approximately equal to the MRHD (on an AUC basis at an oral dose of 20 mg/kg/day (see [TOXICOLOGY](#) section).

Women of Childbearing Potential

OFEV may cause fetal harm (see [TOXICOLOGY](#) section) therefore, the use of OFEV is contraindicated during pregnancy. Women of childbearing potential should be advised to avoid becoming pregnant while receiving treatment with OFEV and to use highly effective contraceptive methods during OFEV treatment and for at least 3 months after the last dose of OFEV. It is currently unknown whether nintedanib may reduce the effectiveness of hormonal contraceptives; therefore women using hormonal contraceptives must add a barrier method.

Pregnant Women

Use of OFEV is contraindicated during pregnancy. OFEV may cause fetal harm when administered to pregnant women, therefore treatment with OFEV must not be initiated during pregnancy and pregnancy testing must be conducted prior to initiating treatment with OFEV and during treatment as appropriate. If the patient becomes pregnant while receiving OFEV, the treatment must be discontinued and the patient should be apprised of the potential hazard to the fetus.

Pre-clinical studies have shown that nintedanib is teratogenic and embryo-fetocidal in rats and rabbits (see [TOXICOLOGY](#) section). There is no information on the use of OFEV in pregnant women.

Nursing Women:

It is not known if nintedanib or its metabolites are excreted in human milk. Pre-clinical studies showed that small amounts of nintedanib and its metabolites (≤ 0.5 % of the administered dose) were secreted into milk of lactating rats.

Risk to the nursing infant cannot be excluded. A decision must be made whether to discontinue breast-feeding or to discontinue treatment with OFEV, taking into account the benefits of breast-feeding for the child and of OFEV treatment for the mother.

Pediatrics:

The safety and efficacy of OFEV in pediatric patients have not been studied in clinical trials. Toxicology studies in rodents showed hypertrophy of epiphyseal growth plates and abnormalities in growing incisors (see [TOXICOLOGY](#)). OFEV is not recommended for use in children and adolescents.

Geriatrics (>65 years of age):

No overall differences in safety and efficacy were observed for elderly patients compared to patients aged 65 years or younger. No adjustment of the recommended dose (150 mg twice daily) is required on the basis of a patient's age (see [ACTION AND CLINICAL PHARMACOLOGY, Pharmacokinetics](#) section).

Monitoring and Laboratory Tests

Hepatic transaminase and bilirubin levels should be investigated just before initiation of treatment with OFEV, then at regular intervals (monthly) during the first three months of treatment, periodically thereafter (e.g. at each patient visit) or as clinically indicated. Conduct liver tests promptly in patients who report symptoms that may indicate liver injury, including fatigue, anorexia, right upper abdominal discomfort, dark urine or jaundice. Dosage modifications or interruption may be necessary (See [WARNINGS AND PRECAUTIONS, Hepatic Function](#) section and [DOSAGE AND ADMINISTRATION](#) section).

ADVERSE REACTIONS

Adverse Drug Reaction Overview

Physicians should advise patients of the following potential adverse drug reactions:

- Liver Enzyme and Bilirubin Elevations
- Gastrointestinal Disorders
- Risk of Bleeding

Most gastrointestinal adverse events with nintedanib were managed with supportive treatment, dose reduction and/or treatment interruption. For the management of selected adverse reactions, please also refer to [WARNINGS AND PRECAUTIONS](#) section.

Clinical Trial Adverse Drug Reactions

Because clinical trials are conducted under very specific conditions the adverse reaction rates observed in the clinical trials may not reflect the rates observed in practice and should not be compared to the rates in the clinical trials of another drug. Adverse drug reaction information from clinical trials is useful for identifying drug-related adverse events and for approximating rates.

Nintedanib has been studied in clinical trials of 1529 patients suffering from IPF, 576 patients suffering from SSc-ILD and 663 patients with other chronic fibrosing ILDs with a progressive phenotype.

Idiopathic Pulmonary Fibrosis (IPF)

The following safety data are based on the two phase 3, randomized, double-blind, placebo-controlled studies in 1061 patients with IPF comparing treatment with nintedanib 150 mg twice daily to placebo for 52 weeks (1199.32 and 1199.34).

The most frequently reported adverse events associated with the use of nintedanib included

diarrhea, nausea and vomiting, abdominal pain, decreased appetite, weight decreased and hepatic enzyme increased. Serious adverse events were balanced between the treatment groups. Adverse events leading to discontinuation of study medication and permanent dose reduction were more frequent in the OFEV 150 mg bid group than in the placebo group. Common adverse events in 1199.32 and 1199.34, i.e. those that occurred in >3% of patients treated with nintedanib and more frequently than with placebo by $\geq 1.5\%$ are shown in Table 1.

Table 1 Adverse events occurring in >3% of patients treated with nintedanib and more frequently than with placebo by > 1.5%, by SOC and preferred term, sorted by frequency in the nintedanib 150 mg group in trials 1199.32 and 1199.34

System organ class/ Preferred term	Placebo N (%)	Nintedanib 150 mg bid N (%)
Patients	423 (100.0)	638 (100.0)
Patients with any AE	379 (89.6)	609 (95.5)
Gastrointestinal disorders		
Diarrhea	78 (18.4)	398 (62.4)
Nausea	28 (6.6)	156 (24.5)
Vomiting	11 (2.6)	74 (11.6)
Constipation	17 (4.0)	38 (6.0)
Abdominal pain ^a	26 (6.1)	96 (15.0)
Gastroesophageal reflux disease	10 (2.4)	31 (4.9)
Flatulence	4 (0.9)	30 (4.7)
Investigations		
Weight decreased ^d	15 (3.5)	62 (9.7)
Liver enzyme elevation ^b	11 (2.6)	87 (13.6)
Metabolism and nutrition disorders		
Decreased appetite	24 (5.7)	68 (10.7)
Nervous system disorders		
Headache	19 (4.5)	43 (6.7)
Vascular disorders		
Hypertension ^c	17 (4.0)	33 (5.2)

^a Includes abdominal pain, abdominal pain upper, abdominal pain lower, gastrointestinal pain and abdominal tenderness.

^b Includes gamma-glutamyltransferase increased, hepatic enzyme increased, alanine aminotransferase increased, aspartate aminotransferase increased, hepatic function abnormal, liver function test abnormal, transaminase increased, blood alkaline phosphatase-increased, alanine aminotransferase abnormal, aspartate aminotransferase abnormal, and gamma glutamyltransferase

abnormal.

^c Includes hypertension, blood pressure increased, hypertensive crisis, and hypertensive cardiomyopathy

^d Weight decreased is equivalent to weight loss.

Adverse Events Leading to Discontinuation of Study Medication in trials 1199.32 and 1199.34

Adverse events leading to discontinuation of study medication were more frequent in the nintedanib 150 mg bid group (19%) than in the placebo group (13%). Adverse events leading to discontinuation that were more common in the nintedanib than the placebo group by at least 1% were diarrhea (nintedanib 4.4%, placebo 0.2%), nausea (nintedanib 2.0%, placebo 0%) and decreased appetite (nintedanib 1.4%, placebo 0.2%).

Adverse Events Leading to Permanent Dose Reduction in trials 1199.32 and 1199.34

Adverse events leading to permanent dose reduction were reported for 16% of patients treated with OFEV compared to 2 patients (0.5%) treated with placebo. The most frequent adverse reaction that led to dose reduction was diarrhea (11%) followed by nausea (1.7%), vomiting (1.1%) and abdominal pain (0.9%). Other adverse events leading to dose reduction that occurred in more than 0.5% of patients were hepatic function abnormal (0.6%), weight decreased (0.6%) and decreased appetite (0.6%).

Serious Adverse Events

Serious adverse events were balanced between the treatment groups (nintedanib: 30.4%, placebo: 30.0%). The most frequent serious adverse events that were reported more frequently with OFEV compared to placebo were bronchitis (nintedanib: 1.3%, placebo: 0.5%) and myocardial infarction (nintedanib: 1.6%, placebo: 0.5%). The most common adverse events leading to death in patients treated with OFEV, more than placebo, were pneumonia (0.8% vs. 0.5%), lung neoplasm malignant (0.3% vs. 0%), and myocardial infarction (MI) (0.3% vs. 0.2%). In the predefined category of major adverse cardiovascular events (MACE) including MI, fatal events were reported in 0.6% of OFEV treated patients and 1.4% of placebo-treated patients.

Less Common Clinical Trial Adverse Drug Reactions (<3%) in trials 1199.32 and 1199.34

Adverse drug reactions occurring in <3% of patients treated with OFEV and more than placebo in trials 1199.32 and 1199.34 are listed below:

Hepatobiliary Disorders: hyperbilirubinemia

Skin and subcutaneous tissue disorders: alopecia (studies in patients with IPF: 1%)

Systemic Sclerosis associated Interstitial Lung Disease (SSc-ILD)

The following safety data are based on the a phase 3, randomized, double-blind, placebo-controlled study in 576 patients with SSc-ILD comparing treatment with OFEV 150 mg twice daily to placebo for at least 52 weeks (1199.214). Individual patients were treated for up to 100 weeks.

Adverse Events Leading to Discontinuation of Study Medication in trial 1199.214

Adverse reactions leading to discontinuation were reported in 16% of OFEV-treated patients and 9% of placebo-treated patients. The most frequent adverse reactions that led to discontinuation in

OFEV-treated patients were diarrhea (6.9% OFEV vs. 0.3% placebo), nausea (2.1% OFEV vs. 0 placebo), vomiting (1.4% OFEV vs. 0.3% placebo), and abdominal pain (1% OFEV vs. 0.3% placebo).

Adverse Events Leading to Permanent Dose Reduction in trial 1199.214

Adverse reactions leading to permanent dose reductions were reported in 34% of OFEV-treated patients and 4% of placebo-treated patients. The most frequent adverse reaction that led to permanent dose reduction in the patients treated with OFEV was diarrhea (22.2% OFEV vs. 1.0% placebo), nausea (2.1% OFEV vs. 0 placebo), vomiting (2.1% OFEV vs. 0 placebo), and alanine aminotransferase increased (1.4% OFEV vs. 0 placebo). All reactions were reversible after dose reduction or discontinuation.

Serious Adverse Events

The most frequent serious adverse events reported in patients treated with OFEV, were worsening of interstitial lung disease (4.5% in both treatment groups) and pneumonia (2.8% OFEV vs. 0.3% placebo). Within 52 weeks, 5 patients treated with OFEV (1.7%) and 4 patients treated with placebo (1.4%) died. There was no pattern among adverse events leading to death in either treatment arm.

The most common adverse reactions with an incidence of >3% in OFEV-treated patients and more commonly than in placebo are listed in Table 2.

Table 2 Adverse events occurring in >3% of patients treated with OFEV and more frequently than with placebo by > 1.5%, by SOC and preferred term, sorted by frequency in the OFEV 150 mg group in trial 1199.214

System organ class/ Preferred term	Placebo N (%)	OFEV 150 mg bid N (%)
Patients	288 (100)	288 (100)
Patient with any AE	276 (96)	283 (98)
Gastrointestinal disorders		
Diarrhea	91 (31.6)	218 (75.7)
Nausea	39 (13.5)	91 (31.6)
Vomiting	30 (10.4)	71 (24.7)
Abdominal pain ^a	32 (11.1)	53 (18.4)
Infections and Infestations		
Pneumonia	6 (2.1)	12 (4.2)
Investigations		
Weight decreased	12 (4.2)	34 (11.8)
Liver enzyme elevation ^b	9 (3.1)	38 (13.2)
Metabolism and nutrition disorders		

Decreased appetite	12 (4.2)	24 (9.4)
Musculoskeletal and connective tissue disorders		
Musculoskeletal pain	4 (1.4)	11 (3.8)
Vascular disorders		
Hypertension ^c	5 (1.7)	14 (4.9)
General disorders		
Fatigue	20 (6.9)	31 (10.8)
Nervous system disorders		
Dizziness	12 (4.2)	17 (5.9)

a Includes abdominal pain, abdominal pain upper, abdominal pain lower, and esophageal pain.

b Includes alanine aminotransferase increased, gamma-glutamyltransferase increased, aspartate aminotransferase increased, hepatic enzyme increased, blood alkaline phosphatase increased, transaminase increased, and hepatic function abnormal.

c Includes hypertension, blood pressure increased, and hypertensive crisis.

Less Common Clinical Trial Adverse Drug Reactions (<3%) in trial 1199.214

There were no cases of hyperbilirubinaemia in trial 1199.214.

Skin and subcutaneous tissue disorders: alopecia (studies in patients with SSc-ILD: 1%)

Other Chronic Fibrosing Interstitial Lung Diseases (ILDs) with a Progressive Phenotype

The following safety data are based on a phase 3, randomized, double-blind, placebo-controlled study in 663 patients with other chronic fibrosing ILDs with a progressive phenotype comparing treatment with nintedanib 150 mg twice daily to placebo for at least 52 weeks.

Common adverse events in 1199.247, i.e. those that occurred in >3% of patients treated with nintedanib and more frequently than with placebo by $\geq 1.5\%$ are shown in Table 2.

Table 2: Adverse events occurring in >3% of patients treated with nintedanib and more frequently than with placebo by > 1.5%, by SOC and preferred term, sorted by frequency in the nintedanib 150 mg group in trial 1199.247

System organ class/ Preferred term	Placebo N (%)	Nintedanib 150 mg bid N (%)
Patients	331 (100.0)	332 (100.0)
Patients with any AE		
Gastrointestinal disorders		
Diarrhea	79 (23.9)	222 (66.9)
Nausea	31 (9.4)	96 (28.9)
Vomiting	17 (5.1)	16 (18.4)
Abdominal pain ^a	16 (4.8)	60 (18.1)
Gastroesophageal reflux disease	6 (1.8)	13 (3.9)

System organ class/ Preferred term	Placebo N (%)	Nintedanib 150 mg bid N (%)
Hepatobiliary disorders		
Liver enzyme elevations ^b	19 (5.7)	75 (22.6)
Metabolism and nutrition disorders		
Decreased appetite	17 (5.1)	48 (14.5)
Investigations		
Weight decreased	11 (3.3)	41 (12.3)
Nervous system disorders		
Headache	23 (6.9)	35 (10.5)
Infections and Infestations		
Urinary tract infection	13 (3.9)	20 (6.0)

^a Includes abdominal pain, abdominal pain upper, abdominal pain lower.

^b Includes alanine aminotransferase increased, aspartate aminotransferase increased, gamma-glutamyltransferase increased, hepatic enzyme increased, blood alkaline phosphatase increased, transaminase increased, hypertransaminasemia and hepatic function abnormal.

In addition, hypertension was reported in 5% of patients in both treatment groups.

Adverse Events leading to Discontinuation of Study Medication in trial 1199.247

Adverse events leading to discontinuation were reported in 20% of OFEV-treated patients and 10% of placebo-treated patients. The most frequent adverse reaction that led to discontinuation in OFEV-treated patients was diarrhea (6%).

Adverse Events Leading to Dose Reduction in trial 1199.247

Adverse events leading to dose reductions were reported in 33% of OFEV-treated patients and 4% of placebo-treated patients. The most frequent adverse reaction that led to dose reduction in the patients treated with OFEV was diarrhea (16%).

Serious Adverse Events

Within 52 weeks, the frequency of patients with serious adverse events was similar between the OFEV and placebo treatment groups. The most frequent serious adverse event reported in patients treated with OFEV, more than placebo, was pneumonia (4% vs. 3%). Adverse events leading to death were reported less frequently in patients treated with OFEV compared with placebo (3% versus 5%, respectively). The difference between treatment groups was driven by death related to the respiratory system. No further pattern was identified in the adverse events leading to death.

Less Common Clinical Trial Adverse Drug Reactions (<3%) in trial 1199.247

Adverse drug reactions occurring in <3% of patients treated with OFEV and more than placebo in trial 1199.247 are listed below:

Hepatobiliary Disorders: hyperbilirubinemia

Skin and subcutaneous disorders: alopecia (study in patients with other chronic fibrosing ILDs with a progressive phenotype: 2%)

Post-Market Adverse Drug Reactions

The following additional adverse reactions have been identified during post-approval use of OFEV. Because these reactions are reported voluntarily from a population of uncertain size, it is not always possible to reliably estimate their frequency or establish a causal relationship to drug exposure.

Gastrointestinal disorders: Pancreatitis

Vascular disorders: Non-serious and serious bleeding events (involving different organ systems including gastrointestinal, respiratory and central nervous organ systems), some of which were fatal. Aneurysms and artery dissections.

Blood and lymphatic system disorders: Thrombocytopenia

Hepatobiliary Disorders: Drug-induced liver injury

Skin and subcutaneous tissue disorders: Rash, pruritus

DRUG INTERACTIONS

Overview

Drug-Drug Interactions

P-glycoprotein (P-gp) and Cytochrome (CYP)-3A4

Nintedanib is a substrate of P-gp and to a minor extent CYP3A4 (see [ACTION AND CLINICAL PHARMACOLOGY, Pharmacokinetics](#) section). Nintedanib and its metabolites, the free acid moiety BIBF 1202 and its glucuronide BIBF 1202 glucuronide, did not inhibit or induce CYP enzymes in preclinical studies.

Co-administration with the potent P-gp and CYP3A4 inhibitor ketoconazole increased exposure to nintedanib by 1.61 fold for AUC and by 1.83 fold for C_{max} in a drug-drug interaction study. Concomitant use of P-gp and CYP3A4 inhibitors with OFEV may increase exposure to nintedanib.

Co-administration with the potent P-gp and CYP3A4 inducer rifampicin decreased exposure to nintedanib to 50 % based on AUC and to 60 % based on C_{max}.

Table 3 Established or Potential Drug-Drug Interactions

Nintedanib	Ref	Effect	Clinical comment
<u>Inhibitors of P-gp and CYP3A4</u> ketoconazole or erythromycin	CT	Co-administration with the potent P-gp and CYP 3A4 inhibitor ketoconazole increased exposure to nintedanib. If co-administered with OFEV, potent P-gp and CYP 3A4 inhibitors (e.g. ketoconazole or erythromycin) may increase exposure to nintedanib.	In such cases, patients should be monitored closely for tolerability of nintedanib. Management of side effects may require interruption, dose reduction, or discontinuation of therapy with OFEV (see DOSAGE AND ADMINISTRATION section).
<u>Inducers of P-gp and CYP3A4</u> rifampicin, carbamazepine, phenytoin, and St. John's Wort	CT	Co-administration with the potent P-gp and CYP 3A4 inducer rifampicin decreased exposure to nintedanib. Potent P-gp and CYP 3A4 inducers (e.g. rifampicin, carbamazepine, phenytoin, and St. John's Wort) may decrease exposure to nintedanib.	Co-administration with OFEV should be carefully considered. Selection of an alternate concomitant medication with no or minimal P-gp induction potential should be considered.

Legend: CT = Clinical Trial

Bosentan

Co-administration of nintedanib with bosentan did not alter the pharmacokinetics of nintedanib.

Hormonal contraceptives

The potential for interactions of nintedanib with hormonal contraceptives was not evaluated.

Pirfenidone

Concomitant treatment with nintedanib and pirfenidone has been investigated in patients with IPF in an exploratory open-label, randomized trial of nintedanib 150 mg twice daily with add-on pirfenidone (titrated to 801 mg three times a day) compared to nintedanib 150 mg twice daily alone in 105 randomized patients for 12 weeks. The primary endpoint was the percentage of patients with gastrointestinal adverse events from baseline to week 12. The incidence of investigator-defined drug-related adverse events was higher for patients on nintedanib with add-on pirfenidone (79.2%) than on nintedanib alone (58.8%). Gastrointestinal adverse events were frequent and in line with the established safety profile of each component. Diarrhea, nausea and vomiting were the most frequent adverse events reported in 20 (37.7%) versus 16 (31.4%), in 22 (41.5%) versus 6 (11.8%) and in 15 (28.3%) versus 6 (11.8%) patients, treated with pirfenidone added to nintedanib versus nintedanib alone, respectively.

Drug-Food Interactions

OFEV is recommended to be taken with food (see [DOSAGE AND ADMINISTRATION](#) and [ACTION AND CLINICAL PHARMACOLOGY, Pharmacokinetics](#) sections).

Grapefruit juice contains one or more components that moderately inhibit CYP3A and P-gp and its co-administration may increase plasma concentrations of nintedanib. Food containing

grapefruit or Seville oranges should be avoided during treatment with OFEV.

Drug-Lifestyle Interactions

Effects on ability to drive and use machines

No studies of the effects on the ability to drive and use machines have been performed. Patients should be advised to be cautious when driving or using machines during treatment with OFEV.

DOSAGE AND ADMINISTRATION

Dosing Considerations

Treatment should be initiated by physicians experienced in the diagnosis and treatment of conditions for which OFEV is indicated.

Hepatic transaminase and bilirubin levels should be investigated just before initiation of treatment with OFEV, then at regular intervals (monthly) during the first three months of treatment and periodically thereafter (e.g. at each patient visit) or as clinically indicated. Conduct liver tests promptly in patients who reports symptoms that may indicate liver injury, including fatigue, anorexia, right upper abdominal discomfort, dark urine or jaundice.

Pregnancy testing should be conducted prior to initiating treatment with OFEV and during treatment as appropriate, in females of reproductive potential.

Recommended Dose and Dosage Adjustment

The recommended dose of OFEV is 150 mg twice daily administered approximately 12 hours apart.

Dose adjustments due to adverse reactions

In addition to symptomatic treatment if applicable, the management of adverse reactions of OFEV could include dose reduction (to 100 mg twice daily) and temporary interruption of OFEV treatment until the specific adverse reaction has resolved to levels that allow continuation of therapy. OFEV treatment may be resumed at the full recommended dose (150 mg twice daily) or a reduced dose (100 mg twice daily). If a patient does not tolerate 100 mg twice daily, treatment with OFEV should be discontinued (see [WARNINGS AND PRECAUTIONS](#) section and [ADVERSE REACTIONS](#) section).

Cases of drug-induced liver injury (DILI), have been reported in patients treated with OFEV (nintedanib). In the majority of cases, the DILI was reversible when the dose was reduced or treatment was stopped.

- Treatment interruption or dose reduction to 100 mg twice daily is recommended for patients whose transaminase (AST or ALT) are measured greater than 3 times to less than 5 times the upper limit of normal (ULN) without signs of liver damage. These patients should be monitored closely. Alternative causes of the liver enzyme elevations should be

investigated. Once transaminases have returned to baseline values, treatment with OFEV may be reintroduced at a reduced dose (100 mg twice daily) which subsequently may be increased to the full recommended dose (150 mg twice daily) (see [WARNINGS AND PRECAUTIONS](#) section and [ADVERSE REACTIONS](#) section).

- Treatment with OFEV should be permanently discontinued 1) if transaminase (ASR or ALT) elevations are greater than 5 times ULN, or 2) if transaminase (AST or ALT) elevations are greater than 3 times ULN with clinical signs or symptoms of liver injury which may include fatigue, anorexia, right upper abdominal discomfort, dark urine or jaundice (see [WARNINGS AND PRECAUTIONS](#) section and [ADVERSE REACTIONS](#) section).

Hepatic impairment

Mild hepatic impairment: In patients with mild hepatic impairment (Child Pugh A), the recommended dose of OFEV is 100 mg twice daily approximately 12 hours apart. Treatment interruption or discontinuation for management of adverse reactions should be considered.

Moderate and severe hepatic impairment: Treatment of patients with moderate (Child Pugh B) or severe (Child Pugh C) hepatic impairment with OFEV is not recommended. The safety and efficacy of nintedanib have not been investigated in patients with hepatic impairment classified as Child Pugh B and C. Exposure to nintedanib increased significantly in patients with moderate hepatic impairment (see section [ACTION AND CLINICAL PHARMACOLOGY, Pharmacokinetics](#)).

Race

Safety data for African American patients is limited.

Renal impairment

Adjustment of the recommended dose (150 mg twice daily) in patients with mild to moderate renal impairment is not required. The safety, efficacy, and pharmacokinetics of nintedanib have not been studied in patients with severe renal impairment (<30 ml/min CrCL).

Geriatrics (>65 years of age):

No dose adjustment is required on the basis of a patient's age.

Administration

OFEV capsules should be taken with food, swallowed whole with water, and should not be chewed or crushed.

Missed Dose

If a dose of OFEV is missed, administration should resume at the next scheduled time at the recommended dose. If a dose is missed the patient should not be given an additional dose. The recommended maximum daily dose of 300 mg should not be exceeded.

OVERDOSAGE

For management of a suspected drug overdose, contact your regional Poison Control Centre.

There is no specific antidote or treatment for OFEV overdose. The highest single dose of nintedanib administered in phase 1 studies was 450 mg once daily. In addition, 2 patients had an overdose of maximum 600 mg bid up to eight days. Observed adverse events were consistent with the known safety profile of nintedanib, i.e. increased liver enzymes and gastrointestinal symptoms. Both patients recovered from these adverse reactions.

In the clinical trials in patients with IPF, one patient was inadvertently exposed to a dose of 600 mg daily for a total of 21 days. A non-serious adverse event (nasopharyngitis) occurred and resolved during the period of incorrect dosing, with no onset of other reported events.

In case of overdose, treatment should be interrupted and general supportive measures initiated as appropriate.

ACTION AND CLINICAL PHARMACOLOGY

Mechanism of Action

Nintedanib is a small molecule that inhibits multiple receptor tyrosine kinases including: platelet-derived growth factor receptor (PDGFR) α and β , fibroblast growth factor receptor (FGFR) 1-3, vascular endothelial growth factor receptor (VEGFR) 1-3 and colony stimulating factor 1 receptor (CSF1R). In addition, nintedanib inhibits non-receptor tyrosine kinases including: Lck, Lyn, and Src kinases. Nintedanib binds competitively to the ATP binding pocket of these kinases and blocks the intracellular signalling cascades, which have been demonstrated to be involved in the pathogenesis of fibrotic tissue remodelling in interstitial lung diseases. In *in vivo* studies, nintedanib was shown to have potent anti-fibrotic and anti-inflammatory activity.

Pharmacodynamics

QT interval

In a dedicated study in renal cell cancer patients, QT/QTc measurements were recorded and showed that a single oral dose of 200 mg nintedanib as well as multiple oral doses of 200 mg nintedanib administered twice daily for 15 days did not prolong the QTcF interval.

Pharmacokinetics

The pharmacokinetics (PK) of nintedanib can be considered linear with respect to time (i.e. single-dose data can be extrapolated to multiple-dose data) and dose. Accumulation upon multiple administrations was 1.04-fold for C_{max} and 1.38-fold for AUC_{τ} . Nintedanib trough concentrations remained stable for more than one year.

Table 4 Pharmacokinetic parameters of nintedanib after single oral administration of 150 mg nintedanib to healthy volunteers

Nintedanib	N	gMean	%gCV
C _{max} [ng/mL]	26	22.1	51.8
t _{max} ¹ [h]	26	3.00	0.500–6.00
AUC _{0-∞} [ng·h/mL]	26	183	36.1

¹ median and range

Absorption:

Nintedanib reached maximum plasma concentrations approximately 2 - 4 hours after oral administration as soft gelatin capsule under fed conditions (range 0.5 - 8 hours). The absolute bioavailability of a 100 mg dose was 4.7% in healthy volunteers. Absorption and bioavailability are decreased by transporter effects and substantial first-pass metabolism.

Steady state plasma concentrations were achieved within one week of dosing at the latest.

Although the impact of food on the extent of nintedanib absorption is variable, when administered after food intake, nintedanib exposure generally increased by 20-50% compared to administration under fasted conditions and absorption was delayed (median T_{max} fasted: 2.00 hours; fed: 3.98 hours).

Distribution:

Nintedanib follows at least bi-phasic disposition kinetics. After intravenous infusion, a high volume of distribution (V_{ss}: 1050 L, 45.0% gCV) was observed.

The *in vitro* protein binding of nintedanib in human plasma was high, with a bound fraction of 97.8%. Serum albumin is considered to be the major binding protein. Nintedanib is preferentially distributed in plasma with a blood to plasma ratio of 0.87.

Metabolism:

The prevalent metabolic reaction for nintedanib is hydrolytic cleavage by esterases resulting in the free acid moiety BIBF 1202. BIBF 1202 is subsequently glucuronidated by UGT enzymes, namely UGT 1A1, UGT 1A7, UGT 1A8, and UGT 1A10 to BIBF 1202 glucuronide.

Only a minor extent of the biotransformation of nintedanib consisted of CYP pathways, with CYP 3A4 being the predominant enzyme involved. The major CYP-dependent metabolite could not be detected in plasma in the human ADME study. *In vitro*, CYP-dependent metabolism accounted for about 5% compared to about 25% ester cleavage.

In preclinical *in vivo* experiments, BIBF 1202 did not show efficacy despite its activity at target receptors of the drug.

Elimination:

Total plasma clearance after intravenous infusion was high (CL: 1390 mL/min). Urinary excretion of unchanged drug within 48 h was about 0.05% of the dose after oral and about 1.4% of the dose after intravenous administration; the renal clearance was 20 mL/min. The major route

of elimination of drug related radioactivity after oral administration of [¹⁴C] nintedanib was via faecal/biliary excretion (93.4% of dose). The contribution of renal excretion to the total clearance was low (0.65% of dose). The overall recovery was considered complete (above 90%) within 4 days after dosing. The terminal half-life of nintedanib was between 10 and 15 hours.

Transport:

Nintedanib is a substrate of P-gp. For the interaction potential of nintedanib with this transporter, see [DRUG INTERACTIONS](#) section. Nintedanib was shown not to be a substrate or inhibitor of OATP-1B1, OATP-1B3, OATP-2B1, OCT-2 or MRP-2 *in vitro*. Nintedanib was also not a substrate of BCRP. Only a weak inhibitory potential on OCT-1, BCRP, and P-gp was observed *in vitro* which is considered to be of low clinical relevance. The same applies for nintedanib being a substrate of OCT-1.

Exposure-response relationship

In exploratory pharmacokinetic (PK)-adverse event analyses based on the phase 2 IPF data, higher exposure to nintedanib tended to be associated with liver enzyme elevations (see [WARNINGS AND PRECAUTIONS](#) section).

Intrinsic and Extrinsic Factors; Special Populations

The PK properties of nintedanib were similar in healthy volunteers, patients with IPF, patients with SSc-ILD and patients with other chronic fibrosing ILDs with a progressive phenotype. Based on results of a Population PK analysis and descriptive investigations, moderate effects on exposure to nintedanib by age, body weight, smoking status and race were observed. Based on the high inter-individual variability of exposure, the observed moderate effects are not sufficient to warrant a dose adjustment (see [WARNINGS AND PRECAUTIONS](#) section).

Special Populations and Conditions

Pediatrics:

Studies in pediatric populations have not been performed.

Geriatrics:

Exposure to nintedanib increased linearly with age. $AUC_{\tau,ss}$ decreased by 16% for a 45-year old patient (5th percentile) and increased by 13% for a 76-year old patient (95th percentile) relative to a patient with the median age of 62 years. The age range covered by the analysis was 29 to 85 years; approximately 5% of the population was older than 75 years.

Race:

The population mean exposure to nintedanib was 33-50% higher in Chinese, Taiwanese, and Indian patients and 16% higher in Japanese patients while it was 16-22% lower in Koreans compared to Caucasians (body weight corrected).

Hepatic Insufficiency:

A dedicated single-dose phase 1 study compared the pharmacokinetics of OFEV in 8 subjects with mild hepatic impairment (Child Pugh A) and 8 subjects with moderate hepatic impairment (Child Pugh B) to healthy matched control subjects (N=8 per hepatic impairment group). In subjects with mild hepatic impairment, the mean exposure to nintedanib was 2.2-fold higher based on C_{\max} (90% CI 1.3 – 3.7) and $AUC_{0-\infty}$ (90% CI 1.2 – 3.8) compared to healthy subjects. In subjects with moderate hepatic impairment, exposure was 7.6-fold higher based on C_{\max} (90% CI 4.4 – 13.2) and 8.7-fold higher (90% CI 5.7 – 13.1) based on $AUC_{0-\infty}$ compared to healthy volunteers. Subjects with severe hepatic impairment (Child Pugh C) have not been studied.

Renal Insufficiency:

Based on a population PK analysis of data from patients with IPF, exposure to nintedanib was not influenced by mild (CrCl: 60 to 90 mL/min) or moderate (CrCl: 30 to 60 mL/min) renal impairment. Data in severe renal impairment (CrCl below 30 mL/min) were limited.

Body Weight:

An inverse correlation between body weight and exposure to nintedanib was observed. $AUC_{\tau,ss}$ increased by 25% for a 50 kg patient (5th percentile) and decreased by 19% for a 100 kg patient (95th percentile) relative to a patient with the median weight of 71.5 kg.

Smokers:

Smoking was associated with a 21% lower exposure to nintedanib compared to ex- and never-smokers. No dose adjustment is warranted.

Concomitant Treatment with Bosentan:

Co-administration of nintedanib with bosentan did not alter the pharmacokinetics of nintedanib. In a dedicated pharmacokinetic study, concomitant treatment of nintedanib with bosentan was investigated in healthy volunteers. Subjects received a single dose of 150 mg nintedanib before and after multiple dosing of 125 mg bosentan twice daily at steady state. The adjusted geometric mean ratios and its 90% confidence interval (CI) were 103% (86% - 124%) and 99% (91%-107%) for C_{\max} and AUC_{0-tz} of nintedanib, respectively (n=13).

Concomitant Treatment with Pirfenidone:

In a dedicated pharmacokinetic study, concomitant treatment of nintedanib with pirfenidone was investigated in patients with IPF. Group 1 received a single dose of 150 mg nintedanib before and after up-titration to 801 mg pirfenidone three times a day at steady state. Group 2 received steady state treatment of 801 mg pirfenidone three times a day and had a PK profiling before and after at least 7 days of co-treatment with 150 mg nintedanib twice daily. In group 1, the adjusted geometric mean ratios (90% CI) were 93% (57% - 151%) and 96% (70% - 131%) for C_{\max} and AUC_{0-tz} of nintedanib, respectively (n=12). In group 2, the adjusted geometric mean ratios (90% CI) were 97% (86% - 110%) and 95% (86% - 106%) for $C_{\max,ss}$ and $AUC_{\tau,ss}$ of pirfenidone, respectively (n=12).

STORAGE AND STABILITY

Store at 15 – 25°C.

SPECIAL HANDLING INSTRUCTIONS

Store in the original package in order to protect from moisture.

DOSAGE FORMS, COMPOSITION AND PACKAGING

OFEV soft capsules are available in two different strengths of 100 and 150 mg of nintedanib (as a free base) corresponding to 120.40 mg and 180.60 mg of nintedanib ethanesulfonate (esilate), respectively:

- 100 mg soft capsules are peach-colored, opaque, oblong soft-gelatin capsules imprinted on one side in black with the Boehringer Ingelheim company symbol and “100”.
- 150 mg soft capsules are brown-colored, opaque, oblong soft-gelatin capsule imprinted on one side in black with the Boehringer Ingelheim company symbol and “150”

Excipients

Capsule fill: Medium chain triglycerides, hard fat, soya lecithin (E322)

Capsule shell: Gelatin, glycerol 85 %, titanium dioxide (E171), iron oxide red (E172), iron oxide yellow (E172), black ink (Opacode®)

Black ink: Shellac glaze, iron oxide black (E172), propylene glycol (E1520)

OFEV soft capsules are packaged in unit dose blister cards with push-through foil and individually molded cavities (10-count blister card with cross perforation). The blister cards are composed of a laminated aluminum bottom foil and a printed aluminum lidding foil.

OFEV 100 mg soft capsules are available in the following packaging sizes: Six blister cards are packed into a folding box resulting in pack sizes of 6 x 10 capsules per pack.

OFEV 150 mg soft capsules are available in the following packaging sizes: Six blister cards are packed into a folding box resulting in pack sizes of 6 x 10 capsules per pack and three blister cards are packed into a folding box resulting in pack sizes of 3 x 10 capsules per pack.

PART II: SCIENTIFIC INFORMATION

PHARMACEUTICAL INFORMATION

Drug Substance

Common name: nintedanib esilate

Chemical name:

CAS Index name:

1H-indole-6-carboxylic acid, 2,3-dihydro-3-[[[4-[methyl[(4-methyl-1-piperazinyl)acetyl]-amino]phenyl]amino]phenylmethylene]-2-oxo-, methyl ester, (3Z)-, ethanesulfonate (1:1)

Molecular formula and molecular mass:

$C_{31}H_{33}N_5O_4 \cdot C_2H_6O_3S$ ($C_{33}H_{39}N_5O_7S$)
649.76 g/mol (ethanesulfonate salt), 539.62 g/mol (free base)

Structural formula:

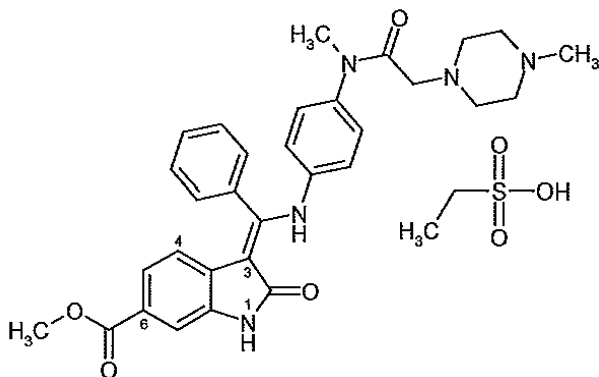

Physicochemical properties:

Physical description: bright yellow powder.

Melting Point: $T_{fus} = 305 \pm 5 \text{ }^\circ\text{C}$
 $\Delta H_{fus} = 82 \pm 5 \text{ J/g}$

Dissociation Constants: $pK_{a1} = 7.9 \pm 0.2$ (piperazine moiety)
 $pK_{a2} = 2.1 \pm 0.2$ (piperazine moiety)

Partition Coefficient: $\text{Log D (pH 7.4)} = 3.0$

pH Solubility Profile: nintedanib shows good solubility behaviour (> 1 mg/ml) in acidic media. Above pH 3 solubility of nintedanib drops by at least three orders of magnitude to the lower solubility of the monocationic form and its free base (< 0.001 mg/ml at pH≥7). The intrinsic dissolution rate is fast in acidic media (> 1000 µg/cm²/min up to pH 2.0). In water a solubility of 2.8 mg/ml was found; the resulting solution shows an intrinsic pH of 5.7.

CLINICAL TRIALS

Idiopathic Pulmonary Fibrosis (IPF)

The clinical efficacy of nintedanib has been studied in patients with IPF in two phase 3, randomized, double-blind, placebo-controlled studies with identical design (1199.32 and 1199.34). Patients were randomized in a 3:2 ratio to treatment with nintedanib 150 mg or placebo twice daily for 52 weeks. Dose reduction to 100 mg twice daily and dose interruptions were allowed to manage adverse events.

The two phase 3 trials included male and female patients 40 years of age and older, with a diagnosis of IPF (ATS/ERS/JRS/ALAT criteria) for < 5 years. Diagnoses were centrally adjudicated based on radiological and, if available, histopathological confirmation. Patients were required to have an FVC ≥ 50% predicted of normal and a carbon monoxide diffusing capacity (DLCO, corrected for hemoglobin) 30% to 79% predicted of normal. Patients with a known risk or predisposition to bleeding, patients receiving a full dose of anticoagulation treatment, and patients with a recent history of myocardial infarction or stroke were excluded from the studies.

The primary endpoint was the annual rate of decline in Forced Vital Capacity (FVC). The key secondary endpoints were change from baseline in St. George’s Respiratory Questionnaire (SGRQ) total score at 52 weeks and time to first acute IPF exacerbation.

Study demographics and trial design

Table 5 Summary of patient demographics in trials 1199.32 and 1199.34

Study #	Trial design	Dosage, route of administration and duration	Study subjects (n=number)	Mean age (Standard Deviation (StD))	Gender
1199.32	Multicentre, randomized, double-blind	Eligible patients were randomized in 3:2 ratio to receive nintedanib 150 mg bid or placebo for 52 weeks.	Nintedanib: n=309 Placebo: n=204	66.9 (StD 8.4) years	81% male and 19% female

Study #	Trial design	Dosage, route of administration and duration	Study subjects (n=number)	Mean age (Standard Deviation (StD))	Gender
1199.34	Multicentre, randomized, double-blind	Eligible patients were randomized in 3:2 ratio to receive nintedanib 150 mg bid or placebo for 52 weeks.	Nintedanib: n=329 Placebo: n=219	66.4 (StD 7.9) years	78% male and 22% female

Study results

Annual rate of decline in FVC

The annual rate of decline in FVC (in mL) was significantly reduced in patients receiving nintedanib compared to patients receiving placebo. The treatment effect was consistent in both trials. See Table 6 for individual and pooled study results.

Table 6 Annual rate of decline in FVC (mL) in trials 1199.32, 1199.34 and their pooled data - treated set

	1199.32		1199.34		1199.32 and 1199.34 pooled	
	Placebo	Nintedanib 150 mg twice daily	Placebo	Nintedanib 150 mg twice daily	Placebo	Nintedanib 150 mg twice daily
Number of analysed patients	204	309	219	329	423	638
Rate ¹ (SE) of decline over 52 weeks	-239.9 (18.71)	-114.7 (15.33)	-207.3 (19.31)	-113.6 (15.73)	-223.5 (13.45)	-113.6 (10.98)
Comparison vs. placebo Difference ¹		125.3		93.7		109.9
95% CI		(77.7, 172.8)		(44.8, 142.7)		(75.9, 144.0)
p-value		<0.0001		0.0002		<0.0001
¹ Estimated based on a random coefficient regression model.						

The robustness of the effect of nintedanib in reducing the annual rate of decline in FVC was confirmed in all pre-specified sensitivity analyses. See Figure 1 for the evolution of change from baseline over time in both treatment groups, based on the pooled analyses of studies 1199.32 and 1199.34.

Figure 1 Mean (SEM) observed FVC change from baseline (mL) over time, studies 1199.32 and 1199.34 pooled

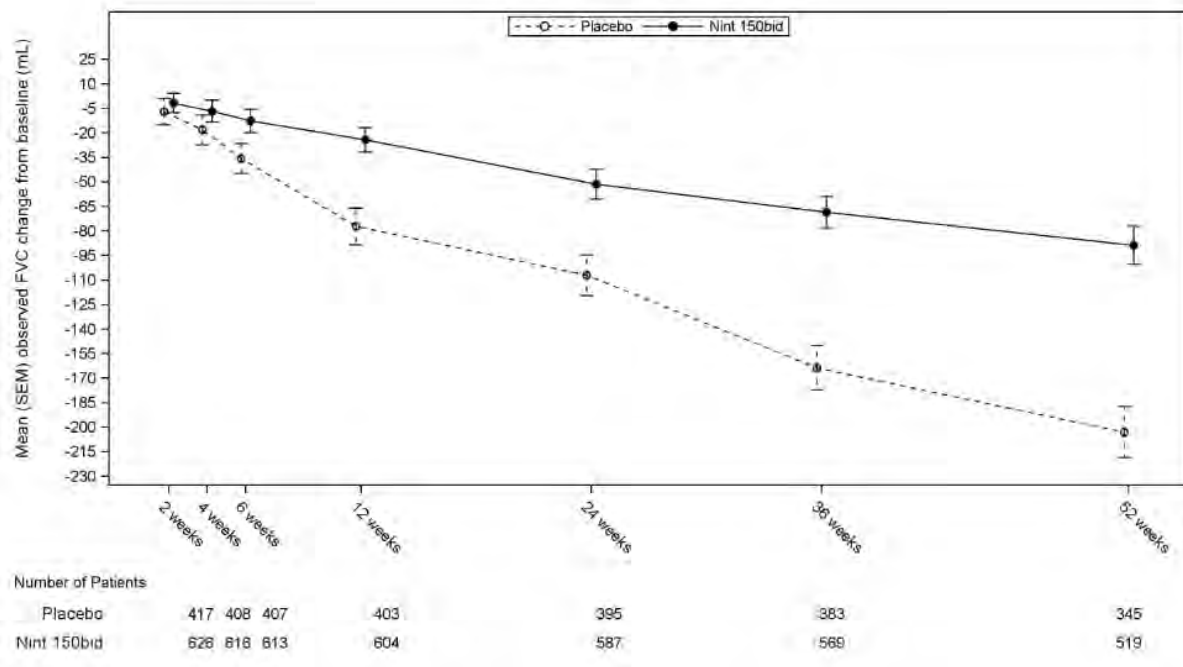

bid = twice daily

Time to first acute IPF exacerbation

The time to first acute IPF exacerbation was a key secondary endpoint in trials 1199.32 and 1199.34. In trial 1199.34, the risk of first acute IPF exacerbation over 52 weeks was significantly reduced in patients receiving nintedanib compared to placebo (Hazard ratio (HR): 0.38; 95% CI 0.19, 0.77), whereas in trial 1199.32 there was no difference between the treatment groups (Hazard ratio: 1.15; 95% CI 0.54, 2.42). In the pooled analysis of the clinical trials, a numerically lower risk of first acute exacerbation was observed in patients receiving nintedanib compared to placebo (Hazard ratio: 0.64; 95% CI 0.39, 1.05).

All adverse events of acute IPF exacerbation reported by the investigator were adjudicated by a blinded adjudication committee. An analysis of the time to first ‘confirmed’ or ‘suspected’ adjudicated acute IPF exacerbation was performed. The frequency of patients with at least 1 adjudicated exacerbation occurring within 52 weeks was lower in the nintedanib group than in the placebo group for both clinical trials. Time to event analysis of the adjudicated exacerbation events yielded an HR 0.55 (95% CI: 0.20, 1.54) for trial 1199.32 and an HR of 0.20 (95% CI: 0.07, 0.56) for trial 1199.34.

Change from baseline in St. George’s Respiratory Questionnaire total score at week 52

St. George’s Respiratory Questionnaire (SGRQ) total score measuring health related quality of life was analysed at 52 weeks as a key secondary endpoint in the two clinical trials. In trial

1199.32, the increase from baseline in SGRQ total score at week 52 was comparable between nintedanib and placebo (difference between treatment groups: -0.05; 95% CI: -2.50, 2.40; $p=0.9657$).

In trial 1199.34, patients receiving placebo had a larger increase (i.e. worsening) from baseline in SGRQ total score as compared to patients receiving nintedanib 150 mg bid, and the difference between the treatment groups was statistically significant (-2.69; 95% CI: -4.95, -0.43; $p=0.0197$).

Survival analysis

Survival was evaluated in trials 1199.32 and 1199.34 as an exploratory analysis to support the primary endpoint (FVC). In the pre-specified pooled analysis of survival data of the clinical trials, all-cause mortality over 52 weeks was numerically lower in the nintedanib group (5.5%) compared with the placebo group (7.8%). The analysis of time to death resulted in a HR of 0.70 (95% CI 0.43, 1.12; $p=0.1399$). The results of all survival endpoints (such as on-treatment mortality and respiratory mortality) showed a consistent numerical difference in favour of nintedanib.

Supportive evidence from the phase 2 trial (1199.30) Nintedanib 150 mg twice daily results:

Additional evidence of efficacy is provided by the randomized, double-blind, placebo-controlled, dose finding phase 2 trial including a nintedanib 150 mg bid dose group. This was a 52 week study in patients with IPF and included a total of 432 randomized patients with 85 patients treated with nintedanib 150 mg and 85 patients treated with placebo.

The primary endpoint, rate of decline in FVC over 52 weeks, was lower in the 150 mg nintedanib arm (-0.060 L/year, N=84) than the placebo arm (-0.190 L/year, N=83). The estimated difference between the treatment groups was 0.131 L/year (95% CI 0.027, 0.235) reaching nominal statistical significance ($p=0.0136$).

Systemic Sclerosis associated Interstitial Lung Disease (SSc-ILD)

The clinical efficacy of nintedanib has been studied in patients with SSc-ILD in a randomized, double-blind, placebo-controlled phase 3 trial (1199.214). A total of 580 patients were randomized in a 1:1 ratio to treatment with OFEV (nintedanib) 150 mg bid or placebo twice daily for at least 52 weeks, of which 576 were treated. Randomization was stratified by Antitopoisomerase Antibody status (ATA). Individual patients remained on blinded trial treatment for up to 100 weeks (median nintedanib exposure 15.4 months; mean nintedanib exposure 14.5 months). Dose reduction to 100 mg twice daily and dose interruptions were allowed to manage adverse events. The primary endpoint was the annual rate of decline in Forced Vital Capacity (FVC) over 52 weeks. Key secondary endpoints were change from baseline in modified Rodnan Skin Score (mRSS) at 52 weeks and change from baseline in the St. George's Respiratory Questionnaire (SGRQ) total score at 52 weeks. Mortality over the whole trial was an additional secondary endpoint.

Patients were diagnosed with SSc-ILD based upon the 2013 American College of Rheumatology/European League Against Rheumatism classification criteria for SSc with onset of disease (first non-Raynaud symptom) of less than 7 years and greater than or equal to 10% fibrosis on a chest high resolution computed tomography (HRCT) scan conducted within the previous 12 months. Patients were required to have an FVC \geq 40% of predicted and a DLCO 30-89% of predicted. Patients with relevant airways obstruction (i.e., pre-bronchodilator FEV₁/FVC less than 0.7) or previous or planned hematopoietic stem cell transplant were excluded from the trial. Patients with greater than 1.5 times ULN of ALT, AST, or bilirubin, patients with a known risk or predisposition to bleeding, patients receiving a full dose of anticoagulation treatment, and patients with a recent history of myocardial infarction or stroke were excluded from the study. Patients were excluded if they had significant pulmonary hypertension, more than three digital fingertip ulcers, a history of severe digital necrosis requiring hospitalization, or a history of scleroderma renal crisis. Patients were also excluded if they received other investigational therapy, previous treatment with nintedanib or pirfenidone, azathioprine within 8 weeks prior to randomization, or cyclophosphamide or cyclosporine A within 6 months prior to randomization.

In the overall population, 75% of the patients were female. The mean (standard deviation [SD, Min-Max]) age was 54 (12.2, 20-79) years. Overall, 52% of patients had diffuse cutaneous Systemic Sclerosis (SSc) and 48% had limited cutaneous SSc. The mean (SD) time since first onset of non-Raynaud symptom was 3.49 (1.7) years. 49% of patients were on stable therapy with mycophenolate at baseline.

Study demographics and trial design

Table 7 Summary of patient demographics in trial 1199.214

Study #	Trial design	Dosage, route of administration and duration	Study subjects (n=number)	Mean age (Standard Deviation (StD))	Gender
1199.214	Multicentre, randomized, double-blind	Eligible patients were randomized in 1:1 ratio to receive nintedanib 150 mg bid or placebo for at least 52 weeks.	Nintedanib: n=288 Placebo: n=288	54 (StD 12.2 years)	25% male and 75% female

Study results

Annual rate of decline in FVC

The annual rate of decline of FVC (in mL) over 52 weeks was significantly reduced by 41 mL in patients receiving nintedanib compared to patients receiving placebo (Table 8) corresponding to a relative treatment effect of 43.8%.

Table 8 Annual rate of decline in FVC (mL) in trial 1199.214

	Placebo	Nintedanib 150 mg twice daily
Number of analysed patients	288	287
Rate ¹ (SE) of decline over 52 weeks	-93.3 (13.5)	-52.4 (13.8)
Comparison vs placebo		
Difference ¹		41.0
95% CI		(2.9, 79.0)
p-value		<0.05
¹ Based on a random coefficient regression with fixed categorical effects of treatment, ATA status, gender, fixed continuous effects of time, baseline FVC [mL], age, height, and including treatment-by-time and baseline-by-time interactions. Random effect was included for patient specific intercept and time. Within-patient errors were modelled by an unstructured variance-covariance matrix. Inter-individual variability was modelled by a variance-components variance-covariance matrix		

The effect of nintedanib in reducing the annual rate of decline in FVC was similar across pre-specified sensitivity analyses and no heterogeneity was detected in pre-specified subgroups (e.g. by age, gender, and mycophenolate use at baseline).

The changes from baseline in FVC (mL) over 52 weeks for both treatment groups are shown in Figure 2.

Figure 2 Mean (SEM) observed FVC change from baseline (mL) over 52 weeks, 1199.214

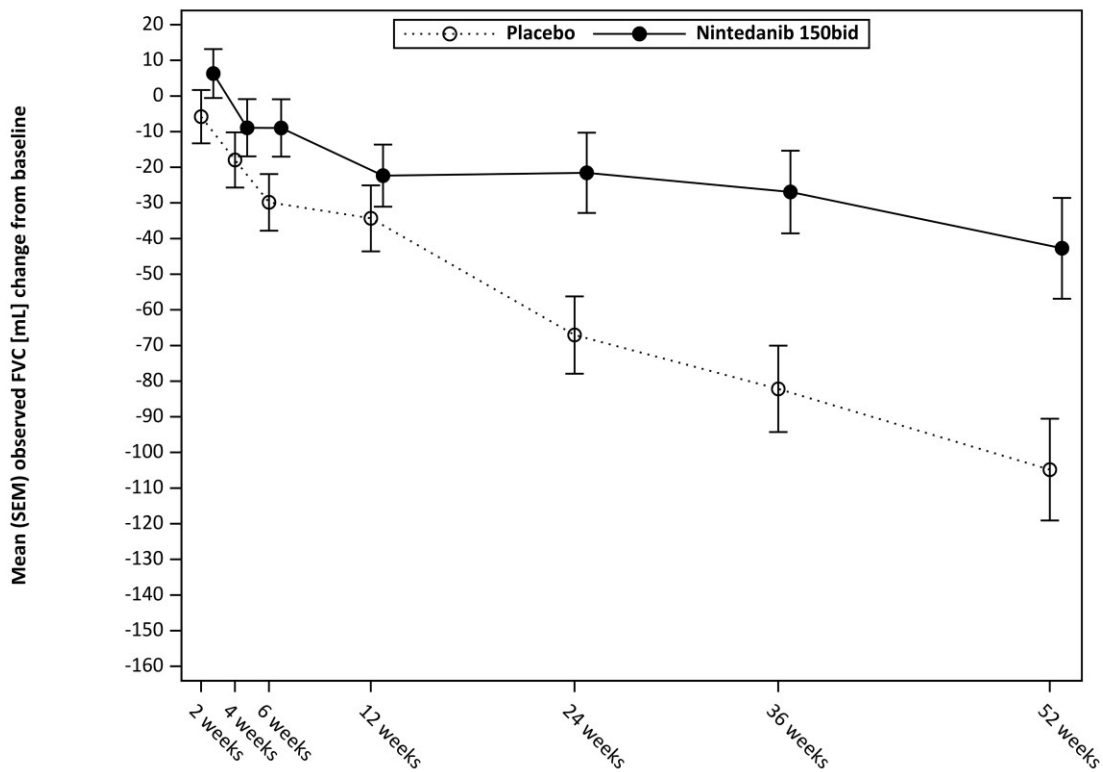

Number of patients	2 weeks	4 weeks	6 weeks	12 weeks	24 weeks	36 weeks	52 weeks
Placebo	283	281	280	283	280	268	257
Nintedanib 150bid	283	281	273	278	265	262	241

bid = twice daily

The adjusted annual rate of decline in FVC in % predicted over 52 weeks was lower in patients treated with OFEV (nintedanib) (-1.4%) compared with patients treated with placebo (-2.6%). This finding is consistent with that of the primary efficacy endpoint (i.e. the annual rate of decline in FVC in mL over 52 weeks).

Change from baseline in Modified Rodnan Skin Score (mRSS) at week 52

No benefit in mRSS was observed in patients receiving OFEV. The adjusted mean absolute change from baseline in mRSS at week 52 was comparable between the nintedanib group (-2.17 (95% CI -2.69, -1.65)) and the placebo group (-1.96 (95% CI -2.48, -1.45)). The adjusted mean difference between the treatment groups was -0.21 (95% CI -0.94, 0.53; p = 0.5785).

Change from baseline in St. George's Respiratory Questionnaire (SGRQ) total score at week 52

No benefit in SGRQ total score was observed in patients receiving OFEV. The adjusted mean absolute change from baseline in SGRQ total score at week 52 was comparable between the nintedanib group (0.81 (95% CI -0.92, 2.55)) and the placebo group (-0.88 (95% CI -2.58, 0.82)). The adjusted mean difference between the treatment groups was 1.69 (95% CI -0.73, 4.12; p = 0.1711).

Survival analysis

No difference in survival was observed in an exploratory analysis of mortality of the whole trial. Mortality over the whole trial was comparable between the nintedanib group (N = 10; 3.5%) and the placebo group (N = 9; 3.1%). The exploratory analysis of time to death over the whole trial resulted in a HR of 1.16 (95% CI 0.47, 2.84; p = 0.7535).

Other Chronic Fibrosing Interstitial Lung Diseases (ILDs) with a Progressive Phenotype

The clinical efficacy of nintedanib has been studied in patients with other chronic fibrosing ILDs with a progressive phenotype in a randomized, double-blind, placebo-controlled phase 3 trial (1199.247). Patients were randomized in a 1:1 ratio to receive either nintedanib 150 mg twice daily or matching placebo until the last patient completed the 52-week treatment period (nintedanib exposure over the whole trial: median 16.6 months; mean 15.0 months).

Randomization was stratified based on high resolution computed tomography (HRCT) fibrotic pattern as assessed by central readers: 412 patients with UIP-like HRCT pattern and 251 patients with other HRCT fibrotic patterns were randomized. There were 2 co-primary populations defined for the analyses in this trial: all patients (the overall population) and patients with HRCT with UIP-like HRCT fibrotic pattern. Patients with other HRCT fibrotic patterns represented the “complementary” population.

The primary endpoint was the annual rate of decline in FVC (in mL) over 52 weeks. Main secondary endpoints were absolute change from baseline in King's Brief Interstitial Lung Disease Questionnaire (K-BILD) total score at Week 52, time to first acute ILD exacerbation or death over 52 weeks, and time to death over 52 weeks.

Patients with a clinical diagnosis of a chronic fibrosing ILD were selected if they had relevant fibrosis (greater than 10% fibrotic features) on HRCT and presented with clinical signs of progression (defined as FVC decline $\geq 10\%$, FVC decline $\geq 5\%$ and $< 10\%$ with worsening symptoms or increased fibrotic changes on chest imaging, or worsening symptoms and increased fibrotic changes on chest imaging, all in the 24 months prior to screening). Patients were required to have an FVC greater than or equal to 45% of predicted and a DLCO 30-80% of predicted. Patients with IPF, relevant airways obstruction (i.e., pre-bronchodilator FEV1/FVC less than 0.7), or significant pulmonary hypertension were excluded from the trial. Patients with greater than 1.5 times ULN of ALT, AST, or bilirubin, patients with a known risk or predisposition to bleeding, patients receiving a full dose of anticoagulation treatment, and patients with a recent history of myocardial infarction or stroke were excluded. Patients were also excluded if they received other investigational therapy, previous treatment with nintedanib or pirfenidone, azathioprine, cyclosporine, mycophenolate mofetil, tacrolimus, oral corticosteroids greater than 20 mg/day, or the combination of oral corticosteroids + azathioprine + n-acetylcysteine within 4 weeks of randomization, cyclophosphamide within 8 weeks prior to randomization, or rituximab within 6 months.

The majority of patients were Caucasian (74%) or Asian (25%). Patients were mostly male (54%) and had a mean age of 66 years and a mean FVC percent predicted of 69%. The underlying clinical ILD diagnoses in groups represented in the trial were hypersensitivity

pneumonitis (26%), autoimmune ILDs (26%), idiopathic nonspecific interstitial pneumonia (19%), unclassifiable idiopathic interstitial pneumonia (17%), and other ILDs (12%).

Study demographics and trial design

Table 9 Summary of patient demographics in trial 1199.247

Study #	Trial design	Dosage, route of administration and duration	Study subjects (n=number)	Mean age (Standard Deviation (StD))	Gender
1199.247	Multicentre, randomized, double-blind	Eligible patients were randomized in 1:1 ratio to receive nintedanib 150 mg bid or placebo for at least 52 weeks.	Nintedanib: n=332 Placebo: n=331	65.8 (StD 9.8 years)	54% male and 75% female

Study results

Annual rate of decline in FVC

The annual rate of decline in FVC (in mL) over 52 weeks was significantly reduced by 107.0 mL in patients receiving nintedanib compared to patients receiving placebo (Table 10) corresponding to a relative treatment effect of 57.0%. Similar results were observed in the co-primary population of patients with HRCT with UIP-like fibrotic pattern with a difference between treatment groups of 128.2 mL/year. Further, the treatment effect was consistent in the complementary population of patients with other HRCT fibrotic patterns.

Table 10 Annual rate of decline in FVC (mL) in trial 1199.247

	Overall population		Subpopulation UIP-like		Subpopulation Other HRCT fibrotic patterns	
	Placebo	Nintedanib 150 mg twice daily	Placebo	Nintedanib 150 mg twice daily	Placebo	Nintedanib 150 mg twice daily
Number of analyzed patients	331	332	206	206	125	126
Rate ^a (SE) of decline over 52 weeks	-187.8	-80.8	-211.1	-82.9	-154.2	-79.0
Comparison vs placebo difference ^a	107.0		128.2		75.2	
95% CI	(65.4, 148.5)		(70.8, 185.6)		(15.5, 135.0)	
p-value	< 0.0001		< 0.0001			

^aBased on a random coefficient regression model with fixed categorical effects of treatment, HRCT pattern, fixed continuous effects of time, baseline FVC (mL), and including treatment by time and baseline by time interactions

The effect of nintedanib in reducing the annual rate of decline in FVC was generally consistent in all pre-specified subgroups (e.g., gender, age group, race, baseline FVC percent predicted, and original underlying clinical ILD diagnosis in groups). An analysis by ILD diagnosis was performed and is shown in Figure 3. A limited number of patients with representative diagnoses related to this indication were evaluated. Study 1199.247 was not designed or powered to provide evidence for a benefit of nintedanib in specific diagnostic subgroups. Consistent effects were demonstrated in subgroups based on the ILD diagnoses. The experience with nintedanib in very rare progressive fibrosing ILDs is limited.

Figure 3 Forest plot of the annual rate of decline in FVC [mL/yr] over 52 weeks by underlying ILD diagnosis in groups.

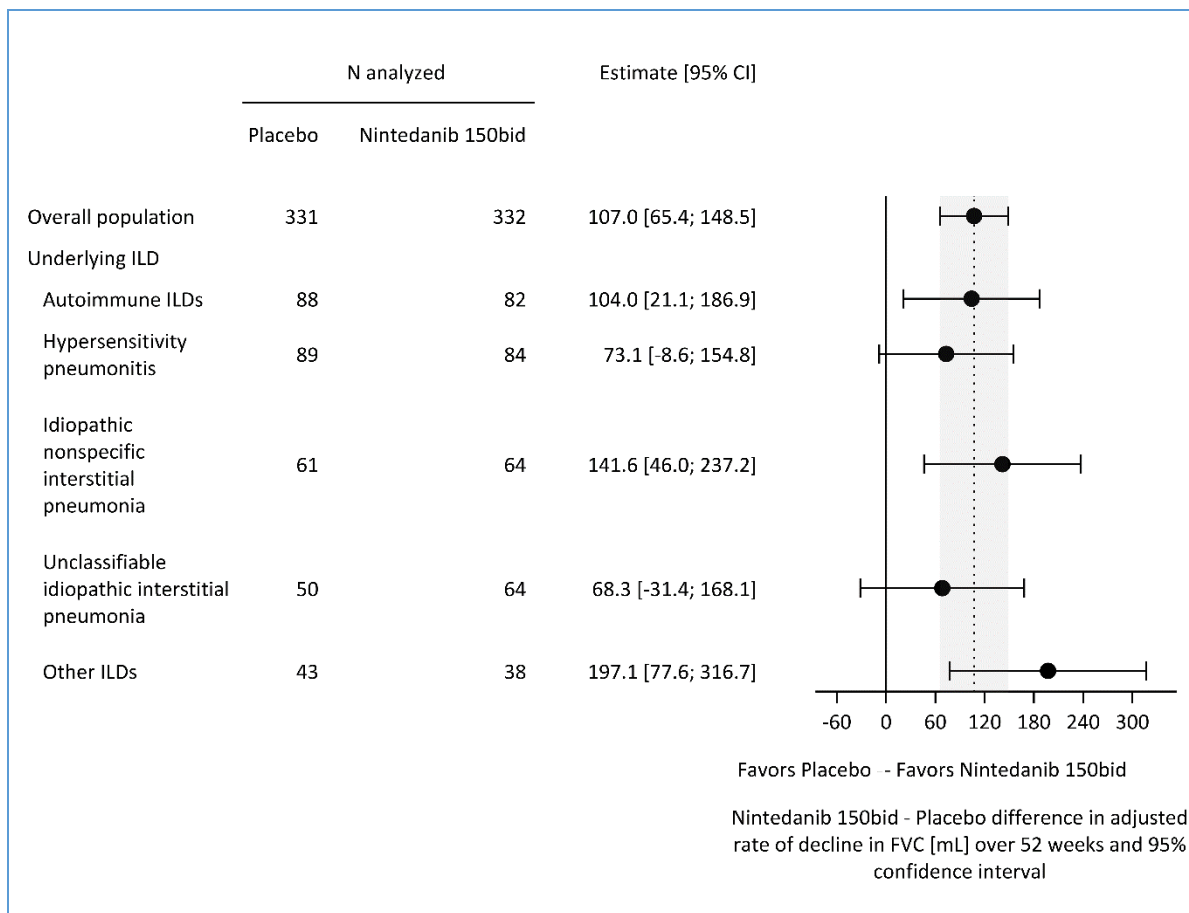

bid = twice daily

Figure 4 shows the evolution of change in FVC from baseline over time in the treatment groups. When the mean observed FVC change from baseline was plotted over time, the curves diverged at all timepoints through Week 52.

Figure 4 Mean (SEM) observed FVC change from baseline (mL) over 52 weeks in trial 1199.247

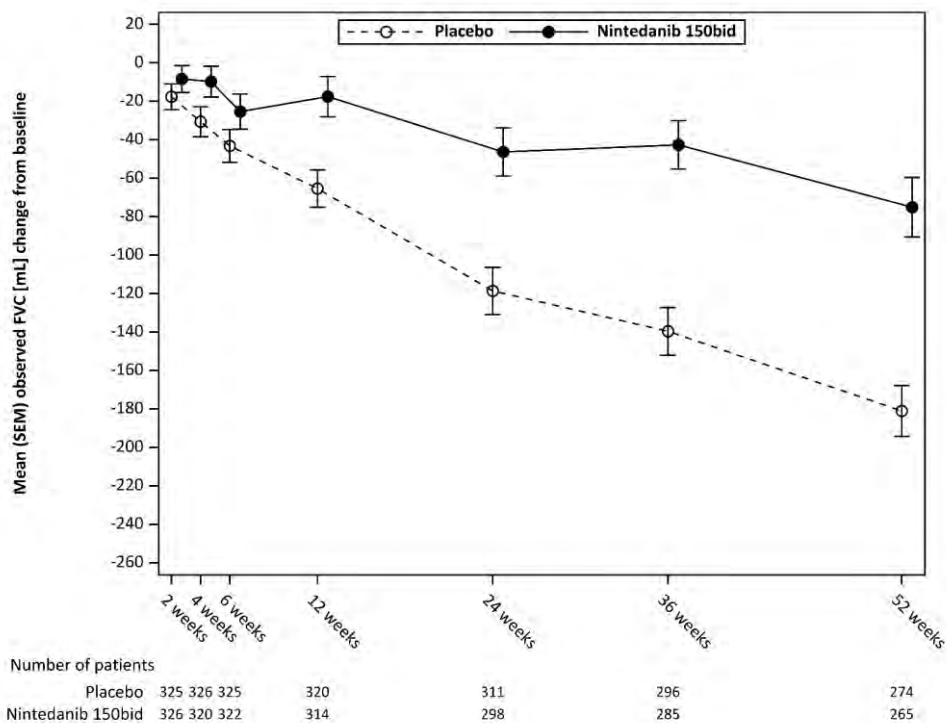

bid = twice daily

In addition, favorable effects of nintedanib were observed on the adjusted mean change from baseline in FVC percent predicted at Week 52. The adjusted mean absolute change from baseline to Week 52 in FVC percent predicted was lower in the nintedanib group (-2.62%) than in the placebo group (-5.86%). The adjusted mean difference between the treatment groups was 3.24% (95% CI: 2.09, 4.40).

Time to first acute ILD exacerbation or death

Acute ILD exacerbations were defined as unexplained worsening or development of dyspnea within a 30 day period, new diffuse pulmonary infiltrates on chest x-ray, and/or new HRCT parenchymal abnormalities with no pneumothorax or pleural effusion, and exclusion of alternative causes. Acute ILD exacerbations were not adjudicated. The proportion of patients with at least one event of this exploratory composite endpoint over 52 weeks was 7.8% in the nintedanib group and 9.7% in the placebo group (HR 0.80 (95% CI: 0.48, 1.34)). When analyzing data over the whole trial, the risk of first acute ILD exacerbation or death decreased in the nintedanib group compared with the placebo group (HR 0.67 (95% CI: 0.46, 0.98)).

Survival

An exploratory analysis of all-cause mortality did not show a statistically significant difference. The proportion of patients who died over 52 weeks was 4.8% in the nintedanib group compared to 5.1% in the placebo group. The HR was 0.94 (95% CI: 0.47, 1.86). Over the whole trial the HR was 0.78 (95% CI: 0.504, 1.21).

Quality of life

The adjusted mean change from baseline in King's Brief Interstitial Lung Disease Questionnaire total score at week 52, analyzed as an exploratory endpoint, was -0.79 units in the placebo group and 0.55 in the nintedanib group (scored from 0-100, with higher scores indicating a better health status). The difference between the treatment groups was 1.34 (95% CI: -0.31, 2.98).

DETAILED PHARMACOLOGY

Nintedanib exerted anti-inflammatory and anti-fibrotic activity in three animal models of bleomycin- or silica-induced pulmonary fibrosis. Anti-inflammatory activity was demonstrated by reduced lymphocytes and neutrophils in the bronchoalveolar lavage, by attenuated interleukin (IL)-1 β , IL-6, CXCL1/KC levels in lung tissue and by reduced inflammatory scores in lung histology. Anti-fibrotic activity was shown by reduced procollagen-1 mRNA expression and total collagen and tissue inhibitor of metalloproteinase 1 levels in lung tissue and reduced fibrotic scores in lung histology.

TOXICOLOGY

General toxicology

Single dose toxicity studies in rats and mice indicated a low acute toxic potential of nintedanib. In repeat dose toxicology studies in rats, adverse effects (e.g. thickening of epiphyseal plates, lesions of the incisors) were mostly related to the mechanism of action (i.e. VEGFR-2 inhibition) of nintedanib. These changes are known from other VEGFR-2 inhibitors and can be considered class effects.

Diarrhea and vomiting accompanied by reduced food consumption and loss of body weight were observed in toxicity studies in non-rodents.

There was no evidence of liver enzyme increases in rats, dogs, and Cynomolgus monkeys. Mild liver enzyme increases which were not due to serious adverse effects such as diarrhea were only observed in Rhesus monkeys.

Reproduction toxicity

In rats, nintedanib reduced female fertility, including increases in resorption and post-implantation loss, at exposures below the maximum recommended human dose (MRHD) of 150 mg b.i.d. based on AUC. A decrease in the number and size of corpora lutea in the ovaries was observed in chronic toxicity studies in rats and mice.

In rats, embryo-fetal lethality and teratogenic effects were observed at an exposure approximately 3.6 to 7.2 times lower than at the MRHD. At an exposure of approximately 12 to 18 times lower than the exposure at the MRHD, slight effects on the development of the axial skeleton and on the development of the great arteries were noted.

In rabbits, embryo-fetal lethality and teratogenic effects were observed at an exposure approximately 3 times higher than at the MRHD but equivocal effects on the embryo-fetal development of the axial skeleton and the heart were noted already at an exposure below that at the MRHD of 150 mg twice daily.

A study of male fertility and early embryonic development up to implantation in rats did not reveal effects on the male reproductive tract and male fertility.

In rats, small amounts of radiolabelled nintedanib and/or its metabolites were excreted into the milk (≤ 0.5 % of the administered dose).

Carcinogenicity

From the 2-year carcinogenicity studies in mice and rats, there was no evidence for a carcinogenic potential of nintedanib. Nintedanib was dosed up to 10 mg/kg/day in rats and 30 mg/kg/day in mice. These doses were less than (in rats) and approximately 4 times (in mice) the MRHD based on plasma drug AUC.

Genotoxicity

Nintedanib was negative for genotoxicity in the *in vitro* bacterial reverse mutation assay, the mouse lymphoma assay, and the *in vivo* rat micronucleus assay.

REFERENCES

1. Collard HR, et al. Suspected acute exacerbation of idiopathic pulmonary fibrosis as an outcome measure in clinical trials. *Respir Res* 2013;14:73.
2. Distler O et al., Nintedanib for Systemic Sclerosis –Associated Interstitial Lung Disease. *N Engl J Med* 2019; 380:2518-28.
3. du Bois RM, et al. Forced Vital Capacity in Patients with Idiopathic Pulmonary Fibrosis. *Am J Resp Crit Care Med* 2011; 184: 1382-1389.
4. Flaherty KR, Wells AU Cottin V, et al. Nintedanib in Progressive Fibrosing Interstitial Lung Diseases. *N Engl J Med* 2019; DOI: 10.1056/Moa1908681.
5. Hostettler KE, Zhong J, Papakonstantinou E, et al. Anti-fibrotic effects of nintedanib in lung fibroblasts derived from patients with idiopathic pulmonary fibrosis. *Resp Res* 2014;15:157-65.
6. Ley B, et al. Clinical course and prediction of survival in idiopathic pulmonary fibrosis. *Am J Respir Crit Care Med* 2011;183(4):431-40.
7. Mazzei ME, Richeldi L, Collard HR. Nintedanib in the treatment of idiopathic pulmonary fibrosis. *Ther Adv Resp Dis* 2015;9(3):121-9.
8. Richeldi L, Costabel U, Selman M, et al. Efficacy of a tyrosine kinase inhibitor in idiopathic pulmonary fibrosis. *N Engl J Med* 2011;365(12): 1079-87.
9. Richeldi L, du Boi RM, Raghu G, et al. Efficacy and safety of nintedanib in idiopathic pulmonary fibrosis. *N Engl J Med* 2014;370:2071-82.
10. Song JW, et al. Acute exacerbation of idiopathic pulmonary fibrosis: incidence, risk factors and outcome. *Eur Respir J* 2011;37:356-63.
11. Supplementary Appendix to: Richeldi L, du Boi RM, Raghu G, et al. Efficacy and safety of nintedanib in idiopathic pulmonary fibrosis. *N Engl J Med* 2014;370:2071-82.
12. Wollin L, et al. Mode of action of nintedanib in the treatment of idiopathic pulmonary fibrosis. *Eur Resp J* 2015;45:1434-45.

PART III: CONSUMER INFORMATION

PrOfev®
Nintedanib Capsules

Read this carefully before you start taking OFEV and each time you get a refill. This leaflet is a summary and will not tell you everything about this drug. Talk to your healthcare professional about your medical condition and treatment and ask if there is any new information about OFEV.

ABOUT THIS MEDICATION

What the medication is used for:

Use OFEV to treat adults with:

- Idiopathic Pulmonary Fibrosis (IPF);
- To slow the rate of decline in pulmonary function in patients with Systemic Sclerosis associated Interstitial Lung Disease (SSc-ILD) (scleroderma lung disease);
- Interstitial Lung Diseases (ILDs) where lung fibrosis continues to worsen (progress). May also be known as progressive fibrosing ILD (PF-ILD).

What it does:

OFEV works to reduce the fibrosis in your lungs.

When it should not be used:

- If you are allergic to nintedanib, peanut or soya, or any of the other ingredients in OFEV.
- If you are pregnant, think you may be pregnant or are planning to have a baby, speak with your doctor before starting OFEV.
- Do not take OFEV during pregnancy. If you are pregnant, speak with your doctor before you decide to stop taking OFEV. It may cause birth defects.
- If you are younger than 18 years of age.

What the medicinal ingredient is:

Nintedanib esilate

What the non-medicinal ingredients are:

Gelatin, glycerol, hard fat, iron oxide black, iron oxide red, iron oxide yellow, medium chain triglycerides, propylene glycol, shellac glaze, soya lecithin, titanium dioxide

What dosage forms it comes in:

Capsules: 100 mg and 150 mg

WARNINGS AND PRECAUTIONS

BEFORE you use OFEV, talk to your doctor or pharmacist if you:

- have or had liver problems;
- have or had bleeding problems;
- have high blood pressure and its complications, including separation of the layers of the arterial wall (Artery Dissection);
- have or had peptic ulcers;
- take blood-thinning medicines to prevent blood clotting;

- have or had problems with your heart;
- recently had surgery or will be having surgery;
- are pregnant or planning to become pregnant;
- are taking NSAIDs or corticosteroids.

Serious Liver Problems: In some patients, OFEV has been associated with drug-induced liver injuries (DILIs), in rare cases these can be serious and life-threatening. Before and during treatment, your doctor should do blood tests, for example to check your liver function, to determine if you may be treated with OFEV.

Stop taking OFEV and inform your doctor immediately if you have unexplained symptoms such as yellowing of your skin or the white part of your eyes (jaundice), dark or brown (tea coloured) urine, pain on the upper right side of your stomach area (abdomen), bleeding or bruising more easily than normal, nausea, vomiting or loss of appetite, or feeling tired.

While taking OFEV, tell your doctor immediately if you:

- experience diarrhea. It is important to treat diarrhea early;
- vomit or have nausea;
- experience severe abdominal pain and swelling, nausea, vomiting, chills and fever as these could be symptoms of a hole in the wall of your gut (gastrointestinal perforation);
- experience swelling, redness and pain in one part of the body as these could be symptoms of a blood clot;
- experience chest pressure or pain, in the centre of the chest or spread over the shoulder or arm, a fast heartbeat, shortness of breath, nausea or vomiting, as these could be symptoms of a heart attack;
- have any bleeding that does not stop.

Birth Control: Women of childbearing age must use highly effective birth control while taking OFEV and for at least 3 months after the last dose. Women who use any form of hormonal contraceptives must also add a barrier method. Tell your doctor or pharmacist right away if you become pregnant or think you are pregnant while taking OFEV.

Breastfeeding / Lactation:

Do not breastfeed. OFEV may harm the infant.

Driving and using machines: Before doing tasks that require special attention, wait until you know how you respond to OFEV.

INTERACTIONS WITH THIS MEDICATION

As with most medicines, interactions with other drugs are possible. Tell your doctor, nurse, or pharmacist about **all** the medicines you take, including drugs prescribed by other doctors, vitamins, minerals, natural supplements, or alternative medicines.

The following may interact with OFEV:

- Ketoconazole used to treat fungal infections;
- Erythromycin used to treat bacterial infections;
- Rifampicin, an antibiotic used to treat tuberculosis;
- Carbamazepine or phenytoin used to treat seizures;

- St. John's Wort, a herbal medicine;
- Grapefruits, grapefruit juice or Seville oranges.

PROPER USE OF THIS MEDICATION

OFEV should only be prescribed and monitored by physicians experienced in the diagnosis and treatment of the conditions for which OFEV is indicated.

Swallow the capsule **whole** with water. DO NOT chew or crush the capsule.

Take OFEV:

- exactly as prescribed;
- every day;
- every 12 hours, at about the same time every day;
- with food.

Usual Adult Dose:

Recommended and maximum daily dose is 150 mg twice a day.

For patients with mild liver disease the recommended daily dose is 100 mg twice a day.

Your doctor probably will not prescribe OFEV if you have moderate or severe liver disease.

If you have side effects, your doctor may:

- decrease your dose to 100 mg twice a day; or
- advise you to interrupt temporarily or stop taking OFEV.

Do not reduce the dose or stop taking OFEV without consulting your doctor. It is important to take OFEV every day, as long as your doctor prescribes it for you.

Do not take more than the maximum daily dose.

Overdose:

In case of drug overdose, contact a healthcare practitioner, hospital emergency department or regional Poison Control Centre immediately, even if there are no symptoms.

Missed Dose:

If you have forgotten to take your dose, carry on and take your next dose at the usual time. Do not double dose.

SIDE EFFECTS AND WHAT TO DO ABOUT THEM

As with all medicines, patients using OFEV may experience side effects, although not everybody gets them.

Side effects may include:

- Diarrhea, which may lead to a loss of fluid and important

electrolytes in your body. At the first signs of diarrhea, drink plenty of fluids and start anti-diarrheal treatment. In most patients, diarrhea was of mild to moderate intensity and occurred within the first 3 months of treatment;

- Nausea and vomiting; in most patients, nausea and vomiting was of mild to moderate intensity;
- Abdominal pain;
- Areas of hair loss;
- Bleeding;
- Constipation;
- Dizziness;
- Decreased appetite;
- Gas;
- Headache;
- Heartburn;
- Musculoskeletal pain;
- Weight decrease.

OFEV can cause abnormal blood test results. Your doctor will do blood tests regularly to check how well your liver function is working during your treatment. Your doctor will decide when to perform blood tests and will interpret the results.

If any of these affects you severely, tell your doctor, nurse or pharmacist.

SERIOUS SIDE EFFECTS, HOW OFTEN THEY HAPPEN AND WHAT TO DO ABOUT THEM				
Symptom / effect		Talk with your Health Care Professional		Stop taking drug and get immediate medical help
		Only if severe	In all cases	
Very Common	Diarrhea		✓	
	Nausea	✓		
	Abdominal pain		✓	
Common	Vomiting		✓	
	Decreased weight	✓		
	Decreased appetite	✓		
	Bleeding			✓
Uncommon	Serious liver problems or Jaundice: increased blood bilirubin and liver enzymes levels (liver test), yellowing of the skin or the white part of the eyes, dark or brown (tea coloured) urine, abdominal pain, nausea, vomiting, loss of appetite, bleeding or bruising more easily than normal, or feeling tired			✓
	Hypertension (blood pressure increased): headache, vision disorders, nausea and vomiting	✓		
	Gastrointestinal perforation: severe constant abdominal pain with tenderness, distension, nausea and vomiting			✓
	Heart Attack: pain in the chest or spread over the shoulder or arm; a fast heartbeat; shortness of breath; nausea or vomiting			✓

SERIOUS SIDE EFFECTS, HOW OFTEN THEY HAPPEN AND WHAT TO DO ABOUT THEM				
Symptom / effect		Talk with your Health Care Professional		Stop taking drug and get immediate medical help
		Only if severe	In all cases	
Uncommon	Pancreatitis: severe upper abdominal pain radiating to the back, fever, nausea and vomiting		✓	
	Thrombocytopenia: easily bruised, rash with reddish-purplish spots usually on the lower legs, longer than usual bleeding from a cut, bleeding from your gums or nose, bleeding in urine or in your stool (black like tar stool), fatigue		✓	
	Rash/itchy skin	✓		
Very rare	Artery Dissection: sudden severe pain in the back, chest or abdomen			✓
	Artery Aneurysm (a bulge in the wall of any artery including in the chest, arms, legs, heart, and brain): symptoms will differ by the site, they can be cough, coughing up blood, strong pain high in your neck or in your back when you didn't hurt yourself, problems swallowing, hoarse voice, unusual pulsing in your chest or abdomen			✓

This is not a complete list of side effects. For any unexpected effects while taking OFEV, contact your doctor or pharmacist.

HOW TO STORE IT

Keep out of the sight and reach of children.

Do not use this medicine after the expiry date which is stated on carton.

Store at 15-25°C. Store in the original blister in order to protect from moisture.

Do not use this medicine if you notice that the blister containing the capsules is opened or a capsule is broken.

Do not throw away any medicines via wastewater or household waste. Ask your pharmacist how to throw away medicines you no longer use. These measures will help protect the environment.

Reporting Side Effects

You can report any suspected side effects associated with the use of health products to Health Canada by:

- Visiting the Web page on Adverse Reaction Reporting (<https://www.canada.ca/en/health-canada/services/drugs-health-products/medeffect-canada/adverse-reaction-reporting.html>) for information on how to report online, by mail or by fax; or
- Calling toll-free at 1-866-234-2345.

NOTE: Contact your health professional if you need information about how to manage your side effects. The Canada Vigilance Program does not provide medical advice.

MORE INFORMATION

If you want more information about OFEV:

- Talk to your healthcare professional.
- Find the full product monograph that is prepared for healthcare professionals and includes this Consumer Information by visiting the Health Canada website (<https://health-products.canada.ca/dpd-bdpp/index-eng.jsp>), the manufacturer's website (<https://www.boehringer-ingelheim.ca>), or by calling the manufacturer, Boehringer Ingelheim (Canada) Ltd., at: 1-800-263-5103, extension 84633.

This leaflet was prepared by Boehringer Ingelheim (Canada) Ltd. The information in this leaflet is current up to the time of the last revision date shown below, but more current information may be available from the manufacturer.

Last revised: May 19, 2020

HIGHLIGHTS OF PRESCRIBING INFORMATION

These highlights do not include all the information needed to use OFEV safely and effectively. See full prescribing information for OFEV.

OFEV[®] (nintedanib) capsules, for oral use
Initial U.S. Approval: 2014

RECENT MAJOR CHANGES

Indications and Usage (1)	3/2020
Dosage and Administration, Testing Prior to OFEV Administration (2.1)	9/2019
Warnings and Precautions (5)	3/2020

INDICATIONS AND USAGE

OFEV is a kinase inhibitor indicated for:

- Treatment of idiopathic pulmonary fibrosis (IPF). (1.1)
- Treatment of chronic fibrosing interstitial lung diseases (ILDs) with a progressive phenotype (1.2)
- Slowing the rate of decline in pulmonary function in patients with systemic sclerosis-associated interstitial lung disease (SSc-ILD). (1.3)

DOSAGE AND ADMINISTRATION

- Recommended dosage: 150 mg twice daily approximately 12 hours apart taken with food. (2.2)
- Recommended dosage in patients with mild hepatic impairment (Child Pugh A): 100 mg twice daily approximately 12 hours apart taken with food. (2.2, 8.6)
- Consider temporary dose reduction to 100 mg, treatment interruption, or discontinuation for management of adverse reactions. (2.3, 5.2, 5.3, 6)
- Prior to treatment initiation, conduct liver function tests in all patients and a pregnancy test in females of reproductive potential. (2.1, 5.2, 5.4)

DOSAGE FORMS AND STRENGTHS

Capsules: 150 mg and 100 mg (3)

CONTRAINDICATIONS

None (4)

WARNINGS AND PRECAUTIONS

- Hepatic impairment: OFEV is not recommended for use in patients with moderate or severe hepatic impairment. In patients with mild hepatic impairment (Child Pugh A), the recommended dosage is 100 mg twice daily approximately 12 hours apart taken with food. Consider treatment interruption, or discontinuation for management of adverse reactions in these patients. (2.2, 2.3, 5.1, 8.6, 12.3)
- Elevated liver enzymes and drug-induced liver injury: ALT, AST, and bilirubin elevations have occurred with OFEV, including cases of drug-induced liver injury. In the postmarketing period, non-serious and serious cases of drug-induced liver injury, including severe liver injury with fatal outcome, have been reported. The majority of hepatic events occur within the first three months of treatment. Liver enzyme and bilirubin increases were reversible with dose modification or interruption in the majority of

cases. Monitor ALT, AST, and bilirubin prior to initiation of treatment, at regular intervals during the first three months of treatment, and periodically thereafter or as clinically indicated. Temporary dosage reductions or discontinuations may be required. (2.1, 2.3, 5.2)

- Gastrointestinal disorders: Diarrhea, nausea, and vomiting have occurred with OFEV. Treat patients at first signs with adequate hydration and antidiarrheal medicine (e.g., loperamide) or anti-emetics. Discontinue OFEV if severe diarrhea, nausea, or vomiting persists despite symptomatic treatment. (5.3)
- Embryo-Fetal toxicity: Can cause fetal harm. Advise females of reproductive potential of the potential risk to a fetus and to use highly effective contraception. As the impact of nintedanib on the effectiveness of hormonal contraception is unknown, advise women using hormonal contraceptives to add a barrier method. (5.4, 8.1, 8.3)
- Arterial thromboembolic events have been reported. Use caution when treating patients at higher cardiovascular risk including known coronary artery disease. (5.5)
- Bleeding events have been reported. Use OFEV in patients with known bleeding risk only if anticipated benefit outweighs the potential risk. (5.6)
- Gastrointestinal perforation has been reported. Use OFEV with caution when treating patients with recent abdominal surgery, previous history of diverticular disease or receiving concomitant corticosteroids or NSAIDs. Discontinue OFEV in patients who develop gastrointestinal perforation. Only use OFEV in patients with known risk of gastrointestinal perforation if the anticipated benefit outweighs the potential risk. (5.7)

ADVERSE REACTIONS

Most common adverse reactions ($\geq 5\%$) are: diarrhea, nausea, abdominal pain, vomiting, liver enzyme elevation, decreased appetite, headache, weight decreased, and hypertension. (6.1)

To report SUSPECTED ADVERSE REACTIONS, contact Boehringer Ingelheim Pharmaceuticals, Inc. at (800) 542-6257 or (800) 459-9906 TTY or FDA at 1-800-FDA-1088 or www.fda.gov/medwatch.

DRUG INTERACTIONS

- Coadministration of P-gp and CYP3A4 inhibitors may increase nintedanib exposure. Monitor patients closely for tolerability of OFEV. (7.1)

USE IN SPECIFIC POPULATIONS

- Lactation: Breastfeeding is not recommended. (8.2)
- Renal impairment: The safety and efficacy of OFEV have not been studied in patients with severe renal impairment and end-stage renal disease. (8.7, 12.3)
- Smokers: Decreased exposure has been noted in smokers which may alter the efficacy profile of OFEV. (8.8)

See 17 for PATIENT COUNSELING INFORMATION and FDA-approved patient labeling.

Revised: 3/2020

FULL PRESCRIBING INFORMATION: CONTENTS*

1 INDICATIONS AND USAGE

- 1.1 Idiopathic Pulmonary Fibrosis
- 1.2 Chronic Fibrosing Interstitial Lung Diseases with a Progressive Phenotype
- 1.3 Systemic Sclerosis-Associated Interstitial Lung Disease

2 DOSAGE AND ADMINISTRATION

- 2.1 Testing Prior to OFEV Administration
- 2.2 Recommended Dosage
- 2.3 Dosage Modification due to Adverse Reactions

3 DOSAGE FORMS AND STRENGTHS

4 CONTRAINDICATIONS

5 WARNINGS AND PRECAUTIONS

- 5.1 Hepatic Impairment
- 5.2 Elevated Liver Enzymes and Drug-Induced Liver Injury
- 5.3 Gastrointestinal Disorders
- 5.4 Embryo-Fetal Toxicity
- 5.5 Arterial Thromboembolic Events
- 5.6 Risk of Bleeding
- 5.7 Gastrointestinal Perforation

6 ADVERSE REACTIONS

- 6.1 Clinical Trials Experience
- 6.2 Postmarketing Experience

7 DRUG INTERACTIONS

- 7.1 P-glycoprotein (P-gp) and CYP3A4 Inhibitors and Inducers
- 7.2 Anticoagulants
- 7.3 Pirfenidone
- 7.4 Bosentan

8 USE IN SPECIFIC POPULATIONS

- 8.1 Pregnancy
- 8.2 Lactation
- 8.3 Females and Males of Reproductive Potential
- 8.4 Pediatric Use
- 8.5 Geriatric Use
- 8.6 Hepatic Impairment
- 8.7 Renal Impairment
- 8.8 Smokers

10 OVERDOSAGE

11 DESCRIPTION

12 CLINICAL PHARMACOLOGY

12.1 Mechanism of Action

12.2 Pharmacodynamics

12.3 Pharmacokinetics

13 NONCLINICAL TOXICOLOGY

13.1 Carcinogenesis, Mutagenesis, Impairment of Fertility

14 CLINICAL STUDIES

14.1 Idiopathic Pulmonary Fibrosis

14.2 Chronic Fibrosing Interstitial Lung Diseases with a Progressive Phenotype

14.3 Systemic Sclerosis-Associated Interstitial Lung Disease

16 HOW SUPPLIED/STORAGE AND HANDLING

17 PATIENT COUNSELING INFORMATION

*Sections or subsections omitted from the full prescribing information are not listed.

FULL PRESCRIBING INFORMATION

1 INDICATIONS AND USAGE

1.1 Idiopathic Pulmonary Fibrosis

OFEV is indicated for the treatment of idiopathic pulmonary fibrosis (IPF).

1.2 Chronic Fibrosing Interstitial Lung Diseases with a Progressive Phenotype

OFEV is indicated for the treatment of chronic fibrosing interstitial lung diseases (ILDs) with a progressive phenotype [see *Clinical Studies (14.2)*].

1.3 Systemic Sclerosis-Associated Interstitial Lung Disease

OFEV is indicated to slow the rate of decline in pulmonary function in patients with systemic sclerosis-associated interstitial lung disease (SSc-ILD).

2 DOSAGE AND ADMINISTRATION

2.1 Testing Prior to OFEV Administration

Conduct liver function tests in all patients and a pregnancy test in females of reproductive potential prior to initiating treatment with OFEV [see *Warnings and Precautions (5.2, 5.4)*].

2.2 Recommended Dosage

The recommended dosage of OFEV is 150 mg twice daily administered approximately 12 hours apart.

OFEV capsules should be taken with food [see *Clinical Pharmacology (12.3)*] and swallowed whole with liquid. OFEV capsules should not be chewed or crushed because of a bitter taste. The effect of chewing or crushing of the capsule on the pharmacokinetics of nintedanib is not known.

If a dose of OFEV is missed, the next dose should be taken at the next scheduled time. Advise the patient to not make up for a missed dose. Do not exceed the recommended maximum daily dosage of 300 mg.

In patients with mild hepatic impairment (Child Pugh A), the recommended dosage of OFEV is 100 mg twice daily approximately 12 hours apart taken with food.

2.3 Dosage Modification due to Adverse Reactions

In addition to symptomatic treatment, if applicable, the management of adverse reactions of OFEV may require dose reduction or temporary interruption until the specific adverse reaction resolves to levels that allow continuation of therapy. OFEV treatment may be resumed at the full dosage (150 mg twice daily), or at the reduced dosage (100 mg twice daily), which subsequently may be increased to the full dosage. If a patient does not tolerate 100 mg twice daily, discontinue treatment with OFEV [see *Warnings and Precautions (5.2, 5.3, 5.5, 5.7) and Adverse Reactions (6.1)*].

Dose modifications or interruptions may be necessary for liver enzyme elevations. Conduct liver function tests (aspartate aminotransferase (AST), alanine aminotransferase (ALT), and bilirubin) prior to initiation of treatment with OFEV, at regular intervals during the first three months of treatment, and periodically thereafter or as clinically indicated. Measure liver tests promptly in patients who report symptoms that may indicate liver injury, including fatigue, anorexia, right upper abdominal discomfort, dark urine or jaundice. Discontinue OFEV in patients with AST or ALT greater than 3 times the upper limit of normal (ULN) with signs or symptoms of liver injury and for AST or ALT elevations greater than 5 times the upper limit of normal. For AST or ALT greater than 3 times to less than 5 times the ULN without signs of liver damage, interrupt treatment or reduce OFEV to 100 mg twice daily. Once liver enzymes have returned to baseline values, treatment with OFEV may be reintroduced at a reduced dosage (100 mg twice daily), which subsequently may

be increased to the full dosage (150 mg twice daily) [*see Warnings and Precautions (5.2) and Adverse Reactions (6.1)*].

In patients with mild hepatic impairment (Child Pugh A), consider treatment interruption, or discontinuation for management of adverse reactions.

3 DOSAGE FORMS AND STRENGTHS

150 mg capsules: brown, opaque, oblong, soft capsules imprinted in black with the Boehringer Ingelheim company symbol and "150".

100 mg capsules: peach, opaque, oblong, soft capsules imprinted in black with the Boehringer Ingelheim company symbol and "100".

4 CONTRAINDICATIONS

None

5 WARNINGS AND PRECAUTIONS

5.1 Hepatic Impairment

Treatment with OFEV is not recommended in patients with moderate (Child Pugh B) or severe (Child Pugh C) hepatic impairment [*see Use in Specific Populations (8.6) and Clinical Pharmacology (12.3)*]. Patients with mild hepatic impairment (Child Pugh A) can be treated with a reduced dose of OFEV [*see Dosage and Administration (2.2)*].

5.2 Elevated Liver Enzymes and Drug-Induced Liver Injury

Cases of drug-induced liver injury (DILI) have been observed with OFEV treatment. In the clinical trials and postmarketing period, non-serious and serious cases of DILI were reported. Cases of severe liver injury with fatal outcome have been reported in the postmarketing period. The majority of hepatic events occur within the first three months of treatment. In clinical trials, administration of OFEV was associated with elevations of liver enzymes (ALT, AST, ALKP, GGT) and bilirubin. Liver enzyme and bilirubin increases were reversible with dose modification or interruption in the majority of cases. In IPF studies (Study 1, Study 2, and Study 3), the majority (94%) of patients with ALT and/or AST elevations had elevations less than 5 times ULN and the majority (95%) of patients with bilirubin elevations had elevations less than 2 times ULN. In the chronic fibrosing ILDs with a progressive phenotype study (Study 5), the majority (95%) of patients with ALT and/or AST elevations had elevations less than 5 times ULN and the majority (94%) of patients with bilirubin elevations had elevations less than 2 times ULN. In the SSc-ILD study (Study 4), a maximum ALT and/or AST greater than or equal to 3 times ULN was observed for 4.9% of patients in the OFEV group and for 0.7% of patients in the placebo group [*see Use in Specific Populations (8.6) and Clinical Pharmacology (12.3)*]. Patients with a low body weight (less than 65 kg), Asian, and female patients may have a higher risk of elevations in liver enzymes. Nintedanib exposure increased with patient age, which may also result in a higher risk of increased liver enzymes [*see Clinical Pharmacology (12.3)*].

Conduct liver function tests (ALT, AST, and bilirubin) prior to initiation of treatment with OFEV, at regular intervals during the first three months of treatment, and periodically thereafter or as clinically indicated. Measure liver tests promptly in patients who report symptoms that may indicate liver injury, including fatigue, anorexia, right upper abdominal discomfort, dark urine or jaundice. Dosage modifications or interruption may be necessary for liver enzyme elevations [*see Dosage and Administration (2.1, 2.3)*].

5.3 Gastrointestinal Disorders

Diarrhea

In clinical trials, diarrhea was the most frequent gastrointestinal event reported. In most patients, the event was of mild to moderate intensity and occurred within the first 3 months of treatment. In IPF studies (Study 1, Study 2, and Study 3), diarrhea was reported in 62% versus 18% of patients treated with OFEV and placebo, respectively [see *Adverse Reactions (6.1)*]. Diarrhea led to permanent dose reduction in 11% of patients treated with OFEV compared to 0 placebo-treated patients. Diarrhea led to discontinuation of OFEV in 5% of the patients compared to less than 1% of placebo-treated patients. In the chronic fibrosing ILDs with a progressive phenotype study (Study 5), diarrhea was reported in 67% versus 24% of patients treated with OFEV and placebo, respectively [see *Adverse Reactions (6.1)*]. Diarrhea led to permanent dose reduction in 16% of patients treated with OFEV compared to less than 1% of placebo-treated patients. Diarrhea led to discontinuation of OFEV in 6% of the patients compared to less than 1% of placebo-treated patients. In the SSc-ILD study (Study 4), diarrhea was reported in 76% versus 32% of patients treated with OFEV and placebo, respectively [see *Adverse Reactions (6.1)*]. Diarrhea led to permanent dose reduction in 22% of patients treated with OFEV compared to 1% of placebo-treated patients. Diarrhea led to discontinuation of OFEV in 7% of the patients compared to 0.3% of placebo-treated patients.

Dosage modifications or treatment interruptions may be necessary in patients with adverse reactions of diarrhea. Treat diarrhea at first signs with adequate hydration and antidiarrheal medication (e.g., loperamide), and consider dose reduction or treatment interruption if diarrhea continues [see *Dosage and Administration (2.3)*]. OFEV treatment may be resumed at the full dosage (150 mg twice daily), or at the reduced dosage (100 mg twice daily), which subsequently may be increased to the full dosage. If severe diarrhea persists despite symptomatic treatment, discontinue treatment with OFEV.

Nausea and Vomiting

In IPF studies (Study 1, Study 2, and Study 3), nausea was reported in 24% versus 7% and vomiting was reported in 12% versus 3% of patients treated with OFEV and placebo, respectively. In the chronic fibrosing ILDs with a progressive phenotype study (Study 5), nausea was reported in 29% versus 9% and vomiting was reported in 18% versus 5% of patients treated with OFEV and placebo, respectively. In the SSc-ILD study (Study 4), nausea was reported in 32% versus 14% and vomiting was reported in 25% versus 10% of patients treated with OFEV and placebo, respectively [see *Adverse Reactions (6.1)*]. In most patients, these events were of mild to moderate intensity. In IPF studies (Study 1, Study 2, and Study 3), nausea led to discontinuation of OFEV in 2% of patients and vomiting led to discontinuation of OFEV in 1% of the patients. In the chronic fibrosing ILDs with a progressive phenotype study (Study 5), nausea led to discontinuation of OFEV in less than 1% of patients and vomiting led to discontinuation of OFEV in 1% of the patients. In the SSc-ILD study (Study 4), nausea led to discontinuation of OFEV in 2% of patients and vomiting led to discontinuation of OFEV in 1% of the patients.

For nausea or vomiting that persists despite appropriate supportive care including anti-emetic therapy, dose reduction or treatment interruption may be required [see *Dosage and Administration (2.3)*]. OFEV treatment may be resumed at the full dosage (150 mg twice daily), or at the reduced dosage (100 mg twice daily), which subsequently may be increased to the full dosage. If severe nausea or vomiting does not resolve, discontinue treatment with OFEV.

5.4 Embryo-Fetal Toxicity

Based on findings from animal studies and its mechanism of action, OFEV can cause fetal harm when administered to a pregnant woman. Nintedanib caused embryo-fetal deaths and structural abnormalities in rats and rabbits when administered during organogenesis at less than (rats) and approximately 5 times (rabbits) the maximum recommended human dose (MRHD) in adults. Advise pregnant women of the potential risk to a fetus. Advise females of reproductive potential to avoid becoming pregnant while receiving treatment with OFEV and to use highly effective contraception during treatment and at least 3 months after the last dose of OFEV. It is currently unknown whether nintedanib may reduce the effectiveness of hormonal contraceptives, therefore advise women using hormonal contraceptives to add a barrier method. Verify pregnancy status prior to treatment with OFEV and during treatment as appropriate [see *Use in Specific Populations (8.1, 8.3) and Clinical Pharmacology (12.1)*].

5.5 Arterial Thromboembolic Events

Arterial thromboembolic events have been reported in patients taking OFEV. In IPF studies (Study 1, Study 2, and Study 3), arterial thromboembolic events were reported in 2.5% of patients treated with OFEV and less than 1% of placebo-treated patients. Myocardial infarction was the most common adverse reaction under arterial thromboembolic events, occurring in 1.5% of OFEV-treated patients compared to less than 1% of placebo-treated patients. In the chronic fibrosing ILDs with a progressive phenotype study (Study 5), arterial thromboembolic events were reported in less than 1% of patients in both treatment arms. Myocardial infarction was observed in less than 1% of patients in both treatment arms. In the SSc-ILD study (Study 4), arterial thromboembolic events were reported in 0.7% of patients in both treatment arms. There were 0 cases of myocardial infarction in OFEV-treated patients compared to 0.7% of placebo-treated patients.

Use caution when treating patients at higher cardiovascular risk including known coronary artery disease. Consider treatment interruption in patients who develop signs or symptoms of acute myocardial ischemia.

5.6 Risk of Bleeding

Based on the mechanism of action (VEGFR inhibition), OFEV may increase the risk of bleeding. In IPF studies (Study 1, Study 2, and Study 3), bleeding events were reported in 10% of patients treated with OFEV and in 7% of patients treated with placebo. In the chronic fibrosing ILDs with a progressive phenotype study (Study 5), bleeding events were reported in 11% of patients treated with OFEV and in 13% of patients treated with placebo. In the SSc-ILD study (Study 4), bleeding events were reported in 11% of patients treated with OFEV and in 8% of patients treated with placebo. In clinical trials, epistaxis was the most frequent bleeding event reported.

In the postmarketing period non-serious and serious bleeding events, some of which were fatal, have been observed.

Use OFEV in patients with known risk of bleeding only if the anticipated benefit outweighs the potential risk.

5.7 Gastrointestinal Perforation

Based on the mechanism of action, OFEV may increase the risk of gastrointestinal perforation. In IPF studies (Study 1, Study 2, and Study 3), gastrointestinal perforation was reported in less than 1% of patients treated with OFEV, compared to 0 cases in the placebo-treated patients. In the chronic fibrosing ILDs with a progressive phenotype study (Study 5), gastrointestinal perforation was not reported in any patients in any treatment arm. In the SSc-ILD study (Study 4), no cases of gastrointestinal perforation were reported in patients treated with OFEV or in placebo-treated patients.

In the postmarketing period, cases of gastrointestinal perforations have been reported, some of which were fatal.

Use caution when treating patients who have had recent abdominal surgery, previous history of diverticular disease or receiving concomitant corticosteroids or NSAIDs. Discontinue therapy with OFEV in patients who develop gastrointestinal perforation. Only use OFEV in patients with known risk of gastrointestinal perforation if the anticipated benefit outweighs the potential risk.

6 ADVERSE REACTIONS

The following adverse reactions are discussed in greater detail in other sections of the labeling:

- Elevated Liver Enzymes and Drug-Induced Liver Injury [*see Warnings and Precautions (5.2)*]
- Gastrointestinal Disorders [*see Warnings and Precautions (5.3)*]
- Embryo-Fetal Toxicity [*see Warnings and Precautions (5.4)*]
- Arterial Thromboembolic Events [*see Warnings and Precautions (5.5)*]
- Risk of Bleeding [*see Warnings and Precautions (5.6)*]
- Gastrointestinal Perforation [*see Warnings and Precautions (5.7)*]

6.1 Clinical Trials Experience

Because clinical trials are conducted under widely varying conditions, adverse reaction rates observed in the clinical trials of a drug cannot be directly compared to rates in the clinical trials of another drug and may not reflect the rates observed in practice.

The safety of OFEV was evaluated in over 1000 IPF patients, 332 patients with chronic fibrosing ILDs with a progressive phenotype, and over 280 patients with SSc-ILD. Over 200 IPF patients were exposed to OFEV for more than 2 years in clinical trials.

Idiopathic Pulmonary Fibrosis

OFEV was studied in three randomized, double-blind, placebo-controlled, 52-week trials. In the phase 2 (Study 1) and phase 3 (Study 2 and Study 3) trials, 723 patients with IPF received OFEV 150 mg twice daily and 508 patients received placebo. The median duration of exposure was 10 months for patients treated with OFEV and 11 months for patients treated with placebo. Subjects ranged in age from 42 to 89 years (median age of 67 years). Most patients were male (79%) and Caucasian (60%).

The most frequent serious adverse reactions reported in patients treated with OFEV, more than placebo, were bronchitis (1.2% vs. 0.8%) and myocardial infarction (1.5% vs. 0.4%). The most common adverse events leading to death in patients treated with OFEV, more than placebo, were pneumonia (0.7% vs. 0.6%), lung neoplasm malignant (0.3% vs. 0%), and myocardial infarction (0.3% vs. 0.2%). In the predefined category of major adverse cardiovascular events (MACE) including MI, fatal events were reported in 0.6% of OFEV-treated patients and 1.8% of placebo-treated patients.

Adverse reactions leading to permanent dose reductions were reported in 16% of OFEV-treated patients and 1% of placebo-treated patients. The most frequent adverse reaction that led to permanent dose reduction in the patients treated with OFEV was diarrhea (11%).

Adverse reactions leading to discontinuation were reported in 21% of OFEV-treated patients and 15% of placebo-treated patients. The most frequent adverse reactions that led to discontinuation in OFEV-treated patients were diarrhea (5%), nausea (2%), and decreased appetite (2%).

The most common adverse reactions with an incidence of greater than or equal to 5% and more frequent in the OFEV than placebo treatment group are listed in Table 1.

Table 1 Adverse Reactions Occurring in $\geq 5\%$ of OFEV-treated Patients and More Commonly Than Placebo in Study 1, Study 2, and Study 3

Adverse Reaction	OFEV, 150 mg n=723	Placebo n=508
Gastrointestinal disorders		
Diarrhea	62%	18%
Nausea	24%	7%
Abdominal pain ^a	15%	6%
Vomiting	12%	3%
Hepatobiliary disorders		
Liver enzyme elevation ^b	14%	3%
Metabolism and nutrition disorders		
Decreased appetite	11%	5%
Nervous system disorders		
Headache	8%	5%
Investigations		
Weight decreased	10%	3%
Vascular disorders		
Hypertension ^c	5%	4%

^a Includes abdominal pain, abdominal pain upper, abdominal pain lower, gastrointestinal pain and abdominal tenderness.

^b Includes gamma-glutamyltransferase increased, hepatic enzyme increased, alanine aminotransferase increased, aspartate aminotransferase increased, hepatic function abnormal, liver function test abnormal, transaminase increased, blood alkaline phosphatase-increased, alanine aminotransferase abnormal, aspartate aminotransferase abnormal, and gamma-glutamyltransferase abnormal.

^c Includes hypertension, blood pressure increased, hypertensive crisis, and hypertensive cardiomyopathy.

In addition, hypothyroidism was reported in patients treated with OFEV, more than placebo (1.1% vs. 0.6%). Alopecia was also reported in more patients treated with OFEV than placebo (0.8% vs. 0.4%).

Combination with Pirfenidone

Concomitant treatment with nintedanib and pirfenidone was investigated in an exploratory open-label, randomized (1:1) trial of nintedanib 150 mg twice daily with add-on pirfenidone (titrated to 801 mg three times a day) compared to nintedanib 150 mg twice daily alone in 105 randomized patients for 12 weeks. The primary endpoint was the percentage of patients with gastrointestinal adverse events from baseline to Week 12. Gastrointestinal adverse events were in line with the established safety profile of each component and were experienced in 37 (70%) patients treated with pirfenidone added to nintedanib versus 27 (53%) patients treated with nintedanib alone.

Diarrhea, nausea, vomiting, and abdominal pain (includes upper abdominal pain, abdominal discomfort, and abdominal pain) were the most frequent adverse events reported in 20 (38%) versus 16 (31%), in 22 (42%) versus 6 (12%), in 15 (28%) versus 6 (12%), and in 15 (28%) versus 7 (14%) patients treated with pirfenidone added to nintedanib versus nintedanib alone, respectively. More subjects reported AST or ALT elevations (greater than or equal to 3x the upper limit of normal) when using pirfenidone in combination with nintedanib (n=3 (6%)) compared to nintedanib alone (n=0) [see *Warnings and Precautions (5.2, 5.3)*].

Chronic Fibrosing Interstitial Lung Diseases with a Progressive Phenotype

OFEV was studied in a phase 3, double-blind, placebo-controlled trial (Study 5) in which 663 patients with chronic fibrosing ILDs with a progressive phenotype were randomized to receive OFEV 150 mg twice daily (n=332) or placebo (n=331) for at least 52 weeks. At 52 weeks, the median duration of exposure was 12 months for patients in both treatment arms. Subjects ranged in age from 27 to 87 years (median age of 67 years). The majority of patients were Caucasian (74%) or Asian (25%). Most patients were male (54%).

The most frequent serious adverse event reported in patients treated with OFEV, more than placebo, was pneumonia (4% vs. 3%). Adverse events leading to death were reported in 3% of patients treated with OFEV and in 5% of patients treated with placebo. No pattern was identified in the adverse events leading to death.

Adverse reactions leading to permanent dose reductions were reported in 33% of OFEV-treated patients and 4% of placebo-treated patients. The most frequent adverse reaction that led to permanent dose reduction in the patients treated with OFEV was diarrhea (16%).

Adverse reactions leading to discontinuation were reported in 20% of OFEV-treated patients and 10% of placebo-treated patients. The most frequent adverse reaction that led to discontinuation in OFEV-treated patients was diarrhea (6%).

The safety profile in patients with chronic fibrosing ILDs with a progressive phenotype treated with OFEV was consistent with that observed in IPF patients. In addition, the following adverse events were reported in OFEV more than placebo in chronic progressive fibrosing ILD: nasopharyngitis (13% vs. 12%), upper respiratory tract infection (7% vs 6%), urinary tract infection (6% vs. 4%), fatigue (10% vs. 6%), and back pain (6% vs. 5%).

Systemic Sclerosis-Associated Interstitial Lung Disease

OFEV was studied in a phase 3, randomized, double-blind, placebo-controlled trial (Study 4) in which 576 patients with SSc-ILD received OFEV 150 mg twice daily (n=288) or placebo (n=288). Patients were to receive treatment for at least 52 weeks; individual patients were treated for up to 100 weeks. The median duration of exposure was 15 months for patients treated with OFEV and 16 months for patients treated with placebo. Subjects ranged in age from 20 to 79 years (median age of 55 years). Most patients were female (75%). Patients were mostly Caucasian (67%), Asian (25%), or Black (6%). At baseline, 49% of patients were on stable therapy with mycophenolate.

The most frequent serious adverse events reported in patients treated with OFEV, more than placebo, were interstitial lung disease (2.4% nintedanib vs. 1.7% placebo) and pneumonia (2.8% nintedanib vs. 0.3% placebo). Within 52 weeks, 5 patients treated with OFEV (1.7%) and 4 patients treated with placebo (1.4%) died. There was no pattern among adverse events leading to death in either treatment arm.

Adverse reactions leading to permanent dose reductions were reported in 34% of OFEV-treated patients and 4% of placebo-treated patients. The most frequent adverse reaction that led to permanent dose reduction in the patients treated with OFEV was diarrhea (22%).

Adverse reactions leading to discontinuation were reported in 16% of OFEV-treated patients and 9% of placebo-treated patients. The most frequent adverse reactions that led to discontinuation in OFEV-treated patients were diarrhea (7%), nausea (2%), vomiting (1%), abdominal pain (1%), and interstitial lung disease (1%).

The safety profile in patients treated with OFEV with or without mycophenolate at baseline was comparable.

The most common adverse reactions with an incidence of greater than or equal to 5% in OFEV-treated patients and more commonly than in placebo are listed in Table 2.

Table 2 Adverse Reactions Occurring in $\geq 5\%$ of OFEV-treated Patients and More Commonly Than Placebo in Study 4

Adverse Reaction	OFEV, 150 mg n=288	Placebo n=288
Diarrhea	76%	32%
Nausea	32%	14%
Vomiting	25%	10%
Skin ulcer	18%	17%
Abdominal pain ^a	18%	11%
Liver enzyme elevation ^b	13%	3%
Weight decreased	12%	4%
Fatigue	11%	7%
Decreased appetite	9%	4%
Headache	9%	8%
Pyrexia	6%	5%
Back pain	6%	4%
Dizziness	6%	4%
Hypertension ^c	5%	2%

^a Includes abdominal pain, abdominal pain upper, abdominal pain lower, and esophageal pain.

^b Includes alanine aminotransferase increased, gamma-glutamyltransferase increased, aspartate aminotransferase increased, hepatic enzyme increased, blood alkaline phosphatase increased, transaminase increased, and hepatic function abnormal.

^c Includes hypertension, blood pressure increased, and hypertensive crisis.

In addition, alopecia was reported in patients treated with OFEV, more than placebo (1.4% vs. 1.0%).

6.2 Postmarketing Experience

The following adverse reactions have been identified during postapproval use of OFEV. Because these reactions are reported voluntarily from a population of uncertain size, it is not always possible to reliably estimate their frequency or establish a causal relationship to drug exposure. The following adverse reactions have been identified during postapproval use of OFEV: drug-induced liver injury [see *Warnings and Precautions (5.2)*], non-serious and serious bleeding events, some of which were fatal [see *Warnings and Precautions (5.6)*], pancreatitis, thrombocytopenia, rash, pruritus.

7 DRUG INTERACTIONS

7.1 P-glycoprotein (P-gp) and CYP3A4 Inhibitors and Inducers

Nintedanib is a substrate of P-gp and, to a minor extent, CYP3A4 [see *Clinical Pharmacology (12.3)*]. Coadministration with oral doses of a P-gp and CYP3A4 inhibitor, ketoconazole, increased exposure to nintedanib by 60%. Concomitant use of P-gp and CYP3A4 inhibitors (e.g., erythromycin) with OFEV may increase exposure to nintedanib [see *Clinical Pharmacology (12.3)*]. In such cases, patients should be monitored closely for tolerability of OFEV. Management of adverse reactions may require interruption, dose reduction, or discontinuation of therapy with OFEV [see *Dosage and Administration (2.3)*].

Coadministration with oral doses of a P-gp and CYP3A4 inducer, rifampicin, decreased exposure to nintedanib by 50%. Concomitant use of P-gp and CYP3A4 inducers (e.g., carbamazepine, phenytoin, and St. John's wort) with OFEV should be avoided as these drugs may decrease exposure to nintedanib [see *Clinical Pharmacology (12.3)*].

7.2 Anticoagulants

Nintedanib is a VEGFR inhibitor and may increase the risk of bleeding. Monitor patients on full anticoagulation therapy closely for bleeding and adjust anticoagulation treatment as necessary [see *Warnings and Precautions (5.6)*].

7.3 Pirfenidone

In a multiple-dose study conducted to assess the pharmacokinetic effects of concomitant treatment with nintedanib and pirfenidone, the coadministration of nintedanib with pirfenidone did not alter the exposure of either agent [see *Clinical Pharmacology (12.3)*]. Therefore, no dose adjustment is necessary during concomitant administration of nintedanib with pirfenidone.

7.4 Bosentan

Coadministration of nintedanib with bosentan did not alter the pharmacokinetics of nintedanib [see *Clinical Pharmacology (12.3)*].

8 USE IN SPECIFIC POPULATIONS

8.1 Pregnancy

Risk Summary

Based on findings from animal studies and its mechanism of action [see *Clinical Pharmacology (12.1)*], OFEV can cause fetal harm when administered to a pregnant woman. There are no data on the use of OFEV during pregnancy. In animal studies of pregnant rats and rabbits treated during organogenesis, nintedanib caused embryo-fetal deaths and structural abnormalities at less than (rats) and approximately 5 times (rabbits) the maximum recommended human dose [see *Data*]. Advise pregnant women of the potential risk to a fetus.

The estimated background risk of major birth defects and miscarriage for the indicated population is unknown. In the U.S. general population, the estimated background risk of major birth defects is 2% to 4% and miscarriage in clinically recognized pregnancies is 15% to 20%.

Data

Animal Data

In animal reproduction toxicity studies, nintedanib caused embryo-fetal deaths and structural abnormalities in rats and rabbits at less than and approximately 5 times the maximum recommended human dose (MRHD) in adults (on a plasma AUC basis at maternal oral doses of 2.5 and 15 mg/kg/day in rats and rabbits, respectively). Malformations included abnormalities in the vasculature, urogenital, and skeletal systems. Vasculature anomalies included missing or additional major blood vessels. Skeletal anomalies included abnormalities in the thoracic, lumbar, and caudal vertebrae (e.g., hemivertebra, missing, or asymmetrically ossified), ribs (bifid or fused), and sternbrae (fused, split, or unilaterally ossified). In some fetuses, organs in the urogenital system were missing. In rabbits, a significant change in sex ratio was observed in fetuses (female:male ratio of approximately 71%:29%) at approximately 15 times the MRHD in adults (on an AUC basis at a maternal oral dose of 60 mg/kg/day). Nintedanib decreased post-natal viability of rat pups during the first 4 post-natal days when dams were exposed to less than the MRHD (on an AUC basis at a maternal oral dose of 10 mg/kg/day).

8.2 Lactation

Risk Summary

There is no information on the presence of nintedanib in human milk, the effects on the breast-fed infant or the effects on milk production. Nintedanib and/or its metabolites are present in the milk of lactating rats [see *Data*]. Because of the potential for serious adverse reactions in nursing infants from OFEV, advise women that breastfeeding is not recommended during treatment with OFEV.

Data

Milk and plasma of lactating rats have similar concentrations of nintedanib and its metabolites.

8.3 Females and Males of Reproductive Potential

Based on findings from animal studies and its mechanism of action, OFEV can cause fetal harm when administered to a pregnant woman and may reduce fertility in females of reproductive potential [see *Use in Specific Populations (8.1), Clinical Pharmacology (12.1), and Nonclinical Toxicology (13.1)*]. Counsel patients on pregnancy prevention and planning.

Pregnancy Testing

Verify the pregnancy status of females of reproductive potential prior to treatment with OFEV and during treatment as appropriate [see *Dosage and Administration (2.1), Warnings and Precautions (5.4), and Use in Specific Populations (8.1)*].

Contraception

OFEV can cause fetal harm when administered to a pregnant woman. Advise females of reproductive potential to avoid becoming pregnant while receiving treatment with OFEV. Advise females of reproductive potential to use highly effective contraception during treatment, and for at least 3 months after taking the last dose of OFEV. It is currently unknown whether nintedanib may reduce the effectiveness of hormonal contraceptives, therefore advise women using hormonal contraceptives to add a barrier method.

Infertility

Based on animal data, OFEV may reduce fertility in females of reproductive potential [see *Nonclinical Toxicology (13.1)*].

8.4 Pediatric Use

Safety and effectiveness in pediatric patients have not been established.

8.5 Geriatric Use

Of the total number of subjects in phase 2 and 3 clinical studies of OFEV in IPF (Study 1, Study 2, and Study 3), 61% were 65 and over, while 16% were 75 and over. In the chronic fibrosing ILDs with a progressive phenotype clinical study (Study 5), 61% were 65 and over, while 19% were 75 and older. In SSc-ILD (Study 4), 21.4% were 65 and over, while 1.9% were 75 and older. In phase 3 studies, no overall differences in effectiveness were observed between subjects who were 65 and over and younger subjects; no overall differences in safety were observed between subjects who were 65 and over or 75 and over and younger subjects, but greater sensitivity of some older individuals cannot be ruled out.

8.6 Hepatic Impairment

Nintedanib is predominantly eliminated via biliary/fecal excretion (greater than 90%). In a PK study performed in patients with hepatic impairment (Child Pugh A, Child Pugh B), exposure to nintedanib was increased [see *Clinical Pharmacology (12.3)*]. In patients with mild hepatic impairment (Child Pugh A), the recommended dosage of OFEV is 100 mg twice daily [see *Dosage and Administration (2.2)*]. Monitor for adverse reactions and consider treatment interruption, or discontinuation for management of adverse reactions in these patients [see *Dosage and Administration (2.3)*]. Treatment of patients with moderate (Child Pugh B) and severe (Child Pugh C) hepatic impairment with OFEV is not recommended [see *Warnings and Precautions (5.1)*].

8.7 Renal Impairment

Based on a single-dose study, less than 1% of the total dose of nintedanib is excreted via the kidney [see *Clinical Pharmacology (12.3)*]. Adjustment of the starting dose in patients with mild to moderate renal impairment is not required. The safety, efficacy, and pharmacokinetics of nintedanib have not been studied in patients with severe renal impairment (less than 30 mL/min CrCl) and end-stage renal disease.

8.8 Smokers

Smoking was associated with decreased exposure to OFEV [see *Clinical Pharmacology (12.3)*], which may alter the efficacy profile of OFEV. Encourage patients to stop smoking prior to treatment with OFEV and to avoid smoking when using OFEV.

10 OVERDOSAGE

In IPF trials, one patient was inadvertently exposed to a dose of 600 mg daily for a total of 21 days. A non-serious adverse event (nasopharyngitis) occurred and resolved during the period of incorrect dosing, with no onset of other reported events. Overdose was also reported in two patients in oncology studies who were exposed to a maximum of 600 mg twice daily for up to 8 days. Adverse events reported were consistent with the existing safety profile of OFEV. Both patients recovered. In case of overdose, interrupt treatment and initiate general supportive measures as appropriate.

11 DESCRIPTION

OFEV capsules contain nintedanib, a kinase inhibitor [see *Mechanism of Action (12.1)*]. Nintedanib is presented as the ethanesulfonate salt (esylate), with the chemical name 1*H*-Indole-6-carboxylic acid, 2,3-dihydro-3-[[[4-[methyl[(4-methyl-1-piperazinyl)acetyl]amino]phenyl]amino]phenylmethylene]-2-oxo-,methyl ester, (3*Z*)-, ethanesulfonate (1:1).

Its structural formula is:

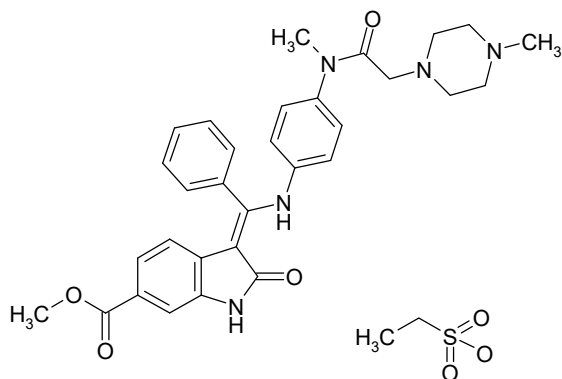

Nintedanib esylate is a bright yellow powder with an empirical formula of $C_{31}H_{33}N_5O_4 \cdot C_2H_6O_3S$ and a molecular weight of 649.76 g/mol.

OFEV capsules for oral administration are available in 2 dose strengths containing 100 mg or 150 mg of nintedanib (equivalent to 120.40 mg or 180.60 mg nintedanib ethanesulfonate, respectively). The inactive ingredients of OFEV are the following: Fill Material: triglycerides, hard fat, lecithin. Capsule Shell: gelatin, glycerol, titanium dioxide, red ferric oxide, yellow ferric oxide, black ink.

12 CLINICAL PHARMACOLOGY

12.1 Mechanism of Action

Nintedanib is a small molecule that inhibits multiple receptor tyrosine kinases (RTKs) and non-receptor tyrosine kinases (nRTKs). Nintedanib inhibits the following RTKs: platelet-derived growth factor receptor (PDGFR) α and β , fibroblast growth factor receptor (FGFR) 1-3, vascular endothelial growth factor receptor (VEGFR) 1-3, colony stimulating factor 1 receptor (CSF1R), and Fms-like tyrosine kinase-3 (FLT-3). These kinases except for FLT-3 have been implicated in pathogenesis of interstitial lung diseases (ILD). Nintedanib binds competitively to the adenosine triphosphate (ATP) binding pocket of these kinases and blocks the intracellular signaling

cascades, which have been demonstrated to be involved in the pathogenesis of fibrotic tissue remodeling in ILD. Nintedanib also inhibits the following nRTKs: Lck, Lyn and Src kinases. The contribution of FLT-3 and nRTK inhibition to nintedanib efficacy in ILD is unknown.

12.2 Pharmacodynamics

Cardiac Electrophysiology

In a study in renal cell cancer patients, QT/QTc measurements were recorded and showed that a single oral dose of 200 mg nintedanib as well as multiple oral doses of 200 mg nintedanib administered twice daily for 15 days did not prolong the QTcF interval.

12.3 Pharmacokinetics

The PK properties of nintedanib were similar in healthy volunteers, patients with IPF, patients with chronic fibrosing ILDs with a progressive phenotype, patients with SSc-ILD, and cancer patients. The PK of nintedanib is linear. Dose proportionality was shown by an increase of nintedanib exposure with increasing doses (dose range 50 to 450 mg once daily and 150 to 300 mg twice daily). Accumulation upon multiple administrations in patients with IPF was 1.76-fold for AUC. Steady-state plasma concentrations were achieved within one week of dosing. Nintedanib trough concentrations remained stable for more than one year. The inter-individual variability in the PK of nintedanib was moderate to high (coefficient of variation of standard PK parameters in the range of 30% to 70%), intra-individual variability low to moderate (coefficients of variation below 40%).

Absorption

Nintedanib reached maximum plasma concentrations approximately 2 to 4 hours after oral administration as a soft gelatin capsule under fed conditions. The absolute bioavailability of a 100 mg dose was 4.7% (90% CI: 3.62 to 6.08) in healthy volunteers. Absorption and bioavailability are decreased by transporter effects and substantial first-pass metabolism.

After food intake, nintedanib exposure increased by approximately 20% compared to administration under fasted conditions (90% CI: 95.3% to 152.5%) and absorption was delayed (median t_{max} fasted: 2.00 hours; fed: 3.98 hours), irrespective of the food type.

Distribution

Nintedanib follows bi-phasic disposition kinetics. After intravenous infusion, a high volume of distribution which was larger than total body volume (V_{ss} : 1050 L) was observed.

The *in vitro* protein binding of nintedanib in human plasma was high, with a bound fraction of 97.8%. Serum albumin is considered to be the major binding protein. Nintedanib is preferentially distributed in plasma with a blood to plasma ratio of 0.87.

Elimination

The effective half-life of nintedanib in patients with IPF was 9.5 hours (gCV 31.9%). Total plasma clearance after intravenous infusion was high (CL: 1390 mL/min; gCV 28.8%). Urinary excretion of unchanged drug within 48 hours was about 0.05% of the dose after oral and about 1.4% of the dose after intravenous administration; the renal clearance was 20 mL/min.

Metabolism

The prevalent metabolic reaction for nintedanib is hydrolytic cleavage by esterases resulting in the free acid moiety BIBF 1202. BIBF 1202 is subsequently glucuronidated by UGT enzymes, namely UGT 1A1, UGT 1A7, UGT 1A8, and UGT 1A10 to BIBF 1202 glucuronide. Only a minor extent of the biotransformation of nintedanib consisted of CYP pathways, with CYP3A4 being the predominant enzyme involved. The major CYP-dependent metabolite could not be detected in plasma in the human absorption, distribution, metabolism,

and elimination study. *In vitro*, CYP-dependent metabolism accounted for about 5% compared to about 25% ester cleavage.

Excretion

The major route of elimination of drug-related radioactivity after oral administration of [¹⁴C] nintedanib was via fecal/biliary excretion (93.4% of dose), and the majority of OFEV was excreted as BIBF 1202. The contribution of renal excretion to the total clearance was low (0.65% of dose). The overall recovery was considered complete (above 90%) within 4 days after dosing.

Specific Populations

Age, Body Weight, and Sex

Based on population PK analysis, age and body weight were correlated with nintedanib exposure. However, the effects on exposure are not sufficient to warrant a dose adjustment. There was no influence of sex on the exposure of nintedanib.

Renal Impairment

Based on a population PK analysis of data from 933 patients with IPF, exposure to nintedanib was not influenced by mild (CrCl: 60 to 90 mL/min; n=399) or moderate (CrCl: 30 to 60 mL/min; n=116) renal impairment. Data in severe renal impairment (CrCl below 30 mL/min) was limited.

Hepatic Impairment

A dedicated single-dose phase I pharmacokinetics study of OFEV compared 8 subjects with mild hepatic impairment (Child Pugh A) and 8 subjects with moderate hepatic impairment (Child Pugh B) to 17 subjects with normal hepatic function. In subjects with mild hepatic impairment, the mean exposure to nintedanib was 2.4-fold higher based on C_{max} (90% CI: 1.6 to 3.6) and 2.2-fold higher based on AUC_{0-inf} (90% CI: 1.4 to 3.5). In subjects with moderate hepatic impairment, exposure was 6.9-fold higher based on C_{max} (90% CI: 4.4 to 11.0) and 7.6-fold higher based on AUC_{0-inf} (90% CI: 5.1 to 11.3). Subjects with severe hepatic impairment (Child Pugh C) have not been studied.

Smokers

In the population PK analysis, the exposure of nintedanib was 21% lower in current smokers compared to ex- and never-smokers. The effect is not sufficient to warrant a dose adjustment.

Drug Interaction Studies

Potential for Nintedanib to Affect Other Drugs

Effect of nintedanib coadministration on pirfenidone AUC and C_{max} was evaluated in a multiple-dose study. Nintedanib did not have an effect on the exposure of pirfenidone.

In *in vitro* studies, nintedanib was shown not to be an inhibitor of OATP-1B1, OATP-1B3, OATP-2B1, OCT-2, or MRP-2. *In vitro* studies also showed that nintedanib has weak inhibitory potential on OCT-1, BCRP, and P-gp; these findings are considered to be of low clinical relevance. Nintedanib and its metabolites, BIBF 1202 and BIBF 1202 glucuronide, did not inhibit or induce CYP enzymes *in vitro*.

Potential for Other Drugs to Affect Nintedanib

Nintedanib is a substrate of P-gp and, to a minor extent, CYP3A4. Coadministration with the P-gp and CYP3A4 inhibitor, ketoconazole, increased exposure to nintedanib 1.61-fold based on AUC and 1.83-fold based on C_{max} in a dedicated drug-drug interaction study. In a drug-drug interaction study with the P-gp and CYP3A4 inducer, rifampicin, exposure to nintedanib decreased to 50.3% based on AUC and to 60.3% based on C_{max} upon coadministration with rifampicin compared to administration of nintedanib alone.

Effect of pirfenidone coadministration on nintedanib AUC and C_{max} was evaluated in a multiple-dose drug-drug interaction study. Pirfenidone did not have an effect on the exposure of nintedanib. Concomitant treatment with nintedanib and pirfenidone was also investigated in a separate trial, which was an exploratory open-label, randomized (1:1) trial of nintedanib 150 mg twice daily with add-on pirfenidone (titrated to 801 mg three times a day) compared to nintedanib 150 mg twice daily alone in 105 randomized patients for 12 weeks. Similar nintedanib trough plasma concentrations were observed when comparing patients receiving nintedanib alone with patients receiving nintedanib with add-on pirfenidone.

Healthy volunteers received a single dose of 150 mg nintedanib before and after multiple dosing of 125 mg bosentan twice daily at steady state. Coadministration of nintedanib with bosentan did not alter the pharmacokinetics of nintedanib.

Nintedanib displays a pH-dependent solubility profile with increased solubility at acidic pH less than 3. However, in the clinical trials, coadministration with proton pump inhibitors or histamine H₂ antagonists did not influence the exposure (trough concentrations) of nintedanib.

In *in vitro* studies, nintedanib was shown not to be a substrate of OATP-1B1, OATP-1B3, OATP-2B1, OCT-2, MRP-2, or BCRP. *In vitro* studies also showed that nintedanib was a substrate of OCT-1; these findings are considered to be of low clinical relevance.

13 NONCLINICAL TOXICOLOGY

13.1 Carcinogenesis, Mutagenesis, Impairment of Fertility

Two-year oral carcinogenicity studies of nintedanib in rats and mice have not revealed any evidence of carcinogenic potential. Nintedanib was dosed up to 10 and 30 mg/kg/day in rats and mice, respectively. These doses were less than and approximately 4 times the MRHD on a plasma drug AUC basis.

Nintedanib was negative for genotoxicity in the *in vitro* bacterial reverse mutation assay, the mouse lymphoma cell forward mutation assay, and the *in vivo* rat micronucleus assay.

In rats, nintedanib reduced female fertility at exposure levels approximately 3 times the MRHD (on an AUC basis at an oral dose of 100 mg/kg/day). Effects included increases in resorption and post-implantation loss, and a decrease in gestation index. Changes in the number and size of corpora lutea in the ovaries were observed in chronic toxicity studies in rats and mice. An increase in the number of females with resorptions only was observed at exposures approximately equal to the MRHD (on an AUC basis at an oral dose of 20 mg/kg/day). Nintedanib had no effects on male fertility in rats at exposure levels approximately 3 times the MRHD (on an AUC basis at an oral dose of 100 mg/kg/day).

14 CLINICAL STUDIES

14.1 Idiopathic Pulmonary Fibrosis

The clinical efficacy of OFEV has been studied in 1231 patients with IPF in one phase 2 (Study 1 [NCT00514683]) and two phase 3 studies (Study 2 [NCT01335464] and Study 3 [NCT01335477]). These were randomized, double-blind, placebo-controlled studies comparing treatment with OFEV 150 mg twice daily to placebo for 52 weeks.

Study 2 and Study 3 were identical in design. Study 1 was very similar in design. Patients were randomized in a 3:2 ratio (1:1 for Study 1) to either OFEV 150 mg or placebo twice daily for 52 weeks. Study 1 also included other treatment arms (50 mg daily, 50 mg twice daily, and 100 mg twice daily) that are not further discussed. The primary endpoint was the annual rate of decline in Forced Vital Capacity (FVC). Time to first acute IPF

exacerbation was a key secondary endpoint in Study 2 and Study 3 and a secondary endpoint in Study 1. Change from baseline in FVC percent predicted and survival were additional secondary endpoints in all studies.

Patients were required to have a diagnosis of IPF (ATS/ERS/JRS/ALAT criteria) for less than 5 years. Diagnoses were centrally adjudicated based on radiologic and, if applicable, histopathologic confirmation. Patients were required to be greater than or equal to 40 years of age with an FVC greater than or equal to 50% of predicted and a carbon monoxide diffusing capacity (DLCO, corrected for hemoglobin) 30% to 79% of predicted. Patients with relevant airways obstruction (i.e., pre-bronchodilator FEV₁/FVC less than 0.7) or, in the opinion of the investigator, likely to receive a lung transplant during the studies were excluded (being listed for lung transplant was acceptable for inclusion). Patients with greater than 1.5 times ULN of ALT, AST, or bilirubin, patients with a known risk or predisposition to bleeding, patients receiving a full dose of anticoagulation treatment, and patients with a recent history of myocardial infarction or stroke were excluded from the studies. Patients were also excluded if they received other investigational therapy, azathioprine, cyclophosphamide, or cyclosporine A within 8 weeks of entry into this trial, or n-acetyl cysteine and prednisone (greater than 15 mg/day or equivalent) within 2 weeks. The majority of patients were Caucasian (60%) or Asian (30%) and male (79%). Patients had a mean age of 67 years and a mean FVC percent predicted of 80%.

Annual Rate of Decline in FVC

A statistically significant reduction in the annual rate of decline of FVC (in mL) was demonstrated in patients receiving OFEV compared to patients receiving placebo based on the random coefficient regression model, adjusted for gender, height, and age. The treatment effect on FVC was consistent in all 3 studies. See Table 3 for individual study results.

Table 3 Annual Rate of Decline in FVC (mL) in Study 1, Study 2, and Study 3^a

	Study 1		Study 2		Study 3	
	OFEV 150 mg twice daily	Placebo	OFEV 150 mg twice daily	Placebo	OFEV 150 mg twice daily	Placebo
Number of analyzed patients	84	83	309	204	329	219
Rate ^a of decline over 52 weeks	-60	-191	-115	-240	-114	-207
Comparison vs placebo Difference ^b	131		125		94	
95% CI	(27, 235)		(78, 173)		(45, 143)	

^aRandomized set in Study 1; treated set in Study 2 and Study 3

^bEstimated based on a random coefficient regression model

Figure 1 displays the change from baseline over time in both treatment groups for Study 2. When the mean observed FVC change from baseline was plotted over time, the curves diverged at all timepoints through Week 52. Similar plots were seen for Study 1 and Study 3.

Figure 1 Mean (SEM) Observed FVC Change from Baseline (mL) Over Time in Study 2

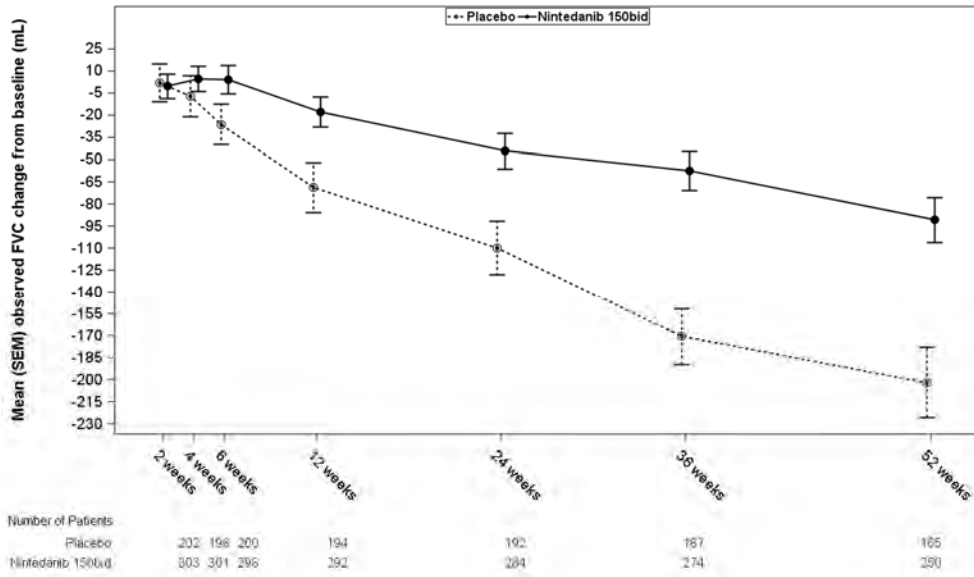

bid = twice daily

Change from Baseline in Percent Predicted Forced Vital Capacity

Figure 2 presents the cumulative distribution for all cut-offs for the change from baseline in FVC percent predicted at Week 52 for Study 2. For all categorical declines in lung function, the proportion of patients declining was lower on OFEV than on placebo. Study 3 showed similar results.

Figure 2 Cumulative Distribution of Patients by Change in Percent Predicted FVC from Baseline to Week 52 (Study 2).* The vertical lines indicate $\geq 0\%$ decline or $\geq 10\%$ decline.

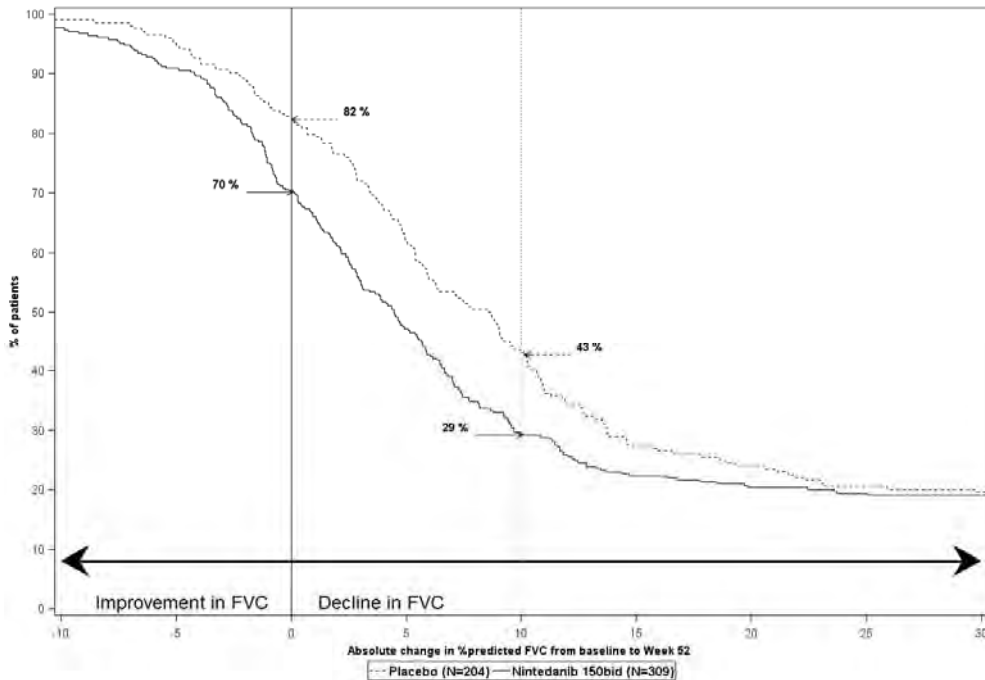

*Missing data for change from baseline at Week 52 in percent predicted FVC (due to death, lost to follow-up or censoring before 52 weeks) was imputed using the worst decline from baseline at Week 52 observed among all patients with available data, regardless of treatment.

bid = twice daily

Time to First Acute IPF Exacerbation

Acute IPF exacerbation was defined as unexplained worsening or development of dyspnea within 30 days, new diffuse pulmonary infiltrates on chest x-ray, and/or new high-resolution CT parenchymal abnormalities with no pneumothorax or pleural effusion, and exclusion of alternative causes. Acute IPF exacerbation was adjudicated in Study 2 and Study 3. In Study 1 (investigator-reported) and Study 3 (adjudicated), the risk of first acute IPF exacerbation over 52 weeks was significantly reduced in patients receiving OFEV compared to placebo (hazard ratio [HR]: 0.16, 95% CI: 0.04, 0.71) and (HR: 0.20, 95% CI: 0.07, 0.56), respectively. In Study 2 (adjudicated), there was no difference between the treatment groups (HR: 0.55, 95% CI: 0.20, 1.54).

Survival

Survival was evaluated for OFEV compared to placebo in Study 2 and Study 3 as an exploratory analysis to support the primary endpoint (FVC). All-cause mortality was assessed over the study duration and available follow-up period, irrespective of cause of death and whether patients continued treatment. All-cause mortality did not show a statistically significant difference (See Figure 3).

Figure 3 Kaplan-Meier Estimates of All-Cause Mortality at Vital Status – End of Study: Study 2 and Study 3

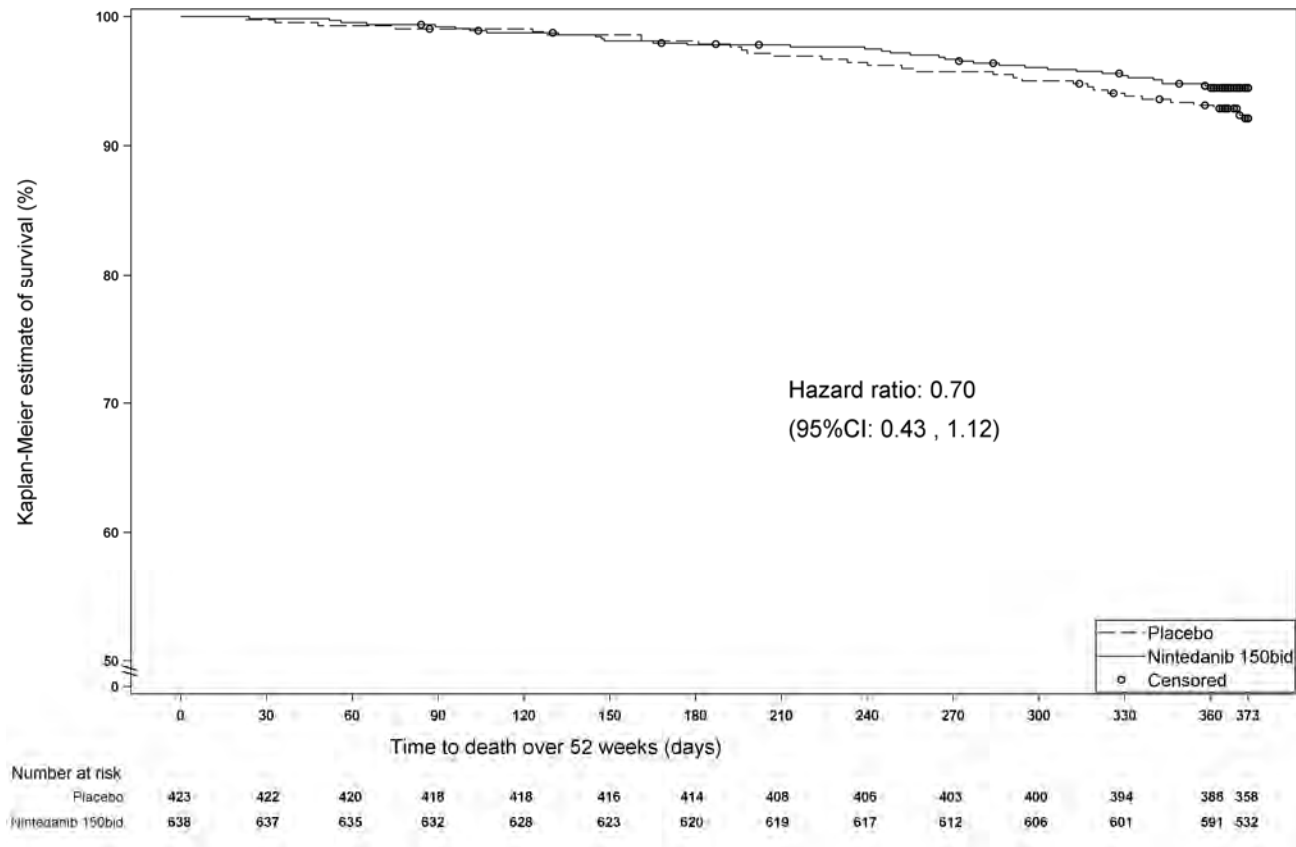

bid = twice daily

14.2 Chronic Fibrosing Interstitial Lung Diseases with a Progressive Phenotype

The clinical efficacy of OFEV has been studied in patients with chronic fibrosing ILDs with a progressive phenotype in a randomized, double-blind, placebo-controlled phase 3 trial (Study 5 [NCT02999178]). A total of 663 patients were randomized in a 1:1 ratio to receive either OFEV 150 mg twice daily or matching placebo for at least 52 weeks. Randomization was stratified based on high resolution computed tomography (HRCT) fibrotic pattern as assessed by central readers: 412 patients with UIP-like HRCT pattern and 251 patients with other HRCT fibrotic patterns were randomized. There were 2 co-primary populations defined for the analyses in this trial: all patients (the overall population) and patients with HRCT with UIP-like HRCT fibrotic pattern.

The primary endpoint was the annual rate of decline in FVC (in mL) over 52 weeks. Other endpoints included time to first acute ILD exacerbation and time to death.

Patients with a clinical diagnosis of a chronic fibrosing ILD were selected if they had relevant fibrosis (greater than 10% fibrotic features) on HRCT and presented with clinical signs of progression (defined as FVC decline $\geq 10\%$, FVC decline $\geq 5\%$ and $<10\%$ with worsening symptoms or imaging, or worsening symptoms and worsening imaging all in the 24 months prior to screening). Patients were required to have an FVC greater than or equal to 45% of predicted and a DLCO 30% to less than 80% of predicted. Patients were required to have progressed despite management deemed appropriate in clinical practice by investigators for the patient's relevant ILD.

Patients with IPF, relevant airways obstruction (i.e., pre-bronchodilator FEV1/FVC less than 0.7), or significant pulmonary hypertension were excluded from the trial. Patients with greater than 1.5 times ULN of ALT, AST, or bilirubin, patients with a known risk or predisposition to bleeding, patients receiving a full dose of

anticoagulation treatment, and patients with a recent history of myocardial infarction or stroke were excluded. Patients were also excluded if they received other investigational therapy, previous treatment with nintedanib or pirfenidone, azathioprine, cyclosporine, mycophenolate mofetil, tacrolimus, oral corticosteroids greater than 20 mg/day, or the combination of oral corticosteroids + azathioprine + n-acetylcysteine within 4 weeks of randomization, cyclophosphamide within 8 weeks prior to randomization, or rituximab within 6 months.

The majority of patients were Caucasian (74%) or Asian (25%). Patients were mostly male (54%) and had a mean age of 66 years and a mean FVC percent predicted of 69%, and 49% were never-smokers. The underlying clinical ILD diagnoses in groups represented in the trial were hypersensitivity pneumonitis (26%), autoimmune ILDs (26%), idiopathic nonspecific interstitial pneumonia (19%), unclassifiable idiopathic interstitial pneumonia (17%), and other ILDs (12%).

Annual Rate of Decline in FVC

There was a statistically significant reduction in the annual rate of decline in FVC (in mL) over 52 weeks in patients receiving OFEV compared to patients receiving placebo. The annual rate of decline in FVC (in mL) over 52 weeks was significantly reduced by 107 mL in patients receiving OFEV compared to patients receiving placebo. Results in the subpopulations of patients with HRCT with UIP-like fibrotic pattern and patients with other fibrotic patterns (Other HRCT) are included with the overall population in Table 4.

Table 4 Annual Rate of Decline in FVC (mL) in Study 5

	Overall		UIP-like Subpopulation		Other HRCT Subpopulation	
	OFEV	Placebo	OFEV	Placebo	OFEV	Placebo
Number of analyzed patients	331	331	206	206	125	125
Adjusted annual rate of decline over 52 weeks	-81	-188	-83	-211	-79	-154
Comparison vs placebo difference ^a	107		128		75*	
95% CI	(65, 148)		(71, 186)		(16, 135)*	

*Comparison based on the Other HRCT subpopulation was not included in the multiple testing procedure. Values shown here are for descriptive purposes.

^aBased on a random coefficient regression model with fixed categorical effects of treatment, HRCT pattern, fixed continuous effects of time, baseline FVC (mL), and including treatment by time and baseline by time interactions

A post-hoc exploratory analysis by ILD diagnosis was performed and is shown in Figure 4. Treatment response across ILD diagnoses was consistent for FVC.

Figure 4 Annual Rate of Decline in FVC (mL) over 52 Weeks based on Underlying ILD Diagnosis in Study 5*

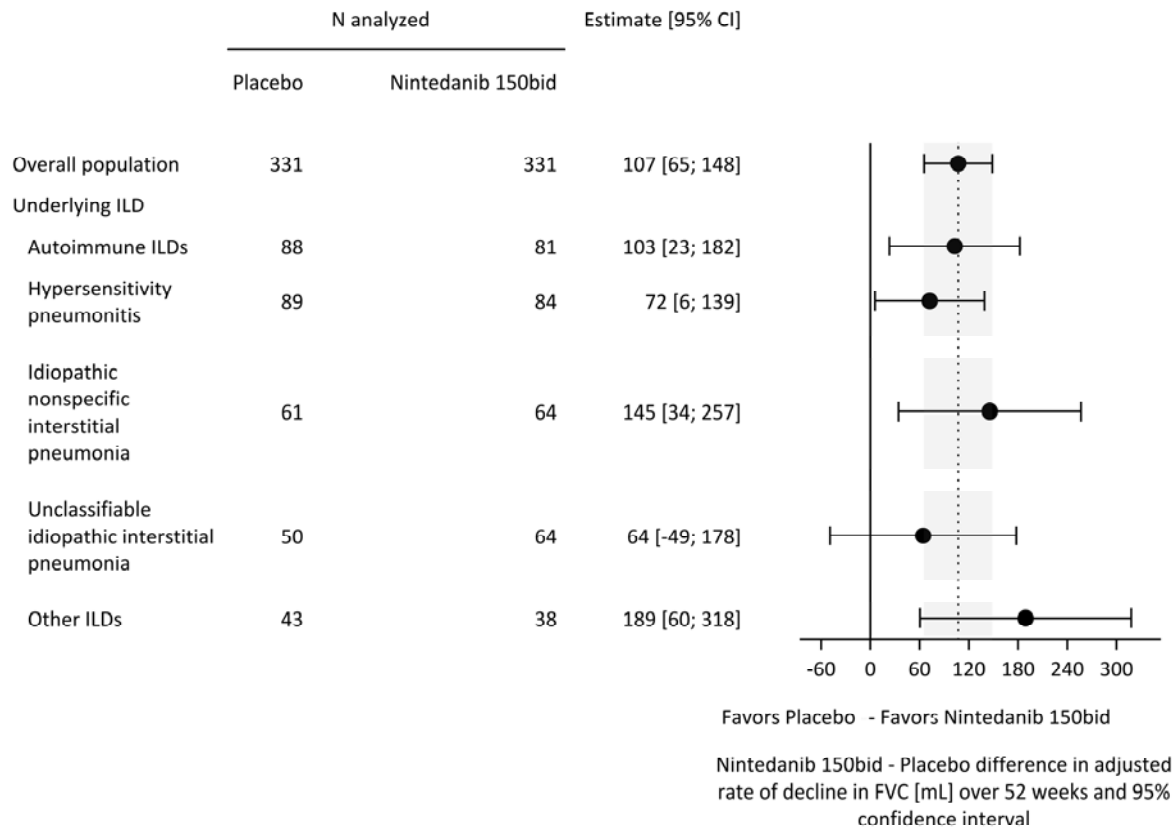

ILD = interstitial lung disease; Autoimmune ILDs: includes rheumatoid arthritis-associated ILD, mixed connective tissue disease, systemic sclerosis-associated ILD, and other terms; Other ILDs: includes fibrosing ILDs not categorized under autoimmune ILDs, hypersensitivity pneumonitis, idiopathic nonspecific interstitial pneumonia, or unclassifiable idiopathic interstitial pneumonia. The three most common ILDs in this category are exposure-related ILD, sarcoidosis, and pleuro-parenchymal fibroelastosis.

*These results are from a post-hoc exploratory analysis. Values shown here are for descriptive purposes.

Figure 5 shows the change in FVC from baseline over time in the treatment groups. When the mean observed FVC change from baseline was plotted over time, the curves diverged at all timepoints through Week 52.

Figure 5 Mean (SEM) Observed FVC Change from Baseline (mL) Over 52 Weeks in Study 5

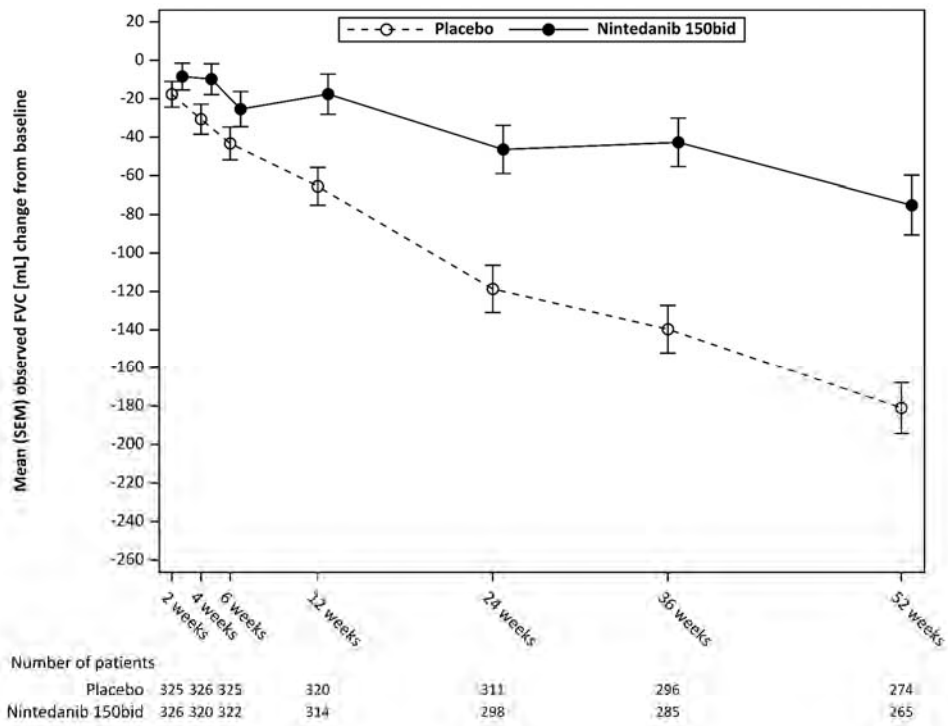

bid = twice daily

Percent Change from Baseline in Forced Vital Capacity

Figure 6 presents the percent change from baseline in FVC in mL at Week 52 for Study 5. For the majority of patients, the decline in lung function was less on OFEV than on placebo.

Figure 6 Histogram of the Percent Change in FVC (mL) from Baseline to Week 52 According to Treatment and Percent Increments or Decrements of 5 (Study 5)^a

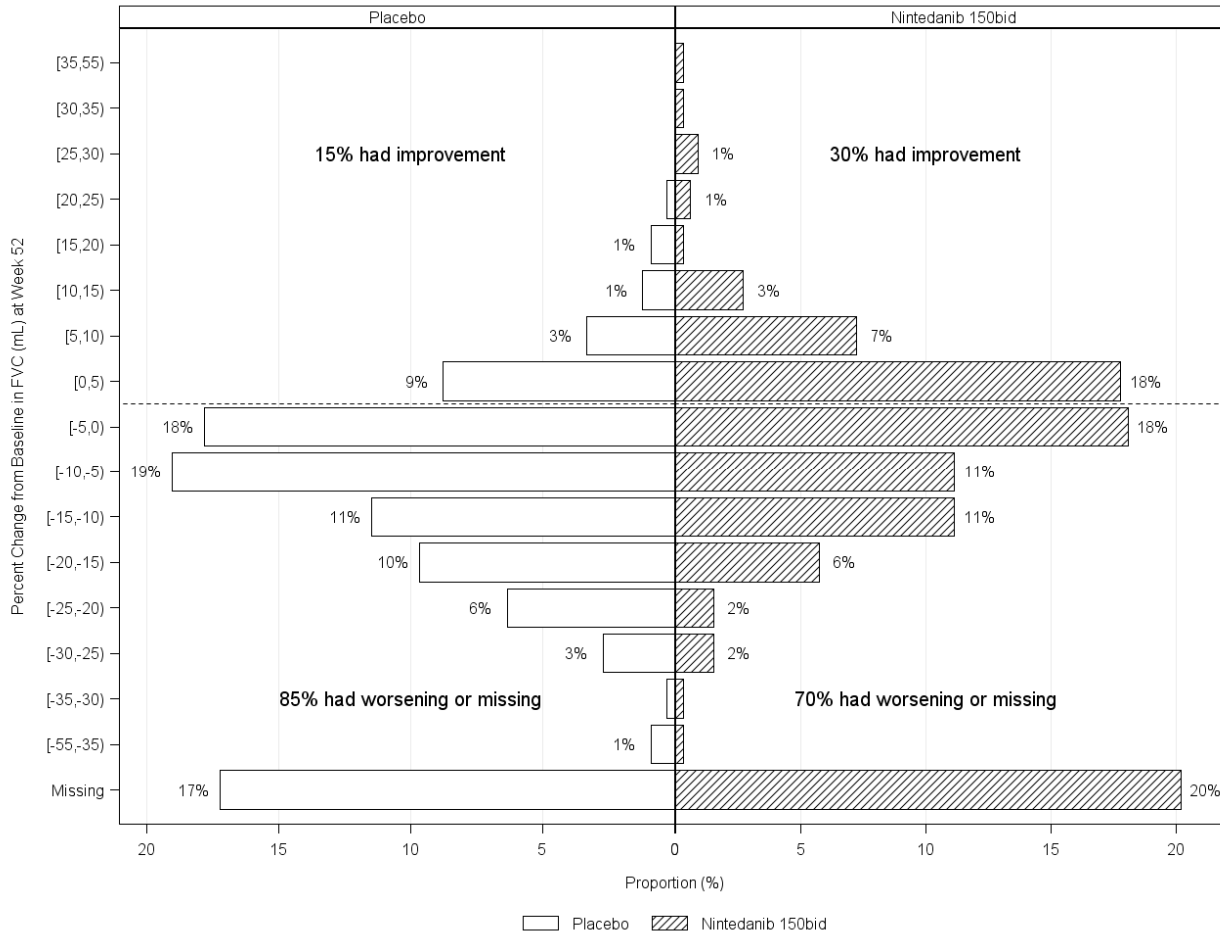

^a Patients classified as having missing FVC data at Week 52 are those with no FVC assessment between Day 310 and Day 373. bid = twice daily

Time to First Acute ILD Exacerbation

Acute ILD exacerbation was defined as unexplained worsening or development of dyspnea within 30 days, new diffuse pulmonary infiltrates on chest x-ray, and/or new HRCT parenchymal abnormalities with no pneumothorax or pleural effusion, and exclusion of alternative causes. Acute ILD exacerbations were not adjudicated.

The risk of first acute ILD exacerbation did not show a statistically significant difference between the OFEV group compared to placebo (52 week treatment period: HR 0.72, (95% CI: 0.38, 1.37); whole trial: HR 0.63 (95% CI: 0.37, 1.07)).

Survival

Survival was evaluated for OFEV compared to placebo in Study 5 to support the primary endpoint (FVC). All-cause mortality was assessed over the study duration and available follow-up period, irrespective of cause of death and whether patients continued treatment. All-cause mortality did not show a statistically significant difference (52 week treatment period: HR 0.94 (95% CI: 0.47, 1.86); whole trial: HR 0.78 (95% CI: 0.50, 1.21)).

14.3 Systemic Sclerosis-Associated Interstitial Lung Disease

The clinical efficacy of nintedanib has been studied in patients with SSc-ILD in a randomized, double-blind, placebo-controlled phase 3 trial (Study 4 [NCT02597933]). A total of 580 patients were randomized in a 1:1 ratio to receive either OFEV 150 mg twice daily or matching placebo for at least 52 weeks, of which 576 patients were treated. Randomization was stratified by anti-topoisomerase antibody (ATA) status. Individual patients remained on blinded trial treatment for up to 100 weeks. The primary endpoint was the annual rate of decline in FVC over 52 weeks. The absolute change from baseline in the modified Rodnan skin score (mRSS) at Week 52 was a key secondary endpoint. Mortality over the whole trial was an additional secondary endpoint.

Patients were diagnosed with SSc-ILD based upon the 2013 American College of Rheumatology / European League Against Rheumatism classification criteria for SSc with onset of disease (first non-Raynaud symptom) of less than 7 years and greater than or equal to 10% fibrosis on a chest high resolution computed tomography (HRCT) scan conducted within the previous 12 months. Patients were required to have an FVC greater than or equal to 40% of predicted and a DLCO 30-89% of predicted. Patients with relevant airways obstruction (i.e., pre-bronchodilator FEV₁/FVC less than 0.7) or previous or planned hematopoietic stem cell transplant were excluded from the trial. Patients with greater than 1.5 times ULN of ALT, AST, or bilirubin, patients with a known risk or predisposition to bleeding, patients receiving a full dose of anticoagulation treatment, and patients with a recent history of myocardial infarction or stroke were excluded from the study. Patients were excluded if they had significant pulmonary hypertension, more than three digital fingertip ulcers, a history of severe digital necrosis requiring hospitalization, or a history of scleroderma renal crisis. Patients were also excluded if they received other investigational therapy, previous treatment with nintedanib or pirfenidone, azathioprine within 8 weeks prior to randomization, or cyclophosphamide or cyclosporine A within 6 months prior to randomization.

The majority of patients were female (75%). Patients were mostly Caucasian (67%), Asian (25%), or Black (6%). The mean age was 54 years. Overall, 52% of patients had diffuse cutaneous systemic sclerosis (SSc) and 48% had limited cutaneous SSc. The mean time since first onset of a non-Raynaud symptom was 3.49 years. At baseline, 49% of patients were on stable therapy with mycophenolate.

Annual Rate of Decline in FVC

The annual rate of decline of FVC (in mL) over 52 weeks was significantly reduced by 41 mL in patients receiving OFEV compared to patients receiving placebo, corresponding to a relative treatment effect of 44%. See Table 5.

Table 5 Annual Rate of Decline in FVC (mL) in Study 4

	OFEV 150 mg twice daily	Placebo
Number of analyzed patients	287	288
Adjusted rate of decline over 52 weeks	-52	-93
Comparison vs placebo Difference ^a	41	
95% CI	(3, 79)	

^aBased on a random coefficient regression model, adjusted for gender, height, age, ATA status, FVC at baseline, FVC at baseline-by-time

Figure 7 displays the change from baseline over time in both treatment groups. When the mean observed FVC change from baseline was plotted over time, the curves diverged at all timepoints through Week 52. Separation of the mean values is seen after 12 weeks of treatment.

Figure 7 Mean (SEM) Observed FVC Change from Baseline (mL) Over Time in Study 4

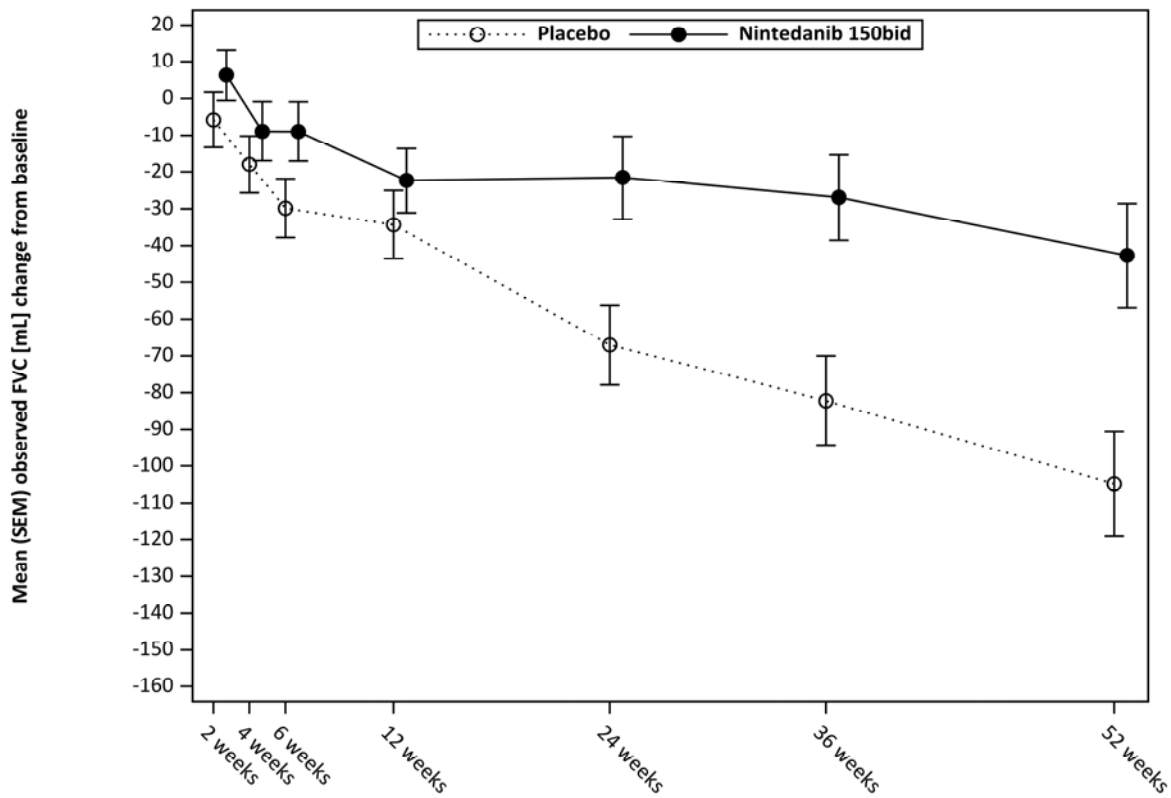

Number of patients

Placebo	283	281	280	283	280	268	257
Nintedanib 150bid	283	281	273	278	265	262	241

bid = twice daily

In two pre-specified subgroup efficacy analyses, the mean treatment difference in FVC decline at 52 weeks in patients were examined by region and mycophenolate use (Figure 8).

Figure 8 Subgroup Analyses of the Mean Treatment Difference in FVC (mL) Decline at Week 52 by Region and Mycophenolate Use (Study 4)

	Placebo		Nintedanib 150bid		Difference [95% CI]
	N	Rate of Decline	N	Rate of Decline	
Region					
Asia	71	-92	59	-48	43 [-37; 124]
Europe	126	-107	139	-67	40 [-17; 96]
Canada and United States	73	-52	69	-42	10 [-66; 86]
Rest of World	18	-176	20	2	178 [28; 329]
Mycophenolate use at baseline					
Yes	140	-67	138	-40	26 [-28; 81]
No	148	-119	149	-64	55 [2; 109]
ALL	288	-93	287	-52	41 [3; 79]

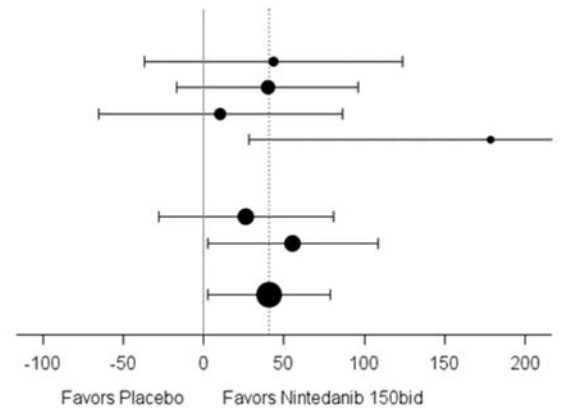

Percent Change from Baseline in Forced Vital Capacity

Figure 9 presents the percent change from baseline in FVC in mL at Week 52 for Study 4. For the majority of patients, the decline in lung function was less on OFEV than on placebo.

Figure 9 Histogram of the Percent Change in FVC (mL) from Baseline to Week 52 According to Treatment and Percent Increments or Decrements of 5 (Study 4)^a

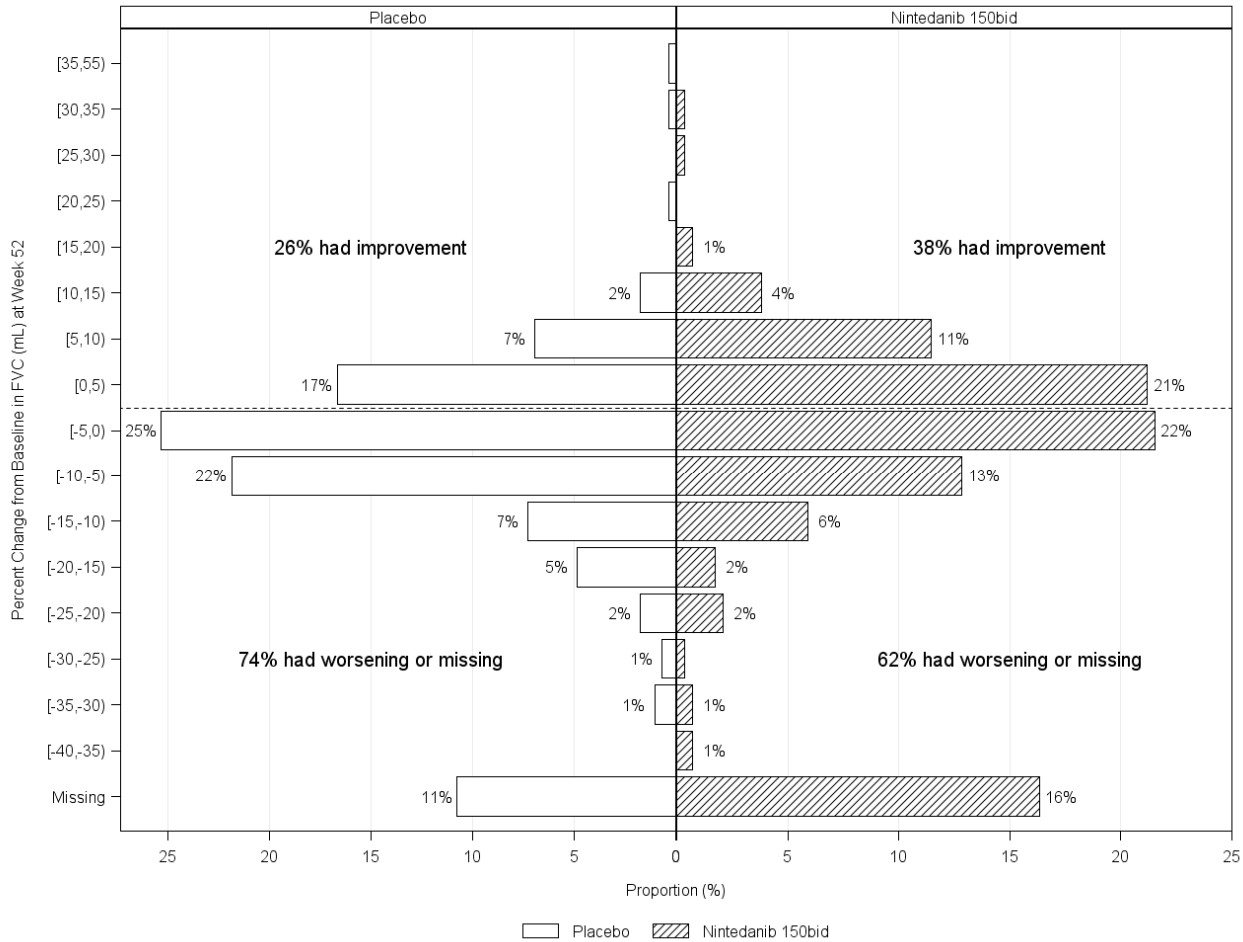

^a Patients classified as having missing FVC data at Week 52 are those with no FVC assessment between Day 310 and Day 373. bid = twice daily

Modified Rodnan Skin Score

No benefit in mRSS was observed in patients receiving OFEV. The adjusted mean absolute change from baseline in mRSS at Week 52 was comparable between the OFEV group (-2.17 (95% CI: -2.69, -1.65)) and the placebo group (-1.96 (95% CI: -2.48, -1.45)). The adjusted mean difference between the treatment groups was -0.21 (95% CI: -0.94, 0.53).

Survival

No difference in survival was observed in an exploratory analysis of mortality over the whole trial (OFEV: n=10 (3.5%) vs. placebo: n=9 (3.1%)). The analysis of time to death over the whole trial resulted in a HR of 1.16 (95% CI: 0.47, 2.84).

16 HOW SUPPLIED/STORAGE AND HANDLING

150 mg: brown, opaque, oblong, soft capsules imprinted in black with the Boehringer Ingelheim company symbol and "150". They are packaged in HDPE bottles with a child-resistant closure, available as follows:
Bottles of 60 NDC: 0597-0145-60

100 mg: peach, opaque, oblong, soft capsules imprinted in black with the Boehringer Ingelheim company symbol and "100". They are packaged in HDPE bottles with a child-resistant closure, available as follows:
Bottles of 60 NDC: 0597-0143-60

Storage

Store at 25°C (77°F); excursions permitted to 15° to 30°C (59° to 86°F) [see USP Controlled Room Temperature]. Protect from exposure to high humidity and avoid excessive heat. If repackaged, use USP tight container. Keep out of reach of children.

17 PATIENT COUNSELING INFORMATION

Advise the patient to read the FDA-approved patient labeling (Patient Information).

Elevated Liver Enzymes and Drug-Induced Liver Injury

Advise patients that they will need to undergo liver function testing periodically. Advise patients to immediately report any symptoms of a liver problem (e.g., skin or the whites of eyes turn yellow, urine turns dark or brown (tea colored), pain on the right side of stomach, bleed or bruise more easily than normal, lethargy, loss of appetite) [see *Warnings and Precautions (5.2)*].

Gastrointestinal Disorders

Inform patients that gastrointestinal disorders such as diarrhea, nausea, and vomiting were the most commonly reported gastrointestinal events occurring in patients who received OFEV. Advise patients that their healthcare provider may recommend hydration, antidiarrheal medications (e.g., loperamide), or anti-emetic medications to treat these side effects. Temporary dosage reductions or discontinuations may be required. Instruct patients to contact their healthcare provider at the first signs of diarrhea or for any severe or persistent diarrhea, nausea, or vomiting [see *Warnings and Precautions (5.3)* and *Adverse Reactions (6.1)*].

Embryo-Fetal Toxicity

Counsel patients on pregnancy prevention and planning. Advise females of reproductive potential of the potential risk to a fetus and to avoid becoming pregnant while receiving treatment with OFEV. Advise females of reproductive potential to use highly effective contraception during treatment, and for at least 3 months after taking the last dose of OFEV. Advise women using hormonal contraceptives to add a barrier method. Advise female patients to notify their doctor if they become pregnant or suspect they are pregnant during therapy with OFEV [see *Warnings and Precautions (5.4)* and *Use in Specific Populations (8.1, 8.3)*].

Arterial Thromboembolic Events

Advise patients about the signs and symptoms of acute myocardial ischemia and other arterial thromboembolic events and the urgency to seek immediate medical care for these conditions [see *Warnings and Precautions (5.5)*].

Risk of Bleeding

Bleeding events have been reported. Advise patients to report unusual bleeding [see *Warnings and Precautions (5.6)*].

Gastrointestinal Perforation

Serious gastrointestinal perforation events have been reported. Advise patients to report signs and symptoms of gastrointestinal perforation [*see Warnings and Precautions (5.7)*].

Lactation

Advise patients that breastfeeding is not recommended while taking OFEV [*see Use in Specific Populations (8.2)*].

Smokers

Encourage patients to stop smoking prior to treatment with OFEV and to avoid smoking when using OFEV [*see Clinical Pharmacology (12.3)*].

Administration

Instruct patients to swallow OFEV capsules whole with liquid and not to chew or crush the capsules due to the bitter taste. Advise patients to not make up for a missed dose [*see Dosage and Administration (2)*].

Distributed by:

Boehringer Ingelheim Pharmaceuticals, Inc.
Ridgefield, CT 06877 USA

Licensed from:

Boehringer Ingelheim International GmbH

OFEV is a registered trademark of and used under license from Boehringer Ingelheim International GmbH.

Copyright © 2020 Boehringer Ingelheim International GmbH
ALL RIGHTS RESERVED

IT6996KB272020

Patient Information
OFEV® (OH-fev)
(nintedanib)
capsules

What is the most important information I should know about OFEV?

- OFEV can cause birth defects or death to an unborn baby. Women should not become pregnant while taking OFEV. Women who are able to become pregnant should have a pregnancy test before starting treatment with OFEV.
- Women who are able to become pregnant should use highly effective birth control during treatment and for at least 3 months after treatment. Talk with your doctor about what birth control method is right for you during this time.
- Women using hormonal birth control should also use a barrier method of birth control (such as male condoms or spermicide).
- If you become pregnant or think you are pregnant while taking OFEV, tell your doctor right away.

What is OFEV?

- OFEV is a prescription medicine used:
 - to treat people with a lung disease called idiopathic pulmonary fibrosis (IPF).
 - to treat people with a chronic (long lasting) interstitial lung disease in which lung fibrosis continues to worsen (progress).
 - to slow the rate of decline in lung function in people with systemic sclerosis-associated interstitial lung disease (SSc-ILD) (also known as scleroderma-associated ILD).
- It is not known if OFEV is safe and effective in children.

What should I tell my doctor before taking OFEV?

Before you take OFEV, tell your doctor about all of your medical conditions, including if you:

- have liver problems.
- have heart problems.
- have a history of blood clots.
- have a bleeding problem or a family history of a bleeding problem.
- have had recent surgery in your stomach (abdominal) area.
- are a smoker.
- are pregnant or plan to become pregnant. OFEV can harm your unborn baby. OFEV can cause birth defects or death to an unborn baby. See “**What is the most important information I should know about OFEV?**”
- are breastfeeding or plan to breastfeed. It is not known if OFEV passes into your breast milk. You **should not** breastfeed while taking OFEV.

Tell your doctor about all the medicines you take, including prescription and over-the-counter medicines, vitamins, and herbal supplements such as St. John’s wort. Keep a list of the medicines you take and show it to your doctor and pharmacist when you get a new medicine.

How should I take OFEV?

- Take OFEV exactly as your doctor tells you to take it.
- Your doctor will tell you how much OFEV to take and when to take it.
- Take OFEV with food. Swallow the OFEV capsules whole with a liquid.
- **Do not** chew or crush OFEV capsules.
- If you miss a dose of OFEV, take your next dose at your regular time. **Do not** take the missed dose.
- **Do not** take more than 300 mg of OFEV in 1 day.
- If you take too much OFEV, call your doctor or go to the nearest hospital emergency room right away.
- Your doctor should do certain blood tests before you start taking OFEV.

What are the possible side effects of OFEV?

OFEV may cause serious side effects, including:

- See “**What is the most important information I should know about OFEV?**”
- **liver problems.** Call your doctor right away if you have unexplained symptoms such as yellowing of your skin or the white part of your eyes (jaundice), dark or brown (tea colored) urine, pain on the upper right side of your stomach area (abdomen), bleeding or bruising more easily than normal, feeling tired, or loss of appetite. Your doctor will do blood tests to check how well your liver is working before starting and during your treatment with OFEV.
- **diarrhea, nausea, and vomiting.** While you are taking OFEV, your doctor may recommend that you drink fluids or take medicine to treat these side effects. Tell your doctor if you have diarrhea, nausea, or vomiting or if these symptoms do not go away or become worse. Tell your doctor if you are taking over-the-counter laxatives, stool softeners, and other medicines or dietary supplements that can cause diarrhea.

- **heart attack.** Tell your doctor right away if you have symptoms of a heart problem. These symptoms may include chest pain or pressure, pain in your arms, back, neck or jaw, or shortness of breath.
- **stroke.** Tell your doctor right away if you have symptoms of a stroke. These symptoms may include numbness or weakness on 1 side of your body, trouble talking, headache, or dizziness.
- **bleeding problems.** OFEV may increase your chances of having bleeding problems. Tell your doctor if you have unusual bleeding, bruising, or wounds that do not heal. Tell your doctor if you are taking a blood thinner, including prescription blood thinners and over-the-counter aspirin.
- **tear in your stomach or intestinal wall (perforation).** OFEV may increase your chances of having a tear in your stomach or intestinal wall. Tell your doctor if you have pain or swelling in your stomach area.

The most common side effects of OFEV are diarrhea, nausea, stomach pain, vomiting, liver problems, decreased appetite, headache, weight loss, and high blood pressure.

These are not all the possible side effects of OFEV. For more information, ask your doctor or pharmacist.

Call your doctor for medical advice about side effects. You may report side effects to FDA at 1-800-FDA-1088.

How should I store OFEV?

- Store OFEV at room temperature between 68°F to 77°F (20°C to 25°C).
- Keep OFEV dry and protect from high heat.

Keep OFEV and all medicines out of the reach of children.

General information about the safe and effective use of OFEV.

Medicines are sometimes prescribed for purposes other than those listed in a Patient Information leaflet. Do not use OFEV for a condition for which it was not prescribed. Do not give OFEV to other people, even if they have the same symptoms you have. It may harm them. This Patient Information leaflet summarizes the most important information about OFEV. If you would like more information, talk to your doctor. You can ask your pharmacist or doctor for information about OFEV that is written for health professionals.

For more information, go to www.ofev.com or call Boehringer Ingelheim Pharmaceuticals, Inc. at 1-800-542-6257, or (TTY) 1-800-459-9906, or scan the code below to go to www.ofev.com.



What are the ingredients in OFEV?

Active ingredient: nintedanib

Inactive ingredients: Fill Material: triglycerides, hard fat, lecithin. Capsule Shell: gelatin, glycerol, titanium dioxide, red ferric oxide, yellow ferric oxide, black ink

Distributed by: Boehringer Ingelheim Pharmaceuticals, Inc. Ridgefield, CT 06877 USA

OFEV is a registered trademark of and used under license from Boehringer Ingelheim International GmbH.

Copyright © 2020 Boehringer Ingelheim International GmbH, ALL RIGHTS RESERVED

IT6996KB272020

This Patient Information has been approved by the U.S. Food and Drug Administration.

Revised: March 2020

HIGHLIGHTS OF PRESCRIBING INFORMATION

These highlights do not include all the information needed to use PROMACTA safely and effectively. See full prescribing information for PROMACTA.

PROMACTA® (eltrombopag) tablets, for oral use

PROMACTA® (eltrombopag) for oral suspension

Initial U.S. Approval: 2008

WARNING: RISK FOR HEPATIC DECOMPENSATION IN PATIENTS WITH CHRONIC HEPATITIS C and RISK OF HEPATOTOXICITY

See full prescribing information for complete boxed warning.

In patients with chronic hepatitis C, PROMACTA in combination with interferon and ribavirin may increase the risk of hepatic decompensation. (5.1)

PROMACTA may increase the risk of severe and potentially life-threatening hepatotoxicity. Monitor hepatic function and discontinue dosing as recommended. (5.2)

RECENT MAJOR CHANGES

Dosage and Administration, Administration (2.4)

04/2020

INDICATIONS AND USAGE

PROMACTA is a thrombopoietin receptor agonist indicated:

- for the treatment of thrombocytopenia in adult and pediatric patients 1 year and older with chronic immune thrombocytopenia (ITP) who have had an insufficient response to corticosteroids, immunoglobulins, or splenectomy. PROMACTA should be used only in patients with ITP whose degree of thrombocytopenia and clinical condition increase the risk for bleeding. (1.1)
- for the treatment of thrombocytopenia in patients with chronic hepatitis C to allow the initiation and maintenance of interferon-based therapy. PROMACTA should be used only in patients with chronic hepatitis C whose degree of thrombocytopenia prevents the initiation of interferon-based therapy or limits the ability to maintain interferon-based therapy. (1.2)
- in combination with standard immunosuppressive therapy for the first-line treatment of adult and pediatric patients 2 years and older with severe aplastic anemia. (1.3)
- for the treatment of patients with severe aplastic anemia who have had an insufficient response to immunosuppressive therapy. (1.3)

Limitations of Use:

- PROMACTA is not indicated for the treatment of patients with myelodysplastic syndrome (MDS). (1.4)
- Safety and efficacy have not been established in combination with direct-acting antiviral agents used without interferon for treatment of chronic hepatitis C infection. (1.4)

DOSAGE AND ADMINISTRATION

- Take PROMACTA without a meal or with a meal low in calcium (≤ 50 mg). Take Promacta at least 2 hours before or 4 hours after any medications or products containing polyvalent cations such as antacids, calcium-rich foods, and mineral supplements. (2.4, 7.1, 12.3)
- **Chronic ITP:** Initiate PROMACTA at 50 mg once daily for most adult and pediatric patients 6 years and older, and at 25 mg once daily for pediatric patients aged 1 to 5 years. Dose reductions are needed for patients with hepatic impairment and some patients of Asian ancestry. Adjust to maintain platelet count greater than or equal to $50 \times 10^9/L$. Do not exceed 75 mg per day. (2.1, 8.6, 8.7)

- **Chronic Hepatitis C-associated Thrombocytopenia:** Initiate PROMACTA at 25 mg once daily for all patients. Adjust to achieve target platelet count required to initiate antiviral therapy. Do not exceed a daily dose of 100 mg. (2.2)
- **First-line Severe Aplastic Anemia:** Initiate PROMACTA once daily at 2.5 mg/kg (in pediatric patients aged 2 to 5 years old), 75 mg (pediatric patients aged 6 to 11 years old), or 150 mg for patients aged 12 years and older concurrently with standard immunosuppressive therapy. Reduce initial dose in patients of Asian ancestry. Modify dosage for toxicity or elevated platelet counts. (2.3, 8.7)
- **Refractory Severe Aplastic Anemia:** Initiate PROMACTA at 50 mg once daily. Reduce initial dose in patients with hepatic impairment or patients of Asian ancestry. Adjust to maintain platelet count greater than $50 \times 10^9/L$. Do not exceed 150 mg per day. (2.3, 8.6, 8.7)

DOSAGE FORMS AND STRENGTHS

- Tablets: 12.5 mg, 25 mg, 50 mg, and 75 mg (3)
- For oral suspension: 12.5 mg and 25 mg (3)

CONTRAINDICATIONS

None. (4)

WARNINGS AND PRECAUTIONS

- **Hepatotoxicity:** Monitor liver function before and during therapy. (5.2)
- Increased Risk of Death and Progression of Myelodysplastic Syndromes to Acute Myeloid Leukemia (5.3)
- **Thrombotic/Thromboembolic Complications:** Portal vein thrombosis has been reported in patients with chronic liver disease receiving PROMACTA. Monitor platelet counts regularly. (5.4)

ADVERSE REACTIONS

Across all indications, the most common adverse reactions ($\geq 20\%$ in any indication) were: anemia, nausea, pyrexia, alanine aminotransferase increased, cough, fatigue, headache, and diarrhea. (6.1)

To report SUSPECTED ADVERSE REACTIONS, contact Novartis Pharmaceuticals Corporation at 1-888-669-6682 or FDA at 1-800-FDA-1088 or www.fda.gov/medwatch.

USE IN SPECIFIC POPULATIONS

- Lactation: Advise women not to breastfeed during treatment. (8.2)

See 17 for PATIENT COUNSELING INFORMATION and Medication Guide.

Revised: 04/2020

FULL PRESCRIBING INFORMATION: CONTENTS***WARNING: RISK FOR HEPATIC DECOMPENSATION IN PATIENTS WITH CHRONIC HEPATITIS C and RISK OF HEPATOTOXICITY****1 INDICATIONS AND USAGE**

- 1.1 Treatment of Thrombocytopenia in Patients With Chronic Immune Thrombocytopenia
- 1.2 Treatment of Thrombocytopenia in Patients With Hepatitis C Infection
- 1.3 Treatment of Severe Aplastic Anemia
- 1.4 Limitations of Use

2 DOSAGE AND ADMINISTRATION

- 2.1 Chronic Immune Thrombocytopenia
- 2.2 Chronic Hepatitis C-associated Thrombocytopenia
- 2.3 Severe Aplastic Anemia
- 2.4 Administration

3 DOSAGE FORMS AND STRENGTHS**4 CONTRAINDICATIONS****5 WARNINGS AND PRECAUTIONS**

- 5.1 Hepatic Decompensation in Patients With Chronic Hepatitis C
- 5.2 Hepatotoxicity
- 5.3 Increased Risk of Death and Progression of Myelodysplastic Syndromes to Acute Myeloid Leukemia
- 5.4 Thrombotic/Thromboembolic Complications
- 5.5 Cataracts

6 ADVERSE REACTIONS

- 6.1 Clinical Trials Experience
- 6.2 Postmarketing Experience

7 DRUG INTERACTIONS

- 7.1 Polyvalent Cations (Chelation)

- 7.2 Transporters

- 7.3 Protease Inhibitors

- 7.4 Peginterferon alfa-2a/b Therapy

8 USE IN SPECIFIC POPULATIONS

- 8.1 Pregnancy

- 8.2 Lactation

- 8.3 Females and Males of Reproductive Potential

- 8.4 Pediatric Use

- 8.5 Geriatric Use

- 8.6 Hepatic Impairment

- 8.7 Ethnicity

10 OVERDOSAGE**11 DESCRIPTION****12 CLINICAL PHARMACOLOGY**

- 12.1 Mechanism of Action

- 12.2 Pharmacodynamics

- 12.3 Pharmacokinetics

13 NONCLINICAL TOXICOLOGY

- 13.1 Carcinogenesis, Mutagenesis, Impairment of Fertility

- 13.2 Animal Pharmacology and/or Toxicology

14 CLINICAL STUDIES

- 14.1 Chronic ITP

- 14.2 Chronic Hepatitis C-associated Thrombocytopenia

- 14.3 Severe Aplastic Anemia

16 HOW SUPPLIED/STORAGE AND HANDLING

- 16.1 Tablets

- 16.2 For Oral Suspension

17 PATIENT COUNSELING INFORMATION

*Sections or subsections omitted from the full prescribing information are not listed.

FULL PRESCRIBING INFORMATION

WARNING: RISK FOR HEPATIC DECOMPENSATION IN PATIENTS WITH CHRONIC HEPATITIS C and RISK OF HEPATOTOXICITY

In patients with chronic hepatitis C, PROMACTA in combination with interferon and ribavirin may increase the risk of hepatic decompensation [see *Warnings and Precautions* (5.1)].

PROMACTA may increase the risk of severe and potentially life-threatening hepatotoxicity. Monitor hepatic function and discontinue dosing as recommended [see *Warnings and Precautions* (5.2)].

1 INDICATIONS AND USAGE

1.1 Treatment of Thrombocytopenia in Patients With Chronic Immune Thrombocytopenia

PROMACTA is indicated for the treatment of thrombocytopenia in adult and pediatric patients 1 year and older with chronic immune thrombocytopenia (ITP) who have had an insufficient response to corticosteroids, immunoglobulins, or splenectomy. PROMACTA should be used only in patients with ITP whose degree of thrombocytopenia and clinical condition increase the risk for bleeding.

1.2 Treatment of Thrombocytopenia in Patients With Hepatitis C Infection

PROMACTA is indicated for the treatment of thrombocytopenia in patients with chronic hepatitis C to allow the initiation and maintenance of interferon-based therapy. PROMACTA should be used only in patients with chronic hepatitis C whose degree of thrombocytopenia prevents the initiation of interferon-based therapy or limits the ability to maintain interferon-based therapy.

1.3 Treatment of Severe Aplastic Anemia

- PROMACTA is indicated in combination with standard immunosuppressive therapy (IST) for the first-line treatment of adult and pediatric patients 2 years and older with severe aplastic anemia.
- PROMACTA is indicated for the treatment of patients with severe aplastic anemia who have had an insufficient response to immunosuppressive therapy.

1.4 Limitations of Use

- PROMACTA is not indicated for the treatment of patients with myelodysplastic syndromes (MDS) [see *Warnings and Precautions* (5.3)].
- Safety and efficacy have not been established in combination with direct-acting antiviral agents used without interferon for treatment of chronic hepatitis C infection.

2 DOSAGE AND ADMINISTRATION

2.1 Chronic Immune Thrombocytopenia

Use the lowest dose of PROMACTA to achieve and maintain a platelet count greater than or equal to $50 \times 10^9/L$ as necessary to reduce the risk for bleeding. Dose adjustments are based upon the platelet count response. Do not use PROMACTA to normalize platelet counts [see *Warnings and Precautions* (5.4)]. In clinical trials, platelet counts generally increased within 1 to 2 weeks after starting PROMACTA and decreased within 1 to 2 weeks after discontinuing PROMACTA [see *Clinical Studies* (14.1)].

Initial Dose Regimen: *Adult and Pediatric Patients 6 Years and Older with ITP:* Initiate PROMACTA at a dose of 50 mg once daily, except in patients who are of Asian ancestry (such as Chinese, Japanese, Taiwanese, or Korean) or who have mild to severe hepatic impairment (Child-Pugh Class A, B, C).

For patients of Asian ancestry with ITP, initiate PROMACTA at a reduced dose of 25 mg once daily [see *Use in Specific Populations* (8.7), *Clinical Pharmacology* (12.3)].

For patients with ITP and mild, moderate, or severe hepatic impairment (Child-Pugh Class A, B, C), initiate PROMACTA at a reduced dose of 25 mg once daily [see *Use in Specific Populations* (8.6), *Clinical Pharmacology* (12.3)].

For patients of Asian ancestry with ITP and hepatic impairment (Child-Pugh Class A, B, C), consider initiating PROMACTA at a reduced dose of 12.5 mg once daily [see *Clinical Pharmacology* (12.3)].

Pediatric Patients with ITP Aged 1 to 5 Years: Initiate PROMACTA at a dose of 25 mg once daily [see *Use in Specific Populations* (8.7), *Clinical Pharmacology* (12.3)].

Monitoring and Dose Adjustment: After initiating PROMACTA, adjust the dose to achieve and maintain a platelet count greater than or equal to $50 \times 10^9/L$ as necessary to reduce the risk for bleeding. Do not exceed a dose of 75 mg daily. Monitor clinical hematology and liver tests regularly throughout therapy with PROMACTA and modify the dosage regimen of PROMACTA based on platelet counts as outlined in Table 1. During therapy with PROMACTA, assess complete blood counts (CBCs) with differentials, including platelet counts, weekly until a stable platelet count has been achieved. Obtain CBCs with differentials, including platelet counts, monthly thereafter.

When switching between the oral suspension and tablet, assess platelet counts weekly for 2 weeks, and then follow standard monthly monitoring.

Table 1. Dose Adjustments of PROMACTA in Patients With Chronic Immune Thrombocytopenia

Platelet Count Result	Dose Adjustment or Response
< $50 \times 10^9/L$ following at least 2 weeks of PROMACTA	Increase daily dose by 25 mg to a maximum of 75 mg/day. For patients taking 12.5 mg once daily, increase the dose to 25 mg daily before increasing the dose amount by 25 mg.
$\geq 200 \times 10^9/L$ to $\leq 400 \times 10^9/L$ at any time	Decrease the daily dose by 25 mg. Wait 2 weeks to assess the effects of this and any subsequent dose adjustments. For patients taking 25 mg once daily, decrease the dose to 12.5 mg once daily.
> $400 \times 10^9/L$	Stop PROMACTA; increase the frequency of platelet monitoring to twice weekly. Once the platelet count is < $150 \times 10^9/L$, reinstitute therapy at a daily dose reduced by 25 mg. For patients taking 25 mg once daily, reinstitute therapy at a daily dose of 12.5 mg.
> $400 \times 10^9/L$ after 2 weeks of therapy at lowest dose of PROMACTA	Discontinue PROMACTA.

In patients with ITP and hepatic impairment (Child-Pugh Class A, B, C), after initiating PROMACTA or after any subsequent dosing increase, wait 3 weeks before increasing the dose.

Modify the dosage regimen of concomitant ITP medications, as medically appropriate, to avoid excessive increases in platelet counts during therapy with PROMACTA. Do not administer more than one dose of PROMACTA within any 24-hour period.

Discontinuation: Discontinue PROMACTA if the platelet count does not increase to a level sufficient to avoid clinically important bleeding after 4 weeks of therapy with PROMACTA at the maximum daily dose of 75 mg. Excessive platelet count responses, as outlined in Table 1, or important liver test abnormalities also necessitate

discontinuation of PROMACTA [see *Warnings and Precautions (5.2)*]. Obtain CBCs with differentials, including platelet counts, weekly for at least 4 weeks following discontinuation of PROMACTA.

2.2 Chronic Hepatitis C-associated Thrombocytopenia

Use the lowest dose of PROMACTA to achieve and maintain a platelet count necessary to initiate and maintain antiviral therapy with pegylated interferon and ribavirin. Dose adjustments are based upon the platelet count response. Do not use PROMACTA to normalize platelet counts [see *Warnings and Precautions (5.4)*]. In clinical trials, platelet counts generally began to rise within the first week of treatment with PROMACTA [see *Clinical Studies (14.2)*].

Initial Dose Regimen: Initiate PROMACTA at a dose of 25 mg once daily.

Monitoring and Dose Adjustment: Adjust the dose of PROMACTA in 25-mg increments every 2 weeks as necessary to achieve the target platelet count required to initiate antiviral therapy. Monitor platelet counts every week prior to starting antiviral therapy.

During antiviral therapy, adjust the dose of PROMACTA to avoid dose reductions of peginterferon. Monitor CBCs with differentials, including platelet counts, weekly during antiviral therapy until a stable platelet count is achieved. Monitor platelet counts monthly thereafter. Do not exceed a dose of 100 mg daily. Monitor clinical hematology and liver tests regularly throughout therapy with PROMACTA.

For specific dosage instructions for peginterferon or ribavirin, refer to their respective prescribing information.

Table 2. Dose Adjustments of PROMACTA in Adults With Thrombocytopenia Due to Chronic Hepatitis C

Platelet Count Result	Dose Adjustment or Response
< 50 x 10 ⁹ /L following at least 2 weeks of PROMACTA	Increase daily dose by 25 mg to a maximum of 100 mg/day.
≥ 200 x 10 ⁹ /L to ≤ 400 x 10 ⁹ /L at any time	Decrease the daily dose by 25 mg. Wait 2 weeks to assess the effects of this and any subsequent dose adjustments.
> 400 x 10 ⁹ /L	Stop PROMACTA; increase the frequency of platelet monitoring to twice weekly. Once the platelet count is < 150 x 10 ⁹ /L, reinstitute therapy at a daily dose reduced by 25 mg. For patients taking 25 mg once daily, reinstitute therapy at a daily dose of 12.5 mg.
> 400 x 10 ⁹ /L after 2 weeks of therapy at lowest dose of PROMACTA	Discontinue PROMACTA.

Discontinuation: The prescribing information for pegylated interferon and ribavirin include recommendations for antiviral treatment discontinuation for treatment futility. Refer to pegylated interferon and ribavirin prescribing information for discontinuation recommendations for antiviral treatment futility.

PROMACTA should be discontinued when antiviral therapy is discontinued. Excessive platelet count responses, as outlined in Table 2, or important liver test abnormalities also necessitate discontinuation of PROMACTA [see *Warnings and Precautions (5.2)*].

2.3 Severe Aplastic Anemia

First-line Severe Aplastic Anemia

Initiate PROMACTA concurrently with standard immunosuppressive therapy [see *Clinical Studies (14.3)*].

Initial Dose Regimen:

The recommended initial dose regimen is listed in Table 3. Do not exceed the initial dose of PROMACTA.

Table 3. Recommended Initial PROMACTA Dose Regimen in the First-Line Treatment of Severe Aplastic Anemia

Age	Dose Regimen
Patients 12 Years and Older	150 mg once daily for 6 months
Pediatric Patients 6 to 11 Years	75 mg once daily for 6 months
Pediatric Patients 2 to 5 Years	2.5 mg/kg once daily for 6 months

For patients with severe aplastic anemia of Asian ancestry (such as Chinese, Japanese, Taiwanese, Korean, or Thai) or those with mild, moderate, or severe hepatic impairment (Child-Pugh Class A, B, C), decrease the initial PROMACTA dose by 50% as listed in Table 4 [see *Use in Specific Populations (8.6, 8.7), Clinical Pharmacology (12.3)*].

If baseline alanine aminotransferase (ALT) or aspartate aminotransferase (AST) levels are $> 6 \times$ upper limit of normal (ULN), do not initiate PROMACTA until transaminase levels are $< 5 \times$ ULN. Determine the initial dose for these patients based on Table 3 or Table 4.

Table 4. Recommended Initial PROMACTA Dose Regimen for Patients of Asian Ancestry or Those With Mild, Moderate, or Severe Hepatic Impairment (Child-Pugh Class A, B, C) in the First-Line Treatment of Severe Aplastic Anemia

Age	Dose Regimen
Patients 12 Years and Older	75 mg once daily for 6 months
Pediatric Patients 6 to 11 Years	37.5 mg once daily for 6 months
Pediatric Patients 2 to 5 Years	1.25 mg/kg once daily for 6 months

Monitoring and Dose Adjustment for PROMACTA: Perform clinical hematology and liver tests regularly throughout therapy with PROMACTA [see *Warnings and Precautions (5.2)*].

Modify the dosage regimen of PROMACTA based on platelet counts as outlined in Table 5.

Table 5. Dose Adjustments of PROMACTA for Elevated Platelet Counts in the First-line Treatment of Severe Aplastic Anemia

Platelet Count Result	Dose Adjustment or Response
$> 200 \times 10^9/L$ to $\leq 400 \times 10^9/L$	Decrease the daily dose by 25 mg every 2 weeks to lowest dose that maintains platelet count $\geq 50 \times 10^9/L$. In pediatric patients under 12 years of age, decrease the dose by 12.5 mg.
$> 400 \times 10^9/L$	Discontinue PROMACTA for one week. Once the platelet count is $< 200 \times 10^9/L$, reinstate PROMACTA at a daily dose reduced by 25 mg (or 12.5 mg in pediatric patients under 12 years of age).

Table 6 summarizes the recommendations for dose interruption, reduction, or discontinuation of PROMACTA in the management of elevated liver transaminase levels and thromboembolic events.

Table 6. Recommended Dose Modifications for PROMACTA for ALT or AST Elevations and Thromboembolic Events

Event	Recommendation
ALT or AST Elevations	<p><u>Increase in ALT or AST > 6 x ULN</u> Discontinue PROMACTA. Once ALT or AST is < 5 x ULN, reinitiate PROMACTA at the same dose.</p> <p><u>Increase in ALT or AST > 6 x ULN after reinitiating PROMACTA</u> Discontinue PROMACTA and monitor ALT or AST at least every 3 to 4 days. Once ALT or AST is < 5 x ULN, reinitiate PROMACTA at a daily dose reduced by 25 mg compared to the previous dose.</p> <p><u>If ALT or AST returns to > 6 x ULN on the reduced dose</u> Reduce the daily dose of PROMACTA by 25 mg until ALT or AST is < 5 x ULN.</p> <p>In pediatric patients under 12 years of age, reduce the daily dose by at least 15% to the nearest dose that can be administered.</p>
Thromboembolic events (e.g., deep vein thrombosis, pulmonary embolus, stroke, myocardial infarction)	Discontinue PROMACTA but remain on horse antithymocyte globulin (h-ATG) and cyclosporine.

The total duration of PROMACTA treatment is 6 months.

Refractory Severe Aplastic Anemia

Use the lowest dose of PROMACTA to achieve and maintain a hematologic response. Dose adjustments are based upon the platelet count. Hematologic response requires dose titration, generally up to 150 mg, and may take up to 16 weeks after starting PROMACTA [see *Clinical Studies (14.3)*].

Initial Dose Regimen: Initiate PROMACTA at a dose of 50 mg once daily.

For patients with severe aplastic anemia of Asian ancestry or those with mild, moderate, or severe hepatic impairment (Child-Pugh Class A, B, C), initiate PROMACTA at a reduced dose of 25 mg once daily [see *Use in Specific Populations (8.6, 8.7), Clinical Pharmacology (12.3)*].

Monitoring and Dose Adjustment: Adjust the dose of PROMACTA in 50-mg increments every 2 weeks as necessary to achieve the target platelet count greater than or equal to $50 \times 10^9/L$ as necessary. Do not exceed a dose of 150 mg daily. Monitor clinical hematology and liver tests regularly throughout therapy with PROMACTA and modify the dosage regimen of PROMACTA based on platelet counts as outlined in Table 7.

Table 7. Dose Adjustments of PROMACTA in Patients with Refractory Severe Aplastic Anemia

Platelet Count Result	Dose Adjustment or Response
< 50 x 10 ⁹ /L following at least 2 weeks of PROMACTA	Increase daily dose by 50 mg to a maximum of 150 mg/day. For patients taking 25 mg once daily, increase the dose to 50 mg daily before increasing the dose amount by 50 mg.
≥ 200 x 10 ⁹ /L to ≤ 400 x 10 ⁹ /L at any time	Decrease the daily dose by 50 mg. Wait 2 weeks to assess the effects of this and any subsequent dose adjustments.
> 400 x 10 ⁹ /L	Stop PROMACTA for 1 week. Once the platelet count is < 150 x 10 ⁹ /L, reinitiate therapy at a dose reduced by 50 mg.
> 400 x 10 ⁹ /L after 2 weeks of therapy at lowest dose of PROMACTA	Discontinue PROMACTA.

For patients who achieve tri-lineage response, including transfusion independence, lasting at least 8 weeks: the dose of PROMACTA may be reduced by 50% [see *Clinical Studies (14.3)*]. If counts remain stable after 8 weeks at the reduced dose, then discontinue PROMACTA and monitor blood counts. If platelet counts drop to less than 30 x 10⁹/L, hemoglobin to less than 9 g/dL, or absolute neutrophil count (ANC) to less than 0.5 x 10⁹/L, PROMACTA may be reinitiated at the previous effective dose.

Discontinuation: If no hematologic response has occurred after 16 weeks of therapy with PROMACTA, discontinue therapy. If new cytogenetic abnormalities are observed, consider discontinuation of PROMACTA [see *Adverse Reactions (6.1)*]. Excessive platelet count responses (as outlined in Table 7) or important liver test abnormalities also necessitate discontinuation of PROMACTA [see *Warnings and Precautions (5.2)*].

2.4 Administration

Administration of Tablets and Oral Suspension: Take PROMACTA without a meal or with a meal low in calcium (≤ 50 mg). Take PROMACTA at least 2 hours before or 4 hours after other medications (e.g., antacids), calcium-rich foods (containing > 50 mg calcium e.g., dairy products, calcium-fortified juices, and certain fruits and vegetables), or supplements containing polyvalent cations such as iron, calcium, aluminum, magnesium, selenium, and zinc [see *Drug Interactions (7.1)*, *Clinical Pharmacology (12.3)*].

Do not split, chew, or crush tablets and mix with food or liquids.

Preparation of the Oral Suspension: Prior to use of the oral suspension, ensure patients or caregivers receive training on proper dosing, preparation, and administration of PROMACTA for oral suspension.

Administer the oral suspension immediately after preparation. **Discard any suspension not administered within 30 minutes after preparation.**

Prepare the suspension with water only. NOTE: Do not use hot water to prepare the suspension.

For details on preparation and administration of the suspension, including the recommended duration of use of each oral dosing syringe, see **Instructions for Use**.

3 DOSAGE FORMS AND STRENGTHS

Tablets

- 12.5-mg tablets — round, biconvex, white, film-coated tablets debossed with GS MZ1 and 12.5 on one side. Each tablet, for oral administration, contains eltrombopag olamine, equivalent to 12.5 mg of eltrombopag free acid.
- 25-mg tablets — round, biconvex, orange, film-coated tablets debossed with GS NX3 and 25 on one side. Each tablet, for oral administration, contains eltrombopag olamine, equivalent to 25 mg of eltrombopag free acid.

- 50-mg tablets — round, biconvex, blue, film-coated tablets debossed with GS UFU and 50 on one side. Each tablet, for oral administration, contains eltrombopag olamine, equivalent to 50 mg of eltrombopag free acid.
- 75-mg tablets — round, biconvex, pink, film-coated tablets debossed with GS FFS and 75 on one side. Each tablet, for oral administration, contains eltrombopag olamine, equivalent to 75 mg of eltrombopag free acid.

For Oral Suspension

- 12.5-mg packet — contains a reddish-brown to yellow powder for reconstitution.
- 25-mg packet — contains a reddish-brown to yellow powder for reconstitution.

4 CONTRAINDICATIONS

None.

5 WARNINGS AND PRECAUTIONS

5.1 Hepatic Decompensation in Patients With Chronic Hepatitis C

In patients with chronic hepatitis C, PROMACTA in combination with interferon and ribavirin may increase the risk of hepatic decompensation. In two controlled clinical trials in patients with chronic hepatitis C and thrombocytopenia, ascites and encephalopathy occurred more frequently on the arm receiving treatment with PROMACTA plus antivirals (7%) than the placebo plus antivirals arm (4%). Patients with low albumin levels (less than 3.5 g/dL) or Model for End-Stage Liver Disease (MELD) score greater than or equal to 10 at baseline had a greater risk for hepatic decompensation on the arm receiving treatment with PROMACTA plus antivirals. Discontinue PROMACTA if antiviral therapy is discontinued.

5.2 Hepatotoxicity

PROMACTA may increase the risk of severe and potentially life-threatening hepatotoxicity [*see Adverse Reactions (6.1)*]. One patient (< 1%) with chronic ITP treated with PROMACTA in clinical trials experienced drug-induced liver injury. Eleven patients (1%) with chronic hepatitis C treated with PROMACTA in clinical trials experienced drug-induced liver injury.

Treatment of ITP, Chronic Hepatitis C-associated Thrombocytopenia, and Refractory Severe Aplastic Anemia

Measure serum ALT, AST, and bilirubin prior to initiation of PROMACTA, every 2 weeks during the dose adjustment phase, and monthly following establishment of a stable dose. PROMACTA inhibits UDP-glucuronosyltransferase (UGT)1A1 and organic anion-transporting polypeptide (OATP)1B1, which may lead to indirect hyperbilirubinemia. If bilirubin is elevated, perform fractionation. Evaluate abnormal serum liver tests with repeat testing within 3 to 5 days. If the abnormalities are confirmed, monitor serum liver tests weekly until resolved or stabilized. Discontinue PROMACTA if ALT levels increase to greater than or equal to 3 x ULN in patients with normal liver function or greater than or equal to 3 x baseline (or greater than 5 x ULN, whichever is the lower) in patients with pre-treatment elevations in transaminases and are:

- progressively increasing, or
- persistent for greater than or equal to 4 weeks, or
- accompanied by increased direct bilirubin, or
- accompanied by clinical symptoms of liver injury or evidence for hepatic decompensation.

If the potential benefit for reinitiating treatment with PROMACTA is considered to outweigh the risk for hepatotoxicity, then consider cautiously reintroducing PROMACTA and measure serum liver tests weekly during the dose adjustment phase. Hepatotoxicity may reoccur if PROMACTA is reinitiated. If liver test abnormalities persist, worsen, or recur, then permanently discontinue PROMACTA.

First-Line Treatment of Severe Aplastic Anemia

Measure ALT, AST, and bilirubin prior to initiation of PROMACTA, every other day while hospitalized for h-ATG therapy, and then every 2 weeks during treatment. During treatment, manage increases in ALT or AST levels as recommended in Table 6.

5.3 Increased Risk of Death and Progression of Myelodysplastic Syndromes to Acute Myeloid Leukemia

A randomized, double-blind, placebo-controlled, multicenter trial in patients with International Prognostic Scoring System (IPSS) intermediate-1, intermediate-2 or high risk MDS with thrombocytopenia, receiving azacitidine in combination with either PROMACTA (n = 179) or placebo (n = 177) was terminated due to lack of efficacy and safety reasons, including increased progression to acute myeloid leukemia (AML). Patients received PROMACTA or placebo at a starting dose of 200 mg once daily, up to a maximum of 300 mg once daily, in combination with azacitidine for at least six cycles. The incidence of death (overall survival) was 32% (57/179) in the PROMACTA arm versus 29% (51/177) in the placebo arm (HR [95% CI] = 1.42 [0.97, 2.08], showing an increased relative risk of death in this trial by 42% in the PROMACTA arm). The incidence of progression to AML was 12% (21/179) in the PROMACTA arm versus 6% (10/177) in the placebo arm (HR [95% CI] = 2.66 [1.31, 5.41], showing an increased relative risk of progression to AML in this trial by 166% in the PROMACTA arm).

5.4 Thrombotic/Thromboembolic Complications

Thrombotic/thromboembolic complications may result from increases in platelet counts with PROMACTA. Reported thrombotic/thromboembolic complications included both venous and arterial events and were observed at low and at normal platelet counts.

Consider the potential for an increased risk of thromboembolism when administering PROMACTA to patients with known risk factors for thromboembolism (e.g., Factor V Leiden, ATIII deficiency, antiphospholipid syndrome, chronic liver disease). To minimize the risk for thrombotic/thromboembolic complications, do not use PROMACTA in an attempt to normalize platelet counts. Follow the dose adjustment guidelines to achieve and maintain target platelet counts [*see Dosage and Administration (2.1, 2.2, 2.3)*].

In two controlled clinical trials in patients with chronic hepatitis C and thrombocytopenia, 3% (31/955) treated with PROMACTA experienced a thrombotic event compared with 1% (5/484) on placebo. The majority of events were of the portal venous system (1% in patients treated with PROMACTA versus less than 1% for placebo).

In a controlled trial in patients with chronic liver disease and thrombocytopenia not related to ITP undergoing elective invasive procedures (N = 292), the risk of thrombotic events was increased in patients treated with 75 mg of PROMACTA once daily. Seven thrombotic complications (six patients) were reported in the group that received PROMACTA and three thrombotic complications were reported in the placebo group (two patients). All of the thrombotic complications reported in the group that received PROMACTA were portal vein thrombosis (PVT). Symptoms of PVT included abdominal pain, nausea, vomiting, and diarrhea. Five of the six patients in the group that received PROMACTA experienced a thrombotic complication within 30 days of completing treatment with PROMACTA and at a platelet count above $200 \times 10^9/L$. The risk of portal venous thrombosis was increased in thrombocytopenic patients with chronic liver disease treated with 75 mg of PROMACTA once daily for 2 weeks in preparation for invasive procedures.

5.5 Cataracts

In the three controlled clinical trials in adults with chronic ITP, cataracts developed or worsened in 15 (7%) patients who received 50 mg of PROMACTA daily and 8 (7%) placebo-group patients. In the extension trial, cataracts developed or worsened in 11% of patients who underwent ocular examination prior to therapy with PROMACTA. In the two controlled clinical trials in patients with chronic hepatitis C and thrombocytopenia, cataracts developed or worsened in 8% of patients treated with PROMACTA and 5% of patients treated with placebo.

Cataracts were observed in toxicology studies of eltrombopag in rodents [see *Nonclinical Toxicology (13.2)*]. Perform a baseline ocular examination prior to administration of PROMACTA and, during therapy with PROMACTA, regularly monitor patients for signs and symptoms of cataracts.

6 ADVERSE REACTIONS

The following clinically significant adverse reactions associated with PROMACTA are described in other sections.

- Hepatic Decompensation in Patients with Chronic Hepatitis C [see *Warnings and Precautions (5.1)*]
- Hepatotoxicity [see *Warnings and Precautions (5.2)*]
- Increased Risk of Death and Progression of Myelodysplastic Syndromes to Acute Myeloid Leukemia [see *Warnings and Precautions (5.3)*]
- Thrombotic/Thromboembolic Complications [see *Warnings and Precautions (5.4)*]
- Cataracts [see *Warnings and Precautions (5.5)*]

6.1 Clinical Trials Experience

Because clinical trials are conducted under widely varying conditions, adverse reaction rates observed in the clinical trials of a drug cannot be directly compared with rates in the clinical trials of another drug and may not reflect the rates observed in practice.

Chronic Immune Thrombocytopenia: Adults: In clinical trials, hemorrhage was the most common serious adverse reaction and most hemorrhagic reactions followed discontinuation of PROMACTA. Other serious adverse reactions included thrombotic/thromboembolic complications [see *Warnings and Precautions (5.4)*]. The data described below reflect exposure of PROMACTA to patients with chronic ITP aged 18 to 85 years, of whom 66% were female, in three placebo-controlled trials and one open-label extension trial [see *Clinical Studies (14.1)*]. PROMACTA was administered to 330 patients for at least 6 months and 218 patients for at least 1 year.

Table 8 presents the most common adverse drug reactions (experienced by greater than or equal to 3% of patients receiving PROMACTA) from the three placebo-controlled trials, with a higher incidence in PROMACTA versus placebo.

Table 8. Adverse Reactions ($\geq 3\%$) From Three Placebo-controlled Trials in Adults with Chronic Immune Thrombocytopenia

Adverse Reaction	PROMACTA 50 mg n = 241 (%)	Placebo n = 128 (%)
Nausea	9	3
Diarrhea	9	7
Upper respiratory tract infection	7	6
Vomiting	6	< 1
Urinary tract infection ^a	5	4
Increased ALT	5	3
Myalgia	5	2
Oropharyngeal pain	4	3
Increased AST	4	2
Pharyngitis	4	2
Back pain	3	2
Influenza	3	2
Paresthesia	3	2
Rash	3	2

^a Includes PTs of Urinary tract infection, Cystitis, Urinary tract infection bacterial, and Bacteriuria.

In the three controlled clinical chronic ITP trials, alopecia, musculoskeletal pain, blood alkaline phosphatase increased, and dry mouth were the adverse reactions reported in 2% of patients treated with PROMACTA and in no patients who received placebo.

Among 302 patients with chronic ITP who received PROMACTA in the single-arm extension trial, the adverse reactions occurred in a pattern similar to that seen in the placebo-controlled trials. Table 9 presents the most common treatment-related adverse reactions (experienced by greater than or equal to 3% of patients receiving PROMACTA) from the extension trial.

Table 9. Treatment-related Adverse Reactions ($\geq 3\%$) From Extension Trial in Adults With Chronic Immune Thrombocytopenia

Adverse Reaction	PROMACTA 50 mg n = 302 (%)
Headache	10
ALT increased	5
AST increased	5
Cataract	5
Fatigue	5
Blood bilirubin increased	4
Nausea	4
Hyperbilirubinemia	3
Diarrhea	3

In the three controlled chronic ITP trials, serum liver test abnormalities (predominantly Grade 2 or less in severity) were reported in 11% and 7% of patients for PROMACTA and placebo, respectively. Four patients (1%) treated with PROMACTA and three patients in the placebo group (2%) discontinued treatment due to hepatobiliary laboratory abnormalities. Seventeen of the patients treated with PROMACTA in the controlled trials with hepatobiliary laboratory abnormalities were re-exposed to PROMACTA in the extension trial. Eight of these patients again experienced liver test abnormalities (less than or equal to Grade 3) resulting in

discontinuation of PROMACTA in one patient. In the extension chronic ITP trial, six additional patients had PROMACTA discontinued due to liver test abnormalities (less than or equal to Grade 3).

In the three controlled chronic ITP trials, cataracts developed or worsened in 7% of patients treated with PROMACTA and 7% of patients in the placebo group. All patients had documented, preexisting risk factors for cataractogenesis including corticosteroid use. In the extension trial, cataracts developed or worsened in 11% of patients who underwent ocular examination prior to therapy with PROMACTA. Seventy-two percent of patients had preexisting risk factors, including corticosteroid use.

The safety of PROMACTA was also assessed in all patients treated in 7 adult chronic ITP clinical trials (N = 763 PROMACTA-treated patients and 179 placebo-treated patients). Thromboembolic events were reported in 6% of PROMACTA-treated patients versus 0% of placebo-treated patients and thrombotic microangiopathy with acute renal failure was reported in < 1% of PROMACTA-treated patients versus 0% of placebo-treated patients.

In a placebo-controlled trial of PROMACTA in patients with chronic liver disease and thrombocytopenia not related to ITP, six patients treated with PROMACTA and one patient in the placebo group developed portal vein thromboses [see *Warnings and Precautions (5.4)*].

Pediatric Patients: The data described below reflect median exposure to PROMACTA of 91 days for 107 pediatric patients (aged 1 to 17 years) with chronic ITP, of whom 53% were female, across the randomized phase of two placebo-controlled trials.

Table 10 presents the most common adverse drug reactions (experienced by greater than or equal to 3% of pediatric patients 1 year and older receiving PROMACTA) across the two placebo-controlled trials, with a higher incidence for PROMACTA versus placebo.

Table 10. Adverse Reactions (≥ 3%) With a Higher Incidence for PROMACTA Versus Placebo From Two Placebo-controlled Trials in Pediatric Patients 1 Year and Older With Chronic Immune Thrombocytopenia

Adverse Reaction	PROMACTA n = 107 (%)	Placebo n = 50 (%)
Upper respiratory tract infection	17	6
Nasopharyngitis	12	4
Cough	9	0
Diarrhea	9	2
Pyrexia	9	8
Abdominal pain	8	4
Oropharyngeal pain	8	2
Toothache	6	0
ALT increased ^a	6	0
Rash	5	2
AST increased	4	0
Rhinorrhea	4	0

^a Includes adverse reactions or laboratory abnormalities > 3 x ULN.

In the two controlled clinical chronic ITP trials, cataracts developed or worsened in 2 (1%) patients treated with PROMACTA. Both patients had received chronic oral corticosteroids, a risk factor for cataractogenesis.

Chronic Hepatitis C-associated Thrombocytopenia: In the two placebo-controlled trials, 955 patients with chronic hepatitis C-associated thrombocytopenia received PROMACTA. Table 11 presents the most common adverse drug reactions (experienced by greater than or equal to 10% of patients receiving PROMACTA compared with placebo).

Table 11. Adverse Reactions ($\geq 10\%$ and Greater Than Placebo) From Two Placebo-controlled Trials in Adults With Chronic Hepatitis C

Adverse Reaction	PROMACTA + Peginterferon/Ribavirin n = 955 (%)	Placebo + Peginterferon/Ribavirin n = 484 (%)
Anemia	40	35
Pyrexia	30	24
Fatigue	28	23
Headache	21	20
Nausea	19	14
Diarrhea	19	11
Decreased appetite	18	14
Influenza-like illness	18	16
Insomnia ^a	16	15
Asthenia	16	13
Cough	15	12
Pruritus	15	13
Chills	14	9
Myalgia	12	10
Alopecia	10	6
Peripheral edema	10	5

^a Includes PTs of Insomnia, Initial insomnia, and Poor quality sleep.

Rash was reported in 9% and 7% of patients receiving PROMACTA and placebo, respectively.

In the two controlled clinical trials in patients with chronic hepatitis C, hyperbilirubinemia was reported in 8% of patients receiving PROMACTA compared with 3% for placebo. Total bilirubin greater than or equal to 1.5 x ULN was reported in 76% and 50% of patients receiving PROMACTA and placebo, respectively. ALT or AST greater than or equal to 3 x ULN was reported in 34% and 38% of patients for PROMACTA and placebo, respectively.

In the two controlled clinical trials in patients with chronic hepatitis C, cataracts developed or worsened in 8% of patients treated with PROMACTA and 5% of patients treated with placebo.

The safety of PROMACTA was also assessed in all patients treated with PROMACTA in the two controlled trials, including patients who initially received PROMACTA in the pre-antiviral treatment phase of the trial and were later randomized to the placebo arm (N = 1520 PROMACTA-treated patients). Hepatic failure was reported in 0.8% of PROMACTA-treated patients and 0.4% of placebo-treated patients.

Severe Aplastic Anemia:

First-Line Treatment of Severe Aplastic Anemia

The safety of PROMACTA was established based upon a single-arm trial of 153 patients with severe aplastic anemia who had not received prior definitive immunosuppressive therapy. In this trial, PROMACTA was administered in combination with horse antithymocyte globulin (h-ATG) and cyclosporine [*see Clinical Studies (14.3)*]. Among the 153 patients who were dosed in this trial, 92 patients were evaluable for safety of the concurrent use of PROMACTA, h-ATG, and cyclosporine at the recommended dose and schedule.

In this cohort, PROMACTA was administered at up to 150 mg once daily on Day 1 to Month 6 (D1-M6) in combination with h-ATG on Days 1 to 4 and cyclosporine for 6 months, followed by low dose of cyclosporine (maintenance dose) for an additional 18 months for patients who achieved a hematologic response at 6 months.

The median duration of exposure to PROMACTA in this cohort was 183 days with 70% of patients exposed for > 24 weeks.

Table 12 presents the most common adverse reactions (experienced by greater than or equal to 5% of patients) associated with PROMACTA in the D1-M6 cohort.

Table 12. Adverse Reactions ($\geq 5\%$) From One Open-label Trial in First-line Treatment of Patients With Severe Aplastic Anemia

Adverse Reaction	PROMACTA n = 92 (%)
ALT increased	29
AST increased	17
Blood bilirubin increased	17
Rash	8
Skin discoloration including hyperpigmentation	5

In the PROMACTA D1-M6 cohort, ALT increased (29%), AST increased (17%), and blood bilirubin increased (17%) were reported more frequently than in patients with refractory severe aplastic anemia (see Table 13).

New or worsening liver function laboratory abnormalities (CTCAE Grade 3 and Grade 4) in the Promacta D1-M6 cohort were 15% and 2% for AST, 26% and 4% for ALT, and 12% and 1% for bilirubin, respectively.

In this single-arm open-label clinical trial, ALT or AST > 3 x ULN with total bilirubin > 1.5 x ULN and ALT or AST > 3 x ULN with total bilirubin > 2 x ULN were reported in 44% and 32% of patients, respectively, in the PROMACTA D1-M6 cohort.

Pediatric Patients

A total of 34 pediatric patients (2 patients 2 to 5 years of age, 12 patients 6 to 11 years of age, and 20 patients 12 to 16 years of age) were enrolled in this single-arm trial of which 26 pediatric patients were enrolled in the PROMACTA D1-M6 cohort. In this cohort, the most frequent serious adverse reactions (experienced by $\geq 10\%$ of patients) were upper respiratory tract infection (12% in patients age 2 to 16 years compared to 5% in patients 17 years of age and older, respectively) and rash (12% compared to 2%). The most common adverse reactions (experienced by $\geq 10\%$ of patients) associated with PROMACTA were ALT increased (23% in patients age 2 to 16 years compared to 32% in patients 17 years of age and older, respectively), blood bilirubin increased (12% compared to 20%), AST increased (12% compared to 20%), and rash (12% compared to 6%).

Cytogenetic Abnormalities

In this trial, patients had bone marrow aspirates evaluated for cytogenetic abnormalities. Seven patients in the PROMACTA D1-M6 cohort had a new cytogenetic abnormality reported of which 4 had the loss of chromosome 7; these 4 occurred within 6.1 months. Across all cohorts, clonal cytogenetic evolution occurred in 15 out of 153 (10%) patients. Of the 15 patients who experienced a cytogenetic abnormality: 7 patients had the loss of chromosome 7, 6 of which occurred within 6.1 months; 4 patients had chromosomal aberrations which were of unclear significance; 3 patients had a deletion of chromosome 13; and 1 patient had a follow-up bone marrow assessment at 5 years with features of dysplasia with hypercellularity concerning for potential development of MDS. It is unclear whether these findings occurred due to the underlying disease, the immunosuppressive therapy, and/or treatment with PROMACTA.

Refractory Severe Aplastic Anemia

In the single-arm, open-label trial, 43 patients with refractory severe aplastic anemia received PROMACTA. Eleven patients (26%) were treated for greater than 6 months and 7 patients (16%) were treated for greater than 1 year. The most common adverse reactions (greater than or equal to 20%) were nausea, fatigue, cough, diarrhea, and headache.

Table 13. Adverse Reactions ($\geq 10\%$) From One Open-label Trial in Adults With Refractory Severe Aplastic Anemia

Adverse Reaction	PROMACTA n = 43 (%)
Nausea	33
Fatigue	28
Cough	23
Diarrhea	21
Headache	21
Pain in extremity	19
Pyrexia	14
Dizziness	14
Oropharyngeal pain	14
Abdominal pain	12
Muscle spasms	12
Transaminases increased	12
Arthralgia	12
Rhinorrhea	12

Rash and hyperbilirubinemia were reported in 7% of patients; cataract was reported in 2% of patients.

In this trial, concurrent ALT or AST greater than 3 x ULN with total bilirubin greater than 1.5 x ULN were reported in 5% of patients. Total bilirubin greater than 1.5 x ULN occurred in 14% of patients.

In this trial, patients had bone marrow aspirates evaluated for cytogenetic abnormalities. Eight patients had a new cytogenetic abnormality reported on therapy, including 5 patients who had complex changes in chromosome 7.

6.2 Postmarketing Experience

The following adverse reactions have been identified during post approval use of PROMACTA. Because these reactions are reported voluntarily from a population of uncertain size, it is not always possible to reliably estimate the frequency or establish a causal relationship to drug exposure.

Skin and Subcutaneous Tissue Disorders: Skin discoloration including hyperpigmentation and skin yellowing.

7 DRUG INTERACTIONS

7.1 Polyvalent Cations (Chelation)

Eltrombopag chelates polyvalent cations (such as iron, calcium, aluminum, magnesium, selenium, and zinc) in foods, mineral supplements, and antacids.

Take PROMACTA at least 2 hours before or 4 hours after any medications or products containing polyvalent cations such as antacids, dairy products, and mineral supplements to avoid significant reduction in absorption of PROMACTA due to chelation [see *Dosage and Administration (2.4)*, *Clinical Pharmacology (12.3)*].

7.2 Transporters

Use caution when concomitantly administering PROMACTA and drugs that are substrates of OATP1B1 (e.g., atorvastatin, bosentan, ezetimibe, fluvastatin, glyburide, olmesartan, pitavastatin, pravastatin, rosuvastatin, repaglinide, rifampin, simvastatin acid, SN-38 [active metabolite of irinotecan], valsartan) or breast cancer resistance protein (BCRP) (e.g., imatinib, irinotecan, lapatinib, methotrexate, mitoxantrone, rosuvastatin, sulfasalazine, topotecan). Monitor patients closely for signs and symptoms of excessive exposure to the drugs

that are substrates of OATP1B1 or BCRP and consider reduction of the dose of these drugs, if appropriate. In clinical trials with PROMACTA, a dose reduction of rosuvastatin by 50% was recommended.

7.3 Protease Inhibitors

HIV Protease Inhibitors: No dose adjustment is recommended when PROMACTA is coadministered with lopinavir/ritonavir (LPV/RTV). Drug interactions with other HIV protease inhibitors have not been evaluated.

Hepatitis C Virus Protease Inhibitors: No dose adjustments are recommended when PROMACTA is coadministered with boceprevir or telaprevir. Drug interactions with other hepatitis c virus (HCV) protease inhibitors have not been evaluated.

7.4 Peginterferon alfa-2a/b Therapy

No dose adjustments are recommended when PROMACTA is coadministered with peginterferon alfa-2a (PEGASYS[®]) or -2b (PEGINTRON[®]).

8 USE IN SPECIFIC POPULATIONS

8.1 Pregnancy

Risk Summary

Available data from a small number of published case reports and postmarketing experience with PROMACTA use in pregnant women are insufficient to assess any drug-associated risks for major birth defects, miscarriage, or adverse maternal or fetal outcomes. In animal reproduction and developmental toxicity studies, oral administration of eltrombopag to pregnant rats during organogenesis resulted in embryoletality and reduced fetal weights at maternally toxic doses. These effects were observed at doses resulting in exposures that were six times the human clinical exposure based on area under the curve (AUC) in patients with chronic ITP at 75 mg/day, and three times the AUC in patients with chronic hepatitis C at 100 mg/day (*see Data*).

The estimated background risk of major birth defects and miscarriage for the indicated population is unknown. All pregnancies have a background risk of birth defect, loss, or other adverse outcomes. In the U.S. general population, the estimated background risk of major birth defects and of miscarriage in clinically recognized pregnancies is 2%-4% and 15%-20%, respectively.

Data

Animal Data

In an early embryonic development study, female rats received oral eltrombopag at doses of 10, 20, or 60 mg/kg/day (0.8, 2, and 6 times, respectively, the human clinical exposure based on AUC in patients with ITP at 75 mg/day and 0.3, 1, and 3 times, respectively, the human clinical exposure based on AUC in patients with chronic hepatitis C at 100 mg/day). Increased pre- and post-implantation loss and reduced fetal weight were observed at the highest dose which also caused maternal toxicity.

In an embryo-fetal development study eltrombopag was administered orally to pregnant rats during the period of organogenesis at doses of 10, 20, or 60 mg/kg/day (0.8, 2, and 6 times, respectively, the human clinical exposure based on AUC in patients with ITP at 75 mg/day and 0.3, 1, and 3 times, respectively, the human clinical exposure based on AUC in patients with chronic hepatitis C at 100 mg/day). Decreased fetal weights (6% to 7%) and a slight increase in the presence of cervical ribs were observed at the highest dose which also caused maternal toxicity. However, no evidence of major structural malformations was observed.

In an embryo-fetal development study eltrombopag was administered orally to pregnant rabbits during the period of organogenesis at doses of 30, 80, or 150 mg/kg/day (0.04, 0.3, and 0.5 times, respectively, the human clinical exposure based on AUC in patients with ITP at 75 mg/day and 0.02, 0.1, and 0.3 times, respectively, the human clinical exposure based on AUC in patients with chronic hepatitis C at 100 mg/day). No evidence of fetotoxicity, embryoletality, or teratogenicity was observed.

In a pre- and post-natal developmental toxicity study in pregnant rats (F0), oral eltrombopag was administered from gestation Day 6 through lactation Day 20. No adverse effects on maternal reproductive function or on the development of the offspring (F1) were observed at doses up to 20 mg/kg/day (2 times the human clinical exposure based on AUC in patients with ITP at 75 mg/day and similar to the human clinical exposure based on AUC in patients with chronic hepatitis C at 100 mg/day). Eltrombopag was detected in the plasma of offspring (F1). The plasma concentrations in pups increased with dose following administration of drug to the F0 dams.

8.2 Lactation

Risk Summary

There are no data regarding the presence of eltrombopag or its metabolites in human milk, the effects on the breastfed child, or the effects on milk production. However, eltrombopag was detected in the pups of lactating rats 10 days postpartum suggesting the potential for transfer during lactation. Due to the potential for serious adverse reactions in a breastfed child from PROMACTA, breastfeeding is not recommended during treatment.

8.3 Females and Males of Reproductive Potential

Contraception

Based on animal reproduction studies, PROMACTA can cause fetal harm when administered to a pregnant woman. Sexually-active females of reproductive potential should use effective contraception (methods that result in less than 1% pregnancy rates) when using PROMACTA during treatment and for at least 7 days after stopping treatment with PROMACTA.

8.4 Pediatric Use

The safety and efficacy of PROMACTA have been established in pediatric patients 1 year and older with chronic ITP and in pediatric patients 2 years and older with IST-naïve severe aplastic anemia (in combination with h-ATG and cyclosporine). Safety and efficacy in pediatric patients below the age of 1 year with ITP have not been established. Safety and efficacy in pediatric patients with thrombocytopenia associated with chronic hepatitis C and refractory severe aplastic anemia have not been established.

The safety and efficacy of PROMACTA in pediatric patients 1 year and older with chronic ITP were evaluated in two double-blind, placebo-controlled trials [see *Adverse Reactions (6.1)*, *Clinical Studies (14.1)*]. The pharmacokinetics of eltrombopag have been evaluated in 168 pediatric patients 1 year and older with ITP dosed once daily [see *Clinical Pharmacology (12.3)*]. See *Dosage and Administration (2.1)* for dosing recommendations for pediatric patients 1 year and older.

The safety and efficacy of PROMACTA in combination with h-ATG and cyclosporine for the first-line treatment of severe aplastic anemia in pediatric patients 2 years and older were evaluated in a single-arm, open-label trial [see *Adverse Reactions (6.1)*, *Clinical Studies (14.3)*]. A total of 26 pediatric patients (ages 2 to < 17 years) were evaluated; 12 children (aged 2 to < 12 years) and 14 adolescents (aged 12 to < 17). See *Dosage and Administration (2.3)* for dosing recommendations for pediatric patients 2 years and older. The safety and efficacy of PROMACTA in combination with h-ATG and cyclosporine in pediatric patients younger than 2 years for the first-line treatment of severe aplastic anemia have not yet been established. In patients 2 to 16 years of age, 69% of patients experienced serious adverse events compared to 42% in patients 17 years and older. Among the 12 patients who were 2 to 11 years of age in the PROMACTA D1-M6 cohort and reached the 6-month assessment or withdrew earlier, the complete response rate at Month 6 was 8% versus 46% in patients age 12 to 16 years and 50% in patients 17 years of age and older.

8.5 Geriatric Use

Of the 106 patients in two randomized clinical trials of PROMACTA 50 mg in chronic ITP, 22% were 65 years of age and over, while 9% were 75 years of age and over. Of the 1439 patients in two randomized clinical trials of PROMACTA in patients with chronic hepatitis C and thrombocytopenia, 7% were 65 years of age and over, while < 1% were 75 years of age and over. Of the 196 patients who received PROMACTA for the treatment of

severe aplastic anemia, 18% were 65 years of age and over, while 3% were 75 years of age and over. No overall differences in safety or effectiveness were observed between these patients and younger patients.

8.6 Hepatic Impairment

Patients With Chronic ITP and Severe Aplastic Anemia

Reduce the initial dose of PROMACTA in patients with chronic ITP (adult and pediatric patients 6 years and older only) or refractory severe aplastic anemia who also have hepatic impairment (Child-Pugh Class A, B, C) [see *Dosage and Administration (2.1, 2.3)*, *Warnings and Precautions (5.2)*, *Clinical Pharmacology (12.3)*].

In a clinical trial in patients with severe aplastic anemia who had not received prior definitive immunosuppressive therapy, patients with baseline ALT or AST > 5 x ULN were ineligible to participate. If a patient with hepatic impairment (Child-Pugh Class A, B, C) initiates therapy with PROMACTA for the first-line treatment of severe aplastic anemia, reduce the initial dose [see *Dosage and Administration (2.3)*, *Warnings and Precautions (5.2)*, *Clinical Pharmacology (12.3)*].

Patients With Chronic Hepatitis C

No dosage adjustment is recommended in patients with chronic hepatitis C and hepatic impairment [see *Clinical Pharmacology (12.3)*].

8.7 Ethnicity

Reduce the initial dose of PROMACTA for patients of Asian ancestry (such as Chinese, Japanese, Taiwanese, or Korean) with ITP (adult and pediatric patients 6 years and older only) or severe aplastic anemia [see *Dosage and Administration (2.1, 2.3)*, *Clinical Pharmacology (12.3)*]. No reduction in the initial dose of PROMACTA is recommended in patients of Asian ethnicity with chronic hepatitis C [see *Clinical Pharmacology (12.3)*].

10 OVERDOSAGE

In the event of overdose, platelet counts may increase excessively and result in thrombotic/thromboembolic complications.

In one report, a subject who ingested 5000 mg of PROMACTA had a platelet count increase to a maximum of $929 \times 10^9/L$ at 13 days following the ingestion. The patient also experienced rash, bradycardia, ALT/AST elevations, and fatigue. The patient was treated with gastric lavage, oral lactulose, intravenous fluids, omeprazole, atropine, furosemide, calcium, dexamethasone, and plasmapheresis; however, the abnormal platelet count and liver test abnormalities persisted for 3 weeks. After 2 months' follow-up, all events had resolved without sequelae.

In case of an overdose, consider oral administration of a metal cation-containing preparation, such as calcium, aluminum, or magnesium preparations to chelate eltrombopag and thus limit absorption. Closely monitor platelet counts. Reinitiate treatment with PROMACTA in accordance with dosing and administration recommendations [see *Dosage and Administration (2.1, 2.2)*].

11 DESCRIPTION

PROMACTA (eltrombopag) tablets contain eltrombopag olamine, a small molecule thrombopoietin (TPO) receptor agonist for oral administration. Eltrombopag interacts with the transmembrane domain of the TPO receptor (also known as cMpl) leading to increased platelet production.

Eltrombopag olamine is a biphenyl hydrazone. The chemical name for eltrombopag olamine is 3'-{(2Z)-2-[1-(3,4-dimethylphenyl)-3-methyl-5-oxo-1,5-dihydro-4H-pyrazol-4-ylidene]hydrazino}-2'-hydroxy-3-biphenylcarboxylic acid - 2-aminoethanol (1:2). It has the molecular formula $C_{25}H_{22}N_4O_4 \cdot 2(C_2H_7NO)$. The molecular weight is 564.65 g/mol for eltrombopag olamine and 442.5 g/mol for eltrombopag free acid. Eltrombopag olamine has the following structural formula:

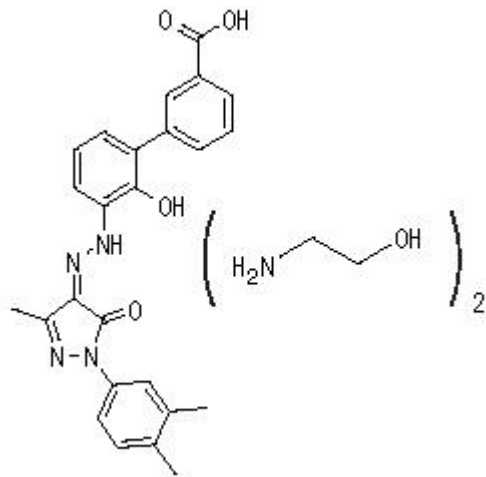

Eltrombopag olamine is practically insoluble in aqueous buffer across a pH range of 1 to 7.4, and is sparingly soluble in water.

PROMACTA (eltrombopag) tablets contain eltrombopag olamine in the amount equivalent to 12.5 mg, 25 mg, 50 mg, or 75 mg of eltrombopag free acid. The inactive ingredients of PROMACTA tablets are:

Tablet Core: magnesium stearate, mannitol, microcrystalline cellulose, povidone, and sodium starch glycolate.

Coating:

FD&C Blue No. 2 aluminum lake (50-mg tablet), FD&C Yellow No. 6 aluminum lake (25-mg tablet), hypromellose, Iron Oxide Black and Iron Oxide Red (75-mg tablet), polyethylene glycol 400, polysorbate 80 (12.5-mg tablet), or titanium dioxide.

PROMACTA (eltrombopag) for oral suspension packets contain a reddish-brown to yellow powder which produces a reddish-brown suspension when reconstituted with water. Each packet delivers eltrombopag olamine equivalent to 12.5 mg or 25 mg of eltrombopag free acid. The inactive ingredients of PROMACTA for oral suspension are mannitol, sucralose, and xanthan gum.

12 CLINICAL PHARMACOLOGY

12.1 Mechanism of Action

Eltrombopag is an orally bioavailable, small-molecule TPO-receptor agonist that interacts with the transmembrane domain of the human TPO-receptor and initiates signaling cascades that induce proliferation and differentiation from bone marrow progenitor cells.

12.2 Pharmacodynamics

In clinical trials, treatment with PROMACTA resulted in dose-dependent increases in platelet counts following repeated (daily) dosing. The increase in platelet counts reached a maximum approximately two weeks after the initiation of dosing, and returned to baseline within approximately two weeks after the last dose of PROMACTA.

Cardiac Electrophysiology

At doses up to 150 mg (the maximum recommended dose) daily for 5 days, PROMACTA did not prolong the QT/QTc interval to any relevant extent.

12.3 Pharmacokinetics

Eltrombopag demonstrated a dose-proportional increase in exposure between doses of 50 to 150 mg/day in healthy adult subjects. Eltrombopag AUC was approximately 1.7 fold higher in patients with chronic ITP and approximately 2.8-fold higher in patients with HCV compared to healthy subjects. Steady-state was achieved

after approximately 1 week of once daily treatment, with geometric mean accumulation ratio of 1.56 (90% confidence interval 1.20, 1.63) at 75 mg/day. Eltrombopag AUC was approximately 3.2 fold higher in patients with definitive immunosuppressive therapy-naïve severe aplastic anemia compared to healthy subjects suggesting higher relative exposure compared to healthy subjects or patients with ITP and similar exposure compared to patients with chronic hepatitis C. Eltrombopag for oral suspension delivered 22% higher plasma AUC_{0-INF} than the tablet formulation.

Absorption

Eltrombopag is absorbed with a peak concentration occurring 2 to 6 hours after oral administration. Oral absorption of drug-related material following administration of a single 75-mg solution dose was estimated to be at least 52%.

Effect of Food

A standard high-fat breakfast (876 calories, 52 g fat, 71 g carbohydrate, 34 g protein, and 427 mg calcium) significantly decreased plasma eltrombopag AUC_{0-INF} by approximately 59% and C_{max} by 65% and delayed T_{max} by 1 hour. The decrease in exposure is primarily due to the high calcium content.

A meal low in calcium (≤ 50 mg calcium) did not significantly impact plasma eltrombopag exposure, regardless of calorie and fat content.

The effect of administration of a single 25-mg dose of eltrombopag for oral suspension with a high-calcium, moderate-fat, moderate calorie meal on AUC_{0-INF} and C_{max} in healthy adult subjects is presented in Table 14.

Table 14. Effect on Plasma Eltrombopag Pharmacokinetic Parameters After Administration of a Single 25-mg Dose of Eltrombopag for Oral Suspension with a High Calcium Meal^a in Healthy Adult Subjects

Timing of Eltrombopag for Oral Suspension Dose	Mean (90% CI) Reduction in Plasma Eltrombopag AUC _{0-INF}	Mean (90% CI) Reduction in Plasma Eltrombopag C _{max}
With a high-calcium, moderate-fat, moderate-calorie meal	75% (71%, 88%)	79% (76%, 82%)
2 hours after the high-calcium, moderate-fat, moderate-calorie meal	47% (40%, 53%)	48% (40%, 54%)
2 hours before the high-calcium, moderate-fat, moderate-calorie meal	20% (9%, 29%)	14% (2%, 25%)

^a 372 calories, 9 g fat, and 448 mg calcium.

Distribution

The concentration of eltrombopag in blood cells is approximately 50% to 79% of plasma concentrations based on a radiolabel study. *In vitro* studies suggest that eltrombopag is highly bound to human plasma proteins (greater than 99%). Eltrombopag is a substrate of BCRP, but is not a substrate for P-glycoprotein (P-gp) or OATP1B1.

Elimination

The plasma elimination half-life of eltrombopag is approximately 21 to 32 hours in healthy subjects and 26 to 35 hours in patients with ITP.

Metabolism: Absorbed eltrombopag is extensively metabolized, predominantly through pathways including cleavage, oxidation, and conjugation with glucuronic acid, glutathione, or cysteine. *In vitro* studies suggest that CYP1A2 and CYP2C8 are responsible for the oxidative metabolism of eltrombopag. UGT1A1 and UGT1A3 are responsible for the glucuronidation of eltrombopag.

Excretion: The predominant route of eltrombopag excretion is via feces (59%), and 31% of the dose is found in the urine. Unchanged eltrombopag in feces accounts for approximately 20% of the dose; unchanged eltrombopag is not detectable in urine.

Specific Populations

Ethnicity

Eltrombopag concentrations in Asian (i.e., Japanese, Chinese, Taiwanese, Korean) patients with ITP or chronic hepatitis C, were 50% to 55% higher compared with non-Asian subjects [*see Dosage and Administration (2.1, 2.3)*].

Eltrombopag exposure in healthy African-American subjects was approximately 40% higher than that observed in Caucasian subjects in one clinical pharmacology trial and similar in three other clinical pharmacology trials. The effect of African-American ethnicity on exposure and related safety and efficacy of eltrombopag has not been established.

Hepatic Impairment

Following a single dose of PROMACTA (50 mg), plasma eltrombopag AUC_{0-12h} was 41% higher in patients with mild hepatic impairment (Child-Pugh Class A) compared with subjects with normal hepatic function. Plasma eltrombopag AUC_{0-12h} was approximately 2-fold higher in patients with moderate (Child-Pugh Class B) and severe hepatic impairment (Child-Pugh Class C) compared with subjects with normal hepatic function. The half-life of eltrombopag was prolonged 2-fold in these patients. This clinical trial did not evaluate protein-binding effects.

Chronic Liver Disease

Following repeat doses of eltrombopag in patients with thrombocytopenia and with chronic liver disease, mild hepatic impairment resulted in an 87% to 110% higher plasma eltrombopag $AUC_{(0-\tau)}$ and moderate hepatic impairment resulted in approximately 141% to 240% higher plasma eltrombopag $AUC_{(0-\tau)}$ values compared with patients with normal hepatic function. The half-life of eltrombopag was prolonged 3-fold in patients with mild hepatic impairment and 4-fold in patients with moderate hepatic impairment. This clinical trial did not evaluate protein-binding effects.

Chronic Hepatitis C

Patients with chronic hepatitis C treated with PROMACTA had higher plasma $AUC_{(0-\tau)}$ values as compared with healthy subjects, and $AUC_{(0-\tau)}$ increased with increasing Child-Pugh score. Patients with chronic hepatitis C and mild hepatic impairment had approximately 100% to 144% higher plasma $AUC_{(0-\tau)}$ compared with healthy subjects. This clinical trial did not evaluate protein-binding effects.

Renal Impairment

Following a single dose of PROMACTA (50 mg), the average total plasma eltrombopag AUC_{0-12h} was 32% to 36% lower in subjects with mild (estimated creatinine clearance (CLCr) by Cockcroft - Gault equation: 50 to 80 mL/min), to moderate (CLCr of 30 to 49 mL/min) renal impairment and 60% lower in subjects with severe (CLCr less than 30 mL/min) renal impairment compared with healthy subjects. The effect of renal impairment on unbound (active) eltrombopag exposure has not been assessed.

Pediatric Patients

The pharmacokinetics of eltrombopag have been evaluated in 168 pediatric patients 1 year and older with ITP dosed once daily in two trials. Plasma eltrombopag apparent clearance following oral administration (CL/F) increased with increasing body weight. Asian pediatric patients with ITP had approximately 43% higher plasma eltrombopag $AUC_{(0-\tau)}$ values as compared with non-Asian patients.

Plasma eltrombopag $AUC_{(0-\tau)}$ and C_{max} in pediatric patients aged 12 to 17 years was similar to that observed in adults. The pharmacokinetic parameters of eltrombopag in pediatric patients with ITP are shown in Table 15.

Table 15. Geometric Mean (95% CI) Steady-state Plasma Eltrombopag Pharmacokinetic Parameters^a in Patients With ITP (Normalized to a Once-daily 50-mg Dose)

Age	C_{max}^b (mcg/mL)	$AUC_{(0-\tau)}^b$ (mcg·hr/mL)
Adults (n = 108)	7.03 (6.44, 7.68)	101 (91.4, 113)
12 to 17 years (n = 62)	6.80 (6.17, 7.50)	103 (91.1, 116)
6 to 11 years (n = 68)	10.3 (9.42, 11.2)	153 (137, 170)
1 to 5 years (n = 38)	11.6 (10.4, 12.9)	162 (139, 187)

^a PK parameters presented as geometric mean (95% CI).

^b Based on population PK post-hoc estimates.

Drug Interaction Studies

Clinical Studies

Effect of Drugs on Eltrombopag

Effect of Polyvalent Cation-containing Antacids on Eltrombopag:

The coadministration of a single dose of PROMACTA (75 mg) with a polyvalent cation-containing antacid (1,524 mg aluminum hydroxide, 1,425 mg magnesium carbonate, and sodium alginate) decreased plasma eltrombopag AUC_{0-INF} and C_{max} by approximately 70%. The contribution of sodium alginate to this interaction is not known.

Effect of HIV Protease Inhibitors on Eltrombopag:

The coadministration of repeat-dose lopinavir 400 mg/ritonavir 100 mg (twice daily) with a single dose of PROMACTA (100 mg) decreased plasma eltrombopag AUC_{0-INF} by 17%.

Effect of HCV Protease Inhibitors on Eltrombopag:

The coadministration of repeat-dose telaprevir (750 mg every 8 hours) or boceprevir (800 mg every 8 hours) with a single dose of PROMACTA (200 mg) to healthy adult subjects in a clinical trial did not alter plasma eltrombopag AUC_{0-INF} or C_{max} to a significant extent.

Effect of Cyclosporine on Eltrombopag:

The coadministration of a single dose of PROMACTA (50 mg) with a single dose of an OATP and BCRP inhibitor cyclosporine (200 mg or 600 mg) decreased plasma eltrombopag AUC_{0-INF} by 18% to 24% and C_{max} by 25% to 39%.

Effect of Pegylated Interferon alfa-2a + Ribavirin and Pegylated Interferon alfa-2b + Ribavirin on Eltrombopag:

The presence of pegylated interferon alfa + ribavirin therapy did not significantly affect the clearance of eltrombopag.

Effect of Eltrombopag on Other Drugs

Effect of Eltrombopag on Cytochrome P450 Enzymes Substrates:

The coadministration of multiple doses of PROMACTA (75 mg once daily for 7 days) did not result in the inhibition or induction of the metabolism of a combination of probe substrates for CYP1A2 (caffeine), CYP2C19 (omeprazole), CYP2C9 (flurbiprofen), or CYP3A4 (midazolam) in humans.

Effect of Eltrombopag on Rosuvastatin:

The coadministration of multiple doses of PROMACTA (75 mg once daily for 5 days) with a single dose of rosuvastatin (OATP1B1 and BCRP substrate; 10 mg) increased plasma rosuvastatin AUC_{0-INF} by 55% and C_{max} by 103%.

Effect of Eltrombopag on HCV Protease Inhibitors:

The coadministration of repeat-dose telaprevir (750 mg every 8 hours) or boceprevir (800 mg every 8 hours) with a single dose of PROMACTA (200 mg) to healthy adult subjects in a clinical trial did not alter plasma telaprevir or boceprevir AUC_{0-INF} or C_{max} to a significant extent.

In vitro Studies

Eltrombopag Effect on Metabolic Enzymes

Eltrombopag has demonstrated the potential to inhibit CYP2C8, CYP2C9, UGT1A1, UGT1A3, UGT1A4, UGT1A6, UGT1A9, UGT2B7, and UGT2B15.

Eltrombopag Effect on Transporters

Eltrombopag has demonstrated the potential to inhibit OATP1B1 and BCRP.

13 NONCLINICAL TOXICOLOGY

13.1 Carcinogenesis, Mutagenesis, Impairment of Fertility

Eltrombopag does not stimulate platelet production in rats, mice, or dogs because of unique TPO receptor specificity. Data from these animals do not fully model effects in humans.

Eltrombopag was not carcinogenic in mice at doses up to 75 mg/kg/day or in rats at doses up to 40 mg/kg/day (exposures up to 4 times the human clinical exposure based on AUC in patients with ITP at 75 mg/day and 2 times the human clinical exposure based on AUC in patients with chronic hepatitis C at 100 mg/day).

Eltrombopag was not mutagenic or clastogenic in a bacterial mutation assay or in two *in vivo* assays in rats (micronucleus and unscheduled DNA synthesis, 10 times the human clinical exposure based on C_{max} in patients with ITP at 75 mg/day and 7 times the human clinical exposure based on C_{max} in patients with chronic hepatitis C at 100 mg/day). In the *in vitro* mouse lymphoma assay, eltrombopag was marginally positive (less than 3-fold increase in mutation frequency).

Eltrombopag did not affect female fertility in rats at doses up to 20 mg/kg/day (2 times the human clinical exposure based on AUC in patients with ITP at 75 mg/day and similar to the human clinical exposure based on AUC in patients with chronic hepatitis C at 100 mg/day). Eltrombopag did not affect male fertility in rats at doses up to 40 mg/kg/day, the highest dose tested (3 times the human clinical exposure based on AUC in patients with ITP at 75 mg/day and 2 times the human clinical exposure based on AUC in patients with chronic hepatitis C at 100 mg/day).

13.2 Animal Pharmacology and/or Toxicology

Treatment-related cataracts were detected in rodents in a dose- and time-dependent manner. At greater than or equal to 6 times the human clinical exposure based on AUC in patients with ITP at 75 mg/day and 3 times the human clinical exposure based on AUC in patients with chronic hepatitis C at 100 mg/day, cataracts were observed in mice after 6 weeks and in rats after 28 weeks of dosing. At greater than or equal to 4 times the human clinical exposure based on AUC in patients with ITP at 75 mg/day and 2 times the human clinical exposure based on AUC in patients with chronic hepatitis C at 100 mg/day, cataracts were observed in mice after 13 weeks and in rats after 39 weeks of dosing [*see Warnings and Precautions (5.5)*].

Renal tubular toxicity was observed in studies up to 14 days in duration in mice and rats at exposures that were generally associated with morbidity and mortality. Tubular toxicity was also observed in a 2-year oral carcinogenicity study in mice at doses of 25, 75, and 150 mg/kg/day. The exposure at the lowest dose was

1.2 times the human clinical exposure based on AUC in patients with ITP at 75 mg/day and 0.6 times the human clinical exposure based on AUC in patients with chronic hepatitis C at 100 mg/day. No similar effects were observed in mice after 13 weeks at exposures greater than those associated with renal changes in the 2-year study, suggesting that this effect is both dose- and time-dependent.

14 CLINICAL STUDIES

14.1 Chronic ITP

Adults: The efficacy and safety of PROMACTA in adult patients with chronic ITP were evaluated in three randomized, double-blind, placebo-controlled trials and in an open-label extension trial.

In Study TRA100773B and Study TRA100773A (referred to as Study 773B and Study 773A, respectively [NCT00102739]), patients who had completed at least one prior ITP therapy and who had a platelet count less than $30 \times 10^9/L$ were randomized to receive either PROMACTA or placebo daily for up to 6 weeks, followed by 6 weeks off therapy. During the trials, PROMACTA or placebo was discontinued if the platelet count exceeded $200 \times 10^9/L$.

The median age of the patients was 50 years and 60% were female. Approximately 70% of the patients had received at least 2 prior ITP therapies (predominantly corticosteroids, immunoglobulins, rituximab, cytotoxic therapies, danazol, and azathioprine) and 40% of the patients had undergone splenectomy. The median baseline platelet counts (approximately $18 \times 10^9/L$) were similar among all treatment groups.

Study 773B randomized 114 patients (2:1) to PROMACTA 50 mg or placebo. Study 773A randomized 117 patients (1:1:1:1) among placebo or 1 of 3 dose regimens of PROMACTA, 30 mg, 50 mg, or 75 mg each administered daily.

The efficacy of PROMACTA in this trial was evaluated by response rate, defined as a shift from a baseline platelet count of less than $30 \times 10^9/L$ to greater than or equal to $50 \times 10^9/L$ at any time during the treatment period (Table 16).

Table 16. Studies 773B and 773A: Platelet Count Response ($\geq 50 \times 10^9/L$) Rates in Adults With Chronic Immune Thrombocytopenia

Study	PROMACTA 50 mg Daily	Placebo
773B	43/73 (59%) ^a	6/37 (16%)
773A	19/27 (70%) ^a	3/27 (11%)

^a p -value < 0.001 for PROMACTA versus placebo.

The platelet count response to PROMACTA was similar among patients who had or had not undergone splenectomy. In general, increases in platelet counts were detected 1 week following initiation of PROMACTA and the maximum response was observed after 2 weeks of therapy. In the placebo and 50-mg-dose groups of PROMACTA, the trial drug was discontinued due to an increase in platelet counts to greater than $200 \times 10^9/L$ in 3% and 27% of the patients, respectively. The median duration of treatment with the 50-mg dose of PROMACTA was 43 days in Study 773B and 42 days in Study 773A.

Of 7 patients who underwent hemostatic challenges, additional ITP medications were required in 3 of 3 placebo group patients and 0 of 4 patients treated with PROMACTA. Surgical procedures accounted for most of the hemostatic challenges. Hemorrhage requiring transfusion occurred in one placebo group patient and no patients treated with PROMACTA.

In the RAISE study (NCT00370331), 197 patients were randomized (2:1) to receive either PROMACTA 50 mg once daily ($n = 135$) or placebo ($n = 62$) for 6 months, during which time the dose of PROMACTA could be adjusted based on individual platelet counts. Patients were allowed to taper or discontinue concomitant ITP medications after being treated with PROMACTA for 6 weeks. Patients were permitted to receive rescue treatments at any time during the trial as clinically indicated.

The median ages of the patients treated with PROMACTA and placebo were 47 years and 52.5 years, respectively. Approximately half of the patients treated with PROMACTA and placebo (47% and 50%, respectively) were receiving concomitant ITP medication (predominantly corticosteroids) at randomization and had baseline platelet counts less than or equal to $15 \times 10^9/L$ (50% and 48%, respectively). A similar percentage of patients treated with PROMACTA and placebo (37% and 34%, respectively) had a prior splenectomy.

The efficacy of PROMACTA in this trial was evaluated by the odds of achieving a platelet count greater than or equal to $50 \times 10^9/L$ and less than or equal to $400 \times 10^9/L$ for patients receiving PROMACTA relative to placebo and was based on patient response profiles throughout the 6-month treatment period. In 134 patients who completed 26 weeks of treatment, a sustained platelet response (platelet count greater than or equal to $50 \times 10^9/L$ and less than or equal to $400 \times 10^9/L$ for 6 out of the last 8 weeks of the 26-week treatment period in the absence of rescue medication at any time) was achieved by 60% of patients treated with PROMACTA, compared with 10% of patients treated with placebo (splenectomized patients: PROMACTA 51%, placebo 8%; non-splenectomized patients: PROMACTA 66%, placebo 11%). The proportion of responders in the group of patients treated with PROMACTA was between 37% and 56% compared with 7% and 19% in the placebo treatment group for all on-therapy visits. Patients treated with PROMACTA were significantly more likely to achieve a platelet count between $50 \times 10^9/L$ and $400 \times 10^9/L$ during the entire 6-month treatment period compared with those patients treated with placebo.

Outcomes of treatment are presented in Table 17 for all patients enrolled in the trial.

Table 17. RAISE: Outcomes of Treatment in Adults With Chronic Immune Thrombocytopenia

Outcome	PROMACTA n = 135	Placebo n = 62
Mean number of weeks with platelet counts $\geq 50 \times 10^9/L$	11.3	2.4
Requiring rescue therapy, n (%)	24 (18)	25 (40)

Among 94 patients receiving other ITP therapy at baseline, 37 (59%) of 63 patients treated with PROMACTA and 10 (32%) of 31 patients in the placebo group discontinued concomitant therapy at some time during the trial.

In the EXTEND study (NCT00351468), patients who completed any prior clinical trial with PROMACTA were enrolled in an open-label, single-arm trial in which attempts were made to decrease the dose or eliminate the need for any concomitant ITP medications. PROMACTA was administered to 302 patients in EXTEND; 218 patients completed 1 year, 180 patients completed 2 years, 107 patients completed 3 years, 75 patients completed 4 years, 34 patients completed 5 years, and 18 patients completed 6 years of therapy. The median baseline platelet count was $19 \times 10^9/L$ prior to administration of PROMACTA. Median platelet counts at 1, 2, 3, 4, 5, 6, and 7 years on study were $85 \times 10^9/L$, $85 \times 10^9/L$, $105 \times 10^9/L$, $64 \times 10^9/L$, $75 \times 10^9/L$, $119 \times 10^9/L$, and $76 \times 10^9/L$, respectively.

Pediatric Patients: The efficacy and safety of PROMACTA in pediatric patients 1 year and older with chronic ITP were evaluated in two double-blind, placebo-controlled trials. The trials differed in time since ITP diagnosis: at least 6 months versus at least 12 months. During the trials, doses could be increased every 2 weeks to a maximum of 75 mg once daily. The dose of PROMACTA was reduced if the platelet count exceeded $200 \times 10^9/L$ and interrupted and reduced if it exceeded $400 \times 10^9/L$.

In the PETIT2 study (NCT01520909), patients refractory or relapsed to at least one prior ITP therapy with a platelet count less than $30 \times 10^9/L$ (n = 92) were stratified by age and randomized (2:1) to PROMACTA (n = 63) or placebo (n = 29). The starting dose for patients aged 6 to 17 years was 50 mg once daily for those at least 27 kg and 37.5 mg once daily for those less than 27 kg, administered as oral tablets. A reduced dose of 25 mg once daily was used for East Asian patients aged 6 to 17 years regardless of weight. The starting dose for patients aged 1 to 5 years was 1.2 mg/kg once daily (0.8 mg/kg once daily for East Asian patients) administered as oral suspension.

The 13-week, randomized, double-blind period was followed by a 24-week, open-label period where patients from both arms were eligible to receive PROMACTA.

The median age of the patients was 9 years and 48% were female. Approximately 62% of patients had a baseline platelet count less than or equal to $15 \times 10^9/L$, a characteristic that was similar between treatment arms. The percentage of patients with at least 2 prior ITP therapies (predominantly corticosteroids and immunoglobulins) was 73% in the group treated with PROMACTA and 90% in the group treated with placebo. Four patients in the group treated with PROMACTA had undergone splenectomy.

The efficacy of PROMACTA in this trial was evaluated by the proportion of subjects on PROMACTA achieving platelet counts $\geq 50 \times 10^9/L$ (in the absence of rescue therapy) for at least 6 out of 8 weeks between Weeks 5 to 12 of the randomized, double-blind period (Table 18).

Table 18. PETIT2: Platelet Count Response ($\geq 50 \times 10^9/L$ Without Rescue) for 6 out of 8 Weeks (between Weeks 5 to 12) Overall and by Age Cohort in Pediatric Patients 1 Year and Older With Chronic Immune Thrombocytopenia

Age Cohort	PROMACTA	Placebo
Overall	26/63 (41%) ^a	1/29 (3%)
12 to 17 years	10/24 (42%)	1/10 (10%)
6 to 11 years	11/25 (44%)	0/13 (0%)
1 to 5 years	5/14 (36%)	0/6 (0%)

^a *p*-value = < 0.001 for PROMACTA versus placebo.

More pediatric patients treated with PROMACTA (75%) compared with placebo (21%) had at least one platelet count greater than or equal to $50 \times 10^9/L$ during the first 12 weeks of randomized treatment in absence of rescue therapy. Fewer pediatric patients treated with PROMACTA required rescue treatment during the randomized, double-blind period compared with placebo-treated patients (19% [12/63] versus 24% [7/29]). In the patients who achieved a platelet response ($\geq 50 \times 10^9/L$ without rescue) for 6 out of 8 weeks (between weeks 5 to 12), 62% (16/26) had an initial response in the first 2 weeks after starting PROMACTA.

Patients were permitted to reduce or discontinue baseline ITP therapy only during the open-label phase of the trial. Among 15 patients receiving other ITP therapy at baseline, 53% (8/15) reduced (*n* = 1) or discontinued (*n* = 7) concomitant therapy, mainly corticosteroids, without needing rescue therapy.

In the PETIT study (NCT00908037), patients refractory or relapsed to at least one prior ITP therapy with a platelet count less than $30 \times 10^9/L$ (*n* = 67) were stratified by age and randomized (2:1) to PROMACTA (*n* = 45) or placebo (*n* = 22). The starting dose for patients aged 12 to 17 years was 37.5 mg once daily regardless of weight or race. The starting dose for patients aged 6 to 11 years was 50 mg once daily for those greater than or equal to 27 kg and 25 mg once daily for those less than 27 kg, administered as oral tablets. Reduced doses of 25 mg (for those greater than or equal to 27 kg) and 12.5 mg (for those less than 27 kg), each once daily, were used for East Asian patients in this age range. The starting dose for patients aged 1 to 5 years was 1.5 mg/kg once daily (0.8 mg/kg once daily for East Asian patients) administered as oral suspension.

The 7-week, randomized, double-blind period was followed by an open-label period of up to 24 weeks where patients from both arms were eligible to receive PROMACTA.

The median age of the patients was 10 years and 60% were female. Approximately 51% of patients had a baseline platelet count less than or equal to $15 \times 10^9/L$. The percentage of patients with at least 2 prior ITP therapies (predominantly corticosteroids and immunoglobulins) was 84% in the group treated with PROMACTA and 86% in the group treated with placebo. Five patients in the group treated with PROMACTA had undergone splenectomy.

The efficacy of PROMACTA in this trial was evaluated by the proportion of patients achieving platelet counts greater than or equal to $50 \times 10^9/L$ (in absence of rescue therapy) at least once between Weeks 1 and 6 of the randomized, double-blind period (Table 19). Platelet response to PROMACTA was consistent across the age cohorts.

Table 19. PETIT: Platelet Count Response ($\geq 50 \times 10^9/L$ Without Rescue) Rates in Pediatric Patients 1 Year and Older with Chronic Immune Thrombocytopenia

	PROMACTA	Placebo
Overall	28/45 (62%) ^a	7/22 (32%)
12 to 17 years	10/16 (62%)	0/8 (0%)
6 to 11 years	12/19 (63%)	3/9 (33%)
1 to 5 years	6/10 (60%)	4/5 (80%)

^a *p*-value = 0.011 for PROMACTA versus placebo.

Fewer pediatric patients treated with PROMACTA required rescue treatment during the randomized, double-blind period compared with placebo-treated patients (13% [6/45] versus 50% [11/22]).

Patients were permitted to reduce or discontinue baseline ITP therapy only during the open-label phase of the trial. Among 13 patients receiving other ITP therapy at baseline, 46% (6/13) reduced (*n* = 3) or discontinued (*n* = 3) concomitant therapy, mainly corticosteroids, without needing rescue therapy.

14.2 Chronic Hepatitis C-associated Thrombocytopenia

The efficacy and safety of PROMACTA for the treatment of thrombocytopenia in adult patients with chronic hepatitis C were evaluated in two randomized, double-blind, placebo-controlled trials. The ENABLE1 study (NCT00516321) utilized peginterferon alfa-2a (PEGASYS[®]) plus ribavirin for antiviral treatment and the ENABLE2 study (NCT00529568) utilized peginterferon alfa-2b (PEGINTRON[®]) plus ribavirin. In both trials, patients with a platelet count of less than $75 \times 10^9/L$ were enrolled and stratified by platelet count, screening HCV RNA, and HCV genotype. Patients were excluded if they had evidence of decompensated liver disease with Child-Pugh score greater than 6 (class B and C), history of ascites, or hepatic encephalopathy. The median age of the patients in both trials was 52 years, 63% were male, and 74% were Caucasian. Sixty-nine percent of patients had HCV genotypes 1, 4, 6, with the remainder genotypes 2 and 3. Approximately 30% of patients had been previously treated with interferon and ribavirin. The majority of patients (90%) had bridging fibrosis and cirrhosis, as indicated by noninvasive testing. A similar proportion (95%) of patients in both treatment groups had Child-Pugh Class A (score 5 to 6) at baseline. A similar proportion of patients (2%) in both treatment groups had baseline international normalized ratio (INR) greater than 1.7. Median baseline platelet counts (approximately $60 \times 10^9/L$) were similar in both treatment groups. The trials consisted of 2 phases – a pre-antiviral treatment phase and an antiviral treatment phase. In the pre-antiviral treatment phase, patients received open-label PROMACTA to increase the platelet count to a threshold of greater than or equal to $90 \times 10^9/L$ for ENABLE1 and greater than or equal to $100 \times 10^9/L$ for ENABLE2. PROMACTA was administered at an initial dose of 25 mg once daily for 2 weeks and increased in 25-mg increments over 2- to 3-week periods to achieve the optimal platelet count to initiate antiviral therapy. The maximal time patients could receive open-label PROMACTA was 9 weeks. If threshold platelet counts were achieved, patients were randomized (2:1) to the same dose of PROMACTA at the end of the pre-treatment phase or to placebo. PROMACTA was administered in combination with pegylated interferon and ribavirin per their respective prescribing information for up to 48 weeks.

The efficacy of PROMACTA for both trials was evaluated by sustained virologic response (SVR) defined as the percentage of patients with undetectable HCV-RNA at 24 weeks after completion of antiviral treatment. The median time to achieve the target platelet count greater than or equal to $90 \times 10^9/L$ was approximately 2 weeks. Ninety-five percent of patients were able to initiate antiviral therapy.

In both trials, a significantly greater proportion of patients treated with PROMACTA achieved SVR (see Table 20). The improvement in the proportion of patients who achieved SVR was consistent across subgroups based on baseline platelet count (less than $50 \times 10^9/L$ versus greater than or equal to $50 \times 10^9/L$). In patients with high baseline viral loads (greater than or equal to 800,000), the SVR rate was 18% (82/452) for PROMACTA versus 8% (20/239) for placebo.

Table 20. ENABLE1 and ENABLE2: Sustained Virologic Response (SVR) in Adults with Chronic Hepatitis C

Pre-antiviral Treatment Phase	ENABLE1 ^a		ENABLE2 ^b	
	n = 715		n = 805	
% Patients who achieved target platelet counts and initiated antiviral therapy ^c	95%		94%	
Antiviral Treatment Phase	PROMACTA n = 450 %	Placebo n = 232 %	PROMACTA n = 506 %	Placebo n = 253 %
Overall SVR^d	23	14	19	13
HCV Genotype 2,3	35	24	34	25
HCV Genotype 1,4,6	18	10	13	7

^a PROMACTA given in combination with peginterferon alfa-2a (180 mcg once weekly for 48 weeks for genotypes 1/4/6; 24 weeks for genotype 2 or 3) plus ribavirin (800 to 1,200 mg daily in 2 divided doses orally).

^b PROMACTA given in combination with peginterferon alfa-2b (1.5 mcg/kg once weekly for 48 weeks for genotypes 1/4/6; 24 weeks for genotype 2 or 3) plus ribavirin (800 to 1,400 mg daily in 2 divided doses orally).

^c Target platelet count was $\geq 90 \times 10^9/L$ for ENABLE1 and $\geq 100 \times 10^9/L$ for ENABLE2.

^d p -value < 0.05 for PROMACTA versus placebo.

The majority of patients treated with PROMACTA (76%) maintained a platelet count greater than or equal to $50 \times 10^9/L$ compared with 19% for placebo. A greater proportion of patients on PROMACTA did not require any antiviral dose reduction as compared with placebo (45% versus 27%).

14.3 Severe Aplastic Anemia

First-Line Treatment of Severe Aplastic Anemia

PROMACTA in combination with h-ATG and cyclosporine was investigated in a single-arm, single-center, open-label sequential cohort trial (Study ETB115AUS01T, referred to as Study US01T [NCT01623167]) in patients with severe aplastic anemia who had not received prior immunosuppressive therapy (IST) with any ATG, alemtuzumab, or high dose cyclophosphamide. A total of 153 patients received PROMACTA in Study US01T in three sequential cohorts and an extension of the third cohort. The multiple cohorts received the same PROMACTA starting dose but differed by treatment start day and duration. The starting dose of PROMACTA for patients 12 years and older was 150 mg once daily (a reduced dose of 75 mg was administered for East and Southeast Asians), 75 mg once daily for pediatric patients aged 6 to 11 years (a reduced dose of 37.5 mg was administered for East and Southeast Asians), and 2.5 mg/kg once daily for pediatric patients aged 2 to 5 years (a reduced dose of 1.25 mg/kg was administered for East and Southeast Asians).

- Cohort 1 (n=30): PROMACTA on Day 14 to Month 6 (D14-M6) plus h-ATG and cyclosporine
- Cohort 2 (n=31): PROMACTA on Day 14 to Month 3 (D14-M3) plus h-ATG and cyclosporine
- Cohort 3 + Extension cohort [PROMACTA D1-M6 cohort] (n = 92): PROMACTA on Day 1 to Month 6 (D1-M6) plus h-ATG and cyclosporine (with all patients eligible to receive low dose of cyclosporine (maintenance dose) if they achieved a hematologic response at 6 months)

PROMACTA dose reductions were conducted for elevated platelet counts and hepatic impairment. Table 21 includes the dosages of h-ATG and cyclosporine administered in combination with PROMACTA in Study US01T.

Data from the Cohort 3 + Extension cohort support the efficacy of PROMACTA for the first-line treatment of patients with severe aplastic anemia (Table 22). The results presented in this section represent the findings from the Cohort 3 and Extension cohort (n = 92).

Table 21. Dosages of Immunosuppressive Therapy Administered With PROMACTA in Study US01T

Agent	Dose Administered in the Pivotal Trial
Horse antithymocyte globulin (h-ATG)	40 mg/kg/day, based on actual body weight, administered intravenously on Days 1 to 4 of the 6-month treatment period
Cyclosporine ^a (therapeutic dose for 6 months, from Day 1 to Month 6, adjusted to obtain a target therapeutic trough level between 200 mcg/L and 400 mcg/L)	<p data-bbox="586 254 1333 401"><u>Patients 12 years and older (total daily dose of 6 mg/kg/day)</u> 3 mg/kg, based on actual body weight, orally every 12 hours for 6 months, starting on Day 1</p> <p data-bbox="586 436 1333 621"><i>Patients > 20 years of age with a body mass index > 35 or patients 12 to 20 years of age with a body mass index > 95th percentile:</i> 3 mg/kg, based on adjusted body weight^b, orally every 12 hours for 6 months, starting on Day 1</p> <p data-bbox="586 657 1333 804"><u>Patients 2 to 11 years of age (total daily dose of 12 mg/kg/day)</u> 6 mg/kg, based on actual body weight, orally every 12 hours for 6 months, starting on Day 1</p> <p data-bbox="586 840 1333 982"><i>Patients 2 to 11 years of age with a body mass index > 95th percentile:</i> 6 mg/kg, based on adjusted body weight^b, orally every 12 hours for 6 months, starting on Day 1</p>
Cyclosporine (maintenance dose, from Month 6 to Month 24)	<p data-bbox="586 989 1333 1129"><u>For patients who achieve a hematologic response at 6 months</u> 2 mg/kg/day administered orally at a fixed dose for an additional 18 months</p>

^a Dose of cyclosporine was adjusted to achieve the above recommended target trough levels; refer to the appropriate cyclosporine prescribing information.

^b Calculated as the midpoint between the ideal body weight and actual body weight.

In the PROMACTA D1-M6 cohort, the median age was 28 years (range 5 to 82 years) with 16% and 28% of patients ≥ 65 years of age and < 17 years of age, respectively. Forty-six percent of patients were male and the majority of patients were White (62%). Patients weighing 12 kg or less or patients with ALT or AST $> 5x$ upper limit of normal were excluded from the trial.

The efficacy of PROMACTA in combination with h-ATG and cyclosporine was established on the basis of complete hematological response at 6 months. A complete response was defined as hematological parameters meeting all 3 of the following values on 2 consecutive serial blood count measurements at least one week apart: absolute neutrophil count (ANC) $> 1000/\text{mcL}$, platelet count $> 100 \times 10^9/\text{L}$ and hemoglobin $> 10 \text{ g/dL}$. A partial response was defined as blood counts no longer meeting the standard criteria for severe pancytopenia in severe aplastic anemia equivalent to 2 of the following values on 2 consecutive serial blood count measurements at least one week apart: ANC $> 500/\text{mcL}$, platelet count $> 20 \times 10^9/\text{L}$, or reticulocyte count $> 60,000/\text{mcL}$. Overall response rate is defined as the number of partial responses plus complete responses.

Table 22. Study US01T: Hematologic Response in First-Line Treatment of Patients With Severe Aplastic Anemia

	PROMACTA D1-M6 + h-ATG + cyclosporine n = 92
Month 6, n^a	87
Overall response, n (%) [95% CI]	69 (79) [69, 87]
Complete response, n (%) [95% CI]	38 (44) [33, 55]
Median duration of overall response, n^b	70
Months (95% CI)	24.3 (21.4, NE)
Median duration of complete response, n^b	46
Months (95% CI)	24.3 (23.0, NE)

^a The number of patients who reached the 6-month assessment or withdrew earlier is the denominator for percentage calculation

^b Number of responders at any time

NE = not estimable

The overall and complete hematological response rates at Year 1 (n = 78) are 56.4% and 38.5% and at Year 2 (n = 62) are 38.7% and 30.6%, respectively.

Pediatric Patients

Thirty-four patients 2 to 16 years of age were enrolled in Study US01T. In the D1-M6 cohort, 7 and 17 out of 25 pediatric patients achieved a complete and overall response, respectively, at 6 months.

Refractory Severe Aplastic Anemia

PROMACTA was studied in a single-arm, single-center, open-label trial (Study ETB115AUS28T, referred to as Study US28T [NCT00922883]) in 43 patients with severe aplastic anemia who had an insufficient response to at least one prior immunosuppressive therapy and who had a platelet count less than or equal to $30 \times 10^9/L$. PROMACTA was administered at an initial dose of 50 mg once daily for 2 weeks and increased over 2-week periods up to a maximum dose of 150 mg once daily. The efficacy of PROMACTA in the study was evaluated by the hematologic response assessed after 12 weeks of treatment. Hematologic response was defined as meeting 1 or more of the following criteria: 1) platelet count increases to $20 \times 10^9/L$ above baseline, or stable platelet counts with transfusion independence for a minimum of 8 weeks; 2) hemoglobin increase by greater than 1.5 g/dL, or a reduction in greater than or equal to 4 units of red blood cell (RBC) transfusions for 8 consecutive weeks; 3) ANC increase of 100% or an ANC increase greater than $0.5 \times 10^9/L$. PROMACTA was discontinued after 16 weeks if no hematologic response was observed. Patients who responded continued therapy in an extension phase of the trial.

The treated population had median age of 45 years (range: 17 to 77 years) and 56% were male. At baseline, the median platelet count was $20 \times 10^9/L$, hemoglobin was 8.4 g/dL, ANC was $0.58 \times 10^9/L$, and absolute reticulocyte count was $24.3 \times 10^9/L$. Eighty-six percent of patients were RBC transfusion dependent and 91% were platelet transfusion dependent. The majority of patients (84%) received at least 2 prior immunosuppressive therapies. Three patients had cytogenetic abnormalities at baseline.

Table 23 presents the efficacy results.

Table 23. Study US28T: Hematologic Response in Patients with Refractory Severe Aplastic Anemia

Outcome	PROMACTA n = 43
Response rate ^a , n (%) 95% CI (%)	17 (40) (25, 56)
Median of duration of response in months (95% CI)	NR ^b (3.0, NR ^b)

^a Includes single- and multi-lineage.

^b NR = Not reached due to few events (relapsed).

In the 17 responders, the platelet transfusion-free period ranged from 8 to 1096 days with a median of 200 days, and the RBC transfusion-free period ranged from 15 to 1082 days with a median of 208 days.

In the extension phase, 8 patients achieved a multi-lineage response; 4 of these patients subsequently tapered off treatment with PROMACTA and maintained the response (median follow up: 8.1 months, range: 7.2 to 10.6 months).

16 HOW SUPPLIED/STORAGE AND HANDLING

16.1 Tablets

- The 12.5-mg tablets are round, biconvex, white, film-coated tablets debossed with GS MZ1 and 12.5 on one side and are available in bottles of 30: NDC 0078-0684-15
- The 25-mg tablets are round, biconvex, orange, film-coated tablets debossed with GS NX3 and 25 on one side and are available in bottles of 30: NDC 0078-0685-15
- The 50-mg tablets are round, biconvex, blue, film-coated tablets debossed with GS UFU and 50 on one side and are available in bottles of 30: NDC 0078-0686-15
- The 75-mg tablets are round, biconvex, pink, film-coated tablets debossed with GS FFS and 75 on one side and are available in bottles of 30: NDC 0078-0687-15

Store at room temperature between 20°C and 25°C (68°F to 77°F); excursions permitted to 15°C to 30°C (59°F to 86°F) [*see USP Controlled Room Temperature*]. Dispense in original bottle.

16.2 For Oral Suspension

- The 12.5-mg for oral suspension is a reddish-brown to yellow powder in unit-dose packets, co-packaged in a kit with a 40-cc reconstitution vessel, a threaded closure with syringe-port capability, and 30 single-use oral dosing syringes.

Each kit (NDC 0078-0972-61) contains 30 packets: NDC 0078-0972-19.

- The 25-mg for oral suspension is a reddish-brown to yellow powder in unit-dose packets, co-packaged in a kit with a 40-cc reconstitution vessel, a threaded closure with syringe-port capability, and 30 single-use oral dosing syringes.

Each kit (NDC 0078-0697-61) contains 30 packets: NDC 0078-0697-19

Store at room temperature between 20°C and 25°C (68°F to 77°F); excursions permitted to 15°C to 30°C (59°F to 86°F) [*see USP Controlled Room Temperature*]. Following reconstitution, the product should be administered immediately but may be stored for a maximum period of 30 minutes between 20°C and 25°C (68°F to 77°F); excursions permitted to 15°C to 30°C (59°F to 86°F) [*see USP Controlled Room Temperature*]. Throw away (discard) the mixture if not used within 30 minutes.

17 PATIENT COUNSELING INFORMATION

Advise the patient or caregiver to read the FDA-approved patient labeling (Medication Guide and Instructions for Use).

Prior to treatment, patients should fully understand and be informed of the following risks and considerations for PROMACTA:

Risks

Hepatotoxicity

- Therapy with PROMACTA may be associated with hepatobiliary laboratory abnormalities [*see Warnings and Precautions (5.2)*].
- Advise patients with chronic hepatitis C and cirrhosis that they may be at risk for hepatic decompensation when receiving PROMACTA with alfa interferon therapy [*see Warnings and Precautions (5.1)*].

- Advise patients that they should report any of the following signs and symptoms of liver problems to their healthcare provider right away [*see Warnings and Precautions (5.2)*].
 - yellowing of the skin or the whites of the eyes (jaundice)
 - unusual darkening of the urine
 - unusual tiredness
 - right upper stomach area pain
 - confusion
 - swelling of the stomach area (abdomen)

Risk of Bleeding Upon PROMACTA Discontinuation

- Advise patients that thrombocytopenia and risk of bleeding may reoccur upon discontinuing PROMACTA, particularly if PROMACTA is discontinued while the patient is on anticoagulants or antiplatelet agents. Advise patients that during therapy with PROMACTA, they should continue to avoid situations or medications that may increase the risk for bleeding.

Thrombotic/Thromboembolic Complications

- Advise patients that too much PROMACTA may result in excessive platelet counts and a risk for thrombotic/thromboembolic complications [*see Warnings and Precautions (5.4)*].

Cataracts

- Advise patients to have a baseline ocular examination prior to administration of PROMACTA and be monitored for signs and symptoms of cataracts during therapy [*see Warnings and Precautions (5.5)*].

Drug Interactions

- Advise patients to take PROMACTA at least 2 hours before or 4 hours after calcium-rich foods, mineral supplements, and antacids which contain polyvalent cations such as iron, calcium, aluminum, magnesium, selenium, and zinc [*see Dosage and Administration (2.4), Drug Interactions (7.1)*].

Lactation

- Advise women not to breastfeed during treatment with PROMACTA [*see Use in Specific Populations (8.2)*].

Administration of PROMACTA

- For patients with chronic ITP, therapy with PROMACTA is administered to achieve and maintain a platelet count greater than or equal to $50 \times 10^9/L$ as necessary to reduce the risk for bleeding [*see Indications and Usage (1.1)*].
- For patients with chronic hepatitis C, therapy with PROMACTA is administered to achieve and maintain a platelet count necessary to initiate and maintain antiviral therapy with pegylated interferon and ribavirin [*see Indications and Usage (1.2)*].
 - Advise patients to take PROMACTA without a meal or with a meal low in calcium (≤ 50 mg) and at least 2 hours before or 4 hours after other medications (e.g., antacids) and calcium-rich foods [*see Dosage and Administration (2.4)*].
- Prior to use of the oral suspension, ensure patients or caregivers receive training on proper dosing, preparation, and administration [*see Dosage and Administration (2.4)*].
- Inform patients or caregivers how many packets to administer to get the full dose [*see Instructions for Use*].
- Inform patients or caregivers to use a new oral dosing syringe to prepare each dose of PROMACTA for oral suspension [*see Instructions for Use*].

The following are registered trademarks of their respective owners: PEGASYS/Hoffmann-La Roche Inc.; PEGINTRON/Schering Corporation.

Distributed by:

Novartis Pharmaceuticals Corporation

East Hanover, New Jersey 07936

© Novartis

MEDICATION GUIDE

PROMACTA® (pro-MAC-ta)
(eltrombopag)
tablets

PROMACTA® (pro-MAC-ta)
(eltrombopag)
for oral suspension

What is the most important information I should know about PROMACTA?

PROMACTA can cause serious side effects, including:

Liver problems:

- If you have chronic hepatitis C virus and take PROMACTA with interferon and ribavirin treatment, PROMACTA may increase your risk of liver problems. If your healthcare provider tells you to stop your treatment with interferon and ribavirin, you will also need to stop taking PROMACTA.
- PROMACTA may increase your risk of liver problems that may be severe and possibly life threatening. Your healthcare provider will do blood tests to check your liver function before you start taking PROMACTA and during your treatment. Your healthcare provider may stop your treatment with PROMACTA if you have changes in your liver function blood tests.

Tell your healthcare provider right away if you have any of these signs and symptoms of liver problems:

- yellowing of the skin or the whites of the eyes (jaundice)
- unusual darkening of the urine
- unusual tiredness
- right upper stomach area (abdomen) pain
- confusion
- swelling of the stomach area (abdomen)

See “What are the possible side effects of PROMACTA?” for other side effects of PROMACTA.

What is PROMACTA?

PROMACTA is a prescription medicine used to treat adults and children 1 year of age and older with low blood platelet counts due to chronic immune thrombocytopenia (ITP), when other medicines to treat ITP or surgery to remove the spleen have not worked well enough.

PROMACTA is also used to treat people with:

- low blood platelet counts due to chronic hepatitis C virus (HCV) infection before and during treatment with interferon.
- severe aplastic anemia (SAA) in combination with other medicines to treat SAA, as the first treatment for adults and children 2 years of age and older.
- severe aplastic anemia (SAA) when other medicines to treat SAA have not worked well enough.

PROMACTA is used to try to raise platelet counts in order to lower your risk for bleeding.

PROMACTA is not used to make platelet counts normal.

PROMACTA is not for use in people with a pre-cancerous condition called myelodysplastic syndrome (MDS), or in people with low platelet counts caused by certain other medical conditions or diseases.

It is not known if PROMACTA is safe and effective when used with other antiviral medicines to treat chronic hepatitis C.

It is not known if PROMACTA is safe and effective in children:

- younger than 1 year with ITP
- with low blood platelet counts due to chronic hepatitis C
- whose severe aplastic anemia (SAA) has not improved after previous treatments.
- younger than 2 years when used in combination with other medicines to treat SAA as the first treatment for SAA.

Before you take PROMACTA, tell your healthcare provider about all of your medical conditions, including if you:

- have liver problems
- have a precancerous condition called MDS or a blood cancer
- have or had a blood clot
- have a history of cataracts
- have had surgery to remove your spleen (splenectomy)
- have bleeding problems
- are of Asian ancestry (such as Chinese, Japanese, Taiwanese, or Korean). You may need a lower dose of PROMACTA.

- are pregnant or plan to become pregnant. It is not known if PROMACTA will harm an unborn baby. Tell your healthcare provider if you become pregnant or think you may be pregnant during treatment with PROMACTA.
 - Females who are able to become pregnant, should use effective birth control (contraception) during treatment with PROMACTA and for at least 7 days after stopping treatment with PROMACTA. Talk to your healthcare provider about birth control methods that may be right for you during this time.
- are breastfeeding or plan to breastfeed. You should not breastfeed during your treatment with PROMACTA. Talk to your healthcare provider about the best way to feed your baby during this time.
- **Tell your healthcare provider about all the medicines you take**, including prescription and over-the-counter medicines, vitamins, and herbal supplements. PROMACTA may affect the way certain medicines work. Certain other medicines may affect the way PROMACTA works.

Especially tell your healthcare provider if you take:

- certain medicines used to treat high cholesterol, called “statins”
- a blood thinner medicine

Certain medicines may keep PROMACTA from working correctly. Take PROMACTA at least 2 hours before or 4 hours after taking these products:

- antacid medicine used to treat stomach ulcers or heartburn
- multivitamins or products that contain iron, calcium, aluminum, magnesium, selenium, and zinc which may be found in mineral supplements

Ask your healthcare provider if you are not sure if your medicine is one that is listed above.

Know the medicines you take. Keep a list of them and show it to your healthcare provider and pharmacist when you get a new medicine.

How should I take PROMACTA?

- Take PROMACTA exactly as your healthcare provider tells you to take it. Your healthcare provider will prescribe the dose of PROMACTA tablets or PROMACTA for oral suspension that is right for you.
- If your healthcare provider prescribes PROMACTA tablets, take PROMACTA tablets whole. **Do not split, chew, or crush PROMACTA tablets and do not mix with food or liquids.**
- If your healthcare provider prescribes PROMACTA for oral suspension, see the “**Instructions for Use**” that comes with your medicine for instructions on how to correctly mix and take a dose of PROMACTA.
- Use a new single-use oral dosing syringe to prepare each dose of PROMACTA for oral suspension. **Do not re-use the oral dosing syringe.**
- **Do not** stop taking PROMACTA without talking with your healthcare provider first. Do not change your dose or schedule for taking PROMACTA unless your healthcare provider tells you to change it.
- Take Promacta without a meal or with a meal low in calcium (50 mg or less) and at least 2 hours before or 4 hours after eating calcium-rich foods such as dairy products, calcium-fortified juices, and certain fruits and vegetables.
- If you miss a dose of PROMACTA, wait and take your next scheduled dose. Do not take more than 1 dose of PROMACTA in 1 day.
- If you take too much PROMACTA, you may have a higher risk of serious side effects. Call your healthcare provider right away.
- Your healthcare provider will check your platelet count during your treatment with PROMACTA and change your dose of PROMACTA as needed.
- Tell your healthcare provider about any bruising or bleeding that happens while you take and after you stop taking PROMACTA.
- If you have SAA, your healthcare provider may do tests to monitor your bone marrow during treatment with PROMACTA.

What should I avoid while taking PROMACTA?

Avoid situations and medicines that may increase your risk of bleeding.

What are the possible side effects of PROMACTA?

PROMACTA may cause serious side effects, including:

- See “**What is the most important information I should know about PROMACTA?**”
- **Increased risk of worsening of a precancerous blood condition called myelodysplastic syndrome (MDS) to acute myelogenous leukemia (AML).** PROMACTA is not for use in people with a precancerous condition called myelodysplastic syndromes (MDS). See “**What is PROMACTA?**” If you have MDS and receive PROMACTA, you have an increased risk that your MDS condition may worsen and become a blood cancer called AML. If your MDS worsens to become AML, you may have an increased risk of death from AML.
- **High platelet counts and higher risk for blood clots.** Your risk of getting a blood clot is increased if your platelet count is too high during treatment with PROMACTA. Your risk of getting a blood clot may also be increased during treatment with PROMACTA if you have normal or low platelet counts. You may have severe problems or die from some forms of blood clots, such as clots that travel to the lungs or that cause heart attacks or strokes. Your healthcare provider will check your blood platelet counts, and change your dose or stop PROMACTA if your platelet counts get too high. Tell your healthcare provider right away if you have signs and symptoms of a blood clot in the leg, such as swelling, pain, or tenderness in your leg.
People with chronic liver disease may be at risk for a type of blood clot in the stomach area (abdomen). Tell your healthcare provider right away if you have stomach-area (abdomen) pain, nausea, vomiting, or diarrhea as these may be symptoms of this type of blood clot.
- **New or worsened cataracts (a clouding of the lens in the eye).** New or worsened cataracts can happen in people taking PROMACTA. Your healthcare provider will check your eyes before and during your treatment with PROMACTA. Tell your healthcare provider about any changes in your eyesight while taking PROMACTA.

The most common side effects of PROMACTA in adults and children include:

- low red blood cell count (anemia)
- cough
- nausea
- tiredness
- fever
- headache
- abnormal liver function tests
- diarrhea

Laboratory tests may show abnormal changes to the cells in your bone marrow.

Tell your healthcare provider if you have any side effect that bothers you or that does not go away. These are not all of the possible side effects of PROMACTA. For more information, ask your healthcare provider or pharmacist.

Call your doctor for medical advice about side effects. You may report side effects to FDA at 1-800-FDA-1088.

How should I store PROMACTA tablets and PROMACTA for oral suspension?

Tablets:

- Store PROMACTA tablets at room temperature between 68°F to 77°F (20°C to 25°C).
- Keep PROMACTA in the bottle given to you.

For oral suspension:

- Store PROMACTA for oral suspension at room temperature between 68°F to 77°F (20°C to 25°C).
- After mixing, PROMACTA should be taken right away but may be stored for no more than 30 minutes between 68°F to 77°F (20°C to 25°C). Throw away (discard) the mixture if not used within 30 minutes.

Keep PROMACTA and all medicines out of the reach of children.

General information about the safe and effective use of PROMACTA

Medicines are sometimes prescribed for purposes other than those listed in a Medication Guide. Do not use PROMACTA for a condition for which it was not prescribed. Do not give PROMACTA to other people, even if they have the same symptoms that you have. It may harm them.

You can ask your healthcare provider or pharmacist for information about PROMACTA that is written for health professionals.

What are the ingredients in PROMACTA?

Tablets:

Active ingredient: eltrombopag olamine

Inactive ingredients:

- **Tablet Core:** magnesium stearate, mannitol, microcrystalline cellulose, povidone, and sodium starch glycolate.
- **Coating:** FD&C Blue No. 2 aluminum lake (50-mg tablet), FD&C Yellow No. 6 aluminum lake (25-mg tablet), hypromellose, Iron Oxide Black and Iron Oxide Red (75-mg tablet), polyethylene glycol 400, polysorbate 80 (12.5-mg tablet), or titanium dioxide.

For oral suspension:

Active ingredient: eltrombopag olamine.

Inactive ingredients: mannitol, sucralose, and xanthan gum

Distributed by: Novartis Pharmaceuticals Corporation East Hanover, New Jersey 07936 © Novartis T20xx-xx

For more information about PROMACTA, go to www.PROMACTA.com or call 1-888-669-6682.

This Medication Guide has been approved by the U.S. Food and Drug Administration

Revised 04/2020



INSTRUCTIONS FOR USE
PROMACTA® [pro-MAC-ta]
(eltrombopag)
for oral suspension

Read all the Instructions for Use and follow the steps below to mix and give a dose of PROMACTA for oral suspension.

Important information you need to know before taking PROMACTA for oral suspension:

- **Do not take PROMACTA for oral suspension or give it to someone else until you have been shown how to properly mix and give a dose of PROMACTA for oral suspension.** Your healthcare provider or nurse will show you how to mix and give a dose of PROMACTA for oral suspension properly.
- **PROMACTA for oral suspension must be mixed with cool or cold water only.** Do not use hot water to prepare the oral suspension.
- Give the dose of suspension right away after mixing with water. **If the medicine is not given within 30 minutes, you will have to mix a new dose.** Throw away (discard) the unused mixture into the trash. Do not pour it down the drain.
- If PROMACTA for oral suspension comes in contact with your skin, wash the skin right away with soap and water. Call your healthcare provider if you have a skin reaction or if you have any questions. If you spill any powder or liquid, follow the clean-up instructions in **Step 12**.
- Contact your healthcare provider or pharmacist if you have any questions about how to mix or give PROMACTA to your child, or if you damage or lose any of the supplies in your kit.
- **Do not** re-use the oral dosing syringe. Use a new single-use oral dosing syringe to prepare each dose of PROMACTA for oral suspension.
- After you have used all 30 packets, throw all the remaining supplies (mixing bottle, lid with cap, and oral dosing syringe) away in the trash.

Each PROMACTA for oral suspension kit contains the following supplies:

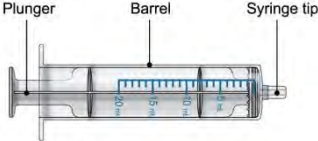
30 packets of PROMACTA for oral suspension	
1 Reusable mixing bottle with lid and cap	
30 Single-use 20-mL oral dosing syringes (Use a new (single-use) oral dosing syringe to prepare each dose of PROMACTA for oral suspension)	

You will need the following to give a dose of PROMACTA for oral suspension.

From the kit:

- prescribed number of packets
- 1 reusable mixing bottle with lid and cap. **Note:** Due to its small size, the cap may pose a danger of choking to small children.

- 1 single-use 20-mL oral dosing syringe (Use a new (single-use) oral dosing syringe to prepare each dose of PROMACTA for oral suspension)

Not included in the kit:

- 1 clean glass or cup filled with drinking water
- scissors to cut packet
- paper towels or disposable cloth
- disposable gloves (optional)

How do I prepare a dose of PROMACTA for oral suspension?

Step 1. Make sure that the mixing bottle, cap, lid and oral dosing syringe are dry before use. Remove the lid from the mixing bottle.

- **Prepare a clean, flat work surface.**
- **Wash and dry your hands before preparing the medicine.**

Step 2. Fill the oral dosing syringe with 20 mL of drinking water from the glass or cup.

- Start with the plunger pushed all the way into the syringe.
- Place the tip of the oral dosing syringe all the way into the water and pull back on the plunger to the 20 mL mark on the barrel of the oral dosing syringe.

Note: Use a new (single-use) oral dosing syringe to prepare each dose of PROMACTA for oral suspension.

Figure 1.



Step 3. Place the tip of the oral dosing syringe into the open mixing bottle. Empty water into open mixing bottle by slowly pushing the plunger all the way into the oral dosing syringe.

Figure 2.



Step 4. Take only the prescribed number of packets for one dose out of the kit. You may need to use more than one packet to prepare the entire dose.

12.5 mg packets

Dose	Number of 12.5 mg Packets Needed
12.5 mg dose	1 packet
25 mg dose	2 packets
50 mg dose	4 packets
75 mg dose	6 packets

25 mg packets

Dose	Number of 25 mg Packets Needed
12.5 mg dose	1 packet (Note: See Step 9 for instructions on how to give a 12.5-mg dose using a 25-mg packet.)
25 mg dose	1 packet
50 mg dose	2 packets
75 mg dose	3 packets

Step 5. Add the prescribed number of packets to the mixing bottle.

- Tap the top of each packet to make sure the contents fall to the bottom.
- Cut off the top of the packet with scissors and empty the entire contents of the packet into the mixing bottle.
- Make sure not to spill the powder outside the mixing bottle.

Figure 5.



Step 6. Screw the lid tightly onto the mixing bottle. Make sure the cap is pushed onto the lid.

Step 7. Gently and slowly shake the mixing bottle back and forth for at least 20 seconds to mix the water with the powder.

- To prevent the mixture from foaming, do not shake the mixing bottle hard.

Figure 6.



How should I give a dose of PROMACTA for oral suspension?

Step 8. Make sure the plunger is pushed all the way into the oral dosing syringe. Pull cap off the mixing bottle lid and insert the tip of the oral dosing syringe into the hole in the lid.

Step 9. Transfer the mixture into the oral dosing syringe. The liquid will be dark brown in color.

- Turn the mixing bottle upside down along with the oral dosing syringe.
 - Pull back the plunger:
 - 12.5-mg packet
 - until all the medicine is in the oral dosing syringe (12.5-mg, 25-mg, 50-mg, or 75-mg dose)
 - 25-mg packet
 - to the 10 mL mark on the oral dosing syringe for a **12.5-mg dose only**
- OR**
- until all the medicine is in the oral dosing syringe (25-mg, 50-mg, or 75-mg dose).

Figure 7.

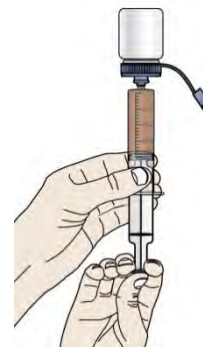

Step 10. Return the mixing bottle to the upright position and remove the oral dosing syringe from the mixing bottle.

Figure 8.



Step 11. Giving a dose of PROMACTA for oral suspension to a child.

- Place the tip of the oral dosing syringe into the inside of the child's cheek.
- Slowly push the plunger all the way down to give the entire dose. Make sure the child has time to swallow the medicine.

Figure 9.

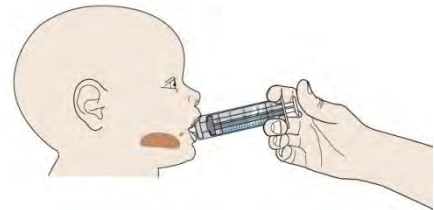

How should I clean up?

Step 12. Carefully clean up any spill of the powder or suspension with a damp paper towel or disposable cloth.

- To avoid possibly staining your skin, consider using disposable gloves.
- Throw away (discard) used paper towel or disposable cloth and gloves in the trash.

Step 13. Clean the mixing supplies.

- **Do not reuse any of the mixture remaining in the mixing bottle.**
- Throw away (discard) any mixture remaining in the mixing bottle in the trash. Do not pour down the drain.
- Throw away (discard) the used oral dosing syringe. Use a new (single-use) oral dosing syringe to prepare each dose of PROMACTA for oral suspension.
- Rinse the mixing bottle and lid under running water and air dry. The mixing bottle may become stained from the medicine. This is normal.
- Wash hands with soap and water.

How should I store PROMACTA for oral suspension?

- Store PROMACTA for oral suspension at room temperature between 68°F to 77°F (20°C to 25°C).
- After mixing, PROMACTA should be taken right away but may be stored for no more than 30 minutes between 68°F to 77°F (20°C to 25°C). Throw away (discard) the mixture if not used within 30 minutes.

Keep PROMACTA and all medicines out of the reach of children.

Distributed by:
Novartis Pharmaceuticals Corporation
East Hanover, New Jersey 07936

© Novartis

This Instructions for Use has been approved by the U.S. Food and Drug Administration.

Revised: 04/2020

PRODUCT MONOGRAPH
INCLUDING PATIENT MEDICATION INFORMATION

Pr **RAVICTI**TM

(glycerol phenylbutyrate) Oral Liquid

1.1 g/mL

Alimentary Tract and Metabolism Product (ATC Code: A16A X09)

Horizon Pharma Ireland Ltd.
Connaught House, 1st Floor
1 Burlington Road
Dublin 4 Ireland

Date of Preparation:
March 16, 2016

Submission Control No: 174219

Table of Contents

PART I: HEALTH PROFESSIONAL INFORMATION	3
SUMMARY PRODUCT INFORMATION	3
INDICATIONS AND CLINICAL USE.....	3
CONTRAINDICATIONS	4
WARNINGS AND PRECAUTIONS.....	4
ADVERSE REACTIONS.....	5
DRUG INTERACTIONS	8
DOSAGE AND ADMINISTRATION	9
OVERDOSAGE	11
ACTION AND CLINICAL PHARMACOLOGY	11
STORAGE AND STABILITY.....	14
DOSAGE FORMS, COMPOSITION AND PACKAGING	14
PART II: SCIENTIFIC INFORMATION	15
PHARMACEUTICAL INFORMATION.....	15
CLINICAL TRIALS.....	15
DETAILED PHARMACOLOGY	21
TOXICOLOGY	22
PART III: PATIENT MEDICATION INFORMATION	24

Pr **RAVICTI™**

(glycerol phenylbutyrate) Oral Liquid

PART I: HEALTH PROFESSIONAL INFORMATION

SUMMARY PRODUCT INFORMATION

Route of Administration	Dosage Form / Strength	Clinically Relevant Nonmedicinal Ingredients
Oral	Oral Liquid, 1.1 g/mL	There are no nonmedicinal ingredients <i>For a complete listing see Dosage Forms, Composition and Packaging section.</i>

INDICATIONS AND CLINICAL USE

RAVICTI should be prescribed by a physician experienced in the management of urea cycle disorders (UCDs).

RAVICTI (glycerol phenylbutyrate) is indicated for:

Use as a nitrogen-binding agent for chronic management of adult and pediatric patients ≥ 2 years of age with UCDs who cannot be managed by dietary protein restriction and/or amino acid supplementation alone. RAVICTI should be used with dietary protein restriction and, in some cases, dietary supplements (e.g., essential amino acids, arginine, citrulline, and protein-free calorie supplements).

Limitations of Use:

RAVICTI is not indicated for treatment of acute hyperammonemia in patients with UCDs.

Safety and efficacy for treatment of patients with *N*-acetylglutamate synthase (NAGS) deficiency have not been established.

Geriatrics (> 65 years of age)

Clinical studies of RAVICTI did not include sufficient numbers of subjects ≥ 65 years of age to determine whether they respond differently than younger subjects (see WARNINGS AND PRECAUTIONS, *Special Populations*).

Pediatrics

Patients < 2 Months of Age

The use of RAVICTI in this age group is contraindicated (see WARNINGS AND PRECAUTIONS, *Special Populations*).

Patients > 2 months and < 2 years of Age

The safety and efficacy of RAVICTI in this age group have not been established.

CONTRAINDICATIONS

RAVICTI is contraindicated in patients who are:

- hypersensitive to RAVICTI or its metabolites (phenylbutyric acid [PBA], phenylacetic acid [PAA], and phenylacetylglutamine [PAGN])
- <2 months of age
- breastfeeding

WARNINGS AND PRECAUTIONS

General

Acute hyperammonemic encephalopathy may occur in a number of patients even when they are on therapy.

RAVICTI is not recommended for the management of acute hyperammonemia, which is a medical emergency.

Cardiovascular

RAVICTI is associated with an increase in heart rate (see ACTION AND CLINICAL PHARMACOLOGY, *Cardiac Electrophysiology*). Caution should be observed in patients who have conditions that could be worsened by an increase in heart rate such as tachyarrhythmias or ischemic heart disease.

Hepatic

Since the metabolism and excretion of RAVICTI involves the liver, RAVICTI should be used with caution in patients with hepatic insufficiency (see ACTION AND CLINICAL PHARMACOLOGY, *Hepatic Insufficiency*).

Neurologic

The major metabolite of RAVICTI, PAA, is associated with signs and symptoms of neurotoxicity, including somnolence, fatigue, lightheadedness, headache, dysgeusia, hypoacusis, disorientation, impaired memory, and exacerbation of preexisting neuropathy were observed at plasma PAA concentrations ≥ 500 $\mu\text{g/mL}$ in a study of cancer patients who were administered intravenous (IV) PAA. In this study, adverse events were reversible.

In controlled clinical trials in UCD patients who had been on sodium phenylbutyrate prior to administration of RAVICTI, mean (standard deviation or SD) maximum PAA concentrations after dosing with RAVICTI were 38.5 (102.6) $\mu\text{g/mL}$ in adult patients and 87.3 (11.5) $\mu\text{g/mL}$ in pediatric patients (N=26). No correlation between PAA levels and neurotoxicity symptoms was identified in UCD patients.

If symptoms of vomiting, nausea, headache, somnolence, confusion, or sleepiness are present in the absence of high ammonia or other intercurrent illnesses, measure plasma PAA and plasma PAA to PAGN and consider reduction of RAVICTI dosage if the PAA level exceeds 500 $\mu\text{g/mL}$ or the PAA:PAGN ratio exceeds 2.5.

Pancreatic Insufficiency

Pancreatic lipases may be necessary for intestinal hydrolysis of RAVICTI, allowing release of PBA and subsequent formation of PAA, the active moiety. It is not known whether pancreatic and extrapancreatic lipases are sufficient for hydrolysis of RAVICTI. If there is inadequate intestinal hydrolysis of RAVICTI, impaired absorption of PBA and hyperammonemia could occur.

Renal

RAVICTI has not been studied in patients with impaired renal function. As RAVICTI excretion involves the kidneys, it should be used with caution in patients with renal insufficiency, including those with end-stage renal disease (ESRD) or those on hemodialysis.

Special Populations

Pregnant Women: There are no adequate and well controlled studies of RAVICTI in pregnant women. Studies in rats have shown reproductive toxicity (see TOXICOLOGY, *Reproductive Toxicology*). RAVICTI should be used during pregnancy only if the potential benefit justifies the potential risk to the fetus.

Nursing Women: It is unknown if RAVICTI is excreted in human milk. It has not been determined if RAVICTI or its metabolites are secreted in human milk and therefore the use of RAVICTI is contraindicated during breastfeeding (see CONTRAINDICATIONS).

Pediatrics

Patients <2 Months of Age: The use of RAVICTI in this age group is contraindicated. Children under 2 months of age may have immature pancreatic exocrine function that could impair RAVICTI hydrolysis and release of PBA as well as subsequent formation of PAA, the active moiety. If pancreatic and extrapancreatic lipases are insufficient for hydrolysis of RAVICTI in this age group, impaired absorption of PBA and hyperammonemia could occur.

Patients <2 Years of Age: The safety and efficacy of RAVICTI in this age group have not been established.

Geriatrics (> 65 years of age): Clinical studies of RAVICTI did not include sufficient numbers of subjects ≥ 65 years of age to determine whether they respond differently than younger subjects. In general, dose selection for a newly diagnosed elderly patient should be cautious, usually starting at the low end of the dosing range, reflecting the greater frequency of concomitant disease, including decreased hepatic or renal function, or concomitant drug therapy.

Monitoring and Laboratory Tests: Adjustment may be based on monitoring of plasma ammonia, glutamine, urinary phenylacetylglutamine (UPAGN) and/or plasma PAA and PAGN as well as the ratio of plasma PAA to PAGN (see Recommended Dose and Dosage Adjustment).

ADVERSE REACTIONS

Adverse Drug Reaction Overview

The incidence of serious adverse events in long term clinical trials with RAVICTI was 26% and consisted primarily of hyperammonemia (18%).

The most common adverse drug reactions among all patients taking RAVICTI in clinical trials include diarrhea, flatulence headache, decreased appetite, vomiting, nausea, fatigue and skin odor.

Adverse drug reactions that resulted in clinical intervention in UCD patients who participated in clinical trials were mostly gastrointestinal reactions (flatulence, nausea, vomiting, abdominal distention) or neurological reactions (dysgeusia, lethargy, speech disorder, paresthesia, tremor).

Clinical Trial Adverse Drug Reactions

Because clinical trials are conducted under very specific conditions, the adverse reaction rates observed in the clinical trials may not reflect the rates observed in practice and should not be compared to the rates in the clinical trials of another drug. Adverse drug reaction information from clinical trials is useful for identifying drug-related adverse events and for approximating rates.

Assessment of adverse drug reactions was based on exposure in 114 UCD patients (65 adults and 49 children between the ages of 2 months and 17 years) across four short term active control studies and three long term (12 month) uncontrolled clinical studies. Table 1 shows the adverse reactions reported in $\geq 2\%$ of patients receiving RAVICTI.

Table 1: Adverse Reactions Reported in $\geq 2\%$ of UCD Patients in Clinical Trials

System Organ Class Preferred Term	Number (%) of Patient in Pooled Studies	
	Short-Term Controlled Studies (N=80)	Long-Term Open-Label Studies (N=100)
Gastrointestinal disorders		
Abdominal distension	2 (2.5)	2 (2.0)
Abdominal pain	3 (3.8)	2 (2.0)
Abdominal pain upper	2 (2.5)	4 (4.0)
Constipation	1 (1.3)	2 (2.0)
Diarrhoea	7 (8.8)	4 (4.0)
Dyspepsia	2 (2.5)	3 (3.0)
Flatulence	7 (8.8)	3 (3.0)
Gastroesophageal reflux disease	0	0
Nausea	1 (1.3)	5 (5.0)
Oral discomfort	0	2 (2.0)
Retching	0	2 (2.0)
Vomiting	1 (1.3)	7 (7.0)
General disorders and administration site conditions		
Fatigue	3 (3.8)	4 (4.0)
Investigations		
Anion gap increased	0	2 (2.0)
Vitamin D decreased	0	2 (2.0)

Table 1: Adverse Reactions Reported in $\geq 2\%$ of UCD Patients in Clinical Trials (continued)

System Organ Class Preferred Term	Number (%) of Patient in Pooled Studies	
	Short-Term Controlled Studies (N=80)	Long-Term Open-Label Studies (N=100)
Metabolism and nutrition disorders		
Decreased appetite	1 (1.3)	7 (7.0)
Increased appetite	3 (3.8)	2 (2.0)
Nervous system disorders		
Dizziness	0	3 (3.0)
Headache	7 (8.8)	3 (3.0)
Tremor	0	2 (2.0)
Psychiatric disorders		
Food aversion	0	2 (2.0)
Reproductive system and breast disorders		
Metrorrhagia	0	2 (2.0)
Skin and subcutaneous tissue disorders		
Acne	0	2 (2.0)
Skin odour abnormal	0	6 (6.0)

Less Common Clinical Trial Adverse Drug Reactions (<2%)

Table 2: Less Common Clinical Trial Adverse Drug Reactions (<2%)

System Organ Class Preferred Term	Overall (N=114)
Gastrointestinal disorders	
Abdominal discomfort	1 (0.9%)
Abnormal faeces	1 (0.9%)
Defaecation urgency	1 (0.9%)
Dry mouth	1 (0.9%)
Eructation	1 (0.9%)
Gastrointestinal pain	1 (0.9%)
Painful defaecation	1 (0.9%)
Steatorrhoea	1 (0.9%)
Stomatitis	1 (0.9%)
Musculoskeletal and connective tissue disorders	
Muscle spasms	1 (0.9%)
Nervous system disorders	
Dysgeusia	1 (0.9%)
Lethargy	1 (0.9%)
Paraesthesia	1 (0.9%)
Somnolence	1 (0.9%)

Table 2: Less Common Clinical Trial Adverse Drug Reactions (<2%) (continued)

System Organ Class Preferred Term	Overall (N=114)
Psychiatric disorders	
Confusional state	1 (0.9%)
Reproductive system and breast disorders	
Amenorrhoea	1 (0.9%)
Menstruation irregular	1 (0.9%)
Respiratory, thoracic and mediastinal disorders	
Dysphonia	1 (0.9%)
Oropharyngeal pain	1 (0.9%)
Throat irritation	1 (0.9%)
Vascular disorders	
Hot flush	1 (0.9%)

Abnormal Hematologic and Clinical Chemistry Findings

Table 3: Abnormal Hematologic and Clinical Chemistry Findings

Lab Test (Unit)	Patients with clinically significant abnormalities N (%)	Total Number of Clinically Significant Abnormalities	Mean (SD) of lab value	Mean Change (SD) from Lower Normal Limit	Mean Change (SD) from Upper Normal Limit
Alanine Aminotransferase (IU/L)	4 (4.0)	16	170.8 (50.92)		111.7 (48.15)
Aspartate Aminotransferase (IU/L)	4 (4.0)	15	98.5 (40.51)		56.9 (38.57)
Bicarbonate (mmol/L)	3 (3.0)	3	12.7 (1.53)	-9.3 (1.53)	
Glucose (mmol/L)	2 (2.6)	5	8.1 (2.13)		2.6 (2.13)
Potassium (mmol/L)	2 (2.0)	4	4.3 (1.48)	-0.7 (0.21)	0.3 (0.00)
Albumin (g/L)	2 (2.0)	2	32.4 (8.98)	-8.0 (NA)	
Lymphocytes (10 ⁹ /L)	2 (2.0)	2	1.3 (0.21)	-0.3 (0.21)	

Post-Market Adverse Drug Reactions

The serious adverse reactions are metabolic acidosis and pulmonary edema.

The non-serious adverse drug reactions are breath odor and urine odor abnormal.

DRUG INTERACTIONS

Overview

In vitro, PBA inhibited CYP2C9, CYP2D6 and CYP3A4/5. However, CYP3A4/5 showed differential inhibition by PBA, where metabolism of testosterone was inhibited, but metabolism

of midazolam was not. PAA inhibited all of the tested CYPs, which included CYP1A2, CYP2C8, CYP2C9, CYP2C19, CYP2D6 and both of CYP3A4/5 activities.

RAVICTI and/or its metabolites, PAA and PBA, have been shown to be weak inducers of CYP3A4 enzyme *in vivo*.

Drug-Drug Interactions

Table 4: Established or Potential Drug-Drug Interactions

Proper name	Ref	Effect	Clinical comment
Midazolam	CT	Increased rate of metabolism, ~32% decrease in midazolam AUC	RAVICTI is a weak inducer of CYP3A4.
Probenecid	T	May increase plasma PAA and PAGN	May inhibit the renal excretion of metabolites of RAVICTI including PAGN.
Corticosteroids	T	Use of corticosteroids may cause the breakdown of body protein and increase plasma ammonia levels	Monitor ammonia levels closely when corticosteroids and RAVICTI are used concomitantly
Valproic acid	T	Hyperammonemia may be induced	Monitor ammonia levels closely when use of valproic acid is necessary in UCD patients.
Haloperidol	T	Hyperammonemia may be induced	Monitor ammonia levels closely when use of haloperidol is necessary in UCD patients.

Legend: CT=clinical trial; T=theoretical; AUC=area under the curve; PAA=phenylacetate/phenylacetic acid; PAGN= phenylacetylglutamine; UCD=urea cycle disorder

Drug-Food Interactions

Interactions with food have not been established.

Drug-Herb Interactions

Interactions with herbal products have not been established.

Drug-Laboratory Interactions

Interactions with laboratory tests have not been established.

DOSAGE AND ADMINISTRATION

Dosing Considerations

RAVICTI should be prescribed by a physician experienced in the management of UCDs.

RAVICTI must be combined with dietary protein restriction and, in some cases, dietary supplements (essential amino acids, carnitine supplementation, arginine, citrulline, and protein-free calorie supplements).

The daily dose should be individually adjusted according to the patient's estimated urea synthetic capacity, if any, protein tolerance and the daily dietary protein intake needed to promote growth and development. An initial estimated RAVICTI dose for a 24-hour period is 0.6 mL RAVICTI per gram of dietary protein ingested per 24 hour period assuming all the waste nitrogen is covered by RAVICTI and excreted as PAGN.

Recommended Dose and Dosage Adjustment

The recommended total daily dose range of RAVICTI is 4.5 mL/m²/day to 11.2 mL/m²/day (5.0 g/m²/day to 12.4 g/m²/day) and should take into account the following:

- The total daily dose should be divided into equal amounts and given with each meal or feeding (e.g. three times to six times per day).
- Each rounded up to the nearest 0.5 mL.

The recommended starting dosages for patients switching from sodium phenylbutyrate to RAVICTI and patients naïve to PBA may be different.

Patients switching from sodium phenylbutyrate to RAVICTI should receive the dosage of RAVICTI that contains the same amount of PBA. The conversion is as follows:

Total daily dosage of RAVICTI (mL) = total daily dosage of sodium phenylbutyrate Tablets (g) x 0.86

Total daily dosage of RAVICTI (mL) = total daily dosage of sodium phenylbutyrate Powder (g) x 0.81

Adjustment Based on Plasma Ammonia: Adjust the RAVICTI dosage to produce a fasting plasma ammonia level that is less than half the upper limit of normal (ULN) in patients 6 years and older. In infants and young children (generally below 6 years of age) where obtaining fasting ammonia is problematic due to frequent feedings, the first ammonia of the morning should be used.

Adjustment Based on Urinary Phenylacetylglutamine: U-PAGN measurements may be used to help guide RAVICTI dose adjustment. Each gram of U-PAGN excreted over 24 hours covers waste nitrogen generated from 1.4 grams of dietary protein. If U-PAGN excretion is insufficient to cover daily dietary protein intake and the fasting ammonia is greater than half the recommended ULN, the RAVICTI dose should be adjusted upward. The amount of dose adjustment should factor in the amount of dietary protein that has not been covered, as indicated by the 24-h U-PAGN level and the estimated RAVICTI dose needed per gram of dietary protein ingested.

Adjustment Based on Plasma PAA and PAGN: If symptoms of vomiting, nausea, headache, somnolence, confusion, or sleepiness, are present in the absence of high ammonia or intercurrent illness, measurement of plasma PAA levels may be useful to guide dosing (see WARNINGS AND PRECAUTIONS, *Neurologic*). The ratio of PAA to PAGN in plasma, both measured in µg/mL, may provide additional information to assist in dose adjustment decisions. The PAA to PAGN ratio has been observed to be generally less than 1 in patients without PAA accumulation. In patients with a PAA to PAGN ratio exceeding 2.5, a further increase in RAVICTI dose may not increase PAGN formation, even if plasma PAA concentrations are increased, due to saturation of the conjugation reaction.

Dosage Modifications in Patients with Hepatic Impairment

For patients with moderate to severe hepatic impairment, the recommended starting dosage is at the lower end of the range.

Missed Dose

In the event a dose is missed, the dose should be taken as soon as the patient remembers. If it is close to the patient's next dose, skip the missed dose and continue with the next scheduled dose. The dose should not be doubled to make up for the missed dose.

Administration

For oral administration.

RAVICTI should be taken with food and administered directly into the mouth via oral syringe.

Preparation for Nasogastric Tube or Gastrostomy Tube Administration

In vitro studies evaluating the percent recovery of total dose delivered with nasogastric or gastrostomy tubes demonstrated the percent of dose recovered was >99% for doses >1 mL and 70% for a 0.5 mL dose.

It is recommended that all patients who can swallow take RAVICTI orally, even those with nasogastric and/or gastric tubes. However, for patients who cannot swallow, a nasogastric tube or gastrostomy tube may be used to administer RAVICTI as follows:

- Utilize an oral syringe to withdraw the prescribed dosage of RAVICTI from the bottle.
- Place the tip of the syringe into the tip of the gastrostomy/nasogastric tube.
- Administer RAVICTI into the tube.
- Flush with at least 10 mL of water or formula.

OVERDOSAGE

While there is no experience with overdosage in human clinical trials, PAA, a toxic metabolite of RAVICTI, can accumulate in patients who receive an overdose.

For management of a suspected drug overdose, contact your regional Poison Control Centre.

ACTION AND CLINICAL PHARMACOLOGY

Mechanism of Action

UCDs are inherited deficiencies of enzymes or transporters necessary for the synthesis of urea from ammonia (NH_3 , NH_4^+). Absence of these enzymes or transporters results in the accumulation of toxic levels of ammonia in the blood and brain of affected patients. RAVICTI is a triglyceride containing 3 molecules of PBA. PAA, the major metabolite of PBA, is the active moiety of RAVICTI. PAA conjugates with glutamine (which contains 2 molecules of nitrogen) via acetylation in the liver and kidneys to form PAGN, which is excreted by the kidneys (Figure 1). On a molar basis, PAGN, like urea, contains 2 moles of nitrogen and provides an alternate vehicle for waste nitrogen excretion.

Figure 1: RAVICTI Mechanism of Action

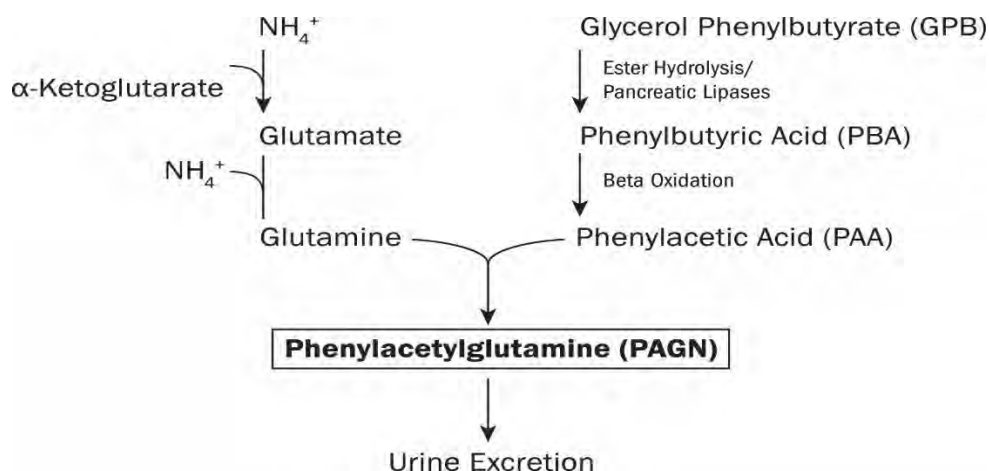

Pharmacodynamics

Pharmacological Effects: Blood ammonia was the pharmacodynamics efficacy surrogate in each of the short term studies. In the combined pooled analysis of these short-term studies, daily average ammonia was 31 $\mu\text{mol/L}$ in 80 adult and pediatric UCD patients during treatment with RAVICTI.

Cardiac Electrophysiology: A double-blind, randomized, placebo- and active-controlled, 4-arm crossover ECG assessment study was performed in healthy subjects (N=57). Each subject received 4 treatments in a randomly assigned sequence: RAVICTI 4.4 g TID, RAVICTI 6.6 g TID, placebo, and a positive control, each for 3 days. The 4.4 g TID and 6.6 g TID doses corresponded to average doses of 6.55 $\text{g/m}^2/\text{day}$ and 9.62 $\text{g/m}^2/\text{day}$, respectively, which are within the therapeutic dose range. Serial ECG data were collected on day 3 of treatment between 0.5 and 23 hours after administration of the first of the TID doses.

RAVICTI resulted in a dose- and concentration-dependent increase in heart rate. At the 4.4 g TID dose, statistically significant ($p < 0.05$) positive mean differences from placebo were observed at 4 of 12 time points on day 3, with a maximum mean difference from placebo of 4.6 bpm (90% CI 3.0, 6.3) at the 12 h time point. At the 6.6 g TID dose, statistically significant positive mean differences from placebo were observed at 9 of 12 time points on day 3, with a maximum mean difference from placebo of 10.6 bpm (90% CI 8.3, 12.8) at the 16 h time point.

RAVICTI was also associated with QTcF ($\text{QTcF} = \text{QT}/\text{RR}^{0.33}$) shortening. At the 4.4 g TID dose, statistically significant negative mean differences from placebo were observed at 9 of 12 time points on day 3, with a maximum mean difference from placebo of -7.2 ms (90% CI -10.1, -4.3) at the 16 h time point. At the 6.6 g TID dose, statistically significant negative mean differences from placebo were observed at 11 of 12 time points on day 3, with a maximum mean difference from placebo of -6.9 ms (90% CI -9.4, -4.4) at the 16 h time point.

Pharmacokinetics

Absorption: RAVICTI is a pro-drug of PBA. Upon oral ingestion, PBA is released from the glycerol backbone in the gastrointestinal tract by lipases. PBA derived from RAVICTI is further converted by β -oxidation to PAA.

In adult UCD patients receiving multiple doses of RAVICTI, the time to achieve the maximum plasma concentrations at steady state ($T_{\max-ss}$) of PBA, PAA, and PAGN occurred at 8 h, 12 h, and 10 h, respectively, after the first dose in the day. In pediatric UCD patients receiving multiple doses of RAVICTI, the time to achieve the $T_{\max-ss}$ occurred at 8h, for all metabolites, after the first dose in the day. The AUC_{0-24} ($\mu\text{g}\cdot\text{h}/\text{mL}$) for PBA in adult UCD patients was 433 and for pediatric patients was 420 respectively. The AUC_{0-24} ($\mu\text{g}\cdot\text{h}/\text{mL}$) for PAA in adult UCD patients was 447 and for pediatric patients was 1038 respectively. The AUC_{0-24} ($\mu\text{g}\cdot\text{h}/\text{mL}$) for PAGN in adult UCD patients was 1127 and for pediatric patients was 1239, respectively. In adult UCD patients receiving multiple doses of RAVICTI mean maximum concentration (C_{\max}) for PBA, PAA, and PAGN was 51.9 $\mu\text{g}/\text{mL}$, 38.5 $\mu\text{g}/\text{mL}$, and 78.6 $\mu\text{g}/\text{mL}$, respectively. In pediatric UCD patients receiving multiple doses of RAVICTI mean C_{\max} for PBA, PAA, and PAGN was 62.7 $\mu\text{g}/\text{mL}$, 87.3 $\mu\text{g}/\text{mL}$, and 93.9 $\mu\text{g}/\text{mL}$, respectively. Total 24-hr urinary PAGN excretion in adult and pediatric UCD patients were 12.9 and 12.5 g, respectively.

Distribution: *In vitro*, the extent of plasma protein binding for ^{14}C -labeled metabolites was 80.6% to 98.0% for PBA (over 1-250 $\mu\text{g}/\text{mL}$), and 37.1% to 65.6% for PAA (over 5-500 $\mu\text{g}/\text{mL}$). The protein binding for PAGN was 7% to 12% and no concentration effects were noted.

Metabolism: Upon oral administration, pancreatic lipases hydrolyze RAVICTI (i.e., glycerol phenylbutyrate), and release PBA. PBA undergoes β -oxidation to PAA, which is conjugated with glutamine in the liver and in the kidney through the enzyme phenylacetyl-CoA: L-glutamine-N-acetyltransferase to form PAGN. PAGN is subsequently eliminated in the urine.

Saturation of conjugation of PAA and glutamine to form PAGN was suggested by increases in the ratio of plasma PAA to PAGN with increasing dose and with increasing severity of hepatic impairment.

In *in vitro* studies, the specific activity of lipases for glycerol phenylbutyrate was in the following decreasing order: pancreatic triglyceride lipase, carboxyl ester lipase, and pancreatic lipase-related protein 2. Further, glycerol phenylbutyrate was hydrolyzed *in vitro* by esterases in human plasma. In these *in vitro* studies, a complete disappearance of glycerol phenylbutyrate did not produce molar equivalent PBA, suggesting the formation of mono- or bis-ester metabolites. However, the formation of mono- or bis-esters was not studied in humans.

Excretion: The mean (SD) percentage of administered PBA excreted as PAGN ranged from approximately 60-70% and averaged 68.9% (17.2) in adults and 66.4% (23.9) in pediatric UCD patients at steady state. PAA and PBA represented minor urinary metabolites, each accounting for <1% of the administered dose of PBA.

Special Populations and Conditions

Pediatrics: Population pharmacokinetic modeling and dosing simulations suggest body surface area to be the most significant covariate explaining the variability of PAA clearance. PAA clearance was 10.9 L/h, 16.4 L/h, and 24.4 L/h, respectively, for UCD patients ages 3 to 5, 6 to 11, and 12 to 17 years.

Gender: In healthy adult volunteers, a gender effect was found for all metabolites, with women generally having higher plasma concentrations of all metabolites than men at any given dose level. In healthy female volunteers, mean C_{\max} for PAA was 51 and 120% higher than in male

volunteers after administration of 4 mL and 6 mL 3 times daily for 3 days, respectively. The dose normalized mean AUC_{0-23h} for PAA was 108% higher in females than in males.

Hepatic Insufficiency: No studies were conducted in UCD patients with hepatic impairment, although glycerol phenylbutyrate has been administered to over 100 patients with cirrhosis. Because conversion of PAA to PAGN occurs in the liver, patients with severe hepatic impairment may have reduced conversion capability and higher plasma PAA and plasma PAA to PAGN ratio. Therefore, dosage for patients with moderate to severe hepatic impairment should be started at the lower end of the recommended dosing range and should be kept on the lowest dose necessary to control their ammonia levels. A plasma PAA to PAGN ratio exceeding 2.5 may indicate saturation of PAA to PAGN conversion capacity and the need for reduced dosing.

Renal Insufficiency: The pharmacokinetics of RAVICTI in patients with impaired renal function, including those with end-stage renal disease (ESRD) or those on hemodialysis have not been studied.

STORAGE AND STABILITY

Store at 15-30°C.

Keep in original packaging to protect from light.

Use the contents of the bottle within 90 days after opening.

DOSAGE FORMS, COMPOSITION AND PACKAGING

RAVICTI is a colourless to pale yellow oral liquid. The dosage strength is 1.1 g/mL glycerol phenylbutyrate (delivers 1.02 g/mL of PBA). There are no excipients.

RAVICTI is supplied in multi-use, 25-mL glass bottles. The bottles are supplied in the following configurations:

- Single 25-mL bottle per carton
- Four 25-mL bottles per carton

PART II: SCIENTIFIC INFORMATION

PHARMACEUTICAL INFORMATION

Drug Substance

Proper name: RAVICTI

Common name: glycerol phenylbutyrate

Chemical name: benzenebutanoic acid, 1', 1''-(1,2,3-propanetriyl) ester

Molecular formula and molecular mass: C₃₃H₃₈O₆, 530.67

Structural formula:

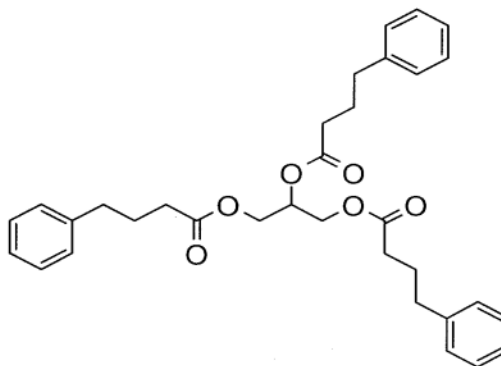

Physicochemical properties: RAVICTI (glycerol phenylbutyrate) is a clear, colorless to pale yellow oral liquid. It is insoluble in water and most organic solvents, and it is soluble in dimethylsulfoxide (DMSO) and >65% acetonitrile.

Glycerol phenylbutyrate is a nitrogen-binding agent. It is a triglyceride containing 3 molecules of PBA linked to a glycerol backbone. The pH cannot be accurately determined due to the absence of any ionizable functional groups in the molecular structure.

CLINICAL TRIALS

Study demographics and trial design

The effectiveness of RAVICTI in controlling ammonia in patients with UCDs was evaluated in 114 UCD patients across four short-term switch-over (SO) controlled studies (1 to 2 week) and three long term studies (12 month). The short-term studies enrolled in 85 UCD patients (59 adult and 26 pediatric) and the long-term studies enrolled 100 UCD patients (51 adults and 49 pediatric). Most patients in the short term studies also participated in the long term studies. Demographic characteristics of the patient population are shown in Table 5.

HPN-100-003 (Study 003): was an open label, fixed-sequence, switch over study to compare control of blood ammonia on RAVICTI to sodium phenylbutyrate in 10 adult UCD patients (see Table 5) who were being treated with sodium phenylbutyrate for control of their UCD. Patients were enrolled and received sodium phenylbutyrate for 1 week and then switched to RAVICTI for 1 week. Each patient received sodium phenylbutyrate or RAVICTI TID with meals. The dose of RAVICTI was calculated to deliver the same amount of PBA as the dose of sodium phenylbutyrate. After 1 week of dosing with each treatment, all patients underwent 24 hours of ammonia measurements as well as blood and urine pharmacokinetic (PK). Dietary protein was controlled throughout the study.

HPN-100-006 (Study 006) : was a randomized, double-blind, double dummy, active-controlled, cross-over study to assess the non-inferiority of RAVICTI to sodium phenylbutyrate by evaluating blood ammonia in 45 adult UCD patients (see Table 5) who were being treated with sodium phenylbutyrate for control of their UCD. Each patient was randomized 1:1 to one of two treatment arms to receive either sodium phenylbutyrate/ RAVICTI placebo → sodium phenylbutyrate placebo/ RAVICTI or RAVICTI/sodium phenylbutyrate placebo → RAVICTI placebo/sodium phenylbutyrate for 4 weeks (2 weeks each on active sodium phenylbutyrate or RAVICTI). Each patient received sodium phenylbutyrate or RAVICTI three times a day (TID) with meals. The dose of RAVICTI was calculated to deliver the same amount of PBA as the sodium phenylbutyrate dose. After 2 weeks of dosing, by which time patients had reached steady state on each treatment, all patients underwent 24 hours of ammonia measurements. Dietary protein was controlled throughout the study. Upon completion of Study 006, patients were allowed to enroll into a separate long-term (12-month) open label study HPN-100-007 (Study 007).

Studies HPN-100-005 (Study 005) and HPN-100-012 (Study 012) were open label, fixed-sequence, switch over studies to compare control of blood ammonia on RAVICTI to sodium phenylbutyrate in 11 and 15 pediatric UCD patients, respectively (see Table 5). In each study, patients who were being treated with sodium phenylbutyrate for control of their UCD were enrolled and received sodium phenylbutyrate for 1 week and then switched to RAVICTI for 1 week. Each patient received sodium phenylbutyrate or RAVICTI TID with meals. The dose of RAVICTI was calculated to deliver the same amount of PBA as the dose of sodium phenylbutyrate. Three times or four times daily feeding and administration of RAVICTI was recommended; however, flexibility was allowed based on the subject's prior sodium phenylbutyrate dosing regimen and/or feeding habits. After 1 week of dosing with each treatment, all patients underwent 24 hours of ammonia measurements as well as blood and urine PK. Dietary protein was controlled throughout the study. Upon completion of switch-over part of each study, patients were allowed to continue receiving and new additional patients were allowed to enrol to receive RAVICTI for 12 months in an open label safety extension.

Table 5: Summary of Patient Demographics for Clinical Trials in Urea Cycle Disorders

Study #	Trial design	Dosage (Range), route of administration and duration	Study subjects, UCD subtype (n = number)	Mean age (Range) Years	Gender
N/A	Pooled long term population	11 (1-34) g/day	n=100 ARG: 2 ASL: 13 ASS: 12 CPS: 1 HHH: 3 OTC: 69	29 (0.2-60)	67% F
003	Open label, fixed sequence, switch over	13 (7-19) g/day oral 1 week	n=14 ASS: 1 HHH: 1 OTC: 8	36 (21-73)	60% F
006	Randomized, double blind, crossover	13 (2-34) g/day oral 2 weeks	n=45 ASS: 3 CPS: 2 OTC: 40	33 (18-75)	69% F
005	Open label, fixed sequence, switch over with 12 month safety extension	SO: 12 (8-19) g/day oral 1 week SE: 11 (2-19) g/day oral 12 months	SO: n=11 ASL: 1 ASS: 1 OTC: 9 SE: n=17 ASL: 1 ASS: 2 OTC: 14	SO: 10 (6-11) SE: 10 (6-11)	SO: 91% F SE: 82% F
007	Open label	13 (2-34) g/day oral 12 months	N=60 ARG: 1 ASL: 2 ASS: 4 CPS: 1 HHH: 3 OTC: 49	29 (6-60)	68% F
012	Open label, fixed sequence, switch over with 12 month safety extension	SO: 5 (1-9) g/day oral, 1 week SE: 5 (1-9) g/day oral 12 months	SO: 15 ARG: 1 ASL: 8 ASS: 3 OTC: 3 SE: 23 ARG: 1 ASL: 10 ASS: 6 OTC: 6	SO: 3 (0.2-5) SE: 3 (0.2-5)	SO: 53% F SE: 52% F

Legend: ARG=arginase; ASL=argininosuccinate lyase, ASS=argininosuccinate synthetase; CPS=carbaryl phosphate synthetase; f=female; HHH=ornithine translocase deficiency; m=month; N/A=not applicable; OTC=ornithine transcarbamylase; SO =switch over; SE=safety extension.

Study results

Clinical Studies in Adult Patients with UCDS

Short Term Efficacy in Adult UCD Patients

In the pooled analysis of the short-term studies in adults (Figure 2), mean daily ammonia level was 34 $\mu\text{mol/L}$ versus 40 $\mu\text{mol/L}$ on sodium phenylbutyrate ($p=0.136$ paired t-test) and glutamine level was 760 $\mu\text{mol/L}$ versus 807 $\mu\text{mol/L}$ on sodium phenylbutyrate during treatment with RAVICTI ($n=54$). The maximum PAA and PAGN concentrations achieved during treatment with RAVICTI were 38.5 $\mu\text{g/mL}$ and 78.6 $\mu\text{g/mL}$, respectively versus 91.5 $\mu\text{g/mL}$ and 86.3 $\mu\text{g/mL}$ on sodium phenylbutyrate, respectively.

Figure 2: Venous Ammonia Response in Adult UCD Patients in Short-Term Treatment

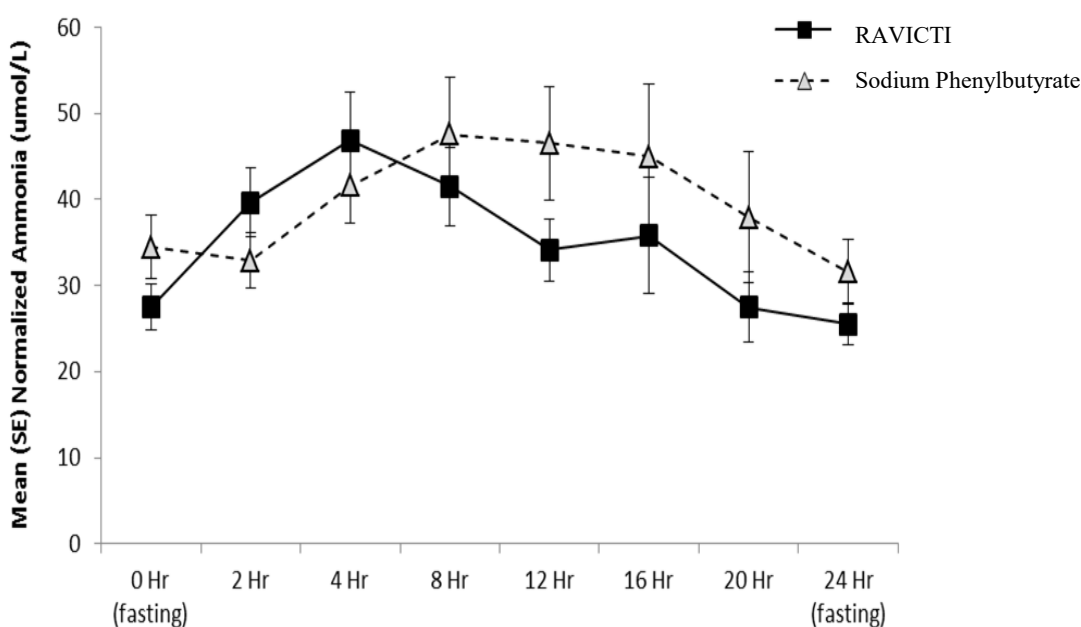

Long Term Efficacy in Adult UCD Patients

A long-term (12-month), uncontrolled, open-label study (Study 007) was conducted to assess monthly ammonia control and hyperammonemic crisis over a 12-month period. A total of 51 adults were in the study and all but 6 had been converted from sodium phenylbutyrate to RAVICTI. Venous ammonia levels were monitored monthly. Mean fasting venous ammonia values in adults were within normal limits during long-term treatment with RAVICTI (range: 6-30 $\mu\text{mol/L}$).

In long-term studies, the median (25-75 percentiles) levels of PBA, PAA and PAGN obtained from 195 samples in 51 adult patients were 0.5 (0.5-2.78) $\mu\text{g/mL}$, 1.12 (0.5-4.17) $\mu\text{g/mL}$, and 14.28 (4.64-28.15) $\mu\text{g/mL}$, respectively. Of 51 adult patients participating in the 12-month, open-label treatment with RAVICTI, 7 patients (14%) reported a total of 10 hyperammonemic crises versus 15 crises in 9 (18%) patients in the preceding 12 months prior to study entry, in patients receiving sodium phenylbutyrate. The fasting venous ammonia measured during Study 007 is

displayed in Figure 3. Ammonia values across different laboratories were normalized to a common normal range of 9 to 35 $\mu\text{mol/L}$.

Figure 3: Venous Ammonia Response in Adult UCD Patients in Long-Term Treatment

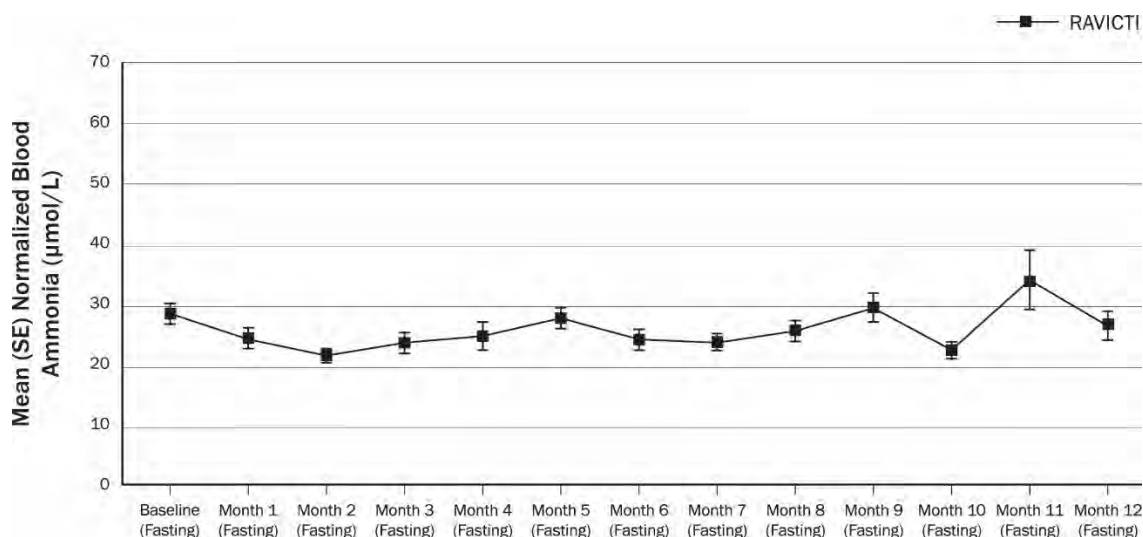

Clinical Studies in Pediatric Patients with UCDS

Short Term Efficacy in Pediatric UCD Patients

In the pooled analysis (Figure 4) of the short-term studies in children (005 and 012), mean daily ammonia level was 24 $\mu\text{mol/L}$ versus 35 $\mu\text{mol/L}$ on sodium phenylbutyrate ($p=0.007$; paired t-test) and glutamine level was 661 $\mu\text{mol/L}$ versus 710 $\mu\text{mol/L}$ on sodium phenylbutyrate during treatment with RAVICTI ($N=26$). Four patients <2 years of age are excluded for this analysis due to insufficient data. The maximum PAA and PAGN concentration achieved during treatment with RAVICTI were 87.3 $\mu\text{g/mL}$ and 93.9 $\mu\text{g/mL}$, versus 50.2 $\mu\text{g/mL}$ and 74.6 $\mu\text{g/mL}$ on sodium phenylbutyrate, respectively.

Neuropsychological function was assessed as an exploratory endpoint at baseline and at the end of long-term treatment using BRIEF (Behavior Rating Inventory of Executive Function), CBCL (Child Behavior Checklist) and WASI (Wechsler Abbreviated Scale of Intelligence). CBCL and WASI scores remained stable while mean (SD) of T score in global executive composite of BRIEF improved significantly from 66.2 (14.02) at baseline to 56.5 (9.71) at the end of study.

Figure 4: Venous Ammonia Response in Pediatric UCD Patients in Short-Term Treatment

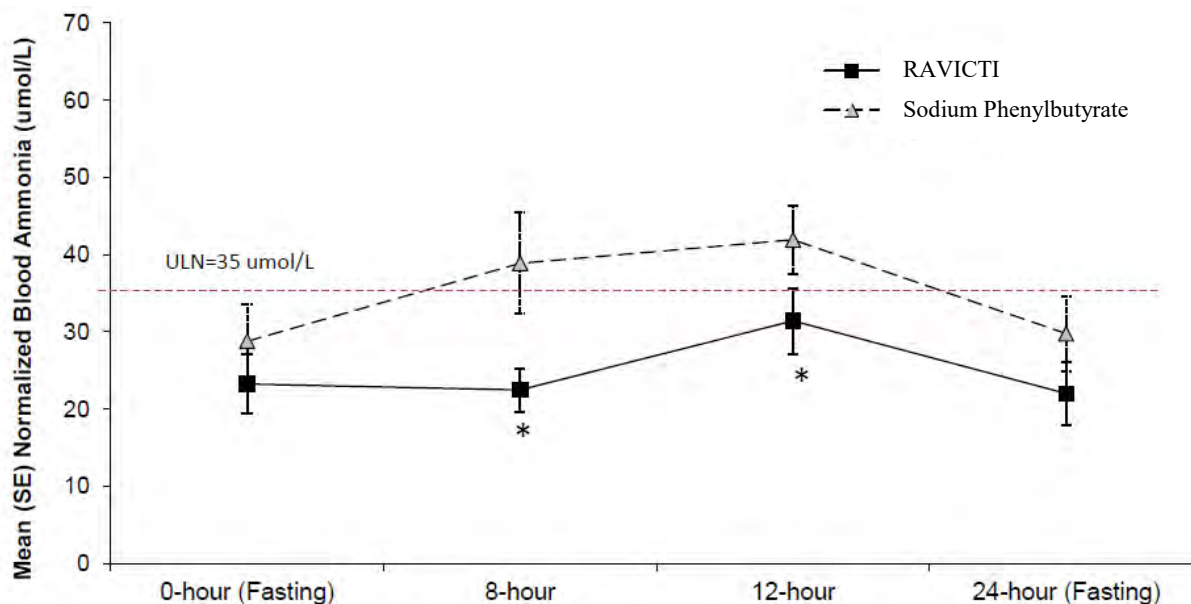

Long Term Efficacy in Pediatric UCD Patients

Long-term (12-month), uncontrolled, open-label studies were conducted to assess monthly ammonia control and hyperammonemic crisis over a 12-month period in three studies (Study 007, which also enrolled adults, extension of Study 005 and extension study 012). A total of 49 children ages 2 month to 17 years were enrolled, and all but 1 had been converted from sodium phenylbutyrate to RAVICTI. The fasting venous ammonia measured during these long-term studies in patients 2 years to 17 years is displayed in Figure 5 (range:17-25 $\mu\text{mol/L}$). Ammonia values across different laboratories were normalized to a common normal range of 9 to 35 $\mu\text{mol/L}$.

In long-term studies, the median (25-75 percentiles) levels of PBA, PAA and PAGN obtained from 250 samples in 49 pediatric patients were 2.07 (0.5-8.7) $\mu\text{g/mL}$, 2.95 (0.5-31.19) $\mu\text{g/mL}$, and 21.18 (7.14-52.56) $\mu\text{g/mL}$, respectively. Of the 49 pediatric patients treated with RAVICTI for up to 12 months, 12 patients (24.5%) reported a total of 17 hyperammonemic crises versus 38 crises in 21 (42.9%) patients in the preceding 12 months prior to study entry, in patients receiving sodium phenylbutyrate.

Figure 5: Venous Ammonia Response in Pediatric UCD Patients in Long-Term Treatment

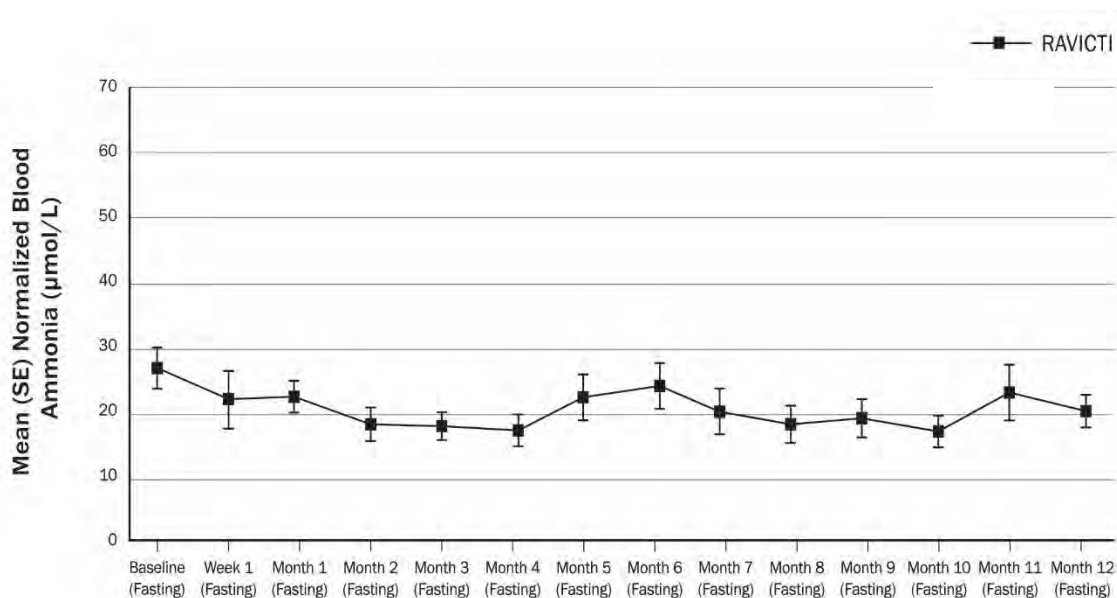

DETAILED PHARMACOLOGY

Nonclinical Pharmacology

The nonclinical pharmacokinetics and toxicology studies established that glycerol phenylbutyrate was not detected in plasma, indicating that PBA is released from glycerol phenylbutyrate in the gastrointestinal tract and is subsequently converted systemically to PAA, the active molecule. Results of *in vitro* studies have shown that digestive lipases are the main enzymes responsible for hydrolysis of glycerol phenylbutyrate.

In a study in male monkeys, the average bioavailability of PBA following oral administration of glycerol phenylbutyrate was 67% (51-80%) with a mean T_{max} of 8 h, which may reflect the need to hydrolyze the ester functionality within the molecule prior to absorption. Concentrations of known metabolites PBA, PAA, and PAGN (representing about 30% of the administered dose) were quantifiable in the plasma of all three monkeys at 1.5 h postdose. Following a single oral dose of radiolabeled glycerol phenylbutyrate to male monkeys, radioactivity was widely distributed throughout the body. Tissue concentrations were highest in the large intestine wall, bile, plasma, kidney, liver, urinary bladder, and whole blood.

Systemic metabolites of glycerol phenylbutyrate are excreted primarily via the urine following oral administration to rats and primates. In primates and humans, the major pathway for excretion in urine is in the form of phenylacetyl glutamine which results from conjugation of PAA with glutamine, while in other animals, including rat, rabbit, and mouse, PAA is excreted in the urine conjugated with glycine.

Clinical Pharmacology

In human studies, PBA, PAA and PAGN were the major plasma metabolites and PAGN the major urinary metabolite. An average of 60-70% of the PBA delivered as glycerol phenylbutyrate was excreted in urine as PAGN, consistent with 60-70% bioavailability. PopPK

modeling further indicated that PBA enters the circulation slowly when delivered orally as glycerol phenylbutyrate and that the rate of PAA to PAGN conversion varies directly with body surface area, resulting in a higher PAA exposure among young children as compared with adults for equivalent dosing.

TOXICOLOGY

Acute toxicity

Following a single oral administration, the minimum lethal dose of glycerol phenylbutyrate was 1200 mg/kg in rats and greater than 6500 mg/kg in monkeys.

Repeated dose toxicity

Repeat-dose oral toxicity studies were conducted in mice, rats and monkeys for up to 13, 26, and 52 weeks, respectively. Clinical signs of central nervous system (CNS) effects (e.g., hypoactivity, impaired equilibrium, or impaired muscle coordination) were observed in all species studied. In a 13-week repeat-dose study in juvenile monkeys, clinical observations of inappetence, tremors, hypoactivity, impaired equilibrium, twitching, body pallor, and labored respiration were observed at doses of ≥ 1250 mg/kg/day (≥ 2 times the clinical dose of 8.195 g/m²/day in pediatric patients, based on combined AUCs for PBA and PAA).

Histopathological changes in the liver (centrilobular hepatocellular hypertrophy) and spleen (hemosiderosis and lymphoid depletion) were observed in rats and monkeys following chronic dosing with glycerol phenylbutyrate. The no-observed-adverse-effect levels (NOAELs) in the 26-week rat and 52-week monkey studies were below 650 mg/kg/day and 750 mg/kg/day (< 3.2 times and < 2 times the dose of 7.557 g/m²/day in adult patients, based on the combined AUCs for PBA and PAA), respectively. The NOAEL in the 13-week study in juvenile monkeys was below 750 mg/kg/day (< 1.2 times the dose of 8.195 g/m²/day in pediatric patients, based on combined AUCs for PBA and PAA, respectively).

Carcinogenesis

In a 2-year carcinogenicity study in rats, glycerol phenylbutyrate caused a statistically significant increase in the incidence of pancreatic acinar cell adenoma, carcinoma, and combined adenoma or carcinoma at a dose of 650 mg/kg/day in males (3.4 times the dose of 7.557 g/m²/day in adult patients, based on combined AUCs for PBA and PAA) and 900 mg/kg/day in females (8.4 times the dose of 7.557 g/m²/day in adult patients, based on combined AUCs for PBA and PAA). The incidence of the following tumors was also increased in female rats at a dose of 900 mg/kg/day: thyroid follicular cell adenoma, carcinoma and combined adenoma or carcinoma, adrenal cortical combined adenoma or carcinoma, uterine endometrial stromal polyp, and combined polyp or sarcoma. The dose of 650 mg/kg/day in male rats is 2.1 times the dose of 8.195 g/m²/day in pediatric patients, based on combined AUCs for PBA and PAA. The dose of 900 mg/kg/day in female rats is 5.1 times the dose of 8.195 g/m²/day in pediatric patients, based on combined AUCs for PBA and PAA. In a 26-week study in transgenic (Tg.rasH2) mice, glycerol phenylbutyrate was not tumorigenic at doses up to 1000 mg/kg/day.

Mutagenesis

Glycerol phenylbutyrate was not genotoxic in the Ames test, the *in vitro* chromosomal aberration test in human peripheral blood lymphocytes, or the *in vivo* rat micronucleus test. The metabolites

PBA, PAA, PAGN, and phenylacetyl glycine were not genotoxic in the Ames test or *in vitro* chromosome aberration test.

Reproductive toxicity

Glycerol phenylbutyrate administered orally before cohabitation and through mating and implantation had no effect on fertility or reproductive function in male and female rats at oral doses up to 900 mg/kg/day (approximately 5.9 times the dose of 7.557 g/m²/day in adult patients, based on combined AUCs for PBA and PAA). A higher dose of 1200 mg/kg/day to males was associated with lower fetal viability in both treated and untreated females. A significant reduction in sperm count in the caudal epididymis of male rats also occurred at 1200 mg/kg/day (approximately 6.4 times the dose of 7.557 g/m²/day in adult patients, based on combined AUCs for PBA and PAA).

In embryo-fetal development studies, glycerol phenylbutyrate was administered orally to pregnant rats and rabbits during the period of organogenesis. In rats, decreased fetal body weight, increased incidence of malformations (absent, short, or thread-like tail) and skeletal variations (supernumerary ribs and thickened ribs), and ossification delay were observed at doses of ≥650 mg/kg/day (≥5.7 times the dose of 7.557 g/m²/day in adult patients, based on combined AUCs for PBA and PAA) in the presence of maternal toxicity. Neither maternal nor developmental toxicities were observed in rabbits up to the highest dose of 350 mg/kg/day. The developmental NOAELs were 300 and 350 mg/kg/day for rats and rabbits, or approximately 1.9 and 2.7 times the dose of 7.557 g/m²/day in adult patients (based on combined AUCs for PBA and PAA), respectively.

In a pre- and postnatal development study, pregnant rats received oral doses of 300, 600, and 900 mg/kg/day glycerol phenylbutyrate from gestation day 7 through lactation day 20 (weaning). Maternal toxicity (reduced body weights and food consumption) was evident at 600 and 900 mg/kg/day. A slight increase in the duration of gestation was noted in dams receiving 900 mg/kg/day (approximately 7.4 times the dose of 7.557 g/m²/day in adult patients, based on combined AUCs for PBA and PAA). Other than reduced pup body weights throughout the preweaning period in the 900 mg/kg/day group, there were no adverse effects on sexual maturation, learning and memory and reproductive capacity of the F₁ generation. The NOAEL for reproduction in the dams and for growth of F₁ pups was 600 mg/kg/day (approximately 5.7 times the dose of 8.195 g/m²/day in adult patients, based on combined AUCs for PBA and PAA).

In a juvenile toxicity study, glycerol phenylbutyrate was administered to male and female rats from postpartum day 2 through mating and gestation at oral doses of 650, 900 and 1200 mg/kg/day. Terminal body weights were significantly reduced by more than 10% in both males and females at 900 and 1200 mg/kg/day. Learning, memory, and motor activity endpoints were not affected. However, fertility (number of pregnant rats) was decreased by up to 27% at ≥650 mg/kg/day. Embryo-fetal toxicity (increased post-implantation loss and decreased fetal body weight) occurred at doses of ≥650 mg/kg/day and teratogenicity (absent or thread-like tail and umbilical hernia) was observed at doses of ≥900 mg/day (≥3 times the dose of 7.557 g/m²/day in adult patients, based on combined AUCs for PBA and PAA). The NOAEL for general toxicity in the neonatal/juvenile rats was 650 mg/kg/day (approximately 1.6 times the dose of 8.195 g/m²/day in pediatric patients, based on combined AUCs for PBA and PAA). The NOAELs for fertility and embryo-fetal development were below 650 mg/kg/day (<2.6 times the dose of 7.557 g/m²/day in adult patients, based on combined AUCs for PBA and PAA).

READ THIS FOR SAFE AND EFFECTIVE USE OF YOUR MEDICINE

PATIENT MEDICATION INFORMATION

Pr **RAVICTI**[™]

(glycerol phenylbutyrate) Oral Liquid

Read this carefully before you start taking **RAVICTI** and each time you get a refill. This leaflet is a summary and will not tell you everything about this drug. Talk to your healthcare professional about your medical condition and treatment and ask if there is any new information about **RAVICTI**.

What is RAVICTI used for?

RAVICTI (rah-VIK-tee) is a prescription medicine used in adults and children 2 years of age and older for long-term management of high blood levels of ammonia (hyperammonemia) caused by a condition called Urea Cycle Disorder (UCD). **RAVICTI** should be used if the UCD cannot be managed with a low protein diet and dietary supplements alone. **RAVICTI** must be used along with a low protein diet and in some cases dietary supplements.

RAVICTI should only be prescribed by a healthcare professional experienced in the treatment of UCDs.

RAVICTI is not to be used to treat acute (severe) high blood levels of ammonia in patients with UCDs.

It is not known if **RAVICTI** is safe and effective for the treatment of *N*-acetylglutamate synthase (NAGS) deficiency.

RAVICTI is not to be used in children less than 2 months of age. It is not known if **RAVICTI** is safe and effective in children between the ages of 2 months and 2 years.

How Does RAVICTI Work?

Patients with UCD are unable to get rid of ammonia that is normally produced in the body. **RAVICTI** works by helping the body to remove excess ammonia.

What are the ingredients in RAVICTI?

Medicinal ingredients: glycerol phenylbutyrate

Non-medicinal ingredients: none

RAVICTI comes in the following dosage forms:

Oral liquid, 1.1 g/mL

Do not use RAVICTI if:

- Children are less than 2 months of age.
- You are experiencing acute hyperammonemia.

- You are allergic to glycerol phenylbutyrate, phenylbutyric acid (PBA), phenylacetic acid (PAA), and/or phenylacetylglutamine (PAGN).
- You are breastfeeding.

To help avoid side effects and ensure proper use, talk to your healthcare professional before you take RAVICTI. Talk about any health conditions or problems you may have, including if you:

- have liver or kidney problems
- have heart problems
- have pancreas or bowel (intestine) problems
- are pregnant or plan to become pregnant. It is not known if RAVICTI will harm your unborn baby.

While taking RAVICTI it is still possible to develop an acute episode of excess ammonia in your blood. **This is a medical emergency, and medical assistance should be sought immediately.** Symptoms may include nausea, vomiting, confusion, combativeness, slurred speech, difficulty walking, and even loss of consciousness. An infection can cause an episode of excess ammonia; therefore, if you develop a fever you should seek prompt medical assistance.

Tell your healthcare professional about all the medicines you take, including any drugs, vitamins, minerals, natural supplements or alternative medicines.

The following medicines may change the effect of RAVICTI and you may need more frequent blood tests:

- **Midazolam, corticosteroids, barbiturates, topiramate, carbamazepine some immunosuppressive and anti-cancer drugs.**
- **Probenecid:** May interfere with the removal of RAVICTI from the body.
- **Corticosteroids:** Use of corticosteroids may cause the breakdown of body protein and increase ammonia levels in your blood.
- **Valproic Acid and Haloperidol:** May cause high blood ammonia.

How to take RAVICTI:

Usual dose:

The daily dose of RAVICTI will be based on your body surface area and should be adjusted based on your protein tolerance and diet.

- The daily dose range of RAVICTI is 4.5 – 11.2 mL/m²/day.
- The total daily dose should be divided into equal amounts and given with each meal or feeding.
- Each dose should be rounded up to the nearest 0.5 mL.
- RAVICTI should be taken by mouth using an oral syringe that is provided to you by your pharmacist.

- You will need regular blood tests to determine the correct daily dose.
- Take RAVICTI exactly as your doctor tells you.
- Stay on the diet that your doctor gives you.

For people who have a nasogastric or gastric tube in place, RAVICTI should be given as follows:

- It is recommended that all patients who can swallow take RAVICTI orally, even those with nasogastric and/or gastric tubes.
- For patients who cannot swallow, a nasogastric or gastric tube can be used to administer RAVICTI as follows:
 - Use an oral syringe to take the prescribed dose of RAVICTI from the bottle.
 - Place the tip of the syringe into the tip of the nasogastric or gastric tube and administer RAVICTI into the tube.
 - Flush the nasogastric or gastric tube with at least 10 mL of water or formula.

Overdose:

If you think you have taken too much RAVICTI, contact your healthcare professional, hospital emergency department or regional Poison Control Centre immediately, even if there are no symptoms.

Missed Dose:

If you missed a dose of this medication, take it as soon as you remember. But if it is almost time for your next dose, skip the missed dose and continue with your next scheduled dose. Go back to the regular dosing schedule. Do not take two doses at the same time.

What are possible side effects from using RAVICTI?

These are not all the possible side effects you may feel when taking RAVICTI. If you experience any side effects not listed here, contact your healthcare professional.

The most common side effects include diarrhea, gas, headache, decreased appetite, vomiting, nausea, fatigue and skin odor.

Other side effects that may occur include:

- Stomach pain and discomfort, constipation, indigestion
- Dizziness
- Tremor
- Irregular menstrual bleeding
- Acne

RAVICTI can cause abnormal blood test results. Your healthcare professional will decide when to perform blood tests.

Serious side effects and what to do about them

Symptom / effect	Talk to your healthcare professional		Get immediate medical help
	Only if severe	In all cases	
RARE Neurotoxicity (nervous system side effects): Sleepiness, weakness, lightheadedness, change in taste, problems with hearing, confusion, problems with memory, worsening neuropathy (numbness, tingling, or burning in your hands or feet), headache			√
Allergic Reaction: rash, hives, swelling of the face, lips, tongue or throat, difficulty swallowing or breathing			√

If you have a troublesome symptom or side effect that is not listed here or becomes bad enough to interfere with your daily activities, talk to your healthcare professional.

Reporting Side Effects

You can help improve the safe use of health products for Canadians by reporting serious and unexpected side effects to Health Canada. Your report may help to identify new side effects and change the product safety information.

3 ways to report:

- Online at [MedEffect](#);
- By calling 1-866-234-2345 (toll-free);
- By completing a Consumer Side Effect Reporting Form and sending it by:
 - Fax to 1-866-678-6789 (toll-free), or
 - Mail to: Canada Vigilance Program
Health Canada, Postal Locator 0701E
Ottawa, ON
K1A 0K9

Postage paid labels and the Consumer Side Effect Reporting Form are available at [MedEffect](#).

NOTE: Contact your health professional if you need information about how to manage your side effects. The Canada Vigilance Program does not provide medical advice.

Storage:

Store RAVICTI between 15-30°C.

Keep in original packaging to protect from light.

Use the contents of the bottle within 90 days after opening.

Keep out of reach and sight of children.

If you want more information about RAVICTI:

- Talk to your healthcare professional

- Find the full product monograph that is prepared for healthcare professionals and includes this Patient Medication Information by visiting the [Health Canada website \(http://hc-sc.gc.ca/index-eng.php\)](http://hc-sc.gc.ca/index-eng.php); the manufacturer's website <http://www.RAVICTI.CA>, or by calling 1-855-823-7878.

Talk to your doctor about participating in a UCD registry. The purpose of this registry is to collect information about people with UCD to improve care.

This leaflet was prepared by Horizon Pharma Ireland Ltd.

Last Revised: MARCH-16-2016

HIGHLIGHTS OF PRESCRIBING INFORMATION

These highlights do not include all the information needed to use RAVICTI safely and effectively. See full prescribing information for RAVICTI.

RAVICTI® (glycerol phenylbutyrate) oral liquid

Initial U.S. Approval: 1996

RECENT MAJOR CHANGES

Indications and Usage (1)	12/2018
Dosage and Administration (2.4)	12/2018
Contraindications (removed) (4)	12/2018
Warnings and Precautions (5.1)	12/2018

INDICATIONS AND USAGE

RAVICTI is a nitrogen-binding agent indicated for chronic management of patients with urea cycle disorders (UCDs) who cannot be managed by dietary protein restriction and/or amino acid supplementation alone. RAVICTI must be used with dietary protein restriction and, in some cases, dietary supplements. (1)

Limitations of Use:

- RAVICTI is not indicated for treatment of acute hyperammonemia in patients with UCDs. (1)
- Safety and efficacy for treatment of N-acetylglutamate synthase (NAGS) deficiency has not been established. (1)

DOSAGE AND ADMINISTRATION

- RAVICTI should be prescribed by a physician experienced in management of UCDs. For administration and preparation, see full prescribing information. (2.1, 2.6)

Switching From Sodium Phenylbutyrate Tablets or Powder to RAVICTI:

- Patients should receive the dosage of RAVICTI that contains the same amount of phenylbutyric acid, see full prescribing information for conversion. (2.2)

Initial Dosage in Phenylbutyrate-Naïve Patients (2.3):

- Recommended dosage range is 4.5 to 11.2 mL/m²/day (5 to 12.4 g/m²/day).
- For patients with some residual enzyme activity not adequately controlled with dietary restriction, the recommended starting dose is 4.5 mL/m²/day.
- Take into account patient's estimated urea synthetic capacity, dietary protein intake, and diet adherence.

Dosage Adjustment and Monitoring:

- Follow plasma ammonia levels to determine the need for dosage titration. (2.4)

Dosage Modifications in Patients with Hepatic Impairment:

- Start dosage at lower end of range. (2.5, 8.7)

DOSAGE FORMS AND STRENGTHS

Oral liquid: 1.1 g/mL. (3)

CONTRAINDICATIONS

Known hypersensitivity to phenylbutyrate. (4)

WARNINGS AND PRECAUTIONS

- Neurotoxicity:** Phenylacetate (PAA), the active moiety of RAVICTI, may be toxic; reduce dosage for symptoms of neurotoxicity. (5.1)
- Pancreatic Insufficiency or Intestinal Malabsorption:** Monitor ammonia levels closely. (5.2)

ADVERSE REACTIONS

Most common adverse reactions (≥10%) in adults are: diarrhea, flatulence, and headache. (6.1)

To report SUSPECTED ADVERSE REACTIONS, contact Horizon Therapeutics at 1-855-823-7878 or FDA at 1-800-FDA-1088 or www.fda.gov/medwatch.

DRUG INTERACTIONS

- Corticosteroids, valproic acid, or haloperidol:** May increase plasma ammonia level; monitor ammonia levels closely. (7.1)
- Probenecid:** May affect renal excretion of metabolites of RAVICTI, including phenylacetylglutamine (PAGN) and PAA. (7.2)
- CYP3A4 Substrates with narrow therapeutic index (e.g., alfentanil, quinidine, cyclosporine):** RAVICTI may decrease exposure; monitor for decreased efficacy of the narrow therapeutic index drug. (7.3)
- Midazolam:** Decreased exposure; monitor for suboptimal effect of midazolam. (7.3)

USE IN SPECIFIC POPULATIONS

Lactation: Breastfeeding is not recommended. (8.2)

See 17 for PATIENT COUNSELING INFORMATION and Medication Guide.

Revised: 10/2019

FULL PRESCRIBING INFORMATION: CONTENTS*

1	INDICATIONS AND USAGE	8.2	Lactation
2	DOSAGE AND ADMINISTRATION	8.4	Pediatric Use
2.1	Important Administration Instructions	8.5	Geriatric Use
2.2	Switching From Sodium Phenylbutyrate to RAVICTI	8.6	Renal Impairment
2.3	Initial Dosage in Phenylbutyrate-Naïve Patients	8.7	Hepatic Impairment
2.4	Dosage Adjustment and Monitoring	10	OVERDOSAGE
2.5	Dosage Modifications in Patients with Hepatic Impairment	11	DESCRIPTION
2.6	Preparation for Nasogastric Tube or Gastrostomy Tube Administration	12	CLINICAL PHARMACOLOGY
3	DOSAGE FORMS AND STRENGTHS	12.1	Mechanism of Action
4	CONTRAINDICATIONS	12.2	Pharmacodynamics
5	WARNINGS AND PRECAUTIONS	12.3	Pharmacokinetics
5.1	Neurotoxicity	13	NONCLINICAL TOXICOLOGY
5.2	Pancreatic Insufficiency or Intestinal Malabsorption	13.1	Carcinogenesis, Mutagenesis, Impairment of Fertility
6	ADVERSE REACTIONS	14	CLINICAL STUDIES
6.1	Clinical Trials Experience	14.1	Clinical Studies in Adult Patients with UCDs
6.2	Postmarketing Experience	14.2	Clinical Studies in Pediatric Patients 2 Years to 17 Years of Age with UCDs
7	DRUG INTERACTIONS	14.3	Clinical Studies in Pediatric Patients Less Than 2 Years of Age with UCDs
7.1	Potential for Other Drugs to Affect Ammonia	16	HOW SUPPLIED/STORAGE AND HANDLING
7.2	Potential for Other Drugs to Affect RAVICTI	17	PATIENT COUNSELING INFORMATION
7.3	Potential for RAVICTI to Affect Other Drugs		
8	USE IN SPECIFIC POPULATIONS		
8.1	Pregnancy		

*Sections or subsections omitted from the full prescribing information are not listed.

FULL PRESCRIBING INFORMATION

1 INDICATIONS AND USAGE

RAVICTI is indicated for use as a nitrogen-binding agent for chronic management of patients with urea cycle disorders (UCDs) who cannot be managed by dietary protein restriction and/or amino acid supplementation alone. RAVICTI must be used with dietary protein restriction and, in some cases, dietary supplements (e.g., essential amino acids, arginine, citrulline, protein-free calorie supplements).

Limitations of Use:

- RAVICTI is not indicated for the treatment of acute hyperammonemia in patients with UCDs because more rapidly acting interventions are essential to reduce plasma ammonia levels.
- The safety and efficacy of RAVICTI for the treatment of *N*-acetylglutamate synthase (NAGS) deficiency has not been established.

2 DOSAGE AND ADMINISTRATION

2.1 Important Administration Instructions

RAVICTI should be prescribed by a physician experienced in the management of UCDs.

- Instruct patients to take RAVICTI with food or formula and to administer directly into the mouth via oral syringe or dosing cup.
- Instruct that RAVICTI should be administered just prior to breastfeeding in infants who are breastfeeding.
- For patients who cannot swallow, see the instructions on administration of RAVICTI by nasogastric tube or gastrostomy tube [*see Dosage and Administration (2.6)*].
- For patients who require a volume of less than 1 mL per dose via nasogastric or gastrostomy tube, the delivered dose may be less than anticipated. Closely monitor these patients using ammonia levels [*see Dosage and Administration (2.6)*].
- The recommended dosages for patients switching from sodium phenylbutyrate to RAVICTI and patients naïve to phenylbutyric acid are different [*see Dosage and Administration (2.2, 2.3)*]. For both subpopulations:
 - Patients 2 years of age and older: Give RAVICTI in 3 equally divided dosages, each rounded up to the nearest 0.5 mL
 - Patients less than 2 years: Give RAVICTI in 3 or more equally divided dosages, each rounded up to the nearest 0.1 mL.
 - The maximum total daily dosage is 17.5 mL (19 g).

- RAVICTI must be used with dietary protein restriction and, in some cases, dietary supplements (e.g., essential amino acids, arginine, citrulline, protein-free calorie supplements).

2.2 Switching From Sodium Phenylbutyrate to RAVICTI

Patients switching from sodium phenylbutyrate to RAVICTI should receive the dosage of RAVICTI that contains the same amount of phenylbutyric acid. The conversion is as follows:

Total daily dosage of RAVICTI (mL) = total daily dosage of sodium phenylbutyrate tablets (g) x 0.86

Total daily dosage of RAVICTI (mL) = total daily dosage of sodium phenylbutyrate powder (g) x 0.81

2.3 Initial Dosage in Phenylbutyrate-Naïve Patients

The recommended dosage range, based upon body surface area, in patients naïve to phenylbutyrate (PBA) is 4.5 to 11.2 mL/m²/day (5 to 12.4 g/m²/day). For patients with some residual enzyme activity who are not adequately controlled with protein restriction, the recommended starting dosage is 4.5 mL/m²/day.

In determining the starting dosage of RAVICTI in treatment-naïve patients, consider the patient's residual urea synthetic capacity, dietary protein requirements, and diet adherence. Dietary protein is approximately 16% nitrogen by weight. Given that approximately 47% of dietary nitrogen is excreted as waste and approximately 70% of an administered PBA dose will be converted to urinary phenylacetylglutamine (U-PAGN), an initial estimated RAVICTI dose for a 24-hour period is 0.6 mL RAVICTI per gram of dietary protein ingested per 24-hour period. The total daily dosage should not exceed 17.5 mL.

2.4 Dosage Adjustment and Monitoring

During treatment with RAVICTI, patients should be followed clinically and with plasma ammonia levels to determine the need for dosage titration. Closely monitor plasma ammonia levels during treatment with RAVICTI and when changing the dosage of RAVICTI.

The methods used for measuring plasma ammonia levels vary among individual laboratories and values obtained using different assay methods may not be interchangeable. Normal ranges and therapeutic target levels for plasma ammonia depend upon the assay method used by the individual laboratory. During treatment with RAVICTI, refer to the assay-specific normal ranges and to the therapeutic target ranges for plasma ammonia.

Normal Plasma Ammonia

In patients treated with RAVICTI who experience neurologic symptoms (e.g. nausea, vomiting, headache, somnolence or confusion) in the absence of high plasma ammonia or other intercurrent illness to explain these symptoms, consider reducing the RAVICTI dosage and clinically monitor patients for potential neurotoxicity from high phenylacetate (PAA) concentrations. If available, obtain measurements of plasma PAA concentrations and plasma phenylacetylglutamine (PAGN) to calculate the ratio of plasma PAA to PAGN which may help to guide RAVICTI dosing. The PAA to PAGN ratio has generally been less than 1 in patients with UCDs who did not have significant plasma PAA accumulation. In general, a high PAA to PAGN ratio may indicate a slower or less efficient conjugation reaction to form

PAGN, which may lead to increases in PAA without further conversion to PAGN [see *Warnings and Precautions (5.1), Clinical Pharmacology (12.3)*].

Elevated Plasma Ammonia

In patients 6 years and older, when plasma ammonia is elevated, increase the RAVICTI dosage to maintain fasting plasma ammonia to less than half the upper limit of normal (ULN). In infants and pediatric patients below 6 years of age, if obtaining fasting ammonia is problematic due to frequent feedings, adjust the RAVICTI dosage to keep the first ammonia of the morning below the ULN for age. If available, the ratio of PAA to PAGN in the same plasma sample may provide additional information to assist in dosage adjustment decisions [see *Use in Specific Populations (8.7), Clinical Pharmacology (12.3)*].

Dietary Protein Intake

If available, urinary phenylacetylglutamine (U-PAGN) measurements may be used to help guide RAVICTI dosage adjustment. Each gram of U-PAGN excreted over 24 hours covers waste nitrogen generated from 1.4 grams of dietary protein. If U-PAGN excretion is insufficient to cover daily dietary protein intake and the fasting ammonia is greater than half the ULN, the RAVICTI dosage should be increased. The amount of dosage adjustment should factor in the amount of dietary protein that has not been covered, as indicated by the 24-hour U-PAGN output, and the estimated RAVICTI dose needed per gram of dietary protein ingested and the maximum total daily dosage (i.e., 17.5 mL).

Consider a patient's use of concomitant medications, such as probenecid, when making dosage adjustment decisions based on U-PAGN. Probenecid may result in a decrease of the urinary excretion of PAGN [see *Drug Interactions (7.2)*].

2.5 Dosage Modifications in Patients with Hepatic Impairment

For patients with moderate to severe hepatic impairment, the recommended starting dosage is at the lower end of the recommended dosing range (4.5 mL/m²/day) and the dosage should be kept at the lowest necessary to control the patient's plasma ammonia [see *Use in Specific Populations (8.7)*].

2.6 Preparation for Nasogastric Tube or Gastrostomy Tube Administration

It is recommended that all patients who can swallow take RAVICTI orally, even those with nasogastric and/or gastrostomy tubes. However, for patients who cannot swallow, a nasogastric tube or gastrostomy tube may be used to administer RAVICTI as follows:

- Utilize an oral syringe to withdraw the prescribed dosage of RAVICTI from the bottle.
- Place the tip of the syringe into the nasogastric/gastrostomy tube.
- Utilizing the plunger of the syringe, administer RAVICTI into the tube.
- Flush once with 10 mL of water or formula and allow the flush to drain.

- If needed, flush a second time with an additional 10 mL of water or formula to clear the tube.

For patients who require a volume of less than 1 mL per dose via nasogastric or gastrostomy tube, the delivered dosage may be less than anticipated due to adherence of RAVICTI to the plastic tubing. Therefore, these patients should be closely monitored using ammonia levels following initiation of RAVICTI dosing or dosage adjustments.

3 DOSAGE FORMS AND STRENGTHS

Oral liquid: colorless to pale yellow, 1.1 g/mL of glycerol phenylbutyrate (delivers 1.02 g/mL of phenylbutyrate).

4 CONTRAINDICATIONS

RAVICTI is contraindicated in patients with known hypersensitivity to phenylbutyrate. Signs of hypersensitivity include wheezing, dyspnea, coughing, hypotension, flushing, nausea, and rash.

5 WARNINGS AND PRECAUTIONS

5.1 Neurotoxicity

Increased exposure to PAA, the major metabolite of RAVICTI, may be associated with neurotoxicity in patients with UCDs. In a study of adult cancer patients, subjects received sodium phenylacetate administered as a 1-hour infusion twice daily at two dose levels of 125 and 150 mg/kg for a 2-week period. Of 18 subjects enrolled, 7 had a history of primary central nervous system tumor. Signs and symptoms of potential PAA neurotoxicity, which were reversible, were reported at plasma PAA concentrations above 500 micrograms/mL and included somnolence, fatigue, lightheadedness, headache, dysgeusia, hypoacusis, disorientation, impaired memory, and exacerbation of preexisting neuropathy. PAA concentrations were not measured when symptoms resolved.

In healthy subjects, after administration of 4 mL and 6 mL RAVICTI 3 times daily (13.2 g/day and 19.8 g/day, respectively) for 3 days, a dose-dependent increase in non-serious nervous system adverse reactions were observed. In subjects who had nervous system adverse reactions, plasma PAA concentrations, which were measured on Day 3 per protocol and not always at onset of symptoms, ranged from 8 to 56 micrograms/mL with 4 mL RAVICTI 3 times daily and from 31 to 242 micrograms/mL with 6 mL RAVICTI 3 times daily.

In clinical trials in patients with UCDs who had been on sodium phenylbutyrate prior to administration of RAVICTI, adverse reactions of headache, fatigue, symptoms of peripheral neuropathy, seizures, tremor and/or dizziness were reported. No correlation between plasma PAA concentration and neurologic symptoms was identified but plasma PAA concentrations were generally not consistently measured at the time of neurologic symptom occurrence [*see Clinical Pharmacology (12.3)*].

If symptoms of vomiting, nausea, headache, somnolence or confusion are present in the absence of high ammonia or other intercurrent illness which explains these symptoms, consider the potential for PAA neurotoxicity which may need reduction in the RAVICTI dosage [see *Dosage and Administration (2.4)*].

5.2 Pancreatic Insufficiency or Intestinal Malabsorption

Exocrine pancreatic enzymes hydrolyze RAVICTI in the small intestine, separating the active moiety, phenylbutyrate, from glycerol. This process allows phenylbutyrate to be absorbed into the circulation. Low or absent pancreatic enzymes or intestinal disease resulting in fat malabsorption may result in reduced or absent digestion of RAVICTI and/or absorption of phenylbutyrate and reduced control of plasma ammonia. Monitor ammonia levels closely in patients with pancreatic insufficiency or intestinal malabsorption.

6 ADVERSE REACTIONS

6.1 Clinical Trials Experience

Because clinical trials are conducted under widely varying conditions, adverse reaction rates observed in the clinical trials of a drug cannot be directly compared to rates in the clinical trials of another drug and may not reflect the rates observed in clinical practice.

Assessment of adverse reactions was based on exposure of 45 adult patients (31 female and 14 male) with UCD subtype deficiencies of ornithine transcarbamylase (OTC, n=40), carbamoyl phosphate synthetase (CPS, n=2), and argininosuccinate synthetase (ASS, n=1) in a randomized, double-blind, active-controlled (RAVICTI vs sodium phenylbutyrate), crossover, 4-week study (Study 1) that enrolled patients 18 years of age and older [see *Clinical Studies (14.1)*]. One of the 45 patients received only sodium phenylbutyrate prior to withdrawing on day 1 of the study due to an adverse reaction.

The most common adverse reactions (occurring in at least 10% of patients) reported during short-term treatment with RAVICTI were diarrhea, flatulence, and headache. Table 1 summarizes adverse reactions occurring in 2 or more patients treated with RAVICTI or sodium phenylbutyrate (incidence of at least 4% in either treatment arm).

Table 1: Adverse Reactions Reported in 2 or More Adult Patients with UCDs (at least 4% in Either Treatment Arm) in Study 1

	Number (%) of Patients in Study 1	
	Sodium Phenylbutyrate (N = 45)	RAVICTI (N = 44)
Diarrhea	3 (7)	7 (16)
Headache	4 (9)	6 (14)
Flatulence	1 (2)	6 (14)
Abdominal pain	2 (4)	3 (7)
Vomiting	2 (4)	3 (7)
Decreased appetite	2 (4)	3 (7)
Fatigue	1 (2)	3 (7)
Dyspepsia	3 (7)	2 (5)

	Number (%) of Patients in Study 1	
	Sodium Phenylbutyrate (N = 45)	RAVICTI (N = 44)
Nausea	3 (7)	1 (2)
Dizziness	4 (9)	0
Abdominal discomfort	3 (7)	0

Other Adverse Reactions

RAVICTI has been evaluated in 77 patients with UCDs (51 adult and 26 pediatric patients ages 2 years to 17 years) in 2 open-label long-term studies, in which 69 patients completed 12 months of treatment with RAVICTI (median exposure = 51 weeks). During these studies there were no deaths.

Adverse reactions reported in at least 10% of adult patients were nausea, vomiting, diarrhea, decreased appetite, dizziness, headache, and fatigue.

Adverse reactions reported in at least 10% of pediatric patients ages 2 years to 17 years were upper abdominal pain, rash, nausea, vomiting, diarrhea, decreased appetite, and headache.

RAVICTI has been evaluated in 17 patients with UCDs ages 2 months to less than 2 years in 3 open-label studies. The median exposure was 6 months (range 0.2 to 20 months).

Adverse reactions reported in at least 10% of pediatric patients aged 2 months to less than 2 years were neutropenia, vomiting, constipation, diarrhea, pyrexia, hypophagia, cough, nasal congestion, rhinorrhea, rash, and papule.

RAVICTI has been evaluated in 16 patients with UCDs less than 2 months of age (age range 0.1 to 2 months, median age 0.5 months) in a single, open-label study. The median exposure was 10 months (range 2 to 20 months). Adverse reactions reported in at least 10% of pediatric patients aged less than 2 months were vomiting, rash, gastroesophageal reflux, increased hepatic enzymes, feeding disorder (decreased appetite, hypophagia), anemia, cough, dehydration, metabolic acidosis, thrombocytosis, thrombocytopenia, neutropenia, lymphocytosis, diarrhea, flatulence, constipation, pyrexia, lethargy, and irritability/agitation.

6.2 Postmarketing Experience

The following adverse reactions have been identified during post-approval use of RAVICTI. Because these reactions are reported voluntarily from a population of uncertain size, it is not always possible to reliably estimate their frequency or establish a causal relationship to drug exposure:

- Abnormal body odor, including from skin, hair and urine
- Retching and gagging
- Dysgeusia or burning sensation in mouth

7 DRUG INTERACTIONS

7.1 Potential for Other Drugs to Affect Ammonia

Corticosteroids

Use of corticosteroids may cause the breakdown of body protein and increase plasma ammonia levels. Monitor ammonia levels closely when corticosteroids and RAVICTI are used concomitantly.

Valproic Acid and Haloperidol

Hyperammonemia may be induced by haloperidol and by valproic acid. Monitor ammonia levels closely when use of valproic acid or haloperidol is necessary in patients with UCDs.

7.2 Potential for Other Drugs to Affect RAVICTI

Probenecid

Probenecid may inhibit the renal excretion of metabolites of RAVICTI including PAGN and PAA.

7.3 Potential for RAVICTI to Affect Other Drugs

Drugs with narrow therapeutic index that are substrates of CYP3A4

RAVICTI is a weak inducer of CYP3A4 in humans. Concomitant use of RAVICTI may decrease the systemic exposure to drugs that are substrates of CYP3A4. Monitor for decreased efficacy of drugs with narrow therapeutic index (e.g., alfentanil, quinidine, cyclosporine) [see *Clinical Pharmacology* (12.3)].

Midazolam

Concomitant use of RAVICTI decreased the systemic exposure of midazolam. Monitor for suboptimal effect of midazolam in patients who are being treated with RAVICTI.

8 USE IN SPECIFIC POPULATIONS

8.1 Pregnancy

Pregnancy Exposure Registry

There is a pregnancy exposure registry that monitors pregnancy outcomes in women exposed to RAVICTI during pregnancy. Healthcare providers are encouraged to report any prenatal exposure to RAVICTI by calling the Pregnancy Registry at 1-855-823-2595 or visiting www.ucdregistry.com.

Risk Summary

Limited available data with RAVICTI use in pregnant women are insufficient to inform a drug-associated risk of major birth defects and miscarriage. In an animal reproduction study, administration of oral glycerol phenylbutyrate to pregnant rabbits during organogenesis at doses up to 2.7–times the dose of 6.87 mL/m²/day in adult patients resulted in maternal

toxicity, but had no effects on embryo-fetal development. In addition, there were no adverse developmental effects with administration of oral glycerol phenylbutyrate to pregnant rats during organogenesis at 1.9 times the dose of 6.87 mL/m²/day in adult patients; however, maternal toxicity, reduced fetal weights, and variations in skeletal development were observed in pregnant rats administered oral glycerol phenylbutyrate during organogenesis at doses greater than or equal to 5.7 times the dose of 6.87 mL/m²/day in adult patients [see *Data*].

The estimated background risk of major birth defects and miscarriage for the indicated population is unknown. All pregnancies have a background risk of birth defect, loss or other adverse outcomes. In the U.S. general population, the estimated background risk of major birth defects and miscarriage in clinically recognized pregnancies is 2 to 4% and 15 to 20%, respectively.

Data

Animal Data

Oral administration of glycerol phenylbutyrate during the period of organogenesis up to 350 mg/kg/day in rabbits produced maternal toxicity, but no effects on embryo-fetal development. The dose of 350 mg/kg/day in rabbits is approximately 2.7 times the dose of 6.87 mL/m²/day in adult patients, based on combined area under the plasma concentration-time curve [AUCs] for PBA and PAA. In rats, at an oral dose of 300 mg/kg/day of glycerol phenylbutyrate (1.9 times the dose of 6.87 mL/m²/day in adult patients, based on combined AUCs for PBA and PAA) during the period of organogenesis, no effects on embryo-fetal development were observed. Doses of 650 mg/kg/day or greater produced maternal toxicity and adverse effects on embryo-fetal development including reduced fetal weights and cervical ribs at the 7th cervical vertebra. The dose of 650 mg/kg/day in rats is approximately 5.7 times the dose of 6.87 mL/m²/day in adult patients, based on combined AUCs for PBA and PAA. No developmental abnormalities, effects on growth, or effects on learning and memory were observed through maturation of offspring following oral administration in pregnant rats with up to 900 mg/kg/day of glycerol phenylbutyrate (8.5 times the dose of 6.87 mL/m²/day in adult patients, based on combined AUCs for PBA and PAA) during organogenesis and lactation.

8.2 Lactation

Risk Summary

There are no data on the presence of RAVICTI in human milk, the effects on the breastfed infant, or the effects on milk production. Because of the potential for serious adverse reactions, including neurotoxicity and tumorigenicity in a breastfed infant, advise patients that breastfeeding is not recommended during treatment with RAVICTI.

8.4 Pediatric Use

Patients 2 Years to 17 Years of Age

The safety and effectiveness of RAVICTI in patients 2 years to less than 18 years of age have been established in 3 clinical studies: 2 open-label, fixed-sequence, switchover clinical

studies from sodium phenylbutyrate to RAVICTI, and 1 long-term, open label safety study [see *Adverse Reactions (6.1), Clinical Studies (14.2)*].

Patients Less Than 2 Years of Age

The safety and effectiveness of RAVICTI in patients with UCIDs less than 2 years of age have been established in 3 open-label studies. Pharmacokinetics and pharmacodynamics (plasma ammonia), and safety were studied in 17 patients aged 2 months to less than 2 years of age and in 16 patients less than 2 months of age [see *Adverse Reactions (6.1), Clinical Studies (14.3)*].

Juvenile Animal Toxicity Data

In a juvenile rat study with daily oral dosing performed on postpartum day 2 through mating and pregnancy after maturation, terminal body weight was dose-dependently reduced by up to 16% in males and 12% in females at 900 mg/kg/day or higher (3 times the dose of 6.87 mL/m²/day in adult patients, based on combined AUCs for PBA and PAA). Learning, memory, and motor activity endpoints were not affected. However, fertility (number of pregnant rats) was decreased by up to 25% at 650 mg/kg/day or higher (2.6 times the dose of 6.87 mL/m²/day in adult patients, based on combined AUCs for PBA and PAA).

8.5 Geriatric Use

Clinical studies of RAVICTI did not include sufficient numbers of subjects 65 years of age and older to determine whether they respond differently than younger subjects. Other reported clinical experience has not identified differences in responses between the elderly and younger patients. In general, dose selection for an elderly patient should be cautious, usually starting at the low end of the dosing range, reflecting the greater frequency of decreased hepatic, renal, or cardiac function, and of concomitant disease or other drug therapy.

8.6 Renal Impairment

The efficacy and safety of RAVICTI in patients with renal impairment are unknown. Monitor ammonia levels closely when starting patients with impaired renal function on RAVICTI.

8.7 Hepatic Impairment

No studies were conducted in patients with UCIDs and hepatic impairment. Because conversion of PAA to PAGN occurs in the liver, patients with hepatic impairment may have reduced conversion capability and higher plasma PAA and PAA to PAGN ratio [see *Clinical Pharmacology (12.3)*]. Therefore, dosage for patients with moderate to severe hepatic impairment should be started at the lower end of the recommended dosing range and should be kept on the lowest dose necessary to control their ammonia levels [see *Dosage and Administration (2.5)*].

10 OVERDOSAGE

While there is no experience with overdosage in human clinical trials, PAA, a toxic metabolite of RAVICTI, can accumulate in patients who receive an overdose [see *Warnings and Precautions (5.1)*].

If over-exposure occurs, call your Poison Control Center at 1-800-222-1222 for current information on the management of poisoning or overdosage.

11 DESCRIPTION

RAVICTI (glycerol phenylbutyrate) is a clear, colorless to pale yellow oral liquid. It is insoluble in water and most organic solvents, and it is soluble in dimethylsulfoxide (DMSO) and greater than 65% acetonitrile.

Glycerol phenylbutyrate is a nitrogen-binding agent. It is a triglyceride containing 3 molecules of PBA linked to a glycerol backbone, the chemical name of which is benzenebutanoic acid, 1', 1''-(1,2,3-propanetriyl) ester with a molecular weight of 530.67. It has a molecular formula of $C_{33}H_{38}O_6$. The structural formula is:

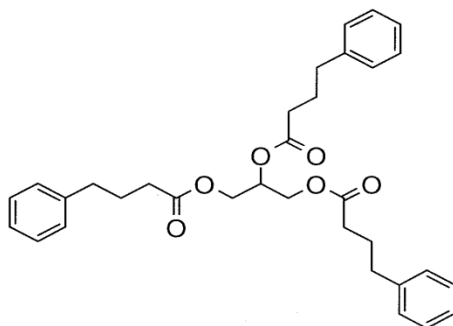

12 CLINICAL PHARMACOLOGY

12.1 Mechanism of Action

UCDs are inherited deficiencies of enzymes or transporters necessary for the synthesis of urea from ammonia (NH_3 , NH_4^+). Absence of these enzymes or transporters results in the accumulation of toxic levels of ammonia in the blood and brain of affected patients.

RAVICTI is a triglyceride containing 3 molecules of PBA. PAA, the major metabolite of PBA, is the active moiety of RAVICTI. PAA conjugates with glutamine (which contains 2 molecules of nitrogen) via acetylation in the liver and kidneys to form PAGN, which is excreted by the kidneys (Figure 1). On a molar basis, PAGN, like urea, contains 2 moles of nitrogen and provides an alternate vehicle for waste nitrogen excretion.

Figure 1: RAVICTI Mechanism of Action

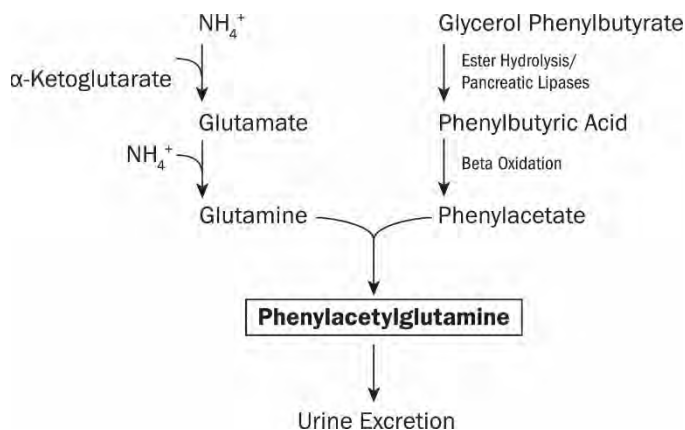

12.2 Pharmacodynamics

Pharmacological Effects

In clinical studies, total 24-hour area under the plasma concentration-time curve (AUC) of ammonia levels was comparable at steady state during the switchover period between RAVICTI and sodium phenylbutyrate [see *Clinical Studies (14)*].

Cardiac Electrophysiology

The effect of multiple doses of RAVICTI 13.2 g/day and 19.8 g/day (approximately 69% and 104% of the maximum recommended daily dosage) on QTc interval was evaluated in a randomized, placebo- and active-controlled (moxifloxacin 400 mg), four-treatment-arm, crossover study in 57 healthy subjects. The upper bound of the one-sided 95% CI for the largest placebo-adjusted, baseline-corrected QTc, based on individual correction method (QTcI) for RAVICTI, was below 10 ms.

12.3 Pharmacokinetics

Absorption

RAVICTI is a pro-drug of PBA. Upon oral ingestion, PBA is released from the glycerol backbone in the gastrointestinal tract by lipases. PBA derived from RAVICTI is further converted by β -oxidation to PAA.

In healthy, fasting adult subjects receiving a single oral dose of 2.9 mL/m² of RAVICTI, peak plasma levels of PBA, PAA, and PAGN occurred at 2 hours, 4 hours, and 4 hours, respectively. Upon single-dose administration of RAVICTI, plasma concentrations of PBA were quantifiable in 15 of 22 participants at the first sample time postdose (0.25 hours). Mean maximum concentration (C_{\max}) for PBA, PAA, and PAGN was 37.0 micrograms/mL, 14.9 micrograms/mL, and 30.2 micrograms/mL, respectively. In healthy subjects, intact

glycerol phenylbutyrate was detected in plasma. While the study was inconclusive, the incomplete hydrolysis of glycerol phenylbutyrate cannot be ruled out.

In healthy subjects, the systemic exposure to PAA, PBA, and PAGN increased in a dose-dependent manner. Following 4 mL of RAVICTI 3 times a day for 3 days, the mean C_{max} and AUC were 66 micrograms/mL and 930 micrograms•h/mL for PBA and 28 micrograms/mL and 942 micrograms•h/mL for PAA, respectively. In the same study, following 6 mL of RAVICTI three times a day for 3 days, mean C_{max} and AUC were 100 micrograms/mL and 1400 micrograms•h/mL for PBA and 65 µg/mL and 2064 micrograms•h/mL for PAA, respectively.

In adult patients with UCDs receiving multiple doses of RAVICTI, maximum plasma concentrations at steady state ($C_{max,ss}$) of PBA, PAA, and PAGN occurred at 8 hours, 12 hours, and 10 hours, respectively, after the first dose in the day. Intact glycerol phenylbutyrate was not detectable in plasma in patients with UCDs.

In clinical studies of RAVICTI in patients with UCDs, the peak observed PAA concentrations by age group are shown in Table 2.

Table 2: Peak PAA Concentrations in Patients with UCDs Treated with RAVICTI in Clinical Trials

Age Range	RAVICTI Dose	Mean Peak PAA Concentration* (SD)	Median Peak PAA Concentration * (Range)
Less than 2 months (n=16)	3.1 to 12.7 mL/m ² /day (3.4 to 14 g/m ² /day)	257 (162)	205 (96 to 707)
2 months to less than 2 years (n=17)	3.3 to 12.3 mL/m ² /day (3.7 to 13.5 g/m ² /day)	142 (299)	35 (1 to 1215)
2 years to 17 years (n=53)	1.4 to 13.7 mL/m ² /day (1.5 to 15.1 g/m ² /day)	70 (79)	50 (1 to 410)
Adults (n=43)	0.6 to 14 mL/m ² /day (0.7 to 15.4 g/m ² /day)	39 (40)	25 (1.6 to 178)

*micrograms/mL

Distribution

In vitro, the extent of plasma protein binding for ¹⁴C-labeled metabolites was 81% to 98% for PBA (over 1 to 250 micrograms/mL), and 37% to 66% for PAA (over 5 to 500 micrograms/mL). The protein binding for PAGN was 7% to 12% and no concentration effects were noted.

Elimination

Metabolism

Upon oral administration, pancreatic lipases hydrolyze RAVICTI (i.e., glycerol phenylbutyrate), and release PBA. PBA undergoes β-oxidation to PAA, which is conjugated with glutamine in the liver and in the kidney through the enzyme phenylacetyl-CoA: L-glutamine-N-acetyltransferase to form PAGN. PAGN is subsequently eliminated in the urine.

Saturation of conjugation of PAA and glutamine to form PAGN was suggested by increases in the ratio of plasma PAA to PAGN with increasing dose and with increasing severity of hepatic impairment.

In healthy subjects, after administration of 4 mL, 6 mL, and 9 mL 3 times daily for 3 days, the ratio of mean AUC_{0-23h} of PAA to PAGN was 1, 1.25, and 1.6, respectively. In a separate study, in patients with hepatic impairment (Child-Pugh B and C), the ratios of mean C_{max} values for PAA to PAGN among all patients dosed with 6 mL and 9 mL twice daily were 3 and 3.7.

In *in vitro* studies, the specific activity of lipases for glycerol phenylbutyrate was in the following decreasing order: pancreatic triglyceride lipase, carboxyl ester lipase, and pancreatic lipase-related protein 2. Further, glycerol phenylbutyrate was hydrolyzed *in vitro* by esterases in human plasma. In these *in vitro* studies, a complete disappearance of glycerol phenylbutyrate did not produce molar equivalent PBA, suggesting the formation of mono- or bis-ester metabolites. However, the formation of mono- or bis-esters was not studied in humans.

Excretion

The mean (SD) percentage of administered PBA excreted as PAGN was approximately 69% (17) in adults and 66% (24) in pediatric patients with UCDs at steady state. PAA and PBA represented minor urinary metabolites, each accounting for less than 1% of the administered dose of PBA.

Specific Populations

Age: Pediatric Population

Population pharmacokinetic modeling and dosing simulations suggest body surface area to be the most significant covariate explaining the variability of PAA clearance. PAA clearance was 10.9 L/h, 16.4 L/h, and 24.4 L/h, respectively, for patients ages 3 to 5, 6 to 11, and 12 to 17 years with UCDs.

In pediatric patients with UCDs (n = 14) ages 2 months to less than 2 years, PAA clearance was 6.8 L/h.

In pediatric patients with UCDs (n = 16) ages less than 2 months, PAA clearance was 3.8 L/h. The mean peak ratio of PAA to PAGN in UCD patients aged birth to less than 2 months was higher (mean: 1.6; range 0.1 to 7.1) than that of UCD patients aged 2 months to less than 2 years (mean 0.5; range 0.1 to 1.2).

Sex

In healthy adult subjects, a gender effect was found for all metabolites, with women generally having higher plasma concentrations of all metabolites than men at a given dose level. In healthy female subjects, mean C_{max} for PAA was 51 and 120% higher than in male volunteers after administration of 4 mL and 6 mL 3 times daily for 3 days, respectively. The dose normalized mean AUC_{0-23h} for PAA was 108% higher in females than in males.

Renal Impairment

The pharmacokinetics of RAVICTI in patients with impaired renal function, including those with end-stage renal disease (ESRD) or those on hemodialysis, have not been studied [*see Use in Specific Populations (8.6)*].

Hepatic Impairment

The effects of hepatic impairment on the pharmacokinetics of RAVICTI were studied in patients with mild, moderate and severe hepatic impairment of (Child-Pugh class A, B, and C, respectively) receiving 100 mg/kg of RAVICTI twice daily for 7 days.

Plasma glycerol phenylbutyrate was not measured in patients with hepatic impairment.

After multiple doses of RAVICTI in patients with hepatic impairment of Child-Pugh A, B, and C, geometric mean AUC_t of PBA was 42%, 84%, and 50% higher, respectively, while geometric mean AUC_t of PAA was 22%, 53%, and 94% higher, respectively, than in healthy subjects.

In patients with hepatic impairment of Child-Pugh A, B, and C, geometric mean AUC_t of PAGN was 42%, 27%, and 22% lower, respectively, than that in healthy subjects.

The proportion of PBA excreted as PAGN in the urine in Child-Pugh A, B, and C was 80%, 58%, and 85%, respectively, and, in healthy volunteers, was 67%.

In another study in patients with moderate and severe hepatic impairment (Child-Pugh B and C), mean C_{max} of PAA was 144 micrograms/mL (range: 14 to 358 micrograms/mL) after daily dosing of 6 mL of RAVICTI twice daily, while mean C_{max} of PAA was 292 micrograms/mL (range: 57 to 655 micrograms/mL) after daily dosing of 9 mL of RAVICTI twice daily. The ratio of mean C_{max} values for PAA to PAGN among all patients dosed with 6 mL and 9 mL twice daily were 3 and 3.7, respectively.

After multiple doses, a PAA concentration greater than 200 micrograms/mL was associated with a ratio of plasma PAA to PAGN concentrations higher than 2.5 [*see Dosage and Administration (2.5)*].

Drug Interaction Studies

In vitro PBA or PAA did not induce CYP1A2, suggesting that *in vivo* drug interactions via induction of CYP1A2 is unlikely.

In *in vitro* studies, PBA at a concentration of 800 micrograms/mL caused greater than 60% reversible inhibition of cytochrome P450 isoenzymes CYP2C9, CYP2D6, and CYP3A4/5 (testosterone 6β-hydroxylase activity). The *in vitro* study suggested that *in vivo* drug interactions with substrates of CYP2D6 cannot be ruled out. The inhibition of CYP isoenzymes 1A2, 2C8, 2C19, and 2D6 by PAA at the concentration of 2.8 mg/mL was observed *in vitro*. Clinical implication of these results is unknown.

Effects of RAVICTI on other drugs

Midazolam

In healthy subjects, when oral midazolam was administered after multiple doses of RAVICTI (4 mL three times a day for 3 days) under fed conditions, the mean C_{max} and AUC for

midazolam were 25% and 32% lower, respectively, compared to administration of midazolam alone. In addition, the mean C_{\max} and AUC for 1-hydroxy midazolam were 28% and 58% higher, respectively, compared to administration of midazolam alone [see *Drug Interactions* (7.3)].

Celecoxib

Concomitant administration of RAVICTI did not significantly affect the pharmacokinetics of celecoxib, a substrate of CYP2C9. When 200 mg of celecoxib was orally administered with RAVICTI after multiple doses of RAVICTI (4 mL three times a day for 6 days) under fed conditions (a standard breakfast was consumed 5 minutes after celecoxib administration), the mean C_{\max} and AUC for celecoxib were 13% and 8% lower than after administration of celecoxib alone.

13 NONCLINICAL TOXICOLOGY

13.1 Carcinogenesis, Mutagenesis, Impairment of Fertility

Carcinogenesis

In a 2-year study in Sprague-Dawley rats, glycerol phenylbutyrate caused a statistically significant increase in the incidence of pancreatic acinar cell adenoma, carcinoma, and combined adenoma or carcinoma at a dose of 650 mg/kg/day in males (4.7 times the dose of 6.9 mL/m²/day in adult patients, based on combined AUCs for PBA and PAA) and 900 mg/kg/day in females (8.4 times the dose of 6.9 mL/m²/day in adult patients, based on combined AUCs for PBA and PAA). The incidence of the following tumors was also increased in female rats at a dose of 900 mg/kg/day: thyroid follicular cell adenoma, carcinoma and combined adenoma or carcinoma, adrenal cortical combined adenoma or carcinoma, uterine endometrial stromal polyp, and combined polyp or sarcoma. The dose of 650 mg/kg/day in male rats is 3 times the dose of 7.5 mL/m²/day in pediatric patients, based on combined AUCs for PBA and PAA. The dose of 900 mg/kg/day in female rats is 5.5 times the dose of 7.5 mL/m²/day in pediatric patients, based on combined AUCs for PBA and PAA. In a 26-week study in transgenic (Tg.rasH2) mice, glycerol phenylbutyrate was not tumorigenic at doses up to 1000 mg/kg/day.

Mutagenesis

Glycerol phenylbutyrate was not genotoxic in the Ames test, the *in vitro* chromosomal aberration test in human peripheral blood lymphocytes, or the *in vivo* rat micronucleus test. The metabolites PBA, PAA, PAGN, and phenylacetyl glycine were not genotoxic in the Ames test or *in vitro* chromosome aberration test in Chinese hamster ovary cells.

Impairment of Fertility

Glycerol phenylbutyrate had no effect on fertility or reproductive function in male and female rats at oral doses up to 900 mg/kg/day. At doses of 1200 mg/kg/day (approximately 7 times the dose of 6.9 mL/m²/day in adult patients, based on combined AUCs for PBA and PAA), maternal toxicity was observed and the number of nonviable embryos was increased.

14 CLINICAL STUDIES

14.1 Clinical Studies in Adult Patients with UCDS

Active-Controlled, 4-Week, Noninferiority Study (Study 1)

A randomized, double-blind, active-controlled, crossover, noninferiority study (Study 1) compared RAVICTI to sodium phenylbutyrate by evaluating ammonia levels in patients with UCDS who had been on sodium phenylbutyrate prior to enrollment for control of their UCD. Patients were required to have a confirmed diagnosis of UCD involving deficiencies of CPS, OTC, or ASS, confirmed via enzymatic, biochemical, or genetic testing. Patients had to have no clinical evidence of hyperammonemia at enrollment and were not allowed to receive drugs known to increase ammonia levels (e.g., valproate), increase protein catabolism (e.g., corticosteroids), or significantly affect renal clearance (e.g., probenecid).

The primary endpoint was the 24-hour AUC (a measure of exposure to ammonia over 24 hours) for venous ammonia on days 14 and 28 when the drugs were expected to be at steady state. Statistical noninferiority would be established if the upper limit of the 2-sided 95% CI for the ratio of the geometric means (RAVICTI/sodium phenylbutyrate) for the endpoint was 1.25 or less.

Forty-five patients were randomized 1:1 to 1 of 2 treatment arms to receive either

- Sodium phenylbutyrate for 2 weeks → RAVICTI for 2 weeks; or
- RAVICTI for 2 weeks → sodium phenylbutyrate for 2 weeks.

Sodium phenylbutyrate or RAVICTI were administered three times daily with meals. The dose of RAVICTI was calculated to deliver the same amount of PBA as the sodium phenylbutyrate dose the patients were taking when they entered the study. Forty-four patients received at least 1 dose of RAVICTI in the study.

Patients adhered to a low-protein diet and received amino acid supplements throughout the study. After 2 weeks of dosing, by which time patients had reached steady state on each treatment, all patients had 24 hours of ammonia measurements.

Demographic characteristics of the 45 patients enrolled in Study 1 were as follows: mean age at enrollment was 33 years (range: 18 to 75 years); 69% were female; 33% had adult-onset disease; 89% had OTC deficiency; 7% had ASS deficiency; 4% had CPS deficiency.

RAVICTI was non-inferior to sodium phenylbutyrate with respect to the 24-hour AUC for ammonia. Forty-four patients were evaluated in this analysis. Mean 24-hour AUCs for ammonia during steady-state dosing were 866 micromol•h/L and 977 micromol•h/L with RAVICTI and sodium phenylbutyrate, respectively. The ratio of geometric means was 0.91 [95% CI 0.8, 1.04].

The mean ammonia levels over 24-hours after 2 weeks of dosing (on day 14 and 28) in the double-blind short-term study (Study 1) are displayed in Figure 2 below. The mean and median maximum ammonia levels (C_{max}) over 24 hours and 24-hour AUC for ammonia are summarized in Table 3. Ammonia values across different laboratories were normalized to a common normal range of 9 to 35 micromol/L using the following formula after standardization of the units to micromol/L:

Normalized ammonia (micromol/L) = ammonia readout in micromol/L x (35/ULN of a laboratory reference range specified for each assay)

Figure 2: Ammonia Levels in Adult Patients with UCDs in Short-Term Treatment Study 1

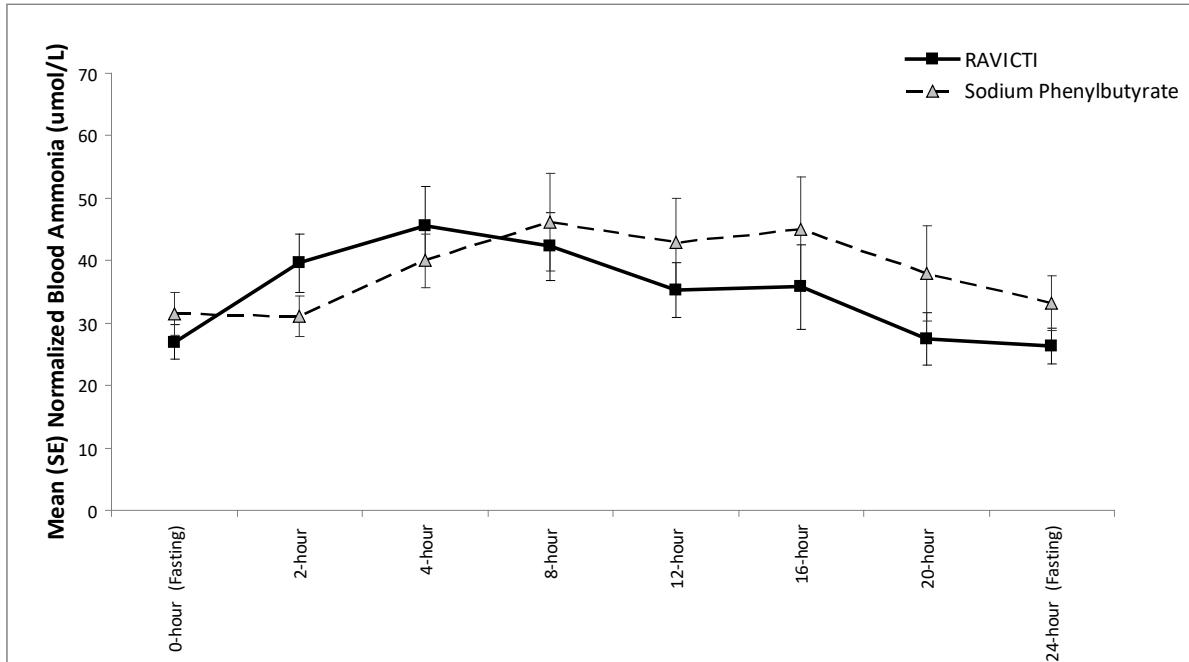

Table 3: Ammonia Levels in Adult Patients with UCDs in Short-Term Treatment Study 1

Timepoint	Ammonia (n=44)	
	Mean (SD)	Median (min, max)
Daily C_{max} (micromol/L)		
RAVICTI	61 (46)	51 (12, 245)
Sodium phenylbutyrate	71 (67)	46 (14, 303)
24-Hour AUC (micromol•h/L)		
RAVICTI	866 (661)	673 (206, 3351)
Sodium phenylbutyrate	977 (865)	653 (302, 4666)

Open-Label, Uncontrolled, Extension Study in Adults

A long-term (12-month), uncontrolled, open-label study (Study 2) was conducted to assess monthly ammonia control and hyperammonemic crisis over a 12-month period. A total of 51 adults were in the study and all but 6 had been converted from sodium phenylbutyrate to RAVICTI. Venous ammonia levels were monitored monthly. Mean fasting ammonia values in adults in Study 2 were within normal limits during long-term treatment with RAVICTI (range: 6 to 30 micromol/L). Of 51 adult patients participating in the 12-month, open-label treatment with RAVICTI, 7 patients (14%) reported a total of 10 hyperammonemic crises. The fasting ammonia measured during Study 2 is displayed in Figure 3. Ammonia values across different laboratories were normalized to a common normal range of 9 to 35 micromol/L.

Figure 3: Ammonia Levels in Adult Patients with UCDs in Long-Term Treatment Study 2

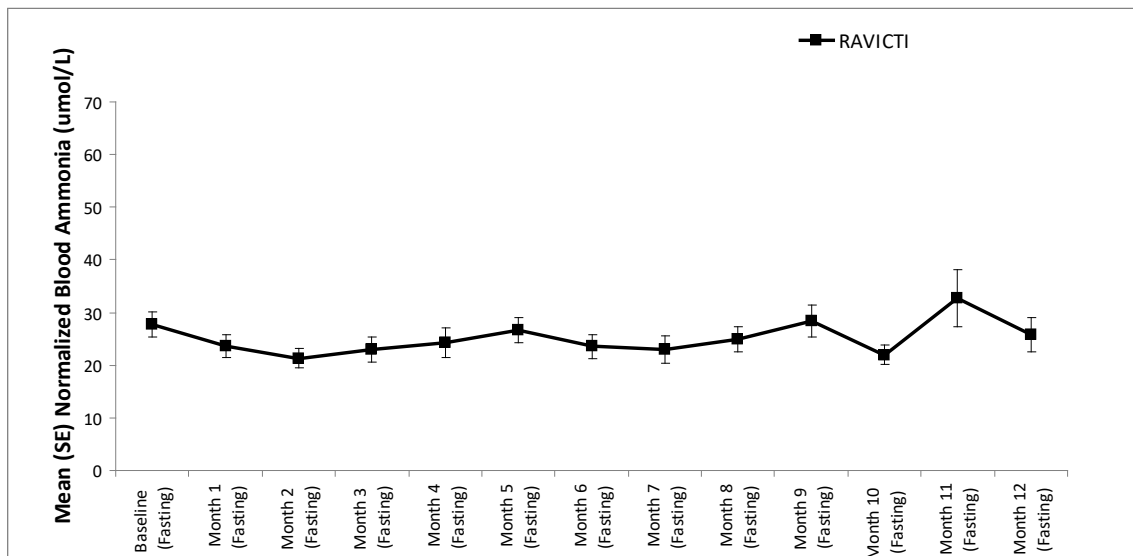

Open-Label, Long-Term Study in Adults

An open-label long-term, study (Study 5) was conducted to assess ammonia control in adult patients with UCDs. The study enrolled patients with UCDs who had completed the safety extensions of Study 1, Study 3 or Study 4 (Study 2, 3E and 4E, respectively). A total of 43 adult patients between the ages of 19 and 61 years were in the study. The median length of study participation was 1.9 years (range 0 to 4.5 years). Venous ammonia levels were monitored at a minimum of every 6 months. Mean fasting ammonia values in adult patients in Study 5 were within normal limits during long-term (24 months) treatment with RAVICTI (range: 24.2 to 31.4 micromol/L). Of the 43 adult patients participating in the open-label treatment with RAVICTI, 9 patients (21%) reported a total of 21 hyperammonemic crises. Ammonia values across different laboratories were normalized to a common normal range of 10 to 35 micromol/L.

14.2 Clinical Studies in Pediatric Patients 2 Years to 17 Years of Age with UCDs

The efficacy of RAVICTI in pediatric patients 2 years to 17 years of age with UCDs was evaluated in 2 fixed-sequence, open-label, sodium phenylbutyrate to RAVICTI switchover studies (Studies 3 and 4). Study 3 was 7 days in duration and Study 4 was 10 days in duration.

These studies compared ammonia levels of patients on RAVICTI to ammonia levels of patients on sodium phenylbutyrate in 26 pediatric patients between 2 months and 17 years of age with UCDs. Four patients less than 2 years of age were excluded from this analysis due to insufficient data. The dose of RAVICTI was calculated to deliver the same amount of PBA as the dose of sodium phenylbutyrate that patients were taking when they entered the trial. Sodium phenylbutyrate or RAVICTI were administered in divided doses with meals. Patients adhered to a low-protein diet throughout the study. After a dosing period with each treatment,

all patients underwent 24 hours of venous ammonia measurements, as well as blood and urine pharmacokinetic assessments.

UCD subtypes included OTC (n=12), ASL (n=8), and ASS deficiency (n=2), and patients received a mean RAVICTI dose of 8 mL/m²/day (8.8 g/m²/day), with doses ranging from 1.4 to 13.1 mL/m²/day (1.5 to 14.4 g/m²/day). Doses in these patients were based on previous dosing of sodium phenylbutyrate.

The 24-hour AUCs for ammonia (AUC_{0-24h}) in 11 pediatric patients 6 years to 17 years of age with UCDs (Study 3) and 11 pediatric patients 2 years to 5 years of age with UCDs (Study 4) were similar between treatments. In pediatric patients 6 years to 17 years of age, the ammonia AUC_{0-24h} was 604 micromol·h/L vs 815 micromol·h/L on RAVICTI vs sodium phenylbutyrate, respectively. In patients between 2 years and 5 years of age with UCDs, the ammonia AUC_{0-24h} was 632 micromol·h/L vs 720 micromol·h/L on RAVICTI versus sodium phenylbutyrate, respectively.

The mean ammonia levels over 24 hours in open-label, short-term Studies 3 and 4 at common time points are displayed in Figure 4. Ammonia values across different laboratories were normalized to a common normal range of 9 to 35 micromol/L using the following formula after standardization of the units to micromol/L:

Normalized ammonia (micromol/L) = ammonia readout in micromol/L x (35/ULN of a laboratory reference range specified for each assay)

Figure 4: Ammonia Levels in Pediatric Patients 2 Years to 17 Years of Age with UCDs in Short-Term Treatment Studies 3 and 4

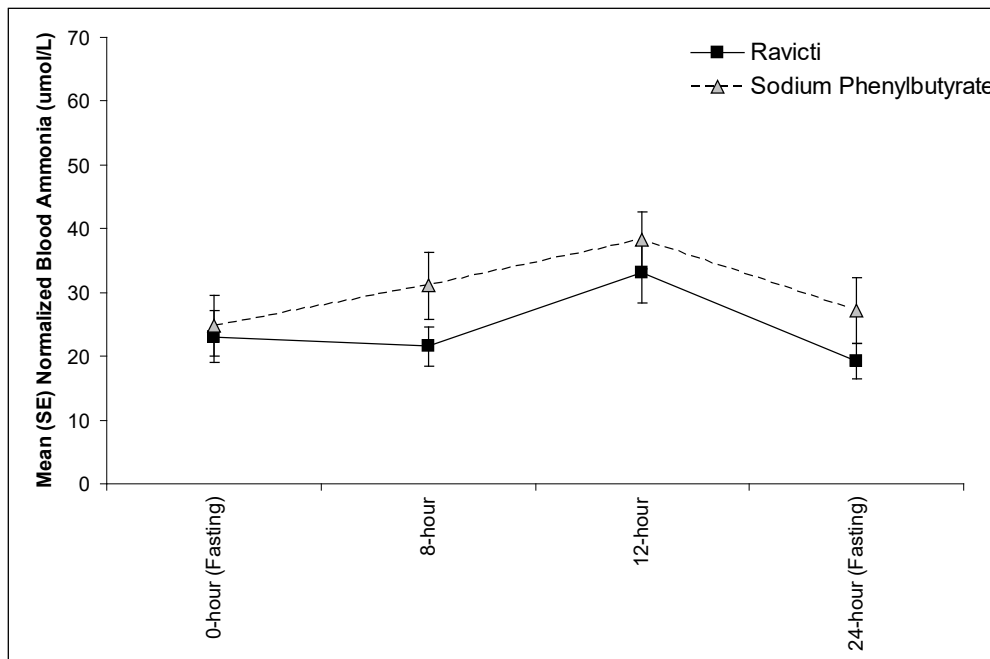

Open-Label, Uncontrolled, Extension Studies in Pediatric Patients 2 Years to 17 Years of Age

Long-term (12-month), uncontrolled, open-label studies were conducted to assess monthly ammonia control and hyperammonemic crises over a 12-month period. In two studies (Study 2, which also enrolled adults, and an extension of Study 3, referred to here as Study 3E), a total of 26 pediatric patients ages 6 years to 17 years were enrolled and all but 1 had been converted from sodium phenylbutyrate to RAVICTI. Mean fasting venous ammonia levels were within normal limits (range 17 to 23 micromol/L) during long-term treatment with RAVICTI. Of the 26 pediatric patients 6 years to 17 years of age participating in these two trials, 5 patients (19%) reported a total of 5 hyperammonemic crises. The fasting ammonia levels measured during these two extension studies in patients 6 years to 17 years are displayed in Figure 5. Ammonia values across different laboratories were normalized to a common normal range of 9 to 35 micromol/L.

Figure 5: Ammonia Levels in Pediatric Patients 2 Years to 17 Years of Age with UCAs in Long-Term Treatment Studies 2 and 3E

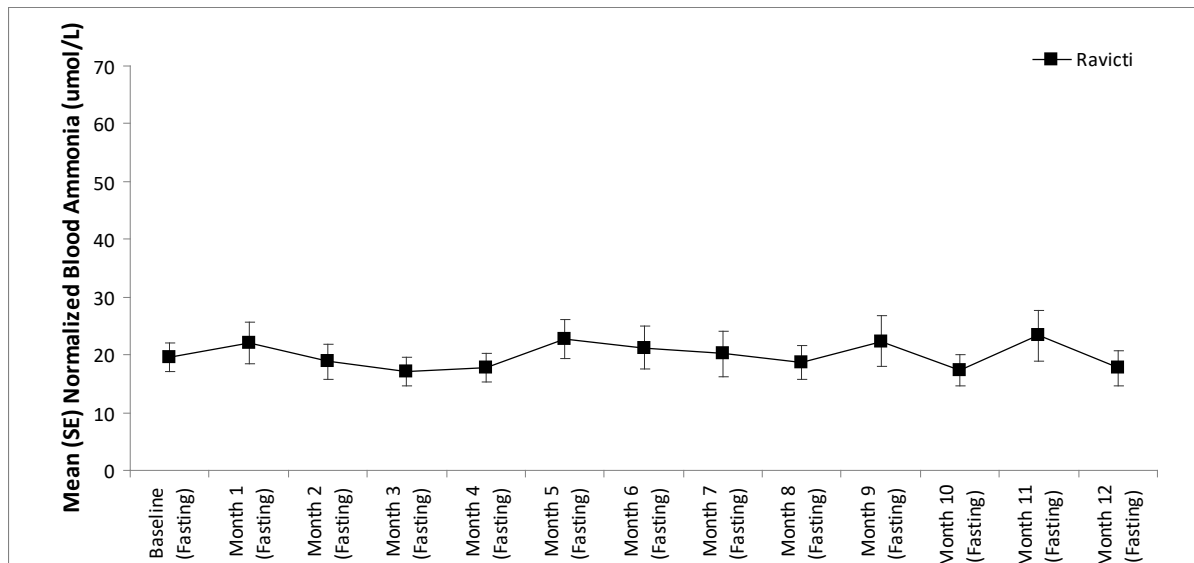

In an extension of Study 4 (referred to as Study 4E), after a median time on study of 4.5 months (range: 1 to 5.7 months), 2 of 16 pediatric patients ages 2 years to 5 years had experienced three hyperammonemic crises.

Open-Label, Long-Term Study in Pediatric Patients 1 Year to 17 Years of Age

An open-label, long-term study (Study 5) was conducted to assess ammonia levels in pediatric patients with UCD. The study enrolled patients with UCAs who had completed Studies 2, 3E and 4E. A total of 45 pediatric patients ages 1 year to 17 years were included in the study. The median length of treatment was 1.7 years (range 0.2 to 4.6 years). Venous ammonia levels were monitored at a minimum every 6 months. Mean ammonia values in pediatric patients in Study 5 were within normal limits during long-term (24 months) treatment with RAVICTI (range: 15.4 to 25.1 micromol/L). Of the 45 pediatric patients participating in the open-label treatment with RAVICTI, 11 patients (24%) reported a total of

22 hyperammonemic crises. Ammonia values across different laboratories were normalized to a common normal range of 10 to 35 micromol/L.

14.3 Clinical Studies in Pediatric Patients Less Than 2 Years of Age with UCDs

The efficacy of RAVICTI in pediatric patients less than 2 years of age with UCDs was evaluated in uncontrolled, open label studies (Studies 4/4E, 5 [*see Clinical Studies (14.2)*] and 6). A total of 17 pediatric patients with UCDs aged 2 months to less than 2 years participated in Studies 4/4E, 5 and 6. Study 6 enrolled 16 pediatric patients less than 2 months of age.

Uncontrolled, Open-Label Studies in Pediatric Patients Aged 2 Months to Less than 2 Years of Age (Studies 4/4E, 5)

A total of 7 patients with UCDs aged 2 months to less than 2 years participated in Studies 4/4E and 5. In these studies, there were 7, 6, 6, 6 and 3 pediatric patients who completed 1, 6, 9, 12 and 18 months, respectively (mean and median exposure of 15 and 17 months, respectively). Patients were converted from sodium phenylbutyrate to RAVICTI. The dosage of RAVICTI was calculated to deliver the same amount of PBA as the sodium phenylbutyrate dosage the patients were taking when they entered the study.

Patients received a mean RAVICTI dose of 7.5 mL/m²/day (8.2 g/m²/day), with doses ranging from 3.3 to 12.3 mL/m²/day (3.7 to 13.5 g/m²/day). Patients were dosed three times per day (n=3) or four times per day (n = 4).

Venous ammonia levels were monitored on days 1, 3, and 10 in Study 4 and at week 1 in Study 4E. Two patients had elevated ammonia values on day 1 of treatment (122 micromol/L and 111 micromol/L respectively) and neither had associated signs and symptoms of hyperammonemia. At day 10/week 1, six of the 7 patients had normal ammonia levels (less than 100 micromol/L) while the remaining patient had an elevated ammonia value on day 10 (168 micromol/L) and was asymptomatic.

During the extension period, venous ammonia levels were monitored monthly. Ammonia values across different laboratories were normalized (transformed) to a common normal pediatric range of 28 to 57 micromol/L for comparability. The mean ammonia levels in pediatric patients at month 1, 3, 6, 9 and 12 were 58, 49, 34, 65, and 31 micromol/L during treatment with RAVICTI, respectively.

Three patients reported a total of 3 hyperammonemic crises defined as having signs and symptoms consistent with hyperammonemia (such as frequent vomiting, nausea, headache, lethargy, irritability, combativeness, and/or somnolence) associated with high ammonia levels (greater than 100 micromol/L) and requiring medical intervention. Hyperammonemic crises were precipitated by gastroenteritis, vomiting, infection or no precipitating event (one patient). There were 4 patients who had one ammonia level that exceeded 100 micromol/L which was not associated with a hyperammonemic crisis.

Uncontrolled, Open-Label Study in Pediatric Patients Less Than 2 Years of Age (Study 6)

Study 6 was an uncontrolled, open label study in pediatric patients less than 2 years of age. The primary efficacy endpoint was successful transition to RAVICTI within a period of 4

days followed by 3 days of observation for a total of 7 days, where successful transition was defined as no signs and symptoms of hyperammonemia and a venous ammonia level less than 100 micromol/L. Ammonia levels were monitored for up to 4 days during transition and on day 7.

Pediatric Patients 2 Months to Less than 2 Years of Age

A total of 10 pediatric patients with UCDs aged 2 months to less than 2 years participated in Study 6, of which 6 patients converted from sodium phenylbutyrate to RAVICTI and 1 patient converted from sodium phenyl butyrate and sodium benzoate. The dosage of RAVICTI was calculated to deliver the same amount of PBA as the sodium phenylbutyrate dosage the patients were taking when they entered the trial. Two patients were treatment-naïve and received RAVICTI dosage of 7.5 mL/m²/day and 9.4 mL/m²/day, respectively. One additional patient was gradually discontinued from intravenous sodium benzoate and sodium phenylacetate while RAVICTI was initiated. The dosage of RAVICTI after transition was 8.5 mL/m²/day.

There were 9, 7, 7, 4, 1 and 4 pediatric patients who completed 1, 3, 6, 12, 18 and 24 months, respectively (mean and median exposure of 9 and 9 months, respectively).

Patients received a mean RAVICTI dose of 8 mL/m²/day (8.8 g/m²/day), with doses ranging from 4.8 to 11.5 mL/m²/day (5.3 to 12.6 g/m²/day). Patients were dosed three times a day (n=6), four times a day (n = 2), or five or more times a day (n=2).

Nine patients successfully transitioned as defined by the primary endpoint. One additional patient developed hyperammonemia on day 3 of dosing and experienced surgical complications (bowel perforation and peritonitis) following jejunal tube placement on day 4. This patient developed hyperammonemic crisis on day 6, and subsequently died of sepsis from peritonitis unrelated to drug. Although two patients had day 7 ammonia values of 150 micromol/L and 111 micromol/L respectively, neither had associated signs and symptoms of hyperammonemia.

During the extension phase, venous ammonia levels were monitored monthly. Ammonia values across different laboratories were normalized (transformed) to a common normal pediatric range of 28 to 57 micromol/L for comparability. The mean normalized ammonia levels in pediatric patients at months 1, 2, 3, 4, 5, 6, 9, 12, 15, 18 and 24 were 67, 53, 78, 93, 78, 67, 38, 38, 36, 48 and 53 micromol/L during treatment with RAVICTI, respectively.

Three patients reported a total of 7 hyperammonemic crises as defined in Study 4/4E and 5. Hyperammonemic crises were precipitated by vomiting, upper respiratory tract infection, gastroenteritis, decreased caloric intake or had no identified precipitating event (3 events). There was one additional patient who had one ammonia level that exceeded 100 micromol/L which was not associated with a hyperammonemic crisis.

Pediatric Patients Less than 2 Months of Age

A total of 16 pediatric patients less than 2 months of age participated in Study 6. Median age at enrollment was 0.5 months (range: 0.1 to 2 months). Eight patients had OTC deficiency, 7 patients had ASS deficiency, and 1 patient had ASL deficiency. Ten of the 16 patients transitioned from sodium phenylbutyrate to RAVICTI within 3 days of treatment and their initial dosage of RAVICTI was calculated to deliver the same amount of phenylbutyrate as

the sodium phenylbutyrate dosage administered prior to RAVICTI dosing. Three of the 16 patients were treatment-naïve and started RAVICTI at dosages of 9, 9.4, and 9.6 mL/m²/day. The remaining 3 of the 16 patients transitioned from intravenous sodium benzoate and sodium phenylacetate to RAVICTI within 3 days of treatment and their initial dosages of RAVICTI were 10.4, 10.9, and 10.9 mL/m²/day.

Of the 16 patients, 16, 14, 12, 6, and 3 patients were treated for 1, 3, 6, 12, and 18 months, respectively.

After the initial 7-day transition period, patients received a mean RAVICTI dosage of 8 mL/m²/day (8.8 g/m²/day), with doses ranging from 3.1 to 12.7 mL/m²/day (3.4 to 14 g/m²/day). The frequency of dosing varied throughout the study. The majority of patients were dosed three times per day with feeding. No patients discontinued during the 7-day transition phase. Ammonia values across different laboratories were normalized (transformed) to a common normal pediatric range of 28 to 57 micromol/L for comparability.

During the safety extension phase (months 1-24), venous ammonia levels were monitored monthly for the first 6 months of treatment and every 3 months thereafter until the patients terminated or completed the study. During the safety extension phase, 1 patient discontinued from the study due to an adverse event (increased hepatic enzymes), 2 patients were withdrawn from the study by their parent/guardian, and 4 patients discontinued from the study early to undergo a liver transplant (protocol-defined discontinuation criterion). The normalized ammonia levels in pediatric patients with available values (which varied by month of treatment) in Study 6 in patients less than 2 months of age are shown in Table 4.

Table 4: Ammonia* Levels in Pediatric Patients Less than 2 Months of Age with UCDs in Study 6

Month	N (patients with available ammonia level)	Normalized Ammonia (micromol/L)**	
		Mean (SD)	Median (Min, Max)
1	15	71 (52)	60 (18, 227)
2	11	58 (40)	50 (16, 168)
3	14	53 (34)	46 (11, 122)
4	11	94 (106)	64 (35, 407)
5	10	52 (18)	57 (27, 86)
6	9	49 (24)	42 (22, 91)
9	8	56 (34)	45 (22, 122)
12	6	35 (17)	36 (11, 60)
15	4	52 (12)	52 (39, 67)
18	3	64 (14)	63 (50, 78)
24	9	63 (29)	72 (23, 106)

*normalized ammonia (micromol/L) = ammonia readout in micromol/L x (35/ULN of a laboratory reference range specified for each assay)

**normal range: 28 to 57 micromol/L.

Five patients (all less than 1 month of age) experienced a total of 7 hyperammonemic crises defined as in Study 4/4E and 5. Hyperammonemic crises were precipitated by upper respiratory tract infection (2 events), change in diet (1 event), or had no identified precipitating event (4 events).

16 HOW SUPPLIED/STORAGE AND HANDLING

RAVICTI® (glycerol phenylbutyrate) oral liquid 1.1 g/mL is supplied in multi-use, 25-mL glass bottles. The bottles are supplied in the following configurations:

- NDC 75987-050-06: Single 25-mL bottle per carton
- NDC 75987-050-07: Four 25-mL bottles per carton

Store at 20°-25°C (68°-77°F) with excursions permitted to 15°-30°C (59°-86°F).

17 PATIENT COUNSELING INFORMATION

Advise the patient to read the FDA-approved patient labeling (Medication Guide).

Neurotoxicity [see Warnings and Precautions (5.1)].

- Inform patients/caregivers that adverse reactions of RAVICTI are sometimes the same as symptoms of high blood ammonia. Neurological adverse reactions may also be associated with the major metabolite of RAVICTI, PAA, and may be reversible. Blood tests for PAA may be done to measure the amount of PAA in the blood. Instruct the patient/caregiver to contact the healthcare provider immediately if the patient experiences: nausea, vomiting, headache, fatigue, somnolence, lightheadedness, confusion, exacerbation of preexisting neuropathy, disorientation, impaired memory, dysgeusia, or hypoacusis.

Pregnancy Registry

Advise patients that there is a pregnancy exposure registry that monitors pregnancy outcomes in women exposed to RAVICTI during pregnancy [see Use in Specific Populations (8.1)].

Lactation

Advise patients that breastfeeding is not recommended during treatment with RAVICTI [see Use in Specific Populations (8.2)].

Administration

- Instruct patients to take RAVICTI with food or formula and to administer directly into the mouth via oral syringe or dosing cup.
- Instruct that RAVICTI should be administered just prior to breastfeeding in infants who are breastfeeding.
- Instruct patients to take RAVICTI orally, even if they have a nasogastric and/or gastrostomy tube. For patients who cannot swallow and who have a nasogastric tube or gastrostomy tube in place, instruct patients/caregivers to administer RAVICTI as follows:

- Utilize an oral syringe to withdraw the prescribed dosage of RAVICTI from the bottle.
- Place the tip of the syringe into the gastrostomy/nasogastric tube.
- Utilizing the plunger of the syringe, administer RAVICTI into the tube.
- Flush once with 10 mL of water or formula and allow the flush to drain.
- If needed, flush a second time with an additional 10 mL of water or formula to clear the tube.

Distributed by:

Horizon Pharma USA, Inc.

Lake Forest, IL 60045

Horizon Therapeutics, LLC.



All rights reserved.

RAVICTI is a registered trademark of Horizon Therapeutics, LLC.

MEDICATION GUIDE
RAVICTI (rah-VIK- tee)
(glycerol phenylbutyrate)
oral liquid

What is the most important information I should know about RAVICTI?

RAVICTI may cause serious side effects, including:

Nervous system problems (Neurotoxicity). Phenylacetate (PAA), a breakdown product of RAVICTI, may cause nervous system side effects. Call your doctor or get medical help right away if you get any of these symptoms while taking RAVICTI:

- sleepiness
- lightheadedness
- change in taste
- problems with hearing
- confusion
- problems with memory
- worsening of numbness, tingling, or burning in your hands or feet
- headache
- feeling very tired (fatigue)
- nausea
- vomiting

Your doctor may do blood tests to measure the amount of PAA in your blood during your treatment with RAVICTI.

What is RAVICTI?

- RAVICTI is a prescription medicine used for long-term management of high blood levels of ammonia (hyperammonemia) caused by a condition called a urea cycle disorder (UCD). RAVICTI should be used if the UCD cannot be managed with a low protein diet and dietary supplements alone. RAVICTI must be used along with a low protein diet and in some cases dietary supplements.
- RAVICTI is not used for the acute treatment of hyperammonemia in people with UCD.
- It is not known if RAVICTI is safe and effective for the treatment of N-acetylglutamate synthase (NAGS) deficiency.

Who should not take RAVICTI?

- Do not take RAVICTI if you are allergic to phenylbutyrate. Call your doctor or go to the nearest hospital emergency room if you have wheezing, shortness of breath, cough, low blood pressure, flushing, nausea or a rash while taking RAVICTI.

Before taking RAVICTI, tell your doctor about any medical conditions and if you:

- Have liver or kidney problems.
- Have pancreas or bowel (intestine) problems.
- Are pregnant or plan to become pregnant. It is not known if RAVICTI will harm your unborn baby.
 - **Pregnancy Registry:** There is a Pregnancy Registry for women who take RAVICTI just before becoming pregnant or who become pregnant during treatment with RAVICTI. The purpose of this registry is to collect information about the health of you and your baby. Talk to your doctor about how you can join the Pregnancy Registry. For more information about this registry, call 1-855-823-2595 or visit www.ucdregistry.com.
- Are breastfeeding or plan to breastfeed. It is not known if RAVICTI passes into your breast milk. Breastfeeding is not recommended during treatment with RAVICTI. Talk to your doctor about the best way to feed your baby if you take RAVICTI.

Tell your doctor about all the medicines you take, including prescription and over-the-counter medicines, vitamins, dietary and herbal supplements.

Know the medicines you take. Keep a list of them to show your doctor and pharmacist when you get a new medicine.

How should I take RAVICTI?

- Take RAVICTI exactly as your doctor tells you.
- Your doctor will tell you how much RAVICTI to take and when to take it.
- Your doctor may change your dose if needed.
- Take RAVICTI with food or formula.
- In an infant who is breastfeeding, give RAVICTI just before breastfeeding.
- RAVICTI is an oral liquid that is taken by mouth using an oral syringe or dosing cup. Ask your pharmacist for an oral syringe or dosing cup if you do not have one.
- If you have a nasogastric or gastrostomy tube in place and can swallow, you should take RAVICTI by mouth.
- Stay on the diet that your doctor gives you.
- If you take too much RAVICTI, call your doctor or your poison control center at 1-800-222-1222 or go to the nearest hospital emergency room right away.

For people who cannot swallow and who have a nasogastric or gastrostomy tube in place, RAVICTI should be given as follows:

- Use an oral syringe to withdraw the prescribed dose of RAVICTI from the bottle.
- Place the tip of the syringe into the nasogastric or gastrostomy tube and push the plunger of the syringe to give RAVICTI into the tube.

- Add 10 mL of water or formula to the syringe and push the plunger of the syringe to flush any remaining medicine from the nasogastric or gastrostomy tube into the stomach.
- If needed, flush the nasogastric or gastrostomy tube again with 10 mL of water or formula to clear the nasogastric or gastrostomy tube.

What are the possible side effects of RAVICTI?

RAVICTI may cause serious side effects, including:

- See “What is the most important information I should know about RAVICTI?”

The most common side effects of RAVICTI in adults include:

- | | |
|--------------------------|----------------------------|
| • diarrhea | • vomiting |
| • gas | • tiredness |
| • headache | • decreased appetite |
| • abdomen (stomach) pain | • indigestion or heartburn |

The most common side effects of RAVICTI in children 2 years to 17 years of age include:

- | | |
|--------------------------------|----------------------|
| • upper abdomen (stomach) pain | • diarrhea |
| • rash | • decreased appetite |
| • nausea | • headache |
| • vomiting | |

The most common side effects of RAVICTI in children 2 months to less than 2 years of age include:

- | | |
|--|---------------------------------|
| • low white blood cell count (neutropenia) | • cough |
| • vomiting | • stuffy nose |
| • constipation | • runny nose |
| • diarrhea | • skin rash |
| • fever | • small round bumps on the skin |
| • reduced food intake | |

The most common side effects of RAVICTI in children less than 2 months of age include:

- | | |
|--|---|
| • vomiting | • low blood neutrophil count (type of white blood cell) (neutropenia) |
| • rash | • high blood white blood cell count (lymphocytosis) |
| • gastroesophageal reflux | • diarrhea |
| • increased levels of liver enzymes in the blood | • gas |
| • decreased appetite and reduced food intake | • constipation |
| • low red blood cell count (anemia) | • fever |
| • cough | • drowsiness (lethargy) |
| • loss of too much body fluid (dehydration) | • irritability |
| • too much acid in the blood (acidosis) | • agitation |
| • high blood platelet count (thrombocytosis) | |
| • low blood platelet count (thrombocytopenia) | |

Tell your doctor if you have any side effect that bothers you or that does not go away. These are not all of the possible side effects of RAVICTI.

Call your doctor for medical advice about side effects. You may report side effects to FDA at 1-800-FDA-1088.

How should I store RAVICTI?

- Store RAVICTI between 68°F to 77°F (20°C to 25°C).

Keep RAVICTI and all medicines out of the reach of children.

General information about the safe and effective use of RAVICTI.

Medicines are sometimes prescribed for purposes other than those listed in a Medication Guide. Do not use RAVICTI for a condition for which it was not prescribed. Do not give RAVICTI to other people, even if they have the same symptoms you have. It may harm them.

You can ask your doctor or pharmacist for information about RAVICTI that is written for health professionals.

What are the ingredients in RAVICTI?

Active ingredient: glycerol phenylbutyrate

Distributed by: Horizon Pharma USA, Inc., Lake Forest, IL 60045.

© Horizon Therapeutics, LLC. All rights reserved. RAVICTI is a registered trademark of Horizon Therapeutics, LLC.

For more information, go to www.RAVICTI.com or call 1-855-823-7878.

This Medication Guide has been approved by the U.S. Food and Drug Administration.

Revised: October 2019

PRODUCT MONOGRAPH

PrRESTASIS®

Cyclosporine

Ophthalmic Emulsion, 0.05% w/v

Anti-Inflammatory / Immunomodulator

Allergan Inc.
Markham, Ontario
L6G 0B5

Date of Revision:
October 03, 2012

Submission Control #157208

Table of Contents

PART I: HEALTH PROFESSIONAL INFORMATION.....3
SUMMARY PRODUCT INFORMATION3
INDICATIONS AND CLINICAL USE.....3
CONTRAINDICATIONS3
WARNINGS AND PRECAUTIONS.....4
ADVERSE REACTIONS.....5
DRUG INTERACTIONS7
DOSAGE AND ADMINISTRATION7
OVERDOSAGE8
ACTION AND CLINICAL PHARMACOLOGY9
STORAGE AND STABILITY9
DOSAGE FORMS, COMPOSITION AND PACKAGING9

PART II: SCIENTIFIC INFORMATION11
PHARMACEUTICAL INFORMATION.....11
CLINICAL TRIALS.....11
DETAILED PHARMACOLOGY15
TOXICOLOGY20
REFERENCES26

PART III: CONSUMER INFORMATION.....28

Pr RESTASIS®

Cyclosporine

PART I: HEALTH PROFESSIONAL INFORMATION

SUMMARY PRODUCT INFORMATION

Route of Administration	Dosage Form / Strength	Clinically Relevant Nonmedicinal Ingredients
Ophthalmic	Emulsion, 0.05% w/v	Castor oil <i>For a complete listing see Dosage Forms, Composition and Packaging section.</i>

INDICATIONS AND CLINICAL USE

RESTASIS® (cyclosporine) ophthalmic emulsion, 0.05% w/v is indicated for the treatment of moderate to moderately severe (Level 2-3 severity by DEWS Guidelines)¹ aqueous deficient dry eye disease, characterized by moderate to moderately severe: ocular staining, reduction in tear production and fluctuating visual symptoms, such as blurred vision. This indication is based on a pooled analysis of a subpopulation of patients from three pivotal studies (see CLINICAL TRIALS for further information).

The efficacy of RESTASIS® alone has not been demonstrated in patients with more severe disease (Level 4 DEWS Classification).

Geriatrics (> 65 years of age):

No overall difference in safety or effectiveness has been observed between elderly and younger subjects.

Paediatrics (<18 years of age):

No paediatric data are available.

CONTRAINDICATIONS

- Patients who are hypersensitive to this drug or to any ingredient in the formulation or component of the container. For a complete listing, see the Dosage Forms, Composition and Packaging section of the product monograph.
- Patients with active ocular infections

¹ Report of the International Dry Eye WorkShop (DEWS). The Ocular Surface, April 2007; 5(2):65-204.

WARNINGS AND PRECAUTIONS

General

For ophthalmic use only.

Carcinogenesis and Mutagenesis

See Toxicology.

Ophthalmologic

RESTASIS® (cyclosporine) ophthalmic emulsion, 0.05% w/v has not been studied in patients with a history of *herpes keratitis*, end stage lacrimal gland disease, *keratoconjunctivitis sicca* (KCS) secondary to the destruction of conjunctival goblet cells such as occurs with Vitamin A deficiency, or scarring, such as occurs with cicatricial pemphigoid, alkali burns, Stevens Johnson syndrome, trachoma, or irradiation.

Patients should be advised to avoid touching the tip of the vial to the eye or any surface, as this may contaminate the emulsion. To avoid the potential for injury to the eye, patients should be advised to be careful not to touch the vial container to the eye.

RESTASIS® should not be administered while the patient is wearing contact lenses. If contact lenses are worn, they should be removed prior to the administration of the emulsion. Lenses may be reinserted 15 minutes after the administration of RESTASIS®.

Immune

There is the potential to experience hypersensitivity to RESTASIS®. Reactions of severe angioedema, face swelling, tongue swelling, pharyngeal edema, dyspnea and urticaria have been reported with the use of RESTASIS® (See Post-market Adverse Drug Reactions). If an allergic reaction occurs, patients should be advised to discontinue the drug.

Occupational Hazards

RESTASIS® may cause transient blurred vision due to its emulsion formulation. If patients experience blurred vision, they should be advised not to drive or operate machinery until vision has cleared.

Special Populations

Pregnant Women: There are no adequate data from the use of RESTASIS® in pregnant women. Studies in animals have shown reproductive toxicity at high maternotoxic doses. See Toxicology.

RESTASIS® should not be used during pregnancy unless the benefits outweigh the risks.

Nursing Mothers: Cyclosporine is known to be excreted in human milk following systemic administration, but excretion in human milk after topical administration has not been

investigated. Although blood concentrations are undetectable after topical administration of RESTASIS®, caution should be exercised when RESTASIS® is administered to a nursing woman.

Paediatric Use: The safety and efficacy of RESTASIS® have only been studied in adults.

Geriatric Use: No overall difference in safety or effectiveness has been observed between elderly and younger patients.

ADVERSE REACTIONS

Adverse Drug Reaction Overview

The most common adverse event following the use of RESTASIS® (cyclosporine) ophthalmic emulsion, 0.05% w/v is ocular burning.

Clinical Trial Adverse Drug Reactions

Because clinical trials are conducted under very specific conditions, the adverse reaction rates observed in the clinical trials may not reflect the rates observed in practice and should not be compared to the rates in the clinical trials of another drug. Adverse drug reaction information from clinical trials is useful for identifying drug-related adverse events and for approximating rates.

In the combined data from the three key Phase 3 clinical studies, approximately 29% of treated patients experienced treatment-related adverse events (adverse reactions) in the first year. The majority were ocular, mild or moderate in severity, and none was serious. The most commonly reported adverse reaction was eye burning, which was reported in approximately 17% of patients in the first year; the incidence of new reports decreased to 5% at 2 years. The observed adverse drug reactions are provided below for those events observed at an incidence of $\geq 1\%$ in the three vehicle-controlled clinical trials.

Table 1: Vehicle Controlled Clinical Trial Treatment-Related Adverse Drug Reactions Reported by $\geq 1\%$ of Patients in the Cyclosporine 0.05% Treatment Group (ITT Population – Month 12 Pooled Data for Studies 192371-002, -003, -501)

Reported Term	Cyclosporine Ophthalmic Emulsion 0.05% N=436 (%)	Vehicle/Cyclosporine 0.1%	
		6 month Controlled Phase - Vehicle N=442 (%)	6 month Extension Phase – Cyclosporine 0.1% N=323 (%)
Special Senses			
Burning eye	74 (17.0%)	29 (6.6%)	21 (6.5%)
Irritation eye	13 (3.0%)	7 (1.6%)	5 (1.5%)
Foreign body sensation	12 (2.8%)	8 (1.8%)	2 (0.6%)
Hyperaemia conjunctival (NOS)	11 (2.5%)	9 (2.0%)	7 (2.2%)
Pain eye	10 (2.3%)	11 (2.5%)	5 (1.5%)
Stinging eye	10 (2.3%)	9 (2.0%)	7 (2.2%)
Discharge eye	9 (2.1%)	7 (1.6%)	1 (0.3%)
Photophobia	9 (2.1%)	3 (0.7%)	-
Pruritus eye	8 (1.8%)	7 (1.6%)	2 (0.6%)
Visual disturbance	8 (1.8%)	12 (2.7%)	1 (0.3%)
Dry eye	7 (1.6%)	2 (0.5%)	-
Body as a Whole			
Headache	7 (1.6%)	5 (1.1%)	2 (0.6%)

*Note that active events are reported over 12 months; vehicle events are reported for 6 month exposure period.
NOS – not otherwise specified*

The frequency of all adverse event reporting was generally highest shortly after initiation of RESTASIS® treatment, but lessened as treatment continued.

Less Common Clinical Trial Adverse Drug Reactions (<1%)

The observed adverse drug reactions are provided below for those events reported by <1% of patients in the cyclosporine 0.05% treatment group in the three vehicle-controlled clinical trials over 12 months.

Digestive System: dryness oral, nausea, salivary gland enlargement, stomatitis ulcer

Musculoskeletal System: arthralgia

Nervous System: dizziness

Respiratory System: rhinitis, infection sinus

Skin: rash, alopecia

Special Senses: conjunctivitis (NOS), oedema eyelid, blepharitis, erythema eyelid, asthenopia, chalazion, conjunctivitis bacterial, corneal abrasion, corneal infiltrates, corneal neovascularisation, eczema eyelid, oedema eye, conjunctival haemorrhage, keratitis herpes simplex, keratitis superficial punctate, lacrimation increased, pain ear, ulcer corneal (NOS), ulcerative keratitis, vitreous floaters

Post-Market Adverse Drug Reactions

Post-marketing reactions reported to date have been consistent with the events recorded during the vehicle-controlled clinical trials, with the majority of the reported events being ocular. Adverse reactions detected in post-marketing data but not seen with cyclosporine ophthalmic emulsion, 0.05% in clinical trials include eye swelling; hypersensitivity including severe angioedema, face swelling, tongue swelling, pharyngeal edema, dyspnea, urticaria; burning sensation; pruritus; superficial injury of the eye (from the vial touching the eye during administration).

DRUG INTERACTIONS

Overview

No interaction studies have been performed.

Drugs that affect cytochrome P-450 may alter cyclosporine metabolism. There is no detectable systemic absorption of RESTASIS® (cyclosporine) ophthalmic emulsion, 0.05% w/v following ocular administration. Therefore, no interaction of topically applied RESTASIS® with systemic drugs is expected to occur.

Drug-Drug Interactions

Interactions with other drugs have not been established.

Drug-Food Interactions

Interactions with food have not been established.

Drug-Herb Interactions

Interactions with herbal products have not been established.

Drug-Laboratory Interactions

Interactions with laboratory tests have not been established.

DOSAGE AND ADMINISTRATION

Dosing Considerations

There are no special dosing considerations which need to be taken into account prior to initiating therapy with RESTASIS® (cyclosporine) ophthalmic emulsion, 0.05% w/v.

Recommended Dose and Dosing Adjustment

The recommended dose is one drop of RESTASIS®, instilled twice a day in each eye approximately 12 hours apart.

This recommended dose is the maximum recommended dose, and should be used both as the starting dose and throughout long term treatment. Dosage adjustments should not be necessary based on any co-morbid conditions, given the low systemic availability of the product. Limited

data from clinical studies exists for long term administration of RESTASIS® (up to 40 months). It is expected that use of the product will continue long term.

Administration

The vial should be inverted a few times to obtain a uniform, white, opaque emulsion before using.

The emulsion from one individual single-use vial is to be used immediately after opening for administration to one or both eyes, and the remaining contents should be discarded immediately after administration.

Patients should be advised to avoid touching the tip of the vial to the eye or any surface, as this may contaminate the emulsion. To avoid the potential for injury to the eye, patients should also be advised not to touch the vial container to the eye.

RESTASIS® should not be administered while the patient is wearing contact lenses. If contact lenses are worn, they should be removed prior to the administration of the emulsion. Lenses may be reinserted 15 minutes after the administration of RESTASIS®.

RESTASIS® may be used concomitantly with artificial tears. The patient should be advised to allow a 15 minute interval between administration of RESTASIS® and the artificial tear product.

Missed Dose

If a dose of this medication is missed, it should be taken as soon as possible. However, if it is almost time for the next dose, the missed dose should be skipped and the regular dosing schedule resumed. Doses should not be doubled. The dose should not exceed two drops in the affected eye(s) daily.

OVERDOSAGE

There is no experience with overdose in humans using topical cyclosporine ophthalmic emulsion. Excessive topical use of cyclosporine ophthalmic emulsion would not be expected to contribute to any ocular toxicity. Due to low systemic concentrations of cyclosporine after topical treatment with the ophthalmic emulsion, the likelihood of systemic intoxication from topical overdose is remote.

A single vial of 0.05% cyclosporine emulsion contains 0.2 mg of cyclosporine. The recommended weight-normalized starting dose of NEORAL® (cyclosporine), which is administered systemically for rheumatoid arthritis and plaque psoriasis, is 2.0 mg/kg/day. Therefore, the dose ingested by drinking the contents of an entire vial by a child weighing 14 kg (30 lb) would be approximately 140 times lower than the recommended starting dose of NEORAL®.

In case of suspected overdose, particularly accidental oral ingestion, contact your regional Poison Control Centre.

ACTION AND CLINICAL PHARMACOLOGY

Mechanism of Action

Cyclosporine is an immunosuppressive agent when administered systemically.

In patients whose tear production is presumed to be suppressed due to ocular inflammation associated with *keratoconjunctivitis sicca* (KCS), cyclosporine emulsion is thought to act as a partial immunomodulator. The exact mechanism of action is not known.

Pharmacodynamics

The administration of higher concentrations of cyclosporine emulsion was not found to improve the clinical response.

Pharmacokinetics

Blood cyclosporin A concentrations were measured using a specific high pressure liquid chromatography-mass spectrometry assay. Blood concentrations of cyclosporine A, in all the samples collected, after topical administration of cyclosporine ophthalmic emulsion 0.05% twice daily in humans for up to 12 months, were below the quantitation limit of 0.1 ng/mL. These levels are more than 6550 times lower than those measured during systemic cyclosporine treatment for non-life-threatening indications. There was no detectable drug accumulation in blood during 12 months of treatment with cyclosporine ophthalmic emulsion.

Special Populations and Conditions

Hepatic and Renal Insufficiency: Based on the low systemic availability of cyclosporine administered as ophthalmic emulsion, and as there was no detectable drug accumulation in blood during 12 months of treatment with RESTASIS® (cyclosporine) ophthalmic emulsion, 0.05% w/v, no increased risk in patients with impaired renal or hepatic function would be expected to occur following the use of RESTASIS®.

STORAGE AND STABILITY

RESTASIS® (cyclosporine) ophthalmic emulsion, 0.05% w/v should be stored at 15°-25°C. Patients should be instructed to keep unused vials within the resealable tray.

DOSAGE FORMS, COMPOSITION AND PACKAGING

RESTASIS® (cyclosporine) ophthalmic emulsion, 0.05% w/v is available as a sterile preservative-free emulsion supplied in low density polyethylene single use vials containing 0.4 mL each, packaged in trays containing 30 vials.

Each mL of emulsion contains cyclosporine 0.5 mg with the following non-medicinal ingredients: Carbomer Copolymer Type A, castor oil, glycerin, polysorbate 80, purified water and sodium hydroxide to adjust the pH.

PART II: SCIENTIFIC INFORMATION

PHARMACEUTICAL INFORMATION

Drug Substance

Proper Name: Cyclosporine

Chemical Name: Cyclo[[*(E)*-(2*S*,3*R*,4*R*)-3-hydroxy-4-methyl-2-(methylamino)-6-octenoyl]-L-2-aminobutyryl-*N*-methylglycyl-*N*-methyl-L-leucyl-L-valyl-*N*-methyl-L-leucyl-L-alanyl-D-alanyl-*N*-methyl-L-leucyl-*N*-methyl-L-leucyl-*N*-methyl-L-valyl]

Molecular Formula: C₆₂H₁₁₁N₁₁O₁₂

Molecular Mass: 1202.6

Structural Formula:

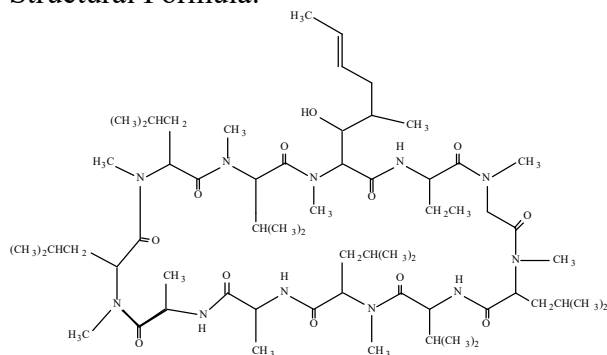

Physicochemical Properties: Cyclosporine is a fine white or almost white powder, practically insoluble in water. Its melting point is 148-151°C.

CLINICAL TRIALS

Study demographics and trial design

Details on the patient demographics for the three key vehicle-controlled studies conducted in patients with moderate to severe *keratoconjunctivitis sicca* are provided in Table 2 on the following page. All studies were conducted with cyclosporine emulsion administered via the ophthalmic route on a twice daily schedule. In these Phase 3 studies, 1315 patients with moderate to severe *keratoconjunctivitis sicca* were included in the ITT population. Patient age ranged from 18.4 to 90.3 years, with a mean age (\pm SD) across studies of 58.6 ± 14.0 years. There were more women (82.7%, 1087/1315) than men (17.3%, 228/1315) and the study population was primarily Caucasian (88.2%, 1160/1315).

Table 2 – Summary of patient demographics for clinical trials in patients with moderate to severe *keratoconjunctivitis sicca*

Study #	Trial Design	Dosage, Route of Administration, and Duration ¹	Study Subjects in ITT Population	Mean Age (range)	Gender, # M/F (%)
002	Multicenter, double masked, randomized, vehicle-controlled, parallel-group	0.05%, 0.1% cyclosporine, or vehicle twice daily 12 months (6 month vehicle controlled & 6 month cyclosporine treatment extension)	405	59.3 (21.6 – 90.3)	87 / 318 (21.5 / 78.5)
003	Multicenter, double masked, randomized, vehicle	0.05%, 0.1% cyclosporine, or vehicle twice daily 12 months (6 month vehicle controlled & 6 month cyclosporine treatment extension)	472	59.8 (24.0 – 90.3)	75 / 397 (15.9 / 84.1)
501	Multicenter, double masked, randomized, vehicle	0.05%, 0.1% cyclosporine, or vehicle twice daily 24 months (6 month vehicle controlled & 18 month cyclosporine treatment extension)	438	56.8 (18.4 – 88.3)	66 / 372 (15.1 / 84.9)

¹In all studies, vehicle patients were switched to 0.1% cyclosporine for the treatment extension period

In these studies, after an initial masked treatment phase of 6 months duration, all patients were eligible to continue on cyclosporine therapy (those allocated to vehicle in the initial treatment phase were switched to cyclosporine 0.1% in a masked manner).

The study design for all three studies comprised a 2-week run-in phase, when patients were instructed to stop using their concurrently used KCS medication and use only REFRESH® in both eyes as needed. Those patients still meeting the strict entry criteria at this point entered a 6-month vehicle-controlled masked treatment phase. In this phase, patients were randomly assigned to 0.05% or 0.1% cyclosporine or their common vehicle (containing 1.25% castor oil), 1 drop in each eye twice daily for 6 months.

REFRESH® use could continue during this treatment phase. However, patients were asked to discontinue REFRESH® use 1 week before the Month 4 visit and to try to restrict REFRESH® usage subsequent to this visit for the remainder of the trial to less than 8 times daily. Visits and evaluations during the masked treatment phase were made at baseline, and at Months 1, 3, 4 and 6.

Although many findings in each of the individual clinical trials showed numerical superiority for cyclosporine over vehicle, the relatively large standard deviations encountered meant that statistical significance was not usually demonstrated. As the three key studies were identical in

design and similar in the study inclusion/exclusion criteria, a *post hoc* meta-analysis was planned and conducted.

The meta-analysis evaluated efficacy in a subpopulation of the three key studies characterized as having Level 2 – Level 3 dry eye disease. This classification was based on the Dry Eye Workshop (DEWS) guidelines (2007), and focused on the population most likely to benefit from therapy with cyclosporine 0.05%, as it was realized after the trials began that severe cases (Level 4 of the DEWS Classification) may not be improved with cyclosporine alone. The Level 2-3 population was comprised of the subset of the ITT population with all of the following baseline scores:

- corneal staining score of 2-4 and
- total staining score of 5-9 and
- Schirmer’s with anesthesia score > 2 mm/5 min and
- blurred vision score ≤ 2

The co-primary endpoints for the meta-analysis were absence of total ocular surface staining (cornea plus conjunctiva) and absence of blurred vision at Month 6. The secondary efficacy endpoint was Schirmer’s with anesthesia responders. In the latter, a responder was defined as a patient with an increase from baseline ≥ 10 mm/5 min at Month 6 (Month 6 minus baseline).

At Month 6, depending on the endpoint, the difference in proportion of responders between the cyclosporine and vehicle groups ranged from approximately 9 – 12% (see Table 4).

Table 3 – Summary of patient demographics for pooled analysis in patients with Level 2- 3 dry eye disease (cyclosporine 0.05% and vehicle only)

Study #	Trial Design	Dosage, Route of Administration, and Duration	Study Subjects in ITT Level 2-3 Population ¹	Mean Age (range) ¹	Gender, # M/F (%) ¹
002/003/501	Multicenter, double masked, randomized, vehicle-controlled, parallel-group	0.05%, 0.1% cyclosporine, or vehicle twice daily 6 month vehicle controlled phase	316	60.6 (25– 90)	67 / 249 (21.2 / 78.8)

¹Includes only those patients who received cyclosporine 0.05% or vehicle only

Table 4 – Results for ITT Level 2-3 patients at Month 6

Study #	Endpoint	Proportion of Patients with a Score of 0 (N)		P value Relative Risk [95% CI]
		Cyclosporine 0.05%	Vehicle	
002/003/501	<u>Primary</u> Total Staining Responder	12.0% (17/142)	3.1% (5/160)	0.003 3.8 [1.46, 9.89]
	Blurred Vision Responders	49.6% (70/141)	37.7% (60/159)	0.036 1.32 [1.02, 1.71]
	<u>Secondary</u> Schirmer's with Anesthesia Responders	17.1% (22/129)	6.2% (9/146)	0.005 2.68 [1.30, 5.52]

Total Staining Responders: A complete staining responder was defined as a patient with Total Staining = 0 at the Month 6 evaluation.

The distribution of total staining scores at baseline in the pooled studies (002/003/501) was similar in the cyclosporine 0.05% and vehicle groups ($p = 0.678$). The mean total staining score at baseline for each of the two treatment groups was 6.4.

A statistically significantly greater proportion of patients in the cyclosporine 0.05% group were total staining responders compared to the vehicle group at Month 6 (12.0% vs. 3.1%; $p = 0.003$)

Blurred Vision Responders: A complete blurred vision responder was defined as a patient with blurred vision = 0 at the Month 6 evaluation. As patients did not require blurred vision for entry, a responder could include those patients whose blurred vision resolved or who had not developed blurred vision at Month 6.

The distribution of blurred vision scores at baseline in the 3 pooled studies was similar in the cyclosporine 0.05% and vehicle groups ($p = 0.868$). The percentages of patients with blurred vision scores at baseline of 2, 1, and 0 were 43.2%, 26.4%, and 30.4%, respectively, for the cyclosporine 0.05% group and 46.4%, 21.4%, and 32.1%, respectively, for the vehicle group.

A statistically significantly greater proportion of patients in the cyclosporine 0.05% group were blurred vision responders compared to the vehicle group at Month 6 (49.6% vs. 37.7%; $p = 0.036$)

Schirmer's with Anesthesia Score Responders: A complete responder was defined as a patient with an increase from baseline of ≥ 10 mm/5 min at Month 6 (Month 6 minus baseline).

The Schirmer's with anesthesia score at baseline in the pooled studies was similar in the cyclosporine 0.05% and vehicle groups ($p = 0.494$). Mean Schirmer's with anesthesia score at baseline was 6.2 for the cyclosporine 0.05% group and 6.5 for the vehicle treatment group.

A statistically significantly greater proportion of patients in the cyclosporine 0.05% group were Schirmer's with anesthesia responders compared to the vehicle group at Month 6 (17.1% vs. 6.2%; $p = 0.005$).

The results of the meta-analysis of the three key clinical studies consistently demonstrated statistically significant differences at Month 6 favoring cyclosporine 0.05% for the two co-primary endpoints: the proportion of patients with complete resolution of their total ocular surface staining and the proportion of patients not reporting blurred vision. These results are supported by statistically significant differences in the proportion of patients with a marked improvement in tear production, the key secondary endpoint.

Analysis by Underlying Disease (with/without Sjogren's Syndrome):

The subgroup analysis by underlying disease of the Level 2-3 severity population from the three key studies demonstrated that treatment with cyclosporine 0.05% had greater benefits in patients with Sjogren's syndrome compared to vehicle (Total Staining Responders: 17.1% (7/41) vs. 0% (0/34), respectively; $p = 0.014$). An improvement in total staining responders was observed in patients without Sjogren's Syndrome, however, the difference between cyclosporine 0.05% and vehicle was less and not statistically significant (9.9% (10/101) vs. 4.0% (5/126), respectively; $p = 0.072$).

DETAILED PHARMACOLOGY

Pharmacology

Topical use of cyclosporine exerts a local effect, only, and its action is termed immunomodulatory.

Immunomodulation

Topical administration of cyclosporine (0.05% or 0.1%) results in suppression of T-cell activation at an early stage (G0 – G1 transition) and inhibition of pro-inflammatory cytokine secretion within the tissues of the ocular surface (conjunctiva and accessory lacrimal glands). These concentrations are high enough to be effective without apparent local toxicity. At these concentrations, however, cyclosporine does not inhibit the systemic (thymic) ability of the body to respond, via T-cell proliferation/activation, to immune challenges. Only the early stages of T-cell activation and not the lymphocytic effector stages responsible for elimination of intruder cells are suppressed. Challenges to the ocular surface can still be met with T cells as well as B cells, phagocytes and other immune-responsive cells.^{6,11}

Supportive evidence for the immune integrity of the ocular surface is demonstrated by the lack of opportunistic ocular infections found in animals and humans. Thus, topical cyclosporine emulsion is thought to exert its therapeutic ophthalmic effect in part by its local immunomodulating activity rather than any systemic immunosuppressant effect.

Cellular Mechanism of Action

Historically, cyclosporine has been used systemically to prevent solid organ transplant rejection. Its mechanism of action at the cellular level has been well elucidated. As T cells become activated, a complex is formed within the cytoplasm composed of calcineurin (a calcium and calmodulin dependent serine/threonine phosphatase) and nuclear factor of activated T cells (NF-ATc).⁶ The formation of the complex results in a dephosphorylation of NF-ATc that is then able to translocate to the nucleus (NF-ATn) where it binds to a DNA-promoter region and initiates synthesis of several factors including pro-inflammatory cytokines.

Cyclosporine binds to its cytoplasmic receptor, cyclophilin, which is found in the cytoplasm of virtually all epithelial cells. Once this binding occurs, the cyclophilin binds to the calcineurin complex and prevents the dephosphorylation of NF-ATc. The nuclear translocation, and thus the promoter binding, is prevented and the T cell is unable to be activated. It is thought that the reason that it takes a few weeks for cyclosporine to be effective is that it does not deactivate previously activated T cells, but prevents new T-cell activation.

It has also been demonstrated that cyclosporine inhibits activation of NF- κ B, a nuclear factor involved in the regulation of immune and pro-inflammatory cytokine response genes, such as TNF, IL-1, IL-2, and IL-8.^{7,14} It prevents the synthesis and/or secretion of several TH1 pro-inflammatory cytokines such as IL-2, IL-6, IFN- γ ,^{15,20} IL-8,²² and TNF- α .¹⁷ It is also known to upregulate secretion of TH2-type anti-inflammatory cytokines, including IL-13.²³ IL-13 is thought to be one of the pivotal proteins involved in regulating TH2 (anti-inflammatory cytokine) production.

Dry-Eye Dog Model

The cellular mechanisms of chronic KCS and the effect of topical cyclosporine on the treatment of dry eye were evaluated using the dry-eye dog model. Fourteen dogs were divided into three groups. Group 1 (N = 5) received 0.2% cyclosporine emulsion, 1 drop twice daily (BID) in both eyes (OU) for 12 weeks. Group 2 (N = 5) received 0.05% cyclosporine emulsion, 1 drop BID OU for 12 weeks. Group 3 (N = 4) received vehicle, 1 drop BID OU for 12 weeks. After 12 weeks of treatment, no significant improvement was found in dogs on 0.05% cyclosporine and /or vehicle. Thus, following a minimum of one month wash out period, four of the five dogs in 0.05% cyclosporine group and two of the four dogs in vehicle group were switched to 0.2% cyclosporine group for further evaluation of the efficacy of 0.2% cyclosporine. Therefore, the total number of dry eye dogs on 0.2% by the end of the study was 11.

Biomicroscopic evaluation of dry eye dogs prior to cyclosporine treatment showed lusterless ocular surface, highly keratinized, translucent to opaque and vascularized. All dogs exhibited these severe ocular manifestations to some degree.

Evaluation of pre-treatment conjunctival biopsies demonstrated an increased level of lymphocytic infiltration suggesting local immunoreactivity. Tissue sections were stained using the TUNEL (Terminal deoxynucleotidyl Transferase Biotin-dUTP Nick End Labeling) method to detect apoptotic cells. TUNEL evaluation of biopsy specimens revealed positivity in lacrimal acinar cells. These terminally differentiated cells are typically stable. Infiltrating lymphocytes

that would normally be apoptotic were instead largely negative of apoptosis indicating activation and accumulation for these cells.

Post treatment (0.2% cyclosporine group) biomicroscopic evaluation at 12 weeks revealed restoration of ocular surface luster (Schirmer Tear Test, 10 out of 11 dry eye dogs treated with 0.2% cyclosporine), an improved demeanor (n=11) and a trend of improvement in the clinical conditions including elimination of corneal keratinization and improved corneal clarity. Two of the five dogs on 0.05% cyclosporine also demonstrated a similar improvement in the clinical aspects. No change was found in the vehicle group.

Histological evaluation of post-treatment biopsies demonstrated reduction of excessive lymphocytic conjunctival and accessory lacrimal gland infiltration (n=5 in 0.2% cyclosporine treated group). No significant improvement was found in the vehicle and 0.05% cyclosporine groups. Additionally, a decrease in the TUNEL positivity in lacrimal acinar epithelial cells was found in the 0.2% cyclosporine post-treatment specimens. The level of lymphocytic apoptosis decreased to a more normal range within the accessory lacrimal gland and conjunctiva.

In three dry eye dogs, an ELISA for TGF- β 1 was performed in tear samples before and after treatment (0.2% cyclosporine). The increased levels seen in the pre-treatment samples were decreased by more than one-half in two dogs. There was no change in the remaining dog. This initial TGF- β increase is viewed as an ocular surface response to inflammation/wounding. The decreased level of tear TGF- β 1 may reflect an improved or healed ocular surface.

Preclinical Pharmacokinetics:

Ocular Metabolism

Ocular tissues in albino rabbits do not metabolize cyclosporine. After a single 50 μ L eyedrop of 0.2% 3 H-cyclosporine emulsion to male and female albino rabbits, no metabolites of cyclosporine were detected in conjunctiva, cornea, sclera, aqueous humor, iris-ciliary body, choroid-retina, or lacrimal gland.

Ocular Absorption, Distribution, and Elimination

Topical ophthalmic administration of cyclosporine emulsions to albino rabbits and beagle dogs produced high concentrations in ocular surface tissues and relatively low concentrations in internal ocular tissues. Surface tissue concentrations after ophthalmic instillation of 0.2% cyclosporine emulsion were generally consistent between studies within a given species, and in cornea and sclera were higher in rabbits than beagle dogs after acute administration. Conjunctival concentrations were about equal in rabbits and dogs. Concentrations in internal ocular tissues were low and fairly consistent between studies within a given animal model, and in aqueous humor and iris-ciliary body were higher in albino rabbits than in beagle dogs.

Ocular tissue concentrations of cyclosporine in male beagle dogs given a single 35 μ L eyedrop of cyclosporine 0.2% ophthalmic emulsion were also relatively constant from 20 minutes through 3 hours, after which they declined slowly. After a single dose of 0.2% 3 H-cyclosporine emulsion, mean (C_{max}) in male beagle dogs was 1,494 ng-eq/g in conjunctiva, 311 ng-eq/g in

cornea, 94.6 ng-eq/g in sclera, 0.15 ng-eq/mL in aqueous humor, and 11.2 ng-eq/g in iris-ciliary body.

Ocular tissue concentrations after ophthalmic administration of cyclosporine emulsion to albino rabbits are dose-dependent at formulation concentrations of 0.05% to 0.4%. Cyclosporine emulsions with globule diameters larger than $\sim 50 \mu\text{m}$ have higher ocular bioavailability than emulsions with globule diameters smaller than $\sim 10 \mu\text{m}$, but are physically unstable. Ocular tissue concentrations of cyclosporine in albino rabbits given a 50 μL eyedrop of cyclosporine 0.05% or 0.1% ophthalmic emulsion to each eye BID for 9 1/2 days were relatively consistent through 12 hours after the last dose, and then declined slowly thereafter. After the last dose of 0.05% ^3H -cyclosporine emulsion, mean C_{max} in albino rabbits was 643 ng/g in conjunctiva, 1550 ng/g in cornea, 84.5 ng/g in sclera, 1.44 ng/mL in aqueous humor, and 74.7 ng/g in iris-ciliary body. After the last dose of 0.1% ^3H -cyclosporine emulsion, mean C_{max} in albino rabbits was 1970 ng/g in conjunctiva, 4810 ng/g in cornea, 262 ng/g in sclera, 7.19 ng/mL in aqueous humor, and 246 ng/g in iris-ciliary body.

Maximal concentrations obtained from rabbit and dog studies indicate that the great majority of drug contained in ocular tissues resides in the outer layers of the eye, and that little penetrates to the interior tissues. High concentrations in ocular surface tissues relative to internal ocular tissues, and long half-lives in ocular surface and internal tissues, suggest that these tissues act as a reservoir for cyclosporine, sequestering cyclosporine and releasing it slowly over prolonged periods. Half-lives in conjunctiva, cornea and sclera after multiple ophthalmic doses to albino rabbits and beagle dogs were longer than 24 hours. Because half-lives are long, peak-to-trough fluctuations in ocular concentrations are small within one dosing interval, thus ensuring continuous exposure to cyclosporine in the ocular surface tissues associated with dry eye.

Cyclosporine does not bind to melanin. Mean iris-ciliary body C_{max} after a single ophthalmic dose of 0.2% cyclosporine emulsion was 63.5 ng/g in albino rabbits and 11.2 ng-eq/g in beagle dogs. Although there were differences between the drop sizes used in rabbit (50 μL) and dog (35 μL) pharmacokinetic studies, tissue concentrations between these 2 species were comparable and in fact tended to be lower in the pigmented species. During twice-daily (BID) dosing to dogs for 1 week, mean C_{max} in iris-ciliary body and choroid-retina increased only 219% and 77%, respectively, which further indicates an absence of significant melanin binding in these animals. Because of the lack of substantial accumulation in dog iris-ciliary body and choroid-retina, melanin binding is unlikely in pigmented animals or humans.

Clinical Pharmacokinetics:

Blood concentrations of cyclosporin A following ophthalmic administration of cyclosporine ophthalmic emulsions were measured in human blood using a sensitive liquid chromatography/mass spectrometry-mass spectrometry (LC/MS-MS) assay specific for cyclosporin A. The lower limit of quantitation was 0.1 ng/mL.

Blood samples collected during Phase 2 and Phase 3 studies of cyclosporine ophthalmic emulsions have shown that blood concentrations are barely detectable and are several orders of magnitude below those produced by approved systemic cyclosporine treatments for rheumatoid arthritis and psoriasis.

Blood cyclosporin A concentrations were determined in a safety, tolerability, and efficacy study of cyclosporine in 162 human patients with moderate to severe dry eye. Male and female patients instilled one ~28.5 µL eyedrop of vehicle emulsion or 0.05, 0.1, 0.2 or 0.4% cyclosporine emulsion twice-daily to each eye for 12 weeks in a double-masked, randomized, parallel-group study.

In each treatment group, blood samples were collected from 28-33 patients at morning troughs (C_{\min}) after 1, 4 and 12 weeks of dosing. Blood samples were also collected from approximately 18 patients at 1, 2 and 4 hours after the last dose of the 12-week treatment period. Blood cyclosporin A concentrations were measured using a sensitive and selective LC/MS-MS assay with a quantitation limit of 0.1 ng/mL. C_{\max} was defined as the highest concentration observed at 1, 2, or 4 hours after dosing on week 12.

Table 5: Trough and maximum concentrations of cyclosporin A in human blood after ophthalmic administration of 0.05, 0.1, 0.2 or 0.4% cyclosporine emulsion twice-daily to each eye for 12 weeks.

Cyclosporine emulsion	C_{\min} (ng/mL) ^a	C_{\max} (ng/mL) ^b
0.05%	<0.1 ^c	<0.1 ^c
0.1%	<0.1 to 0.102	<0.1 ^c
0.2%	<0.1 to 0.108	<0.1 to 0.144
0.4%	<0.1 to 0.157	<0.1 to 0.158

^a trough concentrations for 28-33 patients per treatment group over 12 weeks of dosing

^b N=3-5 patients per treatment group after 12 weeks of dosing

^c below the limit of quantitation

Week 12 blood C_{\min} and C_{\max} pharmacokinetic parameters are summarized in Table 5. Cyclosporin A was not detectable in the blood of vehicle-treated patients or during prestudy qualification. Ophthalmic administration of cyclosporine emulsions up to 0.4% produced blood cyclosporin A concentrations of less than 0.2 ng/mL following twice-daily topical dosing over a 12-week period. Trough blood concentrations in most of the 120 patients were less than 0.1 ng/mL. Only five patients showed quantifiable trough concentrations, and these were all less than 0.160 ng/mL. Comparison of trough blood concentrations for weeks 1, 4, and 12 suggests no substantial accumulation during the 12 week dosing period. Blood C_{\max} ranged from less than 0.1 ng/mL to 0.158 ng/mL. Overall, the results of this study indicate that ocular instillation of 0.05-0.4% cyclosporine emulsion produced very low systemic exposure to cyclosporin A.

Blood cyclosporin A concentrations were determined in a safety and efficacy study of cyclosporine ophthalmic emulsions in ~300 patients with moderate to severe dry eye. Male and female patients instilled one eyedrop of vehicle emulsion or 0.05 or 0.1% cyclosporine emulsion twice-daily to each eye for six months in a double-masked, randomized, parallel-group study. After six months of treatment, patients in the 0.05% cyclosporine emulsion treatment group were switched to 0.1% cyclosporine emulsion, after which they continued the BID treatment regimen through 12 months.

Blood samples were collected immediately before the morning dose from 113 patients at 1 month and 94 patients at 6 months, after which the trough blood cyclosporin A concentrations in

these samples were measured using a highly sensitive and selective LC/MS-MS assay with a quantitation limit of 0.1 ng/mL.

Trough cyclosporin A concentrations were quantifiable in only six samples from six different patients: three at month 1 and three at month 6. One concentration was 0.299 ng/mL and the other five were ≤ 0.144 ng/mL. Of the three patients whose cyclosporin A concentration was quantifiable at three months, two had a concentration that was below the limit of quantification at 6 months, and one did not provide a 6 month sample. All three patients whose cyclosporin A concentration was quantifiable at 6 months had a 3 month concentration that was below the limit of quantification. All trough concentrations other than these six were below the quantitation limit of 0.1 ng/mL.

Blood concentrations of cyclosporin A were determined over the course of one dosing interval in a Phase 3 safety and efficacy study of cyclosporine ophthalmic emulsions in patients with moderate to severe dry eye. The objective was to quantify the C_{\max} and AUC_{0-12} of cyclosporin A in blood during topical ophthalmic treatment with 0.05 and 0.1% cyclosporine emulsions.

Male and female patients instilled one eyedrop of vehicle emulsion or 0.05 or 0.1% cyclosporine emulsion twice-daily to each eye for 6 months in a double-masked, randomized, parallel-group study. At month 6, patients in the vehicle emulsion treatment group began treatment with 0.1% cyclosporine emulsion, while patients already taking 0.05 or 0.1% cyclosporine emulsion continued treatment without change. Blood samples were collected during months 9 to 12 from 26 patients at 1, 2, 3, 4, 6, 8, 10, and 12 hours after the morning dose. Blood cyclosporin A concentrations in these samples were measured using a sensitive and selective LC/MS-MS assay with a quantitation limit of 0.1 ng/mL.

Of 208 postdose blood samples from 26 patients, only 3 samples from 3 different patients contained quantifiable cyclosporine. They were: 0.102 ng/mL at 1 hr, 0.104 ng/mL at 2 hr, and 0.105 at 3 hr. One of these three patients had received 0.1% cyclosporine emulsion for 9 to 12 months, while the other two patients received vehicle emulsion for the first 6 months of the study and then 0.1% cyclosporine emulsion for 3 to 6 months prior to blood sampling. Concentrations in the other 205 samples were below the quantitation limit of 0.1 ng/mL.

TOXICOLOGY

Three preclinical safety studies evaluated the local and systemic effects of repeated dose cyclosporine ophthalmic emulsion. The most sensitive species for ocular reactions, the New Zealand White (NZW) rabbit was used in two studies. A species with pigmented eyes, the dog, was used in one additional study. Details of the study conduct and results may be referred to in Tables 7 through 9.

The animal safety studies used an exaggerated design with cyclosporine emulsion in concentrations up to 0.4% administered as one drop in one eye up to six times daily. This is 12 times the recommended dose, cyclosporine emulsion administered as one drop in each eye twice daily. The dogs and the rabbits (which are approximately seven to 20 times smaller in body

weight, respectively, when compared to a 60 kg human) were exposed systemically with high ocular dosages in order to evaluate the effect of high systemic exposure and the safety of topically administered cyclosporine.

Ocular Safety

In the subchronic toxicity study, cyclosporine ophthalmic emulsions (0.05%, 0.2% and 0.4%) were well tolerated locally when administered to rabbits for 3 months. The only treatment-related effects were a transient slight ocular discomfort and transient slight conjunctival hyperemia. There were no compound-related microscopic changes in the eye.

Similarly, in the chronic toxicity studies, cyclosporine ophthalmic emulsions were well tolerated locally when administered to rabbits for 6 months and dogs for 52 weeks. The only treatment-related effects were a transient slight ocular discomfort and transient slight conjunctival hyperemia in the rabbit study. There were no compound-related microscopic changes in the eye.

Systemic Safety

The data from the 3-month and 6-month studies in rabbits and the 1-year study in dogs showed that ophthalmic administration of cyclosporine emulsion in concentrations up to 0.4% administered as 1 drop in 1 eye up to 6 times daily produced no systemic toxicity. There were no changes in the kidney, which is the target organ of toxicity of systemic cyclosporine, nor were there liver changes. No changes were observed in any organ or tissue including the organs related to the immune system (spleen, thymus, lymph nodes). No changes in the peripheral blood (white blood cells [WBC] and lymphocytes) were noted which suggests no impact on the systemic immune system.

In organ transplant patients receiving high doses of cyclosporine systemically, rare cases of visual disturbances due to morphological cerebral changes have been observed.^{10,13,16} However, no neurotoxicity was observed following topical cyclosporine in these animal safety studies. All of the ocular tissues were unaffected.

Blood concentrations of cyclosporin A were consistently low, even with the exaggerated dosing regimens used in these studies. The majority of individual blood concentrations were less than 1.0 ng/mL.

Table 6: A Three Month Ocular and Systemic Toxicity Study with a One-Month Recovery Period in New Zealand White Rabbits

Species and strain	Animals/group	Emulsions	Dose & Route	Dosing duration	Parameters measured	Results
New Zealand white rabbit	10 males and 10 females per group 8/sex/group sacrificed after 3 months 2/sex/group sacrificed after 1-month recovery	Vehicle of 0.4% cyclosporine, 3x/day at ~3 hr intervals 0.05% cyclosporine, 3x/day at ~3 hr intervals 0.2% cyclosporine, 3x/day at ~3 hr intervals 0.4% cyclosporine, 3x/day at ~3 hr intervals	~40 µL eyedrop to 1 eye only	3 months followed by a 1-month recovery period	Clinical observations, gross ocular observations, ophthalmoscopic and slit lamp examinations, body weight, hematology, serum chemistry, blood drug concentration, organ weight, and macroscopic and microscopic examinations	Transient, slight ocular discomfort lasting, in most cases, no more than 30 seconds was observed in all animals, including the vehicle group animals. Transient, slight conjunctival hyperemia was observed with a dose-related incidence throughout the treatment period. There were no compound-related effects on clinical signs, slit lamp biomicroscopy, ophthalmoscopy, body weight, hematology, blood chemistry, organ weight, and macroscopic and microscopic examinations. Blood cyclosporin A concentrations in animals treated with 0.05% cyclosporine emulsion were generally below the quantitation limit of 0.2ng/mL in rabbit blood. In both sexes combined, mean C _{max} were 1.48 and 0.721 ng/mL after 3 months treatment with 0.2% and 0.4% cyclosporine emulsion, respectively. The highest individual blood C _{max} of 2.79 and 8.58 ng/mL were seen in one 0.4%-treated rabbit and one 0.2%-treated rabbit, respectively. Except for these 2 concentrations, the majority of individual blood concentrations in 0.2%- and 0.4%-treated animals were below 1.0 ng/mL. The mean AUC _{0-tlast} values after dosing with 0.2% and 0.4% cyclosporine ophthalmic emulsions in rabbits were 4.52 and 4.28 ng·hr/mL, respectively.

Abbreviations: C_{max} = maximum concentration; AUC_{0-tlast} = area under the curve of tissue concentration versus time, from the time of dose instillation through the last sampling time or the last sampling time at which cyclosporin A was quantifiable (tlast).

Table 7: Six Month Ocular and Systemic Toxicity Study with a 2-Month Recovery Period in New Zealand White Rabbits

Species and strain	Animals/group	Emulsions	Dose & route	Dosing duration	Parameters measured	Results
New Zealand white rabbit	15 males and 15 females per group 10/sex/group sacrificed after 6 months 5/sex/group sacrificed after 2-month recovery additional 3/sex satellite animals assigned to 0.4% dose group (6x/day), used for blood drug concentration on day 8	Vehicle of 0.2% cyclosporine, 3x/day at ~3 hr intervals Vehicle of 0.4% cyclosporine, 6x/day at ~2 hr intervals 0.05% cyclosporine, 3x/day at ~3 hr intervals 0.2% cyclosporine, 3x/day at ~3 hr intervals 0.4% cyclosporine, 3x/day at ~3 hr intervals 0.4% cyclosporine, 6x/day at ~2 hr intervals	~40 µL eyedrop to 1 eye only	6 months followed by a 2-month recovery period.	Clinical observations, gross ocular observations, ophthalmoscopic and slit lamp examinations, body weight, hematology, serum chemistry, blood drug concentration, organ weight, and macroscopic and microscopic examinations	<p>Transient, slight ocular discomfort lasting, in most cases, no more than 30 seconds was observed in all animals, including the vehicle group animals. Transient, slight conjunctival hyperemia was observed with higher incidence in cyclosporine-treated animals when compared to controls. During the 1st week of the study, sporadic instances of slight to mild iritis and slight aqueous flare were observed in cyclosporine-treated animals, however these findings did not last more than 2 days and were not dose-related. There were no gross ocular findings during the recovery period. The grossly observed hyperemia was confirmed at the slit lamp examinations at 1 month, 3 months, and at the end of the treatment period in which slight to moderate conjunctival congestion and slight discharge were observed in all treatment groups except the 0.2% vehicle control. There were no compound-related effects on clinical signs, ophthalmoscopy, body weight, hematology, blood chemistry, organ weight, and macroscopic and microscopic examinations.</p> <p>Blood cyclosporin A concentrations were low, and increased less than proportionally to dose. In both sexes combined, mean C_{max} in 0.05%, 0.2%, and 0.4% 3 times daily, and 0.4% 6 times daily cyclosporine emulsion groups after 6 months treatment were 0.328, 0.997, 0.570, and 1.36 ng/mL, respectively. The highest individual peak blood cyclosporin A concentration of 3.75 ng/mL was seen in one rabbit dosed with 0.2% cyclosporine emulsion. The majority of the individual blood C_{max} values were below 1.0 ng/mL. The mean $AUC_{0-tlast}$ ($6.5 \leq t_{last} \leq 24$ hr) at these doses were 3.48, 9.25, 6.85, and 16.7 ng·hr/mL, respectively.</p>

Abbreviations: C_{max} = maximum concentration; $AUC_{0-tlast}$ = area under the curve of tissue concentration versus time, from the time of dose instillation through the last sampling time or the last sampling time at which cyclosporin A was quantifiable (tlast).

Table 8: 52-Week Ocular and Systemic Study of Cyclosporine in Dogs with an 8-Week Recovery Period

Species and strain	Animals/group	Emulsions	Dose & Route	Dosing Duration	Parameters Measured	Results
Dog, beagle.	6 males and 6 females per group 4/sex/group sacrificed after 52 weeks 2/sex/group sacrificed after 8-week recovery	Vehicle of 0.4% cyclosporine, 6x/day at ~2 hr intervals 0.1% cyclosporine, 3x/day at ~3 hr intervals 0.2% cyclosporine, 3x/day at ~3 hr intervals 0.4% cyclosporine, 6x/day at ~2 hr intervals	~40 µL eyedrop to 1 eye only.	52 weeks followed by an 8-week recovery period	Clinical observations, gross ocular observations, ophthalmoscopic and slit lamp examinations, body weight, food consumption, hematology, blood chemistry, urine analysis, blood pressure, electrocardiography, organ weight, and macroscopic and microscopic examinations	No evidence of discomfort was associated with application of the eye drops in any of the dogs. Reddened conjunctiva was noted sporadically in individual animals within both the vehicle control and cyclosporine-treated animals, but there was no suggestion of a dose response. There was a tendency toward an increased tears of the treated eye observed in the 0.4% cyclosporine-treated animals. No changes were observed upon ophthalmoscopic and slit lamp examinations. There were no compound-related effects on clinical signs, body weight, food consumption, hematology, blood chemistry, urine analysis, blood pressure, electrocardiography, organ weight, and macroscopic and microscopic examinations. The maximum blood cyclosporin A concentration following instillation of 0.1% 3 times daily, 0.2% 3 times daily, and 0.4% 6 times daily was below 1.2 ng/mL. Mean blood C_{max} following instillation of 0.1% 3 times daily, 0.2% 3 times daily, and 0.4% cyclosporine emulsion 6 times daily for 49 weeks were 0.299, 0.459, and 0.675 ng/mL, respectively. The mean $AUC_{0-t_{last}}$ ($9 \leq t_{last} \leq 24$ hr) after 0.1% 3 times daily, 0.2% 3 times daily, and 0.4% cyclosporine emulsion 6 times daily were 2.35, 3.39, and 9.55 ng·hr/mL, respectively. The mean C_{max} and $AUC_{0-t_{last}}$ indicated that blood concentrations were dose-dependent. Comparisons of minimum concentrations (C_{min}), C_{max} and $AUC_{0-t_{last}}$ during weeks 1 and 49 for each treatment group indicated no marked systemic drug accumulation.

Abbreviations: C_{max} = maximum concentration; $AUC_{0-t_{last}}$ = area under the curve of tissue concentration versus time, from the time of dose instillation through the last sampling time or the last sampling time at which cyclosporin A was quantifiable (t_{last}).

Carcinogenesis and Mutagenesis: Systemic carcinogenicity studies were carried out in male and female mice and rats. In the 78-week oral (diet) mouse study, at doses of 1, 4, and 16 mg/kg/day, evidence of a statistically significant trend was found for lymphocytic lymphomas in females, and the incidence of hepatocellular carcinomas in mid-dose males significantly exceeded the control value.

In the 24-month oral (diet) rat study, conducted at 0.5, 2, and 8 mg/kg/day, pancreatic islet cell adenomas significantly exceeded the control rate in the low dose level. The hepatocellular carcinomas and pancreatic islet cell adenomas were not dose related. The low doses in mice and rats are approximately 1000 and 500 times greater, respectively, than the daily human dose of one drop (28 µL) of cyclosporine ophthalmic emulsion 0.05% twice daily into each eye of a 60 kg person (0.001 mg/kg), assuming that the entire dose is absorbed.

Cyclosporine has not been found mutagenic/genotoxic in the Ames Test, the V79-HGPRT Test, the micronucleus test in mice and Chinese hamsters, the chromosome-aberration tests in Chinese hamster bone-marrow, the mouse dominant lethal assay, and the DNA-repair test in sperm from treated mice. A study analyzing sister chromatid exchange (SCE) induction by cyclosporine using human lymphocytes *in vitro* gave indication of a positive effect (i.e., induction of SCE).

Reproductive Toxicology: No evidence of teratogenicity was observed in rats or rabbits receiving oral doses of cyclosporine of up to 17 mg/kg/day or 30 mg/kg/day, respectively, during organogenesis. These doses in rats and rabbits are approximately 17,000 and 30,000 times greater, respectively, than the daily human dose of one drop (28 µL) of cyclosporine ophthalmic emulsion 0.05% twice daily into each eye of a 60 kg person (0.001 mg/kg/day), assuming that the entire dose is absorbed.

Adverse effects were seen in reproduction studies in rats only at dose levels toxic to dams. At toxic doses (rats at 30 mg/kg/day and rabbits at 100 mg/kg/day), cyclosporine oral solution, USP, was embryo- and fetotoxic as indicated by increased pre- and postnatal mortality and reduced fetal weight, together with related skeletal retardations. These doses are 30,000 times and 100,000 times greater, respectively than the daily human dose of one-drop (28 µL) of cyclosporine ophthalmic emulsion 0.05% twice daily into each eye of a 60 kg person (0.001 mg/kg/day), assuming that the entire dose is absorbed.

Offspring of rats receiving a 45 mg/kg/day oral dose of cyclosporine from Day 15 of pregnancy until Day 21 post partum – a maternally toxic level- exhibited an increase in postnatal mortality; this dose is 45,000 times greater than the daily human topical dose, 0.001 mg/kg/day, assuming that the entire dose is absorbed. No adverse events were observed at oral doses of up to 15 mg/kg/day (15,000 times greater than the daily human dose).

REFERENCES

1. Anonymous. 2007 Report of the International Dry Eye WorkShop (DEWS). *The Ocular Surface*, April 2007; 5(2):65-204.
2. Barber LD, Pflugfelder SC, Tauber J, Foulks GN. Phase III safety evaluation of cyclosporine 0.1% ophthalmic emulsion administered twice daily to dry eye disease patients for up to 3 years. *Ophthalmology* 2005;112(10):1790-1794.
3. Baudouin C, Brignole F, Pisella P, De Saint Jean M, Goguel A. Flow cytometric analysis of the inflammatory marker HLA DR in dry eye syndrome: Results from 12 months of randomized treatment with topical cyclosporin A. In: Sullivan David A, ed. *Advances in Experimental Medicine and Biology*. Volume 506. Lacrimal Gland, Tear Film, and Dry eye Syndrome Basic Science and Clinical Relevance. Part B ed. 233 Spring Street, New York, New York 10013: Kluwer Academic/Plenum Publishers, New York 2002;506:761-769.
4. Behrens A, Doyle JJ, Stern L, et al. Dysfunctional Tear Syndrome: a Delphi approach to treatment recommendations. *Cornea* 2006;25(8):900-907.
5. Belin MW, Bouchard CS, Phillips TM. Update on topical cyclosporin A: background, immunology, and pharmacology. *Cornea* 1990; 9:184-195.
6. Borel JF, Baumann G, Chapman I, Donatsch P, et al. *In Vivo* pharmacological effects of ciclosporin and some analogues. *Adv Pharmacol* 1996:115-246.
7. Boss V, Wang X, Koppelman LF, et al. Histamine induces nuclear factor of activated T cell-mediated transcription and cyclosporin A-sensitive interleukin-8 mRNA expression in human umbilical vein endothelial cells. *Mol Pharmacol* 1998; 54:264-72.
8. Donnenfeld E, Pflugfelder SC Topical ophthalmic cyclosporine: Pharmacology and clinical uses. *Surv Ophthalmol* 2009;54(3):321-338.
9. Gao J, Schwalb TA, Addeo JV, et al. The role of apoptosis in the pathogenesis of canine Keratoconjunctivitis Sicca: The effect of topical cyclosporin A therapy. *Cornea* 1998;17(6):654-63
10. Ghalie R, Fitzsimmons WE, Bennett D, et al. Cortical blindness: a rare complication of cyclosporine therapy. *Bone Marrow Transplant* 1990;6:147-149.
11. Kahan BD. Drug Therapy. Cyclosporine. *New Eng J Med* 1989;321:1725-38.
12. Kunert KS Tisdale AS, Gipson IK. Goblet cell numbers and epithelial proliferation in the conjunctiva of patients with dry eye syndrome treated with cyclosporine. *Arch Ophthalmol* 2002;120(3):330-337.
13. Memon M, deMagalhaes-Silverman M, Bloom EG, et al. Reversible cyclosporine-induced cortical blindness in allogeneic bone marrow transplant recipients. *Bone Marrow Transplant* 1995;15:283-286.
14. Meyer S, Kohler G, Joly A, et al. Cyclosporine A is an uncompetitive inhibitor of proteasome activity and prevents NF- κ B activation. *FEBS Letters* 1997;41(3):354-8.
15. Mitruka SN, Pham SM, Zeevi A, Li S, Cai J, Burckart GJ, Yousem SA, Keenan RJ, Griffith BP. Aerosol ciclosporin prevents acute allograft rejection in experimental lung transplantation. *J Thorac Cardiovasc Surg* 1998;115(1):28-36.
16. Nussbaum ES, Maxwell RE, Bitterman PB, et al. Cyclosporine A toxicity presenting with acute cerebellar edema and brainstem compression. *J Neurosurg* 1995;82:1068-1070.
17. Pette M, Pette DF, Muraro PA, Martin R, McFarland HF. *In vitro* modulation of human, auto reactive MBP-specific CD4⁺ T-cell clones by ciclosporin A. *J Neuroimmunol* 1997;76(1-2):91-9.

18. Pflugfelder SC, Solomon A, Stern ME. The diagnosis and management of dry eye; A twenty-five-year review. *Cornea* 2000; 19(5):644-649.
19. Product Monograph, NEORAL® / SANDIMMUNE® 2008.
20. Schliephake H, Redecker K, Schmelzeisen R, Maschek H. Cytokines and cytokine receptors in mouth mucosa of immune suppressed patients. *Mund Kiefer Gesichtschir* 1997;192:111-4 (article in German, abstract in English).
21. Stern ME, Beuerman RW, Fox RI, et al. The pathology of dry eye: The interaction between the ocular surface and the lacrimal glands. *Cornea* 1998;17(6):584-9.
22. Svecova D, Kawashima T, Ohkawara A. Production of IL-8 by the THP-1 monocyte cell line is regulated differently by ciclosporin and retinoic acid. *Bratisl Lek Listy* 1998;99(1)48-53 (article in Slovak, abstract in English).
23. Van der Pouw Kraan TC, Boeije LC, Troon JT, Rutschmann SK, Wijdenes J, Aarden LA. Human IL-13 production is negatively influenced by CD3 engagement. Enhancement of IL-13 production by ciclosporin A. *J Immunol* 1996;156(5):1818-23.

PART III: CONSUMER INFORMATION

Pr RESTASIS®

(cyclosporine)

Ophthalmic Emulsion, 0.05% w/v

This leaflet is part III of a three-part “Product Monograph”, published when RESTASIS® was approved for sale in Canada, and is designed specifically for Consumers. This leaflet is a summary and will not tell you everything about RESTASIS®. Contact your doctor or pharmacist if you have any questions about the drug.

ABOUT THIS MEDICATION

What the medication is used for:

RESTASIS® is used to treat certain patients whose eyes are not producing enough tears to keep the eye moist and comfortable.

What it does:

RESTASIS® acts as a topical immunomodulator with anti-inflammatory effects.

When it should not be used:

RESTASIS® should not be used if

- you have an eye infection
- you are hypersensitive to cyclosporine or any of the other ingredients in the formulation (see **What the non-medicinal ingredients are**).

What the medicinal ingredient is:

The active ingredient is cyclosporine.

What the non-medicinal ingredients are:

The other ingredients in the formulation are Carbomer Copolymer Type A, castor oil, glycerin, polysorbate 80, purified water and sodium hydroxide.

What dosage forms it comes in:

RESTASIS® is available as a sterile ophthalmic emulsion, in a 0.4 mL single use plastic vial.

WARNINGS AND PRECAUTIONS

BEFORE you use RESTASIS®, talk to your doctor or pharmacist if:

You have a history of *herpes keratitis*. RESTASIS® has not been tested for use in people with this condition

Your dry eyes are the result of Vitamin A deficiency or scarring. RESTASIS® has not been studied in people with these causes of dry eyes.

You drive or operate machinery. RESTASIS® may cause your vision to blur right after you put the drops in. Wait a few minutes

until your vision clears before you try to drive or operate a machine.

You are breast feeding a baby. It is not known whether or not cyclosporine is passed into breast milk.

You are pregnant or planning to become pregnant. While there are no known adverse effects on human pregnancy, there is very little information available, and you should decide with your doctor how best to proceed.

Do not administer RESTASIS® while you wear contact lenses. If you must wear contact lenses, remove the lenses before applying RESTASIS®. Wait for 15 minutes before you put your contact lenses back in.

You should also avoid touching the tip of the vial to the eye or any surface as this may contaminate the emulsion, or touching the eye may cause injury.

INTERACTIONS WITH THIS MEDICATION

No drug interaction studies have been performed with RESTASIS®. Concomitant use with other eye products should be discussed with your doctor beforehand.

PROPER USE OF THIS MEDICATION

Usual Adult Dose:

The usual adult dose of RESTASIS® is one drop into each affected eye. This dose should be applied twice a day – about 12 hours apart.

Before using, gently shake the vial by tipping it up and down a few times until the emulsion is white and appears the same throughout the vial.

Each individual, single-use vial should be used immediately after opening for administration to one or both eyes, and the remaining contents discarded immediately after administration.

RESTASIS® may be used together with artificial tears. Wait 15 minutes between using RESTASIS® and the artificial tear product.

Overdose:

If you have taken too much RESTASIS®, particularly accidental oral ingestion, contact your healthcare practitioner (e.g. doctor), hospital emergency department or regional Poison Control Centre, even if there are no symptoms.

Missed dose:

If you miss a dose, take it as soon as possible. However, if it is almost time for the next dose, skip the missed dose and go back to the regular dosing schedule. Do not double your dose.

SIDE EFFECTS AND WHAT TO DO ABOUT THEM

Ocular burning is a very common ($\geq 1/10$) adverse event with RESTASIS®. Other common events ($\geq 1/100$) are eye irritation, headache, foreign body sensation in eye, ocular / conjunctival hyperaemia (redness), eye pain, eye stinging, eye discharge, photophobia, eye pruritus, blurred vision, dry eye. These events usually get better on their own, as your eye becomes used to treatment with RESTASIS®.

There is the potential to experience an allergic reaction to RESTASIS®. Reactions of face swelling, tongue swelling, throat swelling, shortness of breath and itchy skin rash have been reported with the use of RESTASIS®. If an allergic reaction occurs, discontinue the drug and contact your physician.

This is not a complete list of side effects. For any unexpected effects while taking RESTASIS®, contact your doctor or pharmacist.

HOW TO STORE IT

RESTASIS® should be stored at 15-25°C. Keep unused vials within the resealable tray.

Keep out of reach of children.

REPORTING SUSPECTED SIDE EFFECTS

You can report any suspected adverse reactions associated with the use of health products to the Canada Vigilance Program by one of the following 3 ways:

- Report online at www.healthcanada.gc.ca/medeffect
- Call toll-free at 1-866-234-2345
- Complete a Canada Vigilance Reporting Form and:
 - Fax toll-free to 1-866-678-6789, or
 - Mail to: Canada Vigilance Program
Health Canada
Postal Locator 0701D
Ottawa, Ontario
K1A 0K9

Postage paid labels, Canada Vigilance Reporting Form and the adverse reaction reporting guidelines are available on the MedEffect™ Canada Web site at www.healthcanada.gc.ca/medeffect.

NOTE: Should you require information related to the management of side effects, contact your health professional. The Canada Vigilance Program does not provide medical advice.

MORE INFORMATION

This document plus the full product monograph, prepared for health professions, can be obtained by contacting the sponsor, Allergan Inc. at 1-877-255-3746.

This leaflet was prepared by Allergan Inc.

Last revised: October 03, 2012

HIGHLIGHTS OF PRESCRIBING INFORMATION

These highlights do not include all the information needed to use RESTASIS® 0.05% safely and effectively. See full prescribing information for RESTASIS®.

**RESTASIS® (cyclosporine ophthalmic emulsion) 0.05%
For topical ophthalmic use
Initial U.S. Approval: 1983**

INDICATIONS AND USAGE

RESTASIS® is a calcineurin inhibitor immunosuppressant indicated to increase tear production in patients whose tear production is presumed to be suppressed due to ocular inflammation associated with keratoconjunctivitis sicca. Increased tear production was not seen in patients currently taking topical anti-inflammatory drugs or using punctal plugs. (1)

DOSAGE AND ADMINISTRATION

Instill one drop of RESTASIS® ophthalmic emulsion twice a day in each eye approximately 12 hours apart. (2)

DOSAGE FORMS AND STRENGTHS

Cyclosporine ophthalmic emulsion 0.5 mg/mL (3)

CONTRAINDICATIONS

- Hypersensitivity (4)

WARNINGS AND PRECAUTIONS

- To avoid the potential for eye injury and contamination, be careful not to touch the vial tip to your eye or other surfaces. (5.1)

ADVERSE REACTIONS

The most common adverse reaction following the use of RESTASIS® was ocular burning (17%). (6.1)

To report SUSPECTED ADVERSE REACTIONS, contact Allergan at 1-800-433-8871 or FDA at 1-800-FDA-1088 or www.fda.gov/medwatch.

See 17 for PATIENT COUNSELING INFORMATION.

Revised: XX/2017

FULL PRESCRIBING INFORMATION: CONTENTS***1 INDICATIONS AND USAGE****2 DOSAGE AND ADMINISTRATION****3 DOSAGE FORMS AND STRENGTHS****4 CONTRAINDICATIONS****5 WARNINGS AND PRECAUTIONS**

- 5.1 Potential for Eye Injury and Contamination
- 5.2 Use with Contact Lenses

6 ADVERSE REACTIONS

- 6.1 Clinical Trials Experience
- 6.2 Post-marketing Experience

8 USE IN SPECIFIC POPULATIONS

- 8.1 Pregnancy
- 8.2 Lactation
- 8.4 Pediatric Use
- 8.5 Geriatric Use

11 DESCRIPTION**12 CLINICAL PHARMACOLOGY**

- 12.1 Mechanism of Action
- 12.3 Pharmacokinetics

13 NONCLINICAL TOXICOLOGY

- 13.1 Carcinogenesis, Mutagenesis, Impairment of Fertility

14 CLINICAL STUDIES**16 HOW SUPPLIED/STORAGE AND HANDLING****17 PATIENT COUNSELING INFORMATION**

* Sections or subsections omitted from the full prescribing information are not listed.

FULL PRESCRIBING INFORMATION

1 INDICATIONS AND USAGE

RESTASIS[®] ophthalmic emulsion is indicated to increase tear production in patients whose tear production is presumed to be suppressed due to ocular inflammation associated with keratoconjunctivitis sicca. Increased tear production was not seen in patients currently taking topical anti-inflammatory drugs or using punctal plugs.

2 DOSAGE AND ADMINISTRATION

Invert the unit dose vial a few times to obtain a uniform, white, opaque emulsion before using. Instill one drop of **RESTASIS**[®] ophthalmic emulsion twice a day in each eye approximately 12 hours apart. **RESTASIS**[®] can be used concomitantly with lubricant eye drops, allowing a 15-minute interval between products. Discard vial immediately after use.

3 DOSAGE FORMS AND STRENGTHS

Ophthalmic emulsion containing cyclosporine 0.5 mg/mL

4 CONTRAINDICATIONS

RESTASIS[®] is contraindicated in patients with known or suspected hypersensitivity to any of the ingredients in the formulation.

5 WARNINGS AND PRECAUTIONS

5.1 Potential for Eye Injury and Contamination

Be careful not to touch the vial tip to your eye or other surfaces to avoid potential for eye injury and contamination.

5.2 Use with Contact Lenses

RESTASIS[®] should not be administered while wearing contact lenses. Patients with decreased tear production typically should not wear contact lenses. If contact lenses are worn, they should be removed prior to the administration of the emulsion. Lenses may be reinserted 15 minutes following administration of **RESTASIS**[®] ophthalmic emulsion.

6 ADVERSE REACTIONS

The following serious adverse reactions are described elsewhere in the labeling:

- Potential for Eye Injury and Contamination [*see Warnings and Precautions (5.1)*]

6.1 Clinical Trials Experience

Because clinical trials are conducted under widely varying conditions, adverse reaction rates observed in the clinical trials of a drug cannot be directly compared to rates in the clinical trials of another drug and may not reflect the rates observed in practice.

In clinical trials, the most common adverse reaction following the use of **RESTASIS**[®] was ocular burning (17%).

Other reactions reported in 1% to 5% of patients included conjunctival hyperemia, discharge, epiphora, eye pain, foreign body sensation, pruritus, stinging, and visual disturbance (most often blurring).

6.2 Post-marketing Experience

The following adverse reactions have been identified during post approval use of **RESTASIS**[®]. Because these reactions are reported voluntarily from a population of uncertain size, it is not always possible to reliably estimate their frequency or establish a causal relationship to drug exposure.

Reported reactions have included: hypersensitivity (including eye swelling, urticaria, rare cases of severe angioedema, face swelling, tongue swelling, pharyngeal edema, and dyspnea); and superficial injury of the eye (from the vial tip touching the eye during administration).

8 USE IN SPECIFIC POPULATIONS

8.1 Pregnancy

Risk Summary

Clinical administration of cyclosporine ophthalmic emulsion 0.05% is not detected systemically following topical ocular administration [*see Clinical Pharmacology (12.3)*], and maternal use is not expected to result in fetal exposure to the drug. Oral administration of cyclosporine to pregnant rats or rabbits did not produce teratogenicity at clinically relevant doses [*see Data*].

Data

Animal Data

At maternally toxic doses (30 mg/kg/day in rats and 100 mg/kg/day in rabbits), cyclosporine oral solution (USP) was teratogenic as indicated by increased pre- and postnatal mortality, reduced fetal weight and skeletal retardations. These doses (normalized to body surface area) are 5,000 and 32,000 times greater, respectively, than the daily recommended human dose of one drop (approximately 28 mcL) of cyclosporine ophthalmic emulsion 0.05% twice daily into each eye of a 60 kg person (0.001 mg/kg/day), assuming that the entire dose is absorbed. No evidence of embryofetal toxicity was observed in rats or rabbits receiving cyclosporine during organogenesis at oral doses up to 17 mg/kg/day or 30 mg/kg/day, respectively. These doses in rats and rabbits are approximately 3,000 and 10,000 times greater, respectively, than the daily recommended human dose. An oral dose of 45 mg/kg/day cyclosporine administered to rats from Day 15 of pregnancy until Day 21 postpartum produced maternal toxicity and an increase in postnatal mortality in offspring. This dose is 7,000 times greater than the daily recommended human dose. No adverse effects in dams or offspring were observed at oral doses up to 15 mg/kg/day (2,000 times greater than the daily recommended human dose).

8.2 Lactation

Risk Summary

Cyclosporine is known to appear in human milk following systemic administration, but its presence in human milk following topical treatment has not been investigated. Although blood concentrations are undetectable following topical administration of **RESTASIS**[®] ophthalmic emulsion [*see Clinical Pharmacology (12.3)*], caution should be exercised when **RESTASIS**[®] is administered to a nursing woman. The developmental and health benefits of breastfeeding should be considered along with the mother's clinical need for **RESTASIS**[®] and any potential adverse effects on the breast-fed child from cyclosporine.

8.4 Pediatric Use

Safety and efficacy have not been established in pediatric patients below the age of 16.

8.5 Geriatric Use

No overall difference in safety or effectiveness has been observed between elderly and younger patients.

11 DESCRIPTION

RESTASIS[®] (cyclosporine ophthalmic emulsion) 0.05% contains a topical calcineurin inhibitor immunosuppressant with anti-inflammatory effects. Cyclosporine's chemical name is Cyclo[[*(E)*-(2*S*,3*R*,4*R*)-3-hydroxy-4-methyl-2-(methylamino)-6-octenoyl]-L-2-aminobutyryl-*N*-methylglycyl-*N*-methyl-L-leucyl-L-valyl-*N*-methyl-L-leucyl-L-alanyl-D-alanyl-*N*-methyl-L-leucyl-*N*-methyl-L-leucyl-*N*-methyl-L-valyl] and it has the following structure:

Structural Formula

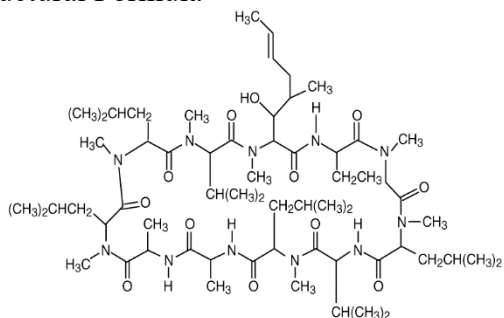

Formula: C₆₂H₁₁₁N₁₁O₁₂ Mol. Wt.: 1202.6

Cyclosporine is a fine white powder. **RESTASIS**[®] appears as a white opaque to slightly translucent homogeneous emulsion. It has an osmolality of 230 to 320 mOsmol/kg and a pH of 6.5-8.0. Each mL of **RESTASIS**[®] ophthalmic emulsion contains: **Active:** cyclosporine 0.05%. **Inactives:** glycerin; castor oil; polysorbate 80; carbomer copolymer type A; purified water; and sodium hydroxide to adjust pH.

12 CLINICAL PHARMACOLOGY

12.1 Mechanism of Action

Cyclosporine is an immunosuppressive agent when administered systemically.

In patients whose tear production is presumed to be suppressed due to ocular inflammation associated with keratoconjunctivitis sicca, cyclosporine emulsion is thought to act as a partial immunomodulator. The exact mechanism of action is not known.

12.3 Pharmacokinetics

Blood cyclosporine A concentrations were measured using a specific high pressure liquid chromatography-mass spectrometry assay. Blood concentrations of cyclosporine, in all the samples collected, after topical administration of **RESTASIS**[®] 0.05%, twice daily, in humans for up to 12 months, were below the quantitation limit of 0.1 ng/mL. There was no detectable drug accumulation in blood during 12 months of treatment with **RESTASIS**[®] ophthalmic emulsion.

13 NONCLINICAL TOXICOLOGY

13.1 Carcinogenesis, Mutagenesis, Impairment of Fertility

Carcinogenesis

Systemic carcinogenicity studies were conducted in male and female mice and rats. In the 78-week oral (diet) mouse study, at doses of 1, 4, and 16 mg/kg/day, evidence of a statistically significant trend was found for lymphocytic lymphomas in females, and the incidence of hepatocellular carcinomas in mid-dose males significantly exceeded the control value.

In the 24-month oral (diet) rat study, conducted at 0.5, 2, and 8 mg/kg/day, pancreatic islet cell adenomas significantly exceeded the control rate in the low dose level. The hepatocellular carcinomas and pancreatic islet cell adenomas were not dose related. The low doses in mice and rats are approximately 80 times greater (normalized to body surface area) than the daily recommended human dose of one drop (approximately 28 mcL) of 0.05% **RESTASIS**[®] twice daily into each eye of a 60 kg person (0.001 mg/kg/day), assuming that the entire dose is absorbed.

Mutagenesis

Cyclosporine has not been found to be mutagenic/genotoxic in the Ames Test, the V79-HGPRT Test, the micronucleus test in mice and Chinese hamsters, the chromosome-aberration tests in Chinese hamster bone-marrow, the mouse dominant lethal assay, and the DNA-repair test in sperm from treated mice. A study analyzing sister chromatid exchange (SCE) induction by cyclosporine using human lymphocytes *in vitro* gave indication of a positive effect (i.e., induction of SCE).

Impairment of Fertility

No impairment in fertility was demonstrated in studies in male and female rats receiving oral doses of cyclosporine up to 15 mg/kg/day (approximately 2,000 times the human daily dose of 0.001 mg/kg/day normalized to body surface area) for 9 weeks (male) and 2 weeks (female) prior to mating.

14 CLINICAL STUDIES

Four multicenter, randomized, adequate and well-controlled clinical studies were performed in approximately 1,200 patients with moderate to severe keratoconjunctivitis sicca. **RESTASIS**[®] demonstrated statistically significant increases in Schirmer wetting of 10 mm versus vehicle at six months in patients whose tear production was presumed to be suppressed due to ocular inflammation. This effect was seen in approximately 15% of **RESTASIS**[®] ophthalmic emulsion-treated patients versus approximately 5% of vehicle-treated patients. Increased tear production was not seen in patients currently taking topical anti-inflammatory drugs or using punctal plugs.

No increase in bacterial or fungal ocular infections was reported following administration of **RESTASIS**[®].

16 HOW SUPPLIED/STORAGE AND HANDLING

RESTASIS[®] ophthalmic emulsion is packaged in sterile, preservative-free single-use vials. Each vial contains 0.4 mL fill in a 0.9 mL LDPE vial; 30 or 60 vials are packaged in a polypropylene tray with an aluminum peelable lid. The entire contents of each tray (30 vials or 60 vials) must be dispensed intact.

30 Vials 0.4 mL each - NDC 0023-9163-30

60 Vials 0.4 mL each - NDC 0023-9163-60

Storage: Store at 15°-25 °C (59°-77 °F).

17 PATIENT COUNSELING INFORMATION

Handling the Container

Advise patients to not allow the tip of the vial to touch the eye or any surface, as this may contaminate the emulsion. Advise patients to not touch the vial tip to their eye to avoid the potential for injury to the eye [*see Warnings and Precautions (5.1)*].

Use with Contact Lenses

RESTASIS[®] should not be administered while wearing contact lenses. Patients with decreased tear production typically should not wear contact lenses. Advise patients that if contact lenses are worn, they should be removed prior to the administration of the emulsion. Lenses may be reinserted 15 minutes following administration of **RESTASIS**[®] ophthalmic emulsion [*see Warnings and Precautions (5.2)*].

Administration

Advise patients that the emulsion from one individual single-use vial is to be used immediately after opening for administration to one or both eyes, and the remaining contents should be discarded immediately after administration.

© YYYY Allergan. All rights reserved.

Irvine, CA 92612, U.S.A.

All trademarks are the property of their respective owners.

Patented. See www.allergan.com/patents

Made in the U.S.A.



HIGHLIGHTS OF PRESCRIBING INFORMATION

These highlights do not include all the information needed to use RESTASIS MULTIDOSE™ safely and effectively. See full prescribing information for RESTASIS MULTIDOSE™.

**RESTASIS MULTIDOSE™ (cyclosporine ophthalmic emulsion) 0.05%
For topical ophthalmic use
Initial U.S. Approval: 1983**

INDICATIONS AND USAGE

RESTASIS MULTIDOSE™ is a calcineurin inhibitor immunosuppressant indicated to increase tear production in patients whose tear production is presumed to be suppressed due to ocular inflammation associated with keratoconjunctivitis sicca. Increased tear production was not seen in patients currently taking topical anti-inflammatory drugs or using punctal plugs. (1)

DOSAGE AND ADMINISTRATION

- Prime by squeezing two drops onto a tissue before initial use. (2.1)
- Instill one drop of RESTASIS MULTIDOSE™ ophthalmic emulsion twice a day in each eye approximately 12 hours apart. (2.2)

DOSAGE FORMS AND STRENGTHS

Cyclosporine ophthalmic emulsion 0.5 mg/mL (3)

CONTRAINDICATIONS

- Hypersensitivity (4)

WARNINGS AND PRECAUTIONS

- To avoid the potential for eye injury and contamination, be careful not to touch the bottle tip to your eye or other surfaces. (5.1)

ADVERSE REACTIONS

The most common adverse reaction following the use of cyclosporine ophthalmic emulsion 0.05% was ocular burning (17%). (6.1)

To report SUSPECTED ADVERSE REACTIONS, contact Allergan, Inc. at 1-800-433-8871 or FDA at 1-800-FDA-1088 or www.fda.gov/medwatch.

See 17 for PATIENT COUNSELING INFORMATION and FDA-approved patient labeling.

Revised: 10/2016

FULL PRESCRIBING INFORMATION: CONTENTS*

1 INDICATIONS AND USAGE

2 DOSAGE AND ADMINISTRATION

- 2.1 Preparation for First-Time Use
- 2.2 Preparation for Use

3 DOSAGE FORMS AND STRENGTHS

4 CONTRAINDICATIONS

5 WARNINGS AND PRECAUTIONS

- 5.1 Potential for Eye Injury and Contamination
- 5.2 Use with Contact Lenses

6 ADVERSE REACTIONS

- 6.1 Clinical Trials Experience
- 6.2 Post-marketing Experience

8 USE IN SPECIFIC POPULATIONS

- 8.1 Pregnancy
- 8.2 Lactation
- 8.4 Pediatric Use
- 8.5 Geriatric Use

11 DESCRIPTION

12 CLINICAL PHARMACOLOGY

- 12.1 Mechanism of Action
- 12.3 Pharmacokinetics

13 NONCLINICAL TOXICOLOGY

- 13.1 Carcinogenesis, Mutagenesis, Impairment of Fertility

14 CLINICAL STUDIES

16 HOW SUPPLIED/STORAGE AND HANDLING

17 PATIENT COUNSELING INFORMATION

* Sections or subsections omitted from the full prescribing information are not listed.

FULL PRESCRIBING INFORMATION

1 INDICATIONS AND USAGE

RESTASIS MULTIDOSE™ ophthalmic emulsion is indicated to increase tear production in patients whose tear production is presumed to be suppressed due to ocular inflammation associated with keratoconjunctivitis sicca. Increased tear production was not seen in patients currently taking topical anti-inflammatory drugs or using punctal plugs.

2 DOSAGE AND ADMINISTRATION

Instill one drop of **RESTASIS MULTIDOSE™** ophthalmic emulsion twice a day in each eye approximately 12 hours apart. **RESTASIS MULTIDOSE™** can be used concomitantly with lubricant eye drops, allowing a 15-minute interval between products.

2.1 Preparation for First-Time Use

Step 1: Pull off the clear shipping cover by pulling straight up. Throw the shipping cover away.

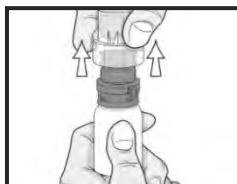

Do not use **RESTASIS MULTIDOSE™** if shipping cover or pull tab are damaged or missing.

Step 2: Remove the pull tab on the olive green colored protective cap by pulling the end of the pull tab away from the bottle then winding it counterclockwise. Throw away the pull tab.



Step 3: Remove the olive green colored protective cap by pulling it straight up. Keep the colored protective cap.



Step 4: Prime the bottle for first-time use by squeezing two drops onto a tissue. Do not let the bottle tip touch the tissue.



Step 5: The bottle is now ready for use. After use, recap the bottle with the olive green colored protective cap by pushing it straight down onto the bottle.



2.2 Preparation for Use

Step 6: Turn the bottle upside down a few times before giving your dose to make sure the medicine is mixed well.



Step 7: Instill one drop in the affected eye. Replace the olive green colored protective cap.

3 DOSAGE FORMS AND STRENGTHS

Ophthalmic emulsion containing cyclosporine 0.5 mg/mL

4 CONTRAINDICATIONS

RESTASIS MULTIDOSE™ is contraindicated in patients with known or suspected hypersensitivity to any of the ingredients in the formulation [*see Adverse Reactions (6.2)*].

5 WARNINGS AND PRECAUTIONS

5.1 Potential for Eye Injury and Contamination

Be careful not to touch the bottle tip to your eye or other surfaces to avoid potential for eye injury and contamination.

5.2 Uses with Contact Lenses

RESTASIS MULTIDOSE™ should not be administered while wearing contact lenses. Patients with decreased tear production typically should not wear contact lenses. If contact lenses are worn, they should be removed prior to the administration of the emulsion. Lenses may be reinserted 15 minutes following administration of **RESTASIS MULTIDOSE™** ophthalmic emulsion.

6 ADVERSE REACTIONS

The following serious adverse reactions are described elsewhere in the labeling:

- Potential for Eye Injury and Contamination [*see Warnings and Precautions (5.1)*]

6.1 Clinical Trials Experience

Because clinical trials are conducted under widely varying conditions, adverse reaction rates observed in the clinical trials of a drug cannot be directly compared to rates in the clinical trials of another drug and may not reflect the rates observed in practice.

In clinical trials, the most common adverse reaction following the use of cyclosporine ophthalmic emulsion, 0.05% was ocular burning (17%).

Other reactions reported in 1% to 5% of patients included conjunctival hyperemia, discharge, epiphora, eye pain, foreign body sensation, pruritus, stinging, and visual disturbance (most often blurring).

6.2 Post-marketing Experience

The following adverse reactions have been identified during post approval use of cyclosporine ophthalmic emulsion, 0.05%. Because these reactions are reported voluntarily from a population of uncertain size, it is not always possible to reliably estimate their frequency or establish a causal relationship to drug exposure.

Reported reactions have included: hypersensitivity (including eye swelling, urticaria, rare cases of severe angioedema, face swelling, tongue swelling, pharyngeal edema, and dyspnea); and superficial injury of the eye (from the bottle tip touching the eye during administration).

8 USE IN SPECIFIC POPULATIONS

8.1 Pregnancy

Risk Summary

Clinical administration of cyclosporine ophthalmic emulsion 0.05% is not detected systemically following topical ocular administration [*see Clinical Pharmacology (12.3)*], and maternal use is not expected to result in fetal exposure to the drug. Oral administration of cyclosporine to pregnant rats or rabbits did not produce teratogenicity at clinically relevant doses [*see Data*].

Data

Animal Data

At maternally toxic doses (30 mg/kg/day in rats and 100 mg/kg/day in rabbits), cyclosporine oral solution (USP) was teratogenic as indicated by increased pre- and postnatal mortality, reduced fetal weight and skeletal retardations. These doses (normalized to body surface area) are 5,000 and 32,000 times greater, respectively, than the daily recommended human dose of one drop (approximately 28 mL) of cyclosporine ophthalmic emulsion 0.05% twice daily into each eye of a 60 kg person (0.001 mg/kg/day), assuming that the entire dose is absorbed. No evidence of embryofetal toxicity was observed in rats or rabbits receiving cyclosporine during organogenesis at oral doses up to 17 mg/kg/day or 30 mg/kg/day, respectively. These doses in rats and rabbits are approximately 3,000 and 10,000 times greater, respectively, than the daily recommended human dose.

An oral dose of 45 mg/kg/day cyclosporine administered to rats from Day 15 of pregnancy until Day 21 postpartum produced maternal toxicity and an increase in postnatal mortality in offspring. This dose is 7,000 times greater than the daily recommended human dose. No adverse effects in dams or offspring were observed at oral doses up to 15 mg/kg/day (2,000 times greater than the daily recommended human dose).

8.2 Lactation

Risk Summary

Cyclosporine is known to appear in human milk following systemic administration, but its presence in human milk following topical treatment has not been investigated. Although blood concentrations are undetectable following topical administration of cyclosporine ophthalmic emulsion 0.05% [see *Clinical Pharmacology (12.3)*], caution should be exercised when **RESTASIS MULTIDOSE™** is administered to a nursing woman. The developmental and health benefits of breastfeeding should be considered along with the mother's clinical need for **RESTASIS MULTIDOSE™** and any potential adverse effects on the breast-fed child from cyclosporine.

8.4 Pediatric Use

Safety and efficacy have not been established in pediatric patients below the age of 16.

8.5 Geriatric Use

No overall difference in safety or effectiveness has been observed between elderly and younger patients.

11 DESCRIPTION

RESTASIS MULTIDOSE™ (cyclosporine ophthalmic emulsion) 0.05% contains a calcineurin inhibitor immunosuppressant with anti-inflammatory effects. Cyclosporine's chemical name is Cyclo[[*(E)*-(2*S*,3*R*,4*R*)-3-hydroxy-4-methyl-2-(methylamino)-6-octenyl]-L-2-aminobutyryl-*N*-methylglycyl-*N*-methyl-L-leucyl-L-valyl-*N*-methyl-L-leucyl-L-alanyl-D-alanyl-*N*-methyl-L-leucyl-*N*-methyl-L-leucyl-*N*-methyl-L-valyl] and it has the following structure:

Structural Formula

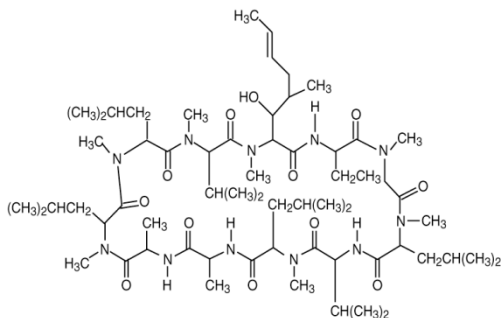

Formula: C₆₂H₁₁₁N₁₁O₁₂ Mol. Wt.: 1202.6

Cyclosporine is a fine white powder. **RESTASIS MULTIDOSE™** appears as a white opaque to slightly translucent homogeneous emulsion. It has an osmolality of 230 to 320 mOsmol/kg and a pH of 6.5-8.0. Each mL of **RESTASIS MULTIDOSE™** ophthalmic emulsion contains: **Active:** cyclosporine 0.05%. **Inactives:** glycerin; castor oil; polysorbate 80; carbomer copolymer type A; purified water; and sodium hydroxide to adjust pH.

12 CLINICAL PHARMACOLOGY

12.1 Mechanism of Action

Cyclosporine is an immunosuppressive agent when administered systemically.

In patients whose tear production is presumed to be suppressed due to ocular inflammation associated with keratoconjunctivitis sicca, cyclosporine emulsion is thought to act as a partial immunomodulator. The exact mechanism of action is not known.

12.3 Pharmacokinetics

Blood cyclosporine A concentrations were measured using a specific high pressure liquid chromatography-mass spectrometry assay. Blood concentrations of cyclosporine, in all the samples collected, after topical administration of cyclosporine ophthalmic emulsion, 0.05%, twice daily, in humans for up to 12 months, were below the quantitation limit of 0.1 ng/mL. There was no detectable drug accumulation in blood during 12 months of treatment with cyclosporine ophthalmic emulsion, 0.05%.

13 NONCLINICAL TOXICOLOGY

13.1 Carcinogenesis, Mutagenesis, Impairment of Fertility

Carcinogenesis

Systemic carcinogenicity studies were conducted in male and female mice and rats. In the 78-week oral (diet) mouse study, at doses of 1, 4, and 16 mg/kg/day, evidence of a statistically significant trend was found for lymphocytic lymphomas in females, and the incidence of hepatocellular carcinomas in mid-dose males significantly exceeded the control value.

In the 24-month oral (diet) rat study, conducted at 0.5, 2, and 8 mg/kg/day, pancreatic islet cell adenomas significantly exceeded the control rate in the low dose level. The hepatocellular carcinomas and pancreatic islet cell adenomas were not dose related. The low doses in mice and rats are approximately 80 times greater (normalized to body surface area) than the daily recommended human dose of one drop (approximately 28 mcL) of cyclosporine ophthalmic emulsion, 0.05% twice daily into each eye of a 60 kg person (0.001 mg/kg/day), assuming that the entire dose is absorbed.

Mutagenesis

Cyclosporine has not been found to be mutagenic/genotoxic in the Ames Test, the V79-HGPRT Test, the micronucleus test in mice and Chinese hamsters, the chromosome-aberration tests in Chinese hamster bone-marrow, the mouse dominant lethal assay, and the DNA-repair test in sperm from treated mice. A study analyzing sister chromatid exchange (SCE) induction by cyclosporine using human lymphocytes *in vitro* gave indication of a positive effect (i.e., induction of SCE).

Impairment of Fertility

No impairment in fertility was demonstrated in studies in male and female rats receiving oral doses of cyclosporine up to 15 mg/kg/day (approximately 2,000 times the human daily dose of 0.001 mg/kg/day normalized to body surface area) for 9 weeks (male) and 2 weeks (female) prior to mating.

14 CLINICAL STUDIES

Four multicenter, randomized, adequate and well-controlled clinical studies were performed in approximately 1,200 patients with moderate to severe keratoconjunctivitis sicca. Cyclosporine ophthalmic emulsion, 0.05% demonstrated statistically significant increases in Schirmer wetting of 10 mm versus vehicle at six months in patients whose tear production was presumed to be suppressed due to ocular inflammation. This effect was seen in approximately 15% of

cyclosporine ophthalmic emulsion, 0.05%-treated patients versus approximately 5% of vehicle-treated patients. Increased tear production was not seen in patients currently taking topical anti-inflammatory drugs or using punctal plugs.

No increase in bacterial or fungal ocular infections was reported following administration of cyclosporine ophthalmic emulsion, 0.05%.

16 HOW SUPPLIED/STORAGE AND HANDLING

RESTASIS MULTIDOSE™ ophthalmic emulsion is packaged in a sterile, multi-dose preservative-free bottle. Each bottle consists of a white opaque LDPE bottle, a white opaque polypropylene top with unidirectional valve and air filter, a protective olive green polypropylene cap, and a clear disposable shipping cover over the colored cap.

5.5 mL in 10-mL bottle - NDC 0023-9163-05

Storage: Store at 15-25 °C (59-77 °F).

17 PATIENT COUNSELING INFORMATION

Handling the Container

Advise patients to not allow the tip of the bottle to touch the eye or any surface, as this may contaminate the emulsion. Advise patients to not touch the bottle tip to their eye to avoid the potential for injury to the eye [*see Warnings and Precautions (5.1)*].

Use with Contact Lenses

RESTASIS MULTIDOSE™ should not be administered while wearing contact lenses. Patients with decreased tear production typically should not wear contact lenses. Advise patients that if contact lenses are worn, they should be removed prior to the administration of the emulsion. Lenses may be reinserted 15 minutes following administration of **RESTASIS MULTIDOSE™** ophthalmic emulsion [*see Warnings and Precautions (5.2)*].

Administration

Advise patients to read the “Instructions for Use” for detailed first-time use instructions.

© 2016 Allergan. All rights reserved.

Irvine, CA 92612, U.S.A.

All trademarks are the property of their respective owners.

Patented: See: www.allergan.com/products/patents

Made in Ireland.



INSTRUCTIONS FOR USE
RESTASIS MULTIDOSE™ (Re stay' sis Mul tee dōs)
(cyclosporine ophthalmic emulsion) 0.05%

Read this Instructions for Use before you start using **RESTASIS MULTIDOSE™** and each time you get a refill. There may be new information. This leaflet does not take the place of talking to your healthcare provider about your medical condition or treatment.

Important:

- **RESTASIS MULTIDOSE™** is for use in the eye
- Wash your hands before using **RESTASIS MULTIDOSE™**.
- Do not let the bottle tip touch the eye or any other surfaces to avoid contamination or injury to your eye.
- Use 1 drop of **RESTASIS MULTIDOSE™** in each eye, 2 times each day, about 12 hours apart.
- If you wear contact lenses, remove them before using **RESTASIS MULTIDOSE™**. Wait for at least 15 minutes before placing them back in your eyes.
- **RESTASIS MULTIDOSE™** can be used with lubricant eye drops, but you should wait at least 15 minutes between using each product.

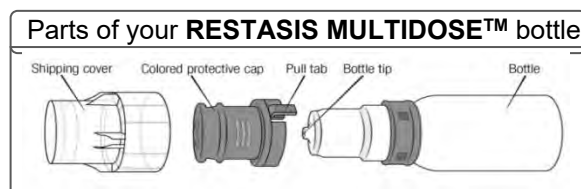

PREPARING THE BOTTLE FOR FIRST-TIME USE:

Step 1: Pull off shipping cover by pulling straight up. Throw the shipping cover away. **Do not use RESTASIS MULTIDOSE™** if shipping cover or pull tab are damaged or missing.



Step 2: Remove the pull tab on the olive green colored protective cap by pulling the end of the pull tab away from the bottle then winding it counterclockwise. Throw away the pull tab.



Step 3: Remove the olive green colored protective cap by pulling it straight up. Keep the colored protective cap.

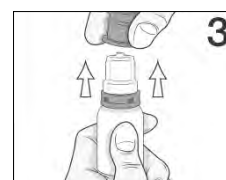

Step 4: Prime the bottle for first time use by squeezing 2 drops onto a tissue. Do not let the bottle tip touch the tissue.

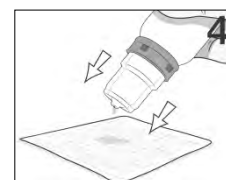

Step 5: The bottle is now ready for use. After use, recap the bottle with the olive green colored protective cap by pushing straight down onto the bottle.



GIVING YOUR DOSE:

Step 6: Turn the bottle upside down a few times before giving your dose to make sure the medicine is mixed well.

Step 7: Instill one drop in the affected eye. Replace the olive green colored protective cap.

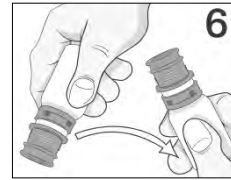

How do I store RESTASIS MULTIDOSE™?

- Store RESTASIS MULTIDOSE™ between 15-25 °C (59-77 °F).

Keep RESTASIS MULTIDOSE™ and all medicines out of the reach of children.

This Instructions for Use has been approved by the Food and Drug Administration.

© 2016 Allergan. All rights reserved. Irvine, CA 92612, U.S.A.
All trademarks are the property of their respective owners. Patented: See: www.allergan.com/products/patents Made in Ireland.



Approved: 10/2016

PRODUCT MONOGRAPH

PrREVOLADE[®]

Eltrombopag

12.5 mg, 25 mg, 50 mg and 75 mg Eltrombopag (as Eltrombopag Olamine) Tablets

Thrombopoietin Receptor Agonist (B02BX05)

Novartis Pharmaceuticals Canada Inc.
385 Bouchard Blvd.
Dorval, Quebec
H9S 1A9

Date of Revision:
May 15, 2019

Submission Control No: 217802

REVOLADE is a registered trademark

TABLE OF CONTENTS

PART I: HEALTH PROFESSIONAL INFORMATION.....	3
SUMMARY PRODUCT INFORMATION	3
INDICATIONS AND CLINICAL USE	3
CONTRAINDICATIONS	4
WARNINGS AND PRECAUTIONS	4
ADVERSE REACTIONS.....	13
DRUG INTERACTIONS	27
DOSAGE AND ADMINISTRATION	29
OVERDOSAGE.....	38
ACTION AND CLINICAL PHARMACOLOGY.....	39
STORAGE AND STABILITY.....	43
DOSAGE FORMS, COMPOSITION AND PACKAGING	43
PART II: SCIENTIFIC INFORMATION	44
PHARMACEUTICAL INFORMATION	44
CLINICAL TRIALS.....	45
DETAILED PHARMACOLOGY	61
TOXICOLOGY	63
REFERENCES	67
PART III: CONSUMER INFORMATION	68

Pr**REVOLADE**[®]

Eltrombopag Tablets
12.5 mg, 25 mg, 50 mg and 75 mg Eltrombopag (as Eltrombopag Olamine) Tablets

PART I: HEALTH PROFESSIONAL INFORMATION

SUMMARY PRODUCT INFORMATION

Route of Administration	Dosage Form / Strength	All Nonmedicinal Ingredients
Oral	Tablets/12.5 mg, 25 mg, 50 mg and 75 mg eltrombopag (as eltrombopag olamine)	Please refer to DOSAGE FORMS, COMPOSITION AND PACKAGING.

INDICATIONS AND CLINICAL USE

REVOLADE (eltrombopag) tablets are indicated for the treatment of chronic immune thrombocytopenia (ITP) to increase platelet counts in adult and pediatric patients one year and older who have had an insufficient response to corticosteroids or immunoglobulins.

The median duration of treatment with REVOLADE in pediatric clinical trials was 5.6 months with a minimum duration of 0.5 months and a maximum duration of 9.0 months. The long-term safety and efficacy of REVOLADE have not been established in pediatric ITP patients.

REVOLADE is indicated to increase platelet counts in thrombocytopenic patients with chronic hepatitis C virus (HCV) infection to allow the initiation and maintenance of interferon-based therapy.

REVOLADE is indicated for the treatment of adult patients with severe aplastic anemia (SAA) who have had an insufficient response to immunosuppressive therapy.

Pediatrics (< 18 years of age):

The safety and efficacy of REVOLADE have not been established in pediatric ITP patients younger than 1 year. In pediatric clinical trials, patients between 1 to 5 years of

age were administered REVOLADE as powder for oral suspension (see **CLINICAL TRIALS**). REVOLADE is only available as tablets and cannot be used in patients who are unable to swallow REVOLADE tablets whole (see **WARNINGS AND PRECAUTIONS**). The safety and efficacy of REVOLADE in pediatric patients with chronic HCV or SAA have not been established.

Geriatrics (≥ 65 years of age):

Clinical studies of REVOLADE did not include sufficient numbers of patients aged 65 and older to determine whether they respond differently from younger patients. In general, caution should be exercised in the administration and monitoring of REVOLADE in elderly patients, reflecting the greater frequency of decreased hepatic, renal or cardiac function and of concomitant disease or other drug therapy.

CONTRAINDICATIONS

REVOLADE (eltrombopag) is contraindicated in patients

- with severe hepatic impairment (Child-Pugh Class C) (see **WARNINGS AND PRECAUTIONS, Hepatic, Hepatic Impairment, and Hepatotoxicity**)
- who are hypersensitive to REVOLADE or to any of its excipients. For a complete listing of excipients (see **DOSAGE FORMS, COMPOSITION AND PACKAGING**)

In patients with chronic hepatitis C virus (HCV) infection, the Product Monographs for both pegylated interferon and ribavirin should be consulted for relevant contraindications associated with the use of these products.

WARNINGS AND PRECAUTIONS

Serious Warnings and Precautions

REVOLADE should be used with caution in chronic hepatitis C patients with cirrhosis as it may increase the risk of hepatic decompensation and death when administered with pegylated interferon and ribavirin. Patients with low albumin levels (<35 g/L) or Model for End-Stage Liver Disease (MELD) score ≥ 10 at baseline had a greater risk of hepatic decompensation. Patients with these characteristics should be closely monitored for signs and symptoms of hepatic decompensation (see **WARNINGS AND PRECAUTIONS, Hepatic, Hepatic Decompensation - Use with Interferon**).

REVOLADE is only available as tablets and should not be used in patients who are unable to swallow REVOLADE tablets whole (see **DOSAGE AND ADMINISTRATION, Dosing Considerations**).

General

The diagnosis of ITP in pediatric patients as well as adults and elderly patients should be confirmed by exclusion of other clinical entities presenting with thrombocytopenia. The effectiveness and safety of REVOLADE (eltrombopag) have not been established for use in other thrombocytopenic conditions including chemotherapy-induced thrombocytopenia and myelodysplastic syndromes (MDS). There is a theoretical concern that thrombopoietin receptor agonists, including REVOLADE, may stimulate the progression of existing hematopoietic malignancies such as MDS (see **Hematologic malignancies** below). Consideration should be given to performing a bone marrow aspirate and biopsy over the course of the disease and treatment, particularly in patients over 60 years of age, those with systemic symptoms or abnormal signs such as increased peripheral blast cell.

In patients with chronic hepatitis C virus (HCV) infection, the Product Monographs for both pegylated interferon and ribavirin should be consulted for relevant warnings and precautions associated with the use of these products.

The safety and efficacy of REVOLADE has not been established in combination with direct acting antiviral agents used in the treatment of chronic hepatitis C virus (see **DRUG INTERACTIONS, Drug-Drug Interactions, HCV Protease Inhibitors**).

Hematologic

Thrombotic or thromboembolic complications: Platelet counts above the normal range may present an increased risk of thrombotic complications. Thromboembolic events (TEE) were observed at low and normal platelet counts.

The risk of TEE, such as portal vein thrombosis, has been found to be increased in patients with chronic liver disease treated with 75 mg REVOLADE once daily for two weeks in preparation for invasive procedures. Therefore, REVOLADE should not be used in ITP and SAA patients with hepatic impairment (Child-Pugh Class A and B) unless the expected benefit outweighs the identified risk of portal venous thrombosis, an adverse event which may lead to death (see **DOSAGE AND ADMINISTRATION**).

In adult clinical trials with REVOLADE in ITP (n = 763), 30 patients experienced a total of 34 TEEs (a patient may have experienced more than 1 TEE), which included deep vein thrombosis (n = 10), pulmonary embolism (n = 7), acute myocardial infarction (n = 3), cerebral infarction (n = 7), transient ischemic attack (n=3), cerebral venous thrombosis (n=1), embolic cerebral infarction (n=1), embolism (n = 1), and transverse sinus thrombosis (n=1). TEEs were observed at low and normal platelet counts.

In controlled studies in thrombocytopenic patients with HCV receiving interferon-based therapy (n = 1439), 38 out of 955 patients (4 %) treated with REVOLADE and 6 out of 484 patients (1%) in the placebo group experienced TEEs. Reported thrombotic/thromboembolic complications included both venous and arterial events. The majority of TEEs were non-serious and resolved by the end of the study. Portal vein thrombosis was the most common TEE in both treatment groups (2% in patients treated

with REVOLADE versus < 1% for placebo). No specific temporal relationship between start of treatment and occurrence of TEE was observed. Patients with low albumin levels (≤ 35 g/L), MELD score ≥ 10 , or age greater than 60 years demonstrated an increased risk of TEE. REVOLADE should only be administered to such patients after careful consideration of the expected benefits in comparison with the risks. Patients should be closely monitored for signs and symptoms of TEEs.

During clinical trial and post-market experience, cases of thrombotic microangiopathy with acute renal failure were reported in association with REVOLADE administration in ITP patients. Renal function recovered partially with discontinuation of REVOLADE and in one case renal function worsened on treatment. In some of these reported cases of thrombotic microangiopathy with acute renal failure the patients had concurrent risk factors for thromboembolism (e.g. antiphospholipid syndrome and systemic lupus erythematosus).

Caution should be used when administering REVOLADE to patients with known risk factors for thromboembolism including but not limited to inherited (e.g. Factor V Leiden) or acquired risk factors (e.g. ATIII deficiency, antiphospholipid syndrome and systemic lupus erythematosus), advanced age, patients with prolonged periods of immobilisation, malignancies, contraceptives and hormone replacement therapy, surgery/trauma, obesity and smoking. Platelet counts should be closely monitored and consideration given to reducing the dose or discontinuing REVOLADE if the platelet count exceeds the target levels (see **DOSAGE and ADMINISTRATION**). The risk-benefit balance should be considered in patients at risk of TEEs of any aetiology.

Re-occurrence of thrombocytopenia following discontinuation of REVOLADE: Thrombocytopenia is likely to reoccur upon discontinuation of treatment with REVOLADE in ITP patients. Following discontinuation of REVOLADE, platelet counts return to baseline levels within 2 weeks in the majority of patients (see **CLINICAL TRIALS**), which increases the bleeding risk and in some cases may lead to bleeding. This risk is increased if REVOLADE is discontinued in the presence of anticoagulants or antiplatelet agents. It is recommended that, if treatment with REVOLADE is discontinued, ITP treatment be restarted according to current treatment guidelines. Additional medical management may include cessation of anticoagulant and/or antiplatelet therapy, reversal of anticoagulation, or platelet support. Platelet counts must be monitored weekly for 4 weeks following discontinuation of REVOLADE.

Bone marrow reticulin formation and risk of bone marrow fibrosis: Thrombopoietin receptor (TPO-R) agonists, including REVOLADE, may increase the risk for development or progression of reticulin fibers within the bone marrow.

In a longitudinal 2-year bone marrow study with 162 previously treated adults with ITP, where serial bone marrow biopsies from baseline and after 1 and 2 years of treatment with eltrombopag were compared, results showed increases from baseline in bone marrow fibrosis grade and development of collagen fibres while on treatment in some patients (see **ADVERSE REACTIONS, Bone Marrow Reticulin Formation**). In the 4 patients who had post-treatment biopsies performed to assess the reversibility in fibrosis,

3 had post-treatment biopsies that showed a lower bone marrow fibrosis grade after discontinuation of treatment. The clinical relevance of these findings has not been established. None of the patients had clinical symptoms typical of bone marrow dysfunction or abnormalities of clinical concern reported in the complete blood count or peripheral blood smear.

In the adult ITP clinical trials 3 patients discontinued eltrombopag treatment due to bone marrow reticulin deposition.

Prior to initiation of REVOLADE, examine the peripheral blood smear closely to establish a baseline level of cellular morphologic abnormalities. Following identification of a stable dose of REVOLADE, examine peripheral blood smears and complete blood counts (CBC) monthly for new or worsening morphological abnormalities (e.g., teardrop and nucleated red blood cells, immature white blood cells) or cytopenia(s). If the patient develops new or worsening morphological abnormalities or cytopenia(s), discontinue treatment with REVOLADE and consider a bone marrow biopsy, including staining for fibrosis.

Cytogenetic abnormalities: Cytogenetic abnormalities are known to occur in SAA patients. It is not known whether REVOLADE increases the risk of cytogenetic abnormalities in patients with SAA. In the phase II SAA clinical study with REVOLADE, the incidence of new cytogenetic abnormalities was observed in 19% of patients [8/43 (where 5 of them had changes in chromosome 7)]. The median time on study to a cytogenetic abnormality was 2.9 months.

For SAA patients who have an insufficient response to immunosuppressive therapy, bone marrow examination with aspirations for cytogenetics is recommended prior to initiation of REVOLADE, at 3 months of treatment and 6 months thereafter. Discontinuation of REVOLADE should be considered if new cytogenetic abnormalities are observed.

Hematologic malignancies: TPO-R agonists are growth factors that lead to thrombopoietic progenitor cell expansion, differentiation and platelet production. The TPO-R is predominantly expressed on the surface of cells of the myeloid lineage. For TPO-R agonists there is a theoretical concern that they may stimulate the progression of existing hematopoietic malignancies such as myelodysplasia (MDS). The effectiveness and safety of REVOLADE have not been established for the treatment of thrombocytopenia due to MDS.

Increased risk of death and progression of myelodysplastic syndromes (MDS) to acute myeloid leukemia (AML) were observed in a randomized, double-blind, placebo-controlled, multicenter trial in patients with International Prognostic Scoring System (IPSS) intermediate-1, intermediate-2 or high risk MDS with thrombocytopenia, receiving azacitidine in combination with either REVOLADE or placebo. This trial was terminated due to lack of efficacy and safety reasons, including increased progression to AML. Patients received REVOLADE or placebo at a starting dose of 200 mg once daily, up to a maximum of 300 mg once daily, in combination with azacitidine for at least six cycles. The incidence of death (overall survival) was 32% (57/179) in the REVOLADE

arm versus 29% (51/177) in the placebo arm (HR [95% CI] = 1.42 [0.97, 2.08], showing an increased relative risk of death in this trial by 42% in the REVOLADE arm). The incidence of progression to AML was 12% (21/179) in the REVOLADE arm versus 6% (10/177) in the placebo arm (HR [95% CI] = 2.66 [1.312, 5.41], showing an increased relative risk of progression to AML in this trial by 166% in the REVOLADE arm).

In clinical trials with REVOLADE in SAA, 5% of patients (4/73) were diagnosed with MDS. The median time to diagnosis was 3 months from the start of REVOLADE treatment.

Prior to initiation of REVOLADE, examine the peripheral blood smear closely to establish a baseline level of cellular morphologic abnormalities. Following identification of a stable dose of REVOLADE, examine peripheral blood smears and complete blood counts (CBC) monthly for new or worsening morphological abnormalities (e.g., teardrop and nucleated red blood cells, immature white blood cells) or cytopenia(s). If the patient develops new or worsening morphological abnormalities or cytopenia(s), discontinue treatment with REVOLADE and consider a bone marrow biopsy.

Discontinuation of REVOLADE should be considered if hematologic malignancies develop.

Hepatic

Hepatotoxicity: REVOLADE administration can cause abnormal liver function, severe hepatotoxicity and potentially fatal liver injury.

Cases of severe drug-induced liver injury have been reported during clinical trials and post-marketing. During clinical trials, the elevation of liver laboratory values typically occurred within three months of initiation of REVOLADE; in all cases the events resolved following discontinuation of REVOLADE.

In the controlled clinical studies in adult and pediatric patients (aged 1 to 17 years) with chronic ITP who received REVOLADE (see **CLINICAL TRIALS**), increases in serum alanine aminotransferase (ALT), aspartate aminotransferase (AST) and bilirubin were observed. These findings were mostly mild (Grade 1-2), reversible and not accompanied by clinically significant symptoms that would indicate impaired liver function. Across three placebo-controlled studies in adults with chronic ITP, one patients in the placebo group and one patients in the REVOLADE group experienced a Grade 4 liver test abnormality. In two placebo-controlled studies in pediatric patients (aged 1 to 17 years) with chronic ITP, ALT ≥ 3 times the upper limit of normal (\times ULN) was reported in 5 (4.7%) patients and no (0%) patients in the REVOLADE and placebo groups, respectively. Two of the 5 REVOLADE patients (one White; one South East Asian) had increases in ALT $\geq 5 \times$ ULN. Most hepatobiliary laboratory abnormalities and hepatobiliary adverse events occurred in patients 6-11 years of age. Among 171 pediatric patients who received at least one dose of REVOLADE at any time in either study (median duration of treatment of 171 days), there were an additional 7 patients with ALT $\geq 3 \times$ ULN, among them 5 patients (1 White; 4 Asian) with increases in ALT $\geq 5 \times$ ULN.

In clinical trials in patients with chronic hepatitis C, 11 patients treated with REVOLADE (1%) experienced drug-induced liver injury. In two controlled clinical studies in thrombocytopenic patients with HCV, ALT or AST $\geq 3 \times$ the upper limit of normal (ULN) were reported in 34 % and 38 % of the REVOLADE and placebo groups, respectively. REVOLADE administration in combination with peginterferon/ribavirin therapy is associated with indirect hyperbilirubinaemia. Overall, total bilirubin $\geq 1.5 \times$ ULN was reported in 76 % and 50 % of the REVOLADE and placebo groups, respectively.

In the single-arm phase II monotherapy refractory SAA study, adverse events due to transaminase increases were reported in 26% (11/43) of patients. Concurrent ALT or AST $> 3 \times$ ULN with total (indirect) bilirubin $> 1.5 \times$ ULN were reported in 5% of patients. ALT or AST $> 3 \times$ ULN were reported in 21% of patients and $> 5 \times$ ULN in 9% of patients. Total bilirubin $> 1.5 \times$ ULN occurred in 14% of patients.

Serum ALT, AST and bilirubin should be measured prior to initiation of REVOLADE, every 2 weeks during the dose adjustment phase, and monthly following establishment of a stable dose. Eltrombopag inhibits UGT1A1 and OATP1B1, which may lead to indirect hyperbilirubinemia. If bilirubin is elevated, fractionation should be performed. Abnormal

serum liver tests should be evaluated with repeat testing within 3 to 5 days. If the abnormalities are confirmed, serum liver tests should be monitored until the abnormalities resolve, stabilize, or return to baseline levels. REVOLADE should be discontinued if ALT levels increase ($\geq 3x$ ULN) in patients with normal liver function or $\geq 3x$ baseline (or $> 5 x$ ULN, whichever is the lower) in patients with elevations in transaminases before treatment and that are:

- progressive, or
- persistent for ≥ 4 weeks, or
- accompanied by increased direct bilirubin, or
- accompanied by clinical symptoms of liver injury or evidence for hepatic decompensation.

Hepatic Impairment: Caution should be exercised when administering REVOLADE to patients with any degree of hepatic disease, since exposure to eltrombopag increases with increasing degrees of hepatic impairment (see **ACTION AND CLINICAL PHARMACOLOGY, Special Populations and Conditions, Hepatic Impairment**). REVOLADE should not be used in ITP and SAA patients with mild or moderate hepatic impairment (Child-Pugh Class A and B) unless the expected benefit outweighs the identified risk of portal venous thrombosis, which can lead to death. Use a lower starting dose if REVOLADE is administered to these patients (see **DOSAGE AND ADMINISTRATION, Hepatic Impairment**). No dosage adjustment is necessary for HCV patients with mild or moderate hepatic impairment.

REVOLADE is contraindicated in patients with severe hepatic impairment (see **CONTRAINDICATIONS**). Due to limited data in patients with severe hepatic impairment (Child-Pugh Class C), a risk-benefit profile could not be established in this patient population.

Hepatic Decompensation – Use with Interferon: Chronic hepatitis C virus infected patients with cirrhosis may be at risk of hepatic decompensation and death when receiving therapy with pegylated interferon and ribavirin. In patients with low albumin levels (< 35 g/L) or with a Model for End-Stage Liver Disease (MELD) score ≥ 10 at baseline, there was a 3-fold greater risk of hepatic decompensation, and an increase in the risk of a fatal adverse event compared to those without advanced liver disease.

In two controlled clinical trials in patients with chronic hepatitis C virus infection and thrombocytopenia, adverse events related to hepatic decompensation (ascites, hepatic encephalopathy, variceal hemorrhage, and spontaneous bacterial peritonitis) occurred more frequently in the REVOLADE arm (11%) than in the placebo arm (6%).

REVOLADE should only be administered to such patients after careful consideration of the expected benefits compared to the associated risks. Patients with these characteristics should be closely monitored for signs and symptoms of hepatic decompensation.

Ophthalmologic

Cataracts: In two controlled clinical studies in thrombocytopenic adult patients with HCV (n=1439), receiving interferon therapy, progression of pre-existing baseline cataract(s) or incident cataract was reported in 8 % of patients treated with REVOLADE and 5 % of patients treated with placebo. In one uncontrolled extension study in adult patients with chronic ITP, cataract developed in 9% of patients and was considered a serious adverse event in 5% of patients. Cataracts were observed in toxicology studies of eltrombopag in rodents (see **TOXICOLOGY, Repeat Dose Toxicity**).

In two placebo-controlled studies in pediatric patients (aged 1 to 17 years) with chronic ITP, two cataract events occurred in patients who received at least one dose of REVOLADE at any time on study. In studies in pre-weaning juvenile rats treated with non-tolerated doses and younger mice treated with tolerated doses, ocular opacities have been observed (see **TOXICOLOGY, Juvenile Toxicity**).

Perform a baseline ocular examination prior to administration of REVOLADE, and regularly monitor patients for signs and symptoms of cataracts during therapy with REVOLADE.

Renal

Renal Impairment: Patients with renal impairment may have decreased exposure to eltrombopag (see **ACTION AND CLINICAL PHARMACOLOGY, Special Populations and Conditions, Renal Impairment**).

REVOLADE should be used with caution in patients with impaired renal function, and close monitoring performed, for example, by testing serum creatinine and/or urine analysis (see **DOSAGE AND ADMINISTRATION, Renal Impairment**).

There are limited data with the use of REVOLADE in patients with severe renal impairment (creatinine clearance < 30mL/min), therefore it is generally not recommended for use in these patients.

Reproduction

Eltrombopag did not affect female or male fertility in rats at doses 2 and 3 times respectively, the human clinical exposure based on AUC (see **TOXICOLOGY, Reproductive and Developmental Toxicity**).

Special Populations

Pregnant Women: REVOLADE has not been studied in pregnant women. REVOLADE should only be used during pregnancy if the expected benefit justifies the potential risk to the fetus.

Eltrombopag was studied in pregnant rats and rabbits, and caused a low incidence of cervical ribs (a fetal variation) along with reduced fetal body weight at doses that were maternally toxic (see **TOXICOLOGY, Reproductive and Developmental Toxicity**).

In patients with chronic hepatitis C virus infection, REVOLADE must be used in combination with pegylated interferon and ribavirin. Teratogenic and/or embryocidal effects have been demonstrated in all animal species exposed to ribavirin, while interferons have been shown to have abortifacient effects in animals. Refer to the prescribing information for pegylated interferon and ribavirin for full details.

Nursing Women: It is not known whether eltrombopag is excreted in human milk. Studies in animals have shown that eltrombopag is likely secreted into milk (see **TOXICOLOGY**); therefore a risk to the suckling child cannot be excluded. REVOLADE is not recommended for nursing mothers unless the expected benefit justifies the potential risk to the infant.

Pediatrics (<18 years of age): The safety and efficacy of REVOLADE have not been established in pediatric ITP patients younger than 1 year. Data are very limited for pediatric patients with chronic ITP between 1 and 2 years of age. Cataracts were observed in clinical trials with pediatric ITP patients and in juvenile rodents in an age-dependant manner with the youngest animals having the highest incidence. There are insufficient clinical data to determine whether pediatric patients are at an increased risk of REVOLADE-induced cataracts. For all patients, regardless of age, perform a baseline ocular examination prior to administration of REVOLADE, and regularly monitor for signs and symptoms of cataracts during therapy with REVOLADE.

The safety and efficacy of REVOLADE in pediatric patients with chronic HCV or SAA have not been established.

Geriatrics (>65 years of age): Clinical studies of REVOLADE did not include sufficient numbers of patients aged 65 and older to determine whether they respond differently from younger patients. In general, caution should be exercised in the administration and monitoring of REVOLADE in elderly patients, reflecting the greater frequency of decreased hepatic, renal, or cardiac function and of concomitant disease or other drug therapy.

Asian Patients: A reduced dose of REVOLADE is recommended in Asian patients with SAA and ITP but not in Asian patients with chronic HCV (see **DOSAGE AND ADMINISTRATION**).

Monitoring and Laboratory Tests

Complete Blood Counts (CBC): Monitor CBC, including platelet counts and peripheral blood smears, prior to initiation, throughout, and following discontinuation of therapy with REVOLADE. Prior to the initiation of REVOLADE, examine the peripheral blood differential to establish the extent of red and white blood cell abnormalities. Obtain CBC, including platelet counts and peripheral blood smears, weekly during the dose adjustment

phase of therapy with REVOLADE and then monthly following establishment of a stable dose of REVOLADE. The dose of REVOLADE may need to be modified based on platelet counts (see **DOSAGE AND ADMINISTRATION**). Examine the monthly peripheral blood smears and CBC for new or worsening morphologic abnormalities or cytopenia(s); if present, discontinue treatment with REVOLADE and consider a bone marrow biopsy, including staining for fibrosis. Obtain CBC, including platelet counts, weekly for 4 weeks following discontinuation of REVOLADE.

Liver Tests: Monitor serum liver tests (ALT, AST, and bilirubin) prior to initiation of REVOLADE, then every 2 weeks during the dose adjustment phase, and monthly following establishment of a stable dose. If bilirubin is elevated, perform fractionation. If abnormal levels are detected, repeat the tests within 3 to 5 days. If the abnormalities are confirmed, monitor serum liver tests weekly until the abnormalities resolve, stabilize, or return to baseline levels. Discontinue REVOLADE if important liver test abnormalities occur (see **DOSAGE AND ADMINISTRATION**).

Bone Marrow Examination: For ITP patients, consideration should be given to performing a bone marrow aspirate and biopsy over the course of the disease and treatment, particularly in patients over 60 years of age, those with systemic symptoms or abnormal signs such as increased peripheral blast cell. For SAA patients who have an insufficient response to immunosuppressive therapy, bone marrow examination with aspirations for cytogenetics is recommended prior to initiation of REVOLADE, at 3 months of treatment and 6 months thereafter. Discontinuation of REVOLADE should be considered if new cytogenetic abnormalities are observed.

Refer to the pegylated interferon and ribavirin Product Monographs for directions regarding dose reduction or discontinuation, as well as pregnancy testing requirements.

ADVERSE REACTIONS

Adverse Drug Reaction Overview

In the adult ITP clinical studies, hemorrhage was the most common serious adverse reaction and most hemorrhage reactions followed discontinuation of REVOLADE (eltrombopag). Other serious adverse reactions included liver test abnormalities and thromboembolic complications.

Based on an analysis of adult chronic ITP patients receiving REVOLADE in 3 controlled and 2 uncontrolled clinical studies, the median duration of exposure to REVOLADE was 379 days and patient year's exposure was 584 in this study population. Based on a final analysis of adult chronic ITP patients receiving REVOLADE in one uncontrolled extension study, the median daily dose was 51 mg and the median duration of exposure was 865 days. The safety of REVOLADE in pediatric patients (aged 1 to 17 years) with previously treated chronic ITP has been demonstrated in a pooled safety population of 157 patients, 107 treated with REVOLADE and 50 treated with placebo. The median exposure to REVOLADE in the randomized period was 91 days. The most common

adverse reactions observed with REVOLADE ($\geq 10\%$ and greater than placebo) were upper respiratory tract infection and nasopharyngitis. The number of patients with adverse events leading to discontinuation from study treatment was 1.9% versus 2.0%, REVOLADE versus placebo, respectively.

In the HCV clinical studies, the safety of REVOLADE in combination with interferon and ribavirin is supported by a clinical database of 1576 eltrombopag-treated adult patients enrolled in two pivotal, placebo-controlled, phase III studies and one supportive phase II study. The total patient years of exposure to eltrombopag in this study population was 674.06. The most commonly reported adverse events were fatigue, headache, myalgia, fever, and rigors. The Product Monographs for both pegylated interferon and ribavirin should be consulted for relevant safety information.

In the SAA pivotal phase II study (n=43), nausea, fatigue, cough, diarrhea, and headache were the most common adverse reactions reported. The most common serious adverse events reported were febrile neutropenia, sepsis and viral infection.

Clinical Trial Adverse Drug Reactions

Because clinical trials are conducted under very specific conditions the adverse reaction rates observed in the clinical trials may not reflect the rates observed in practice and should not be compared to the rates in the clinical trials of another drug. Adverse drug reaction information from clinical trials is useful for identifying drug-related adverse events and for approximating rates.

Adult Chronic Immune Thrombocytopenia (ITP)

The safety of REVOLADE has been demonstrated in two randomised, double-blind, placebo controlled studies in 211 adults with previously treated chronic ITP. Most adverse reactions associated with REVOLADE were mild to moderate in severity, early in onset and rarely treatment limiting. The most common adverse events were nausea, vomiting, diarrhea and headache. The drug-related adverse events occurring in $\geq 1\%$ of adult patients, and which were more common in the treatment group as compared to placebo in the Phase III, double-blind, placebo-controlled 6 week study, TRA100773B, and 6 month study, RAISE (TRA102537), are presented in Table 1 and Table 2, respectively.

The safety of REVOLADE over long-term dosing was evaluated in one single arm, open-label, extension study, EXTEND (TRA105325), in 302 adult patients with previously treated chronic ITP who were previously enrolled in an eltrombopag study. Overall, the safety data from this study reflect the known safety profile of REVOLADE. Drug-related adverse events occurring in $\geq 3\%$ of patients are presented in Table 3.

Table 1 Drug-Related Adverse Events $\geq 1\%$ in Adult ITP Patients over 6 weeks (Study TRA100773B)

Body System/Adverse Event	Treatment Group, n (%)	
	REVOLADE N=76	Placebo N=38
Cardiac disorders		
Sinus tachycardia	1(1)	0
Gastrointestinal		
Nausea	4(5)	0
Vomiting	2(3)	0
Abdominal distension	1(1)	0
Constipation	1(1)	0
Diarrhea	1(1)	0
Hemorrhoids	1(1)	0
Hepatobiliary disorders		
Hepatic function abnormal	1(1)	0
General disorders and administration site conditions		
Fatigue	2(3)	0
Malaise	1(1)	0
Investigations		
Protein total increased	3(4)	1(3)
ALT increased	2(3)	0
AST increased	2(3)	0
Metabolism and nutrition disorders		
Hypokalemia	1(1)	0
Musculoskeletal and connective tissue disorders		
Myalgia	3(4)	0
Arthralgia	1(1)	0
Bone pain	1(1)	0
Nervous system disorders		
Headache	4(5)	1(3)
Psychiatric disorders		
Sleep disorder	1(1)	0
Skin and subcutaneous tissue disorders		
Alopecia	1(1)	0
Night sweats	1(1)	0

Table 2 Drug-Related Adverse Events \geq 1% in Adult ITP Patients over 6 months (RAISE)

Body System/Adverse Event	Treatment Group, n (%)	
	REVOLADE N=135	Placebo N=61
Eye disorders		
Dry eye	2(1)	0
Gastrointestinal		
Nausea	6(4)	0
Constipation	3(2)	1(2)
Diarrhea	4(3)	0
Dry mouth	3(2)	0
Vomiting	2(1)	0
General Disorders and Administration Site Conditions		
Feeling hot	2(1)	0
Hepatobiliary disorders		
Hepatic function abnormal	2(1)	0
Investigations		
ALT increased	6(4)	2(3)
Hemoglobin increased	2(1)	0
Transaminases increased	2(1)	0
Musculoskeletal and connective tissue disorders		
Arthralgia	2(1)	0
Nervous system disorder		
Headache	15(11)	5(8)
Paraesthesia	3(2)	0
Skin and subcutaneous tissue disorders		
Hyperhidrosis	3(2)	0
Rash	2(1)	0

Clinical Trial Adverse Drug Reactions occurring in <1% of Adult ITP Patients

The drug-related adverse events occurring in <1% of REVOLADE treated patients (with a higher incidence compared to placebo) in the phase III, double-blind, placebo-controlled studies are presented below. The events are categorized by body system.

Blood and lymphatic system disorders: bone marrow reticulin increased

Cardiac Disorders: tachycardia

Ear and labyrinth disorders: vertigo

Eye Disorders: eye pain, lacrimation increased, lenticular opacities, retinal depigmentation hemorrhage, visual acuity reduced

Gastrointestinal: abdominal pain, abdominal pain upper, dyspepsia, feces discoloured, glossodynia, oral discomfort

General disorders and administration site conditions: asthenia, inflammation of wound, sensation of foreign body

Hepatobiliary disorders: hepatic lesions, hyperbilirubinemia

Infections and infestations: oral herpes, pharyngitis, sinusitis

Investigations: blood albumin increased, blood alkaline phosphatase increased, blood creatinine increased, hepatic enzyme increased

Metabolism and nutrition disorder: decreased appetite,

Neoplasms, benign, malignant and unspecified (incl. cysts and polyps):
Rectosigmoid cancer

Nervous system disorder: dysaesthesia, dysgeusia, hypoesthesia, somnolence

Skin and subcutaneous tissue disorders: cold sweat, pruritus, pruritus generalized, skin exfoliation, swelling face, urticaria

Respiratory, thoracic and mediastinal disorder: oropharyngeal blistering, pulmonary embolism, pulmonary infarction, sinus disorder

Vascular disorders: deep vein thrombosis, hot flush, thrombophlebitis superficial

In an additional clinical trial in patients with chronic ITP, one patient treated with REVOLADE (<1%) experienced drug-induced liver injury.

Bone Marrow Reticulin Formation:

Serial bone marrow biopsies were collected in a longitudinal 2-year bone marrow study with 162 previously treated adults with ITP. Results showed increases in bone marrow fibrosis grade from baseline in 34% of patients and the presence of collagen in 6 patients after 1 or 2 years of eltrombopag treatment. The shifts from baseline in patients with available biopsies are presented in Table 3. Collagen was not present in any patients at baseline. Four patients had post-treatment biopsies performed to assess the reversibility in fibrosis. Three of the 4 post-treatment biopsies showed a lower bone marrow fibrosis grade after discontinuation of treatment and 1 showed no change in bone marrow fibrosis grade.

Table 3 Shifts From Baseline To On-Treatment Assessment of European Consensus Scale

Time interval	n	Baseline grade	Maximum grade during time interval (N=162)				Total
			MF-0	MF-1	MF-2	MF-3	
1-year	127	MF-0	82 (65)	33 (26)	2 (2)	2 (2)	119 (94)
		MF-1	3 (2)	2 (2)	1 (<1)	0	6 (5)
		MF-2	0	0	0	0	0
		MF-3	0	0	0	0	0
		Missing	2 (2)	0	0	0	2 (2)
		Total	87 (69)	35 (28)	3 (2)	2 (2)	127 (100)
2-year	93	MF-0	79 (85)	9 (10)	0	0	88 (95)
		MF-1	2 (2)	1 (1)	0	0	3 (3)
		MF-2	0	0	0	0	0
		MF-3	0	0	0	0	0
		Missing	2 (2)	0	0	0	2 (2)
		Total	83 (89)	10 (11)	0	0	93 (100)

European Consensus scale, MF. MF-0: Scattered linear reticulin with no intersections corresponding to normal bone marrow; MF-1: Loose network of reticulin with many intersections, especially in perivascular areas; MF- 2: Diffuse and dense increase in reticulin with extensive intersections, occasionally only focal bundles of collagen and/or focal osteosclerosis; MF-3: Diffuse and dense increase in reticulin with extensive intersections with coarse bundles of collagen, often associated with significant osteosclerosis.

EXTEND (TRA105325)

Table 4 Drug-Related Adverse Events \geq 3% in Adult Chronic ITP Patients in EXTEND (Safety Population)

Preferred Term	Eltrombopag N=302
Any AE; n (%)	133 (44)
Headache	30 (10)
Alanine aminotransferase increased	16 (5)
Aspartate aminotransferase increased	15 (5)
Cataract	15 (5)
Fatigue	14 (5)
Blood bilirubin increased	12 (4)
Nausea	11 (4)
Hyperbilirubinaemia	9 (3)
Diarrhoea	8 (3)

The safety of REVOLADE was also assessed in all patients treated in 7 adult ITP clinical trials (N=763 REVOLADE-treated patients and 179 placebo-treated patients). Thromboembolic events were reported in 6% of REVOLADE-treated patients versus 0% of placebo-treated patients and thrombotic microangiopathy with acute renal failure was reported in <1% of REVOLADE-treated patients versus 0% of placebo-treated patients.

Pediatric Chronic Immune Thrombocytopenia (ITP)

PETIT2 (TRA115450)

The data described below reflect median exposure to REVOLADE of 91 days for 92 pediatric patients (aged 1 to 17 years) with chronic ITP in the Randomized Period of the randomized, placebo-controlled Phase III PETIT2 trial.

The overall incidence of adverse events (AEs) was higher in REVOLADE patients (81%) than in placebo patients (72%). The incidence of Grade 3 AEs was 13% versus 7% in the REVOLADE group versus the placebo group, respectively. Grade 3 events were predominantly hepatobiliary AEs in the REVOLADE group and bleeding AEs in the placebo group.

Table 5 presents the most common adverse reactions (experienced by greater than or equal to 3% of pediatric patients one year and older) in study PETIT2, with a higher incidence for REVOLADE versus placebo.

Table 5 Adverse Reactions ($\geq 3\%$) with a Higher Incidence for REVOLADE versus Placebo in Pediatric Patients 1 Year and Older with Chronic ITP in Study PETIT2 (Randomized Period Safety Population)

Body System/Adverse Reaction	Treatment Group, n (%)	
	REVOLADE N= 63	Placebo N= 29
Gastrointestinal		
Abdominal pain	6 (9.5)	0
Diarrhea	3 (4.8)	0
Toothache	3 (4.8)	0
General disorders and administration site conditions		
Pyrexia	4 (6.3)	1 (3.4)
Infections and Infestations		
Nasopharyngitis	11 (17.5)	2 (6.9)
Upper respiratory tract infection	7 (11.1)	1 (3.4)
Investigations		
AST increased	4 (6.3)	0
ALT increased	3 (4.8)	0
Metabolism and Nutrition Disorders		
Decreased appetite	3 (4.8)	0
Vitamin D deficiency	3 (4.8)	0
Respiratory, thoracic, and mediastinal disorders		
Cough	7 (11.1)	0
Oropharyngeal pain	3 (4.8)	0
Skin and subcutaneous tissue disorders		
Rash	3 (4.8)	0

Clinical Trial Adverse Reactions occurring in <3% of Pediatric Patients

The adverse reactions occurring in <3% of pediatric patients (with a higher incidence on REVOLADE compared to placebo) in study PETIT2 are presented below. The events are categorized by body system.

Blood and lymphatic system disorders: anemia

Ear and labyrinth disorders: motion sickness

Eye Disorders: retinal vascular disorder

Gastrointestinal disorders and administration site conditions: constipation, dyspepsia, lip hemorrhage, mouth hemorrhage, nausea

General disorders and administration site conditions: pain, asthenia, non-cardiac chest pain

Immune system disorders: allergy to chemicals

Infections and infestations: bronchitis, cellulitis, furuncle, influenza, lice infestation, meningitis aseptic, pharyngitis, pneumonia, pneumonia fungal, subcutaneous abscess, viral pharyngitis

Injury, poisoning and procedural complications: contusion, excoriation, joint injury, soft tissue injury

Investigations: activated partial thromboplastin time prolonged, blood alkaline phosphatase increased, alanine aminotransferase abnormal, aspartate aminotransferase abnormal, platelet count increased

Musculoskeletal and connective tissue disorders: back pain, groin pain, osteoporosis

Nervous system disorders: paresthesia, somnolence

Psychiatric disorders: bulimia nervosa

Skin and subcutaneous tissue disorders: dermatitis allergic, rash pruritic

Respiratory, thoracic and mediastinal disorders: bronchospasm, rhinorrhea, tonsillar hypertrophy

Chronic Hepatitis C Virus Infection

ENABLE 1 (N=716) and ENABLE 2 (N=805) were randomized, double-blind, placebo-controlled, multicentre studies to assess the efficacy and safety of REVOLADE in thrombocytopenic patients with HCV infection who were otherwise eligible to initiate antiviral therapy (see **CLINICAL TRIALS**).

In the HCV studies, the safety population consisted of all randomized patients who received double-blind study drug during Part 2 of ENABLE 1 (REVOLADE N=449, placebo N=232) and ENABLE 2 (REVOLADE N=506, placebo N=252).

Table 6 presents the most common adverse reactions, as determined by higher incidence in the eltrombopag arm and reported during the double-blind phase of ENABLE 1 and ENABLE 2 (experienced by ≥ 3 % of patients receiving REVOLADE, compared to placebo).

Table 6 Adverse Drug Reactions (Grades 2-4) $\geq 3\%$ in Two Placebo-Controlled Studies in Adults with Chronic Hepatitis C Virus (ENABLE 1 and ENABLE 2)

Body System/Adverse Event	Eltrombopag (N=955)	Placebo (N=484)
ANY EVENT	769 (81%)	392 (81%)
Blood and lymphatic system disorders		

Body System/Adverse Event	Eltrombopag (N=955)	Placebo (N=484)
Anaemia	236 (25%)	112 (23%)
Lymphopenia	26 (3%)	10 (2%)
General disorders and administration site conditions		
Fatigue	104 (11%)	45 (9%)
Pyrexia	71 (7%)	33 (7%)
Asthenia	54 (6%)	16 (3%)
Influenza like illness	52 (5%)	23 (5%)
Oedema peripheral	38 (4%)	5 (1%)
Irritability	25 (3%)	6 (1%)
Chills	24 (3%)	10 (2%)
Gastrointestinal disorders		
Diarrhea	60 (6%)	15 (3%)
Ascites	51 (5%)	14 (3%)
Abdominal pain	30 (3%)	11 (2%)
Vomiting	22 (2%)	8 (2%)
Abdominal pain upper	18 (2%)	6 (1%)
Investigations		
Blood bilirubin increased	58 (6%)	11 (2%)
White blood cell count decreased	44 (5%)	21 (4%)
Weight decreased	43 (5%)	14 (3%)
Haemoglobin decreased	41 (4%)	16 (3%)
Infections and infestations		
Urinary tract infection	34 (4%)	12 (2%)
Bronchitis	19 (2%)	6 (1%)
Pneumonia	15 (2%)	8 (2%)
Psychiatric disorders		
Insomnia	51 (5%)	22 (5%)
Depression	38 (4%)	18 (4%)
Nervous system disorders		
Headache	54 (6%)	24 (5%)
Hepatic encephalopathy	21 (2%)	1 (<1%)
Skin and subcutaneous tissues disorders		
Pruritus	26 (3%)	7 (1%)
Rash	26 (3%)	9 (2%)

Body System/Adverse Event	Eltrombopag (N=955)	Placebo (N=484)
Hepatobiliary disorders		
Hyperbilirubinaemia	68 (7%)	14 (3%)
Musculoskeletal and connective tissue disorders		
Arthralgia	27 (3%)	14 (3%)
Myalgia	26 (3%)	5 (1%)
Back pain	21 (2%)	4 (<1%)
Respiratory, thoracic and mediastinal disorders		
Cough	30 (3%)	7 (1%)
Dyspnea	21 (2%)	7 (1%)
Metabolism and nutrition disorders		
Decreased appetite	30 (3%)	15 (3%)
Neoplasms benign, malignant and unspecified (incl cysts and polyps)		
Hepatic neoplasm, malignant	34 (4%)	13 (3%)

In ENABLE 1 and ENABLE 2, progression of pre-existing baseline cataract(s) or new case of cataract were reported in 8 % of patients treated with REVOLADE and 5 % of patients treated with placebo during the double blind-phase.

The most common adverse events occurring during open-label treatment with REVOLADE in Part 1 of ENABLE 1 and 2 (see **CLINICAL TRIALS**) were headache, fatigue, nausea, diarrhea, and insomnia.

The safety of REVOLADE was also assessed in all patients treated with REVOLADE in the two controlled trials, including patients who initially received REVOLADE in the pre-antiviral treatment phase of the trial and were later randomized to the placebo arm (N=1520 REVOLADE-treated patients). Thromboembolic events (including portal vein thrombosis) was reported in 3% of REVOLADE-treated patients and 1% of placebo-treated patients and hepatic failure was reported in 1% of REVOLADE-treated patients and <1% of placebo-treated patients.

Severe Aplastic Anemia (SAA)

In the single-arm phase II study, 43 patients with severe aplastic anemia received REVOLADE with 11 patients (26%) treated for >6 months and 7 patients (16%) treated for >1 year. The most common adverse reactions ($\geq 20\%$) were nausea, fatigue, cough, diarrhea, and headache.

Table 7 Adverse Reactions (>5%) From the Single Arm Phase II Study in Adults with Severe Aplastic Anemia (Study ELT112523)

Adverse Reaction	REVOLADE (n = 43) (%)
Gastrointestinal disorders	
Nausea	33
Diarrhea	21
Abdominal pain	12
Abdominal discomfort	9
Gingival bleeding	9
Oral mucosal blistering	9
Oral pain	7
Vomiting	7
General disorders and administrative conditions	
Fatigue	28
Pyrexia	14
Asthenia	9
Chills	9
Edema peripheral	7
Respiratory, thoracic and mediastinal disorders	
Cough	23
Oropharyngeal pain	14
Rhinorrhea	12
Dyspnea exertional	9
Epistaxis	9
Hepatobiliary disorders	
Hyperbilirubinemia*	7
Nervous System Disorders	
Headache	21
Dizziness	14
Musculoskeletal and connective tissue disorders	
Pain in extremity	19
Arthralgia	12
Muscle spasms	12
Back pain	9
Investigations	
Transaminases increased	12
Liver function test abnormal	9
Alanine aminotransferase increased	7
Aspartate aminotransferase increased	7
Blood creatine phosphokinase increased	7
Skin and subcutaneous tissue disorders	
Petechiae	7
Rash	7
Eye disorders	
Dry eye	9
Psychiatric disorders	

Adverse Reaction	REVOLADE (n = 43) (%)
Insomnia	9
Anxiety	7
Depression	7
Metabolism and nutrition disorders	
Iron overload	7

*Hyperbilirubinemia includes preferred terms of blood bilirubin increased and hyperbilirubinemia.

The most common serious adverse events reported were febrile neutropenia, sepsis and viral infection.

Four patients (9%) discontinued treatment with REVOLADE due to cataract, abdominal discomfort, acute hepatitis B and sepsis.

Clinical Trial Adverse Drug Reactions occurring in ≤5% of SAA Patients

The drug-related adverse events occurring in ≤5% of REVOLADE treated severe aplastic anemia patients in the single arm phase II study in adults with severe aplastic anemia are presented below.

Blood and lymphatic system disorders: neutropenia, splenic infarction

Eye Disorders: cataract, ocular icterus, vision blurred, visual impairment, vitreous floaters

Gastrointestinal: constipation, abdominal distension, dysphagia, feces discolored, flatulence, gastrointestinal motility disorder, swollen tongue

General disorders and administration site conditions: malaise, pain

Hepatobiliary disorders: hyperbilirubinemia, jaundice

Investigations: blood bilirubin increased

Metabolism and nutrition disorder: decreased appetite, hypoglycemia, increased appetite

Musculoskeletal and connective tissue disorders: bone pain, myalgia

Nervous system disorder: dizziness postural, syncope

Psychiatric disorders: middle insomnia

Skin and subcutaneous tissue disorders: pruritus, urticaria, rash macular, skin lesion

Renal and urinary disorders: chromaturia

In the single-arm phase II study in SAA, patients had bone marrow aspirates evaluated for cytogenetic abnormalities. Eight patients had a new cytogenetic abnormality reported, including 5 patients who had changes in chromosome 7. Three patients were diagnosed with MDS following treatment with REVOLADE.

Post-Market Adverse Drug Reactions

The following adverse drug reactions have been reported during post-approval use of REVOLADE. These include spontaneous case reports as well as serious adverse events from registries, investigator sponsored studies, clinical pharmacology studies and exploratory studies in unapproved indications. Because they are reported voluntarily from a population of uncertain size, it is not possible to reliably estimate their frequency. Adverse drug reactions are listed according to system organ classes in MedDRA.

Skin and subcutaneous tissue disorders: Skin discolouration (In patients taking REVOLADE reversible skin discolouration including hyperpigmentation and skin yellowing was observed at REVOLADE doses as low as 50 mg per day; scleral discolouration was also reported in association with skin discoloration in some patients. Skin discolouration was particularly observed in patients taking REVOLADE for unapproved indications where doses higher than 100 mg per day were administered).

DRUG INTERACTIONS

Overview

Clinically significant drug interactions involving glucuronidation are not anticipated due to limited contribution of individual UGT enzymes in the glucuronidation of eltrombopag and potential co-medications. No clinically significant interactions are expected when REVOLADE (eltrombopag) and CYP450 substrates, inducers or inhibitors are co-administered (see **DETAILED PHARMACOLOGY, Pharmacokinetic Interactions**).

Drug-Drug Interactions

HMG CoA reductase inhibitors/OATP1B1 and BCRP substrates: *In vitro* studies demonstrated that eltrombopag is not a substrate for the organic anion transporter polypeptide, OATP1B1, but is an inhibitor of this transporter. *In vitro* studies also demonstrated that eltrombopag is a breast cancer resistance protein (BCRP) substrate and inhibitor. When REVOLADE and rosuvastatin were co-administered in a clinical drug interaction study (see **DETAILED PHARMACOLOGY, Pharmacokinetic Interactions**) there was increased plasma rosuvastatin exposure. Interactions are also expected with other HMG CoA reductase inhibitors, including pravastatin, simvastatin and lovastatin, however, clinically significant interactions are not expected between eltrombopag and atorvastatin or fluvastatin. When co-administered with REVOLADE, a reduced dose of statins should be considered and careful monitoring should be undertaken. In clinical trials with REVOLADE, a dose reduction of rosuvastatin by 50% was recommended for co-administration of rosuvastatin and REVOLADE. Concomitant

administration of REVOLADE and other OATP1B1 and BCRP substrates should be undertaken with caution.

Cyclosporine: Co-administration of REVOLADE with cyclosporine may cause a decrease in the concentration of REVOLADE (see **DETAILED PHARMACOLOGY, Pharmacokinetic Interactions**), though the exact mechanism is unknown. Therefore, caution should be used when co-administration of REVOLADE with cyclosporine takes place. Platelet count should be monitored at least weekly for 2 to 3 weeks in order to ensure appropriate medical management of the dose of REVOLADE when cyclosporine therapy is initiated or discontinued.

Lopinavir/ritonavir: Co-administration of REVOLADE with lopinavir/ritonavir (LPV/RTV) may cause a decrease in the concentration of eltrombopag (see **DETAILED PHARMACOLOGY, Pharmacokinetic Interactions**). Therefore, caution should be used when co-administration of REVOLADE with LPV/RTV takes place. Platelet count should be monitored at least weekly for 2 to 3 weeks in order to ensure appropriate medical management of the dose of REVOLADE when lopinavir/ritonavir therapy is initiated or discontinued.

Polyvalent cations (chelation): Eltrombopag chelates with polyvalent cations such as aluminium, calcium, iron, magnesium, selenium and zinc (see **DETAILED PHARMACOLOGY, Pharmacokinetic Interactions**). REVOLADE should be taken at least two hours before or four hours after any products such as antacids, dairy products, or mineral supplements containing polyvalent cations to avoid significant reduction in REVOLADE absorption (see **DOSAGE AND ADMINISTRATION**, and **DETAILED PHARMACOLOGY, Pharmacokinetic Interactions**).

Peginterferon alfa-2a/b and ribavirin therapy: Co-administration of peginterferon alfa 2a (PEGASYS[®]) or 2b (PEGETRON[®]) and ribavirin did not affect eltrombopag exposure in 2 randomized, double-blind, placebo-controlled trials with adult patients with chronic hepatitis C.

HCV protease inhibitors: A study in 56 healthy volunteers was conducted with eltrombopag and the HCV protease inhibitors boceprevir and telaprevir. Co-administration of eltrombopag with either telaprevir or boceprevir did not alter plasma concentrations of eltrombopag. Eltrombopag did not affect plasma concentrations of telaprevir. Eltrombopag did not affect the AUC or C_{max} of boceprevir, but reduced the C_τ by 32% (see **DETAILED PHARMACOLOGY, Pharmacokinetic Interactions**).

Drug-Food Interactions

Administration of a single 50 mg-dose of REVOLADE tablet with a standard high-calorie, high-fat breakfast that included dairy products reduced plasma eltrombopag concentrations. Food low in calcium (<50 mg calcium) did not significantly impact plasma eltrombopag exposure, regardless of calorie or fat content (see **DOSAGE AND ADMINISTRATION**, and **DETAILED PHARMACOLOGY, Pharmacokinetic Interactions**).

Drug-Laboratory Test Interactions

Interference with serological testing

Eltrombopag is highly colored and so has the potential to interfere with some laboratory tests. Serum discoloration and interference with total bilirubin and creatinine testing have been reported in patients taking REVOLADE. If the laboratory results and clinical observations are inconsistent, re-testing using another method may help in determining the validity of the result.

DOSAGE AND ADMINISTRATION

Chronic Immune Thrombocytopenia (ITP)

Dosing Considerations

REVOLADE (eltrombopag) treatment should be initiated and maintained by a physician who is experienced in the treatment of haematological diseases, who understands the benefits and risks associated with the treatment of ITP, and who is experienced in counselling patients for whom REVOLADE is indicated.

Prior to prescribing REVOLADE, physicians should:

- Ensure the eligibility of patients to meet the above criteria,
- Counsel each patient on the risks and benefits of REVOLADE, and
 - Ensure patients are able to swallow the REVOLADE tablets whole (see **All indications, Administration** below).

REVOLADE dosing regimens must be individualized based on the patient's platelet counts. The objective of treatment with REVOLADE should not be to normalise platelet counts but to maintain platelet counts above the level for hemorrhagic risk (>50 x 10⁹/L), and generally below 150 – 200 x 10⁹/L. Use the lowest effective dosing regimen to maintain platelet counts, as clinically indicated.

In most patients, measurable elevations in platelet counts take 1-2 weeks to occur (see CLINICAL TRIALS).

Recommended Dose and Dosage Adjustment

Initial Dose Regimen

Adults and Pediatric Patients Aged 6 years and above:

The recommended starting dose of REVOLADE is 50 mg once daily. For ITP patients of Asian ancestry (such as Chinese, Japanese, Taiwanese, Korean, or Thai) aged 6 and above, initiate REVOLADE at a reduced dose of 25 mg once daily (see **DOSAGE AND**

ADMINISTRATION, Asian Patients).

Pediatric Patients Aged 1 to <6 years:

The recommended starting dose of REVOLADE is 25 mg once daily.

Monitoring and Dose Adjustment

Adults and Pediatric Patients Aged 1 to <18 years:

If after 2 to 3 weeks of initial therapy, the platelet counts are below the clinically indicated levels (e.g. $50 \times 10^9/L$), the dose may be increased to a maximum of 75 mg once daily (see Table).

A dose reduction should be considered with platelet counts increasing to over $150 \times 10^9/L$. At platelet counts over $200 \times 10^9/L$ dose reduction is recommended (see Table 8).

REVOLADE should be interrupted if platelet counts increase to $>300 \times 10^9/L$. Once the platelet count is $<150 \times 10^9/L$; reinstate therapy at a reduced dose. If platelet counts remain at $>300 \times 10^9/L$ after 2 weeks of therapy of the lowest dose of REVOLADE, discontinue treatment (see Table 8).

Table 8 Dose Adjustments of REVOLADE in ITP patients

Platelet Count Result	Dose Adjustment or Response
<50 x 10 ⁹ /L following at least 2 weeks of REVOLADE	Increase daily dose by 25 mg to a maximum of 75 mg/day For patients taking 25 mg once every other day, increase dose to 25 mg once daily. For patients taking 12.5 mg once daily, increase the dose to 25 mg once daily before increasing the dose amount by 25 mg.
≥50 x 10 ⁹ /L to ≤200 x 10 ⁹ /L	Use lowest dose of REVOLADE and/or concomitant ITP treatment to maintain platelet counts that avoid or reduce bleeding.
>200 x 10 ⁹ /L to ≤300 x 10 ⁹ /L at any time	Decrease the daily dose by 25 mg. Wait 2 weeks to assess the effects of this and any subsequent dose adjustments For patients taking 25 mg once daily, consideration should be given to dosing at 12.5 mg once daily or alternatively a dose of 25 mg once every other day.
>300 x 10 ⁹ /L	Stop REVOLADE. Increase the frequency of platelet monitoring to twice weekly. Once the platelet count is <150 x 10 ⁹ /L, reinitiate therapy at a daily dose reduced by 25 mg. For patients taking 25 mg once daily, consideration should be given to reinitiating therapy at 12.5 mg once daily or alternatively a dose of 25 mg once every other day.
>300 x 10 ⁹ /L after 2 weeks of therapy at lowest dose of REVOLADE	Discontinue REVOLADE

The standard dose adjustment, whether decreased or increased, would be 25 mg once daily. However, in a few patients an alternate dosing of different tablet strengths on different days may be required.

After any REVOLADE dose adjustment, platelet counts should be monitored at least once weekly for 2 to 3 weeks. Wait for at least 2 weeks to see the effect of any dose increase on the patient's platelet response prior to considering another dose adjustment. **In patients with liver disease, wait at least 3 weeks before considering dose adjustment (see Hepatic Impairment, below).**

Monitor clinical hematology and liver tests regularly throughout therapy with REVOLADE and modify the dose of REVOLADE based on platelet counts as outlined in Table . During therapy with REVOLADE, assess complete blood counts (CBC), including platelet count and peripheral blood smears, weekly until a stable platelet count ($\geq 50 \times 10^9/L$ for at least 4 weeks) has been achieved. Obtain CBC including platelet count and peripheral blood smears, monthly thereafter.

REVOLADE can be administered in addition to other ITP medicinal products. Modify the dose regimen of concomitant ITP medicinal products, as medically appropriate, to avoid excessive increases in platelet counts during therapy with REVOLADE.

Discontinuation

Discontinue REVOLADE if the platelet count does not increase to a level sufficient to avoid clinically important bleeding after 4 weeks of therapy with REVOLADE at the maximum daily dose of 75 mg. Excessive platelet count responses, as outlined in Table , or important liver test abnormalities also necessitate discontinuation of REVOLADE (see **WARNINGS AND PRECAUTIONS**).

The reoccurrence of thrombocytopenia is possible upon discontinuation of treatment.

Chronic Hepatitis C-related Thrombocytopenia

Dosing Considerations

REVOLADE is given in combination with pegylated interferon and ribavirin. Reference should be made to the full Product Monographs for each respective co-administered medicinal product for comprehensive details of administration. The directions regarding the dosage, dose adjustment guidelines in the event of toxicity and other relevant safety information or contraindications for pegylated interferon and ribavirin should be followed.

REVOLADE should be used only in patients with chronic hepatitis C whose degree of thrombocytopenia prevents the initiation of interferon-based therapy and limits the ability to maintain interferon-based therapy.

Use the lowest dose of REVOLADE to achieve and maintain a platelet count necessary to initiate and maintain antiviral therapy. Dose adjustments are based

upon the patient’s platelet count response, see Table , below. Do not use REVOLADE to normalize platelet counts. In clinical studies, platelet counts generally increased within 1 week of starting REVOLADE.

The safety and efficacy of REVOLADE have not been established in combination with direct acting antiviral agents used in the treatment of chronic hepatitis C virus infection.

Recommended Dose and Dosage Adjustment

Adults (≥18 years of age):

REVOLADE should be initiated at a dose of 25 mg once daily. No dosage adjustment is necessary for HCV patients of Asian ancestry or patients with mild hepatic impairment.

The dose of REVOLADE should be adjusted in 25 mg increments every 2 weeks as necessary to achieve the target platelet count required to initiate antiviral therapy (see Table). Platelet counts should be monitored every week prior to starting antiviral therapy.

During antiviral therapy, the dose of REVOLADE should be adjusted as necessary to avoid dose reduction of peginterferon. Platelet counts should be monitored weekly during antiviral therapy until a stable platelet count is achieved. CBC’s, including platelet counts and peripheral blood smears should be obtained monthly thereafter.

Do not exceed a dose of 100 mg REVOLADE once daily.

For specific dosage instructions for peginterferon alfa or ribavirin, refer to their respective Product Monographs.

Table 9 Dose adjustments of REVOLADE in HCV patients during antiviral therapy

Platelet Count Result	Dose Adjustment or Response
<50 x 10 ⁹ /L following at least 2 weeks of therapy	Increase daily dose by 25 mg increments every 2 weeks as necessary to a maximum of 100 mg / day. For patients taking 25 mg once every other day, increase the dose to 25 mg once daily before increasing the dose amount by 25 mg. For patients taking 12.5 mg once daily, increase the dose to 25 mg once daily before increasing the dose amount by 25 mg.
≥50 x 10 ⁹ /L to ≤150 x 10 ⁹ /L	Maintain the lowest dose of REVOLADE to achieve these values so as to avoid dose reductions of peginterferon.
>150 x 10 ⁹ /L to ≤ 200 x 10 ⁹ /L	Decrease the daily dose by 25 mg. Wait 2 weeks to assess the effects of this and any subsequent dose adjustments.

	For patients taking 25 mg REVOLADE once daily, consideration should be given to dosing at 12.5 mg once daily or alternatively a dose of 25 mg once every other day.
>200 x 10 ⁹ /L	Stop REVOLADE; increase the frequency of platelet monitoring to twice weekly. Once the platelet count is < 150 x 10 ⁹ /L, reinstitute therapy at a lower daily dose. For patients taking 25 mg REVOLADE once daily, consideration should be given to reinitiating therapy at 12.5 mg once daily or alternatively a dose of 25 mg once every other day
>200 x 10 ⁹ /L after 2 weeks of therapy at lowest dose of REVOLADE	Discontinue REVOLADE

Discontinuation

When REVOLADE is given in combination with antiviral therapies reference should be made to the full Product Monograph of the respective co-administered medicinal products for comprehensive details of administration. The directions regarding the dose, dose adjustment guidelines in the event of toxicity and other relevant safety information or contraindications for the respective antiviral medicinal products should be followed.

In patients with HCV genotype 1/4/6, independent of the decision to continue interferon therapy, discontinuation of REVOLADE therapy should be considered in patients who do not achieve virological response at week 12. If HCV-RNA remains detectable after 24 weeks of treatment, REVOLADE therapy should be discontinued.

REVOLADE treatment should be terminated when antiviral therapy is discontinued. Excessive platelet count responses, as outlined in Table 9 or important liver test abnormalities may also necessitate discontinuation of REVOLADE (see **WARNINGS AND PRECAUTIONS**).

Severe Aplastic Anemia (SAA)

Dosing Considerations

Use the lowest dose of REVOLADE to achieve and maintain a hematologic response. Dose adjustments are based upon the platelet count. Do not use REVOLADE to normalize platelet counts (see **WARNINGS AND PRECAUTIONS, Thrombotic or thromboembolic complications**). Hematologic response requires dose titration, generally up to 150 mg, and may take up to 16 weeks after starting REVOLADE (See **CLINICAL TRIALS, Severe Aplastic Anemia**).

Recommended Dose and Dosage Adjustment

Adults (≥18 years of age):

REVOLADE should be initiated at a dose of 50 mg once daily. For SAA patients of Asian ancestry (such as Chinese, Japanese, Taiwanese, Korean, or Thai) or those with mild or moderate hepatic impairment (Child-Pugh Class A, B), REVOLADE should be initiated at a reduced dose of 25 mg once daily (See **DOSAGE AND ADMINISTRATION, Asian ancestry and Hepatic Impairment**).

The dose of REVOLADE should be initiated in 50 mg increments every 2 weeks as necessary to achieve the target platelet count $\geq 50 \times 10^9/L$. For patients with mild or moderate hepatic impairment or patients of Asian ancestry, increase the dose initially by 25 mg to achieve a 50 mg daily dose before considering further dose increases. Do not exceed a dose of 150 mg daily. Clinical hematology and liver tests should be monitored regularly throughout therapy with REVOLADE and the dosage regimen of REVOLADE should be modified based on platelet counts as outlined in Table 10.

Table 10 Dose adjustments of REVOLADE in SAA patients

Platelet Count Result	Dose Adjustment or Response
$<50 \times 10^9/L$ following at least 2 weeks of REVOLADE	Increase daily dose by 50 mg every two weeks as necessary to a maximum of 150 mg/day. For patients taking 25 mg once daily, increase the dose to 50 mg daily before increasing the dose amount by 50 mg.
$\geq 50 \times 10^9/L$ to $\leq 200 \times 10^9/L$	Maintain the lowest dose of REVOLADE to achieve these values.
$>200 \times 10^9/L$ to $\leq 300 \times 10^9/L$ at any time	Decrease the daily dose by 50 mg (or by 25 mg if these values are achieved with a 50 mg daily dose -i.e. in the Asian population or in patients with liver disease). Wait 2 weeks to assess the effects of this and any subsequent dose adjustments.
$>300 \times 10^9/L$	Stop REVOLADE for at least one week. Once the platelet count is $<150 \times 10^9/L$, reinitiate therapy at a dose reduced by 50 mg.
$>300 \times 10^9/L$ after 2 weeks of therapy at lowest dose of REVOLADE	Discontinue REVOLADE.

Tapering for Tri-lineage (white blood cells, red blood cells, and platelets) Responders: Once platelet count is $>50 \times 10^9/L$, hemoglobin is >100 g/L in the absence of red blood cell (RBC) transfusions, and absolute neutrophil count (ANC) is $>1 \times 10^9/L$ for more than

8 weeks, the dose of REVOLADE should be reduced by up to 50%. If counts stay stable after 8 weeks at the reduced dose, then REVOLADE should be discontinued and blood counts monitored as clinically indicated. If platelet counts drop to $<30 \times 10^9/L$, hemoglobin to $<90 \text{ g/L}$, or ANC to $<0.5 \times 10^9/L$, REVOLADE may be reinitiated at the previous dose.

Discontinuation

If no hematologic response has occurred after 16 weeks of therapy with REVOLADE, therapy should be discontinued. Discontinuation of REVOLADE should be considered if new cytogenetic abnormalities are observed (see **ADVERSE REACTIONS, Severe Aplastic Anemia, Clinical Trial Adverse Drug Reactions**). Excessive platelet count responses (as outlined in Table 10) or important liver test abnormalities also necessitate discontinuation of REVOLADE (see **WARNINGS AND PRECAUTIONS, Hepatic, Hepatotoxicity**).

All indications

Recommended Dose and Dosage Adjustment

Pediatrics (<18 years of age): The safety and efficacy of REVOLADE have not been established in pediatric ITP patients younger than 1 year. The safety and efficacy of REVOLADE in pediatric patients with chronic HCV or SAA have not been established.

Hepatic Impairment: REVOLADE is contraindicated in patients with severe hepatic impairment (Child-Pugh Class C) (See **CONTRAINDICATIONS**) and caution should be exercised when administering REVOLADE to patients with mild or moderate hepatic impairment, since exposure to eltrombopag increases with increasing degrees of hepatic dysfunction (see **ACTION AND CLINICAL PHARMACOLOGY, Special Populations and Conditions, Hepatic Impairment**).

The risk of thromboembolic events of the portal venous system has been found to be increased in patients with chronic liver disease treated with 75 mg REVOLADE once daily for two weeks in preparation for invasive procedures. REVOLADE therefore should not be used in ITP or SAA patients with hepatic impairment (Child-Pugh Class A and B) unless the expected benefit outweighs the identified risk of portal venous thrombosis (see **WARNINGS AND PRECAUTIONS**).

If the use of REVOLADE is deemed necessary in adult ITP or SAA patients with liver impairment (Child-Pugh Class A and B), the starting dose must be 25 mg once daily. Attempts to maintain platelet counts below $200 \times 10^9/L$ should be carried out in these patient populations. There are no data in pediatric patients with hepatic impairment.

After initiating REVOLADE or following any dose increase in ITP patients with liver impairment (Child-Pugh Class A and B), wait a minimum of 3 weeks before increasing the dose.

Thrombocytopenic patients with chronic HCV should initiate REVOLADE at the usual dose of 25 mg once daily (see **DETAILED PHARMACOLOGY, Pharmacokinetic Interactions**).

Renal Impairment: No dose adjustment is generally necessary in patients with renal impairment. REVOLADE should be used in patients having impaired renal function with caution and close monitoring, for example by testing serum creatinine and/or performing urine analysis (see **ACTION AND CLINICAL PHARMACOLOGY, Special Populations and Conditions, Renal Impairment**).

There are limited data with the use of REVOLADE in patients with severe renal impairment (creatinine clearance < 30mL/min), therefore it is generally not recommended for use in these patients (see **WARNINGS AND PRECAUTIONS, Renal, Renal Impairment**, and **ACTION AND CLINICAL PHARMACOLOGY, Special Populations and Conditions, Renal Impairment**).

Asian Patients: REVOLADE should be initiated at a reduced dose of 25 mg once daily is recommended for SAA and adult and pediatric (aged 6 to <18 years) ITP patients of Asian ancestry (such as Chinese, Japanese, Taiwanese, Thai or Korean) (see **ACTION AND CLINICAL PHARMACOLOGY, Special Populations and Conditions, Race**).

No dosage adjustment is necessary for chronic HCV patients of Asian ancestry. REVOLADE should be initiated at the recommended dose of 25 mg once daily (see **ACTION AND CLINICAL PHARMACOLOGY, Special Populations and Conditions**).

Patient platelet count should continue to be monitored and the standard criteria for further dose modification followed.

Elderly: There are limited data on the use of REVOLADE in patients aged 65 years and older and no clinical experience in patients aged over 85 years. In the clinical studies of REVOLADE, overall no clinically significant differences in the safety of REVOLADE were observed between patients aged at least 65 years and younger patients. Other reported clinical experience has not identified differences in responses between the elderly and younger patients, but greater sensitivity of some older individuals cannot be ruled out (see **ACTION AND CLINICAL PHARMACOLOGY, Special Populations and Conditions**).

Food Interactions: REVOLADE should be taken at least **two hours before or four hours** after antacids, dairy products, or mineral supplements, or any other products containing polyvalent cations (e.g. aluminium, calcium, iron, magnesium, selenium and zinc).

REVOLADE may be taken with food containing little (< 50 mg) or preferably no calcium (see **DETAILED PHARMACOLOGY, Pharmacokinetic Interactions**).

Missed Dose

If a dose of REVOLADE is missed, the patient should be advised to take it as soon as they remember, and then continue with the next dose at the regular interval. Two doses should not be taken at the same time to make up for a missed dose.

Administration

Patients should swallow the tablets whole, with some water. They should NOT crush tablets and then mix with food or liquids.

OVERDOSAGE

For management of suspected drug overdose, contact your regional Poison Control Centre.

Signs and Symptoms

In the clinical trials, there was one report of overdose where the patient ingested 5,000 mg of REVOLADE. Reported adverse events included mild rash, transient bradycardia, fatigue and elevated transaminases. Liver enzymes measured between Days 2 and 18 after ingestion peaked at a 1.6-fold ULN in AST, a 3.9-fold ULN in ALT, and a 2.4-fold ULN in total bilirubin. The patient's platelet count increased to a maximum of $929 \times 10^9/L$ at 13 days following the ingestion. After 2 months follow-up, all events resolved without sequelae.

Treatment

In the event of overdose, platelet counts may increase excessively and result in thrombotic/thromboembolic complications. In case of an overdose, oral administration of a metal cation-containing preparation, such as calcium, aluminium or magnesium preparation at the earliest possible opportunity, to chelate eltrombopag and thus limit absorption should be considered. Platelet counts should be closely monitored. Treatment with REVOLADE should be reinitiated in accordance with dosing and administration recommendations (see **DOSAGE AND ADMINISTRATION**).

Because eltrombopag is not significantly renally excreted and is highly bound to plasma proteins, hemodialysis would not be expected to be an effective method to enhance the elimination of eltrombopag.

ACTION AND CLINICAL PHARMACOLOGY

Mechanism of Action

Thrombopoietin (TPO) is the main cytokine involved in regulation of megakaryopoiesis and platelet production, and is the endogenous ligand for the thrombopoietin receptor (TPO-Receptor). REVOLADE (eltrombopag) interacts with the transmembrane domain of the human TPO-Receptor and initiates signaling cascades similar but not identical to that of endogenous TPO, inducing proliferation and differentiation of megakaryocytes from bone marrow progenitor cells.

Pharmacodynamics

Eltrombopag differs from TPO with respect to the effects on platelet aggregation. Unlike TPO, eltrombopag treatment of normal human platelets does not enhance adenosine diphosphate (ADP)-induced aggregation or induce P-selectin expression, nor does it antagonize platelet aggregation induced by ADP or collagen.

Pharmacokinetics

The pharmacokinetic (PK) parameters of eltrombopag after administration of an REVOLADE oral dose to adult patient with ITP are shown in Table 11.

Table 11 Steady-State Plasma Eltrombopag, Pharmacokinetic Parameters in Adults with Immune Thrombocytopenia

REVOLADE Dose (once daily)	N	C _{max} (µg/mL)	AUC _(0-τ) (µg.hr/mL)
50 mg	34	8.01 (6.73, 9.53)	108 (88, 134)
75 mg	26	12.7 (11.0, 14.5)	168 (143, 198)

Data presented as geometric mean (95 % CI). AUC_(0-τ) and C_{max} based on population PK post-hoc estimates.

Plasma eltrombopag concentration-time data collected in 590 patients with HCV enrolled in Phase III studies TPL103922/ENABLE 1 and TPL108390/ENABLE 2 were combined with data from patients with HCV enrolled in the Phase II study TPL102357 and healthy adults in a population PK analysis.

Plasma eltrombopag C_{max} and AUC_(0-τ) estimates for patients with HCV enrolled in the Phase III studies are presented for each dose studied in Table 12.

Table 12 Steady-State Plasma Eltrombopag Pharmacokinetic Parameters in Patients with Chronic HCV

REVOLADE Dose (once daily)	N	C_{max} (µg/mL)	AUC_(0-τ) (µg.h/mL)
25 mg	330	6.40 (5.97, 6.86)	118 (109, 128)
50 mg	119	9.08 (7.96, 10.35)	166 (143, 192)
75 mg	45	16.71 (14.26, 19.58)	301 (250, 363)
100 mg	96	19.19 (16.81, 21.91)	354 (304, 411)

Data presented as geometric mean (95%CI). AUC_(0-τ) and C_{max} based on population PK post-hoc estimates at the highest dose in the data for each patient.

Absorption: Eltrombopag is absorbed with a peak concentration occurring 2 to 6 hours after oral administration. Administration of REVOLADE concomitantly with antacids, dairy products, mineral supplements or other products containing polyvalent cations significantly reduces eltrombopag exposure (see **DRUG INTERACTIONS**). The absolute oral bioavailability of eltrombopag after administration to humans has not been established. Based on urinary excretion and metabolites eliminated in faeces, the oral absorption of drug-related material following administration of a single 75 mg eltrombopag solution dose was estimated to be at least 52%.

Distribution: Eltrombopag is highly bound to human plasma proteins (>99%). Eltrombopag is not a substrate for P-glycoprotein or OATP1B1.

Metabolism: Eltrombopag is primarily metabolized through cleavage, oxidation and conjugation with glucuronic acid, glutathione, or cysteine. In a human radiolabel study, eltrombopag accounted for approximately 64% of plasma radiocarbon AUC_(0-∞). Minor metabolites, each accounting for <10% of the plasma radioactivity, arising from glucuronidation and oxidation were also detected. Based on a human study with radiolabeled eltrombopag, it is estimated that approximately 20% of a dose is metabolized by oxidation. *In vitro* studies identified CYP1A2 and CYP2C8 as the isoenzymes responsible for oxidative metabolism, uridine diphosphoglucuronyl transferase UGT1A1 and UGT1A3 as the isozymes responsible for glucuronidation, and that bacteria in the lower gastrointestinal tract may be responsible for the cleavage pathways.

Excretion: Absorbed eltrombopag is extensively metabolized. The predominant route of eltrombopag excretion is via feces (59%) with 31% of the dose found in the urine as metabolites. Unchanged parent compound (eltrombopag olamine) is not detected in urine. Unchanged eltrombopag olamine excreted in feces accounts for approximately 20% of the dose. The plasma elimination half-life of eltrombopag is approximately 21-32 hours.

Special Populations and Conditions

Renal Impairment: The pharmacokinetics of eltrombopag have been studied after administration of REVOLADE to adult patients with renal impairment. Following administration of a single 50 mg-dose, the $AUC_{(0-\infty)}$ of eltrombopag was 32% to 36% lower in patients with mild to moderate renal impairment, and 60% lower in patients with severe renal impairment compared with healthy volunteers. There was substantial variability and significant overlap in exposures between patients with renal impairment and healthy volunteers. Unbound eltrombopag (active) concentrations for this highly protein bound medicinal product were not measured.

Pediatrics: The pharmacokinetics of eltrombopag have been evaluated in a population pharmacokinetic analysis which included 168 pediatric ITP patients dosed once daily in two studies, TRA108062 (PETIT) and TRA115450 (PETIT 2). Plasma eltrombopag apparent clearance following oral administration (CL/F) increased with increasing body weight. The effects of race and sex on plasma eltrombopag CL/F estimates were consistent between pediatric and adult patients. Asian pediatric ITP patients had approximately 43% higher plasma eltrombopag $AUC_{(0-\tau)}$ values (30% lower CL/F) as compared to non-Asian patients. Female pediatric ITP patients had approximately 25% higher plasma eltrombopag $AUC_{(0-\tau)}$ values (20% lower CL/F) as compared to male patients.

The pharmacokinetic parameters of eltrombopag in pediatric patients with ITP are shown in Table 13.

Table 13 Steady-State Plasma Eltrombopag Pharmacokinetic Parameters in Pediatric Patients with ITP (50 mg Once Daily Dosing Regimen)

Age	C_{max} ($\mu\text{g/mL}$)	$AUC_{(0-\tau)}$ ($\mu\text{g}\cdot\text{hr/mL}$)
12 to 17 years (n = 62)	6.80 (6.17, 7.50)	103 (91.1, 116)
6 to 11 years (n =68)	10.3 (9.42, 11.2)	153 (137, 170)
1 to 5 years (n = 38)	11.6 (10.4, 12.9)	162 (139, 187)

Data presented as geometric mean (95%CI). $AUC_{(0-\tau)}$ and C_{max} based on population PK post-hoc estimates for a 50 mg once daily dose.

Geriatrics: The age difference of eltrombopag pharmacokinetics was evaluated using population PK analysis in 28 healthy patients and 635 patients with HCV ranging from 19 to 74 years old. Based on model estimate, elderly (> 60 years) patients had approximately 36% higher plasma eltrombopag $AUC_{(0-\tau)}$ as compared to younger patients (see **DOSAGE AND ADMINISTRATION**).

Hepatic Impairment: The pharmacokinetics of eltrombopag have been studied after administration of REVOLADE to adult patients with liver cirrhosis (hepatic impairment). Following the administration of a single 50 mg dose, the $AUC_{(0-\infty)}$ of eltrombopag was

41% higher in patients with mild hepatic impairment and 80% to 93% higher in patient with moderate to severe hepatic impairment, compared with healthy volunteers. There was substantial variability and significant overlap in exposures between patients with hepatic impairment and healthy volunteers. Unbound eltrombopag (active) concentrations for this highly protein bound medicinal product were not measured.

The influence of hepatic impairment on the pharmacokinetics of eltrombopag following repeat administration was evaluated using a population pharmacokinetics analysis in 28 healthy adults and 714 patients with hepatic impairment (673 patients with HCV and 41 patients with chronic liver disease of other aetiology). Of the 714 patients, 642 were with mild hepatic impairment, 67 with moderate hepatic impairment, and 2 with severe hepatic impairment. Compared to healthy volunteers, patients with mild hepatic impairment had approximately 111% (95% CI: 45% to 283%) higher plasma eltrombopag $AUC_{(0-\tau)}$ values and patients with moderate hepatic impairment had approximately 183% (95% CI: 90% to 459%) higher plasma eltrombopag $AUC_{(0-\tau)}$ values.

The population PK/PD analysis of data collected in patients with chronic liver disease determined that the rate of platelet production was linearly related to plasma eltrombopag concentrations. In patients with chronic liver disease, the time to peak platelet count was approximately 3 weeks from the start of dosing.

Race: The influence of Asian ethnicity on the pharmacokinetics of eltrombopag was evaluated using a population pharmacokinetic analysis in 111 healthy adults (31 Asians) and 88 patients with ITP (18 Asians). Based on estimates from the population pharmacokinetic analysis, Asian (i.e. Japanese, Chinese, Taiwanese and Korean) ITP patients had approximately 87% higher plasma eltrombopag $AUC_{(0-\tau)}$ values as compared to non-Asian patients who were predominantly Caucasian, without adjustment for body weight differences (see **DOSAGE AND ADMINISTRATION**).

The influence of Asian ethnicity on the pharmacokinetics of eltrombopag was evaluated using a population PK analysis in 635 patients with HCV (145 East Asians and 69 Southeast Asians). Based on estimates from the population PK analysis, East Asian and Southeast Asian patients had similar pharmacokinetics of eltrombopag. On average, East/Southeast Asian patients had approximately 55% higher plasma eltrombopag $AUC_{(0-\tau)}$ values as compared to patients of other races who were predominantly Caucasian, without adjustment for body weight differences (see **DOSAGE AND ADMINISTRATION**).

Gender: The influence of gender on the pharmacokinetics of eltrombopag was evaluated using a population pharmacokinetics analysis in 111 healthy adults (14 females) and 88 patients with ITP (57 females). Based on estimates from the population pharmacokinetics analysis, female ITP patients had approximately 50% higher plasma eltrombopag $AUC_{(0-\tau)}$ as compared to male ITP patients, without adjustment for body weight differences.

The influence of gender on eltrombopag pharmacokinetics was evaluated using population pharmacokinetics analysis in 635 patients with HCV (260 females). Based on model estimate, female HCV patients had approximately 41 % higher plasma eltrombopag AUC_(0-∞) as compared to male patients.

STORAGE AND STABILITY

Store below 30°C, protect from freezing.

DOSAGE FORMS, COMPOSITION AND PACKAGING

REVOLADE (eltrombopag) tablets are available as round, biconvex, film-coated tablets available in blister packs of 14 or 28 as 12.5 mg-white, 25 mg-white, 50 mg-brown and 75mg-pink tablets. The 12.5 mg tablets are debossed with 'GS MZ1' and '12.5', 25 mg tablets are debossed with 'GS NX3' and '25', the 50 mg tablets are debossed with 'GS UFU' and '50' and the 75 mg tablets are debossed with 'GS FFS' and '75'.

Each tablet contains either 12.5 mg, 25 mg, 50 mg or 75 mg of eltrombopag as eltrombopag olamine. The tablet also contains the following nonmedicinal ingredients: magnesium stearate, mannitol, microcrystalline cellulose, povidone, sodium starch glycolate, hypromellose, macrogol and titanium dioxide. REVOLADE 12.5 mg and 25 mg tablets also contain polysorbate. REVOLADE 50 mg tablets also contain iron oxide yellow and iron oxide red. REVOLADE 75 mg tablets also contain iron oxide red and iron oxide black.

PART II: SCIENTIFIC INFORMATION

PHARMACEUTICAL INFORMATION

Drug Substance

Common name:	Eltrombopag olamine
Chemical name:	3'-{(2Z)-2-[1-(3,4-dimethyl-phenyl)-3-methyl-5-oxo-1,5-dihydro-4H-pyrazol-4-ylidene]hydrazino}-2'-hydroxy-3-biphenylcarboxylic acid-2-aminoethanol (1-2)
Molecular formula:	$C_{25} H_{22} N_4 O_4 \cdot 2 (C_2 H_7 N O)$,
Molecular mass	564.65 (eltrombopag olamine) 442.48 (eltrombopag)
Structural formula:	

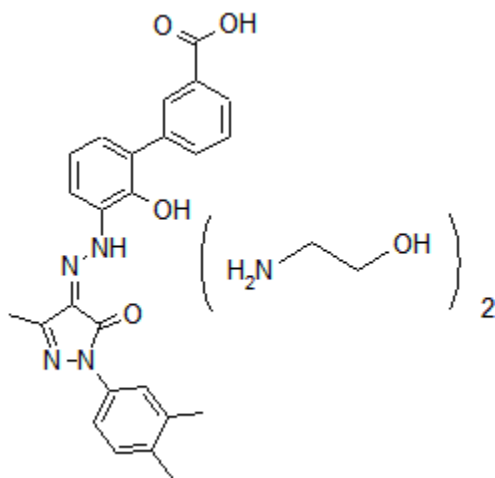

Physicochemical properties: Eltrombopag olamine is a red to brown solid, practically insoluble in aqueous buffer across a pH range of 1 to 7.4, and is sparingly soluble in water.

CLINICAL TRIALS

Chronic Immune Thrombocytopenia (ITP)

Study demographics and trial design

One Phase II, randomised, double blind, placebo-controlled study, TRA100773A, two Phase III, randomised, double blind, placebo-controlled studies RAISE (TRA102537) and TRA100773B and two open-label studies REPEAT (TRA108057) and EXTEND (TRA105325) evaluated the safety and efficacy of REVOLADE (eltrombopag) in previously treated adult patients diagnosed with chronic ITP for at least 6 months (see Table 14). Overall, eltrombopag was administered to a total of 446 patients, 280 patients for at least 6 months and 228 patients for at least 1 year.

Table 14 Summary of Trial Design and Patient Demographics for Clinical Trials in ITP

Study #	Trial design	Dosage, route of administration and duration	Study patients (N=number)	Mean age (Range)	Gender (%)
RAISE (TRA102537)	Phase III, double-blind, randomized, placebo-controlled.	Eltrombopag 50 mg or matching Placebo; Daily oral dosing for 6 months; Dose modification (to 25 mg or 75 mg) allowed based on individual platelet counts.	N= 197 Placebo: 62 Eltrombopag: 135	Placebo: 52.5 years (18 -77) Eltrombopag: 47 years (18-85)	Female: 69 Male: 31 Female: 69 Male: 31
TRA100773A	Phase II, double-blind, randomized, placebo-controlled.	Eltrombopag 30, 50, or 75 mg or matching Placebo; Daily oral dosing for 6 weeks.	Total N = 118 Placebo: 29 Eltrombopag: 30mg: 30 50mg: 30 75mg: 29	Placebo: 43 years (18-85) Eltrombopag: 30mg: 53 years (23-79) 50mg: 47 years (23-81) 75mg: 54 years (18-85)	Female: 55 Male: 45 Female: 53 Male: 47 Female: 70 Male: 30 Female: 71 Male: 29

Study #	Trial design	Dosage, route of administration and duration	Study patients (N=number)	Mean age (Range)	Gender (%)
TRA100773B	Phase III, double-blind, randomized, placebo-controlled.	Eltrombopag 50 mg or matching Placebo; Daily oral dosing for 6 weeks; Dose escalation to 75 mg allowed for non-responders.	N = 114 Placebo: 38 Eltrombopag: 76	Placebo: 51 years (21-79) Eltrombopag: 47 years (19-84)	Female: 71 Male: 29 Female: 57 Male: 43
REPEAT (TRA108057)	Single arm, open-label, intermittent dose.	Eltrombopag 50 mg; Daily oral dosing for up to 6 weeks, off-therapy for up to 4 weeks for 3 cycles; Dose escalation to 75 mg after Day 21 allowed.	N = 66 (Completed = 48)	Eltrombopag: 50 years (20-79)	Female: 68 Male: 32
EXTEND (TRA105325)	Single arm, open-label, extension study, previously enrolled in an eltrombopag study.	Eltrombopag 50 mg Daily oral dosing Dose modification (to 25 mg or 75 mg once daily) allowed based on individual platelet counts.	N = 299 (Received treatment = 298 Ongoing = 154 Withdrawn = 122)	Eltrombopag: 50 years (18-86)	Female: 198 Male: 101

Study Results

RAISE (TRA102537): In RAISE, the primary efficacy endpoint was the odds of achieving a platelet count $\geq 50 \times 10^9/L$ and $\leq 400 \times 10^9/L$, during the 6 month treatment period, for patients receiving eltrombopag relative to placebo. One hundred and ninety seven patients were randomized and were stratified based upon splenectomy status, use of ITP medication at baseline, and baseline platelet count. Patients received study medication for up to 6 months, during which time the dose of eltrombopag could be adjusted based on individual platelet counts. In addition, patients could have tapered off concomitant ITP medications and received rescue treatments as dictated by local standard of care.

A summary of baseline disease characteristics and key efficacy results is provided in Table 15. One week after treatment with study medication, platelet counts rose to between $50-400 \times 10^9/L$ in 37% of eltrombopag-treated patients compared to 7% of placebo-treated patients. The proportion of responders in the eltrombopag group was between 37% and 56% for all nominal on-therapy visits, with a minimum of 37% at Day 8 and a maximum of 56% at Day 36. In comparison, the proportion of responders in the placebo group was between 7% and 19% for all nominal on-therapy visits, with a

minimum of 7% at Day 8 and a maximum of 19% at Week 22 (see Figure 1). One week after discontinuation of treatment, more than 40% of patients treated with eltrombopag maintained platelet counts between $50\text{-}400 \times 10^9/\text{L}$, compared to placebo (15%). Two weeks after the end of treatment, the proportion of responders in the eltrombopag was similar to the placebo group.

The odds of achieving a platelet count between $50 \times 10^9/\text{L}$ and $400 \times 10^9/\text{L}$ during the 6 month treatment period were 8 times higher for eltrombopag treated patients than for placebo-treated patients.

Median platelet counts were maintained above $50 \times 10^9/\text{L}$ at all on-therapy visits starting at Day 15 in the eltrombopag group; in contrast, median platelet counts in the placebo group remained below $30 \times 10^9/\text{L}$ throughout the study.

At baseline, 77% of patients in the placebo group and 73% of patients in the eltrombopag group reported any bleeding (WHO Grades 1-4); clinically significant bleeding (WHO Grades 2-4) at baseline was reported in 28% and 22% of patients in the placebo and eltrombopag groups, respectively. The proportion of patients with any bleeding (Grades 1-4) and clinically significant bleeding (Grades 2-4) was reduced from baseline by approximately 50% throughout the 6 month treatment period in eltrombopag-treated patients. When compared to the placebo group, the odds of any bleeding (Grades 1-4) and the odds of clinically significant bleeding (Grades 2-4) were 76% and 65% lower in the eltrombopag-treated patients compared to the placebo-treated patients.

Significantly fewer eltrombopag-treated patients required rescue treatment compared to placebo-treated patients.

Figure 1 Summary of Responders (Platelet Counts $\geq 50 \times 10^9/L$ and $\leq 400 \times 10^9/L$). Day 8 to 4-weeks post treatment discontinuation, Primary Dataset (ITT Population)

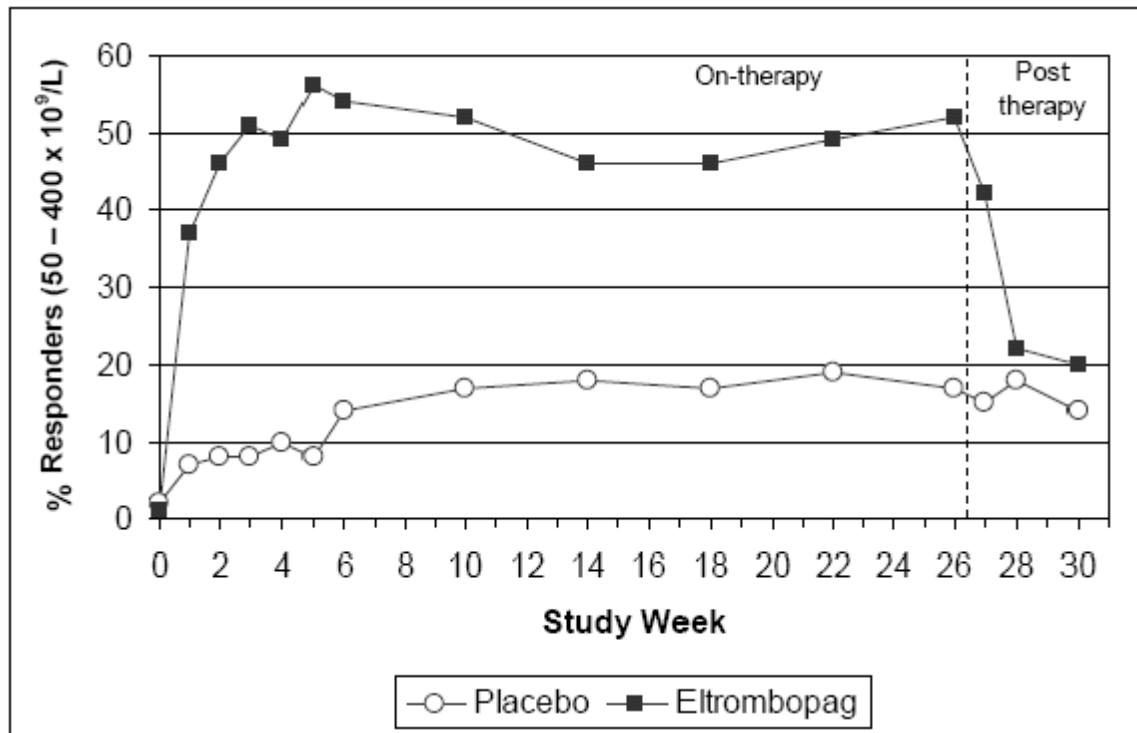

Eltrombopag therapy allowed significantly more patients to reduce or discontinue baseline ITP therapies compared to placebo.

Four placebo and 14 eltrombopag patients had at least 1 haemostatic challenge (defined as an invasive diagnostic or surgical procedure) during the study. However, fewer eltrombopag-treated patients (29%) required rescue treatment to manage their haemostatic challenge, compared to placebo-treated patients (50%).

In terms of improvements in health related quality of life, statistically significant improvements from baseline were observed in the eltrombopag group with fatigue, including severity and impact on thrombocytopenia-impacted daily activities and concerns (as measured by the vitality subscale of the SF36, the motivation and energy inventory, and the 6-item extract from the thrombocytopenia subscale of the FACIT-Th). Comparing the eltrombopag group to the placebo group, statistically significant improvements were observed with thrombocytopenia impacted activities and concerns specifically regarding motivation, energy and fatigue, as well as physical and emotional role and overall mental health. The odds of meaningful improvement in health related quality of life while on therapy was significantly greater among patients treated with eltrombopag than placebo.

In RAISE the response to eltrombopag relative to placebo was similar irrespective of ITP medication use, splenectomy status and baseline platelet count ($\leq 15 \times 10^9/L$, $>15 \times 10^9/L$) at randomization.

Table 15 Summary of Efficacy Results for the RAISE Study

	Eltrombopag N=135	Placebo (PBO) N=62
Baseline Disease Characteristics		
Patients with baseline platelet count $\leq 15 \times 10^9/L^a$, n (%)	67 (50)	30 (48)
Patients with baseline platelet count $> 15 \times 10^9/L$, n (%)	68 (50)	31 (50)
Proportion of patients that used ITP medication at randomization, n (%)	63 (47)	31 (50)
Splenectomised patients, n (%)	50 (37)	21 (34)
Non-Splenectomised patients, n (%)	85 (63)	41 (66)
Primary Endpoint		
Odds ratio (OR) for responding to treatment, Eltrombopag/Placebo ^{b, c}	8.2	
99% CI	3.59, 18.73	
p-value (two-sided vs. PBO)	<0.001	
Key Secondary Endpoints		
Analysis of Any Bleeding (WHO Grades 1-4)		
OR bleeding throughout 6 months, Eltrombopag/Placebo ^c	0.24	
95% CI	0.16, 0.38	
p-value (two-sided vs. PBO)	<0.001	
Patients with bleeding at any time during 6 months, n (%)	106 (79)	56 (93)
OR bleeding at any time in 6 months, Eltrombopag/Placebo ^d	0.21	
95% CI	0.06, 0.71	
p-value (two-sided vs. PBO)	0.012	
Analysis of Clinically Significant Bleeding (WHO Grades 2-4)		
OR bleeding throughout 6 months, Eltrombopag/Placebo ^c	0.35	
95% CI	0.19, 0.64	
p-value (two-sided, vs. PBO)	<0.001	
Patients with bleeding at any time during 6 months, n (%)	44 (33)	32 (53)
OR bleeding at any time in 6 months, Eltrombopag/Placebo ^d	0.30	
95% CI	0.14, 0.66	
p-value (two-sided vs. PBO)	0.002	
Concomitant Medication Reduction/Use of Rescue Medications		
Proportion of patients receiving rescue treatment, n (%) ^d	25 (19)	25 (40)
OR Eltrombopag/Placebo ^d	0.33	
95% CI	0.16, 0.64	
p-value (two-sided vs. PBO)	0.001	
Patients who reduced/discontinued ≥ 1 baseline ITP Medication, n (%) ^e	37 (59)	10 (32)
OR Eltrombopag/Placebo ^d	3.10	
95% CI	1.24, 7.75	
p-value (two-sided vs. PBO)	0.016	

- One patient in the placebo group has a missing baseline platelet count
- Responders defined as patients achieving platelet count between 50 to 400 x 10⁹/L,
- Repeated measures model for binary data adjusted for use of ITP medication at baseline, splenectomy status, baseline platelet count $\leq 15 \times 10^9/L$ and baseline dichotomized WHO Bleeding Scale for any bleeding and Clinically Significant Bleeding) using GEE methodology.
- Logistic regression model adjusted for use of ITP medication at baseline, splenectomy status, baseline platelet count $\leq 15 \times 10^9/L$ (and baseline dichotomized WHO Bleeding Scale for Any bleeding and Clinically Significant Bleeding).
- Denominator is number of patient taking an ITP medication at baseline.

TRA100773B: In TRA100773B, the primary efficacy endpoint was the proportion of responders, defined as patients who had an increase in platelet counts to $\geq 50 \times 10^9/L$ at Day 43 from a baseline $< 30 \times 10^9/L$; patients who withdrew prematurely due to a platelet count $> 200 \times 10^9/L$ were considered responders, those discontinued for any other reason were considered non-responders irrespective of platelet count.

A summary of baseline disease characteristics and key efficacy results is provided in Table 16. Fifty-nine percent of patients on eltrombopag responded, compared to 16% of patients on placebo. The odds of responding were 9 times higher for eltrombopag treated patients compared to placebo. At baseline, 61% of patients in the eltrombopag group and 66% of patients in the placebo group reported any bleeding (Grade 1-4). At Day 43, 39% of patients in the eltrombopag treatment group had bleeding compared with 60% in the placebo group. Analysis over the treatment period using a repeated measures model for binary data confirmed that a lower proportion of eltrombopag patients had bleeding (Grade 1-4) at any point in time over the course of their treatment (Day 8 up to Day 43) compared to patients in the placebo group (see Table 16). Two placebo and one eltrombopag patients had at least one haemostatic challenge during the study.

In TRA100773B the response to eltrombopag relative to placebo was similar irrespective of ITP medication use, splenectomy status and baseline platelet count ($\leq 15 \times 10^9/L$, $> 15 \times 10^9/L$) at randomization.

Table 16 Summary Efficacy Results for Study TRA100773B

	Eltrombopag N=76	Placebo N=38
Baseline Disease Characteristics		
Patients with baseline platelet count $\leq 15 \times 10^9/L$, n (%)	38 (50)	17 (45)
Patients with baseline platelet count $> 15 \times 10^9/L$, n (%)	38 (50)	21 (55)
Proportion of patients that used ITP medication at randomization, n (%)	32 (42)	17 (45)
Splenectomised patients, n (%)	31 (41)	14 (37)
Non-Splenectomised patients, n (%)	45 (59)	24 (63)
Primary Endpoint		
Proportion of patients who responded to treatment, n (%)	43(59) ^a	6 (16) ^a
Odds ratio (OR) for responding to treatment, Eltrombopag/Placebo ^b	9.61	
99% CI	(3.31, 27.86)	
p-value (two-sided vs. PBO)	<0.001	
Key Secondary Endpoint		
Analysis of Any Bleeding (WHO Grades 1-4)		
OR bleeding at any time during 6 weeks, Eltrombopag/Placebo	0.49	
95% CI	(0.26, 0.89)	
p-value (two-sided, vs. PBO)	0.021	

a One patient did not have a platelet count at 6 weeks

b Responder defined as patients who had an increase in platelet counts to $\geq 50 \times 10^9/L$ from baseline $< 30 \times 10^9/L$ after up to 6-weeks of dosing

REPEAT (TR4108057): REPEAT evaluated the efficacy, safety and consistency of response following repeated, intermittent, short-term dosing of eltrombopag over 3 cycles of therapy in adults with previously treated chronic ITP. A cycle was defined as an up to 6-week on-therapy period followed by an up to 4-week off-therapy period. The primary endpoint in REPEAT was the proportion of patients who achieved a platelet count $\geq 50 \times 10^9/L$ and at least 2x baseline in Cycle 2 or 3, given this response in Cycle 1.

Of the 52 patients who responded in Cycle 1, 33 (63%) achieved a platelet count of $\geq 50 \times 10^9/L$ and at least 2x baseline on Day 8 in Cycle 1; on Day 15, 37 (79%) of 47 evaluable patients achieved this level of response (see Table 17).

Table 17 Analysis of Responders in Cycle 1 and Cycle 2 or 3 (ITT Populations)

	Eltrombopag 50 mg (N=66)
Evaluable in Cycle 1, n	65*
Responders in Cycle 1, n (%)	52 (80)
Evaluable in Cycle 2 or 3, n	52
Responders in Cycle 1 and in Cycle 2 or 3, n (%)	45 (87)
Proportion	0.87
95 % CI for Proportion (Exact Methods)	(0.74, 0.94)

*1 patient was not evaluable for Cycle 1 due to a missing platelet count assessment at Day 43.

A reduction in any bleeding (WHO Grade 1-4) and clinically significant bleeding (WHO Grade 2-4) during the treatment phases was demonstrated in each cycle. At the baseline visit of Cycle 1, 50% and 19% of patients reported any bleeding and clinically significant bleeding, respectively. At the Day 43 Visit of Cycle 1, the proportion of patients bleeding was reduced; 12% and 0% of patients reported any bleeding and clinically significant bleeding, respectively. Similar results were found during the subsequent treatment cycles.

Eight patients successfully managed 10 haemostatic challenges without need for additional therapy to elevate platelet counts and without unexpected bleeding.

EXTEND (TR4105325): EXTEND evaluated the safety and efficacy of eltrombopag in patients (n=299) with chronic ITP who were previously enrolled in an eltrombopag trial. In this study, patients were permitted to modify their dose of study medication as well as decrease or eliminate concomitant ITP medications.

Two hundred and forty-nine patients completed ≥ 6 months of treatment, 210 completed ≥ 12 months of treatment, 138 patients completed ≥ 2 years of treatment, and 24 patients completed ≥ 3 years of treatment. The median follow up was 100 weeks. The majority of patients had baseline platelet counts of $< 30 \times 10^9/L$ (70%). The median daily dose of eltrombopag following at least 6 months (Day 182) of therapy was 50 mg (n = 252).

At baseline, 56% of patients had any bleeding (WHO Bleeding Grades 1–4) and 16% had clinically significant bleeding. The proportion of patients with any bleeding and clinically significant bleeding decreased from baseline by approximately 50% for the majority of assessments up to 1 year.

Sixty-five percent of patients who reduced a baseline medication permanently discontinued or had a sustained reduction of their baseline ITP medication and did not require any subsequent rescue treatment. Ninety-six percent of these patients maintained this discontinuation or reduction for at least 24 weeks. Fifty-four percent of patients completely discontinued at least one baseline ITP medication, and 49% of patients permanently discontinued all baseline ITP medications, without subsequent rescue treatment.

Fifty-six patients experienced at least one haemostatic challenge during the study. No patients experienced unexpected bleeding complications related to the procedure while on study.

Pediatric Chronic Immune Thrombocytopenia (ITP)

PETIT2 (TRAI15450)

Study demographics and trial design

The efficacy of eltrombopag in pediatric patients (aged 1 to 17 years) with chronic ITP for at least 12 months was evaluated in a Phase III double-blind, placebo-controlled study (Table 18). Overall, eltrombopag was administered to 63 pediatric patients with median exposure of 91 days during the Randomized Period. During the study, doses could be increased every 2 weeks, based on individual platelet counts, to a maximum of 75 mg once daily. The dose of eltrombopag was reduced if the platelet count exceeded $200 \times 10^9/L$ and interrupted if it exceeded $400 \times 10^9/L$.

Table 18 Summary of Trial Design and Patient Demographics for Study PETIT2 (TRA115450) in Pediatric ITP (Randomized Phase)

Study #	Trial design	Dosage, route of administration and duration	Study patients	Mean age (Range)	Gender (%)
PETIT2 (TRA115450)	Phase III, two-part double-blind, randomized, placebo-controlled and open-label.	<p>Cohorts 1 (12-17 years) and 2 (6-11 years) starting dose*: Eltrombopag 50 mg (if weighing \geq 27 kg) or 37.5 mg (if weighing < 27 kg) or matching Placebo; Daily oral tablet dosing</p> <p>Cohort 3 (1-5 years) starting dose[#]: 1.2 mg/kg or matching Placebo; Daily oral suspension dosing</p> <p>Part 1 (Randomized): 13 weeks</p> <p>Part 2 (Open-label): 24 weeks</p>	<p>Cohort 1 N=33</p> <p>Placebo: 10</p> <p>Eltrombopag: 23</p>	<p>Cohort 1</p> <p>Placebo: 14.3 years (12-17)</p> <p>Eltrombopag: 14.0 years (12-17)</p>	<p>Cohort 1</p> <p>Female: 30</p> <p>Male: 70</p> <p>Female: 39.1</p> <p>Male: 60.9</p>
			<p>Cohort 2 N=39</p> <p>Placebo: 13</p> <p>Eltrombopag: 26</p>	<p>Cohort 2</p> <p>Placebo: 8.7 years (6-11)</p> <p>Eltrombopag: 8.3 years (6-16)</p>	<p>Cohort 2</p> <p>Female: 53.8</p> <p>Male: 46.2</p> <p>Female: 50.0</p> <p>Male: 50.0</p>
			<p>Cohort 3 N=20</p> <p>Placebo: 6</p> <p>Eltrombopag: 14</p>	<p>Cohort 3</p> <p>Placebo: 4.7 years (4-5)</p> <p>Eltrombopag: 3.6 years (1-5)</p>	<p>Cohort 3</p> <p>Female: 66.7</p> <p>Male: 33.3</p> <p>Female: 57.1</p> <p>Male: 42.9</p>

* A reduced dose of 25 mg once daily was used for East Asian patients aged 6 to 17 years, regardless of weight.

The starting dose for East Asian patients aged 1 to 5 years was 0.8 mg/kg once daily administered as oral suspension.

Patients who were refractory or relapsed to at least one prior ITP therapy or unable to continue other ITP treatments for a medical reason, and had a platelet count < 30 x 10⁹/L (n = 92) were stratified by age and randomized (2:1) to eltrombopag (n = 63) or placebo (n = 29).

Across the three cohorts, the median age of the patients was 9 years; 48% were female; the majority were White (64%), and the remainder were primarily of Asian ancestry (defined as Japanese, East Asian or South East Asian). Approximately 63% of patients had a baseline platelet count less than or equal to 15 x 10⁹/L. Seventy-three percent in the group treated with REVOLADE and 90% in the group treated with placebo had received at least two prior ITP therapies (predominantly corticosteroids and immunoglobulins). Four (6%) patients in the group treated with eltrombopag had undergone splenectomy.

The primary efficacy endpoint was a sustained response, defined as the proportion of patients achieving platelet counts $\geq 50 \times 10^9/L$ for at least 6 out of 8 weeks (in the absence of rescue therapy), between Weeks 5 to 12 during the double-blind period.

Overall, a significantly greater proportion of eltrombopag patients (40 %) compared with placebo patients (3 %) achieved the primary endpoint ($p < 0.001$) which was similar across the three age cohorts (Table 19).

Table 19 Summary of Efficacy Results for the PETIT2 study

	Eltrombopag n/N (%)	Placebo n/N (%)
Overall	25/63 (40)*	1/29 (3)
Cohort 1	9/23 (39)	1/10 (10)
Cohort 2	11/26 (42)	0/13 (0)
Cohort 3	5/14 (36)	0/6 (0)

*P-value < 0.001 for eltrombopag versus placebo

A greater proportion of patients treated with eltrombopag (75 %) compared with placebo (21 %) had a platelet response (at least one platelet count $> 50 \times 10^9/L$ during the first 12 weeks of randomized treatment in absence of rescue therapy). The median of the maximum duration for which a platelet count $\geq 50 \times 10^9/L$ was continuously maintained during the first 12 weeks of the Randomized Period was 3.0 weeks (range: 0-12) for REVOLADE compared to 0 week (range: 0-8) for placebo.

Fewer eltrombopag patients required rescue treatment during the randomized period compared to placebo patients (19 % [12/63] vs. 24 % [7/29]).

Patients were permitted to reduce or discontinue baseline ITP therapy only during the open-label phase of the study and 53 % (8/15) of patients were able to reduce ($n = 1$) or discontinue ($n = 7$) baseline ITP therapy, mainly corticosteroids, without needing rescue therapy.

Chronic Hepatitis C-related Thrombocytopenia

Study demographics and trial design

The efficacy and safety of eltrombopag (REVOLADE) for the treatment of thrombocytopenia in patients with HCV infection were evaluated in two randomized, double-blind, placebo-controlled studies. ENABLE 1 utilized peginterferon alfa-2a (PEGASYS*) plus ribavirin for antiviral treatment and ENABLE 2 utilized peginterferon alfa-2b (PEGETRON*) plus ribavirin.

Table 20 Summary of Trial Design and Patient Demographics for Clinical Trials in HCV

Study #	Trial design	Dosage, route of administration and duration	Study patients (N=number)	Mean age (Range)	Gender N (%)
ENABLE 1 (TPL103922)	Phase III, double-blind, randomized, placebo-controlled	Pre-antiviral treatment phase: 25 mg once daily, increased in 25 mg increments, up to 100 mg	Pre-antiviral treatment phase: Eltrombopag N=715	Pre-antiviral treatment phase: Eltrombopag 51.8 yrs (19-76 yrs)	Pre-antiviral treatment phase: F: 269 (38%) M: 446 (62%)
		Antiviral treatment phase: Same dose as pre-treatment phase or placebo	Treatment phase: Placebo N=232 Eltrombopag N=450	Treatment phase: Placebo 51.4 yrs (23-72 yrs) Eltrombopag 52.1 yrs (19-76 yrs)	Treatment phase: Placebo F: 73 (31%) M: 159 (69%) Eltrombopag F: 186 (41%) M: 264 (59%)
ENABLE 2 (TPL108390)	Phase III, double-blind, randomized, placebo-controlled	Pre-antiviral treatment phase: 25 mg once daily, increased in 25 mg increments, up to 100 mg	Pre-antiviral treatment phase: Eltrombopag N=805	Pre-antiviral treatment phase: Eltrombopag 52.2 yrs (22-83 yrs)	Pre-antiviral treatment phase: F: 295 (37%) M: 510 (63%)
		Antiviral treatment phase: Same dose as pre-treatment phase or placebo	Treatment phase: Placebo N=253 Eltrombopag N=506	Treatment phase: Placebo 52.0 yrs (26-74 yrs) Eltrombopag 52.4 yrs (22-83 yrs)	Treatment phase: Placebo F: 93 (37%) M: 160 (63%) Eltrombopag F: 185 (37%) M: 321 (63%)

Study Results

ENABLE 1 and ENABLE 2 were global, multicenter, two-part studies that used a randomized withdrawal design. The studies were identical in design and differed only in the pegylated interferon/ribavirin used (ENABLE 1 utilized peginterferon alfa-2a (PEGASYS^{*}) plus ribavirin for antiviral treatment and ENABLE 2 utilized peginterferon alfa-2b (PEGETRON^{*}) plus ribavirin.

They consisted of two phases: an open-label (OL) pre-antiviral treatment phase (Part 1) and randomized, double-blind (DB), placebo-controlled antiviral treatment phase (Part2). In the pre-antiviral treatment phase (Part 1), all patients received open-label REVOLADE to increase the platelet count to $\geq 90 \times 10^9/L$ for ENABLE 1 and $\geq 100 \times 10^9/L$ for ENABLE 2. Median baseline platelet counts (approximately $60 \times 10^9/L$) were similar among all treatment groups.

In both studies, REVOLADE was administered at an initial dose of 25 mg once daily for 2 weeks. Dose escalations could occur every 2 weeks, in 25 mg increments up to a maximum of 100 mg eltrombopag daily, as needed to reach target platelet counts required to enter Part 2 of the study. The maximal time patients could receive open-label eltrombopag in Part 1 was 9 weeks.

Once eligible for Part 2, patients were randomized (2:1) to the same dose of eltrombopag received at the end of the pre-treatment phase (Part 1) or to placebo. REVOLADE or placebo was administered in combination with pegylated interferon/ribavirin antiviral treatment for up to 48 weeks (actual duration depending on HCV genotype). All patients in ENABLE 1 and ENABLE 2 were to attend post-treatment follow-up visits up to 24 weeks.

In both ENABLE 1 and ENABLE 2, patients with a platelet count of $< 75 \times 10^9/L$ were enrolled and stratified by platelet count ($< 50 \times 10^9/L$ and $\geq 50 \times 10^9/L$ to $< 75 \times 10^9/L$), screening HCV RNA ($< 800,000$ IU/mL and $\geq 800,000$ IU/mL), and HCV genotype (genotype 2/3, and genotype 1/4/6).

The primary efficacy endpoint for both studies was sustained virologic response (SVR) defined as the percentage of patients with non-detectable e HCV-RNA at 24 weeks after completion of the planned treatment period.

Baseline disease characteristics are described in Table 21 below.

Table 21 Baseline Disease Characteristics (Pooled Data, Intent-to-Treat Population)

	Eltrombopag (N=956)	Placebo (N=485)
HCV genotype, n (%)	n=953	n=484
1	612 (64)	309 (64)
2	67 (7)	50 (10)
3	228 (24)	101 (21)
4	41 (4)	22 (5)
6	5 (<1)	2 (<1)
HCV RNA, n (%)	n=954	n=483
<800,000 IU/mL	502 (53)	244 (51)
≥800, 000 IU/mL	452 (47)	239 (49)
Prior Antiviral Medications, n (%)	n=956	n=485
Naive	654 (68)	334 (69)
Experienced	302 (32)	151 (31)
Child-Pugh Classification, n (%)	n=953	n=485
A (score 5-6)	911 (96)	459 (95)
B (score 7-9)	42 (4)	26 (5)
ALT, n(%)	n=956	n=485
Normal	216 (23)	103(21)
Elevated	740(77)	382(79)
Baseline Platelet Count (Gi/L), n(%)	n=956	n=485
< 50	264 (28)	139(29)
≥50	692 (72)	346(71)
MELD Score n(%)	n=941	n=477
< 10	541 (57)	264 (55)
≥10	400 (43)	213 (45)
Baseline Albumin (g/L), n(%)	n=955	n=484
≤35	275 (29)	139(29)
>35	680 (71)	345(71)
FibroSURE Score; n (%)	n=842	n=426
0/1/2	83 (10)	42 (10)
3/4	759 (90)	384 (90)

Note: n represents patients with evaluable data.

In the pre-antiviral phase (Part 1) of ENABLE 1 and ENABLE 2, platelet counts began to rise within the first week of treatment with eltrombopag, and the median time to achieve the target platelet count $\geq 90 \times 10^9/L$ was approximately 2 weeks. Ninety-five percent of patients were able to initiate antiviral therapy, with over 80% of patients receiving 25 mg or 50 mg eltrombopag at randomization into the antiviral treatment phase (Part 2).

In both studies, a significantly greater proportion of patients treated with eltrombopag achieved SVR (see Table 22). A greater proportion of patients on eltrombopag achieved SVR regardless of baseline platelet count ($< 50 \times 10^9/L$ versus $\geq 50 \times 10^9/L$) compared to placebo. In patients with high viral loads ($> 800,000$), the SVR rate was reported at 18%

for eltrombopag versus 8% for placebo. Significantly more patients reached the antiviral milestones of early virologic response (EVR), complete EVR, end-of-treatment response (ETR), and SVR at 12 weeks when treated with eltrombopag.

Table 22 ENABLE 1 and ENABLE 2 Virologic and Platelet Response in Adults With Chronic Hepatitis C Virus

	ENABLE 1 ^a		ENABLE 2 ^b		Pooled Data	
Pre-antiviral Treatment Phase	N = 715		N = 805		N = 1520	
% Patients who achieved target platelet counts and initiated antiviral therapy ^c	95%		94%		95%	
Antiviral Treatment Phase	Eltrombopag N = 450 %	Placebo N = 232 %	Eltrombopag N = 506 %	Placebo N = 253 %	Eltrombopag N=956 %	Placebo N = 485 %
Overall SVR24^d	23	14	19	13	21	13
HCV Genotype 2,3	35	24	34	25	35	25
HCV Genotype 1,4,6	18	10	13	7	15	8
Platelet count <50 Gi/L	23	16	18	6	20	11
Platelet count ≥50 Gi/L	23	14	20	15	21	14
HCV RNA <800,000 IU/mL	28	20	20	17	24	18
HCV RNA ≥800,000 IU/mL	18	9	18	8	18	8

^a Eltrombopag given in combination with peginterferon alfa-2a (180 mcg once weekly for 48 weeks for genotypes 1 or 4; 24 weeks for genotype 2 or 3) plus ribavirin (800 to 1,200 mg daily in 2 divided doses orally).

^b Eltrombopag given in peginterferon alfa-2b (1.5 mcg/kg once weekly for 48 weeks for genotype 1; 24 weeks for genotype 2 or 3) plus ribavirin (800 to 1,400 mg orally).

^c Target platelet count was ≥90 x 10⁹/L for ENABLE 1 and ≥100 x 10⁹/L for ENABLE 2.

^d SVR: sustained viral response at 24 weeks following commencement of anti-viral therapy, p value < 0.05 for both ENABLE 1 and ENABLE 2

Results of secondary endpoint analyses showed the following: Significantly fewer patients treated with eltrombopag prematurely discontinued antiviral therapy compared to placebo (45% versus 60%, $P = 0.0001$). A greater proportion of patients on eltrombopag were reported to not require any antiviral dose reduction as compared to placebo (45% versus 27%), while the majority of patients treated with eltrombopag (76%) maintained a platelet count ≥50 x 10⁹/L, compared to 19% for placebo. A greater proportion of patients in the placebo group (20%) were seen to have had a platelet count nadir less than 25 x 10⁹/L during treatment, compared to patients treated with eltrombopag (3%).

Median platelet counts observed at the start of antiviral therapy were similar in both eltrombopag and placebo groups ($134 \times 10^9/L$ versus 135×10^9 , respectively) for pooled data in the HCV patient population. Four (4) weeks following the initiation of the double-blind treatment phase, platelet counts decreased to approximately $97 \times 10^9/L$ in the eltrombopag group and $48 \times 10^9/L$ in the placebo group. Median platelet counts remained near Week 4 values for the remainder of the double-blind treatment phase (Part 2).

Severe Aplastic Anemia (SAA)

REVOLADE was studied in a single-arm, single-center, phase II study in 43 patients with severe aplastic anemia who had an insufficient response to at least one course of antithymocyte globulin (rabbit or horse) plus cyclosporine and who had a platelet count $\leq 30 \times 10^9/L$.

REVOLADE was administered at an initial dose of 50 mg once daily for 2 weeks and increased by 25 mg over 2 week periods up to a maximum dose of 150 mg once daily. The primary endpoint was hematological response assessed after 12 or 16 weeks of REVOLADE treatment.

Hematological response was defined as meeting one or more of the following criteria: 1) platelet count increases to $20 \times 10^9/L$ above baseline, or stable platelet counts with transfusion independence for a minimum of 8 weeks; 2) hemoglobin increase by $>15g/L$, or a reduction in ≥ 4 units of RBC transfusions for 8 consecutive weeks; 3) absolute neutrophil count (ANC) increase of 100% or an ANC increase $>0.5 \times 10^9/L$.

REVOLADE was discontinued after 16 weeks if no hematologic response or transfusion independence was observed. Patients who responded continued therapy in an extension phase of the trial.

The treated population had median age of 45 years (range 17 to 77 years) and 56% were male. At baseline, the median platelet count was $20 \times 10^9/L$, hemoglobin was 84 g/L, ANC was $0.58 \times 10^9/L$ and absolute reticulocyte count was $24.3 \times 10^9/L$. Eighty-six percent of patients were RBC transfusion dependent and 91% were platelet transfusion dependent. The majority of patients (84%) had received at least 2 prior immunosuppressive therapies. Three patients had cytogenetic abnormalities at baseline.

Table 23 presents the primary efficacy results.

Table 23 Hematologic Response in Severe Aplastic Anemia

Outcome	REVOLADE N = 43
Response Rate, N (%)	17 (40)
95% CI (%)	(25, 56)

Bi- or tri-lineage responses were observed in 4/43 patients (9%) at the initial response assessment and in 8/43 patients (19%) at the last assessment. The longest platelet transfusion free period in responders ranged from 8 to 1,096 days with a median of 200 days. The longest RBC transfusion free period in responders ranged from 15 to 1,082 days with a median of 208 days. Four patients who tapered off treatment with REVOLADE due to a tri-lineage response maintained a response for a median follow up period of 8 months (7.2 to 10.6 months).

DETAILED PHARMACOLOGY

REVOLADE (eltrombopag) does not stimulate platelet production in mice, rats or dogs because of unique TPO receptor specificity and therefore data from these animals do not fully model potential adverse effects related to the pharmacology of eltrombopag in humans.

Pharmacokinetic Interactions

Based on a human study with radiolabelled eltrombopag, glucuronidation plays a minor role in the metabolism of eltrombopag. Human liver microsome studies identified UGT1A1 and UGT1A3 as the enzymes responsible for eltrombopag glucuronidation. Eltrombopag was an inhibitor of a number of UGT enzymes *in vitro*. Clinically significant drug interactions involving glucuronidation are not anticipated due to limited contribution of individual UGT enzymes in the glucuronidation of eltrombopag and potential co-mediations.

Based on a human study with radiolabelled eltrombopag, approximately 21% of an eltrombopag dose could undergo oxidative metabolism. Human liver microsome studies identified CYP1A2 and CYP2C8 as the enzymes responsible for eltrombopag oxidation. In studies utilizing human liver microsomes, eltrombopag (up to 100 μM) showed no *in vitro* inhibition of the CYP450 enzymes 1A2, 2A6, 2C19, 2D6, 2E1, 3A4/5, and 4A9/11, and was an inhibitor of CYP2C8 and CYP2C9 as measured using paclitaxel and diclofenac as the probe substrates, with IC_{50} values of 24.8 μM (11 $\mu\text{g}/\text{mL}$) and 20.2 μM (8.9 $\mu\text{g}/\text{mL}$), respectively. Administration of eltrombopag 75 mg once daily for 7 days to 24 healthy male patients did not inhibit or induce the metabolism of probe substrates for 1A2 (caffeine), 2C19 (omeprazole), 2C9 (flurbiprofen), or 3A4 (midazolam) in humans. No clinically significant interactions are expected when eltrombopag and CYP450 substrates, inducers or inhibitors are co-administered.

In vitro studies demonstrate that eltrombopag is an inhibitor of the OATP1B1 transporter, with an IC_{50} value of 2.7 μM (1.2 $\mu\text{g}/\text{mL}$) and an inhibitor of the BCRP transporter, with an IC_{50} value of 2.7 μM (1.2 $\mu\text{g}/\text{mL}$). Administration of eltrombopag 75 mg once daily for 5 days with a single 10 mg dose of the OATP1B1 and BCRP substrate rosuvastatin to 39 healthy adult patients increased plasma rosuvastatin C_{max} 103% (90% CI: 82%, 126%) and $\text{AUC}_{(0-\infty)}$ 55% (90% CI: 42%, 69%) (see **DRUG INTERACTIONS, Drug-Drug Interactions**).

Administration of a single dose of eltrombopag 50 mg tablet with 200 mg cyclosporine decreased the C_{max} and the $AUC_{(0-\infty)}$ of eltrombopag by 25% (90% CI: 15%, 35%) and 18% (90% CI: 8%, 28%), respectively. The co-administration of 600 mg cyclosporine decreased the C_{max} and the $AUC_{(0-\infty)}$ of eltrombopag by 39% (90% CI: 30%, 47%) and 24% (90% CI: 14%, 32%), respectively. The exact mechanism is unknown.

Co-administration of eltrombopag with lopinavir/ritonavir (LPV/RTV) may cause a decrease in the concentration of eltrombopag. A study in 40 healthy volunteers showed that the co-administration of single dose eltrombopag 100 mg with repeat dose LPV/RTV 400/100 mg twice daily resulted in a reduction in eltrombopag plasma $AUC_{(0-\infty)}$ by 17% (90% CI: 6.6%, 26.6%) (see **DRUG INTERACTIONS, Drug-Drug Interactions**).

Co-administration of eltrombopag with the HCV protease inhibitor boceprevir did not have an effect on the concentration of eltrombopag. A study in 28 healthy volunteers showed that the co-administration of single dose eltrombopag 200 mg with repeat dose boceprevir 750 mg three times daily reduced the boceprevir plasma $AUC_{(0-\infty)}$ by 4% (90% CI: -14.7%, 8.5%). Co-administration of single dose eltrombopag 200 mg with repeat dose boceprevir 800 mg three times daily reduced the boceprevir plasma $AUC_{(0-\infty)}$ by 4% (90% CI: 0.8%, 7.9%) and the $C\tau$ by 32% (90% CI -41.7%, -21.4%) (see **DRUG INTERACTIONS, Drug-Drug Interactions**).

Co-administration of eltrombopag with the HCV protease inhibitor telaprevir did not have an effect on the concentration of eltrombopag. A study in 28 healthy volunteers showed that the co-administration of single dose eltrombopag 200 mg with repeat dose telaprevir 750 mg three times daily reduced the eltrombopag plasma $AUC_{(0-\infty)}$ by 6% (90% CI: -14.7%, 3.5%). Co-administration of single dose eltrombopag 200 mg with repeat dose telaprevir 750 mg three times daily reduced the telaprevir plasma $AUC_{(0-\infty)}$ by 2% (90% CI: -6.1%, 2.5%) (see **DRUG INTERACTIONS, Drug-Drug Interactions**).

Administration of a single dose of eltrombopag 75 mg with a polyvalent cation-containing antacid (1,524 mg aluminium hydroxide and 1,425 mg magnesium carbonate) decreased plasma eltrombopag $AUC_{(0-\infty)}$ by 70% (90% CI: 64%, 76%) and C_{max} by 70% (90% CI: 62%, 76%) (see **DOSAGE AND ADMINISTRATION, and DRUG INTERACTIONS, Drug-Drug Interactions**).

Administration of a single 50 mg dose of eltrombopag with a standard high-calorie, high-fat breakfast that included dairy products reduced plasma eltrombopag $AUC_{(0-\infty)}$ by 59% (90% CI: 54%, 64%) and C_{max} by 65% (90% CI: 59%, 70%). Whereas, low-calcium food (<50 mg calcium) including fruit, lean ham, beef and unfortified (no added calcium, magnesium, iron) fruit juice, unfortified soy milk, and unfortified grain did not significantly impact plasma eltrombopag exposure, regardless of calorie and fat content (see **DOSAGE AND ADMINISTRATION, and DRUG INTERACTIONS, Drug-Food Interactions**).

TOXICOLOGY

REVOLADE (eltrombopag) does not stimulate platelet production in mice, rats, or dogs because of unique TPO receptor specificity. These animal species do not therefore model any potential on-target adverse effects related to the pharmacology of eltrombopag in the general toxicology, reproductive toxicology, and carcinogenicity studies. In the absence of nonclinical models to study potential on-target effects, it is acknowledged that the toxicology program lacks the ability to fully evaluate the safety of eltrombopag through study of the exaggerated pharmacology. The toxicology evaluation was therefore limited to identify potential off-target effects.

Repeat Dose Toxicity

The toxicity of repeated oral doses of eltrombopag has been assessed in mice, rats, rabbits and dogs in studies of up to 13, 28, 1 and 52 weeks, respectively. Eltrombopag was well tolerated with no adverse treatment-related clinical signs, effects on food consumption or body weight, or mortality for up to 13 weeks in mice at doses ≤ 100 mg/kg/day (652 $\mu\text{g}\cdot\text{h}/\text{mL}$), 28 weeks or 2 years in rats at doses ≤ 30 or 40 mg/kg/day (661 or 677 $\mu\text{g}\cdot\text{h}/\text{mL}$, respectively), 1 week in rabbits at doses ≤ 150 mg/kg/day (59 $\mu\text{g}\cdot\text{h}/\text{mL}$), and 52 weeks in dogs at doses ≤ 30 mg/kg/day (418 $\mu\text{g}\cdot\text{h}/\text{mL}$). Systemic exposures at these dose levels were 4.5-fold the maximum proposed human exposure in mice and rats, 0.4-fold in rabbits and 2.9-fold in dogs.

Treatment-related cataracts were detected in rodents and were dose and time-dependent. At ≥ 6 times the human clinical exposure based on AUC in ITP patients at 75 mg/day and 3 times the human clinical exposure based on AUC in HCV patients at 100 mg/day, cataracts were observed in mice after 6 weeks and rats after 28 weeks of dosing. At ≥ 4 times the human clinical exposure based on AUC in ITP patients at 75 mg/day and 2 times the human clinical exposure based on AUC in HCV patients at 100 mg/day, cataracts were observed in mice after 13 weeks and in rats after 39 weeks of dosing.

Cataracts have not been observed in dogs after 52 weeks of dosing at 2 times the human clinical exposure in ITP or pediatric ITP patients and equivalent to the human clinical exposure in HCV patients based on AUC.

Renal tubular toxicity was observed in studies of up to 14 days duration in mice and rats at exposures that were generally associated with morbidity and mortality. Tubular toxicity was also observed in a 2 year oral carcinogenicity study in mice at doses of 25, 75 and 150 mg/kg/day. Effects were less severe at lower doses and were characterized by a spectrum of regenerative changes. The exposure at the lowest dose was 1.2 times and 0.8 times the human clinical exposure based on AUC in ITP and pediatric ITP patients, respectively, at 75 mg/day and 0.6 times the human clinical exposure based on AUC in HCV patients at 100 mg/day.

Renal effects were not observed in rats after 28 weeks or in dogs after 52 weeks at

exposures 4 and 2 times respectively, the human clinical exposure in ITP patients, 3 and 2 times, respectively, the human clinical exposure in pediatric ITP patients, and 2 times and equivalent to the human clinical exposure in HCV patients, based on AUC.

Hepatocyte degeneration and/or necrosis, often accompanied by increased serum liver enzymes, was observed in mice, rats and dogs at doses that were associated with morbidity and mortality or were poorly tolerated. No hepatic effects were observed after chronic dosing in rats (28 weeks) or dogs (52 weeks) at exposures up to 4 or 2 times, respectively, the human clinical exposure in ITP patients, and 3 and 2 times, respectively, the human clinical exposure in pediatric ITP patients at 75 mg/day, and 2 times or equivalent to the human clinical exposure in HCV patients at 100 mg/day, based on AUC.

Carcinogenicity

Eltrombopag was not carcinogenic in mice at doses up to 75 mg/kg/day or in rats at doses up to 40 mg/kg/day (exposures up to 4 times and 2 times the human clinical exposure based on AUC in ITP and pediatric ITP patients, respectively, and 2 times the human clinical exposure based on AUC in HCV patients at 100 mg/day).

Genotoxicity

Eltrombopag was not mutagenic or clastogenic in a bacterial mutation assay or in two *in vivo* assays in rats (micronucleus and unscheduled DNA synthesis, 10 times and 8 times the human clinical exposure based on C_{max} in ITP and pediatric ITP patients, respectively, at 75 mg/day and 7 times the human clinical exposure in HCV patients at 100 mg/day). In the *in vitro* mouse lymphoma assay, eltrombopag was marginally positive (<3 fold increase in mutation frequency). These *in vitro* and *in vivo* findings suggest that eltrombopag does not pose a genotoxic risk to humans.

Phototoxicity

In vitro studies with eltrombopag suggest a potential photosafety risk; however, in rodents there was no evidence of cutaneous phototoxicity (10 times and 7 times the human clinical exposure in ITP and pediatric ITP patients, respectively, and 5 times the human clinical exposure in HCV patients, based on AUC) or ocular phototoxicity (≥ 6 times and ≥ 4 times the human clinical exposure in ITP and pediatric ITP patients, respectively, and ≥ 3 times the human clinical exposure in HCV patients, based on AUC). Furthermore, a clinical pharmacology study in 36 patients showed no evidence that photosensitivity was increased following administration of eltrombopag 75 mg. This was measured by delayed phototoxic index. Nevertheless, a potential risk of photoallergy cannot be ruled out since no specific preclinical study could be performed.

Reproductive and Developmental Toxicity

REVOLADE did not affect female fertility, early embryonic development or embryofetal development in rats at doses up to 20 mg/kg/day (2 times and approximately equivalent to the human clinical exposure in ITP and pediatric ITP patients, respectively, at 75

mg/day and equivalent to the human clinical exposure in HCV patients at 100 mg/day, based on AUC). Also there was no effect on embryofetal development in rabbits at doses up to 150 mg/kg/day, the highest dose tested (0.3 to 0.5 times the human clinical exposure in ITP, pediatric ITP, and HCV patients based on AUC). However, at a maternally toxic dose of 60 mg/kg/day (6 times and 4 times the human clinical exposure in ITP and pediatric ITP patients, respectively, and 3 times the human clinical exposure in HCV patients, based on AUC) in rats, REVOLADE treatment was associated with embryo lethality (increased pre and post implantation loss), reduced fetal body weight and gravid uterine weight in the female fertility study and a low incidence of cervical ribs and reduced fetal body weight in the embryofetal development study.

Special Populations and Conditions: REVOLADE did not affect male fertility in rats at doses up to 40 mg/kg/day, the highest dose tested (3 times the human clinical exposure in ITP and pediatric ITP patients and 2 times the human clinical exposure in HCV patients, based on AUC). In the pre- and post-natal development study in rats, there were no undesirable effects on pregnancy, parturition or lactation of F₀ female rats at maternally non-toxic doses (10 and 20 mg/kg/day) and no effects on the growth, development, neurobehavioral or reproductive function of the offspring (F₁). REVOLADE was detected in the plasma of all F₁ rat pups for the entire 22 hour sampling period following administration of medicinal product to the F₀ dams, suggesting that rat pup exposure to REVOLADE was likely via lactation.

Juvenile Toxicity: Age-dependent development of hepatic excretory pathways and reduced hepatic clearance led to higher exposures of eltrombopag and poor tolerability in very young rats. In a juvenile rat study using pups treated from days 4-31 postpartum, all pups at 60 mg/kg/day were either found dead or euthanized by day 14. Six pups were found dead or euthanized early at 30 mg/kg/day, a dose that is 9 times the maximum clinical exposure in pediatric ITP patients at 75 mg/day, based on AUC. In juvenile rats dosed from day 32-63 postpartum, mortality was not observed.

In definitive juvenile toxicity studies in rats, eltrombopag was not associated with adverse effects at doses up to 15 mg/kg/day in pups dosed from Days 4 to 31 pp and 40 mg/kg/day in pups dosed from Days 32 to 63 pp. In rat pups dosed from Days 4 to 31 pp, a dose of 15 mg/kg/day (exposure 5 times the human clinical exposure based on AUC in pediatric ITP patients at 75 mg/day) was associated with slight reductions in body weight gain and slight decreases in red cell parameters with an apparent regenerative increase in reticulocyte counts. Discoloration of the skin, fur and other organs (attributed to the color of eltrombopag) was observed in rat pups at very high systemic exposure and was reversible following an off-treatment period. In rat pups dosed from Days 32 to 63 pp, a dose of 40 mg/kg/day was associated with similar slight changes in red blood cell parameters and slight decreases in serum cholesterol and triglyceride concentrations.

Cataracts were observed in mice and rats. Development of cataracts is dose-, time- and age-dependent, i.e. the young rapidly developing lens epithelium of the mouse, was more susceptible than the older, developmentally quiescent lens epithelium. At non-tolerated doses (9 times the maximum human clinical exposure in pediatric ITP patients at 75 mg/day, based on AUC) in pre-weaning juvenile rats dosed from Days 4-32 pp

(approximately equating to a 2-year old human at the end of the dosing period), ocular opacities were observed. Cataracts were not observed in juvenile rats given tolerated doses at 5 times the human clinical exposure in pediatric ITP patients, based on AUC. In young mice (6 weeks of age at initiation of dosing) given 150 mg/kg eltrombopag, development of cataracts was observed with an onset of approximately 6 to 7 weeks at 5 times the maximum human clinical exposure in pediatric ITP patients at 75 mg/day, based on AUC. However, in mice 26-weeks of age at the initiation of dosing, a dose of 150 mg/kg/day did not cause cataract formation.

REFERENCES

1. Bussel J, Cheng G, Saleh M, et al. Eltrombopag for the Treatment of Chronic Idiopathic Thrombocytopenic Purpura. *N Eng J of Med* 2007; 357: 2237-47
2. Erickson-Miller , Connies L, Delorme, Evelyne, Hopson, Christopher B, et al. Preclinical Activity of Eltrombopag (SB-497115), an Oral, Non-peptide Thrombopoietin Receptor Agonist. *Stem Cells* 2008; 366: 1-19
3. Grainger D.J, Locatelli L., Chotsampancharoen T. et al. Eltrombopag for children with chronic immune thrombocytopenia (PETIT2): a randomised, multicentre, placebo-controlled trial. *Lancet* 2015; 386: 1649–58.
4. Jenkins J, Williams, D, Deng Y et al. Phase 1 Clinical Study of Eltrombopag, an Oral, Nonpeptide Thrombopoietin Receptor Agonist. *Blood* 2007; 109: 4739-4741
5. Stasi R, Evangelista M, Amadort S. Novel Thrombopoietic Agents-A review of their Use in Idiopathic Thrombocytopenic Purpura. *Drugs* 2008; 688(7): 901-912

PART III: CONSUMER INFORMATION

Pr **REVOLADE**[®] eltrombopag tablets (as eltrombopag olamine)

This leaflet is part III of a three-part "Product Monograph" published when REVOLADE was approved for sale in Canada and is designed specifically for Consumers. This leaflet is a summary and will not tell you everything about REVOLADE. Contact your doctor or pharmacist if you have any questions about the drug.

ABOUT THIS MEDICATION

What the medication is used for:

Chronic immune thrombocytopenia (ITP): REVOLADE is used to treat chronic immune thrombocytopenia (ITP). ITP is a bleeding disorder. REVOLADE is used to increase platelet counts in adults and children one year of age and older. It is used when other medications have not worked.

Severe Aplastic Anemia (SAA):

REVOLADE is used to treat adult patients with low blood counts caused by severe aplastic anemia (SAA). REVOLADE is used when other drugs don't work.

Chronic hepatitis C (HCV) associated thrombocytopenia: REVOLADE is used to treat HCV infections. HCV is a bleeding disorder. Many patients with HCV have low platelet counts not only due to the disease but also due to some of the treatment that are used to treat the disease. Taking REVOLADE may make it easier for patients to complete a full course of antiviral medicine.

What it does:

Treatment of ITP:

REVOLADE is a drug that may help increase the number of platelets.

Treatment of SAA:

REVOLADE is a drug that may help increase the number of platelets and other types of blood cells.

Treatment of HCV associated thrombocytopenia:

REVOLADE is a drug that may help increase the number of platelets.

When it should not be used:

Do not use REVOLADE if you:

- are allergic to REVOLADE or to any of its other

ingredients

- have severe liver problems

What the medicinal ingredient is:

eltrombopag

What the nonmedicinal ingredients are:

Tablets: Hypromellose, macrogol, magnesium stearate, mannitol, microcrystalline cellulose, povidone, sodium starch glycolate and titanium dioxide.

12.5 mg and 25 mg tablets also contain polysorbate.

50 mg tablets also contain iron oxide yellow and iron oxide red.

75 mg tablets also contain iron oxide red and iron oxide black.

What dosage forms it comes in:

Tablets: 12.5 mg, 25 mg, 50 mg, and 75 mg.

WARNINGS AND PRECAUTIONS

Serious Warnings and Precautions

Chronic hepatitis patients with liver disease may be at increased risk of liver failure and death when taking REVOLADE with pegylated interferon and ribavirin, which are used to treat hepatitis C. Your doctor may monitor your liver symptoms closely.

REVOLADE is only available as tablets. It should not be used in patients who are unable to swallow REVOLADE tablets whole.

Read the Consumer Information for these two drugs (pegylated interferon and ribavirin) for their key safety information. Both are used with REVOLADE when treating patients with HCV and ITP.

BEFORE you use REVOLADE, talk to your doctor or pharmacist if you:

- Have liver problems.
- Have kidney problems.
- Have a history of formation of a clot inside a blood vessel, obstructing the flow of blood (thrombosis), or you know that thrombosis occurs

frequently in your family. The risk of blood clots may be increased in certain conditions. For example if you: are elderly, have been bedridden, have cancer, are taking the birth control pill, or hormone replacement therapy, have recently had surgery or had an injury, are overweight, if you are a smoker.

- Have another blood condition, such as myelodysplastic syndrome (MDS). Your doctor will carry out tests to check that you do not have this blood condition before you start REVOLADE. If you have MDS and take REVOLADE, your MDS may get worse.
- Have a history of problems with sight (cataracts).
- Are pregnant or plan to become pregnant.
- Are breast-feeding or planning to breastfeed.
- Are over 65 years of age.
- Are of Asian descent.

Pregnancy:

You should avoid becoming pregnant while taking REVOLADE. Its effect of REVOLADE on pregnancy is not known. You should use a reliable method of contraception. If you become pregnant during treatment, tell your doctor.

Breast-feeding:

Studies in animals have shown that REVOLADE is likely to be present in milk. It is not known whether REVOLADE passes into breast milk. Breast-feeding is not recommended while you are taking REVOLADE.

Cataracts:

In animal studies it was found that REVOLADE caused the development of cataracts (a clouding of the lens in the eye). In HCV studies in patients with thrombocytopenia (low blood platelet count) also receiving interferon, an increased risk in the incidence of cataracts has also been seen. In chronic ITP studies, new cataracts have happened in patients receiving REVOLADE. In the chronic ITP studies with children, two cataract events occurred in patients given REVOLADE. Your doctor may recommend that you are checked for cataracts before and during REVOLADE therapy.

INTERACTIONS WITH THIS MEDICATION

Taking Other Medicines:

There are certain groups of medicines, including prescription and non-prescription medicines and vitamins that interact with REVOLADE and that you should not take at the same time while receiving a dose of REVOLADE. These medications include some products within the following groups:

- Antacid medicines to treat stomach ulcers, indigestion or heartburn
- Certain medicines used to lower cholesterol (statins)
- Minerals such as aluminum, calcium, iron, magnesium, selenium and zinc which may be found in mineral supplements

There are certain groups of medicines, requiring additional platelet monitoring. These medicines include lopinavir/ritonavir (medicines to treat HIV infection) and cyclosporine (used in the context of transplantations or immune diseases).

Talk to your doctor if you take any of these medications. In some cases, you may need to adjust the dose or alter the timing of the dose (see Usual dose). Ask your doctor or pharmacist to review the medicines you are currently taking and suggest suitable alternatives if necessary.

If you are also taking medicines which are given to prevent blood clots (anticoagulants or antiplatelet therapy), there is a greater risk of bleeding. You should discuss this with your doctor. If you are taking other medications for your treatment, these may be reduced or stopped when given together with REVOLADE.

Taking REVOLADE with Food and Drink:

Do not take REVOLADE with dairy products (e.g. milk, ice cream, yogurt, etc.).

REVOLADE may be taken with food low in calcium such as:

- Fruits such as pineapple, raisins and strawberries
- Lean ham, chicken or beef
- Unfortified fruit juice, soy milk and grain. (Unfortified means no added calcium, magnesium or iron).

Please discuss this matter with your doctor or pharmacist; they will be able to give you advice on the most suitable meals to be eaten while you are taking REVOLADE.

PROPER USE OF THIS MEDICATION

Swallow the tablets whole, with some water. Do NOT crush tablets and then mix with food or liquids.

Usual adult dose (18 years and above):

The usual starting dose for either adult ITP or adult SAA patients is **50 mg** REVOLADE once daily. People of Asian

origin (such as Chinese, Japanese, Taiwanese, Thai, or Korean) need to start at a lower dose of 25 mg.

The usual starting dose for adult HCV patients is **25 mg** REVOLADE once daily. People of Asian origin (such as Chinese, Japanese, Taiwanese, Thai or Korean) will start on the same 25 mg dose.

Usual dose for pediatric ITP patients (aged 1 to less than 18 years):

The usual starting dose for pediatric ITP patients 1 to 5 years of age is **25 mg** REVOLADE once daily.

The usual starting dose for pediatric ITP patients 6 to less than 18 years of age is **50 mg** REVOLADE once daily. Pediatric ITP patients 6 to less than 18 years of age of Asian origin (such as Chinese, Japanese, Taiwanese, Thai, or Korean) need to start at a lower dose of 25 mg.

If your child is not able to swallow the tablets whole, talk to your doctor or your pharmacist.

If you have liver disease and your doctor has decided to treat you for either ITP or SAA, your starting dose should be no more than 25 mg taken once daily.

Based on your response to REVOLADE your doctor will adapt the dose and may recommend that your daily dose of REVOLADE be increased or decreased.

ITP Patients: Do not exceed a dose of 75 mg once daily.

SAA Patients: Do not exceed a dose of 150 mg once daily.

HCV Associated Thrombocytopenia Patients: Do not exceed a dose of 100 mg once daily.

Do not stop taking REVOLADE until your doctor advises you to do so.

After your doctor advises you to stop treatment with REVOLADE, your platelet count will then be checked each week for 4 weeks.

Don't take REVOLADE during the 2 hours before or 4 hours after you take antacid medication (to treat indigestion), mineral supplements (such as aluminium, calcium, iron, magnesium, selenium or zinc), or dairy products. If you do, the medicine will not be properly absorbed into your body. One way to avoid issues with these products would be to take them in the morning and take REVOLADE in the evening. Ask your doctor or pharmacist for advice if you are unsure.

HCV Associated Thrombocytopenia Patients: Do not take REVOLADE for more than one year at a time.

Treatment should be reassessed by your doctor after one year. Once your anti-viral therapy has been discontinued treatment with REVOLADE will be stopped.

Overdose:

If you think you have taken too much REVOLADE, contact a health care practitioner, hospital emergency department or regional Poison Control Centre immediately, even if there are no symptoms.

Missed Dose:

If you miss a dose, take it as soon as you remember. Do not take a double dose to make up for a forgotten dose. Instead, wait until it is time for your next dose and then take your usual prescribed dose.

For any other questions on its use, ask your doctor or pharmacist.

SIDE EFFECTS AND WHAT TO DO ABOUT THEM

As with all medicines, REVOLADE can cause side effects.

Side effects reported with REVOLADE in the treatment of adult patients with ITP include:

- Headache
- Nausea
- Diarrhea
- Dry mouth
- Vomiting
- Rash
- Joint pain
- Dry eye
- Feeling hot
- Numbness or tingling of the skin
- Increased sweating
- Sore throat or discomfort when swallowing
- Fatigue

REVOLADE may cause the following abnormal blood test results:

- Increase in a liver enzyme called alanine aminotransferase
- Increase of a liver enzyme called aspartate aminotransferase;
Increase level of bilirubin (a substance produced by the liver) in the blood, which may produce jaundice (hyperbilirubinemia).

Side effects reported with REVOLADE in the treatment of children 1 year and older with ITP include:

- Sore throat, runny nose, nasal congestion and sneezing
- Infection in the nose, sinuses, throat and upper airways, common cold (*upper respiratory tract infection*)
- Cough
- Diarrhoea, constipation, nausea, indigestion
- Toothache, bleeding from the mouth
- Decreased appetite
- Runny nose
- Lung or skin infection, influenza, meningitis, enlarged tonsils, head lice
- Rash, itchy rash, scratching, bruising
- Vitamin D deficiency
- Motion sickness
- Changes in the back of the eye
- Pain, back pain, groin pain, osteoporosis, non-cardiac chest pain, skin or joint injury
- Lack of energy, sleepiness
- Numbness
- Eating disorder
- Allergic reaction

REVOLADE may cause the following abnormal blood test results:

- Changes in some enzymes produced by the liver

Side effects reported with REVOLADE in the treatment of patients with SAA include:

- Cough, runny nose
- pain in the mouth and throat, Anxiety and Depression
- Fever
- Headache, dizziness, fatigue (feeling very tired)
- Abdominal pain, diarrhea, nausea
- Muscle spasms
- Joint pain
- Pain in arms, legs, hands and feet
- Bleeding from the gums
- Pain or blisters inside the mouth
- Vomiting
- Weakness, lack of energy
- Chills
- Swelling of arms and legs
- Shortness of breath when walking
- Nosebleed
- Back pain

- Skin rash, itching, rash with pale red, raised, itchy bumps
- Patch of skin that looks different
- Dry eyes
- Trouble sleeping
- Feeling unwell, feeling pain
- Constipation, passing gas
- Abnormal colour of urine or feces
- Pain when swallowing
- Swollen tongue
- Decreased or increased appetite
- Pain in bones

REVOLADE may cause the following abnormal blood test results:

- Increase in some liver enzymes (transaminases)
- High levels of iron in your blood
- Low blood sugar levels
- Increased level of bilirubin in the blood, which may produce jaundice (hyperbilirubinemia).

Laboratory tests may show abnormal changes to the cells in your bone marrow.

Side effects reported with REVOLADE in the treatment of patients with HCV include:

- Fatigue
- Chills
- Headache
- Nausea
- Diarrhea
- Itching
- Feeling weak
- Difficulty sleeping
- Loss of appetite
- Flu-like symptoms
- Swelling of the hands, ankles or feet
- Cough

Please talk with your doctor if you experience skin discolouration as they can evaluate and manage this side effect appropriately.

REVOLADE may cause the following abnormal blood test results.

- Reduced number of red blood cells (*anemia*)
- Increased level of bilirubin in the blood, which may produce jaundice (hyperbilirubinemia)

SERIOUS SIDE EFFECTS, HOW OFTEN THEY HAPPEN AND WHAT TO DO ABOUT THEM

Symptom / effect		Talk with your doctor or pharmacist		Stop taking drug and seek immediate medical help
		Only if severe	In all cases	
Very common	Decreased Red Blood Cells (anemia): fatigue, loss of energy, weakness, shortness of breath		✓	
Common	Blood clots (thromboembolic events including portal vein thrombosis): swelling, pain or tenderness in one part of the body.		✓	
	Fever	✓		
	Abdominal pain/discomfort	✓		
	Sepsis: rapid heartbeat, fever, shaking chills, rapid breathing, nausea, vomiting, decreased urination		✓	
	Viral infection: fever, fatigue, headache, body aches, diarrhea, nausea, vomiting		✓	
	Oropharyngeal pain: pain in the nose and throat		✓	

SERIOUS SIDE EFFECTS, HOW OFTEN THEY HAPPEN AND WHAT TO DO ABOUT THEM

Symptom / effect	Talk with your doctor or pharmacist		Stop taking drug and seek immediate medical help
	Only if severe	In all cases	
Eye disorders: -Cataracts: clouded, blurred or dim vision, seeing halos around lights, fading or yellowing of colours -Blurred Vision -Visual impairment: changes in vision -Vitreous floaters: spots in vision that appear as specks or strings of floating material; spots that move with eye movement		✓	
Splenic infarction (spleen tissue death): severe pain in upper left side of abdomen that can radiate to left shoulder		✓	
Syncope and dizziness postural: fainting, dizziness when standing up or sitting down		✓	
Liver Problems (including Hepatitis B): Jaundice (yellow colour to skin, whites of the eyes), unusual dark urine, unusual tiredness, right upper stomach area pain		✓	

SERIOUS SIDE EFFECTS, HOW OFTEN THEY HAPPEN AND WHAT TO DO ABOUT THEM

Symptom / effect	Talk with your doctor or pharmacist		Stop taking drug and seek immediate medical help
	Only if severe	In all cases	
Liver failure: (serious disturbance of liver function, hepatic failure): Jaundice (yellow colour to skin, whites of the eyes), bleeding easily, swollen abdomen, mental disorientation or confusion, sleepiness, coma		✓	
Liver injury in HCV patients (loss of function of the liver): Abdominal pain, guarding (holding hand over the area), tenderness in the upper right part of the abdomen, right shoulder pain and signs of shock and blood loss		✓	
Hypoglycemia (low blood sugar): thirst, frequent urination, hunger, nausea and dizziness, fast heartbeat, tingling trembling, nervousness, sweating		✓	
Unusual hair loss or thinning		✓	
Myalgia: aching muscles		✓	

SERIOUS SIDE EFFECTS, HOW OFTEN THEY HAPPEN AND WHAT TO DO ABOUT THEM

Symptom / effect	Talk with your doctor or pharmacist		Stop taking drug and seek immediate medical help
	Only if severe	In all cases	
		✓	
	Urinary tract infections: pain and/or burning when urinating, blood in the urine, increased urge to urinate		
Uncommon	Allergic reactions: rash, hives, swelling of the face, lips, tongue or throat, difficulty swallowing or breathing		✓
	Bleeding		✓
	Thrombotic microangiopathy with acute renal failure (damage occurring in the smallest blood vessels inside the kidney leading to loss of kidney function): Decreased urine, swollen legs, high blood pressure		✓

SERIOUS SIDE EFFECTS, HOW OFTEN THEY HAPPEN AND WHAT TO DO ABOUT THEM

Symptom / effect	Talk with your doctor or pharmacist		Stop taking drug and seek immediate medical help
	Only if severe	In all cases	
		✓	
	Liver injury in ITP patients (loss of function of the liver): Abdominal pain, guarding (holding hand over the area), tenderness in the upper right part of the abdomen, right shoulder pain and signs of shock and blood loss		
	Musculoskeletal chest pain		✓
	Musculoskeletal pain (pain that affects the muscles and tendons along with bones): muscle pain, limb pain, joint pain and bone pain		✓

REVOLADE may cause serious side effects

Liver Problems:

REVOLADE may damage your liver and cause serious, even life threatening, illness. You must have blood tests to check your liver before you start taking REVOLADE and during treatment. When you are given antiviral treatments at the same time as with REVOLADE to treat HCV associated thrombocytopenia, some liver problems can get worse.

Your doctor will order the blood tests and any other tests required. In some cases, REVOLADE treatment may need to be stopped.

Bleeding after you stop treatment:

When you stop taking REVOLADE, your blood platelet count may drop back down to what it was before you started taking REVOLADE. These effects are highly likely to happen within 4 weeks after you stop taking REVOLADE. The lower platelet counts may increase your risk of bleeding. Your doctor will check your platelet counts for at least 4 weeks after you stop your treatment. Tell your doctor or pharmacist if you have any bruising or bleeding after you stop your treatment.

Problems with your bone marrow:

People with the disease for which you are being treated may have problems with their bone marrow. Drugs like REVOLADE help increase the number of platelets. This can increase the risk of bone marrow cell disorders, blood cancers, changes in DNA, or cause scarring of the bone marrow. Signs of bone marrow changes may show up as abnormal results in your blood tests. Your doctor may also carry out tests to directly check your bone marrow during treatment with REVOLADE.

High platelet counts and higher chance for blood clots:

You have a higher chance of getting a blood clot if your platelet count is too high during treatment with REVOLADE. But blood clots can occur with normal or even low platelet counts. If you have disease of the liver, you are at risk of a blood clot in a blood vessel that feeds your liver (portal vein thrombosis). You may have severe complications from some forms of blood clots, such as clots that travel to the lungs or that cause heart attacks or strokes. You may have clots in small blood vessels, which may harm organs such as the kidneys. Your doctor will check your blood platelet counts, and change your dose or stop REVOLADE if your platelet counts get too high. Tell your doctor right away if you have any of these signs and symptoms of a blood clot: swelling or pain/tenderness of one leg, sudden shortness of breath especially when accompanied with sharp pain in the chest and/or rapid breathing, abdominal pain, enlarged abdomen, blood in stool.

This is not a complete list of side effects. For any unexpected effects while taking REVOLADE contact your doctor or pharmacist.

HOW TO STORE IT

Keep out of reach of children.

Tablets: Store below 30°C, protect from freezing.

REPORTING SIDE EFFECTS

You can report any suspected side effects associated with the use of health products to Health Canada by:

- Visiting the Web page on Adverse Reaction Reporting (<https://www.canada.ca/en/health-canada/services/drugs-health-products/medeffect-canada/adverse-reaction-reporting.html>) for information on how to report online, by mail or by fax; or
- Calling toll-free at 1-866-234-2345.

NOTE: Contact your health professional if you need information about how to manage your side effects. The Canada Vigilance Program does not provide medical advice.

MORE INFORMATION

This document plus the full product monograph, prepared for health professionals can be found at:

<http://www.novartis.ca> or by contacting the sponsor,

Novartis Pharmaceuticals Canada Inc.

385 Bouchard Blvd.

Dorval, Quebec

H9S 1A9

1-800-363-8883

This leaflet was prepared by Novartis Pharmaceuticals Canada Inc.

Date of Revision: May 15, 2019

REVOLADE is a registered trademark

**All trademarks and registered trademarks are the property of their respective owners.*

PRODUCT MONOGRAPH
INCLUDING PATIENT MEDICATION INFORMATION

Pr**SPRYCEL**[®]

dasatinib
Tablets

20 mg, 50 mg, 70 mg, 80 mg, 100 mg and 140 mg dasatinib (as monohydrate)

Protein kinase inhibitor

Bristol-Myers Squibb Canada
Montréal, Canada

Registered trademark of Bristol-Myers Squibb Holdings Ireland used
under license by Bristol-Myers Squibb Canada Co.

Date of Preparation:

22 March 2007

Date of Revision:

August 25, 2020

Submission Control No: 229858

RECENT MAJOR LABEL CHANGES

Dosage and Administration, Dose reduction for concomitant use of strong CYP3A4 inhibitors	08/2020
Dosage and Administration, Dose Adjustment for Adverse Reactions	08/2020

Table of Contents

PART I: HEALTH PROFESSIONAL INFORMATION.....	3
SUMMARY PRODUCT INFORMATION	3
INDICATIONS AND CLINICAL USE.....	3
CONTRAINDICATIONS	4
WARNINGS AND PRECAUTIONS.....	4
ADVERSE REACTIONS.....	13
DRUG INTERACTIONS	28
DOSAGE AND ADMINISTRATION	30
OVERDOSAGE	32
ACTION AND CLINICAL PHARMACOLOGY	33
STORAGE AND STABILITY.....	34
SPECIAL HANDLING INSTRUCTIONS	35
DOSAGE FORMS, COMPOSITION AND PACKAGING	35
PART II: SCIENTIFIC INFORMATION.....	36
PHARMACEUTICAL INFORMATION.....	36
CLINICAL TRIALS.....	36
DETAILED PHARMACOLOGY	43
TOXICOLOGY	45
REFERENCES	59
PATIENT MEDICATION INFORMATION	60

SPRYCEL
(dasatinib)

PART I: HEALTH PROFESSIONAL INFORMATION

SUMMARY PRODUCT INFORMATION

Route of Administration	Pharmaceutical Form/Strength	Clinically Relevant Non medicinal Ingredients
Oral	Tablet 20 mg, 50 mg, 70 mg, 80 mg, 100 mg and 140 mg	Lactose monohydrate. <i>For a complete listing see Dosage Forms, Composition and Packaging section.</i>

INDICATIONS AND CLINICAL USE

SPRYCEL (dasatinib) is indicated for the treatment of adults with:

- Newly diagnosed Philadelphia chromosome positive (Ph+) chronic myeloid leukemia (CML) in chronic phase.

Clinical effectiveness of SPRYCEL treatment in patients with newly diagnosed Ph+ CML in chronic phase is based on confirmed complete cytogenetic response rate (cCCyR) within 12 months. As of the 60 month cut-off date, overall survival, prevention of progression to advanced stage CML, or time-in cCCyR benefits have not been demonstrated (see CLINICAL TRIALS).

- Ph+ chronic, accelerated, or blast phase chronic myeloid leukemia (CML) with resistance or intolerance to prior therapy including imatinib mesylate.

Clinical effectiveness of SPRYCEL in CML is based on the rates of hematologic and cytogenetic responses in clinical trials with a minimum of 24 months of follow-up (see CLINICAL TRIALS).

- Ph+ acute lymphoblastic leukemia (ALL) with resistance or intolerance to prior therapy.

Clinical effectiveness in Ph+ ALL is based on the rates of hematologic and cytogenetic responses in clinical trials with a minimum of 24 months of follow-up (see CLINICAL TRIALS).

SPRYCEL (dasatinib) should only be prescribed by a qualified physician who is experienced in the use of antineoplastic therapy.

Geriatrics (≥ 65 years of age):

While the safety profile of SPRYCEL in the geriatric population was similar to that in the younger population, patients aged 65 years and older are more likely to experience the commonly reported adverse events diarrhea, fatigue, cough, pleural effusion, dyspnea, dizziness, peripheral edema, pneumonia, hypertension, arrhythmia, congestive heart failure, pericardial effusion, lower

gastrointestinal hemorrhage, abdominal distension and more likely to experience the less frequently reported events pulmonary edema, lung infiltration, arthritis, and urinary frequency and should be monitored closely. No differences in cCCyR and MMR were observed between older and younger patients. However, in the two randomized studies in patients with imatinib resistant or intolerant chronic phase CML, the rates of major cytogenetic response (MCyR) at 2 years were lower among patients aged 65 years and older (42% MCyR in patients \geq 65 years versus 56% MCyR in the rest of the study population and 47% MCyR in patients \geq 65 years versus 68% MCyR in the rest of the study population in studies CA180017 and CA180034, respectively).

Pediatrics (< 18 years of age):

The safety and efficacy of SPRYCEL in patients <18 years of age have not been established. Nonclinical studies demonstrated greater toxicity in rat pups (See WARNINGS AND PRECAUTIONS- Special populations).

CONTRAINDICATIONS

- Use of SPRYCEL is contraindicated in patients with hypersensitivity to dasatinib or to any other component of SPRYCEL.
- Breastfeeding is contraindicated in women taking dasatinib.

WARNINGS AND PRECAUTIONS

Serious Warnings and Precautions

- SPRYCEL (dasatinib) should only be prescribed by a qualified physician who is experienced in the use of antineoplastic therapy.
- Myelosuppression: thrombocytopenia, neutropenia, and anemia (see Myelosuppression below).
- Hemorrhage, including fatal outcomes (see Hemorrhage).
- Fluid retention, pleural effusion, pulmonary edema and–pericardial effusion (see Fluid Retention below).
- Congestive heart failure (see Cardiovascular below).
- Pulmonary arterial hypertension (See below)

Carcinogenesis and Mutagenesis

In a 2-year carcinogenicity study in rats at doses up to 3 mg/kg/day (approximately equal to the human clinical exposure), a statistically significant increase in the combined incidence of squamous cell carcinomas and papillomas in the uterus and cervix in females and of prostate adenoma in males was noted (see TOXICOLOGY). The relevance of the findings from the rat carcinogenicity study for humans is not known.

Dasatinib was clastogenic in vitro to dividing Chinese hamster ovary cells with and without metabolic activation at concentrations ranging from 5 to 60 µg/mL. Dasatinib was not mutagenic when tested in in vitro bacterial cell assays (Ames test) and was not genotoxic in an in vivo rat micronucleus study.

Cardiovascular

The Phase III clinical study in patients with newly diagnosed CML in chronic phase excluded patients with uncontrolled or significant cardiovascular disease. The SPRYCEL arm (n=258) included 1.6 % of patients with prior cardiac disease and 24% with baseline cardiovascular risk factors. Cardiac adverse reactions of congestive heart failure/cardiac dysfunction, pericardial effusion, arrhythmias, palpitations, QT prolongation, and myocardial infarction (including fatal) were reported in patients taking SPRYCEL (see ADVERSE REACTIONS). Severe pericardial effusion (1.2%) and arrhythmia (0.4%) were also reported in patients. Adverse cardiac events were more frequent in patients with cardiovascular risk factors or a previous medical history of cardiac disease (see ADVERSE REACTIONS). Patients with risk factors or a history of cardiac disease should be evaluated at baseline and monitored carefully for clinical signs or symptoms consistent with cardiac dysfunction (such as chest pain, shortness of breath, and diaphoresis) during routine follow up.

In the Phase III clinical trials in patients with resistance or intolerance to prior imatinib therapy, patients were excluded from enrolment for a broad range of cardiac events or conditions. A significantly abnormal ECG at screening was also an exclusion criterion. No prospective evaluation of cardiac function was carried out.

In all clinical trials with patients resistant or intolerant to prior imatinib therapy, congestive heart failure/cardiac dysfunction was reported in 96 (4%) of subjects, of which 49 (2%) were considered to be severe. In some cases, the event was triggered by an acute volume load, including transfusion of blood products.

QT Prolongation: *In vitro* data suggest that dasatinib and its N-dealkylated metabolite, BMS-582691 have the potential to prolong cardiac ventricular repolarization (QT interval, see Safety Pharmacology).

In 865 patients with leukemia treated with SPRYCEL in Phase II clinical studies, the mean changes from baseline in QTcF interval were 4–6 msec; the upper 95% confidence intervals for all mean changes from baseline were <7 msec. Of the 2182 patients with resistance or intolerance to prior imatinib therapy who received SPRYCEL in clinical studies, 21 patients (<1%) experienced a QTcF >500 msec.

In the Phase III clinical study in patients with newly diagnosed CML in chronic phase, patients with baseline QTcF interval > 450 msec were excluded. After 5 years of follow-up, QTc prolongation was reported in one patient (<1%) who experienced a QTcF >500 msec and discontinued SPRYCEL treatment. SPRYCEL should be administered with caution in patients who have or may develop prolongation of QTc. These include patients with hypokalemia or hypomagnesemia, patients with congenital long QT syndrome, patients taking anti arrhythmic

medicines or other medicinal products that lead to QT prolongation, and cumulative high-dose anthracycline therapy.

Hypokalemia or hypomagnesemia should be corrected prior to administration of SPRYCEL. (See Drug-Drug Interactions below, DRUG INTERACTIONS, ACTION AND CLINICAL PHARMACOLOGY: Electrocardiogram.)

Drug-Drug Interactions

CYP3A4 inhibitors: Concomitant use of dasatinib and medicinal products that potently inhibit CYP3A4 (e.g. ketoconazole, itraconazole, erythromycin, clarithromycin, ritonavir, atazanavir, lopinavir, grape fruit juice) may increase exposure to dasatinib. Therefore, in patients receiving SPRYCEL, coadministration of a potent CYP3A4 inhibitor is not recommended. Selection of an alternate concomitant medication with no or minimal CYP3A4 inhibition potential is recommended. If systemic administration of a potent CYP3A4 inhibitor cannot be avoided, close monitoring for toxicity and a SPRYCEL dose reduction to 20 or 40 mg daily should be considered (see DRUG INTERACTIONS and DOSAGE AND ADMINISTRATION).

CYP3A4 inducers: Concomitant use of dasatinib and medicinal products that induce CYP3A4 (e.g. dexamethasone, phenytoin, carbamazepine, rifampicin, phenobarbital or Hypericum perforatum, also known as St. John's Wort) may substantially reduce exposure to dasatinib, potentially increasing the risk of therapeutic failure. In addition, more healthy male subjects experienced increases in QTcF of > 30 msec from the baseline ECG recordings when dasatinib and rifampicin were administered 12 hours apart compared to when dasatinib was administered alone (25% vs. 10%). No subject experienced QTcF > 450 msec or a change from baseline > 60 msec. (see DRUG INTERACTIONS). Therefore, concomitant use of potent CYP3A4 inducers with dasatinib is not recommended. In patients in whom rifampicin or other CYP3A4 inducers are indicated, alternative agents with less enzyme induction potential should be used.

CYP3A4 substrates: Concomitant use of dasatinib and a CYP3A4 substrate may increase exposure to the CYP3A4 substrate. In addition, three healthy subjects (n = 48) experienced increases in QTcF of > 30 msec from the baseline ECG recordings following concomitant use of a single dose of dasatinib and simvastatin. No subject experienced QTcF > 450 msec or a change from baseline > 60 msec (see DRUG INTERACTIONS). Therefore, caution is warranted when SPRYCEL is co-administered with a drug that potentially alters CYP3A4 activity, a QTc prolonger, or CYP3A4 substrates of narrow therapeutic index such as cyclosporine, macrolide antibiotics, benzodiazepine, pimozide, or ergot alkaloids (ergotamine, dihydroergotamine). The effect of a CYP3A4 substrate on the pharmacokinetic parameters of dasatinib has not been studied.

H2 antagonists or proton pump inhibitors: Long-term suppression of gastric acid secretion by H2 antagonists or proton pump inhibitors (e.g. cimetidine, ranitidine, famotidine and omeprazole) is likely to reduce dasatinib exposure (see DRUG INTERACTIONS). **The use of antacids should be considered in place of H2 antagonists or proton pump inhibitors in patients receiving SPRYCEL therapy.**

Antacids: Concomitant use of dasatinib and aluminum hydroxide/magnesium hydroxide may reduce exposure to dasatinib. However, **aluminum hydroxide/magnesium hydroxide products may be administered up to 2 hours prior to, or 2 hours following the administration of dasatinib** (see DRUG INTERACTIONS).

Antiemetics: No information is available on the safety of concomitant use of dasatinib with antiemetics (prochlorperazine, metochlopramide, 5-HT₃ inhibitors).

Lactose

SPRYCEL tablets 20 mg, 50 mg, 70 mg, 80 mg, 100 mg and 140 mg contain lactose in proportional amounts of 27 mg, 67.5 mg, 94.5 mg, 108 mg, 135 mg and 189 mg, respectively. SPRYCEL therefore contains 189 mg of lactose in the 140 mg daily dose of dasatinib and 135 mg in the 100 mg daily dose. Patients with rare hereditary problems of galactose intolerance, the Lapp lactase deficiency or glucose-galactose malabsorption should not take dasatinib.

Fluid Retention

SPRYCEL is associated with fluid retention. Patients with pre-existing pleural effusion were excluded from Phase III studies.

In the Phase III dose-optimization studies in patients with resistance or intolerance to prior imatinib therapy, severe fluid retention was reported in 11% of patients, including severe pleural and pericardial effusion reported in 7% and 2% of patients, respectively. Severe ascites and generalized edema were each reported in <1% of patients. Other manifestations of fluid retention in these studies included pulmonary edema (3%), congestive heart failure/cardiac dysfunction (4%), and pericardial effusion (5%). Nineteen patients had severe pulmonary edema. In patients with chronic phase CML with resistance or intolerance to prior imatinib therapy, Grade 3 or 4 fluid retention events were reported less frequently in patients treated with 100 mg once daily (5%) than in patients treated with 140 mg once daily (9%) (See ADVERSE REACTIONS). In these studies, fluid retention events were typically managed by supportive care measures that include diuretics or short courses of steroids. Pleural effusion required oxygen in some cases and at least one thoracentesis in 64 (3%) patients.

In the Phase III study conducted with newly diagnosed chronic phase CML patients, grades 1-4 fluid retention and pleural effusion were reported in 22% and 10%, respectively, by 12 months of treatment (see ADVERSE REACTIONS). The median time to onset of pleural effusion was 28 weeks (range 4-88 weeks). With appropriate medical care, 23 patients (88% of those with pleural effusion) were able to continue on SPRYCEL. After 5 years follow-up, fluid retention and pleural effusion were reported in 43% and 29% of patients, respectively. The median time to first grade 1-2 pleural effusion was 114 weeks and to first grade 3-4 pleural effusions was 175 weeks. Dasatinib treatment was discontinued due to pleural effusion in 5.8% of all dasatinib-treated patients. Out of patients with a pleural effusion, dasatinib treatment was interrupted in 62% and dose reduced in 41%, and was also managed through the use of diuretics or other appropriate supportive care measures.

In all patients with newly diagnosed or imatinib resistant or intolerant patients with chronic phase CML (n=548), severe fluid retention occurred in 36 (7%) patients receiving SPRYCEL at the recommended dose. In patients with advanced phase CML or Ph+ ALL treated with SPRYCEL at the recommended dose (n=304), severe fluid retention was reported in 11% of patients, including severe pleural effusion reported in 8% of patients.

Patients who develop symptoms suggestive of pleural effusion or other fluid retention such as new or worsened dyspnea on exertion or at rest, pleuritic chest pain, or dry cough should be evaluated promptly with chest X-ray or additional diagnostic imaging as appropriate (see DOSAGE AND ADMINISTRATION and ADVERSE REACTIONS). Consider treatment interruption, dose reduction, or treatment discontinuation.

Hemorrhage

Nonclinical studies have shown that dasatinib inhibits platelet aggregation in vitro and in vivo and increases bleeding time in vivo (see TOXICOLOGY: Other Toxicity Studies). Patients with a history of significant bleeding disorder unrelated to CML were excluded in SPRYCEL clinical studies. Patients taking concomitant medications that inhibit platelet function or anticoagulants were excluded in initial imatinib-resistant SPRYCEL (dasatinib) clinical studies. In subsequent trials, the use of anticoagulants, aspirin, and non-steroidal anti-inflammatory drugs (NSAIDs) was allowed concurrently with SPRYCEL if the platelet count was >50,000 per microliter. Caution should be exercised when SPRYCEL is to be concurrently administered with anticoagulants (see DRUG INTERACTIONS).

In clinical studies in 2,712 CML or Ph+ ALL patients with a median duration of therapy of 19.2 months (range 0- 93.2 months), 272 (10%) patients experienced Grade 3-4 bleeding. Fifty-six (2%) patients experienced fatal bleeding. In 23 (1%) of these patients, fatal bleeding occurred more than 30 days after dasatinib discontinuation.

Intracranial hemorrhage occurred in 66 (2.4%) of 2,712 CML or Ph+ ALL patients, of which 27 (1%) cases were considered related to SPRYCEL. Intracranial hemorrhage was fatal in 25 (0.9%) of these patients, of which ten (0.4%) cases were considered related to SPRYCEL.

Gastrointestinal hemorrhage regardless of relationship to SPRYCEL occurred in 15 % of 2,712 CML or Ph+ ALL patients. The bleeding was severe in 6 % of these patients and generally required treatment interruptions and packed cell transfusions. Other episodes of severe bleeding occurred in 3% of patients.

Grade 3-4 hemorrhages were reported in 2.3% of 258 patients with newly diagnosed chronic phase CML (see ADVERSE REACTIONS).

Hepatic Impairment

The effect of hepatic impairment on the single-dose pharmacokinetics of dasatinib was assessed in 8 moderately hepatic impaired subjects who received a 50-mg dose and 5 severely hepatic-impaired subjects who received a 20-mg dose compared to matched healthy subjects who received a 70-mg dose of SPRYCEL. Hepatic impairment did not result in clinically meaningful change in

dasatinib exposure at the doses studied. However no pharmacokinetic information is available from patients with hepatic impairment treated with a 70-100 mg dose of SPRYCEL (see ACTION AND CLINICAL PHARMACOLOGY: Pharmacokinetics - Special Populations and Conditions). Due to the limitations of this clinical study, caution is recommended in patients with hepatic impairment.

In nonclinical studies, increased liver weight and foci of hepatocellular alteration were observed in rats, and hepatocellular vacuolation was observed in monkeys following repeat dose administration of dasatinib (6 to 9 months). Increased ALT was observed in monkeys, and increased AST and/or decreased albumin were observed in rats and monkeys.

In clinical studies with 2,712 patients, 4 cases of hepatotoxicity, 4 cases of hepatocellular injury, 4 cases of hepatic steatosis, 2 cases of jaundice, 2 cases of liver disorder, 1 case of toxic hepatitis, 1 case of hepatic failure, 2 cases of abnormal hepatic function and 1 case of hepatitis were observed.

Immune

Hepatitis B virus reactivation

Reactivation of hepatitis B virus (HBV) has occurred in patients who are chronic carriers of this virus after receiving a BCR-ABL tyrosine kinase inhibitor (TKI), including SPRYCEL. Some cases resulted in acute hepatic failure or fulminant hepatitis leading to liver transplantation or death.

Patients should be tested for HBV infection before initiating treatment with SPRYCEL. Experts in liver disease and in the treatment of HBV should be consulted before treatment is initiated in patients with positive HBV serology (including those with active disease) and for patients who test positive for HBV infection during treatment. Carriers of HBV who require treatment with SPRYCEL should be closely monitored for signs and symptoms of active HBV infection throughout therapy and for several months following termination of therapy.

Myelosuppression

Treatment with SPRYCEL (dasatinib) is associated with thrombocytopenia, neutropenia, and anemia which occur earlier and more frequently in patients with advanced phase CML or Ph+ ALL than in patients with chronic phase CML. In a Phase III dose-optimization study in patients with chronic phase CML with resistance or intolerance to prior imatinib therapy with a minimum follow-up of 24 months, Grade 3 or 4 myelosuppression was reported less frequently in patients treated with 100 mg once daily (neutropenia 35%, thrombocytopenia 23% and anemia 13%) than in patients treated with 70 mg twice daily (neutropenia 45%, thrombocytopenia 38% and anemia 18%). Severe febrile neutropenia (including fatal outcomes) was reported in 2% of chronic phase patients and 14% of advanced phase CML patients.

In patients with advanced phase CML or Ph+ ALL treated with dasatinib complete blood counts (CBCs) should be performed weekly for the first 2 months and then monthly thereafter, or as clinically indicated.

In patients with chronic phase CML, CBCs should be performed every 2 weeks for 12 weeks, then every 3 months thereafter or as clinically indicated.

Myelosuppression was generally reversible and usually managed by withholding SPRYCEL temporarily or dose reduction (see DOSAGE AND ADMINISTRATION and ADVERSE REACTIONS: Abnormal Hematologic and Clinical Chemistry Findings). In clinical studies in patients with resistance or intolerance to prior imatinib therapy, severe (CTC Grade 3 or 4) cases of anemia were managed with blood transfusions. Packed red blood cells were transfused in 30% of chronic phase CML patients and 79% of myeloid blast phase CML patients. Platelet transfusions were required in 17% of chronic phase CML patients and 66% of myeloid blast phase CML patients.

Monitoring and Laboratory Tests

In patients with chronic phase CML, complete blood counts (CBCs) should be performed every two weeks for 12 weeks, then every 3 months thereafter, or as clinically indicated. In patients with advanced phase CML or Ph+ ALL, CBC should be performed weekly for the first 2 months and then monthly thereafter, or as clinically indicated (see WARNINGS AND PRECAUTIONS: Myelosuppression).

Hepatic function tests (AST, ALT and bilirubin), CK and renal function tests should be performed every two weeks for the first 2 months and then monthly thereafter or as clinically indicated (see WARNINGS AND PRECAUTIONS: Hepatic Impairment and Rhabdomyolysis).

Pulmonary Arterial Hypertension

Serious cases of pulmonary arterial hypertension (PAH), confirmed by right heart catheterization, have been associated with SPRYCEL treatment in clinical trials and post-marketing reports. In these cases, PAH was reported after initiation of SPRYCEL therapy, including after more than one year of treatment. In the Phase III clinical study in patients with newly diagnosed CML in chronic phase, drug-related pulmonary hypertension was reported in 4.7% of dasatinib-treated patients (N= 12) compared to 0.4% of imatinib-treated patients. Additional evaluation by right heart catheterization to determine if PAH was present was only performed in one case where PAH was not identified and pulmonary hypertension was not confirmed.

Patients should be evaluated for signs and symptoms of underlying cardiopulmonary disease prior to initiating SPRYCEL therapy. Patients who develop symptoms suggestive of PAH such as dyspnea and fatigue after initiation of therapy should be evaluated for more common etiologies including pleural effusion, pulmonary edema, anemia, or lung infiltration. If no alternative diagnosis is found, the diagnosis of PAH should be considered. If the symptoms are severe, SPRYCEL should be withheld during this evaluation. SPRYCEL should be permanently discontinued if PAH is confirmed (see DOSAGE AND ADMINISTRATION). Follow up on patients with PAH should be performed according to standard practice guidelines. Improvements in hemodynamic and clinical parameters have been observed in patients with PAH following cessation of SPRYCEL therapy.

Renal Impairment

There are currently no clinical studies with SPRYCEL in patients with impaired renal function. The study in patients with newly diagnosed chronic phase CML excluded patients with serum creatinine concentration > 3 times the upper limit of the normal range, and studies in patients with chronic phase CML with resistance or intolerance to prior imatinib therapy excluded patients with serum creatinine concentration >1.5 times the upper limit of the normal range. Dasatinib and its metabolites are minimally excreted via the kidney. Since the renal excretion of unchanged dasatinib and its metabolites is <4%, a decrease in total body clearance is not expected in patients with renal insufficiency. The effect of dialysis on dasatinib pharmacokinetics has not been studied.

Rhabdomyolysis

Cases of rhabdomyolysis with acute renal failure have been reported. Patients with muscle symptoms (muscle aches/pains) should be investigated to rule out rhabdomyolysis (elevated creatine kinase, elevated serum creatinine, hyperkalemia, hyperphosphatemia, brown urine, elevated ALT and AST).

Sexual Health

Reproduction

Dasatinib can cause fetal harm when administered to pregnant women. Knowledge of the potential effects of SPRYCEL on the sperm of male patients, and the level of maternal or fetal exposure from the semen of male SPRYCEL patients, is limited. Sexually active male patients or female patients of child bearing potential taking SPRYCEL should use highly effective contraception.

Fertility

The effects of SPRYCEL on male and female fertility in humans are not known. Based on animal studies, SPRYCEL may impair fertility in females of reproductive potential (See Non-Clinical Toxicology).

Skin - Severe dermatologic reactions

Individual cases of severe mucocutaneous dermatologic reactions, including Stevens-Johnson syndrome and erythema multiforme, have been reported with the use of SPRYCEL. SPRYCEL should be permanently discontinued in patients who experience a severe mucocutaneous reaction during treatment if no other etiology can be identified.

Special Populations:

Pregnant Women:

Dasatinib can cause fetal harm when administered to pregnant women. There have been post-marketing reports of spontaneous abortion and fetal and infant anomalies from women who have taken SPRYCEL during pregnancy (see ADVERSE REACTIONS). Studies in animals have shown that at concentrations which are readily achievable in humans receiving therapeutic doses

of SPRYCEL, fetal toxicity (embryofetal lethality, skeletal abnormalities including malformations) was observed in both pregnant rats and rabbits. Fetal death was observed in rats (see TOXICOLOGY).

SPRYCEL therefore should not be used in women who are pregnant or contemplating pregnancy. Women of child bearing potential must be advised to use highly effective contraception (i.e. a method of birth control that results in a failure rate less than 1% per year when used consistently and correctly) during SPRYCEL treatment. If SPRYCEL is used during pregnancy, or if the patient becomes pregnant while taking SPRYCEL, the patient should be apprised of the potential hazard to the fetus.

Nursing Women:

It is unknown whether SPRYCEL is excreted in human milk. In an exploratory pre- and post-natal development study in rats, postnatal exposure to dasatinib through lactation resulted in pleural effusion and mortality in pups before postnatal age of 20 days at an exposure of 0.27 times the adult clinical dose (see TOXICOLOGY). Women who are taking SPRYCEL must not breastfeed (See CONTRAINDICATIONS).

Pediatrics (<18 years of age):

The safety and efficacy of SPRYCEL in patients <18 years of age have not been established. Based on findings from the rat study described above (see Nursing Women), SPRYCEL should not be used in children under two years of age.

Geriatrics (≥ 65 years of age):

In the newly diagnosed chronic phase CML study, 25 patients (10%) were 65 years of age and older and 7 patients (3%) were 75 years of age and older. Patients of 65 years and over had more serious adverse events reported (any or drug-related) compared to those under 65 years (40.7% vs. 29.7%, 16.7% vs. 12.1%, respectively). Of the 2,712 patients in clinical studies of SPRYCEL, 617 (23%) were 65 years of age and older and 123 (5%) were 75 years of age and older. While the safety profile of SPRYCEL in the geriatric population was similar to that in the younger population, patients aged 65 years and older are more likely to experience the commonly reported adverse reactions diarrhea, fatigue, cough, pleural effusion, dyspnea, dizziness, peripheral edema, pneumonia, hypertension, arrhythmia, congestive heart failure, pericardial effusion, lower gastrointestinal hemorrhage, abdominal distension and more likely to experience the less frequently reported events pulmonary edema, lung infiltration, arthritis, and urinary frequency and should be monitored closely. No differences in cCCyR and MMR were observed between older and younger patients. However, in the two randomized studies in patients with imatinib resistant or intolerant chronic phase CML, the rates of major cytogenetic response (MCyR) at 2 years were lower among patients aged 65 years and older (42% MCyR in patients ≥ 65 years versus 56% MCyR in the rest of the study population and 47% MCyR in patients ≥ 65 years versus 68% MCyR in the rest of the study population in studies CA180017 and CA180034, respectively).

ADVERSE REACTIONS

Adverse Drug Reaction Overview

The data described below reflect exposure to SPRYCEL at all doses studied from clinical studies in 2,712 patients, including 324 patients with newly diagnosed chronic phase CML and 2388 patients with imatinib intolerant or resistant chronic or advanced phase CML or Ph+ ALL. The median duration of therapy in 2,712 SPRYCEL treated patients was 19.2 months (range 0- 93.2 months).

The majority of SPRYCEL-treated patients experienced adverse events at some time. Most events were mild to moderate. In the overall population of 2,712 SPRYCEL-treated subjects, 798 (29.4%) experienced adverse events leading to treatment discontinuation. Among the 258 patients in the Phase III newly diagnosed chronic phase CML study with follow up over a minimum of 60 months, serious adverse events, regardless of relationship to SPRYCEL, were reported in 35% of patients treated with SPRYCEL. A total of 69% of patients had dose interruption and 37% had dose reduction.

SPRYCEL was discontinued due to study drug toxicity in 14% of SPRYCEL-treated patients with a minimum of 60 months follow-up. The reasons for discontinuation were thrombocytopenia, leukopenia, pleural effusion, colitis, creatinine kinase increased, pericardial effusion, prolonged QTc interval, chest pain, optic neuritis, pulmonary hypertension, dyspnea, pleurisy, pneumothorax, acute myocardial infarction, abdominal discomfort, abdominal pain, colitis, diarrhea, peripheral edema, and acute renal failure.

Among the 1,618 SPRYCEL-treated subjects with chronic phase CML, adverse reactions leading to discontinuation were reported in 329 (20.3%) subjects, and among the 1,094 SPRYCEL-treated subjects with advanced phase disease (including Ph+ ALL), adverse reactions leading to discontinuation were reported in 191 (17.5%) subjects.

In a Phase III dose-optimization study in chronic phase CML patients resistant or intolerant to prior imatinib therapy with a minimum of 84 months follow-up, the rate of discontinuation for adverse reactions was 21% in patients treated with 100 mg once daily.

The median time to onset for Grade 1 or 2 pleural effusion events was 114 weeks (range 4-299 weeks). Fewer than 3% of pleural effusion events were Grade 3 or 4. With appropriate medical care, 58 patients (80% of those with pleural effusion) were able to continue on SPRYCEL (See WARNINGS AND PRECAUTIONS).

With a minimum of 60 months of follow up, the most frequently adverse events reported in SPRYCEL-treated patients with newly diagnosed chronic phase CML were fluid retention (including pleural effusion, superficial edema, pulmonary hypertension, generalized edema, pericardial effusion, congestive heart failure/cardiac dysfunction, pulmonary edema), diarrhea, infection (including bacterial, viral, fungal and non-specified), upper respiratory tract infection/inflammation, musculoskeletal pain, headache, cough, rash, pyrexia, and abdominal pain.

With a minimum of 84 months of follow up, in 165 patients with chronic phase CML resistant or intolerant to prior imatinib therapy treated with the recommended dose of 100 mg once daily, the most frequently reported adverse events, regardless of causality or severity, were diarrhea, fluid retention, headache, musculoskeletal pain, hemorrhage, pyrexia, fatigue, infection, skin rash, nausea, dyspnea, cough, upper respiratory tract infection/inflammation, vomiting, pain, abdominal pain, arthralgia, myalgia, pruritis and constipation.

Clinical Trial Adverse Drug Reactions in patients treated with SPRYCEL

Newly diagnosed patients with chronic phase CML

In the Phase III study in patients with newly diagnosed chronic phase CML the median duration of therapy was 60 months for both groups (range: < 1 to 73 months for the SPRYCEL group and <1 month to 75 months in the imatinib group); the median average daily dose was 99 mg and 400 mg, respectively.

All treatment-emergent adverse events (excluding laboratory abnormalities), regardless of relationship to study drug, that were reported in at least 5% of the patients are shown in Table 1.

A total of 26 (10%) SPRYCEL-treated patients died (11 of infections and 2 of myocardial infarction) and a total of 26 patients (10%) in the imatinib arm died (including 1 of myocardial infarction, 1 of pneumonia, 1 of fatal bleeding at time of disease progression and 2 of unknown cause/clinical deterioration and decrease in performance status).

Table 1: Adverse Events Reported in ≥5% of Patients with Newly Diagnosed Chronic Phase CML - 60 month follow up

SYSTEM ORGAN CLASS/ Preferred Term	SPRYCEL 100 mg QD (n=258)		Imatinib 400 mg QD (n=258)	
	All Grades	Grade 3/4	All Grades	Grade 3/4
Any Adverse Event	95	27	95	24
GENERAL DISORDERS AND ADMINISTRATION SITE CONDITIONS				
Face edema	12	0	38	0
Pyrexia	23	1	20	<1
Fatigue	16	<1	16	0
Pain	16	1	15	<1
Asthenia	16	0	14	1
Peripheral edema	9	0	13	<1
Chest pain	11	0	5	0
Generalized edema	5	0	9	0
GASTROINTESTINAL DISORDERS				
Diarrhea	40	2	35	2
Nausea	15	0	29	0

Table 1: Adverse Events Reported in $\geq 5\%$ of Patients with Newly Diagnosed Chronic Phase CML - 60 month follow up

SYSTEM ORGAN CLASS/ Preferred Term	SPRYCEL 100 mg QD (n=258)		Imatinib 400 mg QD (n=258)	
	All Grades	Grade 3/4	All Grades	Grade 3/4
	Percent (%) of Patients			
Abdominal pain	22	1	17	<1
Vomiting	17	<1	21	<1
Dyspepsia	11	0	12	0
Gastritis	10	<1	7	0
Mucosal inflammation (including mucositis/stomatitis)	9	<1	5	0
Constipation	8	0	3	0
Abdominal Distension	6	0	4	0
Ascites*	0	0	<1	0
INFECTIONS AND INFESTATIONS				
Upper respiratory tract infection/inflammation	38	1	38	1
Infection (including bacterial, viral, fungal, non-specified)	40	4	30	3
Enterocolitis infection	11	0	6	<1
MUSCULOSKELETAL AND CONNECTIVE TISSUE DISORDERS				
Musculoskeletal pain	31	<1	34	<1
Muscle spasms	5	0	24	<1
Myalgia	14	<1	16	0
Arthralgia	14	0	16	<1
SKIN AND SUBCUTANEOUS TISSUE DISORDERS				
Rash ^a	20	0	23	2
Pruritus	7	0	9	<1
Dermatitis including eczema	4	0	7	0
Pigmentation disorder	2	0	7	0
Acne	6	0	2	0
Hyperhidrosis	2	0	5	0
RESPIRATORY, THORACIC AND MEDIASTINAL DISORDERS				
Cough	27	<1	11	0
Pleural effusion	29	3	1	0
Dyspnea	16	2	6	0
Pulmonary hypertension	5	1	<1	0
Pulmonary edema*	1	0	0	0

Table 1: Adverse Events Reported in $\geq 5\%$ of Patients with Newly Diagnosed Chronic Phase CML - 60 month follow up

SYSTEM ORGAN CLASS/ Preferred Term	SPRYCEL 100 mg QD (n=258)		Imatinib 400 mg QD (n=258)	
	All Grades	Grade 3/4	All Grades	Grade 3/4
	Percent (%) of Patients			
NERVOUS SYSTEM DISORDERS				
Headache	23	0	18	<1
Neuropathy (including peripheral)	10	<1	8	<1
Dizziness	11	<1	7	<1
VASCULAR DISORDERS				
Hemorrhage	19	2	18	2
Other bleeding ^b	14	<1	15	2
Gastrointestinal bleeding	5	1	4	<1
CNS bleeding*	1	<1	<1	<1
Hypertension	11	<1	8	<1
INVESTIGATIONS				
Weight increased	10	2	13	3
CARDIAC DISORDERS				
Congestive heart failure/ cardiac dysfunction ^{c, *}	4	1	2	1
Pericardial effusion	5	1	2	0
PSYCHIATRIC DISORDERS				
Insomnia	8	0	6	0
Depression	2	0	5	<1
METABOLISM AND NUTRITION DISORDERS				
Appetite disturbances	9	0	5	0
EYE DISORDERS				
Conjunctivitis	4	0	7	0

^a Includes erythema, erythema multiforme, heat rash, rash, rash erythematous, rash generalized, rash macular, rash papular, rash pustular, skin exfoliation, and rash vesicular.

^b Includes conjunctival hemorrhage, ear hemorrhage, ecchymosis, epistaxis, eye hemorrhage, gingival bleeding, hematoma, hematuria, hemoptysis, hemorrhage, hemorrhage subcutaneous, intra-abdominal hematoma, menorrhagia, metrorrhagia, petechiae, scleral hemorrhage, uterine hemorrhage, and vaginal hemorrhage.

^c Includes cardiac failure, cardiac failure acute, cardiac failure congestive, cardiomyopathy, diastolic dysfunction, ejection fraction decreased, and left ventricular dysfunction.

* Adverse events of special interest with <5% frequency.

Patients with imatinib intolerant or resistant CML or Ph+ ALL

All treatment-emergent adverse events (excluding laboratory abnormalities), regardless of relationship to study drug, that were reported in at least 5% of the patients treated with SPRYCEL at the recommended dose of 100 mg once daily in a Phase III clinical study of imatinib intolerant or resistant chronic phase CML are shown in Table 2.

In the Phase III dose-optimization study in patients with imatinib intolerant or resistant chronic phase CML, the median overall duration of therapy with 100 mg once daily was 30 months (range 1-93 months).

Table 2: Adverse Events Reported in ≥5% of Patients treated with 100 mg Once Daily dose in Clinical Studies of Imatinib Intolerant or Resistant Chronic Phase CML - 84 month follow up

SYSTEM ORGAN CLASS/ Preferred Term	Phase III	
	100 mg QD n=165	
	Percent (%) of Patients	
	All Grades	Grade 3/4
GENERAL DISORDERS AND ADMINISTRATION SITE CONDITIONS		
Superficial edema ^a	26	1
Fatigue	37	4
Pain	27	1
Pyrexia	21	1
Chest pain	17	2
Asthenia	9	1
Chills	7	0
Generalized edema	5	1
GASTROINTESTINAL DISORDERS		
Diarrhea	42	4
Abdominal pain	24	2
Nausea	22	1
Constipation	18	2
Vomiting	14	1
Abdominal distension	12	0
Mucosal inflammation (including mucositis/stomatitis)	10	0
Dyspepsia	8	0
Ascites ^b	1	0
INFECTIONS AND INFESTATIONS		
Infection (including bacterial, viral, fungal, non-specified)	48	6

Table 2: Adverse Events Reported in $\geq 5\%$ of Patients treated with 100 mg Once Daily dose in Clinical Studies of Imatinib Intolerant or Resistant Chronic Phase CML - 84 month follow up

SYSTEM ORGAN CLASS/ Preferred Term	Phase III	
	100 mg QD n=165	
	Percent (%) of Patients	
	All Grades	Grade 3/4
Upper respiratory tract infection/inflammation	43	1
Pneumonia (including bacterial, viral, and fungal)	13	5
Enterocolitis infection	7	2
Herpes virus infection	5	1
MUSCULOSKELETAL AND CONNECTIVE TISSUE DISORDERS		
Musculoskeletal pain	48	3
Arthralgia	30	2
Myalgia	17	0
Muscle spasms	6	0
Arthritis	5	0
SKIN AND SUBCUTANEOUS TISSUE DISORDERS		
Skin rash	33	2
Pruritus	17	1
Hyperhidrosis	10	0
Alopecia	8	0
Dry skin	6	0
Acne	5	0
RESPIRATORY, THORACIC AND MEDIASTINAL DISORDERS		
Dyspnea	34	2
Cough	34	1
Pleural effusion	28	5
Pulmonary edema ^b	1	0
Pulmonary hypertension ^b	2	1
NERVOUS SYSTEM DISORDERS		
Headache	48	1
Dizziness	16	2
Neuropathy (including peripheral neuropathy)	14	1
VASCULAR DISORDERS		

Table 2: Adverse Events Reported in $\geq 5\%$ of Patients treated with 100 mg Once Daily dose in Clinical Studies of Imatinib Intolerant or Resistant Chronic Phase CML - 84 month follow up

SYSTEM ORGAN CLASS/ Preferred Term	Phase III	
	100 mg QD n=165	
	Percent (%) of Patients	
	All Grades	Grade 3/4
Hemorrhage	27	3
Gastrointestinal bleeding	6	1
CNS bleeding	0	0
Hypertension	9	0
Flushing	6	0
INVESTIGATIONS		
Weight increased	11	1
Weight decreased	8	0
CARDIAC DISORDERS		
Arrhythmia (including tachycardia)	8	0
Palpitations	8	0
Congestive heart failure/cardiac dysfunction ^{b, c}	2	1
Pericardial effusion ^b	3	1
PSYCHIATRIC DISORDERS		
Insomnia	12	0
Depression	11	1
Anxiety	5	0
METABOLISM AND NUTRITION DISORDERS		
Appetite Disturbances	10	0
Hyperuricemia	5	1
EYE DISORDERS		
Visual disorder	7	0
RENAL AND URINARY DISORDERS		
Urinary frequency	7	1
IMMUNE SYSTEM DISORDERS		
Hypersensitivity (including erythema nodosum)	5	1

^a Superficial edema is a grouped term composed of face edema, other superficial edema, and peripheral edema

^b Adverse events of special interest with $<5\%$ frequency.

c Includes ventricular dysfunction, cardiac failure, cardiac failure congestive, cardiomyopathy, congestive cardiomyopathy, diastolic dysfunction, ejection fraction decreased and ventricular failure

With a minimum follow-up of 84 months, long-term cumulative safety data are available for the 100 mg once daily dose. Due to the allowance of switching to the 100 mg once daily dosing in the other three arms of the trial, safety results of these treatment groups are similar to the 100 mg once daily dose. Adverse events (all grades) that continued to occur in patients treated on the 100 mg once daily schedule at 2 and 7 years included: overall fluid retention (34% vs. 48%), pleural effusion (18% vs. 28%), and superficial edema (18% vs. 22%). Grade 3 or 4 pleural effusion among patients treated with 100 mg once daily at 2 and 7 years was 2% vs. 5%, respectively.

In the Phase III dose-optimization study exploring the once daily schedule of SPRYCEL (140 mg once daily) in patients with imatinib intolerant or resistant advanced diseases, the median duration of therapy was 13.62 months (range .03–31.15 months) for accelerated phase CML, 3.19 months (range .03–27.73 months) for myeloid blast CML, 3.55 months (range .10–22.08 months) for lymphoid blast CML, and 2.99 months (range .16–23.46 months) for Ph+ ALL.

Table 3: Adverse Events Reported in ≥5% of Patients treated with 140 mg daily dose in Clinical Studies of Imatinib Intolerant or Resistant Advanced Phase CML and Ph+ ALL

SYSTEM ORGAN CLASS/ Preferred Term	Phase III	
	140 mg QD	
	n = 304	
	Percent (%) of Patients	
	All Grades	Grade 3/4
GENERAL DISORDERS AND ADMINISTRATION SITE CONDITIONS		
Superficial edema ^a	25	<1
Pyrexia	39	3
Fatigue	29	5
Pain	24	2
Asthenia	13	3
Chest pain	13	1
Generalised oedema ^b	3	<1
GASTROINTESTINAL DISORDERS		
Diarrhea	44	6
Nausea	34	2
Vomiting	28	1
Abdominal pain	20	4
Mucosal inflammation (including mucositis/stomatitis)	17	1
Constipation	15	1
Dyspepsia	9	0

Table 3: Adverse Events Reported in $\geq 5\%$ of Patients treated with 140 mg daily dose in Clinical Studies of Imatinib Intolerant or Resistant Advanced Phase CML and Ph+ ALL

SYSTEM ORGAN CLASS/ Preferred Term	Phase III	
	140 mg QD n = 304	
	Percent (%) of Patients	
	All Grades	Grade 3/4
Ascites ^b	<1	<1
INFECTIONS AND INFESTATIONS		
Infection	46	14
Upper respiratory tract infection/inflammation	26	1
Pneumonia (including bacterial, viral, and fungal)	17	9
Sepsis (including fatal outcomes)	6	4
Enterocolitis infection	5	1
MUSCULOSKELETAL AND CONNECTIVE TISSUE DISORDERS		
Musculoskeletal pain	38	7
Arthralgia	20	2
Myalgia	11	1
SKIN AND SUBCUTANEOUS TISSUE DISORDERS		
Skin Rash	27	1
Hyperhidrosis	9	0
Pruritus	10	0
Dry skin	6	0
RESPIRATORY, THORACIC AND MEDIASTINAL DISORDERS		
Dyspnea	28	6
Cough	29	0
Pleural Effusion	28	8
Lung infiltration	5	2
Pulmonary oedema ^b	2	1
Pulmonary hypertension ^b	1	1
NERVOUS SYSTEM DISORDERS		
Headache	37	4
Neuropathy (including peripheral neuropathy)	14	1
Dizziness	9	1

Table 3: Adverse Events Reported in ≥5% of Patients treated with 140 mg daily dose in Clinical Studies of Imatinib Intolerant or Resistant Advanced Phase CML and Ph+ ALL

SYSTEM ORGAN CLASS/ Preferred Term	Phase III	
	140 mg QD n = 304	
	Percent (%) of Patients	
	All Grades	Grade 3/4
VASCULAR DISORDERS		
Hemorrhage	44	13
Gastrointestinal bleeding	17	9
CNS bleeding ^b	5	1
Hypertension	8	1
Hypotension	6	2
INVESTIGATIONS		
Weight decreased	17	1
Weight increased	11	1
CARDIAC DISORDERS		
Arrhythmia (including tachycardia)	13	1
Congestive heart failure/ cardiac dysfunction ^{b, c}	3	1
Pericardial effusion ^b	2	1
PSYCHIATRIC DISORDERS		
Depression	8	0
Insomnia	6	0
Anxiety	6	1
METABOLISM AND NUTRITION DISORDERS		
Appetite Disturbances	17	1
RENAL AND URINARY DISORDERS		
Renal failure	6	5
BLOOD AND LYMPHATIC SYSTEM DISORDERS		
Febrile neutropenia	12	12
INJURY, POISONING AND PROCEDURAL		
Contusion	6	<1

a Superficial edema is a grouped term composed of face edema, other superficial edema, and peripheral edema

b Adverse events of special interest with <5% frequency.

c Includes ventricular dysfunction, cardiac failure, cardiac failure congestive, cardiomyopathy, congestive cardiomyopathy, diastolic dysfunction, ejection fraction decreased, and ventricular failure.

Less Common Clinical Trial Adverse Drug Reactions (<5% all grades) reported in Clinical Trials in patients treated with SPRYCEL

The following additional adverse reactions, regardless of relationship to therapy or dosing regimen, were reported in patients in the SPRYCEL clinical studies (n = 2,712) at a frequency of <5%, unless otherwise noted. These reactions are presented by frequency category. Frequent reactions are those occurring in $\geq 1\%$ of patients, infrequent reactions are those occurring in 0.1% – <1% of patients and rare reactions are those occurring in <0.1% of patients. These events are included based on clinical relevance.

Blood and Lymphatic System Disorders: *Frequent:* myelosuppression (including anemia, neutropenia, thrombocytopenia); *Infrequent:* coagulopathy, lymphadenopathy, lymphopenia; *Rare:* aplasia pure red cell, splenic calcification.

Cardiac Disorders: *Frequent:* angina pectoris, cardiomegaly, myocardial infarction (including fatal outcomes) *Infrequent:* electrocardiogram QT prolonged, pericarditis, ventricular arrhythmia (including ventricular tachycardia), acute coronary syndrome, cor pulmonale myocarditis, electrocardiogram T wave abnormal, troponin increased, cardiac arrest, coronary artery disease; *Rare:* arteriosclerosis coronary artery, restrictive cardiomyopathy, electrocardiogram PR prolongation, pleuropericarditis.

Congenital, Familial and Genetic Disorders: *Rare:* porokeratosis.

Ear and Labyrinth Disorders: *Frequent:* tinnitus, vertigo, hearing loss.

Endocrine Disorders: *Frequent:* hypothyroidism; *Infrequent:* hyperthyroidism, thyroiditis.

Eye Disorders: *Frequent:* conjunctivitis, dry eye, visual disorder; *Infrequent:* visual impairment, lacrimation increased; *Rare:* pterygium, retinal vascular disorder, photophobia.

Gastrointestinal Disorders: *Frequent:* dysphagia, gastroesophageal reflux disease, colitis (including neutropenic colitis), oral soft tissue disorder; *Infrequent:* anal fissure, esophagitis, anal fistula, upper gastrointestinal ulcer, pancreatitis, ileus; *Rare:* protein-losing gastroenteropathy, volvulus, pancreatitis acute.

General Disorders and Administration Site Conditions: *Frequent:* malaise, face edema (>5%), other superficial edema; *Rare:* gait disturbance.

Hepatobiliary Disorders: *Infrequent:* cholecystitis, cholestasis, hepatitis; *Rare:* acquired dilatation intrahepatic duct.

Immune System Disorders: *Rare:* anaphylactic reaction.

Infections and Infestations: *Rare:* sialoadenitis

Injury, Poisoning and Procedural Complications: *Rare:* epicondylitis

Investigations: *Infrequent:* blood creatine phosphokinase increased, gamma-glutamyltransferase increased; *Rare:* clostridium test positive, coxsackie virus test positive, hepatitis C RNA increased, platelet aggregation abnormal, blood chloride increased.

Metabolism and Nutrition Disorders: *Frequent:* dehydration; *Infrequent:* hypoalbuminemia, diabetes mellitus, tumour lysis syndrome, hypercholesterolemia.

Musculoskeletal and Connective Tissue Disorders: *Frequent:* muscular weakness, musculoskeletal stiffness; *Infrequent:* tendonitis, rhabdomyolysis, muscle inflammation, osteonecrosis; *Rare:* chondrocalcinosis, osteochondrosis, gouty tophus.

Neoplasms Benign, Malignant and Unspecified: *Rare:* oral papilloma.

Nervous System Disorders: *Frequent:* dysgeusia, syncope, amnesia, tremor, convulsion, somnolence; *Infrequent:* cerebrovascular accident, transient ischemic attack, balance disorder, ataxia; *Rare:* VIIth nerve paralysis, cerebellar infarction, dementia, reversible posterior encephalopathy syndrome, optic neuritis, carotid artery stenosis.

Pregnancy, Puerperium and Perinatal Conditions: *Rare:* abortion

Psychiatric Disorders: *Frequent:* confusional state, affect lability; *Infrequent:* libido decreased; *Rare:* hypomania, seasonal affective disorder.

Renal and Urinary Disorders: *Infrequent:* proteinuria, renal impairment; *Rare:* nephrocalcinosis, bladder diverticulum, glomerulonephritis.

Reproductive System and Breast Disorders: *Frequent:* gynecomastia; *Infrequent:* menstrual disorder; *Rare:* orchitis non-infective, vaginal prolapse.

Respiratory, Thoracic, and Mediastinal Disorders: *Frequent:* asthma, lung infiltration, dysphonia, pneumonitis; *Infrequent:* bronchospasm, acute respiratory distress syndrome (including fatal outcomes), pulmonary embolism, oropharyngeal discomfort; *Rare:* pulmonary arterial hypertension, nasal septum deviation, rhinitis hypertrophic, reflux laryngitis, nasal septum perforation.

Skin and Subcutaneous Tissue Disorders: *Frequent:* urticaria, skin ulcer, photosensitivity; *Infrequent:* bullous conditions, nail disorder, neutrophilic dermatosis, palmar-plantar erythrodysesthesia syndrome, panniculitis, hair disorder; *Rare:* asteatosis, leukocytoclastic vasculitis, skin fibrosis.

Vascular Disorders: *Frequent:* thrombophlebitis; *Infrequent:* deep vein thrombosis, thrombosis, atherosclerosis; *Rare:* livedo reticularis, peripheral arterial occlusive disease, arterial occlusive disease, embolism, cerebral arteriosclerosis.

Abnormal Hematologic and Clinical Chemistry Findings

Myelosuppression was commonly reported in all studies. However, the frequency of Grade 3 or 4 neutropenia, thrombocytopenia, and anemia was higher in patients with advanced phase CML or Ph+ ALL than in chronic phase CML. Most patients continued treatment without further progressive myelosuppression.

Newly diagnosed patients with chronic phase CML

Laboratory abnormalities reported in patients treated with SPRYCEL in the Phase III clinical study in patients with newly diagnosed CML are shown in Table 4. Myelosuppression was less frequently reported in newly diagnosed chronic phase CML, than in chronic phase CML patients with resistance or intolerance to prior imatinib therapy. In SPRYCEL-treated patients who experienced grade 3 or 4 myelosuppression, recovery generally occurred following brief dose interruptions and/or reductions and permanent discontinuation of treatment occurred in 2.3% of patients due to drug-related hematologic toxicities.

Table 4: CTC Grade 3/4 Laboratory Abnormalities in Patients with Newly Diagnosed Chronic Phase CML 60-month follow up

	SPRYCEL (n=258)	Imatinib (n=258)
Percent (%) of Patients		
Hematology Parameters		
Neutropenia	29	24
Thrombocytopenia	22	14
Anemia	13	9
Biochemistry Parameters		
Elevated Alkaline phosphatase	1	0
Hyperuricemia	4	1
Hypophosphatemia	7	31
Hypokalemia	0	3
Hypocalcemia	4	3
Hypomagnesemia	<1	2
Hyponatremia	3	2
Elevated SGPT (ALT)	<1	2
Elevated SGOT (AST)	<1	1
Elevated Bilirubin	1	0
Elevated Creatinine	1	1

CTC grades: neutropenia (Grade 3 ≥ 0.5 – $<1.0 \times 10^9/L$, Grade 4 $<0.5 \times 10^9/L$); thrombocytopenia (Grade 3 ≥ 25 – $<50 \times 10^9/L$, Grade 4 $<25 \times 10^9/L$); anemia (hemoglobin Grade 3 ≥ 65 – <80 g/L, Grade 4 <65 g/L); elevated creatinine (Grade 3 >3 – $6 \times$ upper limit of normal range (ULN), Grade 4 $>6 \times$ ULN); elevated bilirubin (Grade 3 >3 – $10 \times$ ULN, Grade 4 $>10 \times$ ULN); elevated SGOT or SGPT (Grade 3 >5 – $20 \times$ ULN, Grade 4 $>20 \times$ ULN); hypocalcemia (Grade 3 <7.0 – 6.0 mg/dL, Grade 4 <6.0 mg/dL); hypophosphatemia (Grade 3 <2.0 – 1.0 mg/dL, Grade 4 <1.0 mg/dL); hypokalemia (Grade 3 <3.0 – 2.5 mmol/L, Grade 4 <2.5 mmol/L).

Patients with imatinib intolerant or resistant CML or Ph+ ALL

Laboratory abnormalities that were reported in patients treated with SPRYCEL in clinical studies are shown in Table 5 for imatinib intolerant or resistant chronic or advanced phase CML and Ph+ ALL.

In patients who experienced severe myelosuppression, recovery generally occurred following brief dose interruptions and/or reductions. Occasionally permanent discontinuation of treatment was required.

Elevations of transaminases or bilirubin were reported in all disease phases, but were more common in patients with advanced disease. The numbers of patients who developed three or more simultaneous significant elevations of transaminases or bilirubin suggestive of hepatic toxicity were as follows: Chronic phase, 4; accelerated, 13; myeloid blast, 13; lymphoid blast, 7. Most events were managed with dose reduction or interruption. One patient required discontinuation of treatment due to abnormalities of liver function tests. Although causality has not been established, the occurrence of abnormal liver function tests on treatment should be followed closely and consideration given to discontinuing SPRYCEL.

Hypocalcemia:

Between 48% and 76% of patients experienced hypocalcemia at least once during this period. Grade 3 or 4 abnormalities were reported in 2, 7, 16, 13 and 9% of the patients in the chronic phase CML (n=1150), accelerated phase CML (n=502), myeloid blast phase CML (n=280), lymphoid blast phase CML (n=115) and Ph+ ALL (n=135), respectively. The percentage of patients with hypocalcemia who were treated with calcium supplements is 7% for chronic phase CML, 16% for accelerated phase CML, 28% for myeloid blast CML, 20% for lymphoid blast CML and 20% for Ph+ ALL.

Hypophosphatemia:

Between 41% and 50% of patients experienced hypophosphatemia at least once during this period. Grade 3 or 4 abnormalities were reported in 10, 13, 20, 19 and 21% of the patients in the chronic phase CML (n=1150), accelerated phase CML (n=502), myeloid blast phase CML (n=280), lymphoid blast phase CML (n=115) and Ph+ ALL (n=135), respectively.

In the Phase II randomized study, the frequency of Grade 3 or 4 neutropenia, thrombocytopenia, and anemia was 63%, 57%, and 20%, respectively, in the SPRYCEL group and 39%, 14%, and 8%, respectively, in the imatinib group. The frequency of Grade 3 or 4 hypocalcemia was 5% in the SPRYCEL group and 0% in the imatinib group.

Table 5: CTC Grades 3/4 Laboratory Abnormalities in Clinical Studies of CML: Patients with imatinib Resistant or Intolerant chronic phase CML, advanced phase CML or Ph+ ALL ^a

	Chronic Phase ^b n=165	Accelerated Phase ^c n=157	Myeloid Blast Phase ^c n=74	Lymphoid Blast Phase ^c n=33	Ph+ ALL ^c n=40
Percent (%) of Patients					
Hematology Parameters*					
Neutropenia	35	58	77	79	67
Thrombocytopenia	23	63	78	85	72
Anemia	13	47	74	52	36
Biochemistry Parameters					
Hypophosphatemia	10	13	12	18	16
Hypokalemia	2	7	11	15	8
Hypocalcemia	<1	4	9	12	5
Elevated SGPT (ALT)	0	2	5	3	8
Elevated SGOT (AST)	<1	0	4	3	3
Elevated Bilirubin	<1	1	3	6	3
Elevated Creatinine	0	2	8	0	0

^a Phase III dose optimization study results reported at 2-year study follow up

^b CA180-034 study results at recommended starting dose of 100 mg once daily

^c CA180-035 study results at recommended starting dose of 140 mg once daily

Post-Market Adverse Drug Reactions

The following additional adverse reactions have been identified during post approval use of SPRYCEL. Because these reactions are reported voluntarily from a population of uncertain size, it is not always possible to reliably estimate their frequency or establish a causal relationship to drug exposure.

Infections and infestations	hepatitis B reactivation
Cardiac disorders:	Atrial fibrillation/atrial flutter ^a
Respiratory, thoracic and mediastinal disorders:	Interstitial lung disease, pulmonary arterial hypertension ^b
Pregnancy disorders:	Fetal complications (including hydrops fetalis and fetal malformations)
Skin and subcutaneous tissue disorders:	Stevens-Johnson syndrome ^c
Renal and urinary disorders:	Nephrotic syndrome
Vascular disorders	Thrombotic microangiopathy (TMA)

- a. Typically reported in elderly patients or in patients with confounding factors including significant underlying or concurrent cardiac or cardiovascular disorders, or other significant comorbidities (eg, severe infection/sepsis, electrolyte abnormalities).
- b. Some patients with PAH reported during SPRYCEL treatment were taking concomitant medications or had comorbidities in addition to the underlying malignancy.
- c. In the post-marketing setting, individual cases of Stevens-Johnson syndrome have been reported. It could not be determined whether these mucocutaneous adverse reactions were directly related to SPRYCEL or to concomitant medications.

DRUG INTERACTIONS

Overview

Dasatinib is an inhibitor of CYP3A4 and may decrease the metabolic clearance of drugs that are primarily metabolized by CYP3A4. At clinically relevant concentrations, dasatinib does not inhibit CYP 1A2, 2A6, 2B6, 2C8, 2C9, 2C19, 2D6, or 2E1. Dasatinib is not an inducer of CYP enzymes.

Drug-Drug Interactions

Drugs that may increase dasatinib plasma concentrations

CYP3A4 Inhibitors: In vitro studies indicate that dasatinib is a CYP3A4 substrate. In a study of 18 patients with solid tumors, 20-mg SPRYCEL once daily coadministered with 200 mg of ketoconazole BID increased the dasatinib C_{max} and AUC by four- and five-fold, respectively. Substances that inhibit CYP3A4 activity (eg, ketoconazole, itraconazole, erythromycin, clarithromycin, grapefruit juice) may decrease metabolism and increase concentrations of dasatinib and should be avoided. Selection of an alternate concomitant medication with no or minimal CYP3A4 inhibition potential is recommended. If systemic administration of a potent CYP3A4 inhibitor cannot be avoided, a dose reduction should be considered and the patient should be closely monitored for toxicity (see WARNINGS AND PRECAUTIONS: Drug-Drug Interactions, DRUG INTERACTIONS: Drug-Food Interactions and DOSAGE AND ADMINISTRATION).

Drugs that may decrease dasatinib plasma concentrations

CYP3A4 Inducers: Data from a study of 20 healthy subjects indicate that when a single morning dose of SPRYCEL was administered following 8 days of continuous evening administration of 600 mg of rifampicin, a potent CYP3A4 inducer, the mean C_{max} and AUC of dasatinib were decreased by 81% and 82%, respectively. In addition, more healthy male subjects experienced increases in QTcF of > 30msec from the baseline recordings when a single dose of dasatinib was administered 12 hours following rifampicin compared to when dasatinib was given alone (25% vs. 10%, n = 20). No subject experienced QTcF > 450 msec or a change from baseline > 60 msec (see WARNINGS AND PRECAUTIONS: Cardiovascular, Drug-Drug Interactions and TOXICOLOGY: Safety Pharmacology).

Antacids: Nonclinical data indicate that dasatinib has pH dependent solubility. In a study of 24 healthy subjects, administration of 30 mL of aluminum hydroxide/magnesium hydroxide

2 hours prior to a single 50 mg dose of SPRYCEL was associated with no relevant change in dasatinib AUC or C_{max}. On the contrary, when 30 mL of aluminum hydroxide/magnesium hydroxide was administered to the same subjects concomitantly with a 50 mg dose of SPRYCEL, a 55% reduction in dasatinib AUC and a 58% reduction in C_{max} were observed (See WARNINGS AND PRECAUTIONS: Drug-Drug Interactions).

Famotidine: In a study of 24 healthy subjects, administration of a single 50 mg dose of SPRYCEL 10 hours following famotidine reduced the AUC and C_{max} of SPRYCEL by 61% and 63%, respectively (See WARNINGS AND PRECAUTIONS: Drug-Drug Interactions).

Drugs that may have their plasma concentration altered by dasatinib

CYP3A4 Substrates: Single dose data from a study of 54 healthy subjects indicate that the mean C_{max} and AUC of simvastatin, a prototypical CYP3A4 substrate, were increased by 37% and 20%, respectively, when simvastatin (80 mg) was administered in combination with a single 100 mg dose of SPRYCEL. In addition, three healthy subjects (n = 48) experienced QTcF of > 30 msec from the baseline ECG recordings following the concomitant use of a single dose of simvastatin and dasatinib. No subject experienced QTcF > 450 msec or a change from baseline > 60 msec. The effect of CYP3A4 substrates on the pharmacokinetics of dasatinib has not been studied (See WARNINGS AND PRECAUTIONS: Cardiovascular, Drug-Drug Interactions).

Drugs that prolong QTc interval or induce torsades de pointes

The concomitant use of SPRYCEL with medicinal products known to prolong QTc interval or medicinal products able to induce torsades de pointes should be avoided if possible. Medicinal products that are generally accepted to carry the risk of QT prolongation and torsades de pointes include but are not limited to the examples that follow: Class IA (e.g. disopyramide, procainamide), Class III (e.g. amiodarone, sotalol, ibutilide), or Class IC (e.g. flecainide), antiarrhythmic medicinal products, antipsychotics (e.g. chlorpromazine, haloperidol, pimozide), opioids (e.g. methadone), macrolide antibiotics (e.g. erythromycin, clarithromycin, quinolone antibiotics (e.g. moxifloxacin), antimalarials (e.g. chloroquine), GI stimulants or others (e.g. domperidone).

Drug-Food Interactions

SPRYCEL should not be taken with grapefruit or grapefruit juice.

Drug-Herb Interactions

Concomitant use of dasatinib and St John's Wort (*Hypericum perforatum*) may substantially reduce exposure to dasatinib.

DOSAGE AND ADMINISTRATION

Recommended Starting Dose

- The recommended starting dosage of SPRYCEL (dasatinib) for chronic phase CML is 100 mg administered orally once daily (OD), either in the morning or in the evening.
- The recommended starting dosage of SPRYCEL for accelerated phase CML, or myeloid or lymphoid blast CML, is 140 mg/day administered orally once daily (140 mg QD) either in the morning or in the evening.
- The recommended starting dosage of SPRYCEL for Ph+ ALL is 140 mg administered orally once daily (140 mg QD) either in the morning or in the evening.

Dosing recommendations in patients with imatinib resistant or intolerant CML and Ph+ ALL are based on the results of two randomized Phase III dose-optimization studies (see CLINICAL TRIALS section).

SPRYCEL can be taken with or without food. Tablets should not be crushed or cut; they should be swallowed whole.

In clinical studies, treatment with SPRYCEL was continued until disease progression or until no longer tolerated by the patient. The effect of stopping treatment on long-term disease outcome after the achievement of a complete cytogenetic response ([CCyR]) or major molecular response (MMR) has not been investigated.

Dose Escalation

In clinical studies of adult CML and Ph+ ALL patients, dose escalation to 140 mg once daily (chronic phase CML) or 180 mg once daily (advanced phase CML and Ph+ ALL) was allowed in patients who did not achieve a hematologic or cytogenetic response at the recommended dosage.

Dose reduction for concomitant use of strong CYP3A4 inhibitors

The concomitant use of strong CYP3A4 inhibitors and grapefruit juice with SPRYCEL should be avoided (see DRUG INTERACTIONS: Drug-Drug Interactions and Drug-Food Interactions). CYP3A4 inhibitors such as ketoconazole may increase SPRYCEL plasma concentrations. If possible, an alternative concomitant medication with no or minimal enzyme inhibition potential should be selected. If SPRYCEL must be administered with a strong CYP3A4 inhibitor, consider a dose decrease to:

40 mg daily for patients taking SPRYCEL 140 mg daily.

20 mg daily for patients taking SPRYCEL 100 mg daily.

20 mg daily for patients taking SPRYCEL 70 mg daily.

For patients taking SPRYCEL 60 mg or 40 mg daily, consider interrupting SPRYCEL until the inhibitor is discontinued. Allow a washout period of approximately 1 week after the inhibitor is stopped before reinitiating SPRYCEL.

The reduced doses of SPRYCEL are predicted to adjust the area under the curve (AUC) to the range observed without CYP3A4 inhibitors; however, clinical data are not available with these dose adjustments in patients receiving strong CYP3A4 inhibitors. If SPRYCEL is not tolerated after dose reduction, either discontinue the strong CYP3A4 inhibitor or stop SPRYCEL until the inhibitor is discontinued. Allow a washout period of approximately 1 week after the inhibitor is stopped before the SPRYCEL dose is increased.

Dose Adjustment for Adverse Reactions

Myelosuppression

In clinical studies, myelosuppression was managed by dose interruption, dose reduction, or discontinuation of study therapy. Hematopoietic growth factor has been used in patients with resistant myelosuppression. Guidelines for dose modifications are summarized in Table 6.

Table 6: Dose Adjustments for Neutropenia and Thrombocytopenia

<p>Chronic Phase CML (starting dose 100 mg once daily)</p>	<p>ANC* $<0.5 \times 10^9/L$ and/or Platelets $<50 \times 10^9/L$</p>	<ol style="list-style-type: none"> 1. Stop SPRYCEL until ANC $\geq 1.0 \times 10^9/L$ and platelets $\geq 50 \times 10^9/L$. 2. Resume treatment with SPRYCEL at the original starting dose. 3. If platelets $<25 \times 10^9/L$ and/or recurrence of ANC $<0.5 \times 10^9/L$ for >7 days, repeat Step 1 and resume SPRYCEL at a reduced dose of 80 mg once daily for second episode. For third episode, further reduce dose to 50 mg once daily (for newly diagnosed patients) or discontinue SPRYCEL (for patients resistant or intolerant to prior therapy including imatinib).
<p>Accelerated Phase CML, Blast Phase CML and Ph+ ALL (starting dose 140 mg once daily)</p>	<p>ANC* $<0.5 \times 10^9/L$ and/or Platelets $<10 \times 10^9/L$</p>	<ol style="list-style-type: none"> 1. Check if cytopenia is related to leukemia (marrow aspirate or biopsy). 2. If cytopenia is unrelated to leukemia, stop SPRYCEL until ANC $\geq 1.0 \times 10^9/L$ and platelets $\geq 20 \times 10^9/L$ and resume at the original starting dose. 3. If recurrence of cytopenia, repeat Step 1 and resume SPRYCEL at a reduced dose of 100 mg once daily (second episode) or 80 mg once daily (third episode). 4. If cytopenia is related to leukemia, consider dose escalation to 180 mg once daily.

*ANC: absolute neutrophil count

Non-hematological adverse reactions

If a moderate (Grade 2) non-hematological adverse reaction develops with SPRYCEL, treatment should be interrupted until the adverse reaction has resolved or returned to baseline. The same dose should be resumed if this is the first occurrence and the dose should be reduced if this is a recurrent adverse reaction.

If a severe (Grade 3 or 4) non-hematological adverse reaction develops with SPRYCEL use, treatment must be withheld until the event has resolved or improved. Thereafter, treatment can be resumed as appropriate at a reduced dose depending on the initial severity of the event. However, in patients diagnosed with pulmonary arterial hypertension (PAH), SPRYCEL should be permanently discontinued.

Patients with chronic CML who received 100 mg once daily, dose reduction to 80 mg once daily with further reduction from 80 mg once daily to 50 mg once daily, if needed, is recommended. For adult patients with advanced phase CML or Ph+ ALL who received 140 mg once daily, dose reduction to 100 mg once daily with further reduction from 100 mg once daily to 80 mg once daily, if needed, is recommended.

Pediatrics (< 18 years of age): SPRYCEL is not recommended for use in children below 18 years of age due to a lack of data on safety and efficacy.

Hepatic impairment:

No clinical pharmacokinetic trials were conducted with a 70-100 mg dose of SPRYCEL in patients with decreased liver function. SPRYCEL should be used with caution in patients with moderate to severe hepatic impairment (see WARNINGS AND PRECAUTIONS).

Renal impairment:

No clinical trials were conducted with SPRYCEL in patients with decreased renal function (trials excluded patients with serum creatinine concentration > 1.5 times the upper limit of the normal range). Since the renal clearance of dasatinib and its metabolites is < 4%, a decrease in total body clearance is not expected in patients with renal insufficiency.

OVERDOSAGE

For management of a suspected drug overdose, please contact your regional Poison Control Centre.

Experience with overdose of SPRYCEL in clinical studies is limited to isolated cases. The highest reported dosage ingested was 280 mg per day for 1 week in two patients and both developed a significant decrease in platelet counts. Since SPRYCEL is associated with severe myelosuppression (see Warnings and Precautions and Adverse Reactions), patients who ingested more than the recommended dosage should be closely monitored for myelosuppression and appropriate supportive treatment given.

ACTION AND CLINICAL PHARMACOLOGY

Mechanism of Action

Dasatinib inhibits the activity of the BCR-ABL kinase and SRC family kinases (LYN, HCK), along with a number of other kinases including c-KIT, ephrin (EPH) receptor kinases, and PDGF β receptor. Dasatinib is a potent inhibitor of the BCR-ABL and SRC family kinases with potency at sub-nanomolar concentrations. It binds not only to the inactive but also to the active conformation of the enzyme.

Pharmacodynamics

In vitro, dasatinib is active in leukemic cell lines representing variants of imatinib sensitive and resistant disease. These nonclinical studies show that dasatinib can overcome imatinib resistance resulting from BCR-ABL overexpression, BCR-ABL kinase domain mutations (14/15 mutations with exception of T315I), activation of alternate signaling pathways involving the SRC family kinases (LYN, HCK), and multidrug resistance gene, *MDR1*, overexpression.

In vivo, in separate experiments using murine models of CML, dasatinib prevented the progression of chronic CML to blast phase and prolonged the survival of mice bearing patient-derived CML cell lines (see DETAILED PHARMACOLOGY).

Electrocardiogram: In five Phase II clinical studies in patients with leukemia, repeated baseline and on-treatment ECGs were obtained at pre-specified time points and read centrally for 865 patients receiving SPRYCEL 70 mg BID. QT interval was corrected for heart rate by Fridericia's method. At all post-dose time points on day 8, the mean changes from baseline in QTcF interval were 4-6 msec, with associated upper 95% confidence intervals <7 msec. Of the 2182 patients who received SPRYCEL in clinical trials, 21 patients (<1%) experienced a QTcF >500 msec. (See WARNINGS AND PRECAUTIONS.)

Pharmacokinetics

The pharmacokinetics of SPRYCEL (dasatinib) were evaluated in 229 healthy subjects and in 84 patients with leukemia.

Absorption: Dasatinib is rapidly absorbed in patients following oral administration. Peak concentrations were observed between 0.25-6 hours. The overall mean terminal half-life of dasatinib is approximately 3 to 5 hours

Distribution: In patients, SPRYCEL has a large apparent volume of distribution (2505 L) suggesting that the drug is extensively distributed in the extravascular space.

Metabolism: Dasatinib is extensively metabolized in humans. In a study of 8 healthy subjects administered 100 mg of [¹⁴C]-labeled dasatinib, unchanged dasatinib represented 29% of circulating radioactivity in plasma. Plasma concentration and measured *in vitro* activity indicate that metabolites of dasatinib are unlikely to play a major role in the observed pharmacology of the drug. CYP3A4 is a major enzyme responsible for the metabolism of dasatinib.

Excretion: Elimination is predominantly in the feces, mostly as metabolites. Following a single oral dose of [¹⁴C]-labeled dasatinib, approximately 89% of the dose was eliminated within 10 days, with 4% and 85% of the administered radioactivity recovered in the urine and feces, respectively. Unchanged dasatinib accounted for 0.1% and 19% of the administered dose in urine and feces, respectively, with the remainder of the dose being metabolites.

Special Populations and Conditions:

Pediatrics: No clinical studies were conducted with SPRYCEL in pediatric populations.

Hepatic Insufficiency: The effect of hepatic impairment on the single-dose pharmacokinetics of dasatinib was assessed in 8 moderately hepatic impaired subjects who received a 50-mg dose and 5 severely hepatic-impaired subjects who received a 20-mg dose compared to matched healthy subjects who received a 70-mg dose of SPRYCEL. The mean C_{max} and AUC of dasatinib adjusted for the 70-mg dose was decreased by 47% and 8%, respectively, in moderate hepatic impairment compared to subjects with normal hepatic function. In severe hepatic impaired subjects, the mean C_{max} and AUC adjusted for the 70-mg dose was decreased by 43% and 28%, respectively, compared to subjects with normal hepatic function. Hepatic impairment did not result in clinically meaningful change in dasatinib exposure at the doses studied. However no pharmacokinetic information is available from patients with hepatic impairment treated with a 70-100 mg dose of SPRYCEL. Due to limitations of this clinical study, caution is recommended in patients with hepatic impairment (See WARNINGS AND PRECAUTIONS and DOSAGE AND ADMINISTRATION).

Renal Insufficiency: No clinical studies were conducted with SPRYCEL in patients with decreased renal function. Less than 4% of SPRYCEL and its metabolites are excreted via the kidney. (See WARNINGS AND PRECAUTIONS.)

Drug-Drug Interactions

See DRUG INTERACTIONS section.

Drug-Food Interactions

Data from a study of 54 healthy subjects administered a single, 100-mg dose of dasatinib 30 minutes following consumption of a high-fat meal indicated a 14% increase in the mean AUC of dasatinib. Consumption of a low-fat meal 30 minutes prior to dasatinib resulted in a 21% increase in the mean AUC of dasatinib. The observed food effects do not represent clinically relevant changes in exposure.

STORAGE AND STABILITY

SPRYCEL (dasatinib) tablets should be stored at room temperature between 15°–30° C.

SPECIAL HANDLING INSTRUCTIONS

Procedures for proper handling and disposal of anticancer drugs should be considered. Several guidelines on this subject have been published. There is no general agreement that all of the procedures recommended in the guidelines are necessary or appropriate.

SPRYCEL (dasatinib) tablets consist of a core tablet (containing the active drug substance), surrounded by a film coating to prevent exposure of pharmacy and clinical personnel to the active drug substance. However, if tablets are crushed or broken, pharmacy and clinical personnel should wear disposable chemotherapy gloves. Personnel who are pregnant should avoid exposure to crushed and/or broken tablets.

DOSAGE FORMS, COMPOSITION AND PACKAGING.

SPRYCEL (dasatinib) film coated tablets are available for oral administration in strengths 20 mg, 50 mg, 70 mg, 80 mg, 100 mg and 140 mg dasatinib (as monohydrate) containing the following non-medicinal ingredients for the tablet core: croscarmellose sodium, hydroxypropyl cellulose, lactose monohydrate, magnesium stearate and microcrystalline cellulose. The film-coating contain the following inactive ingredients: hypromellose, polyethylene glycol and titanium dioxide.

SPRYCEL 20 mg tablet is white to off-white, biconvex, round, film coated tablet with “BMS” debossed on one side and “527” on the other.

SPRYCEL 50 mg tablet is white to off-white, biconvex, oval, film coated tablet with “BMS” debossed on one side and “528” on the other side.

SPRYCEL 70 mg tablet is white to off-white, biconvex, round, film coated tablet with “BMS” debossed on one side and “524” on the other side

SPRYCEL 80 mg tablet is white to off-white, biconvex, triangle, film coated tablet with “BMS” and “80” (BMS over 80) debossed on one side and “855” on the other side

SPRYCEL 100 mg tablet is white to off-white, biconvex, oval, film coated tablet with “BMS 100” debossed on one side and “852” on the other side

SPRYCEL 140 mg tablet is white to off-white, biconvex, round, film-coated tablet with “BMS” and “140” (BMS over 140) debossed on one side and “857” on the other side.

SPRYCEL film coated tablets, 20 mg, 50 mg and 70 mg, are supplied in HDPE bottles containing 60 tablets and in blister packs of 60 tablets.

SPRYCEL film coated tablets, 80 mg, 100 mg and 140 mg are supplied in HDPE bottles containing 30 tablets and in blister packs of 30 tablets.

PART II: SCIENTIFIC INFORMATION

PHARMACEUTICAL INFORMATION

Drug Substance

Proper name: dasatinib
Chemical name: *N*-(2-chloro-6-methylphenyl)-2-[[6-[4-(2-hydroxyethyl)-1-piperazinyl]-2-methyl-4-pyrimidinyl]amino]-5-thiazolecarboxamide, monohydrate
Molecular formula: $C_{22}H_{26}ClN_7O_2S \cdot H_2O$
Structural formula:

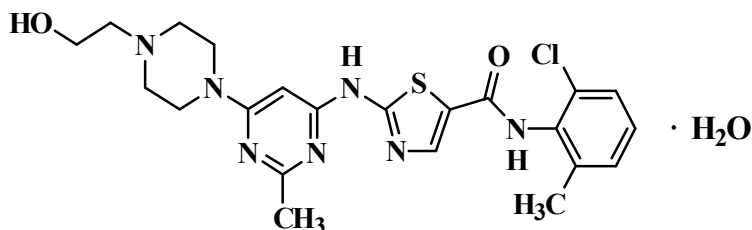

Molecular weight: 488.01 (anhydrous free base)

Physicochemical properties: Dasatinib is a white to off-white powder, which may contain lumps, and has a melting point of 280°–286° C. The drug substance is insoluble in water (0.008 mg/mL) at 24 ± 4° C. The pH of a saturated solution of dasatinib in water is about 6.0. Two basic ionization constants (pK_a) were determined to be 6.8 and 3.1, and one weakly-acidic pK_a was determined to be 10.9. The solubilities of dasatinib in various solvents at 24 ± 4°C are as follows: slightly soluble in ethanol (USP), methanol, polyethylene glycol 400, and propylene glycol; very slightly soluble in acetone and acetonitrile; and practically insoluble in corn oil.

CLINICAL TRIALS

Newly Diagnosed Chronic Phase CML

An open-label, multicenter, international (Europe, South America and Asia-Pacific regions), randomized, Phase III study was conducted in adult patients with newly diagnosed chronic phase CML. Patients were randomized to receive either SPRYCEL 100 mg once daily or imatinib 400 mg once daily. The primary endpoint was the rate of confirmed complete cytogenetic response (cCCyR) within 12 months. Secondary endpoints included time-in cCCyR (measure of durability of response), time-to cCCyR, major molecular response (MMR) rate, time-to MMR, progression

free survival (PFS), and overall survival (OS). The secondary endpoints were evaluated on a yearly basis. A pre-specified statistical comparison of these endpoints was conducted with data from up to 60 months of follow-up.

A total of 519 patients were randomized to a treatment group: 259 to SPRYCEL and 260 to imatinib. Baseline characteristics were well balanced between the two treatment groups with respect to age (median age was 46 years for the SPRYCEL group and 49 years for the imatinib group with 10% and 11% of patients 65 years of age or older, respectively), gender (women 44% and 37%, respectively), and race (Caucasian 51% and 55%; Asian 42% and 37%, respectively). At baseline, the distribution of Hasford Scores was similar in the SPRYCEL and imatinib treatment groups (low risk: 33% and 34%; intermediate risk: 48% and 47%; high risk: 19% and 19%, respectively). The ECOG Performance Score was also similar in the SPRYCEL and imatinib treatment groups (ECOG 0 = 82% and 79%; ECOG 1 = 18% and 20%; and ECOG 2 = 0 and 1%, respectively).

With a minimum of 12 months follow-up, 84% of patients randomized to the SPRYCEL group and 81% of patients randomized to the imatinib group were still receiving first-line treatment. Discontinuation due to disease progression occurred in 3% of SPRYCEL-treated patients and 5% of imatinib-treated patients. With a minimum of 36 months follow-up, 71% of patients randomized to the SPRYCEL group and 69% of patients randomized to the imatinib group were still receiving first-line treatment. With a minimum of 60 months follow-up, 61% of patients randomized to the SPRYCEL group and 63% of patients randomized to the imatinib group were still receiving first-line treatment. Discontinuation due to disease progression occurred in 7% of SPRYCEL-treated patients and 8.5% of imatinib-treated patients.

Efficacy results are presented in Table 7. A statistically significantly greater proportion of patients in the SPRYCEL group achieved a cCCyR compared with patients in the imatinib group within the first 12 months of treatment. This result was generally consistent across different subgroups, including age, gender, and baseline Hasford score. No statistically significant difference in the secondary endpoint, time-in cCCyR, was demonstrated between SPRYCEL and imatinib at the 60 month analysis. In accord with the pre-specified sequential testing strategy, formal statistical testing stopped after the treatment comparison for Time-in cCCyR was found to be not statistically significant. Therefore statistical comparisons with remaining secondary endpoints were not conducted.

Table 7: Efficacy Results in Newly Diagnosed Patients with Chronic Phase CML

	SPRYCEL (n=259)	Imatinib (n=260)	p-value
Response rate (95% CI)			
Cytogenetic Response			
within 12 months			
cCCyR ^a	76.8% (71.2–81.8)	66.2% (60.1–71.9)	p = 0.007*
within 24 months			
cCCyR ^a	80.3% (74.9-85.0)	74.2% (68.5-79.4)	----**
within 36 months			
cCCyR ^a	82.6% (77.5-87.0)	77.3% (71.7-82.3)	----**
within 60 months			
cCCyR ^a	83.0% (77.9-87.4)	78.5% (73.0-83.3)	----**
Major Molecular Response^b			
12 months	52.1% (45.9–58.3)	33.8% (28.1–39.9)	p<0.00003*
24 months	64.5% (58.3-70.3)	50% (43.8-56.2)	----**
36 months	69.1% (63.1-74.7)	56.2% (49.9-62.3)	----**
60 months	76.4% (70.8-81.5)	64.2% (58.1-70.1)	----***
Hazard Ratio (99.99% CI)			
within 60 months (95% CI)			
Time-in cCCyR	0.79 [0.55, 1.13]		NS
within 12 months (99.9% CI)			
Time-to cCCyR	1.55 (1.0–2.3)		p<0.0001*
Time-to MMR	2.01 (1.2–3.4)		p<0.0001*
within 24 months (95% CI)			
Time-to cCCyR	1.49 (1.22–1.82)		—
Time-to MMR	1.69 (1.34–2.12)		—
within 36 months (95% CI)			
Time-to cCCyR	1.48 (1.22–1.80)		—
Time-to MMR	1.59 (1.28–1.99)		—

Table 7: Efficacy Results in Newly Diagnosed Patients with Chronic Phase CML

	SPRYCEL (n=259)	Imatinib (n=260)	p-value
	Response rate (95% CI)		
	within 60 months (95% CI)		
Time-to cCCyR	1.46 (1.20–1.77)		----***
Time-to MMR	1.54 (1.25–1.89)		----***

^a Confirmed complete cytogenetic response (cCCyR) is defined as a response noted on two consecutive occasions (at least 28 days apart).

^b Major molecular response (at any time) was defined as BCR-ABL ratios $\leq 0.1\%$ by RQ-PCR in peripheral blood samples standardized on the International Scale. Some subjects at the time of minimum follow up corresponding to a specific yearly database cutoff had been on treatment longer, and may have achieved an MMR beyond the corresponding 12, 24 or 36 months of treatment.

*Adjusted for Hasford Score and indicated statistical significance at a pre-defined nominal level of significance.

**Per protocol, formal statistical comparison of cCCyR and MMR rates was only performed at the time of the primary endpoint (cCCyR within 12 months).

***Based on hierarchical statistical testing procedure, formal testing was not done on this secondary endpoint since Time-in cCCyR was not significant.

CI = confidence interval.

NS= not statistically significant

Median time to cCCyR was 3.1 (3.0-3.1) months in 215 SPRYCEL responders and 5.8 (5.6-6.0) months in 204 imatinib responders based on 60-month data update. Median time to MMR (based on 60-month data update) was 9.3 months in 198 SPRYCEL responders and 15.0 months in 167 imatinib responders. The rates of cCCyR in the SPRYCEL and imatinib treatment groups, respectively, within 3 months (54% and 30%), 6 months (70% and 56%), 9 months (75% and 63%), 24 months (80% and 74%) and 36 months (83% and 77%), and 60 months (83 % and 79%) were consistent with the primary endpoint.

At 60 months follow-up in the SPRYCEL arm, the rate of MMR at any time in each risk group determined by Hasford score was 90% (low risk), 71% (intermediate risk) and 67% (high risk).

The rate of cCCyR at any time in each risk group determined by Hasford score was 94% (low risk), 77% (intermediate risk) and 78% (high risk).

The estimated progression-free survival rate at 60 months for dasatinib-treated subjects was 88.9% (95% CI = [84.0%, 92.4%]). The estimated overall survival rate at 60 months for dasatinib-treated subjects was 90.9% (95% CI = [86.6%, 93.8%]).

Disease progression (defined as ‘loss of complete hematologic response’, ‘loss of major cytogenetic response’, ‘rising WBC on two occasions at least one month apart’, ‘transformation to accelerated, blast phase of CML’ or ‘death’) was reported in 34 (13.0%) patients treated with SPRYCEL and 39 (15%) patients with imatinib. Treatment failure (defined according to the 2006 European LeukemiaNet Guidelines, included disease progression, a lack of a hematologic response

at 3 months, a lack of a complete hematologic response or CyR at 6 months, a lack of partial CyR at 12 months, or a lack of CCyR at 18 months) occurred in 10 (3.9%) of SPRYCEL-treated patients and 14 (5.4%) of imatinib-treated patients at 60 months. Transformation to accelerated or blast phase was reported in 8 (3.1%) SPRYCEL-treated patients and 15 (5.8%) imatinib-treated patients. Deaths were reported in 26 (10.1%) patients treated with SPRYCEL and 26 (10.1%) patients treated with imatinib.

BCR-ABL kinase domain sequencing was performed on blood samples from patients at the time of discontinuation or study closure. At 60 months follow-up, T315I, F317I/L, F317I/V299L and V299L mutations were detected in 15 patients who discontinued SPRYCEL treatment including 8 with T315I. Mutations including M244V, L387M, D276G/F359C, H396P/R, G250E, F359C/I/V, E255K, E355G, E255K/V, E355G/L248V, E255V/Y253H, F317L, and E450G were detected in 19 patients who discontinued imatinib. The T315I mutation confers resistance to treatment with dasatinib and other ABL tyrosine kinase inhibitors based on *in vitro* and clinical data.

Imatinib Resistant or Intolerant CML or Ph+ ALL

Randomized Studies

Phase III dose-optimization study in chronic phase CML: A randomized, open-label study was conducted in patients with chronic phase CML to evaluate the efficacy of SPRYCEL administered once daily compared with SPRYCEL administered twice daily. The primary endpoint was MCyR in imatinib-resistant patients. The main secondary endpoint was MCyR by total daily dose level in the imatinib-resistant patients at 24-months follow-up. Other secondary endpoints included duration of MCyR and overall survival. A total of 670 patients, of whom 497 were imatinib resistant, were randomized to the SPRYCEL 100 mg once daily, 140 mg once daily, 50 mg twice daily, or 70 mg twice daily group. Median duration of treatment was 22 months.

Resistance to imatinib was defined as failure to achieve a CHR (after 3 months), MCyR (after 6 months), or CCyR (after 12 months); or loss of a previous molecular response (with concurrent $\geq 10\%$ increase in Ph+ metaphases), cytogenetic response, or hematologic response.

Progression in the chronic phase CML was defined as any of the following events: loss of a CHR or MCyR; no CHR with an increase in white blood cell count; development of accelerated or blast phase CML; a $\geq 30\%$ increase in the number of Ph+ metaphases; or death.

Efficacy was achieved across all SPRYCEL treatment groups with the once daily schedule demonstrating comparable efficacy (non-inferiority) to the twice daily schedule on the primary efficacy endpoint in imatinib resistant patients (difference in MCyR 1.9%; 95% confidence interval [-6.8%–10.6%]); however, the 100 mg once daily regimen demonstrated improved efficacy and tolerability. The main secondary endpoint of the study also showed comparable efficacy (non-inferiority) among imatinib-resistant patients between the 100 mg total daily dose and the 140 mg total daily dose (difference in MCyR -0.2%; 95% CI [-8.9%–8.5%]). Two year efficacy results are presented in Table 8.

Table 8: Efficacy of SPRYCEL in Phase III Dose-Optimization Study: Imatinib-Resistant or Intolerant Chronic Phase CML Patients (2-year results)^a

All Patients	n = 167
Imatinib-Resistant Patients	n = 124
Haematologic Response Rate^b (%) (95% CI)	
CHR	92% (86-95)
Cytogenetic Response^c (%) (95% CI)	
MCyR	
All Patients	63% (56-71)
Imatinib-Resistant Patients	59% (50-68)
CCyR	
All Patients	50% (42-58)
Imatinib-Resistant Patients	44% (35-53)

^a Results reported in recommended starting dose of 100 mg once daily

^b Haematologic response criteria (all responses confirmed after 4 weeks):

CHR (chronic CML): WBC \leq institutional ULN, platelets $< 450,000/\text{mm}^3$, no blasts or promyelocytes in peripheral blood, $< 5\%$ myelocytes plus metamyelocytes in peripheral blood, basophils in peripheral blood $< 20\%$, and no extramedullary involvement.

^c Cytogenetic response criteria: complete (0% Ph⁺ metaphases) or partial ($> 0\%$ -35%). MCyR (0%-35%) combines both complete and partial responses.

A total of 378 out of 670 patients (56%) with chronic phase CML had abnormal blood count at entry; 317 out of the 378 (84%) patients achieved a CHR from an abnormal baseline (high WBC counts becoming normal and maintained for at least 4 weeks without any other concomitant therapy). A total of 554 out of 670 patients (83%) had abnormal cytogenetics at study entry.

Major molecular response (defined as BCR-ABL/control transcripts $\leq 0.1\%$ by RQ-PCR in peripheral blood samples) was evaluated in a subset of assessed patients who had a CCyR.

Major molecular response was achieved in 72% (95% CI [58-83%]) of imatinib-resistant patients in the SPRYCEL 100 mg once daily group.

Subjects on a BID dosing schedule were permitted to switch to a QD dosing schedule after 24 months of treatment. After 24 months of treatment cytogenetic response was not assessed; blood count with differential and molecular response were assessed once a year.

Based on the Kaplan-Meier estimates, the proportion of patients among those who achieved MCyR on 100 mg of SPRYCEL once daily and maintained MCyR for 18 months was 93% (95% CI: [88%-98%]).

Based on the Kaplan-Meier estimates, the proportions of patients with PFS at 1 year were 88% (95% CI [82-94%]) of imatinib-resistant patients in the 100 mg once daily group. At 2 years, the estimated rates of PFS were 77% (95% CI [68-85%]) of imatinib-resistant patients in the 100 mg once daily group. At 5 years, the estimated rates of PFS were 49% (95% CI [39-59%]) of imatinib-resistant patients in the 100 mg once daily group. At 7 years, the estimated rates of PFS were 39% (95% CI [29-49%]) of imatinib-resistant patients in the 100 mg once daily group.

The estimated rates of overall survival at 1 year were 94% (95% CI [90-98%]) of imatinib-resistant patients in the 100 mg once daily group. At 2 years, the estimated rates of overall survival were 89% (95% CI [84-95%]) of imatinib-resistant patients in the 100 mg once daily group. At 5 years,

the estimated rates of overall survival were 77% (95% CI [69-85%]) of imatinib-resistant patients in the 100 mg once daily group. At 7 years, the estimated rates of overall survival were 63% (95% CI [53-71%]) of imatinib-resistant patients in the 100 mg once daily group.

Efficacy was also assessed in patients who were intolerant to imatinib. In this population of patients who received 100 mg once daily, MCyR was achieved in 77%, CCyR in 67%, and major molecular response in 64%. Based on the Kaplan-Meier estimates, all imatinib-intolerant patients who achieved MCyR (100%) maintained MCyR for 1 year and 92% (95% CI: [80%-100%]) among those who achieved MCyR maintained MCyR for 18 months. The estimated rate of PFS in this population was 97% (95% CI: [92%-100%]) at 1 year, 87% (95% CI: [76%-99%]) at 2 years, 56% (95% CI [37%-76%]) at 5 years, and 50.9% (95% CI: [32.1%-67.0%]) at 7 years. The estimated rate of overall survival was 100% at 1 year, 95% (95% CI: [88%-100%]) at 2 years, 82% (95% CI: [70%-94%]) at 5 years, and 70.0% (95% CI: [52.2%-82.2%]) at 7 years.

Phase III dose-optimization study in advanced phase CML and Ph+ ALL: A randomized, open-label study was conducted in patients with accelerated phase CML, myeloid blast phase CML, lymphoid blast phase CML, or Ph+ ALL to evaluate the efficacy of SPRYCEL administered once daily compared with SPRYCEL administered twice daily. The primary endpoint was the rate of MaHR. Secondary endpoints included the rate of MCyR, duration of MaHR, PFS, and overall survival. A total of 611 patients were randomized to the SPRYCEL 140 mg once daily or 70 mg twice daily group. Median duration of treatment was 14 months for accelerated phase CML, 3 months for myeloid blast CML, 4 months for lymphoid blast CML, and 3 months for Ph+ ALL.

Resistance to imatinib was defined as no hematologic response or a $\geq 50\%$ increase in blasts in peripheral blood; loss of a hematologic response; progression to blast or accelerated phase CML with blasts in peripheral blood while on treatment with imatinib.

Progression was defined as follows:

- Accelerated phase CML: Loss of a CHR, NEL, or MiHR; development of blast phase CML; no decrease from baseline percent blasts in peripheral blood or bone marrow; development of extramedullary sites (other than spleen or liver); a $\geq 50\%$ increase in blasts in peripheral blood; or death.
- Blast phase CML or Ph+ ALL: Loss of a CHR, NEL, or MiHR; no decrease from baseline percent blasts in peripheral blood or bone marrow; a $\geq 50\%$ increase in blasts in peripheral blood; or death.

Results described below are based on a minimum of 24 months follow-up.

The once daily schedule demonstrated comparable efficacy (non-inferiority) to the twice daily schedule on the primary efficacy endpoint (difference in MaHR 0.8%; 95% confidence interval [-7.1% - 8.7%]); however, the 140 mg once daily regimen demonstrated improved safety and tolerability. Response rates for patients in the 140 mg once daily group are presented in Table 9.

Table 9: Efficacy of SPRYCEL in Phase III Dose-Optimization Study: Advanced Phase CML and Ph+ ALL (2 Year Results)^a

	140 mg Once Daily			
	Accelerated (n=158)	Myeloid Blast (n=75)	Lymphoid Blast (n=33)	Ph+ ALL (n=40)
MaHR^b	66%	28%	42%	38%
(95% CI)	(59-74)	(18-40)	(26-61)	(23-54)
CHR^b	47%	17%	21%	33%
(95% CI)	(40-56)	(10-28)	(9-39)	(19-49)
NEL^b	19%	11%	21%	5%
(95% CI)	(13-26)	(5-20)	(9-39)	(1-17)
MCyR^c	39%	28%	52%	70%
(95% CI)	(31-47)	(18-40)	(34-69)	(54-83)
CCyR	32%	17%	39%	50%
(95% CI)	(25-40)	(10-28)	(23-58)	(34-66)

^a Results reported in recommended starting dose of 140 mg once daily.

^b Hematologic response criteria (all responses confirmed after 4 weeks): Major hematologic response (MaHR) = complete hematologic response (CHR) + no evidence of leukemia (NEL).

CHR: WBC ≤ institutional ULN, ANC ≥1000/mm³, platelets ≥100,000/mm³, no blasts or promyelocytes in peripheral blood, bone marrow blasts ≤5%, <5% myelocytes plus metamyelocytes in peripheral blood, basophils in peripheral blood <20%, and no extramedullary involvement.

NEL: same criteria as for CHR but ANC ≥500/mm³ and <1000/mm³, or platelets ≥20,000/mm³ and ≤100,000/mm³.

^c MCyR combines both complete (0% Ph+ metaphases) and partial (>0%-35%) responses.

CI = confidence interval

ULN = upper limit of normal range.

A total of 529 out of 611 patients (87%) with advanced phase CML or Ph+ ALL had abnormal blood count at entry; 238 out of the 529 (45%) patients achieved a MaHR from an abnormal baseline (high WBC counts becoming normal and maintained for at least 4 weeks without any other concomitant therapy)

A total of 526 out of 611 patients (86%) had abnormal cytogenetics at study entry.

In patients with accelerated phase CML treated with the 140 mg once daily regimen, the median duration of MaHR and the median overall survival was not reached; the median PFS was 25 months. In patients with myeloid blast phase CML, treated with the 140 mg once daily regimen, the median duration of MaHR was 8 months, the median PFS was 4 months and the median overall survival was 8 months. In patients with lymphoid blast phase CML, the median duration of MaHR was 5 months, the median PFS was 5 months, and the median overall survival was 11 months.

DETAILED PHARMACOLOGY

Nonclinical pharmacodynamics

Extensive *in vitro* and *in vivo* studies demonstrated that dasatinib is a potent inhibitor of BCR-ABL and SRC family kinases along with a number of other kinases including c-KIT, ephrin (EPH) receptor kinases, and PDGFβ receptor. Dasatinib is active *in vitro* and *in vivo* in numerous

nonclinical models of CML representing variants of both imatinib-sensitive and -resistant diseases. Nonclinical studies show that dasatinib can overcome the imatinib resistance that results from divergent mechanisms including BCR-ABL kinase domain mutations, BCR-ABL overexpression, activation of alternate signaling pathways involving the SRC family kinases, and multidrug resistance gene overexpression.

Nonclinical studies demonstrate that dasatinib is capable of binding to the active conformation of BCR-ABL kinase domains, and is predicted to bind to the inactive form. Dasatinib is 300- to 1000-fold more potent than imatinib in killing human CML cells that harbor wild-type or mutant BCR-ABL *in vitro*. In a murine model of CML, dasatinib prevents the progression of chronic CML to blast phase. *In vivo*, dasatinib inhibits the growth and prolonged the survival of mice bearing xenografts of imatinib-sensitive (including an intracranial model) and one imatinib-resistant CML cell line.

Nonclinical pharmacokinetics

The absorption, distribution, metabolism and excretion properties of dasatinib were evaluated in a series of *in vitro* and *in vivo* studies in mice, rats, rabbits, dogs and monkeys. Dasatinib had a good intrinsic membrane permeability *in vitro* and was rapidly absorbed following oral administration in all species and humans.

In rats and monkeys, systemic exposure was dose related with no apparent gender differences. No notable accumulation was observed after once-daily repeated dosing. After oral administration of [¹⁴C] dasatinib to rats, monkeys, and humans, drug-derived radioactivity was recovered primarily in the feces (>76%), with only a small portion of the dose (<7%) excreted in the urine. In all species tested, dasatinib was shown to undergo extensive metabolism, including hydroxylation, N-oxidation, N-dealkylation, oxidation to form a carboxylic acid, glucuronidation and sulfation. Dasatinib was the most abundant drug-related component in the plasma from these species, with multiple oxidative and conjugated metabolites also present. All metabolites identified in human plasma were also found in monkey plasma. The ADME profiles of dasatinib in mice, rats, rabbits, dogs and monkeys as compared to humans suggest that these species were appropriate for safety assessment of dasatinib and its metabolites.

Multiple enzymes were involved in the metabolism of dasatinib with CYP3A4 playing a major role. The involvement of CYP3A4 was confirmed in clinical studies where the exposure of dasatinib was substantially decreased (> 80%) when it was administered 12 hours following 7-day treatment with rifampin, a potent inducer of CYP3A4. *In vitro* studies indicated that dasatinib was not an inducer of CYP enzymes. It inhibited CYP2C8 in a competitive manner and CYP3A4 in a time dependent manner. Based on the C_{max} of dasatinib at the therapeutic dose, the probability of drug-drug interactions is low with co-administered drugs that are CYP2C8 substrates. However, there is a possibility of interaction with drugs that are CYP3A4 substrates given that clinical study with co-administration of dasatinib with simvastatin resulted in a moderate increase in the exposure of simvastatin and its acid.

TOXICOLOGY

Acute Toxicity

The single-dose oral toxicity of dasatinib was evaluated in rats at doses of 30, 100, and 300 mg/kg, and in monkeys at doses of 15, 25, and 45 mg/kg. In rats, dasatinib at 30 mg/kg was tolerated, and doses \geq 100 mg/kg caused severe toxicity and death. Morbidity and mortality were attributed to gastrointestinal lesions resulting in fluid and electrolyte loss and impairment of mucosal integrity, bone-marrow and lymphoid depletion, and multifocal myocardial necrosis and hemorrhage. In monkeys, dasatinib was tolerated at doses up to 25 mg/kg, whereas a dose of 45 mg/kg resulted in severe toxicity and mortality at Days 1 and 2. Principal drug-related toxicities occurred in the skin (hemorrhage) at doses \geq 15 mg/kg, GI and lymphoid-organ systems at doses \geq 25 mg/kg, and kidney at 45 mg/kg.

Acute Toxicity

Species/ Strain	Route of Administration	Duration of Dosing	Dose (mg/kg)	N/Dose/ Sex	Findings
Rat / SD	Oral gavage	Single dose	30, 100, 300	10 M 10 F	<p><u>≥ 30 mg/kg</u>: Dose-related decreased food intake, mucous feces, soiled/rough haircoat, dehydration, chromodacryorrhea, and chromorhinorrhea. Decreased size and weight of the thymus, decreased spleen weights (M), increased liver weights (F), red discoloration, ulceration, hemorrhage, and/or edema in the stomach, bone marrow depletion, and lymphoid depletion in the thymus, spleen, and/or lymph nodes. Decreases in total leukocyte, lymphocyte, monocyte, and platelet counts; increases in fibrinogen, ALT and AST, and decreases in albumin, total protein, albumin/globulin ratio, ALP, potassium, calcium and phosphorus.</p> <p><u>≥ 100 mg/kg</u>: Mortality (55% at 100 mg/kg by Day 4, 100% at 300 mg/kg by Day 3). Prior to death, decreased activity, hunched posture, pallor, surface hypothermia, ptosis, tremors (F), and absence of feces (F). Hemorrhage and/or coagulative necrosis, macrophage infiltration, hemosiderosis, and fibrosis in the heart, Red/black discoloration of the intestines and lymph nodes, red discoloration of the ovaries, tan discoloration of the liver, and decreased size of the spleen. Enteropathy in the small intestine, hemorrhage or ulceration in the small intestine (F at 300 mg/kg), renal tubular dilatation and epithelial vacuolation, increases in urinary blood and bilirubin (M), lymphoid depletion in intestinal lymphoid nodules, single-cell necrosis in the liver (F), hemorrhage in the epididymides, and testicular degeneration.</p>
Monkey / Cynomolgus	Oral gavage	Single dose	15, 25, 45	2 M 2 F	<p><u>≥ 15 mg/kg</u>: Decreased activity, surface hypothermia with decreased body temperature, dehydration, and hemorrhages at multiple sites (thorax, limbs, gingiva, head, neck and, in 1 monkey, retina). Increases in AST, decreases in total protein, globulins, and albumin, and increases or decreases in phosphorus.</p> <p><u>≥ 25 mg/kg</u>: Fecal changes (soft, liquid, bloody), pallor of mucous membranes, and decreased body weights and food intake. Lymphoid depletion in the spleen, lymph nodes, and lymphoid nodules of the stomach and intestines, and, in 1 monkey, edema in the stomach. Increases in ALT and urea nitrogen, and decreases in calcium, cholesterol, triglycerides, and γ-GT.</p> <p><u>45 mg/kg</u>: Mortality (100% by Days 1 or 2). Prior to death, emesis and increased muscle tone and tremors. Red or abnormal contents of the intestines (F), hemorrhage in the tongue, red discoloration and hemorrhage in the stomach and intestines, dilatation of cortical tubules of the kidney (F), increases in creatinine and potassium (F).</p>

Short- and Long-Term Toxicity

Repeat-dose oral toxicity studies were conducted in rats for 2 weeks to 6 months, and in monkeys for 10 days to 9 months. Repeat-dose oral toxicity studies were conducted using a daily dosing regimen (2-week and 6-month studies in rats) or a 5-days on, 2-days off dosing schedule (1-month study in rats, and 10-day, 1-month, and 9-month studies in monkeys) to support a flexible clinical development plan. In both rats and monkeys, the principal drug-related toxicities were manifested in the GI and lymphoid-organ systems. Hematopoietic (bone marrow) toxicity was also a consistent finding in rats following single or repeated oral doses of dasatinib, and was accompanied by decreases in erythrocyte, lymphocyte, and platelet counts. In monkeys, minimal bone marrow toxicity occurred only in a small number of animals following repeat dosing, and was generally accompanied by decreases in erythrocyte and lymphocyte counts. In a 9-month monkey study, toxicity related to gastroenteropathy, lymphocytic depletion and others necessitated euthanasia of 50% of the animals at exposures that were only half of the systemic exposure in humans at a dose of 70 mg BID.

Short- and Long-Term Toxicity

Species/ Strain	Route of Administration	Duration of Dosing	Dose (mg/kg)	N/Dose/ Sex	Findings
Rat / SD	Oral gavage	2 weeks (daily dosing)	1, 15, 30	6 M 6 F	<p><u>1 mg/kg</u>: No drug-related changes.</p> <p><u>≥ 15 mg/kg</u>: Chromorhinorrhea, soiled/rough haircoat, dehydration, soft feces, and bloated/swollen abdomen (F at 15 mg/kg). Distention of the GI tract with gas, fluid, and/or ingesta or digesta. Enteropathy of the small and large intestines, edema of the large intestine, red discoloration of the mesenteric lymph nodes, decreased size of the thymus, and lymphoid depletion of the spleen, thymus, and lymph nodes. At 15 mg/kg, changes in erythrocyte parameters (decreases in erythrocyte counts, hemoglobin, and hematocrit, and increases in reticulocyte counts, MCV, and MCH), increased liver (F) and adrenal weights, and decreased kidney (M), thymus, and spleen weights.</p> <p><u>30 mg/kg</u>: Mortality (100%). Prior to death, decreased activity, surface hypothermia, pallor, diarrhea, hunched posture, ptosis, thin appearance, decreased body weight gain (F), body weight loss (M), and decreased food intake. Red discoloration of the small intestine (M), lymphoid depletion in the spleen and thymus, and bone-marrow haematopoietic depletion.</p>
Rat / SD	Oral gavage	1 month (5-days on, 2-days off)	0.9, 15, 25	15 M 15 F	<p><u>≥ 0.9 mg/kg</u>: Decreased food consumption (M).</p> <p><u>≥ 15 mg/kg</u>: Changes in erythrocyte parameters (decreases in erythrocyte counts, hemoglobin, and hematocrit, and increases in MCV and MCH). Decreased body-weight gain (M) and spleen weights, and increases in liver weights (F). Enteropathy in the gastrointestinal tract. Lymphoid depletion, edema, and/or hemorrhage in the thymus.</p> <p><u>25 mg/kg</u>: Mortality (43%) due to enteropathy/lymphoid depletion. Distention and red discoloration of the gastrointestinal tract, hemorrhage in the stomach, edema in the cecum, red discoloration of the mesenteric lymph node, lymphoid depletion in the spleen, and hypocellularity in the bone marrow accompanied with hematological changes.</p>
Rat / SD	Oral gavage	6 months (daily dosing)	1.5, 4, 15/10/8	25 M 25 F	<p>The high dose of 15 mg/kg was reduced to 10 mg/kg in Week 8 and then to 8 mg/kg in Week 17 due to gastrointestinal toxicity.</p> <p><u>≥ 1.5 mg/kg/day</u>: Increased heart weights. Gastrointestinal changes of villous blunting/fusion/branching and/or epithelial hyperplasia, increased vacuolation in the adrenal cortex, increased corpora lutea in the ovary and decreased incidence of acyclic ovaries, fluid-filled uteri and decreased squamous metaplasia of endometrial glands in the uterus.</p>

Species/ Strain	Route of Administration	Duration of Dosing	Dose (mg/kg)	N/Dose/ Sex	Findings
					<p><u>≥ 4 mg/kg/day</u>: The systemic exposure of dasatinib at 4 mg/kg was similar to that of humans at the therapeutic dose. Increased weights of ovaries, liver, adrenal glands, and thyroid/ parathyroid glands, and decreased weights of the pituitary gland. Fibrosis and crypt ectasia/abscesses in the cecum, and increased colloid in the thyroid.</p> <p><u>15/10/8 mg/kg</u>: Mortality (30%) at systemic exposure of dasatinib 2-4x that of humans at the therapeutic dose. In surviving animals, swollen abdomen, few or liquid feces, and fecal stained haircoat. Reversible bone marrow hypocellularity (minimal or moderate, 2 rats) or individual cell necrosis (minimal, 1 rat), changes in erythrocyte parameters (decreased erythrocyte counts, hemoglobin, and hematocrit, and increased MCV, MCH, and reticulocyte counts), and platelet parameters (increased platelet counts and decreases in platelet aggregation), increased neutrophil counts and fibrinogen, and decreased serum proteins (total protein, albumin, and globulins).</p>
Dog / Beagle	Oral gavage	2 days	5	1 M 1 F	Dosing was discontinued after 2 days as a result of severe GI toxicity.
Monkey / Cynomolgus	Oral gavage	10 days	1, 10, 15 (5-days on, 2- days off), 25 (2-3 days), 62.5 (single dose)	1 M 1 F	<p><u>≥ 1 mg/kg/day</u>: Vomitus and fecal changes (soft, liquid, bloody, mucous).</p> <p><u>≥ 15 mg/kg/day</u>: Decreased food consumption, lymphoid depletion in the spleen and/or thymus, decreased spleen weights (15 mg/kg), and minimal enteropathy in the small intestine (10 and 15 mg/kg). Excretion of dasatinib in the urine increased from < 1% to up to 220-fold over the 10 day period in female monkeys.</p> <p><u>≥ 25 mg/kg/day</u>: Mortality (75%, both monkeys at 25 mg/kg and the female at 62.5 mg/kg; a male monkey was given a single dose of 62.5 mg/kg and discontinued). Prior to death, decreased activity, pale mucous membranes, hunched posture, and/or hypothermia. Red discoloration of the stomach (25 mg/kg) and small intestine (25 and 62.5 mg/kg), and red contents in the stomach and intestines (62.5 mg/kg). At 25 mg/kg, lymphoid depletion of intestinal lymphoid nodules and mesenteric lymph nodes and, at 62.5 mg/kg, edema, hemorrhage, and ulceration in the small intestine and tubular dilatation and degeneration in the kidney</p>
Monkey / Cynomolgus	Oral gavage	1 month (5-days on, 2-days off)	1, 5, 15	4 M 4 F	<p><u>1 mg/kg/day</u>: No drug-related effects.</p> <p><u>≥ 5 mg/kg/day</u>: Fecal changes (liquid, nonformed, or no feces).</p> <p><u>15 mg/kg/day</u>: Vomitus, decreased body weight gain (F), and, in 1 M, hunched posture and thin, dehydrated appearance. Abnormal contents (gas and fluid) in the cecum and colon (F). Increases in ALT and decreases in albumin (M). Increases in liver weights and decreases in thymus weights (M). Splenic lymphoid depletion (M) and thymic lymphoid depletion.</p>

Species/ Strain	Route of Administration	Duration of Dosing	Dose (mg/kg)	N/Dose/ Sex	Findings
Monkey / Cynomolgus	Oral gavage	9 months (5-days on, 2-days off)	1, 3/2, 10/6/4.5	6 M 6F	<p>As a result of GI toxicity, the high dose of 10 mg/kg was reduced to 6 mg/kg in Week 3 and then again to 4.5 mg/kg in Week 12; the intermediate dose of 3 mg/kg was reduced to 2 mg/kg in Week 28.</p> <p><u>≥ 1 mg/kg/day</u>: Fecal changes (discolored, liquid, mucoid, nonformed and/or decreased), and low or no food consumption. Erosion/ulceration, acute to subacute inflammation, and epithelial flattening in the large intestine, and increased mineralization in the kidney.</p> <p><u>≥ 3/2 mg/kg/day</u>: Mortality (50%) primarily due to GI toxicity. Mean systemic exposure of dasatinib in the animals at 3/2 mg/kg/day reached only half the AUC of humans at the therapeutic dose (70 mg, BID). Prior to death, vomitus, hunched posture, hypoactivity, and decreased individual body weights. Decreased erythrocyte and lymphocyte counts, hemoglobin, hematocrit, albumin, sodium, potassium, and chloride, and increased total leukocyte and neutrophil counts, fibrinogen, urea nitrogen, and creatinine. Red foci in the large intestine and/or stomach. Lymphoid depletion in the thymus and spleen, and decreases in erythroid cells of the bone marrow.</p> <p><u>10/6/4.5 mg/kg/day</u>: Mortality (100%). None of the monkeys in this dosing group completed the nine month study due to unscheduled euthanasia that resulted from toxicity. Erosion/ulceration in the stomach (1 F), enlarged, gas-distended GI tract (1 M), and red, fluid contents in the stomach and small intestine (1 M).</p>

Genotoxicity

Dasatinib was clastogenic *in vitro* to dividing Chinese hamster ovary cells with and without metabolic activation at concentrations ≥ 5 $\mu\text{g}/\text{mL}$. Dasatinib was not mutagenic when tested in *in vitro* bacterial cell assays (Ames test) and was not genotoxic in an *in vivo* rat micronucleus study.

Test / Test System	Route of Administration	Duration of Dosing	Concentration/ Dose	N/Dose/ Sex	Findings
Bacterial Mutagenicity Screening (Spiral Ames reverse mutation) <i>S. typhimurium</i>	In vitro	48 hr	21 - 5000 $\mu\text{g}/\text{plate}$, with and without rat S9 activation	NA	Not mutagenic.
Bacterial Mutagenicity Screening (Exploratory Ames reverse mutation) <i>S. typhimurium</i>	In vitro	48 hr	5 - 5000 $\mu\text{g}/\text{plate}$, with and without rat S9 activation	NA	Not mutagenic.
Bacterial Mutagenicity (Reverse mutation, definitive study) <i>S. typhimurium</i> and <i>E. coli</i>	In vitro	46-50 hr	12.5 - 400 $\mu\text{g}/\text{plate}$ (<i>S. typhimurium</i>); 50-1600 $\mu\text{g}/\text{plate}$ (<i>E. coli</i>), with and without rat S9 activation	NA	Not mutagenic.
Cytogenetics Study Chinese hamster ovary cells	In vitro	4-20 hr	2.5 - 60 $\mu\text{g}/\text{mL}$, with and without activation	NA	Genotoxic effects: Chromatid and chromosome structural aberrations at ≥ 20 $\mu\text{g}/\text{mL}$ (4 hr -S9), 5 $\mu\text{g}/\text{mL}$ (4 hr +S9), and ≥ 5 $\mu\text{g}/\text{mL}$ (20 hr -S9).
Oral Micronucleus Rat / SD	Oral gavage	3 days	10, 20, 40 mg/kg	5 M 5 F	Genotoxic effects: None.

Reproductive Toxicity

Dasatinib, when administered to pregnant rats during organogenesis at doses of 2.5, 5, 10, or 20 mg/kg , induced fetal toxicity (embryoletality with associated decreases in litter size, and fetal skeletal abnormalities, including malformations) at all doses, and maternal toxicity at doses ≥ 10 mg/kg . Maternal death occurred at 20 mg/kg . In a range-finding study in pregnant rabbits, dasatinib administered during organogenesis caused embryoletality of 13% at 6 mg/kg and 69% at 10 mg/kg . In the definitive embryo-fetal development study in rabbits, dasatinib did not cause maternal toxicity at 0.5, 2, or 6 mg/kg , whereas drug-related fetal skeletal alterations, including malformations, occurred at all doses.

In the oral study of fertility and early embryonic development in rats, dasatinib was not a reproductive toxicant in male rats at doses (≤ 10 mg/kg/day) that approximated human clinical exposures. In female rats, dasatinib did not affect mating or fertility at doses up to 10 mg/kg/day, but induced embryo lethality at doses of ≥ 5 mg/kg/day (post-implantation losses of 14 to 48%, relative to 4% in controls) with associated decreases in litter size. Dasatinib is a selective reproductive toxicant in female rats at clinically relevant systemic exposures.

Dasatinib at doses of 5 and 10 mg/kg/day was given orally to female rats in 3 cohorts for which dosing was initiated on Gestation Day (GD) 16 (the end of organogenesis), GD 21 (the approximate onset of parturition), or Lactation Day (LD) 4 and continued up to LD 20. In all cohorts, in utero or lactational exposure to dasatinib in pups was associated with pleural effusion. For cohorts starting dasatinib on GD 16 or 21 at either dose, all groups were discontinued following 6 to 9 doses when more than 50% of pups had been euthanatized, found dead, or missing/presumed cannibalized. Among dams for which dosing initiated on LD 4, 34% of pups were lost due to mortality or moribundity at 10 mg/kg/day.

Study Type Species/Strain	Route of Administration	Duration of Dosing	Dose (mg/kg)	N/Dose/ Sex	Findings
Embryofetal Development in Rats / SD	Oral gavage	10 days (GD 6 to 15)	2.5, 5, 10, 20	22 F	<p><u>≥2.5 mg/kg</u>: Embryo lethality (17%) and associated decreases in litter size. Fetal skeletal abnormalities.</p> <p><u>≥ 5 mg/kg</u>: Embryo lethality (77%). Fluid-filled thoracic and abdominal cavities, edema, microhepatia in fetus.</p> <p><u>≥ 10 mg/kg</u>: Embryo lethality (100%). Decreased maternal food consumption.</p> <p><u>20 mg/kg</u>: Maternal mortality (22% during Days 12 - 15 of gestation). Decreased maternal body weight gain.</p>
Range Finding Study in Rabbits / NZW	Oral gavage	13 days (GD 7 to 19)	1, 3, 6, 10	7 F	<p><u>1 and 3 mg/kg</u>: No drug-related effects.</p> <p><u>≥ 6 mg/kg</u>: Embryo lethality (13%). Decreased maternal body weight gain and/or weight loss, and decreased food consumption.</p> <p><u>10 mg/kg</u>: Embryo lethality (69%) and reduced number of litters with live fetuses at gestation day 29 (5/7).</p>
Embryo-fetal Development in Rabbits / NZW	Oral gavage	13 days (GD 7 to 19)	0.5, 2, 6	22 F	<p>No maternal toxicity. Delays in ossification of the fetal lumbar vertebrae (bifid arches) and pelvis (incompletely or unossified pubes), reduced ossification of hyoid (incompletely or unossified).</p> <p>6 mg/kg: 21% of fetus resorption among rabbits with post-implantation loss.</p>
Fertility and early embryonic development study in rats (Segment I)	Oral gavage	32 - 45 days 43 days	2.5, 5, 10	25 F 25 M	<p><u>≤ 10 mg/kg</u>: Dasatinib was not a reproductive toxicant in M and did not affect mating or fertility in F</p> <p><u>≥ 5 mg/kg</u>: Dasatinib induced embryo lethality (post implantation loss of 14 - 48%) in F and associated decreases in litter size.</p>
Range finding pre- and post- natal development study in rats	Oral gavage	GD16, to LD 20 GD21 to LD 20 LD4 to LD 20	0, 5, 10	8F 8F 8F	<p><u>5 mg/kg cohorts starting on GD 16 and 21</u>: Profound pup mortality with associated decreases in litter sizes. Pleural effusion in 20 of 47 and 16 of 42 pups in cohorts starting on GD 16 and GD 21, respectively.</p> <p><u>10 mg/kg all cohorts</u> : Profound pup mortality with associated decreases in litter sizes. Pleural effusion in 30 of 30 and 25 of 57 pups in cohorts starting on GD 21 and LD4, respectively.</p>

Safety Pharmacology

Dasatinib had no significant effects in an *in vitro* ligand binding study. In the hERG/IKr assay, dasatinib inhibited hERG currents by 6, 37, and 77% at 3, 10, and 30 μM , respectively. The IC_{50} was 14.3 μM . In the Purkinje fiber assay, dasatinib prolonged APD_{50} by 26% and APD_{90} by 11% at 30 μM . Dasatinib at a single oral dose of 10 mg/kg in conscious, unrestrained monkeys ($n = 6$) elicited increases in blood pressure (6-15% in systolic and 8-21% in diastolic) for approximately 2 hours. In addition, mean QTc interval increases of 16-19 msec were observed between 1.5 – 2.5 hours post dose in the dasatinib-treated cohort compared to the vehicle control. Although these QTc changes were not statistically significant from control, an association of these changes with dasatinib treatment can not be excluded.

The N-dealkylated metabolite of dasatinib, BMS-582691 at 10 μM inhibited receptor-ligand binding to the adrenergic β_2 , non-selective adrenergic α_2 , non-selective serotonin 5-HT₁, serotonin 5-HT_{1A}, norepinephrine transporter, and dopamine transporter receptors, and to the sodium channel. In the hERG/IKr assay, BMS-582691 inhibited hERG currents with a calculated IC_{50} of 5.8 μM compared to 14.3 μM for dasatinib. In the Purkinje fiber assay, BMS-582691 at 30 μM prolonged APD_{50} and APD_{90} by 10% and 9%, respectively, and reduced V_{max} by 11%.

Study Type / Organ Systems Evaluated	Test System / Species/Strain	Route	Concentration/ Dose	N/Dose/ Sex	Findings
Receptor and Ion Channel Ligand Binding Study	Receptors, ion channels, and enzyme systems	<i>in vitro</i>	10 μM	--	No biologically significant effect on binding of ligands to receptors or ion-channels, or on acetylcholinesterase activity. BMS-582691 at 10 μM inhibited receptor-ligand binding to the adrenergic β_2 (50%), non-selective adrenergic α_2 (51%), non-selective serotonin 5-HT ₁ (50%), serotonin 5-HT _{1A} (54%), norepinephrine transporter (54%), and dopamine transporter (87%) receptors, and to the sodium channel (84%)
hERG/IKr Channel Assay / Cardiovascular	HEK293 cells transfected with human hERG cDNA	<i>in vitro</i>	3, 10, 30 μM	--	Dasatinib: IKr currents were inhibited by 6, 37, and 77% at 3, 10 and 30 μM , respectively. The calculated IC_{50} was 14.3 μM . BMS-582691 inhibited IKr currents by 24, 72, and 95% at 3, 10 and 30 μM , respectively. The calculated IC_{50} was 5.8 μM
Rabbit Purkinje Fiber Action Potential Assay/ Cardiovascular	Rabbit Purkinje fibers	<i>in vitro</i>	3, 10, 30 μM	--	Dasatinib: APD_{50} and APD_{90} were prolonged by 26% and 11%, respectively, at 30 μM . BMS-582691: APD_{50} and APD_{90} were prolonged by 10% and 9%,

Study Type / Organ Systems Evaluated	Test System / Species/Strain	Route	Concentration/ Dose	N/Dose/ Sex	Findings
					respectively, and Vmax was reduced by 11%.
Single-Dose Safety Pharmacology / Cardiovascular	Monkey / Cynomolgus	Oral, single dose	10 mg/kg	3 M 3 F	Drug-related increases in systolic (6-15%) and diastolic (8-21%) blood pressure for approximately 2 hours and mean QTc increases of 16-19 msec between 1.5 – 2.5 hours following a single oral dose.

Other Toxicity Studies

The immunosuppressive potential of dasatinib was assessed in mouse models of T-cell proliferation (mixed lymphocyte response) and nonvascularized heart transplant rejection. The effects of dasatinib on in vitro platelet function were assessed in human, monkey, and rat plasma, and the effects on in vivo bleeding time were assessed in rats. The in vitro phototoxicity potential of dasatinib was assessed in mouse fibroblasts.

The effect of dasatinib on the cardiac sarcoplasmic reticulum and mitochondrial function is unknown. The potential for apoptosis in cardiomyocytes with dasatinib treatment has not been investigated, and no studies have been conducted with dasatinib to evaluate the potential signaling mechanism regulating cardiotoxicity.

Other Toxicity Studies

Study Type / Test System	Route of Administration	Duration of Dosing	Dose (mg/kg)	N/Dose/ Sex	Findings
Mixed Lymphocyte Response Assay/Mouse	Oral gavage	3 days	5, 20, 50	3 M	<u>5 mg/kg</u> : No effect on T-cell proliferation. <u>≥ 20 mg/kg</u> : Dose-dependent inhibition of splenic T-cell proliferation.
Cardiac Transplant Study/Mouse	Oral gavage	30 days	15, 25, 50	4-5 M	<u>15 mg/kg, twice daily (continuous daily dosing)</u> : Graft rejection not inhibited. <u>25 mg/kg, twice daily (5-days on, 2-days off schedule)</u> : Graft rejection not inhibited. <u>25 mg/kg, twice daily, (continuous daily dosing)</u> : Inhibition of graft rejection.
Platelet Function / Platelets from humans, cynomolgus monkeys, and rats	In vitro	--	0.05, 0.5, 5 µg/mL	--	<u>0.05 µg/mL</u> : No effect. <u>0.5 and 5 µg/mL</u> : Inhibition of the platelet aggregation response to ADP and collagen in human platelet-rich plasma, and inhibition of shear-induced aggregation of human platelets. <u>5 µg/mL</u> : Decreased strength of human whole blood clots (29%); no effect on time to clot formation or rate of clot formation. In each species complete inhibition of the collagen response was observed with comparable IC50 values (µg/mL) for human (0.24 ± 0.06) and cynomolgus monkey (0.23 ± 0.06), and slightly but not significantly greater potency for rat (0.13 ± 0.01).
Bleeding Time and Platelet Function/Rat	Oral gavage or IV	Single oral dose or IV infusion	4, 8, 20 (mg/kg, oral) or 630, 1260, 2520 (µg/kg, IV)	5-9 M	<u>Oral gavage</u> : <u>4 mg/kg</u> : No effect on mesenteric bleeding time, cuticle bleeding time, or ADP-induced platelet aggregation. <u>8 mg/kg</u> : No effect on mesenteric bleeding time. The anticipated plasma concentration was not reached for evaluating the cuticle bleeding time and platelet aggregation. <u>20 mg/kg</u> : 3-fold increase in cuticle bleeding time and inhibition of the platelet aggregation response (21 and 99%) induced by 10 µM ADP and 20 µg/mL collagen, respectively. <u>IV infusion</u> : Dasatinib produced dose-dependent increases in cuticle bleeding time at all doses (mean plasma concentrations as 61, 144, 273 ng/mL respectively) and proportion of vessels with re-bleeds and off scale bleeding at the high dose. A dose-dependent reduction in platelet aggregation (37%, 99% and 100%) was also observed at all doses.

Study Type / Test System	Route of Administration	Duration of Dosing	Dose (mg/kg)	N/Dose/ Sex	Findings
Phototoxicity Assay/Mouse fibroblasts	In vitro	--	0.353- 120 µg/mL	--	Results indicated that dasatinib is phototoxic <i>in vitro</i> to mouse fibroblasts

Carcinogenicity

In a 2-year carcinogenicity study, rats were administered oral doses of dasatinib at 0.3, 1, and 3 mg/kg/day. The highest dose resulted in a plasma drug exposure (AUC) levels generally equivalent to the human exposure at the recommended starting dose of 100 mg daily. A statistically significant increase in the combined incidence of squamous cell carcinomas and papillomas in the uterus and cervix of high-dose females ($P = 0.0031$) and of prostate adenoma in low-dose males ($P = 0.0088$; when the intermediate- and high-doses were excluded from the analysis due to increased incidence of mortality at these dose levels) was noted.

REFERENCES

1. ONS Clinical Practice Committee. Cancer Chemotherapy Guidelines and Recommendations for Practice. Pittsburgh, PA: Oncology Nursing Society; 1999:32-41.
2. Recommendations for the Safe Handling of Parenteral Antineoplastic Drugs. Washington, DC: Division of Safety, Clinical Center Pharmacy Department and Cancer Nursing Services, National Institutes of Health; 1992. US Dept of Health and Human Services, Public Health Service Publication NIH 92-2621.
3. AMA Council on Scientific Affairs. Guidelines for Handling Parenteral Antineoplastics. JAMA. 1985; 253:1590-1592.
4. American Society of Hospital Pharmacists. ASHP Technical Assistance Bulletin on Handling Cytotoxic and Hazardous Drugs. Am J Hosp Pharm. 1990; 47: 1033-1049.
5. Controlling Occupational Exposure to Hazardous Drugs. (OSHA Work-Practice Guidelines). Am J Health-Syst Pharm. 1996; 53:1669-1685.
6. NIOSH Alert: Preventing Occupational Exposures to Antineoplastic and Other Hazardous Drugs in Health Care Settings. Department of Health and Human Services, Centers for Disease Control and Prevention, National Institute for Occupational Health and Safety, Publication number 2004-165. September, 2004.
7. O'Hare, In vitro activity of Bcr- Abl inhibitors AMN107 and BMS-354825 against clinically relevant imatinib-resistant Abl kinase domain mutants. Cancer Res. 2005; 65:4500-5.
8. Baccarani M, Saglio G, Goldman J, Hochhaus A, Simonsson B, Appelbaum F, Apperley J, Cervantes F, Cortes J, Deininger M, Gratwohl A, Guilhot F, Horowitz M, Hughes T, Kantarjian H, Larson R, Niederwieser D, Silver R, Hehlmann R; European LeukemiaNet. Evolving concepts in the management of chronic myeloid leukemia: recommendations from an expert panel on behalf of the European LeukemiaNet. Blood. 2006 Sep 15;108(6):1809-20.
9. Kantarjian H, Shah NP, Hochhaus A, Cortes J, Shah S, Ayala M, Moiraghi B, Shen Z, Mayer J, Pasquini R, Nakamae H, Huguet F, Boqué C, Chuah C, Bleickardt E, Bradley-Garelik MB, Zhu C, Sztatrowski T, Shapiro D, Baccarani M. Dasatinib versus imatinib in newly diagnosed chronic-phase chronic myeloid leukemia. N Engl J Med. 2010 Jun 17;362(24):2260-70.

READ THIS FOR SAFE AND EFFECTIVE USE OF YOUR MEDICINE
PATIENT MEDICATION INFORMATION

PRSPRYCEL®
dasatinib tablets

Read this carefully before you start taking **SPRYCEL** and each time you get a refill. This leaflet is a summary and will not tell you everything about this drug. Talk to your healthcare professional about your medical condition and treatment and ask if there is any new information about **SPRYCEL**.

Serious Warnings and Precautions

Take **SPRYCEL** only under the care of a doctor who knows how to use anti-cancer drugs.

Serious and common side effects with **SPRYCEL** include:

- **Myelosuppression (thrombocytopenia, neutropenia, anemia):** **SPRYCEL** can affect your body's ability to make blood cells. It can cause you to have low blood cell counts.
 - Neutropenia is a low white blood cell count. It can occur with and without a fever and can cause you to get infections.
 - Thrombocytopenia is low platelets in the blood. Platelets help with clotting.
 - Anemia is a low red blood cell count.

Your doctor will do regular blood tests to monitor you for myelosuppression.

- **Bleeding**, which may result in death
- **Fluid retention**
- **Congestive heart failure (CHF):** This is when your heart doesn't pump as well as it should. Signs and symptoms of CHF are shortness of breath, swelling and weight gain, which are usually accompanied in almost all cases by fluid retention and pulmonary edema. Pulmonary edema is when fluid builds up in the lung.
- **Pulmonary Arterial Hypertension:** This is a condition where the blood pressure in the arteries of the lung is high.

What is **SPRYCEL used for?**

SPRYCEL is used to treat adults with certain types of leukemia including:

- Philadelphia chromosome positive (Ph+) chronic myeloid leukemia (CML) in chronic phase that has been recently diagnosed;
- Ph+ CML that is no longer benefiting from other available therapies for CML, including imatinib mesylate;
- Ph+ acute lymphoblastic leukemia (ALL) that no longer responds to other therapies.

How does **SPRYCEL work?**

Leukemia is a cancer that affects different types of white blood cells. In patients with leukemia, these white blood cells are abnormal. They don't work properly and can multiply in an uncontrolled way.

SPRYCEL acts by stopping the activity of proteins in these abnormal white blood cells. This helps to slow the uncontrolled growth of the white blood cells.

What are the ingredients in SPRYCEL?

Medicinal ingredients: dasatinib

Non-medicinal ingredients: Croscarmellose sodium, hydroxypropyl cellulose, lactose monohydrate, magnesium stearate and microcrystalline cellulose. The tablet coating consists of hypromellose, titanium dioxide and polyethylene glycol.

SPRYCEL comes in the following dosage forms:

Tablet: 20, 50, 70, 80, 100 and 140 mg.

Do not use SPRYCEL if:

- You are allergic to dasatinib or to any other ingredients in SPRYCEL. Tell your healthcare provider if you think you have had an allergic reaction to any of these ingredients.
- You are breast-feeding.

SPRYCEL should not be used in children under two years of age.

To help avoid side effects and ensure proper use, talk to your healthcare professional before you take SPRYCEL. Talk about any health conditions or problems you may have, including if you:

- Have a liver problem.
- Have a heart problem, such as an irregular heartbeat or a hereditary disorder of the heart's electrical activity, called long QT syndrome.
- Have or have previously had a hepatitis B infection. This is an infection of the liver. SPRYCEL could cause the hepatitis B virus to become active again, which can lead to death in some cases. Your doctor will check for signs of this infection before starting treatment with SPRYCEL. If the hepatitis B virus is found, you will be monitored closely during and for several months after treatment with SPRYCEL.
- Are lactose intolerant or have one of the following rare hereditary diseases:
 - Galactose intolerance
 - Lapp Lactase deficiency
 - Glucose-galactose malabsorptionThis is because lactose is a non-medicinal ingredient in SPRYCEL.
- Are taking medicines to thin the blood or prevent clots. SPRYCEL may cause bleeding.
- Have muscle aches/pains or weakness, or dark-colored urine.

Other warnings you should know about:

Female patients:

- If you are pregnant or planning to become pregnant there are specific risks you must discuss with your healthcare professional.
- Do not become pregnant while taking SPRYCEL. It may harm your unborn baby or make you lose the pregnancy.
- Use highly effective methods of birth control while taking SPRYCEL. Your healthcare professional can tell you about the types of birth control available to you.
- If you do become pregnant while you are using SPRYCEL, tell your healthcare professional right away.
- SPRYCEL may affect your ability to have a child in the future. Talk to your healthcare

professional if you have questions about this.

Male patients:

- Use highly effective methods of birth control each time you have sex with a woman during your treatment with SPRYCEL.

Blood tests:

During your treatment with SPRYCEL you will need to have blood tests done. These will be done about every 1 to 2 weeks for the first few months of your treatment. You will then need to have these tests repeated once every 1 to 3 months. These tests will tell your healthcare professional how SPRYCEL is affecting your blood. They will also show how well your liver and kidneys are working.

Tell your healthcare professional about all the medicines you take, including any drugs, vitamins, minerals, natural supplements or alternative medicines.

The following may interact with SPRYCEL:

- Medicines used to treat irregular heart beat such as: disopyramide, procainamide, amiodarone, sotalol, ibutilide and flecainide.
- Medicines used to stabilize your mood like benzodiazepine, chlorpromazine, haloperidol and pimozide.
- Medicines used to treat chronic or severe pain like methadone.
- Medicines used to treat malaria like chloroquine.
- A medicine that stimulates stomach and bowel movement called domperidone.
- Medicines used to treat fungal infections, like ketoconazole and itraconazole.
- Medicines used to treat bacterial infections like erythromycin and clarithromycin, quinolone, moxifloxacin.
- A medicine used to treat HIV the virus that causes AIDS like ritonavir, lopinavir and atazanavir.
- A medicine used to treat tuberculosis called rifampicin.
- Medicines used to treat epilepsy like carbamazepine, phenytoin and phenobarbital.
- Medicines used to treat high cholesterol like simvastatin.
- A medicine used to prevent organ rejection or treat autoimmune conditions called cyclosporine.
- Medicines used to treat inflammation like dexamethasone.
- An herbal remedy used to treat depression called St. John's Wort.
- Medicines used to treat severe headaches or migraines like ergotamine and dihydroergotamine.

Do not eat or drink any products or juices that contain grapefruit or grapefruit juice. These can affect how SPRYCEL works.

Avoid taking medicines that neutralise stomach acids. Examples are antacids such as cimetidine, famotidine, ranitidine and omeprazole. If you must use these medicines, take them at least 2 hours before or 2 hours after taking SPRYCEL.

Tell your doctor if you are taking medicines to thin the blood or prevent clots like warfarin sodium or aspirin.

How to take SPRYCEL:

- Exactly as directed by your healthcare professional.
- Once per day, either in the morning or in the evening.
- With or without food, at about the same time each day.
- Swallow whole. Do not crush or cut tablets.

Usual dose:

Your dose of SPRYCEL will depend on the type of leukemia you have.

- Usual starting dose for chronic phase CML: 100 mg once a day.
- Usual starting dose for accelerated or blast crisis CML or Ph+ ALL: 140 mg once a day.

Your healthcare professional may interrupt or change your dose of SPRYCEL if:

- You are taking certain medications,
- You do not tolerate the treatment, or
- Your disease gets worse.

Overdose:

If you take too much SPRYCEL, you may experience side effects including low platelet counts.

If you think you have taken too much SPRYCEL, contact your healthcare professional, hospital emergency department or regional poison control centre immediately, even if there are no symptoms.

Missed Dose:

If you miss a dose of SPRYCEL, wait until it is time for your next dose. Do not take two doses at the same time. Call your healthcare provider or pharmacist if you are not sure what to do.

What are possible side effects from using SPRYCEL?

These are not all the possible side effects you may feel when taking SPRYCEL. If you experience any side effects not listed here, contact your healthcare professional.

- Diarrhea
- Nausea
- Vomiting
- Stomach pain
- Fever
- Headache
- Fatigue
- Skin rash
- Shortness of breath
- Cough
- Upper respiratory tract infection
- Infection
- Pain
- Bone and extremity pain
- Muscle and joint aches

SPRYCEL can cause abnormal blood test results. Your doctor will decide when to test your blood and will interpret the results.

The following have been reported in patients using SPRYCEL: inflammation of the lungs, blood clots, irregular heart rhythm, and deaths from gastrointestinal bleeding. These may or may not have been related to SPRYCEL.

Serious side effects and what to do about them			
Symptom / effect	Talk to your healthcare professional		Stop taking drug and get immediate medical help
	Only if severe	In all cases	
COMMON			
Myelosuppression (low blood cell counts): such as anemia (low red blood cell counts), neutropenia (low white blood cell counts), or thrombocytopenia (low platelet counts)		√	
Bleeding (loss of blood or bruising without having an injury no matter how mild): bleeding; bruising; blood in vomit, stools or urine; or black stools; bleeding from the nose or gums, excessive period bleeding		√	
Fluid retention (build-up of water in your body, which can be in the lining of your lungs or around your heart): swelling anywhere on or in your body, weight gain; shortness of breath, especially after low levels of physical exertion; chest pain when taking a deep breath		√	
Heart problems (Irregular heart rate, heart attack): heartbeat that is abnormally slow, fast or forceful; shortness of breath; dizziness or feeling faint; chest pain accompanied with fatigue, nausea or cold sweats			√
Infections (bacterial or viral illness): fever, severe chills, discharge (fluid) with mucus or pus		√	

Serious side effects and what to do about them			
Symptom / effect	Talk to your healthcare professional		Stop taking drug and get immediate medical help
	Only if severe	In all cases	
UNCOMMON			
Liver damage (inflammation of the liver, increased liver enzyme levels on blood tests): yellow skin and/or eyes, nausea, loss of appetite, dark-coloured urine		√	
Rhabdomyolysis (breakdown of damaged muscle); muscle aches and pain, weakness, dark urine		√	
RARE			
Pulmonary arterial hypertension (increased blood pressure in the arteries supplying the lungs): shortness of breath, fatigue		√	
VERY RARE			
Stevens-Johnson syndrome (severe skin reaction): redness, blistering and/or peeling of the skin or mucous membranes (skin of lips, eyes, mouth, nasal passages, genitals) with fever, sore mouth or throat; can lead to death			√
Hepatitis B virus reactivation (an active viral infection of the liver): Weight loss, fever, abdominal pain, nausea and vomiting followed by jaundice (yellowing of the skin or whites of eyes)		√	
Erythema multiforme (severe skin reaction): raised red or purple skin patches with itching or burning, sores with puss			√
Thrombotic microangiopathy (damage to blood vessels): Bruising, bleeding, weakness, fever, fatigue and confusion.			√

If you have a troublesome symptom or side effect that is not listed here or becomes bad enough to interfere with your daily activities, talk to your healthcare professional.

Reporting Side Effects

You can report any suspected side effects associated with the use of health products to Health Canada by:

- Visiting the Web page on Adverse Reaction Reporting (<https://www.canada.ca/en/health-canada/services/drugs-health-products/medeffect-canada/adverse-reaction-reporting.html>) for information on how to report online, by mail or by fax; or
- Calling toll-free at 1-866-234-2345.

NOTE: Contact your health professional if you need information about how to manage your side effects. The Canada Vigilance Program does not provide medical advice.

Storage:

Store at room temperature between 15°C to 30°C.

Keep out of reach and sight of children.

Do not use SPRYCEL after the expiry date written on the label, blister or carton after EXP.

If you want more information about SPRYCEL:

- Talk to your healthcare professional
- Find the full product monograph that is prepared for healthcare professionals and includes this Patient Medication Information by visiting the Health Canada website (<http://hc-sc.gc.ca/index-eng.php>); the manufacturer's website <https://bms.com/ca/en>, or by calling 1-866-463-6267.

This leaflet was prepared by Bristol-Myers Squibb Canada Co., Montreal, Canada H4S 0A4.

Last Revised August 25, 2020

® SPRYCEL is a registered trademark of Bristol-Myers Squibb Holdings Ireland used under licence by Bristol-Myers Squibb Canada Co.

HIGHLIGHTS OF PRESCRIBING INFORMATION

These highlights do not include all the information needed to use SPRYCEL® safely and effectively. See full prescribing information for SPRYCEL.

SPRYCEL (dasatinib) tablets, for oral use

Initial U.S. Approval: 2006

RECENT MAJOR CHANGES

Indications and Usage (1)	12/2018
Dosage and Administration (2)	12/2018
Warnings and Precautions (5)	12/2018

INDICATIONS AND USAGE

SPRYCEL is a kinase inhibitor indicated for the treatment of

- newly diagnosed adults with Philadelphia chromosome-positive (Ph+) chronic myeloid leukemia (CML) in chronic phase. (1, 14)
- adults with chronic, accelerated, or myeloid or lymphoid blast phase Ph+ CML with resistance or intolerance to prior therapy including imatinib. (1, 14)
- adults with Philadelphia chromosome-positive acute lymphoblastic leukemia (Ph+ ALL) with resistance or intolerance to prior therapy. (1, 14)
- pediatric patients 1 year of age and older with Ph+ CML in chronic phase. (1, 14)
- pediatric patients 1 year of age and older with newly diagnosed Ph+ ALL in combination with chemotherapy. (1, 14)

DOSAGE AND ADMINISTRATION

- Chronic phase CML in adults: 100 mg once daily. (2)
- Accelerated phase CML, myeloid or lymphoid blast phase CML, or Ph+ ALL in adults: 140 mg once daily. (2)
- Chronic phase CML and ALL in pediatrics: starting dose based on body weight. (2)
- Administer orally, with or without a meal. Do not crush, cut, or chew tablets. (2)

DOSAGE FORMS AND STRENGTHS

Tablets: 20 mg, 50 mg, 70 mg, 80 mg, 100 mg, and 140 mg. (3, 16)

CONTRAINDICATIONS

None. (4)

WARNINGS AND PRECAUTIONS

- Myelosuppression and Bleeding Events:** Severe thrombocytopenia, neutropenia, and anemia may occur. Use caution if used concomitantly with medications that inhibit platelet function or anticoagulants. Monitor complete blood counts regularly. Transfuse and interrupt SPRYCEL when indicated. (2.5, 5.1, 5.2, 6.1)
- Fluid Retention:** Fluid retention, sometimes severe, including pleural effusions. Manage with supportive care measures and/or dose modification. (2.5, 5.3, 6.1)

- Cardiac Dysfunction:** Monitor patients for signs or symptoms and treat appropriately. (5.4, 6.1)
- Pulmonary Arterial Hypertension (PAH):** SPRYCEL may increase the risk of developing PAH which may be reversible on discontinuation. Consider baseline risk and evaluate patients for signs and symptoms of PAH during treatment. Stop SPRYCEL if PAH is confirmed. (5.5)
- QT Prolongation:** Use SPRYCEL with caution in patients who have or may develop prolongation of the QT interval. (5.6)
- Severe Dermatologic Reactions:** Individual cases of severe mucocutaneous dermatologic reactions have been reported. (5.7, 6.3)
- Tumor Lysis Syndrome:** Tumor lysis syndrome has been reported. Maintain adequate hydration and correct uric acid levels prior to initiating therapy with SPRYCEL. (5.8)
- Embryo-Fetal Toxicity:** Can cause fetal harm. Advise of potential risk to fetus and avoid pregnancy. (5.9, 8.1, 8.3)
- Effects on Growth and Development in Pediatric Patients:** epiphyses delayed fusion, osteopenia, growth retardation, and gynecomastia have been reported. Monitor bone growth and development in pediatric patients. (5.10, 6.3)

ADVERSE REACTIONS

Most common adverse reactions (≥15%) in patients receiving SPRYCEL as single-agent therapy included myelosuppression, fluid retention events, diarrhea, headache, skin rash, hemorrhage, dyspnea, fatigue, nausea, and musculoskeletal pain. (6)

Most common adverse reactions (≥30%) in pediatric patients receiving SPRYCEL in combination with chemotherapy included mucositis, febrile neutropenia, pyrexia, diarrhea, nausea, vomiting, musculoskeletal pain, abdominal pain, cough, headache, rash, fatigue, constipation, arrhythmia, hypertension, edema, infections (bacterial, viral and fungal), hypotension, decreased appetite, hypersensitivity, dyspnea, epistaxis, peripheral neuropathy, and altered state of consciousness. (6)

To report SUSPECTED ADVERSE REACTIONS, contact Bristol-Myers Squibb at 1-800-721-5072 or FDA at 1-800-FDA-1088 or www.fda.gov/medwatch.

DRUG INTERACTIONS

- Strong CYP3A4 Inhibitors:** Dose reduction may be necessary. (2.3, 7.1)
- Strong CYP3A4 Inducers:** Dose increase may be necessary. (2.3, 7.1)
- Antacids:** Avoid simultaneous administration. (7.1)
- H₂ Antagonists and Proton Pump Inhibitors:** Avoid coadministration. (7.1)

USE IN SPECIFIC POPULATIONS

- Lactation:** Advise women not to breastfeed. (8.2)

See 17 for PATIENT COUNSELING INFORMATION and FDA-approved patient labeling.

Revised: 12/2018

FULL PRESCRIBING INFORMATION: CONTENTS*

1 INDICATIONS AND USAGE

2 DOSAGE AND ADMINISTRATION

- 2.1 Dosage of SPRYCEL in Adult Patients
- 2.2 Dosage of SPRYCEL in Pediatric Patients with CML or Ph+ ALL
- 2.3 Dose Modification
- 2.4 Dose Escalation in Adults with CML and Ph+ ALL, and Pediatric Patients with CML
- 2.5 Dose Adjustment for Adverse Reactions
- 2.6 Duration of Treatment

3 DOSAGE FORMS AND STRENGTHS

4 CONTRAINDICATIONS

5 WARNINGS AND PRECAUTIONS

- 5.1 Myelosuppression
- 5.2 Bleeding-Related Events
- 5.3 Fluid Retention
- 5.4 Cardiovascular Events
- 5.5 Pulmonary Arterial Hypertension
- 5.6 QT Prolongation
- 5.7 Severe Dermatologic Reactions
- 5.8 Tumor Lysis Syndrome
- 5.9 Embryo-Fetal Toxicity
- 5.10 Effects on Growth and Development in Pediatric Patients

6 ADVERSE REACTIONS

- 6.1 Clinical Trials Experience
- 6.2 Additional Pooled Data from Clinical Trials
- 6.3 Postmarketing Experience

7 DRUG INTERACTIONS

- 7.1 Effect of Other Drugs on Dasatinib

8 USE IN SPECIFIC POPULATIONS

- 8.1 Pregnancy
- 8.2 Lactation
- 8.3 Females and Males of Reproductive Potential
- 8.4 Pediatric Use
- 8.5 Geriatric Use

10 OVERDOSAGE

11 DESCRIPTION

12 CLINICAL PHARMACOLOGY

- 12.1 Mechanism of Action
- 12.2 Pharmacodynamics
- 12.3 Pharmacokinetics

13 NONCLINICAL TOXICOLOGY

- 13.1 Carcinogenesis, Mutagenesis, Impairment of Fertility

14 CLINICAL STUDIES

- 14.1 Newly Diagnosed Chronic Phase CML in Adults

- 14.2 Imatinib-Resistant or -Intolerant CML or Ph+ ALL in Adults
- 14.3 CML in Pediatric Patients
- 14.4 Ph+ ALL in Pediatric Patients

15 REFERENCES

16 HOW SUPPLIED/STORAGE AND HANDLING

- 16.1 How Supplied

- 16.2 Storage
- 16.3 Handling and Disposal

17 PATIENT COUNSELING INFORMATION

*Sections or subsections omitted from the full prescribing information are not listed.

FULL PRESCRIBING INFORMATION

1 INDICATIONS AND USAGE

SPRYCEL (dasatinib) is indicated for the treatment of adult patients with

- newly diagnosed Philadelphia chromosome-positive (Ph+) chronic myeloid leukemia (CML) in chronic phase.
- chronic, accelerated, or myeloid or lymphoid blast phase Ph+ CML with resistance or intolerance to prior therapy including imatinib.
- Philadelphia chromosome-positive acute lymphoblastic leukemia (Ph+ ALL) with resistance or intolerance to prior therapy.

SPRYCEL (dasatinib) is indicated for the treatment of pediatric patients 1 year of age and older with

- Ph+ CML in chronic phase.
- newly diagnosed Ph+ ALL in combination with chemotherapy.

2 DOSAGE AND ADMINISTRATION

2.1 Dosage of SPRYCEL in Adult Patients

The recommended starting dosage of SPRYCEL for chronic phase CML in adults is 100 mg administered orally once daily. The recommended starting dosage of SPRYCEL for accelerated phase CML, myeloid or lymphoid blast phase CML, or Ph+ ALL in adults is 140 mg administered orally once daily. Tablets should not be crushed, cut, or chewed; they should be swallowed whole. SPRYCEL can be taken with or without a meal, either in the morning or in the evening.

2.2 Dosage of SPRYCEL in Pediatric Patients with CML or Ph+ ALL

The recommended starting dosage for pediatrics is based on body weight as shown in Table 1. The recommended dose should be administered orally once daily with or without food. Recalculate the dose every 3 months based on changes in body weight, or more often if necessary.

Do not crush, cut or chew tablets. Swallow tablets whole. There are additional administration considerations for pediatric patients who have difficulty swallowing tablets whole [*see Use in Specific Populations (8.4) and Clinical Pharmacology (12.3)*].

Table 1: Dosage of SPRYCEL for Pediatric Patients^a

Body Weight (kg)^b	Daily Dose (mg)
10 to less than 20	40 mg
20 to less than 30	60 mg
30 to less than 45	70 mg
at least 45	100 mg

^a For pediatric patients with Ph+ ALL, begin SPRYCEL therapy on or before day 15 of induction chemotherapy, when diagnosis is confirmed and continue for 2 years.

^b Tablet dosing is not recommended for patients weighing less than 10 kg.

Refer to Section 2.4 for recommendations on dose escalation in adults with CML and Ph+ ALL, and pediatric patients with CML.

2.3 Dose Modification

Strong CYP3A4 Inducers

Avoid the use of concomitant strong CYP3A4 inducers and St. John's wort. If patients must be coadministered a strong CYP3A4 inducer, consider a SPRYCEL dose increase. If the dose of SPRYCEL is increased, monitor the patient carefully for toxicity [*see Drug Interactions (7.1)*].

Strong CYP3A4 Inhibitors

Avoid the use of concomitant strong CYP3A4 inhibitors and grapefruit juice. Recommend selecting an alternate concomitant medication with no or minimal enzyme inhibition potential, if possible. If SPRYCEL must be administered with a strong CYP3A4 inhibitor, consider a dose decrease to:

- 40 mg daily for patients taking SPRYCEL 140 mg daily.
- 20 mg daily for patients taking SPRYCEL 100 mg daily.
- 20 mg daily for patients taking SPRYCEL 70 mg daily.

For patients taking SPRYCEL 60 mg or 40 mg daily, consider interrupting SPRYCEL until the inhibitor is discontinued. Allow a washout period of approximately 1 week after the inhibitor is stopped before reinitiating SPRYCEL.

These reduced doses of SPRYCEL are predicted to adjust the area under the curve (AUC) to the range observed without CYP3A4 inhibitors; however, clinical data are not available with these dose adjustments in patients receiving strong CYP3A4 inhibitors. If SPRYCEL is not tolerated after dose reduction, either discontinue the strong CYP3A4 inhibitor or interrupt SPRYCEL until the inhibitor is discontinued. Allow a washout period of approximately 1 week after the inhibitor is stopped before the SPRYCEL dose is increased [*see Drug Interactions (7.1)*].

2.4 Dose Escalation in Adults with CML and Ph+ ALL, and Pediatric Patients with CML

For adult patients with CML and Ph+ ALL, consider dose escalation to 140 mg once daily (chronic phase CML) or 180 mg once daily (advanced phase CML and Ph+ ALL) in patients who do not achieve a hematologic or cytogenetic response at the recommended starting dosage. For pediatric patients with CML, consider dose escalation to 120 mg once daily (see Table 2 below). Dose escalation is not recommended for pediatric patients with Ph+ ALL, where SPRYCEL is administered in combination with chemotherapy.

Escalate the SPRYCEL dose as shown in Table 2 in pediatric patients with chronic phase CML who do not achieve a hematologic or cytogenetic response at the recommended starting dosage.

Table 2: Dose Escalation for Pediatric CML

Formulation	Dose (maximum dose per day)	
	Starting Dose	Escalation
Tablets	40 mg	50 mg
	60 mg	70 mg
	70 mg	90 mg
	100 mg	120 mg

2.5 Dose Adjustment for Adverse Reactions

Myelosuppression

In clinical studies, myelosuppression was managed by dose interruption, dose reduction, or discontinuation of study therapy. Hematopoietic growth factor has been used in patients with resistant myelosuppression. Guidelines for dose modifications for adult and pediatric patients are summarized in Tables 3 and 4, respectively.

Table 3: Dose Adjustments for Neutropenia and Thrombocytopenia in Adults

Chronic Phase CML (starting dose 100 mg once daily)	ANC* $<0.5 \times 10^9/L$	<ol style="list-style-type: none"> 1. Stop SPRYCEL until ANC $\geq 1.0 \times 10^9/L$ and platelets $\geq 50 \times 10^9/L$. 2. Resume treatment with SPRYCEL at the original starting dose if recovery occurs in ≤ 7 days. 3. If platelets $<25 \times 10^9/L$ or recurrence of ANC $<0.5 \times 10^9/L$ for >7 days, repeat Step 1 and resume SPRYCEL at a reduced dose of 80 mg once daily for second episode. For third episode, further reduce dose to 50 mg once daily (for newly diagnosed patients) or discontinue SPRYCEL (for patients resistant or intolerant to prior therapy including imatinib).
	or Platelets $<50 \times 10^9/L$	

Table 3: Dose Adjustments for Neutropenia and Thrombocytopenia in Adults

<p>Accelerated Phase CML, Blast Phase CML and Ph+ ALL (starting dose 140 mg once daily)</p>	<p>ANC* $<0.5 \times 10^9/L$ or Platelets $<10 \times 10^9/L$</p>	<ol style="list-style-type: none"> 1. Check if cytopenia is related to leukemia (marrow aspirate or biopsy). 2. If cytopenia is unrelated to leukemia, stop SPRYCEL until ANC $\geq 1.0 \times 10^9/L$ and platelets $\geq 20 \times 10^9/L$ and resume at the original starting dose. 3. If recurrence of cytopenia, repeat Step 1 and resume SPRYCEL at a reduced dose of 100 mg once daily (second episode) or 80 mg once daily (third episode). 4. If cytopenia is related to leukemia, consider dose escalation to 180 mg once daily.
---	---	--

*ANC: absolute neutrophil count

Table 4: Dose Adjustments for Neutropenia and Thrombocytopenia in Pediatric Patients with Ph+ CML

		Dose (maximum dose per day)		
		Original Starting Dose	One-Level Dose Reduction	Two-Level Dose Reduction
1. If cytopenia persists for more than 3 weeks, check if cytopenia is related to leukemia (marrow aspirate or biopsy).	Tablets	40 mg	20 mg	**
		60 mg	40 mg	20 mg
2. If cytopenia is unrelated to leukemia, stop SPRYCEL until ANC* $\geq 1.0 \times 10^9/L$ and platelets $\geq 75 \times 10^9/L$ and resume at the original starting dose or at a reduced dose.		70 mg	60 mg	50 mg
		100 mg	80 mg	70 mg
3. If cytopenia recurs, repeat marrow aspirate/biopsy and resume SPRYCEL at a reduced dose.				

*ANC: absolute neutrophil count

** lower tablet dose not available

For pediatric patients with chronic phase CML, if Grade ≥ 3 neutropenia or thrombocytopenia recurs during complete hematologic response (CHR), interrupt SPRYCEL and resume at a reduced dose. Implement temporary dose reductions for intermediate degrees of cytopenia and disease response as needed.

For pediatric patients with Ph+ ALL, if neutropenia and/or thrombocytopenia result in a delay of the next block of treatment by more than 14 days, interrupt SPRYCEL and resume at the same dose level once the next block of treatment is started. If neutropenia and/or thrombocytopenia persist and the next block of treatment is delayed another 7 days, perform a bone marrow assessment to assess cellularity and percentage of blasts. If marrow cellularity is $<10\%$, interrupt treatment with SPRYCEL until ANC $>500/\mu L$ ($0.5 \times 10^9/L$), at which time treatment may be

resumed at full dose. If marrow cellularity is >10%, resumption of treatment with SPRYCEL may be considered.

Non-Hematologic Adverse Reactions

For adults with Ph+ CML and ALL, and pediatric patients with Ph+ CML, if a severe non-hematologic adverse reaction develops with SPRYCEL use, treatment must be withheld until the event has resolved or improved. Thereafter, treatment can be resumed as appropriate at a reduced dose depending on the severity and recurrence of the event [see Warnings and Precautions (5.1)].

For pediatric patients with Ph+ ALL, interrupt treatment for cases of grade ≥ 3 non-hematologic adverse reactions with the exception of liver function test abnormalities, and resume at a reduced dose when resolved to grade ≤ 1 . For elevated direct bilirubin over 5 times the institutional upper limit of normal (ULN), interrupt treatment until improvement to baseline or grade ≤ 1 . For elevated AST/ALT over 15 times the institutional ULN, interrupt treatment until improvement to baseline or grade < 1 . For recurrent liver function test abnormalities as above, reduce the dose if this adverse reaction recurs after reinitiation of SPRYCEL. Dose reduction recommendations are described in Table 5.

Table 5: Dose Adjustments for Non-Hematologic Toxicities in Pediatric Patients

Dose (maximum dose per day)				
	Original Starting Dose	One-Level Dose Reduction	Two-Level Dose Reduction	Dose
1. If a non-hematologic toxicity grade 2 occurs, consider interrupting SPRYCEL if no recovery despite symptomatic therapy; once recovered to grade ≤ 1 , resume at the original starting dose. Resume SPRYCEL at a reduced dose for recurrent events.	Tablets 40 mg	20 mg	**	
	60 mg	40 mg	20 mg	
	70 mg	60 mg	50 mg	
	100 mg	80 mg	70 mg	
2. If a non-hematologic toxicity grade 3 occurs, stop SPRYCEL until recovery to grade ≤ 1 and then resume at a reduced dose.				
3. If direct bilirubin is >5 ULN or AST/ALT >15 ULN, interrupt SPRYCEL until recovery to grade ≤ 1 and then resume SPRYCEL at the original starting dose. Resume SPRYCEL at a reduced dose for recurrent events.				

** lower tablet dose not available

2.6 Duration of Treatment

In clinical studies, treatment with SPRYCEL in adults and in pediatric patients with chronic phase CML was continued until disease progression or until no longer tolerated by the patient. The effect of stopping treatment on long-term disease outcome after the achievement of a cytogenetic response (including complete cytogenetic response [CCyR]) or major molecular response (MMR and MR4.5) has not been established.

In clinical studies, treatment with SPRYCEL in pediatric patients with Ph+ ALL was administered for a maximum duration of 2 years [see *Dosage and Administration (2.2) and Clinical Studies (14.4)*].

SPRYCEL is an antineoplastic product. Follow applicable special handling and disposal procedures.¹

3 DOSAGE FORMS AND STRENGTHS

SPRYCEL (dasatinib) Tablets are available as 20-mg, 50-mg, 70-mg, 80-mg, 100-mg, and 140-mg white to off-white, biconvex, film-coated tablets [see *How Supplied (16.1)*].

4 CONTRAINDICATIONS

None.

5 WARNINGS AND PRECAUTIONS

5.1 Myelosuppression

Treatment with SPRYCEL is associated with severe (NCI CTCAE Grade 3 or 4) thrombocytopenia, neutropenia, and anemia, which occur earlier and more frequently in patients with advanced phase CML or Ph+ ALL than in patients with chronic phase CML.

In patients with chronic phase CML, perform complete blood counts (CBCs) every 2 weeks for 12 weeks, then every 3 months thereafter, or as clinically indicated. In patients with advanced phase CML or Ph+ ALL, perform CBCs weekly for the first 2 months and then monthly thereafter, or as clinically indicated.

In pediatric patients with Ph+ ALL treated with SPRYCEL in combination with chemotherapy, perform CBCs prior to the start of each block of chemotherapy and as clinically indicated. During the consolidation blocks of chemotherapy, perform CBCs every 2 days until recovery.

Myelosuppression is generally reversible and usually managed by withholding SPRYCEL temporarily and/or dose reduction [see *Dosage and Administration (2.5) and Adverse Reactions (6.1)*].

5.2 Bleeding-Related Events

SPRYCEL can cause serious and fatal bleeding. In all CML or Ph+ ALL clinical studies, Grade ≥ 3 central nervous system (CNS) hemorrhages, including fatalities, occurred in <1% of patients receiving SPRYCEL. The incidence of Grade 3/4 hemorrhage, occurred in 5.8% of adult patients and generally required treatment interruptions and transfusions. The incidence of Grade 5 hemorrhage occurred in 0.4% of adult patients. The most frequent site of hemorrhage was

gastrointestinal. Most bleeding events in clinical studies were associated with severe thrombocytopenia. In addition to causing thrombocytopenia in human subjects, dasatinib caused platelet dysfunction *in vitro*.

Concomitant medications that inhibit platelet function or anticoagulants may increase the risk of hemorrhage.

5.3 Fluid Retention

SPRYCEL may cause fluid retention. After 5 years of follow-up in the adult randomized newly diagnosed chronic phase CML study (n=258), Grade 3 or 4 fluid retention was reported in 5% of patients, including 3% of patients with Grade 3 or 4 pleural effusion. In adult patients with newly diagnosed or imatinib-resistant or -intolerant chronic phase CML, Grade 3 or 4 fluid retention occurred in 6% of patients treated with SPRYCEL at the recommended dose (n=548). In adult patients with advanced phase CML or Ph+ ALL treated with SPRYCEL at the recommended dose (n=304), Grade 3 or 4 fluid retention was reported in 8% of patients, including Grade 3 or 4 pleural effusion reported in 7% of patients. In pediatric patients with chronic phase CML, cases of Grade 1 or 2 fluid retention were reported in 10.3% of patients.

Evaluate patients who develop symptoms of pleural effusion or other fluid retention, such as new or worsened dyspnea on exertion or at rest, pleuritic chest pain, or dry cough, promptly with a chest x-ray or additional diagnostic imaging as appropriate. Fluid retention events were typically managed by supportive care measures that may include diuretics or short courses of steroids. Severe pleural effusion may require thoracentesis and oxygen therapy. Consider dose reduction or treatment interruption [*see Dosage and Administration (2.5) and Adverse Reactions (6.1)*].

5.4 Cardiovascular Events

SPRYCEL can cause cardiac dysfunction. After 5 years of follow-up in the randomized newly diagnosed chronic phase CML trial in adults (n=258), the following cardiac adverse reactions occurred: cardiac ischemic events (3.9% dasatinib vs 1.6% imatinib), cardiac-related fluid retention (8.5% dasatinib vs 3.9% imatinib), and conduction system abnormalities, most commonly arrhythmia and palpitations (7.0% dasatinib vs 5.0% imatinib). Two cases (0.8%) of peripheral arterial occlusive disease occurred with imatinib and 2 (0.8%) transient ischemic attacks occurred with dasatinib. Monitor patients for signs or symptoms consistent with cardiac dysfunction and treat appropriately.

5.5 Pulmonary Arterial Hypertension

SPRYCEL may increase the risk of developing pulmonary arterial hypertension (PAH) in adult and pediatric patients which may occur any time after initiation, including after more than 1 year of treatment. Manifestations include dyspnea, fatigue, hypoxia, and fluid retention. PAH may be reversible on discontinuation of SPRYCEL. Evaluate patients for signs and symptoms of underlying cardiopulmonary disease prior to initiating SPRYCEL and during treatment. If PAH is confirmed, SPRYCEL should be permanently discontinued.

5.6 QT Prolongation

SPRYCEL may increase the risk of prolongation of QTc in patients including those with hypokalemia or hypomagnesemia, patients with congenital long QT syndrome, patients taking antiarrhythmic medicines or other medicinal products that lead to QT prolongation, and cumulative high-dose anthracycline therapy. Correct hypokalemia or hypomagnesemia prior to and during SPRYCEL administration.

5.7 Severe Dermatologic Reactions

Cases of severe mucocutaneous dermatologic reactions, including Stevens-Johnson syndrome and erythema multiforme, have been reported in patients treated with SPRYCEL. Discontinue permanently in patients who experience a severe mucocutaneous reaction during treatment if no other etiology can be identified.

5.8 Tumor Lysis Syndrome

Tumor lysis syndrome has been reported in patients with resistance to prior imatinib therapy, primarily in advanced phase disease. Due to potential for tumor lysis syndrome, maintain adequate hydration, correct uric acid levels prior to initiating therapy with SPRYCEL, and monitor electrolyte levels. Patients with advanced stage disease and/or high tumor burden may be at increased risk and should be monitored more frequently [*see Adverse Reactions (6.2)*].

5.9 Embryo-Fetal Toxicity

Based on limited human data, SPRYCEL can cause fetal harm when administered to a pregnant woman. Adverse pharmacologic effects of SPRYCEL including hydrops fetalis, fetal leukopenia, and fetal thrombocytopenia have been reported with maternal exposure to SPRYCEL. Advise females of reproductive potential to avoid pregnancy, which may include the use of effective contraception, during treatment with SPRYCEL and for 30 days after the final dose [*see Use in Specific Populations (8.1, 8.3)*].

5.10 Effects on Growth and Development in Pediatric Patients

In pediatric trials of SPRYCEL in chronic phase CML after at least 2 years of treatment, adverse reactions associated with bone growth and development were reported in 5 (5.2%) patients, one of which was severe in intensity (Growth Retardation Grade 3). These 5 cases included cases of epiphyses delayed fusion, osteopenia, growth retardation, and gynecomastia [*see Adverse Reactions (6.2) and Use in Specific Populations (8.4)*]. Of these 5 cases, 1 case of osteopenia and 1 case of gynecomastia resolved during treatment.

| Monitor bone growth and development in pediatric patients.

6 ADVERSE REACTIONS

The following clinically significant adverse reactions are discussed in greater detail in other sections of the labeling:

- Myelosuppression [*see Dosage and Administration (2.5) and Warnings and Precautions (5.1)*].

- Bleeding-related events [see *Warnings and Precautions (5.2)*].
- Fluid retention [see *Warnings and Precautions (5.3)*].
- Cardiovascular events [see *Warnings and Precautions (5.4)*].
- Pulmonary arterial hypertension [see *Warnings and Precautions (5.5)*].
- QT prolongation [see *Warnings and Precautions (5.6)*].
- Severe dermatologic reactions [see *Warnings and Precautions (5.7)*].
- Tumor lysis syndrome [see *Warnings and Precautions (5.8)*].
- Effects on growth and development in pediatric patients [see *Warnings and Precautions (5.10)*].

6.1 Clinical Trials Experience

Because clinical trials are conducted under widely varying conditions, adverse reaction rates observed in the clinical trials of a drug cannot be directly compared to rates in the clinical trials of another drug and may not reflect the rates observed in practice.

The data described below reflect exposure to SPRYCEL administered as single-agent therapy at all doses tested in clinical studies (n=2809), including 324 adult patients with newly diagnosed chronic phase CML, 2388 adult patients with imatinib-resistant or -intolerant chronic or advanced phase CML or Ph+ ALL, and 97 pediatric patients with chronic phase CML. The median duration of therapy in a total of 2712 adult patients was 19.2 months (range 0 to 93.2 months). In a randomized trial in patients with newly diagnosed chronic phase CML, the median duration of therapy was approximately 60 months. The median duration of therapy in 1618 adult patients with chronic phase CML was 29 months (range 0 to 92.9 months).

The median duration of therapy in 1094 adult patients with advanced phase CML or Ph+ ALL was 6.2 months (range 0 to 93.2 months).

In two non-randomized trials in 97 pediatric patients with chronic phase CML (51 patients newly diagnosed and 46 patients resistant or intolerant to previous treatment with imatinib), the median duration of therapy was 51.1 months (range 1.9 to 99.6 months).

In the overall population of 2712 adult patients, 88% of patients experienced adverse reactions at some time and 19% experienced adverse reactions leading to treatment discontinuation.

In the randomized trial in adult patients with newly diagnosed chronic phase CML, drug was discontinued for adverse reactions in 16% of patients with a minimum of 60 months of follow-up. After a minimum of 60 months of follow-up, the cumulative discontinuation rate was 39%. Among the 1618 patients with chronic phase CML, drug-related adverse reactions leading to discontinuation were reported in 329 (20.3%) patients; among the 1094 patients with advanced phase CML or Ph+ ALL, drug-related adverse reactions leading to discontinuation were reported in 191 (17.5%) patients.

Among the 97 pediatric subjects, drug-related adverse reactions leading to discontinuation were reported in 1 patient (1%).

Adverse reactions reported in $\geq 10\%$ of adult patients, and other adverse reactions of interest, in a randomized trial in patients with newly diagnosed chronic phase CML at a median follow-up of approximately 60 months are presented in Table 6.

Adverse reactions reported in $\geq 10\%$ of adult patients treated at the recommended dose of 100 mg once daily (n=165), and other adverse reactions of interest, in a randomized dose-optimization trial of patients with chronic phase CML resistant or intolerant to prior imatinib therapy at a median follow-up of approximately 84 months are presented in Table 8.

Adverse reactions reported in $\geq 10\%$ of pediatric patients at a median follow-up of approximately 51.1 months are presented in Table 11.

Drug-related serious adverse reactions (SARs) were reported for 16.7% of adult patients in the randomized trial of patients with newly diagnosed chronic phase CML. Serious adverse reactions reported in $\geq 5\%$ of patients included pleural effusion (5%).

Drug-related SARs were reported for 26.1% of patients treated at the recommended dose of 100 mg once daily in the randomized dose-optimization trial of adult patients with chronic phase CML resistant or intolerant to prior imatinib therapy. Serious adverse reactions reported in $\geq 5\%$ of patients included pleural effusion (10%).

Drug-related SARs were reported for 14.4% of pediatric patients.

Chronic Myeloid Leukemia (CML)

Adverse reactions (excluding laboratory abnormalities) that were reported in at least 10% of adult patients are shown in Table 6 for newly diagnosed patients with chronic phase CML and Tables 8 and 10 for CML patients with resistance or intolerance to prior imatinib therapy.

Table 6: Adverse Reactions Reported in $\geq 10\%$ of Adult Patients with Newly Diagnosed Chronic Phase CML (minimum of 60 months follow-up)

Adverse Reaction	All Grades		Grade 3/4	
	SPRYCEL (n=258)	Imatinib (n=258)	SPRYCEL (n=258)	Imatinib (n=258)
	Percent (%) of Patients			
Fluid retention	38	45	5	1
Pleural effusion	28	1	3	0
Superficial localized edema	14	38	0	<1
Pulmonary hypertension	5	<1	1	0
Generalized edema	4	7	0	0
Pericardial effusion	4	1	1	0
Congestive heart failure/ cardiac dysfunction ^a	2	1	<1	<1
Pulmonary edema	1	0	0	0
Diarrhea	22	23	1	1

Table 6: Adverse Reactions Reported in $\geq 10\%$ of Adult Patients with Newly Diagnosed Chronic Phase CML (minimum of 60 months follow-up)

Adverse Reaction	All Grades		Grade 3/4	
	SPRYCEL (n=258)	Imatinib (n=258)	SPRYCEL (n=258)	Imatinib (n=258)
	Percent (%) of Patients			
Musculoskeletal pain	14	17	0	<1
Rash ^b	14	18	0	2
Headache	14	11	0	0
Abdominal pain	11	8	0	1
Fatigue	11	12	<1	0
Nausea	10	25	0	0
Myalgia	7	12	0	0
Arthralgia	7	10	0	<1
Hemorrhage ^c	8	8	1	1
Gastrointestinal bleeding	2	2	1	0
Other bleeding ^d	6	6	0	<1
CNS bleeding	<1	<1	0	<1
Vomiting	5	12	0	0
Muscle spasms	5	21	0	<1

^a Includes cardiac failure acute, cardiac failure congestive, cardiomyopathy, diastolic dysfunction, ejection fraction decreased, and left ventricular dysfunction.

^b Includes erythema, erythema multiforme, rash, rash generalized, rash macular, rash papular, rash pustular, skin exfoliation, and rash vesicular.

^c Adverse reaction of special interest with <10% frequency.

^d Includes conjunctival hemorrhage, ear hemorrhage, ecchymosis, epistaxis, eye hemorrhage, gingival bleeding, hematoma, hematuria, hemoptysis, intra-abdominal hematoma, petechiae, scleral hemorrhage, uterine hemorrhage, and vaginal hemorrhage.

A comparison of cumulative rates of adverse reactions reported in $\geq 10\%$ of patients with minimum follow-up of 1 and 5 years in a randomized trial of newly diagnosed patients with chronic phase CML treated with SPRYCEL are shown in Table 7.

Table 7: Adverse Reactions Reported in ≥10% of Adult Patients with Newly Diagnosed Chronic Phase CML in the SPRYCEL-Treated Arm (n=258)

Adverse Reaction	Minimum of 1 Year Follow-up		Minimum of 5 Years Follow-up	
	All Grades	Grade 3/4	All Grades	Grade 3/4
	Percent (%) of Patients			
Fluid retention	19	1	38	5
Pleural effusion	10	0	28	3
Superficial localized edema	9	0	14	0
Pulmonary hypertension	1	0	5	1
Generalized edema	2	0	4	0
Pericardial effusion	1	<1	4	1
Congestive heart failure/cardiac dysfunction ^a	2	<1	2	<1
Pulmonary edema	<1	0	1	0
Diarrhea	17	<1	22	1
Musculoskeletal pain	11	0	14	0
Rash ^b	11	0	14	0
Headache	12	0	14	0
Abdominal pain	7	0	11	0
Fatigue	8	<1	11	<1
Nausea	8	0	10	0

^a Includes cardiac failure acute, cardiac failure congestive, cardiomyopathy, diastolic dysfunction, ejection fraction decreased, and left ventricular dysfunction.

^b Includes erythema, erythema multiforme, rash, rash generalized, rash macular, rash papular, rash pustular, skin exfoliation, and rash vesicular.

At 60 months, there were 26 deaths in dasatinib-treated patients (10.1%) and 26 deaths in imatinib-treated patients (10.1%); 1 death in each group was assessed by the investigator as related to study therapy.

Table 8: Adverse Reactions Reported in ≥10% of Adult Patients with Chronic Phase CML Resistant or Intolerant to Prior Imatinib Therapy (minimum of 84 months follow-up)

Adverse Reaction	100 mg Once Daily	
	Chronic (n=165)	
	All Grades	Grade 3/4
	Percent (%) of Patients	
Fluid retention	48	7

Table 8: Adverse Reactions Reported in ≥10% of Adult Patients with Chronic Phase CML Resistant or Intolerant to Prior Imatinib Therapy (minimum of 84 months follow-up)

Adverse Reaction	100 mg Once Daily	
	Chronic (n=165)	
	All Grades	Grade 3/4
	Percent (%) of Patients	
Superficial localized edema	22	0
Pleural effusion	28	5
Generalized edema	4	0
Pericardial effusion	3	1
Pulmonary hypertension	2	1
Headache	33	1
Diarrhea	28	2
Fatigue	26	4
Dyspnea	24	2
Musculoskeletal pain	22	2
Nausea	18	1
Skin rash ^a	18	2
Myalgia	13	0
Arthralgia	13	1
Infection (including bacterial, viral, fungal, and non-specified)	13	1
Abdominal pain	12	1
Hemorrhage	12	1
Gastrointestinal bleeding	2	1
Pruritus	12	1
Pain	11	1
Constipation	10	1

^a Includes drug eruption, erythema, erythema multiforme, erythrodermia, exfoliative rash, generalized erythema, genital rash, heat rash, milia, rash, rash erythematous, rash follicular, rash generalized, rash macular, rash maculopapular, rash papular, rash pruritic, rash pustular, skin exfoliation, skin irritation, urticaria vesiculosa, and rash vesicular.

Cumulative rates of selected adverse reactions that were reported over time in patients treated with the 100 mg once daily recommended starting dose in a randomized dose-optimization trial of imatinib-resistant or -intolerant patients with chronic phase CML are shown in Table 9.

Table 9: Selected Adverse Reactions Reported in Adult Dose Optimization Trial (Imatinib-Intolerant or -Resistant Chronic Phase CML)^a

Adverse Reaction	Minimum of 2 Years Follow-up		Minimum of 5 Years Follow-up		Minimum of 7 Years Follow-up	
	All Grades	Grade 3/4	All Grades	Grade 3/4	All Grades	Grade 3/4
	Percent (%) of Patients					
Diarrhea	27	2	28	2	28	2
Fluid retention	34	4	42	6	48	7
Superficial edema	18	0	21	0	22	0
Pleural effusion	18	2	24	4	28	5
Generalized edema	3	0	4	0	4	0
Pericardial effusion	2	1	2	1	3	1
Pulmonary hypertension	0	0	0	0	2	1
Hemorrhage	11	1	11	1	12	1
Gastrointestinal bleeding	2	1	2	1	2	1

^a Randomized dose-optimization trial results reported in the recommended starting dose of 100 mg once daily (n=165) population.

Table 10: Adverse Reactions Reported in ≥10% of Adult Patients with Advanced Phase CML Resistant or Intolerant to Prior Imatinib Therapy

Adverse Reaction	140 mg Once Daily					
	Accelerated (n=157)		Myeloid Blast (n=74)		Lymphoid Blast (n=33)	
	All Grades	Grade 3/4	All Grades	Grade 3/4	All Grades	Grade 3/4
	Percent (%) of Patients					
Fluid retention	35	8	34	7	21	6
Superficial localized edema	18	1	14	0	3	0
Pleural effusion	21	7	20	7	21	6
Generalized edema	1	0	3	0	0	0
Pericardial effusion	3	1	0	0	0	0
Congestive heart failure/cardiac dysfunction ^a	0	0	4	0	0	0
Pulmonary edema	1	0	4	3	0	0
Headache	27	1	18	1	15	3
Diarrhea	31	3	20	5	18	0

Table 10: Adverse Reactions Reported in ≥10% of Adult Patients with Advanced Phase CML Resistant or Intolerant to Prior Imatinib Therapy

Adverse Reaction	140 mg Once Daily					
	Accelerated (n=157)		Myeloid Blast (n=74)		Lymphoid Blast (n=33)	
	All Grades	Grade 3/4	All Grades	Grade 3/4	All Grades	Grade 3/4
	Percent (%) of Patients					
Fatigue	19	2	20	1	9	3
Dyspnea	20	3	15	3	3	3
Musculoskeletal pain	11	0	8	1	0	0
Nausea	19	1	23	1	21	3
Skin rash ^b	15	0	16	1	21	0
Arthralgia	10	0	5	1	0	0
Infection (including bacterial, viral, fungal, and non-specified)	10	6	14	7	9	0
Hemorrhage	26	8	19	9	24	9
Gastrointestinal bleeding	8	6	9	7	9	3
CNS bleeding	1	1	0	0	3	3
Vomiting	11	1	12	0	15	0
Pyrexia	11	2	18	3	6	0
Febrile neutropenia	4	4	12	12	12	12

^a Includes ventricular dysfunction, cardiac failure, cardiac failure congestive, cardiomyopathy, congestive cardiomyopathy, diastolic dysfunction, ejection fraction decreased, and ventricular failure.

^b Includes drug eruption, erythema, erythema multiforme, erythrosis, exfoliative rash, generalized erythema, genital rash, heat rash, milia, rash, rash erythematous, rash follicular, rash generalized, rash macular, rash maculopapular, rash papular, rash pruritic, rash pustular, skin exfoliation, skin irritation, urticaria vesiculosa, and rash vesicular.

Table 11: Adverse Reactions Reported in ≥10% of Dasatinib-Treated Pediatric Patients with Chronic Phase CML (n=97)

Adverse Reaction	All Grades	Grade 3/4
	Percent (%) of Patients	
Headache	28	3
Nausea	20	0
Diarrhea	21	0
Skin rash	19	0
Vomiting	13	0
Pain in extremity	19	1
Abdominal pain	16	0
Fatigue	10	0
Arthralgia	10	1

Adverse reactions associated with bone growth and development were reported in 5 (5.2%) of pediatric patients with chronic phase CML [see *Warnings and Precautions (5.10)*].

Laboratory Abnormalities

Myelosuppression was commonly reported in all patient populations. The frequency of Grade 3 or 4 neutropenia, thrombocytopenia, and anemia was higher in patients with advanced phase CML than in chronic phase CML (Tables 12 and 13). Myelosuppression was reported in patients with normal baseline laboratory values as well as in patients with pre-existing laboratory abnormalities.

In patients who experienced severe myelosuppression, recovery generally occurred following dose interruption or reduction; permanent discontinuation of treatment occurred in 2% of adult patients with newly diagnosed chronic phase CML and 5% of adult patients with resistance or intolerance to prior imatinib therapy [see *Warnings and Precautions (5.1)*].

Grade 3 or 4 elevations of transaminases or bilirubin and Grade 3 or 4 hypocalcemia, hypokalemia, and hypophosphatemia were reported in patients with all phases of CML but were reported with an increased frequency in patients with myeloid or lymphoid blast phase CML. Elevations in transaminases or bilirubin were usually managed with dose reduction or interruption. Patients developing Grade 3 or 4 hypocalcemia during SPRYCEL therapy often had recovery with oral calcium supplementation.

Laboratory abnormalities reported in adult patients with newly diagnosed chronic phase CML are shown in Table 12. There were no discontinuations of SPRYCEL therapy in this patient population due to biochemical laboratory parameters.

Table 12: CTC Grade 3/4 Laboratory Abnormalities in Adult Patients with Newly Diagnosed Chronic Phase CML (minimum of 60 months follow-up)

	SPRYCEL (n=258)	Imatinib (n=258)
Percent (%) of Patients		
Hematology Parameters		
Neutropenia	29	24
Thrombocytopenia	22	14
Anemia	13	9
Biochemistry Parameters		
Hypophosphatemia	7	31
Hypokalemia	0	3
Hypocalcemia	4	3
Elevated SGPT (ALT)	<1	2
Elevated SGOT (AST)	<1	1
Elevated Bilirubin	1	0
Elevated Creatinine	1	1

CTC grades: neutropenia (Grade 3 ≥ 0.5 – $< 1.0 \times 10^9/L$, Grade 4 $< 0.5 \times 10^9/L$); thrombocytopenia (Grade 3 ≥ 25 – $< 50 \times 10^9/L$, Grade 4 $< 25 \times 10^9/L$); anemia (hemoglobin Grade 3 ≥ 65 – < 80 g/L, Grade 4 < 65 g/L); elevated creatinine (Grade 3 > 3 – $6 \times$ upper limit of normal range (ULN), Grade 4 $> 6 \times$ ULN); elevated bilirubin (Grade 3 > 3 – $10 \times$ ULN, Grade 4 $> 10 \times$ ULN); elevated SGOT or SGPT (Grade 3 > 5 – $20 \times$ ULN, Grade 4 $> 20 \times$ ULN); hypocalcemia (Grade 3 < 7.0 – 6.0 mg/dL, Grade 4 < 6.0 mg/dL); hypophosphatemia (Grade 3 < 2.0 – 1.0 mg/dL, Grade 4 < 1.0 mg/dL); hypokalemia (Grade 3 < 3.0 – 2.5 mmol/L, Grade 4 < 2.5 mmol/L).

Laboratory abnormalities reported in patients with CML resistant or intolerant to imatinib who received the recommended starting doses of SPRYCEL are shown by disease phase in Table 13.

Table 13: CTC Grade 3/4 Laboratory Abnormalities in Clinical Studies of CML in Adults: Resistance or Intolerance to Prior Imatinib Therapy

	Chronic Phase CML 100 mg Once Daily	Advanced Phase CML 140 mg Once Daily		
	(n=165)	Accelerated Phase (n=157)	Myeloid Blast Phase (n=74)	Lymphoid Blast Phase (n=33)
Percent (%) of Patients				
Hematology Parameters*				
Neutropenia	36	58	77	79
Thrombocytopenia	24	63	78	85
Anemia	13	47	74	52
Biochemistry Parameters				
Hypophosphatemia	10	13	12	18
Hypokalemia	2	7	11	15
Hypocalcemia	<1	4	9	12
Elevated SGPT (ALT)	0	2	5	3
Elevated SGOT (AST)	<1	0	4	3
Elevated Bilirubin	<1	1	3	6
Elevated Creatinine	0	2	8	0

CTC grades: neutropenia (Grade 3 ≥ 0.5 – $<1.0 \times 10^9/L$, Grade 4 $<0.5 \times 10^9/L$); thrombocytopenia (Grade 3 ≥ 25 – $<50 \times 10^9/L$, Grade 4 $<25 \times 10^9/L$); anemia (hemoglobin Grade 3 ≥ 65 – <80 g/L, Grade 4 <65 g/L); elevated creatinine (Grade 3 >3 – $6 \times$ upper limit of normal range (ULN), Grade 4 $>6 \times$ ULN); elevated bilirubin (Grade 3 >3 – $10 \times$ ULN, Grade 4 $>10 \times$ ULN); elevated SGOT or SGPT (Grade 3 >5 – $20 \times$ ULN, Grade 4 $>20 \times$ ULN); hypocalcemia (Grade 3 <7.0 – 6.0 mg/dL, Grade 4 <6.0 mg/dL); hypophosphatemia (Grade 3 <2.0 – 1.0 mg/dL, Grade 4 <1.0 mg/dL); hypokalemia (Grade 3 <3.0 – 2.5 mmol/L, Grade 4 <2.5 mmol/L).

* Hematology parameters for 100 mg once-daily dosing in chronic phase CML reflects 60-month minimum follow-up.

Among adult patients with chronic phase CML with resistance or intolerance to prior imatinib therapy, cumulative Grade 3 or 4 cytopenias were similar at 2 and 5 years including: neutropenia (36% vs 36%), thrombocytopenia (23% vs 24%), and anemia (13% vs 13%).

In the pediatric studies in CML, the rates of laboratory abnormalities were consistent with the known profile for laboratory parameters in adults.

Philadelphia Chromosome-Positive Acute Lymphoblastic Leukemia (Ph+ ALL) in Adults

A total of 135 adult patients with Ph+ ALL were treated with SPRYCEL in clinical studies. The median duration of treatment was 3 months (range 0.03–31 months). The safety profile of patients with Ph+ ALL was similar to those with lymphoid blast phase CML. The most frequently reported adverse reactions included fluid retention events, such as pleural effusion (24%) and superficial edema (19%), and gastrointestinal disorders, such as diarrhea (31%), nausea (24%), and vomiting (16%). Hemorrhage (19%), pyrexia (17%), rash (16%), and dyspnea (16%) were also frequently

reported. Serious adverse reactions reported in $\geq 5\%$ of patients included pleural effusion (11%), gastrointestinal bleeding (7%), febrile neutropenia (6%), and infection (5%).

Philadelphia Chromosome-Positive Acute Lymphoblastic Leukemia (Ph+ ALL) in Pediatric Patients

The safety of SPRYCEL administered continuously in combination with multiagent chemotherapy was determined in a multicohort study of 81 pediatric patients with newly diagnosed Ph+ ALL. [see *Clinical Studies (14.4)*]. The median duration of therapy was 24 months (range 2 to 27 months).

Fatal adverse reactions occurred in 3 patients (4%), all of which were due to infections. Eight (10%) patients experienced adverse reactions leading to treatment discontinuation, including fungal sepsis, hepatotoxicity in the setting of graft versus host disease, thrombocytopenia, CMV infection, pneumonia, nausea, enteritis and drug hypersensitivity.

The most common serious adverse reactions (incidence $\geq 10\%$) were pyrexia, febrile neutropenia, mucositis, diarrhea, sepsis, hypotension, infections (bacterial, viral and fungal), hypersensitivity, vomiting, renal insufficiency, abdominal pain, and musculoskeletal pain.

The incidence of common adverse reactions (incidence $\geq 20\%$) on study are shown in Table 14:

Table 14: Adverse Reactions Reported in $\geq 20\%$ of Pediatric Patients with Ph+ ALL Treated with SPRYCEL in Combination with Chemotherapy CA180372 (N=81)

Adverse Reaction	Percent (%) of Patients	
	All Grades	Grade 3/4
Mucositis	93	60
Febrile neutropenia	86	86
Pyrexia	85	17
Diarrhea	84	31
Nausea	84	11
Vomiting	83	17
Musculoskeletal pain	83	25
Abdominal pain	78	17
Cough	78	1

Table 14: Adverse Reactions Reported in $\geq 20\%$ of Pediatric Patients with Ph+ ALL Treated with SPRYCEL in Combination with Chemotherapy CA180372 (N=81)

Headache	77	15
Rash	68	7
Fatigue	59	3
Constipation	57	1
Arrhythmia	47	12
Hypertension	47	10
Edema	47	6
Viral infection	40	12
Hypotension	40	26
Decreased appetite	38	22
Hypersensitivity	36	20
Upper respiratory tract infection	36	10
Dyspnea	35	10
Epistaxis	31	6
Peripheral neuropathy	31	7
Sepsis (excluding fungal)	n/a	31
Altered state of consciousness	30	4
Fungal infection	30	11
Pneumonia (excluding fungal)	28	25
Pruritus	28	
Clostridial infection (excluding sepsis)	25	14
Urinary Tract Infection	24	14

Table 14: Adverse Reactions Reported in $\geq 20\%$ of Pediatric Patients with Ph+ ALL Treated with SPRYCEL in Combination with Chemotherapy CA180372 (N=81)

Bacteremia (excluding fungal)	22	20
Erythema	22	6
Chills	21	-
Pleural effusion	21	9
Sinusitis	21	10
Dehydration	20	9
Renal insufficiency	20	9
Visual impairment	20	

The incidence of common adverse reactions attributed by the investigator to SPRYCEL (reported at a frequency of $\geq 10\%$, all grades and grade 3/4, respectively) on study (N=81), included febrile neutropenia (23%, 23%), nausea (21%, 4%), vomiting (19%, 4%), mucositis (17%, 6%), musculoskeletal pain (17%, 2%), abdominal pain (16%, 5%), diarrhea (16%, 7%), rash (15%, 0%), fatigue (12%, 0%), pyrexia (12%, 6%), and headache (12%, 5%).

CTCAE grade 3/4 laboratory abnormalities in pediatric patients with Ph+ ALL treated with SPRYCEL in combination with chemotherapy are shown in Table 15.

Table 15: CTCAE Grade 3/4 Laboratory Abnormalities in $\geq 10\%$ of Pediatric Patients with Ph+ ALL Treated with SPRYCEL in Combination with Chemotherapy CA180372 (N=81)

Percent (%) of Patients	
Hematology Parameters	
Neutropenia	96
Thrombocytopenia	88
Anemia	82
Biochemistry Parameters	
Elevated SGPT (ALT)	47
Hypokalemia	40

Table 15: CTCAE Grade 3/4 Laboratory Abnormalities in $\geq 10\%$ of Pediatric Patients with Ph+ ALL Treated with SPRYCEL in Combination with Chemotherapy CA180372 (N=81)

	Percent (%) of Patients
Elevated SGOT (AST)	26
Hypocalcemia	19
Hyponatremia	19
Elevated Bilirubin	11
Hypophosphatemia	11

Toxicity grading is per CTCAE version 4.

6.2 Additional Pooled Data from Clinical Trials

The following additional adverse reactions were reported in adult and pediatric patients (n=2809) in SPRYCEL CML clinical studies and adult patients in Ph+ ALL clinical studies at a frequency of $\geq 10\%$, $1\% < 10\%$, $0.1\% < 1\%$, or $< 0.1\%$. These adverse reactions are included based on clinical relevance.

Gastrointestinal Disorders: $1\% < 10\%$ – mucosal inflammation (including mucositis/stomatitis), dyspepsia, abdominal distension, constipation, gastritis, colitis (including neutropenic colitis), oral soft tissue disorder; $0.1\% < 1\%$ – ascites, dysphagia, anal fissure, upper gastrointestinal ulcer, esophagitis, pancreatitis, gastroesophageal reflux disease; $< 0.1\%$ – protein losing gastroenteropathy, ileus, acute pancreatitis, anal fistula.

General Disorders and Administration-Site Conditions: $\geq 10\%$ – peripheral edema, face edema; $1\% < 10\%$ – asthenia, chest pain, chills; $0.1\% < 1\%$ – malaise, other superficial edema, peripheral swelling; $< 0.1\%$ – gait disturbance.

Skin and Subcutaneous Tissue Disorders: $1\% < 10\%$ – alopecia, acne, dry skin, hyperhidrosis, urticaria, dermatitis (including eczema); $0.1\% < 1\%$ – pigmentation disorder, skin ulcer, bullous conditions, photosensitivity, nail disorder, neutrophilic dermatosis, panniculitis, palmar-plantar erythrodysesthesia syndrome, hair disorder; $< 0.1\%$ – leukocytoclastic vasculitis, skin fibrosis.

Respiratory, Thoracic, and Mediastinal Disorders: $1\% < 10\%$ – lung infiltration, pneumonitis, cough; $0.1\% < 1\%$ – asthma, bronchospasm, dysphonia, pulmonary arterial hypertension; $< 0.1\%$ – acute respiratory distress syndrome, pulmonary embolism.

Nervous System Disorders: $1\% < 10\%$ – neuropathy (including peripheral neuropathy), dizziness, dysgeusia, somnolence; $0.1\% < 1\%$ – amnesia, tremor, syncope, balance disorder; $< 0.1\%$ – convulsion, cerebrovascular accident, transient ischemic attack, optic neuritis, VIIIth nerve paralysis, dementia, ataxia.

Blood and Lymphatic System Disorders: 0.1%–<1% – lymphadenopathy, lymphopenia; <0.1% – aplasia pure red cell.

Musculoskeletal and Connective Tissue Disorders: 1%–<10% – muscular weakness, musculoskeletal stiffness; 0.1%–<1% – rhabdomyolysis, tendonitis, muscle inflammation, osteonecrosis, arthritis; <0.1% – epiphyses delayed fusion (reported at 1%–<10% in the pediatric studies), growth retardation (reported at 1%–<10% in the pediatric studies).

Investigations: 1%–<10% – weight increased, weight decreased; 0.1%–<1% – blood creatine phosphokinase increased, gamma-glutamyltransferase increased.

Infections and Infestations: 1%–<10% – pneumonia (including bacterial, viral, and fungal), upper respiratory tract infection/inflammation, herpes virus infection, enterocolitis infection, sepsis (including fatal outcomes [0.2%]).

Metabolism and Nutrition Disorders: 1%–<10% – appetite disturbances, hyperuricemia; 0.1%–<1% – hypoalbuminemia, tumor lysis syndrome, dehydration, hypercholesterolemia; <0.1% – diabetes mellitus.

Cardiac Disorders: 1%–<10% – arrhythmia (including tachycardia), palpitations; 0.1%–<1% – angina pectoris, cardiomegaly, pericarditis, ventricular arrhythmia (including ventricular tachycardia), electrocardiogram T-wave abnormal, troponin increased; <0.1% – cor pulmonale, myocarditis, acute coronary syndrome, cardiac arrest, electrocardiogram PR prolongation, coronary artery disease, pleuropericarditis.

Eye Disorders: 1%–<10% – visual disorder (including visual disturbance, vision blurred, and visual acuity reduced), dry eye; 0.1%–<1% – conjunctivitis, visual impairment, lacrimation increased, <0.1% – photophobia.

Vascular Disorders: 1%–<10% – flushing, hypertension; 0.1%–<1% – hypotension, thrombophlebitis, thrombosis; <0.1% – livedo reticularis, deep vein thrombosis, embolism.

Psychiatric Disorders: 1%–<10% – insomnia, depression; 0.1%–<1% – anxiety, affect lability, confusional state, libido decreased.

Pregnancy, Puerperium, and Perinatal Conditions: <0.1% – abortion.

Reproductive System and Breast Disorders: 0.1%–<1% – gynecomastia, menstrual disorder.

Injury, Poisoning, and Procedural Complications: 1%–<10% – contusion.

Ear and Labyrinth Disorders: 1%–<10% – tinnitus; 0.1%–<1% – vertigo, hearing loss.

Hepatobiliary Disorders: 0.1%–<1% – cholestasis, cholecystitis, hepatitis.

Renal and Urinary Disorders: 0.1%–<1% – urinary frequency, renal failure, proteinuria; <0.1% – renal impairment.

Immune System Disorders: 0.1%–<1% – hypersensitivity (including erythema nodosum).

Endocrine Disorders: 0.1%–<1% – hypothyroidism; <0.1% – hyperthyroidism, thyroiditis.

6.3 Postmarketing Experience

The following additional adverse reactions have been identified during post approval use of SPRYCEL. Because these reactions are reported voluntarily from a population of uncertain size, it is not always possible to reliably estimate their frequency or establish a causal relationship to drug exposure.

Infections: hepatitis B virus reactivation

Cardiac disorders: atrial fibrillation/atrial flutter

Respiratory, thoracic, and mediastinal disorders: interstitial lung disease

Skin and subcutaneous tissue disorders: Stevens-Johnson syndrome

Renal and urinary disorders: nephrotic syndrome

Blood and lymphatic system disorders: thrombotic microangiopathy

7 DRUG INTERACTIONS

7.1 Effect of Other Drugs on Dasatinib

Strong CYP3A4 Inhibitors

The coadministration with strong CYP3A inhibitors may increase dasatinib concentrations [*see Clinical Pharmacology (12.3)*]. Increased dasatinib concentrations may increase the risk of toxicity. Avoid concomitant use of strong CYP3A4 inhibitors. If concomitant administration of a strong CYP3A4 inhibitor cannot be avoided, consider a SPRYCEL dose reduction [*see Dosage and Administration (2.5)*].

Strong CYP3A4 Inducers

The coadministration of SPRYCEL with strong CYP3A inducers may decrease dasatinib concentrations [*see Clinical Pharmacology (12.3)*]. Decreased dasatinib concentrations may reduce efficacy. Consider alternative drugs with less enzyme induction potential. If concomitant administration of a strong CYP3A4 inducer cannot be avoided, consider a SPRYCEL dose increase.

Gastric Acid Reducing Agents

The coadministration of SPRYCEL with a gastric acid reducing agent may decrease the concentrations of dasatinib. Decreased dasatinib concentrations may reduce efficacy.

Do not administer H₂ antagonists or proton pump inhibitors with SPRYCEL. Consider the use of antacids in place of H₂ antagonists or proton pump inhibitors. Administer the antacid at least 2 hours prior to or 2 hours after the dose of SPRYCEL. Avoid simultaneous administration of SPRYCEL with antacids.

8 USE IN SPECIFIC POPULATIONS

8.1 Pregnancy

Risk Summary

Based on limited human data, SPRYCEL can cause fetal harm when administered to a pregnant woman. Adverse pharmacologic effects including hydrops fetalis, fetal leukopenia, and fetal thrombocytopenia have been reported with maternal exposure to SPRYCEL. Animal reproduction studies in rats have demonstrated extensive mortality during organogenesis, the fetal period, and in neonates. Skeletal malformations were observed in a limited number of surviving rat and rabbit conceptuses. These findings occurred at dasatinib plasma concentrations below those in humans receiving therapeutic doses of dasatinib [see *Data*]. Advise a pregnant woman of the potential risk to a fetus.

The estimated background risk in the U.S. general population of major birth defects is 2% to 4% and of miscarriage is 15% to 20% of clinically recognized pregnancies.

Clinical Considerations

Fetal/Neonatal Adverse Reactions

Transplacental transfer of dasatinib has been reported. Dasatinib has been measured in fetal plasma and amniotic fluid at concentrations comparable to those in maternal plasma. Hydrops fetalis, fetal leukopenia, and fetal thrombocytopenia have been reported with maternal exposure to dasatinib. These adverse pharmacologic effects on the fetus are similar to adverse reactions observed in adult patients and may result in fetal harm or neonatal death [see *Warnings and Precautions (5.1, 5.3)*].

Data

Human Data

Based on human experience, dasatinib is suspected to cause congenital malformations, including neural tube defects, and harmful pharmacological effects on the fetus when administered during pregnancy.

Animal Data

In nonclinical studies at plasma concentrations below those observed in humans receiving therapeutic doses of dasatinib, embryo-fetal toxicities were observed in rats and rabbits. Fetal death was observed in rats. In both rats and rabbits, the lowest doses of dasatinib tested (rat: 2.5 mg/kg/day [15 mg/m²/day] and rabbit: 0.5 mg/kg/day [6 mg/m²/day]) resulted in embryo-fetal toxicities. These doses produced maternal AUCs of 105 ng•h/mL and 44 ng•h/mL (0.1-fold the human AUC) in rats and rabbits, respectively. Embryo-fetal toxicities included skeletal malformations at multiple sites (scapula, humerus, femur, radius, ribs, and clavicle), reduced ossification (sternum; thoracic, lumbar, and sacral vertebrae; forepaw phalanges; pelvis; and hyoid body), edema, and microhepatia. In a pre- and postnatal development study in rats, administration of dasatinib from gestation day (GD) 16 through lactation day (LD) 20, GD 21 through LD 20, or LD 4 through LD 20 resulted in extensive pup mortality at maternal exposures that were below the exposures in patients treated with dasatinib at the recommended labeling dose.

8.2 Lactation

Risk Summary

No data are available regarding the presence of dasatinib in human milk, the effects of the drug on the breastfed child, or the effects of the drug on milk production. However, dasatinib is present in the milk of lactating rats. Because of the potential for serious adverse reactions in nursing children from SPRYCEL, breastfeeding is not recommended during treatment with SPRYCEL and for 2 weeks after the final dose.

8.3 Females and Males of Reproductive Potential

Contraception

Females

SPRYCEL can cause fetal harm when administered to a pregnant woman [*see Use in Specific Populations (8.1)*]. Advise females of reproductive potential to avoid pregnancy, which may include the use of effective contraceptive methods, during treatment with SPRYCEL and for 30 days after the final dose.

Infertility

Based on animal data, dasatinib may result in damage to female and male reproductive tissues [*see Nonclinical Toxicology (13.1)*].

8.4 Pediatric Use

Ph+ CML in Chronic Phase

The safety and effectiveness of SPRYCEL monotherapy have been demonstrated in pediatric patients with newly diagnosed chronic phase CML [*see Clinical Studies (14.3)*]. There are no data in children under 1 year of age. Adverse reactions associated with bone growth and development were reported in 5 (5.2%) of patients [*see Warnings and Precautions (5.10)*].

Ph+ ALL

The safety and effectiveness of SPRYCEL in combination with chemotherapy have been demonstrated in pediatric patients one year and over with newly diagnosed Ph+ ALL. Use of SPRYCEL in pediatric patients is supported by evidence from one pediatric study. There are no data in children under 1 year of age. One case of grade 1 osteopenia was reported.

The safety profile of SPRYCEL in pediatric subjects was comparable to that reported in studies in adult subjects [*see Adverse Reactions (6.1) and Clinical Studies (14.3, 14.4)*].

Monitor bone growth and development in pediatric patients [*see Warnings and Precautions (5.10)*].

Pediatric Patients with Difficulty Swallowing Tablets

Five patients with Ph+ ALL 2 to 10 years of age received at least one dose of SPRYCEL tablet dispersed in juice on Study CA180372. The exposure for dispersed tablets was 36% lower as compared to intact tablets in pediatric patients [*see Clinical Pharmacology (12.3)*]. Due to the

limited available clinical data, it is unclear whether dispersing SPRYCEL tablets significantly alters the safety and/or efficacy of SPRYCEL.

8.5 Geriatric Use

Of the 2712 patients in clinical studies of SPRYCEL, 617 (23%) were 65 years of age and older, and 123 (5%) were 75 years of age and older. No differences in confirmed Complete Cytogenetic Response (cCCyR) and MMR were observed between older and younger patients. While the safety profile of SPRYCEL in the geriatric population was similar to that in the younger population, patients aged 65 years and older are more likely to experience the commonly reported adverse reactions of fatigue, pleural effusion, diarrhea, dyspnea, cough, lower gastrointestinal hemorrhage, and appetite disturbance, and more likely to experience the less frequently reported adverse reactions of abdominal distention, dizziness, pericardial effusion, congestive heart failure, hypertension, pulmonary edema, and weight decrease, and should be monitored closely.

10 OVERDOSAGE

Experience with overdose of SPRYCEL in clinical studies is limited to isolated cases. The highest overdosage of 280 mg per day for 1 week was reported in two patients and both developed severe myelosuppression and bleeding. Since SPRYCEL is associated with severe myelosuppression [*see Warnings and Precautions (5.1) and Adverse Reactions (6.1)*], monitor patients who ingest more than the recommended dosage closely for myelosuppression and give appropriate supportive treatment.

Acute overdose in animals was associated with cardiotoxicity. Evidence of cardiotoxicity included ventricular necrosis and valvular/ventricular/atrial hemorrhage at single doses ≥ 100 mg/kg (600 mg/m²) in rodents. There was a tendency for increased systolic and diastolic blood pressure in monkeys at single doses ≥ 10 mg/kg (120 mg/m²).

11 DESCRIPTION

SPRYCEL (dasatinib) is a kinase inhibitor. The chemical name for dasatinib is N-(2-chloro-6-methylphenyl)-2-[[6-[4-(2-hydroxyethyl)-1-piperazinyl]-2-methyl-4-pyrimidinyl]amino]-5-thiazolecarboxamide, monohydrate. The molecular formula is C₂₂H₂₆ClN₇O₂S • H₂O, which corresponds to a formula weight of 506.02 (monohydrate). The anhydrous free base has a molecular weight of 488.01. Dasatinib has the following chemical structure:

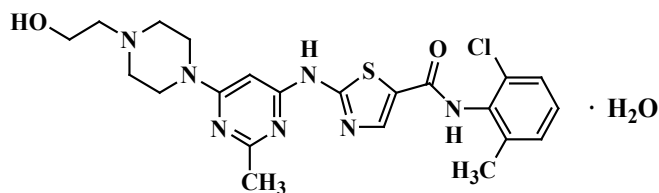

Dasatinib is a white to off-white powder. The drug substance is insoluble in water and slightly soluble in ethanol and methanol.

SPRYCEL tablets are white to off-white, biconvex, film-coated tablets containing dasatinib, with the following inactive ingredients: lactose monohydrate, microcrystalline cellulose, croscarmellose sodium, hydroxypropyl cellulose, and magnesium stearate. The tablet coating consists of hypromellose, titanium dioxide, and polyethylene glycol.

12 CLINICAL PHARMACOLOGY

12.1 Mechanism of Action

Dasatinib, at nanomolar concentrations, inhibits the following kinases: BCR-ABL, SRC family (SRC, LCK, YES, FYN), c-KIT, EPHA2, and PDGFR β . Based on modeling studies, dasatinib is predicted to bind to multiple conformations of the ABL kinase.

In vitro, dasatinib was active in leukemic cell lines representing variants of imatinib mesylate-sensitive and resistant disease. Dasatinib inhibited the growth of chronic myeloid leukemia (CML) and acute lymphoblastic leukemia (ALL) cell lines overexpressing BCR-ABL. Under the conditions of the assays, dasatinib could overcome imatinib resistance resulting from BCR-ABL kinase domain mutations, activation of alternate signaling pathways involving the SRC family kinases (LYN, HCK), and multi-drug resistance gene overexpression.

12.2 Pharmacodynamics

Cardiac Electrophysiology

Of 2440 patients treated with SPRYCEL at all doses tested in clinical trials, 16 patients (<1%) had QTc prolongation reported as an adverse reaction. Twenty-two patients (1%) experienced a QTcF > 500 ms. In 865 patients with leukemia treated with SPRYCEL 70 mg BID in five Phase 2 studies, the maximum mean changes in QTcF (90% upper bound CI) from baseline ranged from 7 ms to 13.4 ms.

An analysis of the data from five Phase 2 studies in patients (70 mg BID) and a Phase 1 study in healthy subjects (100 mg single dose) suggests that there is a maximum increase of 3 to 6 milliseconds in Fridericia corrected QTc interval from baseline for subjects receiving therapeutic doses of dasatinib, with associated upper 95% confidence intervals <10 msec.

12.3 Pharmacokinetics

The pharmacokinetics of dasatinib exhibits dose proportional increases in AUC and linear elimination characteristics over the dose range of 15 mg/day (0.15 times the lowest approved recommended dose) to 240 mg/day (1.7 times the highest approved recommended dose).

At 100 mg QD, the maximum concentration at steady state (C_{max}) is 82.2 ng/mL (CV% 69%), area under the plasma drug concentration time curve (AUC) is 397 ng/mL*hr (CV% 55%). The clearance of dasatinib is found to be time-invariant. When administered to adult healthy subjects as dispersed tablets in juice, the adjusted geometric mean ratio was 0.97 (90% CI: 0.85, 1.10) for C_{max} and 0.84 (90% CI: 0.78, 0.91) for AUC as compared to intact tablets.

Absorption

The maximum plasma concentrations (C_{\max}) of dasatinib are observed between 0.5 hours and 6 hours (T_{\max}) following oral administration.

Food Effect

A high-fat meal increased the mean AUC of dasatinib following a single dose of 100 mg by 14%. The total calorie content of the high-fat meal was 985 kcal. The calories derived from fat, carbohydrates, and protein were 52%, 34%, and 14% for the high-fat meal.

Distribution

The apparent volume of distribution is 2505 L (CV% 93%).

Binding of dasatinib to human plasma proteins *in vitro* was approximately 96% and of its active metabolite was 93%, with no concentration dependence over the range of 100 ng/mL to 500 ng/mL.

Dasatinib is a P-gp substrate *in vitro*.

Elimination

The mean terminal half-life of dasatinib is 3 hours to 5 hours. The mean apparent oral clearance is 363.8 L/hr (CV% 81.3%).

Metabolism

Dasatinib is metabolized in humans, primarily by CYP3A4. CYP3A4 is the primary enzyme responsible for the formation of the active metabolite. Flavin-containing monooxygenase 3 (FMO-3) and uridine diphosphate-glucuronosyltransferase (UGT) enzymes are also involved in the formation of dasatinib metabolites.

The exposure of the active metabolite, which is equipotent to dasatinib, represents approximately 5% of the AUC of dasatinib. The active metabolite of dasatinib is unlikely to play a major role in the observed pharmacology of the drug. Dasatinib also has several other inactive oxidative metabolites.

Excretion

Elimination is primarily via the feces. Following a single radiolabeled dose of oral dasatinib, 4% of the administered radioactivity was recovered in the urine and 85% in the feces within 10 days. Unchanged dasatinib accounted for 0.1% of the administered dose in the urine and 19% of the administered dose in the feces with the remainder of the dose being metabolites.

Specific Populations

Age (15 to 86 years old), sex, and renal impairment (creatinine clearance 21.6 mL/min to 342.3 mL/min as estimated by Cockcroft Gault) have no clinically relevant effect on the pharmacokinetics of dasatinib.

Pediatric Patients

The pharmacokinetics of dasatinib were evaluated in 43 pediatric patients with leukemia or solid tumors at oral doses ranging from 60 mg/m² to 120 mg/m² once daily, taken with or without food.

The pharmacokinetics showed dose proportionality with a dose-related increase in exposure. The mean T_{max} was observed between 0.5 hours and 6 hours and the mean half-life was 2 hours to 5 hours. The geometric mean (CV%) of body weight normalized clearance in these 43 pediatric patients is 5.98 (41.5%) L/h/kg. In pediatric patients with a dosing regimen of 60 mg/m², the model simulated geometric mean (CV%) steady-state plasma average concentrations of dasatinib were 14.7 (64.6%) ng/mL (for 2 to <6 years old), 16.3 (97.5%) ng/mL (for 6 to <12 years old), and 18.2 (67.7%) ng/mL (for 12 years and older) [see *Dosage and Administration* (2.2)]. Dasatinib clearance and volume of distribution change with body weight in pediatric patients. Dasatinib has not been studied in patients < 1 year old.

The bioavailability of dispersed tablets in pediatric patients was estimated to be 36% lower than that of intact tablets.

Patients with Hepatic Impairment

Compared to subjects with normal liver function, patients with moderate hepatic impairment (Child Pugh B) had decreases in mean C_{max} by 47% and mean AUC by 8%. Patients with severe hepatic impairment (Child Pugh C) had decreases in mean C_{max} by 43% and in mean AUC by 28% compared to the subjects with normal liver function.

Drug Interaction Studies

Cytochrome P450 Enzymes

The coadministration of ketoconazole (strong CYP3A4 inhibitor) twice daily increased the mean C_{max} of dasatinib by 4-fold and the mean AUC of dasatinib by 5-fold following a single oral dose of 20 mg.

The coadministration of rifampin (strong CYP3A4 inducer) once daily decreased the mean C_{max} of dasatinib by 81% and the mean AUC of dasatinib by 82%.

Dasatinib is a time-dependent inhibitor of CYP3A4. Dasatinib does not inhibit CYP1A2, 2A6, 2B6, 2C8, 2C9, 2C19, 2D6, or 2E1. Dasatinib does not induce CYP enzymes.

Gastric Acid Reducing Agents

The administration of 30 mL of aluminum hydroxide/magnesium hydroxide 2 hours prior to a single dose of SPRYCEL was associated with no relevant change in the mean AUC of dasatinib; however, the mean C_{max} of dasatinib was increased by 26%.

The simultaneous administration of 30 mL of aluminum hydroxide/magnesium hydroxide with a single dose of SPRYCEL was associated with a 55% reduction in the mean AUC of dasatinib and a 58% reduction in the mean C_{max} of dasatinib.

The administration of a single dose of SPRYCEL 10 hours following famotidine (H₂ antagonist) reduced the mean AUC of dasatinib by 61% and the mean C_{max} of dasatinib by 63%.

The administration of a single 100 mg dose of SPRYCEL 22 hours following a 40 mg dose of omeprazole (proton pump inhibitor) at steady state reduced the mean AUC of dasatinib by 43% and the mean C_{max} of dasatinib by 42%.

Transporters

Dasatinib is a not an inhibitor of P-gp *in vitro*.

13 NONCLINICAL TOXICOLOGY

13.1 Carcinogenesis, Mutagenesis, Impairment of Fertility

In a 2-year carcinogenicity study, rats were administered oral doses of dasatinib at 0.3, 1, and 3 mg/kg/day. The highest dose resulted in a plasma drug exposure (AUC) level approximately 60% of the human exposure at 100 mg once daily. Dasatinib induced a statistically significant increase in the combined incidence of squamous cell carcinomas and papillomas in the uterus and cervix of high-dose females and prostate adenoma in low-dose males.

Dasatinib was clastogenic when tested *in vitro* in Chinese hamster ovary cells, with and without metabolic activation. Dasatinib was not mutagenic when tested in an *in vitro* bacterial cell assay (Ames test) and was not genotoxic in an *in vivo* rat micronucleus study.

Dasatinib did not affect mating or fertility in male and female rats at plasma drug exposure (AUC) similar to the human exposure at 100 mg daily. In repeat dose studies, administration of dasatinib resulted in reduced size and secretion of seminal vesicles, and immature prostate, seminal vesicle, and testis. The administration of dasatinib resulted in uterine inflammation and mineralization in monkeys, and cystic ovaries and ovarian hypertrophy in rodents.

14 CLINICAL STUDIES

14.1 Newly Diagnosed Chronic Phase CML in Adults

DASISION (Dasatinib vs Imatinib Study in Treatment-Naive Chronic Myeloid Leukemia Patients) (NCT00481247) was an open-label, multicenter, international, randomized trial conducted in adult patients with newly diagnosed chronic phase CML. A total of 519 patients were randomized to receive either SPRYCEL 100 mg once daily or imatinib 400 mg once daily. Patients with a history of cardiac disease were included in this trial except those who had a myocardial infarction within 6 months, congestive heart failure within 3 months, significant arrhythmias, or QTc prolongation. The primary endpoint was the rate of confirmed complete cytogenetic response (CCyR) within 12 months. Confirmed CCyR was defined as a CCyR noted on two consecutive occasions (at least 28 days apart).

Median age was 46 years in the SPRYCEL group and 49 years in the imatinib groups, with 10% and 11% of patients ≥ 65 years of age, respectively. There were slightly more male than female patients in both groups (59% vs 41%). Fifty-three percent of all patients were Caucasian and 39% were Asian. At baseline, the distribution of Hasford scores was similar in the SPRYCEL and imatinib treatment groups (low risk: 33% and 34%; intermediate risk: 48% and 47%; high risk: 19% and 19%, respectively). With a minimum of 12 months follow-up, 85% of patients randomized to SPRYCEL and 81% of patients randomized to imatinib were still on study.

With a minimum of 24 months follow-up, 77% of patients randomized to SPRYCEL and 75% of patients randomized to imatinib were still on study and with a minimum of 60 months follow-up, 61% and 62% of patients, respectively, were still on treatment at the time of study closure.

Efficacy results are summarized in Table 16.

Table 16: Efficacy Results in a Randomized Newly Diagnosed Chronic Phase CML Trial

	SPRYCEL (n=259)	Imatinib (n=260)
Confirmed CCyR^a		
Within 12 months (95% CI)	76.8% (71.2–81.8)	66.2% (60.1–71.9)
P-value		0.007*
Major Molecular Response^b		
12 months (95% CI)	52.1% (45.9–58.3)	33.8% (28.1–39.9)
P-value		<0.0001
60 months (95% CI)	76.4% (70.8–81.5)	64.2% (58.1–70.1)

^a Confirmed CCyR is defined as a CCyR noted on two consecutive occasions at least 28 days apart.

^b Major molecular response (at any time) was defined as BCR-ABL ratios $\leq 0.1\%$ by RQ-PCR in peripheral blood samples standardized on the International scale. These are cumulative rates representing minimum follow up for the time frame specified.

* Adjusted for Hasford score and indicated statistical significance at a pre-defined nominal level of significance.
CI = confidence interval.

The confirmed CCyR within 24, 36, and 60 months for SPRYCEL versus imatinib arms were 80% versus 74%, 83% versus 77%, and 83% versus 79%, respectively. The MMR at 24 and 36 months for SPRYCEL versus imatinib arms were 65% versus 50% and 69% versus 56%, respectively.

After 60 months follow-up, median time to confirmed CCyR was 3.1 months in 215 SPRYCEL responders and 5.8 months in 204 imatinib responders. Median time to MMR after 60 months follow-up was 9.3 months in 198 SPRYCEL responders and 15.0 months in 167 imatinib responders.

At 60 months, 8 patients (3%) on the dasatinib arm progressed to either accelerated phase or blast crisis while 15 patients (6%) on the imatinib arm progressed to either accelerated phase or blast crisis.

The estimated 60-month survival rates for SPRYCEL- and imatinib-treated patients were 90.9% (CI: 86.6%–93.8%) and 89.6% (CI: 85.2%–92.8%), respectively. Based on data 5 years after the last patient was enrolled in the trial, 83% and 77% of patients were known to be alive in the dasatinib and imatinib treatment groups, respectively, 10% were known to have died in both treatment groups, and 7% and 13% had unknown survival status in the dasatinib and imatinib treatment groups, respectively.

At 60 months follow-up in the SPRYCEL arm, the rate of MMR at any time in each risk group determined by Hasford score was 90% (low risk), 71% (intermediate risk) and 67% (high risk). In the imatinib arm, the rate of MMR at any time in each risk group determined by Hasford score was 69% (low risk), 65% (intermediate risk), and 54% (high risk).

BCR-ABL sequencing was performed on blood samples from patients in the newly diagnosed trial who discontinued dasatinib or imatinib therapy. Among dasatinib-treated patients the mutations detected were T315I, F317I/L, and V299L.

Dasatinib does not appear to be active against the T315I mutation, based on *in vitro* data.

14.2 Imatinib-Resistant or -Intolerant CML or Ph+ ALL in Adults

The efficacy and safety of SPRYCEL were investigated in adult patients with CML or Ph+ ALL whose disease was resistant to or who were intolerant to imatinib: 1158 patients had chronic phase CML, 858 patients had accelerated phase, myeloid blast phase, or lymphoid blast phase CML, and 130 patients had Ph+ ALL. In a clinical trial in chronic phase CML, resistance to imatinib was defined as failure to achieve a complete hematologic response (CHR; after 3 months), major cytogenetic response (MCyR; after 6 months), or complete cytogenetic response (CCyR; after 12 months); or loss of a previous molecular response (with concurrent $\geq 10\%$ increase in Ph+ metaphases), cytogenetic response, or hematologic response. Imatinib intolerance was defined as inability to tolerate 400 mg or more of imatinib per day or discontinuation of imatinib because of toxicity.

Results described below are based on a minimum of 2 years follow-up after the start of SPRYCEL therapy in patients with a median time from initial diagnosis of approximately 5 years. Across all studies, 48% of patients were women, 81% were white, 15% were black or Asian, 25% were 65 years of age or older, and 5% were 75 years of age or older. Most patients had long disease histories with extensive prior treatment, including imatinib, cytotoxic chemotherapy, interferon, and stem cell transplant. Overall, 80% of patients had imatinib-resistant disease and 20% of patients were intolerant to imatinib. The maximum imatinib dose had been 400–600 mg/day in about 60% of the patients and >600 mg/day in 40% of the patients.

The primary efficacy endpoint in chronic phase CML was MCyR, defined as elimination (CCyR) or substantial diminution (by at least 65%, partial cytogenetic response) of Ph+ hematopoietic cells. The primary efficacy endpoint in accelerated phase, myeloid blast phase, lymphoid blast phase CML, and Ph+ ALL was major hematologic response (MaHR), defined as either a CHR or no evidence of leukemia (NEL).

Chronic Phase CML

Dose-Optimization Trial: A randomized, open-label trial (NCT00123474) was conducted in adult patients with chronic phase CML to evaluate the efficacy and safety of SPRYCEL administered once daily compared with SPRYCEL administered twice daily. Patients with significant cardiac diseases, including myocardial infarction within 6 months, congestive heart failure within 3 months, significant arrhythmias, or QTc prolongation were excluded from the trial. The primary efficacy endpoint was MCyR in patients with imatinib-resistant CML. A total of 670 patients, of whom 497 had imatinib-resistant disease, were randomized to the SPRYCEL 100 mg once-daily, 140 mg once-daily, 50 mg twice-daily, or 70 mg twice-daily group. Median duration of treatment was 22 months.

Efficacy was achieved across all SPRYCEL treatment groups with the once-daily schedule demonstrating comparable efficacy (non-inferiority) to the twice-daily schedule on the primary efficacy endpoint (difference in MCyR 1.9%; 95% CI [-6.8%–10.6%]); however, the 100-mg once-daily regimen demonstrated improved safety and tolerability.

Efficacy results are presented in Tables 17 and 18 for adult patients with chronic phase CML who received the recommended starting dose of 100 mg once daily.

Table 17: Efficacy of SPRYCEL in Adult Patients with Imatinib-Resistant or -Intolerant Chronic Phase CML (minimum of 24 months follow-up)

All Patients	100 mg Once Daily (n=167)
Hematologic Response Rate % (95% CI)	
CHR ^a	92% (86–95)
Cytogenetic Response Rate % (95% CI)	
MCyR ^b	63% (56–71)
CCyR	50% (42–58)

^a CHR (response confirmed after 4 weeks): WBC ≤ institutional ULN, platelets <450,000/mm³, no blasts or promyelocytes in peripheral blood, <5% myelocytes plus metamyelocytes in peripheral blood, basophils in peripheral blood <20%, and no extramedullary involvement.

^b MCyR combines both complete (0% Ph+ metaphases) and partial (>0%–35%) responses.

Table 18: Long-Term MMR of SPRYCEL in the Dose Optimization Trial: Adult Patients with Imatinib-Resistant or -Intolerant Chronic Phase CML^a

	Minimum Follow-up Period		
	2 Years	5 Years	7 Years
Major Molecular Response^b % (n/N)			
All Patients Randomized	34% (57/167)	43% (71/167)	44% (73/167)
Imatinib-Resistant Patients	33% (41/124)	40% (50/124)	41% (51/124)
Imatinib-Intolerant Patients	37% (16/43)	49% (21/43)	51% (22/43)

^a Results reported in recommended starting dose of 100 mg once daily.

^b Major molecular response criteria: Defined as BCR-ABL/control transcripts ≤0.1% by RQ-PCR in peripheral blood samples.

Based on data 7 years after the last patient was enrolled in the trial, 44% were known to be alive, 31% were known to have died, and 25% had an unknown survival status.

By 7 years, transformation to either accelerated or blast phase occurred in nine patients on treatment in the 100 mg once-daily treatment group.

Advanced Phase CML and Ph+ ALL

Dose-Optimization Trial: One randomized open-label trial (NCT00123487) was conducted in patients with advanced phase CML (accelerated phase CML, myeloid blast phase CML, or lymphoid blast phase CML) to evaluate the efficacy and safety of SPRYCEL administered once daily compared with SPRYCEL administered twice daily. The primary efficacy endpoint was MaHR. A total of 611 patients were randomized to either the SPRYCEL 140 mg once-daily or 70 mg twice-daily group. Median duration of treatment was approximately 6 months for both treatment groups. The once-daily schedule demonstrated comparable efficacy (non-inferiority) to the twice-daily schedule on the primary efficacy endpoint; however, the 140-mg once-daily regimen demonstrated improved safety and tolerability.

Response rates for patients in the 140 mg once-daily group are presented in Table 19.

Table 19: Efficacy of SPRYCEL in Imatinib-Resistant or -Intolerant Advanced Phase CML and Ph+ ALL (2-Year Results)

	140 mg Once Daily			
	Accelerated (n=158)	Myeloid Blast (n=75)	Lymphoid Blast (n=33)	Ph+ ALL (n=40)
MaHR^a (95% CI)	66% (59–74)	28% (18–40)	42% (26–61)	38% (23–54)
CHR^a (95% CI)	47% (40–56)	17% (10–28)	21% (9–39)	33% (19–49)
NEL^a (95% CI)	19% (13–26)	11% (5–20)	21% (9–39)	5% (1–17)
MCyR^b (95% CI)	39% (31–47)	28% (18–40)	52% (34–69)	70% (54–83)
CCyR (95% CI)	32% (25–40)	17% (10–28)	39% (23–58)	50% (34–66)

^a Hematologic response criteria (all responses confirmed after 4 weeks): Major hematologic response: (MaHR) = complete hematologic response (CHR) + no evidence of leukemia (NEL).

CHR: WBC ≤ institutional ULN, ANC ≥1000/mm³, platelets ≥100,000/mm³, no blasts or promyelocytes in peripheral blood, bone marrow blasts ≤5%, <5% myelocytes plus metamyelocytes in peripheral blood, basophils in peripheral blood <20%, and no extramedullary involvement.

NEL: same criteria as for CHR but ANC ≥500/mm³ and <1000/mm³, or platelets ≥20,000/mm³ and ≤100,000/mm³.

^b MCyR combines both complete (0% Ph+ metaphases) and partial (>0%–35%) responses.

CI = confidence interval ULN = upper limit of normal range.

In the SPRYCEL 140 mg once-daily group, the median time to MaHR was 1.9 months (min-max: 0.7-14.5) for patients with accelerated phase CML, 1.9 months (min-max: 0.9-6.2) for patients with myeloid blast phase CML, and 1.8 months (min-max: 0.9-2.8) for patients with lymphoid blast phase CML.

In patients with myeloid blast phase CML, the median duration of MaHR was 8.1 months (min-max: 2.7-21.1) and 9.0 (min-max: 1.8-23.1) months for the 140 mg once-daily group and the

70 mg twice-daily group, respectively. In patients with lymphoid blast phase CML, the median duration of MaHR was 4.7 months (min-max: 3.0-9.0) and 7.9 months (min-max: 1.6-22.1) for the 140 mg once-daily group and the 70 mg twice-daily group, respectively. In patients with Ph+ ALL who were treated with SPRYCEL 140 mg once-daily, the median duration of MaHR was 4.6 months (min-max: 1.4-10.2). The medians of progression-free survival for patients with Ph+ ALL treated with SPRYCEL 140 mg once-daily and 70 mg twice-daily were 4.0 months (min-max: 0.4-11.1) and 3.1 months (min-max: 0.3-20.8), respectively.

14.3 CML in Pediatric Patients

The efficacy of SPRYCEL in pediatric patients was evaluated in two pediatric studies of 97 patients with chronic phase CML. Among 97 patients with chronic phase CML treated in two pediatric studies, an open-label, non-randomized dose-ranging trial (NCT00306202) and an open-label, non-randomized, single-arm trial (NCT00777036), 51 patients (exclusively from the single-arm trial) had newly diagnosed chronic phase CML and 46 patients (17 from the dose-ranging trial and 29 from the single-arm trial) were resistant or intolerant to previous treatment with imatinib. Ninety-one of the 97 pediatric patients were treated with SPRYCEL tablets 60 mg/m² once daily (maximum dose of 100 mg once daily for patients with high BSA). Patients were treated until disease progression or unacceptable toxicity.

Baseline demographic characteristics of the 46 imatinib resistant or intolerant patients were: median age 13.5 years (range 2 to 20 years), 78.3% White, 15.2% Asian, 4.4% Black, 2.2% other, and 52% female. Baseline characteristics of the 51 newly diagnosed patients were: median age 12.8 years (range 1.9 to 17.8 years), 60.8% White, 31.4% Asian, 5.9% Black, 2% Other, and 49% female.

Median duration of follow-up was 5.2 years (range 0.5 to 9.3 years) for the imatinib resistant or intolerant patients and 4.5 years (range 1.3 to 6.4 years) for the newly diagnosed patients, respectively. Efficacy results for the two pediatric studies are summarized in Table 20.

Table 20 shows increasing trend for response for CCyR, MCyR, and MMR across time (3 months to 24 months). The increasing trend in response for all three endpoints is seen in both the newly diagnosed and imatinib resistant or intolerant patients.

Table 20: Efficacy of SPRYCEL in Pediatric Patients with CP-CML Cumulative Response Over Time by Minimum Follow-Up Period

	3 months	6 months	12 months	24 months
CCyR				
(95% CI)				
Newly diagnosed (N = 51) ^a	43.1% (29.3, 57.8)	66.7% (52.1, 79.2)	96.1% (86.5, 99.5)	96.1% (86.5, 99.5)
Prior imatinib (N = 46) ^b	45.7% (30.9, 61.0)	71.7% (56.5, 84.0)	78.3% (63.6, 89.1)	82.6% (68.6, 92.2)
MCyR				
(95% CI)				
Newly diagnosed (N = 51) ^a	60.8% (46.1, 74.2)	90.2% (78.6, 96.7)	98.0% (89.6, 100)	98.0% (89.6, 100)
Prior imatinib (N = 46) ^b	60.9% (45.4, 74.9)	82.6% (68.6, 92.2)	89.1% (76.4, 96.4)	89.1% (76.4, 96.4)
MMR				
(95% CI)				
Newly diagnosed (N = 51) ^a	7.8% (2.2, 18.9)	31.4% (19.1, 45.9)	56.9% (42.2, 70.7)	74.5% (60.4, 85.7)
Prior imatinib (N = 46) ^b	15.2% (6.3, 28.9)	26.1% (14.3, 41.1)	39.1% (25.1, 54.6)	52.2% (36.9, 67.1)

^a Patients from pediatric study of newly diagnosed CP-CML receiving oral tablet formulation

^b Patients from pediatric studies of imatinib-resistant or -intolerant CP-CML receiving oral tablet formulation

With a median follow-up of 4.5 years in newly diagnosed patients, the median durations of CCyR, MCyR, MMR could not be estimated as more than half of the responding patients had not progressed at the time of data cut-off. Range of duration of response was (2.5+ to 66.5+ months for CCyR), (1.4 to 66.5+ months for MCyR), and (5.4+ to 72.5+ months for subjects who achieved MMR by month 24 and 0.03+ to 72.5+ months for subjects who achieved MMR at any time), where ‘+’ indicates a censored observation.

With a median follow-up of 5.2 years in imatinib-resistant or -intolerant patients, the median durations of CCyR, MCyR, and MMR could not be estimated as more than half the responding patients had not progressed at the time of data cut-off. Range of duration of response was (2.4 to

86.9+ months for CCyR), (2.4 to 86.9+ months for MCyR), and (2.6+ to 73.6+ months for MMR), where ‘+’ indicates a censored observation.

The median time to response for MCyR was 2.9 months (95% CI: 2.8 months, 3.5 months) in the pooled imatinib-resistant/intolerant CP-CML patients. The median time to response for CCyR was 3.3 months (95% CI: 2.8 months, 4.7 months) in the pooled imatinib-resistant/intolerant CP-CML patients. The median time to response for MMR was 8.3 months (95% CI: 5.0 months, 11.8 months) in the pooled imatinib-resistant/intolerant CP-CML patients.

The median time to response for MCyR was 3.0 months (95% CI: 2.8 months, 4.3 months) in the newly diagnosed treatment-naïve CP-CML patients. The median time to response for CCyR was 5.5 months (95% CI: 3.0 months, 5.7 months) in the newly diagnosed treatment-naïve CP-CML patients. The median time to response for MMR was 8.9 months (95% CI: 6.2 months, 11.7 months) in the newly diagnosed treatment-naïve CP-CML patients.

In the Phase II pediatric study, 1 newly diagnosed patient and 2 imatinib-resistant or -intolerant patients progressed to blast phase CML.

14.4 Ph+ ALL in Pediatric Patients

The efficacy of SPRYCEL in combination with chemotherapy was evaluated in a single cohort (cohort 1) of Study CA180372 (NCT01460160), a multicenter, multiple-cohort study of pediatric patients with newly diagnosed B-cell precursor Ph+ ALL. The 78 patients in cohort 1 received SPRYCEL at a daily dose of 60 mg/m² for up to 24 months, in combination with chemotherapy. The backbone chemotherapy regimen was the AIEOP-BFM ALL 2000 multi-agent chemotherapy protocol.

Patients had a median age of 10.4 years (range 2.6 to 17.9 years) and included 20 patients (25%) 2 to 6 years of age, 37 patients (46%) 7 to 12 years of age, and 24 patients (30%) 13 to 17 years of age. Eighty-two percent of patients were white, and 55% were male. Thirty-two patients (41%) had a white blood cell count (WBC) of $\geq 50,000$ mcl at diagnosis, and 17 patients (22%) had extramedullary disease.

Efficacy was established on the basis of 3-year event-free survival (EFS), defined as the time from the start of SPRYCEL to lack of complete response at the end of the third high risk block, relapse, secondary malignancy, or death from any cause. The 3-year EFS binary rate for patients on Study CA180372 was 64.1% (95% CI: 52.4, 74.7). At the end of induction, 75 patients (96%) had a bone marrow with $< 5\%$ lymphoblasts, and 76 patients (97%) achieved this by the end of consolidation.

15 REFERENCES

1. <http://www.osha.gov/SLTC/hazardousdrugs/index.html>

16 HOW SUPPLIED/STORAGE AND HANDLING

16.1 How Supplied

SPRYCEL[®] (dasatinib) tablets are available as described in Table 21.

Table 21: SPRYCEL Trade Presentations

NDC Number	Strength	Description	Tablets per Bottle
0003-0527-11	20 mg	white to off-white, biconvex, round, film-coated tablet with “BMS” debossed on one side and “527” on the other side	60
0003-0528-11	50 mg	white to off-white, biconvex, oval, film-coated tablet with “BMS” debossed on one side and “528” on the other side	60
0003-0524-11	70 mg	white to off-white, biconvex, round, film-coated tablet with “BMS” debossed on one side and “524” on the other side	60
0003-0855-22	80 mg	white to off-white, biconvex, triangle, film-coated tablet with “BMS” and “80” (BMS over 80) debossed on one side and “855” on the other side	30
0003-0852-22	100 mg	white to off-white, biconvex, oval, film-coated tablet with “BMS 100” debossed on one side and “852” on the other side	30
0003-0857-22	140 mg	white to off-white, biconvex, round, film-coated tablet with “BMS” and “140” (BMS over 140) debossed on one side and “857” on the other side	30

16.2 Storage

SPRYCEL tablets should be stored at 20°C to 25°C (68°F to 77°F); excursions permitted between 15°C and 30°C (59°F and 86°F) [see USP Controlled Room Temperature].

16.3 Handling and Disposal

SPRYCEL is an antineoplastic product. Follow special handling and disposal procedures.¹

Personnel who are pregnant should avoid exposure to crushed or broken tablets.

SPRYCEL tablets consist of a core tablet, surrounded by a film coating to prevent exposure of healthcare professionals to the active substance. The use of latex or nitrile gloves for appropriate disposal when handling tablets that are inadvertently crushed or broken is recommended, to minimize the risk of dermal exposure.

17 PATIENT COUNSELING INFORMATION

Advise the patient to read the FDA-approved patient labeling (Patient Information).

Bleeding

Inform patients of the possibility of serious bleeding and to report immediately any signs or symptoms suggestive of hemorrhage (unusual bleeding or easy bruising) [see *Warnings and Precautions (5.2)*].

Myelosuppression

Inform patients of the possibility of developing low blood cell counts. Advise patients to immediately report fever particularly in association with any suggestion of infection [*see Warnings and Precautions (5.1)*].

Fluid Retention

Patients should be informed of the possibility of developing fluid retention (swelling, weight gain, dry cough, chest pain on respiration, or shortness of breath) and advised to seek medical attention promptly if those symptoms arise [*see Warnings and Precautions (5.3)*].

Pulmonary Arterial Hypertension

Inform patients of the possibility of developing pulmonary arterial hypertension (dyspnea, fatigue, hypoxia, and fluid retention) and advise them to seek medical attention promptly if those symptoms arise [*see Warnings and Precautions (5.5)*].

Tumor Lysis Syndrome

Inform patients to immediately report and seek medical attention for any symptoms such as nausea, vomiting, weakness, edema, shortness of breath, muscle cramps, and seizures, which may indicate tumor lysis syndrome [*see Warnings and Precautions (5.8)*].

Growth and Development in Pediatric Patients

Inform pediatric patients and their caregivers of the possibility of developing bone growth abnormalities, bone pain, or gynecomastia and advise them to seek medical attention promptly if those symptoms arise [*see Warnings and Precautions (5.10)*].

Embryo-Fetal Toxicity

- Advise pregnant women of the potential risk to a fetus [*see Warnings and Precautions (5.9) and Use in Specific Populations (8.1)*].
- Advise females of reproductive potential to avoid pregnancy, which may include use of effective contraception during treatment with SPRYCEL and for 30 days after the final dose. Advise females to contact their healthcare provider if they become pregnant, or if pregnancy is suspected, while taking SPRYCEL [*see Warnings and Precautions (5.9) and Use in Specific Populations (8.1, 8.3)*].

Lactation

- Advise women that breastfeeding is not recommended during treatment with SPRYCEL and for 2 weeks after the final dose [*see Use in Specific Populations (8.2)*].

Gastrointestinal Complaints

Inform patients that they may experience nausea, vomiting, or diarrhea with SPRYCEL. Advise patients to seek medical attention if these symptoms are bothersome or persistent.

Advise patients using antacids to avoid taking SPRYCEL and antacids less than 2 hours apart [*see Drug Interactions (7.1)*].

Pain

Inform patients that they may experience headache or musculoskeletal pain with SPRYCEL. Advise patients to seek medical attention if these symptoms are bothersome or persistent.

Fatigue

Inform patients that they may experience fatigue with SPRYCEL. Advise patients to seek medical attention if this symptom is bothersome or persistent.

Rash

Inform patients that they may experience skin rash with SPRYCEL. Advise patients to seek medical attention if this symptom is bothersome or persistent.

Lactose

Inform patients that SPRYCEL contains 135 mg of lactose monohydrate in a 100-mg daily dose and 189 mg of lactose monohydrate in a 140-mg daily dose.

Missed Dose

Advise patients that if they miss a dose of SPRYCEL, they should take the next scheduled dose at its regular time. The patient should not take two doses at the same time.

Distributed by:
Bristol-Myers Squibb Company
Princeton, NJ 08543 USA

PATIENT INFORMATION
SPRYCEL® (Spry-sell)
(dasatinib)
tablets

What is SPRYCEL?

SPRYCEL is a prescription medicine used to treat:

- adults with newly diagnosed Philadelphia chromosome-positive (Ph+) chronic myeloid leukemia (CML) in chronic phase.
- adults with Ph+ CML who no longer benefit from, or did not tolerate, other treatment, including Gleevec® (imatinib mesylate).
- adults with Ph+ acute lymphoblastic leukemia (Ph+ ALL) who no longer benefit from, or did not tolerate, other treatment.
- children 1 year of age and older with Ph+ CML in chronic phase.
- children 1 year of age and older with newly diagnosed Ph+ ALL in combination with chemotherapy.

Before taking SPRYCEL, tell your healthcare provider about all of your medical conditions, including if you:

- have problems with your immune system
- have heart problems, including a condition called congenital long QT syndrome
- have low potassium or low magnesium levels in your blood
- are lactose (milk sugar) intolerant
- are pregnant or plan to become pregnant. SPRYCEL can harm your unborn baby. You should not become pregnant during treatment with SPRYCEL. If you are able to become pregnant, you should use effective birth control during treatment and for 30 days after your final dose of SPRYCEL. Talk to your healthcare provider right away if you become pregnant or think you may be pregnant during treatment with SPRYCEL.
- are breastfeeding or plan to breastfeed. It is not known if SPRYCEL passes into your breast milk. You should not breastfeed during treatment and for 2 weeks after your final dose of SPRYCEL.

Tell your healthcare provider about all the medicines you take, including prescription and over-the-counter medicines, vitamins, antacids, and herbal supplements. **If you take an antacid medicine, take it 2 hours before or 2 hours after your dose of SPRYCEL.**

How should I take SPRYCEL?

- Take SPRYCEL exactly as your healthcare provider tells you to take it.
- Your healthcare provider may change your dose of SPRYCEL or temporarily stop treatment with SPRYCEL. **Do not change your dose or stop taking SPRYCEL without first talking to your healthcare provider.**
- Take SPRYCEL 1 time a day.
- Take SPRYCEL with or without food, either in the morning or in the evening.
- Swallow SPRYCEL tablets whole. Do not crush, cut or chew the tablets.
 - If your child cannot swallow tablets whole, talk with your healthcare provider.
- You should not drink grapefruit juice during treatment with SPRYCEL.
- If you miss a dose of SPRYCEL, take your next scheduled dose at your regular time. Do not take two doses at the same time.
- If you take too much SPRYCEL, call your healthcare provider or go to the nearest hospital emergency room right away.

What are the possible side effects of SPRYCEL?

SPRYCEL may cause serious side effects, including:

- **Low blood cell counts.** Low blood cell counts are common with SPRYCEL and can be severe, including low red blood cell counts (anemia), low white blood cell counts (neutropenia), and low platelet counts (thrombocytopenia). Your healthcare provider will do blood tests to check your blood cell counts regularly during your treatment with SPRYCEL. Call your healthcare provider right away if you have a fever or any signs of an infection during treatment with SPRYCEL.
- **Bleeding problems.** Bleeding problems are common with SPRYCEL. Sometimes these bleeding problems can be serious and lead to death. Call your healthcare provider right away if you have:
 - unusual bleeding or bruising of your skin
 - bright red or dark tar-like stools
 - decreased alertness, headache, or change in speech
- **Your body may hold too much fluid (fluid retention).** Fluid retention is common with SPRYCEL and can sometimes be severe. In severe cases, fluid may build up in the lining of your lungs, the sac around your heart, or

your stomach cavity. Call your healthcare provider right away if you get any of these symptoms during treatment with SPRYCEL:

- swelling all over your body
- weight gain
- shortness of breath, especially if this happens with low levels of physical activity or at rest
- dry cough
- chest pain when taking a deep breath
- **Heart problems.** SPRYCEL may cause an abnormal heart rate, heart problems, or a heart attack. Your healthcare provider will monitor the potassium and magnesium levels in your blood, and your heart function.
- **Pulmonary Arterial Hypertension (PAH).** SPRYCEL may cause high blood pressure in the vessels of your lungs. PAH may happen at any time during your treatment with SPRYCEL. Your healthcare provider should check your heart and lungs before and during treatment with SPRYCEL. Call your healthcare provider right away if you have shortness of breath, tiredness, or swelling all over your body (fluid retention).
- **Severe skin reactions.** SPRYCEL may cause skin reactions that can sometimes be severe. Get medical help right away if you get a skin reaction with fever, sore mouth or throat, or blistering or peeling of your skin or in the mouth.
- **Tumor Lysis Syndrome (TLS).** TLS is caused by a fast breakdown of cancer cells. TLS can cause you to have kidney failure and the need for dialysis treatment, and an abnormal heartbeat. Your healthcare provider may do blood tests to check you for TLS. Call your healthcare provider or get emergency medical help right away if you develop any of these symptoms during treatment with SPRYCEL:
 - nausea
 - vomiting
 - weakness
 - swelling
 - shortness of breath
 - muscle cramps
 - seizures
- **Slowing of growth and development in children.** Effects on bone growth and development in children have happened with SPRYCEL and can sometimes be severe. Your healthcare provider will monitor your child's bone growth and development during treatment with SPRYCEL. Get medical help right away if your child develops bone pain.

The most common side effects of SPRYCEL in adults and children receiving SPRYCEL alone include:

- diarrhea
- headache
- skin rash
- shortness of breath
- tiredness
- nausea
- muscle pain

The most common side effects of SPRYCEL in children receiving SPRYCEL with chemotherapy include:

- swelling, pain and redness of the lining of your mouth, throat, stomach and bowel (mucositis)
- low white blood cell counts with fever
- fever
- diarrhea
- nausea
- vomiting
- muscle pain
- stomach (abdominal) pain
- cough
- headache
- rash
- tiredness
- constipation
- abnormal heart rate
- high blood pressure (hypertension)
- swelling
- infections
- low blood pressure
- decreased appetite
- allergic reactions
- shortness of breath
- nose bleed
- numbness or tingling of your hands and feet
- feeling confused or disoriented

SPRYCEL may cause fertility problems in males and females. Talk to your healthcare provider if this is a concern for you.

Tell your healthcare provider if you have any side effect that bothers you or that does not go away. These are not all of the possible side effects of SPRYCEL.

Call your doctor for medical advice about side effects. You may report side effects to FDA at 1-800-FDA-1088.

How should I store SPRYCEL?

- Store SPRYCEL at room temperature between 68°F to 77°F (20°C to 25°C).
- Ask your healthcare provider or pharmacist about the right way to throw away expired or unused SPRYCEL.
- Wear latex or nitrile gloves when handling tablets that have accidentally been crushed or broken.
- Females who are pregnant should not handle crushed or broken SPRYCEL tablets.

Keep SPRYCEL and all medicines out of the reach of children.**General information about the safe and effective use of SPRYCEL.**

Medicines are sometimes prescribed for purposes other than those listed in a Patient Information leaflet. Do not use SPRYCEL for a condition for which it is not prescribed. Do not give SPRYCEL to other people even if they have the same symptoms you have. It may harm them. You can ask your healthcare provider or pharmacist for information about SPRYCEL that is written for health professionals.

What are the ingredients in SPRYCEL?

Active ingredient: dasatinib

Inactive ingredients: lactose monohydrate, microcrystalline cellulose, croscarmellose sodium, hydroxypropyl cellulose, and magnesium stearate. The tablet coating consists of hypromellose, titanium dioxide, and polyethylene glycol.

Distributed by: Bristol-Myers Squibb Company, Princeton, NJ 08543 USA
For more information, go to www.sprycel.com or call 1-800-332-2056.

This Patient Information has been approved by the U.S. Food and Drug Administration.

Revised: December 2018

PRODUCT MONOGRAPH

PrTASIGNA[®]

(Nilotinib Capsules)

50 mg, 150 mg and 200 mg nilotinib (as nilotinib hydrochloride monohydrate)

Protein kinase inhibitor

Novartis Pharmaceuticals Canada Inc.
385, Bouchard Blvd.
Dorval, Quebec, H9S 1A9

Date of Preparation:
December 4, 2006

Control No: 228181

Date of Revision:
March 13, 2020

PrTASIGNA[®] (nilotinib capsules) is a registered trademark

Table of Contents

PART I: HEALTH PROFESSIONAL INFORMATION.....	3
INDICATIONS AND CLINICAL USE.....	3
CONTRAINDICATIONS	4
WARNINGS AND PRECAUTIONS.....	5
ADVERSE REACTIONS.....	145
DRUG INTERACTIONS	23
DOSAGE AND ADMINISTRATION	32
OVERDOSAGE	41
ACTION AND CLINICAL PHARMACOLOGY	41
STORAGE AND STABILITY.....	44
SPECIAL HANDLING INSTRUCTIONS	44
DOSAGE FORMS, COMPOSITION AND PACKAGING	45
PART II: SCIENTIFIC INFORMATION	46
PHARMACEUTICAL INFORMATION.....	47
CLINICAL TRIALS.....	49
DETAILED PHARMACOLOGY	70
TOXICOLOGY	72
REFERENCES	77
PART III: CONSUMER INFORMATION.....	81

PrTASIGNA®

(nilotinib capsules)

PART I: HEALTH PROFESSIONAL INFORMATION

SUMMARY PRODUCT INFORMATION

Route of Administration	Pharmaceutical Form/Strength	Clinically Relevant Nonmedicinal Ingredients
Oral	Capsule 200 mg Capsule 150 mg Capsule 50 mg	Capsule content: Lactose monohydrate. <i>For a complete listing see Dosage Forms, composition and Packaging section.</i>

INDICATIONS AND CLINICAL USE

TASIGNA (nilotinib capsules) is indicated for:

- the treatment of adult patients with newly diagnosed Philadelphia chromosome positive chronic myeloid leukemia (Ph+ CML) in chronic phase (CP).

Clinical effectiveness of TASIGNA in adults with newly diagnosed Ph+ CML-CP is based on major molecular response rate at 12 months and complete cytogenetic response rate by 12 months.

- the treatment of pediatric patients 2 years of age and older with newly diagnosed Ph+ CML-CP.

Clinical effectiveness of TASIGNA in pediatric patients with newly diagnosed Ph+ CML-CP is based on major molecular response by 12 cycles and complete cytogenetic response at 12 cycles.

- the treatment of chronic phase (CP) and accelerated phase (AP) Philadelphia chromosome positive chronic myeloid leukemia (Ph+CML) in adult patients resistant to or intolerant of at least one prior therapy including imatinib.

Clinical effectiveness of TASIGNA in adults with imatinib-resistant or -intolerant Ph+ CML-CP was based on the unconfirmed major cytogenetic and complete hematologic response rates

Clinical effectiveness of TASIGNA in imatinib-resistant or -intolerant Ph+ CML-AP for adult patients was based on the confirmed hematologic response rates and the unconfirmed major cytogenetic response rates.

- the treatment of pediatric patients 2 years of age and older with Ph+ CML-CP with resistance or intolerance to prior therapy including imatinib.

Clinical effectiveness of TASIGNA in pediatric patients with imatinib-resistant or -intolerant Ph+ CML-CP was based on the MMR rate at 6 cycles.

No overall survival benefit has been demonstrated.

Pediatrics: The safety and efficacy of TASIGNA in pediatric patients with Ph+ CML-CP from 2 to less than 18 years of age have been established. There is no experience in pediatric patients below 2 years of age or in pediatric patients with Ph+ CML-AP or blast crisis (BC). The long-term effects of prolonged treatment with TASIGNA in pediatric patients are unknown (see **WARNINGS AND PRECAUTIONS**).

Geriatrics (≥ 65 years of age) : Approximately 12% and 30% of subjects in the clinical studies (Phase III study (A2303) in newly diagnosed Ph+ CML-CP; and Phase II study (A2101) in resistant or -intolerant Ph+ CML-CP and CML-AP) were 65 years of age or older respectively. No major differences were observed for safety and efficacy in patients ≥ 65 years of age as compared to adults 18 to 65 years of age.

CONTRAINDICATIONS

Do not use in patients with a known long QTc prolongation or with a persistent QTc of >480 msec (See **WARNINGS AND PRECAUTIONS**).

Do not use in patients with uncorrectable hypokalemia or hypomagnesemia.

Do not use in patients with known hypersensitivity to nilotinib or to any of the excipients (for a complete listing, see the Dosage Forms, Composition and Packaging section of the product monograph).

WARNINGS AND PRECAUTIONS

Serious Warnings and Precautions

- Sudden Cardiac Deaths (see Warnings and Precautions and Adverse Reactions)
- QT interval prolongation (see Warnings and Precautions, Drug Interactions, Food Effect and Monitoring and Laboratory Tests)
- Do not use in patients with uncorrectable hypokalemia or hypomagnesemia (see Warnings and Precautions)
- Ischemic heart disease, ischemic cerebrovascular events and peripheral arterial occlusive disease (PAOD), (in some rare cases, fatal) (see Warnings and Precautions and Monitoring and Laboratory Tests)
- Hepatotoxicity/ Hepatic failure (in some cases, fatal) (see Warnings and Precautions)
- Pancreatitis (see Warnings and Precautions)
- Myelosuppression (thrombocytopenia, neutropenia and anemia) (see Warnings and Precautions)

TASIGNA should only be prescribed by a qualified healthcare professional who is experienced in the use of antineoplastic therapy and in the treatment of chronic myeloid leukemia.

Treatment discontinuation in Ph⁺ CML-CP patients who have achieved a sustained molecular response (MR4.5) should be attempted only if the monitoring requirements using a quantitative diagnostic test validated with a sensitivity of at least MR4.5 ($BCR-ABL/ABL \leq 0.0032\%$ IS) can be performed at the specified frequency (see Warnings and Precautions; Monitoring and Laboratory Tests). Discontinuation of TASIGNA therapy should be initiated by a physician experienced in the treatment of patients with CML.

Discontinuation of TASIGNA treatment to attempt treatment-free remission (TFR) phase in pediatric patients has not been assessed.

General

BCR-ABL Mutations : The T315I mutation confers a high level of resistance to nilotinib and most tyrosine kinase inhibitors based on *in vitro* and clinical data.

Carcinogenesis and Mutagenesis

In the 2-year rat carcinogenicity study conducted orally at TASIGNA at 5, 15, and 40 mg/kg/day, there was a non-statistically significant increased incidence of uterine hemangiosarcoma, adenocarcinoma and squamous cell carcinoma and an increase in follicular cell adenoma in the thyroid gland (barely reaching statistical significance). Given that the incidence of thyroid follicular cell adenoma and uterine adenocarcinoma were within the historical control range, the data do not clearly indicate that TASIGNA is carcinogenic in rats. Exposures (in terms of AUC) at the highest dose level represented approximately 2x to 3x human daily steady state exposure at the dose of 800 mg/day. TASIGNA is not mutagenic (see **TOXICOLOGY**).

In the 26-week Tg.rasH2 mouse carcinogenicity study, in which nilotinib was administered at 30, 100 and 300 mg/kg/day, skin papillomas/carcinomas were detected at 300 mg/kg, representing approximately 30 to 40 times (based on AUC) the human exposure at the maximum approved dose of 800 mg/day (administered as 400 mg twice daily). The No-Observed-Effect-Level for the skin neoplastic lesions was 100 mg/kg/day, representing approximately 10 to 20 times the human exposure at the maximum approved dose of 800 mg/day (administered as 400 mg twice daily).

The relevance of the findings from the rat and mouse carcinogenicity studies for humans is not known at this time.

Cardiovascular

Sudden Cardiac Deaths : In clinical trials, 19 cases of sudden cardiac death have been reported out of 11,351 patients receiving TASIGNA (uncommon frequency of 0.17%). Of the 19 cases, 13 documented cases had a past medical history of cardiac disease or significant cardiac risk factors for sudden cardiac death. In 4 of the 19 cases of sudden cardiac death, patients had no prior medical history of cardiac disease. Comorbidities in addition to the underlying malignancy were also frequently present as were concomitant medications. Ventricular repolarization abnormalities may have been contributory factors. No cases of sudden cardiac deaths have been reported in any treatment group in the newly diagnosed Ph+ CML-CP Phase III study (A2303). Based on post-marketing exposure in patient-years, the estimated reporting rate for spontaneous reports of sudden death is 0.02% per patient-year.

QT Prolongation : *In vitro* data indicate that nilotinib has the potential to prolong cardiac ventricular repolarization (QT interval).

In the Phase III study (A2303) in newly diagnosed Ph+ CML-CP patients, the maximum QTcF mean increase from baseline was 12.3 msec in the nilotinib 300 mg twice daily arm (two-sided 90% Upper CI: 14.4) and 12.9 msec in the nilotinib 400 mg twice daily arm (two-sided 90% Upper CI: 15.1). At the recommended dose of 300 mg twice daily no patient had an absolute QTcF of >480 msec and no events of Torsades de Pointes were observed in this trial. One patient in the 400 mg twice daily arm had an absolute QTcF of >480 msec. Thirty-two (32) patients (11.5%) in nilotinib 300 mg twice daily treatment group and 40 patients (14.4%) in nilotinib 400 mg twice daily treatment group had absolute QTcF >450 msec. QTcF increase from baseline that exceeded 60 msec was observed in 5 patients while on treatment drug (one in the TASIGNA 300 mg twice daily treatment group and four in the TASIGNA 400 mg twice daily treatment group).

In the Phase II study (A2101) in imatinib-resistant or -intolerant CML patients in CP and AP, treated with nilotinib 400 mg twice daily, the change from baseline in mean time-averaged QTcF interval at steady-state was 5 msec and 8 msec, respectively. The maximum QTcF mean increase from baseline was 6.8 msec (two-sided 90% Upper CI: 8.4) and 13.4 msec (two-sided 90% Upper CI: 17.2) respectively. QTcF of >500 msec was observed in 4 (1.2%) of CML-CP patients. QTcF > 60 msec increase from baseline was observed in the combined CML-CP and -AP patient populations (CML-CP 8 (2.5%) and CML-AP 11 (8%).

In a healthy volunteer study (A2119), peak plasma concentrations were 26% lower than in the clinical study in CML patients. The maximum mean placebo-adjusted QTcF increase from baseline was 18 msec (1 –sided 95% Upper CI: 26 msec). In addition, no clinically relevant arrhythmias were observed during the conduct of the trial. In particular, no episodes of Torsades de Pointes (either transient or sustained) were observed.

Clinically meaningful prolongation of the QT interval may occur when TASIGNA is inappropriately taken with food, and/or strong CYP3A4 inhibitors and/or medicinal products with a known potential to prolong QT; therefore, concomitant administration should be avoided (see **Drug-Food Interactions** and **Drug-Drug Interactions**).

The presence of hypokalemia and hypomagnesemia may place patients at risk of developing QT prolongation (see **CONTRAINDICATIONS**).

TASIGNA should be avoided in patients who are at significant risk of developing prolongation of QTc interval, such as: patients taking anti-arrhythmic medicines or other drugs that may lead to QT prolongation, and cumulative high-dose anthracycline therapy. Hypokalemia or hypomagnesemia must be corrected prior to TASIGNA administration (See **Drug-Drug Interactions** and **DOSAGE AND ADMINISTRATION**).

TASIGNA should be used with caution in patients with uncontrolled or significant cardiac disease including recent myocardial infarction, congestive heart failure (CHF), unstable angina or clinically significant bradycardia.

Other Cardiovascular Disorders : In clinical studies, newly diagnosed Ph+ CML-CP and imatinib-resistant or -intolerant Ph+ CML-CP and CML-AP patients with any of the following uncontrolled or significant cardiac disease were excluded: recent myocardial infarction, CHF, unstable angina, or clinically significant bradycardia. Imatinib-resistant or -intolerant Ph+ CML-CP and CML-AP patients with complete left bundle branch block and/or right bundle branch block, with left anterior hemiblock, or with bifascicular block were excluded from the study. Newly diagnosed Ph+ CML-CP patients with complete left bundle branch block were also excluded. ECG and cardiac enzyme monitoring were conducted in patients throughout the studies.

In newly diagnosed Ph+ CML-CP, left ventricular ejection fraction (LVEF) was assessed by echocardiography at baseline (within 14 days prior to the initial dose of nilotinib) in all patients. LVEF assessment was repeated in these patients on a regular basis and as clinically indicated thereafter. No patients in any treatment groups had a LVEF <45% during treatment. Also, there were no patients with 15% or greater decrease from baseline in LVEF.

In imatinib-resistant or -intolerant Ph+ CML-CP and CML-AP patients, LVEF was assessed by echocardiography or MUGA scan at baseline (within 14 days prior to the initial dose of nilotinib) in 49/438 patients. LVEF assessment was repeated in these patients as clinically indicated thereafter, and at the time of study completion. There was no clinically significant change in LVEF from baseline in the assessed patients.

Cardiovascular adverse reactions have been observed in patients in the TASIGNA clinical studies at the recommended doses including cardiac failure observed in <1% of patients with imatinib-resistant or -intolerant Ph+ CML-CP and CML-AP, and with newly diagnosed Ph+ CML-CP. In a Phase III study (A2303) in newly diagnosed Ph+ CML patients, with a median time on therapy of 60.5 months in the clinical trial, cases of cardiovascular events included ischemic heart disease-related events (5.0% and 9.4% in the nilotinib 300 mg and 400 mg twice daily groups respectively, and 2.5% in the imatinib arm), peripheral arterial occlusive disease (3.6% and 2.9% in the nilotinib 300 mg and 400 mg twice daily groups respectively, and 0% in the imatinib arm), and ischemic cerebrovascular events (1.4% and 3.2% in the nilotinib 300 mg and 400 mg twice daily groups respectively, and 0.7% in the imatinib arm).

Peripheral arterial occlusive disease, ischemic heart disease and ischemic cerebrovascular events include events such as femoral artery stenosis, coronary artery stenosis, cerebrovascular accident, vascular graft occlusion, arterial stenosis limb and carotid artery stenosis. Peripheral arterial occlusive disease can be severe, rapidly evolving and may affect more than one site. Peripheral arterial occlusive disease might require repeated revascularization procedures and can result in complications that may be serious such as limb necrosis and amputations. Most of the patients who developed cardiovascular adverse reactions had pre-existing documented cardiovascular disease or risk factors for atherosclerotic-related disease.

Of the 365 patients treated with TASIGNA, who had no documented pre-existing risk factors for cardiovascular disease, 19 patients (5%) experienced atherosclerotic-related events. Since it is not known whether TASIGNA caused or exacerbated these conditions, patients should be monitored during treatment with TASIGNA for signs of atherosclerotic-related conditions and actively managed during TASIGNA therapy according to standard guidelines. If acute signs or symptoms of cardiovascular events occur, advise patients to seek immediate medical attention. Administer with caution in patients with pre-existing risk factors for atherosclerosis (See **Monitoring and Laboratory Tests, DOSAGE AND ADMINISTRATION/Dose Adjustments or Modifications, ADVERSE REACTIONS** and **Post-Market Adverse Reactions**).

Endocrine and Metabolism

Diabetes/hyperglycemia: New-onset diabetes/hyperglycemia were reported with a common frequency (4.8%) in CML patients in completed clinical trials. In addition, cases of exacerbated diabetes have been reported from post-marketing experience (see **ADVERSE REACTIONS**).

Fluid retention: Medically severe forms of drug-related fluid retention such as Grade 3 or 4 pleural effusion, pulmonary edema, and pericardial effusion were reported with an uncommon frequency (0.1 to 1%) observed in a Phase III study of newly diagnosed Ph+ CML-CP patients. Similar events were observed in post-marketing reports. Unexpected, rapid weight gain should be carefully investigated. If signs or symptoms of severe fluid retention appear during treatment with TASIGNA, the etiology should be evaluated and patients treated accordingly (see **Monitoring and Laboratory Tests, DOSAGE AND ADMINISTRATION/ Dose Adjustments or Modifications**).

Hematologic

Myelosuppression: Treatment with TASIGNA is often associated with thrombocytopenia, neutropenia and anemia (NCI CTC Grade 3/4). The occurrence is more frequent in patients with imatinib-resistant or -intolerant CML and in particular in patients with CML-AP. Complete blood counts should be performed every two weeks for the first 2 months and then monthly thereafter, or as clinically indicated. Myelosuppression was generally reversible and usually managed by withholding TASIGNA temporarily or reducing the dose (see **DOSAGE AND ADMINISTRATION**).

Hemorrhage

Gastrointestinal and CNS hemorrhage were reported in 1% and <1% of imatinib-resistant or -intolerant Ph+ CML-CP and CML-AP patients, respectively. In newly diagnosed Ph+ CML-CP, gastrointestinal hemorrhage, regardless of causality, was reported in 3% in the patients receiving TASIGNA 300 mg twice daily and in 5% in the patients receiving TASIGNA 400 mg twice daily. CNS hemorrhage, regardless of causality, was reported in <1% of the newly diagnosed Ph+ CML-CP patients receiving TASIGNA 300 mg and in patients receiving TASIGNA 400 mg twice daily (See **ADVERSE REACTIONS**).

Hepatic/Biliary and Pancreatic

Hepatotoxicity/Hyperbilirubinemia: TASIGNA may result in elevation of bilirubin due to competitive inhibition of Uridine-Diphosphate-Glucuronyl Transferase (UGT1A1) and in elevation of AST, ALT and alkaline phosphatase (see **Drug-Drug Interactions** and **ADVERSE REACTIONS**). Patients taking TASIGNA who may be predisposed to or who may have Gilbert's syndrome may have a higher risk of unconjugated hyperbilirubinemia. This may also occur in patients who are taking drugs known to inhibit UGT1A1.

Pediatric population: Laboratory abnormalities of mild to moderate transient elevations of aminotransferases and total bilirubin have been observed in children at a higher frequency than in adults, indicating a higher risk of hepatotoxicity in the pediatric population (see **ADVERSE REACTIONS, Safety of TASIGNA in Pediatric Patients with Newly Diagnosed or Resistant/Intolerant Ph+ CML-CP**). If clinically significant hepatotoxicity develops, consider dose modifications (see **DOSAGE AND ADMINISTRATION**).

Hepatic Failure: Twenty five cases of hepatic failure were reported in CML patients. Five of these were fatal including one case with no previous hepatic impairment. There were 29 cases of ascites reported in pooled clinical trials data which included all adverse events regardless of causality and the patient population. Three cases of hepatic steatosis and 2 cases of hepatic necrosis were reported in all clinical trial patients. One of those fatal cases which satisfied Hy's Law was hepato-renal syndrome and fulminant hepatitis reported in a 23 year old male CML patient who had received 4 months of treatment with TASIGNA. Two cases of cytolytic hepatitis were reported in newly diagnosed Ph+ CML-CP patients. If clinically significant hepatotoxicity develops, consider dose modifications (see **DOSAGE AND ADMINISTRATION**).

Elevated Serum Lipase/Amylase: Grade 3/4 elevation in serum lipase and amylase have been observed. Few of these elevations were associated with abdominal pain or pancreatitis. There

were 5 cases (1.1%) of pancreatitis reported in imatinib-resistant or -intolerant Ph+ CML-CP and CML-AP patients (N= 458). In newly diagnosed Ph+ CML-CP, 5 (1.8%) and 8 (2.9%) cases of pancreatitis were reported in patients receiving TASIGNA 300 mg twice daily (N=279), and 400 mg twice daily (N=277) respectively. Caution is recommended in patients with previous history of pancreatitis. In case lipase elevations are accompanied by abdominal symptoms, doses should be interrupted and appropriate diagnostics should be considered in order to rule out pancreatitis (see **DOSAGE AND ADMINISTRATION**).

Immune

Six cases of vasculitis (including 1 cerebral) have been reported in pooled clinical trials data which included all adverse events regardless of causality and the patient population (see **ADVERSE REACTIONS**).

Hepatitis B virus reactivation: Reactivation of hepatitis B virus (HBV) has occurred in patients who are chronic carriers of this virus after receiving a BCR-ABL tyrosine kinase inhibitor (TKI), including TASIGNA. Some cases resulted in acute hepatic failure or fulminant hepatitis leading to liver transplantation or death.

Patients should be tested for HBV infection before initiating treatment with TASIGNA. Patients currently on TASIGNA should have baseline testing for HBV infection in order to identify chronic carriers of the virus. Experts in liver disease and in the treatment of hepatitis B should be consulted before treatment is initiated in patients with positive HBV serology (including those with active disease) and for patients who test positive for HBV infection during treatment. Carriers of HBV who require treatment with TASIGNA should be closely monitored for signs and symptoms of active HBV infection throughout therapy and for several months following termination of therapy.

Musculoskeletal

Several cases of possible rhabdomyolysis, and some with concomitant elevations in serum creatinine, creatine kinase, creatine phosphokinase and hepatic transaminases, have been reported (unknown frequency). Several of these cases had pre-existing risk factors and/or were receiving concomitant medications known to be associated with this adverse event (see **ADVERSE REACTIONS**).

Peri-Operative Considerations

Total gastrectomy: The bioavailability of nilotinib was shown to be reduced in patients administered 400 mg bid TASIGNA with total gastrectomy versus non-gastrectomized patients (see **Pharmacokinetics** section). More frequent follow-up of adult and pediatric patients should be considered.

Renal

Acute renal failure (including a fatality) has been reported in 4 CML patients (uncommon frequency).

Respiratory

Four cases of interstitial lung disease (Grade 3/4) have been reported (uncommon frequency) in CML patients.

Sensitivity/Intolerance

Since the capsules contain lactose, TASIGNA is not recommended for patients with rare hereditary problems of galactose intolerance, severe lactase deficiency or of glucose-galactose malabsorption.

Sexual Function/Reproduction

Fertility: The effect of TASIGNA on male and female fertility in humans is not known. Increased post-implantation loss was observed in both the fertility study, with the treatment of both female and male rats, and in the embryotoxicity study with the treatment of female rabbits (see **TOXICOLOGY, Reproductive toxicity studies**). Sexually active male or female patients taking TASIGNA should use highly effective contraception. Prior to initiating TASIGNA therapy, physicians should advise and counsel their patients as appropriate (see **WARNINGS AND PRECAUTIONS, Females of childbearing potential and Male patients**).

Tumour Lysis Syndrome

Cases of tumor lysis syndrome have been reported in patients treated with TASIGNA in pooled clinical trials. For monitoring recommendations see **DOSAGE AND ADMINISTRATION**.

Special Populations

Renal Impairment

Clinical studies have not been performed in patients with impaired renal function. Clinical studies have excluded patients with serum creatinine concentration >1.5 times the upper limit of the normal range.

TASIGNA and its metabolites are not renally excreted (See **Pharmacokinetics**).

Due to the potential for tumour lysis syndrome in patients treated with TASIGNA, patients with decreased renal function may be at increased risk (See **MONITORING AND LABORATORY TESTS** and **DOSAGE AND ADMINISTRATION**).

Hepatic impairment

Hepatic impairment has an effect on the pharmacokinetics of TASIGNA. Single dose administration of TASIGNA 200 mg in adults resulted in increases in AUC of 35%, 35% and 56% in subjects with mild, moderate and severe hepatic impairment, respectively compared to a control group of subjects with normal hepatic function. The steady-state C_{max} of TASIGNA will likely to be increased by up to approximately 29% in subjects with hepatic impairment. Clinical studies have excluded patients with ALT and/ or AST >2.5 (or >5, if related to disease) times the upper limit of the normal range and/ or total bilirubin >1.5 times the upper limit of the normal range. Metabolism of nilotinib is mainly hepatic. TASIGNA should be used with caution and

careful clinical monitoring (including close monitoring of the QTc interval) in patients with hepatic impairment (see **DOSAGE AND ADMINISTRATION**).

Gilbert's syndrome : Due to a polymorphism in the enzyme UGT1A1 in patients who may be predisposed to Gilbert's syndrome, or in patients with Gilbert's syndrome, a higher risk unconjugated hyperbilirubinemia with nilotinib can occur, but is clinically benign and potentially persistent. No specific medical intervention is warranted (see **DOSAGE AND ADMINISTRATION**).

Pregnant Women

There are limited data on the use of TASIGNA in pregnant women. TASIGNA should not be used during pregnancy. There have been post-market reports of serious adverse events (spontaneous abortions, premature delivery, fetal abnormalities and/or deaths) from women who have taken TASIGNA during pregnancy (see **ADVERSE REACTIONS, Post Market Adverse Reactions, Pregnancy, Puerperium and Perinatal conditions, and Congenital, Familiar and Genetic Disorders**).

Studies in pregnant rats and rabbits showed maternal and embryo-fetal toxicity and lethality at exposures to nilotinib comparable to the human exposure (see **TOXICOLOGY, Reproductive toxicity studies**). Nilotinib and/or its metabolites showed placenta transfer to the fetus which may account for the incidence of embryo-lethal and embryotoxicity (see **DETAILED PHARMACOLOGY, Animal pharmacokinetics**).

Therefore, pregnant women must be informed of the potential harm to the fetus prior to initiation of TASIGNA therapy. If a patient becomes pregnant while taking TASIGNA, the benefits of therapy versus the potential risks of the fetus should be evaluated by the physician and the treatment options should be discussed with the patients.

If a woman who is being treated with TASIGNA is considering pregnancy, treatment discontinuation may be envisaged based on the eligibility criteria for discontinuing treatment as described in sections on **DOSAGE AND ADMINISTRATION**. There is limited data on pregnancies in patients while attempting treatment-free remission (TFR). If a pregnancy is planned during the TFR phase, the patient must be informed of a potential need to re-initiate treatment with TASIGNA during the pregnancy (see sections on **DOSAGE AND ADMINISTRATION** and **WARNINGS AND PRECAUTIONS, Pregnant Women**).

Nursing Women

Animal studies demonstrate that nilotinib is excreted into breast milk of rats (see **TOXICOLOGY, Animal pharmacokinetics**). Women taking TASIGNA should not breast-feed while taking TASIGNA and for 2 weeks after the last dose, as a risk to the infant cannot be excluded.

Male Patients

It is not known if nilotinib is present in semen. Sexually active male patients must always use highly effective contraception during the treatment and for at least 4 weeks after ending TASIGNA therapy. There are post-market reports for pregnancies occurring in the female partners of male

patients who were receiving TASIGNA. Outcomes include spontaneous abortions, premature delivery and fetal abnormalities (see **ADVERSE REACTIONS, Post-Market Adverse Reactions**).

Therefore, male patients must be advised to inform their female sexual partners that they are taking TASIGNA. Male patients should also advise their female partners of the potential serious risks to a developing fetus should pregnancy occur during her partner's treatment with TASIGNA.

Females of Childbearing Potential

Females of child-bearing potential are all females who are menstruating, or who are physiologically capable of becoming pregnant.

TASIGNA can cause fetal harm should pregnancy occur (See **WARNINGS AND PRECAUTIONS, Pregnant Women**). Female of childbearing potential must be advised to use highly effective method of contraception while receiving TASIGNA and at least 4 weeks after ending treatment. Highly effective contraception is a method of birth control which results in a low failure rate (i.e. less than 1% per year) when used consistently and correctly. If a patient becomes pregnant while taking TASIGNA, the benefits of therapy versus the potential risks of the fetus should be evaluated by the physician and the treatment options should be discussed with the patients.

Pediatric Patients (2-17 years of age)

There is no experience with TASIGNA in pediatric patients below 2 years of age.

The long-term effects of prolonged treatment with TASIGNA in pediatric patients are unknown. There have been case reports of growth retardation in pediatric patients treated with TASIGNA. Inform pediatric patients and their caregivers of the possibility of developing growth abnormalities (see **ADVERSE REACTIONS, Growth Retardation in Pediatric Patients**). Growth and development in pediatric patients receiving TASIGNA should be closely monitored (see **Monitoring and Laboratory Tests**).

Discontinuation of TASIGNA treatment to attempt the treatment-free remission phase in pediatric patients has not been assessed.

Geriatrics (≥ 65 years of age)

Approximately 12% and 30% of subjects in the clinical studies (Phase III study (A2303) in newly diagnosed Ph⁺ CML-CP; and Phase II study (A2101) in resistant or -intolerant Ph⁺ CML-CP and CML-AP) were 65 years of age or older respectively. No major differences were observed for safety and efficacy in patients ≥65 years of age as compared to adults 18 to 65 years of age.

Monitoring and Laboratory Tests

Complete blood counts should be performed every two weeks for the first 2 months and then monthly thereafter or as clinically indicated (See **WARNINGS AND PRECAUTIONS**).

Electrocardiograms (ECGs) should be obtained before treatment, seven days after initiation and periodically thereafter, as well as following dose adjustments (See **WARNINGS AND PRECAUTIONS** and **DOSAGE AND ADMINISTRATION**).

Liver function, (transaminases, total bilirubin and alkaline phosphatase) needs to be monitored before treatment, frequently during treatment, following dose adjustments or as clinically indicated (see **WARNINGS AND PRECAUTIONS; DOSAGE AND ADMINISTRATION; TOXICOLOGY**).

Serum electrolytes (including phosphorus, potassium and magnesium) as well as serum lipase/amylase, fasting glucose, HbA1C, creatine kinase (CPK), uric acid, creatinine, and lactate dehydrogenase (LDH) levels need to be monitored before treatment and frequently during treatment with TASIGNA and as clinically indicated (See **WARNINGS AND PRECAUTIONS** and **DOSAGE AND ADMINISTRATION**).

Patients with symptomatic PAOD should be monitored and actively managed during TASIGNA therapy according to standard guidelines.

Adequate hydration should be maintained if tumor lysis syndrome is considered a substantial risk.

In a Phase III study in newly diagnosed CML patients, 1.1% of the patients treated with 400 mg TASIGNA twice a day, had a Grade 3/4 elevation in total serum cholesterol; however, there were no Grade 3/4 elevations in the group receiving the recommended dose of 300 mg twice a day (See **ADVERSE REACTIONS/Investigations**). It is recommended that the lipid profiles be determined before initiating treatment with TASIGNA, assessed at month 3 and 6 after initiating therapy, and at least yearly during therapy (See **ADVERSE REACTIONS** and **DOSAGE AND ADMINISTRATION/ Dose Adjustments or Modifications**). If test results warrant therapy, physicians should follow their local standards of practice and treatment guidelines. If lipid lowering agents are needed, please refer to **Drug-Drug Interactions** section before starting treatment.

Patients should be weighed and monitored regularly for signs and symptoms of fluid retention (see **WARNINGS AND PRECAUTIONS**). If therapeutic measures include the use of medications, please refer to **Drug-Drug Interactions** section before starting treatment.

Growth and physical development should be monitored using standard parameters in pediatric patients receiving TASIGNA.

Monitoring of BCR-ABL transcript levels in patients who discontinued TASIGNA:

Monitoring of *BCR-ABL* transcript levels in patients eligible for treatment discontinuation, during TFR and re-treatment, must be performed with a quantitative diagnostic test validated to measure molecular response levels with a sensitivity of at least MR4.5 ($BCR-ABL/ABL \leq 0.0032\%$ IS).

In patients who discontinue TASIGNA therapy, monitor complete blood count (CBC) and *BCR-ABL* transcript levels monthly for one year, then every 6 weeks for the second year, and every 12 weeks thereafter during treatment discontinuation.

Newly diagnosed patients must reinitiate TASIGNA therapy within 4 weeks of a loss of Major Molecular Response (MMR, corresponding to MR3.0 or $BCR-ABL/ABL \leq 0.1\%$ IS).

Patients resistant or intolerant to prior treatment which included imatinib must reinitiate TASIGNA therapy within 4 weeks of a loss of MMR or confirmed loss of MR4.0 (two consecutive measures separated by at least 4 weeks showing loss of MR4.0, corresponding to $BCR-ABL/ABL \leq 0.01\%$ IS).

For patients who fail to achieve MMR after three months of treatment re-initiation, *BCR-ABL* kinase domain mutation testing should be performed.

Monitoring of *BCR-ABL* Transcript Levels in Patients who have Reinitiated Therapy after Loss of Molecular Response: Monitor CBC and *BCR-ABL* transcript levels in patients who reinitiate therapy due to loss of molecular response quantitation monthly until MMR is re-established and every 12 weeks thereafter.

ADVERSE REACTIONS

Adverse Drug Reaction Overview

Sudden Cardiac Deaths

From clinical trials including the Phase II study (A2101), the Expanded Access Program, and the Compassionate Use Program, 19 cases of sudden cardiac deaths have been reported out of 11,351 patients receiving TASIGNA (uncommon frequency of 0.17%). Of the 19 cases, 13 documented cases had a past medical history of cardiac disease or significant cardiac risk factors for sudden cardiac death. In 4 of the 19 cases of sudden cardiac death, patients had no prior medical history of cardiac disease. Comorbidities in addition to the underlying malignancy were also frequently present as were concomitant medications. Ventricular repolarization abnormalities may have been contributory factors. No cases of sudden cardiac deaths have been reported in any treatment group in the newly diagnosed Ph+ CML-CP Phase III study.

Clinical Trial Adverse Drug Reactions

Summary of the safety profile

The TASIGNA safety profile described below is based on data from adult patients with newly diagnosed Ph+ CML-CP in a randomized, open label, active comparator-controlled Phase-III trial and adult patients with resistant or intolerant Ph+ CML-CP and CML-AP which served as a basis for the market authorized indications (see **Table 1** and **INDICATIONS AND CLINICAL USE**). Safety information from two TASIGNA treatment discontinuation studies (I2201 and A2408) is also provided.

In adult patients with newly diagnosed Ph+ CML-CP

The data reported below reflect exposure to TASIGNA from a randomized Phase III study (A2303) in adult patients with newly diagnosed Ph+ CML in chronic phase (CP) treated at the

recommended dose of TASIGNA 300 mg twice daily (N=279), with a median time on treatment of 60.5 months (range 0.1 – 70.8 months). Among the patients with newly diagnosed Ph+ CML-CP treated with TASIGNA at 400 mg twice daily (N=277), the median time on treatment was 60.7 months (range 0.2 – 71.8 months).

The very common ($\geq 10\%$) non-hematologic adverse drug reactions (ADRs) were rash, pruritus, headache, nausea, alopecia, myalgia, and fatigue in the TASIGNA 300 mg twice daily group and 400 mg twice daily group. Most of these ADRs were mild to moderate in severity (Grade 1 or 2). Upper abdominal pain was very frequent in the 300 mg twice daily group and less frequent in the 400 mg twice daily group, whereas arthralgia and dry skin were very frequent in the 400 mg twice daily group and less frequent in the 300 mg twice daily group.

Diarrhea, constipation, muscle spasms, vomiting, abdominal pain, peripheral oedema, dyspepsia, and asthenia were less frequent ($< 10\%$ and $\geq 5\%$) in the TASIGNA 300 mg twice daily group and 400 mg twice daily group. They were mild to moderate severity, manageable and generally did not require dose reduction. In addition, erythema, and bone pain were less frequent ($< 10\%$ and $\geq 5\%$) in the 300 mg twice daily group whereas pain in the extremity was observed less frequently ($< 10\%$ and $\geq 5\%$) in the 400 mg twice daily group.

Pleural and pericardial effusions occurred in $< 1\%$ of patients, receiving TASIGNA 300 mg twice daily and TASIGNA 400 mg twice daily. Grade 3 or 4 pleural effusion occurred in a patient receiving TASIGNA 300 mg twice daily.

Gastrointestinal hemorrhage, regardless of causality, was reported in 3% in patients receiving TASIGNA 300 mg twice daily and in 5% patients receiving TASIGNA 400 mg twice daily.

The maximum QTcF mean increase from baseline in the TASIGNA 300 mg twice daily group was 12.3-msec (two-sided 90% Upper CI: 14.4) and the maximum QTcF mean increase from baseline in the TASIGNA 400 mg twice daily group was 12.9-msec (two-sided 90% Upper CI: 15.1).

No patient had an absolute QTcF of > 500 msec while on treatment drug in any of the TASIGNA treatment groups and no events of Torsades de Pointes were observed. One patient in the 400 mg twice daily arm had an absolute QTcF of > 480 msec. QTcF increase from baseline that exceeds 60 msec was observed in 5 patients while on TASIGNA (one in the TASIGNA 300 mg twice daily treatment group and four in the TASIGNA 400 mg twice daily treatment group). No patients in any treatment group had a LVEF $< 45\%$ during treatment. Also, there were no patients with 15% or greater decrease from baseline in LVEF.

No sudden cardiac deaths have been reported in any treatment group.

Hematologic ADRs include myelosuppression in patients receiving TASIGNA 300 mg twice daily and 400 mg twice daily respectively: thrombocytopenia (18%; 20%), neutropenia (15%; 11%), and anemia (8%; 9%). Biochemistry ADRs in patients receiving TASIGNA 300 mg twice daily and 400 mg twice daily, respectively include: alanine aminotransferase increased (24%; 29%), hyperbilirubinemia (17%; 17%), aspartate aminotransferase increased (12%; 15%), lipase increased (11%; 10%), blood bilirubin increased (10%; 14%), hyperglycemia (4%; 5%), hypercholesterolemia (3%; 6%), and hypertriglyceridemia ($< 1\%$; 1%). See **Table 2** for Grade 3/4 laboratory abnormalities.

Discontinuation due to adverse drug reactions was observed in 10% of patients receiving TASIGNA 300 mg twice daily and in 17% of patients receiving TASIGNA 400 mg twice daily.

In adult patients with resistant or intolerant Ph+ CML-CP and CML-AP

The data reported below reflect exposure to TASIGNA in 458 adult patients with Ph+ CML-CP and CML-AP resistant to or intolerant to at least one prior therapy including imatinib (321 CML-CP patients and 137 CML-AP patients, respectively) in an open-label multicenter study. Patients were treated at the recommended dose of 400 mg twice daily.

Non-hematologic adverse drug reactions (ADRs) reported with very common frequency ($\geq 10\%$ in the combined CML-CP and CML-AP patient populations) were rash, pruritus, nausea, fatigue, headache, constipation and diarrhea, vomiting and myalgia. Most of these ADRs were mild to moderate in severity. Alopecia, muscle spasms, decreased appetite, arthralgia, bone pain, abdominal pain, peripheral oedema and asthenia were observed less frequently ($< 10\%$ and $\geq 5\%$) and have been of mild to moderate severity (Grade 1 or 2).

Pleural and pericardial effusions as well as complications of fluid retention occurred in $< 1\%$ of patients receiving TASIGNA.

Cardiac failure was observed in $< 1\%$ of patients. QTcF exceeding 500 msec was observed in this study in 4 patients ($< 1\%$). No episodes of Torsades de Pointes (transient or sustained) were observed.

Gastrointestinal and CNS hemorrhage was reported in 1% and $< 1\%$ of patients, respectively.

Hematologic ADRs include myelosuppression: thrombocytopenia (31%), neutropenia (17%), and anemia (14%). See Table 2 for Grade 3/4 laboratory abnormalities.

Discontinuation due to adverse drug reactions was observed in 16% of CP and 10% of AP patients.

Most Frequently Reported Adverse Drug Reactions

Non-hematologic ADRs (excluding laboratory abnormalities) that were reported in at least 5% of the adult patients in any of the TASIGNA clinical studies that serve as a basis for the listed indications are shown in Table 1. These are ranked under heading of frequency, the most frequent first. Within each frequency grouping adverse drug reactions are presented in order of decreasing seriousness. In addition the corresponding frequency category for each adverse drug reaction is based on the following convention: very common ($\geq 10\%$) or common ($\geq 1\%$ to $< 10\%$). The frequency is based on the highest for any TASIGNA group in the two studies, using one decimal precision for percentages.

Table 1 Most Frequently Reported Non-hematologic Adverse Drug Reactions ($\geq 5\%$ in any adult TASIGNA Group)

Newly Diagnosed Ph+ CML-CP 60 month analysis								Resistant or Intolerant Ph+ CML-CP and CML-AP 24-month analysis			
		TASIGNA 300 mg twice daily	TASIGNA 400 mg twice daily	GLEEVEC® 400 mg once daily	TASIGNA 300 mg twice daily	TASIGNA 400 mg twice daily	GLEEVEC® 400 mg once daily	TASIGNA 400 mg twice daily			
		ALL Grades (%)			Grade 3/4 (%)			ALL Grades (%)	Grade 3/4 (%)	CML-CP Grade 3/4 (%)	CML -AP Grade 3/4 (%)
System Organ Class	Adverse Reaction	N=279 %	N=277 %	N=280 %	N=279 %	N=277 %	N=280 %	N=458 %	N=458 %	N=321 %	N=137 %
Metabolism and nutrition disorders	Decreased appetite ¹	4	4	3	0	0	0	8	<1	<1	0
	Headache	16	22	10	2	1	<1	15	1	2	<1
Gastro intestinal disorders	Nausea	14	21	35	<1	1	<1	20	<1	<1	<1
	Constipation	10	7	3	0	<1	0	12	<1	<1	0
	Diarrhea	9	7	31	<1	0	3	11	2	2	<1
	Vomiting	6	9	19	0	1	0	10	<1	<1	0
	Abdominal pain upper	10	9	8	1	0	<1	5	<1	<1	0
	Abdominal pain	6	6	4	0	<1	0	6	<1	<1	<1
	Dyspepsia	5	5	6	0	<1	0	3	0	0	0
Skin and subcutaneous tissue disorders	Rash	33	39	14	<1	3	2	28	1	2	0
	Pruritus	18	16	5	<1	<1	0	24	<1	<1	0
	Alopecia	10	14	6	0	0	0	9	0	0	0

	Dry Skin	10	12	5	0	0	0	5	0	0	0
	Erythema	3	6	3	0	0	0	5	<1	<1	0
Musculo skeletal and connective tissue disorders	Myalgia	10	12	13	<1	<1	<1	10	<1	<1	<1
	Arthralgia	8	10	8	<1	0	<1	7	<1	1	0
	Muscle spasms	9	9	30	0	<1	1	8	<1	<1	0
	Bone pain	4	5	4	0	<1	<1	6	<1	<1	0
	Pain in extremity	5	3	8	<1	<1	<1	5	<1	<1	<1
General disorders and administration site conditions	Fatigue	12	11	13	0	<1	1	17	1	1	<1
	Asthenia	9	5	9	<1	<1	0	6	0	0	0
	Oedema peripheral	5	7	18	<1	0	0	6	0	0	0

¹ Also includes preferred term anorexia

Percentages are rounded to integer for presentation in this table. However, percentages with one decimal precision are used to identify terms with a frequency of at least 5% and to classify terms according to frequency categories

Less Common Clinical Trial Adverse Drug Reactions (< 5%)

Additional Data from Clinical Trials (Studies A2101 and A2303)

The following adverse drug reactions (ADRs) were reported in adult patients in the TASIGNA clinical studies which serve as a basis for the listed indications at the recommended doses at a frequency of less than 5% (common is $\geq 1\%$ to $< 10\%$; uncommon is $>0.1\%$ to $<1\%$); (single events are captured as Unknown in *frequency*- *Unknown*). For laboratory abnormalities, very common events ($\geq 10\%$) not included in Table 1 are also reported. These adverse reactions are included based on clinical relevance and ranked in order of decreasing seriousness within each category, obtained from two clinical studies: 1. Newly diagnosed Ph+ CML-CP 60 months' analysis and 2. Resistant or intolerant Ph+ CML-CP and CML-AP 24 months' analysis.

Cardiac Disorders:

Common: angina pectoris, arrhythmia (including atrioventricular block, cardiac flutter, extrasystoles, atrial fibrillation, tachycardia, bradycardia), cardiac failure, palpitations, electrocardiogram QT prolonged.

Uncommon: myocardial infarction, coronary artery disease, cardiac murmur pericardial effusion, deep vein thrombosis, cyanosis

Unknown frequency: myocarditis, ventricular dysfunction, pericarditis, ejection fraction decrease, congenital transposition of great vessels in neonate (fatal), ventricular arrhythmia, cardiac valve disorders

Infections and Infestations:

Common: folliculitis, upper respiratory tract infection (including pharyngitis, nasopharyngitis, rhinitis).

Uncommon: pneumonia, bronchitis, urinary tract infection, herpes virus infection, candidiasis (including oral candidiasis), gastroenteritis

Unknown frequency: sepsis, subcutaneous abscess, anal abscess, furuncle, tinea pedis, hepatitis B virus reactivation.

Neoplasms Benign, Malignant and Unspecified:

Common: skin papilloma.

Unknown frequency: oral papilloma, paraproteinemia.

Blood and Lymphatic System Disorders:

Common: leukopenia, eosinophilia, febrile neutropenia, pancytopenia, lymphopenia.

Unknown frequency: thrombocythemia, leukocytosis.

Endocrine Disorders:

Uncommon: hyperthyroidism, hypothyroidism.

Unknown frequency: hyperparathyroidism secondary, thyroiditis.

Metabolism and Nutrition Disorders:

Very common: hypophosphatemia (including blood phosphorus decreased).

Common: electrolyte imbalance (including hypomagnesemia, hyperkalemia, hypokalemia, hyponatremia, hypocalcemia, hypercalcemia, hyperphosphatemia), diabetes mellitus

(uncommonly specified as Types 1 or 2 diabetes mellitus), hyperglycemia, hypercholesterolemia, hypertriglyceridemia, hyperlipidemia.

Uncommon: gout, dehydration, increased appetite, new-onset diabetes, dyslipidemia

Unknown frequency: hyperuricemia, hypoglycemia.

Psychiatric Disorders:

Common: depression, insomnia, anxiety.

Unknown frequency: disorientation, confusional state, amnesia, dysphoria.

Nervous System Disorders:

Common: dizziness, peripheral neuropathy, hypoaesthesia, paresthesia.

Uncommon: intracranial hemorrhage, ischemic stroke, transient ischemic attack, cerebral infarction, migraine, loss of consciousness (including syncope), tremor, disturbance in attention, hyperesthesia.

Unknown frequency: cerebrovascular accident, basilar artery stenosis, brain oedema, optic neuritis, lethargy, dysaesthesia, restless legs syndrome.

Eye Disorders:

Common: eye hemorrhage, periorbital oedema, eye pruritus, conjunctivitis, dry eye (including xerophthalmia).

Uncommon: vision impairment, vision blurred, visual acuity reduced, eyelid oedema, photopsia, hyperaemia (scleral, conjunctival, ocular), eye irritation, conjunctival hemorrhage.

Unknown frequency: papilloedema, diplopia, photophobia, eye swelling, blepharitis, eye pain, chorioretinopathy, conjunctivitis allergic, ocular surface disease.

Ear and Labyrinth Disorders:

Common: vertigo.

Unknown frequency: hearing impaired, ear pain, tinnitus.

Immune System Disorders:

Unknown frequency: vasculitis (cerebral, leukocytoclastic), hypersensitivity.

Vascular Disorders:

Common: hypertension, flushing.

Uncommon: hypertensive crisis, peripheral arterial occlusive disease (including femoral artery stenosis), coronary artery stenosis, carotid artery stenosis, arterial stenosis limb, cerebrovascular accident, hematoma, arteriosclerosis.

Unknown frequency: shock hemorrhagic, arteriosclerosis obliterans, hypotension, thrombosis, cerebral infarction, cerebral hemorrhage, amnesic disorder, peripheral vascular disorder, intermittent claudication, vasculitis, circulatory collapse, venous stenosis, arterial disorder, femoral artery occlusion, aortic arteriosclerosis, peripheral ischaemia, arterial occlusive disease, arteritis obliterans, extravasation blood, vascular graft occlusion, peripheral artery stenosis.

Respiratory, Thoracic and Mediastinal Disorders:

Common: dyspnea, dyspnea exertional, epistaxis, cough, dysphonia.

Uncommon: pulmonary oedema, pleural effusion, interstitial lung disease, pleuritic pain, pleurisy, pharyngolaryngeal pain, throat irritation.

Unknown frequency: pulmonary hypertension, wheezing, oropharyngeal pain.

Gastrointestinal Disorders:

Common: acute pancreatitis, abdominal discomfort, abdominal distension, dyspepsia, dysgeusia, flatulence.

Uncommon: gastrointestinal hemorrhage, melaena, mouth ulceration, gastroesophageal reflux, stomatitis, oesophageal pain, dry mouth, gastritis, sensitivity of teeth.

Unknown frequency: gastrointestinal ulcer perforation, retroperitoneal hemorrhage, hematemesis, gastric ulcer, esophagitis ulcerative, subileus, enterocolitis, hemorrhoids, hiatus hernia, rectal hemorrhage, gingivitis.

Hepatobiliary Disorders:

Very common: hyperbilirubinemia (including blood bilirubin increased).

Common: hepatic function abnormal.

Uncommon: hepatic failure, hepatotoxicity, toxic hepatitis, ascites, jaundice.

Unknown frequency: cholestasis, hepatic necrosis, hepatic steatosis, hepatomegaly.

Skin and Subcutaneous Tissue Disorders:

Common: night sweats, eczema, urticaria, hyperhidrosis, contusion, acne, dermatitis, (including allergic, exfoliative and acneiform).

Uncommon: exfoliative rash, drug eruption, pain of skin, ecchymosis, swelling face.

Unknown frequency: psoriasis, erythema multiforme, skin fissures, erythema nodosum, skin ulcer, palmar-plantar erythrodysesthesia syndrome, petechiae, photosensitivity, blister, dermal cyst, sebaceous hyperplasia, skin atrophy, skin discolouration, skin exfoliation, skin hyperpigmentation, skin hypertrophy, hyperkeratosis.

Musculoskeletal and Connective Tissue Disorders:

Common: musculoskeletal chest pain, musculoskeletal pain, back pain, neck pain, flank pain, muscular weakness.

Uncommon: musculoskeletal stiffness, joint swelling.

Unknown frequency: rhabdomyolysis, arthritis.

Renal and Urinary Disorders:

Common: pollakiuria.

Uncommon: dysuria, micturition urgency, nocturia, acute renal failure.

Unknown frequency: renal failure, hematuria, urinary incontinence, chromaturia.

Reproductive System and Breast Disorders:

Uncommon: breast pain, gynecomastia, erectile dysfunction.

Unknown frequency: breast induration, menorrhagia, nipple swelling.

General Disorders and Administration Site Conditions:

Common: pyrexia, chest pain (including non-cardiac chest pain), pain chest discomfort, malaise.

Uncommon: face edema, gravitational edema, influenza-like illness, chills, feeling body temperature change (including feeling hot, feeling cold).

Unknown frequency: localised oedema.

Investigations:

Very common: alanine aminotransferase increased, aspartate aminotransferase increased, lipase increased, lipoprotein cholesterol (including low density and high density) increased, total cholesterol increased, blood triglycerides increased.

Common: prothrombin time (INR) increased¹, hemoglobin decreased, blood amylase increased, gamma-glutamyltransferase increased, blood creatine phosphokinase increased, blood alkaline phosphatase increased, weight decreased, blood insulin increased, weight increased, globulins decreased.

Uncommon: blood lactate dehydrogenase increased, blood urea increased.

Unknown frequency: troponin increased, blood potassium decreased, blood bilirubin unconjugated increased, blood insulin decreased, insulin C-peptide decreased, blood parathyroid hormone increased.

¹ Prolongation of prothrombin time (INR) was reported with common frequency in patients receiving TASIGNA, however causal relationship with TASIGNA has not been confirmed.

Second malignancies in TASIGNA-treated patients:

There are reports of second cancers (gastric cancer, gastrointestinal stromal tumour, pancreatic carcinoma, pancreatic neuroendocrine tumour, colon cancer, malignant melanoma in situ, ovarian epithelial cancer, skin cancer, and squamous cell carcinoma) in pooled clinical trials of patients treated with TASIGNA.

Abnormal Hematologic and Clinical Chemistry Findings – Adults

Clinically relevant or severe abnormalities of routine hematologic or biochemistry laboratory values in adult patients are presented in Table 2.

Table 2 Grade 3/4 Laboratory Abnormalities

	Newly diagnosed Adult Ph+ CML-CP			Resistant or intolerant Adult Ph+	
				CML-CP	CML-AP
	TASIGNA 300 mg twice daily N = 279	TASIGNA 400 mg twice daily N = 277	GLEEVEC 400 mg once daily N = 280	TASIGNA 400 mg twice daily N=321	TASIGNA 400 mg twice daily N=137
Hematologic Parameters					
Myelosuppression					
Neutropenia	12%	11%	22%	31%	42%
Thrombocytopenia	10%	12%	9%	30%	42%
Anemia	4%	5%	6%	11%	27%
Biochemistry Parameters					
Elevated creatinine	0%	0%	<1%	1%	<1%
Elevated lipase	9%	10%	4%	18%	18%

Elevated SGOT (AST)	1%	3%	1%	3%	2%
Elevated SGPT (ALT)	4%	9%	3%	4%	4%
Hypophosphatemia	8%	10%	10%	17%	15%
Elevated Bilirubin (total)	4%	9%	<1%	7%	9%
Hyperglycemia	7%	7%	<1%	12%	6%
Hyperkalemia	2%	1%	1%	6%	4%
Hyponatremia	1%	1%	<1%	7%	7%
Hypokalemia	<1%	1%	2%	2%	9%
Hypocalcemia	<1%	<1%	<1%	2%	5%
Decreased albumin	0%	0%	<1%	4%	3%
Elevated alkaline phosphatase	0%	0%	<1%	<1%	1%
Elevated cholesterol (total)	0	1%	0%	**	**
Elevated triglycerides	0%	<1%	0%	**	**

Percentages with one decimal precision are used and rounded to integer for presentation in this table.

* parameter not collected

Abnormal Electrocardiographic (ECG) Findings - Adults

In the Phase III study (A2303) in adults newly diagnosed with Ph+ CML-CP, no patient had an absolute QTcF exceeding 500 msec while on treatment in any of the treatment groups. QTcF increase from baseline that exceeds 60 msec was observed in 1 patient (0.4%) in the TASIGNA 300 mg twice daily treatment group and 4 (1.4%) in the TASIGNA 400 mg twice daily treatment group (See Table 3). No episodes of Torsades de Pointes were observed.

In the Phase II study (A2101) in adults with imatinib-resistant or -intolerant CML in CP and AP, QTcF exceeding 500 msec was observed in 4 patients (1.2%) of CML-CP patients. QTcF > 60 msec increase from baseline was observed in the combined CML-CP and –AP patient populations (CML-CP 8 (2.5%) and CML-AP 11 (8%)) (See Table 4). No episodes of Torsades de Pointes (transient or sustained) were observed (see **WARNINGS AND PRECAUTIONS** and **ADVERSE REACTIONS**).

Table 3 Number (%) of newly diagnosed Ph+ CML-CP adult patients with notable values in QTcF intervals-Study A2303

ECG Parameter	TASIGNA 300 mg twice daily N = 279 n (%)	TASIGNA 400 mg twice daily N = 277 n (%)	GLEEVEC 400 mg once daily N= 280 n (%)
Increase from baseline > 30 msec	94 (33.7)	91 (32.9)	82 (29.3)
Increase from baseline > 60 msec	1 (0.4)	4 (1.4)	4 (1.4)

Absolute value > 450 msec	32 (11.5)	40 (14.4)	41 (14.6)
Absolute value > 480 msec	0	1 (0.4)	2 (0.7)
Absolute value > 500 msec	0	0	1 (0.4)

Table 4 Number (%) of imatinib- resistant or -intolerant Ph+ CML-CP and CML-AP adult patients with notable values in QTcF intervals-Studies 2101E2 and 2101E1

ECG Parameter	CML-CP (2101E2) N= 321 n (%)	CML-AP (2101E1) N= 137 n (%)	Total N= 458 n (%)
Increase from baseline > 30 msec	144 (44.9)	65 (47.4)	209 (45.6)
Increase from baseline > 60 msec	8 (2.5)	11 (8.0)	19 (4.1)
Absolute value > 450 msec	51(15.9)	24	75(16.4)
Absolute value > 480 msec	7 (2.2)	4 (2.9)	11(2.4)
Absolute value > 500 msec	4 (1.2)	0 (0.0)	4 (0.9)

n= number of patients who meet the criterion for at least one post-baseline value.

Treatment discontinuation in Ph+ CML-CP patients who have achieved a sustained molecular response (MR4.5)

In eligible patients who discontinued TASIGNA therapy after attaining a sustained MR4.5, musculoskeletal symptoms (e.g. myalgia, pain in extremity, arthralgia, bone pain, spinal pain, or musculoskeletal pain), were reported more frequently than before treatment discontinuation in the first year, as noted in Table 5. The frequency of new musculoskeletal symptoms generally decreased in the second year after treatment discontinuation.

In the newly diagnosed population in whom musculoskeletal symptoms occurred at any time during the TFR phase, for 23/53 patients (43.4%) the event had not resolved by the TFR end date or as of the 96-weeks TFR analysis data cut-off date. In the population previously treated with imatinib in whom musculoskeletal events occurred at any time during the TFR phase, for 32/57 patients (56.1%) the event had not resolved by the TFR end date or by the data cut-off date.

The frequency of musculoskeletal symptoms decreased in patients who entered the TASIGNA treatment re-initiation (NTRI) phase, to 11/88 patients (12.5%) in the newly diagnosed population and to 14/56 patients (25%) in the population previously treated with imatinib. Other adverse reactions observed in the TASIGNA re-treatment phase were similar to those observed during TASIGNA use in patients with newly diagnosed Ph+ CML-CP and resistant or intolerant Ph+ CML-CP and CML-AP.

Table 5 Musculoskeletal symptoms occurring upon treatment discontinuation in the context of treatment-free remission (TFR)

Ph+ CML-CP patients	Entire TFR period in all TFR patients				By time interval, in subset of patients in TFR greater than 48 weeks						
	N	Median follow-up in TFR	Patients with musculoskeletal symptoms		N	Year prior to TASIGNA discontinuation		1 st year after TASIGNA discontinuation		2 nd year after TASIGNA discontinuation	
			All grades	Grade 3/4		All grades	Grade 3/4	All grades	Grade 3/4	All grades	Grade 3/4
Newly Diagnosed	190	76 weeks	27.9%	1.1%	100	17.0%	0%	34.0%	2.0%	9.0%	0%
Previously treated with imatinib	126	99 weeks	45.2%	2.4%	73	13.7%	0%	47.9%	2.7%	15.1%	1.4%

Safety of TASIGNA in Pediatric Patients with Newly Diagnosed or Resistant/Intolerant Ph+ CML-CP

The safety of TASIGNA in pediatric patients (from 2 to <18 years of age) with Ph+ CML-CP (N=69) has been investigated in two open-label single arm studies, (Phase II, CAMN107A2203 and Phase I, CAMN107A2120) (see **CLINICAL TRIALS**). The frequency, type and severity of observed adverse reactions have been generally consistent with those observed in adults. The most common newly occurring or worsening hematological laboratory abnormalities ($\geq 30\%$ of patients, all grades) were decreases in total white blood cells (54%), platelet count (44%), absolute neutrophils (41%), absolute lymphocytes (32%), and hemoglobin (30%). The most common (>20%) non-hematologic adverse drug reactions were headache, rash, blood bilirubin increased, alanine aminotransferase increased, pyrexia, nausea, upper respiratory tract infection, aspartate aminotransferase increased and vomiting. Liver-related laboratory abnormalities of hyperbilirubinaemia (Grade 3/4: 13.0%) and transaminase elevation (AST Grade 3/4: 1.4%, ALT Grade 3/4: 8.7%) were reported at a higher frequency than in adult patients. Bilirubin and hepatic transaminase levels should be monitored during treatment (see **DOSAGE AND ADMINISTRATION** and **Monitoring and Laboratory Tests**). Increase in QTcF >30 msec from baseline was observed in 17 pediatric patients (25%). Increase in QTcF >450 msec was observed in 4 pediatric patients (6.0%), increase in QTcF > 480 msec was observed in 3 pediatric patients (4.4 %). No patient had an absolute QTcF > 500msec or QTcF increase of > 60 msec from baseline.

Growth Retardation in Pediatric Patients:

In the Phase II pediatric study CAMN107A2203 (n=58), with a median exposure of 33 months to TASIGNA, adverse drug reactions of mild and moderate severity associated with growth and deceleration of growth in regard to the height were reported in 3 patients (5.2%) including growth retardation in 2 adolescent patients and growth hormone deficiency with body height below normal in the remaining patient (10 to 13 years old). Twelve percent (n = 7) of patients had growth deceleration as demonstrated by a decrease of two main height percentile lines (percentile lines:

5 th, 10th, 25th , 50th, 75th, 90th, and 95th) on their growth chart during their treatment with TASIGNA.

No negative effects were observed in relation to the bone age or bone biomarkers and no delayed puberty was observed.

Post-Market Adverse Reactions

The following adverse reactions have been derived from post marketing experience with TASIGNA via spontaneous case reports, literature cases, expanded access programs, and clinical studies other than the global registration trials. The criteria for including these adverse reactions is based on the seriousness. Because these reactions are reported voluntarily from a population of uncertain size, it is not always possible to reliably estimate their frequency or establish a causal relationship to drug exposure.

Blood and lymphatic: splenic infarction

Cardiovascular: anaphylaxis, cardiac tamponade (fatal), Torsades de Pointes, tricuspid valve incompetence, aortic valve sclerosis, coeliac artery stenosis, disseminated intravascular coagulation

Congenital, familial and genetic: Encephalocele, omphalocele, transposition of great vessels, venous angioma of brain, cerebellar hypoplasia

Ear and labyrinth: deafness

Endocrine and Metabolism: fluid overload, tumor lysis syndrome

Eye: cataract, blindness, conjunctivitis, ocular hyperaemia, visual impairment, eye haemorrhage, periorbital oedema, retinal haemorrhage, optic nerve infarction, optic ischaemic neuropathy, arteriosclerotic retinopathy, optic neuropathy, retinal artery occlusion, optic neuritis

General: gait disturbance

Hepatobiliary: hepatorenal syndrome, diverticular perforation, intestinal perforation, gastric ulcer haemorrhage

Immune: aphthous stomatitis

Infections and infestations: Clostridium difficile colitis, lower respiratory tract infection, pelvic abscess, pneumonia primary atypical, septic shock, swine influenza

Injury, poisoning and procedural complications: In-stent arterial restenosis

Investigations: blood phosphorus increased, positive Rombergism, urine output decreased

Neoplasms benign, malignant and unspecified (incl cysts and polyps): biliary adenoma, biliary neoplasm, lung neoplasm malignant, renal cancer, transitional cell carcinoma, lymphoma, leukemia, myelodysplastic syndrome, skin papilloma, thyroid neoplasm, oesophageal adenocarcinoma, throat cancer, rhabdomyosarcoma, metastases to central nervous system, malignant lung neoplasm, bronchial carcinoma, acute lymphocytic leukemia, acute leukemia, squamous cell carcinoma of skin, malignant melanoma, penis carcinoma, carcinoid tumour of

small bowel, ovarian cancer, basal cell carcinoma, myelofibrosis, colon cancer, gastrointestinal stromal tumour

Nervous system: convulsion, hepatic encephalopathy, intracranial pressure increased, spinal cord infarction, paralysis, IIIrd nerve paralysis, VIth nerve paralysis, cerebellar infarction, brain herniation

Pregnancy, puerperium and perinatal conditions: Spontaneous abortions, stillbirth, and foetal death

Psychiatric: bipolar disorder, hallucination

Renal and urinary: calculus ureteric, tubulointerstitial nephritis, urine flow decreased

Respiratory: acute respiratory distress syndrome, acute respiratory failure, bronchospasm, hypoxia, pulmonary embolism, respiratory failure, tachypnoea

Skin and subcutaneous: Stevens-Johnson syndrome, skin necrosis, palmar-plantar erythrodysesthesia syndrome, exfoliative dermatitis, toxic epidermal necrolysis

Vascular: venous insufficiency, vertebral artery occlusion, cerebral artery stenosis, carotid artery thrombosis, carotid artery occlusion, cerebral artery occlusion, arterial occlusive disease, necrotising vasculitis, aortic stenosis, peripheral embolism, arterial haemorrhage, embolism venous, venous thrombosis, vascular occlusion, veno-occlusive disease

DRUG INTERACTIONS

Overview

Drug-Drug Interactions

Serious Drug and Drug-Food Interactions

- CYP3A4 inhibitors should be avoided as they can increase nilotinib serum concentrations.
- Concomitant use of drugs that prolong QT interval should be avoided.
- Co-administration with drugs with a narrow therapeutic index and that are eliminated by certain enzymes.
- TASIGNA absorption is increased if taken with food. TASIGNA must not be taken with food and should be taken 2 hours after a meal. No food should be consumed at least 1 hour after the drug is taken.

Nilotinib is mainly metabolized in the liver, and is also a substrate for the multi-drug efflux pump, P-glycoprotein (P-gp). Therefore, absorption and subsequent elimination of systemically absorbed nilotinib may be influenced by drugs that affect CYP3A4 and/or P-gp. Interaction studies have not been performed in the pediatric population.

Drugs That May Increase Nilotinib Serum Concentrations

The administration of TASIGNA with agents that are strong CYP3A4 inhibitors should be avoided. Should treatment with any of these agents be required, it is recommended that therapy with TASIGNA be interrupted if possible. If transient interruption of treatment with TASIGNA is not possible, close monitoring of the individual for prolongation of the QT-interval is indicated (see **DOSAGE AND ADMINISTRATION** and **ACTION AND CLINICAL PHARMACOLOGY**).

In a Phase I study of nilotinib given in combination with imatinib (a substrate of P-gp and CYP3A4), both drugs had individually an inhibitory effect on CYP3A4 and/or P-gp. When the two drugs were administered concomitantly, the AUC of imatinib was increased by 18% to 39%, and the AUC of nilotinib was increased by 18% to 40%.

The bioavailability of nilotinib in healthy subjects was increased by 3-fold when co-administered with the strong CYP3A4 inhibitor **ketoconazole**. Concurrent treatment with strong CYP3A4 inhibitors should therefore be avoided (including but not limited to **ketoconazole, itraconazole, voriconazole, ritonavir, clarithromycin, and telithromycin**). For additional drugs, also refer to <http://www.intermed-rx.ca> (see **DOSAGE AND ADMINISTRATION** and **WARNINGS AND PRECAUTIONS** regarding QT prolongation). Alternative concomitant medications with no or minimal CYP3A4 inhibition should be considered.

Drugs That May Decrease Nilotinib Serum Concentrations

In healthy subjects receiving the CYP3A4 inducer, **rifampicin**, at 600 mg daily for 12 days, systemic exposure (AUC) to TASIGNA was decreased approximately 80%.

Inducers of CYP3A4 activity could increase the metabolism of nilotinib and thereby decrease plasma concentrations of nilotinib. The concomitant administration of medications that induce CYP3A4 (e.g. **phenytoin, rifampin carbamazepine, phenobarbital, and St. John's Wort**) may reduce exposure to nilotinib to a clinically relevant extent. In patients for whom CYP3A4 inducers are indicated, concomitant use of alternative therapeutic agents with less potential for CYP3A4 enzyme induction potential should be considered. For additional drugs, also refer to <http://www.intermed-rx.ca>.

Nilotinib has pH-dependent solubility, with lower solubility at higher pH. In 22 healthy subjects receiving multiple doses of esomeprazole at 40 mg once daily for 5 days, gastric pH was markedly increased. Co-administration of a single 400 mg dose of nilotinib and 40 mg esomeprazole was associated with a modest decrease in nilotinib absorption (27% decrease in nilotinib C_{max} and 34% decrease in nilotinib $AUC_{0-\infty}$). TASIGNA may be used concurrently with esomeprazole or other proton pump inhibitors as needed.

In a study with 52 healthy subjects, no significant change in nilotinib pharmacokinetics was observed when a single 400 mg dose of TASIGNA was administered 10 hours after and 2 hours

before famotidine. Therefore, when the concurrent use of an H2 blocker is necessary, it may be administered approximately 10 hours before and approximately 2 hours after the dose of TASIGNA.

In the same study as above, administration of a “non-absorbable” antacid (aluminum hydroxide/magnesium hydroxide/simethicone) 2 hours before or after a single 400 mg dose of TASIGNA also did not alter nilotinib pharmacokinetics. Therefore, if necessary, a “non-absorbable” antacid may be administered approximately 2 hours before or approximately 2 hours after the dose of TASIGNA.

Drugs That May Have Their Systemic Concentration Altered By Nilotinib

In vitro nilotinib is identified as a competitive inhibitor of CYP3A4, CYP2C8, CYP2C9, and CYP2D6 and UGT1A1, with K_i value being lowest for CYP2C9 ($K_i=0.13 \mu\text{M}$) (Substrates of UGT1A1: including but not limited to **buprenorphine, phenytoin**). A single-dose drug-drug interaction study with 25 mg warfarin, a sensitive CYP2C9 substrate, and 800 mg nilotinib was conducted in 24 healthy subjects. Nilotinib at clinically relevant concentrations was not found to alter the pharmacokinetics or pharmacodynamics of warfarin, a sensitive CYP2C9 substrate. TASIGNA can be used concurrently with warfarin without increasing the anticoagulant effect. Due to lack of steady-state data, control of warfarin pharmacodynamic markers (INR or PT) following initiation of nilotinib therapy (at least during the first 2 weeks) is recommended.

In 19 CML patients, nilotinib administered at 400 mg twice daily for 12 days increased the systemic exposure (AUC) of a single 2 mg oral dose of midazolam (a substrate of CYP3A4) 2.6-fold. Nilotinib is a moderate CYP3A4 inhibitor. As a result, the systemic exposure of other drugs primarily metabolized by CYP3A4 (e.g. certain HMG-CoA reductase inhibitors or statins) may be increased when co-administered with nilotinib. Appropriate monitoring and dose adjustment may be necessary for drugs that are CYP3A4 substrates and have a narrow therapeutic index (including but not limited to opioids (alfentanil, fentanyl), immunosuppressants (cyclosporine, sirolimus and tacrolimus), vasoconstrictors (dihydroergotamine and ergotamine), and levothyroxine) when co-administered with nilotinib (see **Monitoring and Laboratory Tests**). For additional drugs, also refer to <http://www.intermed-rx.ca>.

Nilotinib is a P-gp inhibitor *in vitro*. Therefore, concentration of drugs which are substrates of P-gp (including but not limited to **verapamil, digoxin, morphine, phenytoin, cefazolin, cyclosporine A, ondansetron**) may be increased. Alternative concomitant medications which are not P-gp substrates should be considered.

Anti-arrhythmic Medicines and Other Drugs That May Prolong the QT Interval

Concomitant use of TASIGNA with **anti-arrhythmic medicines** (including, but not limited to **amiodarone, disopyramide, procainamide, quinidine and sotalol**) and other drugs that may prolong the QT interval (including, but not limited to **chloroquine, halofantrine, clarithromycin, and other macrolides, haloperidol, methadone, moxifloxacin, bepridil and pimozide**) should be avoided. (see **WARNINGS AND PRECAUTIONS**).

Concomitant use of **anti-emetic medicines** (including but not limited to **metoclopramide, prochlorperazine, ondansetron and dolasetron**) should be avoided.

The concomitant use of TASIGNA with another QT/QTc-prolonging drug is discouraged. Drugs that have been associated with QT/QTc interval prolongation and/or Torsades de pointes include, but are not limited to, the examples in the following list. Chemical/pharmacological classes are listed if some, although not necessarily all, class members have been implicated in QT/QTc prolongation and/or Torsades de pointes:

- Class IA antiarrhythmics (e.g., quinidine, procainamide, disopyramide);
- Class III antiarrhythmics (e.g., amiodarone, sotalol, ibutilide);
- Class IC antiarrhythmics (e.g., flecainide, propafenone);
- antipsychotics (e.g., chlorpromazine, pimozide, haloperidol, droperidol, ziprasidone);
- antidepressants (e.g., fluoxetine, citalopram, venlafaxine, tricyclic/tetracyclic antidepressants e.g., amitriptyline, imipramine, maprotiline);
- opioids (e.g., methadone);
- macrolide antibiotics and analogues (e.g., erythromycin, clarithromycin, telithromycin, tacrolimus);
- quinolone antibiotics (e.g., moxifloxacin, levofloxacin, ciprofloxacin);
- pentamidine;
- antimalarials (e.g., quinine, chloroquine);
- azole antifungals (e.g., ketoconazole, fluconazole, voriconazole);
- domperidone;
- 5-hydroxytryptamine (5-HT)₃ receptor antagonists (e.g., dolasetron, ondansetron);
- tyrosine kinase inhibitors (e.g., sunitinib, lapatinib);
- histone deacetylase inhibitors (e.g., vorinostat);
- beta-2 adrenoceptor agonists (e.g., salmeterol, formoterol).

The use of TASIGNA is discouraged with drugs that can disrupt electrolyte levels, including, but not limited to, the following:

- loop, thiazide, and related diuretics;
- laxatives and enemas;
- amphotericin B;
- high dose corticosteroids.

The above lists of potentially interacting drugs are not comprehensive. Current information sources should be consulted for newly approved drugs that prolong the QT/QTc interval, inhibit metabolizing enzymes and/or transports, or cause electrolyte disturbances, as well as for older drugs for which these effects have recently been established.

Drug-Food Interactions

Food Effect

The bioavailability of nilotinib is increased by food. TASIGNA must not be taken in conjunction with food (see **DOSAGE AND ADMINISTRATION, WARNINGS AND PRECAUTIONS** and **ACTION AND CLINICAL PHARMACOLOGY**) and should be taken 2 hours after a meal. No food should be consumed for at least one hour after the dose is taken.

For patients who are unable to swallow capsules, the content of each capsule may be dispersed in one teaspoon of applesauce and should be taken immediately. Not more than one teaspoon of applesauce should be used. Yogurt was shown to result in a significant increase in bioavailability and therefore must be avoided and no food other than applesauce must be used (see **DOSAGE AND ADMINISTRATION**).

Products and juices containing grapefruit, star fruit, pomegranate, Seville oranges and other similar fruits that are known to inhibit CYP3A4 should be avoided at any time.

The absorption of TASIGNA is increased if it is taken with food, resulting in higher serum concentration (see **DOSAGE AND ADMINISTRATION, WARNINGS AND PRECAUTIONS and ACTION AND CLINICAL PHARMACOLOGY**).

Drug-Herb Interactions

St. John's Wort is a potent CYP3A4 inducer. Co-administration with TASIGNA may lead to increased TASIGNA metabolism, therefore decreased TASIGNA serum concentrations (see **Drug-Drug Interactions**).

Drug-Laboratory Interactions

Interactions with laboratory tests have not been established.

Drug-Lifestyle Interactions

Please refer to sections on **DOSAGE AND ADMINISTRATION** and **INTERACTIONS**.

Effects on ability to drive and use machines

No studies on the effects of nilotinib on the ability to drive and operate machines have been performed. Patients experiencing dizziness, visual impairment or other undesirable effects with a potential impact on the ability to safely drive or use machines should refrain from these activities as long as these undesirable effects persist (see **ADVERSE REACTIONS**).

Alcohol

No studies have been performed on the potential interaction between nilotinib and alcohol consumption. There is a single report of reduced efficacy of nilotinib in a patient concomitantly consuming alcohol.

Food

The bioavailability of nilotinib is increased by food. TASIGNA must not be taken in conjunction with food and should be taken 2 hours after a meal. No food should be consumed for at least one hour after the dose is taken. Grapefruit juice and other foods that are known to inhibit CYP3A4 should be avoided at any time.

DOSAGE AND ADMINISTRATION

Dosing Considerations

Pediatric patients (2 to < 18 years)

The safety and efficacy of TASIGNA in pediatric patients with Ph+ CML-CP from 2 to less than 18 years of age has been established (see **ADVERSE REACTIONS**, **CLINICAL PHARMACOLOGY**, and **CLINICAL TRIALS**). There is no experience in pediatric patients below 2 years of age or in pediatric patients with Ph+ CML-AP or blast crisis (BC).

Patients with renal impairment

Clinical studies have not been performed in patients with impaired renal function. Clinical studies have excluded patients with serum creatinine concentration >1.5 times the upper limit of the normal range.

TASIGNA and its metabolites are not renally excreted (See **Pharmacokinetics**).

Patients with hepatic impairment

Hepatic impairment has an effect on the pharmacokinetics of nilotinib in adults. Dose adjustment is not considered necessary in hepatically impaired patients. Patients with hepatic impairment should be treated with caution and careful clinical monitoring, including close monitoring of the QTc interval (see **WARNINGS AND PRECAUTIONS**).

Cardiac disorders

In clinical studies, newly diagnosed Ph+ CML-CP and imatinib-resistant or -intolerant Ph+ CML-CP and CML-AP patients with any of the following uncontrolled or significant cardiac disease were excluded: recent myocardial infarction, CHF, unstable angina, or clinically significant bradycardia. Imatinib-resistant or -intolerant Ph+ CML-CP and CML-AP patients with complete left bundle branch block and/or right bundle branch block, with left anterior hemiblock, or with bifascicular block were excluded from the study. Newly diagnosed Ph+ CML-CP patients with complete left bundle branch block were also excluded. ECG and cardiac enzyme monitoring were conducted in patients throughout the studies. Caution should be exercised in patients with relevant cardiac disorders (see **WARNINGS AND PRECAUTIONS**).

Patients at risk of tumour lysis syndrome

Due to possible occurrence of Tumour Lysis Syndrome (TLS) it is recommended to measure serum levels of creatinine, uric acid, phosphate, potassium, corrected calcium and LDH prior to the initiation of treatment with TASIGNA in order to assess the risk or presence of TLS and to monitor these parameters during the initial period of treatment with TASIGNA until a significant reduction of tumour cell burden has been achieved. Prophylaxis of TLS such as hydration and treatment of high uric acid levels in patients at risk and treatment of abnormalities subsequent to established TLS is required.

Method of administration

TASIGNA should be taken twice daily, at approximately 12 hour intervals and must not be taken with food. The capsules should be swallowed whole with water. No food should be consumed for at least 2 hours before the dose is taken and no additional food should be consumed for at least one hour after the dose is taken (see **WARNINGS AND PRECAUTIONS**, and **DRUG INTERACTIONS**).

For patients who are unable to swallow capsules, the content of each capsule may be dispersed in one teaspoon of applesauce and should be taken immediately. Not more than one teaspoon of applesauce should be used. Yogurt was shown to result in a significant increase in bioavailability and therefore must be avoided and no food other than applesauce must be used (see **ACTION AND CLINICAL PHARMACOLOGY**).

Recommended Dose and Dosage Adjustment

TASIGNA is available in three dosage strengths (50 mg, 150 mg and 200 mg).

Treatment with TASIGNA (nilotinib capsules) should be initiated by a physician experienced in the treatment of patients with CML.

In the adult clinical studies, TASIGNA was allowed to be given in combination with hematopoietic growth factors such as erythropoietin or G-CSF if clinically indicated. In the adult studies, TASIGNA was also allowed to be given with hydroxyurea (permitted during the first 28 days of treatment, up to 5 g/day for a maximum of 7 days) or anagrelide (permitted during the first 28 days of treatment) if clinically indicated.

Recommended Dose:

Adult patients with newly diagnosed Ph+ CML-CP

The recommended dose of TASIGNA is 300 mg (2x 150 mg capsules) orally twice daily (see **CLINICAL TRIALS**). Treatment should continue as long as the patient continues to benefit.

Ph+ CML-CP and CML-AP adult patients who are resistant to or intolerant to at least one prior therapy including imatinib:

The recommended dose of TASIGNA is 400 mg (2x 200 mg capsules) orally twice daily (see **CLINICAL TRIALS**). Treatment should continue as long as the patient does not show evidence of progression or unacceptable toxicity.

A baseline ECG is recommended prior to initiating therapy with TASIGNA and should be repeated after 7 days and as clinically indicated. Hypokalemia or hypomagnesemia must be corrected prior to TASIGNA administration and potassium and magnesium blood levels should be monitored periodically during therapy, particularly in patients at risk for these electrolyte abnormalities (see **WARNINGS AND PRECAUTIONS**).

Pediatric patients with newly diagnosed Ph+ CML-CP or resistant or intolerant Ph+ CML-CP

Dosing in pediatric patients is individualized and is based on body surface area (mg/m²). The recommended dose of TASIGNA is 230 mg/m² twice daily, rounded to the nearest 50 mg dose

(to a maximum single dose of 400 mg, see Table 6). This dose in pediatric patients had comparable pharmacokinetic exposure as the 400 mg twice daily dose in adults. Different strengths of TASIGNA hard capsules can be combined to attain the desired dose. Treatment should be continued as long as clinical benefit is observed or until unacceptable toxicity occurs. There is no experience with treatment of pediatric patients below 2 years of age.

Table 6 Pediatric dosing of Tasigna (230 mg/m² twice daily, maximum single dose of 400 mg)

Body Surface Area (BSA)	Total Daily Dose	Taken as
≤ 0.32 m ²	100 mg	one 50 mg capsule twice a day
0.33 – 0.54 m ²	200 mg	two 50 mg capsules twice a day
0.55 – 0.76 m ²	300 mg	one 150 mg capsule twice a day
0.77 – 0.97 m ²	400 mg	one 200 mg capsule twice a day
0.98 – 1.19 m ²	500 mg	one 50 mg and one 200 mg capsule twice a day
1.20 – 1.41 m ²	600 mg	two 150 mg capsules twice a day
1.42 – 1.63 m ²	700 mg	one 200 mg and one 150 mg capsule twice a day
≥1.64 m ²	800 mg	two 200 mg capsules twice a day

Dose Adjustments or Modifications:

Delay of treatment with TASIGNA in case of established TLS must be weighed in the individual patient against the risk of delayed control of tumour cell proliferation.

TASIGNA may need to be temporarily withheld and/or dose reduced for hematological toxicities (neutropenia, thrombocytopenia) that are not related to underlying leukemia (see Table 7 below).

Table 7 Dose Adjustments for Adult and Pediatric Patients with Neutropenia and Thrombocytopenia

Adult patients with: - Newly diagnosed Ph+ CML in chronic phase at 300 mg twice daily	ANC [#] < 1.0 x 10 ⁹ /L and/or platelet counts <50 x 10 ⁹ /L	1. Stop TASIGNA, and monitor blood counts. 2. Resume within 2 weeks at prior dose if ANC > 1.0x 10 ⁹ /L and/or platelets >50 x 10 ⁹ /L.
--	---	--

- Resistant or intolerant Ph+ CML in chronic phase or accelerated phase CML at 400 mg twice daily		3. If blood counts remain low for greater than 2 weeks, a dose reduction to 400 mg once daily may be required.
Pediatric patients with: - Newly diagnosed CML in chronic phase at 230 mg/m ² twice daily - Resistant or intolerant CML in chronic phase at 230 mg/m ² twice daily	ANC [#] <1 × 10 ⁹ /L and/or platelet counts <50 × 10 ⁹ /L	<ol style="list-style-type: none"> 1. Stop TASIGNA and monitor blood counts. 2. Resume within 2 weeks at prior dose if ANC >1.5 × 10⁹/L and/or platelets >75 × 10⁹/L. 3. If blood counts remain low for greater than 2 weeks, a dose reduction to 230 mg/m² once daily may be required. 4. If event occurs after dose reduction, consider discontinuing treatment.

[#]ANC= absolute neutrophil count

TASIGNA may need to be temporarily withheld and/or dose reduced for patients who experience QTc interval prolongation (see Table 8 below).

Table 8 Dose Adjustments for Adult and Pediatric Patients with QT prolongation

ECGs with a QTc > 480 msec	<ol style="list-style-type: none"> 1. Withhold TASIGNA, and perform an analysis of serum potassium and magnesium, and if below lower limit of normal, correct with supplements to within normal limits. Concomitant medication usage must be reviewed. 2. Resume TASIGNA within 2 weeks at prior dose if QTcF returns to < 450 msec and to within 20 msec of baseline. 3. If QTcF is between 450 msec and 480 msec after 2 weeks reduce the dose to 400 mg once daily in adults and 230mg/m² once daily in pediatric patients. 4. If, following dose-reduction to 400 mg once daily in adults and 230mg/m² once daily in pediatric patients, QTcF returns to >480 msec, TASIGNA should be discontinued. 5. An ECG should be repeated approximately 7 days after any dose adjustment.
----------------------------	---

See Table 9 below for dose adjustments for elevations of lipase, amylase, bilirubin, and/or hepatic transaminases (see **ADVERSE REACTIONS**).

Table 9 Dose Adjustments for Adult and Pediatric Patients with Selected Non-hematologic Laboratory Abnormalities

Elevated serum lipase or amylase \geq Grade 3	<p>Adult Patients:</p> <ol style="list-style-type: none"> 1. Withhold TASIGNA, and monitor serum lipase or amylase 2. Resume treatment at 400 mg once daily if serum lipase or amylase return to \leq Grade 1¹
	<p>Pediatric Patients:</p> <ol style="list-style-type: none"> 1. Tassigna must be interrupted until the event returns to less than or equal to Grade 1. 2. Resume treatment at 230mg/m² once daily if prior dose was 230mg/m² twice daily; if prior dose was 230 mg/m² once daily, treatment should be discontinued.
Elevated Total bilirubin \geq Grade 3 in adult patients and greater than or equal to Grade 2 in pediatric patients	<p>Adult Patients</p> <ol style="list-style-type: none"> 1. Withhold TASIGNA, and monitor total bilirubin 2. Resume treatment at 400 mg once daily if total bilirubin return to \leq Grade 1 3. Total bilirubin levels should be tested frequently or as clinically indicated
	<p>Pediatric Patients:</p> <ol style="list-style-type: none"> 1. Tassigna must be interrupted until the event returns to less than or equal to Grade 1. 2. Resume treatment at 230mg/m² once daily if prior dose was 230mg/m² twice daily; if prior dose was 230mg/m² once daily, and recovery to less than or equal to Grade 1 takes longer than 28 days, treatment should be discontinued.

Elevated hepatic transaminases \geq Grade 3	<p>Adult Patients:</p> <ol style="list-style-type: none"> 1. Withhold TASIGNA, and monitor hepatic transaminases 2. Resume treatment at 400 mg once daily if hepatic transaminases return to \leq Grade 1 3. Hepatic transaminases levels should be tested frequently or as clinically indicated
	<p>Pediatric Patients:</p> <ol style="list-style-type: none"> 1. Tasigna must be interrupted until the event returns to less than or equal to Grade 1. 2. Resume treatment at 230mg/m² once daily if prior dose was 230mg/m² twice daily; if prior dose was 230mg/m² once daily, and recovery to less than or equal to Grade 1 takes longer than 28 days, treatment should be discontinued.

¹ Serum lipase levels should be tested frequently or as clinically indicated

Serum lipase elevations were observed in adult patients. Few of these elevations were associated with clinical symptoms such as abdominal pain or a diagnosis of pancreatitis. There were 5 cases (1.1%) of pancreatitis reported in imatinib-resistant or-intolerant Ph+ CML-CP and CML-AP patients (N= 458). In adult newly diagnosed Ph+ CML-CP 5 (1.8%) and 8 (2.9%) cases of pancreatitis were reported in patients receiving TASIGNA 300 mg twice daily (N=279) and 400 mg twice daily (N=277), respectively. In case lipase elevations are accompanied by abdominal symptoms, doses should be interrupted and appropriate diagnostics should be considered in order to exclude pancreatitis (see **WARNINGS AND PRECAUTIONS**).

If clinically significant moderate or severe non-hematologic toxicity develops (including medically severe fluid retention), see Table 10 for dose adjustments (**See ADVERSE REACTIONS section**).

Table 10 Dose Adjustments for Adult and Pediatric Patients with Other Non-hematologic Toxicities

Other clinically moderate or severe non-hematologic toxicity (including fluid retention)	<p>Adult patients:</p> <ol style="list-style-type: none"> 1. Withhold Tasigna until toxicity has resolved. 2. Resume treatment at 400 mg once daily if previous dose was 300 mg twice daily in adult patients newly diagnosed with CML-CP or 400 mg twice daily in adult patients with resistant or intolerant CML-CP and CML-AP. 3. If the prior dose was 400 mg once daily in adult patients, treatment should be discontinued. 4. If clinically appropriate, re-escalation of the dose to 300 mg (newly diagnosed Ph+ CML-CP) or 400 mg (resistant or intolerant Ph+ CML-CP and CML-AP) twice daily should be considered.
	<p>Pediatric patients:</p> <ol style="list-style-type: none"> 1. Tasigna must be interrupted until toxicity has resolved. 2. Resume treatment at 230mg/m² once daily if previous dose was 230mg/m² twice daily; if prior dose was 230mg/m² once daily, treatment should be discontinued. 3. If clinically appropriate, re-escalation of the dose to 230mg/m² twice daily should be considered.

Discontinuation of treatment after a sustained molecular response (MR4.5) on TASIGNA:

Eligibility for Discontinuation of Treatment

Adult Ph+ CML-CP patients with typical *BCR-ABL* transcripts who have been taking TASIGNA for a minimum of 3 years and have achieved a sustained molecular response (MR4.5, corresponding to $BCR-ABL/ABL \leq 0.0032\%$ IS) may be eligible for treatment discontinuation (see **CLINICAL TRIALS**). Discontinuation of TASIGNA treatment in pediatric patients to attempt treatment free remission has not been assessed.

Adult patients with typical *BCR-ABL* transcripts (i.e., 13a2/b2a2 or e14a2/b3a2) who achieve the sustained MR4.5 criteria are eligible for discontinuation of TASIGNA treatment. Patients must continue to be monitored for possible loss of molecular remission after treatment discontinuation using a quantitative diagnostic test validated with a sensitivity of at least MR4.5 ($BCR-ABL/ABL \leq 0.0032\%$ IS).

Discontinuation of treatment may be considered in adult patients with newly diagnosed Ph+ CML-CP who have:

- been treated with TASIGNA for at least 3 years
- maintained a molecular response of at least MR4.0 (corresponding to $BCR-ABL/ABL \leq 0.01\%$ IS) for at least one year prior to discontinuation of therapy

- achieved an MR4.5 for the last assessment taken immediately prior to discontinuation of therapy
- been confirmed to express the typical *BCR-ABL* transcripts (e13a2/b2a2 or e14a2/b3a2)
- no history of accelerated phase or blast crisis
- no history of prior attempts of treatment-free remission discontinuation that resulted in relapse.

Discontinuation of treatment may be considered in patients with Ph+ CML-CP that are resistant or intolerant to prior treatment that included imatinib who have achieved a sustained molecular response (MR4.5) on TASIGNA who have:

- been treated with TASIGNA for a minimum of 3 years
- been treated with imatinib only prior to treatment with TASIGNA
- achieved a molecular response of MR4.5 (corresponding to $BCR-ABL/ABL \leq 0.0032\%$ IS)
- sustained MR4.5 for a minimum of one year immediately prior to discontinuation of therapy
- been confirmed to express the typical *BCR-ABL* transcripts (e13a2/b2a2 or e14a2/b3a2)
- no history of accelerated phase or blast crisis
- no history of prior attempts of treatment-free remission discontinuation that resulted in relapse.

Monitor *BCR-ABL* transcript levels and complete blood count with differential in patients who have discontinued TASIGNA therapy monthly for one year, then every 6 weeks for the second year, and every 12 weeks thereafter.

Upon loss of MR4.0 (corresponding to $BCR-ABL/ABL \leq 0.01\%$ IS) during the treatment-free phase, monitor *BCR-ABL* transcript levels every 2 weeks until *BCR-ABL* levels remain lower than major molecular response (MMR, corresponding to MR3.0 or $BCR-ABL/ABL \leq 0.1\%$ IS) for 4 consecutive measurements. The patient can then proceed to the original monitoring schedule.

Re-initiation of treatment in patients who lose molecular response after discontinuation of therapy with TASIGNA:

- Newly diagnosed patients who lose MMR must reinitiate treatment within 4 weeks at the dose level prior to discontinuation of therapy. Patients who reinitiate TASIGNA therapy should have their *BCR-ABL* transcript levels monitored monthly until MMR is re-established and every 12 weeks thereafter.
- Ph+ CML-CP patients resistant or intolerant to prior treatment that included imatinib with confirmed loss of MR4.0 (2 consecutive measures separated by at least 4 weeks showing loss of MR4.0) or loss of MMR must reinitiate treatment within 4 weeks at the dose level prior to

discontinuation of therapy. Patients who reinitiate TASIGNA therapy should have their *BCR-ABL* transcript levels monitored monthly until previous MMR or MR4.0 is re-established and every 12 weeks thereafter.

Missed Dose

If a dose is missed, the patient should not take an additional dose, but take the next scheduled usual prescribed dose.

OVERDOSAGE

Isolated reports of intentional overdose with nilotinib were reported, where an unspecified number of TASIGNA capsules were ingested in combination with alcohol and other drugs. Events included neutropenia, vomiting and drowsiness. No ECG changes or hepatotoxicity were reported. Outcomes were reported as recovered. One case of accidental overdose in a patient who took a second dose of TASIGNA 400mg shortly after having ingested a first dose of 400 mg. Approximately 8 hours after ingestion, the patient reported feeling weak, abdominal pain, tachycardia and epistaxis.

In the event of overdose, the patient should be observed and appropriate supportive treatment given.

For management of a suspected drug overdose, contact your regional Poison Control Centre.

ACTION AND CLINICAL PHARMACOLOGY

Mechanism of Action

Pharmacotherapeutic group: Antineoplastic agents - Protein-tyrosine kinase inhibitor ATC code: L01XE08.

TASIGNA is a potent and selective inhibitor of the ABL tyrosine kinase activity of the BCR-ABL oncoprotein both in cell lines and in primary Philadelphia-chromosome positive leukemia cells. The drug binds strongly within the ATP-binding site in such a manner that it is a potent inhibitor of wild-type BCR-ABL and maintains activity against 32/33 imatinib-resistant mutant forms of BCR-ABL with the T315I mutant being the exception. As a consequence of this biochemical activity, nilotinib selectively inhibits the proliferation and induces apoptosis in cell lines and in primary Philadelphia-chromosome positive leukemia cells from CML patients. In murine models of CML, as a single agent nilotinib reduces tumour burden and prolongs survival following oral administration.

TASIGNA has also little or no effect against the majority of other protein kinases examined, except for PDGFR α , PDGFR β , Kit CSF-1R, DDR-1 and DDR-2 and Ephrin receptor kinases which it inhibits at concentrations within the range achieved following oral administration at therapeutic doses recommended for the treatment of CML (see Table 11).

Table 11 Kinase Profile of nilotinib (Phosphorylation IC₅₀ nM)

BCR-ABL	PDGFR	KIT
20	69	210

Pharmacodynamics

A dose response in the Phase IA component of Study 2101 was explored using the following initial dose cohorts based on daily exposure to nilotinib. The twice daily doses were associated with higher exposures as compared to the once daily doses (See Table 12 below).

Table 12 Dose and corresponding exposure in all adult patients or CML-AP patients

Group	Initial dose (mg)	Regimen	Exposure	Steady-state (day 15) AUC _{0-24h} (ng·h/mL)	
				All patients ^{a)}	CML-AP patients ^{b)}
1	50-200	once daily	Low	6880 (4750)	6610 (2350-14600)
2	400-1200	once daily	Middle	26000 (13800)	24900 (5770-65900)
3	400	twice daily	High	36000 (11800)	35200 (14600-61000)
4	600	twice daily	High	32800 (13800)	28900 (16000-61500)

^{a)} Mean (SD) of dose group

^{b)} Median (range) of dose group

Pharmacokinetics - Adults**Table 13 Summary of nilotinib's pharmacokinetic parameters in serum plasma after a single 400 mg oral dose in healthy adult male volunteers (n=4)¹**

t _{max}	C _{max}	t _½ (h)	AUC _{0-∞}	Clearance (CL/F)	Volume of distribution (V _z /F)
3.5 hours	599 ng/mL	17 hours	20700 ng.h/mL	29.1 L/hour	579 L

¹ values are median for t_{max} and mean for all others

Absorption:

Peak concentrations of nilotinib are reached 3 hours after oral administration. Nilotinib absorption following oral administration was approximately 30%. The absolute bioavailability of nilotinib has not been determined.

In healthy volunteers, C_{max} and area under the serum concentration-time curve (AUC) of nilotinib are increased by 112% and 82%, respectively compared to fasting conditions when TASIGNA is given with food. Administration of TASIGNA 30 minutes or 2 hours after food increased bioavailability of nilotinib by 29% or 15%, respectively (see **DOSAGE AND ADMINISTRATION**, and **DRUG INTERACTIONS**). Nilotinib absorption (relative bioavailability) was reduced by approximately 48% and 22% in patients with total gastrectomy

and partial gastrectomy, respectively. Mean steady state trough concentration of nilotinib in patients with total gastrectomy was 599 ng/mL vs. 1035 ng/mL in patients without prior GI resection.

In healthy subjects, single dose administration of 400 mg of nilotinib, using 2 capsules of 200 mg whereby the content of each capsule was dispersed in one teaspoon of applesauce, was shown to be bioequivalent with a single dose administration of 2 intact capsules of 200 mg.

Distribution:

Blood-to-plasma ratio of nilotinib is 0.68. Plasma protein binding is approximately 98% on the basis of *in vitro* experiments.

Metabolism:

Main metabolic pathways identified in healthy subjects are oxidation and hydroxylation. Nilotinib is the main circulating component in the serum. None of the metabolites contribute significantly to the pharmacological activity of nilotinib.

Excretion:

After a single dose of radiolabelled nilotinib in healthy subjects, greater than 90% of the dose was eliminated within 7 days mainly in feces. Parent drug accounted for 69% of the dose. The apparent elimination half-life estimated from the multiple dose PK with daily dosing was approximately 17 hours. Inter-patient variability in nilotinib PK was moderate to high.

Linearity / non-linearity

Steady-state nilotinib exposure was dose-dependent with less than dose-proportional increases in systemic exposure at dose levels higher than 400 mg given as once daily dosing. Daily systemic exposure to nilotinib of 400 mg twice-daily dosing at steady state was 35% higher than with 800 mg once-daily dosing. Systemic exposure (AUC) of nilotinib at steady state at a dose level of 400 mg twice daily was approximately 13.4% higher than with 300 mg twice daily, based on a full pharmacokinetic profile comparison. The average nilotinib trough and peak concentrations over 12 months, obtained from 275 patients in the nilotinib 300 mg twice daily and 267 patients in the nilotinib 400 mg twice daily, were approximately 15.7% and 14.8% higher following 400 mg twice daily dosing compared to 300 mg twice daily. There was no relevant increase in exposure to nilotinib when the dose was increased from 400 mg twice-daily to 600 mg twice-daily.

Steady-state conditions were essentially achieved by day 8. An increase in serum exposure to nilotinib between the first dose and steady state was approximately 2-fold for daily dosing and 3.8-fold for twice-daily dosing.

Special Populations and Conditions:

Pediatric pharmacokinetics: Following administration of nilotinib in pediatric patients at 230 mg/m² twice daily, rounded to the nearest 50 mg dose (to a maximum single dose of 400 mg), steady-state exposure and clearance of nilotinib were found to be similar (within 2-fold) to adult patients treated with 400 mg twice daily. Overall steady-state exposure of nilotinib as measured by C_{trough} are similar between the two age groups 2 to < 12 years and 12 to 18 years (mean

Ctrough ranged from 1540 ng/mL to 1910 ng/mL for the younger group (2 to <12 years) compared to a range of 1200 ng/mL to 1640 ng/mL for the older group (12 to 18 years).

Furthermore, individual predictions from the PopPK study were consistent with observed data, showing similarity across age groups. Medians of individual predictions of BSA-normalized clearances (L/h/m²) in the 2 to < 12 y, 12 to < 18 y, and ≥18 y age groups were 13.8, 13.1, and 13.0 L/h/m², respectively. Medians of individual predictions of AUCss in the 2 to < 12 y, 12 to < 18 y, and ≥18 y age groups were 16600, 17300, 15300 h·ng/mL, respectively.

Effect of age or gender on PK: Age, body weight, or ethnic origin do not significantly affect the pharmacokinetics of nilotinib in adult patients, whereas there is an effect of gender, with exposure to nilotinib in female patients being approximately 20% greater than in male patients. The PK exposure in pediatric trials was based prospectively on dosing by body surface area (BSA) with a dose of 230 mg/m² twice daily rounded to the nearest multiple of 50 mg not to exceed 400 mg. The effects of body surface area played the major role for accounting for differences in pharmacokinetics between pediatrics (ages 2 to <18 y) and adults, and thus justifying a mg/m² dosing in pediatrics. This dose in children had comparable PK exposure as the 400 mg twice daily dose in adults.

Pharmacogenomics: TASIGNA can lead to elevated bilirubin levels. A pharmacogenetic analysis of 101 imatinib-resistant or -intolerant Ph+ CML-CP and CML-AP patients was conducted to evaluate the polymorphisms of UGT1A1 and its potential association with hyperbilirubinemia during TASIGNA treatment. In this study, the (TA)7/(TA)7 genotype was associated with a statistically significant increase in the risk of hyperbilirubinemia relative to the (TA)6/(TA)6 and (TA)6/(TA)7 genotypes. The largest increases in bilirubin were observed in patients with the (TA)7/(TA)7 genotype. Caution is recommended in patients with (TA)7/(TA)7 genotype. (see **WARNINGS AND PRECAUTIONS** and **DOSAGE AND ADMINISTRATION**).

Patients with hepatic impairment: Hepatic impairment has an effect on the pharmacokinetics of TASIGNA. Single dose administration of TASIGNA 200 mg resulted in increases in AUC of 35%, 35% and 56% in subjects with mild, moderate and severe hepatic impairment, respectively, compared to a control group of subjects with normal hepatic function. The steady-state C_{max} of TASIGNA will likely to be increased by up to approximately 29% in subjects with hepatic impairment (see **DOSAGE AND ADMINISTRATION**).

STORAGE AND STABILITY

Store at room temperature (15-30°C).

Store in the original package.

TASIGNA must be kept out of reach and sight of children.

SPECIAL HANDLING INSTRUCTIONS

No special requirements.

DOSAGE FORMS, COMPOSITION AND PACKAGING

TASIGNA (nilotinib capsules) 50 mg Hard Capsules:

Each capsule contains 50 mg nilotinib base (as hydrochloride monohydrate).

White to yellowish powder in hard gelatin capsule with red opaque cap and light yellow opaque body, size 4 with black radial imprint “NVR/ABL” on cap.

Non- medicinal Ingredients:

Capsule content: Colloidal silicon, anhydrous; Crospovidone; Lactose monohydrate; Poloxamer; Magnesium stearate.

Capsule shell: Gelatin; Titanium dioxide (E171); Iron oxide, red (E172); Iron oxide, yellow (E172).

Printing ink: Shellac; Iron oxide, black (E172); Propylene glycol; Ammonium hydroxide

TASIGNA (nilotinib capsules) 150 mg Hard Capsules:

Each capsule contains 150 mg nilotinib base (as hydrochloride monohydrate).

White to yellowish powder in red opaque hard gelatin capsules, size 1 with black axial imprint “NVR/BCR”.

Non- medicinal Ingredients:

Capsule content: Colloidal silicon, anhydrous; Crospovidone; Lactose monohydrate; Poloxamer 188; Magnesium stearate.

Capsule shell: Gelatin; Titanium dioxide (E171); Iron oxide, red (E172), Iron oxide, yellow (E 172).

Printing ink: black (E172) iron oxide.

TASIGNA (nilotinib capsules) 200 mg Hard Capsules:

Each capsule contains 200 mg nilotinib base (as hydrochloride monohydrate).

White to yellowish powder in light yellow opaque hard gelatin capsules, size 0 with red axial imprint “NVR/TKI”.

Non- medicinal Ingredients:

Capsule content: Colloidal silicon anhydrous; Crospovidone; Lactose monohydrate; Poloxamer 188; Magnesium stearate.

Capsule shell: Gelatin; Titanium dioxide; Iron oxide, yellow.

Printing ink: includes red iron oxide.

Availability of Dosage Forms:
TASIGNA (nilotinib capsules)

50 mg Capsules are supplied in blister packs (5strips of 8 blisters/card, 3 cards/carton).

150 mg Capsules are supplied in blister packs (7 strips of 4 blisters/card, 4 cards/carton).

200 mg Capsules are supplied in blister packs (7 strips of 4 blisters/card, 4 cards/carton).

PART II: SCIENTIFIC INFORMATION

PHARMACEUTICAL INFORMATION

Drug Substance

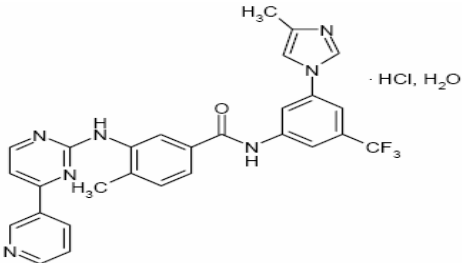
Common name:	Nilotinib hydrochloride monohydrate	
Chemical name:	4-Methyl-N-[3-(4-methyl-1H-imidazol-1-yl)-5-(trifluoromethyl)phenyl]-3-[[4-(3-pyridinyl)-2-pyrimidinyl]amino]-benzamide, monohydrochloride, monohydrate	
	4-Methyl-N-[3-(4-methyl-1H-imidazol-1-yl)-5-(trifluoromethyl)phenyl]-3-[(4-pyridin-3-yl)pyrimidin-2-yl]amino]benzamide hydrochloride hydrate	
Molecular formula:	Salt form as monohydrate:	$C_{28}H_{22}F_3N_7O \cdot HCl \cdot H_2O$
	Salt form on anhydrous basis:	$C_{28}H_{22}F_3N_7O \cdot HCl$
	Nilotinib base:	$C_{28}H_{22}F_3N_7O$
Molecular mass:	Salt form as monohydrate:	583.99
	Salt form on anhydrous basis:	565.98
	Nilotinib base:	529.52
Structural formula:		

Physicochemical properties:

Physical Description:	White to slightly yellowish or slightly greenish yellowish powder.
Solubility:	Solubility of nilotinib hydrochloride monohydrate in aqueous solutions strongly decreases with increasing pH, and that nilotinib hydrochloride monohydrate is practically insoluble in buffer solutions of pH 4.5 and higher pH values. Nilotinib hydrochloride monohydrate is very soluble

in dimethyl sulfoxide, sparingly soluble in ethanol and methanol, very slightly soluble in acetonitrile and n-octanol.

pH: The pH value of a 0.02% solution of nilotinib hydrochloride monohydrate in water/ethanol 50:50 (V/V) was found to be 4.3. The pH value of a 0.1% suspension of nilotinib hydrochloride monohydrate in water was determined to be 5.3.

pKa: $pK_{a1} = 2.1$, and
 $pK_{a2} = 5.4$.

Partition Coefficient: The distribution coefficient for nilotinib hydrochloride monohydrate in n-octanol/0.1N HCl buffer at $37.0 \pm 0.5^\circ\text{C}$ was determined to be 0.08.

Melting point: Nilotinib hydrochloride monohydrate may undergo dehydration prior to melting, therefore no range can be defined.

CLINICAL TRIALS

Newly diagnosed Ph+ CML-CP (adults)

Study demographics and trial design

The clinical efficacy of nilotinib in newly diagnosed Ph+ CML-CP adult patients, has been demonstrated based on the Phase III Study (A2303). The design of the study is illustrated in Figure 1.

Figure 1.

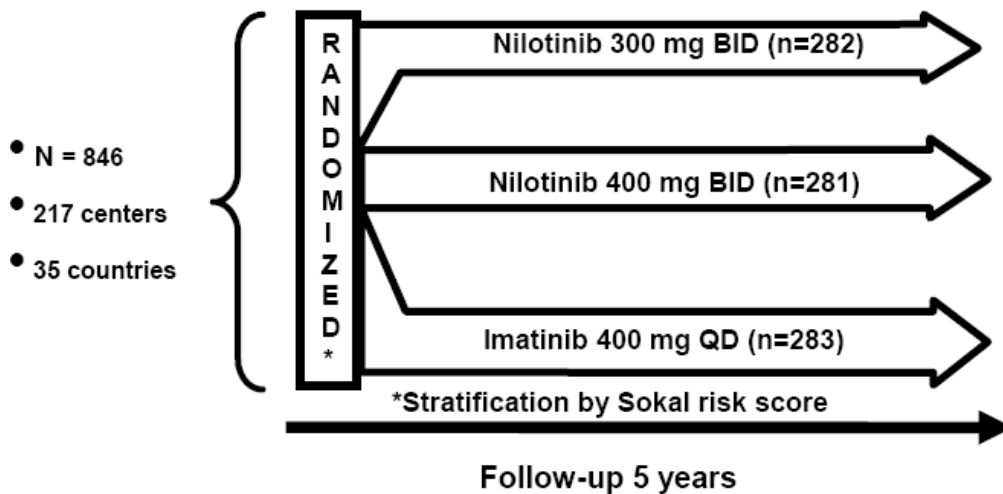

Table 14 Summary of adult patient demographics for clinical trials (Newly diagnosed Ph+ CML-CP patients exposed to study drug)

Study #	Trial design	Dosage, route of administration and duration	Study subjects (n=number)	Mean age (Range)	Gender
A2303	Open label, multicenter, randomized Phase III study was conducted to determine the efficacy of TASIGNA versus GLEEVEC in adult patients with cytogenetically confirmed newly diagnosed Ph+ CML-CP.	<p>nilotinib and imatinib were administered orally:</p> <p>imatinib 400 mg once daily</p> <p>nilotinib 300 mg twice daily</p> <p>nilotinib 400 mg twice daily</p> <p>Median time on treatment was approximately 60 months in all three treatment groups.</p>	<p>Total number of patients randomized = 846</p> <p>imatinib 400 mg once daily (n=283)</p> <p>nilotinib 300 mg twice daily (n= 282)</p> <p>nilotinib 400 mg twice daily (n=281)</p>	<p>imatinib 400 mg once daily 12.4% ≥ 65 years of age Mean: 47(18-80)</p> <p>nilotinib 300 mg twice daily 12.8% ≥ 65 years of age Mean: 47 (18-85)</p> <p>nilotinib 400 mg twice daily 10.0% ≥ 65 years of age in Mean: 47 (18-81)</p>	<p>imatinib 400 mg once daily M=55.8% F=44.2%</p> <p>nilotinib 300 mg twice daily M=56.0% F=44.0%</p> <p>nilotinib 400 mg twice daily M=62.3% F=37.7%</p>

An open label, multicenter, randomized Phase III study (A2303) was conducted to determine the efficacy of TASIGNA versus imatinib in adult patients with cytogenetically confirmed newly diagnosed Ph+CML-CP. Patients were within six months of diagnosis and were previously untreated for CML-CP, except for hydroxyurea and/or anagrelide (See Table 15). In addition, patients were stratified according to Sokal risk score at time of diagnosis.

Baseline characteristics were well balanced between the groups (Table 14). There were slightly more male than female patients in all groups. More than 60% of all patients were Caucasian, and 25% were Asian. Table 15 displays the disease history characteristics.

The primary data analysis time point was when all 846 patients completed 12 months of treatment (or discontinued earlier). Subsequent analyses reflect when patients completed 24, 36, 48 and 60 months of treatment (or discontinued earlier). The median time on treatment is approximately 60 months in all three treatment groups.

The median actual dose intensity was 400 mg/day in the imatinib group, 593 mg/day in the nilotinib 300 mg twice daily group. This study is on-going. Table 16 displays the duration of exposure with TASIGNA.

Table 15 CML Disease History Characteristics

	TASIGNA 300 mg twice daily N=282	Imatinib 400 mg once daily N=283
Median time since diagnosis of CML in days (range)	31.0 (0-182)	28.0 (1-183)
Hydroxyurea	216 (76.6%)	201 (71.0%)
Anagrelide	6 (2.1%)	4 (1.4%)

Table 16 Duration of Exposure with TASIGNA

	TASIGNA 300 mg twice daily N=279	Imatinib 400 mg once daily N=277
Median duration of therapy in months (95%CI)	60.02 (59.20-60.42)	58.69 (52.21-59.99)

Study Results:**Primary Efficacy Endpoint: Major Molecular Response (MMR)**

The primary efficacy variable was MMR at 12 months after the start of study medication. MMR was defined as $\leq 0.1\%$ BCR-ABL/ABL % by international scale measured by Real-Time Quantitative PCR (RQ-PCR), which corresponds to a ≥ 3 log reduction of BCR-ABL transcript from standardized baseline.

The primary efficacy endpoint, MMR rate at 12 months was statistically significantly superior in the nilotinib 300 mg twice daily group compared to the imatinib 400 mg once daily group (44.3% vs. 22.3%, $p < 0.0001$) (Table 17).

At the nilotinib recommended dose of 300 mg twice daily, the rates of MMR at 3, 6, 9 and 12 months was 8.9%, 33.0%, 43.3% and 44.3%, respectively. In the imatinib 400 mg once daily group, the rates of MMR at 3, 6, 9 and 12 months was 0.7%, 12.0%, 18.0% and 22.3%.

The MMR rates at 12, 24, 36, 48, and 60 months is presented in Table 17.

Table 17 MMR rate

	TASIGNA 300 mg twice daily N=282* n (%)	Imatinib 400 mg once daily N=283* n (%)
MMR at 12 months² 95% CI for response	125(44.3) ¹ [38.4, 50.3]	63(22.3) [17.6, 27.6]
MMR at 24 months² 95% CI for response	174 (61.7) ¹ [55.8, 67.4]	106 (37.5) [31.8, 43.4]
MMR at 36 months² 95% CI for response	165 (58.5) ¹ [52.5, 64.3]	109 (38.5) [32.8, 44.5]
MMR at 48 months² 95% CI for response	169 (59.9) ¹ [54.0,65.7]	124 (43.8) [38.0,49.8]
MMR at 60 months² 95% CI for response	177 (62.8) [56.8,68.4]	139 (49.1) [43.2,55.1]

* Denominator for this analysis (N) includes all randomized patients, whether evaluable or not evaluable for MMR

¹ CMH test p-value for response rate (vs. Imatinib 400 mg) <0.0001

² Only patients who were in MMR at a specific time point are included as responders for that time point. Other randomized patients, whether evaluable or not at that time point, are conservatively considered as not MMR:

- A total of 129 (15.2%) of all patients were not evaluable for MMR at 12 months (40 in the nilotinib 300 mg BID group, 41 in the nilotinib 400 mg BID group and 48 in the imatinib group) due to missing/not evaluable PCR assessments (n=3), atypical transcripts at baseline (n=8), or discontinuation prior to the 12-month time point (n=118).
- A total of 211 (24.9%) of all patients were not evaluable for MMR at 24 months (68 in the nilotinib 300 mg BID group, 61 in the nilotinib 400 mg BID group and 82 in the imatinib group) due to missing/ not evaluable PCR assessments (n=13), atypical transcripts at baseline (n=8), or discontinuation prior to the 24-month time point (n=190).
- A total of 199 (35.2%) of all patients were not evaluable for MMR at 36 months (87 in the nilotinib 300 mg BID group and 112 in the imatinib group) due to missing/ not evaluable PCR assessments (n=17), atypical transcripts at baseline (n=7), or discontinuation prior to the 36-month time point (n=175).
- A total of 305 (36.1%) of all patients were not evaluable for MMR at 48 months (98 in the nilotinib 300 mg BID group, 88 in the nilotinib 400 mg BID group and 119 in the imatinib group) due to missing/ not evaluable PCR assessments (n=18), atypical transcripts at baseline (n=8), or discontinuation prior to the 48-month time point (n=279).
- A total of 322 (38.1%) of all patients were not evaluable for MMR at 60 months (99 in the nilotinib 300mg BID group, 93 in the nilotinib 400 mg BID group and 130 in the imatinib group) due to missing/ not evaluable PCR assessments (n=9), atypical transcripts at baseline (n=8), or discontinuation prior to the 60-month time point (n=305).

MMR rates by different time points (including patients who achieved MMR at or before those time points as responders) are presented in the cumulative incidence of MMR (Figure 2).

Figure 2 Cumulative Incidence of MMR

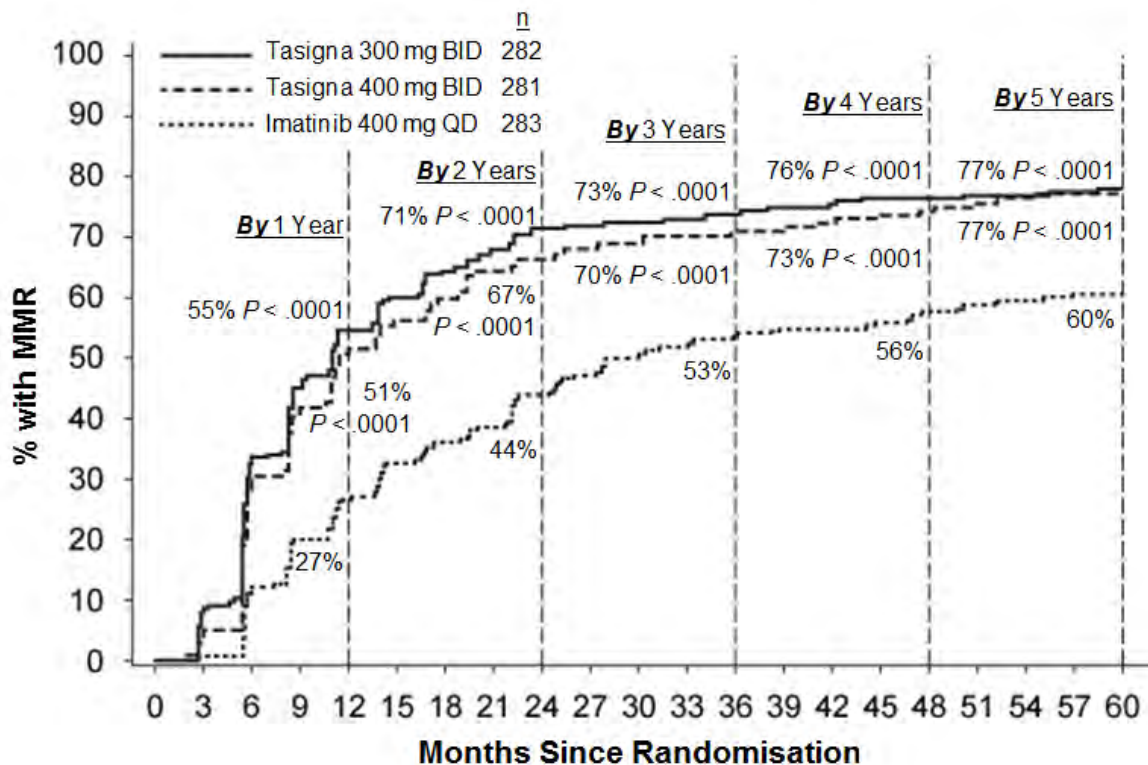

For all Sokal risk groups, the MMR rates at all timepoints remained consistently higher in the 300 mg twice daily nilotinib group than in the imatinib group.

In an exploratory analysis, 91% (234/258) of patients on nilotinib 300 mg twice daily achieved BCR-ABL levels $\leq 10\%$ at 3 months of treatment compared to 67% (176/264) of patients on imatinib 400 mg once daily.

Based on the Kaplan-Meier analyses of time to first MMR among all patients, the probability of achieving MMR at different time points was higher in the nilotinib group compared to the imatinib group (HR=2.20 and stratified log-rank $p < 0.0001$ between nilotinib 300 mg twice daily and imatinib).

Table 18 Best overall BCR-ABL ratio rates (by 60 months cut-off) – Study CAMN107A2303 (FAS)

	TASIGNA 300 mg twice daily N=282	Imatinib 400 mg once daily N=283
BCR-ABL ratio categories¹		
≤0.0032%	156 (55.3%)	92 (32.5%)
>0.0032% - ≤0.01%	31 (11%)	28 (9.9%)
>0.01 - ≤0.1 %	31 (11%)	53 (18.7%)
>0.1 - ≤1 %	28 (9.9%)	43 (15.2%)
>1 - ≤10 %	15 (5.3%)	26 (9.2%)
>10 %	12 (4.3%)	32 (11.3%)

¹Molecular response of >0.01 - ≤0.1 %, >0.0032-≤ 0.01% and ≤ 0.0032% by International Scale (IS) corresponds to a ≥3 log to <4 log reduction; a ≥ 4 log to <4.5 log reduction and ≥ 4.5 log reduction, respectively, of BCR-ABL transcripts from a standardized baseline.

Patients categorized according to their best overall BCR-ABL ratio achieved are summarized in Table 18 above.

The proportions of patients who had a molecular response of ≤ 0.01% and ≤ 0.0032% by International Scale (IS) at different time-points is presented in Table 19.

Table 19 Proportions of patients who had molecular response of ≤ 0.01% (4 log reduction and ≤ 0.0032% (4.5 log reduction)

	TASIGNA 300 mg twice daily N=282 (%)		Imatinib 400 mg once daily N=283 (%)	
	≤ 0.01%	≤ 0.0032%	≤ 0.01%	≤ 0.0032%
At 12 months	11.7	4.6	3.9	0.4
At 24 months	24.5	12.4	10.2	2.8
At 36 months	29.4	13.8	14.1	8.1
At 48 months	33.0	16.3	19.8	10.2
At 60 months	47.9	32.3	31.1	19.8

Duration of MMR

Based on Kaplan-Meier estimates of the duration of first MMR, the proportions of patients who achieved MMR and were maintaining response for 60 months among patients who achieved MMR were 93.4% (95% CI: 89.9% to 96.9%) in the nilotinib 300 mg twice daily group, and 89.1% (95% CI: 84.2% to 94.0%) in the imatinib 400 mg once daily group.

Secondary Efficacy Endpoint: Complete Cytogenetic Response (CCyR)

CCyR was defined as 0% Ph+ metaphases in the bone marrow based on a minimum of 20 metaphases evaluated. CCyR rate by 12 months (includes patients who achieved CCyR at or before the 12 month time point as responders) was statistically higher for the nilotinib 300 mg twice daily group compared to imatinib 400 mg once daily group, Table 20.

CCyR rate by 24 months (includes patients who achieved CCyR at or before the 24 month time point as responders) was statistically higher for the nilotinib 300 mg twice daily group compared to imatinib 400 mg once daily group (Table 20).

Table 20 Rate of Complete Cytogenetic Response (CCyR)

	TASIGNA 300 mg twice daily N=282 n (%)	Imatinib 400 mg once daily N=283 n (%)
By 12 months		
Complete Cytogenetic Response	226 (80.1)	184 (65.0)
95% CI for response	[75.0,84.6]	[59.2,70.6]
CMH test p-value for response rate (vs. imatinib 400 mg)	<0.0001	
By 24 months		
Complete Cytogenetic Response	245 (86.9)	218 (77.0)
95% CI for response	[82.4, 90.6]	[71.7, 81.8]
CMH test p-value for response rate (vs. Imatinib 400 mg)	0.0018	

CMH: Cochran-Mantel-Haenszel

Cytogenetic assessments after 24 months follow-up were not required

Duration of CCyR

Based on Kaplan-Meier estimates, the proportions of patients were maintaining response for 60 months among patients who achieved CCyR were 99.1% (95% CI: 97.9% to 100%) in the nilotinib 300 mg twice daily group, and 97.0% (95% CI: 94.7% to 99.4%) in the imatinib 400 mg once daily group.

Secondary Efficacy Endpoint: Progression to accelerated phase and blast crisis (AP/BC) on study

Progression “on study” refers to the first documented disease progression to AP/BC or CML-related death that occurred at any time after randomization, up to a 60 month post-treatment follow-up cut-off. Patients receiving nilotinib 300 mg twice daily who had responded insufficiently to study treatment were allowed to increase the dose. Patients receiving imatinib who had responded insufficiently to study treatment were allowed to cross over to nilotinib. By 60 months, in the intention-to-treat (ITT) population, 31 patients progressed to AP/BC (21 in the imatinib group and 10 in the nilotinib 300 mg twice daily group). The estimated rates of patients free from progression to AP/BC at 60 months were 92.1% in the imatinib group and 96.3% in the nilotinib 300 mg twice daily group (HR=0.4636 between nilotinib 300 mg twice daily group and imatinib).

BCR-ABL Mutations

Study A2303 excluded patients with the BCR-ABL T315I mutation at baseline. In this study, BCR-ABL mutation analysis was performed at baseline and post-treatment. Post-treatment mutation analysis was performed only in a subset of patients when warranted by their clinical course. At baseline, no BCR-ABL mutations were detected for any of the 846 patients enrolled in Study A2303. However, Abl polymorphisms were identified at baseline in some patients with equal distribution among the three treatment arms (23 for nilotinib 300 mg twice daily, 20 for nilotinib 400 mg twice daily, and 17 for imatinib). ABL polymorphism were confirmed by amplifying and sequencing the kinase domain region of both non-translocated ABL alleles in the same samples. Polymorphisms have been reported to have no clinical relevance.

At the 60 month follow-up, 12 patients in the nilotinib 300 mg twice daily arm developed mutations, and 10 of the 12 had at least one of the following mutations: T315I, Y253H, E255K, or F359V mutations. One of the 12 patients in the nilotinib 300 mg twice daily arm with E459K mutation progressed. Eleven patients in the nilotinib 400 mg twice daily arm developed mutations, and 2 patients progressed. All 11 patients had one of the following mutations: T315I, Y253H, E255K/V, F359V or Q252H mutations. Twenty-two patients in the imatinib arm developed mutations, and 8 of 22 had one of the following mutations: T315I, Y253H or F359V/C/I or M244V mutations.

The T315I mutation confers a high level of resistance to nilotinib and most tyrosine kinase inhibitors and is associated with rapid disease progression. The Y253H, E255K/V and F359V/C/I mutations are known to be less sensitive to nilotinib.

Secondary Efficacy Endpoint: Overall survival (OS)

A total of 50 patients died on study, during core treatment, extension treatment or during the follow-up after discontinuation of treatment (18 in the nilotinib 300 mg twice daily group, 10 in the nilotinib 400 mg twice daily group, and 22 in the imatinib 400 mg once daily group). The estimated rates of patients alive at 60 months were 93.7%, versus 91.7%, ($p = 0.4881$ between nilotinib 300 mg twice daily and imatinib) and 96.2% versus 91.7% ($p = 0.0266$ between nilotinib 400 mg twice daily and imatinib). As of the 60 month cutoff date, no overall survival benefit has been demonstrated.

Resistant or intolerant Ph+ CML in chronic phase and accelerated phase (adults)

Study demographics and trial design

The clinical efficacy of nilotinib in imatinib-resistant or -intolerant Ph+ CML in chronic phase (CP) or in accelerated phase (AP) adult patients, has been demonstrated based on the Phase II component of Study (A2101).

The design of Study A2101 is illustrated in Figure 3 below.

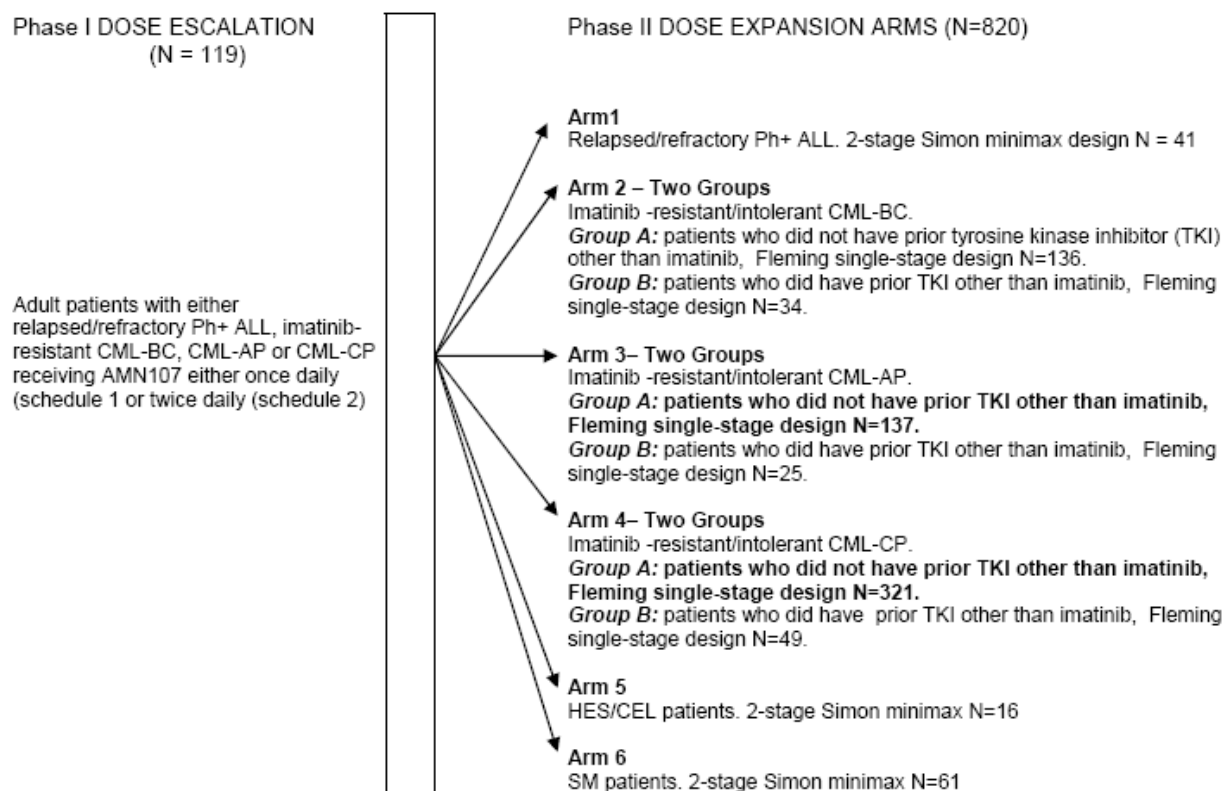

Table 21 Summary of adult patient demographics for clinical trials (imatinib resistant or –intolerant Ph+ CML-AP and CP patients exposed to study drug)

Study #	Trial design	Dosage, route of administration and median duration	Study subjects (n=number)	Mean age (Range)	Gender
A2101	Open label, multicenter, Phase II study to determine the efficacy of TASIGNA in patients with imatinib-resistant or -intolerant CML with separate treatment arms for chronic and accelerated phase CML.	TASIGNA administered orally: 400 mg twice daily (may be dose-escalated to 600 mg twice daily). Treatment duration: 561 days for CP and 264 days for AP	CML-CP (Group A) ¹ = 321 CML-AP (Group A) ¹ = 137	CML-CP (Group A): 31% over the age 65 Mean = 57 Range = 21-85 CML-AP (Group A): 30% over the age 65 Mean = 56 Range=22-82	CML-CP (Group A): M = 50% F = 50% CML-AP (Group A): M=55% F= 45%

¹Group A: patients who did not have prior TKI other than imatinib.

An open label, multicenter, Phase II study (A2101) was conducted to determine the efficacy of TASIGNA in patients with imatinib-resistant or -intolerant CML with separate treatment arms for chronic and accelerated phase CML. The study is ongoing. Efficacy was based on 321 CML-CP patients and 137 CML-AP patients enrolled. Median duration of treatment was 561 days and 264 days, respectively (see Table 22). TASIGNA was administered on a continuous basis (twice daily 2 hours after a meal and no additional food for at least one hour), unless there was evidence of inadequate response or disease progression (see Table 21). Dose escalation to 600 mg twice daily was allowed (see Table 21). A total of 57 CML-CP and 33 CML-AP patients were escalated to the 600 mg twice daily dose.

Table 22 Duration of Exposure with TASIGNA

	Chronic Phase CML N = 321	Accelerated Phase CML N = 137
Median duration of therapy in days (95% CI)	561 (459-680)	264 (190-357)

Study Results:

Resistance to imatinib included failure to achieve a complete hematologic response (by 3 months), cytogenetic response (by 6 months) or major cytogenetic response (by 12 months) or progression of disease after a previous cytogenetic or hematologic response. Imatinib intolerance included patients who discontinued imatinib because of toxicity and were not in major cytogenetic response at time of study entry.

Overall, 70% of CML-CP patients were imatinib-resistant while 30% were imatinib-intolerant. Overall, 80% of CML-AP patients were imatinib-resistant while 20% were imatinib-intolerant. Prior treatment included imatinib, hydroxyurea, interferon, and stem cell transplant (Table 23). The median highest prior imatinib dose had been 600 mg/day for CP and AP patients. The highest prior imatinib dose was ≥ 600 mg/day in 72% of all CML-CP patients and 79% of all CML-AP patients. Thirty-eight (38%) of all CML-CP patients and 45% of all CML-AP patients received imatinib doses ≥ 800 mg/day.

Table 23 CML Disease History Characteristics

	Chronic Phase (n = 321)	Accelerated Phase (n = 137)^{&}
Median time since diagnosis in months (range)	58 (5-275)	71 (2-298)
Imatinib		
Resistant	226 (70%)	-
Resistant without MCyR	-	109 (80%)
Intolerant without MCyR	95 (30%)	27 (20%)
Median time of imatinib treatment in days 95%CI	975 (892-1068)	857 (702-1059)
Prior hydroxyurea	83%	91%
Prior interferon	58%	50%
Prior organ transplant	7%	8%

[&] One patient had missing information for imatinib-resistant/intolerant status

The primary endpoint in the CP patients was major cytogenetic response (MCyR), defined as elimination (complete cytogenetic response, CCyR) or significant reduction to $<35\%$ Ph+

metaphases (partial cytogenetic response, PCyR) of Ph+ hematopoietic cells. The secondary endpoint was complete hematologic response (CHR) in CP patients.

The primary endpoint in the AP patients was overall confirmed hematologic response (HR), defined as either a complete hematologic response (CHR), or no evidence of leukemia (NEL).

Chronic Phase: The MCyR rate in 321 CP patients was 59%. Most responders achieved their MCyR rapidly within 3 months (median 2.8 months) of starting TASIGNA treatment and these responses were sustained. The CCyR rate was 44%. The median time to achieve CCyR was just past 3 months (median 3.3 months). Of the patients who achieved MCyR, 77% (95% CI: 71% to 84%) were maintaining response at 24 months. Median duration of MCyR has not been reached. Of the patients who achieved CCyR, 84% (95% CI: 77% to 91%) were maintaining response at 24 months. Median duration of CCyR has not been reached. Patients with a CHR at baseline achieved a MCyR faster (1.4 vs. 2.8 months). Of CP patients without a baseline CHR, 76% achieved a CHR, median time to CHR was 1 month. Median duration of CHR has not been reached. The response rates for the CP treatment arm are reported in Table 24 and Figure 4.

The estimated 24-month overall survival rate in CML -CP patients was 87%.

Accelerated Phase: The overall confirmed HR rate in 137 AP patients, was 44%. Median duration of confirmed HR was 21.5 months. Of the patients who achieved HR, 50% (95% CI: 35% to 65%) were maintaining response at 24 months. The rate of confirmed CHR was 31%. Median duration of confirmed CHR was 26.3 months. Of the patients who achieved CHR, 51% (95% CI: 34% to 69%) were maintaining response at 24 months. The unconfirmed MCyR rate was 32% with a median time to response of 2.8 months. Of the patients who achieved MCyR, 66% (95% CI: 50% to 82%) were maintaining response at 24 months. Median duration of MCyR has not been reached. The response rates for the AP treatment arm are reported in Table 24.

The estimated 24-month overall survival rate in CML -AP patients was 70%.

Table 24 Responses in CML – adults

(Best Response Rate)	Chronic Phase			Accelerated Phase		
	Intolerant (n = 95)	Resistant (n = 226)	Total (n = 321)	Intolerant (n = 27)	Resistant (n = 109)	Total (n = 137)
Hematologic Response (%)						
Overall (95%CI)	-	-	-	52 (32-71)	41 (32-51)	44 (35-53)
CHR (95%CI)	90% ¹ (79-97)	72% ¹ (64-79)	76% ^{1,3} (70-82)	37 ²	30 ²	31 ²
NEL	-	-	-	15 ²	11 ²	12 ²
Unconfirmed¹ Cytogenetic Response (%)						

Major (95%CI)	66% (56-76)	56% (49-63)	59% (54-65)	41 (22-61)	30 (22-40)	32 (24-41)
Complete	51	41	44	30	19	21
Partial	16	15	15	11	11	11

CHR = Complete hematologic response CCyR = Complete cytogenetic response

NEL = No evidence of leukemia

Hematologic response: CHR+NEL

CHR (CML-CP): WBC <10 x 10⁹ /L, platelets <450,000/mm³, no blasts or promyelocytes in peripheral blood, myelocytes + metamyelocytes <5% in peripheral blood, basophils <5% in peripheral blood, and no extramedullary involvement.

CHR (CML-AP): neutrophils ≥ 1.5 x 10⁹/L, platelets ≥ 100 x 10⁹/L, no myeloblasts in peripheral blood, myeloblast < 5% in bone marrow, basophils <5% in peripheral blood, and no extramedullary involvement.

NEL: same criteria as for CHR but neutrophils ≥ 1.0 x 10⁹/L, platelets ≥ 20 x 10⁹/L without platelet transfusion or bleeding and no requirement for basophils.

Cytogenetic response: Complete (0% Ph+ metaphases) or partial (1-35%). Cytogenetic responses were based on the percentage of Ph-positive metaphases among ≥ 20 metaphase cells in each bone marrow sample.

¹Unconfirmed: Response based on one assessment

²Confirmed: Response assessments confirmed by another assessment at least after 4 weeks).

³ 207 CP patients did not have a CHR at baseline and were therefore assessable for complete hematologic response of which 158 patients (76%) achieved a CHR

Figure 4 Kaplan-Meier estimates of duration of MCyR (months)¹ among CML-CP patients who achieved MCyR - Study CAMN107A2101E2 (Conventional ITT population)

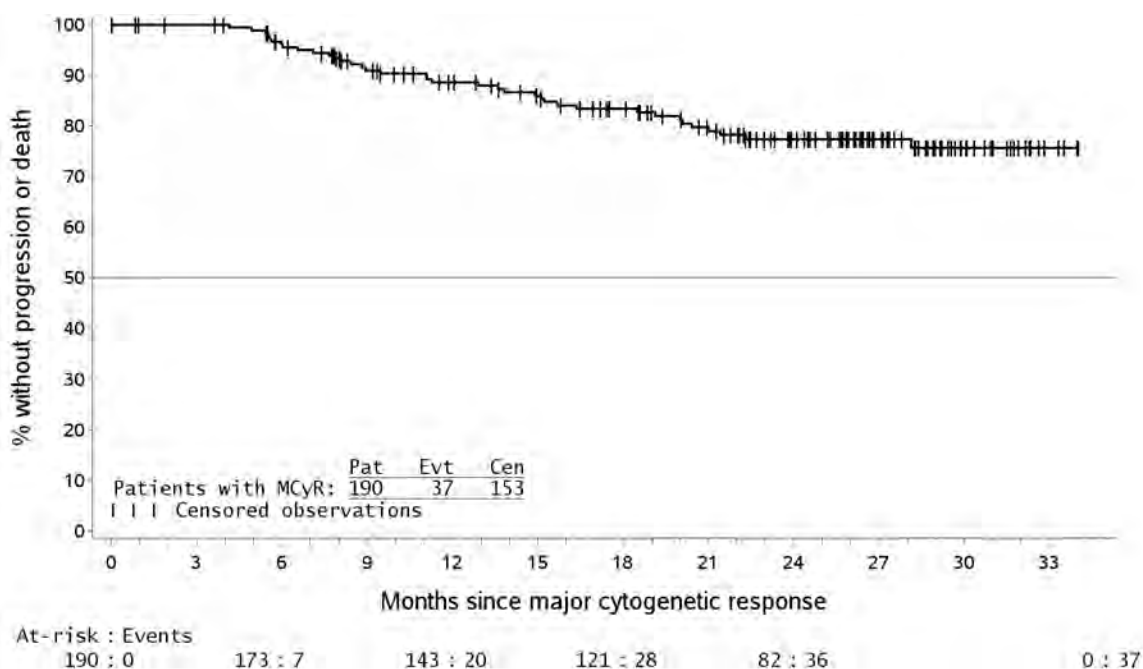

¹Duration defined as time between first documented response to the date of discontinuation due to progression of disease or death.

Separate treatment arms were also included in the Phase II study (A2101) to study TASIGNA in a group of CP and AP patients who had been extensively pre-treated with multiple therapies,

including a tyrosine kinase inhibitor agent in addition to imatinib. Of these patients, 30/36 (83%) were treatment-resistant. In 22 CP patients evaluated for efficacy, TASIGNA induced a 32% MCyR rate and a 50% CHR rate.

After imatinib failure, 24 different BCR-ABL mutations at baseline were noted in 42% of chronic phase and 54% of accelerated phase CML patients who were evaluated for mutations. TASIGNA demonstrated efficacy in patients harboring a variety of BCR-ABL mutations associated with imatinib resistance, except T315I.

Treatment discontinuation in newly diagnosed Ph+ CML-CP patients who have achieved a sustained molecular response (MR4.5)

Table 25 Overview of Treatment Free Remission (TFR) clinical study I2201

Study #	Trial design	Dosage, route of administration and duration	Study subjects (n=number)	Mean age (Range)	Gender
I2201	Phase II, single-arm, multicenter, study of TFR in patients with Ph+ CML-CP who have achieved sustained MRD* status on first-line nilotinib treatment.	Dose: 300 mg nilotinib twice daily. Dose regimen was decreased to 400 mg once daily if patients did not tolerate the planned dose. Duration of treatment consolidation phase: 52 weeks. Duration of TFR phase: median=76 weeks as of 96-week data cut-off.	Total: 215 patients started the consolidation phase of the study 190 patients entered the TFR phase.	Total: 215 Age: 54 (21-86) years 20.5% over age 65 TFR Phase: 190 Age: 54 (21-86) years 21.1% over age 65	Total: 215 M: 113 (52.6%) F: 102 (47.4%) TFR Phase: 190 M: 96 (50.5%) F: 94 (49.5%)

*Sustained minimal residual disease (MRD) is defined as the following results from the last 4 quarterly PCR assessments: MR4.5 at last assessment, no assessment worse than MR4.0 and less than 2 assessments between MR4 and MR4.5.

In an open-label, multicenter, single-arm study, 215 adult patients with Ph+ CML-CP treated with TASIGNA in first-line for ≥ 2 years who achieved MR4.5 as measured with a quantitative diagnostic test validated with a sensitivity of at least MR4.5 ($BCR-ABL/ABL \leq 0.0032\%$ IS) were enrolled to continue TASIGNA treatment for an additional 52 weeks (TASIGNA consolidation phase). Of the 215 patients, 190 patients (88.4%) entered the “Treatment-free Remission” (TFR) phase after achieving a sustained molecular response (MR4.5) during the consolidation phase, defined by the following criteria:

- The last four quarterly assessments (taken every 12 weeks) were at least MR4.0 ($BCR-ABL/ABL \leq 0.01\%$ IS), and maintained for 1 year
- The last assessment being MR4.5 ($BCR-ABL/ABL \leq 0.0032\%$ IS)
- No more than two assessments falling between MR4.0 and MR4.5 ($0.0032\% IS < BCR-ABL/ABL \leq 0.01\%$ IS).

The median age of patients who entered the TFR phase was 55 years, 49.5% were females, and 21.1% of the patients were ≥ 65 years of age. The median actual dose intensity during the 52-week TASIGNA consolidation phase was 600.0 mg/day.

$BCR-ABL$ levels were monitored every 4 weeks during the first 48 weeks of the TFR phase. Monitoring frequency was intensified to every 2 weeks upon the loss of MR4.0. Biweekly monitoring ended at one of the following time points:

- Loss of MMR requiring patient to re-initiate TASIGNA treatment
- When the $BCR-ABL$ levels returned to a range between MR4.0 and MR4.5
- When the $BCR-ABL$ levels remained lower than MMR for 4 consecutive measurements (8 weeks from initial loss of MR4.0).

Any patient with loss of MMR during the TFR phase re-initiated TASIGNA treatment at 300 mg twice daily or at a reduced dose level of 400 mg once daily if required from the perspective of tolerance, within 5 weeks after the collection date of the blood sample demonstrating loss of MMR. Patients who required re-initiation of TASIGNA treatment were monitored for $BCR-ABL$ levels every 4 weeks for the first 24 weeks and then every 12 weeks thereafter in patients who regained MMR.

The primary endpoint was the percentage of patients who were in MMR at 48 weeks after starting the TFR phase (considering any patient who required re-initiation of treatment before 48 weeks as non-responder). Of the 190 patients who entered the TFR phase, 98 patients (51.6% [95% CI: 44.2, 58.9]) were in MMR in the TFR phase at 48 weeks and 93 patients (48.9%, [95% CI: 41.6, 56.3]) were in MMR in the TFR phase at 96 weeks.

By the 96-week analysis data cut-off date, 91 patients (47.9%) discontinued from the TFR phase due to loss of MMR, and 1 (0.5%), 1 (0.5%), 1 (0.5%) and 3 patients (1.6%) due to death from unknown cause, physician decision, lost to follow-up, and subject decision, respectively. Among the 91 patients who discontinued the TFR phase due to loss of MMR, 88 patients restarted TASIGNA treatment and 3 patients permanently discontinued from the study.

Of the 88 patients who restarted treatment due to loss of MMR in the TFR phase, 87 patients (98.9%) patients regained MMR (one patient discontinued study permanently due to subject decision after 7.1 weeks of retreatment without regaining MMR) and 81 patients (92.0%) regained MR4.5 by the time of the 96 week cut-off date.

The time by which 50% of all retreated patients regained MMR and MR4.5 in the retreatment phase was 7.0 and 13.1 weeks, respectively. The cumulative rate of MMR and MR4.5 regained at 24 weeks since treatment re initiation was 97.7% (86/88 patients) and 86.4% (76/88 patients), respectively.

Among the 190 patients in the TFR phase, 98 patients had a treatment-free survival (TFS) event (defined as discontinuation from TFR phase due to any reason, loss of MMR, death due to any cause, progression to AP/BC up to the end of TFR phase, or re-initiation of treatment due to any cause in the study) by the 96-week cut-off date. At 96 weeks, the KM estimated median TFS was 74.6 weeks (95% CI: 36.0, NE) where NE is not estimable, and the KM-estimated 96 weeks TFS rate was 48.9% (95% CI: 41.7, 55.8) (Figure 5).

Figure 5 Kaplan-Meier estimate of treatment-free survival after start of TFR (Full Analysis Set)*

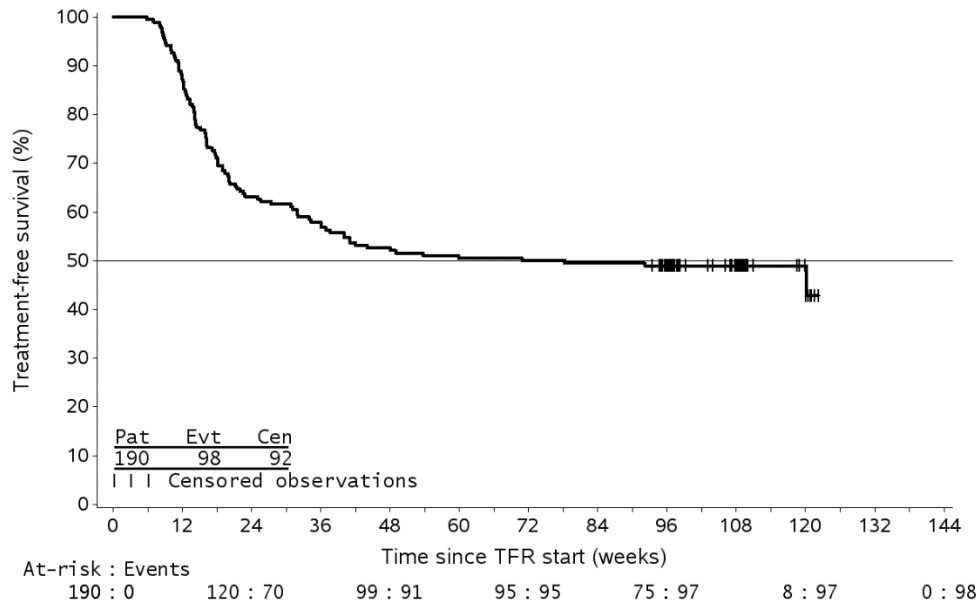

*By the time of the 96-week data cut-off date, one single patient lost MMR at week 120, at the time when only 8 patients were considered at risk. This explains the artificial drop at the end of the curve.

Treatment discontinuation in Ph+ CML-CP patients who have achieved a sustained molecular response (MR4.5) on TASIGNA following prior imatinib therapy

Table 26 Overview of Treatment Free Remission (TFR) clinical study A2408

Study #	Trial design	Dosage, route of administration and median duration	Study subjects (n=number)	Mean age (Range)	Gender
A2408	Phase II, single arm, multicenter study of TFR in Ph+ CML-CP patients after achieving sustained MR4.5 on nilotinib	<p>Dose: Nilotinib: 300 mg or 400 mg twice daily, 400 mg once daily or any other dose received prior to study entry</p> <p>Duration of treatment consolidation phase : 52 weeks</p> <p>Duration of treatment-free remission phase: median=99 weeks as of 96-week data cut-off.</p>	<p>Total: 163 patients started the consolidation phase of the study</p> <p>126 patients entered the TFR phase</p>	<p>Total 163</p> <p>Age 564.3 (21-86) years</p> <p>24.5% over age 65.</p> <p>TFR Phase:126</p> <p>Age 55 (21-86 years)</p> <p>27.8% over age 65.</p>	<p>Total : 163</p> <p>M: 77 (47.2%)</p> <p>F: 86 (52.8%)</p> <p>TFR Phase: 126</p> <p>M: 56 (44.4%)</p> <p>F: 70 (55.6%)</p>

In an open-label, multicenter, single-arm study, 163 adult patients with Ph+ CML-CP taking tyrosine kinase inhibitors (TKIs) for ≥ 3 years (imatinib as initial TKI therapy for more than 4 weeks without documented MR4.5 on imatinib at the time of switch to TASIGNA, then switched to TASIGNA for at least 2 years), and who achieved MR4.5 on TASIGNA treatment as measured with a quantitative diagnostic test validated with a sensitivity of at least MR4.5 ($BCR-ABL/ABL \leq 0.0032\%$ IS) were enrolled to continue TASIGNA treatment for an additional 52 weeks (TASIGNA consolidation phase). Of the 163 patients, 126 patients (77.3%) entered the TFR phase after achieving a sustained molecular response (MR4.5) during the consolidation phase, defined by the following criterion:

- The last four quarterly assessments (taken every 12 weeks) showed no confirmed loss of MR4.5 ($BCR-ABL/ABL \leq 0.0032\%$ IS) during 1 year.

The median age of patients who entered the TFR phase was 56 years, 55.6% were females, and 27.8% of the patients were ≥ 65 years of age. The median actual dose intensity during the 52-week TASIGNA consolidation phase was 771.8 mg/day with 52.4%, 29.4%, 0.8%, 16.7% and 0.8% of patients receiving a daily TASIGNA_dose of 800 mg, 600 mg, 450mg, 400mg and 300mg just before entry into the TFR phase, respectively.

Patients who entered the TFR phase but experienced two consecutive measurements of $BCR-ABL/ABL > 0.01\%$ IS were considered having a confirmed loss of MR4.0, triggering re-initiation of TASIGNA treatment. Patients with loss of MMR in the TFR phase immediately restarted TASIGNA treatment without confirmation. All patients who restarted TASIGNA therapy had $BCR-ABL$ transcript levels monitored every 4 weeks for the first 24 weeks, then once every 12 weeks.

The primary endpoint was defined as the proportion of patients without confirmed loss of MR4.0 or loss of MMR within 48 weeks following discontinuation of TASIGNA therapy. Of the 126 patients who entered the TFR phase, 73 patients (57.9%, [95% CI: 48.8, 66.7]) did not have loss of MMR, or confirmed loss of MR4.0, or re-initiation of TASIGNA therapy within 48 weeks, and in 67 patients (53.2% [95% CI: 44.1, 62.1]) within 96 weeks after the start of the TFR phase.

By the 96-weeks analysis data cut-off date, 61 patients (48.4%) discontinued from the TFR phase: 58 patients (46.0%) due to loss of MMR or confirmed loss of MR4.0, 2 patients (1.6%) due to subject/guardian decision and one patient (0.8%) due to pregnancy. Among the 58 patients who discontinued from the TFR phase due to confirmed loss of MR4.0 or loss of MMR, 56 patients restarted TASIGNA therapy and 2 patients permanently discontinued from the study. Of the 56 patients who restarted TASIGNA treatment due to confirmed loss of MR4.0 or loss of MMR in the TFR phase, 52 patients (92.9%) regained MR4.0 and MR4.5; 4 patients (7.1%) did not regain MR4.0 by the time of the cut-off date.

The time by which 50% of all retreated patients regained MR4.0 and MR4.5 in the retreatment phase was 12 weeks and 13.1 weeks respectively. The cumulative rate of MR4.0 and MR4.5 regained by 48-weeks since treatment re-initiation, was 92.9% (52/56 patients) and 91.1% (51/56 patients), respectively.

Among the 126 patients in the TFR phase, 61 patients (48.4%) had a treatment-free survival (TFS) event (defined as discontinuation from TFR phase due to any reason, loss of MMR, confirmed loss of MR4.0, death due to any cause, progression to AP/BC up to the end of TFR phase, or re-initiation of treatment due to any cause in the study) on or before the 96-month cut-off date. At 96 weeks, the KM estimated median TFS was 111.0 weeks (95% CI: 27.9, NE) where NE is not estimable, and the KM-estimated TFS rate was 54.0% (95% CI: 44.9, 62.2) (Figure 6).

Figure 6 Kaplan-Meier estimate of treatment-free survival after start of TFR (Full Analysis Set)

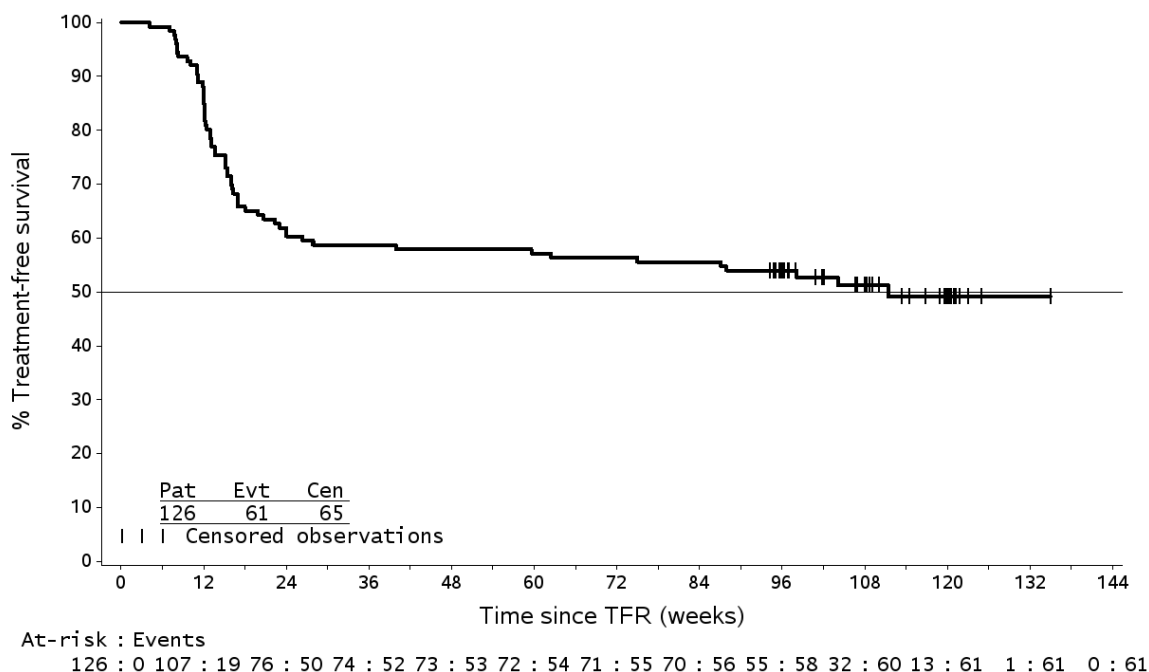

Table 27 Summary of pediatric patient demographics for clinical trials (Newly diagnosed and resistant / intolerant Ph+ CML-CP patients exposed to TASIGNA)

Study #	Trial design	Dosage, route of administration and median duration	Study subjects (n=number)	Mean age (Range) n (%)	Gender n (%)
CAMN107A 2203	A multi-centre, open label, non-controlled Phase II study to evaluate the efficacy and safety of oral nilotinib in pediatric patients (1 to <18 years old) with newly diagnosed Ph+ chronic myeloid leukemia (CML) in chronic phase (CP) or with Ph+ CML in CP or accelerated phase (AP) resistant or intolerant to either imatinib or dasatinib	50mg, 150mg and 200 mg capsules 230 mg/m ² twice daily . Median time on treatment: Resistant/intolerant CML-CP: 15.6 months Newly diagnosed CML-CP: 14.6 months	Total: 58 Patients Resistant/intolerant CML-CP: 33 patients Newly diagnosed CML-CP: 25 Patients	Imatinib/dasatinib resistant/intolerant CML-CP patients. Mean 12.4 (2-17) 2 to <12 years: 12(36.4%) 12to<18 years: 21 (63.6%) Newly diagnosedCML-CP patients Mean 13.2 (10-16) 2 to 12 years: 6 (24.0%) 12 to <18 years: 19 (76.0%)	Imatinib/dasatinib resistant/intolerant CML-CP patients. M : 21(63.6%) F : 12 (36.4%) Newly diagnosed CML-CP patients M: 13 (52.0%) F: 12 (48.0%)

CAMN107A 2120	A Phase I, multi-center, open-label study to characterize the PK of nilotinib in the study population administered as 230 mg/m ² bid to pediatric patients with newly diagnosed chronic phase (CP) Ph+ CML, with CP or accelerated phase (AP) Ph+ CML resistant/intolerant to imatinib and /or dasatinib, or with refractory/relapsed Ph+ ALL.	Forms: capsules Doses: administered nilotinib 230 mg/m ² twice daily Median time on treatment: Group 1: 11.0 months Group 2: 10.8 months	Total: 15 patients Group 1: Ph+CML: 5 patients Ph+ALL: 3 patients. Group 2: Ph+ CML: 6 patients Ph+ALL: 1 patients.	Group1: Mean 6.8 (10-16) Group 2: Mean 13.7 (10-17)	Group1: M: 5 (62.5%) F: 3 (37.5%) Group 2: M: 3 (42.9%) F: 4 (57.1%)
------------------	---	---	---	--	---

Pediatric patients with newly diagnosed Ph+ CML-CP or resistant/ intolerant Ph+ CML-CP

The safety and efficacy of nilotinib in pediatric patients with Ph+ CML-CP have been investigated in two open-label single arm studies (Phase 1, CAMN107A2120 and Phase 2 CAMN107A2203). The data presented here are from a pooled analysis of final data from CAMN107A2120 and data with cut-off date of 01-Jun-2016 (all patients had completed 12 x 28-day cycles or discontinued) from CAMN107A2203. A total of 69 pediatric patients (from 2 to <18 years of age) with either newly diagnosed Ph+ CML-CP (n=25) or imatinib/dasatinib resistant or intolerant Ph+ CML-CP (n=44) received nilotinib at a dose of 230 mg/m² twice daily, rounded to the nearest 50 mg dose (to a maximum single dose of 400 mg), approximately 12 hours apart.

In the pooled CML patient population (N=69), the median actual dose intensity was 435.5 mg/m²/day (range: 149 to 517 mg/m²/day), and the median relative dose intensity was 94.7% (range: 32 to 112%). Forty patients (58.0%) had relative dose intensity above 90%. The median time on treatment with nilotinib was 13.80 months (range: 0.7 to 30.9 months).

Study Results

In the resistant or intolerant CML patients (N=44), the primary efficacy endpoint, major molecular response (MMR; BCR-ABL/ABL ≤0.1% IS) rate at 6 cycles, was 34.1% (95% CI: 20.5, 49.9) with 15 patients being in MMR.

In the newly diagnosed CML patients (N=25), the two primary efficacy endpoints were MMR rate by 12 cycles and CCyR rate at 12 cycles. The MMR rate by 12 cycles was 64.0% (95% CI: 42.5, 82.0) , with 16 patients achieving MMR and the CCyR rate at 12 cycles was 64.0% (95% CI: 42.5, 82.0) with 16 patients achieving CCyR.

Table 28 Rate of Major Molecular Response*

	Resistant or intolerant CML patients N=44	Newly diagnosed CML patients N=25
At 6 cycles		
n (%)	15 (34.1)	13 (52.0)
95% CI for response	[20.5,49.9]	[31.3,72.2]
At 12 cycles		
n (%)	18 (40.9)	15 (60.0)
95% CI for response	[26.3,56.8]	[38.7,78.9]
By 12 cycles		
n (%)	21 (47.7)	16 (64.0)
95% CI for response	[32.5, 63.3]	[42.5, 82.0]

* MMR, BCR-ABL/ABL \leq 0.1% IS

Among the 21 resistant or intolerant CML patients who were in MMR at any time on treatment, the median time to first MMR was 2.76 months (95% CI: 0.03, 5.55). For the 17 newly diagnosed CML patients who achieved MMR, the median time to first MMR was 5.55 months (95% CI: 5.52, 5.75).

The magnitude of molecular response achieved is presented in Table 28.

Table 29

Proportions of patients who had best BCR-ABL ratio category of MR4.0 and MR4.5*

	Resistant or intolerant CML patients N=44 n (%)	Newly diagnosed CML patients N=25 n (%)
MR4.0 (BCR-ABL/ABL \leq0.01% IS)	5 (11.4)	8 (32.0)
MR4.5 (BCR-ABL/ABL \leq0.0032% IS)	2 (4.5)	7 (28.0)

* by the cut-off date

None of the 21 resistant or intolerant CML patients who were in MMR on treatment, had confirmed loss of MMR. Among the 17 newly diagnosed CML patients who achieved MMR, one

patient had confirmed loss of MMR (the patient lost CHR due to an increase in basophil count, however, did not progress to AP/BC).

One resistant or intolerant CML patient progressed to AP/BC after about 10 months on treatment.

DETAILED PHARMACOLOGY

Animal Pharmacodynamics

Nilotinib has been evaluated in preclinical studies as either the free-base (AMN107-NX) or as a mono-hydrochloride salt (AMN107-AA), and has been developed as an oral formulation of the mono-hydrochloride salt. Both AMN107-NX and AMN107-AA are absorbed following oral administration to animals, and the compound is tolerated at doses showing efficacy in murine myeloproliferative disease models.

In vitro and *in vivo* pharmacology studies have been carried out to characterize and define the activity and selectivity of nilotinib (AMN107-NX). For *in vitro* studies both human CML cell lines and murine hematopoietic cells lines have been employed to characterize the antileukemic properties of the compound, and the latter cells have been employed for *in vivo* efficacy studies with nilotinib (both AMN107-NX and AMN107-AA) in mice. To assess selectivity, nilotinib (AMN107-NX) was evaluated for effects on kinase autophosphorylation and cell viability, using either engineered murine Ba/F3 cells, whose survival is dependent on the expression of constitutively activated (oncogenic) kinases, or cancer cell lines expressing the appropriate kinase.

Animal Safety pharmacology

Safety pharmacology studies were conducted to assess the safety of nilotinib in particular organ systems.

CNS safety pharmacology

The interactions of nilotinib has been evaluated in a panel of 79 *in vitro* binding assays for potential effects on G-protein coupled receptors, cell transporters, ion channels, nuclear receptors and enzymes. No significant effects on ligand-binding were seen at concentrations < 4.0 μM , other than for the human adenosine 3 receptor (IC_{50} values 2.4 and 4.2 μM) and the human adenosine transporter (IC_{50} values 0.9 and 3.5 μM).

Oral administration of nilotinib at doses up to 300 mg/kg to rats demonstrated no effects on CNS.

Respiratory effects

Oral administration of nilotinib at doses up to 300 mg/kg to rats demonstrated no effect on respiratory rate, tidal volume or minute volume.

Cardiovascular effects

A variety of *in vitro* and *in vivo* studies were conducted to explore possible cardiovascular effects of nilotinib. *In vitro* studies with BJA873 (the nilotinib metabolite, P36.5) were also performed.

In vitro cardiac safety studies demonstrated a preclinical signal for QT prolongation. No effects were seen in ECG measurements in dogs or monkeys treated up to 39 weeks or in a special telemetry study in dogs. In neonatal rat ventricular myocytes (NRVM) nilotinib ($\geq 3.7 \mu\text{M}$) increased the ratio of XBP1 mRNA spliced/un-spliced, an endoplasmic reticulum stress marker, but a reduction in cellular ATP content in NRVM was observed at a concentration of $\geq 11 \mu\text{M}$. Nilotinib produced increases in heart weights and/or left ventricular mass in rats at 40 mg/kg and 80 mg/kg for 4 weeks treatment without histopathological or structural changes.

Animal pharmacokinetics

The program of nonclinical pharmacokinetics for nilotinib consisted of radiolabeled ADME studies in the species used for chronic toxicity testing (rat and monkey) as well as in mouse, rabbit, and human. Both oral and intravenous dosing routes were evaluated in all species except human (oral dosing only) to allow estimates of absorption and bioavailability to be made. Additional information obtained from the ADME studies included pharmacokinetic parameters of parent drug and total radioactivity, routes and rates of excretion, metabolic pathways, and mass balance. Nilotinib tissue distribution studies were performed in pigmented and non-pigmented rats. The placenta transfer of nilotinib was also investigated in pregnant rats and rabbits. The evaluation of milk excretion of nilotinib was performed in rats. *In vitro* studies with nilotinib were performed to assess blood-plasma distribution, protein binding, phenotyping of enzymes responsible for metabolism, enzyme inhibition and induction, and interactions with drug transporters.

Nilotinib is moderately absorbed in all species tested including human, with relatively high protein binding that is comparable across species. A decrease in the α_1 -acid glycoprotein concentration may, in theory, decrease nilotinib plasma protein binding. However, this effect would be limited due to the significant binding to serum albumin. Nilotinib and/or its metabolites was mainly distributed to adrenal cortex, liver, uveal tract, and small intestine while it showed minimal brain and testis penetration which was consistent with the lack of any toxic effects being observed in these organs. Nilotinib and/or its metabolites showed some passage to the fetus which may account for the incidence of embryolethal and embryotoxicity.

In general, all of the major metabolic pathways observed in humans were also observed in the toxicological test species (mouse, rat, rabbit, and monkey).

Excretion occurred almost exclusively through the fecal route with a minor renal elimination in all species, especially in human. Liver function and drug-drug interactions (enzymes or Pgp) in the liver may affect the elimination of nilotinib.

In vitro cytochrome P450 phenotyping experiments indicated that CYP3A4 should be the main enzyme contributing to the oxidative metabolism of nilotinib *in vivo*. Accordingly, a clinical

drug-drug interaction study showed that the metabolism of nilotinib could be reduced by co-administration of the CYP3A4 inhibitor, ketoconazole.

In vitro enzyme inhibition studies performed in human liver microsomes revealed that nilotinib could act as an inhibitor of CYP2C8, CYP2C9, CYP2D6, and CYP3A4/5 activity in the clinic and possibly, but less likely, CYP2C19. Nilotinib displayed no potential for time-dependent inhibition (i.e., no mechanism-based inactivation) of any of these enzymes.

Experiments examining the effect of increasing concentrations of nilotinib on bilirubin and estradiol glucuronidation activity suggest that nilotinib could inhibit the activity of UGT1A1 in the clinic. Enzyme induction studies indicate that nilotinib can be considered to be an *in vitro* inducer of CYP2B6, CYP2C8, and CYP2C9 activities (and possibly, CYP3A4 as well). Nilotinib was also found to be a substrate (efflux ratios ≈ 4 at a nilotinib concentration of 6 μM) for the P-gp transporter as well as a possible inhibitor of P-gp in the clinic.

Exposures were generally proportional to the dose in mice, rats, and rabbits but underproportional in dogs, monkeys, and human. There was no clear evidence of gender differences in the exposure for mice, monkeys and dogs, while for the rat, females showed somewhat higher exposure than males. No clear evidence of accumulation for rats and dogs was observed, while the monkey showed moderate accumulation.

TOXICOLOGY

Nilotinib has been evaluated in single dose toxicity, repeated dose toxicity, genotoxicity, reproductive toxicity, phototoxicity, carcinogenicity (rat and mice) studies.

Repeat-dose toxicity studies were conducted in rodents and non-rodents up to nine months in duration. Nilotinib was generally well tolerated and no toxicities prohibitive for use in humans were identified. The rat and cynomolgus monkey were selected as the rodent and non-rodent species for chronic toxicity testing as both species are used routinely as animal models in toxicity evaluations. All of the major metabolic pathways observed in humans were also observed in the toxicological test species (mouse, rat, rabbit, and monkey). Accordingly, all of the metabolites identified in humans were also detected in one or more of the animal species tested, with the exception of two minor fecal metabolites that accounted for 0.62% and 1.2% of the dose, respectively. There were no glutathione or cysteine-related adducts indicative of reactive metabolite formation detected in any of the species.

Single oral dose toxicity study

No single dose oral toxicity studies were performed.

Single-dose intravenous toxicity study

Nilotinib administered to rats at a single intravenous dose of 9 mg/kg did not induce any toxicologically relevant changes attributable to nilotinib and therefore this dose was considered to be the No-Observed-Adverse-Effect-Level (NOAEL).

Potentially vehicle related lesions were observed after the 14-day recovery period. Several animals which received vehicle alone or together with test item showed minimal acute or subacute focal necrosis in the brain. The distribution was considered consistent with ischemic/hypoxic changes, probably as a result of the volume of drug solution applied. No lesions were observed in animals sacrificed one day after the administration.

Repeated dose toxicity

Repeated dose toxicity studies in mice, rats, dogs and cynomolgus monkeys were conducted as indicated in Table 30 below. The doses presented in this section are expressed in terms of the free base.

Table 30 Repeated dose toxicity studies

Species (strain)	Study duration	Route of administration	Dose (mg/kg/day)	Gender and no of animals per group	Study Number
Mouse (OF1) non GLP	2-week tolerability	oral (gavage)	0, 50, 150, 450	5 m in control 6 m at 50, 150 and 450 mg/kg	[02R143]
Mouse [CrI:CD-1 (ICR)] non GLP	4-week range finding	oral (in feed)	0, 20, 60, 180	10 m + 10 f	[0580231]
Rat (CrI:Wist Han) non GLP	Rising dose, day 1, 3 & 5	oral (gavage)	50→250→500	2 m + 2 f	[0370053]
	4 days		750	2 m + 2 f	
Rat (CrI:Wist Han) non GLP	2-week range finding	oral (gavage)	0, 30, 100, 300	5 m + 5 f	[0370138]
Rat (CrI:Wist Han) GLP	4-week + 4-week recovery	oral (gavage)	0, 6, 20, 60	10 m + 10 f 6 m + 6 f for recovery in control and high dose groups	[0370146]
Rat (CrI:Wist Han) GLP	4-week	oral (gavage)	0, 20, 80	10 m + 10 f	[0510076]
Rat (CrI:Wist Han)IGS non GLP	4-week range finding	oral (in feed)	0, 20, 60, 180	6 m + 6 f	[0580230]
Rat	26-week +	oral (gavage)	0, 6, 20, 60	20 m + 20 f	[0580158]

(Ctrl:Wist Han) GLP	4-week recovery				10 m + 10 f for recovery in control and high dose groups
Dog (Beagle) non GLP	Rising dose, day 1, 3 & 5 4 days	oral (gavage)	100→300→600 600	1 m + 1 f 1 m + 1 f	[0370052]
Dog (Beagle) non GLP	2-week range finding	oral (gavage)	0, 6, 20, 60	1 m + 1 f 2 m + 2 f in high dose only	[0370139]
Dog (Beagle) GLP	4-week + 4-week recovery	oral (gavage)	0, 5, 15, 45	3 m + 3 f 2 m + 2 f for recovery in control and high dose group	[0370147]
Monkey (cynomolgus) non GLP	Rising dose, day 1, 3 & 6 8 days	oral (gavage)	100→200→400 600	1 m + 1 f 1 m + 1 f	[0470193]
Monkey (cynomolgus) non GLP	4-week	oral (gavage)	0, 100, 200, 400, 600	1 m + 1 f 2 m + 2 f in high dose group	[0570038]
Monkey (cynomolgus) GLP	39-week + 4-week recovery	oral (gavage)	0, 30, 200, 600	4 m + 4 f 2 m + 2 f for recovery in control and high dose groups	[0580157]

f = female animals; m = male animals

Repeated dose toxicity studies in dogs up to 4 weeks duration and in cynomolgus monkeys up to 9 months duration, revealed the liver as the primary target organ of toxicity of nilotinib. Alterations included increased alanine aminotransferase and alkaline phosphatase activity, and histopathology findings (mainly sinusoidal cell or Kupffer cell hyperplasia/hypertrophy, bile duct hyperplasia and periportal fibrosis). In general the changes in clinical chemistry were fully reversible after a four week recovery period, the histological alterations only showed partial reversibility. Exposures at the lowest dose levels where the liver effects were seen were lower than the exposure in humans at a dose of 800 mg/day. Only minor liver alterations were seen in mice or rats treated up to 26 weeks. Although mainly reversible increases in cholesterol levels were seen in rats, dogs and monkeys, a lack of recovery in serum total cholesterol was observed in one female monkey (no evidence of recovery was apparent during the recovery duration) with a lack of reversibility of morphological liver changes in one male monkey. In the 2-year rat carcinogenicity study, the major target organ for non-neoplastic lesions was the uterus (dilatation, vascular ectasia, hyperplasia endothelial cell, inflammation and/or epithelial hyperplasia).

Genotoxicity

Genotoxicity studies in bacterial *in vitro* systems and in mammalian *in vitro* and *in vivo* systems with and without metabolic activation did not reveal any evidence for a mutagenic potential of nilotinib.

Carcinogenesis

In the 2-year rat carcinogenicity study conducted orally at TASIGNA at 5, 15, and 40 mg/kg/day, there was a non-statistically significant increased incidence of uterine hemangiosarcoma, adenocarcinoma and squamous cell carcinoma and an increase in follicular cell adenoma in the thyroid gland (barely reaching statistical significance). Given that the incidence of thyroid follicular cell adenoma and uterine adenocarcinoma were within the historical control range, the data do not clearly indicate that TASIGNA is carcinogenic in rats.

An increased mortality in female rats given nilotinib at ≥ 15 mg/kg/day for up to 104 weeks was observed, which was often associated with gross or microscopic uterine changes. Exposures (in terms of AUC) at the highest dose level were represented approximately 2x to 3x human daily steady state exposure at the nilotinib dose of 800 mg/day.

In the 26-week Tg.rasH2 mouse carcinogenicity study, in which nilotinib was administered at 30, 100 and 300 mg/kg/day, skin papillomas/carcinomas were detected at 300 mg/kg, representing approximately 30 to 40 times (based on AUC) the human exposure at the maximum approved dose of 800 mg/day (administered as 400 mg twice daily). The No-Observed-Effect-Level for the skin neoplastic lesions was 100 mg/kg/day, representing approximately 10 to 20 times the human exposure at the maximum approved dose of 800 mg/day (administered as 400 mg twice daily). The major target organs for non-neoplastic lesions were the skin (epidermal hyperplasia), the growing teeth (degeneration/atrophy of the enamel organ of upper incisors and inflammation of the gingiva/odontogenic epithelium of incisors) and the thymus (increased incidence and/or severity of decreased lymphocytes).

Reproductive toxicity studies

Nilotinib did not induce teratogenicity, but did show embryo- and fetotoxicity at doses which also showed maternal toxicity. Increased post implantation loss was observed in both the fertility study, with treatment of both males and female rats, and in the embryotoxicity study with the treatment of female rabbits. Embryo-lethality and fetal effects (mainly decreased fetal weights, visceral and skeletal variations) in rats and increased resorption of fetuses and skeletal variations in rabbits were present in the embryotoxicity studies. Exposure to nilotinib in females at No-Observed-Adverse-Effect-Levels was generally less or equal to that in humans at 800 mg/day.

In a pre- and postnatal study, the oral administration of nilotinib to female rats from day 6 of gestation to day 21 or 22 post-partum resulted in maternal effects (reduced food consumption and lower body weight gains) and longer gestation period at 60 mg/kg. The maternal dose of 60 mg/kg was associated with decreased pup body weight and changes in some physical development parameters (the mean day for pinna unfolding, tooth eruption and eye opening was earlier). The No-Observed-Adverse-Effect-Level in maternal animals and offspring was a maternal dose of 20 mg/kg.

Phototoxicity

Nilotinib was shown to absorb light in the UV-B and UV-A range, and to be distributed into the skin showing a phototoxic potential *in vitro*. However, no phototoxicity has been observed *in vivo*. Therefore the risk that nilotinib causes photosensitization in patients is considered very low.

REFERENCES

- 1 Baccarani M, Saglio G, Goldman J, et al (2006) Evolving concepts in the management of chronic myeloid leukemia. Recommendations from an expert panel on behalf of the European Leukemianet. *Blood*, prepublished online May 18, 2006; DOI 10.1182/blood-2006-02-005686.
- 2 Branford S and Hughes T (2006) Diagnosis and Monitoring of Chronic Myeloid Leukemia by Qualitative and Quantitative RT-PCR. *Methods Mol Med*; 125:69-92.
- 3 Berman E, Nicolaidis M, Maki RG, et al (2006) Altered Bone and Mineral Metabolism in Patients Receiving Imatinib Mesylate. *N Engl J Med*; 354:2006-2013.
- 4 Chronic Myeloid Leukemia Trialists' Collaborative Group (1997) Interferon alfa versus chemotherapy for chronic myeloid leukaemia: a meta-analysis of seven randomized trials. *J Natl Cancer Inst*; 89:1616-1620.
- 5 Cortes JE, Jones D, O'Brien S, et al (2010) Nilotinib as front-line treatment for patients with chronic myeloid leukemia in early chronic phase. *J Clin Oncol.* ;28(3):392-7.
- 6 Cowan-Jacob SW, Guez V, Fendrich G, et al (2004) Imatinib (STI571) Resistance in Chronic Myelogenous Leukemia: Molecular Basis of the Underlying Mechanisms and Potential Strategies for Treatment. *Mini-Rev Med Chem*; 4:285-99.
- 7 Deininger M (2005) ASH annual meeting: Chronic Myeloid Leukemia. Management of early stage disease. *Hematology*: 174-82.
- 8 Druker B, Gathmann I, Bolton AE, et al (2003) ASH annual meeting: Chronic Myelogenous Leukemia. Probability and impact of obtaining a cytogenetic response to imatinib as initial therapy for chronic myeloid leukemia (CML) in chronic phase. *Blood*; 102:A634.
- 9 Druker B, Guilhot F, O'Brien S, et al (2006) Five-Year Follow-up of Patients Receiving Imatinib Chronic Myelogenous Leukemia in Chronic Phase. *New Engl. J. Med.*;355:2408-17.
- 10 Ebnöether M, Stentoft J, Ford J, et al (2002) Cerebral oedema as a possible complication of treatment with imatinib *Lancet*; 359(9319):1751-52. ~
- 11 Gorre M, Mohammed M, Ellwood K, et al (2001) Clinical Resistance to STI-571 Cancer Therapy Caused by BCR-ABL Gene Mutation or Amplification. *Science*; 293:876-80
- 12 Hochhaus A, Masszi T, Giles FJ et al. (2017) Treatment-free remission following frontline nilotinib in patients with chronic myeloid leukemia in chronic phase: results

from the ENESTfreedom study. *Leukemia*. Jul;31(7):1525-1531. doi: 10.1038/leu.2017.63. Epub 2017 Feb 20.

- 13 Hochhaus A., Saglio G., Larson L.A, et al. (2013) Nilotinib is associated with a reduced incidence of BCR-ABL mutations versus imatinib in patients with newly diagnosed chronic myeloid leukemia in chronic phase *Blood* First Edition Paper, prepublished online March 15, 2013; DOI 10.1182/blood-2012-04-423418.
- 14 Hochhaus A, La Rosee P (2004) Imatinib therapy in chronic myelogenous leukemia: strategies to avoid and overcome resistance. *Leukemia*; 18:1321-31.
- 15 Hughes TP, Saglio G, Kantarjian HM, et al. (2014) Early molecular response predicts outcomes in patients with chronic myeloid leukemia in chronic phase treated with frontline nilotinib or imatinib. *Blood*. Feb 27;123(9):1353-60.
- 16 Jayson GC, Parker GJM, Mullamitha S, et al (2005) Blockade of Platelet-Derived Growth Factor Receptor-Beta by CDP860, a Humanized, PEGylated di-Fab', Leads to Fluid Accumulation and Is Associated With Increased Tumor Vascularized Volume. *J Clin Oncol*; 23(5):973-81.
- 17 Kantarjian HM, Dixon D, Keating M, et al (1988) Characteristics of accelerated disease in chronic myelogenous leukemia. *Cancer*; 61:1441-46.
- 18 Kantarjian HM, Talpaz M (1988) Definition of the accelerated chronic of chronic myelogenous leukemia. *J Clin Oncol*; 6(1):180-82.
- 19 Kantarjian H, Sawyers C, Hochhaus A, et al (2002) Hematologic and cytogenetic responses to imatinib mesylate in chronic myeloid leukemia. *New Engl J Med*; 346:645-52.
- 20 Kantarjian H, Giles F, Wunderle L, et al (2006) Nilotinib in imatinib-resistant CML and Philadelphia chromosome-positive ALL. *N Engl J Med*; 354(24):2542-2551.
- 21 Kantarjian H, Giles F, Gattermann N. (2007), Nilotinib (formerly AMN107), a highly selective BCR-ABL tyrosine kinase inhibitor, is effective in patients with Philadelphia chromosome-positive chronic myelogenous leukemia in chronic phase following imatinib resistance and intolerance. *Blood*; 110: 3540-3546.
- 22 Kantarjian H., Giles F.J, Bhalla K.N.P, Pinilla J., Larson R.A., et al. (2011), Nilotinib is effective in patients with chronic myeloid leukemia patients in chronic phase imatinib resistance or intolerance: 24-month follow-up results. *Blood*; 117(4):1141-5.
- 23 Kantarjian H., Hochhaus A., Saglio G., et al. (2011) Nilotinib versus imatinib for the treatment of patients with newly diagnosed chronic phase, Philadelphia chromosome-positive, chronic myeloid leukaemia: 24-month minimum follow-up of the phase 3 randomised ENESTnd trial. *Lancet* Published online August 18, 2011; DOI:10.1016/S1470-2045(11)70201-7.

- 24 Le Coutre P.D, Giles F.J, Hochhaus A., Apperley J. F., Ossenkoppele G.J, et al. (2012), Nilotinib in patients with Ph+ chronic myeloid leukemia in accelerated phase following imatinib resistance or intolerance: 24-month follow-up results *Leukemia* 26, 1189-1194.
- 25 RA Larson, A Hochhaus, TP Hughes, et al (2012) Nilotinib vs imatinib in patients with newly diagnosed Philadelphia chromosome-positive chronic myeloid leukemia in chronic phase: ENESTnd 3-year follow-up. *Leukemia*; 1-7.
- 26 Mahon, F-X, Boquimpani Carla, Dong-Wook Kim et al (2018) Treatment-Free Remission After Second-Line Nilotinib Treatment in Patients With Chronic Myeloid Leukemia in Chronic Phase; Results From a Single-Group, Phase 2, Open-Label Study: *Annals of Internal Medicine*.
- 27 O'Brien SG, Guilhot F, Larson RA, et al (2003) Imatinib compared with interferon and lowdose cytarabine for newly diagnosed chronic-phase chronic myeloid leukemia. *N Engl J Med*; 348:994-1004.
- 28 O'Hare T, Corbin AS, Druker BJ (2006) Targeted CML therapy: controlling drug resistance, seeking cure. *Curr Opin Genet Dev*; 16(1):92-99.
- 29 Pietras K, Östman A, Sjöquist M, et al (2001) Inhibition of Platelet-derived Growth Factor Receptors Reduces Interstitial Hypertension and Increases Transcapillary Transport in Tumors. *Cancer Research*; 61:2929-34.
- 30 Rosti G, Palandri F, Castagnetti F, et al (2009) GIMEMA CML Working Party. Nilotinib for the frontline treatment of Ph(+) chronic myeloid leukemia. *Blood*.;114(24):4933-8.
- 31 Saglio G, Kim DW, Issaragrisil S, le Coutre P, et al (2010) Nilotinib versus imatinib for newly diagnosed chronic myeloid leukemia. *N Engl J Med*.;362(24):2251-9.
- 32 Sawyers C, Hochhaus A, Feldman E, et al (2002) Imatinib induces hematologic and cytogenetic responses in patients with chronic myeloid leukemia in myeloid blast crisis: results of a phase II study. *Blood*; 99:3530-39.
- 33 Silver RT, Talpaz M, Sawyers C, et al (2004) Four years of follow-up of 1027 patients with late chronic phase (L-CP), accelerated phase (AP) or blast crisis (BC) chronic myeloid leukemia (CML) treated with imatinib in three large phase II trials [abstract]. *Blood*; 104(11a):A23.
- 34 Talpaz M, Silver RT, Druker BJ (2002) Imatinib induces durable hematologic and cytogenetic responses in patients with accelerated phase chronic myeloid leukemia: results of a phase 2 study. *Blood*; 99(6):1928-37.

- 35 Weisberg E, Manley PW, Breitenstein W et al (2005) AMN107: Characterization of a novel inhibitor of both wild-type and imatinib-resistant mutant Bcr-Abl *in vitro* and in murine models of leukemia. *Cancer Cell*; 7:129-141.
- 36 Weisberg E, Manley P, Mestan J, et al (2006) AMN107 (nilotinib): a novel and selective inhibitor of Bcr-Abl. *Br J Cancer*; advance on-line publication, doi: 10.1038/sj.bjc.6603170.

PART III: CONSUMER INFORMATION

PrTASIGNA[®] (Nilotinib Capsules)

50 mg, 150 mg and 200 mg nilotinib
(as nilotinib hydrochloride monohydrate)

This leaflet is part III of a three-part "Product Monograph" published when TASIGNA[®] was approved for sale in Canada and is designed specifically for Consumers. This leaflet is a summary and will not tell you everything about TASIGNA. Contact your doctor or pharmacist if you have any questions about the drug.

Read all of this leaflet carefully before you start taking this medicine.

Keep this leaflet. You may need to read it again.

ABOUT THIS MEDICATION

What the medication is used for:

TASIGNA is used to treat adults with:

- newly diagnosed Philadelphia chromosome positive chronic myeloid leukemia (Ph+ CML) in chronic phase.
- chronic phase and accelerated phase Ph+ CML who are no longer benefiting from other therapies for CML including imatinib.

TASIGNA is used to treat children and adolescents 2 years of age and older with:

- newly diagnosed Ph+ CML in chronic phase.
- chronic phase Ph+ CML who are no longer benefiting from other therapies for CML including imatinib.

What it does:

In patients with CML, a change in DNA (genetic material) triggers a signal that tells the body to produce abnormal white blood cells. TASIGNA blocks this signal to stop the production of these abnormal cells.

When it should not be used:

Do not use TASIGNA if you or your child:

- have an abnormal electrical signal of the heart (**prolongation of QT interval**),
- have uncorrectable low levels of potassium or magnesium,
- are **allergic** (hypersensitive) to nilotinib or any of the other ingredients of TASIGNA.

What the medicinal ingredient is:

Nilotinib.

What the important nonmedicinal ingredients are:

Colloidal silicon anhydrous, crospovidone, gelatin, iron oxide yellow, iron oxide red, lactose monohydrate, magnesium stearate, poloxamer, and titanium dioxide.

The 50 mg and 150 mg capsules also contain black iron oxide.

What dosage forms it comes in:

TASIGNA is supplied as a hard capsule, containing 50 mg, 150 mg or 200 mg nilotinib (as nilotinib hydrochloride monohydrate).

- The 50 mg capsules are red/yellow. A black imprint is stamped on each capsule ("NVR/ABL").
- The 150 mg capsules are red. A black imprint is stamped on each capsule ("NVR/BCR").
- The 200 mg capsules are light yellow. A red imprint is stamped on each capsule ("NVR/TKI").

TASIGNA is available in monthly packs:

- The monthly pack for 50 mg capsules contains 120 capsules divided into 3 blister-cartons of 40 capsules/carton.
- The monthly pack for 150 mg and 200 mg capsules contains 112 capsules divided into 4 individual weekly blister-packs.

WARNINGS AND PRECAUTIONS

Serious Warnings and Precautions:

TASIGNA should be given under the supervision of a doctor experienced in the use of anti-cancer drugs. Serious side effects with TASIGNA include:

- Sudden cardiac deaths,
- Prolongation of the QT interval (abnormal electrical signal of the heart),

- Ischemic heart disease (heart disorder), ischemic, cerebrovascular events (stroke or other problems due to decreased blood flow to the brain) and peripheral arterial occlusive disease (PAOD) (problems with decreased blood flow to your leg), rare fatal cases have been reported,
- Liver toxicity (increase of liver enzymes), fatal cases have been reported,
- Pancreatitis (inflammation of the pancreas),
- Myelosuppression (decrease of the production of blood cells).

TASIGNA is not to be used in patients who have uncorrectable low levels of potassium or magnesium.

TASIGNA should only be stopped under the supervision of a doctor experienced in the treatment of patients with CML.

BEFORE using TASIGNA talk to your doctor or pharmacist if you or your child:

- have a **heart disorder**, or a heart rhythm disorder (or a family history of heart rhythm disorder) such as an irregular heartbeat or an abnormal electrical signal of the heart called “prolongation of the QT interval”,
- have a personal history of fainting spells,
- have a family history of sudden cardiac death at age of less than 50 years,
- are being **treated with medicines** that affect the heart beat (antiarrhythmics) or medicines that may have an unwanted effect on the function of the heart (QT prolongation) (see also other drugs that may interact with TASIGNA under “INTERACTIONS WITH THIS MEDICATION”),
- have electrolyte problems (*e.g.*, low blood potassium levels) or conditions that could lead to electrolyte disturbances (*e.g.*, vomiting, diarrhea, dehydration),
- have an eating disorder or are following a strict diet,
- have diabetes, especially with associated nerve disorders,
- had a stroke or other problems due to decreased blood flow to the brain,
- have problems with decreased blood flow to your legs,
- have liver/kidney disease,
- have had pancreatitis (inflammation of the pancreas),
- have intolerance to lactose (milk sugar) or one of the following rare hereditary diseases:
 - Galactose intolerance
 - Lapp lactase deficiency
 - Glucose-galactose malabsorption.

This is because TASIGNA contains lactose.

- are pregnant or plan to get pregnant. TASIGNA is not recommended during pregnancy as it may harm the fetus. Women who can get pregnant must use highly effective birth control during treatment with TASIGNA and for at least 4 weeks after ending treatment,
- are a male patient and are concerned about your fertility (ability to father a child),
- are a sexually active male. Men who take TASIGNA must use highly effective birth control during treatment with TASIGNA, and for at least 4 weeks after ending treatment. Tell your doctor right away if your female partner becomes pregnant,
- are breast feeding or plan to breast feed. Women should not breast feed while taking TASIGNA and for two weeks after the last dose,
- have had a surgical procedure involving the removal of the entire stomach (total gastrectomy),
- have ever had or might now have a hepatitis B virus infection (a viral infection of the liver). This is because during treatment with TASIGNA, hepatitis B may become active again, which can be fatal in some cases. This is called hepatitis B reactivation. Your doctor will check for signs of this infection before and during treatment with TASIGNA.

TASIGNA can cause a possible life-threatening heart problem called QTc prolongation. QTc prolongation causes an irregular heart beat, which may uncommonly (0.17%) lead to sudden cardiac death. These heart rhythm disturbances are more likely in patients with risk factors, such as heart disease, or in the presence of certain interacting drugs. If you experience any symptoms of a possible heart rhythm disturbance, such as dizziness, palpitations (sensation of rapid, pounding, or irregular heart beat), fainting, or seizures, you should seek immediate medical attention.

Blood tests will also monitor the level of fatty substances (cholesterol and lipids) and sugar (glucose) in your blood.

TASIGNA is a treatment for adults, children and adolescents with CML. There is no experience with the use of TASIGNA in children below 2 years of age. The effects of treating children with TASIGNA for long periods of time are not known.

Children and adolescents may grow more slowly when taking TASIGNA. Your child’s doctor will measure their growth at regular visits.

Before and during the treatment with TASIGNA, certain blood tests will be done. These will monitor how TASIGNA is affecting your body. Electrocardiograms

(ECG) may also be done regularly. An ECG is a test that measures how well your heart is working.

TASIGNA may cause dizziness. DO NOT drive or use machines if you feel dizziness or are unable to see well while taking TASIGNA.

INTERACTIONS WITH THIS MEDICATION

Tell your doctor or pharmacist **before taking TASIGNA** if you or your child are taking or have recently taken any other medicines, including medicines obtained without a prescription. This includes in particular:

- antiarrhythmics such as amiodarone, disopyramide, procainamide, quinidine, sotalol, digoxin, ibutilide, flecainide, propafenone - used to treat irregular heart beat;
- verapamil - used to treat high blood pressure and some types of irregular heart beat;
- chloroquine, halofantrine, clarithromycin, haloperidol, moxifloxacin, methadone, bepridil, pimozide - medicines that may have an unwanted effect on the function of the heart (QT prolongation);
- laxatives, enemas, water pills, amphotericin B, high dose corticosteroids - medicines that can disturb electrolyte levels;
- chlorpromazine, droperidol, ziprasidone - used to stabilize thinking and behaviour;
- fluoxetine, citalopram, venlafaxine, tricyclic/tetracyclic antidepressants e.g. amitriptyline, imipramine, maprotiline – used to treat mood disorder;
- pentamidine – used to prevent and treat pneumocystis carinii pneumonia;
- chloroquine – used to treat malaria;
- vorinostat, sunitinib, lapatinib – used to treat cancers;
- salmeterol, formoterol – used to treat asthma;
- ketoconazole, itraconazole, voriconazole, levofloxacin, ciprofloxacin, fluconazole, erythromycin, clarithromycin, telithromycin, tacrolimus, cefazolin - used to treat infections;
- domperidone – used to treat gastrointestinal motility disorder;
- metoclopramide, prochlorperazine, ondansetron and dolasetron- used to treat nausea;
- ritonavir - an anti-HIV medicine from the class “antiproteases”;
- carbamazepine, phenobarbital, phenytoin - used to treat epilepsy;
- rifampicin - used to treat tuberculosis;
- St. John’s Wort - a herbal product (also known as *Hypericum Perforatum*);
- midazolam - used to relieve anxiety before surgery;

- warfarin - used to treat blood coagulation disorders (such as blood clots or thromboses);
- morphine, methadone - used to treat moderate to severe pain;
- buprenorphine- substitute treatment for opioids dependence;
- cyclosporine A- used to prevent organ transplantations rejections, and to treat autoimmune conditions;
- alfentanil and fentanyl - used to treat pain and used as a sedative before or during surgery or medical procedure;
- cyclosporine, sirolimus and tacrolimus - medicines that suppress the “self-defense” ability of the body and fight infections - commonly used to prevent the rejection of transplanted organs such as liver, heart and kidney;
- dihydroergotamine and ergotamine – used to treat dementia;
- levothyroxine– used to treat thyroid deficiency
- statins (such as simvastatin and lovastatin)- class of drugs used to treat high level of fats in blood.

In addition, while taking TASIGNA, speak with the doctor before taking antacids (medicines against heartburn). These medications need to be taken separately from TASIGNA:

- antacids called H2 blockers which suppress the production of acid in the stomach – should be taken approximately 10 hours before and approximately 2 hours after you take TASIGNA;
- antacids such as those containing aluminum hydroxide, magnesium hydroxide and simethicone which neutralize the high acidity of the stomach – should be taken approximately 2 hours before or approximately 2 hours after you take TASIGNA.

If the patient sees other doctors while taking TASIGNA, tell them about TASIGNA use.

Do not take TASIGNA with food. Taking TASIGNA with food may increase the amount of TASIGNA in the blood, possibly to a harmful level.

Do not take any products or juices containing grapefruit, star fruit, pomegranate, Seville oranges or similar fruits while taking TASIGNA. This may increase the amount of TASIGNA in blood, possibly to a harmful level.

PROPER USE OF THIS MEDICATION

Adults:

Always take TASIGNA exactly as your doctor has told you.

Newly diagnosed Ph+ CML in chronic phase:

- **Usual daily dose 600 mg:** take two 150 mg capsules two times a day, approximately every 12 hours.
- **Reduced daily dose 400 mg:** take two 200 mg capsules once a day.

Chronic phase and accelerated phase Ph+ CML in patients who are no longer benefitting from previous treatment for CML:

- **Usual daily dose 800 mg:** take two 200 mg capsules two times a day, approximately every 12 hours.
- **Reduced daily dose 400 mg:** take two 200 mg capsules once a day.

Children and adolescents

- Always give TASIGNA to your child exactly as the doctor has told you.
- Your child’s dose will depend on their body weight and height. The doctor will calculate the correct dose to use and tell you how many capsules of TASIGNA to give to your child.
- Your child’s dose of TASIGNA may change as your child grows.

Pediatric dosing of TASIGNA

Total Daily Dose	How to take this dose	
100 mg	Take one 50 mg capsule twice a day	Morning: 1 x 50 mg Evening: 1 x 50 mg
200 mg	Take two 50 mg capsules twice a day	Morning: 2 x 50 mg Evening: 2 x 50 mg
300 mg	Take one 150 mg capsule twice a day	Morning: 1 x 150 mg Evening: 1 x 150 mg
400 mg	Take one 200 mg capsule twice a day	Morning: 1 x 200 mg Evening: 1 x 200 mg
500 mg	Take one 50 mg and one 200 mg	Morning: 1 x 200 mg and 1 x 50 mg Evening: 1 x 200 mg

	capsule twice a day	and 1 x 50 mg
600 mg	Take two 150 mg capsules twice a day	Morning: 2 x 150 mg Evening: 2 x 150 mg
700 mg	Take one 200 mg and one 150 mg capsule twice a day	Morning: 1 x 200 mg and 1x150 mg Evening: 1 x 200 mg and 1 x150 mg
800 mg	Take two 200 mg capsules twice a day	Morning: 2 x 200 mg Evening: 2 x 200 mg

Swallow capsules whole with water on an empty stomach. Do not consume any food for at least 2 hours before the dose is taken and for at least 1 hour after the dose is taken. Do not open the capsules.

If capsules cannot be swallowed:

- **Open** the capsules
- **Mix** the content of each capsule in one teaspoon of applesauce (pureed apple)
Use **only one single teaspoon** of applesauce (not more).
Use **only applesauce** (no other food).

Swallow the mixture **immediately**.

Treatment Discontinuation:

The doctor may lower the dose, stop the treatment for a short time or discuss the option of stopping treatment completely. This may be based on a specific blood test result or if you or your child feels unwell.

If treatment with TASIGNA is stopped, the doctor will continue to carefully monitor your CML or that of your child. The doctor may tell you or your child to re-start TASIGNA if the condition requires it.

Overdose:

If you or your child have taken more TASIGNA than directed, or if someone else accidentally takes the capsules, contact your doctor or the nearest hospital emergency room or a local poison control centre immediately. You may be asked to show them the pack of capsules.

Missed Dose:

If a dose is missed, take the next dose as scheduled. Do not take a double dose to make up for the forgotten capsules.

SIDE EFFECTS AND WHAT TO DO ABOUT THEM

As with all medicines, TASIGNA can cause side effects. These are not all the possible side effects that may be experienced when taking TASIGNA. If any side effects not listed here are experienced, or these affect you or your child severely, tell your doctor or pharmacist.

- fatigue;
- weakness;
- muscle pain;
- itching;
- hair loss;
- upper respiratory tract infections;
- dyspepsia (digestion problems), eating disorder (anorexia), disturbed sense of taste;
- skin reddening;
- insomnia, depression, anxiety.

Call your doctor as soon as possible if you faint (loss of consciousness) or have an irregular heartbeat while taking TASIGNA as these may be due to a serious heart condition.

If you are the caregiver of a child who is being treated with TASIGNA, tell the doctor if any of the above conditions apply to your child.

SERIOUS SIDE EFFECTS, HOW OFTEN THEY HAPPEN AND WHAT TO DO ABOUT THEM

Symptom / effect		Talk with your doctor or pharmacist		Stop taking drug and call your doctor or pharmacist
		Only if severe	In all cases	
Very Common or Common	Changes in blood test results: Chills, fever, easy bruising, frequent infections, fatigue		✓	
	High levels of bilirubin in the blood: Yellow skin and eyes, pale stool, dark urine,		✓	

SERIOUS SIDE EFFECTS, HOW OFTEN THEY HAPPEN AND WHAT TO DO ABOUT THEM

Symptom / effect	Talk with your doctor or pharmacist		Stop taking drug and call your doctor or pharmacist
	Only if severe	In all cases	
loss of appetite, fatigue			
Nausea	✓		
Common		✓	
Parasthesia: Sensation of tingling, pain or numbness in fingers and toes		✓	
Heart Disorders: Chest pain, or discomfort, high blood pressure, irregular heart rhythm blue discoloration of the lips, tongue or skin		✓	
Heart failure: Chest pain, irregular heart rhythm (fast or slow)		✓	
Prolongation of QT interval: Irregular heartbeat, fainting, loss of consciousness		✓	
Abdominal pain	✓		
Fever	✓		
Lung Disorders: Difficulty breathing or painful, cough, wheezing with or without fever		✓	
Inflammation of the pancreas (pancreatitis): Severe upper (middle or left) abdominal pain		✓	
Growth Retardation: (when a child is not growing at a		✓	

SERIOUS SIDE EFFECTS, HOW OFTEN THEY HAPPEN AND WHAT TO DO ABOUT THEM				
Symptom / effect		Talk with your doctor or pharmacist		Stop taking drug and call your doctor or pharmacist
		Only if severe	In all cases	
	normal rate for their age)			
Common or uncommon	Water retention: Rapid weight gain, swelling of hands, ankles, feet or face		✓	
	High blood sugar: Excessive thirst, high urine output, increased appetite with weight loss, tiredness		✓	
Uncommon	Liver Damage: Yellow skin and eyes, nausea, loss of appetite, dark-colored urine		✓	
	Diarrhea	✓		
	Vomiting	✓		
	Gastrointestinal disorders: Abdominal pain, nausea, vomiting of blood, black stools, constipation, heartburn, swelling or bloating of the abdomen		✓	
	Blocked artery in leg, arm, finger or toe: pain or discomfort, weakness, or cramping in leg muscles which may be due to decreased blood flow, ulcers that heal slowly or not at all and noticeable changes in color (blueness or paleness) or temperature (coolness)		✓	
	Generally feeling	✓		

SERIOUS SIDE EFFECTS, HOW OFTEN THEY HAPPEN AND WHAT TO DO ABOUT THEM				
Symptom / effect		Talk with your doctor or pharmacist		Stop taking drug and call your doctor or pharmacist
		Only if severe	In all cases	
	unwell			
	Bone pain		✓	
	Pain in joints		✓	
	Urinary tract disorders: Difficulty and pain when passing urine, exaggerated sense of needing to urinate, blood in urine		✓	
	Overactive thyroid gland (hyperthyroid): Fast heart beat, bulging eyes, weight loss, swelling at front of the neck		✓	
	Low levels of growth hormone (growth hormone deficiency): growing more slowly, short stature, weight gain especially around the body, changes in muscle mass, changes in mood, delay in start of puberty	✓		
	Migraine: Severe headache often accompanied by nausea, vomiting and sensitivity to light		✓	
Uncommon or Unknown Frequency	Nervous system disorders (such as bleeding in the skull): Weakness or paralysis of limbs or face, difficulty speaking, severe headache, seeing, feeling or hearing		✓	

SERIOUS SIDE EFFECTS, HOW OFTEN THEY HAPPEN AND WHAT TO DO ABOUT THEM				
Symptom / effect		Talk with your doctor or pharmacist		Stop taking drug and call your doctor or pharmacist
		Only if severe	In all cases	
	things that are not there, loss of consciousness, confusion, disorientation, trembling			
	Kidney disorders (including kidney failure): Thirst, dry skin, irritability, dark urine, decreased urine output		✓	
	Eye disorders: Blurred vision, loss of vision in eye, increased sensitivity of the eyes to light, eye pain or redness, swelling and itching of the eyelids, decreased sharpness of vision, eye irritation		✓	
	Skin disorders: Rash, painful red lumps, pain in joints and muscles		✓	
	Underactive thyroid gland (hypothyroid): Weight gain, tiredness, hair loss, muscle weakness, feeling cold		✓	
Unknown Frequency	Rhabdomyolysis (breakdown of damaged muscle): Muscle spasms, fever, red-brown urine		✓	

SERIOUS SIDE EFFECTS, HOW OFTEN THEY HAPPEN AND WHAT TO DO ABOUT THEM				
Symptom / effect		Talk with your doctor or pharmacist		Stop taking drug and call your doctor or pharmacist
		Only if severe	In all cases	
	Blood clot in a vein: Swelling and pain in one part of the body		✓	
	Low blood pressure: Dizziness, spinning, sensation		✓	
	Second malignancies (such as gastric cancer, gastrointestinal stromal tumour, pancreatic carcinoma, pancreatic neuroendocrine tumour, colon cancer)		✓	
	Tumour lysis syndrome (the sudden, rapid death of cancer cells due to the treatment): Nausea, shortness of breath, irregular heartbeat, clouding of urine, tiredness and/or joint pain		✓	
	Hepatitis B reactivation (a previous viral infection of the liver becomes active again): fever, skin rash, joint pain and inflammation as well as tiredness, loss of appetite, nausea, jaundice (yellowing of the skin or whites of eyes), pain in the upper right abdomen, pale stools and dark		✓	

SERIOUS SIDE EFFECTS, HOW OFTEN THEY HAPPEN AND WHAT TO DO ABOUT THEM

Symptom / effect	Talk with your doctor or pharmacist		Stop taking drug and call your doctor or pharmacist
	Only if severe	In all cases	
urine. Hepatitis B reactivation can be fatal in some cases			
Reported from post-marketing with Unknown Frequency	Severe allergic reaction: Rash, hives, swelling of the face, lips tongue or throat, difficulty swallowing or breathing, dizziness		✓
	Cardiac tamponade: Anxiety, restlessness, chest pain		✓
	Bronchospasm: Difficulty breathing with wheezing or coughing		✓
	Abnormal laboratory values: Nausea, shortness of breath, irregular heartbeat, clouding of urine, tiredness and/or joint discomfort associated with blood test results (such as high potassium, uric acid, and phosphorous levels and low calcium levels in the blood)		✓
Spontaneous abortions, stillbirth and fetal malformations.		✓	

This is not a complete list of side effects. For any unexpected effects while taking TASIGNA, contact your doctor or pharmacist.

- Keep out of the reach and sight of children.
- Do not use TASIGNA after the expiry date which is stated on the carton after EXP. The expiry date refers to the last day of that month.
- Store at room temperature (15-30°C).
- Store in the original package.

REPORTING SUSPECTED SIDE EFFECTS

You can report any suspected adverse reactions associated with the use of health products to the Canada Vigilance Program by one of the following 3 ways:

Report online at www.healthcanada.gc.ca/medeffect
 Call toll-free at 1-866-234-2345
 Complete a Canada Vigilance Reporting Form and:
 - Fax toll-free to 1-866-678-6789, or
 - Mail to: **Canada Vigilance Program**
Health Canada
Postal Locator 0701D
Ottawa, Ontario
K1A 0K9

Postage paid labels, Canada Vigilance Reporting Form and the adverse reaction reporting guidelines are available on the MedEffect™ Canada Web site at www.healthcanada.gc.ca/medeffect.

NOTE: Should you require information related to the management of side effects, contact your health professional. The Canada Vigilance Program does not provide medical advice.

MORE INFORMATION

Please consult the doctor or pharmacist with any questions or concerns you may have regarding your individual condition.

This document plus the full product monograph, prepared for health professionals can be found at: <http://www.novartis.ca> or by contacting the sponsor Novartis Pharmaceuticals Canada Inc., at: 1-800-363-8883

This leaflet was prepared by Novartis Pharmaceuticals Canada Inc. 385, Bouchard Blvd. Dorval, Quebec, H9S 1A9

Last revised: March 13, 2020

TASIGNA (nilotinib capsules) is a registered trademark.

HOW TO STORE IT

HIGHLIGHTS OF PRESCRIBING INFORMATION

These highlights do not include all the information needed to use TASIGNA safely and effectively. See full prescribing information for TASIGNA.

TASIGNA® (nilotinib) capsules, for oral use
Initial U.S. Approval: 2007

WARNING: QT PROLONGATION AND SUDDEN DEATHS

See full prescribing information for complete boxed warning.

- Tasigna prolongs the QT interval. Prior to Tasigna administration and periodically, monitor for hypokalemia or hypomagnesemia and correct deficiencies (5.2). Obtain ECGs to monitor the QTc at baseline, seven days after initiation, and periodically thereafter, and following any dose adjustments (5.2, 5.3, 5.7, 5.12).
- Sudden deaths have been reported in patients receiving Tasigna (5.3). Do not administer Tasigna to patients with hypokalemia, hypomagnesemia, or long QT syndrome (4, 5.2).
- Avoid use of concomitant drugs known to prolong the QT interval and strong CYP3A4 inhibitors (7.1, 7.2).
- Avoid food 2 hours before and 1 hour after taking the dose (2.1).

RECENT MAJOR CHANGES

Warnings and Precautions, Adverse Growth and Development (5.14) 9/2019

INDICATIONS AND USAGE

Tasigna is a kinase inhibitor indicated for the treatment of:

- Adult and pediatric patients greater than or equal to 1 year of age with newly diagnosed Philadelphia chromosome positive chronic myeloid leukemia (Ph+ CML) in chronic phase. (1.1)
- Adult patients with chronic phase (CP) and accelerated phase (AP) Ph+ CML resistant to or intolerant to prior therapy that included imatinib. (1.2)
- Pediatric patients greater than or equal to 1 year of age with Ph+ CML-CP resistant or intolerant to prior tyrosine-kinase inhibitor (TKI) therapy. (1.3)

DOSAGE AND ADMINISTRATION

- Recommended Adult Dose: Newly diagnosed Ph+ CML-CP: 300 mg orally twice daily. Resistant or intolerant Ph+ CML-CP and CML-AP: 400 mg orally twice daily. (2.1)
- Recommended Pediatric Dose: Newly Diagnosed Ph+ CML-CP or Ph+ CML-CP resistant or intolerant to prior TKI therapy: 230 mg/m² orally twice daily, rounded to the nearest 50 mg dose (to a maximum single dose of 400 mg). (2.1)
- See Dosage and Administration (2.1) for full dosing instructions and dose-reduction instructions for toxicity.
- Reduce starting dose in patients with baseline hepatic impairment. (2.7)
- Eligible newly diagnosed adult patients with Ph+ CML-CP who have received Tasigna for a minimum of 3 years and have achieved a sustained molecular response (MR4.5) and patients with Ph+ CML-CP resistant or intolerant to imatinib who have received Tasigna for at least 3 years and have achieved a sustained molecular response (MR4.5) may be considered for treatment discontinuation. (2.2, 2.3, 5.16)

DOSAGE FORMS AND STRENGTHS

Capsules: 50 mg, 150 mg, and 200 mg (3)

CONTRAINDICATIONS

Tasigna is contraindicated in patients with hypokalemia, hypomagnesemia, or long QT syndrome. (4)

WARNINGS AND PRECAUTIONS

- **Myelosuppression:** Monitor complete blood count (CBC) during therapy and manage by treatment interruption or dose-reduction. (5.1)
- **Cardiac and Arterial Vascular Occlusive Events:** Evaluate cardiovascular status, monitor and manage cardiovascular risk factors during Tasigna therapy. (5.4)
- **Pancreatitis and Elevated Serum Lipase:** Monitor serum lipase; if elevations are accompanied by abdominal symptoms, interrupt doses and consider appropriate diagnostics to exclude pancreatitis. (5.5)
- **Hepatotoxicity:** Monitor hepatic function tests monthly or as clinically indicated. (5.6)
- **Electrolyte Abnormalities:** Tasigna can cause hypophosphatemia, hypokalemia, hyperkalemia, hypocalcemia, and hyponatremia. Correct electrolyte abnormalities prior to initiating Tasigna and monitor periodically during therapy. (5.7)
- **Tumor Lysis Syndrome:** Maintain adequate hydration and correct uric acid levels prior to initiating therapy with Tasigna. (5.8)
- **Hemorrhage:** Hemorrhage from any site may occur. Advise patients to report signs and symptoms of bleeding and medically manage as needed. (5.9)
- **Fluid Retention:** Monitor patients for unexpected rapid weight gain, swelling, and shortness of breath. Manage medically. (5.13)
- **Effects on Growth and Development in Pediatric Patients:** Growth retardation has been reported in pediatric patients treated with Tasigna. Monitor growth and development in pediatric patients. (5.14)
- **Embryo-Fetal Toxicity:** Advise patients of potential risk to a fetus and to use effective contraception. (5.15, 8.1, 8.3)
- **Treatment Discontinuation:** Patients must have typical BCR-ABL transcripts. An FDA-authorized test with a detection limit below MR4.5 must be used to determine eligibility for discontinuation. Patients must be frequently monitored by the FDA authorized test to detect possible loss of remission. (5.16)

ADVERSE REACTIONS

The most commonly reported non-hematologic adverse reactions (≥ 20%) in adult and pediatric patients were nausea, rash, headache, fatigue, pruritus, vomiting, diarrhea, cough, constipation, arthralgia, nasopharyngitis, pyrexia, and night sweats. Hematologic adverse drug reactions include myelosuppression: thrombocytopenia, neutropenia, and anemia. (6.1)

To report SUSPECTED ADVERSE REACTIONS, contact Novartis Pharmaceuticals Corporation at 1-888-669-6682 or FDA at 1-800-FDA-1088 or www.fda.gov/medwatch.

DRUG INTERACTIONS

- **Strong CYP3A Inhibitors:** Avoid concomitant use with Tasigna, or reduce Tasigna dose if co-administration cannot be avoided. (7.1)
- **Strong CYP3A Inducers:** Avoid concomitant use with Tasigna. (7.1)
- **Proton Pump Inhibitors:** Use short-acting antacids or H2 blockers as an alternative to proton pump inhibitors (7.1)

USE IN SPECIFIC POPULATIONS

- Lactation: Advise women not to breastfeed. (8.2)

See 17 for PATIENT COUNSELING INFORMATION and Medication Guide.

Revised: 9/2019

FULL PRESCRIBING INFORMATION: CONTENTS*
WARNING: QT PROLONGATION AND SUDDEN DEATHS

1 INDICATIONS AND USAGE

- 1.1 Adult and Pediatric Patients with Newly Diagnosed Ph+ CML-CP
- 1.2 Adult Patients with Resistant or Intolerant Ph+ CML-CP and CML-AP
- 1.3 Pediatric Patients with Resistant or Intolerant Ph+ CML-CP

2 DOSAGE AND ADMINISTRATION

- 2.1 Recommended Dosing
- 2.2 Discontinuation of treatment after a sustained molecular response (MR4.5) on Tasigna
- 2.3 Reinitiation of treatment in patients who lose molecular response after discontinuation of therapy with Tasigna.
- 2.4 Dosage Modification for QT Interval Prolongation
- 2.5 Dosage Modifications for Myelosuppression
- 2.6 Dosage Modification for Other Non-Hematologic Toxicities
- 2.7 Dosage Modification for Hepatic Impairment
- 2.8 Dosage Modification with Concomitant Strong CYP3A4 Inhibitors

3 DOSAGE FORMS AND STRENGTHS

4 CONTRAINDICATIONS

5 WARNINGS AND PRECAUTIONS

- 5.1 Myelosuppression
- 5.2 QT Prolongation
- 5.3 Sudden Deaths
- 5.4 Cardiac and Arterial Vascular Occlusive Events
- 5.5 Pancreatitis and Elevated Serum Lipase
- 5.6 Hepatotoxicity
- 5.7 Electrolyte Abnormalities
- 5.8 Tumor Lysis Syndrome
- 5.9 Hemorrhage
- 5.10 Total Gastrectomy
- 5.11 Lactose
- 5.12 Monitoring Laboratory Tests
- 5.13 Fluid Retention
- 5.14 Effects on Growth and Development in Pediatric Patients
- 5.15 Embryo-Fetal Toxicity
- 5.16 Monitoring of BCR-ABL Transcript Levels

6 ADVERSE REACTIONS

- 6.1 Clinical Trials Experience
- 6.2 Postmarketing Experience

7 DRUG INTERACTIONS

- 7.1 Effect of Other Drugs on Tasigna
- 7.2 Drugs that Prolong the QT Interval

8 USE IN SPECIFIC POPULATIONS

- 8.1 Pregnancy
- 8.2 Lactation
- 8.3 Females and Males of Reproductive Potential
- 8.4 Pediatric Use
- 8.5 Geriatric Use
- 8.6 Cardiac Disorders
- 8.7 Hepatic Impairment

10 OVERDOSAGE

11 DESCRIPTION

12 CLINICAL PHARMACOLOGY

- 12.1 Mechanism of Action
- 12.2 Pharmacodynamics
- 12.3 Pharmacokinetics
- 12.5 Pharmacogenomics

13 NONCLINICAL TOXICOLOGY

- 13.1 Carcinogenesis, Mutagenesis, Impairment of Fertility

14 CLINICAL STUDIES

- 14.1 Adult Newly Diagnosed Ph+ CML-CP
- 14.2 Adult Patients with Resistant or Intolerant Ph+ CML-CP and CML-AP
- 14.3 Treatment discontinuation in newly diagnosed Ph+ CML-CP patients who have achieved a sustained molecular response (MR4.5)
- 14.4 Treatment discontinuation in Ph+ CML-CP patients who have achieved a sustained molecular response (MR4.5) on Tasigna following prior imatinib therapy
- 14.5 Pediatric Patients with Newly Diagnosed Ph+ CML-CP or Resistant or Intolerant Ph+ CML-CP

16 HOW SUPPLIED/STORAGE AND HANDLING

17 PATIENT COUNSELING INFORMATION

* Sections or subsections omitted from the full prescribing information are not listed

FULL PRESCRIBING INFORMATION

WARNING: QT PROLONGATION AND SUDDEN DEATHS

- **Tasigna prolongs the QT interval. Prior to Tasigna administration and periodically, monitor for hypokalemia or hypomagnesemia and correct deficiencies [see Warnings and Precautions (5.2)]. Obtain ECGs to monitor the QTc at baseline, seven days after initiation, and periodically thereafter, and following any dose adjustments [see Warnings and Precautions (5.2, 5.3, 5.7, 5.12)].**
- **Sudden deaths have been reported in patients receiving Tasigna [see Warnings and Precautions (5.3)]. Do not administer Tasigna to patients with hypokalemia, hypomagnesemia, or long QT syndrome [see Contraindications (4), Warnings and Precautions (5.2)].**
- **Avoid use of concomitant drugs known to prolong the QT interval and strong CYP3A4 inhibitors [see Drug Interactions (7.1, 7.2)].**
- **Avoid food 2 hours before and 1 hour after taking the dose [see Dosage and Administration (2.1)].**

1 INDICATIONS AND USAGE

1.1 Adult and Pediatric Patients with Newly Diagnosed Ph+ CML-CP

Tasigna is indicated for the treatment of adult and pediatric patients greater than or equal to 1 year of age with newly diagnosed Philadelphia chromosome positive chronic myeloid leukemia (Ph+ CML) in chronic phase.

1.2 Adult Patients with Resistant or Intolerant Ph+ CML-CP and CML-AP

Tasigna is indicated for the treatment of adult patients with chronic phase and accelerated phase Philadelphia chromosome positive chronic myelogenous leukemia (Ph+ CML) resistant or intolerant to prior therapy that included imatinib.

1.3 Pediatric Patients with Resistant or Intolerant Ph+ CML-CP

Tasigna is indicated for the treatment of pediatric patients greater than or equal to 1 year of age with chronic phase Philadelphia chromosome positive chronic myeloid leukemia (Ph+ CML) with resistance or intolerance to prior tyrosine-kinase inhibitor (TKI) therapy.

2 DOSAGE AND ADMINISTRATION

2.1 Recommended Dosage

Dose Tasigna twice daily at approximately 12-hour intervals on an empty stomach. No food should be consumed for at least 2 hours before the dose is taken and for at least 1 hour after the dose is taken. Advise patients to swallow the capsules whole with water [see Boxed Warning, Clinical Pharmacology (12.3)].

For patients who are unable to swallow capsules, the contents of each capsule may be dispersed in 1 teaspoon of applesauce (puréed apple). The mixture should be taken immediately (within 15 minutes) and should not be stored for future use [see Clinical Pharmacology (12.3)].

Tasigna may be given in combination with hematopoietic growth factors such as erythropoietin or G-CSF if clinically indicated. Tasigna may be given with hydroxyurea or anagrelide if clinically indicated.

Dosage in Adult Patients with Newly Diagnosed Ph+ CML-CP

The recommended dosage of Tasigna is 300 mg orally twice daily.

Dosage in Adult Patients with Resistant or Intolerant Ph+ CML-CP and CML-AP

The recommended dosage of Tasigna is 400 mg orally twice daily.

Dosage in Pediatric Patients with Newly Diagnosed Ph+ CML-CP or Resistant or Intolerant Ph+ CML-CP

The recommended dosage of Tasigna for pediatric patients is 230 mg/m² orally twice daily, rounded to the nearest 50 mg dose (to a maximum single dose of 400 mg) (see Table 1). If needed, attain the desired dose by

combining different strengths of Tasigna capsules. Continue treatment as long as clinical benefit is observed or until unacceptable toxicity occurs.

Table 1: Pediatric dosing of Tasigna (230 mg/m² twice daily, maximum single dose of 400 mg)

Body Surface Area	Single Dose	Total Daily Dose
Up to 0.32 m ²	50 mg	100 mg
0.33–0.54 m ²	100 mg	200 mg
0.55–0.76 m ²	150 mg	300 mg
0.77–0.97 m ²	200 mg	400 mg
0.98–1.19 m ²	250 mg	500 mg
1.20–1.41 m ²	300 mg	600 mg
1.42–1.63 m ²	350 mg	700 mg
≥ 1.64 m ²	400 mg	800 mg

2.2 Discontinuation of treatment after a sustained molecular response (MR4.5) on Tasigna

Patient Selection

Eligibility for Discontinuation of Treatment

Ph⁺ CML-CP patients with typical BCR-ABL transcripts who have been taking Tasigna for a minimum of 3 years and have achieved a sustained molecular response (MR4.5, corresponding to = BCR-ABL/ABL ≤ 0.0032% IS) may be eligible for treatment discontinuation [see *Clinical Studies (14.3, 14.4)*]. Information on FDA authorized tests for the detection and quantitation of BCR-ABL transcripts to determine eligibility for treatment discontinuation is available at <http://www.fda.gov/CompanionDiagnostics>.

Patients with typical BCR-ABL transcripts (e13a2/b2a2 or e14a2/b3a2) who achieve the sustained MR4.5 criteria are eligible for discontinuation of Tasigna treatment. Patients must continue to be monitored for possible loss of molecular remission after treatment discontinuation. Use the same FDA authorized test to consistently monitor molecular response levels while on and off treatment.

Consider discontinuation of treatment in patients with newly diagnosed Ph⁺ CML-CP who have:

- been treated with Tasigna for at least 3 years
- maintained a molecular response of at least MR4.0 (corresponding to = BCR-ABL/ABL ≤ 0.01% IS) for one year prior to discontinuation of therapy
- achieved an MR4.5 for the last assessment taken immediately prior to discontinuation of therapy
- been confirmed to express the typical BCR-ABL transcripts (e13a2/b2a2 or e14a2/b3a2)
- no history of accelerated phase or blast crisis
- no history of prior attempts of treatment-free remission discontinuation that resulted in relapse.

Consider discontinuation of treatment in patients with Ph⁺ CML-CP that are resistant or intolerant to treatment with imatinib who have achieved a sustained molecular response (MR4.5) on Tasigna who have:

- been treated with Tasigna for a minimum of 3 years
- been treated with imatinib only prior to treatment with Tasigna
- achieved a molecular response of MR4.5 (corresponding to = BCR-ABL/ABL ≤ 0.0032% IS)
- sustained an MR4.5 for a minimum of one year immediately prior to discontinuation of therapy
- been confirmed to express the typical BCR-ABL transcripts (e13a2/b2a2 or e14a2/b3a2)

- no history of accelerated phase or blast crisis
- no history of prior attempts of treatment-free remission discontinuation that resulted in relapse.

Monitor BCR-ABL transcript levels and complete blood count with differential in patients who have discontinued Tasigna therapy monthly for one year, then every 6 weeks for the second year, and every 12 weeks thereafter [see *Warnings and Precautions (5.16)*].

Upon the loss of MR4.0 (corresponding to $= \text{BCR-ABL/ABL} \leq 0.01\% \text{IS}$) during the treatment-free phase, monitor BCR-ABL transcript levels every 2 weeks until BCR-ABL levels remain lower than major molecular response (MMR, corresponding to MR3.0 or $= \text{BCR-ABL/ABL} \leq 0.1\% \text{IS}$) for 4 consecutive measurements. The patient can then proceed to the original monitoring schedule.

2.3 Reinitiation of treatment in patients who lose molecular response after discontinuation of therapy with Tasigna.

- Newly diagnosed patients who lose MMR must reinitiate treatment within 4 weeks at the dose level prior to discontinuation of therapy [see *Warnings and Precautions (5.16)*]. Patients who reinitiate Tasigna therapy should have their BCR-ABL transcript levels monitored monthly until major molecular response is re-established and every 12 weeks thereafter.
- Patients resistant or intolerant to prior treatment that included imatinib with confirmed loss of MR4.0 (2 consecutive measures separated by at least 4 weeks showing loss of MR4.0) or loss of MMR must reinitiate treatment within 4 weeks at the dose level prior to discontinuation of therapy [see *Warnings and Precautions (5.16)*]. Patients who reinitiate Tasigna therapy should have their BCR-ABL transcript levels monitored monthly until previous major molecular response or MR4.0 is re-established and every 12 weeks thereafter.

2.4 Dosage Modification for QT Interval Prolongation

See Table 2 for dose adjustments for QT interval prolongation [see *Clinical Pharmacology (12.2)*].

Table 2: Dose Adjustments for Adult and Pediatric Patients with QT Prolongation

Degree of QTc Prolongation	Dose Adjustment
ECGs with a QTc greater than 480 msec	<ol style="list-style-type: none"> 1. Withhold Tasigna, and perform an analysis of serum potassium and magnesium, and if below lower limit of normal, correct with supplements to within normal limits. Concomitant medication usage must be reviewed. 2. Resume within 2 weeks at prior dose if QTcF returns to less than 450 msec and to within 20 msec of baseline. 3. If QTcF is between 450 msec and 480 msec after 2 weeks, reduce the dose to 400 mg once daily in adults and 230 mg/m² once daily in pediatric patients. 4. Discontinue Tasigna if, following dose-reduction to 400 mg once daily in adults and 230 mg/m² once daily in pediatric patients, QTcF returns to greater than 480 msec. 5. An ECG should be repeated approximately 7 days after any dose adjustment.

2.5 Dosage Modifications for Myelosuppression

Withhold or reduce Tasigna dosage for hematological toxicities (neutropenia, thrombocytopenia) that are not related to underlying leukemia (Table 3).

Table 3: Dose Adjustments for Neutropenia and Thrombocytopenia

Diagnosis	Degree of Myelosuppression	Dose Adjustment
Adult patients with: - Newly diagnosed Ph+ CML in chronic phase at 300 mg twice daily - Resistant or intolerant Ph+ CML in chronic phase or accelerated phase at 400 mg twice daily	ANC* less than $1.0 \times 10^9/L$ and/or platelet counts less than $50 \times 10^9/L$	<ol style="list-style-type: none"> 1. Stop Tasigna, and monitor blood counts 2. Resume within 2 weeks at prior dose if ANC greater than $1.0 \times 10^9/L$ and platelets greater than $50 \times 10^9/L$ 3. If blood counts remain low for greater than 2 weeks, reduce the dose to 400 mg once daily
Pediatric patients with: - Newly diagnosed Ph+ CML in chronic phase at $230 \text{ mg}/\text{m}^2$ twice daily - Resistant or intolerant Ph+ CML in chronic phase at $230 \text{ mg}/\text{m}^2$ twice daily	ANC* less than $1.0 \times 10^9/L$ and/or platelet counts less than $50 \times 10^9/L$	<ol style="list-style-type: none"> 1. Stop Tasigna and monitor blood counts 2. Resume within 2 weeks at prior dose if ANC greater than $1.5 \times 10^9/L$ and/or platelets greater than $75 \times 10^9/L$ 3. If blood counts remain low for greater than 2 weeks, a dose reduction to $230 \text{ mg}/\text{m}^2$ once daily may be required 4. If event occurs after dose reduction, consider discontinuing treatment

*ANC = absolute neutrophil count.

See Table 4 for dose adjustments for elevations of lipase, amylase, bilirubin, and/or hepatic transaminases [see *Adverse Reactions (6.1)*].

Table 4: Dose Adjustments for Selected Non-Hematologic Laboratory Abnormalities

Degree of Non-Hematologic Laboratory Abnormalities	Dose Adjustment
Elevated serum lipase or amylase greater than or equal to Grade 3	Adult patients: 1. Withhold Tasigna, and monitor serum lipase or amylase 2. Resume treatment at 400 mg once daily if serum lipase or amylase returns to less than or equal to Grade 1
	Pediatric patients: 1. Interrupt Tasigna until the event returns to less than or equal to Grade 1 2. Resume treatment at 230 mg/m ² once daily if prior dose was 230 mg/m ² twice daily; discontinue treatment if prior dose was 230 mg/m ² once daily
Elevated bilirubin greater than or equal to Grade 3 in adult patients and greater than or equal to Grade 2 in pediatric patients	Adult patients: 1. Withhold Tasigna, and monitor bilirubin 2. Resume treatment at 400 mg once daily if bilirubin returns to less than or equal to Grade 1
	Pediatric patients: 1. Interrupt Tasigna until the event returns to less than or equal to Grade 1 2. Resume treatment at 230 mg/m ² once daily if prior dose was 230 mg/m ² twice daily; discontinue treatment if prior dose was 230 mg/m ² once daily, and recovery to less than or equal to Grade 1 takes longer than 28 days
Elevated hepatic transaminases greater than or equal to Grade 3	Adult patients: 1. Withhold Tasigna, and monitor hepatic transaminases 2. Resume treatment at 400 mg once daily if hepatic transaminases returns to less than or equal to Grade 1
	Pediatric patients: 1. Interrupt Tasigna until the event returns to less than or equal to Grade 1 2. Resume treatment at 230 mg/m ² once daily if prior dose was 230 mg/m ² twice daily; discontinue treatment if prior dose was 230 mg/m ² once daily, and recovery to less than or equal to Grade 1 takes longer than 28 days

2.6 Dosage Modification for Other Non-Hematologic Toxicities

If clinically significant moderate or severe non-hematologic toxicity develops (including medically severe fluid retention), see Table 5 for dose adjustments [*see Adverse Reactions (6.1)*].

Table 5: Dose Adjustments for Other Non-hematologic Laboratory Abnormalities

Degree of “Other Non-Hematologic Toxicity”	Dose Adjustment
Other clinically moderate or severe non-hematologic toxicity	<p>Adult patients:</p> <ol style="list-style-type: none"> 1. Withhold Tasigna until toxicity has resolved. 2. Resume treatment at 400 mg once daily if previous dose was 300 mg twice daily in adult patients newly diagnosed with CML-CP or 400 mg twice daily in adult patients with resistant or intolerant CML-CP and CML-AP. 3. Discontinue treatment if the prior dose was 400 mg once daily in adult patients. 4. If clinically appropriate, consider re-escalation of the dose to 300 mg (newly diagnosed Ph+ CML-CP) or 400 mg (resistant or intolerant Ph+ CML-CP and CML-AP) twice daily.
	<p>Pediatric patients:</p> <ol style="list-style-type: none"> 1. Interrupt Tasigna until toxicity has resolved. 2. Resume treatment at 230 mg/m² once daily if previous dose was 230 mg/m² twice daily; discontinue treatment if prior dose was 230 mg/m² once daily. 3. If clinically appropriate, consider re-escalation of the dose to 230 mg/m² twice daily.

2.7 Dosage Modification for Hepatic Impairment

If possible, consider alternative therapies. If Tasigna must be administered to patients with hepatic impairment, consider the following dose reduction:

Table 6: Dose Adjustments for Adult Patients with Hepatic Impairment

Diagnosis	Degree of Hepatic Impairment	Dosage Adjustment
Newly diagnosed Ph+ CML in chronic phase	Mild (Child-Pugh A), Moderate (Child-Pugh B), or Severe (Child-Pugh C)	Reduce dosage to 200 mg twice daily. Increase dosage to 300 mg twice daily based on tolerability.
Resistant or intolerant Ph+ CML in chronic phase or accelerated phase	Mild or Moderate	Reduce dosage to 300 mg twice daily. Increase dosage to 400 mg twice daily based on tolerability.
	Severe	Reduce dosage to 200 mg twice daily. Increase dosage to 300 mg twice daily and then to 400 mg twice daily based on tolerability.

[see Use in Specific Populations (8.7)].

2.8 Dosage Modification with Concomitant Strong CYP3A4 Inhibitors

Avoid the concomitant use of strong CYP3A4 inhibitors. Should treatment with any of these agents be required, interrupt therapy with Tasigna. If patients must be coadministered a strong CYP3A4 inhibitor, reduce dosage to 300 mg once daily in patients with resistant or intolerant Ph+ CML or to 200 mg once daily in patients with newly diagnosed Ph+ CML-CP. However, there are no clinical data with this dose adjustment in patients receiving strong CYP3A4 inhibitors. If the strong inhibitor is discontinued, allow a washout period before adjusting Tasigna dose upward to the indicated dose. For patients who cannot avoid use of strong CYP3A4

inhibitors, monitor closely for prolongation of the QT interval [see *Boxed Warning, Warnings and Precautions (5.2), Drug Interactions (7.1, 7.2), and Clinical Pharmacology (12.3)*].

3 DOSAGE FORMS AND STRENGTHS

50 mg red opaque cap and light-yellow opaque body hard gelatin capsules with black radial imprint “NVR/ABL.”

150 mg red opaque hard gelatin capsules with black axial imprint “NVR/BCR.”

200 mg light-yellow opaque hard gelatin capsules with a red axial imprint “NVR/TKI.”

4 CONTRAINDICATIONS

Tasigna is contraindicated in patients with hypokalemia, hypomagnesemia, or long QT syndrome [see *Boxed Warning*].

5 WARNINGS AND PRECAUTIONS

5.1 Myelosuppression

Treatment with Tasigna can cause Grade 3/4 thrombocytopenia, neutropenia, and anemia. Perform complete blood counts (CBCs) every 2 weeks for the first 2 months and then monthly thereafter, or as clinically indicated. Myelosuppression was generally reversible and usually managed by withholding Tasigna temporarily or dose reduction [see *Dosage and Administration (2.5)*].

5.2 QT Prolongation

Tasigna has been shown to prolong cardiac ventricular repolarization as measured by the QT interval on the surface ECG in a concentration-dependent manner [see *Adverse Reactions (6.1), Clinical Pharmacology (12.2)*]. Prolongation of the QT interval can result in a type of ventricular tachycardia called torsade de pointes, which may result in syncope, seizure, and/or death. ECGs should be performed at baseline, 7 days after initiation of Tasigna, and periodically as clinically indicated and following dose adjustments [see *Warnings and Precautions (5.12)*].

Tasigna should not be used in patients who have hypokalemia, hypomagnesemia or long QT syndrome. Before initiating Tasigna and periodically, test electrolyte, calcium and magnesium blood levels. Hypokalemia or hypomagnesemia must be corrected prior to initiating Tasigna and these electrolytes should be monitored periodically during therapy [see *Warnings and Precautions (5.12)*].

Significant prolongation of the QT interval may occur when Tasigna is inappropriately taken with food and/or strong CYP3A4 inhibitors and/or medicinal products with a known potential to prolong QT. Therefore, coadministration with food must be avoided and concomitant use with strong CYP3A4 inhibitors and/or medicinal products with a known potential to prolong QT should be avoided [see *Dosage and Administration (2.1), Drug Interactions (7.1, 7.2)*]. The presence of hypokalemia and hypomagnesemia may further prolong the QT interval [see *Warnings and Precautions (5.7, 5.12)*].

5.3 Sudden Deaths

Sudden deaths have been reported in 0.3% of patients with CML treated with Tasigna in clinical studies of 5,661 patients. The relative early occurrence of some of these deaths relative to the initiation of Tasigna suggests the possibility that ventricular repolarization abnormalities may have contributed to their occurrence.

5.4 Cardiac and Arterial Vascular Occlusive Events

Cardiovascular events, including arterial vascular occlusive events, were reported in a randomized, clinical trial in newly diagnosed CML patients and observed in the postmarketing reports of patients receiving Tasigna therapy. With a median time on therapy of 60 months in the clinical trial, cardiovascular events, including arterial vascular occlusive events, occurred in 9.3% and 15.2% of patients in the Tasigna 300 and 400 mg twice daily arms, respectively, and in 3.2% in the imatinib arm. These included cases of cardiovascular events including ischemic heart disease-related cardiac events (5.0% and 9.4% in the Tasigna 300 mg and 400 mg twice daily arms respectively, and 2.5% in the imatinib arm), peripheral arterial occlusive disease (3.6% and

2.9% in the Tasigna 300 mg and 400 mg twice daily arms respectively, and 0% in the imatinib arm), and ischemic cerebrovascular events (1.4% and 3.2% in the Tasigna 300 mg and 400 mg twice daily arms respectively, and 0.7% in the imatinib arm). If acute signs or symptoms of cardiovascular events occur, advise patients to seek immediate medical attention. The cardiovascular status of patients should be evaluated and cardiovascular risk factors should be monitored and actively managed during Tasigna therapy according to standard guidelines [see *Dosage and Administration (2.4)*].

5.5 Pancreatitis and Elevated Serum Lipase

Tasigna can cause increases in serum lipase. Patients with a previous history of pancreatitis may be at greater risk of elevated serum lipase. If lipase elevations are accompanied by abdominal symptoms, interrupt dosing and consider appropriate diagnostics to exclude pancreatitis. Test serum lipase levels monthly or as clinically indicated.

5.6 Hepatotoxicity

Tasigna may result in hepatotoxicity as measured by elevations in bilirubin, AST, ALT, and alkaline phosphatase. Grade 3-4 elevations of bilirubin, AST, and ALT were reported at a higher frequency in pediatric than in adult patients. Monitor hepatic function tests monthly or as clinically indicated [see *Warnings and Precautions (5.12)*].

5.7 Electrolyte Abnormalities

The use of Tasigna can cause hypophosphatemia, hypokalemia, hyperkalemia, hypocalcemia, and hyponatremia. Correct electrolyte abnormalities prior to initiating Tasigna and during therapy. Monitor these electrolytes periodically during therapy [see *Warnings and Precautions (5.12)*].

5.8 Tumor Lysis Syndrome

Tumor lysis syndrome cases have been reported in Tasigna treated patients with resistant or intolerant CML. Malignant disease progression, high WBC counts and/or dehydration were present in the majority of these cases. Due to potential for tumor lysis syndrome, maintain adequate hydration and correct uric acid levels prior to initiating therapy with Tasigna.

5.9 Hemorrhage

Serious hemorrhagic events, including fatal events, have occurred in patients with CML treated with Tasigna. In a randomized trial in patients with newly diagnosed Ph⁺ CML in chronic phase comparing Tasigna and imatinib, Grade 3 or 4 hemorrhage occurred in 1.1% of patients in the Tasigna 300 mg twice daily arm, in 1.8% of patients in the Tasigna 400 mg twice daily arm, and 0.4% of patients in the imatinib arm. GI hemorrhage occurred in 2.9% and 5.1% of patients in the Tasigna 300 mg twice daily and 400 mg twice daily arms and in 1.4% of patients in the imatinib arm, respectively. Grade 3 or 4 events occurred in 0.7% and 1.4% of patients in the Tasigna 300 mg twice daily and 400 mg twice daily arms, respectively, and in no patients in the imatinib arm. Monitor for signs and symptoms of bleeding and medically manage as needed.

5.10 Total Gastrectomy

Since the exposure of Tasigna is reduced in patients with total gastrectomy, perform more frequent monitoring of these patients. Consider dose increase or alternative therapy in patients with total gastrectomy [see *Clinical Pharmacology (12.3)*].

5.11 Lactose

Since the capsules contain lactose, Tasigna is not recommended for patients with rare hereditary problems of galactose intolerance, severe lactase deficiency with a severe degree of intolerance to lactose-containing products, or of glucose-galactose malabsorption.

5.12 Monitoring Laboratory Tests

Complete blood counts should be performed every 2 weeks for the first 2 months and then monthly thereafter. Perform chemistry panels, including electrolytes, calcium, magnesium, liver enzymes, lipid profile, and glucose prior to therapy and periodically. ECGs should be obtained at baseline, 7 days after initiation and periodically thereafter, as well as following dose adjustments [see *Warnings and Precautions (5.2)*]. Monitor lipid profiles

and glucose periodically during the first year of Tasigna therapy and at least yearly during chronic therapy. Should treatment with any HMG-CoA reductase inhibitor (a lipid lowering agent) be needed to treat lipid elevations, evaluate the potential for a drug-drug interaction before initiating therapy as certain HMG-CoA reductase inhibitors are metabolized by the CYP3A4 pathway [see *Drug Interactions (7.1)*]. Assess glucose levels before initiating treatment with Tasigna and monitor during treatment as clinically indicated. If test results warrant therapy, physician should follow their local standards of practice and treatment guidelines.

5.13 Fluid Retention

In the randomized trial in patients with newly diagnosed Ph+ CML in chronic phase, severe (Grade 3 or 4) fluid retention occurred in 3.9% and 2.9% of patients receiving Tasigna 300 mg twice daily and 400 mg twice daily, respectively, and in 2.5% of patients receiving imatinib. Effusions (including pleural effusion, pericardial effusion, ascites) or pulmonary edema, were observed in 2.2% and 1.1% of patients receiving Tasigna 300 mg twice daily and 400 mg twice daily, respectively, and in 2.1% of patients receiving imatinib. Effusions were severe (Grade 3 or 4) in 0.7% and 0.4% of patients receiving Tasigna 300 mg twice daily and 400 mg twice daily, respectively, and in no patients receiving imatinib. Similar events were also observed in postmarketing reports. Monitor patients for signs of severe fluid retention (e.g., unexpected rapid weight gain or swelling) and for symptoms of respiratory or cardiac compromise (e.g., shortness of breath) during Tasigna treatment; evaluate etiology and treat patients accordingly.

5.14 Effects on Growth and Development in Pediatric Patients

Growth retardation has been reported in pediatric patients with Ph+ CML in chronic phase treated with Tasigna. In a pediatric trial with 58 patients with Ph+ CML in chronic phase after a median follow-up of 33 months, 12% (n = 7) of patients experienced a decrease of two main height percentile lines (percentile lines: 5th, 10th, 25th, 50th, 75th, 90th, and 95th). Adverse reactions associated with growth retardation were reported in 3 patients (5%). Monitor growth and development in pediatric patients receiving Tasigna treatment.

5.15 Embryo-Fetal Toxicity

Based on findings from animal studies and its mechanism of action, Tasigna can cause fetal harm when administered to a pregnant woman. In animal reproduction studies, administration of nilotinib to pregnant rats and rabbits during organogenesis caused adverse developmental outcomes including embryo-fetal lethality/fetal effects (small renal papilla, fetal edema, and skeletal variations) in rats and increased resorptions of fetuses and fetal skeletal variations in rabbits at maternal AUCs approximately 2 and 0.5 times, respectively, the AUC in patients receiving the recommended dose. Advise pregnant women of the potential risk to a fetus. Advise females of reproductive potential to use effective contraception during treatment and for at least 14 days after the last dose [see *Use in Specific Populations (8.1, 8.3)* and *Clinical Pharmacology (12.1)*].

5.16 Monitoring of BCR-ABL Transcript Levels

Monitoring of BCR-ABL Transcript Levels in Patients Who Discontinued Tasigna

Monitor BCR-ABL transcript levels in patients eligible for treatment discontinuation using an FDA authorized test validated to measure molecular response levels with a sensitivity of at least MR4.5 (BCR-ABL/ABL \leq 0.0032% IS). In patients who discontinue Tasigna therapy, assess BCR-ABL transcript levels monthly for one year, then every 6 weeks for the second year, and every 12 weeks thereafter during treatment discontinuation [see *Clinical Studies (14.3, 14.4)* and *Dosage and Administration (2.2)*].

Newly diagnosed patients must reinitiate Tasigna therapy within 4 weeks of a loss of Major Molecular Response (MMR, corresponding to MR3.0 or = BCR-ABL/ABL \leq 0.1%IS).

Patients resistant or intolerant to prior treatment which included imatinib must reinitiate Tasigna therapy within 4 weeks of a loss of MMR or confirmed loss of MR4.0 (two consecutive measures separated by at least 4 weeks showing loss of MR4.0, corresponding to = BCR-ABL/ABL \leq 0.01%IS).

For patients who fail to achieve MMR after three months of treatment reinitiation, BCR-ABL kinase domain mutation testing should be performed.

Monitoring of BCR-ABL Transcript Levels in Patients who have Reinitiated Therapy after Loss of Molecular Response

Monitor CBC and BCR-ABL transcripts in patients who reinitiate treatment with Tasigna due to loss of molecular response quantitation every 4 weeks until a major molecular response is re-established, then every 12 weeks.

6 ADVERSE REACTIONS

The following clinically significant adverse reactions can occur with Tasigna and are discussed in greater detail in other sections of labeling:

- Myelosuppression [*see Warnings and Precautions (5.1)*]
- QT Prolongation [*see Boxed Warning, Warnings and Precautions (5.2)*]
- Sudden Deaths [*see Boxed Warning, Warnings and Precautions (5.3)*]
- Cardiac and Arterial Vascular Occlusive Events [*see Warnings and Precautions (5.4)*]
- Pancreatitis and Elevated Serum Lipase [*see Warnings and Precautions (5.5)*]
- Hepatotoxicity [*see Warnings and Precautions (5.6)*]
- Electrolyte Abnormalities [*see Boxed Warning, Warnings and Precautions (5.7)*]
- Hemorrhage [*see Warnings and Precautions (5.9)*]
- Fluid Retention [*see Warnings and Precautions (5.13)*]

6.1 Clinical Trials Experience

Because clinical trials are conducted under widely varying conditions, adverse reaction rates observed in the clinical trials of a drug cannot be directly compared to rates in the clinical trials of another drug and may not reflect the rates observed in practice.

In Adult Patients with Newly Diagnosed Ph+ CML-CP

The data below reflect exposure to Tasigna from a randomized trial in patients with newly diagnosed Ph+ CML in chronic phase treated at the recommended dose of 300 mg twice daily (n = 279). The median time on treatment in the Tasigna 300 mg twice daily group was 61 months (range 0.1 to 71 months). The median actual dose intensity was 593 mg/day in the Tasigna 300 mg twice daily group.

The most common (greater than 10%) non-hematologic adverse drug reactions were rash, pruritus, headache, nausea, fatigue, alopecia, myalgia, and upper abdominal pain. Constipation, diarrhea, dry skin, muscle spasms, arthralgia, abdominal pain, peripheral edema, vomiting, and asthenia were observed less commonly (less than or equal to 10% and greater than 5%) and have been of mild-to-moderate severity, manageable and generally did not require dose reduction.

Increase in QTcF greater than 60 msec from baseline was observed in 1 patient (0.4%) in the 300 mg twice daily treatment group. No patient had an absolute QTcF of greater than 500 msec while on study drug.

The most common hematologic adverse drug reactions (all Grades) were myelosuppression including: thrombocytopenia (18%), neutropenia (15%) and anemia (8%). See Table 9 for Grade 3/4 laboratory abnormalities.

Discontinuation due to adverse reactions, regardless of relationship to study drug, was observed in 10% of patients.

In Adult Patients with Resistant or Intolerant Ph+ CML-CP and CML-AP

In the single-arm, open-label multicenter clinical trial, a total of 458 patients with Ph+ CML-CP and CML-AP resistant to or intolerant to at least one prior therapy including imatinib were treated (CML-CP=321; CML-AP=137) at the recommended dose of 400 mg twice daily.

The median duration of exposure in days for CML-CP and CML-AP patients is 561 (range 1 to 1096) and 264 (range 2 to 1160), respectively. The median dose intensity for patients with CML-CP and CML-AP is 789 mg/day (range 151 to 1110) and 780 mg/day (range 150 to 1149), respectively and corresponded to the planned 400 mg twice daily dosing.

The median cumulative duration in days of dose interruptions for the CML-CP patients was 20 (range 1 to 345), and the median duration in days of dose interruptions for the CML-AP patients was 23 (range 1 to 234).

In patients with CML-CP, the most commonly reported non-hematologic adverse drug reactions (greater than or equal to 10%) were rash, pruritus, nausea, fatigue, headache, constipation, diarrhea, vomiting and myalgia. The common serious drug-related adverse reactions (greater than or equal to 1% and less than 10%) were thrombocytopenia, neutropenia and anemia.

In patients with CML-AP, the most commonly reported non-hematologic adverse drug reactions (greater than or equal to 10%) were rash, pruritus and fatigue. The common serious adverse drug reactions (greater than or equal to 1% and less than 10%) were thrombocytopenia, neutropenia, febrile neutropenia, pneumonia, leukopenia, intracranial hemorrhage, elevated lipase and pyrexia.

Sudden deaths and QT prolongation were reported. The maximum mean QTcF change from baseline at steady-state was 10 msec. Increase in QTcF greater than 60 msec from baseline was observed in 4.1% of the patients and QTcF of greater than 500 msec was observed in 4 patients (less than 1%) [*see Boxed Warning, Warnings and Precautions (5.2, 5.3), Clinical Pharmacology (12.2)*].

Discontinuation due to adverse drug reactions was observed in 16% of CML-CP and 10% of CML-AP patients.

Most Frequently Reported Adverse Reactions

Tables 7 and 8 show the percentage of adult patients experiencing non-hematologic adverse reactions (excluding laboratory abnormalities) regardless of relationship to study drug. Adverse reactions reported in greater than 10% of adult patients who received at least 1 dose of Tasigna are listed.

Table 7: Most Frequently Reported Non-Hematologic Adverse Reactions (Regardless of Relationship to Study Drug) in Adult Patients with Newly Diagnosed Ph+ CML-CP (Greater than or equal to 10% in Tasigna 300 mg Twice Daily or Imatinib 400 mg Once Daily Groups) 60-Month Analysis^a

		Patients with Newly Diagnosed Ph+ CML-CP			
		Tasigna 300 mg twice daily	Imatinib 400 mg once daily	Tasigna 300 mg twice daily	Imatinib 400 mg once daily
		N = 279	N = 280	N = 279	N = 280
Body System and Adverse Reaction		All Grades (%)		CTC Grades ^b 3/4 (%)	
Skin and subcutaneous tissue disorders	Rash	38	19	< 1	2
	Pruritus	21	7	< 1	0
	Alopecia	13	7	0	0
	Dry skin	12	6	0	0
Gastrointestinal disorders	Nausea	22	41	2	2
	Constipation	20	8	< 1	0
	Diarrhea	19	46	1	4
	Vomiting	15	27	< 1	< 1
	Abdominal pain upper	18	14	1	< 1
	Abdominal pain	15	12	2	0
	Dyspepsia	10	12	0	0
Nervous system disorders	Headache	32	23	3	< 1
	Dizziness	12	11	< 1	< 1
General disorders and administration site conditions	Fatigue	23	20	1	1
	Pyrexia	14	13	< 1	0
	Asthenia	14	12	< 1	0
	Peripheral edema	9	20	< 1	0
	Face edema	< 1	14	0	< 1
Musculoskeletal and connective tissue disorders	Myalgia	19	19	< 1	< 1
	Arthralgia	22	17	< 1	< 1
	Muscle spasms	12	34	0	1
	Pain in extremity	15	16	< 1	< 1
	Back pain	19	17	1	1
Respiratory, thoracic and mediastinal disorders	Cough	17	13	0	0
	Oropharyngeal pain	12	6	0	0
	Dyspnea	11	6	2	< 1
Infections and infestations	Nasopharyngitis	27	21	0	0
	Upper respiratory tract infection	17	14	< 1	0
	Influenza	13	9	0	0
	Gastroenteritis	7	10	0	< 1
Eye disorders	Eyelid edema	1	19	0	< 1
	Periorbital edema	< 1	15	0	0
Psychiatric disorders	Insomnia	11	9	0	0

Vascular disorder	Hypertension	10	4	1	<1
-------------------	--------------	----	---	---	----

^aExcluding laboratory abnormalities.

^bNCI Common Terminology Criteria for Adverse Events, Version 3.0.

Table 8: Most Frequently Reported Non-Hematologic Adverse Reactions in Adult Patients with Resistant or Intolerant Ph+ CML Receiving Tasigna 400 mg Twice Daily (Regardless of Relationship to Study Drug) (Greater than or equal to 10% in any Group) 24-Month Analysis^a

Body System and Adverse Reaction		CML-CP		CML-AP	
		N = 321		N = 137	
		All Grades (%)	CTC Grades ^b 3/4 (%)	All Grades (%)	CTC Grades ^b 3/4 (%)
Skin and subcutaneous tissue disorders	Rash	36	2	29	0
	Pruritus	32	<1	20	0
	Night sweat	12	<1	27	0
	Alopecia	11	0	12	0
Gastrointestinal disorders	Nausea	37	1	22	<1
	Constipation	26	<1	19	0
	Diarrhea	28	3	24	2
	Vomiting	29	<1	13	0
	Abdominal pain	15	2	16	3
	Abdominal pain upper	14	<1	12	<1
	Dyspepsia	10	<1	4	0
	Headache	35	2	20	1
General disorders and administration site conditions	Fatigue	32	3	23	<1
	Pyrexia	22	<1	28	2
	Asthenia	16	0	14	1
	Peripheral edema	15	<1	12	0
Musculoskeletal and connective tissue disorders	Myalgia	19	2	16	<1
	Arthralgia	26	2	16	0
	Muscle spasms	13	<1	15	0
	Bone pain	14	<1	15	2
	Pain in extremity	20	2	18	1
	Back pain	17	2	15	<1
	Musculoskeletal pain	11	<1	12	1
Respiratory, thoracic and mediastinal disorders	Cough	27	<1	18	0
	Dyspnea	15	2	9	2
	Oropharyngeal pain	11	0	7	0
Infections and infestations	Nasopharyngitis	24	<1	15	0
	Upper respiratory tract infection	12	0	10	0
Metabolism and nutrition disorders	Decreased appetite ^c	15	<1	17	<1
Psychiatric disorders	Insomnia	12	1	7	0
Vascular disorders	Hypertension	10	2	11	<1

^aExcluding laboratory abnormalities.

^bNCI Common Terminology Criteria for Adverse Events, Version 3.0.

*Also includes preferred term anorexia.

Laboratory Abnormalities

Table 9 shows the percentage of adult patients experiencing treatment-emergent Grade 3/4 laboratory abnormalities in patients who received at least one dose of Tasigna.

Table 9: Percent Incidence of Clinically Relevant Grade 3/4* Laboratory Abnormalities

	Patient Population			
	Newly Diagnosed Adult Ph+ CML-CP		Resistant or Intolerant Adult Ph+	
	Tasigna 300 mg twice daily N = 279 (%)	Imatinib 400 mg once daily N = 280 (%)	CML-CP Tasigna 400 mg twice daily N = 321 (%)	CML-AP Tasigna 400 mg twice daily N = 137 (%)
Hematologic Parameters				
Thrombocytopenia	10	9	30 ¹	42 ³
Neutropenia	12	22	31 ²	42 ⁴
Anemia	4	6	11	27
Biochemistry Parameters				
Elevated lipase	9	4	18	18
Hyperglycemia	7	<1	12	6
Hypophosphatemia	8	10	17	15
Elevated bilirubin (total)	4	<1	7	9
Elevated SGPT (ALT)	4	3	4	4
Hyperkalemia	2	1	6	4
Hyponatremia	1	<1	7	7
Hypokalemia	<1	2	2	9
Elevated SGOT (AST)	1	1	3	2
Decreased albumin	0	<1	4	3
Hypocalcemia	<1	<1	2	5
Elevated alkaline phosphatase	0	<1	<1	1
Elevated creatinine	0	<1	<1	<1

*NCI Common Terminology Criteria for Adverse Events, version 3.0.

¹CML-CP: Thrombocytopenia: 12% were Grade 3, 18% were Grade 4.

²CML-CP: Neutropenia: 16% were Grade 3, 15% were Grade 4.

³CML-AP: Thrombocytopenia: 11% were Grade 3, 32% were Grade 4.

⁴CML-AP: Neutropenia: 16% were Grade 3, 26% were Grade 4.

Elevated total cholesterol (all Grades) occurred in 28% (Tasigna 300 mg twice daily) and 4% (imatinib). Elevated triglycerides (all Grades) occurred in 12% and 8% of patients in the Tasigna and imatinib arms, respectively. Hyperglycemia (all Grades) occurred in 50% and 31% of patients in the Tasigna and imatinib arms, respectively.

Most common biochemistry laboratory abnormalities (all Grades) were alanine aminotransferase increased (72%), blood bilirubin increased (59%), aspartate aminotransferase increased (47%), lipase increased (28%), blood glucose increased (50%), blood cholesterol increased (28%), and blood triglyceride increased (12%).

Treatment discontinuation in Ph+ CML-CP patients who have achieved a sustained molecular response (MR4.5)

In eligible patients who discontinued Tasigna therapy after attaining a sustained molecular response (MR4.5), musculoskeletal symptoms (e.g., myalgia, pain in extremity, arthralgia, bone pain, spinal pain, or musculoskeletal pain), were reported more frequently than before treatment discontinuation in the first year, as noted in Table 10. The rate of new musculoskeletal symptoms generally decreased in the second year after treatment discontinuation.

In the newly diagnosed population in whom musculoskeletal symptoms occurred at any time during the TFR phase, 23/53 (43.4%) had not resolved by the TFR end date or data cut-off date. In the population previously treated with imatinib in whom musculoskeletal events occurred at any time during the TFR phase, 32/57 (56.1%) had not resolved by the data cut-off date.

The rate of musculoskeletal symptoms decreased in patients who entered the Tasigna treatment reinitiation (NTRI) phase, at 11/88 (12.5%) in the newly diagnosed population and 14/56 (25%) in the population previously treated with imatinib. Other adverse reactions observed in the Tasigna re-treatment phase were similar to those observed during Tasigna use in patients with newly diagnosed Ph+ CML-CP and resistant or intolerant Ph+ CML-CP and CML-AP.

Table 10: Musculoskeletal Symptoms Occurring Upon Treatment Discontinuation in the Context of Treatment-free Remission (TFR)

Ph+ CML-CP patients	Entire TFR period in all TFR patients				By time interval, in subset of patients in TFR greater than 48 weeks						
	N	Median follow-up in TFR	Patients with musculoskeletal symptoms		N	Year prior to Tasigna discontinuation		1 st year after Tasigna discontinuation		2 nd year after Tasigna discontinuation	
			All Grades	Grade 3/4		All Grades	Grade 3/4	All Grades	Grade 3/4	All Grades	Grade 3/4
Newly Diagnosed	190	76 weeks	28%	1%	100	17%	0%	34%	2%	9%	0%
Previously treated with imatinib	126	99 weeks	45%	2%	73	14%	0%	48%	3%	15%	1%

Abbreviation: TFR, treatment-free remission.

Additional Data from Clinical Trials

The following adverse drug reactions were reported in adult patients in the Tasigna clinical studies at the recommended doses. These adverse drug reactions are ranked under a heading of frequency, the most frequent first using the following convention: common (greater than or equal to 1% and less than 10%), uncommon (greater than or equal to 0.1% and less than 1%), and unknown frequency (single events). For laboratory abnormalities, very common events (greater than or equal to 10%), which were not included in Tables 7 and 8, are also reported. These adverse reactions are included based on clinical relevance and ranked in order of decreasing seriousness within each category, obtained from 2 clinical studies:

1. Adult patients with newly diagnosed Ph+ CML-CP 60 month analysis and,
2. Adult patients with resistant or intolerant Ph+ CML-CP and CMP-AP 24 months' analysis.

Infections and Infestations: Common: folliculitis. Uncommon: pneumonia, bronchitis, urinary tract infection, candidiasis (including oral candidiasis). Unknown frequency: hepatitis B reactivation, sepsis, subcutaneous abscess, anal abscess, furuncle, tinea pedis.

Neoplasms Benign, Malignant, and Unspecified: Common: skin papilloma. Unknown frequency: oral papilloma, paraproteinemia.

Blood and Lymphatic System Disorders: Common: leukopenia, eosinophilia, febrile neutropenia, pancytopenia, lymphopenia. Unknown frequency: thrombocythemia, leukocytosis.

Immune System Disorders: Unknown frequency: hypersensitivity.

Endocrine Disorders: Uncommon: hyperthyroidism, hypothyroidism. Unknown frequency: hyperparathyroidism secondary, thyroiditis.

Metabolism and Nutrition Disorders: Very Common: hypophosphatemia. Common: electrolyte imbalance (including hypomagnesemia, hyperkalemia, hypokalemia, hyponatremia, hypocalcemia, hypercalcemia, hyperphosphatemia), diabetes mellitus, hyperglycemia, hypercholesterolemia, hyperlipidemia,

hypertriglyceridemia. Uncommon: gout, dehydration, increased appetite. Unknown frequency: hyperuricemia, hypoglycemia.

Psychiatric Disorders: Common: depression, anxiety. Unknown frequency: disorientation, confusional state, amnesia, dysphoria.

Nervous System Disorders: Common: peripheral neuropathy, hypoesthesia, paresthesia. Uncommon: intracranial hemorrhage, ischemic stroke, transient ischemic attack, cerebral infarction, migraine, loss of consciousness (including syncope), tremor, disturbance in attention, hyperesthesia. Unknown frequency: basilar artery stenosis, brain edema, optic neuritis, lethargy, dysesthesia, restless legs syndrome.

Eye Disorders: Common: eye hemorrhage, eye pruritus, conjunctivitis, dry eye (including xerophthalmia). Uncommon: vision impairment, vision blurred, visual acuity reduced, photopsia, hyperemia (scleral, conjunctival, ocular), eye irritation, conjunctival hemorrhage. Unknown frequency: papilledema, diplopia, photophobia, eye swelling, blepharitis, eye pain, chorioretinopathy, conjunctivitis allergic, ocular surface disease.

Ear and Labyrinth Disorders: Common: vertigo. Unknown frequency: hearing impaired, ear pain, tinnitus.

Cardiac Disorders: Common: angina pectoris, arrhythmia (including atrioventricular block, cardiac flutter, extrasystoles, atrial fibrillation, tachycardia, bradycardia), palpitations, electrocardiogram QT prolonged. Uncommon: cardiac failure, myocardial infarction, coronary artery disease, cardiac murmur, coronary artery stenosis, myocardial ischemia, pericardial effusion, cyanosis. Unknown frequency: ventricular dysfunction, pericarditis, ejection fraction decrease.

Vascular Disorders: Common: flushing. Uncommon: hypertensive crisis, peripheral arterial occlusive disease, intermittent claudication, arterial stenosis limb, hematoma, arteriosclerosis. Unknown frequency: shock hemorrhagic, hypotension, thrombosis, peripheral artery stenosis.

Respiratory, Thoracic and Mediastinal Disorders: Common: dyspnea exertional, epistaxis, dysphonia. Uncommon: pulmonary edema, pleural effusion, interstitial lung disease, pleuritic pain, pleurisy, pharyngolaryngeal pain, throat irritation. Unknown frequency: pulmonary hypertension, wheezing.

Gastrointestinal Disorders: Common: pancreatitis, abdominal discomfort, abdominal distension, dysgeusia, flatulence. Uncommon: gastrointestinal hemorrhage, melena, mouth ulceration, gastroesophageal reflux, stomatitis, esophageal pain, dry mouth, gastritis, sensitivity of teeth. Unknown frequency: gastrointestinal ulcer perforation, retroperitoneal hemorrhage, hematemesis, gastric ulcer, esophagitis ulcerative, subileus, enterocolitis, hemorrhoids, hiatus hernia, rectal hemorrhage, gingivitis.

Hepatobiliary Disorders: Very common: hyperbilirubinemia. Common: hepatic function abnormal. Uncommon: hepatotoxicity, toxic hepatitis, jaundice. Unknown frequency: cholestasis, hepatomegaly.

Skin and Subcutaneous Tissue Disorders: Common: eczema, urticaria, erythema, hyperhidrosis, contusion, acne, dermatitis (including allergic, exfoliative and acneiform). Uncommon: exfoliative rash, drug eruption, pain of skin, ecchymosis. Unknown frequency: psoriasis, erythema multiforme, erythema nodosum, skin ulcer, palmar-plantar erythrodysesthesia syndrome, petechiae, photosensitivity, blister, dermal cyst, sebaceous hyperplasia, skin atrophy, skin discoloration, skin exfoliation, skin hyperpigmentation, skin hypertrophy, hyperkeratosis.

Musculoskeletal and Connective Tissue Disorders: Common: bone pain, musculoskeletal chest pain, musculoskeletal pain, back pain, neck pain, flank pain, muscular weakness. Uncommon: musculoskeletal stiffness, joint swelling. Unknown frequency: arthritis.

Renal and Urinary Disorders: Common: pollakiuria. Uncommon: dysuria, micturition urgency, nocturia. Unknown frequency: renal failure, hematuria, urinary incontinence, chromaturia.

Reproductive System and Breast Disorders: Uncommon: breast pain, gynecomastia, erectile dysfunction. Unknown frequency: breast induration, menorrhagia, nipple swelling.

General Disorders and Administration Site Conditions: Common: pyrexia, chest pain (including non-cardiac chest pain), pain, chest discomfort, malaise. Uncommon: gravitational edema, influenza-like illness, chills, feeling body temperature change (including feeling hot, feeling cold). Unknown frequency: localized edema.

Investigations: Very Common: alanine aminotransferase increased, aspartate aminotransferase increased, lipase increased, lipoprotein cholesterol (including very low density and high density) increased, total cholesterol increased, blood triglycerides increased. Common: hemoglobin decreased, blood amylase increased, gamma-glutamyltransferase increased, blood creatinine phosphokinase increased, blood alkaline phosphatase increased, weight decreased, weight increased, globulins decreased. Uncommon: blood lactate dehydrogenase increased, blood urea increased. Unknown frequency: troponin increased, blood bilirubin unconjugated increased, insulin C-peptide decreased, blood parathyroid hormone increased.

In Pediatric Patients with Newly Diagnosed Ph+ CML-CP or Resistant or Intolerant Ph+ CML-CP

The data below reflect exposure to Tasigna from two studies in pediatric patients from 2 to less than 18 years of age with either newly diagnosed Ph+ CML-CP or imatinib/dasatinib resistant or intolerant Ph+ CML-CP treated at the recommended dose of 230 mg/m² twice daily (n = 69) [see *Clinical Studies (14.5)*]. The median time on treatment with Tasigna was 13.8 months (range: 0.7 to 30.9 months). The median actual dose intensity was 435.5 mg/m²/day (range: 149 to 517 mg/m²/day), and the median relative dose intensity was 94.7% (range: 32 to 112%). Forty patients (58.0%) had relative dose intensity superior to 90%.

In pediatric patients with Ph+ CML-CP, the most common (greater than 20%) non-hematologic adverse drug reactions were headache, rash, hyperbilirubinemia, alanine aminotransferase increased, pyrexia, nausea, upper respiratory tract infection, aspartate aminotransferase increased, and vomiting. The most common (greater than 5%) Grade 3/4 non-hematologic adverse drug reactions were alanine aminotransferase increased and hyperbilirubinemia.

Laboratory abnormalities of hyperbilirubinemia (Grade 3/4: 13%) and transaminase elevation (AST Grade 3/4: 1%, ALT Grade 3/4: 9%), were reported at a higher frequency than in adult patients.

The most common hematological adverse drug reactions (greater than or equal to 30% of patients, of all Grades) were decreases in total white blood cells (54%), platelet count (44%), absolute neutrophils (41%), absolute lymphocytes (32%), and hemoglobin (30%).

Discontinuation due to adverse reactions occurred in 9 patients (13%). The adverse reactions leading to discontinuation were hyperbilirubinemia (6%) and rash (4%).

Increase in QTcF greater than 30 msec from baseline was observed in 17 patients (25%). No patient had an absolute QTcF of greater than 500 msec or QTcF increase of greater than 60 msec from baseline.

Growth Retardation in Pediatric Population

In a multicenter, open-label, single-arm study of 58 pediatric patients with newly diagnosed or resistant Ph+ CML-CP treated with Tasigna, with a median exposure of 33 months in each cohort, adverse reactions associated with growth and deceleration of growth in regard to height were reported in 3 patients (5%). The adverse reactions include growth retardation in 2 adolescent patients and growth hormone deficiency with body height below normal in the remaining patient (age category: child). Of the 58 pediatric patients, 12% (n = 7) experienced a decrease of two main height percentiles compared with baseline (percentile lines: 5th, 10th, 25th, 50th, 75th, 90th, and 95th). Close monitoring of growth in pediatric patients under Tasigna treatment is recommended [see *Warnings and Precautions (5.14)*].

6.2 Postmarketing Experience

The following adverse reactions have been identified during post approval use of Tasigna. Because these reactions are reported voluntarily from a population of uncertain size, it is not always possible to reliably estimate their frequency or establish a causal relationship to drug exposure.

Blood and Lymphatic System Disorders: thrombotic microangiopathy

7 DRUG INTERACTIONS

7.1 Effect of Other Drugs on Tassigna

Strong CYP3A Inhibitors

Concomitant use with a strong CYP3A inhibitor increased nilotinib concentrations compared to Tassigna alone [see *Clinical Pharmacology (12.3)*], which may increase the risk of Tassigna toxicities. Avoid concomitant use of strong CYP3A inhibitors with Tassigna. If patients must be coadministered a strong CYP3A4 inhibitor, reduce Tassigna dose [see *Dosage and Administration (2.8)*].

Strong CYP3A Inducers

Concomitant use with a strong CYP3A inducer decreased nilotinib concentrations compared to Tassigna alone [see *Clinical Pharmacology (12.3)*], which may reduce Tassigna efficacy. Avoid concomitant use of strong CYP3A inducers with Tassigna.

Proton Pump Inhibitors (PPIs)

Concomitant use with a PPI decreased nilotinib concentrations compared to Tassigna alone [see *Clinical Pharmacology (12.3)*], which may reduce Tassigna efficacy. Avoid concomitant use of PPI with Tassigna. As an alternative to PPIs, use H2 blockers approximately 10 hours before or approximately 2 hours after the dose of Tassigna, or use antacids approximately 2 hours before or approximately 2 hours after the dose of Tassigna.

7.2 Drugs that Prolong the QT Interval

Avoid coadministration of Tassigna with agents that may prolong the QT interval such as anti-arrhythmic drugs [see *Boxed Warning, Dosage and Administration (2.4), Warnings and Precautions (5.2), Drug Interactions (7.1), Clinical Pharmacology (12.2)*].

8 USE IN SPECIFIC POPULATIONS

8.1 Pregnancy

Risk Summary

Based on findings from animal studies and the mechanism of action, Tassigna can cause fetal harm when administered to a pregnant woman [see *Clinical Pharmacology (12.1)*].

There are no available data in pregnant women to inform the drug-associated risk. In animal reproduction studies, administration of nilotinib to pregnant rats and rabbits during organogenesis caused adverse developmental outcomes including embryo-fetal lethality, fetal effects, and fetal variations in rats and rabbits at maternal exposures (AUC) approximately 2 and 0.5 times, respectively, the exposures in patients at the recommended dose (see *Data*). Advise pregnant women of the potential risk to a fetus.

The background risk of major birth defects and miscarriage for the indicated population is unknown. All pregnancies have a background risk of birth defect, loss, or other adverse outcomes. In the U.S. general population, the estimated background risk of major birth defects and miscarriage in clinically recognized pregnancies are 2-4% and 15-20%, respectively.

Data

Animal Data

In embryo-fetal development studies in rats and rabbits, pregnant animals received oral doses of nilotinib up to 100 mg/kg/day and 300 mg/kg/day, respectively, during the period of organogenesis.

In rats, oral administration of nilotinib produced embryo-lethality/fetal effects at doses ≥ 30 mg/kg/day. At ≥ 30 mg/kg/day skeletal variations of incomplete ossification of the frontals and misshapen sternebra were noted, and there was an increased incidence of small renal papilla and fetal edema. At 100 mg/kg/day, nilotinib was associated with maternal toxicity (decreased gestation weight, gravid uterine weight, net weight gain, and food consumption) and resulted in a single incidence of cleft palate and two incidences of pale skin were noted in the

fetuses. A single incidence of dilated ureters was noted in a fetus also displaying small renal papilla at 100 mg/kg/day. Additional variations of forepaw and hindpaw phalanx unossified, fused sternebra, bipartite sternebra ossification, and incomplete ossification of the cervical vertebra were noted at 100 mg/kg/day.

In rabbits, oral administration of nilotinib resulted in the early sacrifice of two females, maternal toxicity and increased resorption of fetuses at 300 mg/kg/day. Fetal skeletal variations (incomplete ossification of the hyoid, bent hyoid, supernumerary short detached ribs and the presence of additional ossification sites near the nasals, frontals and in the sternebra column) were also increased at this dose in the presence of maternal toxicity. Slight maternal toxicity was evident at 100 mg/kg/day but there were no reproductive or embryo-fetal effects at this dose.

At 30 mg/kg/day in rats and 300 mg/kg/day in rabbits, the maternal systemic exposure (AUC) were 72700 ng*hr/mL and 17100 ng*hr/mL respectively, representing approximately 2 and 0.5 times the exposure in humans at the highest recommended dose 400 mg twice daily.

When pregnant rats were dosed with nilotinib during organogenesis and through lactation, the adverse effects included a longer gestational period, lower pup body weights until weaning and decreased fertility indices in the pups when they reached maturity, all at a maternal dose of 60 mg/kg (i.e., 360 mg/m², approximately 0.7 times the clinical dose of 400 mg twice daily based on body surface area). At doses up to 20 mg/kg (i.e., 120 mg/m², approximately 0.25 times the clinical dose of 400 mg twice daily based on body surface area) no adverse effects were seen in the maternal animals or the pups.

8.2 Lactation

Risk Summary

No data are available regarding the presence of nilotinib or its metabolites in human milk or its effects on a breastfed child or on milk production. However, nilotinib is present in the milk of lactating rats. Because of the potential for serious adverse reactions in a breastfed child, advise lactating women not to breastfeed during treatment with Tasigna and for at least 14 days after the last dose.

Animal Data

After a single 20 mg/kg of [¹⁴C] nilotinib dose to lactating rats, the transfer of parent drug and its metabolites into milk was observed. The overall milk-to-plasma exposure ratio of total radioactivity was approximately 2, based on the AUC_{0-24h} or AUC_{0-∞} values. No rat metabolites of nilotinib were detected that were unique to milk.

8.3 Females and Males of Reproductive Potential

Pregnancy Testing

Based on animal studies, Tasigna can cause fetal harm when administered to a pregnant woman [*see Use in Specific Populations (8.1)*]. Females of reproductive potential should have a pregnancy test prior to starting treatment with Tasigna.

Contraception

Females

Based on animal studies, Tasigna can cause fetal harm when administered to a pregnant woman [*see Use in Specific Populations (8.1)*]. Advise females of reproductive potential to use effective contraception during treatment with Tasigna and for at least 14 days after the last dose.

Infertility

The risk of infertility in females or males of reproductive potential has not been studied in humans. In studies in rats and rabbits, the fertility in males and females was not affected [*see Nonclinical Toxicology (13.1)*].

8.4 Pediatric Use

The safety and effectiveness of Tasigna have been established in pediatric patients greater than or equal to 1 year of age with newly diagnosed and resistant or intolerant Ph+ CML in chronic phase [see *Clinical Studies (14.5)*]. There are no data for pediatric patients under 2 years of age. Use of Tasigna in pediatric patients 1 to less than 2 years of age is supported by efficacy in pediatric patients 2 to 6 years of age.

Use of Tasigna in pediatric patients 1 to less than 18 years of age is supported by evidence from two clinical trials [see *Clinical Studies (14.5)*]. The 25 patients with newly diagnosed Ph+ CML-CP were in the following age groups: 6 children (age 2 to less than 12 years) and 19 adolescents (age 12 to less than 18 years). The 44 patients with resistant or intolerant Ph+ CML-CP included 18 children (age 2 to less than 12 years) and 26 adolescents (age 12 to less than 18 years). All pediatric patients received Tasigna treatment at a dose of 230 mg/m² twice daily, rounded to the nearest 50 mg dose (to a maximum single dose of 400 mg). No differences in efficacy or safety were observed between the different age subgroups in the two trials.

The frequency, type, and severity of adverse reactions observed were generally consistent with those observed in adults, with the exception of the laboratory abnormalities of hyperbilirubinemia (Grade 3/4: 13%) and transaminase elevation (AST Grade 3/4: 1%, ALT Grade 3/4: 9%), which were reported at a higher frequency in pediatric patients than in adults [see *Adverse Reactions (6.1)*]. For pediatric growth and development, growth retardation has been reported in pediatric patients with Ph+ CML-CP treated with Tasigna [see *Warnings and Precautions (5.14) and Adverse Reactions (6.1)*].

The long-term effects of prolonged treatment with Tasigna in pediatric patients are unknown.

8.5 Geriatric Use

In the clinical trials of Tasigna (patients with newly diagnosed Ph+ CML-CP and resistant or intolerant Ph+ CML-CP and CML-AP), approximately 12% and 30% of patients were 65 years or over respectively.

- Patients with newly diagnosed Ph+ CML-CP: There was no difference in major molecular response between patients aged less than 65 years and those greater than or equal to 65 years.
- Patients with resistant or intolerant CML-CP: There was no difference in major cytogenetic response rate between patients aged less than 65 years and those greater than or equal to 65 years.
- Patients with resistant or intolerant CML-AP: The hematologic response rate was 44% in patients less than 65 years of age and 29% in patients greater than or equal to 65 years.

No major differences for safety were observed in patients greater than or equal to 65 years of age as compared to patients less than 65 years.

8.6 Cardiac Disorders

In the clinical trials, patients with a history of uncontrolled or significant cardiovascular disease, including recent myocardial infarction, congestive heart failure, unstable angina or clinically significant bradycardia, were excluded. Caution should be exercised in patients with relevant cardiac disorders [see *Boxed Warning, Warnings and Precautions (5.2)*].

8.7 Hepatic Impairment

Reduce the Tasigna dosage in patients with hepatic impairment and monitor the QT interval closely in these patients [see *Dosage and Administration (2.7), and Clinical Pharmacology (12.3)*].

10 OVERDOSAGE

Overdose with nilotinib has been reported, where an unspecified number of Tasigna capsules were ingested in combination with alcohol and other drugs. Events included neutropenia, vomiting, and drowsiness. In the event of overdose, observe the patient and provide appropriate supportive treatment.

11 DESCRIPTION

Tasigna contains nilotinib, which belongs to a pharmacologic class of drugs known as kinase inhibitors.

Nilotinib drug substance, in the form of monohydrochloride monohydrate, is a white to slightly yellowish to slightly greenish yellow powder with the molecular formula and weight, respectively, of $C_{28}H_{22}F_3N_7O \cdot HCl \cdot H_2O$ and 584 (corresponding molecular formula and weight of nilotinib base, anhydrous are $C_{28}H_{22}F_3N_7O$ and 529 respectively). The solubility of nilotinib in aqueous solutions decreases with increasing pH. Nilotinib is not optically active. The pK_{a1} was determined to be 2.1; pK_{a2} was estimated to be 5.4.

The chemical name of nilotinib monohydrochloride monohydrate is 4-methyl-N-[3-(4-methyl-1H-imidazol-1-yl)-5-(trifluoromethyl)phenyl]-3-[[4-(3-pyridinyl)-2-pyrimidinyl]amino]-benzamide, monohydrochloride, monohydrate. Its structure is shown below:

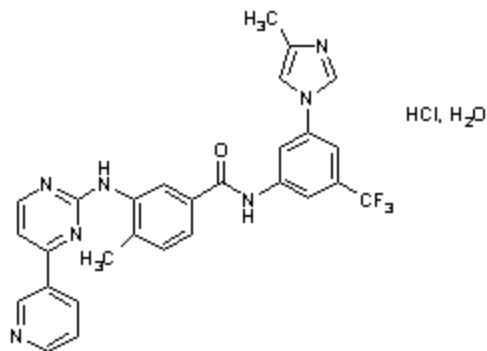

Tasigna (nilotinib) capsules, for oral use, contain 50 mg, 150 mg, or 200 mg nilotinib base, anhydrous (equivalent to 55 mg, 166 mg, and 221 mg nilotinib monohydrochloride monohydrate respectively) with the following inactive ingredients: colloidal silicon dioxide, crospovidone, lactose monohydrate, magnesium stearate and poloxamer 188. The capsules contain gelatin, iron oxide (red), iron oxide (yellow), iron oxide (black), and titanium dioxide.

12 CLINICAL PHARMACOLOGY

12.1 Mechanism of Action

Nilotinib is an inhibitor of the BCR-ABL kinase. Nilotinib binds to and stabilizes the inactive conformation of the kinase domain of ABL protein. In vitro, nilotinib inhibited BCR-ABL mediated proliferation of murine leukemic cell lines and human cell lines derived from patients with Ph⁺ CML. Under the conditions of the assays, nilotinib was able to overcome imatinib resistance resulting from BCR-ABL kinase mutations, in 32 out of 33 mutations tested. Nilotinib inhibited the autophosphorylation of the following kinases at IC₅₀ values as indicated: BCR-ABL (20 to 60 nM), PDGFR (69 nM), c-KIT (210 nM), CSF-1R (125 to 250 nM), and DDR1 (3.7 nM).

12.2 Pharmacodynamics

Based on exposure-response analyses for efficacy, a relationship between drug exposure and a greater likelihood of response was observed in clinical studies. Based on exposure-response analyses for safety, a relationship between exposure and a greater likelihood of safety events, including a higher occurrence of total bilirubin elevations, was observed in clinical studies.

Cardiac Electrophysiology

Tasigna is associated with concentration-dependent QT prolongation. At a dose of Tasigna 400 mg twice daily given without food in healthy subjects, the maximum mean placebo-adjusted QTcF changes were 10.4 msec (90% CI: 2.85, 18.0). After a single dose of Tasigna 800 mg (two times the maximum approved recommended dosage) given with a high fat meal to healthy subjects, the maximum mean placebo-adjusted QTcF changes were 18.0 msec (90% CI: 9.65, 25.8). Peak plasma concentrations in the QT study were 26% lower than or

comparable with those observed in patients enrolled in the single-arm study [see *Boxed Warning, Warnings and Precautions (5.2), and Adverse Reactions (6.1)*].

12.3 Pharmacokinetics

Steady-state nilotinib exposure was dose-dependent with less than dose-proportional increases in systemic exposure at dose levels higher than 400 mg given as once or twice daily dosing. In adult patients with resistant or intolerant Ph+ CML given Tasigna 400 mg twice daily, the steady-state mean (%CV) C_{max} and AUC_{0-12h} were 2260 ng/ml (35%) and 18000 ng·h/ml (33%), respectively. In adult patients with newly diagnosed Ph+ CML given Tasigna 300 mg twice daily, the steady-state mean (%CV) C_{max} and AUC_{0-12h} were 1540 ng/ml (48%) and 13337 ng·h/ml (46%), respectively.

Steady state conditions were achieved by Day 8. An increase in serum exposure to nilotinib between the first dose and steady state was approximately 2-fold for daily dosing and 3.8-fold for twice daily dosing. The average steady state nilotinib trough and peak concentrations did not change over 12 months.

Absorption

Relative bioavailability of nilotinib capsule is approximately 50%, as compared to an oral drink solution (pH of 1.2 to 1.3). Peak concentrations of nilotinib are reached 3 hours after oral administration. Nilotinib is a substrate of P-gp *in vitro*.

Median steady-state trough concentration of nilotinib was decreased by 53% in patients with total gastrectomy compared to patients who had not undergone surgeries [see *Warnings and Precautions (5.10)*].

Effect of Food

Compared to the fasted state, the systemic exposure (AUC) increased by 82% when the dose was given 30 minutes after a high fat meal (meal of 800 to 1000 calories with fat being 50% of total caloric content; approximately: 150 calories from protein, 250 calories from carbohydrates, and 500-600 calories from fat).

Single dose administration of two 200 mg nilotinib capsules each dispersed in 1 teaspoon of applesauce and administered within 15 minutes was shown to be bioequivalent to a single dose administration of two 200 mg intact capsules.

Distribution

The blood-to-serum ratio of nilotinib is 0.68. Serum protein binding is approximately 98%.

Elimination

The mean (CV%) apparent elimination half-life is estimated to be approximately 17 hours (69%) and the mean (CV%) apparent clearance approximates 29 L/h (61%).

Metabolism

Nilotinib is primarily metabolized via CYP3A4-mediated oxidation and to a minor extent by CYP2C8. Nilotinib is the main circulating component in the serum. None of the metabolites contribute significantly to the pharmacological activity of nilotinib.

Excretion

After a single dose of radiolabeled nilotinib, more than 90% of the administered dose was eliminated within 7 days: 93% of the dose in feces. Parent drug accounted for 69% of the dose.

Specific Populations

Age, sex, race/ethnicity, or body weight did not significantly affect the pharmacokinetics of nilotinib. The effect of renal impairment on nilotinib pharmacokinetics is unknown.

Pediatric Patients

Following administration of the approved recommend pediatric dosage of nilotinib, steady-state exposure of nilotinib were within 2-fold to adult patients treated with 400 mg twice daily. Steady-state C_{\min} was comparable across all age groups (pediatric patients from ages 2 to less than 18 years), diseases (patients with newly diagnosed and resistant or intolerant Ph⁺ CML) and studies.

Body surface area correlated with nilotinib clearance and was the primary factor responsible for the PK differences between pediatrics and adults.

Patients with Hepatic Impairment

Following a single dose of Tasigna 200 mg (0.5 times the maximum approved recommended dosage), the mean AUC of nilotinib increased 1.4-fold, 1.4-fold, and 1.6-fold in subjects with mild (Child-Pugh class A), moderate (Child-Pugh class B) and severe (Child-Pugh class C) hepatic impairment, respectively, compared to subjects with normal hepatic function.

Drug Interaction Studies

Clinical Studies

Strong CYP3A Inhibitors: Coadministration of ketoconazole (a strong CYP3A inhibitor) 400 mg once daily for 6 days increased nilotinib AUC by approximately 3-fold. A single concurrent intake of double-strength grapefruit juice increased the nilotinib AUC by 1.3-fold.

Strong CYP3A Inducers: Coadministration of rifampicin (a strong CYP3A inducer) 600 mg daily for 12 days decreased nilotinib AUC by approximately 80%.

Proton Pump Inhibitors (PPIs): Tasigna displays pH-dependent aqueous solubility. Coadministration of multiple doses of esomeprazole (a PPI) at 40 mg daily decreased the nilotinib AUC by 34%. No significant change in nilotinib pharmacokinetics was observed when a single 400 mg dose of Tasigna was administered 10 hours after and 2 hours before famotidine (an H₂ blocker), or administered 2 hours after and 2 hours before an antacid (e.g., aluminum hydroxide, magnesium hydroxide, simethicone).

Moderate CYP3A inhibitors: Following coadministration of nilotinib 400 mg twice daily with imatinib (a moderate CYP3A inhibitor) 400 mg daily or 400 mg twice daily, the AUC increased 30% to 50% for nilotinib and approximately 20% for imatinib.

CYP3A4 Substrates: Multiple doses of Tasigna increased the systemic exposure of oral midazolam (a substrate of CYP3A4) 2.6-fold.

CYP2C9 Substrates: Single-dose of Tasigna did not change the pharmacokinetics and pharmacodynamics of warfarin (a CYP2C9 substrate).

In Vitro Studies Where Drug Interaction Potential Was Not Further Evaluated Clinically

CYP Substrates: Nilotinib is a competitive inhibitor of CYP2C8, CYP2D6, and is an inducer of CYP2B6 and CYP2C8.

Substrates of Transporters: Nilotinib is an inhibitor of UGT1A1 and P-gp.

12.5 Pharmacogenomics

Tasigna can increase bilirubin levels. The (TA)⁷/(TA)⁷ genotype of UGT1A1 was associated with a statistically significant increase in the risk of hyperbilirubinemia relative to the (TA)⁶/(TA)⁶ and (TA)⁶/(TA)⁷ genotypes. However, the largest increases in bilirubin were observed in the (TA)⁷/(TA)⁷ genotype (UGT1A1*28) patients [see Warnings and Precautions (5.6)].

13 NONCLINICAL TOXICOLOGY

13.1 Carcinogenesis, Mutagenesis, Impairment of Fertility

A 2-year carcinogenicity study was conducted orally in rats at nilotinib doses of 5, 15, and 40 mg/kg/day. Exposures in animals at the highest dose tested were approximately 2- to 3-fold the human exposure (based on

AUC) at the nilotinib dose of 400 mg twice daily. The study was negative for carcinogenic findings. A 26-week carcinogenicity study was conducted orally in Tg.rasH2 mice, a model genetically modified to enhance susceptibility to neoplastic transformation, at nilotinib doses of 30, 100, and 300 mg/kg/day. Nilotinib induced in the skin and subcutis statistically significant increases in the incidence of papillomas in females and of papillomas and combined papillomas and carcinomas in males at 300 mg/kg/day. The no-observed-adverse-effect-level (NOAEL) for skin neoplastic lesions was 100 mg/kg/day.

Nilotinib was not mutagenic in a bacterial mutagenesis (Ames) assay, was not clastogenic in a chromosome aberration assay in human lymphocytes, did not induce DNA damage (comet assay) in L5178Y mouse lymphoma cells, nor was it clastogenic in an in vivo rat bone marrow micronucleus assay with two oral treatments at doses up to 2000 mg/kg/dose.

There were no effects on male or female rat and female rabbit mating or fertility at doses up to 180 mg/kg in rats (approximately 4- to 7-fold for males and females, respectively, the AUC in patients at the dose of 400 mg twice daily) or 300 mg/kg in rabbits (approximately one-half the AUC in patients at the dose of 400 mg twice daily). The effect of Tasigna on human fertility is unknown. In a study where male and female rats were treated with nilotinib at oral doses of 20 to 180 mg/kg/day (approximately 1- to 6.6-fold the AUC in patients at the dose of 400 mg twice daily) during the pre-mating and mating periods and then mated, and dosing of pregnant rats continued through gestation Day 6, nilotinib increased post-implantation loss and early resorption, and decreased the number of viable fetuses and litter size at all doses tested.

14 CLINICAL STUDIES

14.1 Adult Newly Diagnosed Ph+ CML-CP

The ENESTnd (Evaluating Nilotinib Efficacy and Safety in clinical Trials-Newly Diagnosed patients) study (NCT00471497) was an open-label, multicenter, randomized trial conducted to determine the efficacy of Tasigna versus imatinib tablets in adult patients with cytogenetically confirmed newly diagnosed Ph+ CML-CP. Patients were within 6 months of diagnosis and were previously untreated for CML-CP, except for hydroxyurea and/or anagrelide. Efficacy was based on a total of 846 patients: 283 patients in the imatinib 400 mg once daily group, 282 patients in the Tasigna 300 mg twice daily group, 281 patients in the Tasigna 400 mg twice daily group.

Median age was 46 years in the imatinib group and 47 years in both Tasigna groups, with 12%, 13%, and 10% of patients greater than or equal to 65 years of age in imatinib 400 mg once daily, Tasigna 300 mg twice daily and Tasigna 400 mg twice daily treatment groups, respectively. There were slightly more male than female patients in all groups (56%, 56%, and 62% in imatinib 400 mg once daily, Tasigna 300 mg twice daily and Tasigna 400 mg twice daily treatment groups, respectively). More than 60% of all patients were Caucasian, and 25% were Asian.

The primary data analysis was performed when all 846 patients completed 12 months of treatment (or discontinued earlier). Subsequent analyses were done when patients completed 24, 36, 48, and 60 months of treatment (or discontinued earlier). The median time on treatment was approximately 61 months in all three treatment groups.

The primary efficacy endpoint was major molecular response (MMR) at 12 months after the start of study medication. MMR was defined as less than or equal to 0.1% BCR-ABL/ABL % by international scale measured by RQ-PCR, which corresponds to a greater than or equal to 3 log reduction of BCR-ABL transcript from standardized baseline. Efficacy endpoints are summarized in Table 12.

Two patients in the Tasigna arm progressed to either accelerated phase or blast crisis (both within the first 6 months of treatment) while 12 patients on the imatinib arm progressed to either accelerated phase or blast crisis (7 patients within first 6 months, 2 patients within 6 to 12 months, 2 patients within 12 to 18 months and 1 patient within 18 to 24 months).

Table 12: Efficacy (MMR and CCyR) of Tasigna Compared to Imatinib in Adult Newly Diagnosed Ph+ CML-CP (ENESTnd)

	Tasigna 300 mg Twice Daily	Imatinib 400 mg Once Daily
	N = 282	N = 283
MMR at 12 months (95% CI)	44% (38.4, 50.3)	22% (17.6, 27.6)
P-Value ^a	< 0.0001	
CCyR ^b by 12 months (95% CI)	80% (75.0, 84.6)	65% (59.2, 70.6)
MMR at 24 months (95% CI)	62% (55.8, 67.4)	38% (31.8, 43.4)
CCyR ^b by 24 months (95% CI)	87% (82.4, 90.6)	77% (71.7, 81.8)

Abbreviation: CI, confidence interval.

^aCMH test stratified by Sokal risk group.

^bCCyR: 0% Ph⁺ metaphases. Cytogenetic responses were based on the percentage of Ph⁺ metaphases among greater than or equal to 20 metaphase cells in each bone marrow sample.

By the 60 months, MMR was achieved by 77% of patients on Tasigna and 60% of patients on imatinib; MR4.5 was achieved by 53.5% of patients on Tasigna and 31.4% on imatinib. Median overall survival was not reached in either arm. At the time of the 60-month final analysis, the estimated survival rate was 93.7% for patients on Tasigna and 91.7% for patients on imatinib.

14.2 Adult Patients with Resistant or Intolerant Ph⁺ CML-CP and CML-AP

Study CAMN107A2101 (referred to as Study A2101) (NCT00109707) was a single-arm, open-label, multicenter study conducted to evaluate the efficacy and safety of Tasigna (400 mg twice daily) in patients with imatinib-resistant or -intolerant CML with separate cohorts for chronic and accelerated phase disease. The definition of imatinib resistance included failure to achieve a complete hematologic response (by 3 months), cytogenetic response (by 6 months) or major cytogenetic response (by 12 months) or progression of disease after a previous cytogenetic or hematologic response. Imatinib intolerance was defined as discontinuation of treatment due to toxicity and lack of a major cytogenetic response at time of study entry. At the time of data cut-off, 321 patients with CML-CP and 137 patients with CML-AP with a minimum follow-up of 24 months were enrolled. In this study, about 50% of CML-CP and CML-AP patients were males, over 90% (CML-CP) and 80% (CML-AP) were Caucasian, and approximately 30% were age 65 years or older.

Overall, 73% of patients were imatinib resistant while 27% were imatinib intolerant. The median time of prior imatinib treatment was approximately 32 (CML-CP) and 28 (CML-AP) months. Prior therapy included hydroxyurea in 85% of patients, interferon in 56% and stem cell or bone marrow transplant in 8%. The median highest prior imatinib dose was 600 mg per day for patients with CML-CP and CML-AP, and the highest prior imatinib dose was greater than or equal to 600 mg/day in 74% of all patients with 40% of patients receiving imatinib doses greater than or equal to 800 mg/day.

Median duration of Tasigna treatment was 18.4 months in patients with CML-CP and 8.7 months in patients with CML-AP.

The efficacy endpoint in CML-CP was unconfirmed major cytogenetic response (MCyR) which included complete and partial cytogenetic responses.

The efficacy endpoint in CML-AP was confirmed hematologic response (HR), defined as either a complete hematologic response (CHR) or no evidence of leukemia (NEL). The rates of response for CML-CP and CML-AP patients are reported in Table 13.

Median durations of response had not been reached at the time of data analysis.

Table 13: Efficacy of Tasigna in Adult Resistant or Intolerant Ph⁺ CML-CP and CML-AP (Study A2101)

Cytogenetic Response Rate (Unconfirmed) (%)^a	
--	--

	Chronic Phase (n = 321)
Major (95% CI)	51% (46%–57%)
Complete (95% CI)	37% (32%–42%)
Partial (95% CI)	15% (11%–19%)
	Accelerated Phase (n = 137)
Hematologic Response Rate (Confirmed) (95% CI)^b	39% (31%–48%)
Complete Hematologic Response Rate (95% CI)	30% (22%–38%)
No Evidence of Leukemia (95% CI)	9% (5%–16%)

^aCytogenetic response criteria: Complete (0% Ph + metaphases) or partial (1% to 35%). Cytogenetic responses were based on the percentage of Ph-positive metaphases among greater than or equal to 20 metaphase cells in each bone marrow sample.

^bHematologic response = CHR + NEL (all responses confirmed after 4 weeks).

CHR (CML-CP): WBC less than $10 \times 10^9/L$, platelets less than $450,000/mm^3$, no blasts or promyelocytes in peripheral blood, less than 5% myelocytes + metamyelocytes in bone marrow, less than 20% basophils in peripheral blood, and no extramedullary involvement.

CHR (CML-AP): neutrophils greater than or equal to $1.5 \times 10^9/L$, platelets greater than or equal to $100 \times 10^9/L$, no myeloblasts in peripheral blood, myeloblasts less than 5% in bone marrow, and no extramedullary involvement.

NEL: same criteria as for CHR but neutrophils greater than or equal to $1.0 \times 10^9/L$ and platelets greater than or equal to $20 \times 10^9/L$ without transfusions or bleeding.

Adult Patients with Chronic Phase

The MCyR rate in 321 CML-CP patients was 51%. The median time to MCyR among responders was 2.8 months (range 1 to 28 months). The median duration of MCyR cannot be estimated. The median duration of exposure on this single arm-trial was 18.4 months. Among the CML-CP patients who achieved MCyR, 62% of them had MCyR lasting more than 18 months. The CCyR rate was 37%.

Adult Patients with Accelerated Phase

The overall confirmed hematologic response rate in 137 patients with CML-AP was 39%. The median time to first hematologic response among responders was 1 month (range 1 to 14 months). Among the CML-AP patients who achieved HR, 44% of them had a response lasting for more than 18 months.

After imatinib failure, 24 different BCR-ABL mutations were noted in 42% of chronic phase and 54% of accelerated phase CML patients who were evaluated for mutations.

14.3 Treatment discontinuation in newly diagnosed Ph+ CML-CP patients who have achieved a sustained molecular response (MR4.5)

The ENESTfreedom (Evaluating Nilotinib Efficacy and Safety in clinical Trials-freedom) study (NCT01784068) is an open-label, multicenter, single-arm study, where 215 adult patients with Ph+ CML-CP treated with Tasigna in first-line for ≥ 2 years who achieved MR4.5 as measured with the MolecularMD MRDx[®] BCR-ABL Test were enrolled to continue Tasigna treatment for an additional 52 weeks (Tasigna consolidation phase).

Of the 215 patients, 190 patients (88.4%) entered the “Treatment-free Remission” (TFR) phase after achieving a sustained molecular response (MR4.5) during the consolidation phase, defined by the following criteria:

- The 4 last quarterly assessments (taken every 12 weeks) were at least MR4 (BCR-ABL/ABL $\leq 0.01\%$ IS), and maintained for 1 year
- The last assessment being MR4.5 (BCR-ABL/ABL $\leq 0.0032\%$ IS)
- No more than two assessments falling between MR4 and MR4.5 ($0.0032\% \text{ IS} < \text{BCR-ABL/ABL} \leq 0.01\% \text{ IS}$).

The median age of patients who entered the TFR phase was 55 years, 49.5% were females, and 21.1% of the patients were ≥ 65 years of age. BCR-ABL levels were monitored every 4 weeks during the first 48 weeks of

the TFR phase. Monitoring frequency was intensified to every 2 weeks upon the loss of MR4.0. Biweekly monitoring ended at one of the following time points:

- Loss of MMR requiring patient to reinitiate Tasigna treatment
- When the BCR-ABL levels returned to a range between MR4.0 and MR4.5
- When the BCR-ABL levels remained lower than MMR for 4 consecutive measurements (8 weeks from initial loss of MR4.0).

Any patient with loss of MMR during the TFR phase reinitiated Tasigna treatment at 300 mg twice daily or at a reduced dose level of 400 mg once daily if required from the perspective of tolerance, within 5 weeks after the collection date of the blood sample demonstrating loss of MMR. Patients who required reinitiation of Tasigna treatment were monitored for BCR-ABL levels every 4 weeks for the first 24 weeks and then every 12 weeks thereafter in patients who regained MMR.

Efficacy was based on the 96-week analysis data cut-off date, by which time, 91 patients (47.9%) discontinued from the TFR phase due to loss of MMR, and 1 (0.5%), 1 (0.5%), 1 (0.5%) and 3 patients (1.6%) due to death from unknown cause, physician decision, lost to follow-up and subject decision, respectively. Among the 91 patients who discontinued the TFR phase due to loss of MMR, 88 patients restarted Tasigna treatment and 3 patients permanently discontinued from the study.

By the 96-week data cut-off, of the 88 patients who restarted treatment due to loss of MMR in the TFR phase, 87 patients (98.9%) patients regained MMR (one patient discontinued study permanently due to subject decision after 7.1 weeks of retreatment without regaining MMR) and 81 patients (92.0%) regained MR4.5 by the time of the cut-off date. The cumulative rate of MMR and MR4.5 regained at 24 weeks since treatment reinitiation was 97.7% (86/88 patients) and 86.4% (76/88 patients), respectively.

Table 14: Efficacy Results for ENESTfreedom

Patients Who Entered the Treatment Free Remission (TFR) Phase (Full Analysis Set, N = 190)			
	Patients in TFR phase ¹ at the specified time point		Loss of MMR ² by the specified time point
	%	95% CI	%
24 weeks	62.1	(54.8, 69.0)	35.8
48 weeks	51.6	(44.2, 58.9)	45.8
96 weeks	48.9	(41.6, 56.3)	47.9

Abbreviation: CI, confidence interval.

¹Patients in MMR at the specified time point in the TFR phase.

²Based on the time to event (loss of MMR) data during the TFR phase.

Among the 190 patients in the TFR phase, 98 patients had a treatment-free survival (TFS) event (defined as discontinuation from TFR phase due to any reason, loss of MMR, death due to any cause, progression to AP/BC up to the end of TFR phase, or reinitiation of treatment due to any cause in the study) by the 96-week cut-off date.

Figure 14-1 Kaplan-Meier estimate of treatment-free survival after start of TFR (Full Analysis Set ENESTfreedom)

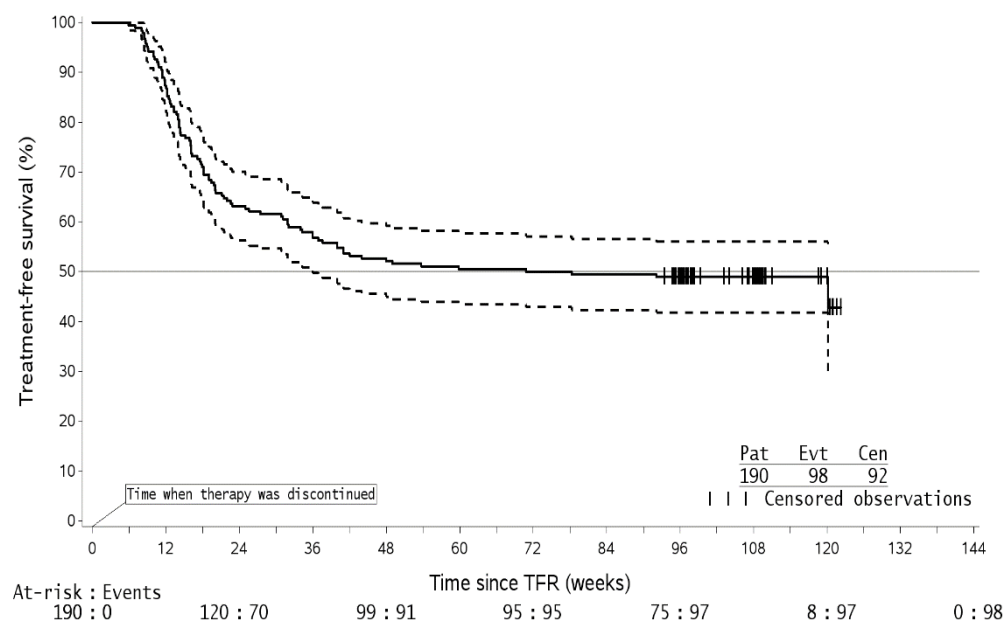

1. For a given time point, the points on the dashed curves represent the 95% confidence limits for the associated KM estimate on the solid curve.
2. By the time of the 96-week data cut-off date, one single patient lost MMR at week 120, at the time when only 8 patients were considered at risk. This explains the artificial drop at the end of the curve.

14.4 Treatment discontinuation in Ph+ CML-CP patients who have achieved a sustained molecular response (MR4.5) on Tasigna following prior imatinib therapy

The ENESTop (Evaluating Nilotinib Efficacy and Safety in clinical Trials-STop) study (NCT01698905) is an open-label, multicenter, single-arm study, where 163 adult patients with Ph+ CML-CP taking tyrosine kinase inhibitors (TKIs) for ≥ 3 years (imatinib as initial TKI therapy for more than 4 weeks without documented MR4.5 on imatinib at the time of switch to Tasigna, then switched to Tasigna for at least 2 years), and who achieved MR4.5 on Tasigna treatment as measured with the MolecularMD MRDx[®] BCR-ABL Test were enrolled to continue Tasigna treatment for an additional 52 weeks (Tasigna consolidation phase). Of the 163 patients, 126 patients (77.3%) entered the TFR phase after achieving a sustained molecular response (MR4.5) during the consolidation phase, defined by the following criterion:

- The 4 last quarterly assessments (taken every 12 weeks) showed no confirmed loss of MR4.5 (BCR-ABL/ABL $\leq 0.0032\%$ IS) during 1 year.

The median age of patients who entered the TFR phase was 56 years, 55.6% were females, and 27.8% of the patients were ≥ 65 years of age. The median actual dose intensity during the 52-week Tasigna consolidation phase was 771.8 mg/day with 52.4%, 29.4%, 0.8%, 16.7% and 0.8% of patients receiving a daily Tasigna dose of 800 mg, 600 mg, 450mg, 400mg and 300mg just before entry into the TFR phase, respectively.

Patients who entered the TFR phase but experienced two consecutive measurements of BCR-ABL/ABL $> 0.01\%$ IS were considered having a confirmed loss of MR4.0, triggering reinitiation of Tasigna treatment. Patients with loss of MMR in the TFR phase immediately restarted Tasigna treatment without confirmation. All patients who restarted Tasigna therapy had BCR-ABL transcript levels monitored every 4 weeks for the first 24 weeks, then once every 12 weeks.

Efficacy was based on the 96-week analysis data cut-off date, by which time, 61 patients (48.4%) had discontinued from the TFR phase: 58 patients (46.0%) due to loss of MMR or confirmed loss of MR4.0, 2 patients (1.6%) due to subject/guardian decision and one patient (0.8%) due to pregnancy. Among the 58

patients who discontinued from the TFR phase due to confirmed loss of MR4.0 or loss of MMR, 56 patients restarted Tasigna therapy and 2 patients permanently discontinued from the study.

By the 96-week data cut-off, of the 56 patients who restarted Tasigna treatment due to confirmed loss of MR4.0 or loss of MMR in the TFR phase, 52 patients (92.9%) regained MR4.0 and MR4.5; 4 patients (7.1%) did not regain MR4.0 by the time of the cut-off date. The cumulative rate of MR4 and MR4.5 regained by 48-weeks since treatment reinitiation, was 92.9% (52/56 patients) and 91.1% (51/56 patients), respectively.

Table 15: Efficacy Results for ENESTop

Patients Who Entered the Treatment Free Remission (TFR) Phase (Full Analysis Set, N = 126)			
	Patients in TFR phase ¹ at the specified time point		Loss of MMR or confirmed loss of MR4 ² by the specified time point
	%	95% CI	%
24 weeks	60.3	(51.2, 68.9)	38.9
48 weeks	57.9	(48.8, 66.7)	41.3
96 weeks	53.2	(44.1, 62.1)	43.7

¹Patients without loss of MMR or confirmed loss of MR4 by specified time point of TFR phase.

²Based on the time to event (loss of MMR or confirmed loss of MR4) data during the TFR phase.

Among the 126 patients in the TFR phase, 61 patients (48.4%) had a treatment-free survival (TFS) event (defined as discontinuation from TFR phase due to any reason, loss of MMR, confirmed loss of MR4, death due to any cause, progression to AP/BC up to the end of TFR phase, or reinitiation of treatment due to any cause in the study) on or before the 96-month cut-off date.

Figure 14-2 Kaplan-Meier estimate of treatment-free survival after start of TFR (Full Analysis Set ENESTop)

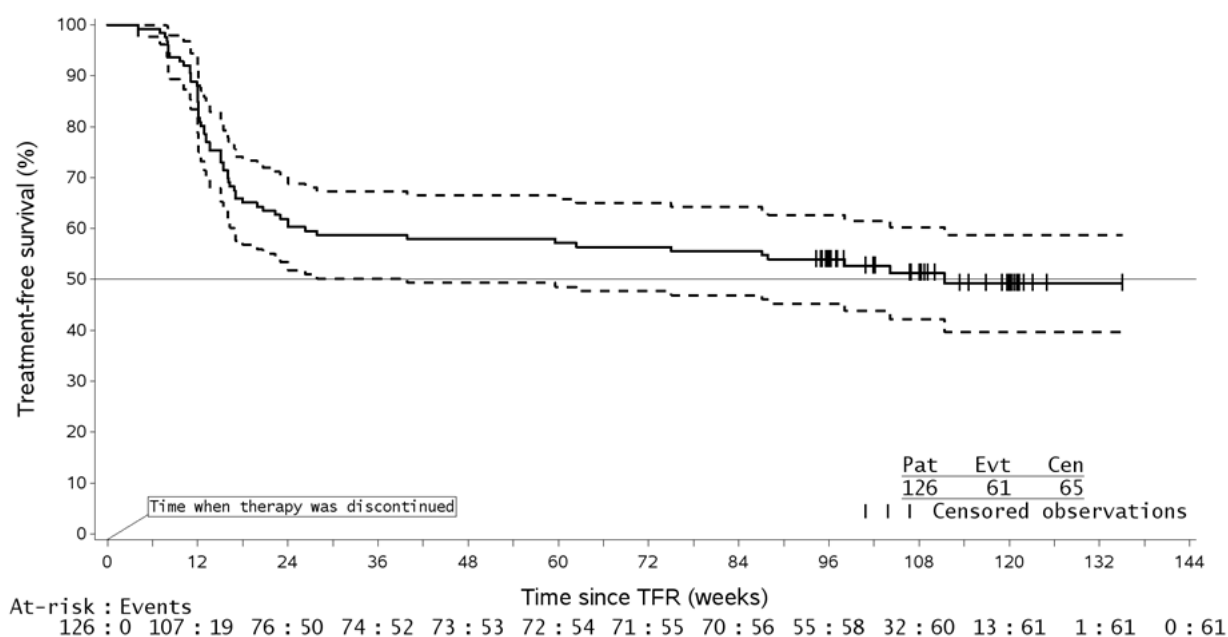

- For a given time point, the points on the dashed curves represent the 95% confidence limits for the associated KM estimate on the solid curve.

14.5 Pediatric Patients with Newly Diagnosed Ph+ CML-CP or Resistant or Intolerant Ph+ CML-CP

The safety and efficacy of Tasigna in pediatric patients with Ph+ CML-CP have been investigated in two studies: Study CAMN107A2120 (NCT01077544), an open-label, single-arm, multi-center study that evaluated the pharmacokinetics, safety, and preliminary efficacy of Tasigna in pediatric patients with Ph+ CML resistant or intolerant to imatinib or dasatinib (n = 11), and Study CAMN107A2203 (NCT01844765), an open-label, single-arm, multi-center study evaluating the efficacy and safety of Tasigna in pediatric patients with Ph+ CML-CP resistant or intolerant to imatinib or dasatinib (n = 33) and newly diagnosed Ph+ CML-CP (n = 25). In both studies, patients received Tasigna treatment at a dose of 230 mg/m² twice daily, rounded to the nearest 50 mg dose (to a maximum single dose of 400 mg). Data was pooled from a total of 69 pediatric patients (from 2 to less than 18 years of age) with either newly diagnosed Ph+ CML-CP (n = 25; 6 children from 2 to less than 12 years and 19 adolescents from 12 to less than 18 years) or imatinib/dasatinib resistant or intolerant Ph+ CML-CP (n = 44; 18 children from 2 to less than 12 years and 26 adolescents from 12 to less than 18 years).

The median time on treatment with Tasigna was 13.80 months (range: 0.7 to 30.9 months).

In patients with resistant or intolerant CML, the major molecular response (MMR; BCR-ABL/ABL ≤ 0.1% IS) rate was 40.9% (18/44, 95% CI: 26.3%, 56.8%) at 12 cycles (28 days per cycle). In patients with newly diagnosed CML, the MMR rate was 60.0% (15/25, 95% CI: 38.7%, 78.9%) at 12 cycles. In patients with resistant or intolerant CML, the cumulative MMR rate was 47.7% (21/44) by cycle 12. In patients with newly diagnosed CML, the cumulative MMR rate was 64.0% (16/25) by cycle 12.

Among the 21 patients with resistant or intolerant CML who were in MMR at any time on treatment, the median time to first MMR was 2.8 months (range: 0.0 to 11.3). For the 17 patients with newly diagnosed CML who achieved MMR, the median time to first MMR was 5.6 months (range: 2.7 to 16.6).

Among patients with resistant or intolerant CML, 4.5% of patients achieved BCR-ABL/ABL ≤ 0.0032% IS (MR4.5) by the cut-off date. Among patients with newly diagnosed CML, the percentage of patients who achieved MR4.5 was 28.0%.

None of the 21 patients with resistant or intolerant CML who were in MMR on treatment had confirmed loss of MMR, with a median follow-up of 11.3 months. Among the 17 patients with newly diagnosed CML who achieved MMR, one patient had confirmed loss of MMR 3 months after achieving this response; in these patients, the median follow-up was 11.1 months. One patient with resistant or intolerant CML progressed to AP/BC after about 10 months on treatment.

16 HOW SUPPLIED/STORAGE AND HANDLING

Tasigna (nilotinib) 50 mg capsules are red opaque cap and light yellow opaque body hard gelatin capsules, size 4 with black radial imprint "NVR/ABL." Tasigna (nilotinib) 150 mg capsules are red opaque hard gelatin capsules, size 1 with black axial imprint "NVR/BCR." Tasigna (nilotinib) 200 mg capsules are light yellow opaque hard gelatin capsules, size 0 with the red axial imprint "NVR/TKI." Tasigna 50 mg capsules are supplied in bottles and Tasigna 150 mg and 200 mg capsules are supplied in blister packs.

50 mg

Bottle of 120 capsules.....NDC 0078-0951-66

150 mg

Carton of 4 blister packs of (4x28)NDC 0078-0592-87

Blisters of 28 capsulesNDC 0078-0592-51

200 mg

Carton of 4 blister packs of (4x28)NDC 0078-0526-87

Blisters of 28 capsulesNDC 0078-0526-51

Tasigna (nilotinib) capsules should be stored at 25°C (77°F); excursions permitted between 15°C to 30°C (59°F to 86°F) [see USP Controlled Room Temperature].

17 PATIENT COUNSELING INFORMATION

Advise the patient to read the FDA-approved patient labeling (Medication Guide).

A Medication Guide is required for distribution with Tasigna. The complete text of the Medication Guide is reprinted at the end of this document.

Myelosuppression

Advise patients that treatment with Tasigna can cause serious thrombocytopenia, neutropenia, and anemia. Advise patients to seek immediate medical attention if symptoms suggestive of low blood counts occur, such as fever, chills or other signs of infection, unexplained bleeding or bruising, or unexplained weakness or shortness of breath [*see Warnings and Precautions (5.1)*].

QT Prolongation

Advise patients that Tasigna can cause possibly life-threatening, abnormal heart beat. Advise patients to seek immediate medical attention if symptoms of abnormal heart beat occur, such as feeling light-headed, faint or experiencing an irregular heartbeat [*see Warnings and Precautions (5.2)*].

Cardiac and Arterial Vascular Occlusive Events

Advise patients that cardiovascular events (including ischemic heart disease, peripheral arterial occlusive disease, and ischemic cerebrovascular events) have been reported. Advise patients to seek immediate medical attention if any symptoms suggestive of a cardiovascular event occur, such as chest or leg pain, numbness or weakness, or problems walking or speaking occur suddenly [*see Warnings and Precautions (5.4)*].

Pancreatitis and Elevated Serum Lipase

Advise patients that Tasigna can increase the risk of pancreatitis and that patients with a previous history of pancreatitis may be at greater risk. Advise patients to seek immediate medical attention if symptoms suggestive of pancreatitis occur, such as sudden stomach area pain with accompanying nausea and vomiting [*see Warnings and Precautions (5.5)*].

Hepatotoxicity

Advise patients that Tasigna can increase the risk of hepatotoxicity and that patients with previous history of liver diseases may be at risk. Advise patients to seek immediate medical attention if any symptoms suggestive of hepatotoxicity occur, such as stomach pain, yellow skin and eyes, and dark-colored urine [*see Warnings and Precautions (5.6)*].

Taking Tasigna

Advise patients to take Tasigna doses twice daily approximately 12 hours apart. The capsules should be swallowed whole with water.

Advise patients to take Tasigna on an empty stomach. No food should be consumed for at least 2 hours before the dose is taken and for at least 1 hour after the dose is taken. Patients should not consume grapefruit products and other foods that are known to inhibit CYP3A4 at any time during Tasigna treatment [*see Dosage and Administration (2.1), Drug Interactions (7.1, 7.2) and Medication Guide*].

If the patient missed a dose of Tasigna, the patient should take the next scheduled dose at its regular time. The patient should not take two doses at the same time.

Should patients be unable to swallow capsules, the contents of each capsule may be dispersed in one teaspoon of applesauce and the mixture swallowed immediately (within 15 minutes).

Tumor Lysis Syndrome

Advise patients that Tasigna can cause tumor lysis syndrome and to seek immediate medical attention if any symptoms suggestive of tumor lysis syndrome occur such as an abnormal heartbeat or less urine production [*see Warnings and Precautions (5.8)*].

Hemorrhage

Advise patients that serious hemorrhagic events, including fatal events, have occurred in patients with CML treated with Tasigna. Advise patients to seek immediate medical attention if symptoms suggestive of hemorrhage occur, such as uncontrolled bleeding, changes in eyesight, unconsciousness, or sudden headache or sudden confusion in surroundings [see *Warnings and Precautions (5.9)*].

Fluid Retention

Advise patients that Tasigna can cause fluid retention and to seek immediate medical attention if any symptoms suggestive of fluid retention such as shortness of breath, rapid weight gain, or swelling occur [see *Warnings and Precautions (5.13)*].

Effects on Growth and Development in Pediatric Patients

Inform pediatric patients and their caregivers of the possibility of developing growth abnormalities. Growth retardation has been reported in pediatric patients treated with Tasigna. Therefore, monitor growth and development in pediatric patients [see *Warnings and Precautions (5.14)*].

Treatment Free Remission (TFR)

Advise patients that frequent monitoring is required to detect possible loss of remission if TFR is attempted. Advise patients that musculoskeletal symptoms such as muscle pain, pain in extremity, joint pain, bone pain, or spinal pain, may occur more frequently than before treatment discontinuation [see *Warnings and Precautions (5.16) and Medication Guide*].

Drug Interactions

Advise patients that Tasigna and certain other medicines, including over the counter medications or herbal supplements (such as St. John's Wort), can interact with each other [see *Drug Interactions (7)*].

Embryo-Fetal Toxicity

Advise females to inform their healthcare provider if they are pregnant or become pregnant. Inform female patients of the risk to a fetus and potential loss of the pregnancy [see *Use in Specific Populations (8.1)*].

Advise females of reproductive potential to use effective contraception during treatment and for at least 14 days after receiving the last dose of Tasigna [see *Warnings and Precautions (5.15) and Use in Specific Populations (8.1, 8.3)*].

Lactation

Advise lactating women not to breastfeed during treatment with Tasigna and for at least 14 days after the last dose [see *Use in Specific Populations (8.2)*].

Compliance

Advise patients of the following:

- Continue taking Tasigna every day for as long as their doctor tells them.
- This is a long-term treatment.
- Do not change dose or stop taking Tasigna without first consulting their doctor.
- If a dose is missed, take the next dose as scheduled. Do not take a double dose to make up for the missed capsules.

Medication Guide
TASIGNA® (ta-sig-na)
(nilotinib)
capsules

What is the most important information I should know about Tasigna?

Tasigna can cause a possible life-threatening heart problem called QTc prolongation. QTc prolongation causes an irregular heartbeat, which may lead to sudden death.

Your healthcare provider should check the electrical activity of your heart with a test called an electrocardiogram (ECG):

- before starting Tasigna
- 7 days after starting Tasigna
- with any dose changes
- regularly during Tasigna treatment

You may lower your chances for having QTc prolongation with Tasigna if you:

- **Take Tasigna on an empty stomach:**
 - Avoid eating food for at least 2 hours before the dose is taken, and
 - Avoid eating food for at least 1 hour after the dose is taken.
- Avoid grapefruit, grapefruit juice, and any supplement containing grapefruit extract during treatment with Tasigna. Food and grapefruit products increase the amount of Tasigna in your body.
- Avoid taking other medicines or supplements with Tasigna that can also cause QTc prolongation.
- Tasigna can interact with many medicines and supplements and increase your chance for serious and life-threatening side effects.
- Do not take any other medicine during treatment with Tasigna unless your healthcare provider tells you it is okay to do so.
- If you cannot swallow Tasigna capsules whole, you may open the Tasigna capsule and sprinkle the contents of each capsule in 1 teaspoon of applesauce (puréed apple). Swallow the mixture right away (within 15 minutes). For more information, see “How should I take Tasigna?”

Call your healthcare provider right away if you feel lightheaded, faint, or have an irregular heartbeat during treatment with Tasigna. These can be symptoms of QTc prolongation.

What is Tasigna?

Tasigna is a prescription medicine used to treat:

- adults and children who have been newly diagnosed with a certain type of leukemia called Philadelphia chromosome positive chronic myeloid leukemia (Ph+ CML) in chronic phase.
- adults with chronic phase Ph+ CML or accelerated phase Ph+ CML who:
 - are no longer benefiting from other treatments, including imatinib (Gleevec), **or**
 - have taken other treatments, including imatinib (Gleevec), and cannot tolerate them.
- children with chronic phase Ph+ CML who:
 - are no longer benefiting from treatment with a tyrosine-kinase inhibitor medicine, **or**
 - have taken a tyrosine-kinase inhibitor medicine and cannot tolerate it.

It is not known if Tasigna is safe and effective in children younger than 1 year of age with newly diagnosed, resistant, or intolerant Ph+ CML in chronic phase.

The long-term effects of treating children with Tasigna for a long period of time are not known.

Who should not take Tasigna?

Do not take if you have:

- low levels of potassium or magnesium in your blood
- long QTc syndrome

Before taking Tasigna, tell your healthcare provider about all of your medical conditions, including if you:

- have heart problems
- have had a stroke or other problems due to decreased blood flow to the brain
- have problems with decreased blood flow to your legs
- have irregular heartbeat
- have QTc prolongation or a family history of it
- have liver problems
- have had pancreatitis
- have low blood levels of potassium or magnesium in your blood
- have a severe problem with lactose (milk sugar) or other sugars. Tasigna capsules contain lactose. Most people who have mild or moderate lactose intolerance can take Tasigna.

- have bleeding problems
- had a surgical procedure involving the removal of the entire stomach (total gastrectomy)
- are pregnant or plan to become pregnant. Tasigna can harm your unborn baby. Tell your healthcare provider right away if you are pregnant, or if you become pregnant during treatment with Tasigna.

In females who are able to become pregnant:

- Your healthcare provider should do a pregnancy test before you start treatment with Tasigna.
- Use effective birth control (contraception) during treatment with Tasigna and for at least 14 days after the last dose.
- are breastfeeding or plan to breastfeed. It is not known if Tasigna passes into your breast milk. Do not breastfeed during treatment and for at least 14 days after your last dose of Tasigna.

Tell your healthcare provider about all the medicines you take, including prescription and over-the-counter medicines, vitamins and herbal supplements.

If you need to take antacids (medicines to treat heartburn) do not take them at the same time that you take Tasigna. If you take:

- **a medicine to block the amount of acid produced in the stomach (H2 blocker):** Take these medicines **about 10 hours before** you take Tasigna, **or about 2 hours after** you take Tasigna.
- **an antacid that contains aluminum hydroxide, magnesium hydroxide, and simethicone to reduce the amount of acid in the stomach:** Take these medicines **about 2 hours before or about 2 hours after** you take Tasigna.

Tasigna can interact with many medicines and supplements and increase your chance for serious and life-threatening side effects. **See “What is the most important information I should know about Tasigna?”**

How should I take Tasigna?

- Take Tasigna exactly as your healthcare provider tells you to take it.
- Do not change your dose or stop taking Tasigna unless your healthcare provider tells you.
- Tasigna is a long-term treatment.
- Your healthcare provider will tell you how many Tasigna capsules to take and when to take them.
- If your child takes Tasigna, your healthcare provider will change the dose as your child grows.
- **Tasigna must be taken on an empty stomach.**
 - **Avoid eating food for at least 2 hours before the dose is taken, and**
 - **Avoid eating food for at least 1 hour after the dose is taken.**
- Swallow Tasigna capsules whole with water. If you cannot swallow Tasigna capsules whole, tell your healthcare provider.
- **If you cannot swallow Tasigna capsules whole:**
 - **Open the Tasigna capsules and sprinkle the contents in 1 teaspoon of applesauce (puréed apple).**
 - **Do not use more than 1 teaspoon of applesauce.**
 - **Only use applesauce. Do not sprinkle Tasigna onto other foods.**
 - **Swallow the mixture right away (within 15 minutes).**
- Do not drink grapefruit juice, eat grapefruit, or take supplements containing grapefruit extract at any time during treatment. **See “What is the most important information I should know about Tasigna?”**
- If you miss a dose, just take your next dose at your regular time. Do not take 2 doses at the same time to make up for a missed dose.
- If you take too much Tasigna, call your healthcare provider or go to the nearest hospital emergency room right away. Symptoms may include vomiting and drowsiness.
- During treatment with Tasigna your healthcare provider will do tests to check for side effects and to see how well Tasigna is working for you. The tests will check your:
 - heart
 - blood cells (white blood cells, red blood cells, and platelets). Your blood cells should be checked every 2 weeks for the first 2 months and then monthly.
 - electrolytes (potassium, magnesium)
 - pancreas and liver function
 - bone marrow samples

Your healthcare provider may change your dose. Your healthcare provider may have you stop Tasigna for some time or lower your dose if you have side effects with it.

- Your healthcare provider will monitor your CML during treatment with Tasigna to see if you are in a remission. After at least 3 years of treatment with Tasigna, your healthcare provider may do certain tests to determine if you

continue to be in remission. Based on your test results, your healthcare provider may decide if you may be eligible to try stopping treatment with Tasigna. This is called Treatment Free Remission (TFR).

- Your healthcare provider will carefully monitor your CML during and after you stop taking Tasigna. Based on your test results, your healthcare provider may need to re-start your Tasigna if your CML is no longer in remission.
- It is important that you are followed by your healthcare provider and undergo frequent monitoring to find out if you need to re-start your Tasigna treatment because you are no longer in TFR. Follow your healthcare provider's instructions about re-starting Tasigna if you are no longer in TFR.

What are the possible side effects of Tasigna?

Tasigna may cause serious side effects, including:

- **See “What is the most important information I should know about Tasigna?”**
- **Low blood cell counts.** Low blood cell counts (red blood cells, white blood cells, and platelets) are common with Tasigna, but can also be severe. Your healthcare provider will check your blood counts regularly during treatment with Tasigna. Call your healthcare provider or get medical help right away if you develop any signs or symptoms of low blood counts including:
 - fever
 - chills or other signs of infection
 - unexplained bleeding or bruising
 - unexplained weakness
 - shortness of breath
- **Decreased blood flow to the leg, heart, or brain.** People who have recently been diagnosed with Ph+ CML and take Tasigna may develop decreased blood flow to the leg, the heart, or brain. Get medical help right away if you suddenly develop any of the following symptoms:
 - chest pain or discomfort
 - numbness or weakness
 - problems walking or speaking
 - leg pain
 - your leg feels cold
 - change in the skin color of your leg
- **Pancreas inflammation (pancreatitis).** Tell your healthcare provider right away if you develop any symptoms of pancreatitis including sudden stomach area pain with nausea and vomiting.
- **Liver problems.** Tasigna can increase your risk of liver problems. People who have had liver problems in the past may be at risk for getting liver problems with Tasigna. Call your healthcare provider or get medical help right away if you develop any symptoms of liver problems including:
 - stomach area (abdominal) pain
 - yellow skin and eyes
 - dark-colored urine
- **Tumor Lysis Syndrome (TLS).** TLS is caused by a fast breakdown of cancer cells. Your healthcare provider may do blood tests to check you for TLS. TLS can cause you to have:
 - **kidney failure and the need for dialysis treatment**
 - **an abnormal heart beat**
- **Bleeding problems.** Serious bleeding problems and death have happened during treatment with Tasigna. Tell your healthcare provider right away if you develop any signs and symptoms of bleeding during treatment with Tasigna.
- **Fluid retention.** Your body may hold too much fluid (fluid retention). Symptoms of fluid retention include shortness of breath, rapid weight gain, and swelling.
- **Abnormal growth or development in children.** Effects on growth and development have happened in children with chronic phase Ph+ CML during treatment with Tasigna. Some children and adolescents may have slower than normal growth during treatment with Tasigna.

The most common side effects of Tasigna in adults and children include:

- nausea
- rash
- headache
- tiredness
- itching
- vomiting
- diarrhea
- cough
- constipation
- muscle and joint pain
- runny or stuffy nose, sneezing, sore throat
- fever
- night sweats

Side effects in adult patients attempting treatment free remission:

If you and your healthcare provider decide that you can stop taking Tasigna and try treatment free remission (TFR), you may have more muscle and bone (musculoskeletal) symptoms than before you stopped treatment. Symptoms may include:

- muscle pain
- arm and leg pain
- joint pain
- bone pain
- spine pain

Tell your healthcare provider if you or your child have any side effect that bothers you or does not go away.

These are not all of the possible side effects of Tasigna.

Call your doctor for medical advice about side effects. You may report side effects to FDA at 1-800-FDA-1088.

How should I store Tasigna?

- Store Tasigna at room temperature between 68°F to 77°F (20°C to 25°C).
- Safely throw away medicine that is out of date or no longer needed.

Keep Tasigna and all medicines out of the reach of children.

General information about the safe and effective use of Tasigna.

Medicines are sometimes prescribed for purposes other than those listed in a Medication Guide. Do not use Tasigna for a condition for which it was not prescribed. Do not give Tasigna to other people, even if they have the same symptoms that you have. It may harm them. You can ask your pharmacist or healthcare provider for information about Tasigna that is written for health professionals.

What are the ingredients in Tasigna?

Active ingredient: nilotinib

Inactive ingredients: colloidal silicon dioxide, crospovidone, lactose monohydrate, magnesium stearate and poloxamer 188.

The capsules contain gelatin, iron oxide (red), iron oxide (yellow), iron oxide (black), and titanium dioxide.

Distributed by: Novartis Pharmaceuticals Corporation, East Hanover, New Jersey 07936

© Novartis

For more information, go to www.Tasigna.com or call 1-866-411-8274.

This Medication Guide has been approved by the U.S. Food and Drug Administration.

Revised: September 2019

PRODUCT MONOGRAPH

Pr **TECFIDERA**[®]

Dimethyl fumarate delayed-release capsules

120 mg and 240 mg

Antineoplastic and Immunomodulating Agents

Biogen Canada Inc.
90 Burnhamthorpe Road West, Suite 1100
Mississauga, Ontario
L5B 3C3

Date of Initial Approval:
March 28, 2013

Date of Revision:
November 28, 2019

Submission Control No: 231004

Table of Contents

PART I: HEALTH PROFESSIONAL INFORMATION.....	3
SUMMARY PRODUCT INFORMATION	3
INDICATIONS AND CLINICAL USE.....	3
CONTRAINDICATIONS	4
WARNINGS AND PRECAUTIONS.....	4
ADVERSE REACTIONS	10
DRUG INTERACTIONS.....	15
DOSAGE AND ADMINISTRATION.....	16
OVERDOSAGE	18
ACTION AND CLINICAL PHARMACOLOGY	18
STORAGE AND STABILITY.....	20
SPECIAL HANDLING INSTRUCTIONS	21
DOSAGE FORMS, COMPOSITION AND PACKAGING	21
PART II: SCIENTIFIC INFORMATION.....	22
PHARMACEUTICAL INFORMATION	22
CLINICAL TRIALS.....	23
DETAILED PHARMACOLOGY	26
TOXICOLOGY	27
REFERENCES	30
PART III: CONSUMER INFORMATION	31

Pr **TECFIDERA**[®]

Dimethyl fumarate

PART I: HEALTH PROFESSIONAL INFORMATION

SUMMARY PRODUCT INFORMATION

Route of Administration	Dosage Form / Strength	Nonmedicinal Ingredients
Oral	Delayed-release capsules / 120 mg and 240 mg	Colloidal silicon dioxide, croscarmellose sodium, magnesium stearate, methacrylic acid copolymer (type A), methacrylic acid copolymer dispersion, microcrystalline cellulose, polysorbate 80, silicified microcrystalline cellulose, simethicone, sodium lauryl sulfate, talc, and triethyl citrate. The capsule shell contains black iron oxide, FD&C Blue 1, gelatin, titanium dioxide, and yellow iron oxide.

INDICATIONS AND CLINICAL USE

Adults:

TECFIDERA (dimethyl fumarate) is indicated as monotherapy for the treatment of relapsing remitting multiple sclerosis (MS) to reduce the frequency of clinical exacerbations and to delay the progression of disability.

The efficacy of TECFIDERA in patients with primary progressive multiple sclerosis has not been established.

TECFIDERA should only be prescribed by clinicians who are experienced in the diagnosis and management of multiple sclerosis.

Geriatrics (> 65 years of age):

Clinical studies of TECFIDERA did not include sufficient numbers of patients aged 65 and over to determine whether the safety and efficacy of TECFIDERA may differ in elderly patients compared to younger patients. Physicians who choose to treat geriatric patients should consider that treatment with TECFIDERA in the context of a greater frequency of other concomitant diseases and concomitant drug therapy warrants caution and may necessitate additional or more frequent monitoring (see WARNINGS AND PRECAUTIONS, Special Populations - Geriatrics).

Pediatrics (< 18 years of age):

The safety and efficacy of TECFIDERA in patients younger than 18 years of age have not been evaluated. TECFIDERA is not indicated in patients below 18 years of age.

CONTRAINDICATIONS

Patients who are hypersensitive to this drug or to any ingredient in the formulation or component of the container (see POST MARKET ADVERSE DRUG REACTIONS). For a complete listing, see the DOSAGE FORMS, COMPOSITION AND PACKAGING section of the product monograph.

WARNINGS AND PRECAUTIONS**General**

During treatment with TECFIDERA, simultaneous use of other fumaric acid derivatives (topical or systemic) is not recommended.

Progressive Multifocal Leukoencephalopathy

Cases of progressive multifocal leukoencephalopathy (PML) have occurred in patients treated with TECFIDERA, in the presence of lymphopenia ($<0.91 \times 10^9/L$), including in patients who had not previously taken or were not concomitantly taking either immunosuppressive or immunomodulatory medications (see Adverse Reactions, Post-Marketing Experience). These PML cases have occurred predominantly in the setting of prolonged moderate to severe lymphopenia. PML is an opportunistic viral infection of the brain caused by the JC virus (JCV) that typically only occurs in patients who are immunocompromised, and may lead to death or severe disability.

Physicians should be vigilant for clinical symptoms or MRI findings that may be suggestive of PML. If PML is suspected, TECFIDERA treatment should be suspended until PML has been excluded. Typical symptoms associated with PML are diverse, progress over days to weeks, and include progressive weakness on one side of the body or clumsiness of limbs, disturbance of vision, and changes in thinking, memory, and orientation leading to confusion and personality changes.

There is no known intervention that can reliably prevent PML or adequately treat PML if it occurs. Lymphocyte counts should be monitored in patients taking TECFIDERA and as a precaution, interruption of TECFIDERA should be considered in patients with lymphocyte counts $< 0.5 \times 10^9/L$ persisting for more than 6 months (see WARNINGS AND PRECAUTIONS, Hematologic).

Hematologic

TECFIDERA (dimethyl fumarate) may decrease lymphocyte counts (see ADVERSE DRUG REACTIONS, Abnormal Hematologic and Clinical Chemistry findings). In the MS placebo-controlled trials, mean lymphocyte counts decreased by approximately 30% during the first year of treatment with TECFIDERA then remained stable at this reduced level for the duration of treatment. Six percent (6%) of TECFIDERA patients and $< 1\%$ of placebo patients experienced lymphocyte counts $< 0.5 \times 10^9/L$ (lower limit of normal $0.91 \times 10^9/L$). In controlled and uncontrolled clinical trials, 9% of patients had lymphocyte counts $\geq 0.5 \times 10^9/L$ and $< 0.8 \times 10^9/L$ for at least six months. 2% of patients experienced lymphocyte counts $< 0.5 \times 10^9/L$ for at least 6 months and in this

group, the majority of lymphocyte counts remained $< 0.5 \times 10^9/L$ with continued therapy.

Four weeks after stopping TECFIDERA, mean lymphocyte counts increased but did not return to baseline. The time to recovery to baseline lymphocyte counts has not been established.

The following precautions should be taken:

- Prior to initiating treatment with TECFIDERA, obtain a complete blood count (CBC), including lymphocytes, if no recent (within 6 months) result is available. A CBC, including lymphocytes, is also recommended after 6 months of treatment, then every 6 to 12 months, and as clinically indicated.
- Consider interruption of TECFIDERA in patients with lymphocyte counts $< 0.5 \times 10^9/L$ persisting for more than 6 months. Given that the time to lymphocyte recovery has not been established, lymphocyte counts should be followed until recovery.
- Assess the benefit-risk in patients that experience moderate lymphopenia for more than 6 months.
- A CBC is also recommended prior to switching patients to other therapies that are known to reduce lymphocyte counts to avoid additive immune effects (see ADVERSE REACTIONS, Abnormal Hematologic and Clinical Chemistry Findings).
- Patients with pre-existing low lymphocyte counts, and patients concomitantly taking other immunomodulating treatments, were excluded from the multiple sclerosis clinical trials. Treatment is not recommended in patients who are immunocompromised due to other treatments (e.g., anti-neoplastic, immunosuppressive or immune modulating therapies) or disease (e.g., immunodeficiency syndrome), due to the potential risk of additive immune system effects.

Vascular Disorders

TECFIDERA may cause flushing (e.g. flushing, hot flush, warmth, redness, itching, and/or burning sensation). In placebo controlled clinical trials in patients with multiple sclerosis, 34% of TECFIDERA treated patients, compared to 5% of patients that received placebo, experienced flushing. Flushing symptoms generally began soon after initiating TECFIDERA and usually improved or resolved over time (see ADVERSE REACTIONS, Clinical Trial Adverse Drug Reactions). In the majority of patients who experienced flushing, it was mild or moderate in severity. For patients experiencing severe flushing reactions the possibility of hypersensitivity or anaphylactoid reactions should be considered (see WARNINGS AND PRECAUTIONS, Immune, Hypersensitivity; ADVERSE REACTIONS, Post Market Adverse Reactions).

Administration of TECFIDERA with food, administration of 325 mg non-enteric coated acetylsalicylic acid prior to dosing, or a temporary dose reduction to 240 mg/day may reduce the incidence of flushing (see DOSAGE AND ADMINISTRATION, Recommended Dose and Dose Adjustment). The long-term use of acetylsalicylic acid is not recommended for the management of flushing (see DRUG INTERACTIONS).

Gastrointestinal Disorders

TECFIDERA may cause gastrointestinal adverse events. In placebo controlled clinical trials in patients with multiple sclerosis, 48% of patients treated with TECFIDERA compared to 36% of patients that received placebo, experienced gastrointestinal adverse events. The increased frequency of gastrointestinal adverse events with TECFIDERA was mainly due to higher frequencies of nausea,

vomiting, diarrhea, abdominal pain, upper abdominal pain, and dyspepsia. Gastroenteritis was also reported more frequently in patients treated with TECFIDERA than in patients who received placebo (see ADVERSE REACTIONS, Clinical Trial Adverse Drug Reactions).

Administration of TECFIDERA with food or a temporary dose reduction to 240 mg/day may improve tolerability in patients who experience gastrointestinal adverse events (see DOSAGE AND ADMINISTRATION, Recommended Dose and Dose Adjustment).

TECFIDERA has not been evaluated in patients with severe active gastrointestinal disease and caution should be exercised when treating these patients.

Immune

Infections: Treatment with TECFIDERA should not be initiated in patients with signs and symptoms of a serious infection.

Decreases in lymphocyte counts observed in patients treated with TECFIDERA in clinical trials were not associated with increased frequencies of infections. However, due to the potential risk of infections in patients who develop sustained lymphopenia, patients should be instructed to report symptoms of infection to their physician. For patients with signs and symptoms of serious infections, interrupting treatment with TECFIDERA should be considered, until the infection(s) resolves.

Herpes Zoster Infections: Cases of herpes zoster have occurred with TECFIDERA. The majority of cases were non-serious, however, serious cases, including disseminated herpes zoster, herpes zoster ophthalmicus, herpes zoster meningoencephalitis and herpes zoster meningomyelitis have been reported. These events may occur at any time during treatment. Monitor patients taking TECFIDERA for signs and symptoms of herpes zoster. If herpes zoster occurs, appropriate treatment for herpes zoster should be administered. Consider withholding TECFIDERA treatment in patients with serious infections until the infection has resolved (See ADVERSE REACTIONS, Post Market Adverse Drug Reactions).

Vaccination: The safety of administration of live attenuated vaccines during treatment with TECFIDERA has not been evaluated in clinical trials. Live vaccines have a potential risk of clinical infection and are not recommended during treatment with TECFIDERA. The efficacy of live attenuated vaccines administered during treatment with TECFIDERA has not been evaluated in clinical trials.

Hypersensitivity and Anaphylactic Reactions: In clinical trials, 3 patients out of a total of 2,560 patients treated with TECFIDERA experienced serious flushing symptoms that were probable hypersensitivity or anaphylactoid reactions. These events were not life-threatening, but led to hospitalization. Cases of hypersensitivity, angioedema and anaphylactic reaction have been reported during the post marketing period (see ADVERSE REACTIONS, Post Market Adverse Drug Reactions). These reactions generally occurred after the first dose, but may occur at any time during treatment, and may be serious and life threatening. Prescribers and patients should be alert to this possibility in the event of severe flushing reaction. Patients should be instructed to discontinue TECFIDERA and seek immediate medical care should they experience signs and symptoms of anaphylaxis or angioedema. Treatment should not be restarted.

Hepatic/Biliary

During clinical trials in patients with multiple sclerosis, elevations in liver transaminases (ALT and AST) > 1 x the upper limit of normal (ULN) and less than 3 x ULN occurred more frequently in patients treated with TECFIDERA than in patients that received placebo. The increased incidence of elevations of hepatic transaminases in patients treated with TECFIDERA relative to placebo was primarily seen during the first 6 months of treatment (see ADVERSE REACTIONS, Hepatic Transaminases).

Prior to initiating treatment with TECFIDERA, serum aminotransferase, alkaline phosphatase and total bilirubin levels should be obtained (within 6 months). During treatment, evaluation of transaminases is recommended after 6 months of treatment, then every 6 to 12 months, and as clinically indicated. Discontinue TECFIDERA if clinically significant liver injury induced by TECFIDERA is suspected.

Clinically significant cases of liver injury have been reported in patients treated with TECFIDERA in the postmarketing setting. The onset has ranged from a few days to several months after initiation of treatment with TECFIDERA. Signs and symptoms of liver injury, including elevation of serum aminotransferases to greater than 5-fold the upper limit of normal and elevation of total bilirubin to greater than 2-fold the upper limit of normal have been observed. These abnormalities resolved upon treatment discontinuation. Some cases required hospitalization. None of the reported cases resulted in liver failure, liver transplant, or death. However, the combination of new serum aminotransferase elevations with increased levels of bilirubin caused by drug-induced hepatocellular injury is an important predictor of serious liver injury that may lead to acute liver failure, liver transplant, or death in some patients.

Renal

In clinical trials with patients with multiple sclerosis, adverse events of proteinuria (proteinuria, microalbuminuria and urine albumin present) were reported at slightly higher frequencies in patients treated with TECFIDERA compared to patients that received placebo. The significance of these clinical observations is not known at this time.

Prior to initiating treatment with TECFIDERA, urinalysis should be available (within 6 months). During treatment, urinalysis is recommended after 6 months of treatment, then every 6 to 12 months, and as clinically indicated.

The use of TECFIDERA in patients who receive chronic treatment with medications that are associated with potential nephrotoxic risk (e.g., aminoglycosides, diuretics, NSAIDs, lithium) has not

been evaluated. Therefore, caution should be exercised if TECFIDERA is used in patients receiving chronic treatment with such medications.

Special Populations

Hepatic Impairment: The safety of TECFIDERA has not been evaluated in patients with hepatic impairment and it is not known if these patients are at an increased risk of developing elevated liver transaminases, or other adverse events during treatment with TECFIDERA. Caution should be exercised when treating these patients (see WARNINGS AND PRECAUTIONS, Hepatic/Biliary; WARNINGS AND PRECAUTIONS, Monitoring and Laboratory Tests; ADVERSE REACTIONS, Abnormal Hematologic and Clinical Chemistry Findings; DOSAGE AND ADMINISTRATION, Dosing Considerations).

Renal Impairment: The safety of TECFIDERA has not been evaluated in patients with renal impairment and it is not known if these patients are at an increased risk of developing renal adverse events, or other adverse events during treatment with TECFIDERA. Caution should be exercised when treating these patients (see WARNINGS AND PRECAUTIONS, Renal, Monitoring and Laboratory Tests; ADVERSE REACTIONS, Clinical Trial Adverse Drug Reactions, Abnormal Hematologic and Clinical Chemistry Findings; DOSAGE AND ADMINISTRATION, Dosing Considerations).

Pregnant Women: There are no adequate and well-controlled studies of TECFIDERA in pregnant women. The use of TECFIDERA during pregnancy should only be considered if the potential benefit to the mother justifies the potential risk to the fetus.

Monomethyl fumarate was detected in rat and rabbit fetal plasma after oral dimethyl fumarate administration to the mothers. Administration of dimethyl fumarate to rats and rabbits at doses up to 11 and 16 times the recommended human dose (RHD) (AUC basis), respectively, have revealed no evidence of teratogenicity. There were no fertility effects in male and female rats at exposures of 9 and 6 times the RHD, respectively (based on mg/m²). Embryo-fetal toxicity that may have been secondary to maternal toxicity was observed when dimethyl fumarate was given during the period of organogenesis. Adverse effects were observed in offspring when dimethyl fumarate was administered during the pre- and post-natal periods, with the no effect dose at 4 times the RHD on an AUC basis (see TOXICOLOGY).

Nursing Women: It is not known whether dimethyl fumarate or its metabolites are excreted in human milk. Because many drugs are excreted in human milk, caution should be exercised when TECFIDERA is administered to a nursing woman.

Pediatrics (< 18 years of age): The safety and efficacy of TECFIDERA in patients younger than 18 years of age have not been evaluated. TECFIDERA is not indicated in patients below 18 years of age.

Geriatrics (> 65 years of age): Clinical studies of TECFIDERA did not include sufficient numbers of patients aged 65 and over to determine whether the safety and efficacy of TECFIDERA may differ in elderly patients compared to younger patients. Physicians who choose to treat geriatric patients should consider that treatment with TECFIDERA in the context of a greater frequency of other concomitant

diseases and concomitant drug therapy warrants caution and may necessitate additional or more frequent monitoring (see ACTION AND CLINICAL PHARMACOLOGY, Special Populations - Geriatrics).

Monitoring and Laboratory Tests

Prior to initiating treatment, a recent complete blood count (CBC), including lymphocytes, (i.e. within 6 months) is recommended to identify patients with pre-existing low lymphocyte counts, as TECFIDERA may decrease lymphocyte counts (see WARNINGS AND PRECAUTIONS, Hematologic; ADVERSE DRUG REACTIONS, Abnormal Hematologic and Clinical Chemistry Findings). A CBC, including lymphocytes, is recommended after 6 months, then every 6 to 12 months, and as clinically indicated (see WARNINGS AND PRECAUTIONS, Hematologic; ADVERSE DRUG REACTIONS, Abnormal Hematologic and Clinical Chemistry Findings).

Urinalysis should be performed before initiating treatment with TECFIDERA, after 6 months of treatment, then every 6 to 12 months, and as clinically indicated (see WARNINGS AND PRECAUTIONS, Renal; ADVERSE DRUG REACTIONS, Clinical Trial Adverse Drug Reactions, Abnormal Hematologic and Clinical Chemistry Findings).

Liver transaminases should be checked (within 6 months) before initiating treatment with TECFIDERA. During treatment, evaluation of transaminases is recommended after 6 months of treatment, then every 6 to 12 months and as clinically indicated (see WARNINGS AND PRECAUTIONS, Hepatic/Biliary; ADVERSE REACTIONS, Abnormal Hematologic and Clinical Chemistry Findings).

Patient Counselling Information

Consumer information is included in the package of TECFIDERA dispensed to the patient. Patients receiving TECFIDERA should also be given the following information by the physician and/or pharmacist:

1. *General*

Summarize for patients the benefits and potential risks of treatment with TECFIDERA. Tell patients to take TECFIDERA as prescribed. Tell patients not to discontinue TECFIDERA or switch to another therapy without first discussing this with the prescribing physician.

2. *Lymphocyte count decreases*

Inform patients that TECFIDERA may decrease lymphocyte counts. Advise patients that regular blood testing will be performed and that they should contact their physician if they develop symptoms of a serious infection (e.g. pneumonia).

3. *Liver enzyme increases*

Inform patients that TECFIDERA may increase liver enzymes. Advise patients that regular blood testing will be performed.

4. *Protein in urine*

Inform patients that TECFIDERA may increase protein in the urine. Advise patients that regular urine testing will be performed.

5. ***Pregnancy***

Advise women of childbearing age about the use of effective contraception.

6. ***Anaphylactic reaction***

Instructed patients to discontinue TECFIDERA and seek immediate medical care should they experience signs and symptoms of anaphylaxis or angioedema.

7. ***Common adverse events:***

Flushing

Inform patients that TECFIDERA may cause flushing and that it is most common soon after starting treatment. Advise them that taking TECFIDERA with food, temporary dose reduction or administration of 325 mg non-enteric coated acetylsalicylic acid prior to dosing may reduce the incidence of flushing. Advise patients acetylsalicylic acid should not be used long-term for the management of flushing. For patients experiencing severe flushing reactions the possibility of hypersensitivity or anaphylactoid reactions should be considered.

Gastrointestinal events

Inform patients that TECFIDERA may cause gastrointestinal events. Advise them that taking TECFIDERA with food or temporary dose reduction to 240 mg/day may improve tolerability.

8. ***Vaccination***

Advise patients that the use of live attenuated vaccines is not recommended during treatment with TECFIDERA. The effectiveness of live vaccines in patients taking TECFIDERA is unknown.

9. ***Drug interactions***

Inform patients that during treatment with TECFIDERA, simultaneous use of other fumaric acid derivatives (topical or systemic) is not recommended. Advise patients that co-administration of anti-neoplastic, immunosuppressive or immune-modulating therapies is not recommended due to the potential risk of additive immune system effects.

ADVERSE REACTIONS

Adverse Drug Reaction Overview

In the two Phase 3 placebo-controlled trials, 1529 patients received TECFIDERA (dimethyl fumarate) with an overall exposure of 2371 person years. The adverse reactions presented below are based on safety information from 769 patients treated with TECFIDERA 240 mg twice a day and 771 patients treated with placebo.

The most common adverse reactions (incidence > 10%) for patients treated with TECFIDERA were flushing and gastrointestinal (GI) events (i.e., diarrhea, nausea, abdominal pain and abdominal pain upper). In the majority of subjects, the adverse reactions were non-serious in nature. The most commonly reported adverse events leading to discontinuation of treatment (incidence > 1%) in patients treated with TECFIDERA were flushing (3%) and gastrointestinal events (4%).

Clinical Trial Adverse Drug Reactions

Because clinical trials are conducted under very specific conditions the adverse reaction rates observed in the clinical trials may not reflect the rates observed in practice and should not be compared to the rates in the clinical trials of another drug. Adverse drug reaction information from clinical trials is useful for identifying drug-related adverse events and for approximating rates.

Table 1 lists treatment emergent adverse events that occurred during active treatment in $\geq 1\%$ of TECFIDERA-treated patients and at $\geq 1\%$ higher incidence than placebo in the two Phase 3 placebo-controlled trials.

Table 1 – Treatment-Emergent Adverse Events with an Incidence of $\geq 1\%$ of TECFIDERA Treated Patients and at $\geq 1\%$ Higher Rate than for Placebo

Adverse Event	Placebo N=771	TECFIDERA 240 mg BID N=769
Flushing	33 (4.3%)	265 (34.5%)
Nasopharyngitis	159 (20.6%)	170 (22.1%)
Diarrhea	83 (10.8%)	107 (13.9%)
Urinary Tract Infection	95 (12.3%)	107 (13.9%)
Upper Respiratory Tract Infection	87 (11.3%)	99 (12.9%)
Nausea	67 (8.7%)	93 (12.1%)
Abdominal Pain Upper	45 (5.8%)	76 (9.9%)
Abdominal Pain	37 (4.8%)	73 (9.5%)
Proteinuria	59 (7.7%)	67 (8.7%)
Vomiting	37 (4.8%)	65 (8.5%)
Pruritus	30 (3.9%)	62 (8.1%)
Rash	26 (3.4%)	58 (7.5%)
Hot Flush	16 (2.1%)	52 (6.8%)
Albumin Urine Present	27 (3.5%)	46 (6.0%)
Alanine Aminotransferase Increased	38 (4.9%)	45 (5.9%)
Gastroenteritis	28 (3.6%)	42 (5.5%)
Erythema	10 (1.3%)	36 (4.7%)
Dyspepsia	20 (2.6%)	35 (4.6%)
Microalbuminuria	24 (3.1%)	35 (4.6%)
Aspartate Aminotransferase Increased	18 (2.3%)	33 (4.3%)
Gastritis	11 (1.4%)	22 (2.9%)
Burning Sensation	13 (1.7%)	21 (2.7%)
Abdominal Discomfort	11 (1.4%)	19 (2.5%)
Gastrointestinal Disorder	8 (1.0%)	18 (2.3%)
Lymphopenia	2 (0.3%)	18 (2.3%)
Blood Urine Present	7 (0.9%)	16 (2.1%)
Dry Mouth	6 (0.8%)	16 (2.1%)

Adverse Event	Placebo N=771	TECFIDERA 240 mg BID N=769
Blood Parathyroid Hormone Increased	6 (0.8%)	15 (2.0%)
Feeling Hot	2 (0.3%)	15 (2.0%)
Rhinorrhoea	8 (1.0%)	15 (2.0%)
Dermatitis Allergic	5 (0.6%)	13 (1.7%)
White Blood Cell Count Decreased	1 (0.1%)	13 (1.7%)
Dysaesthesia	5 (0.6%)	12 (1.6%)
Hypersensitivity	2 (0.3%)	11 (1.4%)
Weight Decreased	3 (0.4%)	11 (1.4%)
Otitis Media	1 (0.1%)	10 (1.3%)
Lymphocyte Count Decreased	1 (0.1%)	9 (1.2%)

Flushing: In the placebo-controlled trials, 34% of TECFIDERA treated patients, compared to 5% of patients that received placebo, experienced flushing adverse events. The incidence of flushing adverse events (e.g., flushing, hot flush, warmth, redness, itching, burning sensation) was higher early in the course of treatment (primarily in month 1) and decreased over time. The majority of flushing adverse events were mild-to-moderate in severity. Overall, 3% of patients treated with TECFIDERA compared to < 1% on placebo discontinued treatment due to flushing. The incidence of serious flushing which may be characterized by generalized erythema, rash and/or pruritus was seen in less than 1% of patients treated with TECFIDERA (see WARNINGS AND PRECAUTIONS, Vascular and DOSAGE AND ADMINISTRATION).

Gastrointestinal: In placebo controlled clinical trials, 48% of patients treated with TECFIDERA compared to 36% of patients that received placebo, experienced gastrointestinal adverse events. The incidence of GI related adverse events (e.g. nausea, vomiting, diarrhea, abdominal pain, upper abdominal pain & dyspepsia) was higher early in the course of treatment (primarily in month 1) and usually decreased over time in patients treated with TECFIDERA compared with placebo. Four percent (4%) of patients treated with TECFIDERA and less than 1% of placebo treated patients discontinued due to gastrointestinal adverse events. The incidence of individual serious GI events, including gastroenteritis and gastritis, was less than 1% of patients treated with TECFIDERA (see WARNINGS AND PRECAUTIONS, Gastrointestinal Disorders and DOSAGE AND ADMINISTRATION)

Infections: The incidence of infections (60% vs. 56%) and serious infections (2% vs. 1%) was similar in patients treated with TECFIDERA or placebo, respectively (see WARNINGS AND PRECAUTIONS, Hematologic, Infections; ADVERSE REACTIONS, Abnormal Hematologic and Clinical Chemistry Findings).

Hepatic Transaminases: In placebo-controlled trials, elevations of hepatic transaminases were observed. The majority of patients with elevations had hepatic transaminases that were less than 3 times the upper limit of normal (ULN). Alanine aminotransferase (ALT) > 1 x ULN and < 3 x ULN occurred in 42% of patients treated with TECFIDERA compared to 31% of patients on placebo. Aspartate aminotransferase (AST) > 1 x ULN and < 3 x ULN occurred in 24% of patients treated with TECFIDERA compared to 19% of patients on placebo. The increased incidence of elevations of

hepatic transaminases in patients treated with TECFIDERA relative to placebo was primarily seen during the first 6 months of treatment. Discontinuation of treatment due to elevated hepatic transaminases were < 1% and similar in patients treated with TECFIDERA or placebo. Elevations in transaminases ≥ 3 times ULN with concomitant elevations in total bilirubin > 2 times ULN were not observed during placebo-controlled studies (see WARNINGS AND PRECAUTIONS, Hepatic/Biliary, Monitoring and Laboratory Tests; ADVERSE DRUG REACTIONS, Abnormal Hematologic and Clinical Chemistry Findings).

Renal: Adverse events of proteinuria (proteinuria, microalbuminuria and urine albumin present) were reported at slightly higher frequencies in patients treated with TECFIDERA compared to patients that received placebo (Table 1). The overall incidence of renal and urinary adverse events, including serious adverse events and adverse events leading to discontinuation, was similar for TECFIDERA and placebo-treated patients. There were no reports of serious renal failure. On urinalysis, the percentage of patients with protein values of 1+ or greater was similar for TECFIDERA (43%) and placebo-treated patients (40%). Typically, laboratory observations of proteinuria were not progressive. Positive urine ketones occurred more frequently in patients treated with TECFIDERA than in patients who received placebo, but were not associated with increases in other renal/urinary adverse events (see ADVERSE DRUG REACTIONS, Abnormal Hematologic and Clinical Chemistry Findings).

Abnormal Hematologic and Clinical Chemistry Findings

Abnormal hematological and clinical chemistry findings reported in the placebo controlled multiple sclerosis clinical trials included the following:

Hematologic

- The majority of patients (> 98%) had normal lymphocyte values prior to initiating treatment. Upon treatment with TECFIDERA, lymphocytes counts decreased over the first year with a subsequent plateau. On average, lymphocyte counts decreased by approximately 30% from baseline value, but mean and median lymphocyte counts remained within normal limits. Patients with lymphocyte counts < $0.5 \times 10^9/L$ were observed in < 1% of patients treated with placebo and 6% of patients treated with TECFIDERA. In controlled and uncontrolled clinical studies, 9% of patients had lymphocyte counts $\geq 0.5 \times 10^9/L$ and < $0.8 \times 10^9/L$ for at least six months. 2% of patients experienced lymphocyte counts < $0.5 \times 10^9/L$ for at least 6 months and in this group, the majority of lymphocyte counts remained < $0.5 \times 10^9/L$ with continued therapy.
- A transient increase in mean eosinophil counts was seen during the first 2 months of TECFIDERA therapy (see WARNINGS AND PRECAUTIONS, Hematologic).

Clinical Chemistry

- In the placebo-controlled studies, measurement of urinary ketones (1+ or greater) was higher in patients treated with TECFIDERA (45%) compared to placebo (10%). No untoward clinical consequences were observed in clinical trials (see ADVERSE REACTIONS, Renal).
- Levels of 1,25-dihydroxyvitamin D decreased in TECFIDERA treated patients relative to placebo (median percentage decrease from baseline at 2 years of 25% versus 15%, respectively) and levels of parathyroid hormone (PTH) increased in TECFIDERA treated patients relative to placebo (median percentage increase from baseline at 2 years of 29% versus 15%, respectively). Mean values for both parameters remained within normal range. No untoward clinical consequences were observed in clinical trials.

Less Common Clinical Trial Adverse Events (< 1%)

The following is a list of treatment-emergent adverse events reported by patients treated with TECFIDERA at any dose in MS placebo-controlled trials (n=1720) at an incidence of < 1% but at an incidence of $\geq 0.3\%$ higher than placebo (n=836). Events that have already been included in Table 1 have been excluded. Although the events reported occurred during treatment with TECFIDERA, they were not necessarily caused by TECFIDERA.

Events are listed by system organ class in decreasing order of incidence in TECFIDERA-treated patients.

Blood and lymphatic system: eosinophilia

Cardiac disorders: supraventricular extrasystoles, atrioventricular block first degree, angina pectoris

Gastrointestinal disorders: periodontitis, dental caries, food poisoning, defaecation urgency, eructation

General disorders: non-cardiac chest pain, malaise

Hepatobiliary disorders: liver disorder

Immune system disorders: food allergy

Infections and infestations: conjunctivitis infective, cellulitis, tracheitis

Injury, poisoning and procedural complications: foot fracture, ankle fracture

Investigations: beta 2 microglobulin increased, neutrophil count decreased, blood potassium increased

Metabolism and nutrition disorders: hypercholesterolaemia

Musculoskeletal and connective tissue disorders: arthritis, joint stiffness

Neoplasms benign, malignant and unspecified: skin papilloma, lipoma, breast cancer (events occurred during open-label extension studies)

Nervous system disorders: dysgeusia, dysarthria, migraine with aura, cognitive disorder

Psychiatric disorders: mood altered

Renal and urinary disorders: urge incontinence

Reproductive system and breast disorders: breast pain

Respiratory, thoracic and mediastinal disorders: sinus congestion, asthma

Skin and subcutaneous tissue disorders: rash pruritic, skin burning sensation, rash macular, generalised erythema, rash generalised, photosensitivity reaction, rash erythematous

Vascular disorders: hyperaemia, varicose vein

Post Market Adverse Drug Reactions

During post marketing experience, hypersensitivity reactions have been reported, including rare reports of anaphylaxis and angioedema in patients treated with TECFIDERA. Signs and symptoms have included difficulty breathing, urticaria, and swelling of the throat and tongue.

Progressive multifocal leukoencephalopathy has occurred in the setting of lymphopenia ($<0.91 \times 10^9/L$) following TECFIDERA administration. These PML cases have occurred predominantly in the setting of prolonged moderate to severe lymphopenia.

Liver function abnormalities (elevations in transaminases ≥ 3 times ULN with concomitant elevations in total bilirubin > 2 times ULN) have been reported following TECFIDERA administration in post marketing experience. These abnormalities resolved upon treatment discontinuation.

Herpes zoster infection has been reported with TECFIDERA administration in post marketing experience. The majority of cases were non serious.

DRUG INTERACTIONS

Overview

In humans, TECFIDERA (dimethyl fumarate) is extensively metabolized by esterases before it reaches the systemic circulation and further metabolism occurs through tricarboxylic acid (TCA) cycle, with no involvement of the cytochrome P450 (CYP) system. Potential drug interaction risks were not identified from *in vitro* CYP-inhibition and induction studies, a p-glycoprotein study, or studies of the protein binding of dimethyl fumarate and monomethyl fumarate (MMF, a major metabolite of dimethyl fumarate).

Drug-Drug Interactions

During treatment with TECFIDERA, simultaneous use of other fumaric acid derivatives (topical or systemic) is not recommended.

Single doses of drugs used in patients with multiple sclerosis, intramuscular interferon beta-1a and glatiramer acetate (GA), were clinically tested for potential drug-interactions with TECFIDERA and did not alter the pharmacokinetic profile of TECFIDERA. TECFIDERA is not indicated for concomitant use with these drugs.

Non-enteric coated acetylsalicylic acid 325 mg, when administered approximately 30 minutes before TECFIDERA, over 4 days of dosing in healthy adult volunteers, did not alter the pharmacokinetic profile of TECFIDERA, and reduced the occurrence and severity of flushing. Long-term use of acetylsalicylic acid is not recommended for the management of flushing. Potential risks associated with acetylsalicylic acid therapy should be considered prior to co-administration with TECFIDERA.

In a 2-period cross-over pharmacokinetic study in healthy female subjects (n=40), co-administration of TECFIDERA for 21 days (240 mg BID) with a monophasic combined oral contraceptive (250 µg norgestimate and 35 µg ethinyl estradiol) did not elicit any relevant effects on oral contraceptive

exposure (Day 21). No interaction studies have been performed with oral contraceptives containing other progestogens, however an effect of TECFIDERA on their exposure is not expected, based on *in vitro* CYP induction studies (see **Overview**).

Pharmacodynamic interactions

Anti-neoplastic, immunosuppressive or immune modulating drugs: TECFIDERA has not been studied in patients treated with anti-neoplastic or immunosuppressive therapies and concomitant treatment is not recommended in these patients due to the potential risk of additive immune system effects. Caution should also be exercised when switching patients from long-acting therapies with immune effects to avoid additive immune system effects (see WARNINGS AND PRECAUTIONS, Hematologic).

Vaccines: The use of live attenuated vaccines may carry the risk of infection and is not recommended. No clinical data are available on the efficacy and safety of live attenuated vaccines in patients taking TECFIDERA.

Drugs associated with nephrotoxicity: The use of TECFIDERA in patients who receive chronic treatment with drugs that are associated with potential nephrotoxic risk (e.g., aminoglycosides, diuretics, NSAIDs, lithium) has not been evaluated. Therefore, caution should be exercised if TECFIDERA is used in these patients (see WARNINGS AND PRECAUTIONS, Renal; ADVERSE REACTIONS, Abnormal Hematologic and Clinical Chemistry Findings).

Corticosteroids: In the multiple sclerosis clinical trials, relapses were treated with a short course of corticosteroids. Although this was not associated with an increased rate of infection in clinical trials, patients should be reminded of the potential increased risk of infection due to additive immune system effects of corticosteroids.

Drug-Food Interactions

Food does not have a clinically significant effect on exposure of TECFIDERA. TECFIDERA may be taken with or without food.

Drug-Laboratory Interactions

Not applicable.

DOSAGE AND ADMINISTRATION

Dosing Considerations

Dosing in special populations:

Renal or hepatic impairment: TECFIDERA (dimethyl fumarate) has not been studied in patients with renal or hepatic impairment. Based on the pharmacokinetics and metabolic fate of TECFIDERA in healthy adults, neither condition would be expected to affect exposure to MMF and therefore no dosage adjustment is necessary. However, caution should be exercised when treating patients with these conditions (see WARNINGS AND PRECAUTIONS, Special Populations; ACTION AND

CLINICAL PHARMACOLOGY, Pharmacokinetics, Special Populations and Conditions).

Pediatric patients: TECFIDERA is not indicated for use in pediatric patients (see INDICATIONS AND CLINICAL USE).

Geriatric patients: Clinical studies of TECFIDERA had limited exposure to patients aged 55 years and above, and did not include sufficient numbers of patients aged 65 and over to determine whether the safety and efficacy of TECFIDERA differs in elderly patients compared to younger patients. Based on the mechanism of action there are no theoretical reasons for any requirement for dose adjustments in the elderly. Physicians who choose to treat geriatric patients should consider that treatment with TECFIDERA in the context of a greater frequency of other concomitant diseases and concomitant drug therapy warrants caution and may necessitate additional or more frequent monitoring (see WARNINGS AND PRECAUTIONS, Special Populations).

Recommended Dose and Dosage Adjustment

Initial dose: The starting dose for TECFIDERA is 120 mg twice a day orally, for a total of 240 mg per day.

Usual dose: After 7 days, increase to the recommended dose of 240 mg twice a day orally, for a total of 480 mg per day.

Temporary dose reduction to 120 mg twice a day (total of 240 mg per day) may reduce the occurrence of flushing and gastrointestinal (GI) side effects. Within one month, the recommended dose of 240 mg twice a day orally should be resumed.

TECFIDERA can be taken with or without food. For those patients who may experience gastrointestinal side effects, taking TECFIDERA with food may improve tolerability.

Administration of 325 mg non-enteric coated acetylsalicylic acid prior to TECFIDERA dosing reduced the occurrence and severity of flushing in a 4-day healthy volunteer study. Longer term use of acetylsalicylic acid to manage flushing has not been studied and is not recommended (see ACTION AND PHARMACOLOGY).

Administration

TECFIDERA is taken orally, with or without food.

Capsules should be taken by swallowing whole. The capsule and its contents should not be crushed, divided, or dissolved, as the enteric-coating of the microtablets in the capsule helps to prevent irritant effects on the stomach.

Missed Dose

If a dose is missed, the missed dose can be taken if there is at least 4 hours between the morning and evening doses. Otherwise, treatment should be continued with the next dose as planned.

OVERDOSAGE

For management of a suspected drug overdose, contact your regional Poison Control Centre.

Cases of overdose with TECFIDERA have been reported. The symptoms described in these cases were consistent with the known adverse event profile of TECFIDERA. There are no known therapeutic interventions to enhance elimination of TECFIDERA nor is there a known antidote. In the event of overdose, it is recommended that symptomatic supportive treatment be initiated as clinically indicated. Safety of cumulative doses higher than 720 mg daily has not been adequately evaluated (see ACTION AND CLINICAL PHARMACOLOGY, Pharmacokinetics).

ACTION AND CLINICAL PHARMACOLOGY

Mechanism of Action

Dimethyl fumarate (DMF) and the metabolite, monomethyl fumarate (MMF), have been shown to activate the Nuclear factor (erythroid-derived 2)-like 2 (Nrf2) pathway *in vitro* and *in vivo* in animals and humans. The Nrf2 pathway is involved in the cellular response to oxidative stress. Dimethyl fumarate has also demonstrated anti-inflammatory effects *in vitro* and *in vivo*. The mechanism by which TECFIDERA (dimethyl fumarate) exerts therapeutic effects in multiple sclerosis is not-known.

Pharmacodynamics

The primary pharmacodynamic response to TECFIDERA treatment appears to be mediated, in part, through activation of the Nrf2 pathway. Activation of the Nrf2 pathway leads to the upregulation of antioxidant response genes. Studies done *in vitro* and *in vivo* in animals suggest that the Nrf2 dependent upregulation of antioxidant response genes by DMF and/or MMF can protect various types of cells and tissues, including some from the CNS, from experimental toxic oxidative stress.

Dimethyl fumarate has demonstrated anti-inflammatory effects *in vitro*, with a reduction in pro-inflammatory cytokine and chemokine production that was stimulated by activation of the TLR-4 pathway via LPS administration. Additionally, a mechanistic role for dimethyl fumarate has been identified in inducing type II dendritic cells and biasing immune cell differentiation towards an anti-inflammatory TH2 phenotype. These anti-inflammatory responses are thought to reduce aberrant immune cell activation, which occurs in auto-immune diseases such as MS. These anti-inflammatory effects observed *in vitro* were consistent with *in vivo* studies. In the Phase 3 clinical trials mean lymphocyte counts decreased by approximately 30% from baseline values during the first year and remained stable at the reduced level.

An analysis over a 4-day dosing period, in healthy adult volunteers, indicated that flushing scores decreased from a maximum on the first day of dosing, despite higher plasma MMF concentrations at the final dose. Administration of non-enteric coated acetylsalicylic acid 325 mg, 30 minutes prior to dosing, attenuated flushing (see DOSAGE AND ADMINISTRATION).

In a clinical study in patients with relapsing forms of MS, patients treated with TECFIDERA and non-pegylated interferons mounted comparable immune responses to recall antigen (re-exposure with tetanus toxoid) inactivated neoantigen (first vaccination with conjugated meningococcal

C polysaccharide vaccine), while the immune response to different serotypes of an unconjugated 23-valent pneumococcal polysaccharide vaccine varied in both treatment groups. Small numerical differences in the response to tetanus toxoid and pneumococcal serotype 3 polysaccharide were noted in favour of non-pegylated interferon.

Effect on Cardiovascular System: Single doses of 240 mg or 360 mg TECFIDERA did not have any effect on the QTc interval when compared to placebo in a specialized QTc study in healthy subjects.

Pharmacokinetics

Orally administered TECFIDERA undergoes rapid presystemic hydrolysis by esterases and is converted to its primary metabolite, monomethyl fumarate (MMF), which is also active. Dimethyl fumarate is not quantifiable in plasma following oral administration of TECFIDERA. Therefore, all pharmacokinetic analyses related to TECFIDERA were performed with plasma MMF concentrations. Pharmacokinetic data were obtained in subjects with multiple sclerosis and healthy volunteers.

Absorption: TECFIDERA concentration-time profiles are characterized by high inter-individual variability. The T_{max} of TECFIDERA is 2-5 hours. As TECFIDERA microtablets are protected by an enteric coating, absorption does not commence until the microtablets leave the stomach (generally less than 1 hour post-dose). Following 240 mg administered twice a day with food, the median peak (C_{max}) was 1.72 mg/L and overall (AUC) exposure was 8.02 h.mg/L in subjects with MS (C_{max} and AUC increased approximately dose proportionally in the dose range studied (120 mg to 360 mg).

Food does not have a clinically significant effect on exposure of TECFIDERA. Therefore, TECFIDERA may be taken with or without food.

Based on the results of ANOVA, body weight is the main covariate of exposure (by C_{max} and AUC) in relapsing remitting multiple sclerosis (RRMS) subjects, but did not affect safety and efficacy measures evaluated in the clinical studies. Gender and age did not have a statistically significant impact on C_{max} and AUC.

Distribution: The apparent volume of distribution following oral administration of 240 mg TECFIDERA varies between 53 and 73 L in healthy subjects. Human plasma protein binding of MMF generally ranges between 27% - 40%.

Metabolism: In humans, TECFIDERA is extensively metabolized by esterases, which are ubiquitous in the gastrointestinal tract, blood and tissues, before it reaches the systemic circulation. Further metabolism occurs through the tricarboxylic acid (TCA) cycle, with no involvement of the cytochrome P450 (CYP) system. A single 240 mg ^{14}C -dimethyl fumarate dose study identified monomethyl fumarate, fumaric and citric acid, and glucose as the major metabolites in plasma. The downstream metabolism of fumaric and citric acid occurs through the TCA cycle, with exhalation of CO_2 serving as a primary route of elimination. Less than 0.1% of the dose is excreted as unchanged dimethyl fumarate in urine.

Potential drug interaction risks were not identified for monomethyl fumarate from *in vitro* CYP-inhibition and induction studies, a p-glycoprotein study, or protein binding studies.

Excretion: Exhalation of CO₂ is the primary route of TECFIDERA elimination accounting for approximately 60% of the dose. Renal and fecal elimination are secondary routes of elimination, accounting for 15.5% and 0.9% of the dose respectively.

The terminal half-life of MMF is short (approximately 1 hour) and so no circulating MMF is present at 24 hours in the majority of individuals. Accumulation of MMF does not occur with multiple doses of TECFIDERA at the therapeutic regimen.

Linearity: TECFIDERA exposure increases in an approximately dose proportional manner with single and multiple doses in the 120 to 360 mg dose range studied.

Special Populations and Conditions

Pediatrics: TECFIDERA is not indicated in patients below the age of 18. The pharmacokinetic profile of TECFIDERA 240 mg twice a day was evaluated in a small, open-label, uncontrolled study in patients with RRMS aged 13 to 17 years (n=22; 21 patients of whom were in the pharmacokinetic analysis). The pharmacokinetics of TECFIDERA in these adolescent patients was consistent with that previously observed in adult patients (C_{max}: 2.00±1.29 mg/l; AUC_{0-12hr}: 3.62±1.16 h.mg/l, which corresponds to an overall daily AUC of 7.24 h.mg/l).

Geriatrics: The pharmacokinetics in patients aged 65 and over has not been studied (see WARNINGS AND PRECAUTIONS, Special Populations – Geriatrics).

Body Weight & Gender: Body weight is the main covariate of exposure (by C_{max} and AUC) in relapsing remitting multiple sclerosis (RRMS) subjects, but did not affect safety and efficacy measures evaluated in the clinical studies. Gender and age did not have a statistically significant impact on C_{max}.

Race: Race and ethnicity have no effect on the pharmacokinetics of TECFIDERA.

Hepatic Insufficiency: As dimethyl fumarate and MMF are metabolized by esterases present in most tissues, without the involvement of the CYP450 system, evaluation of pharmacokinetics in individuals with hepatic impairment was not conducted (see WARNINGS AND PRECAUTIONS, Special Populations – Hepatic Impairment).

Renal Insufficiency: Since the renal pathway is a secondary route of elimination for TECFIDERA accounting for less than 16% of the dose administered, evaluation of pharmacokinetics in individuals with renal impairment was not conducted (see WARNINGS AND PRECAUTIONS, Special Populations – Renal Impairment).

STORAGE AND STABILITY

Store TECFIDERA (dimethyl fumarate) capsules between 15 and 30°C in the original packaging in order to protect from light.

SPECIAL HANDLING INSTRUCTIONS

Not applicable.

DOSAGE FORMS, COMPOSITION AND PACKAGING

TECFIDERA is available as enteric-coated microtablets in a hard gelatin capsule containing 120 mg or 240 mg of dimethyl fumarate.

120 mg Capsules: Have a green cap and white body and are printed with “BG-12 120 mg” in black ink.

120 mg Packaging:

14 Capsule Cartons: one folded wallet containing 14 capsules per blister

56 Capsule Cartons: two folded wallets containing two blisters with 14 capsules per blister

The capsules are in a PVC/PE/PVDC aluminum blister sealed inside a folded wallet.

240 mg Capsules: Have a green cap and body and are printed with “BG-12 240 mg” in black ink.

240 mg Packaging: 56 Capsule Cartons: two folded wallets containing two blisters with 14 capsules per blister.

The capsules are in a PVC/PE/PVDC aluminum blister sealed inside a folded wallet.

120 mg non-medicinal ingredients: colloidal silicon dioxide, croscarmellose sodium, magnesium stearate, methacrylic acid copolymer (type A), methacrylic acid copolymer dispersion, microcrystalline cellulose, polysorbate 80, simethicone, sodium lauryl sulfate, talc and triethyl citrate. The capsule shell contains black iron oxide, FD&C Blue 1, gelatin, titanium dioxide and yellow iron oxide.

240 mg non-medicinal ingredients: colloidal silicon dioxide, croscarmellose sodium, magnesium stearate, methacrylic acid copolymer (type A), methacrylic acid copolymer dispersion, polysorbate 80, silicified microcrystalline cellulose, simethicone, sodium lauryl sulfate, talc and triethyl citrate. The capsule shell contains black iron oxide, FD&C Blue 1, gelatin, titanium dioxide and yellow iron oxide.

PART II: SCIENTIFIC INFORMATION

PHARMACEUTICAL INFORMATION

Drug Substance

Proper name: Dimethyl fumarate

Chemical name: Dimethyl (E)-butenedioate

CAS: 624-49-7

Molecular formula and molecular mass: $C_6H_8O_4$, molecular mass 144.13

Structural formula:

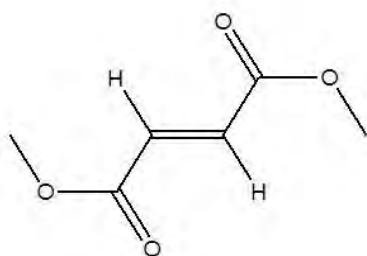

Physicochemical properties: Dimethyl fumarate is a white to off-white powder that is highly soluble in water.

CLINICAL TRIALS

Study demographics and trial design

Table 2- Summary of patient demographics for clinical trials in specific indication

Study #	Trial design	Dosage, route of administration and duration	Study subjects (n=number)	Mean age (Range)	Gender
Study 1 (DEFINE)	Randomized, double-blind, placebo-controlled study.	TECFIDERA 240 mg twice or three times daily, or placebo, (oral). 2 year study.	TECFIDERA BID: n=410 TECFIDERA TID: n=416 Placebo: n=408	39 (18 – 56)	Male: 26% Female: 74%
Study 2 (CONFIRM)	Multicenter, randomized, double-blind, placebo controlled study with a rater-blinded reference comparator of glatiramer acetate (GA).	TECFIDERA 240 mg twice or three times daily or placebo (oral), or GA. 2 year study.	TECFIDERA BID: n=359 TECFIDERA TID: n=345 Placebo: n=363 GA: n=350	37 (18 – 56)	Male: 30% Female: 70%

The efficacy and safety of TECFIDERA (dimethyl fumarate) was demonstrated in two studies that evaluated TECFIDERA taken either twice or three times a day in patients with relapsing-remitting multiple sclerosis (RRMS). The starting dose for TECFIDERA was 120 mg twice or three times a day for the first 7 days, followed by an increase to either 240 mg twice or three times a day. Both studies included patients with Expanded Disability Status Scale (EDSS) scores ranging from 0 to 5, who had experienced at least 1 relapse during the year prior to randomization, or, within 6 weeks of randomization had a brain Magnetic Resonance Imaging (MRI) demonstrating at least one gadolinium+ (Gd+) lesion.

Study 1 (DEFINE): Study 1 was a 2-year randomized, double-blind, placebo-controlled study in 1234 patients with RRMS who had not received interferon-beta or glatiramer acetate (GA) for at least the previous 3 months or natalizumab for at least the previous 6 months. Neurological evaluations were performed at baseline, every 3 months and at time of suspected relapse. MRI evaluations were performed at baseline, month 6, and year 1 and 2. The primary endpoint in Study 1 was the reduction in the proportion of patients relapsed at 2 years.

Patients were randomized to receive TECFIDERA 240 mg twice a day (n=410), TECFIDERA 240 mg three times a day (n=416), or placebo (n=408) for up to 2 years (96 weeks). Median age: 39 years, median years since diagnosis: 4.0 years and median EDSS score at baseline: 2.0. Mean time on study was 84 weeks on 240 mg twice a day, 83 weeks on 240 mg three times a day and 85 weeks on placebo.

The proportion of patients relapsed at 2 years was significantly lower ($p < 0.0001$) in the group treated with TECFIDERA than in the group that received placebo (Table 3, Figure 1).

Clinical secondary endpoints included annualized relapse rate (ARR), and time to 12-week confirmed disability progression at 2 years. Confirmed disability progression was defined as at least a 1 point

increase from baseline EDSS (1.5 point increase for patients with baseline EDSS of 0) sustained for 12 weeks. The annualized relapse rate and time to 12-week confirmed disability progression were reduced in patients treated with TECFIDERA compared to placebo (Table 3).

Secondary MRI endpoints included the number of new or newly enlarging T2 hyperintense lesions and number of Gd-enhancing lesions over 2 years, and both were reduced in patients treated with TECFIDERA compared to patients who received placebo (Table 3).

The 240 mg three times daily dose resulted in no additional benefit over the TECFIDERA 240 mg twice daily dose.

Table 3 – Study 1 (DEFINE) Study Results

	TECFIDERA, 240 mg BID (N=410)	Placebo (N=408)
Primary Endpoint		
Proportion relapsing at 2 years Relative risk reduction (percentage)	0.270 49%	0.461
Secondary Endpoints		
Annualized relapse rate Relative risk reduction (percentage)	0.172 53%	0.364
Proportion with disability progression Relative risk reduction (percentage)	0.164 38%	0.271
Mean number of new or newly enlarging T2 lesions over 2 years Relative reduction (percentage)	2.6 85%	17.0
Mean number of Gd lesions at 2 years (median) Relative odds reduction (percentage)	0.1 (0) 90%	1.8 (0)

Figure 1 - Time to First Relapse in Study 1 (DEFINE) – Percentage of Patients Relapsed at 2 years

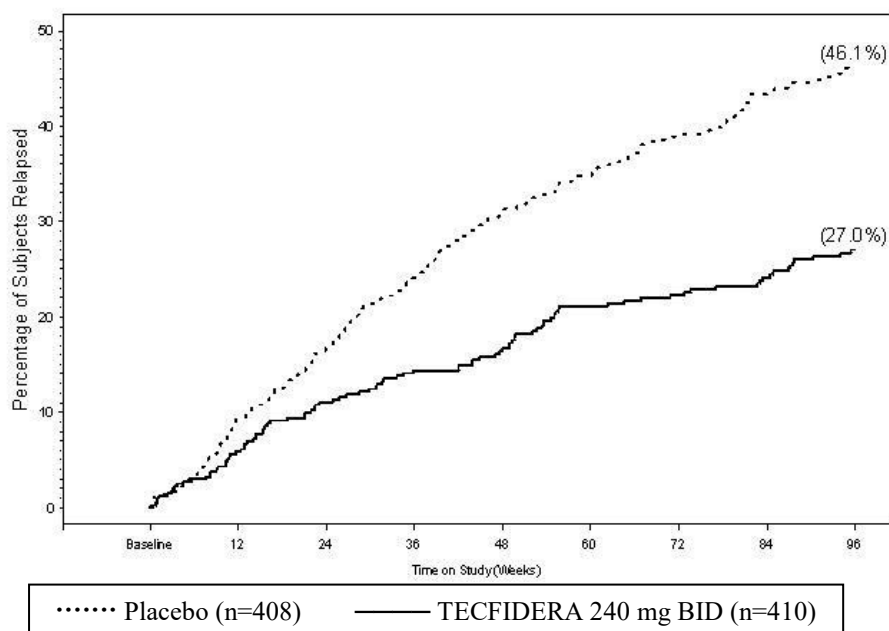

NOTE 1: Only relapses confirmed by the INEC (Independent Neurology Evaluation Committee) were included in the analysis.
 2: Subjects who did not experience a relapse prior to switching to alternative MS medications or withdrawal from study were

censored at the time of switch/withdrawal.

Study 2 (CONFIRM): Study 2 was a 2-year, randomized, double-blind, placebo-controlled study in 1417 patients with RRMS. Study 2 included an open label reference comparator group that received glatiramer acetate (GA). Patients included in the study had not received interferon-beta for at least the previous 3 months, natalizumab for at least the previous 6 months or glatiramer acetate at any time previously. The efficacy and safety evaluations were identical to Study 1 and the endpoints were consistent between the studies. The primary endpoint in Study 2 was the annualized relapse rate at 2 years.

Patients were randomized to receive TECFIDERA 240 mg twice a day (n=359), TECFIDERA 240 mg three times a day (n=345), placebo (n=363) or glatiramer acetate (n=350) for up to 2 years (96 weeks). Median age: 37 years, median years since diagnosis: 3.0 years and median EDSS score at baseline: 2.5. Mean time on study was 84 weeks on TECFIDERA, 86 weeks on placebo and 88 weeks on glatiramer acetate.

The annualized relapse rate at 2 years, was significantly lower in patients treated with TECFIDERA than in patients treated with placebo (0.224 for TECFIDERA vs. 0.401 for placebo, $p < 0.0001$), corresponding to a 44% relative reduction.

Clinical secondary endpoints included the proportion of patients relapsed at 2 years, and time to 12-week confirmed disability progression at 2 years (defined as in Study 1). The proportion of patients relapsed at 2 years was reduced in the TECFIDERA group compared to the placebo group. Time to 12-week confirmed disability progression was not significantly reduced for patients on TECFIDERA compared to those on placebo (Table 4).

Secondary MRI endpoints included the number of new or newly enlarging T2 hyperintense lesions and number new of T1 hypointense lesions at 2 years, and both were reduced in patients treated with TECFIDERA compared to those on placebo (Table 4).

Table 4 - Study 2 (CONFIRM) Study Results

	TECFIDERA, 240 mg BID (N=359)	Placebo (N=363)
Primary Endpoint		
Annualized relapse rate	0.224	0.401
Relative risk reduction (percentage)	44%	
Secondary Endpoints		
Proportion relapsing at 2 years	0.291	0.410
Relative risk reduction (percentage)	34%	
Proportion with disability progression	0.128	0.169
Relative risk reduction (percentage)	21%	
Mean number of new or newly enlarging T2 lesions over 2 years	5.1	17.4
Relative reduction (percentage)	71%	
Mean number of new T1 hypointense lesions over 2 years	3.0	7.0
Relative reduction (percentage)	57%	

DETAILED PHARMACOLOGY

Mechanism of Action

Preclinical studies indicate that dimethyl fumarate pharmacodynamic responses appear to be mediated, in part, through activation of the Nuclear factor (erythroid-derived 2)-like 2 (Nrf2) transcriptional pathway, which is the primary cellular defense system for responding to a variety of potentially toxic stimuli, including inflammatory and oxidative stress, through up-regulation of antioxidant response genes. In studies done *in vitro* and *in vivo* in animals DMF and/or MMF treatment reduced inflammatory responses in both peripheral and central cells, and central nervous system cells were protected against experimentally-induced toxic oxidative insults when treated with DMF. The mechanism by which TECFIDERA exerts therapeutic effects in multiple sclerosis is not known.

Pharmacodynamic Effects

Activation of the Nuclear factor (erythroid-derived 2)-like 2 (Nrf2) Pathway: The TECFIDERA mechanism of action appears to be mediated, at least in part, through activation of the Nrf2 anti-oxidant response pathway.

Effects on Immune System: In preclinical studies, TECFIDERA demonstrates anti-inflammatory and immunomodulatory properties. Dimethyl fumarate and MMF significantly reduce immune cell activation and subsequent release of pro-inflammatory cytokines in response to inflammatory stimuli. In addition, lymphocytes show down-regulation of pro-inflammatory cytokine profiles (T_H1, T_H17), and are biased towards anti-inflammatory production (T_H2). Dimethyl fumarate also demonstrates efficacy in models of inflammatory and neuroinflammatory injury, and also appears to promote improvement in blood brain barrier integrity.

Effects on Central Nervous System: Dimethyl fumarate and MMF significantly improved cell viability after oxidative challenge in primary cultures of astrocytes and neurons. In preclinical studies MMF was able to penetrate into the central nervous system. Acute neurotoxic injury models and genetic models of neurodegenerative disease (experimental autoimmune encephalitis) have demonstrated that dimethyl fumarate is effective in reducing neuronal and functional damage resulting from various types of experimental toxic stimuli and other forms of cellular stress inherent in animal models of neurodegenerative disease states.

Safety Pharmacology

Non-clinical safety pharmacology studies in mice and dogs indicate that dimethyl fumarate and MMF do not have any drug-related adverse effects on the CNS, respiratory and cardiovascular systems. DMF and MMF revealed no relevant interaction at hERG channels and did not alter cardiac conduction of canine Purkinje fibers or the ECG in a cardiovascular dog study. This is in agreement with the absence of any ECG effect in the chronic toxicity studies with DMF in dogs and monkeys.

Non-Clinical Pharmacokinetics

Pharmacokinetic studies of dimethyl fumarate and its primary active metabolite monomethyl fumarate (MMF) have been conducted in mice, rats, dogs and monkeys, as well as pregnant rats and rabbits. In all *in vivo* preclinical studies, except the dog regional absorption study, dimethyl fumarate was administered via the oral route. Regional absorption was determined in male dogs given a single dose of dimethyl fumarate directly to sites within the duodenum, jejunum, ileum and colon, and

demonstrated that absorption can occur throughout the intestine, but the majority occurred in the duodenum and jejunum. Dimethyl fumarate concentrations were below the LLOQ at all-time points in all animal species after oral administration, as dimethyl fumarate is rapidly pre-systemically hydrolyzed to MMF after oral administration and therefore PK analysis was only performed on MMF. Overall, the absorption, distribution, metabolism and excretion of dimethyl fumarate are similar across all species examined including humans.

The absorption of dimethyl fumarate was rapid, yielding T_{max} values between 10-30 min after oral dosing. The elimination was also rapid, characterized by terminal phase half-lives of less than 1 hour in both rats and dogs. The overall exposure (AUC and C_{max}) increased in all species with dose, generally in a dose proportional manner. Maximum tissue concentrations in rats, with the exception of the gastro-intestinal (GI) tract, were observed in organs of excretion, glandular tissues, and brain. Gender difference in pharmacokinetics has been detected in the rat only with the female exposure up to two times higher than the male. Plasma protein binding of MMF was low in rat, dog, monkey, and human plasma (unbound 55 to 100%) and binding was concentration independent.

Glucose is the predominant circulating metabolite in male and female rats, accounting for 50% of the plasma total extractable radioactivity. Other major metabolites, fumaric acid and citric acid combined, accounted for 33% of the circulating radioactivity. The total concentrations of fumaric acid after dimethyl fumarate administration in rats and dogs remained within the physiological limits at all measurement times. MMF accounted for less than 0.2% of the total circulating radioactivity $AUC_{(0-72h)}$ in rat plasma. There were no apparent gender related differences in the metabolic profiles. All of the metabolites identified in humans were found in the rat.

Total recovery of the administered radioactive dose was greater than 89% in both male and female rats. The primary route of elimination of dimethyl fumarate is exhalation of CO_2 followed by urine. The majority of dose was recovered in the expired air (~63%), as a result of dimethyl fumarate being converted to CO_2 as an end metabolite via the tricarboxylic acid (TCA) cycle. Cysteine and/or N-acetyl cysteine conjugates of mono- and di-methyl succinate were the major urinary metabolites in rat urine. Less than 0.2% of the dose was excreted in urine as unchanged dimethyl fumarate.

TOXICOLOGY

All nonclinical safety studies in rodents and non-rodents were conducted with a dimethyl fumarate suspension (in 0.8% hydroxypropyl methylcellulose) administered by oral gavage, except acute and chronic studies in the dog that were conducted with oral administration of the TECFIDERA (dimethyl fumarate) capsule.

Kidney changes were observed after repeated oral administration of dimethyl fumarate in mice, rats, dogs, and monkeys. Renal tubule epithelial regeneration, suggestive of tubule epithelial injury, was observed in all species. Exacerbation of age-related nephropathy and renal tubular hyperplasia were observed in mice and rats with chronic and life time dosing (2 year study) at all dose levels; hence there are no safety margins. In dogs, renal tubular dilatation and hypertrophy and hyperplasia of papillary urothelium at all dose levels, and tubular epithelial regeneration at higher dose levels indicate no safety margin was identified for renal toxicity. In monkeys, single cell necrosis and regeneration of tubular epithelial cells and, interstitial fibrosis with tubular atrophy were observed. The findings in

monkeys were observed after daily oral doses of dimethyl fumarate for 12 months at approximately 2 times the RHD for single cell necrosis and at 6 times the RHD for interstitial fibrosis, based on AUC. The relevance of these findings to human risk is not known.

Parathyroid hyperplasia and adenoma in the 2-year rat study were considered secondary to renal toxicity.

In the testes, degeneration of the seminiferous epithelium was seen in rats and dogs at the high dose in an 11-month study and interstitial (Leydig) cell hyperplasia was seen in rats at all dose levels in a male fertility study and with lifetime dosing (2-year study). Findings were observed at less than the RHD in rats, and 3 times the RHD in dogs (AUC basis). The relevance of these findings to humans is not known.

In the forestomach (nonglandular stomach) of mice and rats, squamous epithelial hyperplasia and hyperkeratosis, inflammation, squamous cell papilloma and carcinoma were observed in studies of at least 3 months duration. The forestomach of mice and rats does not have a human counterpart.

Findings in the liver in a 6-month study in rats were reported only in rats and not in mice, dogs or monkeys. Findings in the retina in the mouse carcinogenicity study were reported only in this study and not with other species.

Carcinogenesis: Carcinogenicity studies of dimethyl fumarate were conducted in mice and rats. In mice, dimethyl fumarate was administered at oral doses of 25, 75, 200, and 400 (dose reduced from 600) mg/kg/day for up to 2 years. The incidence of renal tubular adenoma (benign) and carcinoma was increased at 4 times the RHD on an AUC basis. Renal tumours were considered to be the result of the exacerbation of nephropathy caused by chronic renal toxicity. The relevance of these findings to human risk is unknown. The incidence of leiomyosarcoma, papilloma, and squamous cell carcinoma in the nonglandular stomach (forestomach) was increased at 4 times the RHD (AUC basis). The forestomach of mice does not have a human counterpart. Plasma MMF exposure (AUC) at the highest dose that was not associated with tumors in mouse (75 mg/kg/day) was similar to that in humans at the RHD of 480 mg/day.

In rats, dimethyl fumarate was administered at oral doses of 25, 50, 100 and 150 mg/kg/day for up to 2 years. In males, an increase in the incidence of benign interstitial cell (Leydig cell) adenoma of the testes was observed at 1.5 times the RHD based on relative AUC values. The incidence of squamous cell papilloma and carcinoma of the nonglandular stomach (forestomach) was increased below the RHD. The forestomach of rats does not have a human counterpart. Plasma MMF AUC at the lowest dose tested was lower than that in humans at the RHD.

Mutagenesis: Dimethyl fumarate (DMF) and monomethyl fumarate (MMF) were not mutagenic in the *in vitro* bacterial reverse mutation (Ames) assay. DMF and MMF were clastogenic in the *in vitro* chromosomal aberration assay in human peripheral blood lymphocytes in the absence of metabolic activation. DMF was not clastogenic in the *in vivo* micronucleus assay in the rat.

Fertility: Administration of dimethyl fumarate to male rats at daily oral doses of 75, 250, and 375 mg/kg prior to and during mating had no effects on male fertility up to the highest dose tested (9 times the RHD based on mg/m²). Administration of dimethyl fumarate to female rats at daily oral doses of

25, 100, 250 mg/kg/day prior to and during mating, and continuing to Day 7 gestation, caused disruption of the estrous cycle and increases in embryoletality at the highest dose tested. The highest dose not associated with adverse effects (100 mg/kg/day) is twice the RHD on a mg/m² basis. Testicular toxicity (germinal epithelial degeneration, atrophy, hypospermia, and/or hyperplasia) was observed at clinically relevant doses in mouse, rat, and dog in subchronic and chronic oral toxicity studies of DMF.

Teratogenicity: No malformations were observed at any dose of dimethyl fumarate in rats or rabbits. Administration of dimethyl fumarate at daily oral doses of 25, 100, and 250 mg/kg/day to pregnant rats during the period of organogenesis resulted in reductions in maternal body weight at 4 times the RHD on an AUC basis, and reductions in fetal weight, increased alterations and reduced ossification (metatarsals and hindlimb phalanges) at 11 times the RHD on an AUC basis. The effects on the fetus may have been secondary to maternal toxicity.

Administration of dimethyl fumarate at daily oral doses of 25, 75, and 150 mg/kg/day to pregnant rabbits during organogenesis had no effect on embryo-fetal development and resulted in reductions in maternal body weight at doses 7 times the RHD and increased abortion at 16 times the RHD on an AUC basis.

Administration of dimethyl fumarate at daily oral doses of 25, 100, and 250 mg/kg/day to rats during pregnancy and lactation resulted in lower body weights in the F1 offspring, and delays in sexual maturation in F1 males at 11 times the RHD on an AUC basis. There were no effects on fertility in the F1 offspring. The effects on the F1 offspring may have been secondary to maternal toxicity.

REFERENCES

1. Bruck W, Bitsch A, Kolenda H, et al. Inflammatory central nervous system demyelination: correlation of magnetic resonance imaging findings with lesion pathology. *Ann Neurol*. 1997; 42(5): 783-93.
2. Fox RJ, Miller DH, Phillips T, et al. Placebo-controlled phase 3 study of oral BG-12 or glatiramer in multiple sclerosis. *N Engl J Med*. 2012; 367: 1087-97.
3. Gold R, Kappos L, Arnold DL, et al. Placebo-controlled phase 3 study of oral BG-12 for relapsing multiple sclerosis. *N Engl J Med*. 2012; 367: 1098-107.
4. Ghoreschi, K., J. Bruck, Kellerer C, et al. Fumarates improve psoriasis and multiple sclerosis by inducing type II dendritic cells. *J Exp Med*. 2011; 208(11): 2291-303.
5. Kappos L, Gold R, Miller DH, et al. Efficacy and safety of oral fumarate in patients with relapsing-remitting multiple sclerosis: a multicentre, randomised, double-blind, placebo-controlled phase IIb study. *Lancet*. 2008; 372(9648): 1463-72.
6. Kappos L, Gold R, Miller DH, et al. Effect of BG-12 on contrast-enhancing lesions in patients with relapsing-remitting multiple sclerosis: subgroup analyses from the phase 2b study. *Mult Scler*. 2012; 18(3): 314-21.
7. Kobayashi, M., L. Li, et al. The antioxidant defense system Keap1-Nrf2 comprises a multiple sensing mechanism for responding to a wide range of chemical compounds. *Mol Cell Biol* 2009; 29(2): 493-502.
8. Linker RA, Lee DH, Ryan S, et al. Fumaric acid esters exert neuroprotective effects in neuroinflammation via activation of the Nrf2 antioxidant pathway. *Brain*. 2011; 134(Pt 3): 678-92.
9. Wilms, H., J. Sievers, et al. Dimethyl fumarate inhibits microglial and astrocytic inflammation by suppressing the synthesis of nitric oxide, IL-1beta, TNF-alpha and IL-6 in an *in-vitro* model of brain inflammation. *J Neuroinflammation*. 2010; 7: 30.
10. Zhao J, Moore AN, Redell JB, et al. Enhancing expression of Nrf2-driven genes protects the blood brain barrier after brain injury. *J Neurosci*. 2007; 27(38): 10240-8.

PART III: CONSUMER INFORMATION**TECFIDERA®
Dimethyl fumarate**

This leaflet is part III of a three-part "Product Monograph" published when TECFIDERA was approved for sale in Canada and is designed specifically for Consumers. This leaflet is a summary and will not tell you everything about TECFIDERA. Contact your doctor or pharmacist if you have any questions about the drug.

ABOUT THIS MEDICATION**What the medication is used for:**

TECFIDERA is a prescription medication to treat relapsing remitting multiple sclerosis (MS). TECFIDERA does not cure MS, but helps to reduce the number of flare-ups (relapses) that occur and slow the build-up of physical problems due to MS (disability progression).

What it does:

TECFIDERA may work by changing the way the body's immune system works, to help keep it from further damaging your brain and spinal cord.

When it should not be used:

Do not take TECFIDERA if you:
Have an allergy or are sensitive to dimethyl fumarate or any ingredients in this medicine.

TECFIDERA should not be used in children and adolescents under 18 years, because it has not been studied in MS patients younger than 18 years of age.

What the medicinal ingredient is:

Dimethyl fumarate.

What the nonmedicinal ingredients are:

Colloidal silicon dioxide, croscarmellose sodium, magnesium stearate, methacrylic acid copolymer (type A), methacrylic acid copolymer dispersion, microcrystalline cellulose, polysorbate 80, silicified microcrystalline cellulose, simethicone, sodium lauryl sulfate, talc, and triethyl citrate.

The capsule shell contains black iron oxide, FD&C Blue 1, gelatin, titanium dioxide, and yellow iron oxide.

What dosage forms it comes in:

Delayed-release capsules: 120 mg and 240 mg

WARNINGS AND PRECAUTIONS**BEFORE you use TECFIDERA talk to your doctor or pharmacist if:**

- You have or have had low white blood cell counts (low lymphocytes). Low lymphocyte counts may be caused by another illness that affects the immune system (for example, immunodeficiency syndrome), bone marrow transplantation,

- or other treatments that can suppress the immune system.
- You have an infection.
- You have Herpes Zoster Infections (Shingles)
- You have liver or kidney disease.
- You have a disease of the stomach or bowel.
- You are pregnant or planning to become pregnant.
- You are breast-feeding.

You should not receive certain types of vaccines (called "live attenuated vaccines") during treatment with TECFIDERA. Check with your doctor before receiving any vaccination during treatment or after stopping TECFIDERA.

INTERACTIONS WITH THIS MEDICATION

You should tell your doctor(s) if you are taking any other prescription or non-prescription medicines. This includes any vitamin or mineral supplements, or herbal products.

- Fumaric acid.** Do not use TECFIDERA with other types of fumaric acid. Ask your doctor or pharmacist if you are not sure what other products may contain fumaric acids.
- Medicines that affect the immune system** including some commonly used cancer treatments and other medicines used to treat MS, such as, natalizumab, fingolimod, or mitoxantrone. TECFIDERA should not be started while you are on other MS medications. If you stop taking one of these medicines to switch to TECFIDERA you may be required to wait before starting TECFIDERA. The amount of time you may need to wait will vary, depending on the treatment. Your doctor will know how long you may need to wait.
- Medicines that can affect the kidneys**, such as antibiotics from the aminoglycoside class, non-steroidal anti-inflammatory drugs (NSAIDs), diuretics, or lithium. TECFIDERA has not been studied in patients who take these drugs regularly.
- Vaccines.** During treatment with TECFIDERA, administration of vaccines containing live virus is not recommended.

PROPER USE OF THIS MEDICATION

Always follow your doctor's instructions for taking TECFIDERA. You should check with your doctor or pharmacist if you are not sure.

Swallow whole. Do not divide, crush, dissolve, suck, or chew the capsule.

TECFIDERA can be taken with or without food.

TECFIDERA capsules are packaged in a folding blister card inside a carton. Remove the capsules from the blister by pushing them through the foil.

Your doctor may reduce your dose if you have certain side effects.

Do not reduce your dose unless your doctor tells you to

Usual adult dose:

Starting dose: one 120 mg capsule twice a day (one in the morning and one in the evening).

Starting total daily dose: 240 mg a day.

Take this starting dose for the first 7 days, and then take the regular dose.

Regular dose: one 240 mg capsule twice a day (one in the morning and one in the evening).

Regular total daily dose: 480 mg a day.

Overdose:

If you have taken more TECFIDERA than your doctor has recommended, contact a regional Poison Control Centre immediately and a health care practitioner, or go the nearest hospital emergency department even if there are no symptoms. Take the medication package with you when you go to the hospital.

Missed Dose:

If you forget or miss a dose, do not double your next dose.

You may take the missed dose if you leave at least 4 hours between the morning and evening doses, otherwise wait and take your next dose as planned.

SIDE EFFECTS AND WHAT TO DO ABOUT THEM

Side effects may include:

Flushing and stomach upset. People are more likely to have these side effects when they first start taking TECFIDERA (mostly during the first month). Most people have mild to moderate symptoms and they tend to go away over time.

If you become flushed **and** get swelling of the face, lips, mouth or tongue, wheezing, difficulty breathing or shortness of breath, **stop taking TECFIDERA and seek emergency medical assistance.**

Signs of stomach upset may include:

- Diarrhea
- Nausea (feeling like you are going to be sick)
- Stomach pain or stomach cramps
- Vomiting (throwing up)
- Indigestion

Talk to your doctor about how to manage these side effects. Your doctor may reduce your dose. Do not reduce your dose unless your doctor tells you to.

Taking TECFIDERA with food may help manage these side effects. Your doctor may recommend taking an over-the-counter pain and fever reducer, such as aspirin, for a few days to manage signs of flushing.

TECFIDERA can cause abnormal blood and urine test results,

including decreases in your white blood cell count. Your doctor will decide when to perform blood and urine tests and will interpret the results.

SERIOUS SIDE EFFECTS, HOW OFTEN THEY HAPPEN AND WHAT TO DO ABOUT THEM

Symptom / effect		Talk with your doctor or pharmacist		Stop taking drug and seek emergency medical assistance
		Only if severe	In all cases	
Common	Flushing (symptoms of severe flushing may include general swelling, rash, itchiness)	✓		
	Gastrointestinal (GI) events (symptoms include diarrhea, nausea, stomach pain, vomiting, indigestion)	✓		
	Low levels of white blood cells (lymphocytes) (symptoms may include serious infections, e.g. pneumonia, or being more prone to infections)		✓	
	Proteins (albumin) in urine (symptoms may include swelling of the face or legs)		✓	
	Increased levels of liver enzymes (ALT, AST) in the blood (symptoms may include loss of appetite, fatigue, yellowing of the skin or eyes, or dark urine)		✓	
Un-common	Allergic reaction (symptoms include rash, itching, difficulty breathing, swelling of the face, lips, tongue or throat)			✓

SERIOUS SIDE EFFECTS, HOW OFTEN THEY HAPPEN AND WHAT TO DO ABOUT THEM

Symptom / effect		Talk with your doctor or pharmacist		Stop taking drug and seek emergency medical assistance
		Only if severe	In all cases	
Rare	Progressive multifocal leukoencephalopathy (PML), a rare brain infection. (symptoms may include: progressive weakness on one side of the body, clumsiness of limbs, disturbance of vision, changes in thinking, memory and orientation, confusion, personality changes)			✓
Not Known	Herpes zoster (shingles) (symptoms may include blisters, burning, itching or pain of the skin, typically on one side of the upper body or the face, and other symptoms like fever, weakness and numbness);		✓	

This is not a complete list of side effects. For any unexpected effects while taking TECFIDERA, contact your doctor or pharmacist.

HOW TO STORE IT

Store TECFIDERA at room temperature (between 15 to 30°C). Protect TECFIDERA from light. Store the capsules in their original packaging. Do not take your medicine after the expiry date shown on the carton. Keep out of reach and sight of children.

Medicines should not be disposed of in waste water or household garbage. Ask your pharmacist how to dispose of medicines you no longer need.

REPORTING SUSPECTED SIDE EFFECTS

You can report any suspected adverse reactions associated with the use of health products to the Canada Vigilance Program by one of the following 3 ways:

- Report online at www.healthcanada.gc.ca/medeffect
- Call toll-free at 1-866-234-2345
- Complete a Canada Vigilance Reporting Form and:
 - Fax toll-free to 1-866-678-6789, or
 - Mail to: Canada Vigilance Program
Health Canada
Postal Locator 0701E
Ottawa, Ontario
K1A 0K9

Postage paid labels, Canada Vigilance Reporting Form and the adverse reaction reporting guidelines are available on the MedEffect™ Canada Web site at www.healthcanada.gc.ca/medeffect.

NOTE: Should you require information related to the management of side effects, contact your health professional. The Canada Vigilance Program does not provide medical advice.

MORE INFORMATION

This document plus the full product monograph, prepared for health professionals can be obtained by contacting Biogen Canada Inc., at: 1-855-MSONE-00 (1-855-676-6300)

This leaflet was prepared by Biogen Canada Inc.

Last revised: November 28, 2019

HIGHLIGHTS OF PRESCRIBING INFORMATION

These highlights do not include all the information needed to use TECFIDERA safely and effectively. See full prescribing information for TECFIDERA.

TECFIDERA® (dimethyl fumarate) delayed-release capsules, for oral use
Initial U.S. Approval: 2013

RECENT MAJOR CHANGES

Indications and Usage (1)	7/2019
Warnings and Precautions, PML (5.2)	12/2019
Warnings and Precautions, Herpes Zoster and Other Serious Opportunistic Infections (5.3)	12/2019

INDICATIONS AND USAGE

TECFIDERA is indicated for the treatment of relapsing forms of multiple sclerosis (MS), to include clinically isolated syndrome, relapsing-remitting disease, and active secondary progressive disease, in adults (1)

DOSAGE AND ADMINISTRATION

- Starting dose: 120 mg twice a day, orally, for 7 days (2.1)
- Maintenance dose after 7 days: 240 mg twice a day, orally (2.1)
- Swallow TECFIDERA capsules whole and intact. Do not crush, chew, or sprinkle capsule contents on food (2.1)
- Take TECFIDERA with or without food (2.1)

DOSAGE FORMS AND STRENGTHS

Delayed-release capsules: 120 mg and 240 mg (3)

CONTRAINDICATIONS

Known hypersensitivity to dimethyl fumarate or any of the excipients of TECFIDERA. (4)

WARNINGS AND PRECAUTIONS

- Anaphylaxis and angioedema: Discontinue and do not restart TECFIDERA if these occur. (5.1)
- Progressive multifocal leukoencephalopathy (PML): Withhold TECFIDERA at the first sign or symptom suggestive of PML. (5.2)
- Herpes zoster and other serious opportunistic infections: Consider withholding TECFIDERA in cases of serious infection until the infection has resolved. (5.3)
- Lymphopenia: Obtain a CBC including lymphocyte count before initiating TECFIDERA, after 6 months, and every 6 to 12 months thereafter. Consider interruption of TECFIDERA if lymphocyte counts $<0.5 \times 10^9/L$ persist for more than six months. (5.4)
- Liver injury: Obtain serum aminotransferase, alkaline phosphatase, and total bilirubin levels before initiating TECFIDERA and during treatment, as clinically indicated. Discontinue TECFIDERA if clinically significant liver injury induced by TECFIDERA is suspected. (5.5)

ADVERSE REACTIONS

Most common adverse reactions (incidence $\geq 10\%$ and $\geq 2\%$ placebo) were flushing, abdominal pain, diarrhea, and nausea. (6.1)

To report SUSPECTED ADVERSE REACTIONS, contact Biogen at 1-800-456-2255 or FDA at 1-800-FDA-1088 or www.fda.gov/medwatch.

USE IN SPECIFIC POPULATIONS

Pregnancy: Based on animal data, may cause fetal harm. (8.1)

See 17 for PATIENT COUNSELING INFORMATION and FDA-approved patient labeling

Revised: 2/2020

FULL PRESCRIBING INFORMATION: CONTENTS*

1 INDICATIONS AND USAGE

2 DOSAGE AND ADMINISTRATION

2.1 Dosing Information

2.2 Blood Tests Prior to Initiation of Therapy

3 DOSAGE FORMS AND STRENGTHS

4 CONTRAINDICATIONS

5 WARNINGS AND PRECAUTIONS

5.1 Anaphylaxis and Angioedema

5.2 Progressive Multifocal Leukoencephalopathy

5.3 Herpes Zoster and Other Serious Opportunistic Infections

5.4 Lymphopenia

5.5 Liver Injury

5.6 Flushing

6 ADVERSE REACTIONS

6.1 Clinical Trials Experience

6.2 Post Marketing Experience

8 USE IN SPECIFIC POPULATIONS

8.1 Pregnancy

8.2 Lactation

8.4 Pediatric Use

8.5 Geriatric Use

10 OVERDOSE

11 DESCRIPTION

12 CLINICAL PHARMACOLOGY

12.1 Mechanism of Action

12.2 Pharmacodynamics

12.3 Pharmacokinetics

13 NONCLINICAL TOXICOLOGY

13.1 Carcinogenesis, Mutagenesis, Impairment of Fertility

13.2 Animal Toxicology and/or Pharmacology

14 CLINICAL STUDIES

16 HOW SUPPLIED/STORAGE AND HANDLING

17 PATIENT COUNSELING INFORMATION

*Sections or subsections omitted from the full prescribing information are not listed.

FULL PRESCRIBING INFORMATION

1 INDICATIONS AND USAGE

TECFIDERA is indicated for the treatment of relapsing forms of multiple sclerosis (MS), to include clinically isolated syndrome, relapsing-remitting disease, and active secondary progressive disease, in adults.

2 DOSAGE AND ADMINISTRATION

2.1 Dosing Information

The starting dose for TECFIDERA is 120 mg twice a day orally. After 7 days, the dose should be increased to the maintenance dose of 240 mg twice a day orally. Temporary dose reductions to 120 mg twice a day may be considered for individuals who do not tolerate the maintenance dose. Within 4 weeks, the recommended dose of 240 mg twice a day should be resumed. Discontinuation of TECFIDERA should be considered for patients unable to tolerate return to the maintenance dose. The incidence of flushing may be reduced by administration of TECFIDERA with food. Alternatively, administration of non-enteric coated aspirin (up to a dose of 325 mg) 30 minutes prior to TECFIDERA dosing may reduce the incidence or severity of flushing [*see Clinical Pharmacology (12.3)*].

TECFIDERA should be swallowed whole and intact. TECFIDERA should not be crushed or chewed and the capsule contents should not be sprinkled on food. TECFIDERA can be taken with or without food.

2.2 Blood Tests Prior to Initiation of Therapy

Obtain a complete blood cell count (CBC) including lymphocyte count before initiation of therapy [*see Warnings and Precautions (5.4)*].

Obtain serum aminotransferase, alkaline phosphatase, and total bilirubin levels prior to treatment with TECFIDERA [*see Warnings and Precautions (5.5)*].

3 DOSAGE FORMS AND STRENGTHS

TECFIDERA is available as hard gelatin delayed-release capsules containing 120 mg or 240 mg of dimethyl fumarate. The 120 mg capsules have a green cap and white body, printed with “BG-12 120 mg” in black ink on the body. The 240 mg capsules have a green cap and a green body, printed with “BG-12 240 mg” in black ink on the body.

4 CONTRAINDICATIONS

TECFIDERA is contraindicated in patients with known hypersensitivity to dimethyl fumarate or to any of the excipients of TECFIDERA. Reactions have included anaphylaxis and angioedema [*see Warnings and Precautions (5.1)*].

5 WARNINGS AND PRECAUTIONS

5.1 Anaphylaxis and Angioedema

TECFIDERA can cause anaphylaxis and angioedema after the first dose or at any time during treatment. Signs and symptoms have included difficulty breathing, urticaria, and swelling of the throat and tongue. Patients should be instructed to discontinue TECFIDERA and seek immediate medical care should they experience signs and symptoms of anaphylaxis or angioedema.

5.2 Progressive Multifocal Leukoencephalopathy

Progressive multifocal leukoencephalopathy (PML) has occurred in patients with MS treated with TECFIDERA. PML is an opportunistic viral infection of the brain caused by the JC virus (JCV) that typically only occurs in patients who are immunocompromised, and that usually leads to death or severe disability. A fatal case of PML occurred in a patient who received TECFIDERA for 4 years while enrolled in a clinical trial. During the clinical trial, the patient experienced prolonged lymphopenia (lymphocyte counts predominantly $<0.5 \times 10^9/L$ for 3.5 years) while taking TECFIDERA [see Warnings and Precautions (5.4)]. The patient had no other identified systemic medical conditions resulting in compromised immune system function and had not previously been treated with natalizumab, which has a known association with PML. The patient was also not taking any immunosuppressive or immunomodulatory medications concomitantly.

PML has also occurred in the postmarketing setting in the presence of lymphopenia ($<0.9 \times 10^9/L$). While the role of lymphopenia in these cases is uncertain, the PML cases have occurred predominantly in patients with lymphocyte counts $<0.8 \times 10^9/L$ persisting for more than 6 months.

At the first sign or symptom suggestive of PML, withhold TECFIDERA and perform an appropriate diagnostic evaluation. Typical symptoms associated with PML are diverse, progress over days to weeks, and include progressive weakness on one side of the body or clumsiness of limbs, disturbance of vision, and changes in thinking, memory, and orientation leading to confusion and personality changes.

MRI findings may be apparent before clinical signs or symptoms. Cases of PML, diagnosed based on MRI findings and the detection of JCV DNA in the cerebrospinal fluid in the absence of clinical signs or symptoms specific to PML, have been reported in patients treated with other MS medications associated with PML. Many of these patients subsequently became symptomatic with PML. Therefore, monitoring with MRI for signs that may be consistent with PML may be useful, and any suspicious findings should lead to further investigation to allow for an early diagnosis of PML, if present. Lower PML-related mortality and morbidity have been reported following discontinuation of another MS medication associated with PML in patients with PML who were initially asymptomatic compared to patients with PML who had characteristic clinical signs and symptoms at diagnosis. It is not known whether these differences are due to early detection and discontinuation of MS treatment or due to differences in disease in these patients.

5.3 Herpes Zoster and Other Serious Opportunistic Infections

Serious cases of herpes zoster have occurred with TECFIDERA, including disseminated herpes zoster, herpes zoster ophthalmicus, herpes zoster meningoencephalitis, and herpes zoster meningomyelitis. These events may occur at any time during treatment. Monitor patients on TECFIDERA for signs and symptoms of herpes zoster. If herpes zoster occurs, appropriate treatment for herpes zoster should be administered.

Other serious opportunistic infections have occurred with TECFIDERA, including cases of serious viral (herpes simplex virus, West Nile virus, cytomegalovirus), fungal (Candida and Aspergillus), and bacterial (Nocardia, Listeria monocytogenes, Mycobacterium tuberculosis) infections. These infections have been reported in patients with reduced absolute lymphocyte counts (ALC) as well as in patients with normal ALC. These infections have affected the brain, meninges, spinal cord, gastrointestinal tract, lungs, skin, eye, and ear. Patients with symptoms and signs consistent with any of these infections should undergo prompt diagnostic evaluation and receive appropriate treatment.

Consider withholding TECFIDERA treatment in patients with herpes zoster or other serious infections until the infection has resolved [*see Adverse Reactions (6.2)*].

5.4 Lymphopenia

TECFIDERA may decrease lymphocyte counts. In the MS placebo controlled trials, mean lymphocyte counts decreased by approximately 30% during the first year of treatment with TECFIDERA and then remained stable. Four weeks after stopping TECFIDERA, mean lymphocyte counts increased but did not return to baseline. Six percent (6%) of TECFIDERA patients and <1% of placebo patients experienced lymphocyte counts $<0.5 \times 10^9/L$ (lower limit of normal $0.91 \times 10^9/L$). The incidence of infections (60% vs 58%) and serious infections (2% vs 2%) was similar in patients treated with TECFIDERA or placebo, respectively. There was no increased incidence of serious infections observed in patients with lymphocyte counts $<0.8 \times 10^9/L$ or $\leq 0.5 \times 10^9/L$ in controlled trials, although one patient in an extension study developed PML in the setting of prolonged lymphopenia (lymphocyte counts predominantly $<0.5 \times 10^9/L$ for 3.5 years) [*see Warnings and Precautions (5.2)*].

In controlled and uncontrolled clinical trials, 2% of patients experienced lymphocyte counts $<0.5 \times 10^9/L$ for at least six months, and in this group the majority of lymphocyte counts remained $<0.5 \times 10^9/L$ with continued therapy. TECFIDERA has not been studied in patients with pre-existing low lymphocyte counts.

Obtain a CBC, including lymphocyte count, before initiating treatment with TECFIDERA, 6 months after starting treatment, and then every 6 to 12 months thereafter, and as clinically indicated. Consider interruption of TECFIDERA in patients with lymphocyte counts less than $0.5 \times 10^9/L$ persisting for more than six months. Given the potential for delayed recovery of lymphocyte counts, continue to obtain lymphocyte counts until their recovery if TECFIDERA is discontinued or interrupted due to lymphopenia. Consider withholding treatment from patients with serious infections until resolution. Decisions about whether or not to restart TECFIDERA should be individualized based on clinical circumstances.

5.5 Liver Injury

Clinically significant cases of liver injury have been reported in patients treated with TECFIDERA in the postmarketing setting. The onset has ranged from a few days to several months after initiation of treatment with TECFIDERA. Signs and symptoms of liver injury, including elevation of serum aminotransferases to greater than 5-fold the upper limit of normal and elevation of total bilirubin to greater than 2-fold the upper limit of normal have been observed. These abnormalities resolved upon treatment discontinuation. Some cases required hospitalization. None of the reported cases resulted in liver failure, liver transplant, or death. However, the combination of new serum aminotransferase elevations with increased levels of bilirubin caused by drug-induced hepatocellular injury is an important predictor of serious liver injury that may lead to acute liver failure, liver transplant, or death in some patients.

Elevations of hepatic transaminases (most no greater than 3 times the upper limit of normal) were observed during controlled trials [*see Adverse Reactions (6.1)*].

Obtain serum aminotransferase, alkaline phosphatase (ALP), and total bilirubin levels prior to treatment with TECFIDERA and during treatment, as clinically indicated. Discontinue TECFIDERA if clinically significant liver injury induced by TECFIDERA is suspected.

5.6 Flushing

TECFIDERA may cause flushing (e.g., warmth, redness, itching, and/or burning sensation). In clinical trials, 40% of TECFIDERA treated patients experienced flushing. Flushing symptoms generally began soon after initiating TECFIDERA and usually improved or resolved over time. In the majority of patients who experienced flushing, it was mild or moderate in severity. Three percent (3%) of patients discontinued TECFIDERA for flushing and <1% had serious flushing symptoms that were not life-threatening but led to hospitalization. Administration of TECFIDERA with food may reduce the incidence of flushing. Alternatively, administration of non-enteric coated aspirin (up to a dose of 325 mg) 30 minutes prior to TECFIDERA dosing may reduce the incidence or severity of flushing [*see Dosing and Administration (2.1)* and *Clinical Pharmacology (12.3)*].

6 ADVERSE REACTIONS

The following important adverse reactions are described elsewhere in labeling:

- Anaphylaxis and Angioedema [*see Warnings and Precautions (5.1)*].
- Progressive multifocal leukoencephalopathy [*see Warnings and Precautions (5.2)*].
- Herpes Zoster and Other Serious Opportunistic Infections [*see Warnings and Precautions (5.3)*].
- Lymphopenia [*see Warnings and Precautions (5.4)*].
- Liver Injury [*see Warnings and Precautions (5.5)*].
- Flushing [*see Warnings and Precautions (5.6)*].

6.1 Clinical Trials Experience

Because clinical trials are conducted under widely varying conditions, adverse reaction rates observed in clinical trials of a drug cannot be directly compared to rates in the clinical trials of another drug and may not reflect the rates observed in clinical practice.

The most common adverse reactions (incidence $\geq 10\%$ and $\geq 2\%$ more than placebo) for TECFIDERA were flushing, abdominal pain, diarrhea, and nausea.

Adverse Reactions in Placebo-Controlled Trials

In the two well-controlled studies demonstrating effectiveness, 1529 patients received TECFIDERA with an overall exposure of 2244 person-years [see *Clinical Studies (14)*].

The adverse reactions presented in the table below are based on safety information from 769 patients treated with TECFIDERA 240 mg twice a day and 771 placebo-treated patients.

Table 1: Adverse Reactions in Study 1 and 2 reported for TECFIDERA 240 mg BID at $\geq 2\%$ higher incidence than placebo

	TECFIDERA N=769 %	Placebo N=771 %
Flushing	40	6
Abdominal pain	18	10
Diarrhea	14	11
Nausea	12	9
Vomiting	9	5
Pruritus	8	4
Rash	8	3
Albumin urine present	6	4
Erythema	5	1
Dyspepsia	5	3
Aspartate aminotransferase increased	4	2
Lymphopenia	2	<1

Gastrointestinal

TECFIDERA caused GI events (e.g., nausea, vomiting, diarrhea, abdominal pain, and dyspepsia). The incidence of GI events was higher early in the course of treatment (primarily in month 1) and usually decreased over time in patients treated with TECFIDERA compared with placebo. Four percent (4%) of patients treated with TECFIDERA and less than 1% of placebo patients discontinued due to gastrointestinal events. The incidence of serious GI events was 1% in patients treated with TECFIDERA.

Hepatic Transaminases

An increased incidence of elevations of hepatic transaminases in patients treated with TECFIDERA was seen primarily during the first six months of treatment, and most patients with elevations had levels < 3 times the upper limit of normal (ULN) during controlled trials. Elevations of alanine aminotransferase and aspartate aminotransferase to ≥ 3 times the ULN occurred in a small number of patients treated with both TECFIDERA and placebo and were balanced between groups. There were no elevations in transaminases ≥ 3 times the ULN with concomitant elevations in total bilirubin > 2 times the ULN. Discontinuations due to elevated

hepatic transaminases were < 1% and were similar in patients treated with TECFIDERA or placebo.

Eosinophilia

A transient increase in mean eosinophil counts was seen during the first 2 months of therapy.

Adverse Reactions in Placebo-Controlled and Uncontrolled Studies

In placebo-controlled and uncontrolled clinical studies, a total of 2513 patients have received TECFIDERA and been followed for periods up to 4 years with an overall exposure of 4603 person-years. Approximately 1162 patients have received more than 2 years of treatment with TECFIDERA. The adverse reaction profile of TECFIDERA in the uncontrolled clinical studies was consistent with the experience in the placebo-controlled clinical trials.

6.2 Postmarketing Experience

The following adverse reaction has been identified during post-approval use of TECFIDERA. Because these reactions are reported voluntarily from a population of uncertain size, it is not always possible to reliably estimate their frequency or establish a causal relationship to drug exposure.

Liver function abnormalities (elevations in transaminases ≥ 3 times ULN with concomitant elevations in total bilirubin > 2 times ULN) have been reported following TECFIDERA administration in postmarketing experience [*See Warnings and Precautions (5.5)*].

Herpes zoster infection and other serious opportunistic infections have been reported with TECFIDERA administration in postmarketing experience [*See Warnings and Precautions (5.3)*].

8 USE IN SPECIFIC POPULATIONS

8.1 Pregnancy

Pregnancy Exposure Registry

There is a pregnancy exposure registry that monitors pregnancy outcomes in women exposed to TECFIDERA during pregnancy. Encourage patients to enroll by calling 1-866-810-1462 or visiting www.tecfiderapregnancyregistry.com.

Risk Summary

There are no adequate data on the developmental risk associated with the use of TECFIDERA in pregnant women. In animals, adverse effects on offspring survival, growth, sexual maturation, and neurobehavioral function were observed when dimethyl fumarate (DMF) was administered during pregnancy and lactation at clinically relevant doses [*see Data*].

In the U.S. general population, the estimated background risk of major birth defects and miscarriage in clinically recognized pregnancies is 2-4% and 15-20%, respectively. The background risk of major birth defects and miscarriage for the indicated population is unknown.

Data

Animal Data

In rats administered DMF orally (25, 100, 250 mg/kg/day) throughout organogenesis, embryofetal toxicity (reduced fetal body weight and delayed ossification) were observed at the highest dose tested. This dose also produced evidence of maternal toxicity (reduced body weight). Plasma exposure (AUC) for monomethyl fumarate (MMF), the major circulating metabolite, at the no-effect dose is approximately three times that in humans at the recommended human dose (RHD) of 480 mg/day. In rabbits administered DMF orally (25, 75, and 150 mg/kg/day) throughout organogenesis, embryoletality and decreased maternal body weight were observed at the highest dose tested. The plasma AUC for MMF at the no-effect dose is approximately 5 times that in humans at the RHD.

Oral administration of DMF (25, 100, and 250 mg/kg/day) to rats throughout organogenesis and lactation resulted in increased lethality, persistent reductions in body weight, delayed sexual maturation (male and female pups), and reduced testicular weight at the highest dose tested. Neurobehavioral impairment was observed at all doses. A no-effect dose for developmental toxicity was not identified. The lowest dose tested was associated with plasma AUC for MMF lower than that in humans at the RHD.

8.2 Lactation

Risk Summary

There are no data on the presence of DMF or MMF in human milk. The effects on the breastfed infant and on milk production are unknown.

The developmental and health benefits of breastfeeding should be considered along with the mother's clinical need for TECFIDERA and any potential adverse effects on the breastfed infant from the drug or from the underlying maternal condition.

8.4 Pediatric Use

Safety and effectiveness in pediatric patients have not been established.

8.5 Geriatric Use

Clinical studies of TECFIDERA did not include sufficient numbers of patients aged 65 and over to determine whether they respond differently from younger patients.

10 OVERDOSE

Cases of overdose with TECFIDERA have been reported. The symptoms described in these cases were consistent with the known adverse event profile of TECFIDERA.

There are no known therapeutic interventions to enhance elimination of TECFIDERA nor is there a known antidote. In the event of overdose, initiate symptomatic supportive treatment as clinically indicated.

11 DESCRIPTION

TECFIDERA contains dimethyl fumarate which is also known by its chemical name, dimethyl (E) butenedioate, (C₆H₈O₄). It has the following structure:

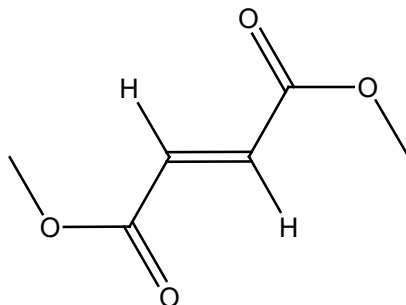

Dimethyl fumarate is a white to off-white powder that is highly soluble in water with a molecular mass of 144.13.

TECFIDERA is provided as hard gelatin delayed-release capsules for oral administration, containing 120 mg or 240 mg of dimethyl fumarate consisting of the following inactive ingredients: microcrystalline cellulose, silicified microcrystalline cellulose, croscarmellose sodium, talc, silica colloidal silicon dioxide, magnesium stearate, triethyl citrate, methacrylic acid copolymer - Type A, methacrylic acid copolymer dispersion, simethicone (30% emulsion), sodium lauryl sulphate, and polysorbate 80. The capsule shell, printed with black ink, contains the following inactive ingredients: gelatin, titanium dioxide, FD&C blue 1; brilliant blue FCF, yellow iron oxide and black iron oxide.

12 CLINICAL PHARMACOLOGY

12.1 Mechanism of Action

The mechanism by which dimethyl fumarate (DMF) exerts its therapeutic effect in multiple sclerosis is unknown. DMF and the metabolite, monomethyl fumarate (MMF), have been shown to activate the Nuclear factor (erythroid-derived 2)-like 2 (Nrf2) pathway *in vitro* and *in vivo* in animals and humans. The Nrf2 pathway is involved in the cellular response to oxidative stress. MMF has been identified as a nicotinic acid receptor agonist *in vitro*.

12.2 Pharmacodynamics

Potential to prolong the QT interval

In a placebo controlled thorough QT study performed in healthy subjects, there was no evidence that dimethyl fumarate caused QT interval prolongation of clinical significance (i.e., the upper bound of the 90% confidence interval for the largest placebo-adjusted, baseline-corrected QTc was below 10 ms).

12.3 Pharmacokinetics

After oral administration of TECFIDERA, dimethyl fumarate undergoes rapid presystemic hydrolysis by esterases and is converted to its active metabolite, monomethyl fumarate (MMF). Dimethyl fumarate is not quantifiable in plasma following oral administration of TECFIDERA. Therefore all pharmacokinetic analyses related to TECFIDERA were performed with plasma MMF concentrations. Pharmacokinetic data were obtained in subjects with multiple sclerosis and healthy volunteers.

Absorption

The median T_{max} of MMF is 2-2.5 hours. The peak plasma concentration (C_{max}) and overall exposure (AUC) increased approximately dose proportionally in the dose range studied (120 mg to 360 mg). Following administration of TECFIDERA 240 mg twice a day with food, the mean C_{max} of MMF was 1.87 mg/L and AUC was 8.21 mg.hr/L in MS patients.

A high-fat, high-calorie meal did not affect the AUC of MMF but decreased its C_{max} by 40%. The T_{max} was delayed from 2.0 hours to 5.5 hours. In this study, the incidence of flushing was reduced by approximately 25% in the fed state.

Distribution

The apparent volume of distribution of MMF varies between 53 and 73 L in healthy subjects. Human plasma protein binding of MMF is 27-45% and independent of concentration.

Metabolism

In humans, dimethyl fumarate is extensively metabolized by esterases, which are ubiquitous in the gastrointestinal tract, blood, and tissues, before it reaches the systemic circulation. Further metabolism of MMF occurs through the tricarboxylic acid (TCA) cycle, with no involvement of the cytochrome P450 (CYP) system. MMF, fumaric and citric acid, and glucose are the major metabolites in plasma.

Elimination

Exhalation of CO_2 is the primary route of elimination, accounting for approximately 60% of the TECFIDERA dose. Renal and fecal elimination are minor routes of elimination, accounting for 16% and 1% of the dose respectively. Trace amounts of unchanged MMF were present in urine.

The terminal half-life of MMF is approximately 1 hour and no circulating MMF is present at 24 hours in the majority of individuals. Accumulation of MMF does not occur with multiple doses of TECFIDERA.

Specific Populations

Body weight, gender, and age do not require dosage adjustment.

No studies have been conducted in subjects with hepatic or renal impairment. However, neither condition would be expected to affect exposure to MMF and therefore no dosage adjustment is necessary.

Drug Interaction Studies

No potential drug interactions with dimethyl fumarate or MMF were identified in *in vitro* CYP inhibition and induction studies, or in P-glycoprotein studies. Single doses of interferon beta-1a

or glatiramer acetate did not alter the pharmacokinetics of MMF. Aspirin, when administered approximately 30 minutes before TECFIDERA, did not alter the pharmacokinetics of MMF.

Oral Contraceptives

The coadministration of dimethyl fumarate with a combined oral contraceptive (norelgestromin and ethinyl estradiol) did not elicit any relevant effects in oral contraceptives exposure. No interaction studies have been performed with oral contraceptives containing other progestogens.

Vaccines

A randomized, open-label study examined the concomitant use of TECFIDERA and several non-live vaccines in adults 27-55 years of age with relapsing forms of MS (38 subjects undergoing treatment with TECFIDERA at the time of vaccination and 33 subjects undergoing treatment with non-pegylated interferon at the time of vaccination). Concomitant exposure to TECFIDERA did not attenuate antibody responses to tetanus toxoid-containing vaccine, pneumococcal polysaccharide, and meningococcal vaccines relative to antibody responses in interferon-treated patients. The impact of these findings on vaccine effectiveness in this patient population is unknown. The safety and effectiveness of live or live-attenuated vaccines administered concomitantly with TECFIDERA have not been assessed.

13 NONCLINICAL TOXICOLOGY

13.1 Carcinogenesis, Mutagenesis, Impairment of Fertility

Carcinogenesis

Carcinogenicity studies of dimethyl fumarate (DMF) were conducted in mice and rats. In mice, oral administration of DMF (25, 75, 200, and 400 mg/kg/day) for up to two years resulted in an increase in nonglandular stomach (forestomach) and kidney tumors: squamous cell carcinomas and papillomas of the forestomach in males and females at 200 and 400 mg/kg/day; leiomyosarcomas of the forestomach at 400 mg/kg/day in males and females; renal tubular adenomas and carcinomas at 200 and 400 mg/kg/day in males; and renal tubule adenomas at 400 mg/kg/day in females. Plasma MMF exposure (AUC) at the highest dose not associated with tumors in mice (75 mg/kg/day) was similar to that in humans at the recommended human dose (RHD) of 480 mg/day.

In rats, oral administration of DMF (25, 50, 100, and 150 mg/kg/day) for up to two years resulted in increases in squamous cell carcinomas and papillomas of the forestomach at all doses tested in males and females, and in testicular interstitial (Leydig) cell adenomas at 100 and 150 mg/kg/day. Plasma MMF AUC at the lowest dose tested was lower than that in humans at the RHD.

Mutagenesis

Dimethyl fumarate (DMF) and monomethyl fumarate (MMF) were not mutagenic in the *in vitro* bacterial reverse mutation (Ames) assay. DMF and MMF were clastogenic in the *in vitro* chromosomal aberration assay in human peripheral blood lymphocytes in the absence of metabolic activation. DMF was not clastogenic in the *in vivo* micronucleus assay in the rat.

Impairment of Fertility

In male rats, oral administration of DMF (75, 250, and 375 mg/kg/day) prior to and throughout the mating period had no effect on fertility; however, increases in non-motile sperm were observed at the mid and high doses. The no-effect dose for adverse effects on sperm is similar to the recommended human dose (RHD) of 480 mg/day on a body surface area (mg/m²) basis.

In female rats, oral administration of DMF (20, 100, and 250 mg/kg/day) prior to and during mating and continuing to gestation day 7 caused disruption of the estrous cycle and increases in embryoletality at the highest dose tested. The highest dose not associated with adverse effects (100 mg/kg/day) is twice the RHD on a mg/m² basis.

Testicular toxicity (germinal epithelial degeneration, atrophy, hypospermia, and/or hyperplasia) was observed at clinically relevant doses in mice, rats, and dogs in subchronic and chronic oral toxicity studies of DMF, and in a chronic oral toxicity study evaluating a combination of four fumaric acid esters (including DMF) in rats.

13.2 Animal Toxicology and/or Pharmacology

Kidney toxicity was observed after repeated oral administration of dimethyl fumarate (DMF) in mice, rats, dogs, and monkeys. Renal tubule epithelia regeneration, suggestive of tubule epithelial injury, was observed in all species. Renal tubular hyperplasia was observed in rats with dosing for up to two years. Cortical atrophy and interstitial fibrosis were observed in dogs and monkeys at doses above 5 mg/kg/day. In monkeys, the highest dose tested (75 mg/kg/day) was associated with single cell necrosis and multifocal and diffuse interstitial fibrosis, indicating irreversible loss of renal tissue and function. In dogs and monkeys, the 5 mg/kg/day dose was associated with plasma MMF exposures less than or similar to that in humans at the recommended human dose (RHD).

A dose-related increase in incidence and severity of retinal degeneration was observed in mice following oral administration of DMF for up to two years at doses above 75 mg/kg/day, a dose associated with plasma MMF exposure (AUC) similar to that in humans at the RHD.

14 CLINICAL STUDIES

The efficacy and safety of TECFIDERA were demonstrated in two studies (Studies 1 and 2) that evaluated TECFIDERA taken either twice or three times a day in patients with relapsing-remitting multiple sclerosis (RRMS). The starting dose for TECFIDERA was 120 mg twice or three times a day for the first 7 days, followed by an increase to 240 mg twice or three times a day. Both studies included patients who had experienced at least 1 relapse over the year preceding the trial or had a brain Magnetic Resonance Imaging (MRI) scan demonstrating at least one gadolinium-enhancing (Gd⁺) lesion within 6 weeks of randomization. The Expanded Disability Status Scale (EDSS) was also assessed and patients could have scores ranging from 0 to 5. Neurological evaluations were performed at baseline, every 3 months, and at the time of suspected relapse. MRI evaluations were performed at baseline, month 6, and year 1 and 2 in a subset of patients (44% in Study 1 and 48% in Study 2).

Study 1: Placebo-Controlled Trial in RRMS

Study 1 was a 2-year randomized, double-blind, placebo-controlled study in 1234 patients with RRMS. The primary endpoint was the proportion of patients relapsed at 2 years. Additional endpoints at 2 years included the number of new or newly enlarging T2 hyperintense lesions, number of new T1 hypointense lesions, number of Gd+ lesions, annualized relapse rate (ARR), and time to confirmed disability progression. Confirmed disability progression was defined as at least a 1 point increase from baseline EDSS (1.5 point increase for patients with baseline EDSS of 0) sustained for 12 weeks.

Patients were randomized to receive TECFIDERA 240 mg twice a day (n=410), TECFIDERA 240 mg three times a day (n=416), or placebo (n=408) for up to 2 years. The median age was 39 years, median time since diagnosis was 4 years, and median EDSS score at baseline was 2. The median time on study drug for all treatment arms was 96 weeks. The percentages of patients who completed 96 weeks on study drug per treatment group were 69% for patients assigned to TECFIDERA 240 mg twice a day, 69% for patients assigned to TECFIDERA 240 mg three times a day and 65% for patients assigned to placebo groups.

TECFIDERA had a statistically significant effect on all of the endpoints described above and the 240 mg three times daily dose showed no additional benefit over the TECFIDERA 240 mg twice daily dose. The results for this study (240 mg twice a day vs. placebo) are shown in [Table 2](#) and [Figure 1](#).

Table 2: Clinical and MRI Results of Study 1

	TECFIDERA 240 mg BID	Placebo	P-value
Clinical Endpoints	N=410	N=408	
Proportion relapsing (primary endpoint)	27%	46%	<0.0001
Relative risk reduction	49%		
Annualized relapse rate	0.172	0.364	<0.0001
Relative reduction	53%		
Proportion with disability progression	16%	27%	0.0050
Relative risk reduction	38%		
MRI Endpoints	N=152	N=165	
Mean number of new or newly enlarging T2 lesions over 2 years	2.6	17	<0.0001
Percentage of subjects with no new or newly enlarging lesions	45%	27%	

	TECFIDERA 240 mg BID	Placebo	P-value
Number of Gd+ lesions at 2 years Mean (median)	0.1 (0)	1.8 (0)	
Percentage of subjects with			
0 lesions	93%	62%	
1 lesion	5%	10%	
2 lesions	<1%	8%	
3 to 4 lesions	0	9%	
5 or more lesions	<1%	11%	
Relative odds reduction (percentage)	90%		<0.0001
Mean number of new T1 hypointense lesions over 2 years	1.5	5.6	<0.0001

Figure 1: Time to 12-Week Confirmed Progression of Disability (Study 1)

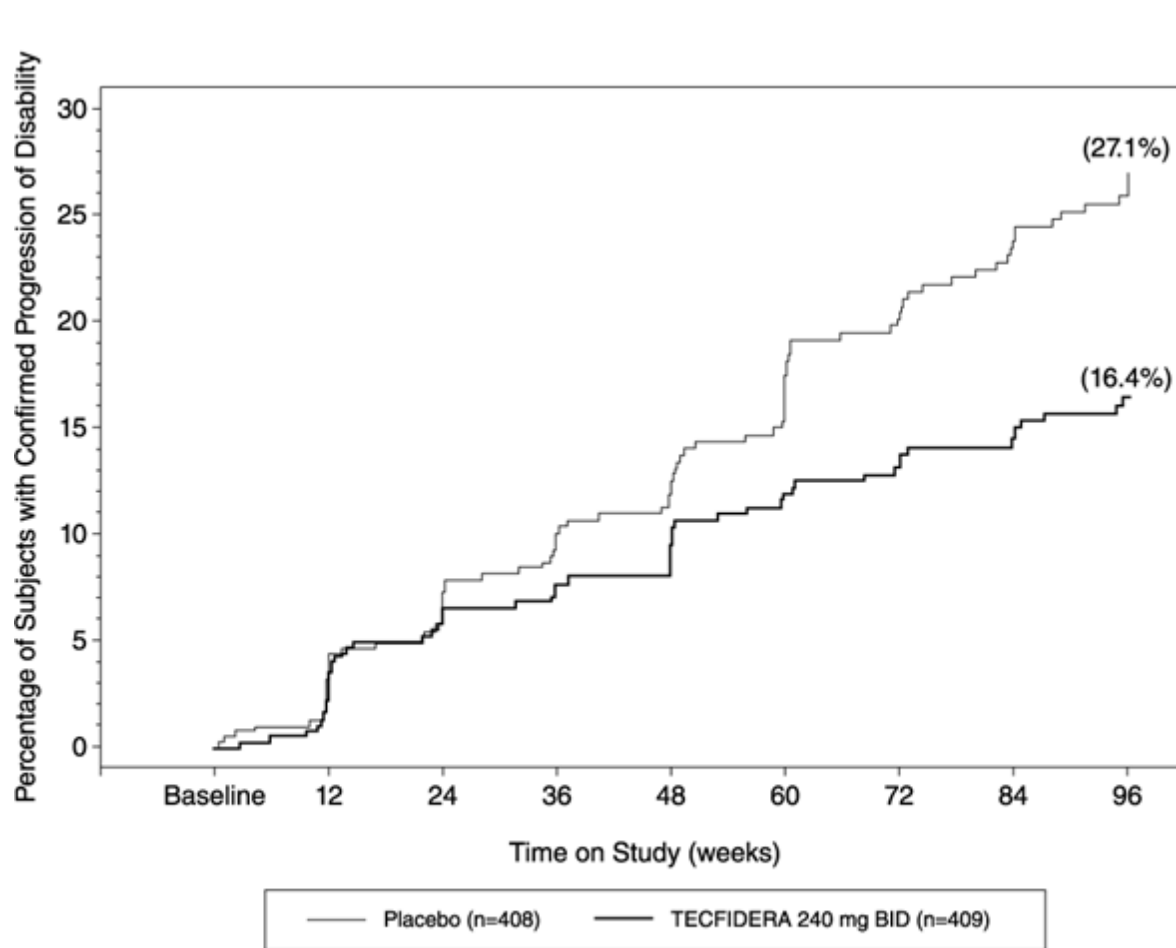

NOTE: Confirmed progression of disability is defined as at least 1.0 point increase on the EDSS from a baseline EDSS \geq 1.0 confirmed for 12 weeks or at least 1.5 point increase on the EDSS from a baseline EDSS of 0 confirmed for 12 weeks.

Study 2: Placebo-Controlled Trial in RRMS

Study 2 was a 2-year multicenter, randomized, double-blind, placebo-controlled study that also included an open-label comparator arm in patients with RRMS. The primary endpoint was the annualized relapse rate at 2 years. Additional endpoints at 2 years included the number of new or newly enlarging T2 hyperintense lesions, number of T1 hypointense lesions, number of Gd+ lesions, proportion of patients relapsed, and time to confirmed disability progression as defined in Study 1.

Patients were randomized to receive TECFIDERA 240 mg twice a day (n=359), TECFIDERA 240 mg three times a day (n=345), an open-label comparator (n=350), or placebo (n=363) for up to 2 years. The median age was 37 years, median time since diagnosis was 3 years, and median EDSS score at baseline was 2.5. The median time on study drug for all treatment arms was 96 weeks. The percentages of patients who completed 96 weeks on study drug per treatment group were 70% for patients assigned to TECFIDERA 240 mg twice a day, 72% for patients assigned to TECFIDERA 240 mg three times a day and 64% for patients assigned to placebo groups.

TECFIDERA had a statistically significant effect on the relapse and MRI endpoints described above. There was no statistically significant effect on disability progression. The TECFIDERA 240 mg three times daily dose resulted in no additional benefit over the TECFIDERA 240 mg twice daily dose. The results for this study (240 mg twice a day vs. placebo) are shown in [Table 3](#).

Table 3: Clinical and MRI Results of Study 2

	TECFIDERA 240 mg BID	Placebo	P-value
Clinical Endpoints	N=359	N=363	
Annualized relapse rate	0.224	0.401	<0.0001
Relative reduction	44%		
Proportion relapsing	29%	41%	0.0020
Relative risk reduction	34%		
Proportion with disability progression	13%	17%	0.25
Relative risk reduction	21%		
MRI Endpoints	N=147	N=144	
Mean number of new or newly enlarging T2 lesions over 2 years	5.1	17.4	<0.0001
Percentage of subjects with no new or newly enlarging lesions	27%	12%	
Number of Gd+ lesions at 2 years			
Mean (median)	0.5 (0.0)	2.0 (0.0)	
Percentage of subjects with 0 lesions	80%	61%	

	TECFIDERA 240 mg BID	Placebo	P-value
1 lesion	11%	17%	
2 lesions	3%	6%	
3 to 4 lesions	3%	2%	
5 or more lesions	3%	14%	
Relative odds reduction (percentage)	74%		<0.0001
Mean number of new T1 hypointense lesions over 2 years	3.0	7.0	<0.0001

16 HOW SUPPLIED/STORAGE AND HANDLING

TECFIDERA is available as hard gelatin delayed-release capsules in two strengths containing either 120 mg or 240 mg of dimethyl fumarate. The green and white 120 mg capsules are printed with “BG-12 120 mg” in black ink. The green 240 mg capsules are printed with “BG-12 240 mg” in black ink. TECFIDERA is available as follows:

30-day Starter Pack, (NDC 64406-007-03):

7-day bottle 120 mg capsules, quantity 14

23-day bottle 240 mg capsules, quantity 46

120 mg capsules:

7-day bottle of 14 capsules (NDC 64406-005-01)

240 mg capsules:

30-day bottle of 60 capsules (NDC 64406-006-02)

Store at 15°C to 30°C (59 to 86°F). Protect the capsules from light. Store in original container.

17 PATIENT COUNSELING INFORMATION

Advise the patient to read the FDA-approved patient labeling (Patient Information)

Dosage

Inform patients that they will be provided two strengths of TECFIDERA when starting treatment: 120 mg capsules for the 7 day starter dose and 240 mg capsules for the maintenance dose, both to be taken twice daily. Inform patients to swallow TECFIDERA capsules whole and intact. Inform patients to not crush, chew, or sprinkle capsule contents on food. Inform patients that TECFIDERA can be taken with or without food [*see Dosage and Administration (2.1)*].

Anaphylaxis and Angioedema

Advise patients to discontinue TECFIDERA and seek medical care if they develop signs and symptoms of anaphylaxis or angioedema [see *Warnings and Precautions (5.1)*].

Progressive Multifocal Leukoencephalopathy

Inform patients that progressive multifocal leukoencephalopathy (PML) has occurred in patients who received TECFIDERA. Inform the patient that PML is characterized by a progression of deficits and usually leads to death or severe disability over weeks or months. Instruct the patient of the importance of contacting their doctor if they develop any symptoms suggestive of PML. Inform the patient that typical symptoms associated with PML are diverse, progress over days to weeks, and include progressive weakness on one side of the body or clumsiness of limbs, disturbance of vision, and changes in thinking, memory, and orientation leading to confusion and personality changes [see *Warnings and Precautions (5.2)*].

Herpes Zoster and Other Serious Opportunistic Infections

Inform patients that herpes zoster and other serious opportunistic infections have occurred in patients who received TECFIDERA. Instruct the patient of the importance of contacting their doctor if they develop any signs or symptoms associated with herpes zoster or other serious opportunistic infections [see *Warnings and Precautions (5.3)*].

Lymphocyte Counts

Inform patients that TECFIDERA may decrease lymphocyte counts. A blood test should be obtained before they start therapy. Blood tests are also recommended after 6 months of treatment, every 6 to 12 months thereafter, and as clinically indicated [see *Warnings and Precautions (5.4)*, *Adverse Reactions (6.1)*].

Liver Injury

Inform patients that TECFIDERA may cause liver injury. Instruct patients treated with TECFIDERA to report promptly any symptoms that may indicate liver injury, including fatigue, anorexia, right upper abdominal discomfort, dark urine, or jaundice. A blood test should be obtained before patients start therapy and during treatment, as clinically indicated [see *Warnings and Precautions (5.5)*].

Flushing and Gastrointestinal (GI) Reactions

Flushing and GI reactions (abdominal pain, diarrhea, and nausea) are the most common reactions, especially at the initiation of therapy, and may decrease over time. Advise patients to contact their healthcare provider if they experience persistent and/or severe flushing or GI reactions. Advise patients experiencing flushing that taking TECFIDERA with food or taking a non-enteric coated aspirin prior to taking TECFIDERA may help [see *Adverse Reactions (6.1)*].

Pregnancy and Pregnancy Registry

Instruct patients that if they are pregnant or plan to become pregnant while taking TECFIDERA they should inform their physician.

Encourage patients to enroll in the TECFIDERA Pregnancy Registry if they become pregnant while taking TECFIDERA [*see Use in Specific Populations (8.1)*].

41347-12

Manufactured for:
Biogen Inc.
Cambridge, MA 02142

TECFIDERA is a registered trademark of Biogen.

© Biogen 2013 – 2020

Patient Information
TECFIDERA® (tek" fi de' rah)
(dimethyl fumarate) delayed-release capsules

What is TECFIDERA?

- TECFIDERA is a prescription medicine used to treat relapsing forms of multiple sclerosis (MS), to include clinically isolated syndrome, relapsing-remitting disease, and active secondary progressive disease, in adults.
- It is not known if TECFIDERA is safe and effective in children under 18 years of age

Who should not take TECFIDERA?

- Do not use TECFIDERA if you have had an allergic reaction (such as welts, hives, swelling of the face, lips, mouth or tongue, or difficulty breathing) to TECFIDERA or any of its ingredients. See below for a complete list of ingredients.

Before taking and while you take TECFIDERA, tell your doctor if you have or have had:

- low white blood cell counts or an infection
- any other medical conditions

Tell your doctor if you are:

- pregnant or plan to become pregnant. It is not known if TECFIDERA will harm your unborn baby.
 - If you become pregnant while taking TECFIDERA, talk to your doctor about enrolling in the TECFIDERA Pregnancy Registry. You can enroll in this registry by calling 1-866-810-1462 or visiting www.tecfiderapregnancyregistry.com. The purpose of this registry is to monitor the health of you and your baby.
- breastfeeding or plan to breastfeed. It is not known if TECFIDERA passes into your breast milk. You and your doctor should decide if you will take TECFIDERA or breastfeed.
- taking prescription or over-the-counter medicines, vitamins, or herbal supplements

How should I take TECFIDERA?

- Take TECFIDERA exactly as your doctor tells you to take it
- The recommended starting dose is one 120 mg capsule taken by mouth 2 times a day for 7 days
- The recommended dose after 7 days is one 240 mg capsule taken by mouth 2 times a day
- TECFIDERA can be taken with or without food
- Swallow TECFIDERA whole. Do not crush, chew, or sprinkle capsule contents on food.
- Protect TECFIDERA from light. You can do this by storing the capsules in their original container.
- If you take too much TECFIDERA, call your doctor or go to the nearest hospital emergency room right away.

What are the possible side effects of TECFIDERA?

TECFIDERA may cause serious side effects including:

- **allergic reaction** (such as welts, hives, swelling of the face, lips, mouth or tongue, or difficulty breathing)
- **PML** a rare brain infection that usually leads to death or severe disability
- **decreases in your white blood cell count** Your doctor should do a blood test before you start treatment with TECFIDERA and while on therapy.

- **liver problems.** Your doctor should do blood tests to check your liver function before you start taking TECFIDERA and during treatment if needed. Tell your doctor right away if you get any of these symptoms of a liver problem during treatment.
 - severe tiredness
 - loss of appetite
 - pain on the right side of your stomach
 - have dark or brown (tea color) urine
- yellowing of your skin or the white part of your eyes
- **herpes zoster infections (shingles)**, including central nervous system infections
- **other serious infections**

The most common side effects of TECFIDERA include:

- flushing, redness, itching, or rash
- nausea, vomiting, diarrhea, stomach pain, or indigestion
- Flushing and stomach problems are the most common reactions, especially at the start of therapy, and may decrease over time. Taking TECFIDERA with food may help reduce flushing. Call your doctor if you have any of these symptoms and they bother you or do not go away. Ask your doctor if taking aspirin before taking TECFIDERA may reduce flushing.

These are not all the possible side effects of TECFIDERA. Call your doctor for medical advice about side effects. You may report side effects to FDA at 1-800-FDA-1088. **For more information go to dailymed.nlm.nih.gov.**

General Information about the safe and effective use of TECFIDERA

- Medicines are sometimes prescribed for purposes other than those listed in this Patient Information. Do not use TECFIDERA for a condition for which it was not prescribed. Do not give TECFIDERA to other people, even if they have the same symptoms that you have. It may harm them.
- If you would like more information, talk to your doctor or pharmacist. You can ask your doctor or pharmacist for information about TECFIDERA that is written for healthcare professionals.

What are the ingredients in TECFIDERA?

Active ingredient: dimethyl fumarate

Inactive ingredients: microcrystalline cellulose, silicified microcrystalline cellulose, croscarmellose sodium, talc, silica colloidal silicon dioxide, magnesium stearate, triethyl citrate, methacrylic acid copolymer - Type A, methacrylic acid copolymer dispersion, simethicone (30% emulsion), sodium lauryl sulphate, and polysorbate 80. **Capsule Shell:** gelatin, titanium dioxide, FD&C blue 1; brilliant blue FCF, yellow iron oxide and black iron oxide.

Manufactured for: Biogen Inc., Cambridge, MA 02142, www.TECFIDERA.com or call 1-800-456-2255

This Patient Information has been approved by the U.S. Food and Drug Administration. Revised: 12/2019

PRODUCT MONOGRAPH

PrTIVICAY

Dolutegravir (as dolutegravir sodium)

10, 25 and 50 mg tablets

Antiretroviral Agent

ViiV Healthcare ULC
245, boulevard Armand-Frappier
Laval, Quebec
H7V 4A7

Date of Revision:
January 31, 2020

Submission Control No: 233258

© 2020 ViiV Healthcare group of companies or its licensor
Trademarks are owned by or licensed to the ViiV Healthcare group of companies.

TABLE OF CONTENTS

	PAGE
PART I: HEALTH PROFESSIONAL INFORMATION	3
SUMMARY PRODUCT INFORMATION	3
INDICATIONS AND CLINICAL USE	3
CONTRAINDICATIONS	4
WARNINGS AND PRECAUTIONS	4
ADVERSE REACTIONS	7
DRUG INTERACTIONS	14
DOSAGE AND ADMINISTRATION	19
OVERDOSAGE	21
ACTION AND CLINICAL PHARMACOLOGY	22
STORAGE AND STABILITY	27
SPECIAL HANDLING INSTRUCTIONS	27
DOSAGE FORMS, COMPOSITION AND PACKAGING	27
 PART II: SCIENTIFIC INFORMATION	 28
PHARMACEUTICAL INFORMATION	28
CLINICAL TRIALS	28
DETAILED PHARMACOLOGY	40
TOXICOLOGY	46
REFERENCES	47
 PART III: CONSUMER INFORMATION	 50

PrTIVICAY

dolutegravir (as dolutegravir sodium) tablets

PART I: HEALTH PROFESSIONAL INFORMATION

SUMMARY PRODUCT INFORMATION

Route of Administration	Dosage Form / Strength	Clinically Relevant Nonmedicinal Ingredients
Oral	Film-coated tablets / 10, 25 and 50 mg dolutegravir (as dolutegravir sodium)	None <i>For a complete listing, see DOSAGE FORMS, COMPOSITION AND PACKAGING.</i>

INDICATIONS AND CLINICAL USE

TIVICAY, in combination with other antiretroviral agents, is indicated for the treatment of human immunodeficiency virus (HIV-1) infection in adults and in INSTI-naïve children at least 6 years of age and weighing at least 15 kg.

The following should be considered prior to initiating treatment with TIVICAY:

- Poor virologic response was observed in subjects treated with TIVICAY 50mg twice daily with an integrase strand transfer inhibitor (INSTI)-resistance Q148 substitution plus 2 or more additional INSTI-resistance substitutions, including, but not limited to T66A, L74I/M, E138A/K/T, G140A/C/S, Y143R/C/H, E157Q, G163S/E/K/Q, or G193E/R.

Geriatrics (> 65 years of age):

Clinical studies of TIVICAY did not include sufficient numbers of patients aged 65 years and older to determine whether they respond differently from adult patients < 65 years of age.

Pediatrics (aged less than 6 years or weighing less than 15 kg or INSTI-experienced):

Safety and efficacy of TIVICAY have not been established in children aged less than 6 years or weighing less than 15 kg or who are INSTI-experienced with documented or clinical suspected resistance to other INSTIs.

CONTRAINDICATIONS

- Patients who are hypersensitive to this drug or to any ingredient in the formulation or component of the container. For a complete listing, see **DOSAGE FORMS, COMPOSITION AND PACKAGING**.
- TIVICAY is contraindicated in combination with drugs with narrow therapeutic windows, that are substrates of organic cation transporter 2 (OCT2), including but not limited to dofetilide, or fampridine (also known as dalfampridine) (see **DRUG INTERACTIONS**).

WARNINGS AND PRECAUTIONS

General

Patients receiving TIVICAY or any other antiretroviral therapy may still develop opportunistic infections and other complications of HIV infection. Therefore patients should remain under close clinical observation by physicians experienced in the treatment of these associated HIV diseases.

While effective viral suppression with antiretroviral therapy has been proven to substantially reduce the risk of sexual transmission, a residual risk cannot be excluded. Precautions to prevent transmission should be taken in accordance with national guidelines.

Hypersensitivity Reactions

Hypersensitivity reactions have been reported with integrase inhibitors, including TIVICAY, and were characterized by rash, constitutional findings, and sometimes, organ dysfunction, including liver injury. Discontinue TIVICAY and other suspect agents immediately if signs or symptoms of hypersensitivity reactions develop (including, but not limited to, severe rash or rash accompanied by fever, general malaise, fatigue, muscle or joint aches, blisters, oral lesions, conjunctivitis, facial edema, hepatitis, eosinophilia, angioedema). Clinical status including liver aminotransferases should be monitored and appropriate therapy initiated. Delay in stopping treatment with TIVICAY or other suspect agents after the onset of hypersensitivity may result in a life-threatening reaction.

Hepatic/Biliary/Pancreatic

Hepatotoxicity

Cases of hepatic toxicity including elevated serum liver biochemistries, hepatitis, and acute liver failure have been reported in patients receiving a dolutegravir-containing regimen who had no pre-existing hepatic disease or other identifiable risk factors. Drug-induced liver injury leading to liver transplant has been reported with TRIUMEQ (dolutegravir/abacavir/lamivudine). Monitoring for hepatotoxicity is recommended.

Liver chemistry changes in patients with hepatitis B or C co-infection

Patients with underlying hepatitis B or C may be at increased risk for worsening or development of transaminase elevations with use of TIVICAY. Liver chemistry elevations consistent with immune reconstitution inflammatory syndrome were observed in some hepatitis B and/or C co-infected patients at the start of TIVICAY therapy. Monitoring of liver chemistries is recommended in patients with hepatitis B and/or C co-infection. Particular diligence should be applied in initiating or maintaining effective hepatitis B therapy (referring to treatment guidelines) when starting dolutegravir-based therapy in hepatitis B co-infected patients (see **ADVERSE REACTIONS, Clinical Trial Adverse Drug Reactions, Co-infection with Hepatitis B or C**).

Immune

Immune Reconstitution Inflammatory Syndrome (IRIS)

Immune reconstitution inflammatory syndrome has been reported in HIV-infected patients treated with combination antiretroviral therapy, including TIVICAY. During the initial phase of treatment, patients responding to antiretroviral therapy may develop an inflammatory response to indolent or residual opportunistic infections [such as *Mycobacterium avium-complex* (MAC), cytomegalovirus (CMV), *Pneumocystis jirovecii* pneumonia (PCP), and *tuberculosis* (TB)], which may necessitate further evaluation and treatment.

Autoimmune disorders (such as Graves' disease, polymyositis, autoimmune hepatitis and Guillain-Barre syndrome) have also been reported to occur in the setting of immune reconstitution; however, the time to onset is more variable, and can occur many months after initiation of treatment and sometimes can be an atypical presentation.

Special Populations

Pregnant Women: TIVICAY has not been studied in pregnant women. TIVICAY should not be used in pregnant women unless the potential benefits outweigh the potential risks to the fetus (see **TOXICOLOGY, Reproductive Toxicology, Pregnancy**). Women of childbearing potential (WOCBP) should undergo pregnancy testing before initiation of TIVICAY and should be advised to use effective contraception throughout treatment. Initiation of TIVICAY is not recommended in adolescents and adults actively trying to become pregnant unless there is no suitable alternative. If there are plans to become pregnant or if pregnancy is confirmed within the first trimester while on TIVICAY, the risks and benefits of continuing TIVICAY versus switching to another antiretroviral regimen should be assessed and switching to an alternative regimen should be considered. TIVICAY may be considered during the second and third trimesters of pregnancy if the expected benefit justifies the potential risk to the pregnant woman and the fetus.

In a birth outcome surveillance study in Botswana there have been 5 cases of neural tube defects reported in 1,683 deliveries (0.3%) to mothers taking dolutegravir-containing regimens from the time of conception, compared with 15 cases in 14,792 deliveries

(0.1%) to mothers taking non-dolutegravir-containing regimens from the time of conception (Prevalence Difference 0.20%; 95% CI 0.01-0.59). In the same study, one out of 3840 deliveries (0.03%) to mothers who started dolutegravir during pregnancy had a neural tube defect, compared with three out of 5,952 deliveries (0.05%) to mothers who started non dolutegravir-containing regimens during pregnancy. A causal relationship of these events to the use of dolutegravir has not been established. The incidence of neural tube defects in the general population ranges from 0.5-1 case per 1,000 live births. As neural tube defects occur within the first 4 weeks of foetal development (at which time the neural tubes are sealed) this potential risk would concern women exposed to dolutegravir at the time of conception and in early pregnancy.

Data analysed to date from other sources including the Antiretroviral Pregnancy Registry, clinical trials, and post-marketing data are insufficient to address the risk of neural tube defects with dolutegravir. More than 1000 outcomes from second and third trimester exposure in pregnant women indicate no evidence of increased risk of adverse birth outcomes.

In reproductive toxicity studies in animals, dolutegravir was shown to cross the placenta and no evidence of teratogenicity, reproductive function, relevant embryonic or fetal toxicity, including neural tube defects, was identified (see NON-CLINICAL TOXICOLOGY).

Antiretroviral Pregnancy Registry: To monitor maternal-fetal outcomes of pregnant women with HIV exposed to TIVICAY and other antiretroviral agents, an Antiretroviral Pregnancy Registry has been established. Physicians are encouraged to register patients: <http://www.apregistry.com>
Telephone: (800) 258-4263
Fax: (800) 800-1052

Nursing Women: HIV-1-infected mothers should not breast-feed their infants to avoid risking postnatal transmission of HIV. It is expected that dolutegravir will be secreted into human milk based on animal data, although this has not been confirmed in humans. Nursing mothers should be instructed not to breast-feed if they are receiving TIVICAY.

Pediatrics (<18 years of age): TIVICAY is not recommended in pediatric patients aged less than 6 years or weighing less than 15 kg. Safety and efficacy of TIVICAY have not been established in children who were infected with suspected or confirmed INSTI-resistant HIV-1 virus.

Geriatrics (> 65 years of age): Clinical studies of TIVICAY did not include sufficient numbers of patients aged 65 and older to determine whether they respond differently from adult patients less than 65 years of age. In general, caution should be exercised in dose selection for the elderly patients due to the greater frequency of decreased hepatic, renal, or cardiac function, and of concomitant disease or other drug therapy.

ADVERSE REACTIONS

Adverse Drug Reaction Overview

The overall safety profile of TIVICAY is based on over 1500 HIV-infected patients treated with a TIVICAY-based regimen in Phase 2 and 3 clinical studies. The overall safety profile was similar across the treatment-naïve, treatment-experienced (and integrase-naïve) and integrase-resistant patient populations. The most common adverse reactions of moderate to severe intensity and incidence $\geq 2\%$ (in those receiving TIVICAY in any one study) are insomnia, headache, fatigue, nausea, and diarrhea.

Clinical Trial Adverse Drug Reactions

Because clinical trials are conducted under very specific conditions, the adverse reaction rates observed in the clinical trials may not reflect the rates observed in practice and should not be compared to the rates in the clinical trials of another drug. Adverse drug reaction information from clinical trials is useful for identifying drug-related adverse events and for approximating rates.

Treatment-Naïve Patients

The safety assessment of TIVICAY in HIV-1-infected treatment-naïve patients is based on the analyses of 48-week data from two randomized, ongoing, international, multicentre, double-blind studies, SPRING-2 (ING113086) and SINGLE (ING114467).

In SPRING-2, 822 adult patients were randomized and received at least one dose of either TIVICAY 50 mg once daily (QD) or ISENTRESS 400 mg twice daily (BID), both in combination with fixed-dose dual nucleoside reverse transcriptase inhibitor (NRTI) treatment (either abacavir sulfate and lamivudine [KIVEXA] or emtricitabine/tenofovir [TRUVADA]). The rate of adverse events leading to discontinuation was 2% in both treatment arms.

In SINGLE, 833 adult patients were randomized to receive at least one dose of either TIVICAY 50 mg with fixed-dose abacavir and lamivudine (KIVEXA) once daily or fixed-dose efavirenz/emtricitabine/tenofovir (ATRIPLA) once daily. The rate of adverse events leading to discontinuation were 2% in patients receiving TIVICAY 50 mg once daily + KIVEXA and 10% in patients receiving ATRIPLA once daily.

Treatment-emergent adverse reactions (adverse events assessed as causally related by the investigators) of moderate to severe intensity with a $\geq 2\%$ frequency in either treatment arm in SPRING-2 and SINGLE studies are provided in Table 1.

The adverse drug reactions and laboratory abnormalities observed at 96 weeks in SPRING-2 and at 144 weeks in SINGLE were generally consistent with those seen at 48 weeks.

Table 1 Treatment-Emergent Adverse Reactions of at Least Moderate Intensity (Grades 2-4) and \geq 2% Frequency in Treatment-Naïve Patients in SPRING-2 and SINGLE Trials (Through 48 weeks)

Body System/ Preferred Term	SPRING-2		SINGLE	
	TIVICAY 50 mg QD + 2 NRTIs (N = 411)	ISENTRESS 400 mg BID + 2 NRTIs (N = 411)	TIVICAY 50 mg + KIVEXA QD (N = 414)	ATRIPLA QD (N = 419)
Psychiatric				
Insomnia	1 (<1%)	1 (<1%)	13 (3%)	9 (2%)
Abnormal dreams	1 (<1%)	1 (<1%)	2 (<1%)	8 (2%)
Nervous System				
Dizziness	1 (<1%)	1 (<1%)	2 (<1%)	19 (5%)
Headache	3 (<1%)	4 (<1%)	7 (2%)	9 (2%)
Gastrointestinal				
Nausea	6 (1%)	5 (1%)	3 (<1%)	12 (3%)
Diarrhea	2 (<1%)	2 (<1%)	4 (<1%)	7 (2%)
Skin and Subcutaneous Tissue				
Rash	0	2 (<1%)	1 (<1%)	14 (3%)
Ear and Labyrinth				
Vertigo	0	1 (<1%)	0	7 (2%)

Antiretroviral-Experienced and Integrase Inhibitor-Naïve Patients

In an international, multicentre, double-blind study (ING111762, SAILING), 719 HIV-1-infected, antiretroviral treatment-experienced adults were randomized to receive either TIVICAY 50 mg once daily or ISENTRESS 400 mg twice daily with investigator-selected background regimen (BR) consisting of up to 2 agents, including at least one fully active agent. At 48 weeks, the rates of adverse events leading to discontinuation were 2% (7/357) in patients receiving TIVICAY 50 mg once daily + BR and 4% (13/362) in patients receiving ISENTRESS 400 mg twice daily + BR.

Through 48 wks, the only treatment-emergent adverse reaction of moderate to severe intensity with a \geq 2% frequency in either treatment group was diarrhea, 2% (6/357) in subjects receiving TIVICAY 50 mg once daily + BR and 1% (5/362) in subjects receiving ISENTRESS 400 mg twice daily + BR.

Integrase Inhibitor-Resistant Patients

In a multicentre, open-label, single-arm study (ING112574, VIKING-3), 183 HIV-1-infected, antiretroviral treatment-experienced adults with virologic failure with current or historical evidence of raltegravir and/or elvitegravir resistance received TIVICAY 50 mg twice daily with the current failing background regimen for 7 days and with Optimized Background Therapy (OBT) from Day 8. The rate of discontinuation due to adverse events was 4% of patients at the Week 48 analysis.

Treatment-emergent adverse reactions (adverse events assessed as causally related by the investigator) of moderate to severe intensity with a $\geq 2\%$ frequency are listed in Table 2.

Table 2 Treatment-Emergent Adverse Reactions of at Least Moderate Intensity (Grades 2 to 4) and $\geq 2\%$ Frequency in Integrase Inhibitor-Resistant Patients in the VIKING-3 Study (Week 24 and Week 48 Analyses)

Body System/ Preferred Term	Week 24	Week 48
	TIVICAY 50 mg BID + OBT (N = 183)	TIVICAY 50 mg BID + OBT (N = 183)
Gastrointestinal		
Diarrhea	4 (2%)	4 (2%)
Nausea	3 (2%)	3 (2%)
Nervous System		
Headache	3 (2%)	2 (1%)

Co-infection with Hepatitis B or C

In Phase III studies, patients with hepatitis B and/or C co-infection were permitted to enrol provided that baseline liver chemistry tests did not exceed 5 times the upper limit of normal (ULN). Overall, the safety profile in patients co-infected with hepatitis B and/or C was similar to that observed in patients without hepatitis B or C co-infection, although the rates of AST and ALT abnormalities were higher in the subgroup with hepatitis B and/or C co-infection for all treatment groups. Grades 2 to 4 ALT abnormalities in hepatitis B and/or C co-infected patients compared with HIV mono-infected patients receiving TIVICAY were observed in 18% vs. 3% with the 50 mg once-daily dose and 13% vs. 9% with the 50 mg twice-daily dose. Liver chemistry elevations consistent with immune reconstitution inflammatory syndrome were observed in some subjects with hepatitis B and/or C co-infection at the start of dolutegravir therapy, particularly in those whose anti-hepatitis B therapy was withdrawn (see **WARNINGS AND PRECAUTIONS, Hepatic/Biliary/Pancreatic, Liver chemistry changes in patients with hepatitis B or C co-infection**).

Pediatrics

TIVICAY is being studied in an ongoing Phase I/II, 48-week multicentre, open-label non-comparative study to evaluate the pharmacokinetic parameters, safety, tolerability, and efficacy of dolutegravir in combination regimens in HIV-1 infected INSTI-naive infants, children, and adolescents (IMPAACT P1093).

Based on limited data in 46 children and adolescents (6 to 18 years of age and weighing at least 15 kg) over 48 weeks, the ADR profile was similar to that for adults. Grade 2 ADRs reported by more than one subject were decreased neutrophil count (n = 3) and diarrhea (n = 2). There were no Grade 3 or 4 drug-related ADRs reported. No ADRs led to discontinuation.

Grade 3 or 4 laboratory abnormalities reported in more than one subject were elevated total bilirubin (n=3) and decreased neutrophil count (n=2). The change in mean serum creatinine was similar to that observed in adults.

Less Common Clinical Trial Adverse Drug Reactions (< 2%)

The following treatment-emergent adverse reactions occurred in < 2% of treatment-naïve or treatment-experienced adult patients in any one study receiving TIVICAY in a combination regimen. These events have been included because of their assessment of potential causal relationship and/or severity:

Gastrointestinal Disorders: Abdominal pain, abdominal discomfort, flatulence, upper abdominal pain, vomiting

General Disorders: Fatigue

Hepatobiliary Disorders: Hepatitis

Immune System Disorders: Hypersensitivity, immune reconstitution inflammatory syndrome

Skin and Subcutaneous Tissue Disorders: Pruritus

Musculoskeletal and Connective Tissue Disorders: Myalgia, myositis

Psychiatric Disorders: Depression, suicidal ideation or suicide attempt (particularly in patients with a pre-existing history of depression or psychiatric illness)

Renal and Urinary Disorders: Renal impairment

Abnormal Hematologic and Clinical Chemistry Findings

A summary of laboratory abnormalities are presented below by the treatment population.

Treatment-Naïve Patients

Selected laboratory abnormalities, with a worsening grade from baseline in $\geq 2\%$ (Grades 2 to 4) of patients in SPRING-2 and SINGLE studies are presented in Table 3.

Table 3 Selected Laboratory Abnormalities (Grades 2 to 4) in Treatment-Naïve Patients in SPRING-2 and SINGLE Studies (Analysis through 48 Weeks)

Laboratory Parameter Preferred Term (Unit)	SPRING-2		SINGLE	
	TIVICAY 50 mg QD+ 2 NRTIs (N = 411)	ISENTRESS 400 mg BID + 2 NRTIs (N = 411)	TIVICAY 50 mg + KIVEXA QD (N = 414)	ATRIPLA QD (N = 419)
ALT (IU/L)				
Grade 2 (>2.5-5.0 x ULN)	8 (2%)	14 (3%)	9 (2%)	20 (5%)
Grade 3 to 4 (>5.0 x ULN)	9 (2%)	7 (2%)	1 (<1%)	2 (<1%)
AST (IU/L)				
Grade 2 (>2.5-5.0 x ULN)	15 (4%)	14 (3%)	7 (2%)	13 (3%)
Grade 3 to 4 (>5.0 x ULN)	11 (2%)	9 (2%)	0	10 (2%)
Total Bilirubin (µmol/L)				
Grade 2 (1.6-2.5 x ULN)	8 (2%)	8 (2%)	2 (<1%)	1 (<1%)
Grade 3 to 4 (>2.5 x ULN)	2 (<1%)	1 (<1%)	1 (<1%)	1 (<1%)
Creatine kinase (IU/L)				
Grade 2 (6.0-9.9 x ULN)	8 (2%)	14 (3%)	15 (4%)	7 (2%)
Grade 3 to 4 (≥10.0 x ULN)	20 (5%)	14 (3%)	11 (3%)	19 (5%)
Hyperglycemia (mmol/L)				
Grade 2 (6.95-13.88 mmol/L)	24 (6%)	23 (6%)	28 (7%)	19 (5%)
Grade 3 to 4 (>13.88 mmol/L)	2 (<1%)	6 (1%)	6 (1%)	1 (<1%)
Lipase (U/L)				
Grade 2 (>1.5-3.0 x ULN)	23 (6%)	25 (6%)	33 (8%)	30 (7%)
Grade 3 to 4 (>3.0 x ULN)	7 (2%)	14 (3%)	11 (3%)	8 (2%)
Phosphorus, inorganic (mmol/L)				
Grade 2 (0.65-0.80 mmol/L)	34 (8%)	48 (12%)	37 (9%)	52 (12%)
Grade 3 to 4 (<0.65mmol/L)	5 (1%)	7 (2%)	5 (1%)	12 (3%)
Total neutrophils (10 ³ /µL)				
Grade 2 (0.75-0.99 x 10 ⁹)	15 (4%)	11 (3%)	10 (2%)	15 (4%)
Grade 3 to 4 (<0.75 x 10 ⁹)	8 (2%)	7 (2%)	7 (2%)	12 (3%)

ULN = Upper limit of normal.

The mean change from baseline observed for selected lipid values is presented in Table 4.

Table 4 Mean Change from Baseline in Fasted Lipid Values in Treatment-Naïve Subjects in SPRING-2 and SINGLE Studies (Week 48 Analysis)

Laboratory Parameter Preferred Term (Unit)	SPRING-2		SINGLE	
	TIVICAY 50 mg QD + 2 NRTIs (N = 411)	ISENTRES S 400 mg BID + 2 NRTIs (N = 411)	TIVICAY 50 mg + KIVEXA QD (N = 414)	ATRIPLA QD (N = 419)
Cholesterol (mmol/L)*	0.18	0.23	0.44	0.62
HDL cholesterol (mmol/L)	0.07	0.07	0.14	0.21
LDL cholesterol** (mmol/L)	0.08	0.09	0.22	0.34
Total cholesterol/HDL (ratio)	-0.04	-0.05	-0.09	-0.10
Triglycerides (mmol/L)	0.10	0.10	0.20	0.21

SINGLE Study: p-value versus ATRIPLA at Week 48; p-value adjusted for baseline value and stratification factors: *p=0.005, **p=0.032

Treatment-experienced and Integrase Inhibitor-Naïve Patients

Selected laboratory abnormalities, with a worsening grade from baseline, in $\geq 2\%$ (Grades 2 to 4) of patients are presented in Table 5. The mean change from baseline observed for lipid values was similar across both treatment groups at Week 48.

Table 5 Selected Laboratory Abnormalities (Grades 2 to 4) in Antiretroviral Treatment-Experienced and Integrase Inhibitor-Naïve Patients in the SAILING Trial (Week 48 Analysis)

Laboratory Parameter Preferred Term (Unit)	TIVICAY 50 mg QD + BR ^a (N = 357)	ISENTRESS 400 mg BID + BR ^a (N = 362)
ALT (IU/L)		
Grade 2 (>2.5-5.0 x ULN)	13 (4%)	9 (2%)
Grade 3 to 4 (>5.0 x ULN)	9 (3%)	7 (2%)
AST (IU/L)		
Grade 2 (>2.5-5.0 x ULN)	7 (2%)	16 (4%)
Grade 3 to 4 (>5.0 x ULN)	12 (3%)	5 (1%)
Bilirubin (μmol/L)		
Grade 2 (1.6-2.5 x ULN)	23 (6%) ^b	26 (7%) ^b
Grade 3 to 4 (>2.5 x ULN)	21 (6%) ^b	14 (4%) ^b
Creatine kinase (IU/L)		
Grade 2 (6.0-9.9 x ULN)	4 (1%)	8 (2%)
Grade 3 to 4 (≥10.0 x ULN)	7 (2%)	4 (1%)
Hyperglycemia (mmol/L)		
Grade 2 (6.95-13.88 mmol/L)	32 (9%)	25 (7%)
Grade 3 to 4 (>13.88 mmol/L)	4 (1%)	7 (2%)
Lipase (U/L)		
Grade 2 (>1.5-3.0 x ULN)	26 (7%)	30 (8%)
Grade 3 to 4 (>3.0 x ULN)	4 (1%)	7 (2%)
Total neutrophils (10 ³ /μL)		
Grade 2 (0.75-0.99 x 10 ⁹)	12 (3%)	10 (3%)
Grade 3 to 4 (<0.75 x 10 ⁹)	12 (3%)	10 (3%)

^a Background Regimen

^b Grade 2: 20/23 on dolutegravir and 23/26 on raltegravir received atazanavir.

Grade 3 to 4: 16/21 on dolutegravir and 11/14 on raltegravir received atazanavir.

ULN = Upper limit of normal.

Treatment-experienced and Integrase Inhibitor-Resistant Patients

In VIKING-3 at Week 48, treatment-emergent changes in clinical chemistry to Grade 3 events occurred in 21% (39/183) of patients and 5% (10/183) had a Grade 4 event. The most common laboratory abnormality was Grade 3 to 4 elevated creatine kinase (5%, 9/183). Two percent (4/183) of patients had a Grade 3 to 4, treatment-emergent hematology laboratory abnormality, with neutropenia (2%, 3/183) being the most frequently reported.

Changes in Clinical Laboratory Values

Dolutegravir has been shown to increase serum creatinine due to inhibition of tubular secretion of creatinine without affecting renal glomerular function. Increases in serum creatinine occurred within the first 4 weeks of treatment with TIVICAY and remained stable through 48 weeks. In treatment-naïve patients a mean change from baseline of 9.96 µmol/L (range: -53 µmol/L to 54.8 µmol/L) was observed after 48 weeks of treatment. Creatinine increases were comparable by background NRTIs, and were similar in treatment-experienced patients (see **ACTION AND CLINICAL PHARMACOLOGY, Pharmacodynamics, Effects on Renal Function**).

Increases in total bilirubin (without clinical jaundice) were observed on TIVICAY and ISENTRESS (but not efavirenz) arms in the programme. These changes of -0.04 µmol/L (range -24 µmol/L to 14 µmol/L) are not considered clinically relevant as they likely reflect competition between dolutegravir and unconjugated bilirubin for a common clearance pathway (UGT1A1) (see **ACTION AND CLINICAL PHARMACOLOGY, Pharmacokinetics, Metabolism**).

In Phase III studies, Grade 3 to 4 creatine phosphokinase (CPK) abnormalities were reported 3% to 5% in treatment-naïve patients, 2% in treatment-experienced INSTI-naïve subjects, and 4% in INSTI-resistant patients with TIVICAY therapy. Cases of myalgia or myositis with concurrent CPK elevations have been reported and relationship with the use of TIVICAY could not be excluded.

Post-Market Adverse Drug Reactions

Hepatobiliary disorders: acute hepatic failure

Musculoskeletal and connective tissue disorders: arthralgia, myalgia

Psychiatric disorders: anxiety*

*In a post marketing analysis of clinical trial data, the total number of anxiety cases seen with TIVICAY therapy was 4% (n=1672), versus the total number of anxiety cases seen with comparator arms of 5% (n=1681).

Investigations: weight increased

DRUG INTERACTIONS

Overview

Effect of Dolutegravir on the Pharmacokinetics of Other Agents

In vitro, dolutegravir inhibited the renal organic cation transporter, OCT2 (IC₅₀ = 1.93 micromolar), multidrug and toxin extrusion transporter (MATE) 1 (IC₅₀ = 6.34 micromolar) and MATE2-K (IC₅₀ = 24.8 micromolar). Dolutegravir has a low potential to affect the transport of MATE2-K substrates. *In vivo*, dolutegravir inhibits tubular secretion of creatinine by inhibiting OCT2. Based on this observation, TIVICAY may

increase plasma concentrations of drugs in which excretion is dependent upon OCT2 (for example dofetilide, fampridine (also known as dalfampridine) [see **CONTRAINDICATIONS**], metformin) or MATE1 (see Table 6).

In vitro, dolutegravir inhibited the basolateral renal transporters: organic anion transporter (OAT) 1 ($IC_{50} = 2.12$ micromolar) and OAT3 ($IC_{50} = 1.97$ micromolar). Based upon the dolutegravir unbound plasma concentration, *in silico* modelling and no notable effect on the *in vivo* pharmacokinetics of the OAT substrates tenofovir and para aminohippurate, dolutegravir thus has a low propensity to cause drug interactions via inhibition of OAT transporters.

In vitro, dolutegravir did not inhibit ($IC_{50} > 50$ μ M) the enzymes: cytochrome P₄₅₀ (CYP)1A2, CYP2A6, CYP2B6, CYP2C8, CYP2C9, CYP2C19, CYP2D6, CYP3A, uridine diphosphate glucuronosyl transferase (UGT)1A1 or UGT2B7, or transporters: P-glycoprotein (Pgp), breast cancer resistance protein (BCRP), bile salt export pump (BSEP), organic anion transporter polypeptide (OATP)1B1, OATP1B3, OCT1, or multidrug resistance protein (MRP)2 or MRP4. *In vitro*, dolutegravir did not induce CYP1A2, CYP2B6, or CYP3A4. Based on these data, TIVICAY is not expected to affect the pharmacokinetics of drugs that are substrates of these enzymes or transporters.

In drug interaction studies, dolutegravir did not have a clinically relevant effect on the pharmacokinetics of the following: midazolam, tenofovir, methadone, rilpivirine, daclatasvir and oral contraceptives containing norgestimate and ethinyl estradiol. Using cross-study comparisons to historical pharmacokinetic data for each interacting drug, dolutegravir did not appear to affect the pharmacokinetics of the following drugs: atazanavir, darunavir, efavirenz, etravirine, fosamprenavir, lopinavir, ritonavir, boceprevir, and telaprevir.

Effect of Other Agents on the Pharmacokinetics of Dolutegravir

Dolutegravir is metabolized by UGT1A1 with some contribution from CYP3A. Dolutegravir is also a substrate of UGT1A3, UGT1A9, CYP3A4, Pgp, and BCRP *in vitro*; therefore drugs that induce those enzymes and transporters, may decrease dolutegravir plasma concentration and reduce the therapeutic effect of dolutegravir.

Co-administration of dolutegravir and other drugs that inhibit UGT1A1, UGT1A3, UGT1A9, CYP3A4, and/or Pgp may increase dolutegravir plasma concentration (see Table 6).

In vitro, dolutegravir is not a substrate of human OATP1B1, OATP1B3, or OCT1, therefore drugs that solely modulate these transporters are not expected to affect dolutegravir plasma concentration.

Etravirine significantly reduced plasma concentrations of dolutegravir but the effect of etravirine was mitigated by co-administration of lopinavir/ritonavir or darunavir/ritonavir, and is expected to be mitigated by atazanavir/ritonavir.

Tenofovir, nelfinavir, lopinavir/ritonavir, darunavir/ritonavir, rilpivirine, boceprevir, telaprevir, prednisone, rifabutin, daclatasvir and omeprazole had no clinically significant effect on dolutegravir pharmacokinetics.

Established and Other Potentially Significant Drug Interactions

Selected drug interactions are presented in Table 6. Recommendations are based on either drug interaction studies or predicted interactions due to the expected magnitude of interaction and potential for serious adverse events or loss of efficacy.

Table 6 Established or Potential Drug-Drug Interactions

Concomitant Drug Class: Drug Name	Effect on Concentration of Dolutegravir and/or Concomitant Drug	Clinical Comment
HIV-1 Antiviral Agents		
Non-nucleoside Reverse Transcriptase Inhibitor: Etravirine (ETR)	Dolutegravir↓ ETR↔	The recommended dose of TIVICAY is 50 mg twice daily when co-administered with etravirine without boosted protease inhibitors. No dose adjustment is needed in these patients if etravirine is taken with atazanavir/ritonavir, darunavir/ritonavir, or lopinavir/ritonavir. TIVICAY should only be used with etravirine when co-administered with atazanavir/ritonavir, darunavir/ritonavir or lopinavir/ritonavir in INSTI resistant patients.
Non-nucleoside Reverse Transcriptase Inhibitor: Efavirenz (EFV) ^a	Dolutegravir↓ EFV ↔	The recommended dose of TIVICAY is 50 mg twice daily when co-administered with efavirenz in ART-naïve and ART-experienced, INSTI-naïve patients. Alternative combinations that do not include efavirenz should be used where possible in INSTI-resistant patients. ^b In pediatric patients, increase the weight-based dose to twice daily (Table 8).
Non-nucleoside Reverse Transcriptase Inhibitor: Nevirapine	Dolutegravir↓	Co-administration with nevirapine should be avoided because there are insufficient data to make a dosing recommendation.
Protease Inhibitor: Atazanavir (ATV)	Dolutegravir↑ ATV ↔	Atazanavir increased dolutegravir plasma concentration. No dose adjustment is necessary.
Protease Inhibitor: Atazanavir/ritonavir (ATV/RTV)	Dolutegravir↑ ATV↔ RTV↔	Atazanavir/ritonavir increased dolutegravir plasma concentration. No dose adjustment is necessary.

Concomitant Drug Class: Drug Name	Effect on Concentration of Dolutegravir and/or Concomitant Drug	Clinical Comment
Protease Inhibitor: Tipranavir/ritonavir ^a (TPV+RTV)	Dolutegravir↓ TPV ↔	The recommended dose of TIVICAY is 50 mg twice daily when co-administered with tipranavir/ritonavir in ART-naïve and ART-experienced, INSTI-naïve patients. In pediatric patients, increase the weight-based dose to twice daily (Table 8). Alternative combinations that do not include tipranavir/ritonavir should be used where possible in INSTI-resistant patients. ^b
Protease Inhibitor: Fosamprenavir/ritonavir ^a (FPV/RTV)	Dolutegravir↓ FPV ↔ RTV ↔	A dose adjustment to 50 mg twice daily is recommended in ART-naïve and ART-experienced, INSTI-naïve adult patients. In pediatric patients, increase the weight-based dose to twice daily (Table 8). Alternative combinations that do not include fosamprenavir/ritonavir should be used where possible in INSTI-resistant patients. ^b
Other Agents		
Antiarrhythmic: Dofetilide	Dofetilide ↑	Co-administration of dolutegravir has the potential to increase dofetilide plasma concentration via inhibition of OCT2 transporter; co-administration has not been studied. TIVICAY and dofetilide co-administration is contraindicated due to potential life-threatening toxicity caused by high dofetilide concentration.
Potassium channel blocker: Fampridine (also known as dalfampridine)	Fampridine/dalfampridine↑	Co-administration is contraindicated with TIVICAY due to potential for seizures associated with fampridine/dalfampridine.

Concomitant Drug Class: Drug Name	Effect on Concentration of Dolutegravir and/or Concomitant Drug	Clinical Comment
Anticonvulsants: Oxcarbazepine Phenytoin Phenobarbital Carbamazepine	Dolutegravir ↓	The recommended dose of TIVICAY is 50 mg twice daily in adults when co-administered with these metabolic inducers. In pediatric patients, increase the weight-based dose to twice daily (Table 8). Co-administration with these metabolic inducers should be avoided in INSTI-resistant patients.
Medications containing polyvalent cations (e.g. Mg or Al) Cation-containing antacids ^a or laxative, sucralfate, buffered medications	Dolutegravir ↓	TIVICAY is recommended to be administered 2 hours before or 6 hours after taking medications containing polyvalent cations.
Calcium and iron supplements ^a	Dolutegravir ↓	When taken with food, TIVICAY and calcium and/or iron supplements or multivitamins containing calcium and/or iron can be taken at the same time. Under fasting conditions, TIVICAY should be taken 2 hours before or 6 hours after taking supplements containing calcium and/or iron.
Metformin	Metformin ↑	Consider metformin dose adjustments when starting or stopping concomitant treatment to maintain glycemic control.
Rifampin ^a	Dolutegravir ↓	The recommended dose of TIVICAY is 50 mg twice daily when co-administered with rifampin in ART-naïve and ART-experienced, INSTI-naïve adult patients. In pediatric patients, increase the weight-based dose to twice daily (Table 8). Alternatives to rifampin should be used where possible for INSTI-resistant patients. ^b

^a See **DETAILED PHARMACOLOGY, Pharmacokinetics** for magnitude of interaction (Table 19 and Table 20).

^b The lower dolutegravir exposure when co-administered with potential metabolic inducers may result in loss of therapeutic effect and development of resistance to dolutegravir or other co-administered antiretroviral agents in patients with suspected or confirmed INSTI-resistance.

Drug-Food Interactions

TIVICAY may be administered with or without food (see **ACTION AND CLINICAL PHARMACOLOGY, Pharmacokinetics, Effects of Food on Oral Absorption**).

Drug-Herb Interactions

No interaction study has been conducted, however, St. John's Wort is a potent CYP3A inducer and may potentially decrease dolutegravir plasma concentration. In adults, TIVICAY 50 mg twice daily may be considered when taken together with St. John's Wort. St. John's Wort should be avoided in INSTI-resistant patients. In pediatric patients the weight-based, once-daily dose should be administered twice-daily.

Drug-Laboratory Interactions

No Drug-Laboratory interactions have been identified.

DOSAGE AND ADMINISTRATION

Dosing Considerations

As with all antiretroviral drugs, dolutegravir therapy should be initiated by a healthcare practitioner experienced in the management of HIV infection.

Dolutegravir can be taken with or without food. The 10 mg tablet strength is not interchangeable with the 25 mg or the 50 mg tablet strengths.

Perform pregnancy testing before initiation of TIVICAY in individuals of childbearing potential.

Recommended Dose

Adult Patients

Table 7 Recommended Dosing Regimen in Adults

Patient Population	Dose	Regimen
Treatment-naïve ^a	50 mg	QD*
Treatment-experienced, INSTI-naïve ^a	50 mg	QD
Treatment-experienced, INSTI-resistant ^b	50 mg	BID**

* QD – once daily

** BID – twice daily

^a The dose of TIVICAY is 50 mg twice daily when co-administered with potent UGT1A/CYP3A inducers, including efavirenz, tipranavir/ritonavir, fosamprenavir/ritonavir or rifampin (see **DRUG INTERACTIONS**).

^b Alternative combinations that do not include metabolic inducers should be used where possible for INSTI-resistant patients. The safety and efficacy of doses above 50 mg twice daily have not been evaluated (see **DRUG INTERACTIONS**).

Pediatric Patients

Treatment-naïve or Treatment-experienced INSTI-naïve

The recommended dose of TIVICAY in pediatric patients aged at least 6 years and weighing at least 15 kg is provided in Table 8.

Safety and efficacy of TIVICAY have not been established in pediatric patients aged less than 6 years or weighing less than 15 kg, or who are INSTI-experienced with suspected or confirmed INSTI-resistant HIV-1.

Table 8 Recommended Dosing Regimen in pediatric patients

Body Weight (kg)	Once Daily Dosing Regimen^a
15 to less than 20	20 mg (Two 10 mg tablets)
20 to less than 30	25 mg
30 to <40	35 mg (one 25 mg tablet and one 10 mg tablet)
≥40	50 mg (one 50 mg tablet)

^a If certain UGT1A or CYP3A inducers including efavirenz, tipranavir/ritonavir, fosamprenavir/ritonavir or rifampin are coadministered, then increase the weight-based dose of TIVICAY to twice daily (see **DRUG INTERACTIONS**).

Geriatrics

There are limited data available on the use of TIVICAY in patients aged 65 years and older. In general, caution should be exercised in the administration of TIVICAY in elderly patients reflecting the greater frequency of decreased hepatic, renal, or cardiac function, and of concomitant disease or other drug therapy.

Renal impairment

Dolutegravir plasma concentrations were decreased in subjects with severe renal impairment compared with those in matched healthy controls. No dosage adjustment is required in INSTI-naïve patients with mild, moderate or severe ($\text{CrCl} < 30 \text{ mL/min}$, not on dialysis) renal impairment. Caution is advised for INSTI-resistant patients with severe renal impairment as the decreased dolutegravir exposure may result in loss of therapeutic effect and development of resistance to dolutegravir. There is limited information on dolutegravir in patients receiving dialysis (see **ACTION AND CLINICAL PHARMACOLOGY, Special Populations and Conditions, Renal Impairment**).

Hepatic impairment

No dosage adjustment is required in patients with mild or moderate hepatic impairment (Child-Pugh Score A or B). The effect of severe hepatic impairment (Child-Pugh Score C) on the pharmacokinetics of dolutegravir has not been studied. Therefore, dolutegravir is not recommended for use in patients with severe hepatic impairment (Child-Pugh Score C) (see **ACTION AND CLINICAL PHARMACOLOGY, Special Populations and Conditions, Hepatic Impairment**).

Missed Dose

If a dose is missed, patients should take the missed dose as soon as possible unless it is within 4 hours of their next scheduled dose. If a dose is skipped, the patient should not double the next dose.

OVERDOSAGE

For management of a suspected drug overdose, contact your regional Poison Control Centre.

Symptoms and signs

There is currently limited experience with overdosage in dolutegravir.

Limited experience of single higher doses (up to 250 mg in healthy subjects) revealed no specific symptoms or signs, apart from those listed as adverse reactions.

Treatment

There is no specific treatment for an overdose of dolutegravir. If overdose occurs, the patient should be closely monitored and treated supportively as necessary. As TIVICAY is highly bound to plasma proteins, it is unlikely that it will be significantly removed by dialysis.

ACTION AND CLINICAL PHARMACOLOGY

Mechanism of Action

Dolutegravir inhibits HIV integrase by binding to the integrase active site and blocking the strand transfer step of retroviral Deoxyribonucleic acid (DNA) integration, which is essential for the HIV replication cycle. *In vitro*, dolutegravir dissociates slowly from the active site of the wild-type integrase-DNA complex ($t_{1/2}$ 71 hours). Strand transfer biochemical assays using purified HIV-1 integrase and pre-processed substrate DNA resulted in IC_{50} values of 2.7 nM and 12.6 nM.

Pharmacodynamics

In a randomized, dose-ranging trial, HIV-1-infected subjects treated with dolutegravir monotherapy (ING111521) demonstrated rapid and dose-dependent antiviral activity, with mean declines from baseline to Day 11 in HIV-1 RNA of 1.5, 2.0, and 2.5 \log_{10} for dolutegravir 2 mg, 10 mg, and 50 mg once daily, respectively. This antiviral response was maintained for 3 to 4 days after the last dose in the 50 mg group.

Effects on Electrocardiogram: In a randomized, placebo-controlled, cross-over trial, 42 healthy subjects received single-dose oral administrations of placebo, dolutegravir 250 mg suspension (exposures approximately 3-fold of the 50 mg once-daily dose at steady state), and moxifloxacin (400 mg, active control) in random sequence. After baseline and placebo adjustment, the maximum mean QTc change based on Fridericia correction method (QTcF) was 1.99 msec (1-sided 95% upper CI: 4.53 msec). TIVICAY did not prolong the QTc interval for 24 hours post-dose.

Effects on Renal Function: The effect of dolutegravir on serum creatinine clearance (CrCl), glomerular filtration rate (GFR) using iohexol as the probe and effective renal plasma flow (ERPF) using para-aminohippurate (PAH) as the probe was evaluated in an open-label, randomized, 3-arm, parallel, placebo-controlled study in 37 healthy subjects, who were administered dolutegravir 50 mg once daily (n=12), 50 mg twice daily (n=13) or placebo once daily (n=12) for 14 days. A decrease in CrCl, as determined by 24-hour urine collection, was observed with both doses of dolutegravir (9% and 13%, for dolutegravir 50 mg once daily and twice daily, respectively). Dolutegravir had no significant effect on GFR or ERPF at either dose level.

Pharmacokinetics

The pharmacokinetic properties of dolutegravir have been evaluated in healthy adult patients and HIV-1-infected adult patients. Dolutegravir pharmacokinetics is generally similar between healthy subjects and HIV-infected patients. The non-linear exposure of dolutegravir following 50 mg twice daily compared with 50 mg once daily in HIV-1-infected patients (Table 9) was attributed to the use of metabolic inducers in their background antiretroviral regimens (e.g. darunavir/ritonavir) of subjects receiving dolutegravir 50 mg twice daily. Dolutegravir was administered without regard to food in these trials.

Table 9 Steady-State Dolutegravir Pharmacokinetic Parameter Estimates in HIV-1-Infected Adults

Parameter	50 mg QD Geometric mean (% CV) ^a	50 mg BID Geometric mean (% CV) ^b
AUC ₍₀₋₂₄₎ (mcg.hr/mL)	53.6 (27)	75.1 (35)
C _{max} (mcg/mL)	3.67 (20)	4.15 (29)
C _{min} (mcg/mL)	1.11 (46)	2.12 (47)

^a Based on population pharmacokinetic analyses using data from SPRING-1 AND SPRING-2

^b Based on population pharmacokinetic analyses using data from VIKING and VIKING-3

Absorption: Following oral administration peak plasma concentrations were observed 2 to 3 hours post-dose for the tablet formulation. With once-daily dosing, pharmacokinetic steady state is achieved within approximately 5 days of dosing with average accumulation ratios for AUC, C_{max}, C_{24 hr} ranging from 1.2 to 1.5. Dolutegravir plasma concentration increased in a less than dose proportional manner above 50 mg. The absolute bioavailability of dolutegravir has not been established.

Effects of Food on Oral Absorption: Dolutegravir may be administered with or without food. Food increased the extent of absorption and slowed the rate of absorption of dolutegravir. Low, moderate, and high fat meals increased dolutegravir AUC_(0-∞) by 33%, 41%, and 66%, increased C_{max} by 46%, 52%, and 67%, prolonged T_{max} to 3, 4, and 5 hours from 2 hours under fasted conditions, respectively.

Distribution: Dolutegravir is highly bound ($\geq 98.9\%$) to human plasma proteins based on *in vivo* data and binding is independent of plasma dolutegravir concentration. The apparent volume of distribution (Vd/F) following 50 mg once daily oral administration was estimated at 17.4 L based on population pharmacokinetic analysis.

Cerebrospinal Fluid (CSF): In 12 treatment-naïve subjects on dolutegravir plus abacavir/lamivudine, the median dolutegravir concentration in CSF was 18 ng/mL (ranging from 4 to 23 ng/mL) 2 to 6 hours post-dose after 2 weeks of treatment. The clinical relevance of this finding has not been established.

Metabolism: Dolutegravir is primarily metabolized via UGT1A1 with some contribution from CYP3A. Renal elimination of unchanged drug was low (< 1% of the dose). After a single oral dose of [¹⁴C] dolutegravir, 53% of the total oral dose was excreted unchanged in the faeces. Thirty-one percent of the total oral dose was excreted in the urine, represented by an ether glucuronide of dolutegravir (18.9% of total dose), N-dealkylation metabolite (3.6% of total dose), and a metabolite formed by oxidation at the benzylic carbon (3.0% of total dose).

Elimination: Dolutegravir has a terminal half-life of approximately 14 hours and an apparent clearance (CL/F) of 0.9-1.05 L/hr based on population pharmacokinetic analyses.

Special Populations and Conditions

Pediatrics: The pharmacokinetics, safety, virologic and immunologic responses were evaluated in 46 treatment-experienced, integrase-inhibitor naïve, HIV-1 infected patients aged 6 to <18 years (weighing ≥ 15 kg), who received TIVICAY in an open-label, multicentre, dose-finding non-comparative clinical trial; IMPAACT P1093. The pharmacokinetics results showed that the response to TIVICAY in treatment-experienced, INSTI- naïve HIV-1 infected children and adolescents weighing at least 15 kg was similar to HIV-1-infected adults receiving 50 mg once daily (Table 10). Dosing in the ≥15 to ≤20kg weight band is based on population PK modelling and simulation analysis. See **DOSAGE AND ADMINISTRATION**, **Dosing Considerations**, **Pediatric Patients**.

Table 10 Dolutegravir Steady-State Pharmacokinetic Parameters in Pediatric Subjects

Weight (n)	Dose of TIVICAY	Dolutegravir Pharmacokinetic Parameter Estimates		
		Geometric Mean (%CV)		
		C _{max} (mcg/mL)	AUC ₍₀₋₂₄₎ (mcg.h/mL)	C ₂₄ (mcg/mL)
≥40 kg (n = 14)	50 mg once daily	3.89 (43)	50.1 (53)	0.99 (66)
≥30 to <40 kg (n = 3)	35 mg once daily	4.40 (54)	64.6 (64)	1.33 (93)
≥20 to <30 kg (n = 4)	25 mg once daily	2.84 (51)	34.1 (46)	0.52 (44)
≥15 to <20 kg ^a	20 mg once daily	4.29	51.6	1.06

^a Based on population pharmacokinetic analyses using data from IMPAACT P1093.

Population pharmacokinetic analyses demonstrate comparable exposures in children, at least 15 kg, dosed by weight-bands (20 mg, 25 mg, 35 mg, or 50 mg of dolutegravir) to that observed in adults.

See also **ADVERSE REACTIONS, Clinical Trial Adverse Drug Reactions, Pediatrics**; and **CLINICAL TRIALS, Pediatric**.

Geriatrics: Population pharmacokinetic analysis using pooled pharmacokinetic data from adult studies indicated age had no clinically relevant effect on the pharmacokinetics of dolutegravir.

Gender: Population PK analyses using pooled pharmacokinetic data from adult studies revealed no clinically relevant effect of gender on the exposure of dolutegravir.

Race: Population PK analyses using pooled pharmacokinetic data from Phase IIb and Phase III adult studies revealed no clinically relevant effect of race on the exposure of dolutegravir.

Hepatic Impairment: Dolutegravir is primarily metabolized and eliminated by the liver. In a study comparing 8 subjects with moderate hepatic impairment (Child-Pugh Score B) to 8 matched healthy adult controls, exposure of dolutegravir from a single 50 mg dose was similar between the two groups. No dosage adjustment is necessary for patients with mild to moderate hepatic impairment (Child-Pugh Score A or B). The effect of severe hepatic impairment (Child-Pugh Score C) on the pharmacokinetics of dolutegravir has not been studied. Therefore, dolutegravir is not recommended for use in patients with severe hepatic impairment.

Renal Impairment: Renal clearance of unchanged drug is a minor pathway of elimination for dolutegravir. In a study comparing 8 subjects with severe renal impairment (CrCL<30 mL/min) to 8 matched healthy controls, the mean AUC, C_{max} and C₂₄ of dolutegravir in renally impaired subjects were decreased by 40%, 23% and 43%, respectively. No dosage adjustment is necessary for INSTI-naïve patients with renal impairment or INSTI-experienced patients with mild to moderate renal impairment. Caution is advised for INSTI-experienced patients with severe renal impairment, as the reduced dolutegravir plasma concentrations may result in loss of therapeutic effect and development of resistance. There is limited information on dolutegravir in patients on dialysis.

Polymorphisms in Drug Metabolizing Enzymes: In a meta-analysis using pharmacogenomics samples collected in clinical studies in healthy subjects, subjects with UGT1A1 (n=7) genotypes conferring poor dolutegravir metabolism had a 32% lower clearance of dolutegravir and 46% higher AUC compared with subjects with genotypes associated with normal metabolism via UGT1A1 (n=41).

Hepatitis B/Hepatitis C Co-infection: Population analyses using pooled pharmacokinetic data from adult studies indicated no clinically relevant effect of hepatitis C co-infection on the pharmacokinetics of dolutegravir. There were limited data on hepatitis B co-infection.

STORAGE AND STABILITY

Store TIVICAY 10, 25 and 50 mg up to 30°C.

Store TIVICAY 10 mg tablets in the original package in order to protect from moisture. Keep the bottle tightly closed. Do not remove the silica gel desiccant.

SPECIAL HANDLING INSTRUCTIONS

There are no special requirements for use or handling of this product.

DOSAGE FORMS, COMPOSITION AND PACKAGING

Dosage Forms

TIVICAY 10 mg tablets are white, round, film-coated, biconvex tablets debossed with 'SV 572' on one side and '10' on the other side. Each tablet contains 10 mg dolutegravir (as dolutegravir sodium).

TIVICAY 25 mg tablets are pale yellow, round, film-coated, biconvex tablets debossed with 'SV 572' on one side and '25' on the other side. Each tablet contains 25 mg dolutegravir (as dolutegravir sodium).

TIVICAY 50 mg tablets are yellow, round, film-coated, biconvex tablets debossed with 'SV 572' on one side and '50' on the other side. Each tablet contains 50 mg dolutegravir (as dolutegravir sodium).

Composition

Each film-coated tablet of TIVICAY for oral administration contains 10.5, 26.3 or 52.6 mg of dolutegravir sodium, which is equivalent to 10, 25 or 50 mg dolutegravir free acid, respectively, and the following inactive ingredients: D-mannitol, microcrystalline cellulose, povidone K29/32, sodium starch glycolate, and sodium stearyl fumarate. The tablet film-coating contains the inactive ingredients iron oxide yellow (25 mg and 50 mg tablets only), macrogol/PEG, polyvinyl alcohol – part hydrolyzed, talc, and titanium dioxide.

Packaging

TIVICAY 10, 25 and 50 mg are available in 60 cc bottles containing 30 tablets. TIVICAY 10 mg tablets contain a silica gel desiccant.

PART II: SCIENTIFIC INFORMATION

PHARMACEUTICAL INFORMATION

Drug Substance

Proper name: dolutegravir sodium

Chemical name:

sodium (4*R*,12*aS*)-9- {[(2,4-difluorophenyl)methyl]carbamoyl} -4-methyl-6,8-dioxo-3,4,6,8,12,12*a*-hexahydro-2*H*-pyrido[1',2':4,5]pyrazino[2,1-*b*][1,3]oxazin-7-olate

Molecular formula: C₂₀H₁₈F₂N₃NaO₅

Molecular mass: 441.36 g/mol

Structural formula:

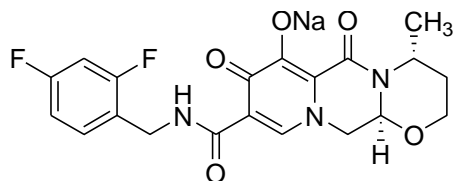

Physicochemical properties: Dolutegravir sodium is a white to light yellow powder and is slightly soluble in water.

CLINICAL TRIALS

The efficacy of TIVICAY in treatment-naïve, HIV-1-infected patients (n=1,655), is based on analyses of data from two studies, SPRING-2 (ING113086) and SINGLE (ING114467). The efficacy of TIVICAY in treatment-experienced, INSTI-naïve (n=715) and INSTI-resistant (n=183), HIV-1-infected patients is based on analyses of data from one study, SAILING (ING111762) and one study, VIKING-3 (ING112574), respectively. The use of TIVICAY in pediatric patients aged 6 years and older is based on evaluation of safety, pharmacokinetics and efficacy through 48 weeks in a multicentre, open-label trial in patients without INSTI-resistance (n=46).

Treatment-Naïve Patients

The efficacy of dolutegravir in HIV-infected, therapy-naïve subjects is based on the analyses of 48-week data from two randomized, international, double-blind, active-controlled trials, SPRING-2 (ING113086) and SINGLE (ING114467).

In SPRING-2, 822 adults were randomized and received at least one dose of either TIVICAY 50 mg once daily or ISENTRESS 400 mg twice daily, both administered with fixed-dose dual NRTI therapy (either KIVEXA [ABC/3TC] or TRUVADA [TDF/FTC]).

In SINGLE, 833 patients were randomized and received at least one dose of either TIVICAY 50 mg once daily with fixed-dose abacavir-lamivudine (KIVEXA) or fixed-dose efavirenz-tenofovir-emtricitabine (EFV/TDF/FTC, ATRIPLA). Table 11 shows baseline characteristics of patients in the SPRING-2 study and SINGLE study. The baseline characteristics were similar between treatment groups. Side-by-side tabulation is to simplify presentation; direct comparisons across studies should not be made due to differing study designs.

Table 11 Baseline Population Characteristics in ART-Naïve, HIV-1-Infected Adult Patients (SPRING-2 and SINGLE)

Demographic Characteristics	SPRING-2		SINGLE	
	TIVICAY 50 mg QD N=411 n (%)	ISENTRESS 400 mg BID N=411 n (%)	TIVICAY 50 mg + ABC/3TC QD N=414 n (%)	ATRIPLA QD N=419 n (%)
Age in Years, median (range)	37 (18-68)	35 (18-75)	36 (18-68)	35 (18-85)
Sex				
Male	348 (85)	355 (86)	347 (84)	356 (85)
Female	63 (15)	56 (14)	67 (16)	63 (15)
Race				
African American/African Heritage	49 (12)	39 (9)	98 (24)	99 (24)
American Indian or Alaska Native	7 (2)	9 (2)	13 (3)	17 (4)
White – White/Caucasian/European Heritage	346 (84)	352 (86)	284 (69)	285 (68)
Median Baseline HIV-1 RNA (log₁₀ c/mL)	4.52	4.58	4.67	4.70
≤100,000	297 (72)	295 (72)	280 (68)	288 (69)
>100,000	114 (28)	116 (28)	134 (32)	131 (31)
Median Baseline CD4+ (cells/mm³)	359.0	362.0	334.5	339.0
<200	55 (13)	50 (12)	57 (14)	62 (15)
200 to <350	144 (35)	139 (34)	163 (39)	159 (38)
≥350	212 (52)	222 (54)	194 (47)	198 (47)
Hepatitis B and/or C co-infection^a				
B only*	7 (2)	8 (2)	-	-
C only	41 (10)	35 (9)	27 (7)	29 (7)
B and C*	1 (<1)	0	-	-
Neither	359 (87)	363 (89)	385 (93)	385 (92)
CDC Category				
A: Asymptomatic or lymphadenopathy or acute HIV	359 (87)	347 (84)	343 (83)	350 (84)
B: Symptomatic, not AIDS	43 (10)	55 (13)	53 (13)	52 (12)
C: AIDS	9 (2)	9 (2)	18 (4)	17 (4)

a. Denominator reflects subjects with result for hepatitis B or hepatitis C; for ISENTRESS arm, N=410

* Hepatitis B co-infection is one of the exclusion criteria in the SINGLE study

Week 48 outcomes (including outcomes by key baseline covariates) for SPRING-2 and SINGLE are shown in Table 12 .

Table 12 Virologic Outcomes of SPRING-2 and SINGLE at 48 Weeks (Snapshot algorithm)

	SPRING-2		SINGLE	
	TIVICAY 50 mg QD + 2 NRTI N=411 n (%)	ISENTRESS 400 mg BID + 2 NRTI N=411 n (%)	TIVICAY 50 mg + KIVEXA QD N=414 n (%)	ATRIPLA QD N=419 n (%)
HIV-1 RNA <50 copies/mL	361 (88)	351 (85)	364 (88)	338 (81)
Treatment Difference*	2.5% (95% CI: -2.2%, 7.1%)		7.4% (95% CI: 2.5%, 12.3%), p = 0.003	
Virologic non-response†	20 (5)	31 (8)	21 (5)	26 (6)
No virologic data at Week 48 window	30 (7)	29 (7)	29 (7)	55 (13)
Reasons:				
Discontinued study/study drug due to adverse event or death‡	9 (2)	6 (1)	9 (2)	40 (10)
Discontinued study/study drug for other reasons§	21 (5)	23 (6)	20 (5)	14 (3)
Missing data during window but on study	0	0	0	1 (<1)
HIV-1 RNA <50 copies/mL by Baseline Plasma Viral Load (copies/mL)	n / N (%)	n / N (%)	n / N (%)	n / N (%)
≤100,000	267 / 297 (90)	264 / 295 (89)	253 / 280 (90)	238 / 288 (83)
>100,000	94 / 114 (82)	87 / 116 (75)	111 / 134 (83)	100 / 131 (76)
HIV-1 RNA <50 copies/mL by Baseline CD4+ (cells/ mm³)				
<200	43 / 55 (78)	34 / 50 (68)	45 / 57 (79)	48 / 62 (77)
200 to <350	128 / 144 (89)	118 / 139 (85)	143 / 163 (88)	126 / 159 (79)
≥350	190 / 212 (90)	199 / 222 (90)	176 / 194 (91)	164 / 198 (83)
HIV RNA <50 copies/mL by NRTI backbone				
KIVEXA [ABC/3TC]	145 / 169 (86)	142 / 164 (87)	364 / 414 (88)	N/A
TRUVADA [TDF/FTC]	216 / 242 (89)	209 / 247 (85)	N/A	338 / 419 (81)
HIV RNA <50 copies/mL by baseline HIV-RNA and NRTI backbone				
≤100,000 c/mL, ABC/3TC	115/132 (87)	110/125 (88)	253 / 280 (90)	N/A
≤100,000 c/mL, TDF/FTC	152/165 (92)	154/170 (91)	N/A	238 / 288 (83)
>100,000 c/mL, ABC/3TC	30/37 (81)	32/39 (82)	111 / 134 (83)	N/A
>100,000 c/mL, TDF/FTC	64/77 (83)	55/77 (71)	N/A	100 / 131 (76)
Gender				
Male	308 / 348 (88)	305 / 355 (86)	307 / 347 (88)	291 / 356 (82)
Female	53 / 63 (84)	46 / 56 (82)	57 / 67 (85)	47 / 63 (75)
Race				
White	306 / 346 (88)	301 / 352 (86)	255 / 284 (90)	238 / 285 (84)
Non white	55 / 65 (85)	50 / 59 (85)	109 / 130 (84)	99 / 133 (74)

	SPRING-2		SINGLE	
	TIVICAY 50 mg QD + 2 NRTI N=411 n (%)	ISENTRESS 400 mg BID + 2 NRTI N=411 n (%)	TIVICAY 50 mg + KIVEXA QD N=414 n (%)	ATRIPLA QD N=419 n (%)
Age (years)				
<50	324 / 370 (88)	312 / 365 (85)	319 / 361 (88)	302 / 375 (81)
≥50	37 / 41 (90)	39 / 46 (85)	45 / 53 (85)	36 / 44 (82)
<p>* Adjusted for baseline stratification factors. † Includes patients who changed BR to new class or changed BR not permitted per protocol or due to lack of efficacy prior to Week 48 (for SPRING-2 only), patients who discontinued prior to Week 48 for lack or loss of efficacy and patients who are ≥50 copies in the 48 week window. ‡ Includes patients who discontinued due to an adverse event or death at any time point from Day 1 through the Week 48 window if this resulted in no virologic data on treatment during the Week 48 window. § Includes reasons such as withdrew consent, loss to follow-up, moved, protocol deviation. Notes: ABC/3TC = abacavir 600 mg, lamivudine 300 mg in the form of Kivexa/Epzicom fixed dose combination (FDC) EFV/TDF/FTC = efavirenz 600 mg, tenofovir 300 mg, emtricitabine 200 mg in the form of Atripla FDC. N = Number of patients in each treatment group</p> <p><u>Snapshot algorithm:</u> Subjects whose last HIV-1 RNA result was <50 c/mL in the analysis window (ie, 48 ± 6 weeks) were counted as responders; subjects who were not suppressed or did not have data at the analysis time point were counted as non-responders. The SPRING-2 protocol allowed one switch in backbone NRTI for management of toxic effects; patients who switched NRTI after week 4 were regarded as non-responders according to the Snapshot algorithm.</p>				

In the SPRING-2 study, at 48 weeks, virologic suppression (HIV-1 RNA < 50 copies/mL) in the dolutegravir group (88%) was non-inferior to the raltegravir group (85%) (non-inferiority margin – 10%; treatment difference 2.5% 95 CI: -2.2%, 7.1%). Virologic suppression treatment differences were comparable across baseline characteristics (gender, race, age, ART backbone, and baseline viral load) at 48 weeks.

The median changes in CD4+ T cell count from baseline were + 230 cells/mm³ in the group receiving TIVICAY and the ISENTRESS group at 48 weeks.

Virologic suppression was maintained through 96 weeks (the proportion of subjects achieving HIV-1 RNA <50 copies/mL was 81% for the dolutegravir group and 76% for the raltegravir group, treatment difference 4.5% (95CI: -1.1%, 10.0%)). The median change in CD4+ T cell count from baseline to 96 weeks was 276 cell/mm³ in the dolutegravir group compared to 264 cells/mm³ in the ISENTRESS group

In the SINGLE study, there was a statistically significant difference in the proportion of subjects achieving viral suppression (HIV-1 RNA <50 copies/mL) between the group receiving TIVICAY + KIVEXA (88%) compared to the ATRIPLA group (81%) based on the primary 48-week analysis (7.4% 95% CI: 2.5%, 12.3% p=0.003). The virologic suppression treatment differences were comparable across baseline characteristics (gender, race, and age) at Week 48.

At Week 48, the adjusted mean change in CD4+ T cell count from baseline were 267 cells/mm³ in the group receiving TIVICAY + KIVEXA and 208 cells/mm³ for the ATRIPLA arm. The adjusted difference and 95% CI were statistically significant at Week 48 [58.9 (33.4, 84.4; p<0.001)] (repeated measure model adjusting for the baseline stratification factors: baseline HIV-1 RNA and baseline CD4+ T cell count, among other factors). This analysis was pre-specified and the Week 48 analysis was adjusted for multiplicity.

The median time to viral suppression was 28 days in the group receiving TIVICAY + KIVEXA and 84 days in the ATRIPLA arm in SINGLE at 48 weeks (p<0.0001). At 28 days (Week 4), 63% of patients in the TIVICAY arm reached virologic suppression, compared to 14% in the ATRIPLA arm.

Virologic suppression was maintained through 96 weeks (the proportion of subjects achieving HIV-1 RNA <50 copies/mL was 80% for the dolutegravir + KIVEXA group and 72% for the ATRIPLA group (treatment difference 8.0%, 95CI: 2.3%, 13.8%, p=0.006)). The adjusted mean change in CD4+ T cell count from baseline was 325 cells/mm³ in the group receiving TIVICAY + KIVEXA, which continued to be statistically significantly different from the ATRIPLA arm (281 cells/mm³) (treatment difference 44 cells/mm³ (95% CI: 14.34, 73.55) p=0.004).

Virologic suppression was maintained through 144 weeks (open-label phase week 96 to 144 week). The proportion of subjects achieving HIV-1 RNA<50 copies/mL was 71% for the dolutegravir + KIVEXA group and 63% for the ATRIPLA group (treatment difference 8.3% (95% CI: 2.0%, 14.6%, p=0.010)). The adjusted mean change in CD4+ T cell count from baseline was 378 cells/mm³ in the group receiving TIVICAY + KIVEXA, which continued to be statistically significantly different from the ATRIPLA arm (332 cells/mm³) (treatment difference 47 cells/mm³ (95% CI: 15.61, 78.20) p=0.003).

Through 96 weeks in SPRING-2 and 144 weeks in SINGLE, no INSTI-resistant mutations or treatment-emergent resistance in background therapy were isolated on the oltegravir-containing arms.

Treatment-Experienced (and Integrase Inhibitor-Naïve) Patients

In the international, multicentre, double-blind SAILING study (ING111762), 719 HIV-1-infected, treatment-experienced adults were randomized and received either TIVICAY 50 mg once daily or ISENTRESS 400 mg twice daily with investigator selected background regimen consisting of up to 2 agents (including at least one fully active agent). All patients had at least two-class ART resistance, and 49% of subjects had at least 3-class ART resistance at baseline. The baseline characteristics were similar between treatment groups. The baseline characteristics for patients in the SAILING study are shown in Table 13.

Table 13 Baseline Population Characteristics (SAILING)

Demographic Characteristics	TIVICAY 50 mg QD N=354 n (%)	ISENTRESS 400 mg BID N = 361 n (%)
Age (years)		
Median (Range)	42 (21-69)	43 (18-73)
Sex		
Female	107 (30)	123 (34)
Male	247 (70)	238 (66)
Race		
African American/African heritage	143 (41)	160 (44)
American Indian or Alaska native	10 (3)	17 (5)
White – White/Caucasian/European Heritage	175 (50)	172 (48)
CDC Classification		
A: Asymptomatic or lymphadenopathy or acute HIV	111 (31)	114 (32)
B: Symptomatic, not AIDS	70 (20)	89 (25)
C: AIDS	173 (49)	158 (44)
Hepatitis B and/or C co-infection		
B only	17 (5)	16 (4)
C only	31 (9)	48 (13)
B and C	1 (<1)	1 (<1)
Neither	288 (81)	271 (75)
Clade		
B	241 (68)	245 (68)
C	55 (16)	48 (13)
Other	57 (16)	68 (19)
Baseline HIV-1 RNA copies/mL		
<50,000	249 (70)	254 (70)
≥50,000	105 (30)	107 (30)
Baseline CD4+ cells/mm³		
<50	62 (18)	59 (16)
50 to <200	111 (31)	125 (35)
200 to <350	82 (23)	79 (22)
≥ 350	99 (28)	98 (27)

Week 48 outcomes (including outcomes by key baseline covariates) for SAILING are shown in Table 14.

Table 14 Virologic Outcomes of SAILING at 48 Weeks (Snapshot algorithm)

	SAILING	
	TIVICAY 50 mg QD + BR N=354§ n/N (%)	ISENTRESS 400 mg BID + BR N=361§ n/N (%)
HIV-1 RNA <50 copies/mL	251/354 (71)	230/361 (64)
Adjusted Treatment Difference‡	7.4% (95% CI: 0.7%, 14.2%), p=0.030	
Virologic non-response†	71/354 (20)	100/361 (28)
No virologic data	32/354 (9)	31/361 (9)
<u>Reasons</u>		
Discontinued study/study drug due to adverse event or death‡	9 (3)	13 (4)
Discontinued study/study drug for other reasons§	16 (5)	14 (4)
Missing data during window but on study	7 (2)	4 (1)
HIV-1 RNA <50 copies/mL by baseline covariates		
Baseline Plasma Viral Load (copies/mL)		
≤50,000 copies/mL	186 / 249 (75)	180 / 254 (71)
>50,000 copies/mL	65 / 105 (62)	50 / 107 (47)
Baseline CD4+ (cells/ mm³)		
<50	33 / 62 (53)	30 / 59 (51)
50 to <200	77 / 111 (69)	76 / 125 (61)
200 to <350	64 / 82 (78)	53 / 79 (67)
≥350	77 / 99 (78)	71 / 98 (73)
Background Regimen		
Phenotypic Susceptibility Score * < 2	70 / 104 (67)	61 / 94 (65)
Phenotypic Susceptibility Score * = 2	181 / 250 (72)	169 / 267 (63)
Genotypic Susceptibility Score * < 2	155 / 216 (72)	129 / 192 (67)
Genotypic Susceptibility Score * = 2	96 / 138 (70)	101 / 169 (60)
No darunavir use	143 / 214 (67)	126 / 209 (60)
Darunavir use with primary PI substitutions	58 / 68 (85)	50 / 75 (67)
Darunavir use without primary PI substitutions	50 / 72 (69)	54 / 77 (70)
Gender		
Male	172 / 247 (70)	156 / 238 (66)
Female	79 / 107 (74)	74 / 123 (60)
Race		
White	133 / 178 (75)	125 / 175 (71)
African-American/African Heritage/Other	118 / 175 (67)	105 / 185 (57)
Age (years)		
<50	196 / 269 (73)	172 / 277 (62)
≥50	55 / 85 (65)	58 / 84 (69)
HIV sub type		
Clade B	173 / 241 (72)	159 / 246 (65)
Clade C	34 / 55 (62)	29 / 48 (60)
Other†	43 / 57 (75)	42 / 67 (63)
‡Adjusted for pre-specified stratification factors		
§ 4 patients were excluded from the efficacy analysis due to data integrity at one study site		
*The Phenotypic Susceptibility Score (PSS) and the Genotypic Susceptibility Score (GSS) were defined as the total number of ARTs in BR to which a subject's viral isolate showed susceptibility at baseline based upon phenotypic or genotypic resistance tests. Background regimen was restricted to ≤2 ARTs with at least one fully active agent, however, n=11 PSS 0, n=2 PSS 3.		

†Other clades included: Complex (n = 42), F1 (n = 32), A1 (n = 18), BF (n = 14), all others n = <10.
Notes: BR = background regimen, DTG = dolutegravir, RAL = raltegravir; N = Number of patients in each treatment group

At Week 48, virologic suppression (HIV-1 RNA < 50 copies/mL) in the dolutegravir arm (71%) was statistically significantly greater than the raltegravir arm (64%), (p=0.030) (see Table 14). Virologic suppression (HIV-1 RNA < 50 copies/mL) treatment differences were comparable across the baseline characteristics of gender, race, and HIV sub type.

The median changes in CD4+ T cell count from baseline were 144.0 cells/mm³ in the group receiving TIVICAY and 137.0 cells/mm³ for the ISENTRESS group.

Statistically significantly fewer patients failed therapy with treatment-emergent resistance in the IN gene on TIVICAY (4/354, 1%) than on ISENTRESS (17/361, 5%), p=0.003.

Integrase Inhibitor-Resistant Patients

VIKING-3 examined the effect of dolutegravir 50 mg twice daily over 7 days of functional monotherapy, followed by optimized background therapy and continued dolutegravir twice daily treatment.

In the multicentre, open-label, single arm VIKING-3 study (ING112574), 183 HIV-1-infected, treatment-experienced adults with virological failure and current or historical evidence of raltegravir and/or elvitegravir resistance received TIVICAY 50 mg twice daily with the current failing background regimen for 7 days, and then received TIVICAY with optimized background therapy from Day 8. Of the 183 patients enrolled, 133 showed INSTI-resistance (genotypic or phenotypic) at Screening and 50 had only historical evidence of resistance (and not at Screening). Table 15 shows baseline characteristics of patients in the VIKING-3 trial.

Table 15 Baseline Characteristics for all 183 patients enrolled that reached Week 24 (VIKING-3)

Demographic Characteristics	ITT-E
	TIVICAY 50 mg BID N=183 n (%)
Age (years)	
Median (Range)	48 (19-67)
Sex	
Female	42 (23)
Male	141 (77)
Race	
African American/African heritage	49 (27)
American Indian or Alaska native & White	1 (<1)
White	130 (71)
CDC Classification	
A: Asymptomatic or lymphadenopathy or acute HIV	44 (24)
B: Symptomatic, not AIDS	37 (20)
C: AIDS	102 (56)
Hepatitis B and/or C co-infection	
B only	10 (5)
C only	26 (14)
B and C	2 (1)
Baseline CD4+ cell counts cells/mm³	
Median CD4+ (range)	140.0 (19, 1100)
Prior Antiretroviral Therapy (ART)	
Etravirine	103 (56)
Darunavir-ritonavir	133 (73)
Enfuvirtide	89 (49)
Maraviroc	58 (32)
Median Number of prior ART (range)	14 (3-22)
Median Duration (years) of prior ART (range)	14 (4 months, 27 years)
Number (%) of Major ART Associated Mutations at Baseline	
≥2 NRTI	145 (79)
≥1 NNRTI	137 (75)
≥2 PI	129 (70)
Prevalence of CCR5 and/or CXCR4 Tropism at Baseline	
CCR5	61 (33)
Non-CCR5	113 (62)

Mean reduction from baseline in HIV RNA at Day 8 (primary endpoint) was 1.4 log₁₀ (95% CI 1.3 – 1.5 log₁₀, p < 0.001). More than 90% of subjects achieved full response (>1 log₁₀ c/mL decline or <50 c/mL plasma HIV-1 RNA) at Day 8 in the group of subjects without detectable Q148 primary mutations. In subjects with Q148 mutations, virologic response at Day 8 decreased with increasing number of secondary mutations (i.e. viral response rate was dropped to 71% and to 45% in Q148 plus 1 or ≥ 2 secondary substitutions, respectively).

After the monotherapy phase, patients' background regimens were optimized when possible. Week 24 and Week 48 virologic response and outcomes for VIKING-3 are shown in Table 16.

Table 16 Virologic Outcomes of VIKING-3 at Week 24 and Week 48 (Snapshot Algorithm)

	Week 24	Week 48
	TIVICAY 50 mg BID + OBT (N = 183)	TIVICAY 50 mg BID + OBT (N = 183)
HIV-1 RNA <50 copies/mL	126 (69%)	116 (63%)
Virologic non-response	50 (27%)	58 (32%)
No virologic data		
Reasons		
Discontinued study/study drug due to adverse event or death	5 (3%)	5 (3%)
Discontinued study/study drug for other reasons§	2 (1%)	4 (2%)
Missing data during window but on study	0 (0%)	0 (0%)
Proportion (%) with HIV-1 RNA < 50 c/mL by Baseline Category		
Gender		
Male	96/141 (68)	89/141 (63)
Female	30/42 (71)	27/42 (64)
Race		
White	91/130 (70)	82/130 (63)
African-American/African Heritage/Other	35/53 (66)	34/53 (64)
Median change from baseline in CD4+ cell count (range) in cells/mm³	61.0 (20.0, 130.0)	110.0 (40.0, 190.0)

Of the 183 patients who completed 24 weeks on study or discontinued before data cut-off, 126 (69%) had < 50 copies/mL RNA at Week 24 (FDA Snapshot algorithm). Patients harbouring virus with Q148H/K/R with 2 or more additional Q148-associated secondary mutations (L74I, E138A/K/T, or G140A/C/S) had a marked lower response at Week 24. Background overall susceptibility score (OSS) was not associated with Week 24 response.

Table 17 Virologic Response (HIV-1 RNA <50 copies/mL) by Derived Integrase-Resistance Substitution Group at Week 24 and Week 48 (Intent-to-Treat Exposed Population: Snapshot Algorithm)

Derived Integrase-Resistance Substitution Group	TIVICAY 50 mg BID (N = 183) Week 24	TIVICAY 50 mg BID (N = 183) Week 48
No Q148H/K/R substitution ^a	100/126 (79%)	90/126 (71%)
Q148 + 1 secondary substitution ^b	21/36 (58%)	20/36 (56%)
Q148 + ≥2 secondary substitutions ^b	5/21 (24%)	6/21 (29%)

^a N155H, Y143C/H/R, T66A, E92Q, or historical resistant evidence only.

^b Includes key secondary substitutions G140A/C/S, E138A/K/T, L74I.

The response rate at Week 48 was sustained with 116/183 (63%) patients having HIV-1 RNA <50 copies/mL (Snapshot algorithm). Response was also sustained through Week 48 in patients harbouring virus with Q148 with additional Q148-associated secondary mutations (see Table 17). Background overall susceptibility score (OSS) was not associated with Week 48 response.

Pediatric

In the ongoing Phase I/II 48-week multicentre, non-comparative, open-label study (IMPAACT P1093/ING112578), the pharmacokinetic parameters, safety, tolerability and efficacy of dolutegravir were evaluated in combination regimens in HIV-1-infected treatment-naïve or treatment experienced INSTI-naïve infants, children and adolescents. Subjects were stratified by age into cohorts, enrolling adolescents first (Cohort I: aged 12 to <18 years) and then younger children (Cohort IIA: aged 6 to <12 years). All subjects received the recommended weight-based dose of TIVICAY (see **DOSAGE AND ADMINISTRATION, Dosing Considerations, Pediatric Patients**).

These 46 patients had a mean age of 12 years (range: 6 to 17), were 54% female, and 52% black. At baseline, mean plasma HIV-1 RNA was 4.6 log₁₀ copies/mL, median CD4+ cell count was 639 cells/mm³ (range: 9 to 1700), and median CD4% was 23% (range: 1% to 44%). Overall, 39% had baseline plasma HIV-1 RNA ≥ 50,000 copies/mL and 33% had a CDC HIV clinical classification of category C. Most patients had previously used at least 1 NNRTI (50%) or 1 PI (70%). Week 24 and 48 outcomes for IMPAACT P1093/ING112578 are shown in Table 18.

Table 18 Virologic (Snapshot algorithm) and Immunologic Activity of Treatment for Subjects 6 Years and Older in IMPAACT P1093/ING112578

	Dolutegravir ~ 1 mg/kg once daily + OBT	
	Cohort I (12 to <18 years) (n = 23)	Cohort IIA (6 to < 12 years) (n = 23)
HIV-1-RNA < 50 copies/ml at 24 weeks	16 (70%)	14 (61%)
HIV-1-RNA < 50 copies/ml at 48 weeks, n (%)	14 (61%)	- ^a
HIV-1-RNA < 400 copies/ml at 24 weeks, n (%)	19 (83%)	18 (78%)
HIV-1-RNA < 400 copies/ml at 48 weeks, n (%)	17 (74%)	- ^a
Virologic non-response	6	3
CD4+ Cell Count		
Median Change from Baseline, cells/mm ³	84 ^b	209 ^c
Median Percent Change from Baseline	5 % ^a	8 % ^b

^a Data not yet available

^b 22 subjects contributed Week 48 CD4+ cell count data

^c 21 subjects contributed Week 24 CD4+ cell count data

Virologic outcomes were also evaluated based on body weight. Across both cohorts, virologic suppression (HIV-1 RNA less than 50 copies per mL) at Week 24 was achieved in 75% (18/24) of subjects weighing at least 40 kg, 55% (6/11) of subjects in the 30-to-less-than-40-kg weight-band, 50% (4/8) of subjects in the 20-to-less-than-30-kg weight-band, and 67% (2/3) of subjects in the 15-to-less-than-20-kg weight-band. At Week 48, 63% (12/19) of the subjects in Cohort I weighing at least 40 kg were virologically suppressed.

The median CD4+ cell count increase from baseline to Week 48 was 84 cells per mm³ in Cohort I. For Cohort IIA, the median CD4+ cell count increase from baseline to Week 24 was 209 cells per mm³.

DETAILED PHARMACOLOGY

Microbiology

Antiviral Activity in cell culture

Dolutegravir exhibited antiviral activity against laboratory strains of wild-type HIV-1 with mean EC₅₀ values of 0.51 nM to 2.1 nM in peripheral blood mononuclear cells (PBMCs) and MT-4 cells.

In a viral integrase susceptibility assay using the integrase coding region from 13 clinically diverse clade B isolates, dolutegravir demonstrated antiviral potency similar to laboratory strains, with a mean EC₅₀ of 0.52 nM. When tested in PBMC assays against a panel consisting of 24 HIV-1 clinical isolates [group M (clade A, B, C, D, E, F and G) and group O] and 3 HIV-2 clinical isolates, the geometric mean EC₅₀ was 0.20 nM (0.02 to 2.14 nM) for HIV-1, while the geometric mean EC₅₀ was 0.18 nM (0.09 to 0.61 nM) for HIV-2 isolates.

Antiviral Activity in combination with other antiviral agents

The following drugs were not antagonistic with dolutegravir in *in vitro* assessments conducted in checkerboard format: stavudine, abacavir, efavirenz, nevirapine, lopinavir, amprenavir, enfuvirtide, maraviroc, adefovir and raltegravir. In addition, the anti-HCV drug ribavirin had no apparent effect on dolutegravir activity.

Effect of Human Serum and Serum Proteins

In vitro studies suggested a 75-fold shift in EC₅₀ of dolutegravir in the presence of 100% human serum (by method of extrapolation), and the protein adjusted EC₉₀ (PA-IC₉₀) in PBMCs was estimated to be 0.064 µg/mL. Dolutegravir trough concentration for a single 50 mg dose in integrase inhibitor naïve patients was 1.20 µg/mL, 19 times higher than the estimated PA-EC₉₀.

Resistance *in vitro*

Isolation from wild-type HIV-1: Viruses highly resistant to dolutegravir were not observed during the 112-day passage of strain IIIB, with a 4.1-fold maximum fold change (FC) observed for the passaged resistant virus populations with substitutions at the conserved IN positions S153Y and S153F.

Passage of the wild-type HIV-1 strain NL432 in the presence of dolutegravir selected for E92Q (passage population virus FC=3.1) and G193E (passage population virus FC=3.2) substitutions on Day 56. Additional passage of wild-type subtype B, C, and A/G viruses in the presence of dolutegravir selected for R263K, G118R, and S153T.

Anti-HIV Activity Against Resistant Strains: Reverse Transcriptase Inhibitor- and Protease Inhibitor-Resistant Strains: Dolutegravir demonstrated equivalent antiviral activity against 2 non-nucleoside (NN)-RTI-resistant, 3 nucleoside (N)-RTI-resistant, and 2 PI-resistant HIV-1 mutant clones (1 triple and 1 sextuple) compared to the wild-type strain.

Integrase Inhibitor-Resistant HIV-1 Strains: Sixty integrase inhibitor-resistant mutant HIV-1 viruses (28 with single substitutions and 32 with 2 or more substitutions) were produced from wild-type virus NL-432 using site-directed mutagenesis. Dolutegravir showed anti-HIV activity (susceptibility) with FC < 5 against 27 of 28 integrase inhibitor-resistant mutant viruses with single substitutions including T66A/I/K, E92Q/V, Y143C/H/R, Q148H/K/R, and N155H, while for raltegravir and elvitegravir there were 17/28 and 11/21 tested mutant viruses with FC < 5, respectively. In addition, of the 32 integrase inhibitor-resistant mutant viruses with 2 or more substitutions, 23 of 32 showed FC < 5 to dolutegravir compared with FC < 5 for 4 of 32 for raltegravir and FC < 5 for 2 of 25 tested for elvitegravir.

Integrase Inhibitor-Resistant HIV-2 Strains: Site-directed mutant HIV-2 viruses were constructed based on patients infected with HIV-2 and treated with raltegravir who showed virologic failure (n=6). Overall the HIV-2 FCs observed were similar to HIV-1 FCs observed for similar pathway mutations. Dolutegravir FC was <5 against 4 HIV-2 viruses (S163D, G140A/Q148R, A153G/N155H/S163G and E92Q/T97A/N155H/S163D); for E92Q/N155H, dolutegravir FC was 8.5, and for G140S/Q148R, dolutegravir FC was 17. Dolutegravir, raltegravir and elvitegravir all had had the same activity against site-directed mutant HIV-2 with S163D as wild-type, and for the remaining mutant HIV-2 virus raltegravir FC ranges were 6.4 to 420 and elvitegravir FC ranges were 22 to 640.

Clinical Isolates From Raltegravir Treatment Virologic Failure Patients: Thirty clinical isolate samples with genotypic and phenotypic resistance to raltegravir (median FC > 81) were examined for susceptibility to dolutegravir (median FC 1.5) using the Monogram Biosciences PhenoSense assay. The median FC to dolutegravir for isolates containing changes at G140S + Q148H was 3.75; G140S + Q148R was 13.3; T97A + Y143R was 1.05 and N155H was 1.37.

Seven hundred and five raltegravir-resistant isolates (based on RAL FC > 1.5) from raltegravir-experienced patients were analyzed for susceptibility to dolutegravir using the Monogram Biosciences PhenoSense assay. Dolutegravir has a less than or equal to 10 FC against 93.9% of the 705 clinical isolates. Sixteen of 184 isolates with Q148+1 IN mutation and 25 of 92 isolates with Q148 +_≥ 2 IN mutations had dolutegravir FC>10.

Resistance *in vivo*: integrase inhibitor-naïve patients (ART-naïve and -experienced)

No INSTI-resistant mutations or treatment-emergent resistance to the NRTI backbone therapy were isolated with dolutegravir 50 mg once daily in treatment-naïve studies (SPRING-2, and/or SINGLE studies). In the SAILING study for treatment-experienced (and integrase-naïve) patients (n=354 in the dolutegravir arm), treatment-emergent integrase substitutions were observed at Week 48 in 4 of 17 subjects receiving dolutegravir with virologic failure. Of these four, 2 patients had a unique R263K integrase substitution, with a maximum FC of 1.93, 1 patient had a polymorphic V151V/I integrase substitution, with maximum FC of 0.92, and 1 subject had pre-existing integrase mutations and is assumed to have been integrase-experienced or infected with integrase-resistant virus by transmission. Treatment emergent N155H and T97A integrase substitutions along with dolutegravir FC of 2.4 and RAL FC of 113 were observed at Week 84 for one patient who was non-compliant with IP and thus a protocol deviator. Significantly fewer subjects failed therapy at Week 48 with treatment-emergent resistance in the integrase gene on TIVICAY (4/354 [1.0%]), than on raltegravir (17/361 [5%]). The treatment difference was statistically significant in favour of dolutegravir (p=0.003) based on a pre-specified analysis of this key secondary endpoint (see **CLINICAL TRIALS**).

Resistance *in vivo*: integrase inhibitor-resistant patients

The VIKING-3 study examined dolutegravir (plus optimized background therapy) in patients with pre-existing INSTI-resistance. Thirty six patients (36/183) experienced protocol defined virologic failure through to Week 24. Of these, 32 had paired baseline and PDVF resistance data for analysis and 17/32 (53%) had treatment emergent mutations. Treatment-emergent mutations or mixtures of mutations observed were L74L/M (n=1), E92Q (n=2), T97A (n=9), E138K/A/T (n=8), G140S (n=2), Y143H (n=1), S147G (n=1), Q148H/K/R (n=4), N155H (n=1) and E157E/Q (n=1). Fourteen of the 17 patients with virus exhibiting treatment-emergent mutations harboured Q148 pathway virus present at baseline or historically. Five further patients experienced PDVF between Weeks 24 and 48, and 2 of these 5 had treatment-emergent mutations. Treatment-emergent mutations or mixtures of mutations observed were L74I (n=1), N155H (n=2). Post Week 48, 4 additional subjects experienced PDVF at Week 60 (n=2), Week 72 (n=1) and Week 84 (n=1). Three of these 4 subjects had treatment-emergent mutations. Treatment-emergent mutations or mixtures of mutations observed were T97A (n=1), E138K (n=1), Q148H (n=2), G140S (n=2), N155H (n=1), L74M/V (n=1).

Pharmacokinetics

Drug interaction studies were performed with TIVICAY and other drugs likely to be co-administered or commonly used as probes for pharmacokinetic interactions. As there is low propensity of dolutegravir to alter the pharmacokinetics of other drugs dependent on hepatic metabolism (Table 19), the primary focus of these drug interaction studies was to evaluate the effect of co-administered drug on dolutegravir (Table 20).

Dosing recommendations as a result of established and other potentially significant drug-drug interactions with TIVICAY are provided in Table 6.

Table 19 Summary of Effect of Dolutegravir on the Pharmacokinetics of Co-administered Drugs

Co-administered Drug(s) and Dose(s)	Dose of TIVICAY	n	Geometric Mean Ratio (90% CI) of Pharmacokinetic Parameters of Co-administered Drug With/Without Dolutegravir No Effect = 1.00		
			C _t or C ₂₄	AUC	C _{max}
Ethinyl estradiol 0.035 mg	50 mg twice daily	15	1.02 (0.93, 1.11)	1.03 (0.96, 1.11)	0.99 (0.91, 1.08)
Methadone 20 to 150 mg	50 mg twice daily	12	0.99 (0.91, 1.07)	0.98 (0.91, 1.06)	1.00 (0.94, 1.06)
Midazolam 3 mg	25 mg once daily	10	–	0.95 (0.79, 1.15)	–
Norgestimate 0.25 mg	50 mg twice daily	15	0.93 (0.85, 1.03)	0.98 (0.91, 1.04)	0.89 (0.82, 0.97)
Rilpivirine 25 mg once daily	50 mg once daily	16	1.21 (1.07, 1.38)	1.06 (0.98, 1.16)	1.10 (0.99, 1.22)
Tenofovir disoproxil fumarate 300 mg once daily	50 mg once daily	16	1.19 (1.04, 1.35)	1.12 (1.01, 1.24)	1.09 (0.97, 1.23)
Metformin 500 mg twice daily	50 mg once daily	14	–	1.79 (1.65, 1.93)	1.66 (1.53, 1.81)
Metformin 500 mg twice daily	50 mg twice daily	14	–	2.45 (2.25, 2.66)	2.11 (1.91, 2.33)

Table 20 Summary of Effect of Co-administered Drugs on the Pharmacokinetics of Dolutegravir

Co-administered Drug(s) and Dose(s)	Dose of TIVICAY	n	Geometric Mean Ratio (90% CI) of Dolutegravir Pharmacokinetic Parameters With/Without Co- administered Drugs No Effect = 1.00		
			C _t or C ₂₄	AUC	C _{max}
Atazanavir 400 mg once daily	30 mg once daily	12	2.80 (2.52, 3.11)	1.91 (1.80, 2.03)	1.50 (1.40, 1.59)
Atazanavir/ritonavir 300/100 mg once daily	30 mg once daily	12	2.21 (1.97, 2.47)	1.62 (1.50, 1.74)	1.34 (1.25, 1.42)
Tenofovir 300 mg once daily	50 mg once daily	15	0.92 (0.82, 1.04)	1.01 (0.91, 1.11)	0.97 (0.87, 1.08)

Co-administered Drug(s) and Dose(s)	Dose of TIVICAY	n	Geometric Mean Ratio (90% CI) of Dolutegravir Pharmacokinetic Parameters With/Without Co- administered Drugs No Effect = 1.00		
			C _τ or C ₂₄	AUC	C _{max}
Darunavir/ritonavir 600/100 mg twice daily	30 mg once daily	15	0.62 (0.56, 0.69)	0.78 (0.72, 0.85)	0.89 (0.83, 0.97)
Efavirenz 600 mg once daily	50 mg once daily	12	0.25 (0.18, 0.34)	0.43 (0.35, 0.54)	0.61 (0.51, 0.73)
Etravirine 200 mg twice daily	50 mg once daily	15	0.12 (0.09, 0.16)	0.29 (0.26, 0.34)	0.48 (0.43, 0.54)
Etravirine + darunavir/ritonavir 200 mg + 600/100 mg twice daily	50 mg once daily	9	0.63 (0.52, 0.76)	0.75 (0.69, 0.81)	0.88 (0.78, 1.00)
Etravirine + lopinavir/ritonavir 200 mg + 400/100 mg twice daily	50 mg once daily	8	1.28 (1.13, 1.45)	1.11 (1.02, 1.20)	1.07 (1.02, 1.13)
Fosamprenavir/ritonavir 700 mg + 100 mg twice daily	50 mg once daily	12	0.51 (0.41, 0.63)	0.65 (0.54, 0.78)	0.76 (0.63, 0.92)
Lopinavir/ritonavir 400/100 mg twice daily	30 mg once daily	15	0.94 (0.85, 1.05)	0.97 (0.91, 1.04)	1.00 (0.94, 1.07)
Maalox	50 mg single dose	16	0.26 (0.21, 0.31)	0.26 (0.22, 0.32)	0.28 (0.23, 0.33)
Maalox 2 hrs after dolutegravir	50 mg single dose	16	0.70 (0.58, 0.85)	0.74 (0.62, 0.90)	0.82 (0.69, 0.98)
Calcium Carbonate 1200 mg simultaneous administration (fasted)	50 mg single dose	12	0.61 (0.47, 0.80)	0.61 (0.47, 0.80)	0.63 (0.50, 0.81)
Calcium Carbonate 1200 mg simultaneous administration (fed)	50 mg single dose	11	1.08 (0.81, 1.42)	1.09 (0.84, 1.43)	1.07 (0.83, 1.38)
Calcium Carbonate 1200 mg 2 hrs after dolutegravir	50 mg single dose	11	0.90 (0.68, 1.19)	0.94 (0.72, 1.23)	1.00 (0.78, 1.29)
Ferrous Fumarate 324 mg simultaneous administration (fasted)	50 mg single dose	11	0.44 (0.36, 0.54)	0.46 (0.38, 0.56)	0.43 (0.35, 0.52)
Ferrous Fumarate 324 mg simultaneous administration (fed)	50 mg single dose	11	1.00 (0.81, 1.23)	0.98 (0.81, 1.20)	1.03 (0.84, 1.26)

Co-administered Drug(s) and Dose(s)	Dose of TIVICAY	n	Geometric Mean Ratio (90% CI) of Dolutegravir Pharmacokinetic Parameters With/Without Co- administered Drugs No Effect = 1.00		
			C _r or C ₂₄	AUC	C _{max}
Ferrous Fumarate 324 mg 2 hrs after dolutegravir	50 mg single dose	10	0.92 (0.74, 1.13)	0.95 (0.77, 1.15)	0.99 (0.81, 1.21)
Multivitamin One tablet once daily	50 mg single dose	16	0.68 (0.56, 0.82)	0.67 (0.55, 0.81)	0.65 (0.54, 0.77)
Omeprazole 40 mg once daily	50 mg single dose	12	0.95 (0.75, 1.21)	0.97 (0.78, 1.20)	0.92 (0.75, 1.11)
Prednisone 60 mg once daily with taper	50 mg once daily	12	1.17 (1.06, 1.28)	1.11 (1.03, 1.20)	1.06 (0.99, 1.14)
Rifampin ^a 600 mg once daily	50 mg twice daily ^a	11	0.28 (0.23, 0.34)	0.46 (0.38, 0.55)	0.57 (0.49, 0.65)
Rifampin ^b 600 mg once daily	50 mg twice daily ^b	11	1.22 (1.01, 1.48)	1.33 (1.15, 1.53)	1.18 (1.03, 1.37)
Rifabutin 300 mg once daily	50 mg once daily	9	0.70 (0.57, 0.87)	0.95 (0.82, 1.10)	1.16 (0.98, 1.37)
Rilpivirine 25 mg once daily	50 mg once daily	16	1.22 (1.15, 1.30)	1.12 (1.05, 1.19)	1.13 (1.06, 1.21)
Tipranavir/ritonavir 500/200 mg twice daily	50 mg once daily	14	0.24 (0.21, 0.27)	0.41 (0.38, 0.44)	0.54 (0.50, 0.57)
Telaprevir 750 mg every 8 hours	50 mg once daily	15	1.37 (1.29, 1.45)	1.25 (1.20, 1.31)	1.18 (1.11, 1.26)
Boceprevir 800 mg every 8 hours	50 mg once daily	13	1.08 (0.91, 1.28)	1.07 (0.95, 1.20)	1.05 (0.96, 1.15)
Carbamazepine 300 mg twice daily	50 mg once daily	14	0.27 (0.24, 0.31)	0.51 (0.48, 0.55)	0.67 (0.61, 0.73)
Daclatasvir 60 mg once daily	50 mg once daily	12	1.06 (0.88, 1.29)	0.98 (0.83, 1.15)	1.03 (0.84, 1.25)

^a Comparison is rifampin taken with dolutegravir 50 mg twice daily compared with dolutegravir 50 mg twice daily.

^b Comparison is rifampin taken with dolutegravir 50 mg twice daily compared with dolutegravir 50 mg once daily.

TOXICOLOGY

Carcinogenesis/mutagenesis

Dolutegravir was not mutagenic or clastogenic using *in vitro* tests in bacteria and cultured mammalian cells, and an *in vivo* rodent micronucleus assay. Dolutegravir was not carcinogenic in long-term studies in the mouse and rat at exposures ~14 and ~12 times, respectively, above the 50 mg twice-daily human clinical exposure based on AUC.

Reproductive Toxicology

Fertility: There are no data on the effects of dolutegravir on human male or female fertility. Animal studies indicate no effects of dolutegravir on male or female fertility. Dolutegravir did not affect male or female fertility in rats at doses up to 1000 mg/kg/day, the highest dose tested (~24 times the 50 mg twice-daily human clinical exposure based on AUC).

Pregnancy: Oral administration of dolutegravir to pregnant rats at doses up to 1000 mg/kg daily from Days 6 to 17 of gestation did not elicit maternal toxicity, developmental toxicity or teratogenicity (~27 times the 50 mg twice-daily human clinical exposure based on AUC).

Oral administration of dolutegravir to pregnant rabbits at doses up to 1000 mg/kg daily from Days 6 to 18 of gestation did not elicit developmental toxicity or teratogenicity (0.4 times the 50 mg twice-daily human clinical exposure based on AUC). In rabbits, maternal toxicity (decreased food consumption, scant/no faeces/urine, suppressed body weight gain) was observed at 1000 mg/kg (0.4 times the 50 mg twice-daily human clinical exposure based on AUC).

In a non-clinical distribution study in animals, dolutegravir was shown to cross the placenta.

Animal toxicology and/or pharmacology

The effect of prolonged daily treatment with high doses of dolutegravir has been evaluated in repeat oral dose toxicity studies in rats (up to 26 weeks) and in monkeys (up to 38 weeks). The primary effect of dolutegravir was gastrointestinal intolerance or irritation in rats and monkeys at doses that produce systemic exposures approximately 21 and 0.8 times the 50 mg twice-daily human clinical exposure based on AUC, respectively. Because gastrointestinal (GI) intolerance is considered to be due to local drug administration, mg/kg or mg/m² metrics are appropriate determinates of safety cover for this toxicity. GI intolerance in monkeys occurred at 15 times the human mg/kg equivalent dose (based on 50 kg human), and 5 times the human mg/m² equivalent dose for a clinical dose of 50 mg twice-daily. Dolutegravir was slightly to mildly irritating to skin and eyes in the rabbit.

REFERENCES

1. Boyd M. Dolutegravir - a promising antiretroviral in development. *Lancet Infect Dis*. 2012 Feb; 12(2):90-1.
2. Cahn P, Pozniak A, Mingrone H, et al. Dolutegravir versus raltegravir in antiretroviral-experienced, integrase-inhibitor-naïve adults with HIV: Week 48 results from the randomised, double-blind, non-inferiority SAILING study. *Lancet*. 2013; 382(9893):700-8.
3. Castagna A, Maggiolo F, Penco G, et al. Dolutegravir in antiretroviral-experienced patients with raltegravir – and/or elvitegravir-resistance HIV-1: 24-week results of the phase III VIKING-3 Study. *J Infect Dis*. 2014.
4. Castellino S, Moss L, Wagner D, et al. Metabolism, excretion, and mass balance of the HIV-1 integrase dolutegravir in humans. *Antimicrob Agents Chemother*. 2013; 57(8):3536-3546.
5. Chen S, Min SS, Peppercorn A, et al. Effect of a single supratherapeutic dose of dolutegravir (S/GSK1349572) on cardiac conduction. *Pharmacotherapy*. 2012; 32(4):333-339.
6. Chen S, St Jean P, Borland J, et al. Evaluation of the effect of UGT1A1 polymorphisms on dolutegravir pharmacokinetics. *Pharmacogenomics*. 2014; 15(1):9-16.
7. Dooley KE, Sayre P, Borland J, et al. Safety, tolerability, and pharmacokinetics of the HIV integrase inhibitor dolutegravir given twice daily with rifampin or once daily with rifabutin: results of a phase 1 study among healthy subjects. *J Acquir Immune Defic Syndr*. 2013 Jan; 62(1):21–27.
8. Eron JJ, Clotet B, Durant J, et al. Safety and Efficacy of Dolutegravir (DTG) in HIV-1 Treatment-Experienced Subjects With Raltegravir-Resistant Virus: 24-Week Results of the VIKING Study. *Journal of Infectious Diseases*. 2013 Mar; 207(5):740–748.
9. Ford S, Gould E, Chen S, et al. Lack of pharmacokinetic interaction between rilpivirine and integrase inhibitors dolutegravir and GSK1265744. *Antimicrob Agents Chemother*. 2013; 57(11):5472-5477.
10. Hightower KE, Wang R, Deanda F, et al. Dolutegravir (S/GSK1349572) Exhibits Significantly Slower Dissociation than Raltegravir and Elvitegravir from Wild-Type and Integrase Inhibitor-Resistant HIV-1 Integrase-DNA Complexes. *Antimicrobial Agents and Chemotherapy*. 2011 Oct; 55(10):4552–4559.

11. Mesplède T, Quashie PK, Osman N, et al. Viral fitness cost prevents HIV-1 from evading dolutegravir drug pressure. *Retrovirology*. 2013 Feb 22; 10:22.
12. Koteff J, Borland J, Chen S, et al. A phase 1 study to evaluate dolutegravir's effect on renal function via measurement of iohexol and para-aminohippurate clearance in healthy subjects. *Br J Clin Pharmacol*. 2013 Apr; 75(4):990–996.
13. Quashie PK, Mesplede T, Han YS, et al. Characterization of the R263K mutation in HIV-1 integrase that confers low-level resistance to the second-generation integrase strand transfer inhibitor dolutegravir. *J Virol*. 2012 Mar; 86(5):2696-705.
14. Raffi F, Jaeger H, Quiros-Roldan E, et al. Once-daily dolutegravir versus twice-daily raltegravir in antiretroviral-naïve adults with HIV-1 infection (SPRING-2 study): 96-week results from a randomised, double-blind, non-inferiority trial. *Lancet Infect Dis*. 2013; 13(11):927-935.
15. Raffi F, Rachlis A, Stellbrink HJ, et al. Once-daily dolutegravir versus raltegravir in antiretroviral naïve adults with HIV-1 infection: 48-week results from the randomised, double-blind, non-inferiority SPRING-2 study. *Lancet*. 2013 Mar; 381(9868):735–743.
16. Reese MJ, Savina PM, Generaux GT, et al. In vitro investigations into the roles of drug transporters and metabolizing enzymes in the disposition and drug interactions of dolutegravir, a HIV integrase inhibitor. *Drug Metab Dispos*. 2013 Feb; 41(2):353-361.
17. Rhodes MC, Laffan S, Genell C, et al. Assessing a theoretical risk of dolutegravir-induced developmental immunotoxicity in juvenile rats. *Toxicol Sci*. 2012 Nov; 130(1):70-81.
18. Saladini F, Meini G, Bianco C, et al. Prevalence of HIV-1 integrase mutations related to resistance to dolutegravir in raltegravir naïve and pretreated patients. *Clin Microbiol Infect*. 2012 Oct; 18(10):E428-30.
19. Song I, Borland J, Chen S, et al. Effect of food on the pharmacokinetics of the integrase inhibitor dolutegravir. *Antimicrob Agents Chemother*. 2012; 56(3):1627-1629.
20. Song I, Borland J, Chen S, et al. Effect of prednisone on the pharmacokinetics of the integrase inhibitor dolutegravir. *Antimicrob Agents Chemother*. 2013; 57(9):4394-4397.
21. Song I, Mark S, Chen S, et al. Dolutegravir does not affect methadone pharmacokinetics in opioids-dependent, HIV-seronegative subjects. *Drug Alcohol Depend*. 2013. 133(2):781-784.

22. Stellbrink H, Reynes J, Lazzarin A, et al. Dolutegravir in antiretroviral-naïve adults with HIV-1: 96-week results from a randomized dose-ranging study. *AIDS*. 2013; 27(11):1771-1778.
23. Underwood MR, Johns BA, Sato A, et al. The activity of the integrase inhibitor dolutegravir against HIV-1 variants isolated from raltegravir-treated adults. *J Acquir Immune Defic Syndr*. 2012; 61(3):297-301.
24. vanLunzen J, Maggiolo F, Arribas J, et al. Once daily dolutegravir (S/GSK1349572) in combination therapy in antiretroviral-naïve adults with HIV: planned interim 48-week results from SPRING-1, a dose-ranging, randomised, phase 2b trial. *Lancet Infect Dis*. 2012; 12(2):111-118.
25. Walmsley S, Antela A, Clumeck N, et al. Dolutegravir plus abacavir/lamivudine for the treatment of HIV-1 infection. *N Engl Med J*. 2013; 369(19):1807-1818.
26. Weller S, Borland J, Chen S, et al. Pharmacokinetics of dolutegravir in HIV-seronegative subjects with severe renal impairment. *Eur J Clin Pharmacol*. 2014; 70(1):29-35.

PART III: CONSUMER INFORMATION

**PrTIVICAY
Dolutegravir (as dolutegravir sodium)
10 mg, 25 mg and 50 mg tablets**

This leaflet is part III of a three-part "Product Monograph" published when TIVICAY was approved for sale in Canada and is designed specifically for Consumers. This leaflet is a summary and will not tell you everything about TIVICAY. Contact your doctor or pharmacist if you have any questions about the drug.

ABOUT THIS MEDICATION

What the medication is used for:

TIVICAY is a prescription oral tablet used for treatment of HIV-1 (Human Immunodeficiency Virus) infection in adults and children at least 6 years of age and weighing at least 15 kg.

TIVICAY is a type of anti-HIV medicine called an integrase inhibitor. HIV is the virus that causes AIDS (Acquired Immune Deficiency Syndrome).

TIVICAY is used in combination with other anti-retroviral medicines. To control your HIV infection, and to stop your illness from getting worse, you must keep taking all your medicines, unless your doctor tells you otherwise.

What it does:

TIVICAY interferes with viral replication, thereby helping to control HIV infection.

How does TIVICAY work?

TIVICAY blocks an enzyme which the virus (HIV) needs in order to make more virus. The enzyme that TIVICAY blocks is called HIV integrase.

When used with other anti-HIV medicines, TIVICAY may do two things:

1. It may reduce the amount of HIV in your blood. This is called your "viral load".
 - Reducing the amount of HIV in the blood may keep your immune system healthy.
 - This in turn, can help your immune system to fight infection.
2. It may also increase the number of white blood cells that help fight the virus (HIV).
 - physicians call them CD4 (T) cells

When it should not be used:

Do not take TIVICAY if you are allergic to dolutegravir or any of the ingredients in TIVICAY (see **What the important nonmedicinal ingredients are** for a complete list of ingredients in TIVICAY.)

Do not take TIVICAY if you are taking dofetilide to treat heart conditions, or fampridine (also known as dalfampridine) to treat multiple sclerosis.

What the medicinal ingredient is:

Each 10 mg, 25 mg and 50 mg tablet of TIVICAY contains 10 mg, 25 mg and 50 mg of dolutegravir, respectively, (as dolutegravir sodium).

What the important nonmedicinal ingredients are:

D-mannitol, microcrystalline cellulose, povidone K29/32, sodium starch glycolate, and sodium stearyl fumarate. The tablet film coating contains the inactive ingredients iron oxide yellow (25 mg and 50 mg tablets only), macrogol/PEG, polyvinyl alcohol-part hydrolyzed, talc, and titanium dioxide.

What dosage forms it comes in:

TIVICAY is available as film-coated 10, 25 and 50 mg tablets.

WARNINGS AND PRECAUTIONS

TIVICAY will not stop you from passing HIV to others, although this risk is lower if you take your HIV medicine as instructed by your healthcare professional. You should take steps to avoid this by:

- using condoms when you have oral or penetrative sex,
- not reusing or sharing needles, syringes, or other injection equipment.

BEFORE you use TIVICAY talk to your doctor or pharmacist if you:

- have liver problems, including hepatitis B or C;
- are pregnant or planning to become pregnant; do not take TIVICAY without speaking with your doctor. Your doctor will consider the benefit to you and the risk to your baby when taking TIVICAY while pregnant. If you take TIVICAY while you are pregnant, talk to your doctor about enrolling in the Antiretroviral Pregnancy Registry.
- could get pregnant. Use a reliable method of contraception to prevent pregnancy, while taking TIVICAY.
- taking TIVICAY at the time of becoming pregnant, or during the first 12 weeks of pregnancy, may increase the risk of a type of birth defect, called

neural tube defect, such as spina bifida (malformed spinal cord).

- are breastfeeding or plan to breastfeed. Where possible, women who are HIV positive should not breast feed, because HIV infection can pass into breast milk and harm your baby.
- It is not known if TIVICAY can pass into breast milk and harm your baby. Talk to your doctor immediately, if you are breastfeeding, or thinking about breastfeeding. Do not breastfeed while taking TIVICAY.
- have any other medical condition
- are taking any other medications (see Interactions with this medication)

Other special warnings

Serious liver problems including liver injury and liver failure have been seen in people taking medicines containing dolutegravir (see Serious Side Effects box). In some cases the liver injury has led to a liver transplant. While you are being treated with TIVICAY your doctor will monitor you closely for any signs of liver problems.

INTERACTIONS WITH THIS MEDICATION

Tell your healthcare provider about all prescription and non-prescription medications you are taking; including any vitamins, herbal supplements, and dietary supplements. Some drugs may interact with TIVICAY and can affect how TIVICAY works, or make it more likely that you will have side effects. These include:

- metformin, to treat diabetes
- medicines called antacids, to treat indigestion and heartburn. Do not take an antacid during the 6 hours before you take TIVICAY, or for at least 2 hours after you take it.
- calcium and iron supplements. Do not take a calcium or iron supplement during the 6 hours before you take TIVICAY, or for at least 2 hours after you take it. If you take food with your medicine, you can take a calcium or iron supplement at the same time as TIVICAY.
- etravirine, efavirenz, fosamprenavir/ritonavir, nevirapine or tipranavir/ritonavir, to treat HIV infection
- rifampin, to treat tuberculosis (TB) and other bacterial infections
- phenytoin and phenobarbital, to treat epilepsy
- oxcarbazepine and carbamazepine, to treat epilepsy and bipolar disorder
- St. John's wort, (*Hypericum perforatum*), a herbal remedy to treat depression

PROPER USE OF THIS MEDICATION

Always take TIVICAY exactly as your doctor has told you to. Check with your doctor or pharmacist if you're not sure. Do not change your dose or stop taking TIVICAY without talking with your doctor.

Usual dose:

Adults: The usual dose of TIVICAY is one 50 mg tablet, once a day.

For adults with HIV infection that is resistant to other HIV medicines similar to TIVICAY, the usual dose of TIVICAY is one 50 mg tablet, twice a day.

Your doctor will decide on the correct dose of TIVICAY for you.

Children at least 6 years of age and weighing at least 15 kg: Your doctor will decide on the correct dose of TIVICAY for your child, depending on the weight of the child.

Swallow the tablet with some liquid. TIVICAY can be taken with or without food.

Antacid medicines

Antacids, to treat indigestion and heartburn, can stop TIVICAY from being absorbed into your body and make it less effective.

Do not take an antacid during the 6 hours before you take TIVICAY, or for at least 2 hours after you take it. Other acid-lowering medicines like ranitidine and omeprazole can be taken at the same time as TIVICAY. Talk to your doctor for further advice on taking acid-lowering medicines with TIVICAY.

Calcium or iron supplements

Calcium or iron supplements can stop TIVICAY from being absorbed into your body and make it less effective.

Do not take a calcium or iron supplement during the 6 hours before you take TIVICAY, or for at least 2 hours after you take it. If you take food with TIVICAY, then you can take calcium and iron supplements at the same time as TIVICAY.

Be sure to keep a supply of your anti-HIV medicines:

- When your TIVICAY supply starts to run low, get more from your physician or pharmacy.
- Do not wait until your medicine runs out to get more.

Overdose:

If you take too many tablets of TIVICAY, contact your

doctor or pharmacist for advice. If possible, show them the TIVICAY pack.

In case of drug overdose, contact a health care practitioner, hospital emergency department or regional Poison Control Centre immediately, even if there are no symptoms.

Missed Dose:

If you miss a dose, take it as soon as you remember, but if your next dose is due within 4 hours, skip the dose you missed and take the next one at the usual time. Then continue your treatment as before. DO NOT take a double dose of your medicine to make up for a missed dose.

SIDE EFFECTS AND WHAT TO DO ABOUT THEM

The most common side effects of TIVICAY include:

- diarrhea
- headache
- trouble sleeping (insomnia)
- feeling sick (nausea)
- lack of energy (fatigue)

Other side effects include, rash, itching (pruritus), being sick (vomiting), stomach pain (abdominal pain), stomach (abdominal) discomfort, intestinal gas (flatulence), joint pain, muscle pain, weight gain, dizziness, abnormal dreams, depression (feelings of deep sadness and unworthiness), anxiety, and suicidal thoughts and behaviours (mainly in patients who have had depression or mental health problems before). If you have such feelings, talk to your doctor.

Side effects that may show up in blood tests include an increase in bilirubin (a substance produced by the liver), and/or an increase in the level of enzymes produced in the muscles (creatine phosphokinase) or an increase in a kidney function test result (creatinine).

Changes to your immune system (Immune Reconstitution Inflammatory Syndrome) can happen when you start taking HIV-1 medicines. Your immune system may get stronger and begin to fight infections that have been hidden in your body for a long time.

Autoimmune disorders (when the immune system attacks healthy body tissue), may also occur after you start taking medicines for HIV infection. Examples of this include: Grave's disease (which affects the thyroid gland), Guillain-Barré syndrome (which affects the nervous system), polymyositis (which affects the muscles), or autoimmune hepatitis (which affects the liver). Autoimmune disorders may occur many months after the start of treatment. Look for any other symptoms such as:

- high temperature (fever), redness, rash or swelling
- fatigue
- joint or muscle pain
- numbness, tingling, or weakness beginning in the hands and feet and moving up towards the trunk of the body
- palpitations (chest pain) or rapid heart rate
- yellowing of the skin or eyes
- anxiety and irritability accompanied by tremor of your hands or fingers
- muscle weakness in your hips, thighs, shoulders, upper arms and neck.

If you notice these or any symptoms of inflammation or infection, tell your doctor immediately.

Tell your doctor or pharmacist if any of the side effects mentioned becomes severe or troublesome, or if you notice any other side effects not listed in this leaflet.

SERIOUS SIDE EFFECTS, HOW OFTEN THEY HAPPEN AND WHAT TO DO ABOUT THEM				
Symptom / effect		Talk with your doctor or pharmacist		Stop taking drug and call your doctor or pharmacist
		Only if severe	In all cases	
Uncommon	<u>Hypersensitivity (allergic)</u> Skin rash, fever, lack of energy, swelling of the mouth or face causing difficulty in breathing, muscle or joint aches			✓
	<u>Liver problems (Hepatitis):</u> High liver blood test results, nausea/vomiting loss of appetite, pain, aching or tenderness on the right side below the ribs. If hepatitis is severe, the following may occur: yellowing of the skin or whites of the			✓

SERIOUS SIDE EFFECTS, HOW OFTEN THEY HAPPEN AND WHAT TO DO ABOUT THEM

Symptom / effect		Talk with your doctor or pharmacist		Stop taking drug and call your doctor or pharmacist
		Only if severe	In all cases	
	eyes, dark or tea coloured urine, pale coloured stools/ bowel movements.			
Rare	<u>Liver failure:</u> Extremely high liver blood test results, nausea/vomiting, loss of appetite, pain, aching or tenderness on the right side below the ribs, yellowing of the skin and the whites of the eyes, dark or tea coloured urine, pale coloured stools/bowel movements.			✓

This is not a complete list of side effects. For any unexpected effects while taking TIVICAY, contact your doctor or pharmacist.

HOW TO STORE IT

Store TIVICAY 10, 25 and 50 mg up to 30°C. Store TIVICAY 10 mg tablets in the original package (HDPE bottle) in order to protect from moisture. Keep the bottle tightly closed. Do not remove the silica gel desiccant

Keep out of reach and sight of young children.

REPORTING SUSPECTED SIDE EFFECTS

You can report any suspected adverse reactions associated with the use of health products to the Canada Vigilance Program by one of the following 3 ways:

- Report online at <https://www.canada.ca/en/health-canada/services/drugs-health-products/medeffect-canada/adverse-reaction-reporting.html>
- Call toll-free at 1-866-234-2345
- Complete a Canada Vigilance Reporting Form and:
 - Fax toll-free to 1-866-678-6789, or
 - Mail to: Canada Vigilance Program
Health Canada
Postal Locator 1908C
Ottawa, Ontario
K1A 0K9

Postage paid labels, Canada Vigilance Reporting Form and the adverse reaction reporting guidelines are available on the MedEffect™ Canada Web site at <https://www.canada.ca/en/health-canada/services/drugs-health-products/medeffect-canada/adverse-reaction-reporting.html>.

NOTE: Should you require information related to the management of side effects, contact your health professional. The Canada Vigilance Program does not provide medical advice.

MORE INFORMATION

This document plus the full product monograph, prepared for health professionals can be found at:

www.viivhealthcare.ca

or by contacting the sponsor, ViiV Healthcare ULC at:
245, boulevard Armand-Frappier
Laval, Quebec
H7V 4A7
1-877-393-8448

This leaflet was prepared by ViiV Healthcare ULC.

Last revised: January 31, 2020

© 2020 ViiV Healthcare group of companies

Trademarks are owned by or licensed to the ViiV Healthcare group of companies.

HIGHLIGHTS OF PRESCRIBING INFORMATION

These highlights do not include all the information needed to use TIVICAY safely and effectively. See full prescribing information for TIVICAY.

TIVICAY (dolutegravir) tablets, for oral use
TIVICAY PD (dolutegravir) tablets for oral suspension
Initial U.S. Approval: 2013

RECENT MAJOR CHANGES

Indications and Usage (1)	06/2020
Dosage and Administration (2)	06/2020
Warnings and Precautions, Embryo-Fetal Toxicity (5.3)	10/2019
Warnings and Precautions, Different Formulations Are Not Interchangeable (5.6)	06/2020

INDICATIONS AND USAGE

TIVICAY and TIVICAY PD are a human immunodeficiency virus type 1 (HIV-1) integrase strand transfer inhibitor (INSTI) indicated in combination with other antiretroviral agents for the treatment of HIV-1 infection in adults (treatment-naïve or -experienced) and in pediatric patients (treatment-naïve or -experienced but INSTI-naïve) aged at least 4 weeks and weighing at least 3 kg. (1)

TIVICAY is indicated in combination with rilpivirine as a complete regimen for the treatment of HIV-1 infection in adults to replace the current antiretroviral regimen in those who are virologically suppressed (HIV-1 RNA less than 50 copies per mL) on a stable antiretroviral regimen for at least 6 months with no history of treatment failure or known substitutions associated with resistance to either antiretroviral agent. (1)

DOSAGE AND ADMINISTRATION

- Pregnancy Testing: Perform pregnancy testing before initiation of dolutegravir in adolescents and adults of childbearing potential. (2.1, 5.3)
- May be taken without regard to food. (2.2, 2.6)

Adult Population	Recommended Dose
Treatment-naïve or treatment-experienced INSTI-naïve or virologically suppressed (HIV-1 RNA <50 copies per mL) adults switching to dolutegravir plus rilpivirine ^a (2.2)	50 mg once daily
Treatment-naïve or treatment-experienced INSTI-naïve when coadministered with certain UGT1A or CYP3A inducers (2.2, 7.2, 7.3)	50 mg twice daily
INSTI-experienced with certain INSTI-associated resistance substitutions or clinically suspected INSTI resistance ^b (2.2, 12.4)	50 mg twice daily

^aRilpivirine dose is 25 mg once daily for those switching to dolutegravir plus rilpivirine.

^bAlternative combinations that do not include metabolic inducers should be considered where possible.

Pediatric Patients: Treatment-naïve or treatment-experienced INSTI-naïve patients aged at least 4 weeks and weighing at least 3 kg. See Tables 2, 3, and 4 for complete pediatric dosing recommendations. (2.3, 2.4, 2.5). TIVICAY and TIVICAY PD are not bioequivalent and are not interchangeable on a milligram-per-milligram basis.

Pediatric Population Body Weight	Recommended Dose ^a TIVICAY PD Tablets for Oral Suspension
3 kg to less than 6 kg	5 mg once daily
6 kg to less than 10 kg	15 mg once daily
10 kg to less than 14 kg	20 mg once daily
14 kg to less than 20 kg	25 mg once daily
20 kg and greater	30 mg once daily

^a If certain UGT1A or CYP3A inducers are coadministered, then adjust the weight-based dose of TIVICAY to twice daily. (2.4, 2.5, 7.2, 7.3)

Alternative dosing recommendations for TIVICAY tablets for patients weighing at least 14 kg (Table 4):

- 14 kg to less than 20 kg: 40 mg once daily.
- 20 kg and greater: 50 mg once daily.

DOSAGE FORMS AND STRENGTHS

- TIVICAY tablets: 10 mg, 25 mg, and 50 mg (3)
- TIVICAY PD tablets for oral suspension: 5 mg (3)

CONTRAINDICATIONS

- Previous hypersensitivity reaction to dolutegravir. (4)
- Coadministration with dofetilide. (4)

WARNINGS AND PRECAUTIONS

- Hypersensitivity reactions characterized by rash, constitutional findings, and sometimes organ dysfunction, including liver injury, have been reported. Discontinue TIVICAY or TIVICAY PD and other suspect agents immediately if signs or symptoms of hypersensitivity reactions develop, as a delay in stopping treatment may result in a life-threatening reaction. (5.1)
- Hepatotoxicity has been reported in patients receiving dolutegravir-containing regimens. Patients with underlying hepatitis B or C may be at increased risk for worsening or development of transaminase elevations. Monitoring for hepatotoxicity is recommended. (5.2)
- Embryo-fetal toxicity may occur when used at the time of conception and in early pregnancy. An alternative treatment to dolutegravir should be considered at the time of conception through the first trimester of pregnancy due to the risk of neural tube defects. Counsel adolescents and adults of childbearing potential to use effective contraception. (2.1, 5.3, 8.1, 8.3)
- Immune reconstitution syndrome has been reported in patients treated with combination antiretroviral therapy. (5.5)
- TIVICAY tablets and TIVICAY PD tablets for oral suspension are not interchangeable. (2.3, 5.6)

ADVERSE REACTIONS

The most common adverse reactions of moderate to severe intensity and incidence at least 2% (in those receiving TIVICAY in any one adult trial) are insomnia, fatigue, and headache. (6.1)

To report SUSPECTED ADVERSE REACTIONS, contact ViiV Healthcare at 1-877-844-8872 or FDA at 1-800-FDA-1088 or www.fda.gov/medwatch.

DRUG INTERACTIONS

- Refer to the full prescribing information for important drug interactions with TIVICAY or TIVICAY PD. (4, 7)
- Drugs that are metabolic inducers may decrease the plasma concentrations of dolutegravir. (7.2, 7.3)
- TIVICAY or TIVICAY PD should be taken 2 hours before or 6 hours after taking cation-containing antacids or laxatives, sucralfate, oral supplements containing iron or calcium, or buffered medications. When taken with food, TIVICAY and supplements containing calcium or iron can be taken at the same time. (7.3)

USE IN SPECIFIC POPULATIONS

- Pregnancy: An alternative treatment to dolutegravir should be considered at the time of conception through the first trimester due to the risk of neural tube defects. (2.1, 5.3, 8.1)
- Lactation: Breastfeeding is not recommended due to the potential for HIV-1 transmission. (8.2)
- Females and males of reproductive potential: Pregnancy testing and contraception are recommended in adolescents and adults of childbearing potential. (8.3)

See 17 for PATIENT COUNSELING INFORMATION and FDA-approved patient labeling.

Revised: 06/2020

FULL PRESCRIBING INFORMATION: CONTENTS

1 INDICATIONS AND USAGE

2 DOSAGE AND ADMINISTRATION

- 2.1 Pregnancy Testing before Initiation
- 2.2 Recommended Dosage in Adults

2.3 General Dosing and Administration Instructions for Pediatric Patients

2.4 Recommended Dosage in Pediatric Patients Weighing 3 to 14 kg

- 2.5 Recommended Dosage in Pediatric Patients Weighing 14 kg or Greater
- 2.6 Additional Administration Instructions
- 3 DOSAGE FORMS AND STRENGTHS**
- 4 CONTRAINDICATIONS**
- 5 WARNINGS AND PRECAUTIONS**
 - 5.1 Hypersensitivity Reactions
 - 5.2 Hepatotoxicity
 - 5.3 Embryo-Fetal Toxicity
 - 5.4 Risk of Adverse Reactions or Loss of Virologic Response Due to Drug Interactions
 - 5.5 Immune Reconstitution Syndrome
 - 5.6 Different Formulations Are Not Interchangeable
- 6 ADVERSE REACTIONS**
 - 6.1 Clinical Trials Experience
 - 6.2 Postmarketing Experience
- 7 DRUG INTERACTIONS**
 - 7.1 Effect of Dolutegravir on the Pharmacokinetics of Other Agents
 - 7.2 Effect of Other Agents on the Pharmacokinetics of Dolutegravir
 - 7.3 Established and Other Potentially Significant Drug Interactions
 - 7.4 Drugs without Clinically Significant Interactions with Dolutegravir

- 8 USE IN SPECIFIC POPULATIONS**
 - 8.1 Pregnancy
 - 8.2 Lactation
 - 8.3 Females and Males of Reproductive Potential
 - 8.4 Pediatric Use
 - 8.5 Geriatric Use
 - 8.6 Hepatic Impairment
 - 8.7 Renal Impairment
 - 10 OVERDOSAGE**
 - 11 DESCRIPTION**
 - 12 CLINICAL PHARMACOLOGY**
 - 12.1 Mechanism of Action
 - 12.2 Pharmacodynamics
 - 12.3 Pharmacokinetics
 - 12.4 Microbiology
 - 13 NONCLINICAL TOXICOLOGY**
 - 13.1 Carcinogenesis, Mutagenesis, Impairment of Fertility
 - 14 CLINICAL STUDIES**
 - 14.1 Description of Clinical Studies
 - 14.2 Adult Subjects
 - 14.3 Pediatric Subjects
 - 16 HOW SUPPLIED/STORAGE AND HANDLING**
 - 17 PATIENT COUNSELING INFORMATION**
- *Sections or subsections omitted from the full prescribing information are not listed.

FULL PRESCRIBING INFORMATION

1 INDICATIONS AND USAGE

TIVICAY and TIVICAY PD are indicated in combination with other antiretroviral agents for the treatment of human immunodeficiency virus type 1 (HIV-1) infection in adults (treatment-naïve or -experienced) and in pediatric patients (treatment-naïve or -experienced but integrase strand transfer inhibitor [INSTI]-naïve) aged at least 4 weeks and weighing at least 3 kg [*see Microbiology (12.4)*].

TIVICAY is indicated in combination with rilpivirine as a complete regimen for the treatment of HIV-1 infection in adults to replace the current antiretroviral regimen in those who are virologically suppressed (HIV-1 RNA less than 50 copies per mL) on a stable antiretroviral regimen for at least 6 months with no history of treatment failure or known substitutions associated with resistance to either antiretroviral agent.

2 DOSAGE AND ADMINISTRATION

2.1 Pregnancy Testing before Initiation

Perform pregnancy testing before initiation of dolutegravir in adolescents and adults of childbearing potential [*see Warnings and Precautions (5.3), Use in Specific Populations (8.1, 8.3)*].

2.2 Recommended Dosage in Adults

TIVICAY tablets may be taken with or without food.

Table 1. Dosing Recommendations for TIVICAY Tablets in Adult Patients

Population	Recommended Dosage
Treatment-naïve or treatment-experienced INSTI-naïve or virologically suppressed (HIV-1 RNA <50 copies per mL) adults switching to dolutegravir plus rilpivirine ^a	50 mg once daily
Treatment-naïve or treatment-experienced INSTI-naïve when coadministered with certain uridine diphosphate (UDP)-glucuronosyl transferase 1A1 (UGT1A) or cytochrome P450 (CYP)3A inducers [see <i>Drug Interactions (7.2, 7.3)</i>]	50 mg twice daily
INSTI-experienced with certain INSTI-associated resistance substitutions or clinically suspected INSTI resistance ^b [see <i>Microbiology (12.4)</i>]	50 mg twice daily

^a Rilpivirine dose is 25 mg once daily for those switching to dolutegravir plus rilpivirine.

^b Alternative combinations that do not include metabolic inducers should be considered where possible [see *Drug Interactions (7.3)*].

2.3 General Dosing and Administration Instructions for Pediatric Patients

Do not interchange TIVICAY tablets and TIVICAY PD tablets for oral suspension on a milligram-per-milligram basis due to differing pharmacokinetic profiles [see *Warnings and Precautions (5.6), Clinical Pharmacology (12.3)*]. If switching from the tablets to the tablets for oral suspension, follow the recommended dosage in Table 3. If switching from the tablets for oral suspension to the tablets, follow the recommended dosage in Table 4. See administration instructions in *Dosage and Administration (2.6)*.

2.4 Recommended Dosage in Pediatric Patients Weighing 3 to 14 kg

The recommended weight-based dosage of TIVICAY PD tablets for oral suspension in **pediatric patients weighing 3 to 14 kg** (4 weeks and older, treatment-naïve or treatment-experienced but naïve to INSTI treatment) is described in Table 2.

Do not use TIVICAY tablets in patients weighing 3 to 14 kg. See administration instructions in *Dosage and Administration (2.6)*.

Table 2. Recommended Dosage of TIVICAY PD in Pediatric Patients 4 Weeks and Older Weighing 3 to 14 kg

Body Weight	TIVICAY PD Tablets for Oral Suspension	
	Daily Dose^a	Number of 5-mg Tablets
3 kg to less than 6 kg	5 mg once daily	1
6 kg to less than 10 kg	15 mg once daily	3
10 kg to less than 14 kg	20 mg once daily	4

^a If certain UGT1A or CYP3A inducers are coadministered, then administer TIVICAY PD twice daily [see *Drug Interactions* (7.2, 7.3)].

2.5 Recommended Dosage in Pediatric Patients Weighing 14 kg or Greater

For **pediatric patients weighing 14 kg or greater** (4 weeks and older, treatment-naïve or treatment-experienced but naïve to INSTI treatment) administer either:

- TIVICAY PD tablets for oral suspension (preferred in pediatric patients weighing less than 20 kg) (Table 3), or
- TIVICAY tablets for oral use (Table 4)

Table 3. Recommended Dosage of TIVICAY PD Tablets for Oral Suspension in Pediatric Patients Weighing 14 kg or Greater

Body Weight	TIVICAY PD Tablets for Oral Suspension	
	Daily Dose ^a	Number of 5-mg Tablets
14 kg to less than 20 kg	25 mg once daily	5
20 kg and greater	30 mg once daily	6

^a If certain UGT1A or CYP3A inducers are coadministered, then administer TIVICAY PD twice daily [see *Drug Interactions* (7.2, 7.3)].

Table 4. Recommended Dosage of TIVICAY Tablets in Pediatric Patients Weighing 14 kg or Greater

Body Weight	TIVICAY Tablets	
	Daily Dose ^a	Number of Tablets
14 kg to less than 20 kg	40 mg once daily	4 x 10-mg
20 kg and greater	50 mg once daily	1 x 50-mg

^a If certain UGT1A or CYP3A inducers are coadministered, then administer TIVICAY twice daily [see *Drug Interactions* (7.2, 7.3)].

2.6 Additional Administration Instructions

Administer TIVICAY tablets and TIVICAY PD tablets for oral suspension with or without food.

Administration Instructions for TIVICAY PD

Do not chew, cut, or crush TIVICAY PD [see *Instructions for Use*]. Instruct patients (or instruct caregivers) to either:

- Swallow the tablets for oral suspension whole (if more than one tablet is required, swallow one tablet at a time to reduce the risk of choking), or
- Fully disperse the tablets for oral suspension in 5 mL of drinking water (if using 1 or 3 tablets for oral suspension) or 10 mL (if using 4, 5, or 6 tablets for oral suspension) in the supplied

cup; swirl the suspension so that no lumps remain. After full dispersion, administer the oral suspension within 30 minutes of mixing [*see Instructions for Use*].

3 DOSAGE FORMS AND STRENGTHS

TIVICAY Tablets:

10 mg: Each tablet contains 10 mg of dolutegravir (as dolutegravir sodium). Tablets are white, round, film-coated, biconvex tablets debossed with “SV 572” on one side and “10” on the other side.

25 mg: Each tablet contains 25 mg of dolutegravir (as dolutegravir sodium). Tablets are pale yellow, round, film-coated, biconvex tablets debossed with “SV 572” on one side and “25” on the other side.

50 mg: Each tablet contains 50 mg of dolutegravir (as dolutegravir sodium). Tablets are yellow, round, film-coated, biconvex tablets debossed with “SV 572” on one side and “50” on the other side.

TIVICAY PD Tablets for Oral Suspension:

Each tablet contains 5 mg of dolutegravir (as dolutegravir sodium). Tablets are white, round, strawberry cream flavored, film-coated, biconvex tablets debossed with “SV H7S” on one side and “5” on the other side.

4 CONTRAINDICATIONS

TIVICAY and TIVICAY PD are contraindicated in patients:

- with previous hypersensitivity reaction to dolutegravir [*see Warnings and Precautions (5.1)*].
- receiving dofetilide due to the potential for increased dofetilide plasma concentrations and the risk for serious and/or life-threatening events [*see Drug Interactions (7)*].

5 WARNINGS AND PRECAUTIONS

5.1 Hypersensitivity Reactions

Hypersensitivity reactions have been reported and were characterized by rash, constitutional findings, and sometimes organ dysfunction, including liver injury. The events were reported in less than 1% of subjects receiving TIVICAY in Phase 3 clinical trials. Discontinue TIVICAY or TIVICAY PD and other suspect agents immediately if signs or symptoms of hypersensitivity reactions develop (including, but not limited to, severe rash or rash accompanied by fever, general malaise, fatigue, muscle or joint aches, blisters or peeling of the skin, oral blisters or lesions, conjunctivitis, facial edema, hepatitis, eosinophilia, angioedema, difficulty breathing). Clinical status, including liver aminotransferases, should be monitored and appropriate therapy initiated. Delay in stopping treatment with TIVICAY or TIVICAY PD or other suspect agents after the onset of hypersensitivity may result in a life-threatening reaction. TIVICAY and

TIVICAY PD are contraindicated in patients who have experienced a previous hypersensitivity reaction to dolutegravir.

5.2 Hepatotoxicity

Hepatic adverse events have been reported in patients receiving a dolutegravir-containing regimen. Patients with underlying hepatitis B or C may be at increased risk for worsening or development of transaminase elevations with use of TIVICAY or TIVICAY PD [see *Adverse Reactions (6.1)*]. In some cases, the elevations in transaminases were consistent with immune reconstitution syndrome or hepatitis B reactivation particularly in the setting where anti-hepatitis therapy was withdrawn. Cases of hepatic toxicity, including elevated serum liver biochemistries, hepatitis, and acute liver failure have been reported in patients receiving a dolutegravir-containing regimen without pre-existing hepatic disease or other identifiable risk factors. Drug-induced liver injury leading to liver transplant has been reported with TRIUMEQ (abacavir, dolutegravir, and lamivudine). Monitoring for hepatotoxicity is recommended.

5.3 Embryo-Fetal Toxicity

An observational study showed an association between TIVICAY and an increased risk of neural tube defects when TIVICAY was administered at the time of conception and in early pregnancy. As there is limited understanding of reported types of neural tube defects associated with dolutegravir use and because the date of conception may not be determined with precision, an alternative treatment to TIVICAY should be considered at the time of conception through the first trimester of pregnancy [see *Use in Specific Populations (8.1)*].

Perform pregnancy testing before initiation of dolutegravir in adolescents and adults of childbearing potential to exclude use of dolutegravir during the first trimester of pregnancy [see *Dosage and Administration (2.1)*]. Initiation of dolutegravir is not recommended in adolescents and adults actively trying to become pregnant unless there is no suitable alternative [see *Use in Specific Populations (8.1, 8.3)*].

Counsel adolescents and adults of childbearing potential to consistently use effective contraception [see *Use in Specific Populations (8.1, 8.3)*].

In adolescents and adults of childbearing potential currently on dolutegravir who are actively trying to become pregnant, or if pregnancy is confirmed in the first trimester, assess the risks and benefits of continuing dolutegravir versus switching to another antiretroviral regimen and consider switching to an alternative regimen [see *Use in Specific Populations (8.1, 8.3)*].

Dolutegravir may be considered during the second and third trimesters of pregnancy if the expected benefit justifies the potential risk to the pregnant woman and the fetus.

5.4 Risk of Adverse Reactions or Loss of Virologic Response Due to Drug Interactions

The concomitant use of TIVICAY or TIVICAY PD and other drugs may result in known or potentially significant drug interactions, some of which may lead to [see *Contraindications (4)*, *Drug Interactions (7.3)*]:

- Loss of therapeutic effect of TIVICAY or TIVICAY PD and possible development of resistance.
- Possible clinically significant adverse reactions from greater exposures of concomitant drugs.

For concomitant drugs for which the interaction can be mitigated, please see Table 8 for steps to prevent or manage these possible and known significant drug interactions, including dosing recommendations. Consider the potential for drug interactions prior to and during therapy with TIVICAY or TIVICAY PD; review concomitant medications during therapy with TIVICAY or TIVICAY PD; and monitor for the adverse reactions associated with the concomitant drugs.

5.5 Immune Reconstitution Syndrome

Immune reconstitution syndrome has been reported in patients treated with combination antiretroviral therapy, including TIVICAY or TIVICAY PD. During the initial phase of combination antiretroviral treatment, patients whose immune systems respond may develop an inflammatory response to indolent or residual opportunistic infections (such as *Mycobacterium avium* infection, cytomegalovirus, *Pneumocystis jirovecii* pneumonia [PCP], or tuberculosis), which may necessitate further evaluation and treatment.

Autoimmune disorders (such as Graves' disease, polymyositis, and Guillain-Barré syndrome) have also been reported to occur in the setting of immune reconstitution; however, the time to onset is more variable and can occur many months after initiation of treatment.

5.6 Different Formulations Are Not Interchangeable

TIVICAY and TIVICAY PD are not bioequivalent and are not interchangeable on a milligram-per-milligram basis [see *Clinical Pharmacology (12.3)*]. If a pediatric patient switches from one formulation to the other, the dose must be adjusted for the new dosage formulation [see *Dosage and Administration (2.3)*]. Incorrect dosing of a given formulation may result in underdosing and loss of therapeutic effect and possible development of resistance or possible clinically significant adverse reactions from greater exposure of dolutegravir.

6 ADVERSE REACTIONS

The following serious adverse drug reactions are discussed in other sections of the labeling:

- Hypersensitivity reactions [see *Warnings and Precautions (5.1)*].
- Hepatotoxicity [see *Warnings and Precautions (5.2)*].
- Immune Reconstitution Syndrome [see *Warnings and Precautions (5.5)*].

6.1 Clinical Trials Experience

Because clinical trials are conducted under widely varying conditions, adverse reaction rates observed in the clinical trials of a drug cannot be directly compared with rates in the clinical trials of another drug and may not reflect the rates observed in practice.

Clinical Trials Experience in Adult Subjects

Treatment-Naïve Subjects: The safety assessment of TIVICAY in HIV-1–infected treatment-naïve subjects is based on the analyses of data from 2 international, multicenter, double-blind trials, SPRING-2 (ING113086) and SINGLE (ING114467) and data from the international, multicenter, open-label FLAMINGO (ING114915) trial.

In SPRING-2, 822 subjects were randomized and received at least 1 dose of either TIVICAY 50 mg once daily or raltegravir 400 mg twice daily, both in combination with fixed-dose dual nucleoside reverse transcriptase inhibitor (NRTI) treatment (either abacavir sulfate and lamivudine [EPZICOM] or emtricitabine/tenofovir [TRUVADA]). There were 808 subjects included in the efficacy and safety analyses. Through 96 weeks, the rate of adverse events leading to discontinuation was 2% in both treatment arms.

In SINGLE, 833 subjects were randomized and received at least 1 dose of either TIVICAY 50 mg with fixed-dose abacavir sulfate and lamivudine (EPZICOM) once daily or fixed-dose efavirenz/emtricitabine/tenofovir (ATRIPLA) once daily (study treatment was blinded through Week 96 and open-label from Week 96 through Week 144). Through 144 weeks, the rates of adverse events leading to discontinuation were 4% in subjects receiving TIVICAY 50 mg once daily + EPZICOM and 14% in subjects receiving ATRIPLA once daily.

Treatment-emergent adverse reactions of moderate to severe intensity observed in at least 2% of subjects in either treatment arm in SPRING-2 and SINGLE trials are provided in Table 5. Side-by-side tabulation is to simplify presentation; direct comparisons across trials should not be made due to differing trial designs.

Table 5. Treatment-Emergent Adverse Reactions of at Least Moderate Intensity (Grades 2 to 4) and at Least 2% Frequency in Treatment-Naïve Subjects in SPRING-2 (Week 96 Analysis) and SINGLE Trials (Week 144 Analysis)

System Organ Class/ Preferred Term	SPRING-2		SINGLE	
	TIVICAY 50 mg Once Daily + 2 NRTIs (n = 403)	Raltegravir 400 mg Twice Daily + 2 NRTIs (n = 405)	TIVICAY 50 mg + EPZICOM Once Daily (n = 414)	ATRIPLA Once Daily (n = 419)
Psychiatric				
Insomnia	<1%	<1%	3%	3%
Depression	<1%	<1%	1%	2%
Abnormal dreams	<1%	<1%	<1%	2%

Nervous System				
Dizziness	<1%	<1%	<1%	5%
Headache	<1%	<1%	2%	2%
Gastrointestinal				
Nausea	1%	1%	<1%	3%
Diarrhea	<1%	<1%	<1%	2%
Skin and Subcutaneous Tissue				
Rash ^a	0	<1%	<1%	6%
General Disorders				
Fatigue	<1%	<1%	2%	2%
Ear and Labyrinth				
Vertigo	0	<1%	0	2%

^a Includes pooled terms: rash, rash generalized, rash macular, rash maculo-papular, rash pruritic, and drug eruption.

In addition, Grade 1 insomnia was reported by 1% and less than 1% of subjects receiving TIVICAY and raltegravir, respectively, in SPRING-2; whereas in SINGLE the rates were 7% and 4% for TIVICAY and ATRIPLA, respectively. These events were not treatment limiting.

In a multicenter, open-label trial (FLAMINGO), 243 subjects received TIVICAY 50 mg once daily versus 242 subjects who received darunavir 800 mg/ritonavir 100 mg once daily, both in combination with investigator-selected NRTI background regimen (either EPZICOM or TRUVADA). There were 484 subjects included in the efficacy and safety analyses. Through 96 weeks, the rates of adverse events leading to discontinuation were 3% in subjects receiving TIVICAY and 6% in subjects receiving darunavir/ritonavir. The adverse reactions observed in FLAMINGO were generally consistent with those seen in SPRING-2 and SINGLE.

Treatment-Experienced, Integrase Strand Transfer Inhibitor-Naïve Subjects: In an international, multicenter, double-blind trial (ING111762, SAILING), 719 HIV-1–infected, antiretroviral treatment-experienced adults were randomized and received either TIVICAY 50 mg once daily or raltegravir 400 mg twice daily with investigator-selected background regimen consisting of up to 2 agents, including at least one fully active agent. At 48 weeks, the rates of adverse events leading to discontinuation were 3% in subjects receiving TIVICAY 50 mg once daily + background regimen and 4% in subjects receiving raltegravir 400 mg twice daily + background regimen.

The only treatment-emergent adverse reaction of moderate to severe intensity with at least 2% frequency in either treatment group was diarrhea, 2% (6 of 354) in subjects receiving TIVICAY 50 mg once daily + background regimen and 1% (5 of 361) in subjects receiving raltegravir 400 mg twice daily + background regimen.

Treatment-Experienced, Integrase Strand Transfer Inhibitor-Experienced Subjects: In a multicenter, open-label, single-arm trial (ING112574, VIKING-3), 183 HIV-1–infected, antiretroviral treatment-experienced adults with virological failure and current or historical evidence of raltegravir and/or elvitegravir resistance received TIVICAY 50 mg twice daily with the current failing background regimen for 7 days and with optimized background therapy from Day 8. The rate of adverse events leading to discontinuation was 4% of subjects at Week 48.

Treatment-emergent adverse reactions in VIKING-3 were generally similar compared with observations with the 50-mg once-daily dose in adult Phase 3 trials.

Virologically Suppressed Subjects: The adverse reactions observed for TIVICAY plus rilpivirine in the Week 48 analysis of pooled data from 2 identical, international, multicenter, open-label trials (SWORD-1 and SWORD-2) of 513 HIV-1–infected, virologically suppressed subjects switching from their current antiretroviral regimen to dolutegravir plus rilpivirine, were consistent with the adverse reaction profiles and severities for the individual components when administered with other antiretroviral agents. There were no adverse reactions (Grades 2 to 4) with an incidence of at least 2% in either treatment arm. The rates of adverse events leading to discontinuation were 4% in subjects receiving TIVICAY plus rilpivirine once daily and less than 1% in subjects who remained on their current antiretroviral regimen.

Less Common Adverse Reactions Observed in Treatment-Naïve and Treatment-Experienced Trials: The following adverse reactions occurred in less than 2% of treatment-naïve or treatment-experienced subjects receiving TIVICAY in a combination regimen in any one trial. These events have been included because of their seriousness and assessment of potential causal relationship.

Gastrointestinal Disorders: Abdominal pain, abdominal discomfort, flatulence, upper abdominal pain, vomiting.

Hepatobiliary Disorders: Hepatitis.

Musculoskeletal Disorders: Myositis.

Psychiatric Disorders: Suicidal ideation, attempt, behavior, or completion. These events were observed primarily in subjects with a pre-existing history of depression or other psychiatric illness.

Renal and Urinary Disorders: Renal impairment.

Skin and Subcutaneous Tissue Disorders: Pruritus.

Laboratory Abnormalities:

Treatment-Naïve Subjects: Selected laboratory abnormalities (Grades 2 to 4) with a worsening grade from baseline and representing the worst-grade toxicity in at least 2% of subjects are presented in Table 6. The mean change from baseline observed for selected lipid

values is presented in Table 7. Side-by-side tabulation is to simplify presentation; direct comparisons across trials should not be made due to differing trial designs.

Table 6. Selected Laboratory Abnormalities (Grades 2 to 4) in Treatment-Naïve Subjects in SPRING-2 (Week 96 Analysis) and SINGLE Trials (Week 144 Analysis)

Laboratory Parameter Preferred Term	SPRING-2		SINGLE	
	TIVICAY 50 mg Once Daily + 2 NRTIs (n = 403)	Raltegravir 400 mg Twice Daily + 2 NRTIs (n = 405)	TIVICAY 50 mg + EPZICOM Once Daily (n = 414)	ATRIPLA Once Daily (n = 419)
ALT				
Grade 2 (>2.5-5.0 x ULN)	4%	4%	3%	5%
Grade 3 to 4 (>5.0 x ULN)	2%	2%	1%	<1%
AST				
Grade 2 (>2.5-5.0 x ULN)	5%	3%	3%	4%
Grade 3 to 4 (>5.0 x ULN)	3%	2%	1%	3%
Total Bilirubin				
Grade 2 (1.6-2.5 x ULN)	3%	2%	<1%	<1%
Grade 3 to 4 (>2.5 x ULN)	<1%	<1%	<1%	<1%
Creatine kinase				
Grade 2 (6.0-9.9 x ULN)	2%	5%	5%	3%
Grade 3 to 4 (\geq 10.0 x ULN)	7%	4%	7%	8%
Hyperglycemia				
Grade 2 (126-250 mg/dL)	6%	6%	9%	6%
Grade 3 (>250 mg/dL)	<1%	2%	2%	<1%
Lipase				
Grade 2 (>1.5-3.0 x ULN)	7%	7%	11%	11%
Grade 3 to 4 (>3.0 x ULN)	2%	5%	5%	4%
Total neutrophils				
Grade 2 (0.75-0.99 x 10 ⁹)	4%	3%	4%	5%
Grade 3 to 4 (<0.75 x 10 ⁹)	2%	2%	3%	3%

ULN = Upper limit of normal.

Table 7. Mean Change from Baseline in Fasted Lipid Values in Treatment-Naïve Subjects in SPRING-2 (Week 96 Analysis^a) and SINGLE Trials (Week 144 Analysis^a)

Laboratory Parameter Preferred Term	SPRING-2		SINGLE	
	TIVICAY 50 mg Once Daily + 2 NRTIs (n = 403)	Raltegravir 400 mg Twice Daily + 2 NRTIs (n = 405)	TIVICAY 50 mg + EPZICOM Once Daily (n = 414)	ATRIPLA Once Daily (n = 419)
Cholesterol (mg/dL)	8.1	10.1	24.0	26.7
HDL cholesterol (mg/dL)	2.0	2.3	5.4	7.2
LDL cholesterol (mg/dL)	5.1	6.1	16.0	14.6
Triglycerides (mg/dL)	6.7	6.6	13.6	31.9

^a Subjects on lipid-lowering agents at baseline were excluded from these analyses (19 subjects in each arm in SPRING-2, and in SINGLE: TIVICAY + EPZICOM n = 30 and ATRIPLA n = 27). Ninety-four subjects initiated a lipid-lowering agent post-baseline; their last fasted on-treatment values (prior to starting the agent) were used regardless if they discontinued the agent (SPRING-2: TIVICAY n = 9, raltegravir n = 13; SINGLE: TIVICAY + EPZICOM n = 36, ATRIPLA n = 36).

Laboratory abnormalities observed in the FLAMINGO trial were generally consistent with observations in SPRING-2 and SINGLE.

Treatment-Experienced, Integrase Strand Transfer Inhibitor-Naïve Subjects: Laboratory abnormalities observed in SAILING were generally similar compared with observations seen in the treatment-naïve (SPRING-2 and SINGLE) trials.

Treatment-Experienced, Integrase Strand Transfer Inhibitor-Experienced Subjects: The most common treatment-emergent laboratory abnormalities (greater than 5% for Grades 2 to 4 combined) observed in VIKING-3 at Week 48 were elevated ALT (9%), AST (8%), cholesterol (10%), creatine kinase (6%), hyperglycemia (14%), and lipase (10%). Two percent (4 of 183) of subjects had a Grade 3 to 4 treatment-emergent hematology laboratory abnormality, with neutropenia (2% [3 of 183]) being the most frequently reported.

Virologically Suppressed Adults: Laboratory abnormalities observed in SWORD-1 and SWORD-2 were generally similar compared with observations seen in the other Phase 3 trials.

Hepatitis B and/or Hepatitis C Virus Co-infection: In Phase 3 trials, subjects with hepatitis B and/or C virus co-infection were permitted to enroll provided that baseline liver chemistry tests did not exceed 5 times the upper limit of normal. Overall, the safety profile in subjects with hepatitis B and/or C virus co-infection was similar to that observed in subjects without hepatitis B or C co-infection, although the rates of AST and ALT abnormalities were higher in the subgroup with hepatitis B and/or C virus co-infection for all treatment groups. Grades 2 to 4 ALT abnormalities in hepatitis B and/or C co-infected compared with HIV mono-infected subjects receiving TIVICAY were observed in 18% vs. 3% with the 50-mg once-daily

dose and 13% vs. 8% with the 50-mg twice-daily dose. Liver chemistry elevations consistent with immune reconstitution syndrome were observed in some subjects with hepatitis B and/or C at the start of therapy with TIVICAY, particularly in the setting where anti-hepatitis therapy was withdrawn [see *Warnings and Precautions (5.2)*].

Changes in Serum Creatinine: Dolutegravir has been shown to increase serum creatinine due to inhibition of tubular secretion of creatinine without affecting renal glomerular function [see *Clinical Pharmacology (12.2)*]. Increases in serum creatinine occurred within the first 4 weeks of treatment and remained stable through 96 weeks. In treatment-naïve subjects, a mean change from baseline of 0.15 mg per dL (range: -0.32 mg per dL to 0.65 mg per dL) was observed after 96 weeks of treatment. Creatinine increases were comparable by background NRTIs and were similar in treatment-experienced subjects.

Clinical Trials Experience in Pediatric Subjects

The safety and pharmacokinetics of TIVICAY and TIVICAY PD in HIV-1–infected pediatric subjects aged at least 4 weeks and weighing at least 3 kg was evaluated in the IMPAACT P1093 trial and 2 weight-band-based pharmacokinetic substudies of the ODYSSEY trial [see *Use in Specific Populations (8.4)*, *Clinical Pharmacology (12.3)*]. Overall, the safety data in these pediatric studies were similar to those seen in adults, and there was no clinically significant difference in dolutegravir exposure [see *Clinical Pharmacology (12.3)*].

IMPAACT P1093 is an ongoing, multicenter, open-label, non-comparative trial of HIV-1–infected pediatric subjects aged 4 weeks to less than 18 years [see *Use in Specific Populations (8.4)*, *Clinical Pharmacology (12.3)*, *Clinical Studies (14.3)*].

The safety analysis based on subjects (n = 75) who received the recommended dose (determined by weight and age) through Week 24 showed that 11% of subjects experienced drug-related clinical adverse reactions. The only Grade 1 to 2 drug-related clinical adverse reactions reported by more than one subject was immune reconstitution inflammatory syndrome (IRIS) (n = 2). There were no Grade 3 or 4 drug-related adverse reactions reported. No adverse reactions led to discontinuation.

The Grade 3 or 4 laboratory abnormalities reported in more than one subject were decreased neutrophil count (n = 11), decreased blood bicarbonate (n = 4), decreased hemoglobin (n = 3), increased lipase (n = 2), and increased blood potassium (n = 2). These laboratory events were not considered to be drug-related. Median laboratory values were similar at baseline and Week 24. Changes in median serum creatinine were similar to those observed in adults.

6.2 Postmarketing Experience

In addition to adverse reactions reported from clinical trials, the following adverse reactions have been identified during postmarketing use. Because these reactions are reported voluntarily from a population of uncertain size, it is not always possible to reliably estimate their frequency or establish a causal relationship to drug exposure.

Hepatobiliary Disorders

Acute liver failure, hepatotoxicity.

Investigations

Weight increased.

Musculoskeletal

Arthralgia, myalgia.

Psychiatric

Anxiety

7 DRUG INTERACTIONS

7.1 Effect of Dolutegravir on the Pharmacokinetics of Other Agents

In vitro, dolutegravir inhibited the renal organic cation transporters, OCT2 ($IC_{50} = 1.93$ microM) and multidrug and toxin extrusion transporter (MATE) 1 ($IC_{50} = 6.34$ microM). In vivo, dolutegravir inhibits tubular secretion of creatinine by inhibiting OCT2 and potentially MATE1. Dolutegravir may increase plasma concentrations of drugs eliminated via OCT2 or MATE1 (dofetilide, dalfampridine, and metformin, Table 8) [*see Contraindications (4), Drug Interactions (7.3)*].

In vitro, dolutegravir inhibited the basolateral renal transporters, organic anion transporter (OAT) 1 ($IC_{50} = 2.12$ microM) and OAT3 ($IC_{50} = 1.97$ microM). However, in vivo, dolutegravir did not alter the plasma concentrations of tenofovir or para-amino hippurate, substrates of OAT1 and OAT3.

In vitro, dolutegravir did not inhibit (IC_{50} greater than 50 microM) the following: CYP1A2, CYP2A6, CYP2B6, CYP2C8, CYP2C9, CYP2C19, CYP2D6, CYP3A, UGT1A1, UGT2B7, P-glycoprotein (P-gp), breast cancer resistance protein (BCRP), bile salt export pump (BSEP), organic anion transporter polypeptide (OATP)1B1, OATP1B3, OCT1, multidrug resistance protein (MRP)2, or MRP4. In vitro, dolutegravir did not induce CYP1A2, CYP2B6, or CYP3A4. Based on these data and the results of drug interaction trials, dolutegravir is not expected to affect the pharmacokinetics of drugs that are substrates of these enzymes or transporters.

7.2 Effect of Other Agents on the Pharmacokinetics of Dolutegravir

Dolutegravir is metabolized by UGT1A1 with some contribution from CYP3A. Dolutegravir is also a substrate of UGT1A3, UGT1A9, BCRP, and P-gp in vitro. Drugs that induce those enzymes and transporters may decrease dolutegravir plasma concentration and reduce the therapeutic effect of dolutegravir.

Coadministration of dolutegravir and other drugs that inhibit these enzymes may increase dolutegravir plasma concentration.

Etravirine significantly reduced plasma concentrations of dolutegravir, but the effect of etravirine was mitigated by coadministration of lopinavir/ritonavir or darunavir/ritonavir and is expected to be mitigated by atazanavir/ritonavir (Table 8) [see *Drug Interactions (7.3), Clinical Pharmacology (12.3)*].

In vitro, dolutegravir was not a substrate of OATP1B1 or OATP1B3.

7.3 Established and Other Potentially Significant Drug Interactions

Table 8 provides clinical recommendations as a result of drug interactions with TIVICAY or TIVICAY PD. These recommendations are based on either drug interaction trials or predicted interactions due to the expected magnitude of interaction and potential for serious adverse events or loss of efficacy [see *Dosage and Administration (2), Clinical Pharmacology (12.3)*].

Table 8. Established and Other Potentially Significant Drug Interactions: Alterations in Dose or Regimen May Be Recommended Based on Drug Interaction Trials or Predicted Interactions [see *Dosage and Administration (2)*]

Concomitant Drug Class: Drug Name	Effect on Concentration of Dolutegravir and/or Concomitant Drug	Clinical Comment
<i>HIV-1 Antiviral Agents</i>		
Non-nucleoside reverse transcriptase inhibitor: Etravirine ^a	↓Dolutegravir	Use of TIVICAY or TIVICAY PD with etravirine without coadministration of atazanavir/ritonavir, darunavir/ritonavir, or lopinavir/ritonavir is not recommended.
Non-nucleoside reverse transcriptase inhibitor: Efavirenz ^a	↓Dolutegravir	Adjust dose of TIVICAY to twice daily for treatment-naïve and treatment-experienced, INSTI-naïve adult patients. In pediatric patients, increase the weight-based dose of TIVICAY or TIVICAY PD to twice daily (Tables 2, 3, and 4). Use alternative combinations that do not include metabolic inducers where possible for INSTI-experienced patients with certain INSTI-associated

		resistance substitutions or clinically suspected INSTI resistance. ^b
Non-nucleoside reverse transcriptase inhibitor: Nevirapine	↓Dolutegravir	Avoid coadministration with nevirapine because there are insufficient data to make dosing recommendations.
Protease inhibitors: Fosamprenavir/ritonavir ^a Tipranavir/ritonavir ^a	↓Dolutegravir	Adjust dose of TIVICAY to twice daily for treatment-naïve and treatment-experienced, INSTI-naïve adult patients. In pediatric patients, increase the weight-based dose of TIVICAY or TIVICAY PD to twice daily (Tables 2, 3, and 4). Use alternative combinations that do not include metabolic inducers where possible for INSTI-experienced patients with certain INSTI-associated resistance substitutions or clinically suspected INSTI resistance. ^b
<i>Other Agents</i>		
Dofetilide	↑Dofetilide	Coadministration is contraindicated with TIVICAY or TIVICAY PD [<i>see Contraindications (4)</i>].
Carbamazepine ^a	↓Dolutegravir	Adjust dose of TIVICAY to twice daily in treatment-naïve or treatment-experienced, INSTI-naïve adult patients. In pediatric patients, increase the weight-based dose of TIVICAY or TIVICAY PD to twice daily (Tables 2, 3, and 4). Use alternative treatment that does not include carbamazepine where possible for INSTI-experienced patients with certain INSTI-associated resistance substitutions or clinically suspected INSTI resistance. ^b

Oxcarbazepine Phenytoin Phenobarbital St. John's wort (<i>Hypericum perforatum</i>)	↓Dolutegravir	Avoid coadministration with TIVICAY or TIVICAY PD because there are insufficient data to make dosing recommendations.
Medications containing polyvalent cations (e.g., Mg or Al): Cation-containing antacids ^a or laxatives Sucralfate Buffered medications	↓Dolutegravir	Administer TIVICAY or TIVICAY PD 2 hours before or 6 hours after taking medications containing polyvalent cations.
Oral calcium or iron supplements, including multivitamins containing calcium or iron^a	↓Dolutegravir	When taken with food, TIVICAY and supplements or multivitamins containing calcium or iron can be taken at the same time. Under fasting conditions, TIVICAY or TIVICAY PD should be taken 2 hours before or 6 hours after taking supplements containing calcium or iron.
Potassium channel blocker: Dalfampridine	↑Dalfampridine	Elevated levels of dalfampridine increase the risk of seizures. The potential benefits of taking dalfampridine concurrently with TIVICAY or TIVICAY PD should be considered against the risk of seizures in these patients.
Metformin	↑Metformin	Refer to the prescribing information for metformin for assessing the benefit and risk of concomitant use of TIVICAY or TIVICAY PD and metformin.
Rifampin ^a	↓Dolutegravir	Adjust dose of TIVICAY to twice daily for treatment-naïve and treatment-experienced, INSTI-naïve adult patients. In pediatric patients, increase the weight-based dose of TIVICAY or

		<p>TIVICAY PD to twice daily (Tables 2, 3, and 4).</p> <p>Use alternatives to rifampin where possible for INSTI-experienced patients with certain INSTI-associated resistance substitutions or clinically suspected INSTI resistance.^b</p>
--	--	---

^a See *Clinical Pharmacology (12.3) Table 11 or Table 12 for magnitude of interaction.*

^b The lower dolutegravir exposures observed in INSTI-experienced patients (with certain INSTI-associated resistance substitutions or clinically suspected INSTI resistance [*see Microbiology (12.4)*]) upon coadministration with certain inducers may result in loss of therapeutic effect and development of resistance to TIVICAY or other coadministered antiretroviral agents.

7.4 Drugs without Clinically Significant Interactions with Dolutegravir

Based on drug interaction trial results, the following drugs can be coadministered with dolutegravir without a dose adjustment: atazanavir/ritonavir, darunavir/ritonavir, daclatasvir, elbasvir/grazoprevir, methadone, midazolam, omeprazole, oral contraceptives containing norgestimate and ethinyl estradiol, prednisone, rifabutin, rilpivirine, sofosbuvir/velpatasvir, and tenofovir [*see Clinical Pharmacology (12.3)*].

8 USE IN SPECIFIC POPULATIONS

8.1 Pregnancy

Pregnancy Exposure Registry

There is a pregnancy exposure registry that monitors pregnancy outcomes in individuals exposed to TIVICAY or TIVICAY PD during pregnancy. Healthcare providers are encouraged to register patients by calling the Antiretroviral Pregnancy Registry (APR) at 1-800-258-4263.

Risk Summary

Data from a birth outcome surveillance study has identified an increased risk of neural tube defects when TIVICAY is administered at the time of conception compared with non-dolutegravir-containing antiretroviral regimens. As defects related to closure of the neural tube occur from conception through the first 6 weeks of gestation, embryos exposed to dolutegravir from the time of conception through the first 6 weeks of gestation are at potential risk. In addition, 2 of the 5 birth defects (encephalocele and iniencephaly), which have been observed with dolutegravir use, although often termed neural tube defects, may occur post-neural tube closure, the time period of which may be later than 6 weeks of gestation, but within the first trimester. Due to the limited understanding of the types of reported neural tube defects associated with dolutegravir use and because the date of conception may not be determined with precision, an alternative treatment to dolutegravir should be considered at the time of conception through

the first trimester of pregnancy. Initiation of dolutegravir is not recommended in adolescents and adults actively trying to become pregnant unless there is no suitable alternative (*see Data*).

In adolescents and adults of childbearing potential currently on dolutegravir who are actively trying to become pregnant, or if pregnancy is confirmed in the first trimester, assess the risks and benefits of continuing dolutegravir versus switching to another antiretroviral regimen and consider switching to an alternative regimen. Advise pregnant adolescents and adults of the potential risk to the embryo exposed to dolutegravir from the time of conception through the first trimester of pregnancy. A benefit-risk assessment should consider factors such as feasibility of switching, tolerability, ability to maintain viral suppression, and risk of transmission to the infant against the risk of neural tube defects [*see Warnings and Precaution (5.3)*].

There are insufficient human data on the use of dolutegravir during pregnancy to definitively assess a drug-associated risk for birth defects and miscarriage. The background risk for major birth defects for the indicated population is unknown. In the U.S. general population, the estimated background rate for major birth defects and miscarriage in clinically recognized pregnancies is 2% to 4% and 15% to 20%, respectively.

In animal reproduction studies, no evidence of adverse developmental outcomes was observed with dolutegravir at systemic exposures (AUC) less than (rabbits) and approximately 27 times (rats) the exposure in humans at the maximum recommended human dose (MRHD) of TIVICAY (*see Data*).

Data

Human Data: In a birth outcome surveillance study in Botswana, there were 5 cases of neural tube defects reported out of 1,683 deliveries (0.3%) to women who were exposed to dolutegravir-containing regimens at the time of conception. In comparison, the neural tube defect prevalence rates were 0.1% (15/14,792 deliveries) in the non-dolutegravir arm and 0.08% (70/89,372 deliveries) in the HIV-uninfected arm. Five cases reported with dolutegravir included one case each of encephalocele, anencephaly, and iniencephaly, and 2 cases of myelomeningocele. In the same study, one infant out of 3,840 (0.03%) deliveries to women who started dolutegravir during pregnancy had a neural tube defect, compared with 3 infants out of 5,952 (0.05%) deliveries to women who started non-dolutegravir-containing regimens during pregnancy.

Data analyzed to date from other sources including the APR, clinical trials, and postmarketing data are insufficient to address the risk of neural tube defects with dolutegravir.

Data from the birth outcome surveillance study described above and postmarketing sources with more than 1,000 pregnancy outcomes from second and third trimester exposure in pregnant women indicate no evidence of increased risk of adverse birth outcomes.

Animal Data: Dolutegravir was administered orally at up to 1,000 mg per kg daily to pregnant rats and rabbits on Gestation Days 6 to 17 and 6 to 18, respectively, and to rats on Gestation Day

6 to Lactation/Postpartum Day 20. No adverse effects on embryo-fetal (rats and rabbits) or pre/postnatal (rats) development were observed at up to the highest dose tested. During organogenesis, systemic exposures (AUC) to dolutegravir in rabbits were less than the exposure in humans at the MRHD and in rats were approximately 27 times the exposure in humans at the MRHD. In the rat pre/postnatal development study, decreased body weight of the developing offspring was observed during lactation at a maternally toxic dose (approximately 27 times human exposure at the MRHD).

8.2 Lactation

Risk Summary

The Centers for Disease Control and Prevention recommends that HIV-1–infected mothers in the United States not breastfeed their infants to avoid risking postnatal transmission of HIV-1 infection.

It is not known whether dolutegravir is present in human breast milk, affects human milk production, or has effects on the breastfed infant. When administered to lactating rats, dolutegravir was present in milk (*see Data*).

Because of the potential for (1) HIV-1 transmission (in HIV-negative infants), (2) developing viral resistance (in HIV-positive infants), and (3) adverse reactions in a breastfed infant similar to those seen in adults, instruct mothers not to breastfeed if they are receiving dolutegravir.

Data

Animal Data: Dolutegravir was the primary drug-related component excreted into the milk of lactating rats following a single oral dose of 50 mg per kg on Lactation Day 10, with milk concentrations of up to approximately 1.3 times that of maternal plasma concentrations observed 8 hours postdose.

8.3 Females and Males of Reproductive Potential

Pregnancy Testing

Perform pregnancy testing in adolescents and adults of childbearing potential before initiation of dolutegravir [*see Dosage and Administration (2.1)*].

Contraception

In adolescents and adults of childbearing potential currently on dolutegravir who are actively trying to become pregnant, or if pregnancy is confirmed in the first trimester, assess the risks and benefits of continuing dolutegravir versus switching to another antiretroviral regimen and consider switching to an alternative regimen [*see Warnings and Precautions (5.3), Use in Specific Populations (8.1)*].

Counsel adolescents and adults of childbearing potential who are taking dolutegravir to consistently use effective contraception.

8.4 Pediatric Use

The safety, pharmacokinetics, and effectiveness of TIVICAY and TIVICAY PD were evaluated in 75 HIV-1–infected, treatment-naïve or treatment-experienced, INSTI-naïve pediatric and adolescent subjects aged 4 weeks to less than 18 years weighing at least 3 kg in an ongoing, open-label, multicenter, dose-finding clinical trial, IMPAACT P1093 [see *Adverse Reactions (6.1)*, *Clinical Pharmacology (12.3)*, *Clinical Studies (14.3)*]. Additional pharmacokinetics data were evaluated in 2 pharmacokinetic substudies in ODYSSEY, an ongoing open-label, randomized, non-inferiority trial to evaluate the safety, efficacy, and pharmacokinetic parameters of TIVICAY or TIVICAY PD plus two NRTIs compared with standard of care in HIV-1–infected pediatric subjects younger than 18 years [see *Clinical Pharmacology (12.3)*].

Overall, the safety data in pediatric subjects from the IMPAACT P1093 trial were comparable to those observed in adults [see *Adverse Reactions (6.1)*]. The pharmacokinetic parameters of TIVICAY or TIVICAY PD in pediatric subjects from IMPAACT P1093 and ODYSSEY were comparable to those of adults receiving 50 mg once daily or twice daily [see *Clinical Pharmacology (12.3)*]. The effectiveness observed in IMPAACT P1093 is comparable to that of treatment-experienced adult subjects.

Safety and effectiveness of TIVICAY or TIVICAY PD have not been established in pediatric patients aged less than 4 weeks or weighing less than 3 kg or in any pediatric patients who are INSTI-experienced with documented or clinically suspected resistance to other INSTIs (e.g., raltegravir, elvitegravir).

8.5 Geriatric Use

Clinical trials of TIVICAY did not include sufficient numbers of subjects aged 65 and older to determine whether they respond differently from younger subjects. In general, caution should be exercised in the administration of TIVICAY in elderly patients reflecting the greater frequency of decreased hepatic, renal, or cardiac function, and of concomitant disease or other drug therapy [see *Clinical Pharmacology (12.3)*].

8.6 Hepatic Impairment

No clinically important pharmacokinetic differences between subjects with moderate hepatic impairment and matching healthy subjects were observed. No dosage adjustment is necessary for patients with mild to moderate hepatic impairment (Child-Pugh Score A or B). The effect of severe hepatic impairment (Child-Pugh Score C) on the pharmacokinetics of dolutegravir has not been studied. Therefore, TIVICAY and TIVICAY PD are not recommended for use in patients with severe hepatic impairment [see *Clinical Pharmacology (12.3)*].

8.7 Renal Impairment

Dolutegravir plasma concentrations were decreased in subjects with severe renal impairment compared with those in matched healthy controls. However, no dosage adjustment is necessary for treatment-naïve or treatment-experienced and INSTI-naïve patients with mild, moderate, or

severe renal impairment or for INSTI-experienced patients (with certain INSTI-associated resistance substitutions or clinically suspected INSTI resistance) with mild or moderate renal impairment. Caution is warranted for INSTI-experienced patients (with certain INSTI-associated resistance substitutions or clinically suspected INSTI resistance [see *Microbiology (12.4)*]) with severe renal impairment, as the decrease in dolutegravir concentrations may result in loss of therapeutic effect and development of resistance to TIVICAY, TIVICAY PD, or other coadministered antiretroviral agents [see *Clinical Pharmacology (12.3)*]. There is inadequate information to recommend appropriate dosing of dolutegravir in patients requiring dialysis.

10 OVERDOSAGE

There is no known specific treatment for overdose with TIVICAY or TIVICAY PD. If overdose occurs, the patient should be monitored, and standard supportive treatment applied as required. As dolutegravir is highly bound to plasma proteins, it is unlikely that it will be significantly removed by dialysis.

11 DESCRIPTION

TIVICAY contains dolutegravir, as dolutegravir sodium, an HIV INSTI. The chemical name of dolutegravir sodium is sodium (4*R*,12*aS*)-9-{[(2,4-difluorophenyl)methyl]carbamoyl}-4-methyl-6,8-dioxo-3,4,6,8,12,12*a*-hexahydro-2*H*-pyrido[1',2':4,5]pyrazino[2,1-*b*][1,3]oxazin-7-olate. The empirical formula is C₂₀H₁₈F₂N₃NaO₅ and the molecular weight is 441.36 g per mol. It has the following structural formula:

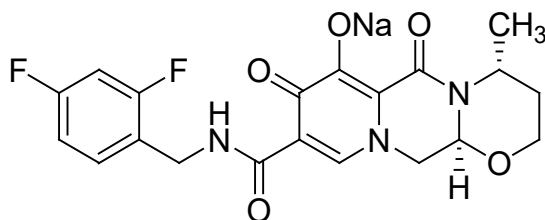

Dolutegravir sodium is a white to light yellow powder and is slightly soluble in water.

Each film-coated tablet of TIVICAY for oral administration contains 10.5, 26.3, or 52.6 mg of dolutegravir sodium, which is equivalent to 10, 25, or 50 mg dolutegravir free acid, respectively, and the following inactive ingredients: D-mannitol, microcrystalline cellulose, povidone K29/32, sodium starch glycolate, and sodium stearyl fumarate. The tablet film-coating contains the inactive ingredients iron oxide yellow (25-mg and 50-mg tablets only), macrogol/PEG, polyvinyl alcohol-part hydrolyzed, talc, and titanium dioxide.

Each TIVICAY PD tablet for oral suspension contains 5.26 mg of dolutegravir sodium, which is equivalent to 5 mg dolutegravir free acid, and the following inactive ingredients: calcium sulfate dihydrate, crospovidone, mannitol, microcrystalline cellulose, povidone K29/32, silicified microcrystalline cellulose, sodium starch glycolate, strawberry cream flavor, sucralose, and

sodium stearyl fumarate. The tablet film-coating contains hypromellose, polyethylene glycol, and titanium dioxide.

12 CLINICAL PHARMACOLOGY

12.1 Mechanism of Action

Dolutegravir is an HIV-1 antiretroviral agent [*see Microbiology (12.4)*].

12.2 Pharmacodynamics

Effects on Electrocardiogram

In a randomized, placebo-controlled, cross-over trial, 42 healthy subjects received single-dose oral administrations of placebo, dolutegravir 250-mg suspension (exposures approximately 3-fold of the 50-mg once-daily dose at steady state), and moxifloxacin 400 mg (active control) in random sequence. After baseline and placebo adjustment, the maximum mean QTc change based on Fridericia correction method (QTcF) for dolutegravir was 2.4 msec (1-sided 95% upper CI: 4.9 msec). TIVICAY did not prolong the QTc interval over 24 hours postdose.

Effects on Renal Function

The effect of dolutegravir on renal function was evaluated in an open-label, randomized, 3-arm, parallel, placebo-controlled trial in healthy subjects (n = 37) who received dolutegravir 50 mg once daily (n = 12), dolutegravir 50 mg twice daily (n = 13), or placebo once daily (n = 12) for 14 days. A decrease in creatinine clearance, as determined by 24-hour urine collection, was observed with both doses of dolutegravir after 14 days of treatment in subjects who received 50 mg once daily (9% decrease) and 50 mg twice daily (13% decrease). Neither dose of dolutegravir had a significant effect on the actual glomerular filtration rate (determined by the clearance of probe drug, iohexol) or effective renal plasma flow (determined by the clearance of probe drug, para-amino hippurate) compared with the placebo.

12.3 Pharmacokinetics

The pharmacokinetic properties of dolutegravir have been evaluated in healthy adult subjects and HIV-1–infected adult subjects. Exposure to dolutegravir was generally similar between healthy subjects and HIV-1–infected subjects. The non-linear exposure of dolutegravir following 50 mg twice daily compared with 50 mg once daily in HIV-1–infected subjects (Table 9) was attributed to the use of metabolic inducers in the background antiretroviral regimens of subjects receiving dolutegravir 50 mg twice daily in clinical trials.

Table 9. Dolutegravir Steady-State Pharmacokinetic Parameter Estimates in HIV-1–Infected Adults

Parameter	50 mg Once Daily Geometric Mean ^a (%CV)	50 mg Twice Daily Geometric Mean ^b (%CV)
AUC ₍₀₋₂₄₎ (mcg.h/mL)	53.6 (27)	75.1 (35)
C _{max} (mcg/mL)	3.67 (20)	4.15 (29)
C _{min} (mcg/mL)	1.11 (46)	2.12 (47)

^a Based on population pharmacokinetic analyses using data from SPRING-1 and SPRING-2.

^b Based on population pharmacokinetic analyses using data from VIKING (ING112961) and VIKING-3.

TIVICAY tablets and TIVICAY PD tablets for oral suspension are not bioequivalent. The relative bioavailability of TIVICAY PD is approximately 1.6-fold higher than TIVICAY; therefore, the 2 dosage forms are not interchangeable on a milligram-per-milligram basis [*see Dosage and Administration (2.3)*].

Absorption

Following oral administration of dolutegravir, peak plasma concentrations were observed 2 to 3 hours postdose. With once-daily dosing, pharmacokinetic steady state is achieved within approximately 5 days with average accumulation ratios for AUC, C_{max}, and C_{24 h} ranging from 1.2 to 1.5.

Dolutegravir plasma concentrations increased in a less than dose-proportional manner above 50 mg. Dolutegravir is a P-gp substrate in vitro. The absolute bioavailability of dolutegravir has not been established.

Effect of Food: TIVICAY or TIVICAY PD may be taken with or without food. Food increased the extent of absorption and slowed the rate of absorption of dolutegravir following a 50-mg dose of TIVICAY. Low-, moderate-, and high-fat meals increased dolutegravir AUC_(0-∞) by 33%, 41%, and 66%; increased C_{max} by 46%, 52%, and 67%; and prolonged T_{max} to 3, 4, and 5 hours from 2 hours under fasted conditions, respectively.

Distribution

Dolutegravir is highly bound (greater than or equal to 98.9%) to human plasma proteins based on in vivo data and binding is independent of plasma concentration of dolutegravir. The apparent volume of distribution (Vd/F) following 50-mg once-daily administration is estimated at 17.4 L based on a population pharmacokinetic analysis.

Cerebrospinal Fluid (CSF): In 12 treatment-naïve subjects on dolutegravir 50 mg daily plus abacavir/lamivudine, the median dolutegravir concentration in CSF was 13.2 ng per mL (range: 3.74 ng per mL to 18.3 ng per mL) 2 to 6 hours postdose after 16 weeks of treatment. The clinical relevance of this finding has not been established.

Elimination

Dolutegravir has a terminal half-life of approximately 14 hours and an apparent clearance (CL/F) of 1.0 L per hour based on population pharmacokinetic analyses.

Metabolism: Dolutegravir is primarily metabolized via UGT1A1 with some contribution from CYP3A.

Polymorphisms in Drug-Metabolizing Enzymes: In a meta-analysis of healthy subject trials, subjects with UGT1A1 (n = 7) genotypes conferring poor dolutegravir metabolism had a 32% lower clearance of dolutegravir and 46% higher AUC compared with subjects with genotypes associated with normal metabolism via UGT1A1 (n = 41).

Excretion: After a single oral dose of [¹⁴C] dolutegravir, 53% of the total oral dose was excreted unchanged in feces. Thirty-one percent of the total oral dose was excreted in urine, represented by an ether glucuronide of dolutegravir (18.9% of total dose), a metabolite formed by oxidation at the benzylic carbon (3.0% of total dose), and its hydrolytic N-dealkylation product (3.6% of total dose). Renal elimination of unchanged drug was low (less than 1% of the dose).

Specific Populations

Pediatric Patients: The pharmacokinetics of dolutegravir were evaluated in the IMPAACT P1093 trial and in 2 weight-band-based pharmacokinetic substudies from the ODYSSEY trial. Steady-state plasma exposure at doses by weight band are summarized in Table 10 [see *Clinical Studies (14.3)*].

Mean dolutegravir AUC_{0-24h} and C_{24h} in HIV-1–infected pediatric subjects were comparable to those in adults after 50 mg once daily or 50 mg twice daily. Mean C_{max} is higher in pediatrics, but the increase is not considered clinically significant as the safety profiles were similar in pediatric and adult subjects [see *Use in Specific Populations (8.4)*].

Table 10. Summary of Pharmacokinetic Parameters in Pediatric HIV-1–Infected Subjects (Pooled Analyses for IMPAACT P1093 and ODYSSEY^a Trials)

Weight Band	Dose ^b of TIVICAY or TIVICAY PD	n	Pharmacokinetic Parameter Geometric Mean (%CV)		
			C _{max} (mcg/mL)	AUC _{0-24h} (mcg·h/mL)	C _{24h} (ng/mL)
3 kg to <6 kg	TIVICAY PD 5 mg once daily	8	3.80 (34)	49.37 (49)	962 (98)
6 kg to <10 kg	TIVICAY PD 15 mg once daily	17	5.27 (50)	57.17 (76)	706 (177)
10 kg to <14 kg	TIVICAY PD 20 mg once daily	13	5.99 (33)	68.75 (48)	977 (100)

14 kg to <20 kg	TIVICAY PD 25 mg once daily	19	5.97 (42)	58.97 (44)	725 (75)
20 kg to <25 kg	TIVICAY PD 30 mg once daily	9	7.16 (26)	71.53 (26)	759 (73)
≥20 kg	TIVICAY 50 mg once daily	49	4.92 (40)	54.98 (43)	778 (62)

^a Data from 2 weight-band-based pharmacokinetic substudies in the ODYSSEY trial.

^b The bioavailability of TIVICAY PD tablets for oral suspension is ~1.6-fold that of TIVICAY tablets.

Geriatric Patients: Population pharmacokinetic analysis indicated age had no clinically relevant effect on the pharmacokinetics of dolutegravir.

Patients with Hepatic Impairment: In a trial comparing 8 subjects with moderate hepatic impairment (Child-Pugh Score B) with 8 matched healthy controls, exposure of dolutegravir from a single 50-mg dose was similar between the 2 groups. The effect of severe hepatic impairment (Child-Pugh Score C) on the pharmacokinetics of dolutegravir has not been studied.

Patients with Renal Impairment: In a trial evaluating the pharmacokinetics of a single 50-mg tablet of dolutegravir comparing 8 subjects with severe renal impairment (CrCl less than 30 mL per min) with 8 matched healthy controls, AUC, C_{max}, and C₂₄ of dolutegravir were lower by 40%, 23%, and 43%, respectively, compared with those in matched healthy subjects. Population pharmacokinetic analysis using data from SAILING and VIKING-3 trials indicated that mild and moderate renal impairment had no clinically relevant effect on the exposure of dolutegravir. There is inadequate information to recommend appropriate dosing of dolutegravir in patients requiring dialysis.

HBV or HCV Co-infected Patients: Population analyses using pooled pharmacokinetic data from adult trials indicated no clinically relevant effect of HCV co-infection on the pharmacokinetics of dolutegravir. There were limited data on HBV co-infection.

Gender and Race: Population analyses using pooled pharmacokinetic data from adult trials indicated gender and race had no clinically relevant effect on the exposure of dolutegravir.

Drug Interaction Studies

Drug interaction trials were performed with TIVICAY and other drugs likely to be coadministered or commonly used as probes for pharmacokinetic interactions. The effects of dolutegravir on the exposure of coadministered drugs are summarized in Table 11 and the effects of coadministered drugs on the exposure of dolutegravir are summarized in Table 12.

Dosing or regimen recommendations as a result of established and other potentially significant drug-drug interactions with TIVICAY are provided in Table 8 [see *Dosage and Administration* (2.2), *Drug Interactions* (7.3)].

Table 11. Summary of Effect of Dolutegravir on the Pharmacokinetics of Coadministered Drugs

Coadministered Drug(s) and Dose(s)	Dose of TIVICAY	n	Geometric Mean Ratio (90% CI) of Pharmacokinetic Parameters of Coadministered Drug with/without Dolutegravir No Effect = 1.00		
			C _{max}	AUC	C _τ or C ₂₄
Daclatasvir 60 mg once daily	50 mg once daily	12	1.03 (0.84 to 1.25)	0.98 (0.83 to 1.15)	1.06 (0.88 to 1.29)
Elbasvir 50 mg once daily	50 mg single dose	12	0.97 (0.89, 1.05)	0.98 (0.93, 1.04)	0.98 (0.93, 1.03)
Ethinyl estradiol 0.035 mg	50 mg twice daily	15	0.99 (0.91 to 1.08)	1.03 (0.96 to 1.11)	1.02 (0.93 to 1.11)
Grazoprevir 200 mg once daily	50 mg single dose	12	0.64 (0.44, 0.93)	0.81 (0.67, 0.97)	0.86 (0.79, 0.93)
Metformin 500 mg twice daily	50 mg once daily	15 ^a	1.66 (1.53 to 1.81)	1.79 (1.65 to 1.93)	–
Metformin 500 mg twice daily	50 mg twice daily	15 ^a	2.11 (1.91 to 2.33)	2.45 (2.25 to 2.66)	–
Methadone 16 to 150 mg	50 mg twice daily	11	1.00 (0.94 to 1.06)	0.98 (0.91 to 1.06)	0.99 (0.91 to 1.07)
Midazolam 3 mg	25 mg once daily	10	–	0.95 (0.79 to 1.15)	–
Norelgestromin 0.25 mg	50 mg twice daily	15	0.89 (0.82 to 0.97)	0.98 (0.91 to 1.04)	0.93 (0.85 to 1.03)
Rilpivirine 25 mg once daily	50 mg once daily	16	1.10 (0.99 to 1.22)	1.06 (0.98 to 1.16)	1.21 (1.07 to 1.38)
Sofosbuvir 400 mg once daily Metabolite (GS-331007)	50 mg once daily	24	0.88 (0.80, 0.98) 1.01 (0.93, 1.10)	0.92 (0.85, 0.99) 0.99 (0.97, 1.01)	NA 0.99 (0.97, 1.01)
Tenofovir disoproxil fumarate 300 mg once daily	50 mg once daily	15	1.09 (0.97 to 1.23)	1.12 (1.01 to 1.24)	1.19 (1.04 to 1.35)
Velpatasvir 100 mg once daily	50 mg once daily	24	0.94 (0.86, 1.02)	0.91 (0.84, 0.98)	0.88 (0.82, 0.94)

^a The number of subjects represents the maximum number of subjects that were evaluated.

Table 12. Summary of Effect of Coadministered Drugs on the Pharmacokinetics of Dolutegravir

Coadministered Drug(s) and Dose(s)	Dose of TIVICAY	n	Geometric Mean Ratio (90% CI) of Dolutegravir Pharmacokinetic Parameters with/without Coadministered Drugs No Effect = 1.00		
			C _{max}	AUC	C _τ or C ₂₄
Atazanavir 400 mg once daily	30 mg once daily	12	1.50 (1.40 to 1.59)	1.91 (1.80 to 2.03)	2.80 (2.52 to 3.11)
Atazanavir/ritonavir 300/100 mg once daily	30 mg once daily	12	1.34 (1.25 to 1.42)	1.62 (1.50 to 1.74)	2.21 (1.97 to 2.47)
Darunavir/ritonavir 600/100 mg twice daily	30 mg once daily	15	0.89 (0.83 to 0.97)	0.78 (0.72 to 0.85)	0.62 (0.56 to 0.69)
Efavirenz 600 mg once daily	50 mg once daily	12	0.61 (0.51 to 0.73)	0.43 (0.35 to 0.54)	0.25 (0.18 to 0.34)
Elbasvir/grazoprevir 50/200 mg once daily	50 mg single dose	12	1.22 (1.05, 1.40)	1.16 (1.00, 1.34)	1.14 (0.95, 1.36)
Etravirine 200 mg twice daily	50 mg once daily	16	0.48 (0.43 to 0.54)	0.29 (0.26 to 0.34)	0.12 (0.09 to 0.16)
Etravirine + darunavir/ritonavir 200 mg + 600/100 mg twice daily	50 mg once daily	9	0.88 (0.78 to 1.00)	0.75 (0.69 to 0.81)	0.63 (0.52 to 0.76)
Etravirine + lopinavir/ritonavir 200 mg + 400/100 mg twice daily	50 mg once daily	8	1.07 (1.02 to 1.13)	1.11 (1.02 to 1.20)	1.28 (1.13 to 1.45)
Fosamprenavir/ritonavir 700 mg/100 mg twice daily	50 mg once daily	12	0.76 (0.63 to 0.92)	0.65 (0.54 to 0.78)	0.51 (0.41 to 0.63)
Lopinavir/ritonavir 400/100 mg twice daily	30 mg once daily	15	1.00 (0.94 to 1.07)	0.97 (0.91 to 1.04)	0.94 (0.85 to 1.05)
Rilpivirine 25 mg once daily	50 mg once daily	16	1.13 (1.06 to 1.21)	1.12 (1.05 to 1.19)	1.22 (1.15 to 1.30)
Tenofovir 300 mg once daily	50 mg once daily	15	0.97 (0.87 to 1.08)	1.01 (0.91 to 1.11)	0.92 (0.82 to 1.04)
Tipranavir/ritonavir 500/200 mg twice daily	50 mg once daily	14	0.54 (0.50 to 0.57)	0.41 (0.38 to 0.44)	0.24 (0.21 to 0.27)
Antacid (MAALOX) simultaneous administration	50 mg single dose	16	0.28 (0.23 to 0.33)	0.26 (0.22 to 0.32)	0.26 (0.21 to 0.31)
Antacid (MAALOX) 2 h after dolutegravir	50 mg single dose	16	0.82 (0.69 to 0.98)	0.74 (0.62 to 0.90)	0.70 (0.58 to 0.85)
Calcium carbonate 1,200 mg simultaneous administration (fasted)	50 mg single dose	12	0.63 (0.50 to 0.81)	0.61 (0.47 to 0.80)	0.61 (0.47 to 0.80)

Calcium carbonate 1,200 mg simultaneous administration (fed)	50 mg single dose	11	1.07 (0.83 to 1.38)	1.09 (0.84 to 1.43)	1.08 (0.81 to 1.42)
Calcium carbonate 1,200 mg 2 h after dolutegravir	50 mg single dose	11	1.00 (0.78 to 1.29)	0.94 (0.72 to 1.23)	0.90 (0.68 to 1.19)
Carbamazepine 300 mg twice daily	50 mg once daily	16 ^c	0.67 (0.61 to 0.73)	0.51 (0.48 to 0.55)	0.27 (0.24 to 0.31)
Daclatasvir 60 mg once daily	50 mg once daily	12	1.29 (1.07 to 1.57)	1.33 (1.11 to 1.59)	1.45 (1.25 to 1.68)
Ferrous fumarate 324 mg simultaneous administration (fasted)	50 mg single dose	11	0.43 (0.35 to 0.52)	0.46 (0.38 to 0.56)	0.44 (0.36 to 0.54)
Ferrous fumarate 324 mg simultaneous administration (fed)	50 mg single dose	11	1.03 (0.84 to 1.26)	0.98 (0.81 to 1.20)	1.00 (0.81 to 1.23)
Ferrous fumarate 324 mg 2 h after dolutegravir	50 mg single dose	10	0.99 (0.81 to 1.21)	0.95 (0.77 to 1.15)	0.92 (0.74 to 1.13)
Multivitamin (One-A-Day) simultaneous administration	50 mg single dose	16	0.65 (0.54 to 0.77)	0.67 (0.55 to 0.81)	0.68 (0.56 to 0.82)
Omeprazole 40 mg once daily	50 mg single dose	12	0.92 (0.75 to 1.11)	0.97 (0.78 to 1.20)	0.95 (0.75 to 1.21)
Prednisone 60 mg once daily with taper	50 mg once daily	12	1.06 (0.99 to 1.14)	1.11 (1.03 to 1.20)	1.17 (1.06 to 1.28)
Rifampin ^a 600 mg once daily	50 mg twice daily	11	0.57 (0.49 to 0.65)	0.46 (0.38 to 0.55)	0.28 (0.23 to 0.34)
Rifampin ^b 600 mg once daily	50 mg twice daily	11	1.18 (1.03 to 1.37)	1.33 (1.15 to 1.53)	1.22 (1.01 to 1.48)
Rifabutin 300 mg once daily	50 mg once daily	9	1.16 (0.98 to 1.37)	0.95 (0.82 to 1.10)	0.70 (0.57 to 0.87)

^a Comparison is rifampin taken with dolutegravir 50 mg twice daily compared with dolutegravir 50 mg twice daily.

^b Comparison is rifampin taken with dolutegravir 50 mg twice daily compared with dolutegravir 50 mg once daily.

^c The number of subjects represents the maximum number of subjects that were evaluated.

12.4 Microbiology

Mechanism of Action

Dolutegravir inhibits HIV integrase by binding to the integrase active site and blocking the strand transfer step of retroviral deoxyribonucleic acid (DNA) integration which is essential for the HIV replication cycle. Strand transfer biochemical assays using purified HIV-1 integrase and pre-processed substrate DNA resulted in IC₅₀ values of 2.7 nM and 12.6 nM.

Antiviral Activity in Cell Culture

Dolutegravir exhibited antiviral activity against laboratory strains of wild-type HIV-1 with mean EC₅₀ values of 0.5 nM (0.21 ng per mL) to 2.1 nM (0.85 ng per mL) in peripheral blood mononuclear cells (PBMCs) and MT-4 cells. Dolutegravir exhibited antiviral activity against 13 clinically diverse clade B isolates with a mean EC₅₀ value of 0.52 nM in a viral integrase susceptibility assay using the integrase coding region from clinical isolates. Dolutegravir demonstrated antiviral activity in cell culture against a panel of HIV-1 clinical isolates (3 in each group of M clades A, B, C, D, E, F, and G, and 3 in group O) with EC₅₀ values ranging from 0.02 nM to 2.14 nM for HIV-1. Dolutegravir EC₅₀ values against 3 HIV-2 clinical isolates in PBMC assays ranged from 0.09 nM to 0.61 nM.

Antiviral Activity in Combination with Other Antiviral Agents

The antiviral activity of dolutegravir was not antagonistic when combined with the INSTI, raltegravir; non-nucleoside reverse transcriptase inhibitors (NNRTIs), efavirenz or nevirapine; the NRTIs, abacavir or stavudine; the protease inhibitors (PIs), amprenavir or lopinavir; the CCR5 co-receptor antagonist, maraviroc; or the fusion inhibitor, enfuvirtide. Dolutegravir antiviral activity was not antagonistic when combined with the HBV reverse transcriptase inhibitor, adefovir, or inhibited by the antiviral, ribavirin.

Resistance

Cell Culture: Dolutegravir-resistant viruses were selected in cell culture starting from different wild-type HIV-1 strains and clades. Amino acid substitutions E92Q, G118R, S153F or Y, G193E or R263K emerged in different passages and conferred decreased susceptibility to dolutegravir of up to 4-fold. Passage of mutant viruses containing the Q148R or Q148H substitutions selected for additional substitutions in integrase that conferred decreased susceptibility to dolutegravir (fold-change increase of 13 to 46). The additional integrase substitutions included T97A, E138K, G140S, and M154I. Passage of mutant viruses containing both G140S and Q148H selected for L74M, E92Q, and N155H.

Treatment-Naïve Subjects: No subject who received dolutegravir 50-mg once-daily in the treatment-naïve trials SPRING-2 (96 weeks) and SINGLE (144 weeks) had a detectable decrease in susceptibility to dolutegravir or background NRTIs in the resistance analysis subset (n = 12 with HIV-1 RNA greater than 400 copies per mL at failure or last visit and having resistance data). Two virologic failure subjects in SINGLE had treatment-emergent G/D/E193D and G193G/E integrase substitutions at Week 84 and Week 108, respectively, and 1 subject with 275 copies per mL HIV-1 RNA had a treatment-emergent Q157Q/P integrase substitution detected at Week 24. None of these subjects had a corresponding decrease in dolutegravir susceptibility. No treatment-emergent genotypic resistance to the background regimen was observed in the dolutegravir arm in either the SPRING-2 or SINGLE trials. No treatment-emergent primary resistance substitutions were observed in either treatment group in the FLAMINGO trial through Week 96.

Treatment-Experienced, Integrase Strand Transfer Inhibitor-Naïve Subjects: In the dolutegravir arm of the SAILING trial for treatment-experienced and INSTI-naïve subjects (n = 354), treatment-emergent integrase substitutions were observed in 6 of 28 (21%) subjects who had virologic failure and resistance data. In 5 of the 6 subjects' isolates emergent INSTI substitutions included L74L/M/I, Q95Q/L, V151V/I (n = 1 each), and R263K (n = 2). The change in dolutegravir phenotypic susceptibility for these 5 subject isolates was less than 2-fold. One subject isolate had pre-existing raltegravir resistance substitutions E138A, G140S, and Q148H at baseline and had additional emergent INSTI-resistance substitutions T97A and E138A/T with a corresponding 148-fold reduction in dolutegravir susceptibility at failure. In the comparator raltegravir arm, 21 of 49 (43%) subjects with post-baseline resistance data had evidence of emergent INSTI-resistance substitutions (L74M, E92Q, T97A, E138Q, G140S/A, Y143R/C, Q148H/R, V151I, N155H, E157Q, and G163K/R) and raltegravir phenotypic resistance.

Virologically Suppressed Subjects: SWORD-1 and SWORD-2 are identical trials in virologically suppressed subjects receiving 2 NRTIs plus either an INSTI, an NNRTI, or a PI, that switched to dolutegravir plus rilpivirine (n = 513) or remained on their current antiviral regimen (n = 511). Two subjects in each treatment arm had confirmed virologic failure at any time through Week 48. The 2 subjects in the dolutegravir/rilpivirine arm had detectable resistance substitutions at rebound. One subject had the NNRTI-resistance-associated substitution K101K/E with no decreased susceptibility to rilpivirine (fold-change = 1.2) at Week 36, had no INSTI resistance-associated substitutions or decreased susceptibility to dolutegravir (fold-change less than 2), and had HIV-1 RNA less than 50 copies per mL at the withdrawal visit. The other subject had the dolutegravir resistance-associated substitution G193E at baseline (by exploratory HIV proviral DNA archive sequencing) and at Week 24 (by conventional sequencing) without decreased susceptibility to dolutegravir (fold-change = 1.02) at Week 24. No resistance-associated substitutions were observed for the other 2 subjects in the comparative current antiretroviral regimen arm.

Treatment-Experienced, Integrase Strand Transfer Inhibitor-Experienced Subjects: VIKING-3 examined the efficacy of dolutegravir 50 mg twice daily plus optimized background therapy in subjects with prior or current virologic failure on an INSTI- (elvitegravir or raltegravir) containing regimen. Use of TIVICAY in INSTI-experienced patients should be guided by the number and type of baseline INSTI substitutions. The efficacy of TIVICAY 50 mg twice daily is reduced in patients with an INSTI-resistance Q148 substitution plus 2 or more additional INSTI-resistance substitutions, including T66A, L74I/M, E138A/K/T, G140S/A/C, Y143R/C/H, E157Q, G163S/E/K/Q, or G193E/R.

Response by Baseline Genotype

Of the 183 subjects with baseline data, 30% harbored virus with a substitution at Q148, and 33% had no primary INSTI-resistance substitutions (T66A/I/K, E92Q/V, Y143R/C/H, Q148H/R/K, and N155H) at baseline, but had historical genotypic evidence of INSTI-resistance substitutions,

phenotypic evidence of elvitegravir or raltegravir resistance, or genotypic evidence of INSTI-resistance substitutions at screening.

Response rates by baseline genotype were analyzed in an “as-treated” analysis at Week 48 (n = 175) (Table 13). The response rate at Week 48 to dolutegravir-containing regimens was 47% (24 of 51) when Q148 substitutions were present at baseline; Q148 was always present with additional INSTI-resistance substitutions (Table 13). In addition, a diminished virologic response of 40% (6 of 15) was observed when the substitution E157Q or K was present at baseline with other INSTI-resistance substitutions but without a Q148H or R substitution.

Table 13. Response by Baseline Integrase Genotype in Subjects with Prior Experience to an Integrase Strand Transfer Inhibitor in VIKING-3

Baseline Genotype	Week 48 (<50 copies/mL) n = 175
Overall Response	66% (116/175)
No Q148 substitution ^a	74% (92/124)
Q148H/R + G140S/A/C without additional INSTI-resistance substitution ^b	61% (17/28)
Q148H/R + ≥2 INSTI-resistance substitutions ^{b,c}	29% (6/21)

^a Includes INSTI-resistance substitutions Y143R/C/H and N155H.

^b INSTI-resistance substitutions included T66A, L74I/M, E138A/K/T, G140S/A/C, Y143R/C/H, E157Q, G163S/E/K/Q, or G193E/R. Two additional subjects had baseline genotypes of Q148Q/R plus L74L/I/M (virologic failure) and Q148R plus E138K (responder).

^c The most common pathway with Q148H/R + greater than or equal to 2 INSTI-resistance substitutions had Q148+G140+E138 substitutions (n = 16).

Response by Baseline Phenotype

Response rates by baseline phenotype were analyzed in an as-treated analysis using all subjects with available baseline phenotypes through Week 48 (n = 163) (Table 14). These baseline phenotypic groups are based on subjects enrolled in VIKING-3 and are not meant to represent definitive clinical susceptibility cut points for dolutegravir. The data are provided to guide clinicians on the likelihood of virologic success based on pretreatment susceptibility to dolutegravir in INSTI-resistant patients.

Table 14. Response by Baseline Dolutegravir Phenotype (Fold-Change from Reference) in Subjects with Prior Experience to an Integrase Strand Transfer Inhibitor in VIKING-3

Baseline Dolutegravir Phenotype (Fold-Change from Reference)	Response at Week 48 (<50 copies/mL) Subset n = 163
Overall Response	64% (104/163)
<3-fold change	72% (83/116)
3- <10-fold change	53% (18/34)
≥10-fold change	23% (3/13)

Integrase Strand Transfer Inhibitor Treatment-Emergent Resistance

There were 50 subjects with virologic failure on the dolutegravir twice-daily regimen in VIKING-3 with HIV-1 RNA greater than 400 copies per mL at the failure timepoint, Week 48 or beyond, or the last timepoint on trial. Thirty-nine subjects with virologic failure had resistance data that were used in the Week 48 analysis. In the Week 48 resistance analysis 85% (33 of 39) of the subjects with virologic failure had treatment-emergent INSTI-resistance substitutions in their isolates. The most common treatment-emergent INSTI-resistance substitution was T97A. Other frequently emergent INSTI-resistance substitutions included L74M, I or V, E138K or A, G140S, Q148H, R or K, M154I, or N155H. Substitutions E92Q, Y143R or C/H, S147G, V151A, and E157E/Q each emerged in 1 to 3 subjects' isolates. At failure, the median dolutegravir fold-change from reference was 61-fold (range: 0.75 to 209) for isolates with emergent INSTI-resistance substitutions (n = 33).

Resistance to one or more background drugs in the dolutegravir twice-daily regimen also emerged in 49% (19 of 39) of subjects in the Week 48 resistance analysis.

In VIKING-4 (ING116529), 30 subjects with current virological failure on an INSTI-containing regimen and genotypic evidence of INSTI-resistance substitutions at screening were randomized to receive either dolutegravir 50 mg twice daily or placebo with the current failing regimen for 7 days and then all subjects received open-label dolutegravir plus optimized background regimen from Day 8. Virologic responses at Week 48 by baseline genotypic and phenotypic INSTI-resistance categories and the INSTI resistance-associated substitutions that emerged on dolutegravir treatment in VIKING-4 were consistent with those seen in VIKING-3.

Cross-Resistance

Site-Directed Integrase Strand Transfer Inhibitor-Resistant Mutant HIV-1 and HIV-2 Strains:

The susceptibility of dolutegravir was tested against 60 INSTI-resistant site-directed mutant HIV-1 viruses (28 with single substitutions and 32 with 2 or more substitutions) and 6 INSTI-resistant site-directed mutant HIV-2 viruses. The single INSTI-resistance substitutions T66K, I151L, and S153Y conferred a greater than 2-fold decrease in dolutegravir susceptibility (range: 2.3-fold to 3.6-fold from reference). Combinations of multiple substitutions T66K/L74M,

E92Q/N155H, G140C/Q148R, G140S/Q148H, R or K, Q148R/N155H, T97A/G140S/Q148, and substitutions at E138/G140/Q148 showed a greater than 2-fold decrease in dolutegravir susceptibility (range: 2.5-fold to 21-fold from reference). In HIV-2 mutants, combinations of substitutions A153G/N155H/S163G and E92Q/T97A/N155H/S163D conferred 4-fold decreases in dolutegravir susceptibility, and E92Q/N155H and G140S/Q148R showed 8.5-fold and 17-fold decreases in dolutegravir susceptibility, respectively.

Reverse Transcriptase Inhibitor- and Protease Inhibitor-Resistant Strains: Dolutegravir demonstrated equivalent antiviral activity against 2 NNRTI-resistant, 3 NRTI-resistant, and 2 PI-resistant HIV-1 mutant clones compared with the wild-type strain.

13 NONCLINICAL TOXICOLOGY

13.1 Carcinogenesis, Mutagenesis, Impairment of Fertility

Carcinogenesis

Two-year carcinogenicity studies in mice and rats were conducted with dolutegravir. Mice were administered doses of up to 500 mg per kg, and rats were administered doses of up to 50 mg per kg. In mice, no significant increases in the incidence of drug-related neoplasms were observed at the highest doses tested, resulting in dolutegravir AUC exposures approximately 14 times higher than those in humans at the maximum recommended dose. In rats, no increases in the incidence of drug-related neoplasms were observed at the highest dose tested, resulting in dolutegravir AUC exposures 10 times and 15 times higher in males and females, respectively, than those in humans at the maximum recommended dose.

Mutagenesis

Dolutegravir was not genotoxic in the bacterial reverse mutation assay, mouse lymphoma assay, or in the in vivo rodent micronucleus assay.

Impairment of Fertility

In a study conducted in rats, there were no effects on mating or fertility with dolutegravir up to 1,000 mg per kg per day. This dose is associated with an exposure that is approximately 24 times higher than the exposure in humans at the maximum recommended dose.

14 CLINICAL STUDIES

14.1 Description of Clinical Studies

The efficacy and safety of TIVICAY or TIVICAY PD were evaluated in the studies summarized in Table 15.

Table 15. Trials Conducted with TIVICAY or TIVICAY PD in HIV-1–Infected Subjects

Population	Trial	Trial Arms	Timepoint (Week)
Adults: Treatment-naïve	SPRING-2 (ING113086) (NCT01227824)	TIVICAY + 2 NRTIs (n = 403) Raltegravir + 2 NRTIs (n = 405)	96
	SINGLE (ING114467) (NCT01263015)	TIVICAY + EPZICOM (n = 414) ATRIPLA (n = 419)	144
	FLAMINGO (ING114915) (NCT01449929)	TIVICAY + NRTI BR (n = 243) Darunavir/ritonavir + NRTI BR (n = 242)	96
Treatment-experienced, INSTI-naïve	SAILING (ING111762) (NCT01231516)	TIVICAY + BR (n = 354) Raltegravir + BR (n = 361)	48
INSTI-experienced	VIKING-3 (ING112574) (NCT01328041)	TIVICAY + OBT (n = 183)	48
Virologically suppressed	SWORD-1 (NCT02429791) SWORD-2 (NCT02422797)	Pooled presentation TIVICAY + Rilpivirine (n = 513) CAR (n = 511)	48
Pediatrics: 4 weeks and older and weighing at least 3 kg without INSTI resistance	IMPAACT P1093 (NCT01302847)	TIVICAY or TIVICAY PD + BR (n = 75)	24

BR = Background regimen; CAR = Current antiretroviral regimen; OBT = Optimized background therapy.

14.2 Adult Subjects

Treatment-Naïve Subjects

In SPRING-2, 822 subjects were randomized and received at least 1 dose of either TIVICAY 50 mg once daily or raltegravir 400 mg twice daily, both in combination with fixed-dose dual NRTI treatment (either abacavir sulfate and lamivudine [EPZICOM] or emtricitabine/tenofovir [TRUVADA]). There were 808 subjects included in the efficacy and safety analyses. At baseline, the median age of subjects was 36 years, 13% female, 15% non-white, 11% had hepatitis B and/or C virus co-infection, 2% were CDC Class C (AIDS), 28% had HIV-1 RNA greater than 100,000 copies per mL, 48% had CD4+ cell count less than 350 cells per mm³, and 39% received EPZICOM; these characteristics were similar between treatment groups.

In SINGLE, 833 subjects were randomized and received at least 1 dose of either TIVICAY 50 mg once daily with fixed-dose abacavir sulfate and lamivudine (EPZICOM) or fixed-dose

efavirenz/emtricitabine/tenofovir (ATRIPLA). At baseline, the median age of subjects was 35 years, 16% female, 32% non-white, 7% had hepatitis C co-infection (hepatitis B virus co-infection was excluded), 4% were CDC Class C (AIDS), 32% had HIV-1 RNA greater than 100,000 copies per mL, and 53% had CD4+ cell count less than 350 cells per mm³; these characteristics were similar between treatment groups.

Outcomes for SPRING-2 (Week 96 analysis) and SINGLE (Week 144 open-label phase analysis which followed the Week 96 double-blind phase) are provided in Table 16. Side-by-side tabulation is to simplify presentation; direct comparisons across trials should not be made due to differing trial designs.

Table 16. Virologic Outcomes of Randomized Treatment in SPRING-2 at Week 96 and SINGLE at Week 144 (Snapshot Algorithm)

	SPRING-2 Week 96		SINGLE Week 144	
	TIVICAY 50 mg Once Daily + 2 NRTIs (n = 403)	Raltegravir 400 mg Twice Daily + 2 NRTIs (n = 405)	TIVICAY 50 mg + EPZICOM Once Daily (n = 414)	ATRIPLA Once Daily (n = 419)
HIV-1 RNA <50 copies/mL	82%	78%	71%	63%
Treatment difference ^a	4.9% (95% CI: -0.6%, 10.3%) ^d		8.3% (95% CI: 2.0%, 14.6%) ^c	
Virologic nonresponse	5%	10%	10%	7%
Data in window not <50 copies/mL	1%	3%	4%	<1%
Discontinued for lack of efficacy	2%	3%	3%	3%
Discontinued for other reasons while not suppressed	<1%	3%	3%	4%
Change in ART regimen	<1%	<1%	0	0
No virologic data	12%	12%	18%	30%
Reasons				
Discontinued study/study drug due to adverse event or death ^b	2%	2%	4%	14%
Discontinued study/study drug for other reasons ^c	8%	9%	12%	13%
Missing data during window but on study	2%	<1%	2%	3%

Proportion (%) of Subjects with HIV-1 RNA <50 copies/mL by Baseline Category				
Plasma viral load (copies/mL)				
≤100,000	84%	83%	73%	64%
>100,000	79%	63%	69%	61%
Gender				
Male	84%	79%	72%	66%
Female	70%	68%	69%	48%
Race				
White	83%	78%	72%	71%
African-American/African Heritage/Other	77%	75%	71%	47%

^a Adjusted for pre-specified stratification factors.

^b Includes subjects who discontinued due to an adverse event or death at any time point if this resulted in no virologic data on treatment during the analysis window.

^c Other includes reasons such as withdrew consent, loss to follow-up, moved, and protocol deviation.

^d The primary endpoint was assessed at Week 48 and the virologic success rate was 88% in the group receiving TIVICAY and 86% in the raltegravir group, with a treatment difference of 2.6% and 95% CI of (-1.9%, 7.2%).

^e The primary endpoint was assessed at Week 48 and the virologic success rate was 88% in the group receiving TIVICAY and 81% in the ATRIPLA group, with a treatment difference of 7.4% and 95% CI of (2.5%, 12.3%).

SPRING-2: Virologic outcomes were also comparable across baseline characteristics including CD4+ cell count, age, and use of EPZICOM or TRUVADA as NRTI background regimen. The median change in CD4+ cell counts from baseline was 276 cells per mm³ in the group receiving TIVICAY and 264 cells per mm³ for the raltegravir group at 96 weeks.

There was no treatment-emergent resistance to dolutegravir or to the NRTI background.

SINGLE: Treatment differences were maintained across baseline characteristics including baseline viral load, CD4+ cell count, age, gender, and race.

The adjusted mean changes in CD4+ cell counts from baseline were 378 cells per mm³ in the group receiving TIVICAY + EPZICOM and 332 cells per mm³ for the ATRIPLA group at 144 weeks. The adjusted difference between treatment arms and 95% CI was 46.9 cells per mm³ (15.6 cells per mm³, 78.2 cells per mm³) (adjusted for pre-specified stratification factors: baseline HIV-1 RNA, and baseline CD4+ cell count).

There was no treatment-emergent resistance to dolutegravir, abacavir, or lamivudine.

FLAMINGO: In FLAMINGO, 485 subjects were randomized and received at least 1 dose of either TIVICAY 50 mg once daily (n = 243) or darunavir + ritonavir 800 mg/100 mg once daily

(n = 242), both in combination with investigator-selected NRTI background regimen (either fixed-dose abacavir and lamivudine [EPZICOM] or fixed-dose emtricitabine/tenofovir disoproxil fumarate [TRUVADA]). There were 484 subjects included in the efficacy and safety analyses. At baseline, the median age of subjects was 34 years, 15% female, 28% non-white, 10% had hepatitis B and/or C virus co-infection, 3% were CDC Class C (AIDS), 25% had HIV-1 RNA greater than 100,000 copies per mL, and 35% had CD4+ cell count less than 350 cells per mm³; these characteristics were similar between treatment groups. Overall response rates by Snapshot algorithm through Week 96 were 80% for TIVICAY and 68% for darunavir/ritonavir. The proportion of subjects who were non-responders (HIV-1 RNA greater than or equal to 50 copies per mL) at Week 96 was 8% and 12% in the arms receiving TIVICAY and darunavir + ritonavir, respectively; no virologic data were available for 12% and 21% for subjects treated with TIVICAY and darunavir + ritonavir, respectively. The adjusted overall response rate difference in proportion and 95% CI was 12.4% (4.7%, 20.2%). No treatment-emergent primary resistance substitutions were observed in either treatment group.

Treatment-Experienced, Integrase Strand Transfer Inhibitor-Naïve Subjects

In the international, multicenter, double-blind trial (SAILING), 719 HIV-1–infected, antiretroviral treatment-experienced adults were randomized and received either TIVICAY 50 mg once daily or raltegravir 400 mg twice daily with investigator-selected background regimen consisting of up to 2 agents, including at least 1 fully active agent. There were 715 subjects included in the efficacy and safety analyses. At baseline, the median age was 43 years, 32% were female, 50% non-white, 16% had hepatitis B and/or C virus co-infection, 46% were CDC Class C (AIDS), 20% had HIV-1 RNA greater than 100,000 copies per mL, and 72% had CD4+ cell count less than 350 cells per mm³; these characteristics were similar between treatment groups. All subjects had at least 2-class antiretroviral treatment resistance, and 49% of subjects had at least 3-class antiretroviral treatment resistance at baseline. Week 48 outcomes for SAILING are shown in Table 17.

Table 17. Virologic Outcomes of Randomized Treatment in SAILING at 48 Weeks (Snapshot Algorithm)

	TIVICAY 50 mg Once Daily + BR^a (n = 354)	Raltegravir 400 mg Twice Daily + BR^a (n = 361)
HIV-1 RNA <50 copies/mL	71%	64%
Adjusted ^b treatment difference	7.4% (95% CI: 0.7%, 14.2%)	
Virologic nonresponse	20%	28%
No virologic data	9%	9%
Reasons		
Discontinued study/study drug due to adverse event or death	3%	4%
Discontinued study/study drug for other reasons ^c	5%	4%

Missing data during window but on study	2%	1%
Proportion (%) with HIV-1 RNA <50 copies/mL by Baseline Category		
Plasma viral load (copies/mL)		
≤50,000 copies/mL	75%	71%
>50,000 copies/mL	62%	47%
Background regimen		
No darunavir use	67%	60%
Darunavir use with primary PI substitutions	85%	67%
Darunavir use without primary PI substitutions	69%	70%
Gender		
Male	70%	66%
Female	74%	60%
Race		
White	75%	71%
African-American/African Heritage/Other	67%	57%

^a BR = Background regimen. Background regimen was restricted to less than or equal to 2 antiretroviral treatments with at least 1 fully active agent.

^b Adjusted for pre-specified stratification factors.

^c Other includes reasons such as withdrew consent, loss to follow-up, moved, and protocol deviation.

Treatment differences were maintained across the baseline characteristics including CD4+ cell count and age.

The mean changes in CD4+ cell counts from baseline were 162 cells per mm³ in the group receiving TIVICAY and 153 cells per mm³ in the raltegravir group.

Treatment-Experienced, Integrase Strand Transfer Inhibitor-Experienced Subjects

VIKING-3 examined the effect of TIVICAY 50 mg twice daily over 7 days of functional monotherapy, followed by OBT with continued treatment of TIVICAY 50 mg twice daily.

In the multicenter, open-label, single-arm VIKING-3 trial, 183 HIV-1–infected, antiretroviral treatment-experienced adults with virological failure and current or historical evidence of raltegravir and/or elvitegravir resistance received TIVICAY 50 mg twice daily with the current failing background regimen for 7 days, then received TIVICAY with OBT from Day 8. A total of 183 subjects enrolled: 133 subjects with INSTI resistance at screening and 50 subjects with only historical evidence of resistance (and not at screening). At baseline, median age of subjects was 48 years; 23% were female, 29% non-white, and 20% had hepatitis B and/or C virus co-infection. Median baseline CD4+ cell count was 140 cells per mm³, median duration of prior antiretroviral treatment was 13 years, and 56% were CDC Class C. Subjects showed multiple-class antiretroviral treatment resistance at baseline: 79% had greater than or equal to 2 NRTI, 75% greater than or equal to 1 NNRTI, and 71% greater than or equal to 2 PI major substitutions; 62% had non-R5 virus.

Mean reduction from baseline in HIV-1 RNA at Day 8 (primary endpoint) was 1.4 log₁₀ (95% CI: 1.3 log₁₀, 1.5 log₁₀). Response at Week 48 was affected by baseline INSTI substitutions [see *Microbiology (12.4)*].

After the functional monotherapy phase, subjects had the opportunity to re-optimize their background regimen when possible. Week 48 virologic outcomes for VIKING-3 are shown in Table 18.

Table 18. Virologic Outcomes of Treatment of VIKING-3 at 48 Weeks (Snapshot Algorithm)

	TIVICAY 50 mg Twice Daily + OBT (n = 183)
HIV-1 RNA <50 copies/mL	63%
Virologic nonresponse	32%
No virologic data	
Reasons	
Discontinued study/study drug due to adverse event or death	3%
Proportion (%) with HIV-1 RNA <50 copies/mL by Baseline Category	
Gender	
Male	63%
Female	64%
Race	
White	63%
African-American/African Heritage/Other	64%

Subjects harboring virus with Q148 and with additional Q148-associated secondary substitutions also had a reduced response at Week 48 in a stepwise fashion [see *Microbiology (12.4)*].

The median change in CD4+ cell count from baseline was 80 cells per mm³ at Week 48.

Virologically Suppressed Subjects

SWORD-1 and SWORD-2 are identical 148-week, Phase 3, randomized, multicenter, parallel-group, non-inferiority trials. A total of 1,024 adult HIV-1–infected subjects who were on a stable suppressive antiretroviral regimen (containing 2 NRTIs plus either an INSTI, an NNRTI, or a PI) for at least 6 months (HIV-1 RNA less than 50 copies per mL), with no history of treatment failure and no known substitutions associated with resistance to dolutegravir or rilpivirine received treatment in the trials. Subjects were randomized 1:1 to continue their current antiretroviral regimen or be switched to TIVICAY 50 mg plus rilpivirine 25 mg administered once daily. The primary efficacy endpoint for the SWORD trial was the proportion of subjects with plasma HIV-1 RNA less than 50 copies per mL at Week 48. The proportion of subjects with HIV-1 RNA less than 50 copies per mL at Week 48 was 95% for both treatment groups; treatment difference and 95% CI was -0.2% (-3.0%, 2.5%). The proportion of subjects with

HIV-1 RNA greater than or equal to 50 copies per mL (virologic failure) at Week 48 was 0.6% and 1.2% for the dolutegravir plus rilpivirine treatment group and the current antiretroviral regimen treatment groups, respectively; treatment difference and 95% CI was -0.6% (-1.7%, 0.6%). Refer to the prescribing information for JULUCA (dolutegravir and rilpivirine) tablet for complete virologic outcome information.

14.3 Pediatric Subjects

IMPAACT P1093 is an ongoing Phase 1/2, multicenter, open-label trial to evaluate the pharmacokinetic parameters, safety, tolerability, and efficacy of TIVICAY or TIVICAY PD in combination treatment regimens in HIV-1–infected infants, children, and adolescents aged at least 4 weeks to 18 years. Subjects were stratified by 5 age cohorts: Cohort 1, aged 12 to less than 18 years; Cohort 2A, aged 6 to less than 12 years; Cohort 3, aged 2 to less than 6 years; Cohort 4, aged 6 months to less than 2 years; and Cohort 5, aged 4 weeks to less than 6 months. Seventy-five subjects received the recommended dose (determined by weight and age) of TIVICAY or TIVICAY PD [*see Dosage and Administration (2.3, 2.4, 2.5)*].

These 75 subjects had a median age of 27 months (range: 1 to 214), were 59% female, and 68% were black or African American. At baseline, mean plasma HIV-1 RNA was 4.4 log₁₀ copies per mL, median CD4+ cell count was 1,225 cells per mm³ (range: 1 to 8,255), and median CD4+% was 23% (range: 0.3% to 49%). Overall, 33% had baseline plasma HIV-1 RNA greater than 50,000 copies per mL and 12% had a CDC HIV clinical classification of category C. The majority (80%) of subjects were treatment-experienced, but all were INSTI-naïve. Most subjects had previously used at least 1 NNRTI (44%) or 1 PI (76%).

Virologic outcomes from IMPAACT P1093 include subjects who received either TIVICAY tablets or TIVICAY PD tablets for oral suspension as per the dosing recommendations for their weight band and who had reached Week 24 (n = 58) or Week 48 (n = 42). At Week 24, 62% of subjects achieved HIV-1 RNA less than 50 copies per mL and 86% achieved HIV-1 RNA less than 400 copies per mL (Snapshot algorithm). The median CD4 count (percent) increase from baseline to Week 24 was 105 cells per mm³ (5%). At Week 48, 69% of subjects achieved HIV-1 RNA less than 50 copies per /mL and 79% achieved HIV-1 RNA less than 400 copies per mL (Snapshot algorithm). The median CD4 count (percent) increase from baseline to Week 48 was 141 cells per mm³ (7%).

16 HOW SUPPLIED/STORAGE AND HANDLING

TIVICAY tablets, 10 mg, are white, round, film-coated, biconvex tablets debossed with “SV 572” on one side and “10” on the other side. Bottle of 30 tablets with child-resistant closure and containing a desiccant. NDC 49702-226-13.

Store and dispense the 10-mg tablets in the original package, protect from moisture, and keep the bottle tightly closed. Do not remove desiccant.

TIVICAY tablets, 25 mg, are pale yellow, round, film-coated, biconvex tablets debossed with “SV 572” on one side and “25” on the other side. Bottle of 30 tablets with child-resistant closure. NDC 49702-227-13.

TIVICAY tablets, 50 mg, are yellow, round, film-coated, biconvex tablets debossed with “SV 572” on one side and “50” on the other side. Bottle of 30 tablets with child-resistant closure. NDC 49702-228-13.

Store TIVICAY tablets at 25°C (77°F); excursions permitted 15° to 30°C (59° to 86°F) [See USP Controlled Room Temperature].

TIVICAY PD tablets for oral suspension, 5 mg, are white, round, strawberry cream flavored, film-coated, biconvex tablets debossed with “SV H7S” on one side and “5” on the other side. Bottle of 60 tablets with child-resistant closure containing a desiccant. Each bottle is packaged with one 30-mL dosing cup and one 10-mL oral dosing syringe with 1-mL gradations. NDC 49702-255-37.

Store TIVICAY PD tablets for oral suspension below 30°C (86°F). Store and dispense the 5-mg tablets in the original bottle, protect from moisture, and keep the bottle tightly closed. Do not remove desiccant.

17 PATIENT COUNSELING INFORMATION

Advise the patient to read the FDA-approved patient labeling (Patient Information and Instructions for Use).

Drug Interactions

TIVICAY or TIVICAY PD may interact with other drugs; therefore, advise patients to report to their healthcare provider the use of any other prescription or nonprescription medication or herbal products, including St. John’s wort [*see Contraindications (4), Drug Interactions (7)*].

Hypersensitivity Reactions

Advise patients to immediately contact their healthcare provider if they develop rash. Instruct patients to immediately stop taking TIVICAY or TIVICAY PD and other suspect agents, and seek medical attention if they develop a rash associated with any of the following symptoms, as it may be a sign of a more serious reaction such as severe hypersensitivity: fever; generally ill feeling; extreme tiredness; muscle or joint aches; blisters or peeling of the skin; oral blisters or lesions; eye inflammation; facial swelling; swelling of the eyes, lips, tongue, or mouth; breathing difficulty; and/or signs and symptoms of liver problems (e.g., yellowing of the skin or whites of the eyes, dark or tea-colored urine, pale-colored stools or bowel movements, nausea, vomiting, loss of appetite, or pain, aching, or sensitivity on the right side below the ribs) [*see Warnings and Precautions (5.1)*].

Hepatotoxicity

Inform patients that hepatotoxicity has been reported with dolutegravir [*see Warnings and Precautions (5.2)*]. Advise patients that laboratory monitoring for hepatotoxicity during therapy with TIVICAY or TIVICAY PD is recommended, especially for patients with liver disease, such as hepatitis B or C.

Embryo-Fetal Toxicity

Advise adolescents and adults of childbearing potential to consider an alternative treatment to dolutegravir at the time of conception through the first trimester of pregnancy. Advise adolescents and adults of childbearing potential to contact their healthcare provider if they plan to become pregnant, become pregnant, or if pregnancy is suspected during treatment with dolutegravir [*see Warnings and Precaution (5.3), Use in Specific Populations (8.1, 8.3)*].

Counsel adolescents and adults of childbearing potential taking dolutegravir to consistently use effective contraception [*see Warnings and Precautions (5.3), Use in Specific Populations (8.1, 8.3)*].

Immune Reconstitution Syndrome

Advise patients to inform their healthcare provider immediately of any signs or symptoms of infection as inflammation from previous infection may occur soon after combination antiretroviral therapy, including when TIVICAY or TIVICAY PD is started [*see Warnings and Precautions (5.5)*].

Different Formulations Are Not Bioequivalent

Advise patients that TIVICAY and TIVICAY PD are not bioequivalent and are not interchangeable on a milligram-per-milligram basis. Advise patients or their care provider that patients switching from one formulation to the other must adjust the dose for the new dosage formulation [*see Dosage and Administration (2.3) and Warnings and Precautions (5.6)*].

Pregnancy Registry

Inform patients that there is an antiretroviral pregnancy registry to monitor fetal outcomes in those exposed to TIVICAY or TIVICAY PD during pregnancy [*see Use in Specific Populations (8.1)*].

Lactation

Instruct mothers with HIV-1 infection not to breastfeed because HIV-1 can be passed to the baby in the breast milk [*see Use in Specific Populations (8.2)*].

Administration Instructions

To avoid a dosing error from using the wrong formulation of dolutegravir, strongly advise patients and caregivers to visually inspect the tablets to verify the correct formulation each time

the prescription is filled [*see Dosage and Administration (2), Warnings and Precautions (5.6), How Supplied/Storage and Handling (16)*].

Inform patients and caregivers that TIVICAY PD tablets for oral suspension may be swallowed whole or dispersed in drinking water and should not be chewed, cut or crushed. The amount of water needed to disperse the tablet will depend on the dose (number of tablets prescribed).

Instruct patients and caregivers that if a dose of TIVICAY or TIVICAY PD is missed, to take it as soon as they remember. Advise patients and caregivers not to double the next dose or take more than the prescribed dose [*see Dosage and Administration (2)*].

Storage

Instruct patients and caregivers to store the TIVICAY 10-mg tablets and TIVICAY PD 5-mg tablets for oral suspension in the original package, keep the bottle tightly closed, and protect from moisture. Do not remove desiccant [*see How Supplied/Storage and Handling (16)*].

TIVICAY, TIVICAY PD, EPZICOM, JULUCA, and TRIUMEQ are trademarks owned by or licensed to the ViiV Healthcare group of companies.

The other brands listed are trademarks owned by or licensed to their respective owners and are not owned by or licensed to the ViiV Healthcare group of companies. The makers of these brands are not affiliated with and do not endorse the ViiV Healthcare group of companies or its products.

Manufactured for:



ViiV Healthcare
Research Triangle Park, NC 27709

by:
GlaxoSmithKline
Research Triangle Park, NC 27709

©2020 ViiV Healthcare group of companies or its licensor.
TVC:xxPI

PHARMACIST-DETACH HERE AND GIVE INSTRUCTIONS TO PATIENT

PATIENT INFORMATION	
TIVICAY (TIV-eh-kay) (dolutegravir) tablets	TIVICAY PD (TIV-eh-kay Pe De) (dolutegravir) tablets for oral suspension
<p>What is TIVICAY and TIVICAY PD?</p> <p>TIVICAY and TIVICAY PD are prescription medicines used to treat Human Immunodeficiency Virus-1 (HIV-1) infection together with:</p> <ul style="list-style-type: none">• other HIV-1 medicines in adults who have not received HIV-1 medicines in the past or to replace their current HIV-1 medicines.• other HIV-1 medicines in children, aged at least 4 weeks and weighing at least 6.6 pounds (3 kg), who have not received HIV-1 medicines in the past or to replace their current HIV-1 medicines when their healthcare provider determines that they meet certain requirements. <p>TIVICAY is used together with rilpivirine as a complete regimen to treat Human Immunodeficiency Virus-1 (HIV-1) infection in adults to replace their current HIV-1 medicines when their healthcare provider determines that they meet certain requirements.</p> <p>HIV-1 is the virus that causes Acquired Immune Deficiency Syndrome (AIDS).</p> <p>It is not known if TIVICAY or TIVICAY PD is safe and effective in children who are less than 4 weeks of age and weigh less than 6.6 pounds (3 kg) or in children who have received certain types of medicine for HIV-1 infection.</p>	
<p>Do not take TIVICAY or TIVICAY PD if you:</p> <ul style="list-style-type: none">• have ever had an allergic reaction to a medicine that contains dolutegravir.• take dofetilide.	
<p>Before you take TIVICAY or TIVICAY PD, tell your healthcare provider about all of your medical conditions, including if you:</p> <ul style="list-style-type: none">• have or have had liver problems, including hepatitis B or C infection.• are pregnant or plan to become pregnant. TIVICAY or TIVICAY PD may harm your unborn baby.<ul style="list-style-type: none">○ Your healthcare provider may prescribe a different medicine than TIVICAY or TIVICAY PD if you are planning to become pregnant or if pregnancy is confirmed during the first 12 weeks of pregnancy○ If you can become pregnant, your healthcare provider will perform a pregnancy test before you start treatment with TIVICAY or TIVICAY PD.○ If you can become pregnant, you should consistently use effective birth control (contraception) during treatment with TIVICAY or TIVICAY PD.○ Tell your healthcare provider right away if you are planning to become pregnant, you become pregnant, or think you may be pregnant during treatment with TIVICAY or TIVICAY PD.	

Pregnancy Registry. There is a pregnancy registry for individuals who take antiretroviral medicines, including TIVICAY and TIVICAY PD, during pregnancy. The purpose of this registry is to collect information about the health of you and your baby. Talk with your healthcare provider about how you can take part in this registry.

- are breastfeeding or plan to breastfeed. **Do not breastfeed if you take TIVICAY or TIVICAY PD.**
 - You should not breastfeed if you have HIV-1 because of the risk of passing HIV-1 to your baby.
 - It is not known if TIVICAY or TIVICAY PD can pass to your baby in your breast milk.Talk with your healthcare provider about the best way to feed your baby.

Tell your healthcare provider about all the medicines you take, including prescription and over-the-counter medicines, vitamins, and herbal supplements.

Some medicines interact with TIVICAY or TIVICAY PD. Keep a list of your medicines and show it to your healthcare provider and pharmacist when you get a new medicine.

- You can ask your healthcare provider or pharmacist for a list of medicines that interact with TIVICAY or TIVICAY PD.
- **Do not start taking a new medicine without telling your healthcare provider.** Your healthcare provider can tell you if it is safe to take TIVICAY or TIVICAY PD with other medicines.

How should I take TIVICAY or TIVICAY PD?

- **Take TIVICAY or TIVICAY PD exactly as your healthcare provider tells you to take it.**
- Take TIVICAY or TIVICAY PD with or without food.
- For children who cannot swallow tablets, read the Instructions for Use at the end of this patient information for detailed instructions on how to prepare a dose of TIVICAY PD tablets for oral suspension.
- TIVICAY PD may be swallowed whole or dispersed in drinking water and should not be chewed, cut, or crushed.
- **TIVICAY tablets are not the same as TIVICAY PD tablets for oral suspension and cannot be substituted for each other. Check to make sure you receive the correct form of TIVICAY each time you or your child's prescription is filled to avoid using the wrong medicine.**
- Do not change your dose, switch medicines or stop taking TIVICAY or TIVICAY PD without talking with your healthcare provider first.
- If you take antacids, laxatives, or other medicines that contain aluminum, magnesium, or buffered medicines, TIVICAY or TIVICAY PD should be taken at least 2 hours before or 6 hours after you take these medicines.
- If you need to take iron or calcium supplements by mouth during treatment with TIVICAY or TIVICAY PD:
 - If you take TIVICAY with food, you may take these supplements at the same time that you take TIVICAY.
 - If you do not take TIVICAY or TIVICAY PD with food, take TIVICAY or TIVICAY PD at least 2 hours before or 6 hours after you take these supplements.
- Do not miss a dose of TIVICAY or TIVICAY PD.

- If you miss a dose of TIVICAY or TIVICAY PD, take it as soon as you remember. Do not take 2 doses at the same time or take more than your prescribed dose.
- Stay under the care of a healthcare provider during treatment with TIVICAY or TIVICAY PD.
- Do not run out of TIVICAY or TIVICAY PD. The virus in your blood may increase and the virus may become harder to treat. When your supply starts to run low, get more from your healthcare provider or pharmacy.
- If you take too much TIVICAY or TIVICAY PD, call your healthcare provider or go to the nearest hospital emergency room right away.

What are the possible side effects of TIVICAY or TIVICAY PD?

- **TIVICAY or TIVICAY PD can cause serious side effects including:**
- **Allergic reactions.** Call your healthcare provider right away if you develop a rash with TIVICAY or TIVICAY PD. **Stop taking TIVICAY or TIVICAY PD and get medical help right away if you develop a rash with any of the following signs or symptoms:**
 - fever
 - generally ill feeling
 - tiredness
 - muscle or joint aches
 - blisters or sores in mouth
 - blisters or peeling of the skin
 - redness or swelling of the eyes
 - swelling of the mouth, face, lips, or tongue
 - problems breathing
- **Liver problems.** People with a history of hepatitis B or C virus may have an increased risk of developing new or worsening changes in certain liver tests during treatment with TIVICAY or TIVICAY PD. Liver problems, including liver failure, have also happened in people without a history of liver disease or other risk factors. Your healthcare provider may do blood tests to check your liver. **Call your healthcare provider right away if you develop any of the following signs or symptoms of liver problems:**
 - your skin or the white part of your eyes turns yellow (jaundice)
 - dark or “tea-colored” urine
 - light-colored stools (bowel movements)
 - nausea or vomiting
 - loss of appetite
 - pain, aching, or tenderness on the right side of your stomach area
- **Changes in your immune system (Immune Reconstitution Syndrome)** can happen when you start taking HIV-1 medicines. Your immune system may get stronger and begin to fight infections that have been hidden in your body for a long time. Tell your healthcare provider right away if you start having new symptoms after you start taking TIVICAY or TIVICAY PD.
- **The most common side effects of TIVICAY include:**
 - trouble sleeping
 - tiredness
 - headache

These are not all the possible side effects of TIVICAY or TIVICAY PD. Call your doctor for medical advice about side effects. You may report side effects to FDA at 1-800-FDA-1088.

How should I store TIVICAY or TIVICAY PD?

- Store TIVICAY 10-mg, 25-mg, and 50-mg tablets at room temperature between 68°F to 77°F (20°C to 25°C).

- Store TIVICAY 10-mg tablets in the original bottle. Keep the bottle tightly closed and protected from moisture. The bottle contains a desiccant packet to help keep your medicine dry (protect it from moisture). Do not remove the desiccant packet from the bottle.
- Store TIVICAY PD 5-mg tablets for oral suspension at room temperature below 86°F (30°C) in the original bottle. Keep the bottle tightly closed and protected from moisture. The bottle contains a desiccant packet to help keep your medicine dry (protect it from moisture). Do not remove the desiccant packet from the bottle.

Keep TIVICAY, TIVICAY PD, and all medicines out of the reach of children.

General information about the safe and effective use of TIVICAY or TIVICAY PD.

Medicines are sometimes prescribed for purposes other than those listed in a Patient Information leaflet. Do not use TIVICAY or TIVICAY PD for a condition for which it was not prescribed. Do not give TIVICAY or TIVICAY PD to other people, even if they have the same symptoms you have. It may harm them. You can ask your healthcare provider or pharmacist for information about TIVICAY that is written for health professionals. For more information, go to www.TIVICAY.com or call 1-877-844-8872.

What are the ingredients in TIVICAY and TIVICAY PD?

Active ingredient: dolutegravir.

Inactive ingredients:

TIVICAY tablets: D-mannitol, microcrystalline cellulose, povidone K29/32, sodium starch glycolate, and sodium stearyl fumarate. The tablet film-coating contains the inactive ingredients iron oxide yellow (for the 25-mg and 50-mg tablets only), macrogol/PEG, polyvinyl alcohol-part hydrolyzed, talc, and titanium dioxide.

TIVICAY PD tablets for oral suspension: calcium sulfate dihydrate, crospovidone, mannitol, microcrystalline cellulose, povidone K29/32, silicified microcrystalline cellulose, sodium starch glycolate, strawberry cream flavor, sucralose, and sodium stearyl fumarate. The tablet film-coating contains hypromellose, polyethylene glycol, and titanium dioxide.

Manufactured for:



ViiV Healthcare
Research Triangle Park, NC 27709

by:

GlaxoSmithKline
Research Triangle Park, NC 27709

TIVICAY and TIVICAY PD are trademarks owned by or licensed to the ViiV Healthcare group of companies.

©2020 ViiV Healthcare group of companies or its licensor.

TVC:xxPIL

This Patient Information has been approved by the U.S. Food and Drug Administration.

Revised: 06/2020

INSTRUCTIONS FOR USE
TIVICAY PD (TIV-eh-kay Pe De)
(dolutegravir) tablets for oral suspension
5 mg

Read this Instructions for Use before giving a dose of medicine.

Follow the steps below, using clean drinking water to prepare and give a dose to an infant or a child who cannot swallow the tablets.

Important information

Always give this medicine exactly as your healthcare provider tells you. Talk to your healthcare provider if you are not sure.

Do not chew, cut, or crush the tablets.

If you forget to give a dose of medicine, give it as soon as you remember. Do not give 2 doses at the same time or give more than your healthcare provider has prescribed.

If your child does not or cannot take the full dose, call your healthcare provider.

If you give too much medicine, get emergency medical help right away.

If your child is able and prefers to swallow the tablets, then you may skip the following steps.

Your pack contains:

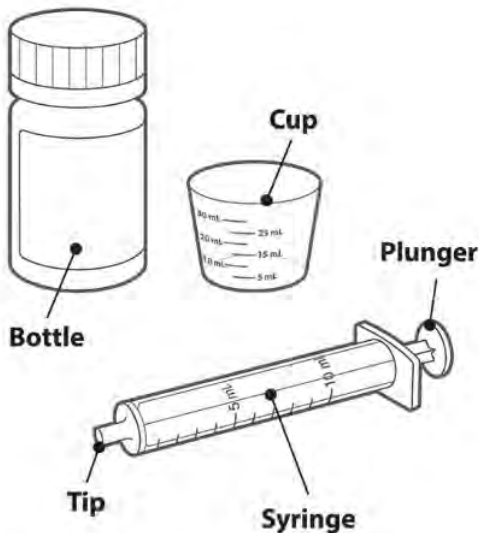

- A bottle containing 60 **TIVICAY PD** tablets for oral suspension.
- Dosing kit:
 - **Cup:** Use this to prepare and give the medicine to **children**.
 - **Syringe:** Use this to give the medicine to **infants**.

You will also need:

- Clean drinking water.

Getting Ready

Step 1. Pour water

- Pour clean drinking water into the cup. The Water Volume Guide in Figure A shows the amount of water needed for the prescribed dose.

Water Volume Guide					
Number of tablets	1	3	4	5	6
Volume of water	5 mL		10 mL		



See Figure A.
Use drinking water only.
Do not use any other drink or food to prepare the dose.

Figure A

Step 2. Prepare the medicine

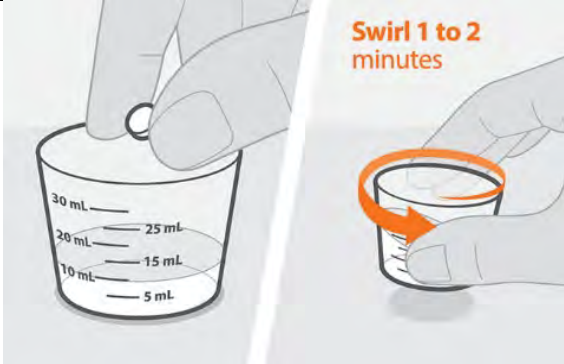

- Add the prescribed number of tablet(s) to the water. **See Figure B.**
- Swirl the cup gently for 1 to 2 minutes to disperse the tablet(s). The medicine will become cloudy. Take care not to spill any of the medicine. **See Figure C.**
- Check that the medicine is ready. If there are any lumps of tablet, swirl the cup until they are gone.

Figure B **Figure C**

If you spill any medicine, clean up the spill.
 Throw away the rest of the prepared medicine and make a new dose.
You must give the dose of medicine within 30 minutes of preparing the dose. If it has been more than 30 minutes, wash away all the dose in the cup using water and prepare a new dose of medicine.

Giving the medicine

Step 3. Give the medicine

Give the medicine to a child



- Make sure that the child is upright. Give all the prepared medicine to the child. **See Figure D.**
- Add another 5 mL of drinking water to the cup, swirl, and give it all to the child.
- **Repeat if any medicine remains in the cup to make sure the child gets the full dose.**

Figure D

Give the medicine to an infant

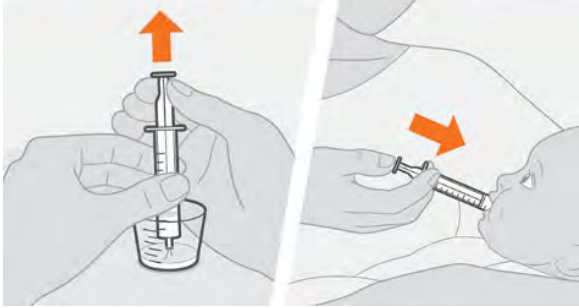

Figure E

Figure F

- Place the tip of the syringe into the prepared medicine and draw up all the medicine into the syringe by pulling up on the plunger. **See Figure E.**
- Place the tip of the syringe against the inside of the infant's cheek. Gently push down the plunger to give the dose slowly. **See Figure F.**
- Add another 5 mL of drinking water to the cup and swirl. Draw up the remaining medicine into the syringe and give it all to the infant.
- **Repeat if any medicine remains in the syringe to make sure the infant gets the full dose.**

Allow time for the medicine to be swallowed.

Cleaning

Step 4. Clean the dosing items



Figure G

Figure H

- Wash the cup with water. **See Figure G.**
- **Pull the plunger out of the syringe and wash the syringe parts separately in water. Allow parts to dry completely before reassembling and storing. See Figure H.**
- All parts will need to be clean before preparing the next dose.

Storage Information

Store TIVICAY PD tablets for oral suspension at room temperature below 86°F (30°C) in the original bottle. Keep the bottle tightly closed and protect from moisture. The bottle contains a desiccant packet to help keep your medicine dry (protect it from moisture). Do not remove the desiccant packet from the bottle.

Keep TIVICAY PD and all medicines out of the reach of children.

Disposal Information

When all the tablets in the bottle have been taken or are no longer needed, throw away the bottle, cup, and syringe. Dispose of them using your local household waste guidelines.

You will get a new cup and syringe in your next pack.

Manufactured for:



ViiV Healthcare

by:

GlaxoSmithKline

Research Triangle Park, NC 27709

Research Triangle Park, NC 27709

Trademark is owned by or licensed to the ViiV Healthcare group of companies.

©2020 ViiV Healthcare group of companies or its licensor.

TVC:xIFU

This Instructions for Use has been approved by the U.S. Food and Drug Administration.

Issued: 06/2020

PRODUCT MONOGRAPH
INCLUDING PATIENT MEDICATION INFORMATION

^{Pr}**TRIUMEQ**

dolutegravir, abacavir, and lamivudine tablets

50 mg dolutegravir (as dolutegravir sodium), 600 mg abacavir (as abacavir sulfate) and 300 mg
lamivudine

Antiretroviral Agent

ViiV Healthcare ULC
245, boulevard Armand-Frappier
Laval, Quebec
H7V 4A7

Date of Revision:
January 31, 2020

Submission Control No: 233245

© 2020 ViiV Healthcare group of companies or its licensor
Trademarks are owned by or licensed to the ViiV Healthcare group of companies

TABLE OF CONTENTS

	PAGE
PART I: HEALTH PROFESSIONAL INFORMATION	3
SUMMARY PRODUCT INFORMATION	3
INDICATIONS AND CLINICAL USE	3
CONTRAINDICATIONS	4
WARNINGS AND PRECAUTIONS	4
ADVERSE REACTIONS	11
DRUG INTERACTIONS	19
DOSAGE AND ADMINISTRATION	24
OVERDOSAGE	26
ACTION AND CLINICAL PHARMACOLOGY	27
STORAGE AND STABILITY	32
SPECIAL HANDLING INSTRUCTIONS	32
DOSAGE FORMS, COMPOSITION AND PACKAGING	32
 PART II: SCIENTIFIC INFORMATION	 33
PHARMACEUTICAL INFORMATION	33
CLINICAL TRIALS	35
DETAILED PHARMACOLOGY	42
TOXICOLOGY	49
REFERENCES	52
 PART III: CONSUMER INFORMATION	 55

TRIUMEQ

dolutegravir, abacavir, and lamivudine tablets

PART I: HEALTH PROFESSIONAL INFORMATION

SUMMARY PRODUCT INFORMATION

Route of Administration	Dosage Form / Strength	Clinically Relevant Nonmedicinal Ingredients ^a
oral	tablet/ 50 mg dolutegravir (as dolutegravir sodium), 600 mg abacavir (as abacavir sulfate) and 300 mg lamivudine	None

a: For a complete list see **DOSAGE FORMS, COMPOSITION and PACKAGING**.

INDICATIONS AND CLINICAL USE

TRIUMEQ (dolutegravir, abacavir, and lamivudine) is indicated for the treatment of Human Immunodeficiency Virus (HIV-1) infection in adults and adolescents aged 12 years and older and weighing at least 40 kg.

Pediatrics (<12 years of age):

The safety and effectiveness of TRIUMEQ in pediatric patients <12 years of age and weighing less than 40 kg has not been established.

Geriatrics (> 65 years of age):

Clinical studies of TRIUMEQ did not include sufficient numbers of patients aged 65 and over to determine whether they respond differently from younger patients. In general, caution should be exercised in the administration and monitoring of TRIUMEQ in elderly patients, reflecting the greater frequency of decreased hepatic, renal or cardiac function and of concomitant disease or other drug therapy.

CONTRAINDICATIONS

TRIUMEQ is contraindicated in patients:

- who are hypersensitive to this drug or to any ingredient in the formulation or component of the container. For a complete listing, see the **DOSAGE FORMS, COMPOSITION AND PACKAGING** section of the product monograph.
- who are positive for the HLA-B*5701 allele and patients with a prior history of a hypersensitivity reaction to abacavir, or products containing abacavir, regardless of HLA-B*5701 status. Fatal hypersensitivity reactions have been associated with rechallenge of abacavir (see **WARNINGS AND PRECAUTIONS**).
- who are prescribed drugs with narrow therapeutic windows, that are substrates of organic cation transporter 2 (OCT2), including but not limited to dofetilide, or fampridine (also known as dalfampridine; see **DRUG INTERACTIONS**).

WARNINGS AND PRECAUTIONS

Serious Warnings and Precautions

- **Fatal Hypersensitivity Reactions**

All patients should be screened for the HLA-B*5701 allele prior to initiating or re-initiating treatment with TRIUMEQ. Patients who carry the HLA-B*5701 allele are at high risk for experiencing a hypersensitivity reaction to abacavir, a component of TRIUMEQ although, hypersensitivity reactions have occurred in patients who do not carry the HLA-B*5701 allele. Serious and sometimes fatal hypersensitivity reactions have been associated with therapy with abacavir sulfate and other abacavir-containing products (see **WARNINGS AND PRECAUTIONS, Hypersensitivity Reactions**).

- **Post Treatment Exacerbations of Hepatitis B**

Severe acute exacerbations of hepatitis B have been reported in patients who are co-infected with hepatitis B virus (HBV) and human immunodeficiency virus (HIV-1) and have discontinued lamivudine, one component of TRIUMEQ. Hepatic function should be monitored closely with both clinical and laboratory follow-up for at least several months in patients who discontinue TRIUMEQ. If appropriate, initiation of anti-hepatitis B therapy may be warranted (see **WARNINGS AND PRECAUTIONS, Hepatic/Biliary/Pancreatic**).

General

Patients prescribed TRIUMEQ or any other antiretroviral therapy may still develop opportunistic infections and other complications of HIV infection. Therefore, patients should remain under close clinical observation by physicians experienced in the treatment of these associated HIV diseases.

While effective viral suppression with antiretroviral therapy has been proven to substantially reduce the risk of sexual transmission, a residual risk cannot be excluded. Precautions to prevent transmission should be taken in accordance with national guidelines.

TRIUMEQ contains fixed doses of an INSTI (dolutegravir) and two nucleoside analogues (abacavir and lamivudine) and should not be administered concomitantly with other products containing abacavir or lamivudine (3TC, COMBIVIR, HEPTOVIR, KIVEXA, TRIZIVIR or ZIAGEN) or emtricitabine-containing products (ATRIPLA, COMPLERA, EMTRIVA, STRIBILD or TRUVADA).

Hypersensitivity Reactions

Both abacavir and dolutegravir are associated with a risk for hypersensitivity reactions (HSR) and share some common features such as fever and/or rash with other symptoms indicating multi-organ involvement (see **Clinical Description of HSRs**). Clinically it is not possible to determine whether a HSR with TRIUMEQ would be caused by abacavir or dolutegravir. Hypersensitivity reactions have been observed more commonly with abacavir, some of which have been life-threatening, and in rare cases fatal, when not managed appropriately. The risk for abacavir HSR to occur is high for patients who test positive for the HLA-B*5701 allele. However, abacavir HSRs have been reported at a low frequency in patients who do not carry this allele.

Clinical Management

All patients should be screened for the HLA-B*5701 allele prior to initiating or re-initiating treatment with TRIUMEQ.

Do not use TRIUMEQ in HLA-B*5701-positive patients or in patients with a negative HLA-B*5701 status who had a suspected abacavir HSR on a previous abacavir-containing regimen.

HLA-B*5701-negative patients may develop a hypersensitivity reaction to abacavir; however, this occurs significantly less frequently than in HLA-B*5701-positive patients.

Regardless of HLA-B*5701 status, permanently discontinue TRIUMEQ if hypersensitivity cannot be ruled out, even when other diagnoses are possible (e.g., acute onset respiratory diseases such as pneumonia, bronchitis, pharyngitis, influenza; gastroenteritis; or reactions to other medications).

Restarting abacavir-containing products following a suspected abacavir HSR can result in a prompt return of symptoms within hours. This recurrence is usually more severe than on initial presentation, and may include life-threatening hypotension and death.

NEVER restart TRIUMEQ or any other abacavir- or dolutegravir-containing product in patients who have stopped therapy with TRIUMEQ due to a hypersensitivity reaction.

When therapy with TRIUMEQ has been discontinued for reasons other than symptoms of a hypersensitivity reaction, and if reinitiation of TRIUMEQ or any other abacavir- or dolutegravir-containing product is under consideration, carefully evaluate the reason for discontinuation of TRIUMEQ to ensure that the patient did not have symptoms of a hypersensitivity reaction.

If hypersensitivity cannot be ruled out, **DO NOT** reintroduce TRIUMEQ or any other abacavir- or dolutegravir-containing product.

If symptoms consistent with abacavir or dolutegravir hypersensitivity are not identified, reintroduction can be undertaken with continued monitoring for symptoms of a hypersensitivity reaction. Make patients aware that a hypersensitivity reaction can occur with reintroduction of TRIUMEQ or any other abacavir- or dolutegravir-containing product. Reintroduction should be attempted only if the potential benefit outweighs the risk and if medical care can be readily accessed by the patient or others in case an adverse reaction occurs.

Clinical Description of HSRs

Hypersensitivity reactions have been reported in <1% of patients treated with dolutegravir in clinical studies, and were characterized by rash, constitutional findings, and sometimes, organ dysfunction, including severe liver reactions.

Abacavir HSR has been well characterised through clinical studies and during post marketing follow-up. Symptoms usually appeared within the first six weeks (median time to onset 11 days) of initiation of treatment with abacavir, **although these reactions may occur at any time during therapy.**

Almost all HSRs to abacavir will include fever and/or rash. Other signs and symptoms that have been observed as part of abacavir HSR may include, respiratory signs and symptoms (including, but not limited to, pharyngitis, dyspnea or cough), and gastrointestinal symptoms (including, but not limited to, nausea, vomiting, diarrhea or abdominal pain). Importantly, such symptoms **may lead to misdiagnosis of HSR as respiratory disease (pneumonia, bronchitis, pharyngitis), or gastroenteritis.** Other frequently observed signs or symptoms of HSR may include, but are not limited to, generalized malaise, fatigue or achiness. The symptoms related to this HSR worsen with continued therapy and **can be life-threatening.** These symptoms usually resolve upon discontinuation of the abacavir-containing product.

A warning card with information for the patient about this hypersensitivity reaction is included as part of the TRIUMEQ outer pack label (see a copy of this card on the last page of this Product Monograph).

Cardiovascular

Several observational and epidemiological studies have reported an association with abacavir use and risk of myocardial infarction. Meta-analyses of randomised controlled trials have observed no excess risk of myocardial infarction with abacavir use. To date, there is no established biological mechanism to explain a potential increase in risk. Overall, the available data from observational studies and from controlled clinical trials show inconsistency and therefore the evidence for a causal relationship between abacavir treatment and the risk of myocardial infarction is inconclusive.

As a precaution, the underlying risk of coronary heart disease should be considered when prescribing antiretroviral therapies, including abacavir, and action taken to minimize all modifiable risk factors (e.g. hypertension, hyperlipidaemia, diabetes mellitus and smoking).

Endocrine and Metabolism

Serum lipids and blood glucose

Serum lipid and blood glucose levels may increase during antiretroviral therapy. Disease control and life style changes may also be contributing factors. Consideration should be given to the measurement of serum lipids and blood glucose. Lipid disorders and blood glucose elevations should be managed as clinically appropriate.

Hematologic

Very rare occurrences of pure red cell aplasia have been reported with lamivudine use. Discontinuation of lamivudine has resulted in normalization of hematologic parameters in patients with suspected lamivudine induced pure red cell aplasia.

Hepatic/Biliary/Pancreatic

Hepatotoxicity

Cases of hepatic toxicity including elevated serum liver biochemistries, hepatitis, and acute liver failure have been reported in patients receiving a dolutegravir-containing regimen who had no pre-existing hepatic disease or other identifiable risk factors. Drug-induced liver injury leading to liver transplant has been reported with TRIUMEQ. Monitoring for hepatotoxicity is recommended.

Liver chemistry changes in patients with Hepatitis B or C co-infection

Patients with underlying hepatitis B or C may be at increased risk for worsening or development of transaminase elevations with use of TRIUMEQ. Liver chemistry elevations consistent with immune reconstitution inflammatory syndrome were observed in some hepatitis B and/or C co-infected patients at the start of dolutegravir therapy. Monitoring of liver chemistries is recommended in patients with hepatitis B and/or C co-infection. Particular diligence should be applied in initiating or maintaining effective hepatitis B therapy (referring to treatment

guidelines) when starting dolutegravir-based therapy in hepatitis B co-infected patients (see **ADVERSE REACTIONS, Abnormal Hematologic and Clinical Chemistry Findings**).

Post-Treatment Exacerbations of Hepatitis B

Clinical study and marketed use of lamivudine have shown that some patients with chronic hepatitis B virus (HBV) disease may experience clinical or laboratory evidence of recurrent hepatitis upon discontinuation of lamivudine, which may have more severe consequences in patients with decompensated liver disease. If TRIUMEQ is discontinued in patients coinfecting with HBV, periodic monitoring of both liver function tests and markers of HBV replication should be considered.

Lactic Acidosis/Severe Hepatomegaly with Steatosis

Lactic acidosis and severe hepatomegaly with steatosis, including fatal cases, have been reported with the use of nucleoside analogues alone or in combination, including abacavir and lamivudine and other antiretrovirals. A majority of these cases have been in women. Clinical features which may be indicative of the development of lactic acidosis include generalized weakness, anorexia and sudden unexplained weight loss, gastrointestinal symptoms and respiratory symptoms (dyspnea and tachypnea). Female sex and obesity may be risk factors. Caution should be exercised when administering TRIUMEQ or other nucleoside analogues, particularly to those with known risk factors for liver disease. However, cases have also been reported in patients with no known risk factors. Treatment with TRIUMEQ should be suspended in any patient who develops clinical or laboratory findings suggestive of lactic acidosis with or without hepatitis, which may include hepatomegaly and steatosis even in the absence of marked transaminase elevations.

Pancreatitis

Pancreatitis has been observed in some patients receiving nucleoside analogues, including abacavir and lamivudine. However, it is not clear whether these cases were due to drug treatment or to the underlying HIV disease. Pancreatitis must be considered whenever a patient develops abdominal pain, nausea, vomiting or elevated biochemical markers. Discontinue use of TRIUMEQ until diagnosis of pancreatitis is excluded (see **ADVERSE EVENTS, Post-Market Adverse Drug Reactions**).

Immune

Immune Reconstitution Inflammatory Syndrome (IRIS)

Immune reconstitution inflammatory syndrome has been reported in HIV-infected patients treated with combination antiretroviral therapy, including TRIUMEQ. During the initial phase of treatment, patients responding to antiretroviral therapy may develop an inflammatory response to indolent or residual opportunistic infections [such as *Mycobacterium avium-complex* (MAC), cytomegalovirus (CMV), *Pneumocystis jirovecii pneumonia* (PCP), and *tuberculosis* (TB)], which may necessitate further evaluation and treatment.

Autoimmune disorders (such as Graves' disease, polymyositis, autoimmune hepatitis and Guillain-Barre syndrome) have also been reported to occur in the setting of immune reconstitution, however, the time to onset is more variable, and can occur many months after initiation of treatment and sometimes can be an atypical presentation.

Special Populations

Pregnant Women

TRIUMEQ has not been studied in pregnant women. TRIUMEQ should not be used in pregnant women unless the potential benefits outweigh the potential risk to the fetus. Women of childbearing potential (WOCBP) should undergo pregnancy testing before initiation of TRIUMEQ and should be advised to use effective contraception throughout treatment. Initiation of TRIUMEQ is not recommended in adolescents and adults actively trying to become pregnant unless there is no suitable alternative. If there are plans to become pregnant or if pregnancy is confirmed within the first trimester while on TRIUMEQ, the risks and benefits of continuing TRIUMEQ versus switching to another antiretroviral regimen should be assessed and switching to an alternative regimen should be considered. TRIUMEQ may be considered during the second and third trimesters of pregnancy if the expected benefit justifies the potential risk to the pregnant woman and the fetus.

In a birth outcome surveillance study in Botswana there have been 5 cases of neural tube defects reported in 1,683 deliveries (0.3%) to mothers taking dolutegravir-containing regimens from the time of conception, compared with 15 cases in 14,792 deliveries (0.1%) to mothers taking non-dolutegravir-containing regimens from the time of conception (Prevalence Difference 0.20%; 95% CI 0.01-0.59). In the same study, one out of 3,840 deliveries (0.03%) to mothers who started dolutegravir during pregnancy had a neural tube defect, compared with three out of 5,952 deliveries (0.05%) to mothers who started non dolutegravir-containing regimens during pregnancy. A causal relationship of these events to the use of dolutegravir has not been established. The incidence of neural tube defects in the general population ranges from 0.5-1 case per 1,000 live births. As neural tube defects occur within the first 4 weeks of foetal development (at which time the neural tubes are sealed) this potential risk would concern women exposed to dolutegravir at the time of conception and in early pregnancy.

Data analysed to date from other sources including the Antiretroviral Pregnancy Registry, clinical trials, and post-marketing data are insufficient to address the risk of neural tube defects

with dolutegravir. More than 1,000 outcomes from second and third trimester exposure in pregnant women indicate no evidence of increased risk of adverse birth outcomes.

In reproductive toxicity studies in animals, dolutegravir was shown to cross the placenta and no evidence of impaired fertility or harm to the fetus, including neural tube defects, was identified. Lamivudine and abacavir were associated with findings in animal reproductive toxicity studies (see **TOXICOLOGY, Reproductive Toxicology**).

There have also been very rare reports of developmental delay, seizures and other neurological disease. However, a causal relationship between these events and NRTI exposure *in utero* or peri-partum has not been established. These findings do not affect current recommendations to use antiretroviral therapy in pregnant women to prevent vertical transmission of HIV.

There have been reports of mild, transient elevations in serum lactate levels, which may be due to mitochondrial dysfunction, in neonates and infants exposed *in utero* or peri-partum to nucleoside reverse transcriptase inhibitors (NRTIs). The clinical relevance of transient elevations in serum lactate is unknown.

Antiretroviral Pregnancy Registry

To monitor maternal-fetal outcomes of pregnant women exposed to ART (antiretroviral therapy), including TRIUMEQ, an Antiretroviral Pregnancy Registry has been established. Healthcare providers are encouraged to register patients:

<http://www.apregistry.com>

Telephone: (800) 258-4263

Fax: (800) 800-1052

Nursing Women

HIV-1 infected mothers should not breastfeed their infants to avoid risking postnatal transmission of HIV.

It is expected that dolutegravir will be excreted into human milk based on animal data, although this has not been confirmed in humans. Lamivudine is excreted in human milk at similar concentrations to those found in serum. Abacavir is also excreted in human breast milk at similar concentrations as plasma levels. Because of both the potential for HIV transmission and the potential for serious adverse reactions in nursing infants, mothers should be instructed not to breastfeed if they are receiving TRIUMEQ.

Pediatrics (<12 years of age)

TRIUMEQ is not recommended in pediatric patients weighing less than 40kg as the necessary dose adjustment cannot be made. The safety and effectiveness of TRIUMEQ in pediatric patients <12 years of age and weighing less than 40 kg has not been established.

Geriatrics (≥ 65 years of age)

Clinical studies of TRIUMEQ did not include sufficient numbers of patients aged 65 and older to determine whether they respond differently from younger patients. In general, caution should be

exercised in the administration and monitoring of TRIUMEQ in elderly patients, reflecting the greater frequency of decreased hepatic, renal or cardiac function and of concomitant disease or other drug therapy.

Hepatic impairment

TRIUMEQ is not recommended in patients with moderate to severe hepatic impairment (Child-Pugh grade B or C) (see **DOSAGE AND ADMINISTRATION, Dosage Adjustment** and **ACTION AND CLINICAL PHARMACOLOGY, Special Populations and Conditions**). If a dose reduction of abacavir, a component of TRIUMEQ, is required for patients with mild hepatic impairment (Child-Pugh grade A), then the separate preparations of dolutegravir, abacavir and lamivudine should be used.

Renal Impairment

TRIUMEQ is not recommended for use in patients with a creatinine clearance < 50 mL/min as TRIUMEQ is a fixed-dose combination and the dosage of the individual components cannot be adjusted. If patients require a dose reduction due to renal impairment, separate preparations of dolutegravir, abacavir and lamivudine should be administered (see **DOSAGE AND ADMINISTRATION, Dosage Adjustment** and **ACTION AND CLINICAL PHARMACOLOGY, Special Populations and Conditions**).

ADVERSE REACTIONS

Adverse Drug Reaction Overview

The following adverse reactions are discussed in other sections of the labelling:

- Serious and sometimes fatal hypersensitivity reaction (see **WARNINGS AND PRECAUTIONS, Hypersensitivity Reactions**)
- Serum lipids and blood glucose (see **WARNINGS AND PRECAUTIONS, Endocrine and Metabolism**)
- Lactic acidosis and severe hepatomegaly (see **WARNINGS AND PRECAUTIONS, Hepatic/Biliary/Pancreatic, Lactic Acidosis/Severe Hepatomegaly with Steatosis**)
- Effects on serum liver biochemistries in patients with hepatitis B or C co-infection (see **WARNINGS AND PRECAUTIONS, Hepatic/Biliary/Pancreatic, Liver chemistry changes in patients with Hepatitis B or C co-infection**)
- Post-treatment exacerbations of hepatitis (see **WARNINGS AND PRECAUTIONS, Hepatic/Biliary/Pancreatic, Post-Treatment Exacerbations of Hepatitis B**)
- Myocardial infarction (see **WARNINGS AND PRECAUTIONS, Cardiovascular**)

Clinical Trial Adverse Drug Reactions

Because clinical trials are conducted under very specific conditions the adverse reaction rates observed in the clinical trials may not reflect the rates observed in practice and

should not be compared to the rates in the clinical trials of another drug. Adverse drug reaction information from clinical trials is useful for identifying drug-related adverse events and for approximating rates.

In addition to the events reported here, please consult the TIVICAY and KIVEXA Product Monographs.

Treatment-Emergent Adverse Drug Reaction

Treatment-Naïve Patients

The safety assessment of TRIUMEQ is primarily based on the analyses of 48- and 96-week data from a randomized, international, multicentre, double-blind, active-controlled study SINGLE (ING114467); and supported by 96 week data in treatment-naïve subjects from SPRING-2 (ING113086) and 48 week data in FLAMINGO (ING114915).

In SINGLE, 833 treatment-naïve patients received at least one dose of either dolutegravir (TIVICAY) 50 mg with fixed-dose abacavir and lamivudine (KIVEXA) once daily (N = 414) or fixed-dose efavirenz/emtricitabine/tenofovir (ATRIPLA) once daily (N = 419). Through 96 weeks, the rates of adverse events leading to discontinuation were 3% in subjects receiving TIVICAY + KIVEXA and 12% in subjects receiving ATRIPLA once daily.

In SPRING-2, 411 patients received TIVICAY 50 mg once daily versus 411 who received raltegravir 400 mg twice daily, both in combination with investigator-selected nucleoside reverse transcriptase inhibitor (NRTI) background regimen (either KIVEXA or TRUVADA). Of these patients, 169 in the group receiving TIVICAY and 164 in the group receiving raltegravir were receiving KIVEXA as the background regimen. Through 96 weeks, the rate of adverse events leading to discontinuation in these patients was 3% in patients receiving TIVICAY and 2% in patients receiving raltegravir.

In FLAMINGO, 242 patients received TIVICAY 50 mg once daily versus 242 patients who received darunavir 800 mg/ritonavir 100 mg once daily, both in combination with investigator-selected NRTI background regimen (either KIVEXA or TRUVADA). Of these patients, 33% in each group received KIVEXA as the background regimen. Through 48 weeks, the rate of adverse events leading to discontinuation in these patients was 4% in each group.

Treatment-emergent adverse reactions in SINGLE of moderate to severe intensity with a $\geq 2\%$ frequency in either treatment are provided in Table 1.

Table 1 Treatment-Emergent Adverse Drug Reactions of at Least Moderate Intensity (Grades 2 to 4) and $\geq 2\%$ Frequency in Treatment-Naive Subjects in SINGLE

Body System/ Preferred Term	48 Week Analysis		96 Week Analysis	
	TIVICAY + KIVEXA QD (N = 414)	ATRIPLA QD (N = 419)	TIVICAY + KIVEXA QD (N = 414)	ATRIPLA QD (N = 419)
Psychiatric				
Insomnia	13 (3%)	9 (2%)	14 (3%)	10 (2%)
Depression	4 (<1%)	5 (1%)	5 (1%)	9 (2%)
Abnormal dreams	2 (<1%)	8 (2%)	3 (<1%)	8 (2%)
Nervous System				
Dizziness	2 (<1%)	19 (5%)	2 (<1%)	21 (5%)
Headache	7 (2%)	9 (2%)	8 (2%)	9 (2%)
Gastrointestinal				
Nausea	3 (<1%)	12 (3%)	3 (<1%)	12 (3%)
Diarrhea	4 (<1%)	7 (2%)	3 (<1%)	7 (2%)
General Disorders				
Fatigue	6 (1%)	5 (1%)	7 (2%)	7 (2%)
Skin and Subcutaneous Tissue				
Rash	1 (<1%)	14 (3%)	1 (<1%)	14 (3%)
Ear and Labyrinth				
Vertigo	0	7 (2%)	0 (0%)	7 (2%)

The adverse drug reactions observed in the subset of patients who received TIVICAY + KIVEXA in SPRING-2 and FLAMINGO were generally consistent with observations in SINGLE.

The adverse drug reactions and laboratory abnormalities observed at 144 weeks in SINGLE were generally consistent with those seen at 48 and 96 weeks.

Pediatric Patients

Abacavir and Lamivudine

The safety of once-daily compared with twice-daily dosing of abacavir and lamivudine, administered as either single products or as KIVEXA, was assessed in the ARROW trial (n = 336). Primary safety assessment in the ARROW (COL105677) trial was based on Grade 3 and Grade 4 adverse events. One event of Grade 4 hepatitis in the once-daily cohort was considered as uncertain causality by the investigator and all other Grade 3 or 4 adverse events

were considered not related by the investigator. No additional safety issues were identified in pediatric subjects compared with historical data in adults.

Dolutegravir

IMPAACT P1093 is a 48-week multicenter, open-label, non-comparative trial of approximately 160 HIV-1-infected pediatric subjects aged 4 weeks to less than 18 years, of which, 23 treatment-experienced, INSTI-naïve subjects aged 12 to less than 18 years were enrolled.

The ADR profile was similar to that for adults. Grade 2 ADRs reported by more than one subject were decreased neutrophil count (n = 2). No Grade 3 or 4 ADRs were reported. No ADRs led to discontinuation. The Grade 3 laboratory abnormalities reported in 1 subject each were elevated total bilirubin, elevated lipase, and decreased white blood cell count. There was one Grade 4 decreased neutrophil count. The changes in mean serum creatinine were similar to those observed in adults.

Less Common Clinical Trial Adverse Drug Reactions (<2%)

The following treatment-emergent adverse reactions occurred in <2% of treatment-naïve or treatment-experienced adult subjects in any one trial. These events have been included because of their seriousness and/or assessment of potential causal relationship.

Gastrointestinal Disorders: Abdominal pain, abdominal distention, abdominal discomfort, dyspepsia, flatulence, gastro-oesophageal reflux disease, upper abdominal pain, vomiting

General Disorders: Fever, lethargy

Hepatobiliary Disorders: Hepatitis

Immune System Disorders: Hypersensitivity, immune reconstitution inflammatory syndrome

Metabolism and Nutrition Disorders: Anorexia, hypertriglyceridemia

Musculoskeletal and Connective Tissue Disorders: Arthralgia, myalgia, myositis

Nervous Systems Disorders: Somnolence

Psychiatric: Nightmare, sleep disorder, depression, suicidal ideation or suicide attempt (particularly in patients with a pre-existing history of depression or psychiatric illness)

Renal and Urinary Disorders: Renal impairment

Skin and Subcutaneous Tissue Disorders: Pruritus

Abnormal Hematologic and Clinical Chemistry Findings

Treatment-Naive Patients

Selected laboratory abnormalities (Grades 2 to 4) with a worsening grade from baseline and representing the worst-grade toxicity in $\geq 2\%$ of subjects in SINGLE are presented in Table 2.

Table 2 Selected Laboratory Abnormalities (Grades 2 to 4) in Treatment-Naive Subjects in SINGLE

Laboratory Parameter Preferred Term (Unit)	48 Week		96 Week	
	TIVICAY 50 mg + KIVEXA QD (N = 414)	ATRIPLA QD (N = 419)	TIVICAY 50 mg + KIVEXA QD (N = 414)	ATRIPLA QD (N = 419)
ALT (IU/L)				
Grade 2 (>2.5-5.0 x ULN)	9 (2%)	20 (5%)	10 (2%)	22 (5%)
Grade 3 to 4 (>5.0 x ULN)	1 (<1%)	2 (<1%)	2 (<1%)	2 (<1%)
AST (IU/L)				
Grade 2 (>2.5-5.0 x ULN)	7 (2%)	13 (3%)	12 (3%)	13 (3%)
Grade 3 to 4 (>5.0 x ULN)	0 (0%)	10 (2%)	1 (<1%)	11 (3%)
Creatine kinase (IU/L)				
Grade 2 (6.0-9.9 x ULN)	15 (4%)	7 (2%)	16 (4%)	7 (2%)
Grade 3 to 4 (≥ 10.0 x ULN)	11 (3%)	19 (5%)	21 (5%)	28 (7%)
Hyperglycemia (mmol/L)				
Grade 2 (6.95-13.88 mmol/L)	28 (7%)	19 (5%)	30 (7%)	21 (5%)
Grade 3 to 4 (>13.88 mmol/L)	6 (1%)	1 (<1%)	8 (2%)	2 (<1%)
Lipase (U/L)				
Grade 2 (>1.5-3.0 x ULN)	33 (8%)	30 (7%)	39 (9%)	40 (10%)
Grade 3 to 4 (>3.0 ULN)	11 (3%)	8 (2%)	16 (4%)	13 (3%)
Phosphorus, inorganic (mmol/L)				
Grade 2 (0.65-0.80 mmol/L)	37 (9%)	52 (12%)	49 (12%)	70 (17%)
Grade 3 to 4 <0.65mmol/L)	5 (1%)	12 (3%)	5 (1%)	12 (3%)
Total neutrophils ($10^3/\mu\text{L}$)				
Grade 2 ($0.75-0.99 \times 10^9$)	10 (2%)	15 (4%)	12 (3%)	21 (5%)
Grade 3 to 4 ($<0.75 \times 10^9$)	7 (2%)	12 (3%)	10 (2%)	14 (3%)

ULN = Upper limit of normal.

The mean change from baseline observed for selected lipid values from SINGLE is presented in Table 3.

Table 3 Mean Change From Baseline in Fasted Lipid Values in Treatment-Naive Patients in SINGLE

Laboratory Parameter Preferred Term (unit)	48 Weeks*		96 Weeks	
	TIVICAY 50 mg + KIVEXA QD (N = 414)	ATRIPLA QD (N = 419)	TIVICAY 50 mg + KIVEXA QD (N = 414)	ATRIPLA QD (N = 419)
Cholesterol (mmol/L)	0.44	0.62	0.62	0.72
HDL cholesterol (mmol/L)	0.14	0.21	0.14	0.19
LDL cholesterol (mmol/L)	0.22	0.34	0.38	0.47
Total cholesterol/HDL (ratio)	-0.09	-0.10	0.12	0.02
Triglycerides (mmol/L)	0.20	0.21	0.20	0.20

*SINGLE Study: p-value versus ATRIPLA at Week 48; pre-defined p-value adjusted for baseline value and stratification factors: p= 0.005 for cholesterol and p= 0.032 for LDL cholesterol

Laboratory abnormalities observed in the subset of patients who received TIVICAY + KIVEXA in SPRING-2 and FLAMINGO were generally consistent with observations in SINGLE.

Dolutegravir: Hepatitis C Virus Co-infection

In SINGLE, the pivotal Phase III study, patients with hepatitis C co-infection were permitted to enrol provided that baseline liver chemistry tests did not exceed 5 times the upper limit of normal (ULN); patients with hepatitis B co-infection were excluded from the SINGLE study. Overall, the safety profile in patients co-infected with hepatitis C was similar to that observed in patients without hepatitis C co-infection, although the rates of AST and ALT abnormalities were higher in the subgroup with hepatitis C co-infection for both treatment groups. Grades 2 to 4 ALT abnormalities in hepatitis C co-infected patients compared with HIV mono-infected patients receiving TRIUMEQ were observed in 15% and 2% (vs. 24% and 4% of patients treated with ATRIPLA), respectively (see **WARNING AND PRECAUTIONS, Hepatic/Biliary/Pancreatic**).

Changes in Clinical Laboratory Values

Dolutegravir has been shown to increase serum creatinine due to inhibition of tubular secretion of creatinine without affecting renal glomerular function. Increases in serum creatinine occurred within the first four weeks of treatment and remained stable through 24 to 96 weeks. In SINGLE, a mean change from baseline of 12.6 µmol/L (range: -28 µmol/L to 52 µmol/L) was observed after 96 weeks of treatment. Creatinine increases were similar in treatment-experienced patients (see **ACTION AND CLINICAL PHARMACOLOGY, Pharmacodynamics**).

Increases in total bilirubin (without clinical jaundice) were observed on TIVICAY and ISENTRESS (but not efavirenz) arms in the dolutegravir development programme. In the SINGLE study, at 96 weeks, a mean change of -0.52 µmol/L (range -19 µmol/L to 14 µmol/L) was observed and are not considered clinically relevant as they likely reflect competition between dolutegravir and unconjugated bilirubin for a common clearance pathway (UGT1A1) (see **ACTION AND CLINICAL PHARMACOLOGY, Pharmacokinetics**).

In the SINGLE study, grade 3 to 4 creatine phosphokinase (CPK) abnormalities were reported in 5% of patients at week 96. Cases of myalgia or myositis with concurrent CPK elevations have been reported in the dolutegravir programme; relationship with the use of dolutegravir could not be excluded.

Abacavir Sulfate and Lamivudine: Laboratory abnormalities observed in clinical trials were neutropenia, anemia, thrombocytopenia, hyperlactatemia, and transient rise in liver enzymes (AST, ALT and GGT).

Post-Market Adverse Drug Reactions

In addition to the adverse events included from clinical trial data, the following adverse events listed below have been identified during post-approval use of dolutegravir, abacavir, lamivudine or the fixed dose combination (dolutegravir/abacavir/lamivudine FDC) tablet.

These events have been chosen for inclusion due to either their seriousness, frequency of reporting, potential causal connection to dolutegravir, abacavir and lamivudine, or a combination of these factors. Because they are reported voluntarily from a population of unknown size, estimates of frequency cannot be made.

Dolutegravir

Musculoskeletal and connective tissue disorders: arthralgia, myalgia

Psychiatric disorders: anxiety

Investigations: weight increased

Abacavir

Endocrine/Metabolic: lactic acidosis (see **WARNINGS AND PRECAUTIONS, Hepatic/Biliary/Pancreatic**), hepatic steatosis

Digestive: pancreatitis

Immune System: Immune Reconstitution Inflammatory Syndrome (see **WARNINGS AND PRECAUTIONS, Immune**)

Skin: rash, erythema multiforme, suspected Stevens-Johnson syndrome (SJS) and toxic epidermal necrolysis (TEN) (primarily in combination with medications known to be associated with SJS and TEN, respectively). Because of the overlap of the clinical signs and symptoms between hypersensitivity to abacavir, SJS and TEN and the possibility of multiple drug sensitivities in some patients, abacavir should be discontinued and not restarted in such cases.

Lamivudine

Body as a whole: anaphylaxis, weakness

Hematological: pure red cell aplasia

Hemic and Lymphatic: anemia, lymphadenopathy, splenomegaly
 Endocrine/Metabolic: lactic acidosis (see **WARNINGS AND PRECAUTIONS, Hepatic/Biliary/Pancreatic**), hyperlactatemia, hepatic steatosis, hyperglycemia
 Nervous: paresthesia, peripheral neuropathy
 Digestive: rises in serum amylase, pancreatitis, stomatitis
 Immune System: Immune Reconstitution Inflammatory Syndrome (see **WARNINGS AND PRECAUTIONS, Immune**)
 Skin: alopecia, pruritus, urticaria
 Musculoskeletal: muscle disorders including rarely rhabdomyolysis, arthralgia

Dolutegravir/Abacavir/Lamivudine FDC Tablet

Hepatobiliary Disorders: acute hepatic failure

Detailed Description of Abacavir Hypersensitivity Adverse Reactions

Abacavir hypersensitivity

The signs and symptoms of abacavir hypersensitivity reaction are listed below. These have been identified either from clinical studies or post marketing surveillance. Those reported in at least 10% of patients with a hypersensitivity reaction are in **bold** text.

As described in Warnings and Precautions, almost all patients developing hypersensitivity reactions will have fever and/or rash (usually maculopapular or urticarial) as part of the syndrome, however, reactions have occurred without rash or fever. Other key symptoms include gastrointestinal, respiratory or constitutional symptoms such as lethargy and malaise.

Skin:	Rash (usually maculopapular or urticarial)
Gastrointestinal tract:	Nausea, vomiting, diarrhoea, abdominal pain , mouth ulceration
Respiratory tract:	Dyspnoea, cough , sore throat, adult respiratory distress syndrome, respiratory failure
Miscellaneous:	Fever, fatigue, malaise , oedema, lymphadenopathy, hypotension, conjunctivitis, anaphylaxis
Neurological/Psychiatry:	Headache , paraesthesia
Haematological:	Lymphopenia
Liver/pancreas:	Elevated liver function tests , hepatic failure
Musculoskeletal:	Myalgia , rarely myolysis, arthralgia, elevated creatine phosphokinase
Urology:	Elevated creatinine, renal failure

Restarting abacavir following an abacavir HSR results in a prompt return of symptoms within hours. This recurrence of the HSR is usually more severe than on initial presentation, and may include life-threatening hypotension and death. Reactions have also occurred infrequently after restarting abacavir in patients who had only one of the key symptoms of hypersensitivity (see above) prior to stopping abacavir; and on very rare occasions have also been seen in patients who have restarted therapy with no preceding symptoms of a HSR (i.e., patients previously considered to be abacavir tolerant).

For details of clinical management in the event of a suspected abacavir HSR (see **WARNINGS AND PRECAUTIONS, Hypersensitivity Reactions - Clinical Management**).

DRUG INTERACTIONS

Overview

No drug interaction studies have been conducted with TRIUMEQ Tablets. Drug interaction trials were conducted with dolutegravir, abacavir, and/or lamivudine, the components of TRIUMEQ™. Due to different routes of metabolism and elimination, and the minimal effect of these agents on drug metabolizing enzymes or transporters, no clinically significant drug interactions are expected between dolutegravir, abacavir, and lamivudine.

Effect of Dolutegravir, Abacavir and Lamivudine on the Pharmacokinetics of Other Agents

Dolutegravir

In vitro, dolutegravir inhibited the renal organic cation transporter 2, OCT2 ($IC_{50} = 1.93 \mu M$), multidrug and toxin extrusion transporter (MATE) 1 ($IC_{50}=6.34 \mu M$) and MATE2-K ($IC_{50}=24.8 \mu M$). *In vivo*, dolutegravir has a low potential to affect the transport of MATE2-K substrates. *In vivo*, dolutegravir inhibits tubular secretion of creatinine by inhibiting OCT2. Dolutegravir may increase plasma concentrations of drugs in which excretion is dependent upon OCT2 (for example dofetilide, fampridine (also known as dalfampridine) (see **CONTRAINDICATIONS**) and metformin) or MATE1 (see Table 4).

In vitro, dolutegravir inhibited the basolateral renal transporters: organic anion transporter (OAT) 1 ($IC_{50} = 2.12 \mu M$) and OAT3 ($IC_{50} = 1.97 \mu M$). Based upon the dolutegravir unbound plasma concentration, *in silico* modelling, and no notable effect on the pharmacokinetics *in vivo* of the OAT substrates tenofovir and para aminohippurate, dolutegravir has low propensity to cause drug interactions via inhibition of OAT transporters.

In vitro, dolutegravir did not inhibit ($IC_{50}>50 \mu M$) the enzymes: cytochrome P₄₅₀ (CYP)1A2, CYP2A6, CYP2B6, CYP2C8, CYP2C9, CYP2C19, CYP2D6, CYP3A, uridine diphosphate glucuronosyl transferase (UGT)1A1 or UGT2B7, or the transporters: P-glycoprotein (Pgp), breast cancer resistance protein (BCRP), bile salt export pump (BSEP), organic anion transporter polypeptide 1B1 (OATP1B1), OATP1B3, organic cation transporter1 (OCT)1, multidrug resistance-associated protein 2 (MRP2), or MRP4. *In vitro*, dolutegravir did not induce CYP1A2, CYP2B6, or CYP3A4. Based on these data, and the drug interactions studies, dolutegravir is not expected to affect the pharmacokinetics of drugs that are substrates of these enzymes or transporters.

In drug interaction studies, dolutegravir did not have a clinically relevant effect on the pharmacokinetics of the following: tenofovir, methadone, rilpivirine, and oral contraceptives containing norgestimate and ethinyl estradiol. Using cross-study comparisons to historical pharmacokinetic data for each interacting drug, dolutegravir did not appear to affect the pharmacokinetics of the following drugs: atazanavir, darunavir, efavirenz, etravirine,

fosamprenavir, lopinavir, ritonavir, boceprevir and telaprevir (see **DETAILED PHARMACOLOGY, Pharmacokinetics**).

Abacavir and Lamivudine

Abacavir and lamivudine do not inhibit or induce CYP enzymes (such as CYP 3A4, CYP 2C9 or CYP 2D6) and demonstrate no or weak inhibition of the OATP1B1, OATP1B3, BCRP and Pgp or and toxin extrusion protein 2-K (MATE2-K). In addition, lamivudine demonstrates no or weak inhibition of the drug transporters MATE1 or OCT3 and abacavir demonstrates minimal inhibition of OCT1 and OCT2. Abacavir and lamivudine are therefore not expected to affect the plasma concentrations of drugs that are substrates of these enzymes or transporters.

Although abacavir is an inhibitor of MATE1 and lamivudine is an inhibitor of OCT1 and OCT2 *in vitro*, they have low potential to affect the plasma concentrations of substrates of these transporters at therapeutic drug exposures (up to 600 mg for abacavir or 300 mg for lamivudine).

Effect of Other Agents on the Pharmacokinetics of Dolutegravir, Abacavir and Lamivudine

Dolutegravir

Dolutegravir is metabolised by UGT1A1 with some contribution from CYP3A. Dolutegravir is also a substrate of UGT1A3, UGT1A9, CYP3A4, Pgp, and BCRP *in vitro*; therefore drugs that induce those enzymes and transporters, may decrease dolutegravir plasma concentration and reduce the therapeutic effect of dolutegravir.

Co-administration of dolutegravir and other drugs that inhibit UGT1A1, UGT1A3, UGT1A9, CYP3A4, and/or Pgp may increase dolutegravir plasma concentration (see Table 4).

In vitro, dolutegravir is not a substrate of human organic anion transporting polypeptide (OATP)1B1, OATP1B3, or OCT1, therefore drugs that solely modulate these transporter are not expected to affect dolutegravir plasma concentration.

Etravirine significantly reduced plasma concentrations of dolutegravir but the effect of etravirine was mitigated by co-administration of lopinavir/ritonavir or darunavir/ritonavir, and is expected to be mitigated by atazanavir/ritonavir.

Tenofovir, lopinavir/ritonavir, darunavir/ritonavir, rilpivirine, boceprevir, telaprevir, prednisone, rifabutin, and omeprazole had no clinically significant effect on dolutegravir pharmacokinetics.

Abacavir and Lamivudine

The likelihood of metabolic interactions with abacavir and lamivudine is low. Abacavir and lamivudine are not significantly metabolised by CYP enzymes. The primary pathways of abacavir metabolism in human are by alcohol dehydrogenase and by glucuronidation to produce the 5'-carboxylic acid and 5'-glucuronide which account for about 66% of the administered dose. These metabolites are excreted in the urine. The likelihood of metabolic interactions with lamivudine is low due to limited metabolism and plasma protein binding, and almost complete

renal clearance. Lamivudine is predominantly eliminated by active organic cationic secretion. The possibility of interactions with other medicinal products administered concurrently should be considered, particularly when the main route of elimination is renal. *In vitro*, abacavir is not a substrate of OATP1B1, OATP1B3, OCT1, OCT2, OAT1, MATE1, MATE2-K, MRP2 or MRP4 therefore drugs that modulate these transporters are not expected to affect abacavir plasma concentrations.

Although abacavir and lamivudine are substrates of BCRP and Pgp *in vitro*, clinical studies demonstrate no clinically significant changes in abacavir pharmacokinetics when co-administered with lopinavir/ritonavir (Pgp and BCRP inhibitors) and inhibitors of these efflux transporters are unlikely to affect the disposition of lamivudine due to its high bioavailability. Lamivudine is an *in vitro* substrate of MATE1, MATE2-K and OCT2. Trimethoprim (an inhibitor of these drug transporters) has been shown to increase lamivudine plasma concentrations however; the resulting increase was of such magnitude that a dose adjustment is not recommended as it is not expected to have clinical significance. Lamivudine is a substrate of the hepatic uptake transporter OCT1. As hepatic elimination plays a minor role in the clearance of lamivudine, drug interactions due to inhibition of OCT1 are unlikely to be of clinical significance.

Established and Other Potentially Significant Drug Interactions

Selected drug interactions are presented in Table 4. Recommendations are based on either drug interaction studies or predicted interactions due to the expected magnitude of interaction and potential for serious adverse events or loss of efficacy.

Table 4 Established or Potential Dolutegravir, Abacavir and Lamivudine Drug-Drug Interactions

Concomitant Drug Class: Drug Name	Effect on Concentration	Clinical Comment
DOLUTEGRAVIR		
HIV-1 Antiviral Agents		
Non-nucleoside Reverse Transcriptase Inhibitor: Etravirine ^a (ETR)	Dolutegravir↓ ETR ↔	No dose adjustment of TRIUMEQ is needed if etravirine is taken with atazanavir/ritonavir, darunavir/ritonavir, or lopinavir/ritonavir. Adjust dolutegravir dose to 50 mg twice daily in patients taking etravirine without a boosted protease inhibitor. An additional dolutegravir 50-mg dose should be taken, separated by 12 hours from TRIUMEQ. TRIUMEQ should only be used with etravirine when co-administered with atazanavir/ritonavir, darunavir/ritonavir or lopinavir/ritonavir in INI-resistant patients.

Concomitant Drug Class: Drug Name	Effect on Concentration	Clinical Comment
Non-nucleoside Reverse Transcriptase Inhibitor: Efavirenz ^a (EFV)	Dolutegravir↓ EFV ↔	Adjust dolutegravir dose to 50 mg twice daily. An additional 50-mg dose of dolutegravir should be taken, separated by 12 hours from TRIUMEQ.
Non-nucleoside Reverse Transcriptase Inhibitor: Nevirapine	Dolutegravir↓	Co-administration with nevirapine should be avoided because there are insufficient data to make a dosing recommendation.
Protease Inhibitor: Atazanavir (ATV)	Dolutegravir↑ ATV ↔	Atazanavir increased dolutegravir plasma concentration. No dose adjustment is necessary.
Protease Inhibitor: Atazanavir/ritonavir (ATV + RTV)	Dolutegravir↑ ATV ↔ RTV ↔	Atazanavir/ritonavir increased dolutegravir plasma concentration. No dose adjustment is necessary.
Protease Inhibitor: Tipranavir/ritonavir ^a (TPV+RTV)	Dolutegravir↓ TPV ↔ RTV ↔	Adjust dolutegravir dose to 50 mg twice daily. An additional 50-mg dose of dolutegravir should be taken, separated by 12 hours from TRIUMEQ.
Protease Inhibitor: Fosamprenavir/ritonavir ^a (FPV+RTV)	Dolutegravir↓ FPV ↔ RTV ↔	Adjust dolutegravir dose to 50 mg twice daily. An additional 50-mg dose of dolutegravir should be taken, separated by 12 hours from TRIUMEQ.
Protease Inhibitor: Lopinavir/ritonavir (LPV+RTV)	Dolutegravir ↔ LPV↔ RTV↔	Lopinavir/ritonavir did not change dolutegravir plasma concentration to a clinically relevant extent. No dose adjustment is necessary.
Other Agents		
Antiarrhythmic: Dofetilide	Dofetilide ↑	Co-administration of dolutegravir has the potential to increase dofetilide plasma concentration via inhibition of OCT2 transporter; co-administration has not been studied. TRIUMEQ and dofetilide co-administration is contraindicated due to potential life-threatening toxicity caused by high dofetilide concentration.
Potassium channel blocker: Fampridine (also known as dalfampridine)	Fampridine/dalfampridine↑	Co-administration is contraindicated with TRIUMEQ due to potential for seizures associated with fampridine/dalfampridine.
Anticonvulsants: Oxcarbazepine Carbamazepine Phenytoin Phenobarbital	Dolutegravir↓	Adjust dolutegravir dose to 50 mg twice daily. The additional 50-mg dose of dolutegravir should be taken, separated by 12 hours from TRIUMEQ. Co-administration with these metabolic inducers should be avoided in INI-resistant patients.
Medications containing polyvalent cations (e.g. Mg, Al) Cation-containing antacids ^a or laxative, sucralfate, buffered medications	Dolutegravir↓	TRIUMEQ is recommended to be administered 2 hours before or 6 hours after taking medications containing polyvalent cations.

Concomitant Drug Class: Drug Name	Effect on Concentration	Clinical Comment
Calcium and iron supplements ^a	Dolutegravir ↓	When taken with food, TRIUMEQ and calcium and/or iron supplements or multivitamins containing calcium and/or iron can be taken at the same time. Under fasting conditions, TRIUMEQ should be taken 2 hours before or 6 hours after taking supplements containing calcium and/or iron.
Antidiabetics: Metformin	Metformin ↑	Consider metformin dose adjustments when starting or stopping concomitant treatment to maintain glycemic control.
Rifampin ^a	Dolutegravir ↓	Adjust dolutegravir dose to 50 mg twice daily. An additional 50-mg dose of dolutegravir should be taken, separated by 12 hours from TRIUMEQ.
ABACAVIR		
Ethanol	Abacavir AUC ↑ Ethanol AUC ↔	Given the safety profile of abacavir, these findings are not considered clinically significant.
Methadone	Abacavir AUC ↔ C _{max} ↓ Methadone CL/F ↑	The changes in abacavir pharmacokinetics are not considered clinically relevant. The changes in methadone pharmacokinetics are not considered clinically relevant for the majority of patients, however occasionally methadone dose re-titration may be required.
LAMIVUDINE		
Trimethoprim/sulfamethoxazole (Co-trimoxazole)	Lamivudine: AUC ↑ Trimethoprim: AUC ↔ Sulfamethoxazole: AUC ↔	Unless the patient has renal impairment, no dosage adjustment of lamivudine is necessary (see DOSAGE AND ADMINISTRATION, Dosage Adjustment). Lamivudine has no effect on the pharmacokinetics of trimethoprim or sulfamethoxazole. The effect of coadministration of lamivudine with higher doses of co-trimoxazole used for the treatment of <i>Pneumocystis jiroveci</i> pneumonia (often referred to as PCP) and toxoplasmosis has not been studied.

Concomitant Drug Class: Drug Name	Effect on Concentration	Clinical Comment
Emtricitabine		Lamivudine may inhibit the intracellular phosphorylation of emtricitabine when the two medicinal products are used concurrently. Additionally, the mechanism of viral resistance for both lamivudine and emtricitabine is mediated via mutation of the same viral reverse transcriptase gene (M184V) and therefore the therapeutic efficacy of these drugs in combination therapy may be limited. TRIUMEQ is not recommended for use in combination with emtricitabine or emtricitabine-containing fixed-dose combinations.
Sorbitol solution (3.2 , 10.2 g, 13.4 g)	Single dose lamivudine oral solution 300 mg Lamivudine: AUC ↓ 14%; 32%; 36% C _{max} ↓ 28%; 52%, 55%.	When possible, avoid chronic coadministration of sorbitol-containing medicines with lamivudine. Consider more frequent monitoring of HIV-1 viral load when chronic coadministration cannot be avoided.

^a See **DETAILED PHARMACOLOGY, Pharmacokinetics** for magnitude of interaction (Table 8 and Table 9).

Drug-Food Interactions

TRIUMEQ may be administered with or without food (see **ACTION AND CLINICAL PHARMACOLOGY, Pharmacokinetics**).

Drug-Herb Interactions

No interaction study has been conducted, however, St. John's Wort is a potent CYP3A inducer and may potentially decrease dolutegravir plasma concentration. In adults and adolescent patients, an additional dose of TIVICAY 50 mg separated by 12 hours from TRIUMEQ may be considered when taken together with St. John's Wort. St. John's Wort should be avoided in INI-resistant patients.

Drug-Laboratory Interactions

No Drug-Laboratory interactions have been identified.

DOSAGE AND ADMINISTRATION

Dosing Considerations

TRIUMEQ can be taken with or without food.

Perform pregnancy testing before initiation of TRIUMEQ in individuals of childbearing potential.

Recommended Dose

Adults and adolescents (≥12years and weighing at least 40 kg)

The recommended dose of TRIUMEQ is one tablet once daily. One tablet contains 50 mg of dolutegravir (as dolutegravir sodium), 600 mg abacavir (as abacavir sodium) and 300 mg of lamivudine.

Special Populations

Pediatrics (<12years)

The safety and effectiveness of TRIUMEQ in pediatric patients <12 years of age and weighing less than 40 kg have not been established. TRIUMEQ is not recommended for treatment of children weighing less than 40 kg as the necessary dose adjustment cannot be made.

Geriatrics (≥ 65 years of age)

There are limited data available on the use of dolutegravir, abacavir and lamivudine (TRIUMEQ) in patients aged 65 years and older. In general, caution should be exercised in the administration of TRIUMEQ in elderly patients reflecting the greater frequency of decreased hepatic, renal or cardiac function and of concomitant disease or other drug therapy.

Dosage Adjustment

The separate components of dolutegravir (TIVICAY), abacavir (ZIAGEN) and lamivudine (3TC) should be considered in cases where dose adjustment or discontinuation of an individual component is indicated.

TRIUMEQ is not recommended for patients requiring dosage adjustments, such as:

- patients with renal impairment (creatinine clearance < 50 mL/min) (see **ACTION AND CLINICAL PHARMACOLOGY, Special Populations and Conditions, Renal Impairment**)
- patients with hepatic impairment (see **ACTION AND CLINICAL PHARMACOLOGY, Special Populations and Conditions, Hepatic Impairment**)

Dosage Recommendation with Certain Concomitant Medications

TRIUMEQ alone is insufficient for patients with integrase inhibitor resistance requiring dolutegravir 50 mg twice daily (see **TIVICAY Product Monograph**).

The dolutegravir dose (50 mg) in TRIUMEQ is insufficient when co-administered with medications listed in Table 5 that may decrease dolutegravir concentrations: the following dolutegravir dosage regimen is recommended.

Table 5 Dosing Recommendations for TRIUMEQ with Co-administered Medications

Co-administered Drug	Dosing Recommendation
Efavirenz, etravirine*, fosamprenavir/ritonavir, tipranavir/ritonavir, oxcarbamazepine, carbamazepine, phenytoin, phenobarbital, St. John’s wort or rifampin	Adjust dolutegravir dose to 50 mg twice daily. The additional 50-mg dose of dolutegravir should be taken, separated by 12 hours from TRIUMEQ

*TRIUMEQ should only be used with etravirine when co-administered with atazanavir/ritonavir, darunavir/ritonavir or lopinavir/ritonavir in INI-resistant patients

Missed Dose

If a dose is missed, patients should take the missed dose as soon as possible unless it is within 4 hours of their next scheduled dose. If a dose is skipped, the patient should not double the next dose.

OVERDOSAGE

For management of a suspected drug overdose, contact your regional Poison Control Centre.

If overdosage occurs, the patient should be monitored, and standard supportive treatment applied as required.

Dolutegravir: As dolutegravir is highly bound to plasma proteins, it is unlikely that it will be significantly removed by dialysis.

There is currently limited experience with overdosage in dolutegravir. Limited experience of single higher doses (up to 250 mg in healthy subjects) revealed no specific symptoms or signs, apart from those listed as adverse reactions.

Abacavir: It is not known whether abacavir can be removed by peritoneal dialysis or hemodialysis.

Lamivudine: Since lamivudine is dialysable, continuous haemodialysis could be used in the treatment of overdose, although this has not been studied.

No specific symptoms or signs have been identified following acute overdose with abacavir or lamivudine, apart from those listed as adverse reactions.

ACTION AND CLINICAL PHARMACOLOGY

Mechanism of Action

Dolutegravir inhibits HIV integrase by binding to the integrase active site and blocking the strand transfer step of retroviral Deoxyribonucleic acid (DNA) integration which is essential for the HIV replication cycle. *In vitro*, dolutegravir dissociates slowly from the active site of the wild type integrase-DNA complex (t_{1/2} 71 hours). Strand transfer biochemical assays using purified HIV-1 integrase and pre-processed substrate DNA resulted in IC₅₀ values of 2.7 nM and 12.6 nM.

Abacavir and lamivudine are nucleoside reverse transcriptase inhibitors (NRTIs), and are potent, selective inhibitors of HIV-1 and HIV-2 replication *in vitro*. Abacavir is a carbocyclic synthetic nucleoside analogue of deoxyguanosine-5'-triphosphate and lamivudine is also a synthetic nucleoside analogue, an (-) enantiomer of a dideoxy analogue of cytidine. Both abacavir and lamivudine are metabolized sequentially by intracellular kinases to their respective triphosphate (TP), which are the active moieties (carbovir triphosphate (CBV-TP) for abacavir; and lamivudine triphosphate (L-TP) for lamivudine). The extended intracellular half-lives of CBV-TP and L-TP support once daily dosing (see **ACTION AND CLINICAL PHARMACOLOGY, Pharmacokinetics, Metabolism and Excretion**). L-TP and CBV-TP are substrates for and competitive inhibitors of HIV reverse transcriptase (RT). Inhibition of RT is via viral DNA chain termination after nucleoside analogue incorporation. CBV-TP and L-TP show significantly less affinity for host cell DNA polymerases and are weak inhibitors of mammalian α , β and γ -DNA polymerases.

Pharmacodynamics

In a randomized, dose-ranging trial, HIV-1–infected subjects treated with dolutegravir monotherapy (ING111521) demonstrated rapid and dose-dependent antiviral activity, with mean declines from baseline to day 11 in HIV-1 RNA of 1.5, 2.0, and 2.5 log₁₀ for dolutegravir 2 mg, 10 mg, and 50 mg once daily, respectively. This antiviral response was maintained for 3 to 4 days after the last dose in the 50 mg group.

Effects on Electrocardiogram: In a randomized, placebo-controlled, cross-over trial, 42 healthy subjects received single dose oral administrations of placebo, dolutegravir 250 mg suspension (exposures approximately 3-fold of the 50 mg once-daily dose at steady state), and moxifloxacin (400 mg, active control) in random sequence. After baseline and placebo adjustment, the maximum mean QTc change based on Fridericia correction method (QTcF) was 1.99 msec (1-sided 95% upper CI: 4.53 msec). TIVICAY did not prolong the QTc interval for 24 hours post dose. The effect of the combination regimen TRIUMEQ on the QT interval is not known.

Effects on Renal Function: The effect of dolutegravir on serum creatinine clearance (CrCl), glomerular filtration rate (GFR) using iohexol as the probe and effective renal plasma flow (ERPF) using para-aminohippurate (PAH) as the probe was evaluated in an open-label, randomized, 3 arm, parallel, placebo-controlled study in 37 healthy subjects, who were administered dolutegravir 50 mg once daily (n=12), 50 mg twice daily (n=13) or placebo once

daily (n=12) for 14 days. A decrease in CrCl, as determined by 24-hour urine collection, was observed with both doses of dolutegravir (9% and 13%, for dolutegravir 50mg once daily and twice daily, respectively). Dolutegravir had no significant effect on GFR or ERPF at either dose level.

Pharmacokinetics

Pharmacokinetics in Adults: One TRIUMEQ Tablet was bioequivalent to one TIVICAY Tablet (50 mg) plus one EPZICOM Tablet under fasted conditions in healthy subjects (n = 62).

Absorption: Dolutegravir, abacavir and lamivudine are rapidly absorbed following oral administration. The absolute bioavailability of dolutegravir has not been established. The absolute bioavailability of oral abacavir and lamivudine in adults is 83 and 80 to 85% respectively. The mean time to maximal serum concentrations (t_{max}) is about 2 to 3 hours (post dose for tablet formulation) for dolutegravir, 1.5 hours for abacavir and 1.0 hours for lamivudine.

Following multiple oral doses of dolutegravir 50 mg once daily, the geometric mean steady state pharmacokinetic parameter estimates are 53.6 micrograms.h/mL for AUC₂₄, 3.67 microgram/mL for C_{max}, and 1.11 microgram/mL for C₂₄. Following a single oral dose of 600 mg of abacavir, the mean C_{max} is 4.26 µg/mL and the mean AUC_∞ is 11.95 µg.h/mL. Following multiple dose oral administration of lamivudine 300 mg once daily for seven days the mean steady state C_{max} is 2.04 µg/mL and the mean AUC₂₄ is 8.87 µg.h/mL.

Effects of Food on Oral Absorption: TRIUMEQ may be administered with or without food. Administration of TRIUMEQ with a high-fat, high-calorie meal resulted in 48% higher AUC and 37% higher C_{max} for dolutegravir, no change in AUC and C_{max} of lamivudine, no change in the AUC and a 23% decrease in C_{max} of abacavir, and prolonged T_{max} for all three drugs compared in the fasted state (n = 12). This is not considered clinically significant.

Distribution: The apparent volume of distribution (Vd/F) following 50 mg once daily oral administration of suspension formulation was estimated at 17.4 L based on population pharmacokinetic analysis. Intravenous studies with abacavir and lamivudine showed that the mean apparent volume of distribution is 0.8 and 1.3 L/kg respectively.

Dolutegravir is highly bound ($\geq 98.9\%$) to human plasma proteins based on *in vivo* data and binding is independent of plasma dolutegravir concentration. Plasma protein binding studies *in vitro* indicate that abacavir binds only low to moderately ($\sim 49\%$) to human plasma proteins at therapeutic concentrations. Lamivudine exhibits linear pharmacokinetics over the therapeutic dose range and displays low plasma protein binding ($< 36\%$).

Cerebrospinal Fluid (CSF): In 12 treatment-naïve subjects on dolutegravir 50 mg daily plus abacavir/lamivudine, the median dolutegravir concentration in CSF was 13.2 ng/mL (ranging from 3.7 ng/mL to 18.3 ng/mL) 2 to 6 hours post-dose after 16 weeks of treatment. At Week 16, 100% of subjects (n = 11) had CSF HIV-1 RNA < 50 c/mL (median change from baseline was $-3.42 \log_{10}$ copies/mL). Studies with abacavir demonstrate a CSF to plasma AUC ratio of between 30 to 44%. The observed values of the peak concentrations are 9 fold greater than the IC₅₀ of abacavir of 0.08 µg/mL or 0.26 µM when abacavir is given at 600 mg twice daily. The mean

ratio of CSF/serum lamivudine concentrations 2-4 hours after oral administration was approximately 12%. The true extent of CNS penetration of lamivudine and its relationship with any clinical efficacy is unknown.

Metabolism and Excretion: Dolutegravir is primarily metabolized via UGT1A1 with some contribution from CYP3A. Renal elimination of unchanged drug was low (< 1% of the dose). After a single oral dose of [¹⁴C] dolutegravir, 53% of the total oral dose was excreted unchanged in the faeces. Thirty-one percent of the total oral dose was excreted in the urine, represented by an ether glucuronide of dolutegravir (18.9% of total dose), N-dealkylation metabolite (3.6% of total dose), and a metabolite formed by oxidation at the benzylic carbon (3.0% of total dose).

Abacavir is primarily metabolized by the liver with less than 2% of the administered dose being renally excreted as unchanged compound. The primary pathways of metabolism in humans are by alcohol dehydrogenase and by glucuronidation to produce the 5'-carboxylic acid and 5'-glucuronide which account for about 66% of the administered dose. These metabolites are excreted in the urine.

Metabolism of lamivudine is a minor route of elimination. Lamivudine is predominately cleared unchanged by renal excretion. The likelihood of metabolic interactions with lamivudine is low due to the small extent of hepatic metabolism (< 10%).

Dolutegravir has a terminal half-life of approximately 14 hours and an apparent clearance (CL/F) of 0.9-1.05 L/hr based on population pharmacokinetic analyses.

The mean half life of abacavir is about 1.5 hours. The geometric mean terminal half-life of intracellular carbovir-TP at steady-state is 20.6 hours. Following multiple oral doses of abacavir 300 mg twice a day, there is no significant accumulation of abacavir. Elimination of abacavir is via hepatic metabolism with subsequent excretion of metabolites primarily in the urine. The metabolites and unchanged abacavir account for about 83% of the administered abacavir dose in the urine. The remainder is eliminated in the feces.

The observed lamivudine half life of elimination is 18 to 19 hours. For patients receiving lamivudine 300 mg once daily, the terminal intracellular half-life of lamivudine-TP was prolonged to 16 to 19 hours. The mean systemic clearance of lamivudine is approximately 0.32 L/h/kg, predominantly by renal clearance (> 70%) via the organic cationic transport system.

Special Populations and Conditions

Pediatrics: The pharmacokinetics of TRIUMEQ have not been established in pediatric subjects. Dosing recommendations are based on safety, efficacy, and pharmacokinetics of abacavir, lamivudine, and TIVICAY as single entities or in various combinations.

Abacavir and Lamivudine: Limited pharmacokinetic data are available in adolescents receiving a daily dose of 600 mg of abacavir and 300 mg of lamivudine. Pharmacokinetic parameters are comparable to those reported in adults.

Abacavir is rapidly and well absorbed from oral solution and tablet formulations when administered to children. Plasma abacavir exposure has been shown to be the same for both formulations when administered at the same dose. Children receiving abacavir oral solution

according to the recommended dosage regimen achieve plasma abacavir exposure similar to adults. Children receiving abacavir oral tablets according to the recommended dosage regimen achieve higher plasma abacavir exposure than children receiving oral solution because higher mg/kg doses are administered with the tablet formulation. Pediatric pharmacokinetic studies have demonstrated that once daily dosing provides equivalent AUC₀₋₂₄ to twice daily dosing of the same total daily dose for both oral solution and tablet formulations.

The absolute bioavailability of lamivudine (approximately 58 to 66%) was lower and more variable in pediatric patients under 12 years of age. In children, administration of tablets delivered higher plasma lamivudine AUC_∞ and C_{max} than oral solution. Children receiving lamivudine oral solution according to the recommended dosage regimen achieve plasma lamivudine exposure within the range of values observed in adults. Children receiving lamivudine oral tablets according to the recommended dosage regimen achieve higher plasma lamivudine exposure than children receiving oral solution because higher mg/kg doses are administered with the tablet formulation and the tablet formulation has higher bioavailability. Pediatric pharmacokinetic studies with both oral solution and tablet formulations have demonstrated that once daily dosing provides equivalent AUC₀₋₂₄ to twice daily dosing of the same total daily dose (See KIVEXA Product Monograph).

Dolutegravir: In a paediatric study including 23 antiretroviral treatment-experienced HIV-1 infected adolescents aged 12 to 18 years of age, the pharmacokinetics of dolutegravir was evaluated in 10 adolescents and showed that dolutegravir 50 mg once daily dosage resulted in dolutegravir exposure in paediatric subjects comparable to that observed in adults who received dolutegravir 50 mg once daily (Table 6).

Table 6 Paediatric pharmacokinetic parameters (n=10)

Age/weight	Dolutegravir Dose	Dolutegravir Pharmacokinetic Parameter Estimates Geometric Mean (CV%)		
		AUC ₍₀₋₂₄₎ µg.hr/mL	C _{max} µg/mL	C ₂₄ µg/mL
12 to <18 years ≥40 kg ^a	50 mg once daily ^a	46 (43)	3.49 (38)	0.90 (59)

^a One subject weighing 37 kg received 35 mg once daily.

Geriatrics: Population pharmacokinetic analyses using pooled pharmacokinetic data from adult trials indicated age had no clinically relevant effect on the pharmacokinetics of dolutegravir. Pharmacokinetic data for dolutegravir, abacavir and lamivudine in subjects of >65 years old are limited.

Gender: Population PK analyses using pooled pharmacokinetic data from adult studies revealed no clinically relevant effect of gender on the exposure of dolutegravir.

Race: Population PK analyses using pooled pharmacokinetic data from adult studies revealed no clinically relevant effect of race on the exposure of dolutegravir.

Hepatic Impairment: Pharmacokinetic data has been obtained for dolutegravir, abacavir and lamivudine alone. Based on data obtained for abacavir, TRIUMEQ is not recommended in patients with moderate to severe hepatic impairment.

Abacavir is metabolised primarily by the liver. The pharmacokinetics of abacavir have been studied in patients with mild hepatic impairment (Child-Pugh score A) who had confirmed cirrhosis.

The results showed that there was a mean increase of 1.89 fold in the abacavir AUC, and 1.58 fold in the half life of abacavir. The AUCs of the metabolites were not modified by the liver disease. However, the rates of formation and elimination of these were decreased. If a dosage reduction of abacavir, a component of TRIUMEQ, is required in patients with mild hepatic impairment, then the separate preparations of dolutegravir (TIVICAY), abacavir (ZIAGEN), and lamivudine (3TC) should be used. The pharmacokinetics of abacavir have not been studied in patients with moderate or severe hepatic impairment. Plasma concentrations of abacavir are expected to be variable and substantially increased in these patients. TRIUMEQ is therefore not recommended in patients with moderate to severe hepatic impairment.

Data obtained for lamivudine in patients with moderate to severe hepatic impairment and for dolutegravir in patients with moderate hepatic impairment show that the pharmacokinetics are not significantly affected by hepatic dysfunction.

Dolutegravir is primarily metabolized and eliminated by the liver. In a study comparing 8 subjects with moderate hepatic impairment (Child-Pugh score B) to 8 matched healthy adult controls, exposure of dolutegravir from a single 50 mg dose was similar between the two groups. The effect of severe hepatic impairment (Child-Pugh score C) on the pharmacokinetics of dolutegravir has not been studied.

Renal Impairment: Pharmacokinetic data have been obtained for dolutegravir, abacavir and lamivudine alone. TRIUMEQ should not be used in patients with creatinine clearance of less than 50 mL/min because; whilst no dosage adjustment of dolutegravir or abacavir is necessary in patients with renal impairment, dose reduction is required for the lamivudine component. As dosage reduction is not possible with TRIUMEQ, the separate preparations of dolutegravir (TIVICAY), abacavir (ZIAGEN), and lamivudine (3TC) should be used.

Studies with lamivudine show that plasma concentrations (AUC) are increased in patients with renal dysfunction due to decreased clearance.

Abacavir is primarily metabolised by the liver, with approximately 2% of abacavir excreted unchanged in the urine. The pharmacokinetics of abacavir in patients with end-stage renal disease is similar to patients with normal renal function.

Renal clearance of unchanged drug is a minor pathway of elimination for dolutegravir. In a study comparing 8 subjects with severe renal impairment (CrCL<30 mL/min) to 8 matched healthy controls, the mean AUC, C_{max} and C₂₄ of dolutegravir in renally impaired subjects were decreased by 40%, 23% and 43%, respectively. No dosage adjustment is necessary for INI-naive

patients with renal impairment. There is limited information on dolutegravir in patients on dialysis.

Polymorphisms in Drug Metabolizing Enzymes: In a meta-analysis using pharmacogenomics samples collected in clinical studies in healthy subjects, subjects with UGT1A1 (n=7) genotypes conferring poor dolutegravir metabolism had a 32% lower clearance of dolutegravir and 46% higher AUC compared with subjects with genotypes associated with normal metabolism via UGT1A1 (n=41).

Hepatitis B/Hepatitis C Co-infection: Population analyses using pooled pharmacokinetic data from adult studies indicated no clinically relevant effect of Hepatitis C co-infection on the pharmacokinetics of dolutegravir. There were limited pharmacokinetic data on Hepatitis B co-infection

STORAGE AND STABILITY

Store up to 30°C.

Store in the original package in order to protect from moisture. Keep the bottle tightly closed. Do not remove the desiccant.

SPECIAL HANDLING INSTRUCTIONS

There are no special requirements for use or handling of this product.

DOSAGE FORMS, COMPOSITION AND PACKAGING

Dosage Forms

TRIUMEQ tablets are purple, biconvex, oval, film-coated tablets, debossed with “572 Tri” on one side.

Composition

Each film-coated tablet contains dolutegravir sodium equivalent to 50 mg of dolutegravir (as 52.6 mg dolutegravir sodium), abacavir sulfate equivalent to 600 mg of abacavir (as 702 mg abacavir sulfate) and 300 mg of lamivudine, and the following inactive ingredients: D-mannitol, magnesium stearate, microcrystalline cellulose, povidone K29/32, and sodium starch glycolate. The tablet film-coating (OPADRY® II Purple 85F90057) contains the inactive ingredients iron oxide black, iron oxide red, macrogol/PEG, polyvinyl alcohol–part hydrolyzed, talc, and titanium dioxide.

Packaging

TRIUMEQ is available in 100 cc HDPE bottles containing 30 tablets and a silica gel desiccant.

PART II: SCIENTIFIC INFORMATION

PHARMACEUTICAL INFORMATION

Dolutegravir

Drug Substance

Proper name: dolutegravir sodium

Chemical name:

sodium (4*R*,12*aS*)-9- {[(2,4-difluorophenyl)methyl]carbamoyl} -4-methyl-6,8-dioxo-3,4,6,8,12,12*a*-hexahydro-2*H*-pyrido[1',2':4,5]pyrazino[2,1-*b*][1,3]oxazin-7-olate

Molecular formula: C₂₀H₁₈F₂N₃NaO₅

Molecular mass (dolutegravir sodium): 441.36 g/mol

Molecular mass (dolutegravir free acid): 419.38 g/mol

Structural formula:

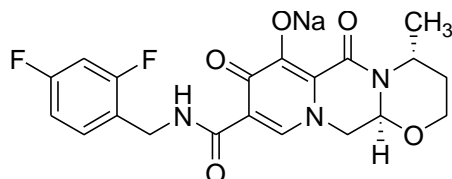

Physicochemical properties:

Description: Dolutegravir sodium is a white to light yellow powder and is slightly soluble in water.

Solubility: The solubility in water at 25°C is 3.176 mg/mL. The pKa is 8.2.

Abacavir

Drug Substance

Proper name: abacavir sulfate

Chemical name:

(1*S*,*cis*)-4-[2-amino-6-(cyclopropylamino)-9*H*-purin-9-yl]-2-cyclopentene-1-methanol sulfate (salt) (2:1)

Molecular formula: $(C_{14}H_{18}N_6O)_2 \cdot H_2SO_4$

Molecular mass: 670.76

Structural formula:

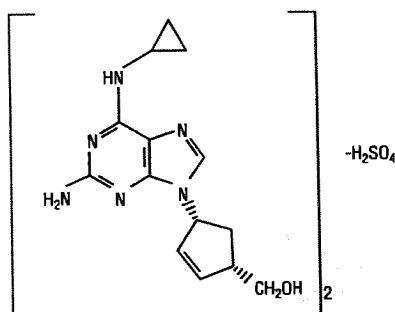

Physicochemical properties:

Description: abacavir sulfate is a white to off-white powder with a melting point around 219°C followed by decomposition.

Solubility: The aqueous solubility and pH of abacavir sulfate was determined at 25°C as follows:

Solvent	Solubility (mg/mL)	pH
Distilled water	77	3.1
0.1 M HCl	110	1.6
0.1 M NaOH	22	12.2

pKa: The pK_a for abacavir have been determined by UV spectroscopy at 25°C as follows: pK₁ = 0.4, pK₂ = 5.06.

Lamivudine

Drug Substance

Proper name: lamivudine

Chemical name:

2(1H)-Pyrimidinone, 4-amino-1-[2- (hydroxymethyl)-1,3-oxathiolan-5-yl]-(2R-cis)-

Molecular formula: $C_8H_{11}N_3O_3S$

Molecular mass: 229.3

Structural formula:

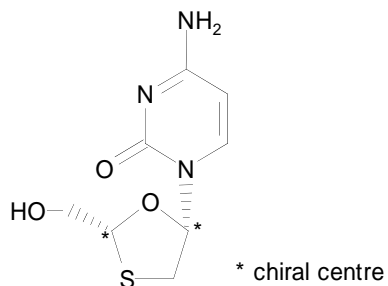

Physicochemical properties:

Description: Lamivudine is a white to off-white crystalline solid with a melting point of 176°C.

Solubility:

Solvent	Temperature (°C)	Solubility (mg/mL)
Water	15	61.3
Water	25	98.1
Methanol	25	33.4
Ethanol	25	11.4
Acetone	25	0.94

pKa and pH: The pH value of a 1% w/v solution in water is approximately 6.9.
The pK_a determined by UV is 4.30.

CLINICAL TRIALS

The efficacy of TRIUMEQ is supported by data from three randomized, controlled studies in antiretroviral treatment-naïve subjects, SINGLE (ING114467: 48 and 96 weeks), SPRING-2 (ING113086: 48 and 96 weeks), and FLAMINGO (ING114915: 48 weeks).

The following clinical studies have been conducted with the individual products, TIVICAY and KIVEXA.

Treatment-Naïve Subjects: In SINGLE, 833 patients were randomized and received at least 1 dose of either TIVICAY 50 mg once daily with KIVEXA (abacavir and lamivudine) or ATRIPLA (efavirenz/emtricitabine/tenofovir disoproxil fumarate). At baseline, the median age of subjects was 35 years, 16% female, 32% non-white, 7% had hepatitis C co-infection (hepatitis B virus co-infection was excluded), 4% were CDC Class C (AIDS), 32% had HIV-1 RNA >100,000 copies/mL, and 53% had CD4+ cell count <350 cells/mm³; these characteristics were similar between treatment groups.

Virologic outcomes (including outcomes by key baseline covariates) are described below.

Table 7 Virologic Outcomes of Randomized Treatment in SINGLE at 48 Weeks and 96 Weeks (Snapshot Algorithm)

	48 Weeks		96 Weeks	
	TIVICAY + KIVEXA QD N=414 n (%)	ATRIPLA QD N=419 n (%)	TIVICAY + KIVEXA QD N=414 n (%)	ATRIPLA QD N=419 n (%)
HIV-1 RNA <50 copies/mL	364 (88)	338 (81)	332 (80)	303 (72)
Treatment Difference*	7.4% (95% CI: 2.5%, 12.3%), p = 0.003		8.0% (95% CI: 2.3%, 13.8%), p = 0.006	
Virologic non-response†	21 (5)	26 (6)	31 (7)	33 (8)
No virologic data	29 (7)	55 (13)	51 (12)	83 (20)
Reasons:				
Discontinued study/study drug due to adverse event or death‡	9 (2)	40 (10)	13 (3)	48 (11)
Discontinued study/study drug for other reasons§	20 (5)	14 (3)	36 (9)	35 (8)
Missing data during window but on study	0	1 (<1)	2 (<1)	0
HIV-1 RNA <50 copies/mL by baseline covariates				
Baseline Plasma Viral Load (copies/mL)	n / N (%)	n / N (%)	n / N (%)	n / N (%)
≤100,000	253 / 280 (90)	238 / 288 (83)	237 / 280 (85)	209 / 288 (73)
>100,000	111 / 134 (83)	100 / 131 (76)	95 / 134 (71)	94 / 131 (72)
Baseline CD4+ (cells/ mm³)				
<200	45 / 57 (79)	48 / 62 (77)	39 / 57 (68)	45 / 62 (73)
200 to <350	143 / 163 (88)	126 / 159 (79)	135 / 163 (83)	113 / 159 (71)
≥350	176 / 194 (91)	164 / 198 (83)	158 / 194 (81)	145 / 198 (73)
<p>* Adjusted for baseline stratification factors. † Includes patients who discontinued prior to Week 48/96 for lack or loss of efficacy and patients who are ≥50 copies in the Week 48/96 window. ‡ Includes patients who discontinued due to an adverse event or death at any time point from Day 1 through the Week 48/96 analysis window if this resulted in no virologic data on treatment during the analysis window. § Includes reasons such as withdrew consent, loss to follow-up, moved, protocol deviation. Notes: ABC/3TC = abacavir 600 mg, lamivudine 300 mg in the form of Kivexa fixed dose combination (FDC) EFV/TDF/FTC = efavirenz 600 mg, tenofovir 300 mg, emtricitabine 200 mg in the form of Atripla FDC. N = Number of patients in each treatment group</p>				
<p>Snapshot algorithm: Subjects whose last HIV-1 RNA result was <50 c/mL in the analysis window (i.e. 48 ± 6 weeks, 96 ± 6 weeks) were counted as responders; subjects who were not suppressed or did not have data at the analysis time point were counted as non-responders.</p>				

In the SINGLE primary 48 week analysis, there was a statistically significant difference in the proportion of subjects with HIV-1 RNA <50 copies/mL between the group receiving TIVICAY + KIVEXA (88%) compared to the ATRIPLA group (81%) (p=0.003). The virologic suppression treatment differences were comparable across baseline characteristics (gender, race and age, HIV-1 RNA and CD4+ cell count).

At 48 and 96 weeks, the adjusted mean change in CD4+ T cell count from baseline were 267 cells/mm³ and 325 cells/mm³ in the group receiving TIVICAY + KIVEXA and 208 cells/mm³ and 281 cells/mm³ for the ATRIPLA arm, respectively. The respective adjusted differences and 95% CIs were 58.9 and 44 (33.4, 84.4 and 14.34, 73.55), and were statistically significant p<0.001 and p=0.004 (repeated measure model adjusting for the baseline stratification factors: baseline HIV-1 RNA and baseline CD4+ T cell count, among other factors).

The median time to viral suppression was 28 days in the group receiving TIVICAY + KIVEXA and 84 days in the ATRIPLA arm in SINGLE (p<0.0001). At 28 days (week 4), 63% of patients in the TIVICAY arm reached virologic suppression, compared to 14% in the ATRIPLA arm.

Virologic suppression was maintained through 144 weeks (open-label phase week 96 to 144 week). The proportion of subjects achieving HIV-1 RNA<50 copies/mL was 71% for the dolutegravir + KIVEXA group and 63% for the ATRIPLA group (treatment difference 8.3% (95% CI: 2.0%, 14.6%, p=0.010)). The adjusted mean change in CD4+ T cell count from baseline was 378 cells/mm³ in the group receiving TIVICAY + KIVEXA, which continued to be statistically significantly different from the ATRIPLA arm (332 cells/mm³) (treatment difference 47 cells/mm³ (95% CI: 15.61, 78.20) p=0.003).

In SPRING-2, 822 adults were randomized and received at least one dose of either dolutegravir 50 mg once daily or raltegravir 400 mg twice daily, both administered with fixed-dose dual NRTI therapy (either KIVEXA or TRUVADA). Of these patients, 169/411 in the group receiving dolutegravir and 164/411 in the group receiving raltegravir were receiving KIVEXA as the background regimen. At baseline, median patient age was 36 years, 14% were female, 15% non-white, 11% had hepatitis B and/or C co-infection, and 2% were CDC Class C, 28% had HIV-1 RNA >100,000 copies/mL and 47% had CD4+ cell count <350 cells/mm³. These characteristics were similar between treatment groups.

Overall virologic suppression (HIV-1 RNA <50 copies/mL) observed with either background regimen in the dolutegravir group (88%) was non-inferior to the raltegravir group (85%) at 48 weeks (non-inferiority margin -10%). The adjusted difference in proportion and 95% CI were 2.5 (-2.2, 7.1). At 96 weeks, virologic suppression in the dolutegravir group (81%) remained non-inferior to the raltegravir group (76%). The adjusted difference in proportion and 95% CI were 4.5 (-1.1, 10.0). Response rates at 48 weeks were 86% and 87% for dolutegravir + KIVEXA and raltegravir + KIVEXA, respectively. Response rates at 96 weeks were 74% and 76 % for dolutegravir + KIVEXA and for raltegravir + KIVEXA, respectively.

The overall median change in CD4+ cell count from baseline to Week 96 in the dolutegravir group was +276.0 cells/mm³, compared to +264.0 cells/mm³ in the raltegravir arm.

Through 144 weeks in SINGLE and 96 weeks in SPRING-2, no treatment emergent resistance to dolutegravir, abacavir, or lamivudine in background therapy were isolated on the dolutegravir-containing arms.

In FLAMINGO, an open-label and active-controlled study, 484 HIV-1 infected antiretroviral naïve adults were randomized and received at least one dose of either dolutegravir 50 mg once daily or darunavir/ritonavir (DRV/r) 800 mg/100 mg once daily, both administered with fixed-dose dual NRTI therapy (either KIVEXA or TRUVADA). Of these subjects, 33% in each group received KIVEXA as background regimen. At baseline, median patient age was 34 years, 15% were female, 28% non-white, 10% had hepatitis B and/or C co-infection, and 3% were CDC Class C, 25% had HIV-1 RNA >100,000 copies/mL, and 35% had CD4+ cell count <350 cells/mm³. These characteristics were similar between treatment groups.

At 48 weeks, there was a statistically significant difference in the proportion of patients achieving virologic suppression (HIV-1 RNA <50 copies/mL) between the group receiving TIVICAY (90%) compared to the darunavir/ritonavir group (83%). The adjusted difference in proportion and 95% CI were 7.1 (0.9, 13.2) (p=0.025). At 96 weeks virologic suppression in the TIVICAY group (80%) remained statistically significant to the darunavir/ritonavir group (68%). The adjusted difference in proportion and 95% CI were 12.4 (4.7, 20.2) (p=0.002). The median time to viral suppression was 28 days in the dolutegravir treatment group and 85 days in the darunavir/ritonavir arm (p<0.001). Response rates at 48 weeks were 90% for TIVICAY + KIVEXA and 85% for darunavir/ritonavir + KIVEXA and at 96 weeks were 82% for TIVICAY + KIVEXA and 75% for darunavir/ritonavir + KIVEXA. The adjusted difference in proportion and 95% CI were 7.3 (-5.4, 20.0). Through 96 weeks, no subjects in the study had treatment-emergent primary resistance mutations.

Pediatrics

The efficacy of the individual components of TRIUMEQ for the treatment of HIV-1 infection was evaluated in pediatric patients aged 12 years and older weighing at least 40 kg in the below pediatric studies of TIVICAY and KIVEXA and is also supported by well-controlled studies of TIVICAY and KIVEXA in adults with HIV-1 infection.

Abacavir and lamivudine were evaluated in a randomized, multicenter trial (ARROW) in HIV-1–infected, treatment-naïve subjects. Subjects randomized to once-daily dosing (n = 336) and who weighed at least 25 kg received abacavir 600 mg and lamivudine 300 mg, as either the single entities or as KIVEXA. At Week 96, 67% of subjects receiving abacavir and lamivudine once-daily had HIV-1 RNA less than 80 copies per mL (See KIVEXA Product Monograph).

Dolutegravir was evaluated in 23 treatment-experienced, INSTI-naïve, HIV-1–infected subjects aged 12 to less than 18 years in a 48-week open-label, multicenter, dose-finding clinical trial, IMPAACT P1093. At 48 weeks, 61% of subjects treated with TIVICAY once daily plus optimized background therapy achieved a viral load less than 50 copies per mL (See TIVICAY Product Monograph).

Comparative Bioavailability Studies

A single-dose, 2-part, crossover study was conducted to evaluate the bioequivalence of an oral 1 x TRIUMEQ (50 mg dolutegravir/600 mg abacavir/300 mg lamivudine) fixed dose combination tablet versus the concurrent oral administration of 1 x Dolutegravir 50 mg tablet plus 1 x EPZICOM (600 mg abacavir/300 mg lamivudine) tablet under fasting conditions (study Part A; n=62) and to evaluate the effect of food on the bioavailability of the fixed dose combination tablet (study Part B: n= 12). The study was conducted in healthy, adult male and female subjects.

EPZICOM (600 mg abacavir/300 mg lamivudine) tablets and the Dolutegravir 50 mg tablets administered as the Reference products in the study are comparable to the commercial Canadian marketed KIVEXA (600 mg abacavir/300 mg lamivudine) tablets and TIVICAY (dolutegravir 50 mg) tablets, respectively.

The TRIUMEQ (50 mg dolutegravir/600 mg abacavir/300 mg lamivudine) fixed dose combination tablet was bioequivalent to Dolutegravir 50 mg tablets plus EPZICOM (abacavir/lamivudine) tablets administered concurrently as separate tablets.

In the separate cohort (n=12), there was no clinically significant effect of a high-fat, high calorie meal on the rate and extent of absorption of dolutegravir, abacavir or lamivudine. These results indicate that TRIUMEQ may be taken with or without food.

Dolutegravir (1 x 50 mg) FASTED CONDITIONS From measured data Geometric Mean Arithmetic Mean (CV %)				
Parameter	Test ¹	Reference ²	% Ratio of Geometric Means	90% Confidence Interval
AUC _T (µg.h/mL)	40.90 42.75 (31)	43.37 45.41 (30)	94.30	(88.80, 100.10)
AUC _I (µg.h/mL)	44.80 47.12 (33)	47.40 49.82 (31)	94.50	(88.90, 100.30)
C _{max} (µg/mL)	2.44 2.53 (28)	2.54 2.64 (28)	96.10	(90.60, 101.90)
T _{max} [§] (h)	3.32 (40)	3.15 (53)		
T _{1/2} [§] (h)	13.00 (21)	13.05 (18)		

1. TRIUMEQ (50 mg dolutegravir / 600 mg abacavir / 300 mg lamivudine) fixed dose combination tablets

2. Dolutegravir 50 mg tablet plus EPZICOM (600 mg abacavir / 300 mg lamivudine) tablet administered concurrently

§ expressed as the arithmetic mean (CV%) only

**Abacavir
(1 x 600 mg)
FASTED CONDITIONS
From measured data
Geometric Mean
Arithmetic Mean (CV %)**

Parameter	Test¹	Reference²	% Ratio of Geometric Means	90% Confidence Interval
AUC _T (µg.h/mL)	13.89 14.32 (25)	14.48 14.87 (23)	96.00	(93.90, 98.00)
AUC _I (µg.h/mL)	13.91 14.35 (25)	14.50 14.89 (23)	96.00	(93.90, 98.00)
C _{max} (µg/mL)	4.02 4.13 (23)	4.37 4.52 (25)	92.00	(86.70, 97.70)
T _{max} [§] (h)	1.73 (49)	1.57 (51)		
T _{1/2} [§] (h)	2.69 (31)	2.63 (28)		

1. TRIUMEQ (50 mg dolutegravir / 600 mg abacavir / 300 mg lamivudine) fixed dose combination tablets
 2. Dolutegravir 50 mg tablet plus EPZICOM (600 mg abacavir / 300 mg lamivudine) tablet administered concurrently
- § expressed as the arithmetic mean (CV%) only

Lamivudine (1 x 300 mg) FASTED CONDITIONS From measured data Geometric Mean Arithmetic Mean (CV %)				
Parameter	Test¹	Reference²	% Ratio of Geometric Means	90% Confidence Interval
AUC _T (µg.h/mL)	12.31 12.70 (26)	12.81 13.10 (21)	96.00	(92.80, 99.40)
AUC _I (µg.h/mL)	12.76 13.13 (25)	13.12 13.41 (21)	97.20	(94.00, 100.50)
C _{max} (µg/mL)	2.11 2.20 (29)	2.28 2.35 (25)	92.60	(88.50, 96.80)
T _{max} [§] (h)	2.74 (32)	2.31 (33)		
T _{1/2} [§] (h)	16.28 (47)	13.74 (39)		

1. TRIUMEQ (50 mg dolutegravir / 600 mg abacavir / 300 mg lamivudine) fixed dose combination tablets
 2. Dolutegravir 50 mg tablet plus EPZICOM (600 mg abavacir / 300 mg lamivudine) tablet administered concurrently
- § expressed as the arithmetic mean (CV%) only

DETAILED PHARMACOLOGY

Microbiology

Antiviral Activity in Cell Culture

Dolutegravir

Dolutegravir exhibited antiviral activity against laboratory strains of wild-type HIV-1 with mean IC₅₀ values of 0.51 nM to 2.1 nM in peripheral blood mononuclear cells (PBMCs) and MT-4 cells.

When dolutegravir was tested in PBMC assays against a panel consisting of 24 HIV-1 clinical isolates [group M (clade A, B, C, D, E, F and G) and group O] and 3 HIV-2 clinical isolates, the geometric mean IC₅₀ was 0.20 nM (0.02 to 2.14 nM) for HIV-1, while the geometric mean IC₅₀ was 0.18 nM (0.09 to 0.61nM) for HIV-2 isolates.

Abacavir

The *in vitro* anti-HIV-1 activity of abacavir was evaluated against a T-cell tropic laboratory strain HIV-1 IIIB in lymphoblastic cell lines, a monocyte/macrophage tropic laboratory strain HIV-1 BaL in primary monocytes/macrophages and clinical isolates in peripheral blood mononuclear cells. The concentration of drug necessary to inhibit viral replication by 50 percent (IC₅₀) ranged from 3.7 to 5.8 µM against HIV-1 IIIB, and was 0.26 ± 0.18 µM (1 µM = 0.28 µg/mL) against eight clinical isolates. The IC₅₀ of abacavir against HIV-1 BaL varied from 0.07 to 1.0 µM. Ribavirin (50µM) had no effect on the anti-HIV-1 activity of abacavir in cell culture.

Lamivudine

The antiviral activity of lamivudine against HIV-1 was assessed in a number of cell lines including monocytes and PBMCs using standard susceptibility assays. IC₅₀ values were in the range of 0.003 µM to 2 µM (1 µM = 0.23 mcg/mL). The IC₅₀ values of lamivudine against different HIV-1 clades (A to G) ranged from 0.001 to 0.120 µM, and against HIV-2 isolates from 0.002 to 0.041 µM in PBMCs. Ribavirin (50µM) decreased the anti-HIV-1 activity of lamivudine by 3.5 fold in MT-4 cells.

Antiviral Activity in combination with other antiviral agents

Dolutegravir

The following drugs were not antagonistic with dolutegravir in *in-vitro* assessments conducted in checkerboard format: stavudine, abacavir, efavirenz, nevirapine, lopinavir, amprenavir, enfuvirtide, maraviroc, adefovir and raltegravir. In addition, the anti-HCV drug ribavirin had no apparent effect on dolutegravir activity.

Abacavir and Lamivudine

No drugs with inherent anti-HIV activity were antagonistic with abacavir/lamivudine; *in vitro* assessments conducted in checkerboard format in combination with the NRTIs emtricitabine, stavudine, tenofovir, zalcitabine, zidovudine; the non-nucleoside reverse transcriptase inhibitors (NNRTIs) delavirdine, efavirenz, nevirapine; the protease inhibitors (PIs) amprenavir, indinavir,

lopinavir, nelfinavir, ritonavir, saquinavir; or the fusion inhibitor, enfuvirtide. Ribavirin decreased the anti-HIV-1 potency of abacavir/lamivudine reproducibly by 2- to 6-fold in cell culture.

Effect of Human Serum and Serum Proteins

In vitro studies suggested a 75-fold shift in IC₅₀ of dolutegravir in the presence of 100% human serum (by method of extrapolation), and the protein adjusted IC₉₀ (PA-IC₉₀) in PBMCs for dolutegravir was estimated to be 0.064 µg/mL. Dolutegravir trough concentration for a single 50 mg dose in integrase inhibitor naïve patients was 1.20 µg/mL, 19 times higher than the estimated PA-IC₉₀. Plasma protein binding studies *in vitro* indicate that abacavir binds only low to moderately (~49%) to human plasma proteins at therapeutic concentrations. Lamivudine exhibits linear pharmacokinetics over the therapeutic dose range and displays low plasma protein binding (less than 36%).

Resistance *in vitro* (dolutegravir)

Isolation from wild type HIV-1

Viruses highly resistant to dolutegravir were not observed during the 112 day passage of strain IIIB, with a 4.1-fold maximum fold change (FC) observed for the passaged resistant virus populations with substitutions at the conserved IN positions S153Y and S153F.

Passage of the wild type HIV-1 strain NL432 in the presence of dolutegravir selected for E92Q (passage population virus FC=3.1) and G193E (passage population virus FC=3.2) substitutions on Day 56. Additional passage of wildtype subtype B, C, and A/G viruses in the presence of dolutegravir selected for R263K, G118R, and S153T.

Resistance *in vitro* (abacavir and lamivudine)

HIV-1 isolates with reduced susceptibility to the combination of abacavir and lamivudine have been selected in cell culture with amino acid substitutions M184V/I, K65R, L74V, and Y115F in HIV-1 RT. Resistance to lamivudine was due to a specific amino acid substitution at codon 184 changing the methionine to either isoleucine or valine (M184V/I). The substitution at M184I/V causes high-level resistance to lamivudine and approximately three-fold decreased susceptibility to abacavir, below the clinical cutoff for abacavir (4.5-fold). An additional substitution from abacavir resistance positions K65R, L74M, or Y115F conferred a 7- fold to 8-fold change (above the clinical cutoff) in abacavir susceptibility, and combinations of three substitutions were required to confer more than an 8-fold change in susceptibility.

Resistance *in vivo* (dolutegravir)

Integrase inhibitor naïve patients

No INI-resistant substitutions or treatment emergent resistance to the NRTI backbone therapy were isolated with dolutegravir 50 mg once daily in treatment-naïve studies (SPRING-2, SINGLE and FLAMINGO studies).

Resistance *in vivo* (abacavir and lamivudine)

HIV-1 isolates with reduced susceptibility to the combination of abacavir and lamivudine have been obtained from subjects failing abacavir/lamivudine-containing regimens. Resistance analyses of virologic failure isolates for subjects receiving abacavir/lamivudine therapy showed that the RT substitutions that emerged were those observed *in vitro* (K65R, L74V, Y115F, and M184V/I), with the abacavir and lamivudine-associated resistance substitution M184V/I being most commonly observed.

Resistance testing was performed on samples from subjects failing treatment with dolutegravir + KIVEXA in the treatment-naïve trials: SINGLE (n = 414 treated through 96 weeks), SPRING-2 (n = 169 treated through 96 weeks), and FLAMINGO (n = 79 treated through 48 weeks). Of these, 34 subjects met resistance testing criteria: 25 from SINGLE, 9 from SPRING-2 and none from FLAMINGO. Of these, 23 had both baseline and on study resistance testing data; there were no treatment-emergent RT substitutions isolated in the subjects receiving dolutegravir + KIVEXA.

Anti-HIV Activity Against Resistant Strains

Reverse Transcriptase Inhibitor- and Protease Inhibitor-Resistant Strains: Dolutegravir demonstrated equivalent antiviral activity against 2 non-nucleoside (NN)-RTI-resistant, 3 nucleoside (N)-RTI-resistant, and 2 PI-resistant HIV-1 mutant clones (1 triple and 1 sextuple) compared to the wildtype strain.

Integrase Inhibitor-Resistant HIV-1 Strains

Sixty integrase inhibitor-resistant mutant HIV-1 viruses (28 with single substitutions and 32 with 2 or more substitutions) were produced from wild-type virus NL-432 using site-directed mutagenesis. Dolutegravir showed anti-HIV activity (susceptibility) with FC < 5 against 27 of 28 integrase inhibitor-resistant mutant viruses with single substitutions including T66A/I/K, E92Q/V, Y143C/H/R, Q148H/K/R, and N155H, while for raltegravir and elvitegravir there were 17/28 and 11/21 tested mutant viruses with FC < 5, respectively. In addition, of the 32 integrase inhibitor-resistant mutant viruses with 2 or more substitutions, 23 of 32 showed FC < 5 to dolutegravir compared with FC < 5 for 4 of 32 for raltegravir and FC < 5 for 2 of 25 tested for elvitegravir.

Integrase Inhibitor-Resistant HIV-2 Strains

Site directed mutant HIV-2 viruses were constructed based on patients infected with HIV-2 and treated with raltegravir who showed virologic failure (n=6). Overall the HIV-2 FCs observed were similar to HIV-1 FCs observed for similar pathway mutations. Dolutegravir FC was <5 against 4 HIV-2 viruses (S163D, G140A/Q148R, A153G/N155H/S163G and E92Q/T97A/N155H/S163D); for E92Q/N155H, dolutegravir FC was 8.5, and for G140S/Q148R, dolutegravir FC was 17. Dolutegravir, raltegravir and elvitegravir all had had the same activity against site directed mutant HIV-2 with S163D as wildtype, and for the remaining mutant HIV-2 virus raltegravir FC ranges were 6.4 to 420 and elvitegravir FC ranges were 22 to 640.

Abacavir and Lamivudine

Cross resistance between abacavir or lamivudine and antiretrovirals from other classes (e.g. protease inhibitors (PI) or non-nucleoside reverse transcriptase inhibitors (NNRTIs)), is unlikely. Reduced susceptibility to abacavir has been demonstrated in clinical isolates of patients with uncontrolled viral replication, who have been pre-treated with and are resistant to other nucleoside inhibitors.

Clinical isolates with three or more mutations associated with NRTIs are unlikely to be susceptible to abacavir. Cross resistance conferred by the M184V RT is limited within the nucleoside inhibitor class of antiretroviral agents. Zidovudine, stavudine, abacavir and tenofovir maintain their antiretroviral activities against lamivudine-resistant HIV-1 harbouring only the M184V mutation.

In vitro isolates resistant to abacavir might also show reduced sensitivity to lamivudine, zalcitabine, tenofovir, emtricitabine and/or didanosine, but remain sensitive to zidovudine and stavudine

Pharmacokinetics

The drug interaction studies that are described were conducted with dolutegravir, abacavir, and/or lamivudine; no drug interaction trials have been conducted using TRIUMEQ. Due to different routes of metabolism and elimination, and the minimal effect of these agents on drug metabolizing enzymes or transporters, no clinically significant drug interactions are expected between dolutegravir, abacavir, and lamivudine.

As dolutegravir is not expected to affect the pharmacokinetics of other drugs dependent on hepatic metabolism (Table 8), the primary focus of the drug interaction studies was to evaluate the effect of co-administered drug (Table 9).

Dosing recommendations as a result of established and other potentially significant drug-drug interactions with TRIUMEQ are provided in Table 4.

Table 8 Summary of Effect of Dolutegravir on the Pharmacokinetics of Co-administered Drugs

Coadministered Drug(s) and Dose(s)	Dose of TIVICAY	n	Geometric Mean Ratio (90% CI) of Pharmacokinetic Parameters of Coadministered Drug With/Without Dolutegravir No Effect = 1.00		
			C _t or C ₂₄	AUC	C _{max}
Ethinyl estradiol 0.035 mg	50 mg twice daily	15	1.02 (0.93, 1.11)	1.03 (0.96, 1.11)	0.99 (0.91, 1.08)
Methadone 20 to 150 mg	50 mg twice daily	12	0.99 (0.91, 1.07)	0.98 (0.91, 1.06)	1.00 (0.94, 1.06)
Midazolam 3 mg	25 mg once daily	10	–	0.95 (0.79, 1.15)	–
Norgestimate 0.25 mg	50 mg twice daily	15	0.93 (0.85, 1.03)	0.98 (0.91, 1.04)	0.89 (0.82, 0.97)
Rilpivirine 25 mg once daily	50 mg once daily	16	1.21 (1.07, 1.38)	1.06 (0.98, 1.16)	1.10 (0.99, 1.22)
Tenofovir disoproxil fumarate 300 mg once daily	50 mg once daily	16	1.19 (1.04, 1.35)	1.12 (1.01, 1.24)	1.09 (0.97, 1.23)
Metformin 500 mg twice daily	50 mg once daily	14	–	1.79 (1.65, 1.93)	1.66 (1.53, 1.81)
Metformin 500 mg twice daily	50 mg twice daily	14	–	2.45 (2.25, 2.66)	2.11 (1.91, 2.33)

Table 9 Summary of Effect of Co-administered Drugs on the Pharmacokinetics of Dolutegravir

Coadministered Drug(s) and Dose(s)	Dose of TIVICAY	n	Geometric Mean Ratio (90% CI) of Dolutegravir Pharmacokinetic Parameters With/Without Coadministered Drugs No Effect = 1.00		
			C _r or C ₂₄	AUC	C _{max}
Atazanavir 400 mg once daily	30 mg once daily	12	2.80 (2.52, 3.11)	1.91 (1.80, 2.03)	1.50 (1.40, 1.59)
Atazanavir/ritonavir 300/100 mg once daily	30 mg once daily	12	2.21 (1.97, 2.47)	1.62 (1.50, 1.74)	1.34 (1.25, 1.42)
Tenofovir 300 mg once daily	50 mg once daily	15	0.92 (0.82, 1.04)	1.01 (0.91, 1.11)	0.97 (0.87, 1.08)
Darunavir/ritonavir 600/100 mg twice daily	30 mg once daily	15	0.62 (0.56, 0.69)	0.78 (0.72, 0.85)	0.89 (0.83, 0.97)
Efavirenz 600 mg once daily	50 mg once daily	12	0.25 (0.18, 0.34)	0.43 (0.35, 0.54)	0.61 (0.51, 0.73)
Etravirine 200 mg twice daily.	50 mg once daily	15	0.12 (0.09, 0.16)	0.29 (0.26, 0.34)	0.48 (0.43, 0.54)
Etravirine + darunavir/ritonavir 200 mg + 600/100 mg twice daily	50 mg once daily	9	0.63 (0.52, 0.76)	0.75 (0.69, 0.81)	0.88 (0.78, 1.00)
Etravirine + lopinavir/ritonavir 200 mg + 400/100 mg twice daily	50 mg once daily	8	1.28 (1.13, 1.45)	1.11 (1.02, 1.20)	1.07 (1.02, 1.13)
Fosamprenavir/ritonavir 700 mg + 100 mg twice daily	50 mg once daily	12	0.51 (0.41, 0.63)	0.65 (0.54, 0.78)	0.76 (0.63, 0.92)
Lopinavir/ritonavir 400/100 mg twice daily	30 mg once daily	15	0.94 (0.85, 1.05)	0.97 (0.91, 1.04)	1.00 (0.94, 1.07)
Maalox	50 mg single dose	16	0.26 (0.21, 0.31)	0.26 (0.22, 0.32)	0.28 (0.23, 0.33)
Maalox 2 hrs after dolutegravir	50 mg single dose	16	0.70 (0.58, 0.85)	0.74 (0.62, 0.90)	0.82 (0.69, 0.98)
Calcium Carbonate 1200mg Simultaneous administration (fasted)	50 mg single dose	12	0.61 (0.47, 0.80)	0.61 (0.47, 0.79)	0.63 (0.50, 0.81)
Calcium Carbonate 1200mg Simultaneous administration (fed)	50 mg single dose	11	1.08 (0.81, 1.42)	1.09 (0.84, 1.43)	1.07 (0.83, 1.38)
Calcium Carbonate 1200mg 2 hrs prior to dolutegravir	50 mg single dose	11	0.90 (0.68, 1.19)	0.94 (0.72, 1.23)	1.00 (0.7, 1.29)

Coadministered Drug(s) and Dose(s)	Dose of TIVICAY	n	Geometric Mean Ratio (90% CI) of Dolutegravir Pharmacokinetic Parameters With/Without Coadministered Drugs No Effect = 1.00		
			C _τ or C ₂₄	AUC	C _{max}
Ferrous Fumarate 324 mg Simultaneous administration (fasted)	50 mg single dose	11	0.44 (0.36, 0.54)	0.46 (0.38, 0.56)	0.43 (0.35, 0.52)
Ferrous Fumarate 324 mg Simultaneous administration (fed)	50 mg single dose	11	0.99 (0.80, 1.22)	0.97 (0.80, 1.19)	1.03 (0.85, 1.26)
Ferrous Fumarate 324 mg 2 hrs prior to dolutegravir	50 mg single dose	10	0.92 (0.74, 1.13)	0.95 (0.78, 1.15)	0.99 (0.81, 1.21)
Multivitamin One tablet once daily	50 mg single dose	16	0.68 (0.56, 0.82)	0.67 (0.55, 0.81)	0.65 (0.54, 0.77)
Omeprazole 40 mg once daily	50 mg single dose	12	0.95 (0.75, 1.21)	0.97 (0.78, 1.20)	0.92 (0.75, 1.11)
Prednisone 60 mg once daily with taper	50 mg once daily	12	1.17 (1.06, 1.28)	1.11 (1.03, 1.20)	1.06 (0.99, 1.14)
Rifampin ^a 600 mg once daily	50 mg twice daily ^a	11	0.28 (0.23, 0.34)	0.46 (0.38, 0.55)	0.57 (0.49, 0.65)
Rifampin ^b 600 mg once daily	50 mg twice daily ^b	11	1.22 (1.01, 1.48)	1.33 (1.15, 1.53)	1.18 (1.03, 1.37)
Rifabutin 300 mg once daily	50 mg once daily	9	0.70 (0.57, 0.87)	0.95 (0.82, 1.10)	1.16 (0.98, 1.37)
Rilpivirine 25 mg once daily	50 mg once daily	16	1.22 (1.15, 1.30)	1.12 (1.05, 1.19)	1.13 (1.06, 1.21)
Tipranavir/ritonavir 500/200 mg twice daily	50 mg once daily	14	0.24 (0.21, 0.27)	0.41 (0.38 to 0.44)	0.54 (0.50 to 0.57)
Telaprevir 750 mg every 8 hours	50 mg once daily	15	1.37 (1.29, 1.45)	1.25 (1.20, 1.31)	1.18 (1.11, 1.26)
Boceprevir 800 mg every 8 hours	50 mg once daily	13	1.08 (0.91, 1.28)	1.07 (0.95, 1.20)	1.05 (0.96, 1.15)
Carbamazepine 300 mg twice daily	50 mg once daily	14	0.27 (0.24, 0.31)	0.51 (0.48, 0.55)	0.67 (0.61, 0.73)

^a Comparison is rifampin taken with dolutegravir 50 mg twice daily compared with dolutegravir 50 mg twice daily.

^b Comparison is rifampin taken with dolutegravir 50 mg twice daily compared with dolutegravir 50 mg once daily.

TOXICOLOGY

With the exception of a negative *in vivo* rat micronucleus test for the combination of abacavir and lamivudine, there are no data available on the effects of the combination of dolutegravir, abacavir and lamivudine in animals.

Carcinogenesis/mutagenesis

Dolutegravir was not mutagenic or clastogenic using *in vitro* tests in bacteria and cultured mammalian cells, and an *in vivo* rodent micronucleus assay. Dolutegravir was not carcinogenic in long term studies in the mouse and rat at exposures ~26 and ~23 times, respectively, above the human clinical exposure based on AUC at the recommended dose of 50 mg dolutegravir.

Neither abacavir nor lamivudine were mutagenic in bacterial tests, but like many nucleoside analogues they show activity in the *in vitro* mammalian tests such as the mouse lymphoma assay. This is consistent with the known activity of other nucleoside analogues. The results of an *in vivo* rat micronucleus test with abacavir and lamivudine in combination were negative.

Carcinogenicity studies with orally administered abacavir in mice and rats showed an increase in the incidence of malignant and non-malignant tumours. Malignant tumours occurred in the preputial gland of males and the clitoral gland of females of both species, and in the liver, urinary bladder, lymph nodes and the subcutis of female rats.

The majority of these tumours occurred at the highest abacavir dose of 330 mg/kg/day in mice and 600 mg/kg/day in rats. These dose levels were equivalent to 21 to 28 times above the human clinical exposure based on AUC at the recommended dose of 600 mg abacavir. The exception was the preputial gland tumour which occurred at a dose of 110 mg/kg. This is equivalent to six times the expected human systemic exposure. There is no structural counterpart for this gland in humans. While the carcinogenic potential in humans is unknown, these data suggest that a carcinogenic risk to humans is outweighed by the potential clinical benefit.

In *in-vivo* studies, long-term carcinogenicity studies with lamivudine in mice and rats showed no evidence of carcinogenic potential at exposures up to 12 times (mice) and 72 times (rats) above the human clinical exposure based on AUC at the recommended dose of 300 mg lamivudine.

Abacavir induced chromosomal aberrations both in the presence and absence of metabolic activation in an *in vitro* cytogenetic study in human lymphocytes. Abacavir was mutagenic in the absence of metabolic activation, although it was not mutagenic in the presence of metabolic activation in an L5178Y mouse lymphoma assay. At systemic exposures approximately nine times higher than those in humans at the therapeutic dose, abacavir was clastogenic in males and not clastogenic in females in an *in vivo* mouse bone marrow micronucleus assay. Abacavir was not mutagenic in bacterial mutagenicity assays in the presence and absence of metabolic activation.

Lamivudine was not active in a microbial mutagenicity screen or an *in vitro* cell transformation assay, but showed weak *in vitro* mutagenic activity in a cytogenetic assay using cultured human lymphocytes and in the mouse lymphoma assay. However, lamivudine showed no evidence of *in vivo* genotoxic activity in the rat at oral doses of up to 2,000 mg/kg, approximately 65 times the recommended human dose.

Reproductive Toxicology

Fertility: Fertility studies in the rat have shown that dolutegravir, abacavir and lamivudine had no effect on male or female fertility.

Dolutegravir did not affect male or female fertility in rats at doses up to 1000 mg/kg/day, the highest dose tested (44 times above the human clinical exposure based on AUC at the recommended dose of 50 mg dolutegravir, 600 mg abacavir, and 300 mg lamivudine).

Pregnancy: In reproductive toxicity studies in animals, dolutegravir, abacavir and lamivudine were shown to cross the placenta.

Dolutegravir

Oral administration of dolutegravir to pregnant rats at doses up to 1000 mg/kg daily from days 6 to 17 of gestation did not elicit maternal toxicity, developmental toxicity or teratogenicity (50 times above the human clinical exposure based on AUC at the recommended dose of 50 mg dolutegravir, 600 mg abacavir, and 300 mg lamivudine).

Oral administration of dolutegravir to pregnant rabbits at doses up to 1000 mg/kg daily from days 6 to 18 of gestation did not elicit developmental toxicity or teratogenicity (0.74 times the human clinical exposure based on AUC at the recommended dose of 50 mg dolutegravir, 600 mg abacavir, and 300 mg lamivudine). In rabbits, maternal toxicity (decreased food consumption, scant/no faeces/urine, suppressed body weight gain) was observed at 1000 mg/kg (0.74 times the human clinical exposure based on AUC at the recommended dose of 50 mg dolutegravir, 600 mg abacavir, and 300 mg lamivudine).

Abacavir

Reproduction studies were performed in rats and rabbits at orally administered doses up to 1,000 mg/kg/day and 700 mg/kg/day, respectively. These doses in rats and rabbits achieved approximately 28 and 7 times, respectively, above the human clinical exposure based on AUC at the recommended dose of 50 mg dolutegravir, 600 mg abacavir, and 300 mg lamivudine. In the rat, development toxicity (depressed fetal body weight and reduced crown-rump length) and increased incidences of fetal anasarca and skeletal malformations were observed at the highest dose assessed. Studies in pregnant rats showed that abacavir is transferred to the fetus through the placenta. In a fertility study, evidence of toxicity to the developing embryo and fetuses (increased resorptions, decreased fetal body weights) occurred only at 500 mg/kg/day, a dose that was toxic to the parental generation. The offspring of female rats treated with abacavir at 500 mg/kg (beginning at embryo implantation and ending at weaning) showed increased incidence of stillbirth and lower body weights throughout life.

Lamivudine

Lamivudine was not teratogenic in the rat or rabbit, at doses up to 2,000 mg/kg b.i.d. and 500 mg/kg b.i.d., respectively. In the rabbit a slight increase in the incidence of pre-implantation loss at doses 20 mg/kg b.i.d. and above indicates a possible early embryo-lethal effect. There was no such effect in the rat. These marginal effects occurred at relatively low doses, which produced plasma levels comparable to those achieved in patients.

In a peri-/post-natal/juvenile toxicity study in rats, some histological inflammatory changes at the ano-rectal junction and slight diffuse epithelial hyperplasia of the cecum were observed in dams and pups at the high-dose level. An increased incidence of urination upon handling was also seen in some offspring receiving 450 or 2,000 mg/kg. In addition, a reduction in testes weight was observed in juvenile males at 2,000 mg/kg which was associated with slight to moderate dilatation of the seminiferous tubules.

Animal toxicology and/or pharmacology

Dolutegravir

The effect of prolonged daily treatment with high doses of dolutegravir has been evaluated in repeat oral dose toxicity studies in rats (up to 26 weeks) and in monkeys (up to 38 weeks). The primary effect of dolutegravir was gastrointestinal intolerance or irritation in rats and monkeys at doses that produce systemic exposures approximately 38 and 1.5 times above the human clinical exposure based on AUC at the recommended dose of 50 mg dolutegravir, 600 mg abacavir, and 300 mg lamivudine. Because gastrointestinal (GI) intolerance is considered to be due to local drug administration, mg/kg or mg/m² metrics are appropriate determinates of safety cover for this toxicity. GI intolerance in monkeys occurred at 30 times the human mg/kg equivalent dose (based on 50 kg human), and 11 times the human mg/m² equivalent dose for a total daily clinical dose of 50 mg. Dolutegravir was slightly to mildly irritating to skin and eyes in the rabbit.

Mild myocardial degeneration in the heart of mice and rats was observed following administration of abacavir for two years. The systemic exposures were equivalent to 7 to 21 times above the human clinical exposure based on AUC at the recommended dose of 50 mg dolutegravir, 600 mg abacavir, and 300 mg lamivudine. The clinical relevance of this finding has not been determined.

For additional information on Toxicology, please consult the individual product monographs of TIVICAY, KIVEXA, 3TC, and ZIAGEN.

REFERENCES

1. Cammack N, Rouse P, Marr CL, Reid PJ, Boehme RE, Coates JA et al. Cellular metabolism of (-) enantiomeric 2'-deoxy-3'-thiacytidine. *Biochem Pharmacol* 1992; 43(10):2059-2064.
2. Chen S, Min SS, Peppercorn A, et al. Effect of a single supratherapeutic dose of dolutegravir on cardiac repolarization. *Pharmacotherapy*. 2012; 32(4): 333-339.
3. Daluge SM, Good SS, Faletto MB, Miller WH, St Clair MH, Boone LR et al. 1592U89, a novel carbocyclic nucleoside analog with potent, selective anti-human immunodeficiency virus activity. *Antimicrob Agents Chemother* 1997; 41(5):1082-1093.
4. Dooley KE, Sayre P, Borland J, et al. Safety, tolerability, and pharmacokinetics of the HIV integrase inhibitor dolutegravir given twice daily with rifampin or once daily with rifabutin: results of a phase 1 study among healthy subjects. *J Acquir Immune Defic Syndr*. 2013 Jan; 62(1): 21-27.
5. Harris M, Back D, Kewn S, Jutha S, Marina R, Montaner J. Intracellular carbovir triphosphate levels in patients taking abacavir once a day. *AIDS* 2002; 16(8):1196-1197.
6. Hart GJ, Orr DC, Penn CR, Figueiredo HT, Gray NM, Boehme RE et al. Effects of (-)-2'-deoxy-3'-thiacytidine (3TC) 5'-triphosphate on human immunodeficiency virus reverse transcriptase and mammalian DNA polymerases alpha, beta, and gamma. *Antimicrob Agents Chemother* 1992; 36(8):1688-1694.
7. Hetherington S, McGuirk S, Powell G, Cutrell A, Naderer O, Spreen B et al. Hypersensitivity reactions during therapy with the nucleoside reverse transcriptase inhibitor abacavir. *Clin Ther* 2001 Oct; 23(10): 1603-1614.
8. Hightower KE, Wang R, Deanda F, et al. Dolutegravir (S/GSK1349572) Exhibits Significantly Slower Dissociation than Raltegravir and Elvitegravir from Wild-Type and Integrase Inhibitor-Resistant HIV-1 Integrase-DNA Complexes. *Antimicrobial Agents and Chemotherapy*, Oct. 2011; 55(10): 4552–4559.
9. Hughes DA, Vilar FJ, Ward CC, Alfirevic A, Park BK, Pirmohamed M. Cost-effectiveness analysis of HLA B*5701 genotyping in preventing abacavir hypersensitivity. *Pharmacogenetics* 2004 Jun; 14(6): 335-342.
10. Koteff J, Borland J, Chen S, et al. A phase 1 study to evaluate dolutegravir's effect on renal function via measurement of iohexol and para-aminohippurate clearance in healthy subjects. *Br J Clin Pharmacol*. 2013 April; 75(4): 990-996.
11. Mallal S, Phillips E, Carosi G, Molina JM, Workman C, et al. PREDICT-1 Study Team. HLA-B*5701 screening for hypersensitivity to abacavir. *N Engl J Med*. 2008 Feb; 358(6):568-79.

12. Mesplède T, Quashie PK, Osman N, Han Y, Singhroy DN et al. Viral fitness cost prevents HIV-1 from evading dolutegravir drug pressure. *Retrovirology*. 2013 Feb 22; 10:22.
13. Moyle G, Boffito M, Fletcher C, Higgs C, Hay PE, et al. Steady-state pharmacokinetics of abacavir in plasma and intracellular carbovir triphosphate following administration of abacavir at 600 milligrams once daily and 300 milligrams twice daily in human immunodeficiency virus-infected subjects. *Antimicrob Agents Chemother*. 2009 Apr; 53(4):1532-8.
14. Quashie PK, Mesplede T, Han YS, et al. Characterization of the R263K mutation in HIV-1 integrase that confers low-level resistance to the second-generation integrase strand transfer inhibitor dolutegravir. *J Virol*. 2012 Mar; 86(5): 2696-705.
15. Raffi F, Rachlis A, Stellbrink HJ, Hardy W D, Torti C, Orkin C, Bloch M, Podzamczar D et al. Once-daily dolutegravir versus raltegravir in antiretroviral naïve adults with HIV-1 infection: 48 week results from the randomised, double-blind, non-inferiority SPRING-2 study. *Lancet* 2013 March; 381(9868):735-743.
16. Raffi F, Jaeger H, Quiros-Roldan E, et al. Once-daily dolutegravir versus twice-daily raltegravir in antiretroviral-naïve adults with HIV-1 infection (SPRING-2 study): 96 week results from a randomised, double-blind, non-inferiority trial. *Lancet Infect Dis*. 2013 Nov; 13(11): 927-935.
17. Reese MJ, Savina PM, Generaux GT, et al. In vitro investigations into the roles of drug transporters and metabolizing enzymes in the disposition and drug interactions of dolutegravir, a HIV integrase inhibitor. *Drug Metab Dispos*. 2013 Feb; 41(2):353-361.
18. Rhodes MC, Laffan S, Genell C, et al. Assessing a theoretical risk of dolutegravir-induced developmental immunotoxicity in juvenile rats. *Toxicol Sci*. 2012 Nov; 130(1): 70-81.
19. Song I, Borland J, Chen S, et al. Effect of food on the pharmacokinetics of the integrase inhibitor dolutegravir. *Antimicrob Agents Chemother*. 2012; 56(3):1627-1629.
20. Stellbrink HJ, Reynes J, Lazzarin A et al. Dolutegravir in antiretroviral-naïve adults with HIV-1: 96 Week results from the randomized SPRING-1 trial. *AIDS* 2013; 27(11): 1771-1778.
21. Tisdale M, Alnadaf T, Cousens D. Combination of mutations in human immunodeficiency virus type 1 reverse transcriptase required for resistance to the carbocyclic nucleoside 1592U89. *Antimicrob Agents Chemother* 1997; 41(5):1094-1098.
22. Walmsley S, Antela A, Clumeck N, et.al. Dolutegravir plus Abacavir/Lamivudine for the Initial Treatment of HIV-1 Infection. *New England Journal of Medicine* 2013 Nov; 369(19): 1807-1818.

23. Weller S, Borland J, Chen S, et al. Pharmacokinetics of dolutegravir in HIV-seronegative subjects with severe renal impairment. *Eur J Clin Pharmacol*. 2013 Oct 6. [Epub ahead of print]
24. Yuen GJ, Lou Y, Bumgarner NF, Bishop JP, Smith GA, Otto VR et al. Equivalent steady-state PKs of lamivudine in plasma and lamivudine triphosphate within cells following administration of lamivudine at 300 milligrams once daily and 150 milligrams twice daily. *Antimicrob Agents Chemother*. 2004; 48(1):176-182.
25. Zucman D, Truchis P, Majerholc C, Stegman S, Caillat-Zucman S. Prospective screening for human leukocyte antigen-B*5701 avoids abacavir hypersensitivity reaction in the ethnically mixed French HIV population. *J Acquir Immune Defic Syndr* 2007 May 1; 45(1): 1-3.
26. vanLunzen J, Maggiolo F, Arribas J, et al. Once daily dolutegravir (S/GSK1349572) in combination therapy in antiretroviral-naive adults with HIV: planned interim 48 week results from SPRING-1, a dose-ranging, randomised, phase 2b trial. *Lancet Infect Dis*. 2012; 12(2):111-118.

PART III: CONSUMER INFORMATION

Pr TRIUMEQ dolutegravir, abacavir, and lamivudine tablets

This leaflet is part III of a three-part "Product Monograph" published when TRIUMEQ was approved for sale in Canada and is designed specifically for Consumers. This leaflet is a summary and will not tell you everything about TRIUMEQ. Please read this leaflet carefully before you start to take your medicine. You may need to read this leaflet again during your treatment. Contact your doctor or pharmacist if you have any questions about the drug.

ABOUT THIS MEDICATION

What the medication is used for:

TRIUMEQ is a prescription oral tablet used for treatment of HIV (Human Immunodeficiency Virus) infection in adults and children (12 years and older) weighing at least 40 kg. TRIUMEQ contains three medicines combined in one pill: dolutegravir, abacavir, and lamivudine. Dolutegravir belongs to a group of anti-retroviral medicines called integrase inhibitors (INIs). Abacavir and lamivudine belong to a group of anti-retroviral medicines called nucleoside analogues reverse transcriptase inhibitors (NRTIs).

The Human Immunodeficiency Virus (HIV) is a retrovirus (a type of virus). Infection with HIV damages the immune system and can lead to Acquired Immune Deficiency Syndrome (AIDS) and other related illnesses.

What it does:

TRIUMEQ is not a cure for HIV infection or AIDS; it reduces the amount of virus in your body, and keeps it at a low level. TRIUMEQ also increases the CD4 cell count in your blood. CD4 cells are white blood cells that are important in helping your body to fight infection.

- TRIUMEQ will not stop you from passing HIV to others, although this risk is lower if you take your HIV medicine as instructed by your healthcare professional. You should take steps to avoid this by: using condoms when you have oral or penetrative sex, not reusing or sharing needles, syringes, or other injection equipment.

When it should not be used:

Do not take TRIUMEQ if you are:

- allergic to dolutegravir, abacavir sulfate or

lamivudine, or any of the ingredients in TRIUMEQ (see **What the important nonmedicinal ingredients are** for a complete list of ingredients in TRIUMEQ.)

- positive for the HLA-B*5701 gene variation
- taking dofetilide to treat heart conditions,
- taking fampridine (also known as dalfampridine) to treat multiple sclerosis)

What the medicinal ingredient is:

Each TRIUMEQ tablet contains 50 mg dolutegravir (as dolutegravir sodium), 600 mg of abacavir (as abacavir sulfate) and 300 mg lamivudine.

What the important nonmedicinal ingredients are:

D-mannitol, magnesium stearate, microcrystalline cellulose, povidone K29/32, and sodium starch glycolate. The tablet film-coating (OPADRY® II Purple 85F90057) contains the inactive ingredients iron oxide black, iron oxide red, macrogol/PEG, polyvinyl alcohol–part hydrolyzed, talc, and titanium dioxide.

What dosage forms it comes in:

TRIUMEQ is available as purple, oval, film-coated tablets engraved with "572 Tri" on one side and plain on the other.

WARNINGS AND PRECAUTIONS

Serious Warnings and Precautions

Hypersensitivity Reactions

You should be screened for the HLA-B*5701 gene variation prior to starting or re-starting treatment with TRIUMEQ. Patients who have the HLA-B*5701 gene variation have a high risk of developing a hypersensitivity reaction (serious allergic reaction) to abacavir, which is in the drug TRIUMEQ. This hypersensitivity reaction **can be life threatening** if you continue to take TRIUMEQ (see **Important Information on Hypersensitivity Reactions**).

Worsening of hepatitis B virus in people who have HIV-1 infection

If you have a hepatitis B infection, you should not stop taking TRIUMEQ without instructions from your doctor as your hepatitis may worsen or reoccur. Your doctor will monitor your conditions for several months after stopping treatment with TRIUMEQ.

Important Information on Hypersensitivity Reactions

If you get two or more of the following groups of symptoms while taking TRIUMEQ, contact your doctor immediately to find out if you should stop taking TRIUMEQ:

	SYMPTOM(S)
Group 1	Fever
Group 2	Rash
Group 3	Nausea, vomiting, diarrhea, or abdominal (stomach area) pain
Group 4	Generally ill feeling, extreme tiredness or achiness
Group 5	Shortness of breath, cough or sore throat

A list of these symptoms is on the Warning Card provided by your pharmacist. You should carry this Warning Card with you at all times. **If you notice these symptoms while taking TRIUMEQ, call your doctor immediately. Your doctor may advise you to stop taking TRIUMEQ.**

If you stop TRIUMEQ because of a serious allergic reaction, never take TRIUMEQ or any other medicine containing abacavir or dolutegravir (such as ZIAGEN, KIVEXA, TRIZIVIR, or TIVICAY) again, regardless of whether you have the HLA-B*5701 gene variation or not. Within hours you may experience a life threatening lowering of your blood pressure or death. If you stop TRIUMEQ for any other reason, even for a few days, and you are not allergic to TRIUMEQ, talk with your doctor before taking it again. Taking TRIUMEQ again may cause a serious allergic or life-threatening reaction, even if you never had an allergic reaction to it before.

If your healthcare provider tells you that you can take TRIUMEQ again, start taking it when you are around medical help or people who can call a doctor if you need one.

BEFORE you use TRIUMEQ talk to your doctor or pharmacist:

- If you have had previous use of any NRTI class medicine.
- If you have been tested and know whether or not you have a gene variation called HLA-B*5701
- If you have kidney or liver problems, including hepatitis B or C
- If you could get pregnant. While taking TRIUMEQ use a reliable method of contraception to prevent pregnancy.
- If you are pregnant or plan to become pregnant; do not take TRIUMEQ without speaking with your doctor first. Babies and infants exposed to medicines containing Nucleoside Reverse Transcriptase Inhibitors (NRTIs) during pregnancy

or labour show minor temporary increases in blood levels of lactate. There have also been very rare reports of disease that affect babies' nervous systems such as delayed development and seizures. These findings do not affect current recommendations to use antiretroviral therapy in pregnant women to prevent transmission of HIV to their babies. Your doctor will consider the benefit to you and the risk to your baby when taking TRIUMEQ while pregnant. If you take TRIUMEQ while you are pregnant, talk to your doctor about how you can be included in the Antiretroviral Pregnancy Registry.

- Taking TRIUMEQ at the time of becoming pregnant, or during the first 12 weeks of pregnancy, may increase the risk of a type of birth defect, called neural tube defect, such as spina bifida (malformed spinal cord).
- If you are breastfeeding or plan to breastfeed. Where possible, women who are HIV positive should not breastfeed, because HIV infection can pass into breast milk and harm your baby. Abacavir and lamivudine, components of TRIUMEQ, can pass into breast milk. Talk to your doctor about how to feed your infant
- If you have any other medical condition
- About all your medicines you are taking including vitamins, herbal supplements and non-prescription drugs

Other special warnings

Your blood sugar levels (glucose) or levels of fats (lipids) in your blood may increase with HIV treatment. Your doctor may order blood tests for you.

Two components of TRIUMEQ (abacavir sulfate and lamivudine) belong to a class of medicines (NRTIs) that can cause a condition called lactic acidosis (excess of lactic acid in your blood), together with an enlarged liver. Symptoms of lactic acidosis include feeling of weakness, loss of appetite, sudden unexplained weight loss, upset stomach and difficulty breathing or rapid breathing. This rare but serious side effect occurs more often in women. If you have liver disease you may also be more at risk of getting this condition. While you are being treated with TRIUMEQ your doctor will monitor you closely for any signs that you may be developing lactic acidosis.

If you have hepatitis B infection, you should not stop TRIUMEQ without instructions from your doctor, as you may have recurrence of your hepatitis. This may occur due to you suddenly stopping the active ingredient lamivudine in TRIUMEQ.

Serious liver problems including liver injury and liver

failure have been seen in people taking TRIUMEQ. In some cases the liver injury has led to needing a liver transplant. Symptoms of liver problems include yellowing of the skin or whites of the eyes, dark or tea coloured urine, pale coloured stools/ bowel movements, nausea/ vomiting, loss of appetite, pain, aching or tenderness on right side below the ribs. While you are being treated with TRIUMEQ your doctor will monitor you closely for any signs of liver problems.

Some HIV medicines including abacavir may increase your risk of heart attack. If you have heart problems, smoke or suffer from diseases that increase your risk of heart disease such as high blood pressure and diabetes, tell your doctor. Do not stop taking your medication unless you are advised to do so by your doctor.

You may continue to develop other infections and other illnesses associated with HIV disease. You should therefore keep in regular contact with your doctor while taking TRIUMEQ.

Remember: This medicine is for you. Never give it to someone else. It may harm them even if their symptoms are the same as yours.

INTERACTIONS WITH THIS MEDICATION

No drug interaction studies have been done with the fixed dose combination, TRIUMEQ. Tell your healthcare provider about all prescription and non-prescription medications listed below or any that you are taking; including any vitamins, herbal supplements, and dietary supplements. Some drugs may interact with TRIUMEQ and can affect how TRIUMEQ works, or make it more likely that you will have side effects. These include:

- metformin, to treat diabetes
- medicines called antacids, to treat indigestion and heartburn. Do not take an antacid during the 6 hours before you take TRIUMEQ, or for at least 2 hours after you take it.
- calcium or iron supplements. Do not take these supplements during the 6 hours before you take TRIUMEQ, or for at least 2 hours after you take it. If you take food with TRIUMEQ, then you can take calcium and iron supplements at the same time as TRIUMEQ.
- etravirine, efavirenz, fosamprenavir/ritonavir, nevirapine or tipranavir/ritonavir to treat HIV infection
- rifampin, to treat tuberculosis (TB) and other bacterial infections
- phenytoin and phenobarbital, to treat epilepsy
- oxcarbazepine and carbamazepine, to treat epilepsy and bipolar disorder

- St. John's wort, (*Hypericum perforatum*), a herbal remedy to treat depression
- retinoids
- trimethoprim sulphamethoxazole (co-trimoxazole, an antibiotic used to treat *Pneumocystis jiroveci* pneumonia (often referred to as PCP) or toxoplasmosis)
- sorbitol-containing medicines (usually liquids) used regularly
- medicines that already contain abacavir, lamivudine or emtricitabine such as 3TC, HEPTOVIR, COMBIVIR, ZIAGEN, TRIZIVIR, KIVEXA, TRUVADA, COMPLERA, ATRIPLA, EMTRIVA and STRIBILD

If you are taking methadone, your doctor may need to adjust your methadone dose, as abacavir increases the rate at which methadone leaves your body. This is unlikely to affect most methadone users.

PROPER USE OF THIS MEDICATION

Always take TRIUMEQ exactly as your doctor has told you to. Check with your doctor or pharmacist if you're not sure. Do not change your dose or stop taking TRIUMEQ without talking with your doctor.

Usual dose:

Take TRIUMEQ exactly as your doctor has advised you, and try not to miss any doses. The usual dose in adults and children who weigh at least 40 kg (12 years and older) is one tablet once a day. Your doctor will determine if the child is able to swallow the tablet. Swallow the tablet whole with water or some liquid. TRIUMEQ can be taken with or without food.

TRIUMEQ is a set (fixed) dose combination of dolutegravir, abacavir and lamivudine, and therefore cannot be dose reduced. Therefore, TRIUMEQ cannot be used if you have certain kidney or liver problems because you cannot change the dose. If you are unsure about how to take it, ask your doctor or pharmacist.

Overdose:

If you take too many tablets of TRIUMEQ, contact your doctor or pharmacist for advice. If possible, show them the TRIUMEQ pack.

In case of drug overdose, contact a health care practitioner, hospital emergency department or regional Poison Control Centre immediately, even if there are no symptoms.

Missed Dose:

If you miss a dose, take it as soon as you remember, but if your next dose is due within 4 hours, skip the dose you missed and take the next one at the usual time. Then continue your treatment as before.

If you stopped taking TRIUMEQ:

If you stop taking TRIUMEQ because of side effects or illness, you must contact your doctor before restarting to make sure that symptoms of a hypersensitivity reaction have not been missed. In some cases your doctor will ask you to restart TRIUMEQ under direct medical supervision or in a place where you will be able to get ready access to medical care if needed.

SIDE EFFECTS AND WHAT TO DO ABOUT THEM

Like all medicines, TRIUMEQ can have side effects. When treating HIV infection, it is not always possible to tell whether some of the undesirable effects that occur are caused by TRIUMEQ, by other medicines you are taking at the same time or by the HIV infection. For this reason it is very important that you inform your doctor about any changes in your health.

A hypersensitivity reaction (serious allergic reaction) has been reported in patients who have been treated with abacavir containing products. This is described in the Warnings and Precautions section on Hypersensitivity Reaction in the beginning of this leaflet. It is important that you read and understand the information about this serious reaction.

TRIUMEQ contains dolutegravir, abacavir and lamivudine. The most common side effects for this combination are nausea, vomiting, diarrhea, abdominal pain and bloating (abdominal distension), headache, high temperature (fever), lethargy (unusual lack of energy), fatigue, trouble sleeping, depression/depressed mood (feelings of deep sadness and unworthiness), anxiety, loss of appetite, hair loss, joint and muscle pain, abacavir hypersensitivity (serious allergic reaction) and skin rash (without any other illness). **If these symptoms persist or become bothersome, contact your doctor.**

Other side effects include, stomach discomfort, dizziness, abnormal dreams, suicidal thoughts and behaviours (mainly in patients who have had depression or mental health problems before), weight gain and intestinal gas (flatulence). Very rare side effects include serious skin reactions and severe anemia.

Side effects that may show up in blood tests include an

increase in bilirubin (a substance produced by the liver), an increase in the level of enzymes produced in the muscles (creatine phosphokinase) and/or an increase in kidney function test results (creatinine). Blood tests will also be used to check for liver problems.

Changes to your immune system (Immune Reconstitution Inflammatory Syndrome) can happen when you start taking HIV-1 medicines. Your immune system may get stronger and begin to fight infections that have been hidden in your body for a long time.

Autoimmune disorders (when the immune system attacks healthy body tissue), may also occur after you start taking medicines for HIV infection. Examples of this include: Grave's disease (which affects the thyroid gland), Guillain-Barré syndrome (which affects the nervous system), polymyositis (which affects the muscles), or autoimmune hepatitis (which affects the liver). Autoimmune disorders may occur many months after the start of treatment. Look for any other symptoms such as:

- high temperature (fever), redness, rash or swelling
- fatigue
- joint or muscle pain
- numbness, tingling, or weakness beginning in the hands and feet and moving up towards the trunk of the body
- palpitations (chest pain) or rapid heart rate
- yellowing of the skin or eyes
- anxiety and irritability accompanied by tremor of your hands or fingers
- muscle weakness in your hips, thighs, shoulders, upper arms and neck.

If you notice these or any symptoms of inflammation or infection, tell your doctor immediately.

Inflammation of the pancreas (pancreatitis) has been observed in patients treated with abacavir and lamivudine, although it was not clear whether this was due to the medicine or the HIV infection itself (See Side Serious Side Effects table). If your doctor detects clinical signs, symptoms or lab tests suggestive of pancreatitis, they will stop treatment with TRIUMEQ immediately.

Always tell your doctor or pharmacist if any of the side effects mentioned becomes severe or troublesome, or if you notice any other side effects not listed in this leaflet.

SERIOUS SIDE EFFECTS, HOW OFTEN THEY HAPPEN AND WHAT TO DO ABOUT THEM

Symptom / effect	Talk with your doctor or pharmacist immediately		Stop taking drug and call your doctor or pharmacist
	Only if severe	In all cases	
<p>Common</p> <p><u>Hypersensitivity to abacavir:</u> Serious allergic reaction and 2 or more of the following symptoms: fever, skin rash, nausea, vomiting, diarrhea, abdominal pain, severe tiredness, achiness, general ill-feeling, sore throat, shortness of breath.</p>		✓	
<p>Uncommon</p> <p><u>Hypersensitivity to dolutegravir:</u> Skin rash, fever, lack of energy, swelling of the mouth or face causing difficulty in breathing, muscle or joint aches.</p>		✓	
<p><u>Liver problems (Hepatitis):</u> High liver blood test results, nausea/vomiting loss of appetite, pain, aching or tenderness on the right side below the ribs. If hepatitis is severe, the following may occur: yellowing of the skin or whites of the eyes, dark or tea coloured urine, pale coloured stools/ bowel movements.</p>		✓	

Symptom / effect	Talk with your doctor or pharmacist immediately		Stop taking drug and call your doctor or pharmacist
	Only if severe	In all cases	
<p><u>Blood problems:</u> Anemia (lowered red blood cell count – resulting in fatigue, breathlessness), low white blood cell count (neutropenia – increasing chance of infection), reduced platelets (blood cells important for blood clotting – could increase chance of bruising) and increases in enzymes produced by the muscles or kidneys.</p>		✓	
<p>Rare</p> <p><u>Liver failure:</u> Extremely high liver blood test results, nausea/vomiting, loss of appetite, pain, aching or tenderness on the right side below the ribs, yellowing of the skin or whites of the eyes, dark or tea coloured urine, pale coloured stools/ bowel movements.</p>		✓	
<p><u>Pancreatitis (inflammation of the pancreas):</u> Nausea, vomiting and abdominal pain.</p>		✓	
<p><u>Lactic acidosis (high level of acid in the blood):</u> Weight loss, fatigue, malaise, abdominal pain, shortness of breath, severe hepatomegaly (swollen and enlarged liver) with symptoms of liver problems such as nausea, vomiting, abdominal pain, weakness and diarrhea.</p>		✓	

This is not a complete list of side effects. For any unexpected effects while taking TRIUMEQ, contact your doctor or pharmacist.

HOW TO STORE IT

Store TRIUMEQ in the original package (HDPE bottle) in order to protect from moisture. Keep the bottle tightly closed. Do not remove the silica gel dessicant. Store up to 30°C.

Keep out of reach and sight of children.

Reporting Side Effects

You can report any suspected side effects associated with the use of health products to Health Canada by:

- Visiting the Web page on Adverse Reaction Reporting (<https://www.canada.ca/en/health-canada/services/drugs-health-products/medeffect-canada/adverse-reaction-reporting.html>) for information on how to report online, by mail or by fax; or
- Calling toll-free at 1-866-234-2345.

NOTE: Contact your health professional if you need information about how to manage your side effects. The Canada Vigilance Program does not provide medical advice.

MORE INFORMATION

This document plus the full product monograph, prepared for health professionals can be found at:

www.viivhealthcare.com

or by contacting the sponsor, ViiV Healthcare ULC at:

245, boulevard Armand-Frappier
Laval, Quebec
H7V 4A7
1-877-393-8448

This leaflet was prepared by ViiV Healthcare ULC.

Last revised: January 31, 2020

© 2020 ViiV Healthcare group of companies or its licensor

Trademarks are owned by or licensed to the ViiV Healthcare group of companies

Trademarks are owned by or licensed to the GSK group of companies

TRUVADA, COMPLERA and STRIBILD are registered trademarks of Gilead Sciences Ireland UC.

ATRIPLA is a registered trademark of Bristol-Myers Squibb and Gilead Sciences, LLC.

EMTRIVA is a registered trademark of Gilead Sciences, Inc.

INFORMATION FOR PRESCRIBERS

A copy of the warning card included with the TRIUMEQ carton is shown below.

Warning Card	
TRIUMEQ (dolutegravir, abacavir, and lamivudine) tablets	
<p>Patients taking abacavir-containing products, such as TRIUMEQ, may develop a hypersensitivity reaction (a serious allergic reaction) which can be life threatening if you continue to take TRIUMEQ. If you notice two or more of the following sets of symptoms while taking TRIUMEQ, contact your doctor immediately to find out if you should stop taking TRIUMEQ:</p>	
	SYMPTOM(S)
Group 1	Fever
Group 2	Rash
Group 3	Nausea, vomiting, diarrhea, or abdominal (stomach area) pain
Group 4	Generally ill feeling, extreme tiredness or achiness
Group 5	Shortness of breath, cough or sore throat
<p>If you have already had this reaction to an abacavir-containing product, such as KIVEXA, TRIZIVIR or ZIAGEN, never take any medicine containing abacavir again, unless instructed by a physician to do so and under direct medical supervision. If you do take any medicine containing abacavir again, within hours you may experience a life threatening lowering of your blood pressure or death.</p>	
<p>Carry this card with you at all times.</p>	
<p>You should return all of your unused TRIUMEQ to your doctor or pharmacist for proper disposal.</p>	
<p>ViiV Healthcare ULC Laval, Quebec H7V 4A7</p>	

HIGHLIGHTS OF PRESCRIBING INFORMATION

These highlights do not include all the information needed to use TRIUMEQ safely and effectively. See full prescribing information for TRIUMEQ.

TRIUMEQ (abacavir, dolutegravir, and lamivudine) tablets, for oral use
Initial U.S. Approval: 2014

WARNING: HYPERSENSITIVITY REACTIONS, LACTIC ACIDOSIS AND SEVERE HEPATOMEGALY, AND EXACERBATIONS OF HEPATITIS B

See full prescribing information for complete boxed warning.

- Serious and sometimes fatal hypersensitivity reactions have been associated with abacavir-containing products. (5.1)
- Hypersensitivity to abacavir is a multi-organ clinical syndrome. (5.1)
- Patients who carry the HLA-B*5701 allele are at high risk for experiencing a hypersensitivity reaction to abacavir. (5.1)
- Discontinue TRIUMEQ as soon as a hypersensitivity reaction is suspected. Regardless of HLA-B*5701 status, permanently discontinue TRIUMEQ if hypersensitivity cannot be ruled out, even when other diagnoses are possible. (5.1)
- Following a hypersensitivity reaction to abacavir, NEVER restart TRIUMEQ or any other abacavir-containing product. (5.1)
- Lactic acidosis and severe hepatomegaly with steatosis, including fatal cases, have been reported with the use of nucleoside analogues. (5.2)
- Severe acute exacerbations of hepatitis B have been reported in patients who are co-infected with hepatitis B virus (HBV) and human immunodeficiency virus (HIV-1) and have discontinued lamivudine, a component of TRIUMEQ. Monitor hepatic function closely in these patients and, if appropriate, initiate anti-hepatitis B treatment. (5.3)

INDICATIONS AND USAGE

TRIUMEQ, a combination of dolutegravir (integrase strand transfer inhibitor [INSTI]), abacavir, and lamivudine (both nucleoside analogue reverse transcriptase inhibitors) is indicated for the treatment of HIV-1 infection. (1)

Limitations of Use:

- TRIUMEQ alone is not recommended for use in patients with current or past history of resistance to any components of TRIUMEQ. (12.4)
- TRIUMEQ alone is not recommended in patients with resistance-associated integrase substitutions or clinically suspected integrase strand transfer inhibitor resistance because the dose of dolutegravir in TRIUMEQ is insufficient in these subpopulations. See the dolutegravir prescribing information. (1)

DOSAGE AND ADMINISTRATION

- Before initiating TRIUMEQ, screen for the HLA-B*5701 allele because TRIUMEQ contains abacavir. (2.1)
- Adults: One tablet daily. May be taken with or without food. (2.2)
- Dosing with certain concomitant medications: If efavirenz, fosamprenavir/ritonavir, tipranavir/ritonavir, or rifampin are coadministered, then the recommended dolutegravir dosage regimen is 50 mg twice daily. An additional 50-mg dose of dolutegravir, separated by 12 hours from TRIUMEQ, should be taken. (2.3)

FULL PRESCRIBING INFORMATION: CONTENTS*

WARNING: HYPERSENSITIVITY REACTIONS, LACTIC ACIDOSIS AND SEVERE HEPATOMEGALY, AND EXACERBATIONS OF HEPATITIS B

1 INDICATIONS AND USAGE

2 DOSAGE AND ADMINISTRATION

2.1 Screening for HLA-B*5701 Allele Prior to Starting TRIUMEQ

2.2 Recommended Dosage

2.3 Dosage Recommendation with Certain Concomitant Medications

3 DOSAGE FORMS AND STRENGTHS

4 CONTRAINDICATIONS

5 WARNINGS AND PRECAUTIONS

5.1 Hypersensitivity Reaction

5.2 Lactic Acidosis and Severe Hepatomegaly with Steatosis

5.3 Patients with Hepatitis B or C Virus Co-infection

5.4 Use with Interferon- and Ribavirin-based Regimens

DOSAGE FORMS AND STRENGTHS

Tablets: 600 mg of abacavir, 50 mg of dolutegravir, and 300 mg of lamivudine. (3)

CONTRAINDICATIONS

- Presence of HLA-B*5701 allele. (4)
- Previous hypersensitivity reaction to abacavir, dolutegravir, or lamivudine. (4)
- Coadministration with dofetilide. (4)
- Moderate or severe hepatic impairment. (4, 8.7)

WARNINGS AND PRECAUTIONS

- Patients with underlying hepatitis B or C may be at increased risk for worsening or development of transaminase elevations with use of TRIUMEQ. Appropriate laboratory testing prior to initiating therapy and monitoring for hepatotoxicity during therapy with TRIUMEQ is recommended in patients with underlying hepatic disease such as hepatitis B or C. (5.3)
- Hepatic decompensation, some fatal, has occurred in HIV-1/HCV co-infected patients receiving combination antiretroviral therapy and interferon alfa with or without ribavirin. Discontinue TRIUMEQ as medically appropriate and consider dose reduction or discontinuation of interferon alfa, ribavirin, or both. (5.4)
- Immune reconstitution syndrome and redistribution/accumulation of body fat have been reported in patients treated with combination antiretroviral therapy. (5.5, 5.6)
- Administration of TRIUMEQ is not recommended in patients receiving other products containing abacavir or lamivudine. (5.8)

ADVERSE REACTIONS

The most commonly reported adverse reactions of at least moderate intensity and incidence at least 2% (in those receiving TRIUMEQ) were insomnia, headache, and fatigue. (6.1)

To report SUSPECTED ADVERSE REACTIONS, contact ViiV Healthcare at 1-877-844-8872 or FDA at 1-800-FDA-1088 or www.fda.gov/medwatch.

DRUG INTERACTIONS

Coadministration of TRIUMEQ with other drugs can alter the concentration of other drugs and other drugs may alter the concentrations of TRIUMEQ. The potential drug-drug interactions must be considered prior to and during therapy. (4, 7, 12.3)

USE IN SPECIFIC POPULATIONS

- Pregnancy: TRIUMEQ should be used during pregnancy only if the potential benefit justifies the potential risk. (8.1)
- Nursing mothers: Breastfeeding is not recommended due to the potential for HIV transmission. (8.3)
- TRIUMEQ is not recommended in patients with creatinine clearance less than 50 mL per min. (8.6)
- If a dose reduction of abacavir, a component of TRIUMEQ, is required for patients with mild hepatic impairment, then the individual components should be used. (8.7)

See 17 for PATIENT COUNSELING INFORMATION and Medication Guide.

Revised: 08/2014

5.5 Immune Reconstitution Syndrome

5.6 Fat Redistribution

5.7 Myocardial Infarction

5.8 Related Products that are Not Recommended

6 ADVERSE REACTIONS

6.1 Clinical Trials Experience

6.2 Postmarketing Experience

7 DRUG INTERACTIONS

7.1 Effect of Dolutegravir on the Pharmacokinetics of Other Agents

7.2 Effect of Other Agents on the Pharmacokinetics of Dolutegravir

7.3 Established and Other Potentially Significant Drug Interactions

8 USE IN SPECIFIC POPULATIONS

8.1 Pregnancy

8.3 Nursing Mothers

8.4 Pediatric Use

8.5 Geriatric Use

- 8.6 Patients with Impaired Renal Function
- 8.7 Patients with Impaired Hepatic Function
- 10 OVERDOSAGE**
- 11 DESCRIPTION**
- 12 CLINICAL PHARMACOLOGY**
 - 12.1 Mechanism of Action
 - 12.2 Pharmacodynamics
 - 12.3 Pharmacokinetics
 - 12.4 Microbiology

- 13 NONCLINICAL TOXICOLOGY**
 - 13.1 Carcinogenesis, Mutagenesis, Impairment of Fertility
 - 13.2 Animal Toxicology and/or Pharmacology
 - 14 CLINICAL STUDIES**
 - 14.1 Adult Subjects
 - 16 HOW SUPPLIED/STORAGE AND HANDLING**
 - 17 PATIENT COUNSELING INFORMATION**
- *Sections or subsections omitted from the full prescribing information are not listed.

FULL PRESCRIBING INFORMATION

WARNING: HYPERSENSITIVITY REACTIONS, LACTIC ACIDOSIS AND SEVERE HEPATOMEGALY, AND EXACERBATIONS OF HEPATITIS B

Hypersensitivity Reactions

Serious and sometimes fatal hypersensitivity reactions, with multiple organ involvement, have been associated with abacavir, a component of TRIUMEQ[®]. Patients who carry the HLA-B*5701 allele are at a higher risk of a hypersensitivity reaction to abacavir; although, hypersensitivity reactions have occurred in patients who do not carry the HLA-B*5701 allele [see *Warnings and Precautions (5.1)*].

All patients should be screened for the HLA-B*5701 allele prior to initiating therapy with TRIUMEQ or reinitiation of therapy with TRIUMEQ unless patients have had an HLA-B*5701 allele assessment. Discontinue TRIUMEQ if a hypersensitivity reaction is suspected. TRIUMEQ is contraindicated in patients who have the HLA-B*5701 allele or in patients with a prior hypersensitivity reaction to abacavir [see *Contraindications (4)*, *Warnings and Precautions (5.1)*]. Reintroduction of TRIUMEQ or any other abacavir-containing product can result in life-threatening or fatal hypersensitivity reactions, even in patients who have no history of hypersensitivity to abacavir therapy. Such reactions can occur within hours [see *Warnings and Precautions (5.1)*].

Lactic Acidosis and Severe Hepatomegaly

Lactic acidosis and severe hepatomegaly with steatosis, including fatal cases, have been reported with the use of nucleoside analogues alone or in combination, including abacavir, lamivudine, and other antiretrovirals. Discontinue TRIUMEQ if clinical or laboratory findings suggestive of lactic acidosis or pronounced hepatotoxicity occur [see *Warnings and Precautions (5.2)*].

Exacerbations of Hepatitis B

Severe acute exacerbations of hepatitis B have been reported in patients who are co-infected with hepatitis B virus (HBV) and human immunodeficiency virus (HIV-1) and have discontinued lamivudine, one component of TRIUMEQ. Hepatic function should be monitored closely with both clinical and laboratory follow-up for at least several months in patients who discontinue TRIUMEQ and are co-infected with HIV-1 and HBV. If appropriate, initiation of anti-hepatitis B therapy may be warranted [see *Warnings and Precautions (5.3)*].

1 INDICATIONS AND USAGE

TRIUMEQ is indicated for the treatment of human immunodeficiency virus type 1 (HIV-1) infection.

Limitations of Use:

- TRIUMEQ alone is not recommended for use in patients with current or past history of resistance to any components of TRIUMEQ [see *Microbiology (12.4)*].
- TRIUMEQ alone is not recommended in patients with resistance-associated integrase substitutions or clinically suspected integrase strand transfer inhibitor resistance because the dose of dolutegravir in TRIUMEQ is insufficient in these subpopulations. See full prescribing information for dolutegravir.

2 DOSAGE AND ADMINISTRATION

2.1 Screening for HLA-B*5701 Allele Prior to Starting TRIUMEQ

Screen for the HLA-B*5701 allele prior to initiating therapy with TRIUMEQ [see *Boxed Warning, Warnings and Precautions (5.1)*].

2.2 Recommended Dosage

TRIUMEQ is a fixed-dose combination product containing 600 mg of abacavir, 50 mg of dolutegravir, and 300 mg of lamivudine. The recommended dosage regimen of TRIUMEQ in adults is one tablet once daily orally with or without food.

2.3 Dosage Recommendation with Certain Concomitant Medications

The dolutegravir dose (50 mg) in TRIUMEQ is insufficient when coadministered with medications listed in Table 1 that may decrease dolutegravir concentrations; the following dolutegravir dosage regimen is recommended.

Table 1. Dosing Recommendations for TRIUMEQ with Coadministered Medications

Coadministered Drug	Dosing Recommendation
Efavirenz, fosamprenavir/ritonavir, tipranavir/ritonavir, or rifampin	The recommended dolutegravir dosage regimen is 50 mg twice daily. An additional dolutegravir 50-mg tablet, separated by 12 hours from TRIUMEQ, should be taken.

3 DOSAGE FORMS AND STRENGTHS

TRIUMEQ tablets are purple, biconvex, oval, and debossed with “572 Tri” on one side. Each film-coated tablet contains abacavir sulfate equivalent to 600 mg of abacavir, dolutegravir sodium equivalent to 50 mg of dolutegravir, and 300 mg of lamivudine [see *Description (11)*].

4 CONTRAINDICATIONS

TRIUMEQ is contraindicated in patients:

- who have the HLA-B*5701 allele [see *Warnings and Precautions (5.1)*].
- with previous hypersensitivity reaction to abacavir. Before starting TRIUMEQ, review medical history for prior exposure to any abacavir-containing product. NEVER restart

TRIUMEQ or any other abacavir-containing product following a hypersensitivity reaction to abacavir, regardless of HLA-B*5701 status [see *Warnings and Precautions (5.1)*].

- with previous hypersensitivity reaction to dolutegravir [see *Warnings and Precautions (5.1)*] or lamivudine.
- receiving dofetilide, due to the potential for increased dofetilide plasma concentrations and the risk for serious and/or life-threatening events with concomitant use of dolutegravir [see *Drug Interactions (7)*].
- with moderate or severe hepatic impairment [see *Use in Specific Populations (8.7)*].

5 WARNINGS AND PRECAUTIONS

5.1 Hypersensitivity Reaction

Hypersensitivity reactions have been reported with the use of abacavir or dolutegravir, components of TRIUMEQ.

Abacavir: Serious and sometimes fatal hypersensitivity reactions have been associated with abacavir-containing regimens. See full prescribing information for ZIAGEN[®] (abacavir). Patients who carry the HLA-B*5701 allele are at high risk for experiencing a hypersensitivity reaction to abacavir. All patients should be screened for the HLA-B*5701 allele prior to initiating therapy with abacavir or reinitiation of abacavir therapy unless HLA-B*5701 information is available. Do not treat HLA-B*5701-positive patients with an abacavir-containing regimen [see *Contraindications (4)*].

HLA-B*5701-negative patients may develop a hypersensitivity reaction to abacavir; however, this occurs significantly less frequently than in HLA-B*5701-positive patients. Regardless of HLA-B*5701 status, permanently discontinue TRIUMEQ if hypersensitivity cannot be ruled out, even when other diagnoses are possible.

Symptoms indicating a multi-organ clinical syndrome usually appear within the first 6 weeks of treatment with abacavir (median time to onset was 9 days), although the reaction may occur at any time during therapy. The reaction is typically characterized by the presentation of key signs or symptoms in 2 or more of the following groups: (1) fever; (2) rash; (3) gastrointestinal (including nausea, vomiting, diarrhea, or abdominal pain); (4) constitutional (including generalized malaise, fatigue, or achiness); (5) respiratory (including dyspnea, cough, or pharyngitis).

Other signs and symptoms of hypersensitivity include lethargy, headache, myolysis, edema, abnormal chest x-ray findings (predominantly infiltrates, which can be localized), arthralgia, and paresthesia. Anaphylaxis, liver failure, renal failure, hypotension, adult respiratory distress syndrome, respiratory failure, and death have occurred in association with hypersensitivity reactions. Physical findings associated with hypersensitivity to abacavir in some subjects include lymphadenopathy, mucous membrane lesions (conjunctivitis and mouth ulcerations), and rash. The rash usually appears maculopapular or urticarial, but may be variable in appearance. There have been reports of erythema multiforme. Hypersensitivity reactions have occurred without rash.

Laboratory abnormalities associated with hypersensitivity to abacavir in some subjects include elevated liver function tests, elevated creatine phosphokinase, elevated creatinine, and lymphopenia.

Clinical Management of Abacavir Hypersensitivity: Discontinue TRIUMEQ as soon as a hypersensitivity reaction is suspected. To minimize the risk of a life-threatening hypersensitivity reaction, permanently discontinue TRIUMEQ if hypersensitivity cannot be ruled out, even when other diagnoses are possible (e.g., acute onset respiratory diseases such as pneumonia, bronchitis, pharyngitis, or influenza; gastroenteritis; or reactions to other medications).

Following a hypersensitivity reaction to abacavir, NEVER restart TRIUMEQ or any other abacavir-containing product because more severe symptoms can occur within hours and may include life-threatening hypotension and death.

When therapy with TRIUMEQ has been discontinued for reasons other than symptoms of a hypersensitivity reaction, and if reinitiation of TRIUMEQ or any other abacavir-containing product is under consideration, carefully evaluate the reason for discontinuation of TRIUMEQ to ensure that the patient did not have symptoms of a hypersensitivity reaction.

If hypersensitivity cannot be ruled out, DO NOT reintroduce TRIUMEQ or any other abacavir-containing product.

If symptoms consistent with abacavir hypersensitivity are not identified, reintroduction can be undertaken with continued monitoring for symptoms of a hypersensitivity reaction. Make patients aware that a hypersensitivity reaction can occur with reintroduction of TRIUMEQ or any other abacavir-containing product and that reintroduction of TRIUMEQ or introduction of any other abacavir-containing product needs to be undertaken only if medical care can be readily accessed by the patient or others.

In any patient treated with abacavir, the clinical diagnosis of hypersensitivity reaction must remain the basis of clinical decision-making. Even in the absence of the HLA-B*5701 allele, it is important to permanently discontinue abacavir and not rechallenge with abacavir if a hypersensitivity reaction cannot be ruled out on clinical grounds, due to the potential for a severe or even fatal reaction.

Dolutegravir: Hypersensitivity reactions have been reported and were characterized by rash, constitutional findings, and sometimes organ dysfunction, including liver injury. The events were reported in less than 1% of subjects receiving TIVICAY® in Phase 3 clinical trials. Discontinue TRIUMEQ and other suspect agents immediately if signs or symptoms of hypersensitivity reactions develop (including, but not limited to, severe rash or rash accompanied by fever, general malaise, fatigue, muscle or joint aches, blisters or peeling of the skin, oral blisters or lesions, conjunctivitis, facial edema, hepatitis, eosinophilia, angioedema, difficulty breathing). Clinical status, including liver aminotransferases, should be monitored and appropriate therapy initiated. Delay in stopping treatment with TRIUMEQ or other suspect agents after the onset of hypersensitivity may result in a life-threatening reaction.

Clinically, it is not possible to determine whether a hypersensitivity reaction with TRIUMEQ would be caused by abacavir or dolutegravir. Therefore, never restart TRIUMEQ or any other abacavir- or dolutegravir-containing product in patients who have stopped therapy with TRIUMEQ due to a hypersensitivity reaction.

5.2 Lactic Acidosis and Severe Hepatomegaly with Steatosis

Lactic acidosis and severe hepatomegaly with steatosis, including fatal cases, have been reported with the use of nucleoside analogues and other antiretrovirals. See full prescribing information for ZIAGEN (abacavir) and EPIVIR[®] (lamivudine). Treatment with TRIUMEQ should be suspended in any patient who develops clinical or laboratory findings suggestive of lactic acidosis or pronounced hepatotoxicity (which may include hepatomegaly and steatosis even in the absence of marked transaminase elevations).

5.3 Patients with Hepatitis B or C Virus Co-infection

Effects on Serum Liver Biochemistries: Patients with underlying hepatitis B or C may be at increased risk for worsening or development of transaminase elevations with use of TRIUMEQ [see *Adverse Reactions (6.1)*]. See full prescribing information for TIVICAY (dolutegravir). In some cases the elevations in transaminases were consistent with immune reconstitution syndrome or hepatitis B reactivation particularly in the setting where anti-hepatitis therapy was withdrawn. Appropriate laboratory testing prior to initiating therapy and monitoring for hepatotoxicity during therapy with TRIUMEQ are recommended in patients with underlying hepatic disease such as hepatitis B or C.

Posttreatment Exacerbations of Hepatitis: Clinical and laboratory evidence of exacerbations of hepatitis have occurred after discontinuation of lamivudine. See full prescribing information for EPIVIR (lamivudine). Patients should be closely monitored with both clinical and laboratory follow-up for at least several months after stopping treatment.

Emergence of Lamivudine-Resistant HBV: Safety and efficacy of lamivudine have not been established for treatment of chronic hepatitis B in subjects dually infected with HIV-1 and HBV. Emergence of hepatitis B virus variants associated with resistance to lamivudine has also been reported in HIV-1-infected subjects who have received lamivudine-containing antiretroviral regimens in the presence of concurrent infection with hepatitis B virus. See full prescribing information for EPIVIR (lamivudine).

5.4 Use with Interferon- and Ribavirin-based Regimens

Patients receiving interferon alfa with or without ribavirin and TRIUMEQ should be closely monitored for treatment-associated toxicities, especially hepatic decompensation. See full prescribing information for EPIVIR (lamivudine). Discontinuation of TRIUMEQ should be considered as medically appropriate. Dose reduction or discontinuation of interferon alfa, ribavirin, or both should also be considered if worsening clinical toxicities are observed, including hepatic decompensation (e.g., Child-Pugh greater than 6) (see full prescribing information for interferon and ribavirin).

5.5 Immune Reconstitution Syndrome

Immune reconstitution syndrome has been reported in patients treated with combination antiretroviral therapy, including TRIUMEQ. During the initial phase of combination antiretroviral treatment, patients whose immune systems respond may develop an inflammatory response to indolent or residual opportunistic infections (such as *Mycobacterium avium* infection, cytomegalovirus, *Pneumocystis jirovecii* pneumonia [PCP], or tuberculosis), which may necessitate further evaluation and treatment.

Autoimmune disorders (such as Graves' disease, polymyositis, and Guillain-Barré syndrome) have also been reported to occur in the setting of immune reconstitution; however, the time to onset is more variable, and can occur many months after initiation of treatment.

5.6 Fat Redistribution

Redistribution/accumulation of body fat including central obesity, dorsocervical fat enlargement (buffalo hump), peripheral wasting, facial wasting, breast enlargement, and “cushingoid appearance” have been observed in patients receiving antiretroviral therapy. The mechanism and long-term consequences of these events are currently unknown. A causal relationship has not been established.

5.7 Myocardial Infarction

In a published prospective, observational, epidemiological trial designed to investigate the rate of myocardial infarction (MI) in patients on combination antiretroviral therapy, the use of abacavir within the previous 6 months was correlated with an increased risk of MI. In a sponsor-conducted pooled analysis of clinical trials, no excess risk of MI was observed in abacavir-treated subjects as compared with control subjects. In totality, the available data from the observational cohort and from clinical trials are inconclusive.

As a precaution, the underlying risk of coronary heart disease should be considered when prescribing antiretroviral therapies, including abacavir, and action taken to minimize all modifiable risk factors (e.g., hypertension, hyperlipidemia, diabetes mellitus, smoking).

5.8 Related Products that are Not Recommended

TRIUMEQ contains fixed doses of an INSTI (dolutegravir) and 2 nucleoside analogue reverse transcriptase inhibitors (abacavir and lamivudine); concomitant administration of TRIUMEQ with other products containing abacavir or lamivudine is not recommended.

6 ADVERSE REACTIONS

The following adverse reactions are discussed in other sections of the labeling:

- Serious and sometimes fatal hypersensitivity reaction [*see Boxed Warning, Warnings and Precautions (5.1)*].
- Lactic acidosis and severe hepatomegaly [*see Boxed Warning, Warnings and Precautions (5.2)*].
- Effects on serum liver biochemistries in patients with hepatitis B or C co-infection [*see Warnings and Precautions (5.3)*].
- Exacerbations of hepatitis B [*see Boxed Warning, Warnings and Precautions (5.3)*].

- Hepatic decompensation in patients co-infected with HIV-1 and Hepatitis C [see Warnings and Precautions (5.4)].
- Immune reconstitution syndrome [see Warnings and Precautions (5.5)].
- Fat redistribution [see Warnings and Precautions (5.6)].
- Myocardial infarction [see Warnings and Precautions (5.7)].

6.1 Clinical Trials Experience

Because clinical trials are conducted under widely varying conditions, adverse reaction rates observed in the clinical trials of a drug cannot be directly compared with rates in the clinical trials of another drug and may not reflect the rates observed in clinical practice.

Treatment-Emergent Adverse Drug Reactions (ADRs): The safety assessment of TRIUMEQ is primarily based on the analyses of data from a randomized, international, multicenter, double-blind, active-controlled trial, SINGLE (ING114467) and supported by data in treatment-experienced, INSTI-naïve subjects from SAILING (ING111762) and by data from other treatment-naïve trials. See full prescribing information for TIVICAY.

Treatment-Naïve Subjects: In SINGLE, 833 adult subjects were randomized and received at least one dose of either dolutegravir (TIVICAY) 50 mg with fixed-dose abacavir sulfate and lamivudine (EPZICOM[®]) once daily (n = 414) or fixed-dose efavirenz/emtricitabine/tenofovir (ATRIPLA[®]) once daily (n = 419). Through 96 weeks, the rate of adverse events leading to discontinuation was 3% in subjects receiving TIVICAY + EPZICOM and 12% in subjects receiving ATRIPLA once daily.

Treatment-emergent ADRs of moderate to severe intensity observed in at least 2% of subjects in either treatment arm of SINGLE are provided in Table 2.

Table 2. Treatment-Emergent Adverse Drug Reactions of at Least Moderate Intensity (Grades 2 to 4) and at Least 2% Frequency in Treatment-naïve Subjects in SINGLE (Week 96 Analysis)

Adverse Reaction	TIVICAY + EPZICOM Once Daily (N = 414)	ATRIPLA Once Daily (N = 419)
Psychiatric		
Insomnia	3%	2%
Depression	1%	2%
Abnormal dreams	<1%	2%
Nervous System		
Dizziness	<1%	5%
Headache	2%	2%
Gastrointestinal		
Nausea	<1%	3%
Diarrhea	<1%	2%

Adverse Reaction	TIVICAY + EPZICOM Once Daily (N = 414)	ATRIPLA Once Daily (N = 419)
General Disorders		
Fatigue	2%	2%
Skin and Subcutaneous Tissue		
Rash ^a	<1%	6%
Ear and Labyrinth		
Vertigo	0	2%

^a Includes pooled terms: rash, rash generalized, rash macular, rash maculo-papular, rash pruritic, and drug eruption.

Treatment-experienced Subjects: SAILING is an international, double-blind trial in INSTI-naïve, antiretroviral treatment-experienced adult subjects. Subjects were randomized and received either TIVICAY 50 mg once daily or raltegravir 400 mg twice daily with investigator-selected background regimen consisting of up to 2 agents, including at least one fully active agent. At 48 weeks, the rate of adverse events leading to discontinuation was consistent with that seen in the overall treatment-naïve patient population. See full prescribing information for TIVICAY.

The ADRs observed in the subset of subjects who received TIVICAY + EPZICOM were generally consistent with those seen in the overall treatment-naïve patient population.

Less Common Adverse Reactions Observed in Clinical Trials: The following adverse reactions occurred in less than 2% of treatment-naïve or treatment-experienced subjects in any one trial. These events have been included because of their seriousness and/or assessment of potential causal relationship.

Gastrointestinal Disorders: Abdominal pain, abdominal distention, abdominal discomfort, dyspepsia, flatulence, gastroesophageal reflux disease, upper abdominal pain, vomiting.

General Disorders: Fever, lethargy.

Hepatobiliary Disorders: Hepatitis.

Metabolism and Nutrition Disorders: Anorexia, hypertriglyceridemia.

Musculoskeletal Disorders: Arthralgia, myositis.

Nervous: Somnolence.

Psychiatric: Nightmare and sleep disorder.

Renal and Urinary Disorders: Renal impairment.

Skin and Subcutaneous Tissue Disorders: Pruritus.

Laboratory Abnormalities: *Treatment-Naïve Subjects:* Selected laboratory abnormalities (Grades 2 to 4) with a worsening grade from baseline and representing the worst-grade toxicity in at least 2% of subjects in SINGLE are presented in Table 3. The mean change from baseline observed for selected lipid values is presented in Table 4.

Table 3. Selected Laboratory Abnormalities (Grades 2 to 4) in Treatment-naïve Subjects in SINGLE (Week 96 Analysis)

Laboratory Abnormality	TIVICAY + EPZICOM Once Daily (N = 414)	ATRIPLA Once Daily (N = 419)
ALT		
Grade 2 (>2.5-5.0 x ULN)	2%	5%
Grade 3 to 4 (>5.0 x ULN)	<1%	<1%
AST		
Grade 2 (>2.5-5.0 x ULN)	3%	3%
Grade 3 to 4 (>5.0 x ULN)	<1%	3%
Creatine kinase		
Grade 2 (6.0-9.9 x ULN)	4%	1%
Grade 3 to 4 (\geq 10.0 x ULN)	5%	7%
Hyperglycemia		
Grade 2 (126-250 mg/dL)	7%	5%
Grade 3 (>250 mg/dL)	2%	<1%
Lipase		
Grade 2 (>1.5-3.0 x ULN)	9%	9%
Grade 3 to 4 (>3.0 ULN)	4%	3%
Total neutrophils		
Grade 2 ($0.75-0.99 \times 10^9$)	3%	5%
Grade 3 to 4 ($<0.75 \times 10^9$)	2%	3%

ULN = Upper limit of normal.

Table 4. Mean Change from Baseline in Fasted Lipid Values in Treatment-naïve Subjects in SINGLE (Week 96 Analysis)^a

Lipid	TIVICAY + EPZICOM Once Daily (N = 414)	ATRIPLA Once Daily (N = 419)
Cholesterol (mg/dL)	23.2	28.0
HDL cholesterol (mg/dL)	5.2	7.4
LDL cholesterol (mg/dL)	14.5	18.0
Triglycerides (mg/dL)	17.2	17.4

^a Subjects on lipid-lowering agents at baseline were excluded from these analyses (TIVICAY n = 30 and ATRIPLA n = 27). Fifty-five subjects initiated a lipid-lowering agent post-baseline; their last fasted on-treatment values (prior to starting the agent) were used regardless if they discontinued the agent (SINGLE: TIVICAY n = 25 and ATRIPLA: n = 30).

Treatment-experienced Subjects: Laboratory abnormalities observed in SAILING were generally similar compared with observations seen in the treatment-naïve trials.

Hepatitis C Virus Co-infection: In SINGLE, the pivotal Phase 3 trial, subjects with hepatitis C virus co-infection were permitted to enroll provided that baseline liver chemistry tests did not exceed 5 times the upper limit of normal; subjects with hepatitis B co-infection were excluded. Overall, the safety profile in subjects with hepatitis C virus co-infection was similar to that observed in subjects without hepatitis C co-infection, although the rates of AST and ALT abnormalities were higher in the subgroup with hepatitis C virus co-infection for both treatment groups. Grades 2 to 4 ALT abnormalities in hepatitis C co-infected compared with HIV mono-infected subjects receiving TRIUMEQ were observed in 15% and 2% (vs. 24% and 4% of subjects treated with ATRIPLA), respectively [*see Warnings and Precautions (5.3)*]. See also full prescribing information for TIVICAY.

Changes in Serum Creatinine: Dolutegravir has been shown to increase serum creatinine due to inhibition of tubular secretion of creatinine without affecting renal glomerular function [*see Clinical Pharmacology (12.2)*]. Increases in serum creatinine occurred within the first 4 weeks of treatment and remained stable through 24 to 96 weeks. In SINGLE, a mean change from baseline of 0.14 mg per dL (range: -0.32 mg per dL to 0.59 mg per dL) was observed after 96 weeks of treatment. Creatinine increases were similar in treatment-experienced subjects.

Abacavir Sulfate and Lamivudine: Laboratory abnormalities observed in clinical trials of ZIAGEN (in combination with other antiretroviral treatment) were anemia, neutropenia, liver function test abnormalities, and elevations of CPK, blood glucose, and triglycerides. Additional laboratory abnormalities observed in clinical trials of EPIVIR (in combination with other antiretroviral treatment) were thrombocytopenia and elevated levels of bilirubin, amylase, and lipase.

6.2 Postmarketing Experience

In addition to adverse reactions reported from clinical trials, the following adverse reactions have been identified during postmarketing use. Because these reactions are reported voluntarily from a population of uncertain size, it is not always possible to reliably estimate their frequency or establish a causal relationship to drug exposure.

Abacavir and/or Lamivudine:

Digestive: Stomatitis.

Gastrointestinal: Pancreatitis.

General: Weakness.

Blood and Lymphatic Systems: Aplastic anemia, anemia (including pure red cell aplasia and severe anemias progressing on therapy), lymphadenopathy, splenomegaly.

Hypersensitivity: Sensitization reactions (including anaphylaxis), urticaria.

Metabolism and Nutrition Disorders: Hyperlactemia.

Musculoskeletal: Muscle weakness, CPK elevation, rhabdomyolysis.

Nervous: Paresthesia, peripheral neuropathy, seizures.

Respiratory: Abnormal breath sounds/wheezing.

Skin: Alopecia, erythema multiforme. Suspected Stevens-Johnson syndrome (SJS) and toxic epidermal necrolysis (TEN) have been reported in patients receiving abacavir primarily in combination with medications known to be associated with SJS and TEN, respectively. Because of the overlap of clinical signs and symptoms between hypersensitivity to abacavir and SJS and TEN, and the possibility of multiple drug sensitivities in some patients, abacavir should be discontinued and not restarted in such cases.

7 DRUG INTERACTIONS

7.1 Effect of Dolutegravir on the Pharmacokinetics of Other Agents

In vitro, dolutegravir inhibited the renal organic cation transporters, OCT2 (IC₅₀ = 1.93 μM) and multidrug and toxin extrusion transporter (MATE) 1 (IC₅₀ = 6.34 μM). In vivo, dolutegravir inhibits tubular secretion of creatinine by inhibiting OCT2 and potentially MATE1. Dolutegravir may increase plasma concentrations of drugs eliminated via OCT2 or MATE1 (dofetilide and metformin) [see *Contraindications (4)*, *Drug Interactions (7.3)*].

In vitro, dolutegravir inhibited the basolateral renal transporters, organic anion transporter (OAT) 1 (IC₅₀ = 2.12 μM) and OAT3 (IC₅₀ = 1.97 μM). However, in vivo, dolutegravir did not alter the plasma concentrations of tenofovir or para-amino hippurate, substrates of OAT1 and OAT3.

In vitro, dolutegravir did not inhibit (IC₅₀ greater than 50 μM) the following: cytochrome P450 (CYP)1A2, CYP2A6, CYP2B6, CYP2C8, CYP2C9, CYP2C19, CYP2D6, CYP3A, UGT1A1, UGT2B7, P-glycoprotein (P-gp), breast cancer resistance protein (BCRP), bile salt export pump (BSEP), organic anion transporter polypeptide (OATP)1B1, OATP1B3, OCT1, or multidrug resistance protein (MRP)2, or MRP4. In vitro, dolutegravir did not induce CYP1A2, CYP2B6, CYP3A4. Based on these data and the results of drug interaction trials, dolutegravir is not expected to affect the pharmacokinetics of drugs that are substrates of these enzymes or transporters.

In drug interaction trials, dolutegravir did not have a clinically relevant effect on the pharmacokinetics of the following drugs: tenofovir, methadone, midazolam, rilpivirine, and oral contraceptives containing norgestimate and ethinyl estradiol. Using cross-study comparisons to historical pharmacokinetic data for each interacting drug, dolutegravir did not appear to affect the pharmacokinetics of the following drugs: atazanavir, darunavir, efavirenz, etravirine, fosamprenavir, lopinavir, ritonavir, and telaprevir.

7.2 Effect of Other Agents on the Pharmacokinetics of Dolutegravir

Dolutegravir is metabolized by UGT1A1 with some contribution from CYP3A. Dolutegravir is also a substrate of UGT1A3, UGT1A9, BCRP, and P-gp in vitro. Drugs that induce those enzymes and transporters may decrease dolutegravir plasma concentrations and reduce the therapeutic effect of dolutegravir.

Coadministration of dolutegravir and other drugs that inhibit these enzymes may increase dolutegravir plasma concentrations.

Etravirine significantly reduced plasma concentrations of dolutegravir, but the effect of etravirine was mitigated by coadministration of lopinavir/ritonavir or darunavir/ritonavir, and is expected to be mitigated by atazanavir/ritonavir (Table 5) [see *Drug Interactions (7.3), Clinical Pharmacology (12.3)*].

Darunavir/ritonavir, lopinavir/ritonavir, rilpivirine, tenofovir, boceprevir, telaprevir, prednisone, rifabutin, and omeprazole had no clinically significant effect on the pharmacokinetics of dolutegravir.

7.3 Established and Other Potentially Significant Drug Interactions

There were no drug-drug interaction trials conducted with the abacavir, dolutegravir, and lamivudine fixed-dose combination tablets.

Information regarding potential drug interactions with dolutegravir (Table 5) and abacavir are provided below. These recommendations are based on either drug interaction trials or predicted interactions due to the expected magnitude of interaction and potential for serious adverse events or loss of efficacy. [See *Clinical Pharmacology (12.3)*.]

Table 5. Established and Other Potentially Significant Drug Interactions for Dolutegravir: Alterations in Dose May Be Recommended Based on Drug Interaction Trials or Predicted Interactions

Concomitant Drug Class: Drug Name	Effect on Concentration	Clinical Comment
<i>HIV-1 Antiviral Agents</i>		
Non-nucleoside reverse transcriptase inhibitor: Etravirine ^a	↓Dolutegravir	Use of TRIUMEQ with etravirine without coadministration of atazanavir/ritonavir, darunavir/ritonavir, or lopinavir/ritonavir is not recommended.
Non-nucleoside reverse transcriptase inhibitor: Efavirenz ^a	↓Dolutegravir	Adjust dolutegravir dose to 50 mg twice daily. An additional 50-mg dose of dolutegravir should be taken, separated by 12 hours from TRIUMEQ.
Non-nucleoside reverse transcriptase inhibitor: Nevirapine	↓Dolutegravir	Avoid coadministration with TRIUMEQ because there are insufficient data to make dosing recommendations.
Protease inhibitor: Fosamprenavir/ritonavir ^a Tipranavir/ritonavir ^a	↓Dolutegravir	Adjust dolutegravir dose to 50 mg twice daily. An additional dolutegravir 50-mg dose should be taken, separated by 12 hours from TRIUMEQ.
<i>Other Agents</i>		
Oxcarbazepine	↓Dolutegravir	Avoid coadministration with TRIUMEQ

Concomitant Drug Class: Drug Name	Effect on Concentration	Clinical Comment
Phenytoin Phenobarbital Carbamazepine St. John's wort (<i>Hypericum perforatum</i>)		because there are insufficient data to make dosing recommendations.
Medications containing polyvalent cations (e.g., Mg or Al): Cation-containing antacids ^a or laxatives Sucralfate Buffered medications	↓Dolutegravir	Administer TRIUMEQ 2 hours before or 6 hours after taking medications containing polyvalent cations.
Oral calcium and iron supplements, including multivitamins containing calcium or iron^a	↓Dolutegravir	Administer TRIUMEQ 2 hours before or 6 hours after taking supplements containing calcium or iron. Alternatively, TRIUMEQ and supplements containing calcium or iron can be taken together with food.
Metformin	↑Metformin	Consider metformin dose reductions when coadministered with TRIUMEQ.
Rifampin ^a	↓Dolutegravir	Adjust dolutegravir dose to 50 mg twice daily. An additional 50-mg dose of dolutegravir should be taken, separated by 12 hours from TRIUMEQ.

^a See *Clinical Pharmacology (12.3) Table 9 for magnitude of interaction.*

Ethanol: Abacavir: Abacavir has no effect on the pharmacokinetic properties of ethanol. Ethanol decreases the elimination of abacavir causing an increase in overall exposure [*see Clinical Pharmacology (12.3)*].

Methadone: Abacavir: The addition of methadone has no clinically significant effect on the pharmacokinetic properties of abacavir. In a trial of 11 HIV-1–infected subjects receiving methadone-maintenance therapy with 600 mg of abacavir twice daily (twice the currently recommended dose), oral methadone clearance increased [*see Clinical Pharmacology (12.3)*]. This alteration will not result in a methadone dose modification in the majority of patients; however, an increased methadone dose may be required in a small number of patients. The addition of methadone had no clinically significant effect on the pharmacokinetic properties of abacavir.

8 USE IN SPECIFIC POPULATIONS

8.1 Pregnancy

Pregnancy Category C. There are no adequate and well-controlled trials in pregnant women. Reproduction studies with the components of TRIUMEQ have been performed in animals (see Dolutegravir, Abacavir, and Lamivudine sections below). Animal reproduction studies are not always predictive of human response. TRIUMEQ should be used during pregnancy only if the potential benefit outweighs the risks.

Antiretroviral Pregnancy Registry: To monitor maternal-fetal outcomes of pregnant women exposed to TRIUMEQ or other antiretroviral agents, an Antiretroviral Pregnancy Registry has been established. Physicians are encouraged to register patients by calling 1-800-258-4263.

Animal Data: *Dolutegravir:* Reproduction studies performed in rats and rabbits at doses up to 50 times the human dose of 50 mg once daily have revealed no evidence of impaired fertility or harm to the fetus due to dolutegravir.

Oral administration of dolutegravir to pregnant rats at doses up to 1,000 mg per kg daily, approximately 50 times the 50-mg once-daily human clinical exposure based on AUC, from days 6 to 17 of gestation did not elicit maternal toxicity, developmental toxicity, or teratogenicity.

Oral administration of dolutegravir to pregnant rabbits at doses up to 1,000 mg per kg daily, approximately 0.74 times the 50-mg once-daily human clinical exposure based on AUC, from days 6 to 18 of gestation did not elicit developmental toxicity or teratogenicity. In rabbits, maternal toxicity (decreased food consumption, scant/no feces/urine, suppressed body weight gain) was observed at 1,000 mg per kg.

Abacavir: Studies in pregnant rats showed that abacavir is transferred to the fetus through the placenta. Fetal malformations (increased incidences of fetal anasarca and skeletal malformations) and developmental toxicity (depressed fetal body weight and reduced crown-rump length) were observed in rats at a dose which produced 28 times the human exposure for a dose of 600 mg based on AUC. Embryonic and fetal toxicities (increased resorptions, decreased fetal body weights) and toxicities to the offspring (increased incidence of stillbirth and lower body weights) occurred at half of the above-mentioned dose in separate fertility studies conducted in rats. In the rabbit, no developmental toxicity and no increases in fetal malformations occurred at doses that produced 7 times the human exposure at the recommended dose based on AUC.

Lamivudine: Studies in pregnant rats showed that lamivudine is transferred to the fetus through the placenta. Reproduction studies with orally administered lamivudine have been performed in rats and rabbits at doses producing plasma levels up to approximately 32 times the human exposure for a dose of 300 mg. No evidence of teratogenicity due to lamivudine was observed. Evidence of early embryoletality was seen in the rabbit at exposure levels similar to those observed in humans, but there was no indication of this effect in the rat at plasma levels up to 32 times those in humans.

8.3 Nursing Mothers

The Centers for Disease Control and Prevention recommend that HIV-1-infected mothers in the United States not breastfeed their infants to avoid risking postnatal transmission of HIV-1 infection.

Because of both the potential for HIV-1 transmission and the potential for serious adverse reactions in nursing infants, instruct **mothers not to breastfeed**.

Dolutegravir: Studies in lactating rats and their offspring indicate that dolutegravir was present in rat milk. It is not known whether dolutegravir is excreted in human breast milk.

Abacavir: Abacavir is excreted in the milk of lactating rats.

Lamivudine: Lamivudine is excreted in human breast milk.

8.4 Pediatric Use

Safety and effectiveness of TRIUMEQ in pediatric patients have not been established [see *Clinical Pharmacology (12.3)*].

8.5 Geriatric Use

Clinical trials of abacavir, dolutegravir, or lamivudine did not include sufficient numbers of subjects aged 65 and over to determine whether they respond differently from younger subjects. In general, caution should be exercised in the administration of TRIUMEQ in elderly patient reflecting the greater frequency of decreased hepatic, renal, or cardiac function, and of concomitant disease or other drug therapy [see *Clinical Pharmacology (12.3)*].

8.6 Patients with Impaired Renal Function

TRIUMEQ is not recommended for patients with impaired renal function (creatinine clearance less than 50 mL per min) because TRIUMEQ is a fixed-dose combination and the dosage of the individual components cannot be adjusted. If a dose reduction of lamivudine, a component of TRIUMEQ, is required for patients with creatinine clearance less than 50 mL per min, then the individual components should be used [see *Clinical Pharmacology (12.3)*].

8.7 Patients with Impaired Hepatic Function

TRIUMEQ is a fixed-dose combination and the dosage of the individual components cannot be adjusted. If a dose reduction of abacavir, a component of TRIUMEQ, is required for patients with mild hepatic impairment (Child-Pugh Score A), then the individual components should be used [see *Clinical Pharmacology (12.3)*].

The safety, efficacy, and pharmacokinetic properties of abacavir have not been established in patients with moderate (Child-Pugh Score B) or severe (Child-Pugh Score C) hepatic impairment; therefore, TRIUMEQ is contraindicated in these patients.

10 OVERDOSAGE

There is no known specific treatment for overdose with TRIUMEQ. If overdose occurs, the patient should be monitored and standard supportive treatment applied as required.

Dolutegravir: As dolutegravir is highly bound to plasma proteins, it is unlikely that it will be significantly removed by dialysis.

Abacavir: It is not known whether abacavir can be removed by peritoneal dialysis or hemodialysis.

Lamivudine: Because a negligible amount of lamivudine was removed via (4-hour) hemodialysis, continuous ambulatory peritoneal dialysis, and automated peritoneal dialysis, it is not known if continuous hemodialysis would provide clinical benefit in a lamivudine overdose event. If overdose occurs, the patient should be monitored, and standard supportive treatment applied as required.

11 DESCRIPTION

TRIUMEQ: TRIUMEQ contains an INSTI (dolutegravir) and 2 nucleoside analogues (abacavir and lamivudine) with inhibitory activity against HIV.

Each film-coated tablet contains abacavir sulfate equivalent to 600 mg of abacavir, dolutegravir sodium equivalent to 50 mg of dolutegravir, and 300 mg of lamivudine. TRIUMEQ tablets are purple, biconvex, oval, debossed with “572 Tri” on one side and contain the inactive ingredients D-mannitol, magnesium stearate, microcrystalline cellulose, povidone, and sodium starch glycolate. The tablet film-coating (OPADRY® II Purple 85F90057) contains the inactive ingredients iron oxide black, iron oxide red, macrogol/PEG, polyvinyl alcohol–part hydrolyzed, talc, and titanium oxide.

Abacavir: The chemical name of abacavir sulfate is (1*S*,*cis*)-4-[2-amino-6-(cyclopropylamino)-9*H*-purin-9-yl]-2-cyclopentene-1-methanol sulfate (salt) (2:1). It has a molecular formula of (C₁₄H₁₈N₆O)₂•H₂SO₄ and a molecular weight of 670.76 g per mol. It has the following structural formula:

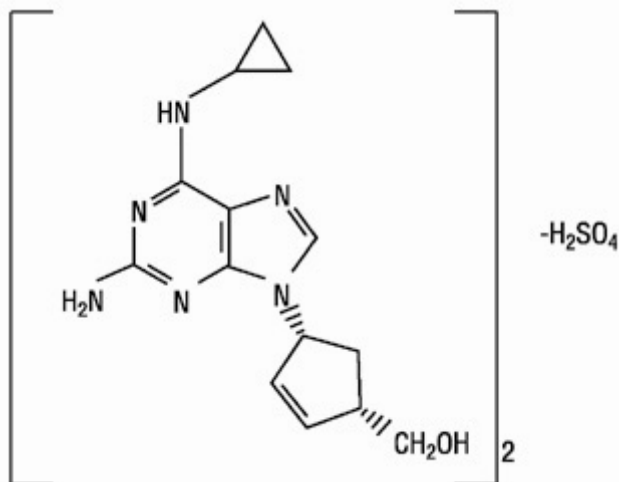

Abacavir sulfate is a white to off-white solid and is soluble in water.

Dolutegravir: The chemical name of dolutegravir sodium is sodium (4*R*,12*aS*)-9-[(2,4-difluorophenyl)methyl]carbamoyl}-4-methyl-6,8-dioxo-3,4,6,8,12,12*a*-hexahydro-2*H*-pyrido[1',2':4,5]pyrazino[2,1-*b*][1,3]oxazin-7-olate. The empirical formula is C₂₀H₁₈F₂N₃NaO₅ and the molecular weight is 441.36 g per mol. It has the following structural formula:

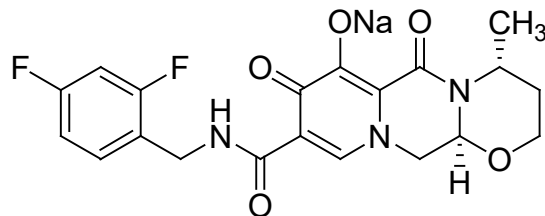

Dolutegravir sodium is a white to light yellow powder and is slightly soluble in water.

Lamivudine: The chemical name of lamivudine is (2R,cis)-4-amino-1-(2-hydroxymethyl-1,3-oxathiolan-5-yl)-(1H)-pyrimidin-2-one. Lamivudine is the (-)enantiomer of a dideoxy analogue of cytidine. Lamivudine has also been referred to as (-)2',3'-dideoxy, 3'-thiacytidine. It has a molecular formula of $C_8H_{11}N_3O_3S$ and a molecular weight of 229.3 g per mol. It has the following structural formula:

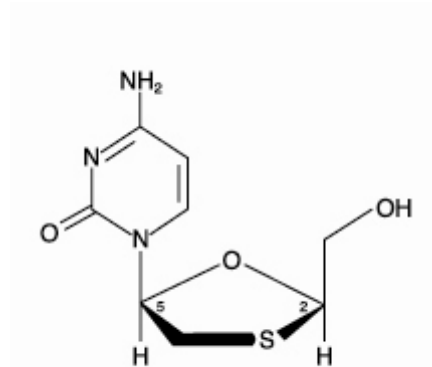

Lamivudine is a white to off-white crystalline solid and is soluble in water.

12 CLINICAL PHARMACOLOGY

12.1 Mechanism of Action

TRIUMEQ is an HIV-1 antiviral agent [see *Microbiology (12.4)*].

12.2 Pharmacodynamics

Effects on Electrocardiogram: A thorough QT trial has been conducted for dolutegravir. Neither the effects of abacavir nor lamivudine as single entities or the combination of abacavir, dolutegravir, and lamivudine on the QT interval have been evaluated.

In a randomized, placebo-controlled, cross-over trial, 42 healthy subjects received single-dose oral administrations of placebo, dolutegravir 250-mg suspension (exposures approximately 3-fold of the 50-mg once-daily dose at steady state), and moxifloxacin 400 mg (active control) in random sequence. After baseline and placebo adjustment, the maximum mean QTc change based on Fridericia correction method (QTcF) for dolutegravir was 2.4 msec (1-sided 95% upper CI: 4.9 msec). Dolutegravir did not prolong the QTc interval over 24 hours postdose.

Effects on Renal Function: The effect of dolutegravir on renal function was evaluated in an open-label, randomized, 3-arm, parallel, placebo-controlled trial in healthy subjects (n = 37) who received dolutegravir 50 mg once daily (n = 12), dolutegravir 50 mg twice daily

(n = 13), or placebo once daily (n = 12) for 14 days. A decrease in creatinine clearance, as determined by 24-hour urine collection, was observed with both doses of dolutegravir after 14 days of treatment in subjects who received 50 mg once daily (9% decrease) and 50 mg twice daily (13% decrease). Neither dose of dolutegravir had a significant effect on the actual glomerular filtration rate (determined by the clearance of probe drug, iothexol) or effective renal plasma flow (determined by the clearance of probe drug, para-amino hippurate) compared with the placebo.

12.3 Pharmacokinetics

Pharmacokinetics in Adults: One TRIUMEQ tablet was bioequivalent to one dolutegravir (TIVICAY) tablet (50 mg) plus one abacavir and lamivudine fixed-dose combination tablet (EPZICOM) under fasted conditions in healthy subjects (n = 62).

Abacavir: Following oral administration, abacavir is rapidly absorbed and extensively distributed. After oral administration of a single dose of 600 mg of abacavir in 20 subjects, C_{max} was 4.26 ± 1.19 mcg per mL (mean \pm SD) and AUC_{∞} was 11.95 ± 2.51 mcg•hour per mL. Binding of abacavir to human plasma proteins is approximately 50% and was independent of concentration. Total blood and plasma drug-related radioactivity concentrations are identical, demonstrating that abacavir readily distributes into erythrocytes. The primary routes of elimination of abacavir are metabolism by alcohol dehydrogenase to form the 5'-carboxylic acid and glucuronyl transferase to form the 5'-glucuronide. In single-dose trials, the observed elimination half-life ($t_{1/2}$) was 1.54 ± 0.63 hours. After intravenous administration, total clearance was 0.80 ± 0.24 L per hour per kg (mean \pm SD).

Dolutegravir: Following oral administration of dolutegravir, peak plasma concentrations were observed 2 to 3 hours postdose. With once-daily dosing, pharmacokinetic steady state is achieved within approximately 5 days with average accumulation ratios for AUC, C_{max} , and C_{24h} ranging from 1.2 to 1.5. Dolutegravir is a P-glycoprotein substrate in vitro. The absolute bioavailability of dolutegravir has not been established. Dolutegravir is highly bound (greater than or equal to 98.9%) to human plasma proteins based on in vivo data and binding is independent of plasma concentration of dolutegravir. The apparent volume of distribution (Vd/F) following 50-mg once-daily administration is estimated at 17.4 L based on a population pharmacokinetic analysis.

Dolutegravir is primarily metabolized via UGT1A1 with some contribution from CYP3A. After a single oral dose of [^{14}C] dolutegravir, 53% of the total oral dose is excreted unchanged in the feces. Thirty-one percent of the total oral dose is excreted in the urine, represented by an ether glucuronide of dolutegravir (18.9% of total dose), a metabolite formed by oxidation at the benzylic carbon (3.0% of total dose), and its hydrolytic N-dealkylation product (3.6% of total dose). Renal elimination of unchanged drug was less than 1% of the dose. Dolutegravir has a terminal half-life of approximately 14 hours and an apparent clearance (CL/F) of 1.0 L per hour based on population pharmacokinetic analyses.

The pharmacokinetic properties of dolutegravir have been evaluated in healthy adult subjects and HIV-1–infected adult subjects. Exposure to dolutegravir was generally similar between healthy subjects and HIV-1–infected subjects.

Table 6. Dolutegravir Steady-state Pharmacokinetic Parameter Estimates in HIV-1–Infected Adults

Parameter	50 mg Once Daily Geometric Mean (%CV)
AUC ₍₀₋₂₄₎ (mcg•h/mL)	53.6 (27)
C _{max} (mcg/mL)	3.67 (20)
C _{min} (mcg/mL)	1.11 (46)

Cerebrospinal Fluid (CSF): In 11 treatment-naïve subjects on dolutegravir 50 mg daily plus abacavir/lamivudine, the median dolutegravir concentration in CSF was 18 ng per mL (range: 4 ng per mL to 23.2 ng per mL) 2 to 6 hours postdose after 2 weeks of treatment. The clinical relevance of this finding has not been established.

Lamivudine: Following oral administration, lamivudine is rapidly absorbed and extensively distributed. After multiple-dose oral administration of lamivudine 300 mg once daily for 7 days to 60 healthy subjects, steady-state C_{max} (C_{max,ss}) was 2.04 ± 0.54 mcg per mL (mean ± SD) and the 24-hour steady-state AUC (AUC_{24,ss}) was 8.87 ± 1.83 mcg•hour per mL. Binding to plasma protein is low. Approximately 70% of an intravenous dose of lamivudine is recovered as unchanged drug in the urine. Metabolism of lamivudine is a minor route of elimination. In humans, the only known metabolite is the trans-sulfoxide metabolite (approximately 5% of an oral dose after 12 hours). In most single-dose trials in HIV-1–infected subjects, HBV-infected subjects, or healthy subjects with serum sampling for 24 hours after dosing, the observed mean elimination half-life (t_{1/2}) ranged from 5 to 7 hours. In HIV-1–infected subjects, total clearance was 398.5 ± 69.1 mL per min (mean ± SD).

Effect of Food on Oral Absorption: TRIUMEQ may be taken with or without food. Overall, when compared with fasted conditions, administration of TRIUMEQ to healthy adult subjects with a high-fat meal (53% fat, 869 calories) resulted in decreased C_{max} for abacavir and increased C_{max} and AUC for dolutegravir. Lamivudine exposures were not affected by food. With a high-fat meal, the C_{max} of abacavir decreased 23% and the C_{max} and AUC of dolutegravir increased 37% and 48%, respectively.

Special Populations: Renal Impairment: The effect of renal impairment on the combination of abacavir, dolutegravir, and lamivudine has not been evaluated.

Abacavir: The pharmacokinetic properties of abacavir have not been determined in patients with impaired renal function.

Dolutegravir: In a trial comparing 8 subjects with severe renal impairment (CrCl less than 30 mL per min) with 8 matched healthy controls, AUC, C_{max}, and C₂₄ of dolutegravir were decreased by 40%, 23%, and 43%, respectively, compared with those in matched healthy

subjects. The cause of this decrease is unknown. Population pharmacokinetic analysis indicated that mild and moderate renal impairment had no clinically relevant effect on the exposure of dolutegravir.

Lamivudine: The pharmacokinetic properties of lamivudine have been determined in a small group of HIV-1–infected adults with impaired renal function (Table 7).

Table 7. Pharmacokinetic Parameters (Mean ± SD) After a Single 300-mg Oral Dose of Lamivudine in 3 Groups of Adults with Varying Degrees of Renal Function

Parameter	Creatinine Clearance Criterion (Number of Subjects)		
	>60 mL/min (n = 6)	10-30 mL/min (n = 4)	<10 mL/min (n = 6)
Creatinine clearance (mL/min)	111 ± 14	28 ± 8	6 ± 2
C _{max} (mcg/mL)	2.6 ± 0.5	3.6 ± 0.8	5.8 ± 1.2
AUC _∞ (mcg•h/mL)	11.0 ± 1.7	48.0 ± 19	157 ± 74
Cl/F (mL/min)	464 ± 76	114 ± 34	36 ± 11

Hepatic Impairment: The effect of hepatic impairment on the combination of abacavir, dolutegravir, and lamivudine has not been evaluated.

Abacavir: The pharmacokinetics of abacavir have been studied in subjects with mild hepatic impairment (Child-Pugh score 5 to 6). Results showed that there was a mean increase of 89% in the abacavir AUC and an increase of 58% in the half-life of abacavir after a single dose of 600 mg of abacavir. The AUCs of the metabolites were not modified by mild liver disease; however, the rates of formation and elimination of the metabolites were decreased. The safety, efficacy, and pharmacokinetics of abacavir have not been studied in patients with moderate or severe hepatic impairment.

Dolutegravir: In a trial comparing 8 subjects with moderate hepatic impairment (Child- Pugh Score B) with 8 matched healthy controls, exposure of dolutegravir from a single 50-mg dose was similar between the 2 groups. The effect of severe hepatic impairment (Child-Pugh Score C) on the pharmacokinetics of dolutegravir has not been studied.

Lamivudine: The pharmacokinetic properties of lamivudine have been determined in adults with impaired hepatic function. Pharmacokinetic parameters were not altered by diminishing hepatic function. Safety and efficacy of lamivudine have not been established in the presence of decompensated liver disease.

Pediatric Patients: The pharmacokinetics of the combination of abacavir, dolutegravir, and lamivudine in pediatric subjects have not been established.

Geriatric Patients: Population analyses using pooled pharmacokinetic data from adult trials indicated age had no clinically relevant effect on the pharmacokinetics of dolutegravir. The

pharmacokinetics of abacavir or lamivudine have not been studied in subjects older than 65 years.

Gender: There are no significant or clinically relevant gender differences in the pharmacokinetics of the individual components (dolutegravir, abacavir, or lamivudine) based on the available information that was analyzed for each of the individual components.

Race: There are no significant or clinically relevant racial differences in pharmacokinetics of the individual components (dolutegravir, abacavir, or lamivudine) based on the available information that was analyzed for each of the individual components.

Drug Interactions: The drug interaction trials described were conducted with dolutegravir, abacavir, and/or lamivudine as single entities; no drug interaction trials have been conducted using the combination of abacavir, dolutegravir, and lamivudine. No clinically significant drug interactions are expected between dolutegravir, abacavir, and lamivudine.

Dosing recommendations as a result of established and other potentially significant drug-drug interactions with dolutegravir or abacavir are provided in Section 7.3 [see *Drug Interactions (7)*].

Table 8. Summary of Effect of Dolutegravir on the Pharmacokinetics of Coadministered Drugs

Coadministered Drug(s) and Dose(s)	Dose of Dolutegravir	n	Geometric Mean Ratio (90% CI) of Pharmacokinetic Parameters of Coadministered Drug with/without Dolutegravir No Effect = 1.00		
			C _{max}	AUC	C _τ or C ₂₄
Ethinyl estradiol 0.035 mg	50 mg twice daily	15	0.99 (0.91 to 1.08)	1.03 (0.96 to 1.11)	1.02 (0.93 to 1.11)
Methadone 16 to 150 mg	50 mg twice daily	11	1.00 (0.94 to 1.06)	0.98 (0.91 to 1.06)	0.99 (0.91 to 1.07)
Midazolam 3 mg	25 mg once daily	10	–	0.95 (0.79 to 1.15)	–
Norelgestromin 0.25 mg	50 mg twice daily	15	0.89 (0.82 to 0.97)	0.98 (0.91 to 1.04)	0.93 (0.85 to 1.03)
Rilpivirine 25 mg once daily	50 mg once daily	16	1.10 (0.99 to 1.22)	1.06 (0.98 to 1.16)	1.21 (1.07 to 1.38)
Tenofovir disoproxil fumarate 300 mg once daily	50 mg once daily	15	1.09 (0.97 to 1.23)	1.12 (1.01 to 1.24)	1.19 (1.04 to 1.35)

Table 9. Summary of Effect of Coadministered Drugs on the Pharmacokinetics of Dolutegravir

Coadministered Drug(s) and Dose(s)	Dose of Dolutegravir	n	Geometric Mean Ratio (90% CI) of Dolutegravir Pharmacokinetic Parameters with/without Coadministered Drugs No Effect = 1.00		
			C _{max}	AUC	C _τ or C ₂₄
Atazanavir 400 mg once daily	30 mg once daily	12	1.50 (1.40 to 1.59)	1.91 (1.80 to 2.03)	2.80 (2.52 to 3.11)
Atazanavir/ritonavir 300/100 mg once daily	30 mg once daily	12	1.34 (1.25 to 1.42)	1.62 (1.50 to 1.74)	2.21 (1.97 to 2.47)
Tenofovir 300 mg once daily	50 mg once daily	15	0.97 (0.87 to 1.08)	1.01 (0.91 to 1.11)	0.92 (0.82 to 1.04)
Darunavir/ritonavir 600/100 mg twice daily	30 mg once daily	15	0.89 (0.83 to 0.97)	0.78 (0.72 to 0.85)	0.62 (0.56 to 0.69)
Efavirenz 600 mg once daily	50 mg once daily	12	0.61 (0.51 to 0.73)	0.43 (0.35 to 0.54)	0.25 (0.18 to 0.34)
Etravirine 200 mg twice daily	50 mg once daily	16	0.48 (0.43 to 0.54)	0.29 (0.26 to 0.34)	0.12 (0.09 to 0.16)
Etravirine + darunavir/ritonavir 200 mg + 600/100 mg twice daily	50 mg once daily	9	0.88 (0.78 to 1.00)	0.75 (0.69 to 0.81)	0.63 (0.52 to 0.76)
Etravirine + lopinavir/ritonavir 200 mg + 400/100 mg twice daily	50 mg once daily	8	1.07 (1.02 to 1.13)	1.11 (1.02 to 1.20)	1.28 (1.13 to 1.45)
Fosamprenavir/ritonavir 700 mg /100 mg twice daily	50 mg once daily	12	0.76 (0.63 to 0.92)	0.65 (0.54 to 0.78)	0.51 (0.41 to 0.63)
Lopinavir/ritonavir 400/100 mg twice daily	30 mg once daily	15	1.00 (0.94 to 1.07)	0.97 (0.91 to 1.04)	0.94 (0.85 to 1.05)
Antacid (Maalox [®]) simultaneous administration	50 mg single dose	16	0.28 (0.23 to 0.33)	0.26 (0.22 to 0.32)	0.26 (0.21 to 0.31)
Antacid (Maalox [®]) 2 h after dolutegravir	50 mg single dose	16	0.82 (0.69 to 0.98)	0.74 (0.62 to 0.90)	0.70 (0.58 to 0.85)
Calcium carbonate 1,200 mg simultaneous administration (fasted)	50 mg single dose	12	0.63 (0.50 to 0.81)	0.61 (0.47 to 0.80)	0.61 (0.47 to 0.80)
Calcium carbonate 1,200 mg simultaneous administration (fed)	50 mg single dose	11	1.07 (0.83 to 1.38)	1.09 (0.84 to 1.43)	1.08 (0.81 to 1.42)

Coadministered Drug(s) and Dose(s)	Dose of Dolutegravir	n	Geometric Mean Ratio (90% CI) of Dolutegravir Pharmacokinetic Parameters with/without Coadministered Drugs No Effect = 1.00		
			C _{max}	AUC	C _τ or C ₂₄
Calcium carbonate 1,200 mg 2 h after dolutegravir	50 mg single dose	11	1.00 (0.78 to 1.29)	0.94 (0.72 to 1.23)	0.90 (0.68 to 1.19)
Ferrous fumarate 324 mg simultaneous administration (fasted)	50 mg single dose	11	0.43 (0.35 to 0.52)	0.46 (0.38 to 0.56)	0.44 (0.36 to 0.54)
Ferrous fumarate 324 mg simultaneous administration (fed)	50 mg single dose	11	1.03 (0.84 to 1.26)	0.98 (0.81 to 1.20)	1.00 (0.81 to 1.23)
Ferrous fumarate 324 mg 2 h after dolutegravir	50 mg single dose	10	0.99 (0.81 to 1.21)	0.95 (0.77 to 1.15)	0.92 (0.74 to 1.13)
Multivitamin (One-A-Day [®]) simultaneous administration	50 mg single dose	16	0.65 (0.54 to 0.77)	0.67 (0.55 to 0.81)	0.68 (0.56 to 0.82)
Omeprazole 40 mg once daily	50 mg single dose	12	0.92 (0.75 to 1.11)	0.97 (0.78 to 1.20)	0.95 (0.75 to 1.21)
Prednisone 60 mg once daily with taper	50 mg once daily	12	1.06 (0.99 to 1.14)	1.11 (1.03 to 1.20)	1.17 (1.06 to 1.28)
Rifampin ^a 600 mg once daily	50 mg twice daily	11	0.57 (0.49 to 0.65)	0.46 (0.38 to 0.55)	0.28 (0.23 to 0.34)
Rifampin ^b 600 mg once daily	50 mg twice daily	11	1.18 (1.03 to 1.37)	1.33 (1.15 to 1.53)	1.22 (1.01 to 1.48)
Rifabutin 300 mg once daily	50 mg once daily	9	1.16 (0.98 to 1.37)	0.95 (0.82 to 1.10)	0.70 (0.57 to 0.87)
Rilpivirine 25 mg once daily	50 mg once daily	16	1.13 (1.06 to 1.21)	1.12 (1.05 to 1.19)	1.22 (1.15 to 1.30)
Tipranavir/ritonavir 500/200 mg twice daily	50 mg once daily	14	0.54 (0.50 to 0.57)	0.41 (0.38 to 0.44)	0.24 (0.21 to 0.27)
Telaprevir 750 mg every 8 hours	50 mg once daily	15	1.18 (1.11 to 1.26)	1.25 (1.19 to 1.31)	1.40 (1.29 to 1.51)
Boceprevir 800 mg every 8 hours	50 mg once daily	13	1.05 (0.96 to 1.15)	1.07 (0.95 to 1.20)	1.08 (0.91 to 1.28)

^a Comparison is rifampin taken with dolutegravir 50 mg twice daily compared with dolutegravir 50 mg twice daily.

^b Comparison is rifampin taken with dolutegravir 50 mg twice daily compared with dolutegravir 50 mg once daily.

Abacavir or Lamivudine: The drug interactions described are based on trials conducted with abacavir or lamivudine as single entities.

Interferon Alfa: There was no significant pharmacokinetic interaction between lamivudine and interferon alfa in a trial of 19 healthy male subjects.

Methadone: In a trial of 11 HIV-1-infected subjects receiving methadone-maintenance therapy (40 mg and 90 mg daily), with 600 mg of abacavir twice daily (twice the currently recommended dose), oral methadone clearance increased 22% (90% CI: 6% to 42%) [see *Drug Interactions (7.3)*].

Ribavirin: In vitro data indicate ribavirin reduces phosphorylation of lamivudine, stavudine, and zidovudine. However, no pharmacokinetic (e.g., plasma concentrations or intracellular triphosphorylated active metabolite concentrations) or pharmacodynamic (e.g., loss of HIV-1/HCV virologic suppression) interaction was observed when ribavirin and lamivudine (n = 18), stavudine (n = 10), or zidovudine (n = 6) were coadministered as part of a multi-drug regimen to HIV-1/HCV co-infected subjects [see *Warnings and Precautions (5.4)*].

Abacavir, Lamivudine, Zidovudine: Fifteen HIV-1–infected subjects were enrolled in a crossover-designed drug interaction trial evaluating single doses of abacavir (600 mg), lamivudine (150 mg), and zidovudine (300 mg) alone or in combination. Analysis showed no clinically relevant changes in the pharmacokinetics of abacavir with the addition of lamivudine or zidovudine or the combination of lamivudine and zidovudine. Lamivudine exposure (AUC decreased 15%) and zidovudine exposure (AUC increased 10%) did not show clinically relevant changes with concurrent abacavir.

Lamivudine and Zidovudine: No clinically significant alterations in lamivudine or zidovudine pharmacokinetics were observed in 12 asymptomatic HIV-1-infected adult patients given a single dose of zidovudine (200 mg) in combination with multiple doses of lamivudine (300 mg every 12 h).

The effects of other coadministered drugs on abacavir or lamivudine are provided in Table 10.

Table 10. Effect of Coadministered Drugs on Abacavir or Lamivudine

Coadministered Drug and Dose	Drug and Dose	n	Concentrations of Abacavir or Lamivudine		Concentration of Coadministered Drug
			AUC	Variability	
Ethanol 0.7 g/kg	Abacavir Single 600 mg	24	↑41%	90% CI: 35% to 48%	↔ ^a
Nelfinavir 750 mg every 8 h x 7 to 10 days	Lamivudine Single 150 mg	11	↑10%	95% CI: 1% to 20%	↔
Trimethoprim 160 mg/ Sulfamethoxazole 800 mg daily x 5 days	Lamivudine Single 300 mg	14	↑43%	90% CI: 32% to 55%	↔

↑ = Increase; ↔ = no significant change; AUC = area under the concentration versus time curve; CI = confidence interval.

^a The drug-drug interaction was only evaluated in males.

12.4 Microbiology

Mechanism of Action: *Dolutegravir*: Dolutegravir inhibits HIV integrase by binding to the integrase active site and blocking the strand transfer step of retroviral DNA integration which is essential for the HIV replication cycle. Strand transfer biochemical assays using purified recombinant HIV-1 integrase and pre-processed substrate DNA resulted in IC₅₀ values of 2.7 nM and 12.6 nM.

Abacavir: Abacavir is a carbocyclic synthetic nucleoside analogue. Abacavir is converted by cellular enzymes to the active metabolite, carbovir triphosphate (CBV-TP), an analogue of deoxyguanosine-5'-triphosphate (dGTP). CBV-TP inhibits the activity of HIV-1 reverse transcriptase (RT) both by competing with the natural substrate dGTP and by its incorporation into viral DNA.

Lamivudine: Lamivudine is a synthetic nucleoside analogue. Intracellularly lamivudine is phosphorylated to its active 5'-triphosphate metabolite, lamivudine triphosphate (3TC-TP). The principal mode of action of 3TC-TP is inhibition of RT via DNA chain termination after incorporation of the nucleotide analogue.

Antiviral Activity in Cell Culture: *Dolutegravir*: Dolutegravir exhibited antiviral activity against laboratory strains of wild-type HIV-1 with mean concentration of drug necessary to effect viral replication by 50 percent (EC₅₀) values of 0.5 nM (0.21 ng per mL) to 2.1 nM (0.85 ng per mL) in peripheral blood mononuclear cells (PBMCs) and MT-4 cells. Dolutegravir exhibited antiviral activity against 13 clinically diverse clade B isolates with a median EC₅₀ value of 0.54 nM (range: 0.41 to 0.60 nM) in a viral susceptibility assay using the integrase coding region from clinical isolates. Dolutegravir demonstrated antiviral activity in cell culture against a panel of HIV-1 clinical isolates with median EC₅₀ values of 0.18 nM (n = 3, range: 0.09 to 0.5 nM), 0.08 nM (n = 5, range: 0.05 to 2.14 nM) 0.12 nM (n = 4, range: 0.05 to 0.51 nM), 0.17 nM (n = 3, range: 0.16 to 0.35 nM), 0.24 nM (n = 3, range: 0.09 to 0.32 nM), 0.17 nM (range: 0.07 to 0.44 nM), 0.2 nM (n = 3, range: 0.02 to 0.87 nM), and 0.42 nM (n = 3, range: 0.41 to 1.79 nM) for clades A, B, C, D, E, F, and G, and group O viruses, respectively. Dolutegravir EC₅₀ values against three HIV-2 clinical isolates in PBMC assays ranged from 0.09 nM to 0.61 nM.

Abacavir: The antiviral activity of abacavir against HIV-1 was assessed in a number of cell lines including in primary monocytes/macrophages and PBMCs. EC₅₀ values ranged from 3.7 to 5.8 μM (1 μM = 0.28 mcg per mL) and 0.07 to 1.0 μM against HIV-1_{IIIB} and HIV-1_{BaL}, respectively, and was 0.26 ± 0.18 μM against 8 clinical isolates. The median EC₅₀ values of abacavir were 344 nM (range: 14.8 to 676 nM), 16.9 nM (range: 5.9 to 27.9 nM), 8.1 nM (range: 1.5 to 16.7 nM), 356 nM (range: 35.7 to 396 nM), 105 nM (range: 28.1 to 168 nM), 47.6 nM (range: 5.2 to 200 nM), 51.4 nM (range: 7.1 to 177 nM), and 282 nM (range: 22.4 to 598 nM)

against HIV-1 clades A-G and group O viruses (n = 3 except n = 2 for clade B), respectively. The EC₅₀ values against HIV-2 isolates (n = 4), ranged from 0.024 to 0.49 μM.

Lamivudine: The antiviral activity of lamivudine against HIV-1 was assessed in a number of cell lines including monocytes and PBMCs using standard susceptibility assays. EC₅₀ values were in the range of 0.003 to 15 μM (1 μM = 0.23 mcg per mL). The median EC₅₀ values of lamivudine were 60 nM (range: 20 to 70 nM), 35 nM (range: 30 to 40 nM), 30 nM (range: 20 to 90 nM), 20 nM (range: 3 to 40 nM), 30 nM (range: 1 to 60 nM), 30 nM (range: 20 to 70 nM), 30 nM (range: 3 to 70 nM), and 30 nM (range: 20 to 90 nM) against HIV-1 clades A-G and group O viruses (n = 3 except n = 2 for clade B) respectively. The EC₅₀ values against HIV-2 isolates (n = 4) from 0.003 to 0.120 μM in PBMCs.

Antiviral Activity in Combination with Other Antiviral Agents: Neither dolutegravir, abacavir, nor lamivudine were antagonistic to all tested anti-HIV agents. See full prescribing information for ZIAGEN (abacavir), TIVICAY (dolutegravir), and EPIVIR (lamivudine).

Resistance in Cell Culture: Dolutegravir: Dolutegravir-resistant viruses were selected in cell culture starting from different wild-type HIV-1 strains and clades. Amino acid substitutions E92Q, G118R, S153F or Y, G193E or R263K emerged in different passages and conferred decreased susceptibility to dolutegravir of up to 4-fold.

Abacavir and Lamivudine: HIV-1 isolates with reduced susceptibility to the combination of abacavir and lamivudine have been selected in cell culture with amino acid substitutions M184V/I, K65R, L74V, and Y115F in HIV-1 RT. Substitution at M184I or V causes high-level resistance to lamivudine and approximately 2-fold decreased susceptibility to abacavir. Substitutions K65R, L74M, or Y115F with M184I or V conferred a 7-fold to 8-fold reduction in abacavir susceptibility, and combinations of three substitutions were required to confer more than an 8-fold reduction in susceptibility.

Resistance in Clinical Subjects: Dolutegravir: No subjects in the treatment arm receiving dolutegravir + EPZICOM of SINGLE (treatment-naïve trial) had a detectable decrease in susceptibility to dolutegravir or background NRTIs in the resistance analysis subset (n = 9 with HIV-1 RNA greater than 400 copies per mL at failure or last visit through Week 96 and having resistance data). One subject in SINGLE with 275 copies per mL HIV-1 RNA had a treatment-emergent integrase substitution (E157Q/P) detected at Week 24, but no corresponding decrease in dolutegravir susceptibility. No treatment-emergent genotypic resistance to abacavir and lamivudine, components of TRIUMEQ, was observed in the arm receiving dolutegravir + EPZICOM in the SINGLE trial.

Cross Resistance: Dolutegravir: The single INSTI-resistance substitutions T66K, I151L, and S153Y conferred a greater than 2-fold decrease in dolutegravir susceptibility (range: 2.3-fold to 3.6-fold from reference). Combinations of multiple substitutions T66K/L74M, E92Q/N155H, G140C/Q148R, G140S/Q148H, R or K, Q148R/N155H, T97A/G140S/Q148, and substitutions at E138/G140/Q148 showed a greater than 2-fold decrease in dolutegravir susceptibility (range: 2.5-fold to 21-fold from reference). In HIV-2 mutants, combinations of substitutions A153G/N155H/S163G and E92Q/T97A/N155H/S163D conferred 4-fold decreases

in dolutegravir susceptibility, and E92Q/N155H and G140S/Q148R showed 8.5-fold and 17-fold decreases in dolutegravir susceptibility, respectively.

Abacavir and Lamivudine: Cross-resistance has been observed among NRTIs. The combination of abacavir/lamivudine has demonstrated decreased susceptibility to viruses with the substitutions K65R with or without the M184V/I substitution, viruses with L74V plus the M184V/I substitution, and viruses with thymidine analog mutations (TAMs: M41L, D67N, K70R, L210W, T215Y/F, K219 E/R/H/Q/N) plus M184V. An increasing number of TAMs is associated with a progressive reduction in abacavir susceptibility.

13 NONCLINICAL TOXICOLOGY

13.1 Carcinogenesis, Mutagenesis, Impairment of Fertility

Carcinogenicity: *Dolutegravir:* Two-year carcinogenicity studies in mice and rats were conducted with dolutegravir. Mice were administered doses of up to 500 mg per kg, and rats were administered doses of up to 50 mg per kg. In mice, no significant increases in the incidence of drug-related neoplasms were observed at the highest doses tested, resulting in dolutegravir AUC exposures approximately 26-fold higher than those in humans at the recommended dose of 50 mg once daily. In rats, no increases in the incidence of drug-related neoplasms were observed at the highest dose tested, resulting in dolutegravir AUC exposures 17-fold and 30-fold higher in males and females, respectively, than those in humans at the recommended dose of 50 mg once daily.

Abacavir: Abacavir was administered orally at 3 dosage levels to separate groups of mice and rats in 2-year carcinogenicity studies. Results showed an increase in the incidence of malignant and non-malignant tumors. Malignant tumors occurred in the preputial gland of males and the clitoral gland of females of both species, and in the liver of female rats. In addition, non-malignant tumors also occurred in the liver and thyroid gland of female rats. These observations were made at systemic exposures in the range of 7 to 28 times the human exposure at the recommended dose of 600 mg.

Lamivudine: Long-term carcinogenicity studies with lamivudine in mice and rats showed no evidence of carcinogenic potential at exposures up to 12 times (mice) and 57 times (rats) the human exposures at the recommended dose of 300 mg.

Mutagenicity: *Dolutegravir:* Dolutegravir was not genotoxic in the bacterial reverse mutation assay, mouse lymphoma assay, or in the in vivo rodent micronucleus assay.

Abacavir: Abacavir induced chromosomal aberrations both in the presence and absence of metabolic activation in an in vitro cytogenetic study in human lymphocytes. Abacavir was mutagenic in the absence of metabolic activation, although it was not mutagenic in the presence of metabolic activation in an L5178Y mouse lymphoma assay. Abacavir was clastogenic in males and not clastogenic in females in an in vivo mouse bone marrow micronucleus assay. Abacavir was not mutagenic in bacterial mutagenicity assays in the presence and absence of metabolic activation.

Lamivudine: Lamivudine was mutagenic in an L5178Y mouse lymphoma assay and clastogenic in a cytogenetic assay using cultured human lymphocytes. Lamivudine was not mutagenic in a microbial mutagenicity assay, in an in vitro cell transformation assay, in a rat micronucleus test, in a rat bone marrow cytogenetic assay, and in an assay for unscheduled DNA synthesis in rat liver.

Impairment of Fertility: Dolutegravir, abacavir, or lamivudine did not affect male or female fertility in rats at doses associated with exposures approximately 44, 9, or 112 times (respectively) higher than the exposures in humans at the doses of 50 mg, 600 mg, and 300 mg (respectively).

13.2 Animal Toxicology and/or Pharmacology

Myocardial degeneration was found in mice and rats following administration of abacavir for 2 years. The systemic exposures were equivalent to 7 to 21 times the expected systemic exposure in humans at a dose of 600 mg. The clinical relevance of this finding has not been determined.

14 CLINICAL STUDIES

14.1 Adult Subjects

The efficacy of TRIUMEQ is supported by data from a randomized, controlled trial in antiretroviral treatment-naïve subjects, SINGLE (ING114467) and other trials in treatment-naïve subjects. See full prescribing information for TIVICAY. The efficacy of dolutegravir, in combination with at least two active background regimens in treatment-experienced, INSTI-naïve subjects is supported by data from SAILING (ING111762) (refer to the prescribing information for TIVICAY).

Treatment-naïve Subjects: In SINGLE, 833 subjects were randomized and received at least 1 dose of either TIVICAY 50 mg once daily with fixed-dose abacavir and lamivudine (EPZICOM) or fixed-dose efavirenz/emtricitabine/tenofovir disoproxil fumarate (ATRIPLA). At baseline, the median age of subjects was 35 years, 16% female, 32% non-white, 7% had hepatitis C co-infection (hepatitis B virus co-infection was excluded), 4% were CDC Class C (AIDS), 32% had HIV-1 RNA greater than 100,000 copies per mL, and 53% had CD4+ cell count less than 350 cells per mm³; these characteristics were similar between treatment groups. Week 96 outcomes for SINGLE are provided in Table 11.

Table 11. Virologic Outcomes of Randomized Treatment in SINGLE at 96 Weeks (Snapshot Algorithm)

	TIVICAY + EPZICOM Once Daily (N = 414)	ATRIPLA Once Daily (N = 419)
HIV-1 RNA <50 copies/mL	80%	72%
Treatment difference ^a	8.0% (95% CI: 2.3%, 13.8%)	
Virologic nonresponse^b	7%	8%
No virologic data	12%	20%

Reasons		
Discontinued study/study drug due to adverse event or death ^c	3%	11%
Discontinued study/study drug for other reasons ^d	9%	8%
Missing data during window but on study	<1%	0
Proportion (%) of Subjects with HIV-1 RNA <50 copies/mL by Baseline Category		
Plasma viral load (copies/mL)^e		
≤100,000	85%	73%
>100,000	71%	72%
Gender		
Male	81%	75%
Female	76%	56%
Race		
White	79%	77%
African-American/African Heritage/Other	83%	62%

^a Adjusted for pre-specified stratification factors.

^b Includes subjects who discontinued prior to Week 96 for lack or loss of efficacy, and subjects who were HIV-1 RNA greater than or equal to 50 copies per mL in the Week 96 window.

^c Includes subjects who discontinued due to an adverse event or death at any time point from Day 1 through the Week 96 window if this resulted in no virologic data on treatment during the Week 96 window.

^d Other includes reasons such as withdrew consent, loss to follow-up, moved, and protocol deviation.

^e The proportion of subjects who had no virologic data due to reasons such as withdrew consent, lost to follow-up, moved, and protocol deviation was 10% (TIVICAY + EPZICOM) and 6% (ATRIPLA) in the greater than 100,000–copies-per-mL-group and 8% and 9% (respectively) in the less than or equal to 100,000–copies-per-mL-group.

Treatment differences were maintained across baseline characteristics including CD4+ cell count, age, gender, and race. The adjusted mean changes in CD4+ cell counts from baseline were 325 cells per mm³ in the group receiving TIVICAY + EPZICOM and 281 cells per mm³ for the ATRIPLA group at 96 weeks. The adjusted difference between treatment arms and 95% CI was 44.0 cells per mm³ (14.3 cells per mm³, 73.6 cells per mm³) (adjusted for pre-specified stratification factors: baseline HIV-1 RNA, baseline CD4+ cell count, and multiplicity).

Treatment-experienced: In SAILING, there were 715 subjects included in the efficacy and safety analyses (see full prescribing information for TIVICAY). At Week 48, 71% of subjects randomized to TIVICAY plus background regimen versus 64% of subjects randomized to raltegravir plus background regimen had HIV-1 RNA less than 50 copies per mL [treatment difference and 95% CI: 7.4% (0.7%, 14.2%)].

16 HOW SUPPLIED/STORAGE AND HANDLING

TRIUMEQ tablets, 600 mg of abacavir as abacavir sulfate, 50 mg of dolutegravir as dolutegravir sodium, and 300 mg lamivudine, are purple, oval, film-coated, biconvex tablets debossed with “572 Tri” on one side.

Bottle of 30 with child-resistant closure NDC 49702-231-13.

Store and dispense in the original package, protect from moisture, and keep the bottle tightly closed. Do not remove desiccant.

Store at 25°C (77°F); excursions permitted 15° to 30°C (59° to 86°F). [See USP Controlled Room Temperature].

17 PATIENT COUNSELING INFORMATION

Advise the patient to read the FDA-approved patient labeling (Medication Guide).

Drug Interactions: Do not coadminister TRIUMEQ with dofetilide (TIKOSYN[®]) because the interaction between dofetilide and dolutegravir can result in potentially life-threatening adverse events [see *Contraindications (4)*]. Patients should be advised to report to their healthcare provider the use of any other prescription or nonprescription medication or herbal products.

Hypersensitivity Reaction: Inform patients:

- that a Medication Guide and Warning Card summarizing the symptoms of the abacavir hypersensitivity reaction and other product information will be dispensed by the pharmacist with each new prescription and refill of TRIUMEQ, and instruct the patient to read the Medication Guide and Warning Card every time to obtain any new information that may be present about TRIUMEQ. (The complete text of the Medication Guide is reprinted at the end of this document.)
- to carry the Warning Card with them.
- how to identify a hypersensitivity reaction [see *Warnings and Precautions (5.1)*, *Medication Guide*].
- that if they develop symptoms consistent with a hypersensitivity reaction they should call their doctor right away to determine if they should stop taking TRIUMEQ.
- that a hypersensitivity reaction can worsen and lead to hospitalization or death if TRIUMEQ is not immediately discontinued.
- to not restart TRIUMEQ or any other abacavir-containing product following a hypersensitivity reaction because more severe symptoms can occur within hours and may include life-threatening hypotension and death.
- that a hypersensitivity reaction is usually reversible if it is detected promptly and TRIUMEQ is stopped right away.
- that if they have interrupted TRIUMEQ for reasons other than symptoms of hypersensitivity (for example, those who have an interruption in drug supply), a serious or fatal hypersensitivity reaction may occur with reintroduction of abacavir.

- to not restart TRIUMEQ or any other abacavir-containing product without medical consultation and only if medical care can be readily accessed by the patient or others.
- to not restart TRIUMEQ or any other dolutegravir-containing product following a hypersensitivity reaction to TRIUMEQ.

Inform patients that they should not take TRIUMEQ with ATRIPLA, COMBIVIR[®], COMPLERA[®], EMTRIVA[®], EPIVIR, EPIVIR-HBV[®], EPZICOM, STRIBILD[®], TRIZIVIR, TRUVADA[®], or ZIAGEN.

Lactic Acidosis/Hepatomegaly: Inform patients that some HIV medicines, including TRIUMEQ, can cause a rare, but serious condition called lactic acidosis with liver enlargement (hepatomegaly) [*see Warnings and Precautions (5.2)*].

Patients with Hepatitis B or C Co-infection: Patients with underlying hepatitis B or C may be at increased risk for worsening or development of transaminase elevations with use of TRIUMEQ and advise patients to have laboratory testing before and during therapy [*see Warnings and Precautions (5.3)*].

Advise patients co-infected with HIV-1 and HBV that worsening of liver disease has occurred in some cases when treatment with lamivudine was discontinued. Advise patients to discuss any changes in regimen with their physician [*see Warnings and Precautions (5.3)*].

Inform patients with HIV-1/HCV co-infection that hepatic decompensation (some fatal) has occurred in HIV-1/HCV co-infected patients receiving combination antiretroviral therapy for HIV-1 and interferon alfa with or without ribavirin [*see Warnings and Precautions (5.4)*].

Immune Reconstitution Syndrome: In some patients with advanced HIV infection, signs and symptoms of inflammation from previous infections may occur soon after anti-HIV treatment is started. It is believed that these symptoms are due to an improvement in the body's immune response, enabling the body to fight infections that may have been present with no obvious symptoms. Advise patients to inform their healthcare provider immediately of any symptoms of infection [*see Warnings and Precautions (5.5)*].

Redistribution/Accumulation of Body Fat: Inform patients that redistribution or accumulation of body fat may occur in patients receiving antiretroviral therapy and that the cause and long-term health effects of these conditions are not known at this time [*see Warnings and Precautions (5.6)*].

Information About HIV-1 Infection: TRIUMEQ is not a cure for HIV-1 infection and patients may continue to experience illnesses associated with HIV-1 infection, including opportunistic infections. Patients must remain on continuous HIV therapy to control HIV-1 infection and decrease HIV-related illness. Inform patients that sustained decreases in plasma HIV RNA have been associated with a reduced risk of progression to AIDS and death.

Advise patients to remain under the care of a physician when using TRIUMEQ.

Advise patients to take all HIV medications exactly as prescribed.

Advise patients to avoid doing things that can spread HIV-1 infection to others.

Advise patients not to re-use or share needles or other injection equipment.

Advise patients not to share personal items that can have blood or body fluids on them, like toothbrushes and razor blades.

Always practice safer sex by using a latex or polyurethane condom to lower the chance of sexual contact with semen, vaginal secretions, or blood.

Female patients should be advised not to breastfeed because it is not known if TRIUMEQ can be passed to your baby in your breast milk and whether it could harm your baby. Mothers with HIV-1 should not breastfeed because HIV-1 can be passed to the baby in the breast milk.

Instruct patients to read the Medication Guide before starting TRIUMEQ and to reread it each time the prescription is renewed. Instruct patients to inform their physician or pharmacist if they develop any unusual symptom, or if any known symptom persists or worsens.

Instruct patients that if they miss a dose, they should take it as soon as they remember. If they do not remember until it is within 4 hours of the time for the next dose, they should be instructed to skip the missed dose and go back to the regular schedule. Patients should not double their next dose or take more than the prescribed dose.

Instruct patients to store TRIUMEQ in the original package, protect from moisture, and keep the bottle tightly closed. Do not remove desiccant.

COMBIVIR, EPIVIR, EPZICOM, TIVICAY, TRIUMEQ, TRIZIVIR, and ZIAGEN are registered trademarks of the ViiV Healthcare group of companies.

EPIVIR-HBV is a registered trademark of the GSK group of companies.

The other brands listed are trademarks of their respective owners and are not trademarks of the ViiV Healthcare group of companies. The makers of these brands are not affiliated with and do not endorse the ViiV Healthcare group of companies or its products.

Manufactured for



ViiV Healthcare

Research Triangle Park, NC 27709

by:



GlaxoSmithKline
Research Triangle Park, NC 27709

Lamivudine is manufactured under agreement from
Shire Pharmaceuticals Group plc
Basingstoke, UK

©2014, the ViiV Healthcare group of companies. All rights reserved.

TRM:XPI

MEDICATION GUIDE
TRIUMEQ® (TRI-u-meck)
(abacavir, dolutegravir, and lamivudine)
Tablets

Read this Medication Guide before you start taking TRIUMEQ and each time you get a refill. There may be new information. This information does not take the place of talking to your healthcare provider about your medical condition or your treatment. Be sure to carry your TRIUMEQ Warning Card with you at all times.

What is the most important information I should know about TRIUMEQ?

- **Serious allergic reaction (hypersensitivity reaction).** TRIUMEQ contains abacavir (also contained in EPZICOM®, TRIZIVIR®, and ZIAGEN®). Patients taking TRIUMEQ may have a serious allergic reaction (hypersensitivity reaction) that can cause death. Your risk of this allergic reaction to abacavir is much higher if you have a gene variation called HLA-B*5701. Your healthcare provider can determine with a blood test if you have this gene variation.

If you get a symptom from 2 or more of the following groups while taking TRIUMEQ, call your healthcare provider right away to find out if you should stop taking TRIUMEQ.

	Symptom(s)
Group 1	Fever
Group 2	Rash
Group 3	Nausea, vomiting, diarrhea, abdominal (stomach area) pain
Group 4	Generally ill feeling, extreme tiredness, or achiness
Group 5	Shortness of breath, cough, sore throat

A list of these symptoms is on the Warning Card your pharmacist gives you. **Carry this Warning Card with you at all times.**

If you stop TRIUMEQ because of an allergic reaction, never take TRIUMEQ or any other medicines that contain abacavir or dolutegravir

(EPZICOM, ZIAGEN, TRIZIVIR, or TIVICAY®) again. If you take TRIUMEQ or any other abacavir-containing medicine again after you have had an allergic reaction, **within hours** you may get **life-threatening symptoms** that may include **very low blood pressure** or **death**. If you stop TRIUMEQ for any other reason, even for a few days, and you are not allergic to TRIUMEQ, talk with your healthcare provider before taking it again. Taking TRIUMEQ again can cause a serious allergic or life-threatening reaction, even if you never had an allergic reaction to it before.

If your healthcare provider tells you that you can take TRIUMEQ again, start taking it when you are around medical help or people who can call a healthcare provider if you need one.

- **Build-up of acid in your blood (lactic acidosis).** Lactic acidosis can happen in some people who take TRIUMEQ. Lactic acidosis is a serious medical emergency that can lead to death.

Lactic acidosis can be hard to identify early, because the symptoms could seem like symptoms of other health problems.

Call your healthcare provider right away if you get the following symptoms that could be signs of lactic acidosis:

- feel very weak or tired
 - have unusual (not normal) muscle pain
 - have trouble breathing
 - have stomach pain with nausea and vomiting
 - feel cold, especially in your arms and legs
 - feel dizzy or lightheaded
 - have a fast or irregular heartbeat
- **Severe liver problems.** Severe liver problems can happen in people who take TRIUMEQ. In some cases these severe liver problems can lead to death. Your liver may become large (hepatomegaly) and you may develop fat in your liver (steatosis).

Call your healthcare provider right away if you get any of the following signs or symptoms of liver problems:

- your skin or the white part of your eyes turns yellow
- dark "tea-colored" urine
- light colored stools (bowel movements)
- nausea
- itching
- stomach-area pain

You may be more likely to get lactic acidosis or serious liver problems if you are female, very overweight, or have been taking nucleoside analogue medicines for a long time.

- **Worsening of hepatitis B virus in people who have HIV-1 infection.** If you have HIV-1 and hepatitis B virus infections, your hepatitis virus infection may get worse if you stop taking TRIUMEQ. To help avoid this: Take TRIUMEQ exactly as prescribed.
 - Do not run out of TRIUMEQ.
 - Do not stop TRIUMEQ without talking to your healthcare provider.
 - Your healthcare provider should monitor your health and do regular blood tests to check your liver for at least several months if you stop taking TRIUMEQ.
- **Resistant Hepatitis B Virus (HBV).** If you have HIV-1 and hepatitis B, the hepatitis B virus can change (mutate) during your treatment with TRIUMEQ and become harder to treat (resistant).
- **Use with interferon and ribavirin-based regimens.** Worsening of liver disease has happened in people infected with HIV-1 and hepatitis C virus who are taking anti-HIV medicines and are also being treated for hepatitis C with interferon with or without ribavirin. If you are taking TRIUMEQ and interferon with or without ribavirin, tell your healthcare provider if you have any new symptoms.

What is TRIUMEQ?

TRIUMEQ is a prescription medicine used to treat HIV-1 (Human Immunodeficiency Virus-type 1) infection. TRIUMEQ contains 3 prescription medicines: abacavir (ZIAGEN), dolutegravir (TIVICAY), and lamivudine (EPIVIR®).

- TRIUMEQ is not for use by itself in people who have or have had resistance to abacavir, dolutegravir, or lamivudine.

It is not known if TRIUMEQ is safe and effective in children.

TRIUMEQ may help:

- reduce the amount of HIV-1 in your blood. This is called “viral load”.
- increase the number of white blood cells called CD4+ (T) cells in your blood, which help fight off other infections.

Reducing the amount of HIV-1 and increasing the CD4+ (T) cells in your blood may help improve your immune system. This may reduce your risk of death or getting infections that can happen when your immune system is weak (opportunistic infections).

TRIUMEQ does not cure HIV-1 infection or AIDS. You must stay on continuous HIV-1 therapy to control HIV-1 infection and decrease HIV-related illnesses.

Avoid doing things that can spread HIV-1 infection to others.

- Do not share or re-use needles or other injection equipment.
- Do not share personal items that can have blood or body fluids on them, like toothbrushes and razor blades.
- Do not have any kind of sex without protection. Always practice safer sex by using a latex or polyurethane condom to lower the chance of sexual contact with semen, vaginal secretions, or blood.

Ask your healthcare provider if you have any questions about how to prevent passing HIV to other people.

Who should not take TRIUMEQ?

Do not take TRIUMEQ if you:

- have a certain type of gene variation called the HLA-B*5701 allele. Your healthcare provider will test you for this before prescribing treatment with TRIUMEQ.
- have ever had an allergic reaction to abacavir, dolutegravir, or lamivudine
- take dofetilide (TIKOSYN®). Taking TRIUMEQ and dofetilide (TIKOSYN) can cause side effects that may be life-threatening.
- have certain liver problems

What should I tell my healthcare provider before taking TRIUMEQ?

Before you take TRIUMEQ, tell your healthcare provider if you:

- have been tested and know whether or not you have a particular gene variation called HLA-B*5701
- have or had liver problems, including hepatitis B or C virus infection
- have kidney problems
- have heart problems, smoke, or have diseases that increase your risk of heart disease such as high blood pressure, high cholesterol, or diabetes
- drink alcoholic beverages
- have any other medical condition
- are pregnant or plan to become pregnant. It is not known if TRIUMEQ will harm your unborn baby. Tell your healthcare provider if you become pregnant while taking TRIUMEQ.

Pregnancy Registry. There is a pregnancy registry for women who take antiviral medicines during pregnancy. The purpose of the registry is to collect information about the health of you and your baby. Talk to your healthcare provider about how you can take part in this registry.

- **are breastfeeding or plan to breastfeed. Do not breastfeed if you take TRIUMEQ.** You should not breastfeed because of the risk of passing HIV-1 to your baby. It is not known if abacavir or dolutegravir passes into your breast milk. Lamivudine can pass into your breast milk and may harm your baby. Talk to your healthcare provider about the best way to feed your baby.

Tell your healthcare provider about all the medicines you take, including prescription and over-the-counter medicines, vitamins, and herbal supplements. TRIUMEQ may affect the way other medicines work, and other medicines may affect how TRIUMEQ works.

You should not take TRIUMEQ if you also take:

- abacavir (EPZICOM, TRIZIVIR, or ZIAGEN)
- lamivudine (COMBIVIR[®], EPIVIR, EPIVIR-HBV[®], EPZICOM, or TRIZIVIR)
- emtricitabine (EMTRIVA[®], ATRIPLA[®], COMPLERA[®], STRIBILD[®], TRUVADA[®])

Tell your healthcare provider if you take:

- antacids, laxatives, or other medicines that contain aluminum, magnesium, sucralfate (CARAFATE[®]), or buffered medicines. TRIUMEQ should be taken at least 2 hours before or 6 hours after you take these medicines.
- anti-seizure medicines:
 - oxcarbazepine (TRILEPTAL[®])
 - phenytoin (DILANTIN[®], DILANTIN[®]-125, PHENYTEK[®])
 - phenobarbital
 - carbamazepine (CARBATROL[®], EQUETRO[®], TEGRETOL[®], TEGRETOL[®]-XR, TERIL[®], EPITOL[®])
- any other medicine to treat HIV-1
- iron or calcium supplements taken by mouth. Supplements containing calcium or iron may be taken at the same time with TRIUMEQ if taken with food. Otherwise, TRIUMEQ should be taken at least 2 hours before or 6 hours after you take these medicines.
- medicines used to treat hepatitis virus infections, such as interferon or ribavirin
- a medicine that contains metformin
- methadone
- rifampin (RIFATER[®], RIFAMATE[®], RIMACTANE[®], RIFADIN[®])
- St. John's wort (*Hypericum perforatum*)

Know the medicines you take. Keep a list of your medicines with you to show to your healthcare provider and pharmacist when you get a new medicine.

Ask your healthcare provider or pharmacist if you are not sure if you take one of the medicines listed above.

How should I take TRIUMEQ?

- **Take TRIUMEQ exactly as your healthcare provider tells you.**
- Do not change your dose or stop taking TRIUMEQ without talking with your healthcare provider.
- Stay under the care of a healthcare provider while taking TRIUMEQ.
- You can take TRIUMEQ with or without food.
- If you miss a dose of TRIUMEQ, take it as soon as you remember. If it is within 4 hours of your next dose, skip the missed dose and take the next dose at your regular time. Do not take 2 doses at the same time. If you are not sure about your dosing, call your healthcare provider.
- Do not run out of TRIUMEQ. The virus in your blood may become resistant to other HIV-1 medicines if TRIUMEQ is stopped for even a short time. When your supply starts to run low, get more from your healthcare provider or pharmacy.
- If you take too much TRIUMEQ, call your healthcare provider or go to the nearest hospital emergency room right away.

What are the possible side effects of TRIUMEQ?

TRIUMEQ can cause serious side effects including:

- **See “What is the most important information I should know about TRIUMEQ?”**
- **Changes in liver tests.** People with a history of hepatitis B or C virus may have an increased risk of developing new or worsening changes in certain liver tests during treatment with TRIUMEQ. Your healthcare provider may do tests to check your liver function before and during treatment with TRIUMEQ.
- **Changes in your immune system (Immune Reconstitution Syndrome)** can happen when you start taking HIV-1 medicines. Your immune system may get stronger and begin to fight infections that have been hidden in your body for a long time. Tell your healthcare provider right away if you start having new symptoms after starting your HIV-1 medicine.
- **Changes in body fat (fat redistribution)** can happen in people who take HIV-1 medicines. These changes may include increased amount of fat in the upper back and neck (“buffalo hump”), breast, and around the middle of your body (trunk). Loss of fat from the legs, arms, and face may also happen. The exact cause and long-term health effects of these problems are not known.

- **Heart attack (myocardial infarction).** Some HIV medicines including TRIUMEQ may increase your risk of heart attack.

The most common side effects of TRIUMEQ include:

- trouble sleeping
- headache
- tiredness

Tell your healthcare provider if you have any side effect that bothers you or that does not go away.

These are not all the possible side effects of TRIUMEQ. For more information, ask your healthcare provider or pharmacist.

Call your doctor for medical advice about side effects. You may report side effects to FDA at 1-800-FDA-1088.

How should I store TRIUMEQ?

- Store TRIUMEQ at room temperature between 68°F to 77°F (20°C to 25°C).
- Store TRIUMEQ in the original bottle.
- Keep the bottle of TRIUMEQ tightly closed and protect from moisture.
- The bottle of TRIUMEQ contains a desiccant packet to help keep your medicine dry (protect it from moisture). Keep the desiccant packet in the bottle. Do not remove the desiccant packet.

Keep TRIUMEQ and all medicines out of the reach of children.

General information about the safe and effective use of TRIUMEQ

Medicines are sometimes prescribed for purposes other than those listed in a Medication Guide. Do not use TRIUMEQ for a condition for which it was not prescribed. Do not give TRIUMEQ to other people, even if they have the same symptoms that you have. It may harm them.

This Medication Guide summarizes the most important information about TRIUMEQ. If you would like more information, talk with your healthcare provider. You can ask your healthcare provider or pharmacist for information about TRIUMEQ that is written for health professionals.

For more information go to www.TRIUMEQ.com or call 1-877-844-8872.

What are the ingredients in TRIUMEQ?

Active ingredients: abacavir, dolutegravir, and lamivudine

Inactive ingredients: D-mannitol, magnesium stearate, microcrystalline cellulose, povidone, and sodium starch glycolate. The tablet film-coating contains iron oxide

black, iron oxide red, macrogol/PEG, polyvinyl alcohol–part hydrolyzed, talc, and titanium oxide.

This Medication Guide has been approved by the U.S. Food and Drug Administration.

Manufactured for:



ViiV Healthcare

Research Triangle Park, NC 27709

by:



GlaxoSmithKline

Research Triangle Park, NC 27709

Lamivudine is manufactured under agreement from

Shire Pharmaceuticals Group plc

Basingstoke, UK

COMBIVIR, EPIVIR, EPZICOM, TIVICAY, TRIUMEQ, TRIZIVIR, and ZIAGEN are registered trademarks of the ViiV Healthcare group of companies.

EPIVIR-HBV is a registered trademark of the GSK group of companies.

The other brands listed are trademarks of their respective owners and are not trademarks of the ViiV Healthcare group of companies. The makers of these brands are not affiliated with and do not endorse the ViiV Healthcare group of companies or its products.

©2014year, the ViiV Healthcare group of companies. All rights reserved.

Issued: August 2014

TRM: XMG

(Front of card)

WARNING CARD
TRIUMEQ® (abacavir, dolutegravir, and lamivudine) Tablets

Patients taking TRIUMEQ may have a serious allergic reaction (hypersensitivity reaction) that can cause death. If you get a symptom from 2 or more of the following groups while taking TRIUMEQ, call your doctor right away to determine if you should stop taking this medicine.

	Symptom(s)
Group 1	Fever
Group 2	Rash
Group 3	Nausea, vomiting, diarrhea, or abdominal (stomach area) pain
Group 4	Generally ill feeling, extreme tiredness, or achiness
Group 5	Shortness of breath, cough, or sore throat

Always carry this Warning Card with you to help recognize symptoms of this allergic reaction.

(Back of Card)

WARNING CARD
TRIUMEQ® (abacavir, dolutegravir, and lamivudine) Tablets

If you must stop treatment with TRIUMEQ because you have had an allergic reaction to abacavir, **NEVER** take TRIUMEQ or any other abacavir-containing medicine (ZIAGEN®, EPZICOM®, TRIZIVIR®) again. If you take TRIUMEQ or another abacavir-containing medicine again after you have had an allergic reaction, **WITHIN HOURS** you may get **life-threatening symptoms** that may include **very low blood pressure** or **death**.

Please read the Medication Guide for additional information on TRIUMEQ.

August 2014

TRM:1WC

PRODUCT MONOGRAPH

PrTRUVADA[®]

(emtricitabine/tenofovir disoproxil fumarate) tablets

(200 mg/300 mg)

Antiretroviral Agent

Gilead Sciences, Inc.
Foster City, CA 94404
USA

Date of Revision: July 5, 2018

Gilead Sciences Canada, Inc.
Mississauga L5N 2W3
Canada

www.gilead.ca

Submission Control No.: 215258

TABLE OF CONTENTS

PART I. HEALTH PROFESSIONAL INFORMATION	3
SUMMARY PRODUCT INFORMATION	3
INDICATIONS AND CLINICAL USE	3
CONTRAINDICATIONS	5
WARNINGS AND PRECAUTIONS.....	6
ADVERSE REACTIONS.....	15
DRUG INTERACTIONS.....	24
DOSAGE AND ADMINISTRATION.....	36
OVERDOSAGE	38
ACTION AND CLINICAL PHARMACOLOGY	39
STORAGE AND STABILITY.....	41
SPECIAL HANDLING INSTRUCTIONS	41
DOSAGE FORMS, COMPOSITION AND PACKAGING	41
PART II. SCIENTIFIC INFORMATION	43
PHARMACEUTICAL INFORMATION.....	43
CLINICAL TRIALS.....	44
VIROLOGY (MICROBIOLOGY).....	54
NON-CLINICAL TOXICOLOGY.....	58
REFERENCES	60
PART III. CONSUMER INFORMATION	61

PART I. HEALTH PROFESSIONAL INFORMATION

SUMMARY PRODUCT INFORMATION

Route of Administration	Dosage Form / Strength	Clinically Relevant Nonmedicinal Ingredients
Oral	Tablet emtricitabine 200 mg/ tenofovir disoproxil fumarate 300 mg	lactose monohydrate, pregelatinized starch (gluten free)

*For a complete listing, see **Dosage Forms, Composition and Packaging** section.*

TRUVADA[®] tablets are a fixed-dose combination containing emtricitabine (also known as EMTRIVA[®]) and tenofovir disoproxil fumarate (DF) (also known as VIREAD[®]).

INDICATIONS AND CLINICAL USE

Treatment of HIV-1 Infection

TRUVADA is indicated in combination with other antiretroviral agents (such as non-nucleoside reverse transcriptase inhibitors or protease inhibitors) for the treatment of HIV-1 infection in adults.

Additional important information regarding the use of TRUVADA for the treatment of HIV-1 infection:

- It is not recommended that TRUVADA be used as a component of a triple nucleoside regimen.
- TRUVADA should not be coadministered with ATRIPLA[®], COMPLERA[®], DESCOVY[®], EMTRIVA, GENVOYA[®], ODEFSEY[™], STRIBILD[®], VEMLIDY[™], or VIREAD or lamivudine-containing products (see **WARNINGS AND PRECAUTIONS**).
- In treatment-experienced patients, the use of TRUVADA should be guided by laboratory testing and treatment history (see **VIROLOGY**).

Pre-Exposure Prophylaxis (PrEP) of HIV-1 Infection

TRUVADA is indicated in combination with safer sex practices for PrEP to reduce the risk of sexually acquired HIV-1 infection in adults at high risk.

When considering TRUVADA for PrEP, the following factors may help to identify individuals at high risk:

- has partner(s) known to be HIV-1 infected, or

- engages in sexual activity within a high prevalence area or social network and one or more of the following:
 - inconsistent or no condom use
 - diagnosis of sexually transmitted infections
 - exchange of sex for commodities (such as money, food, shelter, or drugs)
 - use of illicit drugs or alcohol dependence
 - incarceration
 - partner(s) of unknown HIV-1 status with any of the factors listed above

When prescribing TRUVADA for PrEP, healthcare providers must:

- prescribe TRUVADA as part of a comprehensive prevention strategy because TRUVADA is not always effective in preventing the acquisition of HIV-1 infection (see **WARNINGS AND PRECAUTIONS**);
- counsel all uninfected individuals to strictly adhere to the recommended TRUVADA dosing schedule because the effectiveness of TRUVADA in reducing the risk of acquiring HIV-1 was strongly correlated with adherence as demonstrated by measurable drug levels in clinical trials (see **WARNINGS AND PRECAUTIONS**);
- confirm a negative HIV-1 test immediately prior to initiating TRUVADA for a PrEP indication. If clinical symptoms consistent with acute viral infection are present and recent (<1 month) exposures are suspected, delay starting PrEP for at least one month and reconfirm HIV-1 status or use a test approved by Health Canada as an aid in the diagnosis of HIV-1 infection, including acute or primary HIV-1 infection (see **WARNINGS AND PRECAUTIONS**); and
- screen for HIV-1 infection at least once every 3 months while taking TRUVADA for PrEP.

This indication is based on clinical trials in men who have sex with men (MSM) at high risk for HIV-1 infection and in heterosexual serodiscordant couples (see **CLINICAL TRIALS**). For more information on TRUVADA for PrEP, log onto www.truvada.ca.

Geriatrics (>65 years of age)

Clinical studies of TRUVADA, EMTRIVA or VIREAD did not include sufficient numbers of subjects aged 65 and over to determine whether they respond differently from younger subjects.

Pediatrics (<18 years of age)

Safety and effectiveness in pediatric patients have not been established.

CONTRAINDICATIONS

TRUVADA is contraindicated in patients with previously demonstrated hypersensitivity to any of the components of the product. For a complete listing, see the **DOSAGE FORMS, COMPOSITION AND PACKAGING** section of the Product Monograph.

TRUVADA is contraindicated for use as PrEP in individuals with unknown or positive HIV-1 status.

WARNINGS AND PRECAUTIONS

Serious Warnings and Precautions

- **Lactic Acidosis and Severe Hepatomegaly with Steatosis**

Lactic acidosis and severe hepatomegaly with steatosis, including fatal cases, have been reported with the use of nucleoside analogs, including tenofovir DF (VIREAD), a component of TRUVADA, alone or in combination with other antiretrovirals (see **WARNINGS AND PRECAUTIONS**).

- **Post-Treatment Exacerbation of Hepatitis B**

TRUVADA is not approved for the treatment of chronic hepatitis B virus (HBV) infection and the safety and efficacy of TRUVADA have not been established in patients co-infected with HBV and HIV. Severe acute exacerbations of hepatitis B have been reported in patients who are co-infected with HBV and HIV and have discontinued TRUVADA. Hepatic function should be monitored closely with both clinical and laboratory follow-up for at least several months in patients who are infected with HBV and discontinue TRUVADA. If appropriate, initiation of anti-hepatitis B therapy may be warranted (see **WARNINGS AND PRECAUTIONS**).

- **Nephrotoxicity**

Renal impairment, including cases of acute renal failure and Fanconi syndrome (renal tubular injury with severe hypophosphatemia) has been reported with the use of TRUVADA during clinical practice (see **WARNINGS AND PRECAUTIONS**).

- **Risk of Drug Resistance with Use of TRUVADA for Pre-Exposure Prophylaxis (PrEP) in Undiagnosed Early HIV-1 Infection**

TRUVADA used for a PrEP indication must only be prescribed to individuals confirmed to be HIV-negative immediately prior to initial use and periodically (at least every 3 months) during use. Drug-resistant HIV-1 variants have been identified with the use of TRUVADA for a PrEP indication following undetected acute HIV-1 infection. Do not initiate TRUVADA for a PrEP indication if signs or symptoms of acute HIV infection are present unless negative infection status is confirmed (see **WARNINGS AND PRECAUTIONS**).

General

TRUVADA should be used in the treatment of HIV-1 infected patients only in combination with other antiretroviral agents.

TRUVADA is a fixed-dose combination of emtricitabine and tenofovir DF. TRUVADA should not be coadministered with other products containing tenofovir DF or emtricitabine (ATRIPLA, COMPLERA, DESCOVY, EMTRIVA, GENVOYA, ODEFSEY, STRIBILD, or VIREAD), or with medicinal products containing tenofovir alafenamide (DESCOVY, GENVOYA, ODEFSEY, and VEMLIDY). Due to similarities between emtricitabine and lamivudine, TRUVADA should not be coadministered with other drugs containing lamivudine (Combivir[®], 3TC[®], Heptovir[®], Kivexa[®], Triumeq[®], or Trizivir[®]).

TRUVADA should not be administered with adefovir dipivoxil (HEPSERA[®]).

Clinical studies in HIV-infected patients have demonstrated that certain regimens that only contain three nucleoside reverse transcriptase inhibitors (NRTI) are generally less effective than triple drug regimens containing two NRTIs in combination with either a non-nucleoside reverse transcriptase inhibitor or a HIV-1 protease inhibitor. In particular, early virological failure and high rates of resistance mutations have been reported. Triple nucleoside regimens should therefore be used with caution. Patients on a therapy utilizing a triple nucleoside-only regimen should be carefully monitored and considered for treatment modification.

Carcinogenesis, Mutagenesis, Impairment of Fertility

Emtricitabine: In long-term oral carcinogenicity studies of emtricitabine, no drug-related increase in tumor incidence was found in mice at doses up to 750 mg/kg/day (26 times the human systemic exposure at the therapeutic dose of 200 mg/day) or in rats at doses up to 600 mg/kg/day (31 times the human systemic exposure at the therapeutic dose).

Emtricitabine was not genotoxic in the reverse mutation bacterial test (Ames test), mouse lymphoma or mouse micronucleus assays.

Emtricitabine did not affect fertility in male rats at approximately 140-fold or in male and female mice at approximately 60-fold higher exposures (AUC) than in humans given the recommended 200 mg daily dose. Fertility was normal in the offspring of mice exposed daily from before birth (in utero) through sexual maturity at daily exposures (AUC) of approximately 60-fold higher than human exposures at the recommended 200 mg daily dose.

Tenofovir DF: Tenofovir DF did not show any carcinogenic potential in a long-term oral carcinogenicity study in rats. A long-term oral carcinogenicity study in mice showed a low incidence of duodenal tumors, considered likely related to high local concentrations in the gastrointestinal tract at the high dose of 600 mg/kg/day. Liver adenomas were also seen at the high dose in female mice. The mechanism of tumor formation in mice and potential relevance for humans are uncertain.

Tenofovir DF was mutagenic in the in vitro mouse lymphoma assay and negative in an in vitro bacterial mutagenicity test (Ames test). In an in vivo mouse micronucleus assay, tenofovir DF was negative at doses up to 2000 mg/kg when administered orally to male mice.

There were no effects on fertility, mating performance or early embryonic development when tenofovir DF was administered at 600 mg/kg/day to male rats for 28 days prior to mating and to female rats for 15 days prior to mating through day seven of gestation. There was, however, an alteration of the estrous cycle in female rats. A dose of 600 mg/kg/day is equivalent to 19 times the human dose based on body surface area comparisons.

Drug Interactions

Use with Certain HCV Regimens

Tenofovir exposure is increased when TRUVADA is coadministered with HARVONI[®] (ledipasvir/sofosbuvir), EPCLUSA[®] (sofosbuvir/velpatasvir), or VOSEVI[™] (sofosbuvir/velpatasvir/voxilaprevir). Patients receiving TRUVADA concomitantly with HARVONI, EPCLUSA or VOSEVI, particularly those at increased risk for renal dysfunction, should be monitored for tenofovir DF-associated adverse reactions (see **DRUG INTERACTIONS**).

Use with Didanosine

Pharmacokinetic studies have shown that coadministration of didanosine and tenofovir DF results in 40-60% increase in C_{max} and AUC of didanosine (see Table 8). The mechanism of this interaction is unknown. Increases in didanosine concentrations of this magnitude could potentiate didanosine-associated adverse events, including pancreatitis, lactic acidosis, and neuropathy. In addition, suppression of CD4 counts has been observed in patients receiving tenofovir DF with didanosine at a dose of 400 mg daily (see **DRUG INTERACTIONS**).

Endocrine and Metabolism

Serum Lipids and Blood Glucose

Serum lipid and blood glucose levels may increase during antiretroviral therapy. Disease control and life style changes may also be contributing factors. Consideration should be given to the measurement of serum lipids and blood glucose. Lipid disorders and blood glucose elevations should be managed as clinically appropriate.

Hepatic/Biliary/Pancreatic

Lactic Acidosis/Severe Hepatomegaly with Steatosis

Lactic acidosis and severe hepatomegaly with steatosis, including fatal cases, have been reported with the use of antiretroviral nucleoside analogs, including tenofovir DF, a component of TRUVADA, alone or in combination with other antiretrovirals in the treatment of HIV infection. A majority of these cases have been in women. Obesity and prolonged nucleoside exposure may be risk factors. Particular caution should be exercised when administering nucleoside analogs to any patient with known risk factors for liver disease; however, cases have also been reported in patients with no known risk factors. Treatment with TRUVADA should be suspended in any patient who develops clinical or laboratory findings suggestive of lactic acidosis or pronounced hepatotoxicity (which may include hepatomegaly and steatosis even in the absence of marked transaminase elevations).

Hepatic Impairment

Tenofovir and tenofovir disoproxil are not metabolized by liver enzymes. Clinically relevant pharmacokinetic changes in patients with hepatic impairment are not observed. Therefore, no dose adjustment is required in patients with hepatic impairment. Emtricitabine has not been evaluated in patients with hepatic impairment; however, emtricitabine has not been shown to be metabolized by liver enzymes, so the impact of liver impairment is likely to be limited. The safety and efficacy of TRUVADA has not been established or specifically studied in patients with underlying liver disorders.

Patients with chronic hepatitis B or C and treated with antiretroviral therapy are at increased risk for severe and potentially fatal hepatic adverse events. In case of concomitant antiviral therapy for hepatitis B or C, please refer also to the relevant product information for these medicinal products.

Hepatitis B Virus Infection

It is recommended that all patients be tested for the presence of hepatitis B virus (HBV) before initiating TRUVADA. TRUVADA is not approved for the treatment of chronic HBV infection and the safety and efficacy of TRUVADA have not been established in patients infected with HBV. Severe acute exacerbations of hepatitis B have been reported in patients who are co-infected with HBV and HIV after the discontinuation of TRUVADA. In some patients infected with HBV and treated with EMTRIVA, the exacerbations of hepatitis B were associated with liver decompensation and liver failure. Hepatic function should be closely monitored with both clinical and laboratory follow up for at least several months in patients who are infected with HBV and discontinue TRUVADA. If appropriate, initiation of anti-hepatitis B therapy may be warranted. In patients with advanced liver disease or cirrhosis, post-treatment exacerbation of hepatitis may lead to hepatic decompensation. Therefore, in these patients, discontinuation of treatment without initiation of alternative anti-hepatitis B therapy is not recommended.

Pancreatitis

Pancreatitis has occurred during therapy with combination regimens that included tenofovir DF (VIREAD). Caution should be used when administering nucleoside analogues (including TRUVADA) to patients with a history of pancreatitis or risk factors for the development of pancreatitis. Therapy should be suspended in patients with suspected pancreatitis.

Immune

Immune Reconstitution Inflammatory Syndrome

Immune reconstitution inflammatory syndrome has been reported in HIV-1 infected patients treated with combination antiretroviral therapy, including the components of TRUVADA. During the initial phase of combination antiretroviral treatment, patients responding to antiretroviral therapy may develop an inflammatory response to indolent or residual opportunistic infections (such as *Mycobacterium avium* infections, cytomegalovirus,

Pneumocystis jiroveci pneumonia (PCP), and tuberculosis), which may necessitate further evaluation and treatment.

Autoimmune disorders (such as Graves' disease, polymyositis and Guillain-Barré syndrome) have also been reported to occur in the setting of immune reconstitution; however, the reported time to onset is more variable, and these events can occur many months after initiation of treatment.

Musculoskeletal

Bone Effects

Bone Mineral Density

In a clinical trial in treatment-naïve HIV-1 infected adults through 144 weeks, decreases from baseline in bone mineral density (BMD) were seen at the lumbar spine and hip in both tenofovir DF and stavudine treatment arms of the study; significantly greater decreases were seen in the lumbar spine measurement in the tenofovir DF group relative to the stavudine group. Clinically relevant fractures were reported in both treatment groups. Increases in biochemical markers of bone metabolism (serum bone-specific alkaline phosphatase, serum osteocalcin, serum C-telopeptide, and urinary N-telopeptide) were observed, suggesting increased bone turnover. Except for bone specific alkaline phosphatase, these changes resulted in values that remained within the normal range. These decreases in BMD and increases in biochemical markers of bone metabolism were also seen in the PrEP trials in HIV-1 uninfected individuals. The effects of tenofovir DF-associated changes in BMD and biochemical markers on long-term bone health and future fracture risk are unknown.

Assessment of BMD should be considered for patients who have a history of pathologic bone fracture or are at risk for osteopenia or osteoporosis. Although the effect of supplementation with calcium and vitamin D was not studied, such supplementation may be beneficial. If bone abnormalities are suspected then appropriate consultation should be obtained.

Mineralization Defects

Cases of hypophosphatemic osteomalacia associated with proximal renal tubulopathy, manifested as bone pain or pain in the extremities and which may contribute to fractures, have been reported in association with the use of tenofovir DF (see **ADVERSE REACTIONS, Post Market Adverse Drug Reactions**). Arthralgias and muscle pain or weakness have also been reported in cases of proximal renal tubulopathy. Hypophosphatemia and osteomalacia secondary to proximal renal tubulopathy should be considered in patients at risk of renal dysfunction who present with persistent or worsening bone or muscle symptoms while receiving products containing tenofovir DF. Serum phosphate should be monitored in these patients.

Renal

Nephrotoxicity

Emtricitabine and tenofovir are principally eliminated by the kidney. Renal impairment, including cases of acute renal failure and Fanconi syndrome (renal tubular injury with severe hypophosphatemia) has been reported in association with the use of tenofovir DF in clinical practice. The majority of these cases occurred in patients with underlying systemic or renal disease, or in patients taking nephrotoxic agents; however, some cases occurred in patients without identified risk factors. Persistent or worsening bone pain, pain in extremities, fractures and/or muscular pain or weakness may be manifestations of proximal renal tubulopathy and should prompt an evaluation of renal function in at-risk patients. It is recommended that creatinine clearance be calculated in all patients prior to initiating therapy and as clinically appropriate during therapy with TRUVADA. In patients at risk of renal dysfunction, including patients who have previously experienced renal events while receiving HEPSERA, it is recommended that calculated creatinine clearance, serum phosphorus, urine glucose, and urine protein be assessed prior to initiation of TRUVADA, and periodically during TRUVADA therapy (see **ADVERSE REACTIONS, Post Market Adverse Drug Reactions and DRUG INTERACTIONS**).

If serum phosphate is < 1.5 mg/dl (0.48 mmol/l) or creatinine clearance is decreased to < 50 ml/min in any patient receiving TRUVADA, renal function should be re-evaluated within one week, including measurements of blood glucose, blood potassium and urine glucose concentrations. Consideration should also be given to interrupting treatment with TRUVADA in patients with creatinine clearance decreased to < 50 ml/min or decreases in serum phosphate to < 1.0 mg/dl (0.32 mmol/l). Interrupting treatment with TRUVADA should also be considered in case of progressive decline of renal function when no other cause has been identified (see **ADVERSE REACTIONS**).

TRUVADA should be avoided with concurrent or recent use of a nephrotoxic agent [eg, cidofovir, acyclovir, valacyclovir, ganciclovir, valganciclovir, aminoglycosides, high-dose or multiple non-steroidal anti-inflammatory drugs (NSAIDs)]. Cases of acute renal failure after initiation of high dose or multiple NSAIDs have been reported in HIV-1 infected patients with risk factors for renal dysfunction who appeared stable on tenofovir DF. Some patients required hospitalization and renal replacement therapy. Alternatives to NSAIDs should be considered, if needed, in patients at risk for renal dysfunction (see **DRUG INTERACTIONS**).

Renal Impairment

Treatment of HIV-1 infection

Dosing interval adjustment of TRUVADA and close monitoring of renal function are recommended in all patients with creatinine clearance 30-49 mL/min. No safety and efficacy data are available in patients with renal dysfunction who received TRUVADA using these guidelines, and so the potential benefit of TRUVADA should be assessed against the potential risk of renal toxicity. TRUVADA should not be administered to patients with

creatinine clearance <30 mL/min or patients requiring hemodialysis (see **DOSAGE AND ADMINISTRATION**).

Pre-exposure Prophylaxis of HIV-1 infection

TRUVADA for a PrEP indication should not be used in HIV-1 uninfected individuals with creatinine clearance below 60 mL/min.

If a decrease in creatinine clearance is observed in uninfected individuals while using TRUVADA for PrEP, evaluate potential causes and re-assess potential risks and benefits of continued use (see **DOSAGE AND ADMINISTRATION**).

Special Populations

Pregnant Women

Antiretroviral Pregnancy Registry: To monitor fetal outcomes of pregnant women exposed to ART (antiretroviral therapy) including TRUVADA, an Antiretroviral Pregnancy Registry has been established. Healthcare providers are encouraged to register patients by calling 800-258-4263.

TRUVADA has been evaluated in a limited number of women during pregnancy and postpartum. Available human and animal data suggest that TRUVADA does not increase the risk of major birth defects overall compared to the background rate. There are, however, no adequate and well-controlled studies in pregnant women. Because animal reproduction studies are not always predictive of human response, TRUVADA should be used in pregnant women only if the potential benefits outweigh the potential risks to the fetus. If an uninfected individual becomes pregnant while taking TRUVADA for a PrEP indication, careful consideration should be given to whether use of TRUVADA should be continued, taking into account the potential increased risk of HIV-1 infection during pregnancy.

As of July 2015, the APR has received prospective reports of 1984 and 2608 exposures to emtricitabine- and tenofovir-containing regimens, respectively in the first trimester; and 949 and 1258 exposures, respectively, in second/third trimester, respectively. Birth defects occurred in 47 of 1984 (2.4%) live births for emtricitabine-containing regimens and 60 of 2608 (2.3%) live births for tenofovir-containing regimens (first trimester exposure); and 20 of 949 (2.1%) live births for emtricitabine-containing regimens and 26 of 1258 (2.1%) live births for tenofovir containing regimens (second/third trimester exposure). Among pregnant women in the U.S. reference population, the background rate of birth defects is 2.7%. There was no association between emtricitabine or tenofovir and overall birth defects observed in the APR.

Emtricitabine: The incidence of fetal variations and malformations was not increased in embryo-fetal toxicity studies performed with emtricitabine in mice at exposures (AUC) approximately 60-fold higher and in rabbits at approximately 120-fold higher than human exposures at the recommended daily dose.

Tenofovir DF: Reproduction studies have been performed in rats and rabbits at doses up to 14 and 19 times the human dose based on body surface area comparisons and revealed no evidence of impaired fertility or harm to the fetus due to tenofovir. Reduced pup body weights, survival and delay in sexual maturation was observed in a peri- and postnatal toxicity study in rats at the maternally toxic doses of 450 and 600 mg/kg (approximately 14 and 19 times the human dose based on body surface area comparisons).

Nursing Women

HIV-infected mothers should not breastfeed their infants to avoid risking postnatal transmission of HIV to the infant.

In humans, samples of breast milk obtained from five HIV-1 infected mothers show that tenofovir is secreted in human milk at low levels (estimated neonatal concentrations 128 to 266 times lower than the tenofovir IC₅₀). Tenofovir-associated risks, including the risk of developing viral resistance to tenofovir, in infants breastfed by mothers being treated with tenofovir DF are unknown.

Samples of breast milk obtained from five HIV-1 infected mothers show that emtricitabine is secreted in human milk at estimated neonatal concentrations 3 to 12 times higher than the emtricitabine IC₅₀ but 3 to 12 times lower than the C_{min} achieved from oral administration of emtricitabine. Breast-feeding infants whose mothers are being treated with emtricitabine may be at risk for developing viral resistance to emtricitabine. Other emtricitabine-associated risks in infants breastfed by mothers being treated with emtricitabine are unknown.

Because of both the potential for HIV transmission and the potential for serious adverse reactions in nursing infants, **mothers should be instructed not to breastfeed if they are receiving TRUVADA**, whether they are taking TRUVADA for treatment or to reduce the risk of acquiring HIV-1.

Pediatrics (<18 years of age)

Safety and effectiveness in pediatric patients have not been established.

Geriatrics (>65 years of age)

Clinical studies of EMTRIVA or VIREAD did not include sufficient numbers of subjects aged 65 and over to determine whether they respond differently than younger subjects. In general, dose selection for the elderly patient should be cautious, keeping in mind the greater frequency of decreased hepatic, renal, or cardiac function, and of concomitant disease or other drug therapy.

PrEP to Reduce the Risk of Acquiring HIV-1 Infection

Comprehensive HIV-1 Infection Prevention Strategy

Use TRUVADA for PrEP only as part of a comprehensive prevention strategy that includes other prevention measures, such as safer sex practices, because TRUVADA is not always effective in preventing the acquisition of HIV-1 (see **CLINICAL TRIALS**).

- Counsel uninfected individuals about safer sex practices that include consistent and correct use of condoms, knowledge of their HIV-1 status and that of their partner(s), and regular testing for other sexually transmitted infections that can facilitate HIV-1 transmission (such as syphilis and gonorrhea).
- Inform uninfected individuals about and support their efforts in reducing sexual risk behavior.

Risk of Resistance

Use TRUVADA to reduce the risk of acquiring HIV-1 only in individuals confirmed to be HIV-negative prior to initiating PrEP and re-confirmed routinely while taking PrEP. HIV-1 resistance substitutions may emerge in individuals with undetected HIV-1 infection who are taking only TRUVADA, **because TRUVADA alone does not constitute a complete treatment regimen for HIV-1 treatment**; therefore, care should be taken to minimize drug exposure in HIV-infected individuals (see **VIROLOGY: Resistance**).

- Many HIV-1 tests, such as rapid tests, detect anti-HIV antibodies and may not identify HIV-1 during the acute stage of infection. Prior to initiating TRUVADA for a PrEP indication, evaluate seronegative individuals for current or recent signs or symptoms consistent with acute viral infections (e.g., fever, fatigue, myalgia, skin rash, etc.) and ask about potential exposure events (e.g., unprotected, or condom broke during sex with an HIV-1 infected partner) that may have occurred within the last month.
- If clinical symptoms consistent with acute viral infection are present and recent (<1 month) exposures are suspected, delay starting PrEP for at least one month and reconfirm HIV-1 negative status or use a test approved by Health Canada as an aid in the diagnosis of HIV-1 infection, including acute or primary HIV-1 infection.
- While using TRUVADA for a PrEP indication, HIV-1 screening tests should be repeated at least every 3 months. If symptoms consistent with acute HIV-1 infection develop following a potential exposure event, PrEP should be discontinued until negative infection status is confirmed using a test approved by Health Canada as an aid in the diagnosis of HIV-1, including acute or primary HIV-1 infection.

Counsel uninfected individuals to strictly adhere to the recommended TRUVADA dosing schedule. The effectiveness of TRUVADA in reducing the risk of acquiring HIV-1 is strongly correlated with adherence as demonstrated by measurable drug levels in clinical trials (see CLINICAL TRIALS). For more information on TRUVADA for PrEP,

log onto www.truvada.ca.

ADVERSE REACTIONS

Clinical Trial Adverse Drug Reactions

Because clinical trials are conducted under very specific conditions the adverse reaction rates observed in the clinical trials may not reflect the rates observed in practice and should not be compared to the rates in the clinical trials of another drug. Adverse drug reaction information from clinical trials is useful for identifying drug-related adverse events and for approximating rates.

Adverse Reactions from Clinical Trials Experience in HIV-1 Infected Subjects

TRUVADA: Four hundred and forty-seven HIV-1 infected patients have received combination therapy with EMTRIVA or VIREAD with either a non-nucleoside reverse transcriptase inhibitor or protease inhibitor for 48 weeks in ongoing clinical studies. Study 934 - Treatment Emergent Adverse Events: Assessment of adverse reactions is based on data from Study 934 in which 511 antiretroviral-naïve patients received either EMTRIVA + VIREAD administered in combination with efavirenz (N=257) or Combivir[®] (lamivudine/zidovudine) administered in combination with efavirenz (N=254). Adverse events observed in this study were generally consistent with those seen in other studies in treatment experienced or treatment-naïve patients (Table 1).

Table 1. Selected Treatment-Emergent Adverse Events (Grades 2–4) Reported in ≥3% in Any Treatment Group in Study 934 (0–48 Weeks)

	EMTRIVA+VIREAD+EFV	AZT/3TC+EFV
	N=257	N=254
Blood and Lymphatic System Disorders		
Anemia	<1%	5%
Gastrointestinal Disorder		
Diarrhea	7%	4%
Nausea	8%	6%
Vomiting	1%	4%
General Disorders and Administration Site Condition		
Fatigue	7%	6%
Infections and Infestations		
Sinusitis	4%	2%
Upper respiratory tract infections	3%	3%
Nasopharyngitis	3%	1%
Nervous System Disorders		
Somnolence	3%	2%
Headache	5%	4%
Dizziness	8%	7%
Psychiatric Disorders		
Depression	4%	7%
Insomnia	4%	5%
Abnormal dreams	4%	3%
Skin and Subcutaneous Tissue Disorders		
Rash	5%	4%

Patients who received treatment up to 144 weeks in Study 934 reported adverse events similar in nature and severity to those reported in the first 48 weeks.

Through 48 weeks, 7 patients in the EMTRIVA + VIREAD group and 5 patients in the lamivudine/zidovudine group experienced a new CDC Class C event (10 and 6 patients, respectively, through 144 weeks). Renal safety assessed by laboratory abnormalities was similar in the two groups and no patient discontinued study drug due to renal events. At

Weeks 48 and 144, total limb fat (as measured by dual-energy x-ray absorptiometry) was significantly less in a subgroup of patients in the lamivudine/zidovudine group compared to the tenofovir/emtricitabine subgroup (see Table 2).

Table 2. Study 934 Total Limb Fat at Week 48 and 144 (Dual-Energy X-Ray Absorptiometry)

	EMTRIVA + VIREAD + EFV	AZT/3TC +EFV
Week 48¹	N=51	N=49
Total Limb Fat (kg) (Mean ± S.D.)	8.9 ±5.4	6.9 ±3.9
Week 144²	N=145	N=124
Total Limb Fat (kg) (Mean ± S.D.)	9.2 ±5.4	6.5 ±4.3

¹P=0.03 for the comparison between arms

²P<0.001 for the comparison between arms

Laboratory Abnormalities: Laboratory Abnormalities observed in this study were generally consistent with those seen in other studies (Table 3).

Table 3. Grade 3/4 Laboratory Abnormalities Reported in ≥1% in Any Treatment Group in Study 934 (0–48 Weeks)

	EMTRIVA+VIREAD+EFV N=257	AZT/3TC+EFV N=254
Any ≥ Grade 3 Laboratory Abnormality	25%	22%
Fasting Cholesterol (>240 mg/dL)	15%	17%
Creatine Kinase (M: >990 U/L) (F: >845 U/L)	7%	6%
Serum Amylase (>175U/L)	7%	3%
Alkaline Phosphatase (>550 U/L)	1%	0%
AST (M: >180 U/L) (F: >170 U/L)	3%	2%
ALT (M: >215 U/L) (F: >170 U/L)	2%	2%

	EMTRIVA+VIREAD+EFV N=257	AZT/3TC+EFV N=254
Hemoglobin (<8.0 mg/dL)	0%	3%
Hyperglycemia (>250 mg/dl)	1%	1%
Hematuria (>75 RBC/HPF)	2%	2%
Neutrophil (>750/mm ³)	3%	4%
Fasting Triglycerides (>750 mg/dL)	4%	2%

Laboratory abnormalities in patients who received treatment up to 144 weeks in Study 934 were consistent with those observed in the first 48 weeks of treatment.

In addition to the events described above for Study 934, other adverse events that occurred in at least 3-5% of patients receiving EMTRIVA or VIREAD with other antiretroviral agents in clinical trials include: anorexia, anxiety, arthralgia, asthenia, increased cough, depressive disorders, dyspepsia, fever, flatulence, myalgia, pain, abdominal pain, back pain, chest pain, paresthesia, peripheral neuropathy (including peripheral neuritis and neuropathy), pneumonia, rhinitis and rash event (including rash, pruritus, maculopapular rash, urticaria, vesiculobullous rash, pustular rash and allergic reaction), sweating and weight loss.

Skin discoloration has been reported with higher frequency among EMTRIVA treated patients. Skin discoloration, mainly manifested by hyperpigmentation on the palms and/or soles was generally mild and asymptomatic and of little clinical significance. The mechanism is unknown.

In addition to the laboratory abnormalities described above for Study 934, Grade 3/4 elevations of bilirubin (>2.5 x ULN), pancreatic amylase (>2.0 x ULN), serum glucose (<40 or >250 mg/dL), serum lipase (>2.0 x ULN), and urine glucose (≥3+) occurred in up to 3% of patients treated with EMTRIVA or VIREAD with other antiretroviral agents in clinical trials.

For more information, please consult the EMTRIVA and VIREAD Product Monographs.

In Study 903 through 144 weeks, decreases from baseline in bone mineral density (BMD) were seen at the lumbar spine and hip in both arms of the study. At Week 144, there was a significantly greater mean percentage decrease from baseline in BMD at the lumbar spine in patients in the tenofovir DF group compared with patients in the stavudine group (see Table 4). In both groups, the majority of the reduction in BMD occurred in the first 24–48 weeks of the study and this reduction was sustained through Week 144. Twenty-eight percent of tenofovir DF-treated patients vs. 21% of the stavudine-treated patients lost at least 5% of BMD at the spine or 7% of BMD at the hip. Clinically relevant fractures (excluding fingers and toes) were reported in 4 patients in the tenofovir DF group and 6 patients in the stavudine group. In addition, there were significant increases in biochemical markers of bone metabolism (serum bone-specific alkaline phosphatase, serum osteocalcin, serum C-

telo peptide, and urinary N-telo peptide) in the tenofovir DF group relative to the stavudine group, suggesting increased bone turnover. Serum parathyroid hormone levels and 1,25 Vitamin D levels were also higher in the tenofovir DF group. Except for bone specific alkaline phosphatase, these changes resulted in values that remained within the normal range. The effects of tenofovir DF-associated changes in BMD and biochemical markers on long-term bone health and future fracture risk are unknown.

Table 4 Changes in Bone Mineral Density Study 903

	Mean Percent Change (\pm SD) to Week 144 in BMD	
	VIREAD + 3TC+ EFV	d4T + 3TC +EFV
Lumbar Spine	-2.2% \pm 3.9	-1.0% \pm 4.6
Hip	-2.8% \pm 3.5	-2.4% \pm 4.5

Adverse Reactions from Clinical Trials Experience in HIV-1 Uninfected Adult Subjects (PrEP)

No new adverse reactions to TRUVADA were identified from two randomized placebo-controlled clinical trials (iPrEx, Partners PrEP) in which 2830 HIV-1 uninfected adults received TRUVADA once daily for pre-exposure prophylaxis. Subjects were followed for a median of 71 weeks and 87 weeks, respectively. These trials enrolled HIV-negative individuals ranging in age from 18 to 67 years. The iPrEx trial enrolled only men or transgender women of Hispanic/Latino (72%), White (18%), Black (9%) and Asian (5%) race. The Partners PrEP trial enrolled both men (61–64% across treatment groups) and women in Kenya and Uganda. Table 5 provides a list of all adverse events that occurred \geq 2% of subjects in any treatment group in the iPrEx and Partners PrEP trials.

Table 5 Selected Adverse Events (All Grades) Reported in $\geq 2\%$ of Uninfected individuals in Any Treatment Group in the iPrEx Trial and Partners PrEP Trial

	iPrEx Trial		Partners PrEP Trial	
	FTC/TDF N=1251	Placebo N=1248	FTC/TDF N=1579	Placebo N=1584
Gastrointestinal Disorder				
Diarrhea	7%	8%	2%	3%
Abdominal pain	4%	2%	- ^a	-
Infections and Infestations				
Pharyngitis	13%	16%	-	-
Urethritis	5%	7%	-	-
Urinary tract infection	2%	2%	5%	7%
Syphilis	6%	5%	-	-
Secondary syphilis	6%	4%	-	-
Anogenital warts	2%	3%	-	-
Musculoskeletal and Connective Tissue Disorders				
Back pain	5%	5%	-	-
Nervous System Disorders				
Headache	7%	6%	-	-
Psychiatric Disorders				
Depression	6%	7%	-	-
Anxiety	3%	3%	-	-
Reproductive System and Breast Disorders				
Genital ulceration	2%	2%	2%	2%
Investigations				
Weight decreased	3%	2%	-	-

a. Not reported or reported below 2%.

Laboratory Abnormalities: Table 6 provides a list of laboratory abnormalities observed in both PrEP trials. Six subjects in the TDF-containing arms of the Partners PrEP trial discontinued participation in the study due to an increase in blood creatinine compared with no discontinuations in the placebo group. One subject in the TRUVADA arm of the iPrEx trial discontinued from the study due to an increase in blood creatinine and another due to low phosphorus.

Table 6 Laboratory Abnormalities (Highest Toxicity Grade) Reported for Each Subject in the iPrEx Trial and Partners PrEP Trial

	Grade ^b	iPrEx Trial		Partners PrEP Trial	
		FTC/TDF N=1251	Placebo N=1248	FTC/TDF N=1579	Placebo N=1584
Creatinine	1 (1.1-1.3 X ULN)	27 (2%)	21 (2%)	18 (1%)	12 (<1%)
	2-4 (> 1.4 x ULN)	5 (<1%)	3 (<1%)	2 (<1%)	1 (<1%)
Phosphorus	1 (2.5 - <LLN mg/dL)	81 (7%)	110 (9%)	NR ^a	NR ^a
	2-4 (<2.0 mg/dL)	123 (10%)	101 (8%)	140 (9%)	136 (9%)
AST	1 (1.25-<2.5 x ULN)	175 (14%)	175 (14%)	20 (1%)	25 (2%)
	2-4 (> 2.6 x ULN)	57 (5%)	61 (5%)	10 (<1%)	4 (<1%)
ALT	1 (1.25-<2.5 x ULN)	178 (14%)	194 (16%)	21 (1%)	13 (<1%)
	2-4 (> 2.6 x ULN)	84 (7%)	82 (7%)	4 (<1%)	6 (<1%)
Hemoglobin	1 (8.5 - 10 mg/dL)	49 (4%)	62 (5%)	56 (4%)	39 (2%)
	2-4 (<9.4 mg/dL)	13 (1%)	19 (2%)	28 (2%)	39 (2%)
Neutrophils	1 (1000-1300/mm ³)	23 (2%)	25 (2%)	208 (13%)	163 (10%)
	2-4 (<750/mm ³)	7 (<1%)	7 (<1%)	73 (5%)	56 (3%)

- a. Grade 1 phosphorus was not reported for the Partners PrEP trial.
b. Grading is per DAIDS criteria.

In addition to the laboratory abnormalities described above, Grade 1 proteinuria (1+) occurred in 6% of subjects receiving TRUVADA in the iPrEx trial. Grade 2-3 proteinuria (2-4+) and glycosuria (3+) occurred in less than 1% of subjects treated with TRUVADA in the iPrEx trial and Partners PrEP trial.

In clinical trials of HIV-1 uninfected individuals, decreases in BMD were observed. In the iPrEx trial, a substudy of 503 subjects found mean changes from baseline in BMD ranging from -0.4% to -1.0% across total hip, spine, femoral neck, and trochanter in the TRUVADA group compared with the placebo group, which returned toward baseline after discontinuation of treatment. Thirteen percent of subjects receiving TRUVADA vs. 6% of subjects receiving placebo lost at least 5% of BMD at the spine during treatment. Bone fractures were reported in 1.7% of the TRUVADA group compared with 1.4% in the placebo group. No correlation between BMD and fractures was noted. The Partners PrEP trial found similar fracture rates between treatment and placebo groups (0.8% and 0.6%, respectively). No BMD evaluations were conducted during this trial (see **CLINICAL TRIALS**).

Post Market Adverse Drug Reactions

Emtricitabine: The following adverse experiences have been reported in post-marketing experience without regard to causality. Because these events are voluntarily reported from a population of unknown size, estimates of frequency cannot be made. These events have been considered possible adverse reactions due to a combination of their seriousness, frequency of reporting or potential causal relationship with treatment.

<i>Blood and lymphatic system disorders:</i>	Thrombocytopenia
<i>Gastrointestinal disorders:</i>	Pancreatitis
<i>General disorders and administrative site conditions:</i>	Pyrexia
<i>Metabolism and nutrition disorders:</i>	Lactic acidosis

Tenofovir DF: The following adverse reactions have been identified during post-approval use of VIREAD. Because these events have been reported voluntarily from a population of unknown size, estimates of frequency cannot be made. These events have been considered possible adverse reactions due to a combination of their seriousness, frequency of reporting or potential causal relationship with tenofovir DF.

<i>Immune system disorders:</i>	Allergic reaction (including angioedema)
<i>Metabolism and nutrition disorders:</i>	Lactic acidosis, hypokalemia, hypophosphatemia,
<i>Respiratory, thoracic and mediastinal disorders:</i>	Dyspnea
<i>Gastrointestinal disorders:</i>	Pancreatitis, increased amylase, abdominal pain
<i>Blood and lymphatic system disorders:</i>	Thrombocytopenia
<i>Hepatobiliary disorders:</i>	Hepatic steatosis, hepatitis, increased liver enzymes (most commonly AST, ALT, GGT)
<i>Skin and Subcutaneous Tissue Disorders:</i>	Rash
<i>Musculoskeletal and Connective Tissue Disorders:</i>	Rhabdomyolysis, osteomalacia (manifested as bone pain and infrequently contributing to fractures), muscular weakness, myopathy
<i>Renal and urinary disorders:</i>	Acute renal failure, renal failure, acute tubular necrosis, Fanconi syndrome, proximal renal tubulopathy, interstitial nephritis (including acute cases), nephrogenic diabetes insipidus, renal insufficiency, increased creatinine,

	proteinuria, polyuria
<i>General Disorders and Administration Site Conditions</i>	Asthenia

The following adverse reactions, listed under the body system headings above, may occur as a consequence of proximal renal tubulopathy: rhabdomyolysis, osteomalacia (manifested as bone pain and infrequently contributing to fractures), hypokalemia, muscular weakness, myopathy, hypophosphatemia.

There have been three post marketing reports of acute renal failure in patients on concomitant NSAIDS therapy where a relationship to tenofovir DF could not be excluded. These events mostly occurred in medically complex patients, where underlying disease processes confound interpretation.

Emtricitabine and Tenofovir DF: In HIV-infected patients with severe immune deficiency at the time of initiation of antiretroviral therapy an inflammatory reaction to infectious pathogens (active or inactive) may arise (see **WARNINGS AND PRECAUTIONS**).

In HIV infected patients coinfecting with HBV, clinical and laboratory evidence of exacerbations of hepatitis has occurred after discontinuation of treatment (see **WARNINGS AND PRECAUTIONS**).

DRUG INTERACTIONS

Overview

Drug interaction studies have been conducted with either TRUVADA, or the components of TRUVADA (emtricitabine and tenofovir DF) as individual agents and/or in combination.

The steady state pharmacokinetics of emtricitabine and tenofovir were unaffected when emtricitabine and tenofovir DF were administered together versus each agent dosed alone (see Table 9 and Table 10).

In vitro and clinical pharmacokinetic drug-drug interaction studies have shown that the potential for CYP450 mediated interactions involving emtricitabine and tenofovir with other medicinal products is low.

Drug-Drug Interactions

Established and Other Potentially Significant Drug Interactions

The drug interactions described are based on studies conducted with the individual agents of TRUVADA and/or in combination, or are potential drug interactions that may occur with TRUVADA.

Table 7. Established and Other Potentially Significant^a Drug Interactions

Concomitant Drug Class: Drug Name	Effect on Concentration ^b	Clinical Comment
Antiretroviral Agents:		
Didanosine	↑ didanosine	<p>Pharmacokinetic studies have shown that coadministration of didanosine and tenofovir DF results in 40-60% increase in C_{max} and AUC of didanosine (see Table 8). The mechanism of this interaction is unknown. Increases in didanosine concentrations of this magnitude could potentiate didanosine-associated adverse events, including pancreatitis, lactic acidosis, and neuropathy. In addition, suppression of CD4 counts has been observed in patients receiving tenofovir DF with didanosine at a dose of 400 mg daily.</p> <p>A reduced dose of Videx EC[®] (ddI-EC) is recommended when coadministered with TRUVADA. When coadministered with TRUVADA, the Videx EC[®] Product Monograph recommends a reduced dose of 250 mg ddI-EC for HIV infected adults with body weight ≥ 60 kg and creatinine clearance ≥ 60 mL/min. For patients with body weight < 60 kg, and creatinine clearance ≥ 60 mL/min, the recommended dose of ddI-EC is 200 mg. Data are not available to recommend a dose adjustment for patients with creatinine clearance < 60 mL/min or for the buffered tablet formulation of didanosine (Videx[®]).</p> <p>Caution should be used when coadministering reduced-dose didanosine, tenofovir, and an NNRTI in treatment-naïve patients</p>

Concomitant Drug Class: Drug Name	Effect on Concentration ^b	Clinical Comment
		with high viral loads at baseline since such use has been associated with reports of a high rate of virologic failure and emergence of resistance at an early stage. All patients receiving tenofovir DF and didanosine concomitantly should be closely monitored for didanosine-related adverse events and clinical response.
Atazanavir/ritonavir Darunavir/ritonavir Lopinavir/ritonavir	↑ tenofovir	Atazanavir/ritonavir, darunavir/ritonavir and lopinavir/ritonavir have been shown to increase tenofovir concentrations (see Table 11). The mechanism of this interaction is unknown. Higher tenofovir concentrations could potentiate tenofovir-associated adverse events, including renal disorders. Patients receiving atazanavir/ritonavir, darunavir/ritonavir or lopinavir/ritonavir and TRUVADA should be monitored for TRUVADA-associated adverse events.
Atazanavir	↓ atazanavir	Tenofovir decreases atazanavir concentrations (see Table 12). Although safety and efficacy data are limited, it is recommended that atazanavir, without ritonavir, should not be coadministered with TRUVADA. The recommended regimen is atazanavir 300 mg given with ritonavir 100 mg when used in combination with TRUVADA (all as a single daily dose with food).

Hepatitis C Virus Antiviral Agents:

Ledipasvir/sofosbuvir Sofosbuvir/velpatasvir Sofosbuvir/velpatasvir/ voxilaprevir	↑ tenofovir	Coadministration of tenofovir DF and HARVONI (ledipasvir/sofosbuvir), EPCLUSA (sofosbuvir/velpatasvir), or VOSEVI (sofosbuvir/velpatasvir/voxilaprevir) has been shown to increase tenofovir exposure (see Table 11). Patients receiving a regimen containing tenofovir DF concomitantly with HARVONI, EPCLUSA, or VOSEVI should be monitored for adverse reactions associated with tenofovir DF (see WARNINGS AND PRECAUTIONS, Drug Interactions).
--	-------------	---

a This table is not all inclusive.

b ↑ = increase, ↓ = decrease

Drugs Affecting Renal Function

Emtricitabine and tenofovir are primarily excreted by the kidneys by a combination of glomerular filtration and active tubular secretion. No drug-drug interactions due to competition for renal excretion have been observed. Since emtricitabine and tenofovir are primarily eliminated by the kidneys, coadministration of TRUVADA with drugs that reduce renal function or compete for active tubular secretion may increase serum concentrations of emtricitabine, tenofovir, and/or other renally eliminated drugs. Some examples include, but are not limited to, acyclovir, valacyclovir, ganciclovir, valganciclovir, aminoglycosides and high-dose or multiple NSAIDs.

TRUVADA should not be administered with HEPSERA (adefovir dipivoxil) (see **WARNINGS AND PRECAUTIONS, General**).

Drugs without Clinically Significant Interactions with TRUVADA

No clinically significant drug interactions have been observed between emtricitabine and famciclovir, indinavir, zidovudine, stavudine, tenofovir DF, sofosbuvir, ledipasvir/sofosbuvir, sofosbuvir/velpatasvir, and sofosbuvir/velpatasvir/voxilaprevir (see Table 9 and Table 10). Similarly, no clinically significant drug interactions have been observed between tenofovir DF and abacavir, efavirenz, emtricitabine, entecavir, indinavir, lamivudine, methadone, nelfinavir, oral contraceptives, ribavirin, saquinavir/ritonavir, sofosbuvir and tacrolimus in studies conducted in healthy volunteers (see Table 11 and Table 12).

Assessment of Drug Interactions

Drug-drug interaction studies were conducted with either TRUVADA, or the components of TRUVADA (emtricitabine or tenofovir DF) as individual agents and/or in combination.

The effects of didanosine in the presence of tenofovir are shown in Table 8.

The effects of coadministered drugs on the exposure of emtricitabine are shown in Table 9. The effects of emtricitabine on the exposure of coadministered drugs are shown in Table 10.

The effects of coadministered drugs on the exposure of tenofovir DF are shown in Table 11. The effects of tenofovir DF on the exposure of coadministered drugs are shown in Table 12.

Table 8 Drug Interactions: Pharmacokinetic Parameters for Didanosine in the Presence of Tenofovir

Didanosine ¹ Dose (mg)/ Method of Administration ²	Tenofovir Method of Administration ²	N	% Difference (90% CI) vs. Didanosine 400 mg Alone, Fasted ³	
			C _{max}	AUC
Buffered tablets				
400 once daily ⁴ × 7 days	Fasted 1 hour after didanosine	14	↑ 27 (↑ 8 to ↑ 46)	↑ 43 (↑ 30 to ↑ 57)
Enteric coated capsules				
400 once, fasted	With food, 2 hr after didanosine	26	↑ 48 (↑ 25 to ↑ 76)	↑ 48 (↑ 31 to ↑ 67)
400 once, with food	Simultaneously with didanosine	26	↑ 64 (↑ 41 to ↑ 89)	↑ 60 (↑ 44 to ↑ 79)
250 once, fasted	With food, 2 hr after didanosine	28	↓ 10 (↓ 22 to ↑ 3)	0 (↓ 11 to ↑ 12)
250 once, fasted	Simultaneously with didanosine	28	↓ 8 (↓ 19 to ↑ 5)	↑ 14 (0 to ↑ 31)
250 once, with food	Simultaneously with didanosine	28	↓ 29 (↓ 39 to ↓ 18)	↓ 11 (↓ 23 to ↑ 2)

1. See **PRECAUTIONS** regarding use of didanosine with VIREAD.
2. Administration with food was with a light meal (~373 kcal, 20% fat).
3. Increase = ↑; Decrease = ↓
4. Includes 4 subjects weighing <60 kg receiving ddi 250 mg.

Table 9 Drug Interactions: Changes in Pharmacokinetic Parameters for Emtricitabine in the Presence of the Coadministered Drug¹

Coadministered Drug	Dose of Coadministered Drug (mg)	Emtricitabine Dose (mg)	N	% Change of Emtricitabine Pharmacokinetic Parameters ² (90% CI)		
				C _{max}	AUC	C _{min}
Tenofovir DF	300 once daily × 7 days	200 once daily × 7 days	17	↓ 4 (↓ 13 to ↑ 6)	↑ 7 (0 to ↑ 4)	↑ 20 (↑ 12 to ↑ 29)
Zidovudine	300 twice daily × 7 days	200 once daily × 7 days	27	↓ 3 (↓ 10 to ↑ 4)	↓ 3 (↓ 7 to ↑ 1)	↓ 4 (↓ 12 to ↑ 4)
Indinavir	800 × 1	200 × 1	12	↓ 8 (↓ 18 to ↑ 4)	↑ 1 (↓ 6 to ↑ 9)	NC
Famciclovir	500 × 1	200 × 1	12	↓ 10 (↓ 20 to ↑ 1)	↓ 8 (↓ 14 to ↓ 1)	NC
Stavudine	40 × 1	200 × 1	6	↑ 4 (↓ 6 to ↑ 16)	↑ 2 (↓ 6 to ↑ 11)	NC

1. All interaction studies conducted in healthy volunteers.
2. ↑ = Increase; ↓ = Decrease; NC= Not Calculated

Table 10 Drug Interactions: Changes in Pharmacokinetic Parameters for Coadministered Drug in the Presence of Emtricitabine¹

Coadministered Drug	Dose of Coadministered Drug (mg)	Emtricitabine Dose (mg)	N	% Change of Coadministered Drug Pharmacokinetic Parameters ² (90% CI)		
				C _{max}	AUC	C _{min}
Tenofovir DF	300 once daily × 7 days	200 once daily × 7 days	17	↑ 3 (↓ 5 to ↑ 11)	0 (↓ 8 to ↑ 9)	↑ 2 (↓ 8 to ↑ 13)
Zidovudine	300 twice daily × 7 days	200 once daily × 7 days	27	↑ 17 (0 to ↑ 38)	↑ 13 (↑ 5 to ↑ 20)	↓ 2 (↓ 11 to ↑ 9)
Indinavir	800 × 1	200 × 1	12	↓ 2 (↓ 16 to ↑ 13)	↑ 2 (↓ 11 to ↑ 17)	NC
Famciclovir	500 × 1	200 × 1	12	↓ 7 (↓ 22 to ↑ 11)	↓ 9 (↓ 17 to ↓ 1)	NC
Stavudine	40 × 1	200 × 1	6	↑ 5 (↓ 5 to ↑ 16)	↑ 9 (↓ 17 to ↑ 44)	NC

1. All interaction studies conducted in healthy volunteers.
2. ↑ = Increase; ↓ = Decrease; NC=Not Calculated

Table 11 Drug Interactions: Changes in Pharmacokinetic Parameters for Tenofovir¹ in the Presence of the Coadministered Drug

Coadministered Drug	Dose of Coadministered Drug (mg)	N	% Change of Tenofovir Pharmacokinetic Parameters ² (90% CI)		
			C _{max}	AUC	C _{min}
Abacavir	300 single dose	8	↓ 8 (↓ 24 to ↑ 12)	↑ 4 (↓ 14 to ↑ 26)	NC
Atazanavir ³	400 once daily × 14 days	33	↑ 14 (↑ 8 to ↑ 20)	↑ 24 (↑ 21 to ↑ 28)	↑ 22 (↑ 15 to ↑ 30)
Atazanavir/ Ritonavir ³	300/100 once daily	12	↑ 34 (↑ 20 to ↑ 51)	↑ 37 (↑ 30 to ↑ 45)	↑ 29 (↑ 21 to ↑ 36)
Darunavir/ Ritonavir ⁴	300/100 twice daily	12	↑ 24 (↑ 8 to ↑ 42)	↑ 22 (↑ 10 to ↑ 35)	↑ 37 (↑ 19 to ↑ 57)
Didanosine (enteric-coated)	400 single dose	25	↓ 2 (↓ 7 to ↑ 4)	↑ 2 (↓ 2 to ↑ 5)	NC
Didanosine (buffered)	250 or 400 once daily × 7 days ⁵	14	↑ 1 (↓ 12 to ↑ 14)	↓ 5 (↓ 14 to ↑ 4)	↓ 22 (↓ 36 to ↓ 7)
Efavirenz	600 once daily × 14 days	29	↑ 7 (↓ 4 to ↑ 17)	↓ 2 (↓ 8 to ↑ 3)	↑ 2 (↓ 9 to ↑ 12)
Emtricitabine	200 once daily × 7 days	17	↑ 3 (↓ 5 to ↑ 11)	0 (↓ 8 to ↑ 9)	↑ 2 (↓ 8 to ↑ 13)
Entecavir	1 mg once daily × 10 days	28	NA	NA	NA
Indinavir	800 three times daily × 7 days	13	↑ 14 (↓ 3 to ↑ 31)	↑ 7 (↓ 5 to ↑ 19)	↑ 8 (↓ 7 to ↑ 22)
Lamivudine	150 twice daily × 7 days	15	↑ 2 (↓ 4 to ↑ 9)	↓ 3 (↓ 15 to ↑ 10)	↓ 8 (↓ 33 to ↑ 18)
Ledipasvir/ Sofosbuvir ^{6,7}	90/400 once daily x10 days	24	↑ 47 (↑ 37 to ↑ 58)	↑ 35 (↑ 29 to ↑ 42)	↑ 47 (↑ 38 to ↑ 57)
Ledipasvir/ Sofosbuvir ^{6,8}		23	↑ 64 (↑ 54 to ↑ 74)	↑ 50 (↑ 42 to ↑ 59)	↑ 59 (↑ 49 to ↑ 70)
Ledipasvir/ Sofosbuvir ⁹		15	↑ 79 (↑ 56 to ↑ 104)	↑ 98 (↑ 77 to ↑ 123)	↑ 163 (↑ 132 to ↑ 197)
Ledipasvir/ Sofosbuvir ¹⁰		14	↑ 32 (↑ 25 to ↑ 39)	↑ 40 (↑ 31 to ↑ 50)	↑ 91 (↑ 74 to ↑ 110)
Ledipasvir/ Sofosbuvir ¹¹		29	↑ 61 (↑ 51 to ↑ 72)	↑ 65 (↑ 59 to ↑ 71)	↑ 115 (↑ 105 to ↑ 126)

Coadministered Drug	Dose of Coadministered Drug (mg)	N	% Change of Tenofovir Pharmacokinetic Parameters ² (90% CI)		
			C _{max}	AUC	C _{min}
Lopinavir/ Ritonavir	400/100 twice daily × 14 days	24	↓ 33 (↓ 17 to ↑ 49)	↑ 32 (↑ 25 to ↑ 40)	↑ 28 (↑ 7 to ↑ 49)
Nelfinavir	1250 twice daily × 14 days	29	↓ 2 (↓ 9 to ↑ 5)	↑ 1 (↓ 5 to ↑ 7)	↑ 9 (↑ 2 to ↑ 17)
Saquinavir/Ritonavir	1000/100 twice daily × 14 days	35	↑ 15 (↑ 7 to ↑ 22)	↑ 14 (↑ 9 to ↑ 19)	↑ 23 (↑ 16 to ↑ 30)
Sofosbuvir ¹²	400 single dose	16	↑ 25 (↑ 8 to ↑ 45)	↓ 2 (↓ 9 to ↑ 5)	↓ 1 (↓ 9 to ↑ 7)
Sofosbuvir/Velpatasvir ¹³	400/100 once daily	24	↑ 55 (↑ 43 to ↑ 68)	↑ 30 (↑ 24 to ↑ 36)	↑ 39 (↑ 31 to ↑ 48)
Sofosbuvir/Velpatasvir ¹⁴		29	↑ 55 (↑ 45 to ↑ 66)	↑ 39 (↑ 33 to ↑ 44)	↑ 52 (↑ 45 to ↑ 59)
Sofosbuvir/Velpatasvir ¹⁵		15	↑ 77 (↑ 53 to ↑ 104)	↑ 81 (↑ 68 to ↑ 94)	↑ 121 (↑ 100 to ↑ 143)
Sofosbuvir/Velpatasvir ¹⁶		24	↑ 44 (↑ 33 to ↑ 55)	↑ 40 (↑ 34 to ↑ 46)	↑ 84 (↑ 76 to ↑ 92)
Sofosbuvir/Velpatasvir ¹⁷		24	↑ 36 (↑ 25 to ↑ 47)	↑ 35 (↑ 29 to ↑ 42)	↑ 45 (↑ 39 to ↑ 51)
Sofosbuvir/Velpatasvir ¹⁸		30	↑ 46 (↑ 39 to ↑ 54)	↑ 40 (↑ 34 to ↑ 45)	↑ 70 (↑ 61 to ↑ 79)
Sofosbuvir/Velpatasvir/Voxilaprevir ¹⁹	400/100/100 + 100 voxilaprevir ²⁰ once daily	29	↑ 48 (↑ 36 to ↑ 61)	↑ 39 (↑ 32 to ↑ 46)	↑ 47 (↑ 38 to ↑ 56)
Tacrolimus	0.05 mg/kg twice daily × 7 days	21	↑ 13 (↑ 1 to ↑ 27)	↑ 6 (↓ 1 to ↑ 13)	↑ 11 (↑ 4 to ↑ 18)
Tipranavir/Ritonavir ²¹	500/100 twice daily	22	↓ 23 (↓ 32 to ↓ 13)	↓ 2 (↓ 9 to ↑ 5)	↑ 7 (↓ 2 to ↑ 17)
	750/200 twice daily (23 doses)	20	↓ 38 (↓ 46 to ↓ 29)	↑ 2 (↓ 6 to ↑ 10)	↑ 14 (↑ 1 to ↑ 27)

1. Patients received VIREAD 300 mg once daily.
2. Increase = ↑; Decrease = ↓; NC = Not Calculated; NA = Not Available
3. Reyataz® Prescribing Information (Bristol-Myers Squibb)
4. Prezista® Prescribing Information
5. weight <60kg: 250 mg, ≥60 kg more: 400 mg
6. Data generated from simultaneous dosing with HARVONI (ledipasvir/sofosbuvir). Staggered administration (12 hours apart) provided similar results.

7. Comparison based on exposures when administered as atazanavir/ritonavir + TRUVADA coadministered with HARVONI.
8. Comparison based on exposures when administered as darunavir/ritonavir + TRUVADA coadministered with HARVONI.
9. Study conducted with ATRIPLA (efavirenz/emtricitabine/tenofovir DF) coadministered with HARVONI.
10. Study conducted with COMPLERA (emtricitabine/rilpivirine/tenofovir DF) coadministered with HARVONI.
11. Study conducted with TRUVADA (emtricitabine/tenofovir DF) + dolutegravir coadministered with HARVONI.
12. Study conducted with ATRIPLA coadministered with SOVALDI[®] (sofosbuvir).
13. Comparison based on exposures when administered as atazanavir/ritonavir + TRUVADA coadministered with EPCLUSA (sofosbuvir/velpatasvir).
14. Comparison based on exposures when administered as darunavir/ritonavir + TRUVADA coadministered with EPCLUSA.
15. Study conducted with ATRIPLA (efavirenz/emtricitabine/tenofovir DF) coadministered with EPCLUSA.
16. Study conducted with COMPLERA (emtricitabine/rilpivirine/tenofovir DF) coadministered with EPCLUSA.
17. Study conducted with STRIBILD (elvitegravir/cobicistat/emtricitabine/tenofovir DF) coadministered with EPCLUSA.
18. Administered as raltegravir + TRUVADA coadministered with EPCLUSA.
19. Comparison based on exposures when administered as darunavir + ritonavir + TRUVADA coadministered with VOSEVI.
20. Study conducted with additional voxilaprevir 100 mg to achieve voxilaprevir exposures expected in HCV-infected patients.
21. Aptivus[®] Prescribing Information.

Table 12 Drug Interactions: Changes in Pharmacokinetic Parameters for Coadministered Drug in the Presence of Tenofovir

Coadministered Drug	Dose of Coadministered Drug (mg)	N	% Change of Coadministered Drug Pharmacokinetic Parameters ¹ (90% CI)		
			C _{max}	AUC	C _{min}
Abacavir ²	300 single dose	8	↑ 12 (↓ 1 to ↑ 26)	↑ 11 (↑ 4 to ↑ 19)	NC
Atazanavir ³	400 once daily × 14 days	34	↓ 21 (↓ 27 to ↓ 14)	↓ 25 (↓ 30 to ↓ 19)	↓ 40 (↓ 48 to ↓ 32)
Atazanavir ³	Atazanavir/Ritonavir 300/100 once daily × 42 days	10	↓ 28 (↓ 50 to ↑ 5)	↓ 25 ⁷ (↓ 42 to ↓ 3)	↓ 23 ⁷ (↓ 46 to ↑ 10)
Darunavir ⁴	Darunavir/Ritonavir 300/100 once daily	12	↑ 16 (↓ 6 to ↑ 42)	↑ 21 (↓ 5 to ↑ 54)	↑ 24 (↓ 10 to ↑ 69)
Didanosine ² (enteric-coated)	250 once, simultaneously with tenofovir DF and a light meal ⁵	33	↓ 29 ⁶ (↓ 39 to ↓ 18)	↓ 11 (↓ 23 to ↑ 2) ⁶	NC
Efavirenz ²	600 once daily × 14 days	30	↓ 4 (↓ 9 to ↑ 1)	↓ 3 (↓ 7 to 0)	↓ 7 (↓ 13 to ↓ 1)
Emtricitabine ²	200 once daily × 7 days	17	↓ 4 (↓ 13 to ↑ 6)	↑ 7 (0 to ↑ 4)	↑ 20 (↑ 12 to ↑ 29)
Entecavir ²	1 mg once daily × 10 days	28	NA	↑ 13 (↑ 11 to ↑ 15)	NA
Indinavir ²	800 three times daily × 7 days	12	↓ 6 (↓ 23 to ↑ 10)	↓ 2 (↓ 12 to ↑ 8)	↑ 43 (↓ 45 to ↑ 130)
Lamivudine ²	150 twice daily × 7 days	15	↓ 29 (↓ 39 to ↓ 19)	↓ 10 (↓ 17 to ↓ 3)	↑ 17 (↑ 3 to ↑ 32)
Lopinavir ²	Lopinavir/Ritonavir 400/100 twice daily × 14 days	24	↓ 14 (↓ 23 to ↓ 4)	↓ 12 (↓ 20 to ↓ 5)	↓ 11 (↓ 22 to ↑ 1)
Ritonavir			↓ 24 (↓ 46 to ↓ 3)	↓ 22 (↓ 34 to ↓ 9)	↓ 15 (↓ 32 to ↑ 2)
Ledipasvir	Ledipasvir/Sofosbuvir 90/400 once daily ^{13,14}	24	↑ 68 (↑ 54 to ↑ 84)	↑ 96 (↑ 74 to ↑ 121)	↑ 118 (↑ 91 to ↑ 150)
Sofosbuvir			↑ 1 (↓ 12 to ↑ 15)	↑ 11 (↑ 2 to ↑ 21)	NC
GS-331007 ¹²			↑ 17 (↑ 12 to ↑ 23)	↑ 31 (↑ 25 to ↑ 36)	↑ 42 (↑ 34 to ↑ 49)

Coadministered Drug	Dose of Coadministered Drug (mg)	N	% Change of Coadministered Drug Pharmacokinetic Parameters ¹ (90% CI)		
			C _{max}	AUC	C _{min}
Ledipasvir	Ledipasvir/Sofosbuvir 90/400 once daily ^{13,15}	23	↑11 (↓ 1 to ↑ 24)	↑ 12 (0 to ↑ 25)	↑ 17 (↑ 4 to ↑ 31)
Sofosbuvir			↓ 37 (↓ 48 to ↓ 25)	↓ 27 (↓ 35 to ↓ 18)	NC
GS-331007 ¹²			↑ 10 (↑ 4 to ↑ 16)	↑ 20 (↑ 16 to ↑ 24)	↑ 26 (↑ 20 to ↑ 32)
Ledipasvir	Ledipasvir/Sofosbuvir 90/400 once daily ¹⁶	15	↓ 34 (↓ 41 to ↓ 25)	↓ 34 (↓ 41 to ↓ 25)	↓ 34 (↓ 43 to ↓ 24)
Sofosbuvir			↑ 3 (↓ 13 to ↑ 23)	↓ 6 (↓ 19 to ↑ 10)	NC
GS-331007 ¹²			↓ 14 (↓ 24 to ↓ 4)	↓ 10 (↓ 17 to ↓ 3)	↑ 7 (↑ 2 to ↑ 13)
Ledipasvir	Ledipasvir/Sofosbuvir 90/400 once daily ¹⁷	14	↑ 1 (↓ 5 to ↑ 7)	↑ 8 (↑ 2 to ↑ 15)	↑ 16 (↑ 8 to ↑ 25)
Sofosbuvir			↑ 5 (↓ 7 to ↑ 20)	↑ 10 (↑ 1 to ↑ 21)	NC
GS-331007 ¹²			↑ 6 (↑ 1 to ↑ 11)	↑ 15 (↑ 11 to ↑ 19)	↑ 18 (↑ 13 to ↑ 23)
Sofosbuvir	Sofosbuvir/Velpatasvir 400/100 once daily ¹⁸	24	↑ 12 (↓ 3 to ↑ 29)	↑ 22 (↑ 12 to ↑ 33)	NC
GS-331007 ¹²			↑ 21 (↑ 12 to ↑ 29)	↑ 32 (↑ 27 to ↑ 36)	↑ 42 (↑ 37 to ↑ 49)
Velpatasvir			↑ 55 (↑ 41 to ↑ 71)	↑ 142 (↑ 123 to ↑ 164)	↑ 301 (↑ 257 to ↑ 350)
Sofosbuvir	Sofosbuvir/Velpatasvir 400/100 once daily ¹⁹	29	↓ 38 (↓ 46 to ↓ 29)	↓ 28 (↓ 34 to ↓ 20)	NC
GS-331007 ¹²			↑ 4 (↓ 1 to ↑ 8)	↑ 13 (↑ 8 to ↑ 18)	↑ 13 (↑ 6 to ↑ 19)
Velpatasvir			↓ 24 (↓ 35 to ↓ 11)	↓ 16 (↓ 28 to ↓ 2)	↑ 1 (↓ 13 to ↑ 18)
Sofosbuvir	Sofosbuvir/Velpatasvir 400/100 once daily ²⁰	14	↑ 38 (↑ 14 to ↑ 67)	↓ 3 (↓ 17 to ↑ 14)	NC
GS-331007 ¹²			↓ 14 (↓ 20 to ↓ 7)	↓ 10 (↓ 15 to ↓ 4)	↑ 1 (↓ 5 to ↑ 7)
Velpatasvir			↓ 47 (↓ 57 to ↓ 36)	↓ 53 (↓ 61 to ↓ 43)	↓ 57 (↓ 64 to ↓ 48)

Coadministered Drug	Dose of Coadministered Drug (mg)	N	% Change of Coadministered Drug Pharmacokinetic Parameters ¹ (90% CI)		
			C _{max}	AUC	C _{min}
Sofosbuvir	Sofosbuvir/Velpatasvir 400/100 once daily ²¹	24	↑ 9 (↓ 5 to ↑ 25)	↑ 16 (↑ 9 to ↑ 24)	NC
GS-331007 ¹²			↓ 4 (↓ 10 to ↑ 1)	↑ 4 (0 to ↑ 7)	↑ 12 (↑ 7 to ↑ 17)
Velpatasvir			↓ 4 (↓ 15 to ↑ 10)	↓ 1 (↓ 12 to ↑ 11)	↑ 2 (↓ 9 to ↑ 15)
Sofosbuvir	Sofosbuvir/Velpatasvir 400/100 once daily ²²	24	↑ 1 (↓ 15 to ↑ 19)	↑ 24 (↑ 13 to ↑ 37)	NC
GS-331007 ¹²			↑ 13 (↑ 7 to ↑ 18)	↑ 35 (↑ 30 to ↑ 40)	↑ 45 (↑ 38 to ↑ 52)
Velpatasvir			↑ 5 (↓ 7 to ↑ 19)	↑ 19 (↑ 7 to ↑ 34)	↑ 37 (↑ 22 to ↑ 54)
Sofosbuvir	Sofosbuvir/Velpatasvir 400/100 once daily ²³	30	↑ 9 (↓ 3 to ↑ 23)	↑ 16 (↑ 7 to ↑ 25)	NC
GS-331007 ¹²			↓ 5 (↓ 9 to ↓ 2)	↑ 3 (0 to ↑ 6)	↑ 8 (↑ 4 to ↑ 13)
Velpatasvir			↓ 3 (↓ 13 to ↑ 8)	↓ 2 (↓ 12 to ↑ 10)	↓ 3 (↓ 13 to ↑ 7)
Sofosbuvir	400/100/100 + 100 voxilaprevir ²⁴ once daily	29	↓ 30 ²⁵ (↓ 38 to ↓ 22)	↓ 22 ²⁵ (↓ 27 to ↓ 17)	NA
GS-331007 ¹²			↑ 6 ²⁵ (↑ 1 to ↑ 10)	↑ 15 ²⁵ (↑ 12 to ↑ 19)	NA
Velpatasvir			↓ 22 ²⁵ (↓ 27 to ↓ 16)	↓ 5 ²⁴ (↓ 12 to ↑ 2)	↑ 16 ²⁵ (↑ 7 to ↑ 26)
Voxilaprevir			↑ 72 ²⁵ (↑ 51 to ↑ 97)	↑ 143 ²⁵ (↑ 115 to ↑ 175)	↑ 300 ²⁵ (↑ 244 to ↑ 365)
Methadone ⁸	40-110 once daily × 14 days ⁹	13	↑ 5 (↓ 3 to ↑ 14)	↑ 5 (↓ 2 to ↑ 13)	↑ 6 (↓ 3 to ↑ 15)
Nelfinavir ²	1250 twice daily × 14 days	29	↓ 8 (↓ 15 to ↓ 1)	↓ 7 (↓ 15 to ↑ 2)	↑ 1 (↓ 15 to ↑ 19)
M8 metabolite			↓ 8 (↓ 16 to 0)	↓ 7 (↓ 17 to ↑ 5)	↓ 2 (↓ 16 to ↑ 15)
Norgestimate	Ethinyl Estradiol/ Norgestimate (Ortho- Tricyclen [®]) Once daily × 7 days	20	↓ 6 (↓ 13 to ↑ 1)	↓ 5 (↓ 9 to ↓ 1)	↓ 4 (↓ 8 to ↑ 1)
Ethinyl estradiol ¹⁰			↓ 6 (↓ 12 to 0)	↓ 4 (↓ 9 to ↑ 1)	↓ 2 (↓ 9 to ↑ 6)
Ribavirin	600 single dose	22	↓ 5 (↓ 11 to ↑ 1)	↑ 12 (↑ 6 to ↑ 17)	NC

Coadministered Drug	Dose of Coadministered Drug (mg)	N	% Change of Coadministered Drug Pharmacokinetic Parameters ¹ (90% CI)		
			C _{max}	AUC	C _{min}
Saquinavir	1000/100 twice daily ×14 days	32	↑ 22 (↑ 6 to ↑ 41)	↑ 29 ¹¹ (↑12 to ↑48)	↑ 47 ¹¹ (↑ 23 to ↑ 76)
Ritonavir			↑ 10 (↓ 5 to ↑ 28)	↑ 11 (0 to ↑ 22)	↑ 23 (↑ 3 to ↑ 46)
Sofosbuvir	Sofosbuvir 400 single dose ²⁶	16	↓ 19 (↓ 40 to ↑10)	↓ 6 (↓ 24 to ↑16)	NC
GS-331007 ¹²			↓ 23 (↓ 30 to ↓ 16)	↓ 16 (↓ 24 to ↓ 8)	NC
Tacrolimus	0.05 mg/kg twice daily × 7 days	21	↑ 3 (↓ 3 to ↑ 9)	↑ 4 (↓ 3 to ↑ 11)	↑ 10 (↑ 2 to ↑ 17)
Tipranavir ²⁷	Tipranavir/Ritonavir 500/100 twice daily	22	↓ 17 (↓ 26 to ↓ 6)	↓ 18 (↓ 25 to ↓ 9)	↓ 21 (↓ 30 to ↓ 10)
	Tipranavir/Ritonavir 750/200 twice daily (23 doses)	20	↓ 11 (↓ 16 to ↓ 4)	↓ 9 (↓ 15 to ↓ 3)	↓ 12 (↓ 22 to 0)

- Increase = ↑; Decrease = ↓; NC = Not Calculated; NA = Not Available
- Study conducted with VIREAD (tenofovir DF).
- Reyataz Prescribing Information (Bristol-Myers Squibb)
- Prezista Prescribing Information.
- 373 kcal, 8.2 g fat
- Compared with didanosine (enteric-coated) 400 mg administered alone under fasting conditions.
- In HIV-infected patients, addition of tenofovir DF to atazanavir 300 mg plus ritonavir 100 mg, resulted in AUC and C_{min} values of atazanavir that were 2.3 and 4-fold higher than the respective values observed for atazanavir 400 mg when given alone.
- R-(active), S-and total methadone exposures were equivalent when dosed alone or with VIREAD.
- Individual subjects were maintained on their stable methadone dose. No pharmacodynamic alterations (opiate toxicity or withdrawal signs or symptoms) were reported.
- Ethinyl estradiol and 17-deacetyl norgestimate (pharmacologically active metabolite) exposures were equivalent when dosed alone or with VIREAD.
- Increases in AUC and C_{min} are not expected to be clinically relevant; hence no dose adjustments are required when tenofovir DF and ritonavir-boosted saquinavir are coadministered.
- The predominant circulating nucleoside metabolite of sofosbuvir.
- Data generated from simultaneous dosing with HARVONI (ledipasvir/sofosbuvir). Staggered administration (12 hours apart) provided similar results.
- Comparison based on exposures when administered as atazanavir/ritonavir + TRUVADA coadministered with HARVONI.
- Comparison based on exposures when administered as darunavir/ritonavir + TRUVADA coadministered with HARVONI.
- Study conducted with ATRIPLA (efavirenz/emtricitabine/tenofovir DF) coadministered with HARVONI.
- Study conducted with COMPLERA (emtricitabine/rilpivirine/tenofovir) coadministered with HARVONI.
- Comparison based on exposures when administered as atazanavir/ritonavir + TRUVADA coadministered with EPCLUSA (sofosbuvir/velpatasvir).
- Comparison based on exposures when administered as darunavir/ritonavir + TRUVADA coadministered with EPCLUSA.
- Study conducted with ATRIPLA (efavirenz/emtricitabine/tenofovir DF) coadministered with EPCLUSA.

21. Study conducted with COMPLERA (emtricitabine/rilpivirine/tenofovir DF) coadministered with EPCLUSA.
22. Study conducted with STRIBILD (elvitegravir/cobicistat/emtricitabine/tenofovir DF) coadministered with EPCLUSA.
23. Comparison based on exposures when administered as raltegravir + TRUVADA coadministered with EPCLUSA.
24. Study conducted with additional voxilaprevir 100 mg to achieve voxilaprevir exposures expected in HCV-infected patients.
25. Comparison based on exposures when administered as darunavir + ritonavir + TRUVADA coadministered with VOSEVI.
26. Study conducted with ATRIPLA coadministered with SOVALDI.
27. Aptivus Prescribing Information

Drug-Food Interactions

TRUVADA can be taken with or without food. Compared to fasted administration, dosing of TRUVADA following either a high fat meal or a light meal increased the mean AUC and C_{max} of tenofovir by 35% and 15%, respectively, without affecting emtricitabine exposures (see **ACTIONS AND CLINICAL PHARMACOLOGY, Effect of Food on Absorption**).

Drug-Herb Interactions

Interactions of TRUVADA with herbs have not been established.

Drug-Laboratory Interactions

Interactions of TRUVADA with laboratory tests have not been established.

DOSAGE AND ADMINISTRATION

Recommended Dose

Treatment of HIV-1 Infection

The dose of TRUVADA is one tablet (containing 200 mg of emtricitabine and 300 mg of tenofovir DF) once daily taken orally with or without food.

Pre-exposure Prophylaxis of HIV-1 Infection

The dose of TRUVADA is one tablet (containing 200 mg of emtricitabine and 300 mg of tenofovir DF) once daily taken orally with or without food.

Special Populations

Dose Adjustment for Renal Impairment

Treatment of HIV-1 Infection

Significantly increased drug exposures occurred when EMTRIVA or VIREAD were administered to patients with moderate to severe renal impairment (see **ACTION AND**

CLINICAL PHARMACOLOGY, Special Populations and Conditions, Renal Insufficiency). Therefore, the dosing interval of TRUVADA should be adjusted in HIV-1 infected adult patients with baseline creatinine clearance 30–49 mL/min using the recommendations in Table 13. These dosing interval recommendations are based on modeling of single-dose pharmacokinetic data in non-HIV infected subjects with varying degrees of renal impairment, including end-stage renal disease requiring hemodialysis. The safety and effectiveness of these dosing interval adjustment recommendations have not been clinically evaluated in moderate to severe renal impairment, therefore, clinical response to treatment and renal function should be closely monitored in these patients.

No dose adjustment of TRUVADA tablets is necessary with mild renal impairment patients (creatinine clearance 50-80 mL/min). Routine monitoring of calculated creatinine clearance, serum phosphorus, urine glucose, and urine protein should be performed for patients with mild renal impairment (creatinine clearance 50–80 mL/min) (see **WARNINGS AND PRECAUTIONS**).

Table 13 Dosage Adjustment for HIV-1 Infected Adult Patients with Altered Creatinine Clearance

	Creatinine Clearance (mL/min) ¹		
	≥50	30–49	<30 (Including Patients Requiring Hemodialysis)
Recommended Dosing Interval	Every 24 hours	Every 48 hours	TRUVADA should not be administered.

1. Calculated using ideal (lean) body weight.

Pre-exposure Prophylaxis of HIV-1 Infection

Do not use TRUVADA for PrEP in HIV-1 uninfected individuals with creatinine clearance below 60 mL/min (see **WARNINGS AND PRECAUTIONS**).

No dose adjustment of TRUVADA tablets is necessary with mild renal impairment patients (creatinine clearance 50-80 mL/min). Routine monitoring of calculated creatinine clearance, serum phosphorus, urine glucose and urine protein should be performed in all individuals with mild renal impairment. If a decrease in calculated creatinine clearance is observed in uninfected individuals while using TRUVADA for PrEP, evaluate potential causes and re-assess potential risks and benefits of continued use (see **WARNINGS AND PRECAUTIONS**).

Hepatic Impairment

No dose adjustment is required in patients with hepatic impairment (see **WARNINGS AND PRECAUTIONS**).

Geriatrics (>65 years of age)

Clinical studies of EMTRIVA or VIREAD did not include sufficient numbers of subjects aged 65 and over to determine whether they respond differently than younger subjects. In general, dose selection for the elderly patient should be cautious, keeping in mind the greater frequency of decreased hepatic, renal, or cardiac function, and of concomitant disease or other drug therapy.

Missed Dose

If a patient misses a dose within 12 hours of the regularly scheduled time, but then remembers it that same day, the patient should take the missed dose with food as soon as possible and resume their normal dosing schedule. If a patient misses a dose of TRUVADA by more than 12 hours and it is almost time for their next dose, the patient should not take the missed dose and simply resume the usual dosing schedule. The patient should not take more than 1 dose of TRUVADA in a day, and should not take 2 doses of TRUVADA at the same time to make up for missing a dose.

Uninfected individuals who miss doses are at greater risk of acquiring HIV-1 than those who do not miss doses (see WARNINGS AND PRECAUTIONS).

OVERDOSAGE

For management of a suspected drug overdose, please contact your regional Poison Control Centre.

If overdose occurs the patient must be monitored for evidence of toxicity, and standard supportive treatment applied as necessary.

Emtricitabine: Limited clinical experience is available at doses higher than the therapeutic dose of EMTRIVA. In one clinical pharmacology study single doses of emtricitabine 1200 mg were administered to 11 patients. No severe adverse reactions were reported. The effects of higher doses are not known.

Hemodialysis treatment removes approximately 30% of the emtricitabine dose over a 3-hour dialysis period starting within 1.5 hours of emtricitabine dosing (blood flow rate of 400 mL/min and a dialysate flow rate of 600 mL/min); however, a single treatment does not significantly affect emtricitabine C_{max} or AUC. It is not known whether emtricitabine can be removed by peritoneal dialysis.

Tenofovir DF: Limited clinical experience at doses higher than the therapeutic dose of VIREAD 300 mg is available. In one study, 600 mg tenofovir DF was administered to 8 patients orally for 28 days. No severe adverse reactions were reported. The effects of higher doses are not known.

Tenofovir is efficiently removed by hemodialysis with an extraction coefficient of approximately 54%. Following a single 300 mg dose of VIREAD, a four-hour hemodialysis session removed approximately 10% of the administered tenofovir dose.

ACTION AND CLINICAL PHARMACOLOGY

Mechanism of Action

TRUVADA is a fixed-dose combination of antiviral drugs, emtricitabine and tenofovir DF (see **VIROLOGY**).

Pharmacokinetics

TRUVADA: One TRUVADA Tablet was bioequivalent to one EMTRIVA Capsule (200 mg) plus one VIREAD Tablet (300 mg) following single-dose administration to fasting healthy subjects (N=39).

Emtricitabine: The pharmacokinetic properties of emtricitabine are summarized in Table 14. Following oral administration of EMTRIVA, emtricitabine is rapidly absorbed with peak plasma concentrations occurring at 1–2 hours post-dose. In vitro binding of emtricitabine to human plasma proteins is <4% and is independent of concentration over the range of 0.02–200 µg/mL. Following administration of radiolabelled emtricitabine, approximately 86% is recovered in the urine and 13% is recovered as metabolites. The metabolites of emtricitabine include 3'-sulfoxide diastereomers and their glucuronic acid conjugate. Emtricitabine is eliminated by a combination of glomerular filtration and active tubular secretion. Following a single oral dose of EMTRIVA, the plasma emtricitabine half-life is approximately 10 hours.

Tenofovir DF: The pharmacokinetic properties of tenofovir DF are summarized in Table 14. Following oral administration of VIREAD, maximum tenofovir serum concentrations are achieved in 1.0 ± 0.4 hour. In vitro binding of tenofovir to human plasma proteins is <0.7% and is independent of concentration over the range of 0.01–25 µg/mL. Approximately 70–80% of the intravenous dose of tenofovir is recovered as unchanged drug in the urine. Tenofovir is eliminated by a combination of glomerular filtration and active tubular secretion. Following a single oral dose of VIREAD, the terminal elimination half-life of tenofovir is approximately 17 hours.

Table 14 Single Dose Pharmacokinetic Parameters for Emtricitabine and Tenofovir in Adults

	Emtricitabine	Tenofovir
Fasted Oral Bioavailability ² (%)	92 (83.1–106.4)	25 (NC–45.0) ¹
Plasma Terminal Elimination Half-Life ² (hr)	10 (7.4–18.0)	17 (12.0–25.7)
C _{max} ³ (µg/mL)	1.8 ± 0.72 ⁴	0.30 ± 0.09
AUC ³ (µg·hr/mL)	10.0 ± 3.12 ⁴	2.29 ± 0.69
CL/F ³ (mL/min)	302 ± 94	1043 ± 115
CL _{renal} ³ (mL/min)	213 ± 89	243 ± 33

1. NC = Not calculated
2. Median (range)
3. Mean ± SD
4. Data presented as steady state values.

Effects of Food on Oral Absorption

TRUVADA may be administered with or without food. Administration of TRUVADA following a high fat meal (784 kcal; 49 grams of fat) or a light meal (373 kcal; 8 grams of fat) delayed the time of tenofovir C_{max} by approximately 0.75 hour. The mean increases in tenofovir AUC and C_{max} were approximately 35% and 15%, respectively, when administered with a high fat or light meal, compared to administration in the fasted state. In previous safety and efficacy studies, VIREAD (tenofovir) was taken under fed conditions. Emtricitabine systemic exposures (AUC and C_{max}) were unaffected when TRUVADA was administered with either a high fat or a light meal.

Special Populations and Conditions

Pediatrics and Geriatrics

Pharmacokinetics of emtricitabine and tenofovir have not been fully evaluated in children (<18 years) or in the elderly (>65 years).

Race

Emtricitabine: No pharmacokinetic differences due to race have been identified following the administration of EMTRIVA.

Tenofovir DF: There were insufficient numbers from racial and ethnic groups other than Caucasian to adequately determine potential pharmacokinetic differences among these populations.

Gender

Emtricitabine and tenofovir DF: Emtricitabine and tenofovir pharmacokinetics are similar in male and female patients.

Hepatic Insufficiency

The pharmacokinetics of tenofovir following a 300 mg single dose of VIREAD have been studied in non-HIV infected subjects with moderate to severe hepatic impairment. There were no substantial alterations in tenofovir pharmacokinetics in subjects with hepatic impairment compared with unimpaired subjects. The pharmacokinetics of TRUVADA or emtricitabine have not been studied in patients with hepatic impairment; however, emtricitabine has not been shown to be significantly metabolized by liver enzymes, so the impact of liver impairment is likely to be limited.

Renal Insufficiency

The pharmacokinetics of emtricitabine and tenofovir are altered in patients with renal insufficiency. In patients with creatinine clearance <50 mL/min, C_{max} and $AUC_{0-\infty}$ of emtricitabine and tenofovir were increased (see **WARNINGS, Nephrotoxicity**).

It is recommended that the dosing interval for TRUVADA be modified in HIV-1 infected patients with creatinine clearance 30–49 mL/min. TRUVADA should not be used in HIV-1 infected patients with creatinine clearance <30 mL/min and in patients with end-stage renal disease requiring dialysis (see **DOSAGE AND ADMINISTRATION**).

TRUVADA for PrEP has not been studied and should not be used in HIV-1 uninfected individuals with creatinine clearance below 60 mL/min. (see **DOSAGE AND ADMINISTRATION**).

STORAGE AND STABILITY

Store at 15–30 °C (59–86 °F).

- Keep container tightly closed
- Dispense only in original container
- Do not use if seal over bottle opening is broken or missing.

SPECIAL HANDLING INSTRUCTIONS

There are no special handling instructions.

DOSAGE FORMS, COMPOSITION AND PACKAGING

TRUVADA is available as tablets. Each tablet contains 200 mg of emtricitabine and 300 mg of tenofovir DF (which is equivalent to 245 mg of tenofovir disoproxil), as active ingredients. The tablets also include the following inactive ingredients: croscarmellose

sodium, lactose monohydrate, magnesium stearate, microcrystalline cellulose, and pregelatinized starch (gluten free). The tablets are coated with Opadry II Blue Y-30-10701, which contains FD&C Blue #2 aluminum lake, hydropropylmethylcellulose 2910, lactose monohydrate, titanium dioxide, and triacetin. The tablets are blue, capsule-shaped, film-coated, debossed with “GILEAD” on one side and with “701” on the other side. Each bottle contains 30 tablets and a desiccant (silica gel canister or sachet) and is closed with a child-resistant closure.

PART II. SCIENTIFIC INFORMATION

PHARMACEUTICAL INFORMATION

Drug Substance

Emtricitabine:

Common Name: emtricitabine (USAN)

Chemical Name: 5-fluoro-1-(2R,5S)-[2-(hydroxymethyl)-1,3-oxathiolan-5-yl]cytosine

Empirical Formula: C₈H₁₀FN₃O₃S

Molecular Weight: 247.24

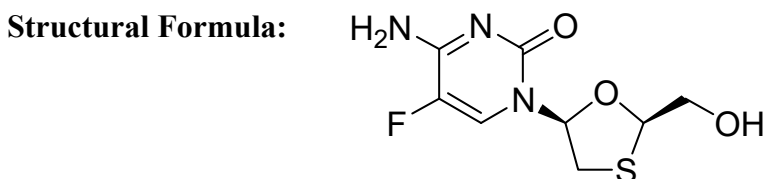

Physicochemical

Properties:

Physical Description: Emtricitabine is a white to off-white crystalline powder.

Solubility: The solubility of emtricitabine is approximately 112 mg/mL in water at 25 °C. The partition coefficient (log p) for emtricitabine is -0.43 and the pKa is 2.65.

Tenofovir DF:

Common Name: tenofovir disoproxil fumarate (USAN)

Chemical Name: 9-[(R)-2-[[bis[[[(isopropoxycarbonyl)oxy]methoxy]phosphinyl]-methoxy]propyl]adenine fumarate (1:1)

Empirical Formula: C₁₉H₃₀N₅O₁₀P • C₄H₄O₄

Molecular Weight: 635.52

Structural Formula:

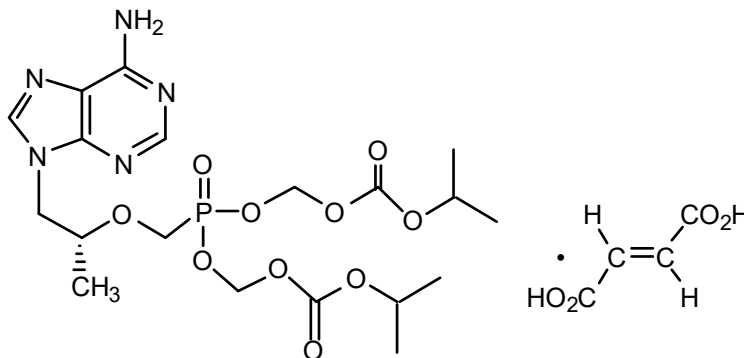

Physicochemical Properties:

Physical Description: Tenofovir disoproxil fumarate is a white to off-white crystalline powder.

Solubility: The solubility of tenofovir disoproxil fumarate is 13.4 mg/mL in water at 25 °C. The partition coefficient (log p) for tenofovir disoproxil is 1.25 and the pKa is 3.75.

CLINICAL TRIALS

Clinical Studies in Patients with HIV-1 Infection

Study Demographics and Trial Design

Description of Clinical Studies

For safety and efficacy studies using EMTRIVA or VIREAD in combination with other antiretroviral agents, also consult the Product Monograph for these products.

Clinical Study 934 supports the use of TRUVADA tablets for the treatment of HIV-1 infection. Additional data in support of the use of TRUVADA are derived from Study 903, in which lamivudine and tenofovir DF were used in combination in treatment-naïve adults, and clinical Study 303 in which EMTRIVA and lamivudine demonstrated comparable

efficacy, safety and resistance patterns as part of multidrug regimens (see Table 19 and Table 20).

Table 15 Study 934 EMTRIVA + VIREAD + Efavirenz Compared with Lamivudine/Zidovudine + Efavirenz

Study Number	Trial Design	Dosage, Route of Administration and Duration	Study Subjects (N=511)	Mean Age	Gender
GS-01-934	Randomized, open-label, parallel, multicenter, active controlled study. Arm 1: emtricitabine+ tenofovir DF+ efavirenz Arm 2: lamivudine/ zidovudine + efavirenz	Arm 1 ¹ : efavirenz 600 mg once daily for oral administration, emtricitabine 200 mg once and tenofovir DF 300 mg once daily Arm 2: efavirenz 600 mg once daily for oral administration and Combivir (lamivudine/zidovudine) 150/300 mg twice daily. 144 weeks	Antiretroviral naïve patients (HIV-1 RNA > 10,000 copies/mL) (N=511)	Mean 38 years (18–80)	Male : 86% Female: 14%

¹From weeks 96 to 144 of the study, patients received TRUVADA with efavirenz in place of emtricitabine + VIREAD

Data through 144 weeks are reported for Study 934, a randomized, open-label, active controlled multicenter study comparing EMTRIVA + VIREAD administered in combination with efavirenz versus lamivudine/zidovudine administered in combination with efavirenz in 511 antiretroviral-naïve patients. From weeks 96 to 144 of the study, patients randomized to EMTRIVA + VIREAD received TRUVADA with efavirenz in place of EMTRIVA + VIREAD. Patients had a mean age of 38 years (range 18–80), 86% were male, 59% were Caucasian and 23% were Black. The mean baseline CD4 cell count was 245 cells/mm³ (range 2–1191) and median baseline plasma HIV-1RNA was 5.01 log₁₀ copies/mL (range 3.56–6.54). Patients were stratified by baseline CD4 count (< or ≥200 cells/mm³); 41% had CD4 cell counts <200 cells/mm³ and 51% of patients had baseline viral loads >100,000 copies/mL.

EMTRIVA:

Table 16 Study 303: EMTRIVA QD + Stable Background Therapy (SBT) Compared to Lamivudine BID + SBT

Study No.	Trial Design	Dosage, Route of Administration and Duration	Study Subjects (N=440)	Mean Age (Range)	Gender
FTC-303	Randomized (2:1), open-label, active-controlled switch study. Arm 1: emtricitabine + (d4T or ZDV + PI or NNRTI) Arm 2: lamivudine + (d4T or ZDV + PI or NNRTI)	Arm 1: emtricitabine 200 mg capsules orally, QD + (d4T or ZDV + PI or NNRTI) for 48 weeks Arm 2: lamivudine 150 mg tablet orally, BID + (d4T or ZDV + PI or NNRTI) for 48 weeks	Stable treatment-experienced (HIV-1 RNA <400 copies/mL) (N=440)	42 years (22–80)	Male: 86% Female: 14%

Study 303 was a 48-week, open-label, active-controlled multicenter study comparing EMTRIVA (200 mg QD) to lamivudine, in combination with stavudine or zidovudine and a protease inhibitor or NNRTI in 440 patients who were on a lamivudine-containing triple-antiretroviral drug regimen for at least 12 weeks prior to study entry and had HIV-1 RNA ≤400 copies/mL.

Patients were randomized 1:2 to continue therapy with lamivudine (150 mg BID) or to switch to EMTRIVA (200 mg QD). All patients were maintained on their stable background regimen. Patients had a mean age of 42 years (range 22–80), 86% were male, 64% Caucasian, 21% African-American and 13% Hispanic. Patients had a mean baseline CD4 cell count of 527 cells/mm³ (range 37–1909), and a median baseline plasma HIV RNA of 1.7 log₁₀ copies/mL (range 1.7–4.0). The median duration of prior antiretroviral therapy was 27.6 months.

VIREAD:

Table 17 Study 903: VIREAD + Lamivudine + Efavirenz Compared with Stavudine + Lamivudine + Efavirenz

Study No.	Trial Design	Dosage, Route of Administration and Duration	Study Subjects (N=600)	Mean Age (Range)	Gender
GS-99-903	Randomized (1:1), double-blind, active-controlled, equivalence study. Arm 1: tenofovir DF + lamivudine + efavirenz Arm 2: stavudine + lamivudine + efavirenz	Arm 1: tenofovir DF 300 mg tablets QD, stavudine placebo capsules BID, lamivudine 150 mg tablets BID, efavirenz 600 mg QD Arm 2: tenofovir DF placebo tablets QD, stavudine ¹ capsules 40/30 mg BID, lamivudine 150 mg tablets BID, efavirenz 600 mg QD All for oral (PO) administration for 144 weeks double-blind phase followed by 192-week open-label phase. (Nevirapine 200 mg BID could replace efavirenz in the event of efavirenz-associated central nervous system toxicity or rash.)	Treatment-naïve (HIV-1 RNA >5,000 copies/mL) (N=600)	36 years (18–64)	Male: 74% Female: 26%

1. Stavudine/placebo capsules 20/15 mg BID as need for dose reduction.

Study 903 is a double-blind, active-controlled multicenter study comparing VIREAD (300 mg QD) administered in combination with lamivudine and efavirenz versus stavudine, lamivudine, and efavirenz in 600 antiretroviral-naïve patients. Patients had a mean age of 36 years (range 18–64), 74% were male, 64% were Caucasian and 20% were Black. The mean baseline CD4 cell count was 279 cells/mm³ (range 3–956) and median baseline plasma HIV-1 RNA was 77,600 copies/mL (range 417–5,130,000). Patients were stratified by baseline HIV-1 RNA and CD4 count. Forty-three percent of patients had baseline viral loads >100,000 copies/mL and 39% had CD4 cell counts <200 cells/mm³.

Study Results

EMTRIVA and VIREAD

Study 934: EMTRIVA + VIREAD + Efavirenz Compared with Lamivudine/Zidovudine + Efavirenz

Treatment outcomes through 48 and 144 weeks for those patients who did not have efavirenz resistance at baseline are presented in Table 18.

Table 18 Outcomes of Randomized Treatment at Weeks 48 and 144 (Study 934)

Outcome	At Week 48		At Week 144 ¹	
	EMTRIVA+ VIREAD +EFV	3TC+AZT +EFV	EMTRIVA+ VIREAD+ EFV	3TC/AZT +EFV
	(N=244)	(N=243)	(N=227)	(N=229)
Responder ²	84%	73%	71%	58%
Virologic failure ³	2%	4%	3%	6%
Rebound	1%	3%	2%	5%
Never suppressed	0%	0%	0%	0%
Change in antiretroviral regimen	1%	1%	1%	1%
Death	<1%	1%	1%	1%
Discontinued due to adverse event	4%	9%	5%	12%
Discontinued for other reasons ⁴	10%	14%	20%	22%

1. Patients who were responders at Week 48 or Week 96 but did not consent to continue study after Week 48 or Week 96 were excluded from analysis.
2. Patients achieved and maintained confirmed HIV-1 RNA <400 copies/mL through Week 48.
3. Includes confirmed viral rebound and failure to achieve confirmed <400 copies/mL through Week 48.
4. Includes lost to follow-up, patient withdrawal, non-compliance, protocol violation and other reasons.

In this study, EMTRIVA + VIREAD in combination with efavirenz demonstrated statistically significant superiority to lamivudine/zidovudine in combination with efavirenz in achieving and maintaining HIV-1 RNA <400 copies/mL through 48 weeks and 144 weeks (Table 18). The difference in the percentages of responders, stratified by baseline CD4 cell count (< or ≥200 cells/mm³), between the EMTRIVA + VIREAD group and the lamivudine/zidovudine group was 11.4%, and the 95% CI was 4.3% to 18.6% (p=0.002) at Week 48 and was 13% at Week 144, 95% CI = 4% to 22% (p=0.004). Through 48 weeks of therapy, 80% and 70% of patients in the EMTRIVA + VIREAD and the lamivudine/zidovudine arms, respectively, achieved and maintained HIV-1 RNA <50 copies/mL (64% and 56%, respectively, through Week 144). The difference in the percentages of responders stratified by baseline CD4 cell count (< or ≥200 cells/mm³) between the EMTRIVA + VIREAD group and the lamivudine/zidovudine group was 9.1%,

and the 95% CI was 1.6% to 16.6% (p=0.021) at Week 48 and was 8% at Week 144, 95% CI = -1% to 17% (p=0.082). The mean increase from baseline in CD4 cell count was 190 cells/mm³ for the EMTRIVA + VIREAD + efavirenz arm, and 158 cells/mm³ for the lamivudine/zidovudine + efavirenz arm (p=0.002) at Week 48 (312 and 271 cells/mm³, respectively, at Week 144, p=0.089).

The difference in the proportion of patients who achieved and maintained HIV-1 RNA <400 copies/mL through 48 weeks largely results from the higher number of discontinuations due to adverse events and other reasons in the zidovudine/lamivudine group in this open label study.

EMTRIVA:

Study 303: EMTRIVA QD + Stable Background Therapy (SBT) Compared to Lamivudine BID + SBT

Treatment outcomes through 48 weeks are presented in Table 19.

Table 19 Outcomes of Randomized Treatment at Week 48 (Study 303)

Outcome at Week 48	EMTRIVA + ZDV/d4T + NNRTI/PI (N=294)	Lamivudine + ZDV/d4T + NNRTI/PI (N=146)
Responder ¹	77% (67%)	82% (72%)
Virologic Failure ²	7%	8%
Death	0%	<1%
Study Discontinuation Due to Adverse Event	4%	0%
Study Discontinuation For Other Reasons ³	12%	10%

1. Patients achieved and maintained confirmed HIV RNA <400 copies/mL (<50 copies/mL) through Week 48.
2. Includes patients who failed to achieve virologic suppression or rebounded after achieving virologic suppression.
3. Includes lost to follow-up, patient withdrawal, non-compliance, protocol violation and other reasons.

The mean increase from baseline in CD4 cell count was 29 cells/mm³ for the EMTRIVA arm and 61 cells/mm³ for the lamivudine arm. Through 48 weeks, in the EMTRIVA group 2 patients (0.7%) experienced a new CDC Class C event, compared to 2 patients (1.4%) in the lamivudine group.

VIREAD:

Study 903: VIREAD + Lamivudine + Efavirenz Compared with Stavudine + Lamivudine + Efavirenz

Treatment outcomes at Week 48 and Week 144 are presented in Table 20 below.

Table 20 Outcomes of Randomized Treatment (Study 903)

Outcomes	At Week 48		At Week 144	
	VIREAD + 3TC + EFV (N=299)	Stavudine + 3TC + EFV (N=301)	VIREAD + 3TC + EFV (N=299)	Stavudine + 3TC + EFV (N=301)
	%	%	%	%
Responder ¹	79% (76%)	82% (79%)	68% (62%)	62% (58%)
Virologic failure ²	6%	4%	10%	8%
Rebound	5%	3%	8%	7%
Never suppressed	0%	1%	0%	0%
Added an antiretroviral agent	1%	1%	2%	1%
Death	<1%	1%	<1%	2%
Discontinued due to adverse event	6%	6%	8%	13%
Discontinued for other reasons ³	8%	7%	14%	15%

1. Patients achieved and maintained confirmed HIV-1 RNA <400 copies/mL (<50 copies/mL) at Weeks 48 and 144.
2. Includes confirmed viral rebound and failure to achieve confirmed <400 copies/mL through Week 48 and 144.
3. Includes lost to follow-up, patient's withdrawal, noncompliance, protocol violation and other reasons.

Through 48 weeks, the mean increase from baseline in CD4 cell count was 169 cells/mm³ for the VIREAD arm and 167 cells/mm³ for the stavudine arm. Eight patients in the VIREAD group and six patients in the stavudine group experienced a new CDC Class C event.

Through 144 weeks, the mean increase from baseline in CD4 cell count was 263 cells/mm³ for the VIREAD arm and 283 cells/mm³ for the stavudine arm. Eleven patients in the VIREAD group and nine patients in the stavudine group experienced a new CDC Class C event.

Clinical Studies in HIV-1 Uninfected Subjects

The iPrEx study and Partners PrEP study support the use of TRUVADA to help reduce the risk of acquiring HIV-1.

iPrEx Trial

The study demographics and trial design for the iPrEx Trial are summarized in Table 21.

Table 21 Study Demographics and Trial Design of iPrEx Trial

Study No.	Trial Design	Dosage, Route of Administration and Duration	Study Subjects (N=2499)	Mean Age (Range)	Gender
CO-US-104-0288 (iPrEx)	Randomized, double-blind, placebo-controlled multinational study in men and transgender women who have sex with men and with evidence of high risk behavior for HIV-1 infection Arm 1: TRUVADA Arm 2: placebo	Arm 1: TRUVADA tablet taken orally QD Arm 2: Placebo tablet taken orally QD Duration of treatment was variable. Subjects remained on treatment until the target number of seroconversion events was identified and the last enrolled study subject completed 48 weeks of treatment. Subjects were followed for at least 8 weeks follow up. HBsAg reactive subjects were followed for hepatic flares for 24 weeks after study drug discontinuation. Subjects who HIV-1 seroconverted during study were followed through at least 24 weeks after the last dose of study drugs	Randomized: 1251 – TRUVADA 1248 –placebo Race: Asian – 5% Black – 9% White – 18% Hispanic/Latino – 72%	27 (18 to 67 years)	Male: 100% subjects born male 29 (1%) report current identity as female

Evidence of high risk behavior included any one of the following reported to have occurred up to six months prior to study screening: no condom use during anal intercourse with an HIV-1 positive partner or a partner of unknown HIV-1 status; anal intercourse with more than 3 sex partners; exchange of money, gifts, shelter or drugs for anal sex; sex with male partner and diagnosis of sexually transmitted infection; no consistent use of condoms with sex partner known to be HIV-1 positive.

All subjects received monthly HIV-1 testing, risk-reduction counseling, condoms and management of sexually transmitted infections.

Partners PrEP Study

The demographics and trial design for the Partners PrEP study are summarized in Table 22.

Table 22 Study Demographics and Trial Design of Partners PrEP Trial

Study No.	Trial Design	Dosage, Route of Administration and Duration	Study Subjects (N=4758)	Mean Age (Range)	Gender
CO-US-104-0380 (Partners PrEP)	Randomized, double-blind, placebo-controlled 3-arm trial conducted in serodiscordant heterosexual couples in Kenya and Uganda	Arm 1: Viread tablet taken orally QD Arm 2: TRUVADA tablet taken orally QD Arm 3: Matched Placebo tablets, taken orally QD. Duration of study drug treatment was variable. Subjects received the assigned study drugs once daily for a minimum of 24 months up to a maximum of 36 months.	Randomized: 1589 –TDF 1583 – TRUVADA 1586 – placebo	33–34	Female: 38% Male 62%

All subjects received monthly HIV-1 testing, evaluation of adherence, assessment of sexual behavior, and safety evaluations. Women were also tested monthly for pregnancy. Women who became pregnant during the trial had study drug interrupted for the duration of the pregnancy and while breastfeeding. The uninfected partner subjects were predominantly male (61–64% across study drug groups).

Study Results

iPrEx Study

Subjects were followed for 4237 person-years. The primary outcome measure for the study was the incidence of documented HIV-1 seroconversion. The results of the iPrEx study are summarized below in Table 23.

Table 23 iPrEx Study: Relative Risk Reduction Through End-of-Treatment Cutoff (Primary Analysis; mITT Analysis^a)

	Placebo	TRUVADA	P-value ^b
End of Treatment^c			
mITT Analysis	N=1217	N=1224	0.002
Person-Years follow-up ^d	2113	2124	
Number of HIV-1 Infections (Seroconversions)	83	48	
Relative Risk Reduction (2-sided 95% CI)	42% (18%, 60%)		

Abbreviation: CI = confidence interval

- a Modified Intent-to-Treat (mITT) analysis excludes subjects who do not have follow-up HIV test and who were infected at enrollment
- b p-values by log rank test
- c End of treatment is defined as the next post-treatment visit after this date (approximately one month). This analysis excludes post-treatment stop seroconversions.
- d Time to first evidence of seroconversion for those with event

Risk reduction was found to be higher (53%; 95% CI: 34% to 72%) among subjects who reported previous unprotected anal intercourse (URAI) at screening (732 and 753 subjects reported URAI within the last 12 weeks at screening in the TRUVADA and placebo groups, respectively). In a post-hoc case control study of plasma and intracellular drug levels in about 10% of study subjects, risk reduction appeared to be the greatest in subjects with detectable intracellular tenofovir. Efficacy was therefore strongly correlated with adherence.

Partners PrEP Study

The efficacy analyses results of the Partner’s PrEP study are summarized in Table 24 below.

Table 24 Partners PrEP Study: Relative Risk Reduction and HIV-1 Seroincidence for Partner Subjects (Primary Analysis; mITT Analysis^a)

	TRUVADA	VIREAD	Placebo	Total
mITT Analysis	N=1576	N=1579	N=1578	N=4733
Person-years of follow-up ^b	2616	2604	2607	7827
Number of HIV-1 Infections (Seroconversions)	13	17	52	82
HIV-1 incidence, per 100 person-years	0.50	0.65	1.99	1.05
Relative Risk Reduction (2-sided 95% CI)	75% (55-87%)	67% (44-81%)		
p-value ^c	<0.0001	<0.0001		

- a Modified Intent-to-Treat (mITT) analysis excludes subjects who were infected at enrollment
- b Time to first evidence of seroconversion for those with event

c p-values using Cox's proportional hazards model for the active study drug relative to placebo

Two of the 13 seroconversions in the TRUVADA arm and 3 of the 52 seroconversions in the placebo arm occurred in women during treatment interruptions for pregnancy. In a post-hoc case control study of plasma drug levels in about 10% of study subjects, risk reduction was most pronounced in subjects with detectable plasma tenofovir. Efficacy was therefore strongly correlated with adherence.

VIROLOGY (MICROBIOLOGY)

Mechanism of Action

Emtricitabine: Emtricitabine, a synthetic nucleoside analog of cytidine, is phosphorylated by cellular enzymes to form emtricitabine 5'-triphosphate. Emtricitabine 5'-triphosphate inhibits the activity of the HIV-1 reverse transcriptase (RT) by competing with the natural substrate deoxycytidine 5'-triphosphate and by being incorporated into nascent viral DNA which results in chain termination. Emtricitabine 5'-triphosphate is a weak inhibitor of mammalian DNA polymerases α , β , ϵ and mitochondrial DNA polymerase γ .

Tenofovir DF: Tenofovir DF is an acyclic nucleoside phosphonate diester analog of adenosine monophosphate. Tenofovir DF requires initial diester hydrolysis for conversion to tenofovir and subsequent phosphorylations by cellular enzymes to form tenofovir diphosphate. Tenofovir diphosphate inhibits the activity of HIV-1 RT by competing with the natural substrate deoxyadenosine 5'-triphosphate and, after incorporation into DNA, by DNA chain termination. Tenofovir diphosphate is a weak inhibitor of mammalian DNA polymerases α , β , and mitochondrial DNA polymerase γ .

Antiviral Activity

Emtricitabine and tenofovir DF: In combination studies evaluating the in vitro antiviral activity of emtricitabine and tenofovir together, synergistic antiviral effects were observed. Additive to synergistic effects were observed in combination studies with protease inhibitors, integrase strand transfer inhibitors, and with nucleoside and non-nucleoside analogue inhibitors of HIV-1 reverse transcriptase.

Emtricitabine: The in vitro antiviral activity of emtricitabine against laboratory and clinical isolates of HIV was assessed in lymphoblastoid cell lines, the MAGI-CCR5 cell line, and peripheral blood mononuclear cells. The IC_{50} values for emtricitabine were in the range of 0.0013–0.64 μ M (0.0003–0.158 μ g/mL). In drug combination studies of emtricitabine with nucleoside reverse transcriptase inhibitors (abacavir, lamivudine, stavudine, zalcitabine, or zidovudine), non-nucleoside reverse transcriptase inhibitors (delavirdine, efavirenz, or nevirapine), protease inhibitors (amprenavir, nelfinavir, ritonavir, or saquinavir), and with integrase strand transfer inhibitors, additive to synergistic effects were observed. Most of these drug combinations have not been studied in humans. Emtricitabine displayed antiviral activity in vitro against HIV-1 clades A, B, C, D, E, F, and G (IC_{50} values ranged from 0.007–0.075 μ M) and showed strain specific activity against HIV-2 (IC_{50} values ranged from 0.007–1.5 μ M).

Tenofovir DF: The in vitro antiviral activity of tenofovir against laboratory and clinical isolates of HIV-1 was assessed in lymphoblastoid cell lines, primary monocyte/macrophage cells and peripheral blood lymphocytes. The IC₅₀ (50% inhibitory concentration) values for tenofovir were in the range of 0.04–8.5 µM. In drug combination studies of tenofovir with integrase strand transfer inhibitors, nucleoside reverse transcriptase inhibitors (abacavir, didanosine, lamivudine, stavudine, zalcitabine, or zidovudine), non-nucleoside reverse transcriptase inhibitors (delavirdine, efavirenz, or nevirapine), and protease inhibitors (amprenavir, indinavir, nelfinavir, ritonavir, or saquinavir), additive to synergistic effects were observed. Most of these drug combinations have not been studied in humans. Tenofovir displayed antiviral activity in vitro against HIV-1 clades A, B, C, D, E, F, G, and O (IC₅₀ values ranged from 0.5–2.2 µM).

Prophylactic Activity in a Nonhuman Primate Model of HIV Transmission

Emtricitabine and tenofovir DF: The prophylactic activity of the combination of daily oral emtricitabine and tenofovir DF was evaluated in a controlled study of macaques inoculated once weekly for 14 weeks with SIV/HIV-1 chimeric virus (SHIV) applied to the rectal surface. Of the 18 control animals, 17 became infected after a median of 2 weeks. In contrast, 4 of the 6 animals treated daily with oral emtricitabine and tenofovir DF remained uninfected and the two infections that did occur were significantly delayed until 9 and 12 weeks and exhibited reduced viremia. An M184I-expressing FTC-resistant variant emerged in 1 of the 2 macaques after 3 weeks of continued drug exposure.

Resistance

Emtricitabine and tenofovir DF: HIV-1 isolates with reduced susceptibility to the combination of emtricitabine and tenofovir have been selected in vitro. Genotypic analysis of these isolates identified the M184V/I and/or K65R amino acid substitutions in the viral RT. In addition, a K70E substitution in HIV-1 reverse transcriptase has been selected by tenofovir and results in reduced susceptibility to tenofovir.

In Study 934 (EMTRIVA + VIREAD + efavirenz compared with lamivudine/zidovudine + efavirenz), resistance analysis was performed on HIV isolates from all patients with >400 copies/mL of HIV-1 RNA at Week 144 or early discontinuation. Genotypic resistance to efavirenz, predominantly the K103N mutation, was the most common form of resistance that developed. Resistance to efavirenz occurred in 13/19 (68%) analyzed patients in the EMTRIVA + VIREAD group and in 21/29 (72%) analyzed patients in the lamivudine/zidovudine group. The M184V mutation, associated with resistance to EMTRIVA and lamivudine, was observed in 2/19 (11%) analyzed patients in the EMTRIVA + VIREAD group and in 10/29 (34%) analyzed patients in the lamivudine/zidovudine group.

In treatment-naïve patients treated with EMTRIVA + VIREAD + efavirenz, none of the HIV isolates from 19 patients analyzed for resistance showed reduced susceptibility to tenofovir or the presence of the K65R or K70E mutation.

Emtricitabine: Emtricitabine-resistant isolates of HIV have been selected in vitro. Genotypic analysis of these isolates showed that the reduced susceptibility to emtricitabine was associated with a mutation in the HIV RT gene at codon 184 which resulted in an amino acid substitution of methionine by valine or isoleucine (M184V/I).

Emtricitabine-resistant isolates of HIV have been recovered from some patients treated with emtricitabine alone or in combination with other antiretroviral agents. In a clinical study, viral isolates from 6/16 (37.5%) treatment-naïve patients with virologic failure showed >20-fold reduced susceptibility to emtricitabine. Genotypic analysis of these isolates showed that the resistance was due to M184V/I mutations in the HIV RT gene.

Tenofovir DF: The K65R and K70E substitutions selected by tenofovir are also selected in some HIV-1-infected patients treated with abacavir or didanosine. HIV-1 isolates with the K65R and K70E substitutions also showed reduced susceptibility to emtricitabine and lamivudine. Therefore, cross-resistance among these NRTIs may occur in patients whose virus harbors the K65R or K70E substitutions. HIV-1 isolates with reduced susceptibility to tenofovir have been selected in vitro. These viruses expressed a K65R mutation in RT and showed a 2–4 fold reduction in susceptibility to tenofovir.

Tenofovir-resistant isolates of HIV-1 have also been recovered from some patients treated with VIREAD in combination with certain antiretroviral agents. In treatment-naïve patients, 7/29 (24%) isolates from patients failing VIREAD + lamivudine + efavirenz at 48 weeks showed >1.4 fold (median 3.4) reduced susceptibility in vitro to tenofovir.

In treatment-experienced patients, 14/304 (4.6%, studies 902 and 907) isolates from patients failing VIREAD at 96 weeks showed >1.4 fold (median 2.7) reduced susceptibility to tenofovir. Genotypic analysis of the resistant isolates showed a mutation in the HIV-1 RT gene resulting in the K65R amino acid substitution.

iPrEx Trial: In a clinical study of HIV-1 seronegative subjects (**iPrEx Trial**, see **CLINICAL TRIALS**), no mutations associated with resistance to emtricitabine or tenofovir were detected at the time of seroconversion among 48 subjects in the TRUVADA group and 83 subjects in the placebo group who became infected with HIV-1 during the trial. Ten subjects were observed to be HIV-1 infected at time of enrollment. The M184V/I substitutions associated with resistance to emtricitabine were observed in 3 of the 10 subjects (2 of 2 in the TRUVADA group and 1 of 8 in the placebo group). One of the two subjects in the TRUVADA group harbored wild type virus at enrollment and developed the M184V substitution 4 weeks after enrollment. The other subject had indeterminate resistance at enrollment but was found to have the M184I substitution 4 weeks after enrollment.

Partners PrEP Trial: In a clinical study of HIV-1 seronegative subjects (**Partners PrEP Trial**, see **CLINICAL TRIALS**), no variants expressing amino acid substitutions associated with resistance to emtricitabine or tenofovir were detected at the time of seroconversion among 12 subjects in the TRUVADA group, 15 subjects in the VIREAD group, and 51 subjects in the placebo group. Fourteen subjects were observed to be HIV-1 infected at the time of enrollment (3 in the TRUVADA group, 5 in the VIREAD group, and 6 in the placebo group). One of the three subjects in the TRUVADA group who was infected with wild type

virus at enrollment selected an M184V expressing virus by week 12. Two of the five subjects in the VIREAD group had tenofovir-resistant viruses at the time of seroconversion; one subject infected with wild type virus at enrollment developed a K65R substitution by week 16, while the second subject had virus expressing the combination of D67N and K70R substitutions upon seroconversion at week 60, although baseline virus was not genotyped and it is unclear if the resistance emerged or was transmitted. Following enrollment, 4 subjects (2 in the VIREAD group, 1 in the TRUVADA group, and 1 in the placebo group) had virus expressing K103N or V106A substitutions, which confer high-level resistance to NNRTIs but have not been associated with tenofovir or emtricitabine and may have been present in the infecting virus.

Cross-resistance

Emtricitabine and tenofovir DF: Cross-resistance among certain nucleoside reverse transcriptase inhibitors (NRTIs) has been recognized. The M184V/I and/or K65R or K70E substitutions selected in vitro by the combination of emtricitabine and tenofovir are also observed in some HIV-1 isolates from subjects failing treatment with tenofovir in combination with either lamivudine or emtricitabine, and either abacavir or didanosine. Therefore, cross-resistance among these drugs may occur in patients whose virus harbors either or both of these amino acid substitutions.

Emtricitabine: Emtricitabine-resistant isolates (M184V/I) were cross-resistant to lamivudine and zalcitabine but retained susceptibility in vitro to didanosine, stavudine, tenofovir, zidovudine, and NNRTIs (delavirdine, efavirenz, and nevirapine). Isolates from heavily treatment-experienced patients containing the M184V/I amino acid substitution in the context of other NRTI resistance-associated substitutions may retain susceptibility to tenofovir. HIV-1 isolates containing the K65R substitution, selected in vivo by abacavir, didanosine, tenofovir, and zalcitabine, demonstrated reduced susceptibility to inhibition by emtricitabine. Viruses harboring mutations conferring reduced susceptibility to stavudine and zidovudine (M41L, D67N, K70R, L210W, T215Y/F, K219Q/E) or didanosine (L74V) remained sensitive to emtricitabine. HIV-1 containing the K103N substitution associated with resistance to NNRTIs was susceptible to emtricitabine.

Tenofovir DF: HIV-1 isolates from patients (N=20) whose HIV-1 expressed a mean of 3 zidovudine-associated RT amino acid substitutions (M41L, D67N, K70R, L210W, T215Y/F, or K219Q/E/N) showed a 3.1-fold decrease in the susceptibility to tenofovir. Multinucleoside resistant HIV-1 with a T69S double insertion mutation in the RT showed reduced susceptibility to tenofovir.

NON-CLINICAL TOXICOLOGY

Toxicology

Tenofovir and tenofovir DF administered in toxicology studies to rats, dogs and monkeys at exposures (based on AUCs) greater than or equal to 6-fold those observed in humans caused bone toxicity. In monkeys the bone toxicity was diagnosed as osteomalacia. Osteomalacia observed in monkeys appeared to be reversible upon dose reduction or discontinuation of tenofovir. In rats and dogs, the bone toxicity manifested as reduced bone mineral density. The mechanism(s) underlying bone toxicity is unknown.

Evidence of renal toxicity was noted in 4 animal species. Increases in serum creatinine, BUN, glycosuria, proteinuria, phosphaturia, and/or calciuria and decreases in serum phosphate were observed to varying degrees in these animals. These toxicities were noted at exposures (based on AUCs) 2–20 times higher than those observed in humans. The relationship of the renal abnormalities, particularly the phosphaturia, to the bone toxicity is not known.

Carcinogenesis

Emtricitabine: In long-term oral carcinogenicity studies of emtricitabine, no drug-related increase in tumor incidence was found in mice at doses up to 750 mg/kg/day (26 times the human systemic exposure at the therapeutic dose of 200 mg/day) or in rats at doses up to 600 mg/kg/day (31 times the human systemic exposure at the therapeutic dose).

Tenofovir DF: Long-term oral carcinogenicity studies were conducted in mice and rats receiving tenofovir DF. At the high dose in female mice, liver adenomas were increased at exposures 16 times that in humans. In the mouse study, (60/sex/group), one male and two female mice in the 600 mg/kg/day group (15 times the human systemic exposure at the recommended human dose of 300 mg/day) developed duodenal tumors. The mechanism underlying this effect is uncertain but may relate to high local drug concentrations in the gastrointestinal tract. No treatment-related tumors were seen in mice in the 100 or 300 mg/kg/day groups. In the rat study (60/sex/group) at doses of 30, 100, and 300 mg/kg/day (approximately 5 times human exposure), no treatment-related increase in tumor incidence was observed.

Mutagenesis

Emtricitabine: Emtricitabine was not genotoxic in the reverse mutation bacterial test (Ames test), mouse lymphoma or mouse micronucleus assays.

Tenofovir DF: Tenofovir DF was negative in the in vitro bacterial mutation (Ames) assay (*Salmonella-Escherichia coli*/Mammalian-Microsome Reverse Mutation Assay) but positive in the in vitro mouse lymphoma assay (L5178Y TK +/- Forward Mutation Assay), with and without metabolic activation. Tenofovir DF was negative in the in vivo mouse micronucleus assay at plasma exposure levels of more than 10× the human exposure.

Impairment of Fertility

Emtricitabine: Emtricitabine did not affect fertility in male rats at approximately 140-fold or in male and female mice at approximately 60-fold higher exposures (AUC) than in humans given the recommended 200 mg daily dose. Fertility was normal in the offspring of mice exposed daily from before birth (in utero) through sexual maturity at daily exposures (AUC) of approximately 60-fold higher than human exposures at the recommended 200 mg daily dose.

Tenofovir DF: Reproductive toxicity was evaluated in rats and rabbits. Tenofovir DF had no adverse effects on fertility or general reproductive performance in rats at doses up to 600 mg/kg/day. Tenofovir DF had no adverse effects on embryo-fetal development in rats at doses 450 mg/kg/day and in rabbits at doses up to 300 mg/kg/day. In a study of effects on peri- and postnatal development in rats, effects considered due to maternal toxicity (450–600 mg/kg/day) were reduced survival and a slight delay in sexual maturation in the F1 generation. There were no adverse effects on growth, development, behavior, or reproductive parameters at non-maternally toxic doses (150 mg/kg/day).

Pregnancy

Emtricitabine: The incidence of fetal variations and malformations was not increased in embryofetal toxicity studies performed with emtricitabine in mice at exposures (AUC) approximately 60-fold higher and in rabbits at approximately 120-fold higher than human exposures at the recommended daily dose.

Tenofovir DF: Reproduction studies have been performed in rats and rabbits at doses up to 14 and 19 times the human dose based on body surface area comparisons and revealed no evidence of impaired fertility or harm to the fetus due to tenofovir. Reduced pup body weights, survival and delay in sexual maturation was observed in a peri- and postnatal toxicity study in rats at the maternally toxic doses of 450 and 600 mg/kg (approximately 14 and 19 times the human dose based on body surface area comparisons).

Antiretroviral Pregnancy Registry

To monitor fetal outcomes of pregnant women exposed to ART (antiretroviral therapy) including TRUVADA, an Antiretroviral Pregnancy Registry has been established. Healthcare providers are encouraged to register patients by calling 800–258–4263.

REFERENCES

1. Deeks SG, Barditch-Crovo P, Lietman PS, Hwang F, Cundy KC, Rooney JF, et al. Safety, pharmacokinetics, and antiretroviral activity of intravenous 9-[2-(R)-(phosphonomethoxy)propyl]adenine, a novel anti-human immunodeficiency virus (HIV) therapy, in HIV-infected adults. *Antimicrob Agents Chemother* 1998 Sep;42 (9):2380-4.
2. Barditch-Crovo P, Deeks SG, Collier A, Safrin S, Coakley DF, Miller M, et al. Phase I/II trial of the pharmacokinetics, safety, and antiretroviral activity of tenofovir disoproxil fumarate in HIV-1 infected adults. *Antimicrob Agents Chemother* 2001 Oct;45 (10):2733-9.
3. Schooley RT, Ruane P, Myers RA, Beall G, Lampiris H, Berger D, et al. Tenofovir DF in antiretroviral-experienced patients: results from a 48-week, randomized, double-blind study. *AIDS* 2002 Jun 14;16 (9):1257-63.
4. Margot NA, Isaacson E, McGowan I, Cheng AK, Schooley RT, Miller MD. Genotypic and phenotypic analyses of HIV-1 in antiretroviral-experienced patients treated with tenofovir DF. *AIDS* 2002 Jun 14;16 (9):1227-35.
5. Gallant, J.E., DeJesus, E., Arribas, J.R., Pozniak, A.L., Gazzard, B., Campo, R.E. et al. Tenofovir DF, Emtricitabine and Efavirenz versus Zidovudine, Lamivudine and Efavirenz for HIV. *New Engl. J. Med.* 2006 (354): 251-260.
6. EMEA Public Statement, Efficacy and safety concerns regarding the co-administration of tenofovir disoproxil fumarate (TDF, Viread) and didanosine (ddI, Videx), 2005. <http://www.emea.eu.int/pdfs/human/press/pus/6233105en.pdf>.
7. Podzamczar D, Ferrer E, Gatell JM, Niubo J, Dalmau D, Leon A, Knobel H, Polo C, Iniguez D, Ruiz I. Early virological failure with a combination of tenofovir, didanosine and efavirenz. *Antiviral Therapy* 2005; 10: 171-177.
8. Benaboud, S., et al. 2011. Concentrations of Tenofovir and Emtricitabine in Breast Milk of HIV-1 Infected Women in Abidjan, Côte d'Ivoire, in the ANRS 12109 TEmAA Study, Step 2. *Antimicrob. Agents Chemother.* 55: 1315-1317.
9. Baeten J, Donnell D, Ndase P, Mugo N, Campbell J, Wangisi J, et al. Antiretroviral prophylaxis for HIV prevention in heterosexual men and women. *N Engl J Med* 2012;367 (5):399-410.
10. Grant RM, Lama JR, Anderson PL, McMahan V, Liu AY, Vargas L, et al. Preexposure Chemoprophylaxis for HIV Prevention in Men Who Have Sex with Men. *N Engl J Med* 2010;363 (27):2587-99.

PART III. CONSUMER INFORMATION

Pr **TRUVADA**[®] (emtricitabine/tenofovir disoproxil fumarate) tablets

This leaflet is Part III of a three part “Product Monograph” published when TRUVADA was approved for sale in Canada and is designed specifically for consumers. This leaflet is a summary and will not tell you everything about TRUVADA. Contact your healthcare professional if you have any questions about the drug.

ABOUT THIS MEDICATION

What the medication is used for:

TRUVADA is a type of medicine called an HIV (human immunodeficiency virus) nucleoside analog reverse transcriptase inhibitor (NRTI). TRUVADA contains 2 medicines, EMTRIVA[®] (emtricitabine) and VIREAD[®] (tenofovir disoproxil fumarate, or tenofovir DF) combined in one pill.

TRUVADA is used:

- **To treat HIV-1 Infection** when used with other anti-HIV medicines in adults.
- OR
- **To help reduce the risk of getting HIV-1 infection** when used with safer sex practices in:
 - HIV-1 negative men who have sex with men, who are at high risk of getting infected with HIV-1 through sex.
 - Male-female sex partners when one partner has HIV-1 infection and the other does not.
- This is sometimes called Pre-Exposure Prophylaxis or PrEP. For more information on TRUVADA for PrEP, log onto www.truvada.ca.
- TRUVADA is for adults age 18 and older. TRUVADA is not indicated in children under age 18 or adults over age 65.

What it does:

- **Use of TRUVADA to treat HIV-1 infection:**
When used with other HIV-1 medicines to treat HIV-1 infection, TRUVADA helps block HIV reverse transcriptase, a chemical in your body (enzyme) that is needed for HIV to multiply. TRUVADA lowers the amount of HIV in the blood (viral load). Lowering the amount of HIV in the blood lowers the chance of infections that happen when your immune system is weak (opportunistic infections).

HIV infection destroys CD4+ (T) cells, which are important to the immune system. The immune system helps fight infection. After a large number of T cells are destroyed, acquired immune deficiency syndrome (AIDS) develops. TRUVADA may also help to increase the number of T cells (CD4+ cells).

TRUVADA does not cure HIV-1 infection or AIDS. If you have HIV-1 infection, you must stay on continuous HIV therapy to control HIV infection and decrease HIV-related illnesses.

People taking TRUVADA may still get opportunistic infections or other conditions that happen with HIV infection. Opportunistic infections are infections that develop because the immune system is weak. Some of these conditions are pneumonia, herpes virus infections, and *Mycobacterium avium* complex (MAC) infections.

- **Use of TRUVADA to reduce the risk of HIV-1 infection (PrEP indication):**
When used with safer sex practices, TRUVADA may help to reduce the risk of getting HIV-1 infection:
 - TRUVADA works better to reduce the risk of getting HIV-1 when the medicines are in your bloodstream **before** you are exposed to HIV-1.

It is very important that you see your healthcare professional regularly while taking TRUVADA.

Considerations when TRUVADA is used for PrEP:

- Together with your healthcare professional, you need to decide whether TRUVADA is right for you.
- TRUVADA can only help reduce your risk of getting HIV-1 **before** you are infected.
- Do not take TRUVADA to help reduce your risk of getting HIV-1 if:
 - you already have HIV-1 infection. If you are HIV-1 positive, you need to take other medicines with TRUVADA to treat HIV-1. TRUVADA by itself is not a complete treatment for HIV-1.
 - you do not know your HIV-1 infection status. You may already be HIV-1 positive. You need to take other HIV-1 medicines with TRUVADA to treat HIV-1.
- Your healthcare professional will run tests to determine that you are HIV- negative before starting PrEP treatment.

When it should not be used:

Do not use TRUVADA if:

- You are allergic (hypersensitive) to any of the ingredients in this formulation (see: **What the medicinal ingredients are; What the important nonmedicinal ingredients are**)
- Do not use TRUVADA to reduce the risk of getting HIV if you already have HIV or do not know your HIV status.

What the medicinal ingredients are:

emtricitabine
tenofovir disoproxil fumarate (tenofovir DF)

What the important nonmedicinal ingredients are:

croscarmellose sodium, lactose monohydrate, magnesium stearate, microcrystalline cellulose, pregelatinized starch, FD&C blue #2, hypromellose, titanium dioxide and triacetin.

What dosage forms it comes in:

TRUVADA is available as tablets. Each tablet contains 200 mg of emtricitabine and 300 mg of tenofovir disoproxil fumarate (which is equivalent to 245 mg of tenofovir disoproxil), as active ingredients. The tablets are blue, capsule-shaped, film-coated, and debossed with “GILEAD” on one side and with “701” on the other side. Each bottle contains 30 tablets and a desiccant (silica gel canister or sachet) and is closed with a child-resistant closure.

WARNINGS AND PRECAUTIONS

Serious Warnings and Precautions

- The most serious possible side effect is harm to the kidneys, including damage to kidney cells, kidney tissue inflammation and kidney failure. Your healthcare professional may monitor your kidney function before beginning and while receiving TRUVADA. Some patients treated with tenofovir DF (a component of TRUVADA) have had kidney problems. Your healthcare professional may need to perform additional blood tests if you have had kidney problems in the past or need to take another drug that can cause kidney problems.
- **If you are also infected with the Hepatitis B Virus, “flare-ups” of Hepatitis B Virus infection**, in which the disease suddenly returns in a worse way than before, can occur if you stop taking TRUVADA. Do not stop taking TRUVADA without your healthcare professional’s advice. If you stop taking TRUVADA, tell your healthcare professional immediately about any new, unusual or worsening symptoms that you notice after stopping treatment. After you stop taking TRUVADA, your healthcare professional will still need to check your health and take blood tests to check your liver for several months. TRUVADA is not approved for the treatment of Hepatitis B Virus infection.
- The class of medicines to which TRUVADA belongs (NRTIs) can cause a condition called lactic acidosis, together with an enlarged liver. Non-specific symptoms such as nausea, vomiting and stomach pain might indicate the development of lactic acidosis. This rare but serious side effect has occasionally been fatal. Lactic acidosis occurs more often in women, particularly if they are very overweight. You should consult your healthcare professional immediately if such symptoms occur while you are receiving TRUVADA. The symptoms that may indicate lactic acidosis include: feeling very weak, tired or uncomfortable; unusual or unexpected stomach discomfort; feeling cold; feeling dizzy or lightheaded; suddenly developing a slow or irregular heartbeat. If you notice these symptoms, stop taking TRUVADA and consult a healthcare professional immediately.
- Tenofovir DF caused harm to the bones of animals. Tenofovir DF reduced bone density in humans. If you notice bone pain, or suffer a bone fracture, or other bone problem, consult your healthcare professional. If you have bone problems, you may wish to discuss calcium and/or vitamin D supplements with your healthcare professionals.

- TRUVADA should only be used for the PrEP indication if you are HIV-negative before and during treatment. Discuss with your healthcare professional if you have had a recent flu-like illness. Your healthcare professional will run tests to confirm that you are HIV negative before and during TRUVADA treatment.

Do NOT take TRUVADA if:

- you are on other medications that may affect your kidneys and have not discussed this with your healthcare professional.
- you have or are at known risk for any type of bone disease or bone related problems and have not discussed this with your healthcare professional.
- you are allergic to TRUVADA or any of its ingredients. The medicinal ingredients are emtricitabine and tenofovir DF (see: **What the important nonmedicinal ingredients are**).
- you are already taking 3TC[®], ATRIPLA[®], Combivir[®], COMPLERA[®], DESCOVY[®], EMTRIVA[®], GENVOYA[®], ODEFSEY[™], Heptovir[®], Kivexa[®], STRIBILD[®], Trumeq[®], Trizivir[®], VEMLIDY[™], or VIREAD[®] because these medicines contain the same or similar active ingredients
- you are also taking HEPSERA[®] to treat your HBV infection

Changes in your immune system (Immune Reconstitution Inflammatory Syndrome) can happen when an HIV-1 infected person starts taking HIV medicines. Your immune system may get stronger and begin to fight infections that have been hidden in your body for a long time, or you could develop an autoimmune disease in which your immune system reacts against your own body [e.g. Grave’s disease (which affects the thyroid gland), Guillain-Barré syndrome (which affects the nervous system) or polymyositis (which affects the muscles)] and it may develop at any time, sometimes months later after the start of HIV therapy. Sometimes symptoms can be severe, so if you develop high temperature (fever), joint or muscle pain, redness, rash, swelling or fatigue, or any new symptoms, contact your healthcare professional right away.

Before taking TRUVADA to reduce your risk of getting HIV-1 infection (PrEP indication):

- **You must get tested to be sure you are HIV-negative.** It is important that you also get tested at least every 3 months as recommended by your healthcare provider while taking TRUVADA. **Do not take TRUVADA to reduce the risk of getting HIV (PrEP) unless you are confirmed to be HIV-negative.**
- Tell your healthcare provider if you have any of the following symptoms within the last month before you start taking TRUVADA or at any time while taking TRUVADA:
 - tiredness
 - fever
 - sweating a lot (especially at night)
 - rash

- vomiting or diarrhea
- joint or muscle aches
- headache
- sore throat
- enlarged lymph nodes in the neck or groin

These may be signs of HIV infection and you may need to have a different kind of test to diagnose HIV. If you are already taking TRUVADA to prevent HIV-1 infection (PrEP), your healthcare provider may tell you to stop taking TRUVADA until an HIV test confirms that you do not have HIV-1 infection. For more information on TRUVADA for PrEP, log onto www.truvada.ca.

Just taking TRUVADA may not keep you from getting HIV. TRUVADA does NOT always prevent HIV.

You must still practice safer sex at all times. Do not have any kind of sex without protection. Always practice safer sex by using a latex or polyurethane condom to lower the chance of sexual contact with semen, vaginal secretions, or blood.

You must also use other prevention methods to keep from getting HIV.

- Know your HIV-1 status and the HIV-1 status of your partners.
- While taking TRUVADA, get tested at least every 3 months for HIV, as recommended by your healthcare provider. Ask your partners to get tested.
- If you think you were exposed to HIV-1, tell your healthcare provider right away. They may want to do more tests to be sure you are still HIV-negative.
- Get tested for other sexually transmitted infections such as syphilis and gonorrhea. These infections make it easier for HIV to infect you.
- Get information and support to help reduce risky sexual behavior.
- Have fewer sex partners.
- Do not miss any doses of TRUVADA. Missing doses may increase your risk of getting HIV-1 infection.

BEFORE you use TRUVADA (emtricitabine/tenofovir DF) talk to your healthcare professional:

If you are pregnant or planning to become pregnant: Pregnant mothers should not take TRUVADA unless specifically directed by the healthcare professional.

If you are a female who is taking TRUVADA to prevent HIV infection (PrEP) and you become pregnant while taking TRUVADA, talk to your healthcare provider about whether you should continue taking TRUVADA.

Pregnancy Registry. There is a pregnancy registry for women who take antiviral medicines during pregnancy. The purpose of this registry is to collect information about the health of you and your baby. Talk to your healthcare provider about how you can

take part in this Antiretroviral Pregnancy Registry.

If you are breastfeeding or planning to breastfeed: Do not breastfeed if you are taking TRUVADA or have HIV. Emtricitabine and tenofovir DF, the two components of TRUVADA, pass to your baby in your breast milk. You should not breastfeed because of the risk of passing HIV to your baby. Talk to your healthcare professional about the best way to feed your baby.

If you have other medical conditions: Let your healthcare professional know if you have other medical conditions, especially liver, bone and kidney problems.

If you are taking other medicines: Some medicines can interact when taken together, including prescription and non-prescription medicines and dietary supplements (see **INTERACTIONS WITH THIS MEDICATION**).

If you are taking didanosine: Taking didanosine and Truvada may cause serious reactions including lactic acidosis (too much acid in the blood), pancreatitis (inflamed pancreas) and nerve damage (neuropathy) (see **INTERACTIONS WITH THIS MEDICATION and SIDE EFFECTS AND WHAT TO DO ABOUT THEM**).

Truvada should not be used with or soon after cidofovir, acyclovir, valacyclovir, ganciclovir, valganciclovir, aminoglycosides, or nonsteroidal anti-inflammatory drugs (NSAIDs), due to potential harm to the kidneys.

It is a good idea to keep a complete list of all the medicines that you take. Make a new list when medicines are added or stopped. Give copies of this list to all of your healthcare providers every time you visit your healthcare professional or fill a prescription.

Other Special Warnings:

Your blood sugar levels (glucose) or levels of fats (lipids) in your blood may increase with HIV treatment. Your doctor may order blood tests for you.

INTERACTIONS WITH THIS MEDICATION

Let your healthcare professional know if you are taking these or any other medications:

- Drugs that contain didanosine (Videx[®], Videx EC[®]). Tenofovir DF (a component of TRUVADA) may increase the amount of Videx in your blood. You may need to be followed more carefully if you are taking TRUVADA and Videx together. Also, the dose of didanosine may need to be reduced.
- Reyataz[®] (atazanavir sulfate), Kaletra[®] (lopinavir/ritonavir), Prezista[®] (darunavir), HARVONI[®] (ledipasvir/sofosbuvir), EPCLUSA[®] (sofosbuvir/velpatasvir) or VOSEVI[™] (sofosbuvir/velpatasvir/voxilaprevir). These medicines may increase the amount of tenofovir DF (a component of TRUVADA) in your blood, which could result in more side effects. You may need to be followed more carefully if you

are taking TRUVADA together with Reyataz, Kaletra, Prezista, HARVONI, EPCLUSA or VOSEVI. TRUVADA may decrease the amount of Reyataz in your blood. If you are taking TRUVADA and Reyataz together, you should also be taking Norvir® (ritonavir).

- Non-steroidal anti-inflammatory drugs.

PROPER USE OF THIS MEDICATION

Stay under a healthcare professional's care when taking TRUVADA. **Do not change your treatment or stop treatment without first talking with your healthcare professional.**

Take TRUVADA exactly as your healthcare professional prescribed it. Follow the directions from your healthcare professional, exactly as written on the label. Set up a dosing schedule and follow it carefully.

When used to treat HIV-1 infection, TRUVADA is always used with other HIV-1 medicines.

If you take TRUVADA to reduce your risk of getting HIV-1:

- you must also use other methods to reduce your risk of getting HIV.
- **take TRUVADA every day**, not just when you think you have been exposed to HIV-1.

Avoid doing things that can increase your risk of getting HIV infection or spreading HIV infection to other people:

- Do not re-use or share needles or other injection equipment.
- Do not share personal items that can have blood or body fluids on them, like toothbrushes and razor blades.
- Do not have any kind of sex without protection. Always practice safer sex by using a latex or polyurethane condom to lower the chance of sexual contact with semen, vagina secretions, or blood.

Ask your healthcare provider if you have any questions on how to prevent getting HIV infection or spreading HIV infection to other people.

When your TRUVADA supply starts to run low, get more from your healthcare professional. This is very important because the amount of virus in your blood may increase if the medicine is stopped for even a short time. The virus may develop resistance to TRUVADA and become harder to treat.

Only take medicine that has been prescribed specifically for you. Do not give TRUVADA to others or take medicine prescribed for someone else.

Do not use if seal over bottle opening is broken or missing.

Usual Adult Dose:

For the treatment of HIV-1 infection:

- The usual dose of TRUVADA is one tablet orally (by

mouth) once a day, in combination with other anti-HIV medicines.

- TRUVADA may be taken with or without a meal.

For prevention of HIV-1 infection (PrEP):

- The usual dose of TRUVADA is one tablet orally (by mouth) once a day.
- TRUVADA may be taken with or without a meal.

Overdosage:

In case of drug overdose, contact your healthcare professional, hospital emergency department or Regional Poison Control Centre, even if there are no symptoms.

Missed Dose:

It is important that you do not miss any doses. If you miss a dose of TRUVADA and it is less than 12 hours from the time you usually take TRUVADA, then take the dose. If more than 12 hours has passed from the time you usually take TRUVADA, then wait until the next scheduled daily dose. **Do not** take more than 1 dose of TRUVADA in a day. **Do not** take 2 doses at the same time. Call your healthcare professional if you are not sure what to do.

SIDE EFFECTS AND WHAT TO DO ABOUT THEM

The most common side effects of TRUVADA are:

- Diarrhea
- Nausea
- Vomiting
- Dizziness
- Headache

Other side effects include:

- Stomach pain
- Indigestion
- Inflammation of the pancreas
- Sleeping problems
- Abnormal dreams
- Weakness
- Pain
- Shortness of breath
- Allergic reaction (including swelling of the face, lips, tongue or throat)
- Rash
- Flatulence (intestinal gas)
- Skin discoloration (small spots or freckles) may also happen with TRUVADA

SERIOUS SIDE EFFECTS, HOW OFTEN THEY HAPPEN AND WHAT TO DO ABOUT THEM		
Symptoms/Effect	Talk with your healthcare professional	
	Only if severe	In all cases
		Stop taking drug and call your healthcare professional

Rare	<p>Effect: Kidney problems</p> <p>Symptoms</p> <ul style="list-style-type: none"> You may have increased or decreased urination as well as increased thirst You may have swelling of your legs and feet You may feel listless and tired 		✓	
Rare	<p>Effect: Lactic acidosis</p> <p>Symptoms</p> <ul style="list-style-type: none"> Feeling very weak or tired Unusual muscle pain Stomach pain with nausea and vomiting Feeling cold, especially in arms and legs Feeling dizzy or lightheaded Fast or irregular heartbeat 		✓ ✓ ✓ ✓ ✓ ✓	
Very Rare	<p>Effect: Hepatotoxicity (severe liver problems) with hepatomegaly (liver enlargement) and steatosis (fat in the liver)</p> <p>Symptoms</p> <ul style="list-style-type: none"> Jaundice (skin or the white part of eyes turns yellow) Urine turns dark Bowel movements (stools) turn light in color Loss of appetite for several days or longer Feeling sick to your stomach (nausea) Lower stomach pain 		✓ ✓ ✓ ✓ ✓ ✓	
Very Rare	<p>Effect: Flare-ups of hepatitis B virus infection following drug discontinuation</p> <p>Symptoms</p> <ul style="list-style-type: none"> Jaundice (skin or the white part of eyes turns yellow) Urine turns dark Bowel movements (stools) turn light in color Loss of appetite for several days or 		✓ ✓ ✓ ✓	

	longer			
	• Feeling sick to your stomach (nausea)		✓	
	• Lower stomach pain		✓	

Lactic acidosis is a medical emergency and must be treated in the hospital. You may be more likely to get lactic acidosis or serious liver problems if you are very overweight (obese) or have been taking nucleoside analog medicines, like TRUVADA, for a long time.

Muscle pain, muscle weakness, bone pain and softening of the bone (infrequently contributing to fractures) have also been reported.

There have been other side effects in patients taking EMTRIVA or VIREAD. *This is not a complete list of side effects.* If you have questions about side effects, ask your healthcare professional. You should report any new or continuing symptoms to your healthcare professional right away. Your healthcare professional may be able to help you manage these side effects.

HOW TO STORE IT

- Keep TRUVADA and all other medications out of reach and sight of children.
- TRUVADA should be stored at 15–30 °C (59–86 °F). It should remain stable until the expiration date printed on the label.
- Do not keep your medicine in places that are too hot or cold.
- Do not keep medicine that is out of date or that you no longer need. If you throw any medicines away, make sure that children will not find them.
- Keep TRUVADA in its original container and keep the container tightly closed.

MORE INFORMATION

This document plus the full Product Monograph, prepared for healthcare professionals, can be found at: www.gilead.ca or by contacting the sponsor, Gilead Sciences Canada, Inc., at: 1- 866-207- 4267

This leaflet was prepared by Gilead Sciences Canada, Inc.

Last revised: July 5, 2018

Gilead Sciences, Inc.
Foster City, CA 94404
USA

Gilead Sciences Canada, Inc.
Mississauga, ON
L5N 2W3

ATRIPLA[®], COMPLERA[®], DESCOVY[®], EMTRIVA[®], GENVOYA[®], HARVONI[®], EPCLUSA[®], ODEFSEY[™], HEPSERA[®], SOVALDI[®], STRIBILD[®], TRUVADA[®], VEMLIDY[™], VIREAD[®] and VOSEVI[™] are trademarks of Gilead Sciences, Inc. or its related companies.

All other trademarks referenced herein are the property of their owners.

© 2017 Gilead Sciences, Inc. All rights reserved.



e133222-GS-017

REPORTING SUSPECTED SIDE EFFECTS

You can report any suspected adverse reactions associated with the use of health products to the Canada Vigilance Program by one of the following 3 ways:

- Report online at www.canada.ca/en/health-canada/services/drugs-health-products/medeffect-canada
- Call toll-free at 1-866-234-2345
- Complete a Canada Vigilance Reporting Form and:
 - Fax toll-free to 1-866-678-6789, or
 - Mail to: Canada Vigilance Program
Health Canada
Postal Locator 1908C
Ottawa, ON K1A 0K9

Postage paid labels, Canada Vigilance Reporting Form and the adverse reaction reporting guidelines are available on the Medeffect[™] Canada Web site at www.canada.ca/en/health-canada/services/drugs-health-products/medeffect-canada.

NOTE: Should you require information related to the management of side effects, contact your health care professional. The Canada Vigilance Program does not provide medical advice.

PRODUCT MONOGRAPH

PrTRUVADA[®]

(emtricitabine/tenofovir disoproxil fumarate) tablets

(200 mg/300 mg)

Antiretroviral Agent

Gilead Sciences, Inc.
Foster City, CA 94404
USA

Date of Revision: July 5, 2018

Gilead Sciences Canada, Inc.
Mississauga L5N 2W3
Canada

www.gilead.ca

Submission Control No.: 215258

TABLE OF CONTENTS

PART I.	HEALTH PROFESSIONAL INFORMATION	3
	SUMMARY PRODUCT INFORMATION	3
	INDICATIONS AND CLINICAL USE	3
	CONTRAINDICATIONS	5
	WARNINGS AND PRECAUTIONS.....	6
	ADVERSE REACTIONS.....	15
	DRUG INTERACTIONS.....	24
	DOSAGE AND ADMINISTRATION.....	36
	OVERDOSAGE	38
	ACTION AND CLINICAL PHARMACOLOGY	39
	STORAGE AND STABILITY.....	41
	SPECIAL HANDLING INSTRUCTIONS	41
	DOSAGE FORMS, COMPOSITION AND PACKAGING	41
PART II.	SCIENTIFIC INFORMATION	43
	PHARMACEUTICAL INFORMATION.....	43
	CLINICAL TRIALS.....	44
	VIROLOGY (MICROBIOLOGY).....	54
	NON-CLINICAL TOXICOLOGY.....	58
	REFERENCES	60
PART III.	CONSUMER INFORMATION	61

PART I. HEALTH PROFESSIONAL INFORMATION

SUMMARY PRODUCT INFORMATION

Route of Administration	Dosage Form / Strength	Clinically Relevant Nonmedicinal Ingredients
Oral	Tablet emtricitabine 200 mg/ tenofovir disoproxil fumarate 300 mg	lactose monohydrate, pregelatinized starch (gluten free)

*For a complete listing, see **Dosage Forms, Composition and Packaging** section.*

TRUVADA[®] tablets are a fixed-dose combination containing emtricitabine (also known as EMTRIVA[®]) and tenofovir disoproxil fumarate (DF) (also known as VIREAD[®]).

INDICATIONS AND CLINICAL USE

Treatment of HIV-1 Infection

TRUVADA is indicated in combination with other antiretroviral agents (such as non-nucleoside reverse transcriptase inhibitors or protease inhibitors) for the treatment of HIV-1 infection in adults.

Additional important information regarding the use of TRUVADA for the treatment of HIV-1 infection:

- It is not recommended that TRUVADA be used as a component of a triple nucleoside regimen.
- TRUVADA should not be coadministered with ATRIPLA[®], COMPLERA[®], DESCOVY[®], EMTRIVA, GENVOYA[®], ODEFSEY[™], STRIBILD[®], VEMLIDY[™], or VIREAD or lamivudine-containing products (see **WARNINGS AND PRECAUTIONS**).
- In treatment-experienced patients, the use of TRUVADA should be guided by laboratory testing and treatment history (see **VIROLOGY**).

Pre-Exposure Prophylaxis (PrEP) of HIV-1 Infection

TRUVADA is indicated in combination with safer sex practices for PrEP to reduce the risk of sexually acquired HIV-1 infection in adults at high risk.

When considering TRUVADA for PrEP, the following factors may help to identify individuals at high risk:

- has partner(s) known to be HIV-1 infected, or

- engages in sexual activity within a high prevalence area or social network and one or more of the following:
 - inconsistent or no condom use
 - diagnosis of sexually transmitted infections
 - exchange of sex for commodities (such as money, food, shelter, or drugs)
 - use of illicit drugs or alcohol dependence
 - incarceration
 - partner(s) of unknown HIV-1 status with any of the factors listed above

When prescribing TRUVADA for PrEP, healthcare providers must:

- prescribe TRUVADA as part of a comprehensive prevention strategy because TRUVADA is not always effective in preventing the acquisition of HIV-1 infection (see **WARNINGS AND PRECAUTIONS**);
- counsel all uninfected individuals to strictly adhere to the recommended TRUVADA dosing schedule because the effectiveness of TRUVADA in reducing the risk of acquiring HIV-1 was strongly correlated with adherence as demonstrated by measurable drug levels in clinical trials (see **WARNINGS AND PRECAUTIONS**);
- confirm a negative HIV-1 test immediately prior to initiating TRUVADA for a PrEP indication. If clinical symptoms consistent with acute viral infection are present and recent (<1 month) exposures are suspected, delay starting PrEP for at least one month and reconfirm HIV-1 status or use a test approved by Health Canada as an aid in the diagnosis of HIV-1 infection, including acute or primary HIV-1 infection (see **WARNINGS AND PRECAUTIONS**); and
- screen for HIV-1 infection at least once every 3 months while taking TRUVADA for PrEP.

This indication is based on clinical trials in men who have sex with men (MSM) at high risk for HIV-1 infection and in heterosexual serodiscordant couples (see **CLINICAL TRIALS**). For more information on TRUVADA for PrEP, log onto www.truvada.ca.

Geriatrics (>65 years of age)

Clinical studies of TRUVADA, EMTRIVA or VIREAD did not include sufficient numbers of subjects aged 65 and over to determine whether they respond differently from younger subjects.

Pediatrics (<18 years of age)

Safety and effectiveness in pediatric patients have not been established.

CONTRAINDICATIONS

TRUVADA is contraindicated in patients with previously demonstrated hypersensitivity to any of the components of the product. For a complete listing, see the **DOSAGE FORMS, COMPOSITION AND PACKAGING** section of the Product Monograph.

TRUVADA is contraindicated for use as PrEP in individuals with unknown or positive HIV-1 status.

WARNINGS AND PRECAUTIONS

Serious Warnings and Precautions

- **Lactic Acidosis and Severe Hepatomegaly with Steatosis**

Lactic acidosis and severe hepatomegaly with steatosis, including fatal cases, have been reported with the use of nucleoside analogs, including tenofovir DF (VIREAD), a component of TRUVADA, alone or in combination with other antiretrovirals (see **WARNINGS AND PRECAUTIONS**).

- **Post-Treatment Exacerbation of Hepatitis B**

TRUVADA is not approved for the treatment of chronic hepatitis B virus (HBV) infection and the safety and efficacy of TRUVADA have not been established in patients co-infected with HBV and HIV. Severe acute exacerbations of hepatitis B have been reported in patients who are co-infected with HBV and HIV and have discontinued TRUVADA. Hepatic function should be monitored closely with both clinical and laboratory follow-up for at least several months in patients who are infected with HBV and discontinue TRUVADA. If appropriate, initiation of anti-hepatitis B therapy may be warranted (see **WARNINGS AND PRECAUTIONS**).

- **Nephrotoxicity**

Renal impairment, including cases of acute renal failure and Fanconi syndrome (renal tubular injury with severe hypophosphatemia) has been reported with the use of TRUVADA during clinical practice (see **WARNINGS AND PRECAUTIONS**).

- **Risk of Drug Resistance with Use of TRUVADA for Pre-Exposure Prophylaxis (PrEP) in Undiagnosed Early HIV-1 Infection**

TRUVADA used for a PrEP indication must only be prescribed to individuals confirmed to be HIV-negative immediately prior to initial use and periodically (at least every 3 months) during use. Drug-resistant HIV-1 variants have been identified with the use of TRUVADA for a PrEP indication following undetected acute HIV-1 infection. Do not initiate TRUVADA for a PrEP indication if signs or symptoms of acute HIV infection are present unless negative infection status is confirmed (see **WARNINGS AND PRECAUTIONS**).

General

TRUVADA should be used in the treatment of HIV-1 infected patients only in combination with other antiretroviral agents.

TRUVADA is a fixed-dose combination of emtricitabine and tenofovir DF. TRUVADA should not be coadministered with other products containing tenofovir DF or emtricitabine (ATRIPLA, COMPLERA, DESCOVY, EMTRIVA, GENVOYA, ODEFSEY, STRIBILD, or VIREAD), or with medicinal products containing tenofovir alafenamide (DESCOVY, GENVOYA, ODEFSEY, and VEMLIDY). Due to similarities between emtricitabine and lamivudine, TRUVADA should not be coadministered with other drugs containing lamivudine (Combivir[®], 3TC[®], Heptovir[®], Kivexa[®], Triumeq[®], or Trizivir[®]).

TRUVADA should not be administered with adefovir dipivoxil (HEPSERA[®]).

Clinical studies in HIV-infected patients have demonstrated that certain regimens that only contain three nucleoside reverse transcriptase inhibitors (NRTI) are generally less effective than triple drug regimens containing two NRTIs in combination with either a non-nucleoside reverse transcriptase inhibitor or a HIV-1 protease inhibitor. In particular, early virological failure and high rates of resistance mutations have been reported. Triple nucleoside regimens should therefore be used with caution. Patients on a therapy utilizing a triple nucleoside-only regimen should be carefully monitored and considered for treatment modification.

Carcinogenesis, Mutagenesis, Impairment of Fertility

Emtricitabine: In long-term oral carcinogenicity studies of emtricitabine, no drug-related increase in tumor incidence was found in mice at doses up to 750 mg/kg/day (26 times the human systemic exposure at the therapeutic dose of 200 mg/day) or in rats at doses up to 600 mg/kg/day (31 times the human systemic exposure at the therapeutic dose).

Emtricitabine was not genotoxic in the reverse mutation bacterial test (Ames test), mouse lymphoma or mouse micronucleus assays.

Emtricitabine did not affect fertility in male rats at approximately 140-fold or in male and female mice at approximately 60-fold higher exposures (AUC) than in humans given the recommended 200 mg daily dose. Fertility was normal in the offspring of mice exposed daily from before birth (in utero) through sexual maturity at daily exposures (AUC) of approximately 60-fold higher than human exposures at the recommended 200 mg daily dose.

Tenofovir DF: Tenofovir DF did not show any carcinogenic potential in a long-term oral carcinogenicity study in rats. A long-term oral carcinogenicity study in mice showed a low incidence of duodenal tumors, considered likely related to high local concentrations in the gastrointestinal tract at the high dose of 600 mg/kg/day. Liver adenomas were also seen at the high dose in female mice. The mechanism of tumor formation in mice and potential relevance for humans are uncertain.

Tenofovir DF was mutagenic in the in vitro mouse lymphoma assay and negative in an in vitro bacterial mutagenicity test (Ames test). In an in vivo mouse micronucleus assay, tenofovir DF was negative at doses up to 2000 mg/kg when administered orally to male mice.

There were no effects on fertility, mating performance or early embryonic development when tenofovir DF was administered at 600 mg/kg/day to male rats for 28 days prior to mating and to female rats for 15 days prior to mating through day seven of gestation. There was, however, an alteration of the estrous cycle in female rats. A dose of 600 mg/kg/day is equivalent to 19 times the human dose based on body surface area comparisons.

Drug Interactions

Use with Certain HCV Regimens

Tenofovir exposure is increased when TRUVADA is coadministered with HARVONI[®] (ledipasvir/sofosbuvir), EPCLUSA[®] (sofosbuvir/velpatasvir), or VOSEVI[™] (sofosbuvir/velpatasvir/voxilaprevir). Patients receiving TRUVADA concomitantly with HARVONI, EPCLUSA or VOSEVI, particularly those at increased risk for renal dysfunction, should be monitored for tenofovir DF-associated adverse reactions (see **DRUG INTERACTIONS**).

Use with Didanosine

Pharmacokinetic studies have shown that coadministration of didanosine and tenofovir DF results in 40-60% increase in C_{max} and AUC of didanosine (see Table 8). The mechanism of this interaction is unknown. Increases in didanosine concentrations of this magnitude could potentiate didanosine-associated adverse events, including pancreatitis, lactic acidosis, and neuropathy. In addition, suppression of CD4 counts has been observed in patients receiving tenofovir DF with didanosine at a dose of 400 mg daily (see **DRUG INTERACTIONS**).

Endocrine and Metabolism

Serum Lipids and Blood Glucose

Serum lipid and blood glucose levels may increase during antiretroviral therapy. Disease control and life style changes may also be contributing factors. Consideration should be given to the measurement of serum lipids and blood glucose. Lipid disorders and blood glucose elevations should be managed as clinically appropriate.

Hepatic/Biliary/Pancreatic

Lactic Acidosis/Severe Hepatomegaly with Steatosis

Lactic acidosis and severe hepatomegaly with steatosis, including fatal cases, have been reported with the use of antiretroviral nucleoside analogs, including tenofovir DF, a component of TRUVADA, alone or in combination with other antiretrovirals in the treatment of HIV infection. A majority of these cases have been in women. Obesity and prolonged nucleoside exposure may be risk factors. Particular caution should be exercised when administering nucleoside analogs to any patient with known risk factors for liver disease; however, cases have also been reported in patients with no known risk factors. Treatment with TRUVADA should be suspended in any patient who develops clinical or laboratory findings suggestive of lactic acidosis or pronounced hepatotoxicity (which may include hepatomegaly and steatosis even in the absence of marked transaminase elevations).

Hepatic Impairment

Tenofovir and tenofovir disoproxil are not metabolized by liver enzymes. Clinically relevant pharmacokinetic changes in patients with hepatic impairment are not observed. Therefore, no dose adjustment is required in patients with hepatic impairment. Emtricitabine has not been evaluated in patients with hepatic impairment; however, emtricitabine has not been shown to be metabolized by liver enzymes, so the impact of liver impairment is likely to be limited. The safety and efficacy of TRUVADA has not been established or specifically studied in patients with underlying liver disorders.

Patients with chronic hepatitis B or C and treated with antiretroviral therapy are at increased risk for severe and potentially fatal hepatic adverse events. In case of concomitant antiviral therapy for hepatitis B or C, please refer also to the relevant product information for these medicinal products.

Hepatitis B Virus Infection

It is recommended that all patients be tested for the presence of hepatitis B virus (HBV) before initiating TRUVADA. TRUVADA is not approved for the treatment of chronic HBV infection and the safety and efficacy of TRUVADA have not been established in patients infected with HBV. Severe acute exacerbations of hepatitis B have been reported in patients who are co-infected with HBV and HIV after the discontinuation of TRUVADA. In some patients infected with HBV and treated with EMTRIVA, the exacerbations of hepatitis B were associated with liver decompensation and liver failure. Hepatic function should be closely monitored with both clinical and laboratory follow up for at least several months in patients who are infected with HBV and discontinue TRUVADA. If appropriate, initiation of anti-hepatitis B therapy may be warranted. In patients with advanced liver disease or cirrhosis, post-treatment exacerbation of hepatitis may lead to hepatic decompensation. Therefore, in these patients, discontinuation of treatment without initiation of alternative anti-hepatitis B therapy is not recommended.

Pancreatitis

Pancreatitis has occurred during therapy with combination regimens that included tenofovir DF (VIREAD). Caution should be used when administering nucleoside analogues (including TRUVADA) to patients with a history of pancreatitis or risk factors for the development of pancreatitis. Therapy should be suspended in patients with suspected pancreatitis.

Immune

Immune Reconstitution Inflammatory Syndrome

Immune reconstitution inflammatory syndrome has been reported in HIV-1 infected patients treated with combination antiretroviral therapy, including the components of TRUVADA. During the initial phase of combination antiretroviral treatment, patients responding to antiretroviral therapy may develop an inflammatory response to indolent or residual opportunistic infections (such as *Mycobacterium avium* infections, cytomegalovirus,

Pneumocystis jiroveci pneumonia (PCP), and tuberculosis), which may necessitate further evaluation and treatment.

Autoimmune disorders (such as Graves' disease, polymyositis and Guillain-Barré syndrome) have also been reported to occur in the setting of immune reconstitution; however, the reported time to onset is more variable, and these events can occur many months after initiation of treatment.

Musculoskeletal

Bone Effects

Bone Mineral Density

In a clinical trial in treatment-naïve HIV-1 infected adults through 144 weeks, decreases from baseline in bone mineral density (BMD) were seen at the lumbar spine and hip in both tenofovir DF and stavudine treatment arms of the study; significantly greater decreases were seen in the lumbar spine measurement in the tenofovir DF group relative to the stavudine group. Clinically relevant fractures were reported in both treatment groups. Increases in biochemical markers of bone metabolism (serum bone-specific alkaline phosphatase, serum osteocalcin, serum C-telopeptide, and urinary N-telopeptide) were observed, suggesting increased bone turnover. Except for bone specific alkaline phosphatase, these changes resulted in values that remained within the normal range. These decreases in BMD and increases in biochemical markers of bone metabolism were also seen in the PrEP trials in HIV-1 uninfected individuals. The effects of tenofovir DF-associated changes in BMD and biochemical markers on long-term bone health and future fracture risk are unknown.

Assessment of BMD should be considered for patients who have a history of pathologic bone fracture or are at risk for osteopenia or osteoporosis. Although the effect of supplementation with calcium and vitamin D was not studied, such supplementation may be beneficial. If bone abnormalities are suspected then appropriate consultation should be obtained.

Mineralization Defects

Cases of hypophosphatemic osteomalacia associated with proximal renal tubulopathy, manifested as bone pain or pain in the extremities and which may contribute to fractures, have been reported in association with the use of tenofovir DF (see **ADVERSE REACTIONS, Post Market Adverse Drug Reactions**). Arthralgias and muscle pain or weakness have also been reported in cases of proximal renal tubulopathy. Hypophosphatemia and osteomalacia secondary to proximal renal tubulopathy should be considered in patients at risk of renal dysfunction who present with persistent or worsening bone or muscle symptoms while receiving products containing tenofovir DF. Serum phosphate should be monitored in these patients.

Renal

Nephrotoxicity

Emtricitabine and tenofovir are principally eliminated by the kidney. Renal impairment, including cases of acute renal failure and Fanconi syndrome (renal tubular injury with severe hypophosphatemia) has been reported in association with the use of tenofovir DF in clinical practice. The majority of these cases occurred in patients with underlying systemic or renal disease, or in patients taking nephrotoxic agents; however, some cases occurred in patients without identified risk factors. Persistent or worsening bone pain, pain in extremities, fractures and/or muscular pain or weakness may be manifestations of proximal renal tubulopathy and should prompt an evaluation of renal function in at-risk patients. It is recommended that creatinine clearance be calculated in all patients prior to initiating therapy and as clinically appropriate during therapy with TRUVADA. In patients at risk of renal dysfunction, including patients who have previously experienced renal events while receiving HEPSERA, it is recommended that calculated creatinine clearance, serum phosphorus, urine glucose, and urine protein be assessed prior to initiation of TRUVADA, and periodically during TRUVADA therapy (see **ADVERSE REACTIONS, Post Market Adverse Drug Reactions and DRUG INTERACTIONS**).

If serum phosphate is < 1.5 mg/dl (0.48 mmol/l) or creatinine clearance is decreased to < 50 ml/min in any patient receiving TRUVADA, renal function should be re-evaluated within one week, including measurements of blood glucose, blood potassium and urine glucose concentrations. Consideration should also be given to interrupting treatment with TRUVADA in patients with creatinine clearance decreased to < 50 ml/min or decreases in serum phosphate to < 1.0 mg/dl (0.32 mmol/l). Interrupting treatment with TRUVADA should also be considered in case of progressive decline of renal function when no other cause has been identified (see **ADVERSE REACTIONS**).

TRUVADA should be avoided with concurrent or recent use of a nephrotoxic agent [eg, cidofovir, acyclovir, valacyclovir, ganciclovir, valganciclovir, aminoglycosides, high-dose or multiple non-steroidal anti-inflammatory drugs (NSAIDs)]. Cases of acute renal failure after initiation of high dose or multiple NSAIDs have been reported in HIV-1 infected patients with risk factors for renal dysfunction who appeared stable on tenofovir DF. Some patients required hospitalization and renal replacement therapy. Alternatives to NSAIDs should be considered, if needed, in patients at risk for renal dysfunction (see **DRUG INTERACTIONS**).

Renal Impairment

Treatment of HIV-1 infection

Dosing interval adjustment of TRUVADA and close monitoring of renal function are recommended in all patients with creatinine clearance 30-49 mL/min. No safety and efficacy data are available in patients with renal dysfunction who received TRUVADA using these guidelines, and so the potential benefit of TRUVADA should be assessed against the potential risk of renal toxicity. TRUVADA should not be administered to patients with

creatinine clearance <30 mL/min or patients requiring hemodialysis (see **DOSAGE AND ADMINISTRATION**).

Pre-exposure Prophylaxis of HIV-1 infection

TRUVADA for a PrEP indication should not be used in HIV-1 uninfected individuals with creatinine clearance below 60 mL/min.

If a decrease in creatinine clearance is observed in uninfected individuals while using TRUVADA for PrEP, evaluate potential causes and re-assess potential risks and benefits of continued use (see **DOSAGE AND ADMINISTRATION**).

Special Populations

Pregnant Women

Antiretroviral Pregnancy Registry: To monitor fetal outcomes of pregnant women exposed to ART (antiretroviral therapy) including TRUVADA, an Antiretroviral Pregnancy Registry has been established. Healthcare providers are encouraged to register patients by calling 800-258-4263.

TRUVADA has been evaluated in a limited number of women during pregnancy and postpartum. Available human and animal data suggest that TRUVADA does not increase the risk of major birth defects overall compared to the background rate. There are, however, no adequate and well-controlled studies in pregnant women. Because animal reproduction studies are not always predictive of human response, TRUVADA should be used in pregnant women only if the potential benefits outweigh the potential risks to the fetus. If an uninfected individual becomes pregnant while taking TRUVADA for a PrEP indication, careful consideration should be given to whether use of TRUVADA should be continued, taking into account the potential increased risk of HIV-1 infection during pregnancy.

As of July 2015, the APR has received prospective reports of 1984 and 2608 exposures to emtricitabine- and tenofovir-containing regimens, respectively in the first trimester; and 949 and 1258 exposures, respectively, in second/third trimester, respectively. Birth defects occurred in 47 of 1984 (2.4%) live births for emtricitabine-containing regimens and 60 of 2608 (2.3%) live births for tenofovir-containing regimens (first trimester exposure); and 20 of 949 (2.1%) live births for emtricitabine-containing regimens and 26 of 1258 (2.1%) live births for tenofovir containing regimens (second/third trimester exposure). Among pregnant women in the U.S. reference population, the background rate of birth defects is 2.7%. There was no association between emtricitabine or tenofovir and overall birth defects observed in the APR.

Emtricitabine: The incidence of fetal variations and malformations was not increased in embryo-fetal toxicity studies performed with emtricitabine in mice at exposures (AUC) approximately 60-fold higher and in rabbits at approximately 120-fold higher than human exposures at the recommended daily dose.

Tenofovir DF: Reproduction studies have been performed in rats and rabbits at doses up to 14 and 19 times the human dose based on body surface area comparisons and revealed no evidence of impaired fertility or harm to the fetus due to tenofovir. Reduced pup body weights, survival and delay in sexual maturation was observed in a peri- and postnatal toxicity study in rats at the maternally toxic doses of 450 and 600 mg/kg (approximately 14 and 19 times the human dose based on body surface area comparisons).

Nursing Women

HIV-infected mothers should not breastfeed their infants to avoid risking postnatal transmission of HIV to the infant.

In humans, samples of breast milk obtained from five HIV-1 infected mothers show that tenofovir is secreted in human milk at low levels (estimated neonatal concentrations 128 to 266 times lower than the tenofovir IC₅₀). Tenofovir-associated risks, including the risk of developing viral resistance to tenofovir, in infants breastfed by mothers being treated with tenofovir DF are unknown.

Samples of breast milk obtained from five HIV-1 infected mothers show that emtricitabine is secreted in human milk at estimated neonatal concentrations 3 to 12 times higher than the emtricitabine IC₅₀ but 3 to 12 times lower than the C_{min} achieved from oral administration of emtricitabine. Breast-feeding infants whose mothers are being treated with emtricitabine may be at risk for developing viral resistance to emtricitabine. Other emtricitabine-associated risks in infants breastfed by mothers being treated with emtricitabine are unknown.

Because of both the potential for HIV transmission and the potential for serious adverse reactions in nursing infants, **mothers should be instructed not to breastfeed if they are receiving TRUVADA**, whether they are taking TRUVADA for treatment or to reduce the risk of acquiring HIV-1.

Pediatrics (<18 years of age)

Safety and effectiveness in pediatric patients have not been established.

Geriatrics (>65 years of age)

Clinical studies of EMTRIVA or VIREAD did not include sufficient numbers of subjects aged 65 and over to determine whether they respond differently than younger subjects. In general, dose selection for the elderly patient should be cautious, keeping in mind the greater frequency of decreased hepatic, renal, or cardiac function, and of concomitant disease or other drug therapy.

PrEP to Reduce the Risk of Acquiring HIV-1 Infection

Comprehensive HIV-1 Infection Prevention Strategy

Use TRUVADA for PrEP only as part of a comprehensive prevention strategy that includes other prevention measures, such as safer sex practices, because TRUVADA is not always effective in preventing the acquisition of HIV-1 (see **CLINICAL TRIALS**).

- Counsel uninfected individuals about safer sex practices that include consistent and correct use of condoms, knowledge of their HIV-1 status and that of their partner(s), and regular testing for other sexually transmitted infections that can facilitate HIV-1 transmission (such as syphilis and gonorrhea).
- Inform uninfected individuals about and support their efforts in reducing sexual risk behavior.

Risk of Resistance

Use TRUVADA to reduce the risk of acquiring HIV-1 only in individuals confirmed to be HIV-negative prior to initiating PrEP and re-confirmed routinely while taking PrEP. HIV-1 resistance substitutions may emerge in individuals with undetected HIV-1 infection who are taking only TRUVADA, **because TRUVADA alone does not constitute a complete treatment regimen for HIV-1 treatment**; therefore, care should be taken to minimize drug exposure in HIV-infected individuals (see **VIROLOGY: Resistance**).

- Many HIV-1 tests, such as rapid tests, detect anti-HIV antibodies and may not identify HIV-1 during the acute stage of infection. Prior to initiating TRUVADA for a PrEP indication, evaluate seronegative individuals for current or recent signs or symptoms consistent with acute viral infections (e.g., fever, fatigue, myalgia, skin rash, etc.) and ask about potential exposure events (e.g., unprotected, or condom broke during sex with an HIV-1 infected partner) that may have occurred within the last month.
- If clinical symptoms consistent with acute viral infection are present and recent (<1 month) exposures are suspected, delay starting PrEP for at least one month and reconfirm HIV-1 negative status or use a test approved by Health Canada as an aid in the diagnosis of HIV-1 infection, including acute or primary HIV-1 infection.
- While using TRUVADA for a PrEP indication, HIV-1 screening tests should be repeated at least every 3 months. If symptoms consistent with acute HIV-1 infection develop following a potential exposure event, PrEP should be discontinued until negative infection status is confirmed using a test approved by Health Canada as an aid in the diagnosis of HIV-1, including acute or primary HIV-1 infection.

Counsel uninfected individuals to strictly adhere to the recommended TRUVADA dosing schedule. The effectiveness of TRUVADA in reducing the risk of acquiring HIV-1 is strongly correlated with adherence as demonstrated by measurable drug levels in clinical trials (see CLINICAL TRIALS). For more information on TRUVADA for PrEP,

log onto www.truvada.ca.

ADVERSE REACTIONS

Clinical Trial Adverse Drug Reactions

Because clinical trials are conducted under very specific conditions the adverse reaction rates observed in the clinical trials may not reflect the rates observed in practice and should not be compared to the rates in the clinical trials of another drug. Adverse drug reaction information from clinical trials is useful for identifying drug-related adverse events and for approximating rates.

Adverse Reactions from Clinical Trials Experience in HIV-1 Infected Subjects

TRUVADA: Four hundred and forty-seven HIV-1 infected patients have received combination therapy with EMTRIVA or VIREAD with either a non-nucleoside reverse transcriptase inhibitor or protease inhibitor for 48 weeks in ongoing clinical studies. Study 934 - Treatment Emergent Adverse Events: Assessment of adverse reactions is based on data from Study 934 in which 511 antiretroviral-naïve patients received either EMTRIVA + VIREAD administered in combination with efavirenz (N=257) or Combivir[®] (lamivudine/zidovudine) administered in combination with efavirenz (N=254). Adverse events observed in this study were generally consistent with those seen in other studies in treatment experienced or treatment-naïve patients (Table 1).

Table 1. Selected Treatment-Emergent Adverse Events (Grades 2–4) Reported in ≥3% in Any Treatment Group in Study 934 (0–48 Weeks)

	EMTRIVA+VIREAD+EFV	AZT/3TC+EFV
	N=257	N=254
Blood and Lymphatic System Disorders		
Anemia	<1%	5%
Gastrointestinal Disorder		
Diarrhea	7%	4%
Nausea	8%	6%
Vomiting	1%	4%
General Disorders and Administration Site Condition		
Fatigue	7%	6%
Infections and Infestations		
Sinusitis	4%	2%
Upper respiratory tract infections	3%	3%
Nasopharyngitis	3%	1%
Nervous System Disorders		
Somnolence	3%	2%
Headache	5%	4%
Dizziness	8%	7%
Psychiatric Disorders		
Depression	4%	7%
Insomnia	4%	5%
Abnormal dreams	4%	3%
Skin and Subcutaneous Tissue Disorders		
Rash	5%	4%

Patients who received treatment up to 144 weeks in Study 934 reported adverse events similar in nature and severity to those reported in the first 48 weeks.

Through 48 weeks, 7 patients in the EMTRIVA + VIREAD group and 5 patients in the lamivudine/zidovudine group experienced a new CDC Class C event (10 and 6 patients, respectively, through 144 weeks). Renal safety assessed by laboratory abnormalities was similar in the two groups and no patient discontinued study drug due to renal events. At

Weeks 48 and 144, total limb fat (as measured by dual-energy x-ray absorptiometry) was significantly less in a subgroup of patients in the lamivudine/zidovudine group compared to the tenofovir/emtricitabine subgroup (see Table 2).

Table 2. Study 934 Total Limb Fat at Week 48 and 144 (Dual-Energy X-Ray Absorptiometry)

	EMTRIVA + VIREAD + EFV	AZT/3TC +EFV
Week 48¹	N=51	N=49
Total Limb Fat (kg) (Mean ± S.D.)	8.9 ±5.4	6.9 ±3.9
Week 144²	N=145	N=124
Total Limb Fat (kg) (Mean ± S.D.)	9.2 ±5.4	6.5 ±4.3

¹P=0.03 for the comparison between arms

²P<0.001 for the comparison between arms

Laboratory Abnormalities: Laboratory Abnormalities observed in this study were generally consistent with those seen in other studies (Table 3).

Table 3. Grade 3/4 Laboratory Abnormalities Reported in ≥1% in Any Treatment Group in Study 934 (0–48 Weeks)

	EMTRIVA+VIREAD+EFV N=257	AZT/3TC+EFV N=254
Any ≥ Grade 3 Laboratory Abnormality	25%	22%
Fasting Cholesterol (>240 mg/dL)	15%	17%
Creatine Kinase (M: >990 U/L) (F: >845 U/L)	7%	6%
Serum Amylase (>175U/L)	7%	3%
Alkaline Phosphatase (>550 U/L)	1%	0%
AST (M: >180 U/L) (F: >170 U/L)	3%	2%
ALT (M: >215 U/L) (F: >170 U/L)	2%	2%

	EMTRIVA+VIREAD+EFV N=257	AZT/3TC+EFV N=254
Hemoglobin (<8.0 mg/dL)	0%	3%
Hyperglycemia (>250 mg/dl)	1%	1%
Hematuria (>75 RBC/HPF)	2%	2%
Neutrophil (>750/mm ³)	3%	4%
Fasting Triglycerides (>750 mg/dL)	4%	2%

Laboratory abnormalities in patients who received treatment up to 144 weeks in Study 934 were consistent with those observed in the first 48 weeks of treatment.

In addition to the events described above for Study 934, other adverse events that occurred in at least 3-5% of patients receiving EMTRIVA or VIREAD with other antiretroviral agents in clinical trials include: anorexia, anxiety, arthralgia, asthenia, increased cough, depressive disorders, dyspepsia, fever, flatulence, myalgia, pain, abdominal pain, back pain, chest pain, paresthesia, peripheral neuropathy (including peripheral neuritis and neuropathy), pneumonia, rhinitis and rash event (including rash, pruritus, maculopapular rash, urticaria, vesiculobullous rash, pustular rash and allergic reaction), sweating and weight loss.

Skin discoloration has been reported with higher frequency among EMTRIVA treated patients. Skin discoloration, mainly manifested by hyperpigmentation on the palms and/or soles was generally mild and asymptomatic and of little clinical significance. The mechanism is unknown.

In addition to the laboratory abnormalities described above for Study 934, Grade 3/4 elevations of bilirubin (>2.5 x ULN), pancreatic amylase (>2.0 x ULN), serum glucose (<40 or >250 mg/dL), serum lipase (>2.0 x ULN), and urine glucose (≥3+) occurred in up to 3% of patients treated with EMTRIVA or VIREAD with other antiretroviral agents in clinical trials.

For more information, please consult the EMTRIVA and VIREAD Product Monographs.

In Study 903 through 144 weeks, decreases from baseline in bone mineral density (BMD) were seen at the lumbar spine and hip in both arms of the study. At Week 144, there was a significantly greater mean percentage decrease from baseline in BMD at the lumbar spine in patients in the tenofovir DF group compared with patients in the stavudine group (see Table 4). In both groups, the majority of the reduction in BMD occurred in the first 24–48 weeks of the study and this reduction was sustained through Week 144. Twenty-eight percent of tenofovir DF-treated patients vs. 21% of the stavudine-treated patients lost at least 5% of BMD at the spine or 7% of BMD at the hip. Clinically relevant fractures (excluding fingers and toes) were reported in 4 patients in the tenofovir DF group and 6 patients in the stavudine group. In addition, there were significant increases in biochemical markers of bone metabolism (serum bone-specific alkaline phosphatase, serum osteocalcin, serum C-

telo peptide, and urinary N-telo peptide) in the tenofovir DF group relative to the stavudine group, suggesting increased bone turnover. Serum parathyroid hormone levels and 1,25 Vitamin D levels were also higher in the tenofovir DF group. Except for bone specific alkaline phosphatase, these changes resulted in values that remained within the normal range. The effects of tenofovir DF-associated changes in BMD and biochemical markers on long-term bone health and future fracture risk are unknown.

Table 4 Changes in Bone Mineral Density Study 903

	Mean Percent Change (\pm SD) to Week 144 in BMD	
	VIREAD + 3TC+ EFV	d4T + 3TC +EFV
Lumbar Spine	-2.2% \pm 3.9	-1.0% \pm 4.6
Hip	-2.8% \pm 3.5	-2.4% \pm 4.5

Adverse Reactions from Clinical Trials Experience in HIV-1 Uninfected Adult Subjects (PrEP)

No new adverse reactions to TRUVADA were identified from two randomized placebo-controlled clinical trials (iPrEx, Partners PrEP) in which 2830 HIV-1 uninfected adults received TRUVADA once daily for pre-exposure prophylaxis. Subjects were followed for a median of 71 weeks and 87 weeks, respectively. These trials enrolled HIV-negative individuals ranging in age from 18 to 67 years. The iPrEx trial enrolled only men or transgender women of Hispanic/Latino (72%), White (18%), Black (9%) and Asian (5%) race. The Partners PrEP trial enrolled both men (61–64% across treatment groups) and women in Kenya and Uganda. Table 5 provides a list of all adverse events that occurred \geq 2% of subjects in any treatment group in the iPrEx and Partners PrEP trials.

Table 5 Selected Adverse Events (All Grades) Reported in $\geq 2\%$ of Uninfected individuals in Any Treatment Group in the iPrEx Trial and Partners PrEP Trial

	iPrEx Trial		Partners PrEP Trial	
	FTC/TDF N=1251	Placebo N=1248	FTC/TDF N=1579	Placebo N=1584
Gastrointestinal Disorder				
Diarrhea	7%	8%	2%	3%
Abdominal pain	4%	2%	- ^a	-
Infections and Infestations				
Pharyngitis	13%	16%	-	-
Urethritis	5%	7%	-	-
Urinary tract infection	2%	2%	5%	7%
Syphilis	6%	5%	-	-
Secondary syphilis	6%	4%	-	-
Anogenital warts	2%	3%	-	-
Musculoskeletal and Connective Tissue Disorders				
Back pain	5%	5%	-	-
Nervous System Disorders				
Headache	7%	6%	-	-
Psychiatric Disorders				
Depression	6%	7%	-	-
Anxiety	3%	3%	-	-
Reproductive System and Breast Disorders				
Genital ulceration	2%	2%	2%	2%
Investigations				
Weight decreased	3%	2%	-	-

a. Not reported or reported below 2%.

Laboratory Abnormalities: Table 6 provides a list of laboratory abnormalities observed in both PrEP trials. Six subjects in the TDF-containing arms of the Partners PrEP trial discontinued participation in the study due to an increase in blood creatinine compared with no discontinuations in the placebo group. One subject in the TRUVADA arm of the iPrEx trial discontinued from the study due to an increase in blood creatinine and another due to low phosphorus.

Table 6 Laboratory Abnormalities (Highest Toxicity Grade) Reported for Each Subject in the iPrEx Trial and Partners PrEP Trial

	Grade ^b	iPrEx Trial		Partners PrEP Trial	
		FTC/TDF N=1251	Placebo N=1248	FTC/TDF N=1579	Placebo N=1584
Creatinine	1 (1.1-1.3 X ULN)	27 (2%)	21 (2%)	18 (1%)	12 (<1%)
	2-4 (> 1.4 x ULN)	5 (<1%)	3 (<1%)	2 (<1%)	1 (<1%)
Phosphorus	1 (2.5 - <LLN mg/dL)	81 (7%)	110 (9%)	NR ^a	NR ^a
	2-4 (<2.0 mg/dL)	123 (10%)	101 (8%)	140 (9%)	136 (9%)
AST	1 (1.25-<2.5 x ULN)	175 (14%)	175 (14%)	20 (1%)	25 (2%)
	2-4 (> 2.6 x ULN)	57 (5%)	61 (5%)	10 (<1%)	4 (<1%)
ALT	1 (1.25-<2.5 x ULN)	178 (14%)	194 (16%)	21 (1%)	13 (<1%)
	2-4 (> 2.6 x ULN)	84 (7%)	82 (7%)	4 (<1%)	6 (<1%)
Hemoglobin	1 (8.5 - 10 mg/dL)	49 (4%)	62 (5%)	56 (4%)	39 (2%)
	2-4 (<9.4 mg/dL)	13 (1%)	19 (2%)	28 (2%)	39 (2%)
Neutrophils	1 (1000-1300/mm ³)	23 (2%)	25 (2%)	208 (13%)	163 (10%)
	2-4 (<750/mm ³)	7 (<1%)	7 (<1%)	73 (5%)	56 (3%)

- a. Grade 1 phosphorus was not reported for the Partners PrEP trial.
b. Grading is per DAIDS criteria.

In addition to the laboratory abnormalities described above, Grade 1 proteinuria (1+) occurred in 6% of subjects receiving TRUVADA in the iPrEx trial. Grade 2-3 proteinuria (2-4+) and glycosuria (3+) occurred in less than 1% of subjects treated with TRUVADA in the iPrEx trial and Partners PrEP trial.

In clinical trials of HIV-1 uninfected individuals, decreases in BMD were observed. In the iPrEx trial, a substudy of 503 subjects found mean changes from baseline in BMD ranging from -0.4% to -1.0% across total hip, spine, femoral neck, and trochanter in the TRUVADA group compared with the placebo group, which returned toward baseline after discontinuation of treatment. Thirteen percent of subjects receiving TRUVADA vs. 6% of subjects receiving placebo lost at least 5% of BMD at the spine during treatment. Bone fractures were reported in 1.7% of the TRUVADA group compared with 1.4% in the placebo group. No correlation between BMD and fractures was noted. The Partners PrEP trial found similar fracture rates between treatment and placebo groups (0.8% and 0.6%, respectively). No BMD evaluations were conducted during this trial (see **CLINICAL TRIALS**).

Post Market Adverse Drug Reactions

Emtricitabine: The following adverse experiences have been reported in post-marketing experience without regard to causality. Because these events are voluntarily reported from a population of unknown size, estimates of frequency cannot be made. These events have been considered possible adverse reactions due to a combination of their seriousness, frequency of reporting or potential causal relationship with treatment.

<i>Blood and lymphatic system disorders:</i>	Thrombocytopenia
<i>Gastrointestinal disorders:</i>	Pancreatitis
<i>General disorders and administrative site conditions:</i>	Pyrexia
<i>Metabolism and nutrition disorders:</i>	Lactic acidosis

Tenofovir DF: The following adverse reactions have been identified during post-approval use of VIREAD. Because these events have been reported voluntarily from a population of unknown size, estimates of frequency cannot be made. These events have been considered possible adverse reactions due to a combination of their seriousness, frequency of reporting or potential causal relationship with tenofovir DF.

<i>Immune system disorders:</i>	Allergic reaction (including angioedema)
<i>Metabolism and nutrition disorders:</i>	Lactic acidosis, hypokalemia, hypophosphatemia,
<i>Respiratory, thoracic and mediastinal disorders:</i>	Dyspnea
<i>Gastrointestinal disorders:</i>	Pancreatitis, increased amylase, abdominal pain
<i>Blood and lymphatic system disorders:</i>	Thrombocytopenia
<i>Hepatobiliary disorders:</i>	Hepatic steatosis, hepatitis, increased liver enzymes (most commonly AST, ALT, GGT)
<i>Skin and Subcutaneous Tissue Disorders:</i>	Rash
<i>Musculoskeletal and Connective Tissue Disorders:</i>	Rhabdomyolysis, osteomalacia (manifested as bone pain and infrequently contributing to fractures), muscular weakness, myopathy
<i>Renal and urinary disorders:</i>	Acute renal failure, renal failure, acute tubular necrosis, Fanconi syndrome, proximal renal tubulopathy, interstitial nephritis (including acute cases), nephrogenic diabetes insipidus, renal insufficiency, increased creatinine,

	proteinuria, polyuria
<i>General Disorders and Administration Site Conditions</i>	Asthenia

The following adverse reactions, listed under the body system headings above, may occur as a consequence of proximal renal tubulopathy: rhabdomyolysis, osteomalacia (manifested as bone pain and infrequently contributing to fractures), hypokalemia, muscular weakness, myopathy, hypophosphatemia.

There have been three post marketing reports of acute renal failure in patients on concomitant NSAIDS therapy where a relationship to tenofovir DF could not be excluded. These events mostly occurred in medically complex patients, where underlying disease processes confound interpretation.

Emtricitabine and Tenofovir DF: In HIV-infected patients with severe immune deficiency at the time of initiation of antiretroviral therapy an inflammatory reaction to infectious pathogens (active or inactive) may arise (see **WARNINGS AND PRECAUTIONS**).

In HIV infected patients coinfecting with HBV, clinical and laboratory evidence of exacerbations of hepatitis has occurred after discontinuation of treatment (see **WARNINGS AND PRECAUTIONS**).

DRUG INTERACTIONS

Overview

Drug interaction studies have been conducted with either TRUVADA, or the components of TRUVADA (emtricitabine and tenofovir DF) as individual agents and/or in combination.

The steady state pharmacokinetics of emtricitabine and tenofovir were unaffected when emtricitabine and tenofovir DF were administered together versus each agent dosed alone (see Table 9 and Table 10).

In vitro and clinical pharmacokinetic drug-drug interaction studies have shown that the potential for CYP450 mediated interactions involving emtricitabine and tenofovir with other medicinal products is low.

Drug-Drug Interactions

Established and Other Potentially Significant Drug Interactions

The drug interactions described are based on studies conducted with the individual agents of TRUVADA and/or in combination, or are potential drug interactions that may occur with TRUVADA.

Table 7. Established and Other Potentially Significant^a Drug Interactions

Concomitant Drug Class: Drug Name	Effect on Concentration ^b	Clinical Comment
Antiretroviral Agents:		
Didanosine	↑ didanosine	<p>Pharmacokinetic studies have shown that coadministration of didanosine and tenofovir DF results in 40-60% increase in C_{max} and AUC of didanosine (see Table 8). The mechanism of this interaction is unknown. Increases in didanosine concentrations of this magnitude could potentiate didanosine-associated adverse events, including pancreatitis, lactic acidosis, and neuropathy. In addition, suppression of CD4 counts has been observed in patients receiving tenofovir DF with didanosine at a dose of 400 mg daily.</p> <p>A reduced dose of Videx EC[®] (ddI-EC) is recommended when coadministered with TRUVADA. When coadministered with TRUVADA, the Videx EC[®] Product Monograph recommends a reduced dose of 250 mg ddI-EC for HIV infected adults with body weight ≥ 60 kg and creatinine clearance ≥ 60 mL/min. For patients with body weight < 60 kg, and creatinine clearance ≥ 60 mL/min, the recommended dose of ddI-EC is 200 mg. Data are not available to recommend a dose adjustment for patients with creatinine clearance < 60 mL/min or for the buffered tablet formulation of didanosine (Videx[®]).</p> <p>Caution should be used when coadministering reduced-dose didanosine, tenofovir, and an NNRTI in treatment-naïve patients</p>

Concomitant Drug Class: Drug Name	Effect on Concentration ^b	Clinical Comment
		with high viral loads at baseline since such use has been associated with reports of a high rate of virologic failure and emergence of resistance at an early stage. All patients receiving tenofovir DF and didanosine concomitantly should be closely monitored for didanosine-related adverse events and clinical response.
Atazanavir/ritonavir Darunavir/ritonavir Lopinavir/ritonavir	↑ tenofovir	Atazanavir/ritonavir, darunavir/ritonavir and lopinavir/ritonavir have been shown to increase tenofovir concentrations (see Table 11). The mechanism of this interaction is unknown. Higher tenofovir concentrations could potentiate tenofovir-associated adverse events, including renal disorders. Patients receiving atazanavir/ritonavir, darunavir/ritonavir or lopinavir/ritonavir and TRUVADA should be monitored for TRUVADA-associated adverse events.
Atazanavir	↓ atazanavir	Tenofovir decreases atazanavir concentrations (see Table 12). Although safety and efficacy data are limited, it is recommended that atazanavir, without ritonavir, should not be coadministered with TRUVADA. The recommended regimen is atazanavir 300 mg given with ritonavir 100 mg when used in combination with TRUVADA (all as a single daily dose with food).

Hepatitis C Virus Antiviral Agents:

Ledipasvir/sofosbuvir Sofosbuvir/velpatasvir Sofosbuvir/velpatasvir/ voxilaprevir	↑ tenofovir	Coadministration of tenofovir DF and HARVONI (ledipasvir/sofosbuvir), EPCLUSA (sofosbuvir/velpatasvir), or VOSEVI (sofosbuvir/velpatasvir/voxilaprevir) has been shown to increase tenofovir exposure (see Table 11). Patients receiving a regimen containing tenofovir DF concomitantly with HARVONI, EPCLUSA, or VOSEVI should be monitored for adverse reactions associated with tenofovir DF (see WARNINGS AND PRECAUTIONS, Drug Interactions).
--	-------------	---

a This table is not all inclusive.

b ↑ = increase, ↓ = decrease

Drugs Affecting Renal Function

Emtricitabine and tenofovir are primarily excreted by the kidneys by a combination of glomerular filtration and active tubular secretion. No drug-drug interactions due to competition for renal excretion have been observed. Since emtricitabine and tenofovir are primarily eliminated by the kidneys, coadministration of TRUVADA with drugs that reduce renal function or compete for active tubular secretion may increase serum concentrations of emtricitabine, tenofovir, and/or other renally eliminated drugs. Some examples include, but are not limited to, acyclovir, valacyclovir, ganciclovir, valganciclovir, aminoglycosides and high-dose or multiple NSAIDs.

TRUVADA should not be administered with HEPSERA (adefovir dipivoxil) (see **WARNINGS AND PRECAUTIONS, General**).

Drugs without Clinically Significant Interactions with TRUVADA

No clinically significant drug interactions have been observed between emtricitabine and famciclovir, indinavir, zidovudine, stavudine, tenofovir DF, sofosbuvir, ledipasvir/sofosbuvir, sofosbuvir/velpatasvir, and sofosbuvir/velpatasvir/voxilaprevir (see Table 9 and Table 10). Similarly, no clinically significant drug interactions have been observed between tenofovir DF and abacavir, efavirenz, emtricitabine, entecavir, indinavir, lamivudine, methadone, nelfinavir, oral contraceptives, ribavirin, saquinavir/ritonavir, sofosbuvir and tacrolimus in studies conducted in healthy volunteers (see Table 11 and Table 12).

Assessment of Drug Interactions

Drug-drug interaction studies were conducted with either TRUVADA, or the components of TRUVADA (emtricitabine or tenofovir DF) as individual agents and/or in combination.

The effects of didanosine in the presence of tenofovir are shown in Table 8.

The effects of coadministered drugs on the exposure of emtricitabine are shown in Table 9. The effects of emtricitabine on the exposure of coadministered drugs are shown in Table 10.

The effects of coadministered drugs on the exposure of tenofovir DF are shown in Table 11. The effects of tenofovir DF on the exposure of coadministered drugs are shown in Table 12.

Table 8 Drug Interactions: Pharmacokinetic Parameters for Didanosine in the Presence of Tenofovir

Didanosine ¹ Dose (mg)/ Method of Administration ²	Tenofovir Method of Administration ²	N	% Difference (90% CI) vs. Didanosine 400 mg Alone, Fasted ³	
			C _{max}	AUC
Buffered tablets				
400 once daily ⁴ × 7 days	Fasted 1 hour after didanosine	14	↑ 27 (↑ 8 to ↑ 46)	↑ 43 (↑ 30 to ↑ 57)
Enteric coated capsules				
400 once, fasted	With food, 2 hr after didanosine	26	↑ 48 (↑ 25 to ↑ 76)	↑ 48 (↑ 31 to ↑ 67)
400 once, with food	Simultaneously with didanosine	26	↑ 64 (↑ 41 to ↑ 89)	↑ 60 (↑ 44 to ↑ 79)
250 once, fasted	With food, 2 hr after didanosine	28	↓ 10 (↓ 22 to ↑ 3)	0 (↓ 11 to ↑ 12)
250 once, fasted	Simultaneously with didanosine	28	↓ 8 (↓ 19 to ↑ 5)	↑ 14 (0 to ↑ 31)
250 once, with food	Simultaneously with didanosine	28	↓ 29 (↓ 39 to ↓ 18)	↓ 11 (↓ 23 to ↑ 2)

1. See **PRECAUTIONS** regarding use of didanosine with VIREAD.
2. Administration with food was with a light meal (~373 kcal, 20% fat).
3. Increase = ↑; Decrease = ↓
4. Includes 4 subjects weighing <60 kg receiving ddi 250 mg.

Table 9 Drug Interactions: Changes in Pharmacokinetic Parameters for Emtricitabine in the Presence of the Coadministered Drug¹

Coadministered Drug	Dose of Coadministered Drug (mg)	Emtricitabine Dose (mg)	N	% Change of Emtricitabine Pharmacokinetic Parameters ² (90% CI)		
				C _{max}	AUC	C _{min}
Tenofovir DF	300 once daily × 7 days	200 once daily × 7 days	17	↓ 4 (↓ 13 to ↑ 6)	↑ 7 (0 to ↑ 4)	↑ 20 (↑ 12 to ↑ 29)
Zidovudine	300 twice daily × 7 days	200 once daily × 7 days	27	↓ 3 (↓ 10 to ↑ 4)	↓ 3 (↓ 7 to ↑ 1)	↓ 4 (↓ 12 to ↑ 4)
Indinavir	800 × 1	200 × 1	12	↓ 8 (↓ 18 to ↑ 4)	↑ 1 (↓ 6 to ↑ 9)	NC
Famciclovir	500 × 1	200 × 1	12	↓ 10 (↓ 20 to ↑ 1)	↓ 8 (↓ 14 to ↓ 1)	NC
Stavudine	40 × 1	200 × 1	6	↑ 4 (↓ 6 to ↑ 16)	↑ 2 (↓ 6 to ↑ 11)	NC

1. All interaction studies conducted in healthy volunteers.
2. ↑ = Increase; ↓ = Decrease; NC= Not Calculated

Table 10 Drug Interactions: Changes in Pharmacokinetic Parameters for Coadministered Drug in the Presence of Emtricitabine¹

Coadministered Drug	Dose of Coadministered Drug (mg)	Emtricitabine Dose (mg)	N	% Change of Coadministered Drug Pharmacokinetic Parameters ² (90% CI)		
				C _{max}	AUC	C _{min}
Tenofovir DF	300 once daily × 7 days	200 once daily × 7 days	17	↑ 3 (↓ 5 to ↑ 11)	0 (↓ 8 to ↑ 9)	↑ 2 (↓ 8 to ↑ 13)
Zidovudine	300 twice daily × 7 days	200 once daily × 7 days	27	↑ 17 (0 to ↑ 38)	↑ 13 (↑ 5 to ↑ 20)	↓ 2 (↓ 11 to ↑ 9)
Indinavir	800 × 1	200 × 1	12	↓ 2 (↓ 16 to ↑ 13)	↑ 2 (↓ 11 to ↑ 17)	NC
Famciclovir	500 × 1	200 × 1	12	↓ 7 (↓ 22 to ↑ 11)	↓ 9 (↓ 17 to ↓ 1)	NC
Stavudine	40 × 1	200 × 1	6	↑ 5 (↓ 5 to ↑ 16)	↑ 9 (↓ 17 to ↑ 44)	NC

1. All interaction studies conducted in healthy volunteers.
2. ↑ = Increase; ↓ = Decrease; NC=Not Calculated

Table 11 Drug Interactions: Changes in Pharmacokinetic Parameters for Tenofovir¹ in the Presence of the Coadministered Drug

Coadministered Drug	Dose of Coadministered Drug (mg)	N	% Change of Tenofovir Pharmacokinetic Parameters ² (90% CI)		
			C _{max}	AUC	C _{min}
Abacavir	300 single dose	8	↓ 8 (↓ 24 to ↑ 12)	↑ 4 (↓ 14 to ↑ 26)	NC
Atazanavir ³	400 once daily × 14 days	33	↑ 14 (↑ 8 to ↑ 20)	↑ 24 (↑ 21 to ↑ 28)	↑ 22 (↑ 15 to ↑ 30)
Atazanavir/ Ritonavir ³	300/100 once daily	12	↑ 34 (↑ 20 to ↑ 51)	↑ 37 (↑ 30 to ↑ 45)	↑ 29 (↑ 21 to ↑ 36)
Darunavir/ Ritonavir ⁴	300/100 twice daily	12	↑ 24 (↑ 8 to ↑ 42)	↑ 22 (↑ 10 to ↑ 35)	↑ 37 (↑ 19 to ↑ 57)
Didanosine (enteric-coated)	400 single dose	25	↓ 2 (↓ 7 to ↑ 4)	↑ 2 (↓ 2 to ↑ 5)	NC
Didanosine (buffered)	250 or 400 once daily × 7 days ⁵	14	↑ 1 (↓ 12 to ↑ 14)	↓ 5 (↓ 14 to ↑ 4)	↓ 22 (↓ 36 to ↓ 7)
Efavirenz	600 once daily × 14 days	29	↑ 7 (↓ 4 to ↑ 17)	↓ 2 (↓ 8 to ↑ 3)	↑ 2 (↓ 9 to ↑ 12)
Emtricitabine	200 once daily × 7 days	17	↑ 3 (↓ 5 to ↑ 11)	0 (↓ 8 to ↑ 9)	↑ 2 (↓ 8 to ↑ 13)
Entecavir	1 mg once daily × 10 days	28	NA	NA	NA
Indinavir	800 three times daily × 7 days	13	↑ 14 (↓ 3 to ↑ 31)	↑ 7 (↓ 5 to ↑ 19)	↑ 8 (↓ 7 to ↑ 22)
Lamivudine	150 twice daily × 7 days	15	↑ 2 (↓ 4 to ↑ 9)	↓ 3 (↓ 15 to ↑ 10)	↓ 8 (↓ 33 to ↑ 18)
Ledipasvir/ Sofosbuvir ^{6,7}	90/400 once daily x10 days	24	↑ 47 (↑ 37 to ↑ 58)	↑ 35 (↑ 29 to ↑ 42)	↑ 47 (↑ 38 to ↑ 57)
Ledipasvir/ Sofosbuvir ^{6,8}		23	↑ 64 (↑ 54 to ↑ 74)	↑ 50 (↑ 42 to ↑ 59)	↑ 59 (↑ 49 to ↑ 70)
Ledipasvir/ Sofosbuvir ⁹		15	↑ 79 (↑ 56 to ↑ 104)	↑ 98 (↑ 77 to ↑ 123)	↑ 163 (↑ 132 to ↑ 197)
Ledipasvir/ Sofosbuvir ¹⁰		14	↑ 32 (↑ 25 to ↑ 39)	↑ 40 (↑ 31 to ↑ 50)	↑ 91 (↑ 74 to ↑ 110)
Ledipasvir/ Sofosbuvir ¹¹		29	↑ 61 (↑ 51 to ↑ 72)	↑ 65 (↑ 59 to ↑ 71)	↑ 115 (↑ 105 to ↑ 126)

Coadministered Drug	Dose of Coadministered Drug (mg)	N	% Change of Tenofovir Pharmacokinetic Parameters ² (90% CI)		
			C _{max}	AUC	C _{min}
Lopinavir/ Ritonavir	400/100 twice daily × 14 days	24	↓ 33 (↓ 17 to ↑ 49)	↑ 32 (↑ 25 to ↑ 40)	↑ 28 (↑ 7 to ↑ 49)
Nelfinavir	1250 twice daily × 14 days	29	↓ 2 (↓ 9 to ↑ 5)	↑ 1 (↓ 5 to ↑ 7)	↑ 9 (↑ 2 to ↑ 17)
Saquinavir/Ritonavir	1000/100 twice daily × 14 days	35	↑ 15 (↑ 7 to ↑ 22)	↑ 14 (↑ 9 to ↑ 19)	↑ 23 (↑ 16 to ↑ 30)
Sofosbuvir ¹²	400 single dose	16	↑ 25 (↑ 8 to ↑ 45)	↓ 2 (↓ 9 to ↑ 5)	↓ 1 (↓ 9 to ↑ 7)
Sofosbuvir/Velpatasvir ¹³	400/100 once daily	24	↑ 55 (↑ 43 to ↑ 68)	↑ 30 (↑ 24 to ↑ 36)	↑ 39 (↑ 31 to ↑ 48)
Sofosbuvir/Velpatasvir ¹⁴		29	↑ 55 (↑ 45 to ↑ 66)	↑ 39 (↑ 33 to ↑ 44)	↑ 52 (↑ 45 to ↑ 59)
Sofosbuvir/Velpatasvir ¹⁵		15	↑ 77 (↑ 53 to ↑ 104)	↑ 81 (↑ 68 to ↑ 94)	↑ 121 (↑ 100 to ↑ 143)
Sofosbuvir/Velpatasvir ¹⁶		24	↑ 44 (↑ 33 to ↑ 55)	↑ 40 (↑ 34 to ↑ 46)	↑ 84 (↑ 76 to ↑ 92)
Sofosbuvir/Velpatasvir ¹⁷		24	↑ 36 (↑ 25 to ↑ 47)	↑ 35 (↑ 29 to ↑ 42)	↑ 45 (↑ 39 to ↑ 51)
Sofosbuvir/Velpatasvir ¹⁸		30	↑ 46 (↑ 39 to ↑ 54)	↑ 40 (↑ 34 to ↑ 45)	↑ 70 (↑ 61 to ↑ 79)
Sofosbuvir/Velpatasvir/Voxilaprevir ¹⁹	400/100/100 + 100 voxilaprevir ²⁰ once daily	29	↑ 48 (↑ 36 to ↑ 61)	↑ 39 (↑ 32 to ↑ 46)	↑ 47 (↑ 38 to ↑ 56)
Tacrolimus	0.05 mg/kg twice daily × 7 days	21	↑ 13 (↑ 1 to ↑ 27)	↑ 6 (↓ 1 to ↑ 13)	↑ 11 (↑ 4 to ↑ 18)
Tipranavir/Ritonavir ²¹	500/100 twice daily	22	↓ 23 (↓ 32 to ↓ 13)	↓ 2 (↓ 9 to ↑ 5)	↑ 7 (↓ 2 to ↑ 17)
	750/200 twice daily (23 doses)	20	↓ 38 (↓ 46 to ↓ 29)	↑ 2 (↓ 6 to ↑ 10)	↑ 14 (↑ 1 to ↑ 27)

1. Patients received VIREAD 300 mg once daily.
2. Increase = ↑; Decrease = ↓; NC = Not Calculated; NA = Not Available
3. Reyataz® Prescribing Information (Bristol-Myers Squibb)
4. Prezista® Prescribing Information
5. weight <60kg: 250 mg, ≥60 kg more: 400 mg
6. Data generated from simultaneous dosing with HARVONI (ledipasvir/sofosbuvir). Staggered administration (12 hours apart) provided similar results.

7. Comparison based on exposures when administered as atazanavir/ritonavir + TRUVADA coadministered with HARVONI.
8. Comparison based on exposures when administered as darunavir/ritonavir + TRUVADA coadministered with HARVONI.
9. Study conducted with ATRIPLA (efavirenz/emtricitabine/tenofovir DF) coadministered with HARVONI.
10. Study conducted with COMPLERA (emtricitabine/rilpivirine/tenofovir DF) coadministered with HARVONI.
11. Study conducted with TRUVADA (emtricitabine/tenofovir DF) + dolutegravir coadministered with HARVONI.
12. Study conducted with ATRIPLA coadministered with SOVALDI[®] (sofosbuvir).
13. Comparison based on exposures when administered as atazanavir/ritonavir + TRUVADA coadministered with EPCLUSA (sofosbuvir/velpatasvir).
14. Comparison based on exposures when administered as darunavir/ritonavir + TRUVADA coadministered with EPCLUSA.
15. Study conducted with ATRIPLA (efavirenz/emtricitabine/tenofovir DF) coadministered with EPCLUSA.
16. Study conducted with COMPLERA (emtricitabine/rilpivirine/tenofovir DF) coadministered with EPCLUSA.
17. Study conducted with STRIBILD (elvitegravir/cobicistat/emtricitabine/tenofovir DF) coadministered with EPCLUSA.
18. Administered as raltegravir + TRUVADA coadministered with EPCLUSA.
19. Comparison based on exposures when administered as darunavir + ritonavir + TRUVADA coadministered with VOSEVI.
20. Study conducted with additional voxilaprevir 100 mg to achieve voxilaprevir exposures expected in HCV-infected patients.
21. Aptivus[®] Prescribing Information.

Table 12 Drug Interactions: Changes in Pharmacokinetic Parameters for Coadministered Drug in the Presence of Tenofovir

Coadministered Drug	Dose of Coadministered Drug (mg)	N	% Change of Coadministered Drug Pharmacokinetic Parameters ¹ (90% CI)		
			C _{max}	AUC	C _{min}
Abacavir ²	300 single dose	8	↑ 12 (↓ 1 to ↑ 26)	↑ 11 (↑ 4 to ↑ 19)	NC
Atazanavir ³	400 once daily × 14 days	34	↓ 21 (↓ 27 to ↓ 14)	↓ 25 (↓ 30 to ↓ 19)	↓ 40 (↓ 48 to ↓ 32)
Atazanavir ³	Atazanavir/Ritonavir 300/100 once daily × 42 days	10	↓ 28 (↓ 50 to ↑ 5)	↓ 25 ⁷ (↓ 42 to ↓ 3)	↓ 23 ⁷ (↓ 46 to ↑ 10)
Darunavir ⁴	Darunavir/Ritonavir 300/100 once daily	12	↑ 16 (↓ 6 to ↑ 42)	↑ 21 (↓ 5 to ↑ 54)	↑ 24 (↓ 10 to ↑ 69)
Didanosine ² (enteric-coated)	250 once, simultaneously with tenofovir DF and a light meal ⁵	33	↓ 29 ⁶ (↓ 39 to ↓ 18)	↓ 11 (↓ 23 to ↑ 2) ⁶	NC
Efavirenz ²	600 once daily × 14 days	30	↓ 4 (↓ 9 to ↑ 1)	↓ 3 (↓ 7 to 0)	↓ 7 (↓ 13 to ↓ 1)
Emtricitabine ²	200 once daily × 7 days	17	↓ 4 (↓ 13 to ↑ 6)	↑ 7 (0 to ↑ 4)	↑ 20 (↑ 12 to ↑ 29)
Entecavir ²	1 mg once daily × 10 days	28	NA	↑ 13 (↑ 11 to ↑ 15)	NA
Indinavir ²	800 three times daily × 7 days	12	↓ 6 (↓ 23 to ↑ 10)	↓ 2 (↓ 12 to ↑ 8)	↑ 43 (↓ 45 to ↑ 130)
Lamivudine ²	150 twice daily × 7 days	15	↓ 29 (↓ 39 to ↓ 19)	↓ 10 (↓ 17 to ↓ 3)	↑ 17 (↑ 3 to ↑ 32)
Lopinavir ²	Lopinavir/Ritonavir 400/100 twice daily × 14 days	24	↓ 14 (↓ 23 to ↓ 4)	↓ 12 (↓ 20 to ↓ 5)	↓ 11 (↓ 22 to ↑ 1)
Ritonavir			↓ 24 (↓ 46 to ↓ 3)	↓ 22 (↓ 34 to ↓ 9)	↓ 15 (↓ 32 to ↑ 2)
Ledipasvir	Ledipasvir/Sofosbuvir 90/400 once daily ^{13,14}	24	↑ 68 (↑ 54 to ↑ 84)	↑ 96 (↑ 74 to ↑ 121)	↑ 118 (↑ 91 to ↑ 150)
Sofosbuvir			↑ 1 (↓ 12 to ↑ 15)	↑ 11 (↑ 2 to ↑ 21)	NC
GS-331007 ¹²			↑ 17 (↑ 12 to ↑ 23)	↑ 31 (↑ 25 to ↑ 36)	↑ 42 (↑ 34 to ↑ 49)

Coadministered Drug	Dose of Coadministered Drug (mg)	N	% Change of Coadministered Drug Pharmacokinetic Parameters ¹ (90% CI)		
			C _{max}	AUC	C _{min}
Ledipasvir	Ledipasvir/Sofosbuvir 90/400 once daily ^{13,15}	23	↑11 (↓ 1 to ↑ 24)	↑ 12 (0 to ↑ 25)	↑ 17 (↑ 4 to ↑ 31)
Sofosbuvir			↓ 37 (↓ 48 to ↓ 25)	↓ 27 (↓ 35 to ↓ 18)	NC
GS-331007 ¹²			↑ 10 (↑ 4 to ↑ 16)	↑ 20 (↑ 16 to ↑ 24)	↑ 26 (↑ 20 to ↑ 32)
Ledipasvir	Ledipasvir/Sofosbuvir 90/400 once daily ¹⁶	15	↓ 34 (↓ 41 to ↓ 25)	↓ 34 (↓ 41 to ↓ 25)	↓ 34 (↓ 43 to ↓ 24)
Sofosbuvir			↑ 3 (↓ 13 to ↑ 23)	↓ 6 (↓ 19 to ↑ 10)	NC
GS-331007 ¹²			↓ 14 (↓ 24 to ↓ 4)	↓ 10 (↓ 17 to ↓ 3)	↑ 7 (↑ 2 to ↑ 13)
Ledipasvir	Ledipasvir/Sofosbuvir 90/400 once daily ¹⁷	14	↑ 1 (↓ 5 to ↑ 7)	↑ 8 (↑ 2 to ↑ 15)	↑ 16 (↑ 8 to ↑ 25)
Sofosbuvir			↑ 5 (↓ 7 to ↑ 20)	↑ 10 (↑ 1 to ↑ 21)	NC
GS-331007 ¹²			↑ 6 (↑ 1 to ↑ 11)	↑ 15 (↑ 11 to ↑ 19)	↑ 18 (↑ 13 to ↑ 23)
Sofosbuvir	Sofosbuvir/Velpatasvir 400/100 once daily ¹⁸	24	↑ 12 (↓ 3 to ↑ 29)	↑ 22 (↑ 12 to ↑ 33)	NC
GS-331007 ¹²			↑ 21 (↑ 12 to ↑ 29)	↑ 32 (↑ 27 to ↑ 36)	↑ 42 (↑ 37 to ↑ 49)
Velpatasvir			↑ 55 (↑ 41 to ↑ 71)	↑ 142 (↑ 123 to ↑ 164)	↑ 301 (↑ 257 to ↑ 350)
Sofosbuvir	Sofosbuvir/Velpatasvir 400/100 once daily ¹⁹	29	↓ 38 (↓ 46 to ↓ 29)	↓ 28 (↓ 34 to ↓ 20)	NC
GS-331007 ¹²			↑ 4 (↓ 1 to ↑ 8)	↑ 13 (↑ 8 to ↑ 18)	↑ 13 (↑ 6 to ↑ 19)
Velpatasvir			↓ 24 (↓ 35 to ↓ 11)	↓ 16 (↓ 28 to ↓ 2)	↑ 1 (↓ 13 to ↑ 18)
Sofosbuvir	Sofosbuvir/Velpatasvir 400/100 once daily ²⁰	14	↑ 38 (↑ 14 to ↑ 67)	↓ 3 (↓ 17 to ↑ 14)	NC
GS-331007 ¹²			↓ 14 (↓ 20 to ↓ 7)	↓ 10 (↓ 15 to ↓ 4)	↑ 1 (↓ 5 to ↑ 7)
Velpatasvir			↓ 47 (↓ 57 to ↓ 36)	↓ 53 (↓ 61 to ↓ 43)	↓ 57 (↓ 64 to ↓ 48)

Coadministered Drug	Dose of Coadministered Drug (mg)	N	% Change of Coadministered Drug Pharmacokinetic Parameters ¹ (90% CI)		
			C _{max}	AUC	C _{min}
Sofosbuvir	Sofosbuvir/Velpatasvir 400/100 once daily ²¹	24	↑ 9 (↓ 5 to ↑ 25)	↑ 16 (↑ 9 to ↑ 24)	NC
GS-331007 ¹²			↓ 4 (↓ 10 to ↑ 1)	↑ 4 (0 to ↑ 7)	↑ 12 (↑ 7 to ↑ 17)
Velpatasvir			↓ 4 (↓ 15 to ↑ 10)	↓ 1 (↓ 12 to ↑ 11)	↑ 2 (↓ 9 to ↑ 15)
Sofosbuvir	Sofosbuvir/Velpatasvir 400/100 once daily ²²	24	↑ 1 (↓ 15 to ↑ 19)	↑ 24 (↑ 13 to ↑ 37)	NC
GS-331007 ¹²			↑ 13 (↑ 7 to ↑ 18)	↑ 35 (↑ 30 to ↑ 40)	↑ 45 (↑ 38 to ↑ 52)
Velpatasvir			↑ 5 (↓ 7 to ↑ 19)	↑ 19 (↑ 7 to ↑ 34)	↑ 37 (↑ 22 to ↑ 54)
Sofosbuvir	Sofosbuvir/Velpatasvir 400/100 once daily ²³	30	↑ 9 (↓ 3 to ↑ 23)	↑ 16 (↑ 7 to ↑ 25)	NC
GS-331007 ¹²			↓ 5 (↓ 9 to ↓ 2)	↑ 3 (0 to ↑ 6)	↑ 8 (↑ 4 to ↑ 13)
Velpatasvir			↓ 3 (↓ 13 to ↑ 8)	↓ 2 (↓ 12 to ↑ 10)	↓ 3 (↓ 13 to ↑ 7)
Sofosbuvir	400/100/100 + 100 voxilaprevir ²⁴ once daily	29	↓ 30 ²⁵ (↓ 38 to ↓ 22)	↓ 22 ²⁵ (↓ 27 to ↓ 17)	NA
GS-331007 ¹²			↑ 6 ²⁵ (↑ 1 to ↑ 10)	↑ 15 ²⁵ (↑ 12 to ↑ 19)	NA
Velpatasvir			↓ 22 ²⁵ (↓ 27 to ↓ 16)	↓ 5 ²⁴ (↓ 12 to ↑ 2)	↑ 16 ²⁵ (↑ 7 to ↑ 26)
Voxilaprevir			↑ 72 ²⁵ (↑ 51 to ↑ 97)	↑ 143 ²⁵ (↑ 115 to ↑ 175)	↑ 300 ²⁵ (↑ 244 to ↑ 365)
Methadone ⁸	40-110 once daily × 14 days ⁹	13	↑ 5 (↓ 3 to ↑ 14)	↑ 5 (↓ 2 to ↑ 13)	↑ 6 (↓ 3 to ↑ 15)
Nelfinavir ²	1250 twice daily × 14 days	29	↓ 8 (↓ 15 to ↓ 1)	↓ 7 (↓ 15 to ↑ 2)	↑ 1 (↓ 15 to ↑ 19)
M8 metabolite			↓ 8 (↓ 16 to 0)	↓ 7 (↓ 17 to ↑ 5)	↓ 2 (↓ 16 to ↑ 15)
Norgestimate	Ethinyl Estradiol/ Norgestimate (Ortho- Tricyclen [®]) Once daily × 7 days	20	↓ 6 (↓ 13 to ↑ 1)	↓ 5 (↓ 9 to ↓ 1)	↓ 4 (↓ 8 to ↑ 1)
Ethinyl estradiol ¹⁰			↓ 6 (↓ 12 to 0)	↓ 4 (↓ 9 to ↑ 1)	↓ 2 (↓ 9 to ↑ 6)
Ribavirin	600 single dose	22	↓ 5 (↓ 11 to ↑ 1)	↑ 12 (↑ 6 to ↑ 17)	NC

Coadministered Drug	Dose of Coadministered Drug (mg)	N	% Change of Coadministered Drug Pharmacokinetic Parameters ¹ (90% CI)		
			C _{max}	AUC	C _{min}
Saquinavir	1000/100 twice daily ×14 days	32	↑ 22 (↑ 6 to ↑ 41)	↑ 29 ¹¹ (↑12 to ↑48)	↑ 47 ¹¹ (↑ 23 to ↑ 76)
Ritonavir			↑ 10 (↓ 5 to ↑ 28)	↑ 11 (0 to ↑ 22)	↑ 23 (↑ 3 to ↑ 46)
Sofosbuvir	Sofosbuvir 400 single dose ²⁶	16	↓ 19 (↓ 40 to ↑10)	↓ 6 (↓ 24 to ↑16)	NC
GS-331007 ¹²			↓ 23 (↓ 30 to ↓ 16)	↓ 16 (↓ 24 to ↓ 8)	NC
Tacrolimus	0.05 mg/kg twice daily × 7 days	21	↑ 3 (↓ 3 to ↑ 9)	↑ 4 (↓ 3 to ↑ 11)	↑ 10 (↑ 2 to ↑ 17)
Tipranavir ²⁷	Tipranavir/Ritonavir 500/100 twice daily	22	↓ 17 (↓ 26 to ↓ 6)	↓ 18 (↓ 25 to ↓ 9)	↓ 21 (↓ 30 to ↓ 10)
	Tipranavir/Ritonavir 750/200 twice daily (23 doses)	20	↓ 11 (↓ 16 to ↓ 4)	↓ 9 (↓ 15 to ↓ 3)	↓ 12 (↓ 22 to 0)

- Increase = ↑; Decrease = ↓; NC = Not Calculated; NA = Not Available
- Study conducted with VIREAD (tenofovir DF).
- Reyataz Prescribing Information (Bristol-Myers Squibb)
- Prezista Prescribing Information.
- 373 kcal, 8.2 g fat
- Compared with didanosine (enteric-coated) 400 mg administered alone under fasting conditions.
- In HIV-infected patients, addition of tenofovir DF to atazanavir 300 mg plus ritonavir 100 mg, resulted in AUC and C_{min} values of atazanavir that were 2.3 and 4-fold higher than the respective values observed for atazanavir 400 mg when given alone.
- R-(active), S-and total methadone exposures were equivalent when dosed alone or with VIREAD.
- Individual subjects were maintained on their stable methadone dose. No pharmacodynamic alterations (opiate toxicity or withdrawal signs or symptoms) were reported.
- Ethinyl estradiol and 17-deacetyl norgestimate (pharmacologically active metabolite) exposures were equivalent when dosed alone or with VIREAD.
- Increases in AUC and C_{min} are not expected to be clinically relevant; hence no dose adjustments are required when tenofovir DF and ritonavir-boosted saquinavir are coadministered.
- The predominant circulating nucleoside metabolite of sofosbuvir.
- Data generated from simultaneous dosing with HARVONI (ledipasvir/sofosbuvir). Staggered administration (12 hours apart) provided similar results.
- Comparison based on exposures when administered as atazanavir/ritonavir + TRUVADA coadministered with HARVONI.
- Comparison based on exposures when administered as darunavir/ritonavir + TRUVADA coadministered with HARVONI.
- Study conducted with ATRIPLA (efavirenz/emtricitabine/tenofovir DF) coadministered with HARVONI.
- Study conducted with COMPLERA (emtricitabine/rilpivirine/tenofovir) coadministered with HARVONI.
- Comparison based on exposures when administered as atazanavir/ritonavir + TRUVADA coadministered with EPCLUSA (sofosbuvir/velpatasvir).
- Comparison based on exposures when administered as darunavir/ritonavir + TRUVADA coadministered with EPCLUSA.
- Study conducted with ATRIPLA (efavirenz/emtricitabine/tenofovir DF) coadministered with EPCLUSA.

21. Study conducted with COMPLERA (emtricitabine/rilpivirine/tenofovir DF) coadministered with EPCLUSA.
22. Study conducted with STRIBILD (elvitegravir/cobicistat/emtricitabine/tenofovir DF) coadministered with EPCLUSA.
23. Comparison based on exposures when administered as raltegravir + TRUVADA coadministered with EPCLUSA.
24. Study conducted with additional voxilaprevir 100 mg to achieve voxilaprevir exposures expected in HCV-infected patients.
25. Comparison based on exposures when administered as darunavir + ritonavir + TRUVADA coadministered with VOSEVI.
26. Study conducted with ATRIPLA coadministered with SOVALDI.
27. Aptivus Prescribing Information

Drug-Food Interactions

TRUVADA can be taken with or without food. Compared to fasted administration, dosing of TRUVADA following either a high fat meal or a light meal increased the mean AUC and C_{max} of tenofovir by 35% and 15%, respectively, without affecting emtricitabine exposures (see **ACTIONS AND CLINICAL PHARMACOLOGY, Effect of Food on Absorption**).

Drug-Herb Interactions

Interactions of TRUVADA with herbs have not been established.

Drug-Laboratory Interactions

Interactions of TRUVADA with laboratory tests have not been established.

DOSAGE AND ADMINISTRATION

Recommended Dose

Treatment of HIV-1 Infection

The dose of TRUVADA is one tablet (containing 200 mg of emtricitabine and 300 mg of tenofovir DF) once daily taken orally with or without food.

Pre-exposure Prophylaxis of HIV-1 Infection

The dose of TRUVADA is one tablet (containing 200 mg of emtricitabine and 300 mg of tenofovir DF) once daily taken orally with or without food.

Special Populations

Dose Adjustment for Renal Impairment

Treatment of HIV-1 Infection

Significantly increased drug exposures occurred when EMTRIVA or VIREAD were administered to patients with moderate to severe renal impairment (see **ACTION AND**

CLINICAL PHARMACOLOGY, Special Populations and Conditions, Renal Insufficiency). Therefore, the dosing interval of TRUVADA should be adjusted in HIV-1 infected adult patients with baseline creatinine clearance 30–49 mL/min using the recommendations in Table 13. These dosing interval recommendations are based on modeling of single-dose pharmacokinetic data in non-HIV infected subjects with varying degrees of renal impairment, including end-stage renal disease requiring hemodialysis. The safety and effectiveness of these dosing interval adjustment recommendations have not been clinically evaluated in moderate to severe renal impairment, therefore, clinical response to treatment and renal function should be closely monitored in these patients.

No dose adjustment of TRUVADA tablets is necessary with mild renal impairment patients (creatinine clearance 50-80 mL/min). Routine monitoring of calculated creatinine clearance, serum phosphorus, urine glucose, and urine protein should be performed for patients with mild renal impairment (creatinine clearance 50–80 mL/min) (see **WARNINGS AND PRECAUTIONS**).

Table 13 Dosage Adjustment for HIV-1 Infected Adult Patients with Altered Creatinine Clearance

	Creatinine Clearance (mL/min) ¹		
	≥50	30–49	<30 (Including Patients Requiring Hemodialysis)
Recommended Dosing Interval	Every 24 hours	Every 48 hours	TRUVADA should not be administered.

1. Calculated using ideal (lean) body weight.

Pre-exposure Prophylaxis of HIV-1 Infection

Do not use TRUVADA for PrEP in HIV-1 uninfected individuals with creatinine clearance below 60 mL/min (see **WARNINGS AND PRECAUTIONS**).

No dose adjustment of TRUVADA tablets is necessary with mild renal impairment patients (creatinine clearance 50-80 mL/min). Routine monitoring of calculated creatinine clearance, serum phosphorus, urine glucose and urine protein should be performed in all individuals with mild renal impairment. If a decrease in calculated creatinine clearance is observed in uninfected individuals while using TRUVADA for PrEP, evaluate potential causes and re-assess potential risks and benefits of continued use (see **WARNINGS AND PRECAUTIONS**).

Hepatic Impairment

No dose adjustment is required in patients with hepatic impairment (see **WARNINGS AND PRECAUTIONS**).

Geriatrics (>65 years of age)

Clinical studies of EMTRIVA or VIREAD did not include sufficient numbers of subjects aged 65 and over to determine whether they respond differently than younger subjects. In general, dose selection for the elderly patient should be cautious, keeping in mind the greater frequency of decreased hepatic, renal, or cardiac function, and of concomitant disease or other drug therapy.

Missed Dose

If a patient misses a dose within 12 hours of the regularly scheduled time, but then remembers it that same day, the patient should take the missed dose with food as soon as possible and resume their normal dosing schedule. If a patient misses a dose of TRUVADA by more than 12 hours and it is almost time for their next dose, the patient should not take the missed dose and simply resume the usual dosing schedule. The patient should not take more than 1 dose of TRUVADA in a day, and should not take 2 doses of TRUVADA at the same time to make up for missing a dose.

Uninfected individuals who miss doses are at greater risk of acquiring HIV-1 than those who do not miss doses (see WARNINGS AND PRECAUTIONS).

OVERDOSAGE

For management of a suspected drug overdose, please contact your regional Poison Control Centre.

If overdose occurs the patient must be monitored for evidence of toxicity, and standard supportive treatment applied as necessary.

Emtricitabine: Limited clinical experience is available at doses higher than the therapeutic dose of EMTRIVA. In one clinical pharmacology study single doses of emtricitabine 1200 mg were administered to 11 patients. No severe adverse reactions were reported. The effects of higher doses are not known.

Hemodialysis treatment removes approximately 30% of the emtricitabine dose over a 3-hour dialysis period starting within 1.5 hours of emtricitabine dosing (blood flow rate of 400 mL/min and a dialysate flow rate of 600 mL/min); however, a single treatment does not significantly affect emtricitabine C_{max} or AUC. It is not known whether emtricitabine can be removed by peritoneal dialysis.

Tenofovir DF: Limited clinical experience at doses higher than the therapeutic dose of VIREAD 300 mg is available. In one study, 600 mg tenofovir DF was administered to 8 patients orally for 28 days. No severe adverse reactions were reported. The effects of higher doses are not known.

Tenofovir is efficiently removed by hemodialysis with an extraction coefficient of approximately 54%. Following a single 300 mg dose of VIREAD, a four-hour hemodialysis session removed approximately 10% of the administered tenofovir dose.

ACTION AND CLINICAL PHARMACOLOGY

Mechanism of Action

TRUVADA is a fixed-dose combination of antiviral drugs, emtricitabine and tenofovir DF (see **VIROLOGY**).

Pharmacokinetics

TRUVADA: One TRUVADA Tablet was bioequivalent to one EMTRIVA Capsule (200 mg) plus one VIREAD Tablet (300 mg) following single-dose administration to fasting healthy subjects (N=39).

Emtricitabine: The pharmacokinetic properties of emtricitabine are summarized in Table 14. Following oral administration of EMTRIVA, emtricitabine is rapidly absorbed with peak plasma concentrations occurring at 1–2 hours post-dose. In vitro binding of emtricitabine to human plasma proteins is <4% and is independent of concentration over the range of 0.02–200 µg/mL. Following administration of radiolabelled emtricitabine, approximately 86% is recovered in the urine and 13% is recovered as metabolites. The metabolites of emtricitabine include 3'-sulfoxide diastereomers and their glucuronic acid conjugate. Emtricitabine is eliminated by a combination of glomerular filtration and active tubular secretion. Following a single oral dose of EMTRIVA, the plasma emtricitabine half-life is approximately 10 hours.

Tenofovir DF: The pharmacokinetic properties of tenofovir DF are summarized in Table 14. Following oral administration of VIREAD, maximum tenofovir serum concentrations are achieved in 1.0 ± 0.4 hour. In vitro binding of tenofovir to human plasma proteins is <0.7% and is independent of concentration over the range of 0.01–25 µg/mL. Approximately 70–80% of the intravenous dose of tenofovir is recovered as unchanged drug in the urine. Tenofovir is eliminated by a combination of glomerular filtration and active tubular secretion. Following a single oral dose of VIREAD, the terminal elimination half-life of tenofovir is approximately 17 hours.

Table 14 **Single Dose Pharmacokinetic Parameters for Emtricitabine and Tenofovir in Adults**

	Emtricitabine	Tenofovir
Fasted Oral Bioavailability ² (%)	92 (83.1–106.4)	25 (NC–45.0) ¹
Plasma Terminal Elimination Half-Life ² (hr)	10 (7.4–18.0)	17 (12.0–25.7)
C _{max} ³ (µg/mL)	1.8 ± 0.72 ⁴	0.30 ± 0.09
AUC ³ (µg·hr/mL)	10.0 ± 3.12 ⁴	2.29 ± 0.69
CL/F ³ (mL/min)	302 ± 94	1043 ± 115
CL _{renal} ³ (mL/min)	213 ± 89	243 ± 33

1. NC = Not calculated
2. Median (range)
3. Mean ± SD
4. Data presented as steady state values.

Effects of Food on Oral Absorption

TRUVADA may be administered with or without food. Administration of TRUVADA following a high fat meal (784 kcal; 49 grams of fat) or a light meal (373 kcal; 8 grams of fat) delayed the time of tenofovir C_{max} by approximately 0.75 hour. The mean increases in tenofovir AUC and C_{max} were approximately 35% and 15%, respectively, when administered with a high fat or light meal, compared to administration in the fasted state. In previous safety and efficacy studies, VIREAD (tenofovir) was taken under fed conditions. Emtricitabine systemic exposures (AUC and C_{max}) were unaffected when TRUVADA was administered with either a high fat or a light meal.

Special Populations and Conditions

Pediatrics and Geriatrics

Pharmacokinetics of emtricitabine and tenofovir have not been fully evaluated in children (<18 years) or in the elderly (>65 years).

Race

Emtricitabine: No pharmacokinetic differences due to race have been identified following the administration of EMTRIVA.

Tenofovir DF: There were insufficient numbers from racial and ethnic groups other than Caucasian to adequately determine potential pharmacokinetic differences among these populations.

Gender

Emtricitabine and tenofovir DF: Emtricitabine and tenofovir pharmacokinetics are similar in male and female patients.

Hepatic Insufficiency

The pharmacokinetics of tenofovir following a 300 mg single dose of VIREAD have been studied in non-HIV infected subjects with moderate to severe hepatic impairment. There were no substantial alterations in tenofovir pharmacokinetics in subjects with hepatic impairment compared with unimpaired subjects. The pharmacokinetics of TRUVADA or emtricitabine have not been studied in patients with hepatic impairment; however, emtricitabine has not been shown to be significantly metabolized by liver enzymes, so the impact of liver impairment is likely to be limited.

Renal Insufficiency

The pharmacokinetics of emtricitabine and tenofovir are altered in patients with renal insufficiency. In patients with creatinine clearance <50 mL/min, C_{max} and $AUC_{0-\infty}$ of emtricitabine and tenofovir were increased (see **WARNINGS, Nephrotoxicity**).

It is recommended that the dosing interval for TRUVADA be modified in HIV-1 infected patients with creatinine clearance 30–49 mL/min. TRUVADA should not be used in HIV-1 infected patients with creatinine clearance <30 mL/min and in patients with end-stage renal disease requiring dialysis (see **DOSAGE AND ADMINISTRATION**).

TRUVADA for PrEP has not been studied and should not be used in HIV-1 uninfected individuals with creatinine clearance below 60 mL/min. (see **DOSAGE AND ADMINISTRATION**).

STORAGE AND STABILITY

Store at 15–30 °C (59–86 °F).

- Keep container tightly closed
- Dispense only in original container
- Do not use if seal over bottle opening is broken or missing.

SPECIAL HANDLING INSTRUCTIONS

There are no special handling instructions.

DOSAGE FORMS, COMPOSITION AND PACKAGING

TRUVADA is available as tablets. Each tablet contains 200 mg of emtricitabine and 300 mg of tenofovir DF (which is equivalent to 245 mg of tenofovir disoproxil), as active ingredients. The tablets also include the following inactive ingredients: croscarmellose

sodium, lactose monohydrate, magnesium stearate, microcrystalline cellulose, and pregelatinized starch (gluten free). The tablets are coated with Opadry II Blue Y-30-10701, which contains FD&C Blue #2 aluminum lake, hydropropylmethylcellulose 2910, lactose monohydrate, titanium dioxide, and triacetin. The tablets are blue, capsule-shaped, film-coated, debossed with “GILEAD” on one side and with “701” on the other side. Each bottle contains 30 tablets and a desiccant (silica gel canister or sachet) and is closed with a child-resistant closure.

PART II. SCIENTIFIC INFORMATION

PHARMACEUTICAL INFORMATION

Drug Substance

Emtricitabine:

Common Name: emtricitabine (USAN)

Chemical Name: 5-fluoro-1-(2R,5S)-[2-(hydroxymethyl)-1,3-oxathiolan-5-yl]cytosine

Empirical Formula: C₈H₁₀FN₃O₃S

Molecular Weight: 247.24

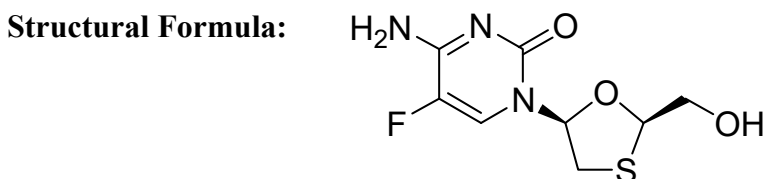

Physicochemical

Properties:

Physical Description: Emtricitabine is a white to off-white crystalline powder.

Solubility: The solubility of emtricitabine is approximately 112 mg/mL in water at 25 °C. The partition coefficient (log p) for emtricitabine is -0.43 and the pKa is 2.65.

Tenofovir DF:

Common Name: tenofovir disoproxil fumarate (USAN)

Chemical Name: 9-[(R)-2-[[bis[[[(isopropoxycarbonyl)oxy]methoxy]phosphinyl]-methoxy]propyl]adenine fumarate (1:1)

Empirical Formula: C₁₉H₃₀N₅O₁₀P • C₄H₄O₄

Molecular Weight: 635.52

Structural Formula:

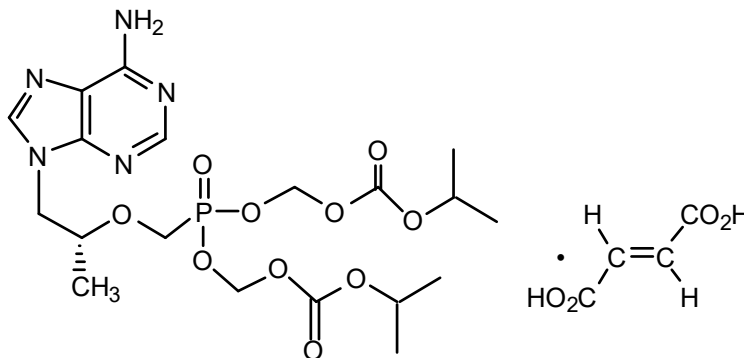

Physicochemical Properties:

Physical Description: Tenofovir disoproxil fumarate is a white to off-white crystalline powder.

Solubility: The solubility of tenofovir disoproxil fumarate is 13.4 mg/mL in water at 25 °C. The partition coefficient (log p) for tenofovir disoproxil is 1.25 and the pKa is 3.75.

CLINICAL TRIALS

Clinical Studies in Patients with HIV-1 Infection

Study Demographics and Trial Design

Description of Clinical Studies

For safety and efficacy studies using EMTRIVA or VIREAD in combination with other antiretroviral agents, also consult the Product Monograph for these products.

Clinical Study 934 supports the use of TRUVADA tablets for the treatment of HIV-1 infection. Additional data in support of the use of TRUVADA are derived from Study 903, in which lamivudine and tenofovir DF were used in combination in treatment-naïve adults, and clinical Study 303 in which EMTRIVA and lamivudine demonstrated comparable

efficacy, safety and resistance patterns as part of multidrug regimens (see Table 19 and Table 20).

Table 15 Study 934 EMTRIVA + VIREAD + Efavirenz Compared with Lamivudine/Zidovudine + Efavirenz

Study Number	Trial Design	Dosage, Route of Administration and Duration	Study Subjects (N=511)	Mean Age	Gender
GS-01-934	Randomized, open-label, parallel, multicenter, active controlled study. Arm 1: emtricitabine+ tenofovir DF+ efavirenz Arm 2: lamivudine/ zidovudine + efavirenz	Arm 1 ¹ : efavirenz 600 mg once daily for oral administration, emtricitabine 200 mg once and tenofovir DF 300 mg once daily Arm 2: efavirenz 600 mg once daily for oral administration and Combivir (lamivudine/zidovudine) 150/300 mg twice daily. 144 weeks	Antiretroviral naïve patients (HIV-1 RNA > 10,000 copies/mL) (N=511)	Mean 38 years (18–80)	Male : 86% Female: 14%

¹From weeks 96 to 144 of the study, patients received TRUVADA with efavirenz in place of emtricitabine + VIREAD

Data through 144 weeks are reported for Study 934, a randomized, open-label, active controlled multicenter study comparing EMTRIVA + VIREAD administered in combination with efavirenz versus lamivudine/zidovudine administered in combination with efavirenz in 511 antiretroviral-naïve patients. From weeks 96 to 144 of the study, patients randomized to EMTRIVA + VIREAD received TRUVADA with efavirenz in place of EMTRIVA + VIREAD. Patients had a mean age of 38 years (range 18–80), 86% were male, 59% were Caucasian and 23% were Black. The mean baseline CD4 cell count was 245 cells/mm³ (range 2–1191) and median baseline plasma HIV-1RNA was 5.01 log₁₀ copies/mL (range 3.56–6.54). Patients were stratified by baseline CD4 count (< or ≥200 cells/mm³); 41% had CD4 cell counts <200 cells/mm³ and 51% of patients had baseline viral loads >100,000 copies/mL.

EMTRIVA:

Table 16 Study 303: EMTRIVA QD + Stable Background Therapy (SBT) Compared to Lamivudine BID + SBT

Study No.	Trial Design	Dosage, Route of Administration and Duration	Study Subjects (N=440)	Mean Age (Range)	Gender
FTC-303	Randomized (2:1), open-label, active-controlled switch study. Arm 1: emtricitabine + (d4T or ZDV + PI or NNRTI) Arm 2: lamivudine + (d4T or ZDV + PI or NNRTI)	Arm 1: emtricitabine 200 mg capsules orally, QD + (d4T or ZDV + PI or NNRTI) for 48 weeks Arm 2: lamivudine 150 mg tablet orally, BID + (d4T or ZDV + PI or NNRTI) for 48 weeks	Stable treatment-experienced (HIV-1 RNA <400 copies/mL) (N=440)	42 years (22–80)	Male: 86% Female: 14%

Study 303 was a 48-week, open-label, active-controlled multicenter study comparing EMTRIVA (200 mg QD) to lamivudine, in combination with stavudine or zidovudine and a protease inhibitor or NNRTI in 440 patients who were on a lamivudine-containing triple-antiretroviral drug regimen for at least 12 weeks prior to study entry and had HIV-1 RNA ≤400 copies/mL.

Patients were randomized 1:2 to continue therapy with lamivudine (150 mg BID) or to switch to EMTRIVA (200 mg QD). All patients were maintained on their stable background regimen. Patients had a mean age of 42 years (range 22–80), 86% were male, 64% Caucasian, 21% African-American and 13% Hispanic. Patients had a mean baseline CD4 cell count of 527 cells/mm³ (range 37–1909), and a median baseline plasma HIV RNA of 1.7 log₁₀ copies/mL (range 1.7–4.0). The median duration of prior antiretroviral therapy was 27.6 months.

VIREAD:

Table 17 Study 903: VIREAD + Lamivudine + Efavirenz Compared with Stavudine + Lamivudine + Efavirenz

Study No.	Trial Design	Dosage, Route of Administration and Duration	Study Subjects (N=600)	Mean Age (Range)	Gender
GS-99-903	Randomized (1:1), double-blind, active-controlled, equivalence study. Arm 1: tenofovir DF + lamivudine + efavirenz Arm 2: stavudine + lamivudine + efavirenz	Arm 1: tenofovir DF 300 mg tablets QD, stavudine placebo capsules BID, lamivudine 150 mg tablets BID, efavirenz 600 mg QD Arm 2: tenofovir DF placebo tablets QD, stavudine ¹ capsules 40/30 mg BID, lamivudine 150 mg tablets BID, efavirenz 600 mg QD All for oral (PO) administration for 144 weeks double-blind phase followed by 192-week open-label phase. (Nevirapine 200 mg BID could replace efavirenz in the event of efavirenz-associated central nervous system toxicity or rash.)	Treatment-naïve (HIV-1 RNA >5,000 copies/mL) (N=600)	36 years (18–64)	Male: 74% Female: 26%

1. Stavudine/placebo capsules 20/15 mg BID as need for dose reduction.

Study 903 is a double-blind, active-controlled multicenter study comparing VIREAD (300 mg QD) administered in combination with lamivudine and efavirenz versus stavudine, lamivudine, and efavirenz in 600 antiretroviral-naïve patients. Patients had a mean age of 36 years (range 18–64), 74% were male, 64% were Caucasian and 20% were Black. The mean baseline CD4 cell count was 279 cells/mm³ (range 3–956) and median baseline plasma HIV-1 RNA was 77,600 copies/mL (range 417–5,130,000). Patients were stratified by baseline HIV-1 RNA and CD4 count. Forty-three percent of patients had baseline viral loads >100,000 copies/mL and 39% had CD4 cell counts <200 cells/mm³.

Study Results

EMTRIVA and VIREAD

Study 934: EMTRIVA + VIREAD + Efavirenz Compared with Lamivudine/Zidovudine + Efavirenz

Treatment outcomes through 48 and 144 weeks for those patients who did not have efavirenz resistance at baseline are presented in Table 18.

Table 18 Outcomes of Randomized Treatment at Weeks 48 and 144 (Study 934)

Outcome	At Week 48		At Week 144 ¹	
	EMTRIVA+ VIREAD +EFV	3TC+AZT +EFV	EMTRIVA+ VIREAD+ EFV	3TC/AZT +EFV
	(N=244)	(N=243)	(N=227)	(N=229)
Responder ²	84%	73%	71%	58%
Virologic failure ³	2%	4%	3%	6%
Rebound	1%	3%	2%	5%
Never suppressed	0%	0%	0%	0%
Change in antiretroviral regimen	1%	1%	1%	1%
Death	<1%	1%	1%	1%
Discontinued due to adverse event	4%	9%	5%	12%
Discontinued for other reasons ⁴	10%	14%	20%	22%

1. Patients who were responders at Week 48 or Week 96 but did not consent to continue study after Week 48 or Week 96 were excluded from analysis.
2. Patients achieved and maintained confirmed HIV-1 RNA <400 copies/mL through Week 48.
3. Includes confirmed viral rebound and failure to achieve confirmed <400 copies/mL through Week 48.
4. Includes lost to follow-up, patient withdrawal, non-compliance, protocol violation and other reasons.

In this study, EMTRIVA + VIREAD in combination with efavirenz demonstrated statistically significant superiority to lamivudine/zidovudine in combination with efavirenz in achieving and maintaining HIV-1 RNA <400 copies/mL through 48 weeks and 144 weeks (Table 18). The difference in the percentages of responders, stratified by baseline CD4 cell count (< or ≥200 cells/mm³), between the EMTRIVA + VIREAD group and the lamivudine/zidovudine group was 11.4%, and the 95% CI was 4.3% to 18.6% (p=0.002) at Week 48 and was 13% at Week 144, 95% CI = 4% to 22% (p=0.004). Through 48 weeks of therapy, 80% and 70% of patients in the EMTRIVA + VIREAD and the lamivudine/zidovudine arms, respectively, achieved and maintained HIV-1 RNA <50 copies/mL (64% and 56%, respectively, through Week 144). The difference in the percentages of responders stratified by baseline CD4 cell count (< or ≥200 cells/mm³) between the EMTRIVA + VIREAD group and the lamivudine/zidovudine group was 9.1%,

and the 95% CI was 1.6% to 16.6% (p=0.021) at Week 48 and was 8% at Week 144, 95% CI = -1% to 17% (p=0.082). The mean increase from baseline in CD4 cell count was 190 cells/mm³ for the EMTRIVA + VIREAD + efavirenz arm, and 158 cells/mm³ for the lamivudine/zidovudine + efavirenz arm (p=0.002) at Week 48 (312 and 271 cells/mm³, respectively, at Week 144, p=0.089).

The difference in the proportion of patients who achieved and maintained HIV-1 RNA <400 copies/mL through 48 weeks largely results from the higher number of discontinuations due to adverse events and other reasons in the zidovudine/lamivudine group in this open label study.

EMTRIVA:

Study 303: EMTRIVA QD + Stable Background Therapy (SBT) Compared to Lamivudine BID + SBT

Treatment outcomes through 48 weeks are presented in Table 19.

Table 19 Outcomes of Randomized Treatment at Week 48 (Study 303)

Outcome at Week 48	EMTRIVA + ZDV/d4T + NNRTI/PI (N=294)	Lamivudine + ZDV/d4T + NNRTI/PI (N=146)
Responder ¹	77% (67%)	82% (72%)
Virologic Failure ²	7%	8%
Death	0%	<1%
Study Discontinuation Due to Adverse Event	4%	0%
Study Discontinuation For Other Reasons ³	12%	10%

1. Patients achieved and maintained confirmed HIV RNA <400 copies/mL (<50 copies/mL) through Week 48.
2. Includes patients who failed to achieve virologic suppression or rebounded after achieving virologic suppression.
3. Includes lost to follow-up, patient withdrawal, non-compliance, protocol violation and other reasons.

The mean increase from baseline in CD4 cell count was 29 cells/mm³ for the EMTRIVA arm and 61 cells/mm³ for the lamivudine arm. Through 48 weeks, in the EMTRIVA group 2 patients (0.7%) experienced a new CDC Class C event, compared to 2 patients (1.4%) in the lamivudine group.

VIREAD:

Study 903: VIREAD + Lamivudine + Efavirenz Compared with Stavudine + Lamivudine + Efavirenz

Treatment outcomes at Week 48 and Week 144 are presented in Table 20 below.

Table 20 Outcomes of Randomized Treatment (Study 903)

Outcomes	At Week 48		At Week 144	
	VIREAD + 3TC + EFV (N=299)	Stavudine + 3TC + EFV (N=301)	VIREAD + 3TC + EFV (N=299)	Stavudine + 3TC + EFV (N=301)
	%	%	%	%
Responder ¹	79% (76%)	82% (79%)	68% (62%)	62% (58%)
Virologic failure ²	6%	4%	10%	8%
Rebound	5%	3%	8%	7%
Never suppressed	0%	1%	0%	0%
Added an antiretroviral agent	1%	1%	2%	1%
Death	<1%	1%	<1%	2%
Discontinued due to adverse event	6%	6%	8%	13%
Discontinued for other reasons ³	8%	7%	14%	15%

1. Patients achieved and maintained confirmed HIV-1 RNA <400 copies/mL (<50 copies/mL) at Weeks 48 and 144.
2. Includes confirmed viral rebound and failure to achieve confirmed <400 copies/mL through Week 48 and 144.
3. Includes lost to follow-up, patient's withdrawal, noncompliance, protocol violation and other reasons.

Through 48 weeks, the mean increase from baseline in CD4 cell count was 169 cells/mm³ for the VIREAD arm and 167 cells/mm³ for the stavudine arm. Eight patients in the VIREAD group and six patients in the stavudine group experienced a new CDC Class C event.

Through 144 weeks, the mean increase from baseline in CD4 cell count was 263 cells/mm³ for the VIREAD arm and 283 cells/mm³ for the stavudine arm. Eleven patients in the VIREAD group and nine patients in the stavudine group experienced a new CDC Class C event.

Clinical Studies in HIV-1 Uninfected Subjects

The iPrEx study and Partners PrEP study support the use of TRUVADA to help reduce the risk of acquiring HIV-1.

iPrEx Trial

The study demographics and trial design for the iPrEx Trial are summarized in Table 21.

Table 21 Study Demographics and Trial Design of iPrEx Trial

Study No.	Trial Design	Dosage, Route of Administration and Duration	Study Subjects (N=2499)	Mean Age (Range)	Gender
CO-US-104-0288 (iPrEx)	Randomized, double-blind, placebo-controlled multinational study in men and transgender women who have sex with men and with evidence of high risk behavior for HIV-1 infection Arm 1: TRUVADA Arm 2: placebo	Arm 1: TRUVADA tablet taken orally QD Arm 2: Placebo tablet taken orally QD Duration of treatment was variable. Subjects remained on treatment until the target number of seroconversion events was identified and the last enrolled study subject completed 48 weeks of treatment. Subjects were followed for at least 8 weeks follow up. HBsAg reactive subjects were followed for hepatic flares for 24 weeks after study drug discontinuation. Subjects who HIV-1 seroconverted during study were followed through at least 24 weeks after the last dose of study drugs	Randomized: 1251 – TRUVADA 1248 –placebo Race: Asian – 5% Black – 9% White – 18% Hispanic/Latino – 72%	27 (18 to 67 years)	Male: 100% subjects born male 29 (1%) report current identity as female

Evidence of high risk behavior included any one of the following reported to have occurred up to six months prior to study screening: no condom use during anal intercourse with an HIV-1 positive partner or a partner of unknown HIV-1 status; anal intercourse with more than 3 sex partners; exchange of money, gifts, shelter or drugs for anal sex; sex with male partner and diagnosis of sexually transmitted infection; no consistent use of condoms with sex partner known to be HIV-1 positive.

All subjects received monthly HIV-1 testing, risk-reduction counseling, condoms and management of sexually transmitted infections.

Partners PrEP Study

The demographics and trial design for the Partners PrEP study are summarized in Table 22.

Table 22 Study Demographics and Trial Design of Partners PrEP Trial

Study No.	Trial Design	Dosage, Route of Administration and Duration	Study Subjects (N=4758)	Mean Age (Range)	Gender
CO-US-104-0380 (Partners PrEP)	Randomized, double-blind, placebo-controlled 3-arm trial conducted in serodiscordant heterosexual couples in Kenya and Uganda	Arm 1: Viread tablet taken orally QD Arm 2: TRUVADA tablet taken orally QD Arm 3: Matched Placebo tablets, taken orally QD. Duration of study drug treatment was variable. Subjects received the assigned study drugs once daily for a minimum of 24 months up to a maximum of 36 months.	Randomized: 1589 –TDF 1583 – TRUVADA 1586 – placebo	33–34	Female: 38% Male 62%

All subjects received monthly HIV-1 testing, evaluation of adherence, assessment of sexual behavior, and safety evaluations. Women were also tested monthly for pregnancy. Women who became pregnant during the trial had study drug interrupted for the duration of the pregnancy and while breastfeeding. The uninfected partner subjects were predominantly male (61–64% across study drug groups).

Study Results

iPrEx Study

Subjects were followed for 4237 person-years. The primary outcome measure for the study was the incidence of documented HIV-1 seroconversion. The results of the iPrEx study are summarized below in Table 23.

Table 23 iPrEx Study: Relative Risk Reduction Through End-of-Treatment Cutoff (Primary Analysis; mITT Analysis^a)

	Placebo	TRUVADA	P-value ^b
End of Treatment^c			
mITT Analysis	N=1217	N=1224	0.002
Person-Years follow-up ^d	2113	2124	
Number of HIV-1 Infections (Seroconversions)	83	48	
Relative Risk Reduction (2-sided 95% CI)	42% (18%, 60%)		

Abbreviation: CI = confidence interval

- a Modified Intent-to-Treat (mITT) analysis excludes subjects who do not have follow-up HIV test and who were infected at enrollment
- b p-values by log rank test
- c End of treatment is defined as the next post-treatment visit after this date (approximately one month). This analysis excludes post-treatment stop seroconversions.
- d Time to first evidence of seroconversion for those with event

Risk reduction was found to be higher (53%; 95% CI: 34% to 72%) among subjects who reported previous unprotected anal intercourse (URAI) at screening (732 and 753 subjects reported URAI within the last 12 weeks at screening in the TRUVADA and placebo groups, respectively). In a post-hoc case control study of plasma and intracellular drug levels in about 10% of study subjects, risk reduction appeared to be the greatest in subjects with detectable intracellular tenofovir. Efficacy was therefore strongly correlated with adherence.

Partners PrEP Study

The efficacy analyses results of the Partner’s PrEP study are summarized in Table 24 below.

Table 24 Partners PrEP Study: Relative Risk Reduction and HIV-1 Seroincidence for Partner Subjects (Primary Analysis; mITT Analysis^a)

	TRUVADA	VIREAD	Placebo	Total
mITT Analysis	N=1576	N=1579	N=1578	N=4733
Person-years of follow-up ^b	2616	2604	2607	7827
Number of HIV-1 Infections (Seroconversions)	13	17	52	82
HIV-1 incidence, per 100 person-years	0.50	0.65	1.99	1.05
Relative Risk Reduction (2-sided 95% CI)	75% (55-87%)	67% (44-81%)		
p-value ^c	<0.0001	<0.0001		

- a Modified Intent-to-Treat (mITT) analysis excludes subjects who were infected at enrollment
- b Time to first evidence of seroconversion for those with event

c p-values using Cox's proportional hazards model for the active study drug relative to placebo

Two of the 13 seroconversions in the TRUVADA arm and 3 of the 52 seroconversions in the placebo arm occurred in women during treatment interruptions for pregnancy. In a post-hoc case control study of plasma drug levels in about 10% of study subjects, risk reduction was most pronounced in subjects with detectable plasma tenofovir. Efficacy was therefore strongly correlated with adherence.

VIROLOGY (MICROBIOLOGY)

Mechanism of Action

Emtricitabine: Emtricitabine, a synthetic nucleoside analog of cytidine, is phosphorylated by cellular enzymes to form emtricitabine 5'-triphosphate. Emtricitabine 5'-triphosphate inhibits the activity of the HIV-1 reverse transcriptase (RT) by competing with the natural substrate deoxycytidine 5'-triphosphate and by being incorporated into nascent viral DNA which results in chain termination. Emtricitabine 5'-triphosphate is a weak inhibitor of mammalian DNA polymerases α , β , ϵ and mitochondrial DNA polymerase γ .

Tenofovir DF: Tenofovir DF is an acyclic nucleoside phosphonate diester analog of adenosine monophosphate. Tenofovir DF requires initial diester hydrolysis for conversion to tenofovir and subsequent phosphorylations by cellular enzymes to form tenofovir diphosphate. Tenofovir diphosphate inhibits the activity of HIV-1 RT by competing with the natural substrate deoxyadenosine 5'-triphosphate and, after incorporation into DNA, by DNA chain termination. Tenofovir diphosphate is a weak inhibitor of mammalian DNA polymerases α , β , and mitochondrial DNA polymerase γ .

Antiviral Activity

Emtricitabine and tenofovir DF: In combination studies evaluating the in vitro antiviral activity of emtricitabine and tenofovir together, synergistic antiviral effects were observed. Additive to synergistic effects were observed in combination studies with protease inhibitors, integrase strand transfer inhibitors, and with nucleoside and non-nucleoside analogue inhibitors of HIV-1 reverse transcriptase.

Emtricitabine: The in vitro antiviral activity of emtricitabine against laboratory and clinical isolates of HIV was assessed in lymphoblastoid cell lines, the MAGI-CCR5 cell line, and peripheral blood mononuclear cells. The IC_{50} values for emtricitabine were in the range of 0.0013–0.64 μ M (0.0003–0.158 μ g/mL). In drug combination studies of emtricitabine with nucleoside reverse transcriptase inhibitors (abacavir, lamivudine, stavudine, zalcitabine, or zidovudine), non-nucleoside reverse transcriptase inhibitors (delavirdine, efavirenz, or nevirapine), protease inhibitors (amprenavir, nelfinavir, ritonavir, or saquinavir), and with integrase strand transfer inhibitors, additive to synergistic effects were observed. Most of these drug combinations have not been studied in humans. Emtricitabine displayed antiviral activity in vitro against HIV-1 clades A, B, C, D, E, F, and G (IC_{50} values ranged from 0.007–0.075 μ M) and showed strain specific activity against HIV-2 (IC_{50} values ranged from 0.007–1.5 μ M).

Tenofovir DF: The in vitro antiviral activity of tenofovir against laboratory and clinical isolates of HIV-1 was assessed in lymphoblastoid cell lines, primary monocyte/macrophage cells and peripheral blood lymphocytes. The IC₅₀ (50% inhibitory concentration) values for tenofovir were in the range of 0.04–8.5 µM. In drug combination studies of tenofovir with integrase strand transfer inhibitors, nucleoside reverse transcriptase inhibitors (abacavir, didanosine, lamivudine, stavudine, zalcitabine, or zidovudine), non-nucleoside reverse transcriptase inhibitors (delavirdine, efavirenz, or nevirapine), and protease inhibitors (amprenavir, indinavir, nelfinavir, ritonavir, or saquinavir), additive to synergistic effects were observed. Most of these drug combinations have not been studied in humans. Tenofovir displayed antiviral activity in vitro against HIV-1 clades A, B, C, D, E, F, G, and O (IC₅₀ values ranged from 0.5–2.2 µM).

Prophylactic Activity in a Nonhuman Primate Model of HIV Transmission

Emtricitabine and tenofovir DF: The prophylactic activity of the combination of daily oral emtricitabine and tenofovir DF was evaluated in a controlled study of macaques inoculated once weekly for 14 weeks with SIV/HIV-1 chimeric virus (SHIV) applied to the rectal surface. Of the 18 control animals, 17 became infected after a median of 2 weeks. In contrast, 4 of the 6 animals treated daily with oral emtricitabine and tenofovir DF remained uninfected and the two infections that did occur were significantly delayed until 9 and 12 weeks and exhibited reduced viremia. An M184I-expressing FTC-resistant variant emerged in 1 of the 2 macaques after 3 weeks of continued drug exposure.

Resistance

Emtricitabine and tenofovir DF: HIV-1 isolates with reduced susceptibility to the combination of emtricitabine and tenofovir have been selected in vitro. Genotypic analysis of these isolates identified the M184V/I and/or K65R amino acid substitutions in the viral RT. In addition, a K70E substitution in HIV-1 reverse transcriptase has been selected by tenofovir and results in reduced susceptibility to tenofovir.

In Study 934 (EMTRIVA + VIREAD + efavirenz compared with lamivudine/zidovudine + efavirenz), resistance analysis was performed on HIV isolates from all patients with >400 copies/mL of HIV-1 RNA at Week 144 or early discontinuation. Genotypic resistance to efavirenz, predominantly the K103N mutation, was the most common form of resistance that developed. Resistance to efavirenz occurred in 13/19 (68%) analyzed patients in the EMTRIVA + VIREAD group and in 21/29 (72%) analyzed patients in the lamivudine/zidovudine group. The M184V mutation, associated with resistance to EMTRIVA and lamivudine, was observed in 2/19 (11%) analyzed patients in the EMTRIVA + VIREAD group and in 10/29 (34%) analyzed patients in the lamivudine/zidovudine group.

In treatment-naïve patients treated with EMTRIVA + VIREAD + efavirenz, none of the HIV isolates from 19 patients analyzed for resistance showed reduced susceptibility to tenofovir or the presence of the K65R or K70E mutation.

Emtricitabine: Emtricitabine-resistant isolates of HIV have been selected in vitro. Genotypic analysis of these isolates showed that the reduced susceptibility to emtricitabine was associated with a mutation in the HIV RT gene at codon 184 which resulted in an amino acid substitution of methionine by valine or isoleucine (M184V/I).

Emtricitabine-resistant isolates of HIV have been recovered from some patients treated with emtricitabine alone or in combination with other antiretroviral agents. In a clinical study, viral isolates from 6/16 (37.5%) treatment-naïve patients with virologic failure showed >20-fold reduced susceptibility to emtricitabine. Genotypic analysis of these isolates showed that the resistance was due to M184V/I mutations in the HIV RT gene.

Tenofovir DF: The K65R and K70E substitutions selected by tenofovir are also selected in some HIV-1-infected patients treated with abacavir or didanosine. HIV-1 isolates with the K65R and K70E substitutions also showed reduced susceptibility to emtricitabine and lamivudine. Therefore, cross-resistance among these NRTIs may occur in patients whose virus harbors the K65R or K70E substitutions. HIV-1 isolates with reduced susceptibility to tenofovir have been selected in vitro. These viruses expressed a K65R mutation in RT and showed a 2–4 fold reduction in susceptibility to tenofovir.

Tenofovir-resistant isolates of HIV-1 have also been recovered from some patients treated with VIREAD in combination with certain antiretroviral agents. In treatment-naïve patients, 7/29 (24%) isolates from patients failing VIREAD + lamivudine + efavirenz at 48 weeks showed >1.4 fold (median 3.4) reduced susceptibility in vitro to tenofovir.

In treatment-experienced patients, 14/304 (4.6%, studies 902 and 907) isolates from patients failing VIREAD at 96 weeks showed >1.4 fold (median 2.7) reduced susceptibility to tenofovir. Genotypic analysis of the resistant isolates showed a mutation in the HIV-1 RT gene resulting in the K65R amino acid substitution.

iPrEx Trial: In a clinical study of HIV-1 seronegative subjects (**iPrEx Trial**, see **CLINICAL TRIALS**), no mutations associated with resistance to emtricitabine or tenofovir were detected at the time of seroconversion among 48 subjects in the TRUVADA group and 83 subjects in the placebo group who became infected with HIV-1 during the trial. Ten subjects were observed to be HIV-1 infected at time of enrollment. The M184V/I substitutions associated with resistance to emtricitabine were observed in 3 of the 10 subjects (2 of 2 in the TRUVADA group and 1 of 8 in the placebo group). One of the two subjects in the TRUVADA group harbored wild type virus at enrollment and developed the M184V substitution 4 weeks after enrollment. The other subject had indeterminate resistance at enrollment but was found to have the M184I substitution 4 weeks after enrollment.

Partners PrEP Trial: In a clinical study of HIV-1 seronegative subjects (**Partners PrEP Trial**, see **CLINICAL TRIALS**), no variants expressing amino acid substitutions associated with resistance to emtricitabine or tenofovir were detected at the time of seroconversion among 12 subjects in the TRUVADA group, 15 subjects in the VIREAD group, and 51 subjects in the placebo group. Fourteen subjects were observed to be HIV-1 infected at the time of enrollment (3 in the TRUVADA group, 5 in the VIREAD group, and 6 in the placebo group). One of the three subjects in the TRUVADA group who was infected with wild type

virus at enrollment selected an M184V expressing virus by week 12. Two of the five subjects in the VIREAD group had tenofovir-resistant viruses at the time of seroconversion; one subject infected with wild type virus at enrollment developed a K65R substitution by week 16, while the second subject had virus expressing the combination of D67N and K70R substitutions upon seroconversion at week 60, although baseline virus was not genotyped and it is unclear if the resistance emerged or was transmitted. Following enrollment, 4 subjects (2 in the VIREAD group, 1 in the TRUVADA group, and 1 in the placebo group) had virus expressing K103N or V106A substitutions, which confer high-level resistance to NNRTIs but have not been associated with tenofovir or emtricitabine and may have been present in the infecting virus.

Cross-resistance

Emtricitabine and tenofovir DF: Cross-resistance among certain nucleoside reverse transcriptase inhibitors (NRTIs) has been recognized. The M184V/I and/or K65R or K70E substitutions selected in vitro by the combination of emtricitabine and tenofovir are also observed in some HIV-1 isolates from subjects failing treatment with tenofovir in combination with either lamivudine or emtricitabine, and either abacavir or didanosine. Therefore, cross-resistance among these drugs may occur in patients whose virus harbors either or both of these amino acid substitutions.

Emtricitabine: Emtricitabine-resistant isolates (M184V/I) were cross-resistant to lamivudine and zalcitabine but retained susceptibility in vitro to didanosine, stavudine, tenofovir, zidovudine, and NNRTIs (delavirdine, efavirenz, and nevirapine). Isolates from heavily treatment-experienced patients containing the M184V/I amino acid substitution in the context of other NRTI resistance-associated substitutions may retain susceptibility to tenofovir. HIV-1 isolates containing the K65R substitution, selected in vivo by abacavir, didanosine, tenofovir, and zalcitabine, demonstrated reduced susceptibility to inhibition by emtricitabine. Viruses harboring mutations conferring reduced susceptibility to stavudine and zidovudine (M41L, D67N, K70R, L210W, T215Y/F, K219Q/E) or didanosine (L74V) remained sensitive to emtricitabine. HIV-1 containing the K103N substitution associated with resistance to NNRTIs was susceptible to emtricitabine.

Tenofovir DF: HIV-1 isolates from patients (N=20) whose HIV-1 expressed a mean of 3 zidovudine-associated RT amino acid substitutions (M41L, D67N, K70R, L210W, T215Y/F, or K219Q/E/N) showed a 3.1-fold decrease in the susceptibility to tenofovir. Multinucleoside resistant HIV-1 with a T69S double insertion mutation in the RT showed reduced susceptibility to tenofovir.

NON-CLINICAL TOXICOLOGY

Toxicology

Tenofovir and tenofovir DF administered in toxicology studies to rats, dogs and monkeys at exposures (based on AUCs) greater than or equal to 6-fold those observed in humans caused bone toxicity. In monkeys the bone toxicity was diagnosed as osteomalacia. Osteomalacia observed in monkeys appeared to be reversible upon dose reduction or discontinuation of tenofovir. In rats and dogs, the bone toxicity manifested as reduced bone mineral density. The mechanism(s) underlying bone toxicity is unknown.

Evidence of renal toxicity was noted in 4 animal species. Increases in serum creatinine, BUN, glycosuria, proteinuria, phosphaturia, and/or calciuria and decreases in serum phosphate were observed to varying degrees in these animals. These toxicities were noted at exposures (based on AUCs) 2–20 times higher than those observed in humans. The relationship of the renal abnormalities, particularly the phosphaturia, to the bone toxicity is not known.

Carcinogenesis

Emtricitabine: In long-term oral carcinogenicity studies of emtricitabine, no drug-related increase in tumor incidence was found in mice at doses up to 750 mg/kg/day (26 times the human systemic exposure at the therapeutic dose of 200 mg/day) or in rats at doses up to 600 mg/kg/day (31 times the human systemic exposure at the therapeutic dose).

Tenofovir DF: Long-term oral carcinogenicity studies were conducted in mice and rats receiving tenofovir DF. At the high dose in female mice, liver adenomas were increased at exposures 16 times that in humans. In the mouse study, (60/sex/group), one male and two female mice in the 600 mg/kg/day group (15 times the human systemic exposure at the recommended human dose of 300 mg/day) developed duodenal tumors. The mechanism underlying this effect is uncertain but may relate to high local drug concentrations in the gastrointestinal tract. No treatment-related tumors were seen in mice in the 100 or 300 mg/kg/day groups. In the rat study (60/sex/group) at doses of 30, 100, and 300 mg/kg/day (approximately 5 times human exposure), no treatment-related increase in tumor incidence was observed.

Mutagenesis

Emtricitabine: Emtricitabine was not genotoxic in the reverse mutation bacterial test (Ames test), mouse lymphoma or mouse micronucleus assays.

Tenofovir DF: Tenofovir DF was negative in the in vitro bacterial mutation (Ames) assay (*Salmonella-Escherichia coli*/Mammalian-Microsome Reverse Mutation Assay) but positive in the in vitro mouse lymphoma assay (L5178Y TK +/- Forward Mutation Assay), with and without metabolic activation. Tenofovir DF was negative in the in vivo mouse micronucleus assay at plasma exposure levels of more than 10× the human exposure.

Impairment of Fertility

Emtricitabine: Emtricitabine did not affect fertility in male rats at approximately 140-fold or in male and female mice at approximately 60-fold higher exposures (AUC) than in humans given the recommended 200 mg daily dose. Fertility was normal in the offspring of mice exposed daily from before birth (in utero) through sexual maturity at daily exposures (AUC) of approximately 60-fold higher than human exposures at the recommended 200 mg daily dose.

Tenofovir DF: Reproductive toxicity was evaluated in rats and rabbits. Tenofovir DF had no adverse effects on fertility or general reproductive performance in rats at doses up to 600 mg/kg/day. Tenofovir DF had no adverse effects on embryo-fetal development in rats at doses 450 mg/kg/day and in rabbits at doses up to 300 mg/kg/day. In a study of effects on peri- and postnatal development in rats, effects considered due to maternal toxicity (450–600 mg/kg/day) were reduced survival and a slight delay in sexual maturation in the F1 generation. There were no adverse effects on growth, development, behavior, or reproductive parameters at non-maternally toxic doses (150 mg/kg/day).

Pregnancy

Emtricitabine: The incidence of fetal variations and malformations was not increased in embryofetal toxicity studies performed with emtricitabine in mice at exposures (AUC) approximately 60-fold higher and in rabbits at approximately 120-fold higher than human exposures at the recommended daily dose.

Tenofovir DF: Reproduction studies have been performed in rats and rabbits at doses up to 14 and 19 times the human dose based on body surface area comparisons and revealed no evidence of impaired fertility or harm to the fetus due to tenofovir. Reduced pup body weights, survival and delay in sexual maturation was observed in a peri- and postnatal toxicity study in rats at the maternally toxic doses of 450 and 600 mg/kg (approximately 14 and 19 times the human dose based on body surface area comparisons).

Antiretroviral Pregnancy Registry

To monitor fetal outcomes of pregnant women exposed to ART (antiretroviral therapy) including TRUVADA, an Antiretroviral Pregnancy Registry has been established. Healthcare providers are encouraged to register patients by calling 800–258–4263.

REFERENCES

1. Deeks SG, Barditch-Crovo P, Lietman PS, Hwang F, Cundy KC, Rooney JF, et al. Safety, pharmacokinetics, and antiretroviral activity of intravenous 9-[2-(R)-(phosphonomethoxy)propyl]adenine, a novel anti-human immunodeficiency virus (HIV) therapy, in HIV-infected adults. *Antimicrob Agents Chemother* 1998 Sep;42 (9):2380-4.
2. Barditch-Crovo P, Deeks SG, Collier A, Safrin S, Coakley DF, Miller M, et al. Phase I/II trial of the pharmacokinetics, safety, and antiretroviral activity of tenofovir disoproxil fumarate in HIV-1 infected adults. *Antimicrob Agents Chemother* 2001 Oct;45 (10):2733-9.
3. Schooley RT, Ruane P, Myers RA, Beall G, Lampiris H, Berger D, et al. Tenofovir DF in antiretroviral-experienced patients: results from a 48-week, randomized, double-blind study. *AIDS* 2002 Jun 14;16 (9):1257-63.
4. Margot NA, Isaacson E, McGowan I, Cheng AK, Schooley RT, Miller MD. Genotypic and phenotypic analyses of HIV-1 in antiretroviral-experienced patients treated with tenofovir DF. *AIDS* 2002 Jun 14;16 (9):1227-35.
5. Gallant, J.E., DeJesus, E., Arribas, J.R., Pozniak, A.L., Gazzard, B., Campo, R.E. et al. Tenofovir DF, Emtricitabine and Efavirenz versus Zidovudine, Lamivudine and Efavirenz for HIV. *New Engl. J. Med.* 2006 (354): 251-260.
6. EMEA Public Statement, Efficacy and safety concerns regarding the co-administration of tenofovir disoproxil fumarate (TDF, Viread) and didanosine (ddI, Videx), 2005. <http://www.emea.eu.int/pdfs/human/press/pus/6233105en.pdf>.
7. Podzamczar D, Ferrer E, Gatell JM, Niubo J, Dalmau D, Leon A, Knobel H, Polo C, Iniguez D, Ruiz I. Early virological failure with a combination of tenofovir, didanosine and efavirenz. *Antiviral Therapy* 2005; 10: 171-177.
8. Benaboud, S., et al. 2011. Concentrations of Tenofovir and Emtricitabine in Breast Milk of HIV-1 Infected Women in Abidjan, Côte d'Ivoire, in the ANRS 12109 TEMAA Study, Step 2. *Antimicrob. Agents Chemother.* 55: 1315-1317.
9. Baeten J, Donnell D, Ndase P, Mugo N, Campbell J, Wangisi J, et al. Antiretroviral prophylaxis for HIV prevention in heterosexual men and women. *N Engl J Med* 2012;367 (5):399-410.
10. Grant RM, Lama JR, Anderson PL, McMahan V, Liu AY, Vargas L, et al. Preexposure Chemoprophylaxis for HIV Prevention in Men Who Have Sex with Men. *N Engl J Med* 2010;363 (27):2587-99.

PART III. CONSUMER INFORMATION

Pr **TRUVADA**[®] (emtricitabine/tenofovir disoproxil fumarate) tablets

This leaflet is Part III of a three part “Product Monograph” published when TRUVADA was approved for sale in Canada and is designed specifically for consumers. This leaflet is a summary and will not tell you everything about TRUVADA. Contact your healthcare professional if you have any questions about the drug.

ABOUT THIS MEDICATION

What the medication is used for:

TRUVADA is a type of medicine called an HIV (human immunodeficiency virus) nucleoside analog reverse transcriptase inhibitor (NRTI). TRUVADA contains 2 medicines, EMTRIVA[®] (emtricitabine) and VIREAD[®] (tenofovir disoproxil fumarate, or tenofovir DF) combined in one pill.

TRUVADA is used:

- **To treat HIV-1 Infection** when used with other anti-HIV medicines in adults.
- OR
- **To help reduce the risk of getting HIV-1 infection** when used with safer sex practices in:
 - HIV-1 negative men who have sex with men, who are at high risk of getting infected with HIV-1 through sex.
 - Male-female sex partners when one partner has HIV-1 infection and the other does not.
- This is sometimes called Pre-Exposure Prophylaxis or PrEP. For more information on TRUVADA for PrEP, log onto www.truvada.ca.
- TRUVADA is for adults age 18 and older. TRUVADA is not indicated in children under age 18 or adults over age 65.

What it does:

- **Use of TRUVADA to treat HIV-1 infection:**
When used with other HIV-1 medicines to treat HIV-1 infection, TRUVADA helps block HIV reverse transcriptase, a chemical in your body (enzyme) that is needed for HIV to multiply. TRUVADA lowers the amount of HIV in the blood (viral load). Lowering the amount of HIV in the blood lowers the chance of infections that happen when your immune system is weak (opportunistic infections).

HIV infection destroys CD4+ (T) cells, which are important to the immune system. The immune system helps fight infection. After a large number of T cells are destroyed, acquired immune deficiency syndrome (AIDS) develops. TRUVADA may also help to increase the number of T cells (CD4+ cells).

TRUVADA does not cure HIV-1 infection or AIDS. If you have HIV-1 infection, you must stay on continuous HIV therapy to control HIV infection and decrease HIV-related illnesses.

People taking TRUVADA may still get opportunistic infections or other conditions that happen with HIV infection. Opportunistic infections are infections that develop because the immune system is weak. Some of these conditions are pneumonia, herpes virus infections, and *Mycobacterium avium* complex (MAC) infections.

- **Use of TRUVADA to reduce the risk of HIV-1 infection (PrEP indication):**
When used with safer sex practices, TRUVADA may help to reduce the risk of getting HIV-1 infection:
 - TRUVADA works better to reduce the risk of getting HIV-1 when the medicines are in your bloodstream **before** you are exposed to HIV-1.

It is very important that you see your healthcare professional regularly while taking TRUVADA.

Considerations when TRUVADA is used for PrEP:

- Together with your healthcare professional, you need to decide whether TRUVADA is right for you.
- TRUVADA can only help reduce your risk of getting HIV-1 **before** you are infected.
- Do not take TRUVADA to help reduce your risk of getting HIV-1 if:
 - you already have HIV-1 infection. If you are HIV-1 positive, you need to take other medicines with TRUVADA to treat HIV-1. TRUVADA by itself is not a complete treatment for HIV-1.
 - you do not know your HIV-1 infection status. You may already be HIV-1 positive. You need to take other HIV-1 medicines with TRUVADA to treat HIV-1.
- Your healthcare professional will run tests to determine that you are HIV- negative before starting PrEP treatment.

When it should not be used:

Do not use TRUVADA if:

- You are allergic (hypersensitive) to any of the ingredients in this formulation (see: **What the medicinal ingredients are; What the important nonmedicinal ingredients are**)
- Do not use TRUVADA to reduce the risk of getting HIV if you already have HIV or do not know your HIV status.

What the medicinal ingredients are:

emtricitabine
tenofovir disoproxil fumarate (tenofovir DF)

What the important nonmedicinal ingredients are:

croscarmellose sodium, lactose monohydrate, magnesium stearate, microcrystalline cellulose, pregelatinized starch, FD&C blue #2, hypromellose, titanium dioxide and triacetin.

What dosage forms it comes in:

TRUVADA is available as tablets. Each tablet contains 200 mg of emtricitabine and 300 mg of tenofovir disoproxil fumarate (which is equivalent to 245 mg of tenofovir disoproxil), as active ingredients. The tablets are blue, capsule-shaped, film-coated, and debossed with “GILEAD” on one side and with “701” on the other side. Each bottle contains 30 tablets and a desiccant (silica gel canister or sachet) and is closed with a child-resistant closure.

WARNINGS AND PRECAUTIONS

Serious Warnings and Precautions

- The most serious possible side effect is harm to the kidneys, including damage to kidney cells, kidney tissue inflammation and kidney failure. Your healthcare professional may monitor your kidney function before beginning and while receiving TRUVADA. Some patients treated with tenofovir DF (a component of TRUVADA) have had kidney problems. Your healthcare professional may need to perform additional blood tests if you have had kidney problems in the past or need to take another drug that can cause kidney problems.
- **If you are also infected with the Hepatitis B Virus, “flare-ups” of Hepatitis B Virus infection**, in which the disease suddenly returns in a worse way than before, can occur if you stop taking TRUVADA. Do not stop taking TRUVADA without your healthcare professional’s advice. If you stop taking TRUVADA, tell your healthcare professional immediately about any new, unusual or worsening symptoms that you notice after stopping treatment. After you stop taking TRUVADA, your healthcare professional will still need to check your health and take blood tests to check your liver for several months. TRUVADA is not approved for the treatment of Hepatitis B Virus infection.
- The class of medicines to which TRUVADA belongs (NRTIs) can cause a condition called lactic acidosis, together with an enlarged liver. Non-specific symptoms such as nausea, vomiting and stomach pain might indicate the development of lactic acidosis. This rare but serious side effect has occasionally been fatal. Lactic acidosis occurs more often in women, particularly if they are very overweight. You should consult your healthcare professional immediately if such symptoms occur while you are receiving TRUVADA. The symptoms that may indicate lactic acidosis include: feeling very weak, tired or uncomfortable; unusual or unexpected stomach discomfort; feeling cold; feeling dizzy or lightheaded; suddenly developing a slow or irregular heartbeat. If you notice these symptoms, stop taking TRUVADA and consult a healthcare professional immediately.
- Tenofovir DF caused harm to the bones of animals. Tenofovir DF reduced bone density in humans. If you notice bone pain, or suffer a bone fracture, or other bone problem, consult your healthcare professional. If you have bone problems, you may wish to discuss calcium and/or vitamin D supplements with your healthcare professionals.

- TRUVADA should only be used for the PrEP indication if you are HIV-negative before and during treatment. Discuss with your healthcare professional if you have had a recent flu-like illness. Your healthcare professional will run tests to confirm that you are HIV negative before and during TRUVADA treatment.

Do NOT take TRUVADA if:

- you are on other medications that may affect your kidneys and have not discussed this with your healthcare professional.
- you have or are at known risk for any type of bone disease or bone related problems and have not discussed this with your healthcare professional.
- you are allergic to TRUVADA or any of its ingredients. The medicinal ingredients are emtricitabine and tenofovir DF (see: **What the important nonmedicinal ingredients are**).
- you are already taking 3TC[®], ATRIPLA[®], Combivir[®], COMPLERA[®], DESCOVY[®], EMTRIVA[®], GENVOYA[®], ODEFSEY[™], Heptovir[®], Kivexa[®], STRIBILD[®], Trumeq[®], Trizivir[®], VEMLIDY[™], or VIREAD[®] because these medicines contain the same or similar active ingredients
- you are also taking HEPSERA[®] to treat your HBV infection

Changes in your immune system (Immune Reconstitution Inflammatory Syndrome) can happen when an HIV-1 infected person starts taking HIV medicines. Your immune system may get stronger and begin to fight infections that have been hidden in your body for a long time, or you could develop an autoimmune disease in which your immune system reacts against your own body [e.g. Grave’s disease (which affects the thyroid gland), Guillain-Barré syndrome (which affects the nervous system) or polymyositis (which affects the muscles)] and it may develop at any time, sometimes months later after the start of HIV therapy. Sometimes symptoms can be severe, so if you develop high temperature (fever), joint or muscle pain, redness, rash, swelling or fatigue, or any new symptoms, contact your healthcare professional right away.

Before taking TRUVADA to reduce your risk of getting HIV-1 infection (PrEP indication):

- **You must get tested to be sure you are HIV-negative.** It is important that you also get tested at least every 3 months as recommended by your healthcare provider while taking TRUVADA. **Do not take TRUVADA to reduce the risk of getting HIV (PrEP) unless you are confirmed to be HIV-negative.**
- Tell your healthcare provider if you have any of the following symptoms within the last month before you start taking TRUVADA or at any time while taking TRUVADA:
 - tiredness
 - fever
 - sweating a lot (especially at night)
 - rash

- vomiting or diarrhea
- joint or muscle aches
- headache
- sore throat
- enlarged lymph nodes in the neck or groin

These may be signs of HIV infection and you may need to have a different kind of test to diagnose HIV. If you are already taking TRUVADA to prevent HIV-1 infection (PrEP), your healthcare provider may tell you to stop taking TRUVADA until an HIV test confirms that you do not have HIV-1 infection. For more information on TRUVADA for PrEP, log onto www.truvada.ca.

Just taking TRUVADA may not keep you from getting HIV. TRUVADA does NOT always prevent HIV.

You must still practice safer sex at all times. Do not have any kind of sex without protection. Always practice safer sex by using a latex or polyurethane condom to lower the chance of sexual contact with semen, vaginal secretions, or blood.

You must also use other prevention methods to keep from getting HIV.

- Know your HIV-1 status and the HIV-1 status of your partners.
- While taking TRUVADA, get tested at least every 3 months for HIV, as recommended by your healthcare provider. Ask your partners to get tested.
- If you think you were exposed to HIV-1, tell your healthcare provider right away. They may want to do more tests to be sure you are still HIV-negative.
- Get tested for other sexually transmitted infections such as syphilis and gonorrhea. These infections make it easier for HIV to infect you.
- Get information and support to help reduce risky sexual behavior.
- Have fewer sex partners.
- Do not miss any doses of TRUVADA. Missing doses may increase your risk of getting HIV-1 infection.

BEFORE you use TRUVADA (emtricitabine/tenofovir DF) talk to your healthcare professional:

If you are pregnant or planning to become pregnant: Pregnant mothers should not take TRUVADA unless specifically directed by the healthcare professional.

If you are a female who is taking TRUVADA to prevent HIV infection (PrEP) and you become pregnant while taking TRUVADA, talk to your healthcare provider about whether you should continue taking TRUVADA.

Pregnancy Registry. There is a pregnancy registry for women who take antiviral medicines during pregnancy. The purpose of this registry is to collect information about the health of you and your baby. Talk to your healthcare provider about how you can

take part in this Antiretroviral Pregnancy Registry.

If you are breastfeeding or planning to breastfeed: Do not breastfeed if you are taking TRUVADA or have HIV. Emtricitabine and tenofovir DF, the two components of TRUVADA, pass to your baby in your breast milk. You should not breastfeed because of the risk of passing HIV to your baby. Talk to your healthcare professional about the best way to feed your baby.

If you have other medical conditions: Let your healthcare professional know if you have other medical conditions, especially liver, bone and kidney problems.

If you are taking other medicines: Some medicines can interact when taken together, including prescription and non-prescription medicines and dietary supplements (see **INTERACTIONS WITH THIS MEDICATION**).

If you are taking didanosine: Taking didanosine and Truvada may cause serious reactions including lactic acidosis (too much acid in the blood), pancreatitis (inflamed pancreas) and nerve damage (neuropathy) (see **INTERACTIONS WITH THIS MEDICATION and SIDE EFFECTS AND WHAT TO DO ABOUT THEM**).

Truvada should not be used with or soon after cidofovir, acyclovir, valacyclovir, ganciclovir, valganciclovir, aminoglycosides, or nonsteroidal anti-inflammatory drugs (NSAIDs), due to potential harm to the kidneys.

It is a good idea to keep a complete list of all the medicines that you take. Make a new list when medicines are added or stopped. Give copies of this list to all of your healthcare providers every time you visit your healthcare professional or fill a prescription.

Other Special Warnings:

Your blood sugar levels (glucose) or levels of fats (lipids) in your blood may increase with HIV treatment. Your doctor may order blood tests for you.

INTERACTIONS WITH THIS MEDICATION

Let your healthcare professional know if you are taking these or any other medications:

- Drugs that contain didanosine (Videx[®], Videx EC[®]). Tenofovir DF (a component of TRUVADA) may increase the amount of Videx in your blood. You may need to be followed more carefully if you are taking TRUVADA and Videx together. Also, the dose of didanosine may need to be reduced.
- Reyataz[®] (atazanavir sulfate), Kaletra[®] (lopinavir/ritonavir), Prezista[®] (darunavir), HARVONI[®] (ledipasvir/sofosbuvir), EPCLUSA[®] (sofosbuvir/velpatasvir) or VOSEVI[™] (sofosbuvir/velpatasvir/voxilaprevir). These medicines may increase the amount of tenofovir DF (a component of TRUVADA) in your blood, which could result in more side effects. You may need to be followed more carefully if you

are taking TRUVADA together with Reyataz, Kaletra, Prezista, HARVONI, EPCLUSA or VOSEVI. TRUVADA may decrease the amount of Reyataz in your blood. If you are taking TRUVADA and Reyataz together, you should also be taking Norvir® (ritonavir).

- Non-steroidal anti-inflammatory drugs.

PROPER USE OF THIS MEDICATION

Stay under a healthcare professional's care when taking TRUVADA. **Do not change your treatment or stop treatment without first talking with your healthcare professional.**

Take TRUVADA exactly as your healthcare professional prescribed it. Follow the directions from your healthcare professional, exactly as written on the label. Set up a dosing schedule and follow it carefully.

When used to treat HIV-1 infection, TRUVADA is always used with other HIV-1 medicines.

If you take TRUVADA to reduce your risk of getting HIV-1:

- you must also use other methods to reduce your risk of getting HIV.
- **take TRUVADA every day**, not just when you think you have been exposed to HIV-1.

Avoid doing things that can increase your risk of getting HIV infection or spreading HIV infection to other people:

- Do not re-use or share needles or other injection equipment.
- Do not share personal items that can have blood or body fluids on them, like toothbrushes and razor blades.
- Do not have any kind of sex without protection. Always practice safer sex by using a latex or polyurethane condom to lower the chance of sexual contact with semen, vagina secretions, or blood.

Ask your healthcare provider if you have any questions on how to prevent getting HIV infection or spreading HIV infection to other people.

When your TRUVADA supply starts to run low, get more from your healthcare professional. This is very important because the amount of virus in your blood may increase if the medicine is stopped for even a short time. The virus may develop resistance to TRUVADA and become harder to treat.

Only take medicine that has been prescribed specifically for you. Do not give TRUVADA to others or take medicine prescribed for someone else.

Do not use if seal over bottle opening is broken or missing.

Usual Adult Dose:

For the treatment of HIV-1 infection:

- The usual dose of TRUVADA is one tablet orally (by

mouth) once a day, in combination with other anti-HIV medicines.

- TRUVADA may be taken with or without a meal.

For prevention of HIV-1 infection (PrEP):

- The usual dose of TRUVADA is one tablet orally (by mouth) once a day.
- TRUVADA may be taken with or without a meal.

Overdosage:

In case of drug overdose, contact your healthcare professional, hospital emergency department or Regional Poison Control Centre, even if there are no symptoms.

Missed Dose:

It is important that you do not miss any doses. If you miss a dose of TRUVADA and it is less than 12 hours from the time you usually take TRUVADA, then take the dose. If more than 12 hours has passed from the time you usually take TRUVADA, then wait until the next scheduled daily dose. **Do not** take more than 1 dose of TRUVADA in a day. **Do not** take 2 doses at the same time. Call your healthcare professional if you are not sure what to do.

SIDE EFFECTS AND WHAT TO DO ABOUT THEM

The most common side effects of TRUVADA are:

- Diarrhea
- Nausea
- Vomiting
- Dizziness
- Headache

Other side effects include:

- Stomach pain
- Indigestion
- Inflammation of the pancreas
- Sleeping problems
- Abnormal dreams
- Weakness
- Pain
- Shortness of breath
- Allergic reaction (including swelling of the face, lips, tongue or throat)
- Rash
- Flatulence (intestinal gas)
- Skin discoloration (small spots or freckles) may also happen with TRUVADA

SERIOUS SIDE EFFECTS, HOW OFTEN THEY HAPPEN AND WHAT TO DO ABOUT THEM			
Symptoms/Effect	Talk with your healthcare professional		Stop taking drug and call your healthcare professional
	Only if severe	In all cases	

Rare	<p>Effect: Kidney problems</p> <p>Symptoms</p> <ul style="list-style-type: none"> You may have increased or decreased urination as well as increased thirst You may have swelling of your legs and feet You may feel listless and tired 		✓	
Rare	<p>Effect: Lactic acidosis</p> <p>Symptoms</p> <ul style="list-style-type: none"> Feeling very weak or tired Unusual muscle pain Stomach pain with nausea and vomiting Feeling cold, especially in arms and legs Feeling dizzy or lightheaded Fast or irregular heartbeat 		✓ ✓ ✓ ✓ ✓ ✓	
Very Rare	<p>Effect: Hepatotoxicity (severe liver problems) with hepatomegaly (liver enlargement) and steatosis (fat in the liver)</p> <p>Symptoms</p> <ul style="list-style-type: none"> Jaundice (skin or the white part of eyes turns yellow) Urine turns dark Bowel movements (stools) turn light in color Loss of appetite for several days or longer Feeling sick to your stomach (nausea) Lower stomach pain 		✓ ✓ ✓ ✓ ✓ ✓	
Very Rare	<p>Effect: Flare-ups of hepatitis B virus infection following drug discontinuation</p> <p>Symptoms</p> <ul style="list-style-type: none"> Jaundice (skin or the white part of eyes turns yellow) Urine turns dark Bowel movements (stools) turn light in color Loss of appetite for several days or 		✓ ✓ ✓ ✓	

	longer			
	• Feeling sick to your stomach (nausea)		✓	
	• Lower stomach pain		✓	

Lactic acidosis is a medical emergency and must be treated in the hospital. You may be more likely to get lactic acidosis or serious liver problems if you are very overweight (obese) or have been taking nucleoside analog medicines, like TRUVADA, for a long time.

Muscle pain, muscle weakness, bone pain and softening of the bone (infrequently contributing to fractures) have also been reported.

There have been other side effects in patients taking EMTRIVA or VIREAD. *This is not a complete list of side effects.* If you have questions about side effects, ask your healthcare professional. You should report any new or continuing symptoms to your healthcare professional right away. Your healthcare professional may be able to help you manage these side effects.

HOW TO STORE IT

- Keep TRUVADA and all other medications out of reach and sight of children.
- TRUVADA should be stored at 15–30 °C (59–86 °F). It should remain stable until the expiration date printed on the label.
- Do not keep your medicine in places that are too hot or cold.
- Do not keep medicine that is out of date or that you no longer need. If you throw any medicines away, make sure that children will not find them.
- Keep TRUVADA in its original container and keep the container tightly closed.

MORE INFORMATION

This document plus the full Product Monograph, prepared for healthcare professionals, can be found at: www.gilead.ca or by contacting the sponsor, Gilead Sciences Canada, Inc., at: 1- 866-207- 4267

This leaflet was prepared by Gilead Sciences Canada, Inc.

Last revised: July 5, 2018

Gilead Sciences, Inc.
Foster City, CA 94404
USA

Gilead Sciences Canada, Inc.
Mississauga, ON
L5N 2W3

ATRIPLA[®], COMPLERA[®], DESCOVY[®], EMTRIVA[®], GENVOYA[®], HARVONI[®], EPCLUSA[®], ODEFSEY[™], HEPSERA[®], SOVALDI[®], STRIBILD[®], TRUVADA[®], VEMLIDY[™], VIREAD[®] and VOSEVI[™] are trademarks of Gilead Sciences, Inc. or its related companies.

All other trademarks referenced herein are the property of their owners.

© 2017 Gilead Sciences, Inc. All rights reserved.



e133222-GS-017

REPORTING SUSPECTED SIDE EFFECTS

You can report any suspected adverse reactions associated with the use of health products to the Canada Vigilance Program by one of the following 3 ways:

- **Report online at www.canada.ca/en/health-canada/services/drugs-health-products/medeffect-canada**
- **Call toll-free at 1-866-234-2345**
- **Complete a Canada Vigilance Reporting Form and:**
 - Fax toll-free to 1-866-678-6789, or
 - Mail to: Canada Vigilance Program
Health Canada
Postal Locator 1908C
Ottawa, ON K1A 0K9

Postage paid labels, Canada Vigilance Reporting Form and the adverse reaction reporting guidelines are available on the Medeffect[™] Canada Web site at www.canada.ca/en/health-canada/services/drugs-health-products/medeffect-canada.

NOTE: Should you require information related to the management of side effects, contact your health care professional. The Canada Vigilance Program does not provide medical advice.

PRODUCT MONOGRAPH
INCLUDING PATIENT MEDICATION INFORMATION

Pr **UPTRAVI**[®]

Selexipag Film-coated tablets

200 mcg, 400 mcg, 600 mcg, 800 mcg, 1000 mcg, 1200 mcg, 1400 mcg, and 1600 mcg

Professed standard

Prostacyclin (PGI₂) receptor (IP receptor) agonist

Janssen Inc
19 Green Belt Drive
Toronto, Ontario
M3C 1L9

Date of Revision:
June 19, 2020

www.janssen.com/canada

Submission Control No.: 229725

© 2020 Janssen Inc.

All trademarks used under license.

Table of Contents

PART I: HEALTH PROFESSIONAL INFORMATION.....3
SUMMARY PRODUCT INFORMATION3
INDICATIONS AND CLINICAL USE.....3
CONTRAINDICATIONS4
WARNINGS4
ADVERSE REACTIONS.....6
DRUG INTERACTIONS8
DOSAGE AND ADMINISTRATION11
OVERDOSAGE12
ACTION AND CLINICAL PHARMACOLOGY12
STORAGE AND STABILITY15
DOSAGE FORMS, COMPOSITION AND PACKAGING15

PART II: SCIENTIFIC INFORMATION17
PHARMACEUTICAL INFORMATION.....17
CLINICAL TRIALS18
DETAILED PHARMACOLOGY27
TOXICOLOGY27
REFERENCES30

PART III: PATIENT MEDICATION INFORMATION31

Pr UPTRAVI®

Selexipag (film-coated) tablets

PART I: HEALTH PROFESSIONAL INFORMATION

SUMMARY PRODUCT INFORMATION

Table 1: Product Information Summary

Route of Administration	Dosage Form / Strength	All Nonmedicinal Ingredients
Oral	Tablet / 200 mcg, 400 mcg, 600 mcg, 800 mcg, 1000 mcg, 1200 mcg, 1400 mcg, and 1600 mcg	For a complete listing see Dosage Forms, Composition and Packaging section.

INDICATIONS AND CLINICAL USE

UPTRAVI® is indicated for the long-term treatment of idiopathic pulmonary arterial hypertension (iPAH), heritable pulmonary arterial hypertension (HPAH), PAH associated with connective tissue disorders and PAH associated with congenital heart disease, in adult patients with WHO functional class (FC) II–III to delay disease progression. Disease progression included: hospitalization for PAH, initiation of intravenous or subcutaneous prostanoids, or other disease progression events (decrease of 6-minute walk distance [6MWD] associated with either worsened PAH symptoms or need for additional PAH-specific treatment) (see **ACTION AND CLINICAL PHARMACOLOGY, Pharmacodynamics**).

UPTRAVI® is effective in combination with an endothelin receptor antagonist (ERA) or a phosphodiesterase-5 (PDE-5) inhibitor, or in triple combination with an ERA and a PDE-5 inhibitor, or as monotherapy.

Geriatrics (≥ 65 years of age):

Of the total number of subjects in the clinical study of UPTRAVI® for pulmonary arterial hypertension, 18% were 65 years of age and older. There is limited clinical experience in patients over the age of 75 years; therefore, UPTRAVI® should be used with caution in this population (see **WARNINGS AND PRECAUTIONS, Special Populations, Geriatrics**).

Pediatrics (< 18 years of age):

The safety and efficacy of UPTRAVI® in children aged 0 to less than 18 years have not yet been established. No data are available (see **WARNINGS AND PRECAUTIONS, Special Populations, Pediatrics**).

CONTRAINDICATIONS

- Patients who are hypersensitive to this drug or to any ingredient in the formulation or component of the container. For a complete listing, see the **DOSAGE FORMS, COMPOSITION AND PACKAGING** section of the product monograph.
- Concomitant use of strong inhibitors of CYP2C8 (e.g., gemfibrozil) (see **DRUG INTERACTIONS**).

WARNINGS AND PRECAUTIONS

General

Concomitant use with moderate inhibitors or strong inducers of CYP2C8 and strong inhibitors of UGT1A3, and UGT2B7: Caution is required when administering drugs that are moderate inhibitors or strong inducers of CYP2C8 and strong inhibitors of UGT1A3, and UGT2B7 concomitantly with UPTRAVI® (see **DRUG INTERACTIONS**).

Effects on ability to drive and use machines: No studies on the effect of selexipag on the ability to drive and use machines have been performed.

Hepatic/Biliary/Pancreatic

The exposure to selexipag and its active metabolite is increased in subjects with moderate hepatic impairment (Child-Pugh class B; see **ACTION AND CLINICAL PHARMACOLOGY, Pharmacokinetics**). A once daily regimen is recommended in patients with moderate hepatic impairment (Child-Pugh class B) due to the increased exposure to selexipag and its active metabolite in this population. In these patients, the starting dose of UPTRAVI® should be 200 micrograms once daily, and increased at weekly intervals by increments of 200 micrograms given once a day until adverse reactions, reflecting the mode of action of selexipag, that cannot be tolerated or medically managed, are experienced. There is no clinical experience with UPTRAVI® in patients with severe hepatic impairment (Child-Pugh class C), therefore UPTRAVI® should not be used in these patients.

Hypotension

Before prescribing UPTRAVI®, physicians should carefully consider whether patients with certain underlying conditions could be adversely affected by vasodilatory effects (e.g., patients on antihypertensive therapy or with resting hypotension, hypovolaemia, severe left ventricular outflow obstruction or autonomic dysfunction).

Hyperthyroidism

Hyperthyroidism has been observed with UPTRAVI® and other prostacyclin receptor agonists. Thyroid function tests are recommended as clinically indicated.

Pulmonary veno-occlusive disease

Should signs of pulmonary oedema occur, the possibility of pulmonary veno-occlusive disease should be considered. If confirmed, UPTRAVI® should be discontinued.

Renal

In patients with severe renal impairment (estimated glomerular filtration rate [eGFR] < 30 mL/min/1.73 m²) caution should be exercised during dose titration. There is no experience with UPTRAVI[®] in patients undergoing dialysis (see **ACTION AND CLINICAL PHARMACOLOGY, Pharmacokinetics**); therefore UPTRAVI[®] should not be used in these patients.

Special Populations

Pregnant Women: There are limited data on the use of selexipag in pregnant women. Treatment during organogenesis resulted in reduced maternal as well as fetal body weight gain in rats at 14 times (selexipag) and 47 times (active metabolite) above human exposure, but there were no increases in malformations or variations in rats or rabbits (see **TOXICOLOGY**). As a precautionary measure, it is preferable – unless clearly needed – to avoid the use of UPTRAVI[®] during pregnancy.

Nursing Women: It is unknown whether selexipag or its metabolites are excreted in human milk. In rats, selexipag or its metabolites are excreted in milk. Breastfeeding is not recommended during treatment with UPTRAVI[®].

Pediatrics (<18 years of age):

The safety and efficacy of UPTRAVI[®] in children aged 0 to less than 18 years have not been established.

Geriatrics (≥ 65 years of age): Of the total number of subjects in the clinical study of UPTRAVI[®] for pulmonary arterial hypertension, 18% were 65 years of age and older. There is limited clinical experience with selexipag in patients over the age of 75 years; therefore UPTRAVI[®] should be used with caution in this population (see section **DOSAGE AND ADMINISTRATION**).

ADVERSE REACTIONS

Adverse Drug Reaction Overview

The most commonly reported adverse drug reactions related to the pharmacological effects of UPTRAVI® are headache, diarrhoea, nausea and vomiting, jaw pain, myalgia, pain in the extremity, flushing, and arthralgia. These reactions are more frequent during the dose titration phase. The majority of these reactions are of mild to moderate intensity.

Clinical Trial Adverse Drug Reactions

Because clinical trials are conducted under very specific conditions the adverse reaction rates observed in the clinical trials may not reflect the rates observed in practice and should not be compared to the rates in the clinical trials of another drug. Adverse drug reaction information from clinical trials is useful for identifying drug-related adverse events and for approximating rates

The safety of selexipag has been evaluated in a long-term, Phase 3 placebo-controlled study enrolling 1156 patients with symptomatic PAH (*GRIPHON study*). The mean treatment duration was 76.4 weeks (median 70.7 weeks) for patients receiving selexipag versus 71.2 weeks (median 63.7 weeks) for patients on placebo. The exposure to selexipag was up to 4.2 years.

Table 2: Adverse Reactions Reported by >3% of Patients on UPTRAVI® and more frequent than on Placebo §

System Organ Class Preferred Term	UPTRAVI® N=575 Subjects		Placebo N=577 Subjects	
	n	%	n	%
Patients with at least one AE	565	98.3%	559	96.9%
Blood and Lymphatic Disorders				
Anaemia	48	8.3%	31	5.4%
Gastrointestinal Disorders				
Abdominal Discomfort	20	3.5%	14	2.4%
Abdominal Pain	48	8.3%	33	5.7%
Diarrhoea	244	42.4%	106	18.4%
Dyspepsia	25	4.3%	14	2.4%
Nausea	192	33.4%	105	18.2%
Vomiting	104	18.1%	49	8.5%
General Disorders and Administration Site Conditions				
Pain	18	3.1%	3	0.5%
Musculoskeletal and Connective Tissue Disorders				
Arthralgia	62	10.8%	44	7.6%
Musculoskeletal Pain	18	3.1%	12	2.1%
Myalgia	92	16.0%	34	5.9%
Pain In Extremity	97	16.9%	44	7.6%
Pain In Jaw	148	25.7%	33	5.7%

System Organ Class Preferred Term	UPTRAVI® N=575 Subjects		Placebo N=577 Subjects	
	n	%	n	%
Nervous System Disorders				
Headache	375	65.2%	182	31.5%
Skin and Subcutaneous Tissue Disorders				
Rash	26	4.5%	16	2.8%
Vascular Disorders				
Flushing	70	12.2%	28	4.9%
Hypotension	29	5.0%	18	3.1%

§ reported by 3% more in the active group vs placebo and if the adverse event is consistent with the pharmacology of the drug and hence a causal relationship was deemed at least as possible.

Pharmacological effects associated with titration and maintenance treatment: Adverse reactions associated with the pharmacological action of selexipag have been observed frequently, in particular during the phase of individualised dose titration. The placebo-corrected incidence during the titration and maintenance phase, respectively, were: headache (36% and 20%), diarrhoea (24% and 16%), jaw pain (22% and 17%), nausea (16% and 10%), myalgia (10% and 6%), vomiting (10% and 2%), pain in extremity (9% and 7%), flushing (7% and 7%), and arthralgia (2% and 4%). These effects are usually transient or manageable with symptomatic treatment.

Less Common Clinical Trial Adverse Drug Reactions (<3%)

Infections and infestations: Nasopharyngitis

Nervous system disorders: Burning sensation

Endocrine disorders: Hyperthyroidism

Eye disorders: Eye pain

Vascular disorders: Hot flush, orthostatic hypotension

Respiratory, thoracic and mediastinal disorders: Nasal congestion, sinus congestion, nasal obstruction, pulmonary oedema, pulmonary veno-occlusive disease

Gastrointestinal disorders: Dyspepsia, abdominal discomfort, frequent bowel movements, abdominal pain upper, abdominal pain lower, abdominal tenderness

Skin and subcutaneous tissue disorders: Erythema, alopecia, pain of skin

Musculoskeletal and connective tissue disorders: Neck pain, bone pain, musculoskeletal pain, musculoskeletal stiffness, limb discomfort, temporomandibular joint syndrome, trismus

General disorders and administration site conditions: Asthenia

Investigations: Weight decreased, haematocrit decreased, blood iron decreased

Metabolism and Nutrition disorders: Decreased appetite

Abnormal Hematologic and Clinical Chemistry Findings

Haemoglobin

In a Phase 3 placebo-controlled study in patients with PAH, mean absolute changes in

haemoglobin at regular visits compared to baseline ranged from -0.34 to -0.02 g/dL in the selexipag group compared to -0.05 to 0.25 g/dL in the placebo group. A decrease from baseline in haemoglobin concentration to below 10 g/dL was reported in 8.6% of patients treated with selexipag and 5.0% of placebo-treated patients.

Thyroid function tests

In a Phase 3 placebo-controlled study in patients with PAH, a reduction (up to -0.3 MU/L from a baseline median of 2.5 MU/L) in median thyroid-stimulating hormone (TSH) was observed at most visits in the selexipag group. In the placebo group, little change in median values was apparent. There were no mean changes in triiodothyronine or thyroxine in either group.

DRUG INTERACTIONS

Drug-Drug Interactions

In vitro studies

Selexipag is hydrolysed to its active metabolite by carboxylesterases (see **ACTION AND CLINICAL PHARMACOLOGY, Pharmacokinetics**). Selexipag and its active metabolite both undergo oxidative metabolism mainly by CYP2C8 and to a smaller extent by CYP3A4. The glucuronidation of the active metabolite is catalysed by UGT1A3 and UGT2B7. Selexipag and its active metabolite are substrates of OATP1B1 and OATP1B3. Selexipag is a substrate of P-gp, and the active metabolite is a substrate of the transporter breast cancer resistance protein (BCRP).

Selexipag and its active metabolite do not inhibit or induce cytochrome P450 enzymes or transport proteins at clinically relevant concentrations.

In vivo studies

Drug	Level of Evidence	Effect	Clinical comment
PAH-specific therapies	CT	In the Phase 3 placebo-controlled study in patients with PAH, no relevant changes in the exposure (area under the plasma concentration-time curve during a dose interval) to selexipag and its active metabolite were observed when administered in combination with an Endothelin Receptor Antagonist (ERA) and/or a Phosphodiesterase-5 (PDE-5) inhibitor	No dose adjustment is warranted.
Anticoagulants or inhibitors of platelet aggregation	CT	Selexipag is an inhibitor of platelet aggregation <i>in vitro</i> . In the Phase 3 placebo-controlled study in patients with PAH, no increased risk of bleeding was detected with selexipag compared to placebo, including when selexipag was	No dose adjustment is warranted.

Drug	Level of Evidence	Effect	Clinical comment
		administered with anticoagulants (such as heparin, coumadin-type anticoagulants) or inhibitors of platelet aggregation. In a study in healthy subjects, selexipag (400 micrograms twice a day) did not alter the exposure to S-warfarin (CYP2C9 substrate) or R-warfarin (CYP3A4 substrate) after a single dose of 20 mg warfarin. Selexipag did not influence the pharmacodynamic effect of warfarin on the international normalised ratio. The pharmacokinetics of selexipag and its active metabolite were not affected by warfarin.	
Lopinavir / ritonavir	CT	In the presence of 400/100 mg lopinavir/ritonavir twice a day, a strong CYP3A4, OATP (OATP1B1 and OATP1B3) and P-gp inhibitor, exposure to selexipag increased approximately 2-fold, whereas the exposure to the active metabolite of selexipag did not change.	No dose adjustment is warranted.
Inhibitors of CYP2C8	CT	<p>In the presence of 600 mg gemfibrozil, twice a day, a strong inhibitor of CYP2C8, exposure to selexipag increased approximately 2-fold whereas exposure to the active metabolite increased approximately 11-fold (see CONTRAINDICATIONS).</p> <p>Concomitant administration of selexipag with clopidogrel, a moderate inhibitor of CYP2C8, had no relevant effect on the exposure to selexipag and increased the exposure to the active metabolite by approximately 2.2-fold following a single loading dose of clopidogrel (300mg) and 2.7-fold after maintenance doses of clopidogrel (75 mg once a day).</p>	<p>Concomitant administration with gemfibrozil is contraindicated.</p> <p>Dosing frequency of selexipag should be reduced to once daily and tolerance should be closely monitored when co-administered with moderate CYP2C8 inhibitors (e.g., clopidogrel, deferasirox, teriflunomide) (see DOSAGE AND ADMINISTRATION).</p>

Drug	Level of Evidence	Effect	Clinical comment
Rifampicin	CT	In the presence of 600 mg rifampicin, once a day, an inducer of CYP2C8 and UGT enzymes, the exposure to selexipag did not change whereas exposure to the active metabolite was reduced by half.	Dose adjustment may be required with concomitant administration of inducers of CYP2C8 (e.g., rifampicin, rifapentine).
Midazolam	CT	At steady state after up-titration to 1600 µg selexipag twice a day, no change in exposure to midazolam, a sensitive intestinal and hepatic CYP3A4 substrate, or its metabolite, 1-hydroxymidazolam, was observed.	No dose adjustment is warranted.
Inhibitors of UGT1A3, and UGT2B7	T	The effect of strong inhibitors of UGT1A3 and UGT2B7 on the exposure to selexipag or its active metabolite has not been studied. Concomitant administration may result in a significant increase in exposure to selexipag or its active metabolite (see WARNINGS AND PRECAUTIONS, <u>General</u>).	Concomitant administration is not recommended with strong inhibitors of UGT1A3 and UGT2B7 (e.g., valproic acid, and fluconazole). Caution is recommended when administering these drugs concomitantly with selexipag if it cannot be avoided.
Hormonal contraceptives	T	Specific drug-drug interaction studies with hormonal contraceptives have not been conducted. Since selexipag did not affect the exposure to the CYP3A4 substrates midazolam and R-warfarin or the CYP2C9 substrate S-warfarin, reduced efficacy of hormonal contraceptives is not expected.	No dose adjustment is warranted.

CT = Clinical Trial; T = Theoretical

Drug-Food Interactions

Interactions with food have not been established.

Drug-Herb Interactions

Interactions with herbal products have not been established.

Drug-Laboratory Interactions

Interactions with laboratory tests have not been established.

DOSAGE AND ADMINISTRATION

Recommended Dose and Dosage Adjustment

Individualised dose titration

The goal is to reach the individually appropriate dose for each patient (the individualised maintenance dose).

The recommended starting dose of UPTRAVI® is 200 micrograms given twice daily, approximately 12 hours apart. The dose is increased in increments of 200 micrograms given twice daily, usually at weekly intervals, until adverse pharmacological effects that cannot be tolerated or medically managed are experienced, or until a maximum dose of 1600 micrograms twice daily is reached. During dose titration, it is recommended not to discontinue treatment in the event of expected pharmacological side effects, since they are usually transient or manageable with symptomatic treatment (see **ADVERSE REACTIONS**). If a patient reaches a dose that cannot be tolerated, the dose should be reduced to the previous dose level.

Individualised maintenance dose

The highest tolerated dose reached during dose titration should be maintained. If the therapy over time is less tolerated at a given dose, symptomatic treatment or a dose reduction to the next lower dose should be considered.

Administration

The film-coated tablets are to be taken orally in the morning and in the evening. UPTRAVI® may be taken with or without food. Tolerability may be improved when taken with food.

The tablets should not be split, crushed or chewed, and are to be swallowed with water.

Hepatic impairment

No adjustment to the dosing regimen is needed in patients with mild hepatic impairment (i.e., Child-Pugh class A). In patients with moderate hepatic impairment, UPTRAVI® should be dosed once daily (i.e., Child-Pugh class B.) (see **WARNINGS AND PRECAUTIONS**). Do not use the drug in patients with severe hepatic impairment.

Renal impairment

No adjustment to the dosing regimen is needed in patients with mild or moderate renal impairment. No change in starting dose is required in patients with severe renal impairment; dose

titration should be done with caution in these patients (see **WARNINGS AND PRECAUTIONS**).

Geriatrics (≥ 65 years)

No adjustment to the dosing regimen is needed in older patients (see **ACTION AND CLINICAL PHARMACOLOGY, Pharmacokinetics, Special Populations and Conditions**). There is limited clinical experience in patients over the age of 75 years, therefore UPTRAVI[®] should be used with caution in this population (see **WARNINGS AND PRECAUTIONS**).

Paediatric population (< 18 years)

The safety and efficacy of UPTRAVI[®] in children aged 0 to less than 18 years have not been established. No data are available.

Missed Dose

If a dose of medication is missed, it should be taken as soon as possible. The missed dose should not be taken if it is almost time for the next scheduled dose (within approximately 6 hours).

If treatment is missed for 3 days or more, UPTRAVI[®] should be restarted at a lower dose and then titrated.

Dosage adjustment with co-administration of moderate CYP2C8 inhibitors

When co-administered with moderate CYP2C8 inhibitors (e.g., clopidogrel, deferasirox and teriflunomide), reduce the dosing of UPTRAVI[®] to once daily. If the therapy is not tolerated at a given dose, symptomatic treatment and/or a dose reduction to the next lower dose should be considered. Revert back to twice daily dosing frequency of UPTRAVI[®] when co-administration of moderate CYP2C8 inhibitor is stopped (see **DRUG INTERACTIONS, Drug-Drug Interactions, In vivo studies**).

OVERDOSAGE

Isolated cases of overdose up to 3200 micrograms were reported. Mild, transient nausea was the only reported consequence. In the event of overdose, supportive measures must be taken as required.

Dialysis is unlikely to be effective because selexipag and its active metabolite are highly protein bound.

For management of a suspected drug overdose, contact your regional Poison Control Centre.

ACTION AND CLINICAL PHARMACOLOGY

Mechanism of Action

The vasculo-protective effects of prostacyclin (PGI₂) are mediated by the prostacyclin receptor (IP receptor). Decreased expression of IP receptors and decreased synthesis of prostacyclin contribute to the pathophysiology of PAH.

Selexipag is an oral, selective, IP receptor agonist, and is structurally and pharmacologically

distinct from prostacyclin and its analogues. Selexipag is hydrolysed by carboxylesterases to yield its active metabolite, which is approximately 37-fold more potent than selexipag. Selexipag and the active metabolite are high-affinity IP receptor agonists with a high selectivity for the IP receptor versus other prostanoid receptors (EP₁–EP₄, DP, FP, and TP).

Stimulation of the IP receptor by selexipag and the active metabolite leads to vasodilatory as well as anti-proliferative and anti-fibrotic effects. Selexipag improves haemodynamic variables and prevents cardiac and pulmonary remodelling in a rat model of PAH. In these PAH rats, pulmonary and peripheral vasodilation in response to selexipag correlate, indicating that peripheral vasodilation reflects pulmonary pharmacodynamic efficacy. Selexipag does not cause IP receptor desensitisation *in vitro* nor tachyphylaxis in a rat model.

PAH patients have variable degrees of IP receptor expression. Differences in the maintenance dose of selexipag between individuals may be related to differences in IP receptor expression levels.

Pharmacodynamics

Cardiac electrophysiology

In a thorough QT study in healthy subjects, repeated doses of 800 and 1600 micrograms of selexipag twice daily did not show an effect on cardiac repolarisation (QT_c interval) or conduction (PR and QRS intervals) and had a mild accelerating effect on heart rate.

Pulmonary haemodynamics

A Phase 2 double-blind, placebo-controlled clinical study assessed haemodynamic variables after 17 weeks of treatment in patients with PAH WHO FC II–III and concomitantly receiving ERAs and/or PDE-5 inhibitors. Patients titrating selexipag to an individually tolerated dose (200 micrograms twice daily increments up to 800 micrograms twice daily; N = 33) achieved a statistically significant mean reduction in pulmonary vascular resistance of 30.3% (95% confidence interval [CI] –44.7%, –12.2%; p = 0.0045) and an increase in cardiac index (mean treatment effect) of 0.48 L/min/m² (95% CI: 0.13, 0.83) compared to placebo (N = 10).

Pharmacokinetics

The pharmacokinetics of selexipag and its active metabolite have been studied primarily in healthy subjects. The pharmacokinetics of selexipag and the active metabolite, both after single- and multiple-dose administration, were dose-proportional up to a single dose of 800 micrograms and multiple doses of up to 1800 micrograms twice a day. After multiple-dose administration, steady-state conditions of selexipag and the active metabolite were reached within 3 days. No accumulation in plasma, either of parent compound or active metabolite, occurred after multiple-dose administration.

In healthy subjects, inter-subject variability in exposure (area under the curve over a dosing interval) at steady-state was 43% and 39% for selexipag and the active metabolite, respectively. Intra-subject variability in exposure was 24% and 19% for selexipag and the active metabolite, respectively.

Exposure to selexipag and the active metabolite at steady-state in PAH patients and healthy subjects was similar. The pharmacokinetics of selexipag and the active metabolite in PAH patients were not influenced by the severity of the disease and did not change with time.

Absorption

Selexipag is rapidly absorbed and is hydrolysed by carboxylesterases to its active metabolite.

Maximum observed plasma concentrations of selexipag and its active metabolite after oral administration are reached within 1–3 h and 3–4 h, respectively.

The absolute bioavailability of selexipag is approximately 49%.

In the presence of food, the exposure to selexipag after a single dose of 400 micrograms was increased by 10% in Caucasian subjects and decreased by 15% in Japanese subjects, whereas exposure to the active metabolite was decreased by 27% (Caucasian subjects) and 12% (Japanese subjects). More subjects reported adverse events after administration in the fasted than in the fed state.

Distribution

Selexipag and its active metabolite are highly bound to plasma proteins (approximately 99% in total and to the same extent to albumin and alpha1-acid glycoprotein).

The volume of distribution of selexipag at steady state is 11.7L.

Biotransformation

Selexipag is hydrolyzed to its active metabolite in the liver and in the intestine by carboxylesterases. Oxidative metabolism catalysed mainly by CYP2C8 and to a smaller extent by CYP3A4 leads to the formation of hydroxylated and dealkylated products. UGT1A3 and UGT2B7 are involved in the glucuronidation of the active metabolite. Except for the active metabolite, none of the circulating metabolites in human plasma exceed 3% of the total drug-related material. Both in healthy subjects and PAH patients, after oral administration, exposure at steady-state to the active metabolite is approximately 3- to 4-fold higher than to the parent compound.

Elimination

Elimination of selexipag is predominantly via metabolism with a mean terminal half-life of 0.8–2.5 h. The active metabolite has a half-life of 6.2–13.5 h. The total body clearance of selexipag is 17.9 L/h. Excretion in healthy subjects was complete 5 days after administration and occurred primarily via faeces (accounting for 93% of the administered dose) compared to 12% in urine.

Special Populations and Conditions

No clinically relevant effects of sex, race, age, or body weight on the pharmacokinetics of selexipag and its active metabolite have been observed in healthy subjects or PAH patients.

Renal impairment

A 1.4- to 1.7-fold increase in exposure (maximum plasma concentration and area under the plasma concentration-time curve) to selexipag and its active metabolite was observed in subjects with severe renal impairment (estimate glomerular filtration rate < 30 mL/min/1.73 m²).

Hepatic impairment

In subjects with mild (Child-Pugh class A) or moderate (Child-Pugh class B) hepatic impairment, after a single dose administration of 400 micrograms of selexipag, exposure to selexipag was 2- and 4-fold higher, respectively, when compared to healthy subjects. Exposure to the active metabolite remained almost unchanged in subjects with mild hepatic impairment and was doubled in subjects with moderate hepatic impairment. Only two subjects with severe (Child-Pugh class C) hepatic impairment were dosed with selexipag. Exposure to selexipag and its active metabolite in these two subjects was similar to that in subjects with moderate (Child-Pugh class B) hepatic impairment.

Based on pharmacokinetic modeling of data from a study in subjects with hepatic impairment, exposure to the active metabolite at steady state in subjects with moderate hepatic impairment (Child-Pugh class B) after a once daily regimen is expected to be similar to that in healthy subjects receiving a twice daily regimen. The exposure to selexipag at steady state in subjects with moderate hepatic impairment during a once daily regimen is predicted to be approximately 2-fold that seen in healthy subjects receiving a twice daily regimen.

STORAGE AND STABILITY

UPTRAVI[®] (selexipag) should be stored at room temperature (15 to 30°C).

DOSAGE FORMS, COMPOSITION AND PACKAGING

UPTRAVI[®] is available in the following 8 strengths of selexipag:

200 mcg	Round, light-yellow, film-coated tablets with “2” debossed on one side.
400 mcg	Round, red, film-coated tablets with “4” debossed on one side
600 mcg	Round, light-violet, film-coated tablets with “6” debossed on one side.
800 mcg	Round, green, film-coated tablets with “8” debossed on one side
1000 mcg	Round, orange, film-coated tablets with “10” debossed on one side.
1200 mcg	Round, dark-violet, film-coated tablets with “12” debossed on one side.
1400 mcg	Round, dark-yellow, film-coated tablets with “14” debossed on one side.
1600 mcg	Round, brown, film-coated tablets with “16” debossed on one side

The non-medicinal ingredients are:

200 mcg	carnauba wax, corn starch, D-mannitol, hydroxypropyl cellulose, hypromellose, iron oxide yellow (E172), low substituted hydroxypropyl cellulose, magnesium stearate, propylene glycol, titanium dioxide (E171)
400 mcg	carnauba wax, corn starch, D-mannitol, hydroxypropyl cellulose, hypromellose, iron oxide red (E172), low substituted hydroxypropyl cellulose, magnesium

	stearate, propylene glycol, titanium dioxide (E171)
600 mcg	carnauba wax, corn starch, D-mannitol, hydroxypropyl cellulose, hypromellose, iron oxide black (E172), iron oxide red (E172), low substituted hydroxypropyl cellulose, magnesium stearate, propylene glycol, titanium dioxide (E171)
800 mcg	carnauba wax, corn starch, D-mannitol, hydroxypropyl cellulose, hypromellose, iron oxide black (E172), iron oxide yellow (E172), low substituted hydroxypropyl cellulose, magnesium stearate, propylene glycol, titanium dioxide (E171)
1000 mcg	carnauba wax, corn starch, D-mannitol, hydroxypropyl cellulose, hypromellose, iron oxide red (E172), iron oxide yellow (E172), low substituted hydroxypropyl cellulose, magnesium stearate, propylene glycol, titanium dioxide (E171)
1200 mcg	carnauba wax, corn starch, D-mannitol, hydroxypropyl cellulose, hypromellose, iron oxide black (E172), iron oxide red (E172), low substituted hydroxypropyl cellulose, magnesium stearate, propylene glycol, titanium dioxide (E171)
1400 mcg	carnauba wax, corn starch, D-mannitol, hydroxypropyl cellulose, hypromellose, iron oxide yellow (E172), low substituted hydroxypropyl cellulose, magnesium stearate, propylene glycol, titanium dioxide (E171)
1600 mcg	carnauba wax, corn starch, D-mannitol, hydroxypropyl cellulose, hypromellose, iron oxide black (E172), iron oxide red (E172), iron oxide yellow (E172), low substituted hydroxypropyl cellulose, magnesium stearate, propylene glycol, titanium dioxide (E171)

Availability

UPTRAVI® 200, 400, 600, 800, 1000, 1200, 1400, and 1600 microgram film-coated tablets
Polyamide / aluminium / high-density polyethylene / polyethylene with an embedded desiccant agent / high-density polyethylene blister sealed with an aluminium foil (Alu/Alu blister with desiccant) in cartons of 60 film-coated tablets.

PART II: SCIENTIFIC INFORMATION

PHARMACEUTICAL INFORMATION

Drug Substance

Proper name:	Selexipag
Chemical names:	2-{4-[(5,6-diphenylpyrazin-2-yl)(isopropyl)amino]butoxy}-N-(methylsulfonyl)acetamide 2-[4-[N-(5,6-diphenylpyrazin-2-yl)-N-isopropylamino]butyloxy]-N-(methylsulfonyl)acetamide
Molecular formula:	C ₂₆ H ₃₂ N ₄ O ₄ S
Molecular mass:	496.62

Structural formula:

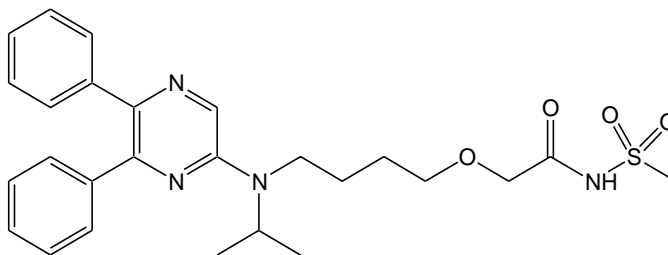

Physicochemical properties:

Selexipag is a pale yellow crystalline powder that is practically insoluble in water. In the solid state, selexipag is very stable, is not hygroscopic, and is not light sensitive.

CLINICAL TRIALS

Study demographics and trial design

Efficacy in patients with PAH

The effect of selexipag on progression of PAH was demonstrated in a multi-centre, long-term (maximum duration of exposure approximately 4.2 years), double-blind, placebo-controlled, parallel-group, event-driven Phase 3 study in 1156 patients with symptomatic (WHO FC I–IV) PAH. Patients were randomised to either placebo (N = 582) or selexipag (N = 574) twice a day. The dose was increased at weekly intervals by increments of 200 micrograms given twice a day to determine the individualised maintenance dose (200–1600 micrograms twice a day).

The primary study endpoint was the time to first occurrence of a morbidity or mortality event up to end of treatment, defined as a composite of death (all causes); or hospitalisation for PAH; or progression of PAH resulting in need for lung transplantation or balloon atrial septostomy; or initiation of parenteral prostanoid therapy or chronic oxygen therapy; or other disease-progression events (patients in WHO FC II or III at baseline) confirmed by a decrease in 6-minute walk distance (6MWD) from baseline ($\geq 15\%$) and worsening of WHO FC or (patients in WHO FC III or IV at baseline) confirmed by a decrease in 6MWD from baseline ($\geq 15\%$) and need for additional PAH-specific therapy.

All events were confirmed by an independent adjudication committee, blinded to treatment allocation.

The mean age was 48.1 years (range 18–80 years of age), with the majority of subjects being Caucasian (65.0%) and female (79.8%). Approximately 1%, 46%, 53% and 1% of patients were in WHO FC I, II, III and IV, respectively, at baseline.

Idiopathic or heritable PAH was the most common aetiology in the study population (58%) followed by PAH due to connective tissue disorders (29%), PAH associated with congenital heart disease with repaired shunts (10%), and PAH associated with other aetiologies (drugs and toxins [2%] and HIV [1%]).

At baseline, the majority of enrolled patients (80%) were being treated with a stable dose of a specific therapy for PAH, either an ERA (15%) or a PDE-5 inhibitor (32%) or both an ERA and a PDE-5 inhibitor (33%).

The overall median double-blind treatment duration was 63.7 weeks for the placebo group and 70.7 weeks for the group on selexipag.

Treatment with selexipag 200–1600 micrograms twice a day resulted in a 40% reduction (hazard ratio [HR] 0.60; 99% CI: 0.46, 0.78; one-sided log-rank p value < 0.0001) of the occurrence of morbidity or mortality events up to 7 days after last dose compared to placebo [Figure 1]. The beneficial effect of selexipag was primarily attributable to a reduction in hospitalisation for PAH

and a reduction in other disease-progression events [Table 3].

Figure 1 Kaplan-Meier estimates of the first morbidity-mortality event in GRIPHON

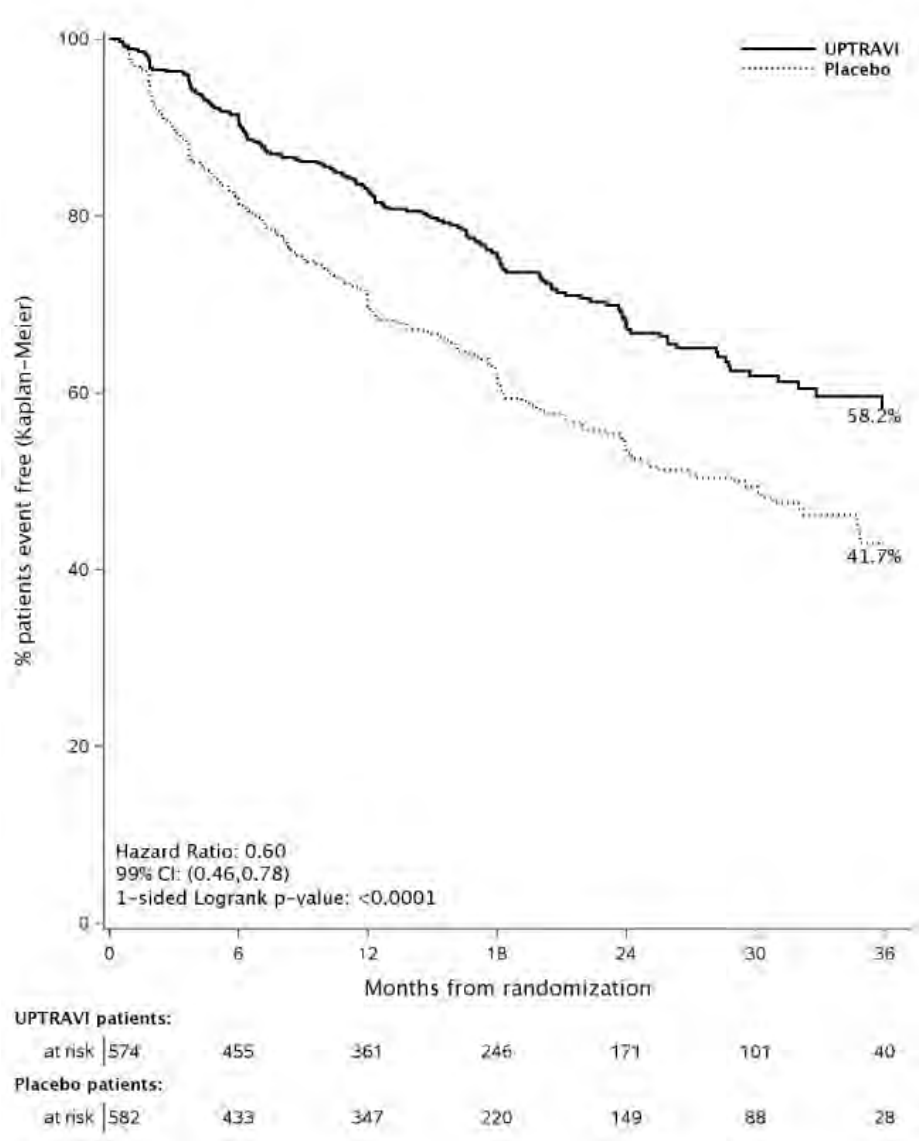

Table 3 Type of first event as component of primary endpoint

	Selexipag N = 574 n (%)	Placebo N = 582 n (%)
Patients with a primary endpoint event	155 (27.0)	242 (41.6)
Component as first event		
Hospitalization for PAH	78 (13.6)	109 (18.7)
Disease progression	38 (6.6)	100 (17.2)
Death	28 (4.9)	18 (3.1)
i.v./s.c. prostanoid or chronic oxygen therapy	10 (1.7)	13 (2.2)
Need for lung transplantation or atrial septostomy	1 (0.2)	2 (0.3)

i.v. = intravenous; PAH = pulmonary arterial hypertension; s.c. = subcutaneous.

The observed effect of selexipag versus placebo on the primary endpoint was independent of the achieved individualized maintenance dose (IMD) [Figure 2]:

IMD 200–400 mcg twice daily (23.2% of patients): HR 0.60 (95% CI: 0.41, 0.88, one-sided log-rank $p = 0.0038$)

IMD 600–1000 mcg twice daily (31.4% of patients): HR 0.53 (95% CI: 0.38, 0.72, one-sided log-rank $p < 0.0001$)

IMD 1200–1600 mcg twice daily (42.9% of patients): HR 0.64 (95% CI: 0.49, 0.82, one-sided log-rank $p = 0.0002$).

Figure 2 Kaplan-Meier estimates of the first morbidity-mortality event in GRIPHON by individual maintenance dose group

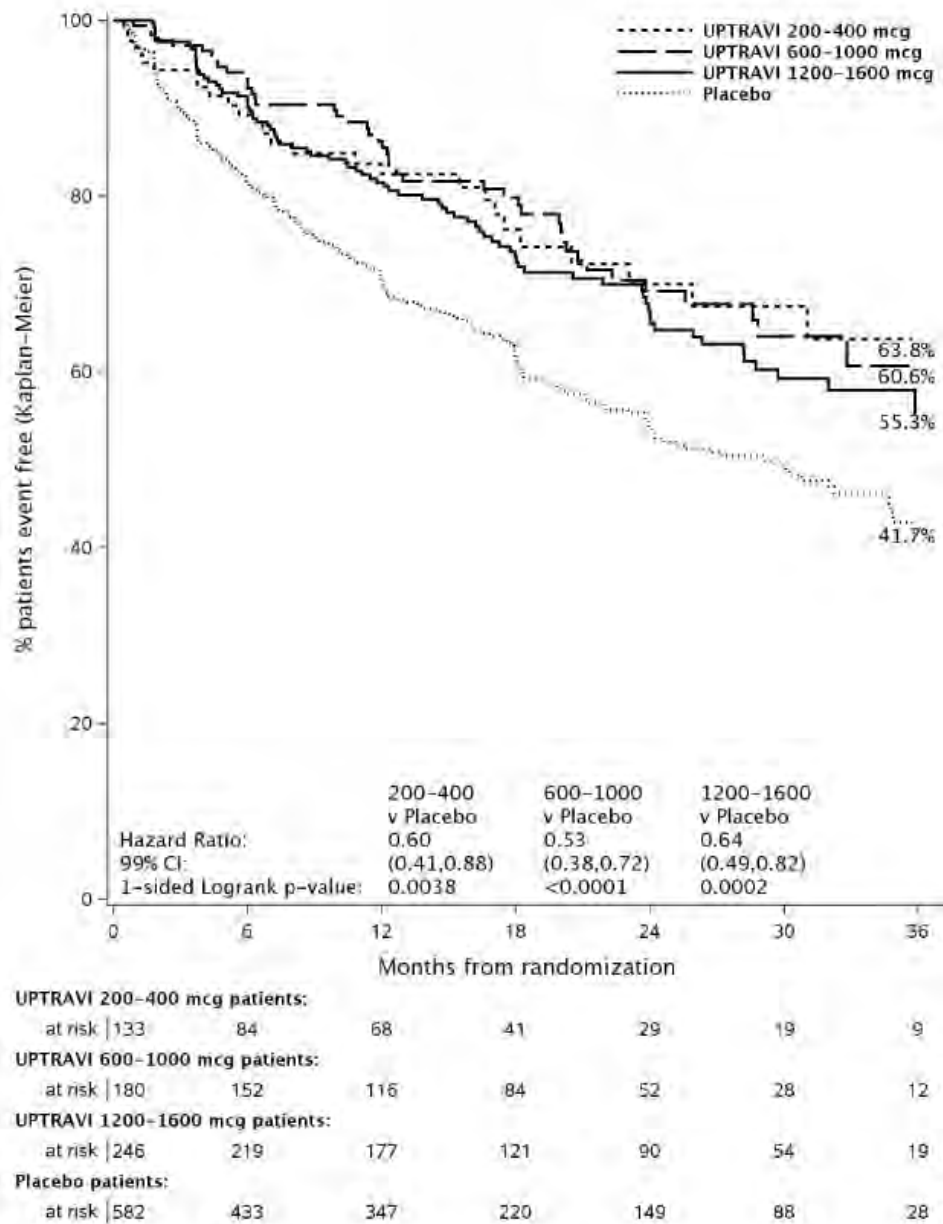

Subgroup analyses were performed across subgroups of age, sex, race, etiology, geographical region, WHO FC, and by monotherapy or in combination with ERA, PDE-5 inhibitors or triple combination with both an ERA and a PDE-5 inhibitor [Figure 3].

Figure 3 Subgroup analyses of the primary endpoint in the GRIPHON study

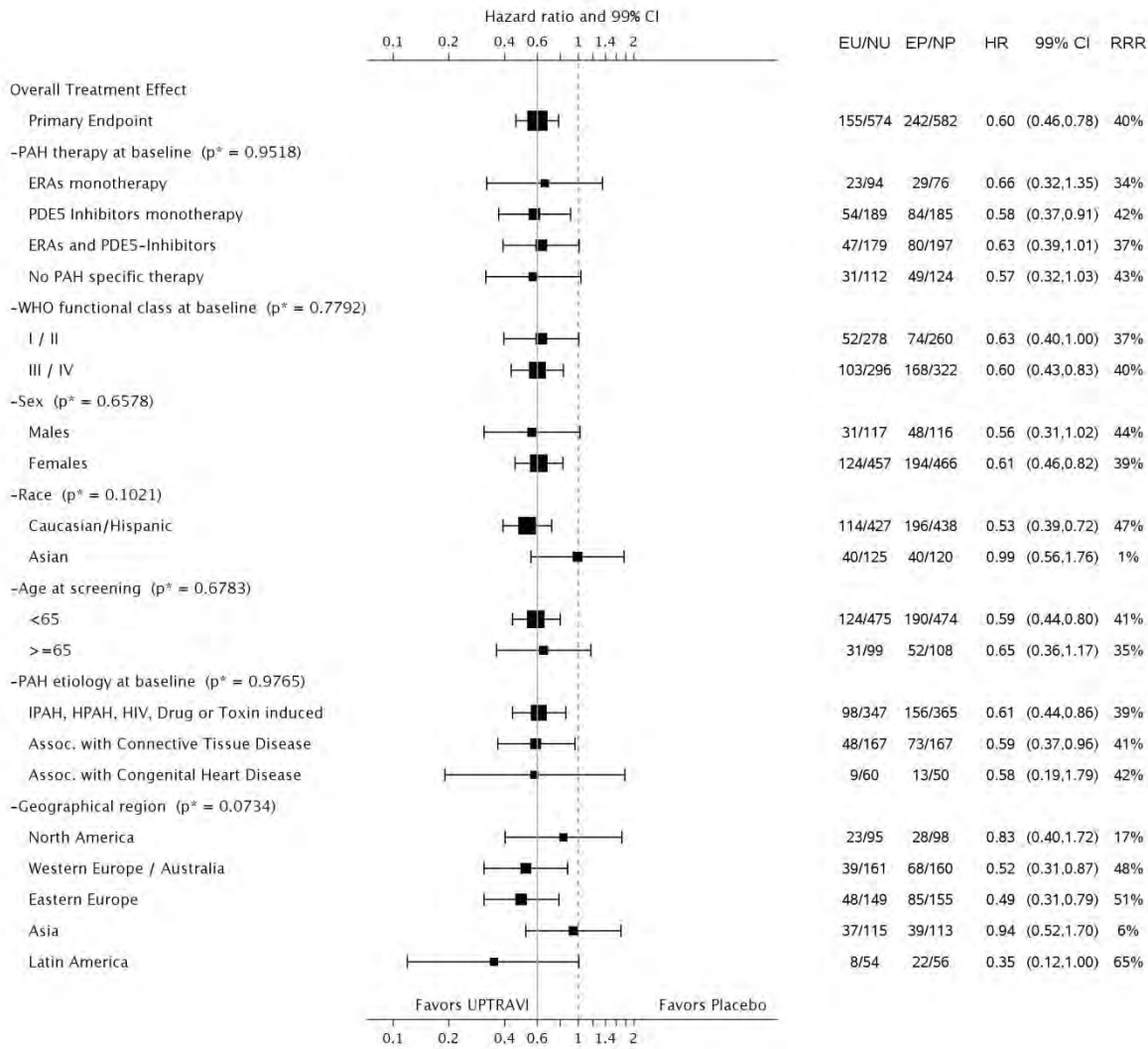

CI = confidence interval; EP = number of placebo patients with events; EU = number of UPTRAVI® patients with events; HR = hazard ratio; NP = number of patients randomized to placebo; NU = number of patients randomized to UPTRAVI®; RRR = relative risk reduction.

The size of the square represents the number of patients in the subgroup.

Time to PAH-related death or hospitalization for PAH was assessed as a secondary endpoint. The risk of an event for this endpoint was reduced by 30% in patients receiving UPTRAVI® compared to placebo (HR 0.70, 99% CI: 0.50, 0.98; one-sided log-rank p = 0.0031) [Figure 4].

Figure 4 Kaplan-Meier estimates of the occurrence of death due to PAH or first hospitalization for PAH in GRIPHON

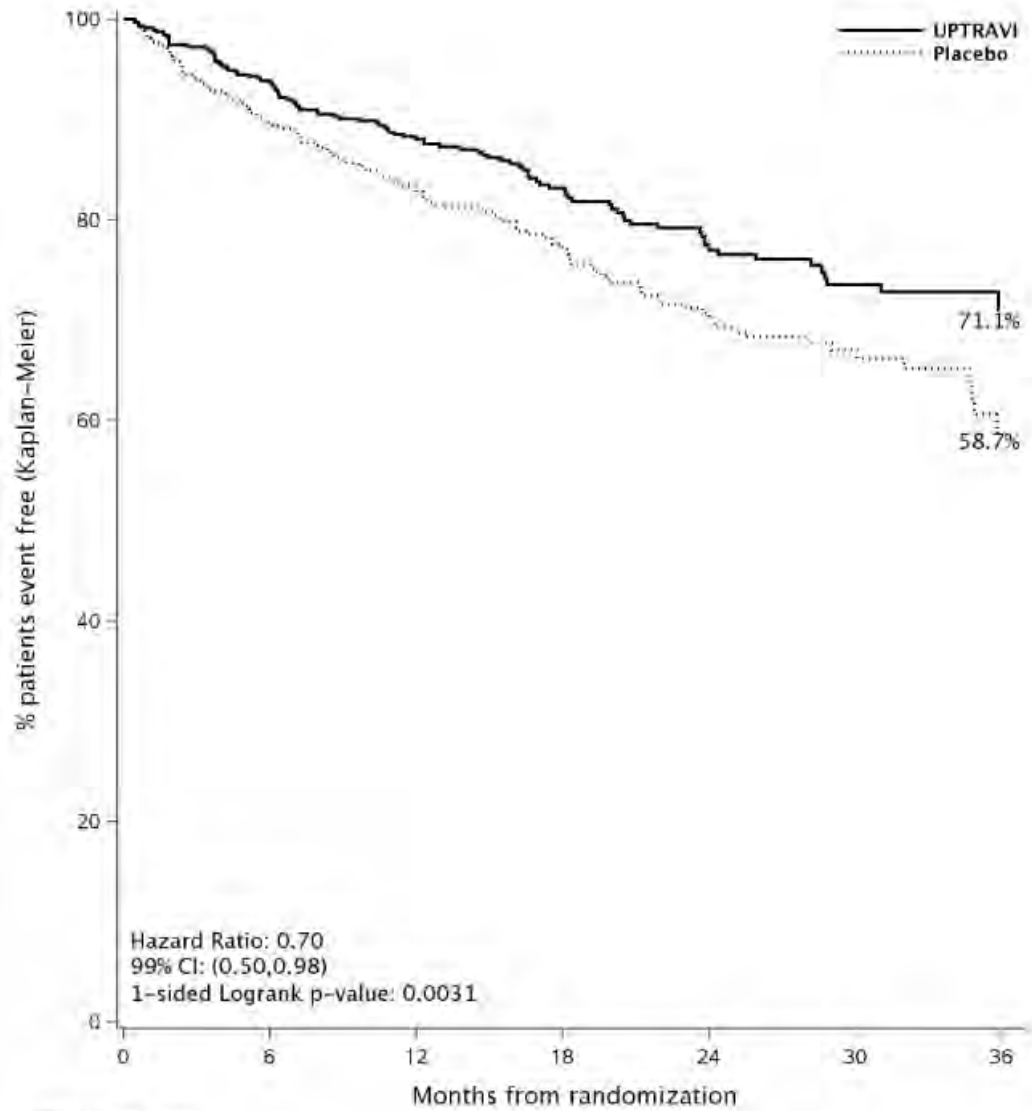

	0	6	12	18	24	30	36
UPTRAVI patients:							
at risk	574	457	364	250	172	102	40
Placebo patients:							
at risk	582	437	351	227	152	89	28

The number of patients who experienced as a first event, death due to PAH or hospitalization for PAH up to end of treatment was 102 (17.8%) in the selexipag group, and 137 (23.5%) in the placebo group. Death due to PAH as a component of the endpoint was observed in 16 (2.8%) patients on selexipag and 14 (2.4%) on placebo. Hospitalization for PAH was observed in 86 (15%) of patients on selexipag and 123 (21.1%) of patients on placebo. UPTRAVI[®] reduced the risk of hospitalization for PAH as first outcome event compared to placebo (HR 0.67, 99% CI: 0.46, 0.98); one-sided log-rank $p = 0.04$).

The total number of deaths of all causes up to study closure was 100 (17.4%) for the UPTRAVI[®] group and 105 (18.0%) for the placebo group (HR 0.97, 99% CI: 0.68, 1.39) [Figure 5].

Figure 5 Kaplan-Meier estimates of the occurrence of death up to study closure

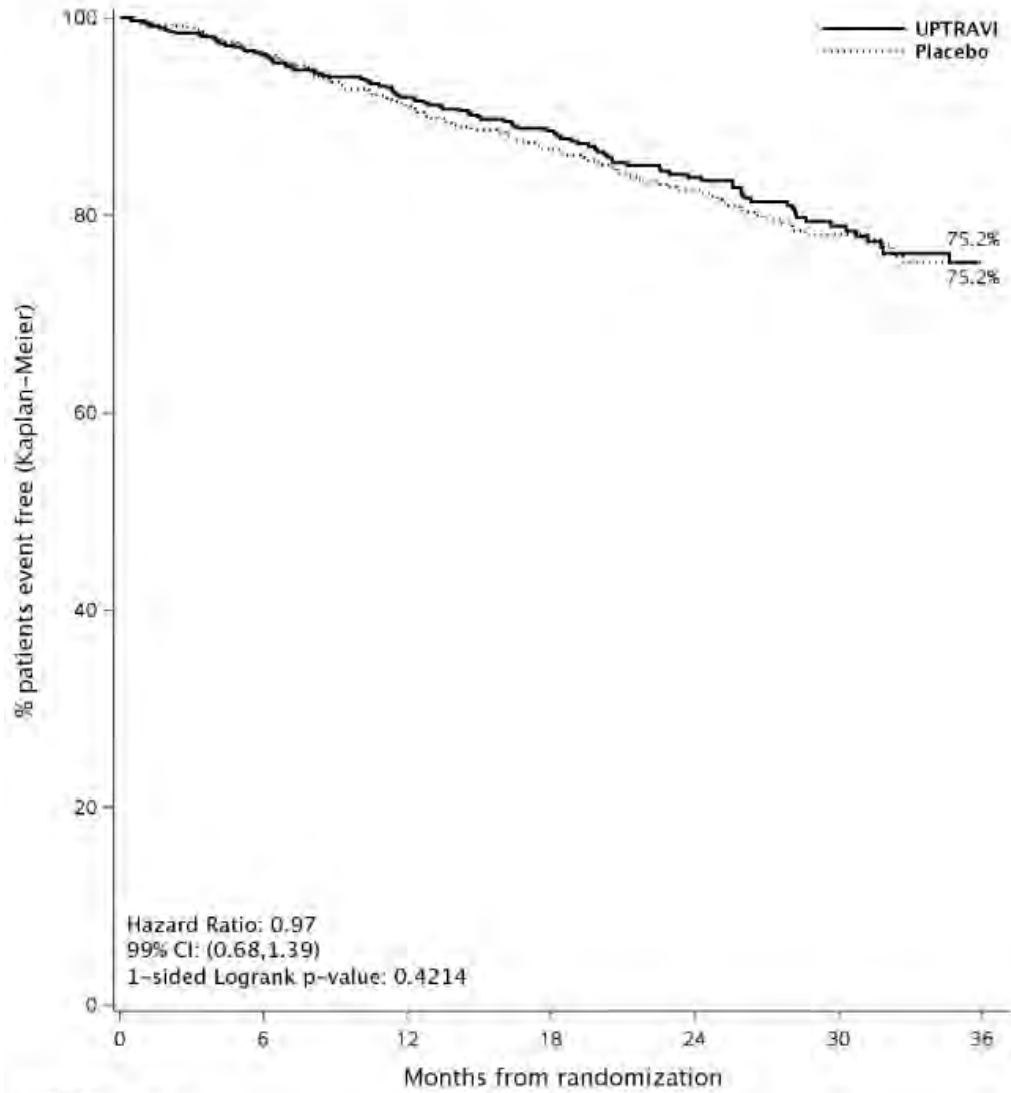

	0	6	12	18	24	30	36
UPTRAVI patients:							
at risk	574	543	473	350	257	161	64
Placebo patients:							
at risk	582	546	491	356	273	168	70

The number of deaths due to PAH up to study closure was 70 (12.2%) for the UPTRAVI® group and 83 (14.3%) for the placebo group [Figure 6].

Figure 6 Kaplan-Meier estimates of the occurrence of death due to PAH up to study closure

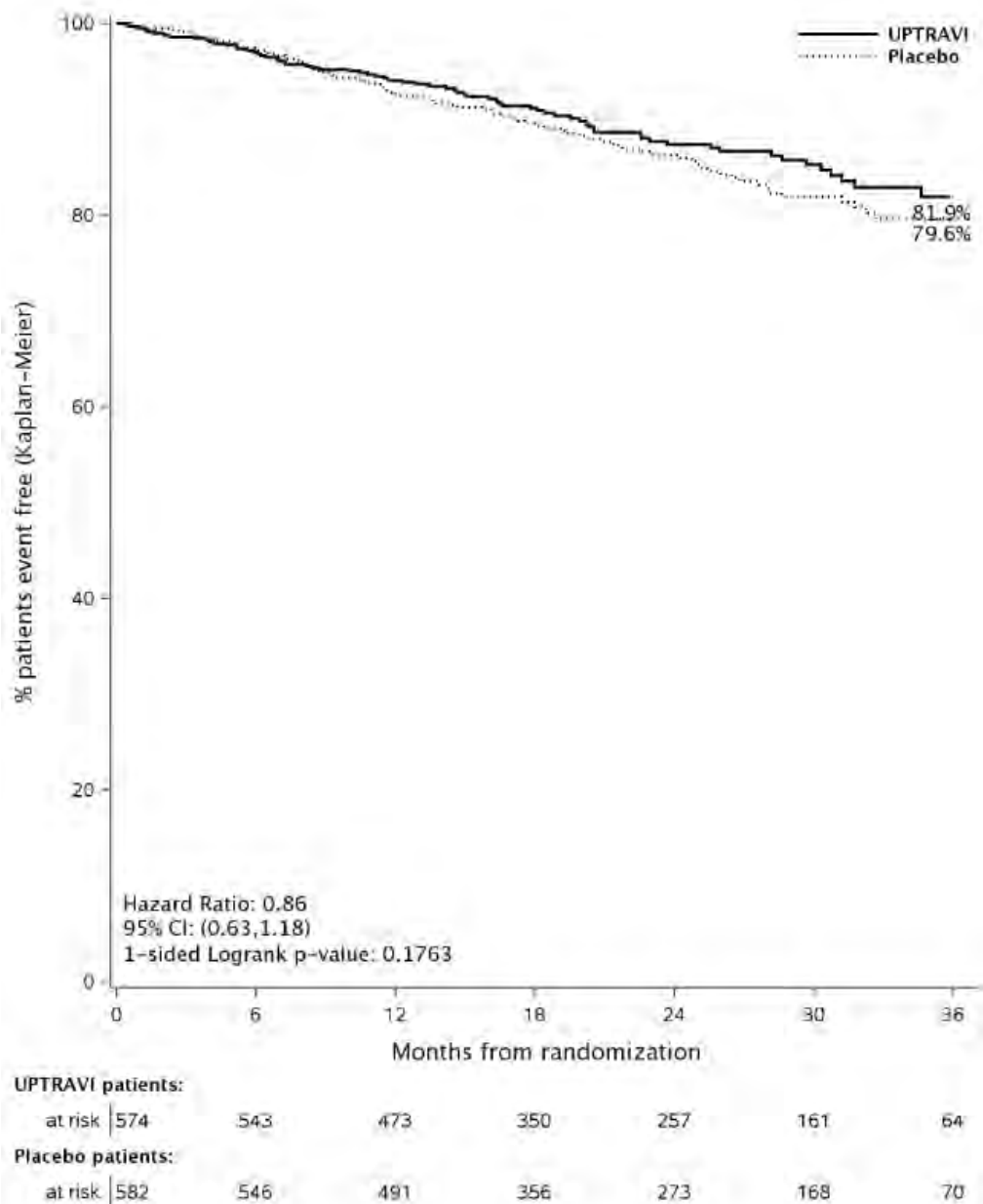

Symptomatic endpoint

Exercise capacity was evaluated as a secondary endpoint. Treatment with UPTRAVI® resulted in a placebo-corrected median increase in 6MWD measured at trough (i.e., approximately 12 hours

post-dose) of 12 meters at Week 26 (99% CI: 1, 24 meters, one-sided p value = 0.0027). In patients without concurrent PAH-specific therapy, the treatment effect measured at trough was 34 meters (99% CI: 10, 63 meters).

DETAILED PHARMACOLOGY

Pharmacodynamics

Selexipag and its active metabolite are potent and selective non-prostanoid agonists for the human prostacyclin (PGI₂) receptor (IP receptor) *in vitro*. The active metabolite is up to 37-fold more potent than selexipag in cellular assays, is present at 3–4 fold higher plasma concentration than selexipag, and is the major contributor to pharmacological effects.

Pharmacokinetics

The pharmacokinetic profile of selexipag is characterized by rapid absorption with a t_{max} of approximately 1 h, and $t_{1/2}$ of approximately 0.8–2.5 h. The active metabolite is formed rapidly and has an apparent elimination half-life of approximately 6.2–13.5 h. In healthy subjects, steady-state conditions of selexipag and its active metabolite are achieved within 3 days and there is no accumulation. The pharmacokinetics of selexipag and its active metabolite are largely dose-proportional. Exposure in PAH patients is comparable to that in healthy subjects.

Selexipag is eliminated after metabolism, primarily via enzymatic hydrolysis by CES1 in the liver to the active metabolite. Additional metabolic steps are catalyzed by CYP3A4, CYP2C8 and CYP1A2, and UGT1A3 and UGT2B7. Drug elimination is mainly fecal, with renal excretion accounting for only approximately 12% of the administered dose.

An acylglucuronide, a potentially reactive metabolite, is formed during the metabolism of selexipag. Given the low exposure to this metabolite in humans, safety concerns are unlikely.

The pharmacokinetics of selexipag and its active metabolite are not relevantly affected by intrinsic factors (age, sex, race), PAH disease severity, mild or moderate hepatic impairment or severe renal impairment, or by food. Selexipag and ACT-333679 are not inhibitors or inducers of CYP enzymes at clinically relevant concentrations and do not interact with P-gp, OATP, or BSEP at such concentrations.

TOXICOLOGY

In vitro, the active metabolite ACT-333679, but not selexipag, was a potent IP receptor agonist in the rat and dog. ACT-333679 was selective for the IP receptor in the rat, and equally potent at IP and EP₄ receptor of dogs in cellular assays.

Repeated Dose Toxicity

In the repeated-dose toxicity studies in animals, selexipag treatment resulted in effects related to exaggerated pharmacology. In rats and mice, the clinical signs were consistent with peripheral vasodilation. Flush of the limbs and/or pinna and/or flaccidity were noted in mice at ≥ 125 mg/kg/day and in rats at ≥ 6 mg/kg/day. The incidence and/or severity of clinical signs decreased

with duration of repeated dosing. In dogs less than 1 year of age, intestinal intussusception occurred at doses ≥ 4 mg/kg, associated with clinical signs, including anal prolapse, bloody diarrhea, and body weight loss, necessitating euthanasia of affected animals. Intussusception did not occur in dogs at ≤ 2 mg/kg, at which systemic exposure (AUC) to selexipag was 180 times that in humans at the maximum recommended human dose (MRHD) of 1600 micrograms BID.

Dose related minimal to mild hepatocellular hypertrophy was observed in rats and mice. Minimal hyperplasia of thyroid follicular cells (females), minimal to mild adrenal cortical hypertrophy, increased incidence and/or severity of minimal to mild diffuse hyperplasia of the acinar cells in the mammary gland (females), and minimal hypertrophy of the acinar cells in the submandibular salivary gland (females) were noted in the rat. The NOAEL was 100 mg/kg/day in the mouse and 6 mg/kg/day in the rat. In mice, exposure at NOAEL was 130- (selexipag) and 40-fold (ACT-333679) the exposure at MRHD, whereas in rats, exposure at NOAEL was 3- (selexipag) and 20-fold (ACT-333679) the exposure at MRHD, and exposure to selexipag was approximately similar to and 30 times higher than that at the MRHD in rats and mice, respectively. Systemic exposure to ACT-333679 was 50 and 130 times higher than that at the MRHD in rats and mice, respectively. Increased bone ossification and bone marrow hypercellularity were noted in dogs at all dose levels. Similar effects were not seen in rats and mice and the effect is considered related to the action of ACT-333679 on EP4 receptors. As human EP4 receptors are not activated by selexipag or its active metabolite, this effect is most likely species-specific and not relevant to humans.

Genotoxicity

Selexipag and the active metabolite are on the basis of the weight of evidence not considered genotoxic.

Carcinogenicity

In the 2-year carcinogenicity studies, selexipag caused an increased incidence of thyroid adenomas and carcinoma in mice at 250 and 500 mg/kg/day and benign Leydig cell tumors in rats at 100 mg/kg/day. The mechanisms are rodent-specific. The increase in tumor incidence was observed at exposures that were more than 25-fold above human exposure at the MHRD and are, therefore, not relevant for humans.

Reproductive toxicity

There were no effects on fertility in male rats, while there was a tendency towards prolongation of the estrus cycle and an increase in days until copulation in females at 60 mg/kg, but no effects on fertility and early embryonic development. At a NOAEL of 20 mg/kg/day, selexipag exposure was 6 times higher than that at the MRHD and ACT-333679 exposure 31 times higher than at the MRHD.

In the embryo-fetal development studies in rats and rabbits, the only embryo-fetal effect was reduced fetal weight secondary to reduced maternal weight in rats at 20 mg/kg. There were no effects on ossification, evidence of malformations or other treatment-related abnormalities at any dose level (up to 20 mg/kg in rat and 30 mg/kg in rabbit). At the rat NOAEL (6 mg/kg) systemic exposure to selexipag and ACT-333796 was similar to and >10 times higher than that at the MHRD, respectively. At the rabbit NOAEL of 30 mg/kg, systemic exposure to selexipag and

ACT-333796 was >10 and >50 times higher than that at the MHRD, respectively.

In a peri- and post-natal development study, oral administration of selexipag to rats at doses up to 20 mg/kg from day 6 of gestation until day 20 of lactation had no effect on peri and post-natal development of the pups.

In a juvenile (1 month old at study start) dog study, oral selexipag administration at 1, 3, and 6 mg/kg resulted in the death of 2 dogs due to intestinal intussusception at 6 mg/kg. The high dose was lowered to 4 mg/kg and there were no further deaths during the 39 week duration of the study. Dermatitis, as well as decreases in thymic weight with no histological correlates, were considered stress responses. Reduced body weight gain was noted throughout dosing in females. No heat was noted in females given 3 and 4/6 mg/kg/day in the latter part of the study and correlated with delayed sexual maturation in the ovaries, which may in part be related to reduced body weight gain. Similar to treatment of older dogs, increased bone marrow cellularity and bone ossification were noted at all doses (≥ 1 mg/kg) after 39 weeks of dosing. At Week 39 necropsy, delayed closure of the femoral and/or tibial epiphyseal growth plates was observed at all doses, but there was no effect on bone length. Findings in juvenile animals were generally similar to those in young animals (described above) and a NOAEL was not identified.

Phototoxicity

Selexipag and its active metabolite were phototoxic *in vitro*. A dedicated clinical study did not indicate a phototoxic potential of selexipag in humans.

REFERENCES

Sitbon O, Channick R, Chin KM, Frey A, Gaine S, Galiè N et al. Selexipag for the treatment of pulmonary arterial hypertension. N Engl J Med. 2015;373:2522-33.

**READ THIS FOR SAFE AND EFFECTIVE USE OF YOUR MEDICINE
PATIENT MEDICATION INFORMATION**

**Pr UPTRAVI®
Selexipag (film-coated) tablets**

Read this carefully before you start taking **UPTRAVI®** and each time you get a refill. This leaflet is a summary and will not tell you everything about this drug. Talk to your healthcare professional about your medical condition and treatment and ask if there is any new information about **UPTRAVI®**. Tell your doctor if you experience side effects, as your doctor may recommend that you change your **UPTRAVI®** dose. Tell your doctor if you are taking other medications as your doctor may recommend that you take **UPTRAVI®** only once daily.

What is UPTRAVI® used for?

UPTRAVI® is used for the long-term treatment of pulmonary arterial hypertension (PAH) in adults. It can be used on its own or with other medicines for PAH. PAH is high blood pressure in the blood vessels that carry blood from the heart to the lungs (the pulmonary arteries).

How does UPTRAVI® work?

UPTRAVI® widens the arteries that carry blood from the heart to the lung and reduces their hardening. This makes it easier for the heart to pump blood through the pulmonary arteries.

What are the ingredients in UPTRAVI®?

Medicinal ingredients: Selexipag.

Non-medicinal ingredients:

Strength	Non-medicinal ingredients
200 mcg	carnauba wax, corn starch, D-mannitol, hydroxypropyl cellulose, hypromellose, iron oxide yellow (E172), low substituted hydroxypropyl cellulose, magnesium stearate, propylene glycol, titanium dioxide (E171)
400 mcg	carnauba wax, corn starch, D-mannitol, hydroxypropyl cellulose, hypromellose, iron oxide red (E172), low substituted hydroxypropyl cellulose, magnesium stearate, propylene glycol, titanium dioxide (E171)
600 mcg	carnauba wax, corn starch, D-mannitol, hydroxypropyl cellulose, hypromellose, iron oxide black (E172), iron oxide red (E172), low substituted hydroxypropyl cellulose, magnesium stearate, propylene glycol, titanium dioxide (E171)
800 mcg	carnauba wax, corn starch, D-mannitol, hydroxypropyl cellulose, hypromellose, iron oxide black (E172), iron oxide yellow (E172), low substituted hydroxypropyl cellulose, magnesium stearate, propylene glycol, titanium dioxide (E171)
1000 mcg	carnauba wax, corn starch, D-mannitol, hydroxypropyl cellulose, hypromellose, iron oxide red (E172), iron oxide yellow (E172), low substituted hydroxypropyl cellulose, magnesium stearate, propylene glycol, titanium dioxide (E171)
1200 mcg	carnauba wax, corn starch, D-mannitol, hydroxypropyl cellulose, hypromellose, iron oxide black (E172), iron oxide red (E172), low substituted hydroxypropyl cellulose, magnesium stearate, propylene glycol, titanium dioxide (E171)

1400 mcg	carnauba wax, corn starch, D-mannitol, hydroxypropyl cellulose, hypromellose, iron oxide yellow (E172), low substituted hydroxypropyl cellulose, magnesium stearate, propylene glycol, titanium dioxide (E171)
1600 mcg	carnauba wax, corn starch, D-mannitol, hydroxypropyl cellulose, hypromellose, iron oxide black (E172), iron oxide red (E172), iron oxide yellow (E172), low substituted hydroxypropyl cellulose, magnesium stearate, propylene glycol, titanium dioxide (E171)

UPTRAVI® comes in the following dosage forms:

Strength	Description of the tablets
200 mcg	film-coated tablets (round, light-yellow, film-coated tablets with “2” marked on one side)
400 mcg	film-coated tablets (round, red, film-coated tablets with “4” marked on one side)
600 mcg	film-coated tablets (round, light-violet, film-coated tablets with “6” marked on one side)
800 mcg	film-coated tablets (round, green, film-coated tablets with “8” marked on one side)
1000 mcg	film-coated tablets (round, orange, film-coated tablets with “10” marked on one side)
1200 mcg	film-coated tablets (round, dark-violet, film-coated tablets with “12” marked on one side)
1400 mcg	film-coated tablets (round, dark-yellow, film-coated tablets with “14” marked on one side)
1600 mcg	film-coated tablets (round, brown, film-coated tablets with “16” marked on one side)

Do not use UPTRAVI® if:

If you are allergic to selexipag or any of the other ingredients of this medicine.

If you are being treated with strong inhibitors of CYP2C8 (e.g., gemfibrozil).

To help avoid side effects and ensure proper use, talk to your healthcare professional before you take UPTRAVI®. Talk about any health conditions or problems you may have, including if you:

- have low blood pressure
- have liver problems
- have kidney problems or are on dialysis
- have narrowing of the pulmonary veins, a condition called pulmonary veno-occlusive disease or PVOD
- have overactive thyroid gland
- are pregnant or plan to become pregnant
- are breastfeeding or plan to breastfeed
- have any other medical conditions

Driving and using machines

UPTRAVI® can cause side effects such as headaches and low blood pressure. Before driving or using machines, make sure you know how you feel while taking UPTRAVI®.

Tell your healthcare professional about all the medicines you take, including any drugs, vitamins, minerals, natural supplements or alternative medicines.

Taking other medicines may affect how UPTRAVI® works.

Talk to your PAH doctor or nurse if you are taking any of the following medicines:

- Gemfibrozil (used to lower the level of fats [lipids] in the blood)
- Valproic acid (used to treat epilepsy)
- Rifampicin, rifapentine (antibiotic used to treat infections)
- Fluconazole (antifungal used to treat infection by fungi)
- Clopidogrel (medicine used to inhibit blood clots)
- Deferasirox (medicine used to remove excess iron from the body)
- Teriflunomide (medicine used to treat relapsing-remitting multiple sclerosis)

Tell your doctor if you are taking, have recently taken, or might take any other medicines.

How to take UPTRAVI®:

- UPTRAVI® should only be prescribed by a doctor experienced in the treatment of pulmonary arterial hypertension.
- Always take UPTRAVI® exactly as your doctor has told you.
- Check with your doctor if you are not sure or have any questions.
- Take UPTRAVI® in the morning and in the evening, either with or without meals.
- You might tolerate the medicine better when you take it with meals.
- Swallow the tablets whole with a glass of water.
- Do not split, crush or chew the tablets.

Finding the right dose for you

- At the start of treatment, you will take the lowest dose. This is one 200 microgram tablet **in the morning and another tablet in the evening.**
- As instructed by your doctor, you will gradually increase your dose. This is called titration. It lets your body adjust to the new medicine.
- The goal of titration is to reach the most appropriate dose to treat you; this will be the highest dose you can tolerate.
- During titration, you may experience side effects such as headache, jaw pain, aching joints, muscle pain or a general feeling of being in pain, diarrhoea, feeling sick to your stomach or throwing up, stomach ache or reddening of the face.
- Tell your doctor if you experience side effects, as your doctor may recommend that you change your UPTRAVI® dose.
- Tell your doctor if you are taking other medications as your doctor may recommend that you take UPTRAVI® only once daily.
- If any of these side effects are difficult for you to tolerate, talk to your doctor about how to manage or treat them. There are treatments available that can help relieve the side

effects. **Do not stop taking UPTRAVI® unless your doctor tells you to.**

Usual dose:

The highest dose that you can tolerate during titration will become your maintenance dose. Your maintenance dose is the dose you should continue to take on a regular basis, in the morning and in the evening.

Every patient with PAH is different. Not everyone will end up on the same maintenance dose. Your maintenance dose will be between 200 micrograms and 1600 micrograms in the morning and in the evening. What is important is that you reach the dose that is most appropriate to treat you.

After taking the same dose for a long time, you may experience side effects that you cannot tolerate or that have an effect on your normal daily activities. If this happens, contact your doctor. Your doctor may adjust your maintenance dose as needed.

Overdose:

If you think you have taken too much UPTRAVI®, contact your healthcare professional, hospital emergency department or regional Poison Control Centre immediately, even if there are no symptoms.

Missed Dose:

- If you forget to take UPTRAVI®, take a dose as soon as you remember. Continue to take your next dose at the usual time.
- If it is nearly time for your next dose (within 6 hours before you would normally take it), skip the missed dose. Continue to take your next dose at the usual time.
- Do not take a double dose to make up for a forgotten tablet.

If you stop taking UPTRAVI®

- Keep taking UPTRAVI® unless your doctor tells you to stop.
- **Contact your doctor right away if you miss doses for more than 3 days in a row.**
- Your doctor may decide to restart your treatment at a lower dose to avoid side effects. Your dose may be gradually increased to your previous maintenance dose.

What are possible side effects from using UPTRAVI®?

These are not all the possible side effects you may feel when taking UPTRAVI®. If you experience any side effects not listed here, contact your healthcare professional.

Like all medicines, UPTRAVI® can cause side effects. You may experience side effects during the titration period and after taking the same dose for a long time.

If you experience any of these side effects below that you cannot tolerate or do not respond to treatment, talk to your doctor. The dose you are taking may be too high for you and may need to be reduced.

- headache
- jaw pain
- aching joints
- muscle pain or a general feeling of being in pain
- diarrhoea
- feeling sick to your stomach or throwing up
- stomach ache
- reddening of the face

Serious side effects and what to do about them			
Symptom / effect	Talk to your healthcare professional		Stop taking drug and get immediate medical help
	Only if severe	In all cases	
VERY COMMON			
Headache	✓		
Flushing (reddening of the face)	✓		
Nausea and vomiting (feeling sick to your stomach and throwing up)	✓		
Diarrhoea	✓		
Jaw pain, muscle pain, joint pain	✓		
Rash	✓		
COMMON			
Anaemia (low red blood cell levels)		✓	
Hyperthyroidism (overactive thyroid gland)		✓	
Decreased appetite	✓		
Hypotension (low blood pressure)		✓	
Stomach pain	✓		
Pain	✓		

If you have a troublesome symptom or side effect that is not listed here or becomes bad enough to interfere with your daily activities, talk to your healthcare professional.

Reporting Side Effects

You can report any suspected side effects associated with the use of health products to Health Canada by:

- Visiting the Web page on Adverse Reaction Reporting (<https://www.canada.ca/en/health-canada/services/drugs-health-products/medeffect-canada/adverse-reaction-reporting.html>) for information on how to report online, by mail or by fax; or
- Calling toll-free at 1-866-234-2345.

NOTE: Contact your health professional if you need information about how to manage your side effects. The Canada Vigilance Program does not provide medical advice.

Storage:

- Keep out of the sight and reach of children.
- Do not use UPTRAVI[®] after the expiration date, which is stated on the carton and on the blister after “EXP.” The expiration date refers to the last day of that month.
- Store at room temperature (15 to 30°C). Store UPTRAVI[®] in its original package.
- Do not throw away any medicines via wastewater or household waste. Ask your pharmacist how to dispose of medicines you no longer require. These measures will help to protect the environment.

If you want more information about UPTRAVI[®]:

- Talk to your healthcare professional
- Find the full product monograph that is prepared for healthcare professionals and includes this Patient Medication Information by visiting the Health Canada website (<https://health-products.canada.ca/dpd-bdpp/index-eng.jsp>), the manufacturer’s website (www.janssen.com/canada) or by calling 1-800-567-3331 and 1-800-387-8781.

This leaflet was prepared by Janssen Inc., Toronto, Ontario, M3C 1L9

Last Revised: June 19, 2020

All trademarks used under licence.

HIGHLIGHTS OF PRESCRIBING INFORMATION

These highlights do not include all the information needed to use UPTRAVI® safely and effectively. See full prescribing information for UPTRAVI®.

UPTRAVI® (selexipag) tablets, for oral use
Initial U.S. Approval: 2015

RECENT MAJOR CHANGES

Dosage and Administration (2.4) **09/2019**

INDICATIONS AND USAGE

UPTRAVI® is a prostacyclin receptor agonist indicated for the treatment of pulmonary arterial hypertension (PAH, WHO Group I) to delay disease progression and reduce the risk of hospitalization for PAH. (1.1)

DOSAGE AND ADMINISTRATION

- Starting dose: 200 mcg twice daily. (2.1)
- Increase the dose by 200 mcg twice daily at weekly intervals to the highest tolerated dose up to 1600 mcg twice daily. (2.1)
- Maintenance dose is determined by tolerability. (2.1)
- Moderate hepatic impairment: Starting dose 200 mcg once daily, increase the dose by 200 mcg once daily at weekly intervals to the highest tolerated dose up to 1600 mcg. (2.3)

DOSAGE FORMS AND STRENGTHS

Tablets: 200 mcg, 400 mcg, 600 mcg, 800 mcg, 1000 mcg, 1200 mcg, 1400 mcg, 1600 mcg. (3)

CONTRAINDICATIONS

Concomitant use with strong CYP2C8 inhibitors. (4, 7.1, 12.3)

WARNINGS AND PRECAUTIONS

Pulmonary edema in patients with pulmonary veno-occlusive disease. If confirmed, discontinue treatment. (5.1)

ADVERSE REACTIONS

Adverse reactions occurring more frequently ($\geq 5\%$) on UPTRAVI compared to placebo are headache, diarrhea, jaw pain, nausea, myalgia, vomiting, pain in extremity, and flushing. (6.1)

To report SUSPECTED ADVERSE REACTIONS, contact Actelion at 1-866-228-3546 or FDA at 1-800-FDA-1088 or www.fda.gov/medwatch.

DRUG INTERACTIONS

- Moderate CYP2C8 inhibitors (e.g., clopidogrel, deferasirox and teriflunomide) increase exposure to the active metabolite of UPTRAVI. Reduce the dosing of UPTRAVI to once daily (2.4, 7.1, 12.3).
- CYP2C8 inducers (e.g., rifampin) decrease exposure to the active metabolite. Increase up to twice the dose of UPTRAVI (7.2, 12.3)

USE IN SPECIFIC POPULATIONS

- Nursing mothers: discontinue UPTRAVI or breastfeeding. (8.2)
- Severe hepatic impairment: Avoid use. (8.6)

See 17 for PATIENT COUNSELING INFORMATION and FDA-approved patient labeling.

Revised: 09/2019

FULL PRESCRIBING INFORMATION: CONTENTS*

1 INDICATIONS AND USAGE

1.1 Pulmonary Arterial Hypertension

2 DOSAGE AND ADMINISTRATION

2.1 Recommended Dosage

2.2 Interruptions and Discontinuations

2.3 Dosage Adjustment in Patients with Hepatic Impairment

2.4 Dosage Adjustment with Co-administration of Moderate CYP2C8 Inhibitors

3 DOSAGE FORMS AND STRENGTHS

4 CONTRAINDICATIONS

5 WARNINGS AND PRECAUTIONS

5.1 Pulmonary Veno-Occlusive Disease (PVOD)

6 ADVERSE REACTIONS

6.1 Clinical Trial Experience

6.2 Postmarketing Experience

7 DRUG INTERACTIONS

7.1 CYP2C8 Inhibitors

7.2 CYP2C8 Inducers

8 USE IN SPECIFIC POPULATIONS

8.1 Pregnancy

8.2 Lactation

8.4 Pediatric Use

8.5 Geriatric Use

8.6 Patients with Hepatic Impairment

8.7 Patients with Renal Impairment

10 OVERDOSAGE

11 DESCRIPTION

12 CLINICAL PHARMACOLOGY

12.1 Mechanism of Action

12.2 Pharmacodynamics

12.3 Pharmacokinetics

13 NONCLINICAL TOXICOLOGY

13.1 Carcinogenesis, Mutagenesis, Impairment of Fertility

14 CLINICAL STUDIES

14.1 Pulmonary Arterial Hypertension

16 HOW SUPPLIED/STORAGE AND HANDLING

17 PATIENT COUNSELING INFORMATION

*Sections or subsections omitted from the full prescribing information are not listed.

FULL PRESCRIBING INFORMATION

1 INDICATIONS AND USAGE

1.1 Pulmonary Arterial Hypertension

UPTRAVI is indicated for the treatment of pulmonary arterial hypertension (PAH, WHO Group I) to delay disease progression and reduce the risk of hospitalization for PAH.

Effectiveness was established in a long-term study in PAH patients with WHO Functional Class II-III symptoms.

Patients had idiopathic and heritable PAH (58%), PAH associated with connective tissue disease (29%), PAH associated with congenital heart disease with repaired shunts (10%) [*see Clinical Studies (14.1)*].

2 DOSAGE AND ADMINISTRATION

2.1 Recommended Dosage

The recommended starting dose of UPTRAVI is 200 micrograms (mcg) given twice daily. Tolerability may be improved when taken with food [*see Clinical Pharmacology (12.3)*].

Increase the dose in increments of 200 mcg twice daily, usually at weekly intervals, to the highest tolerated dose up to 1600 mcg twice daily. If a patient reaches a dose that cannot be tolerated, the dose should be reduced to the previous tolerated dose.

Do not split, crush, or chew tablets.

2.2 Interruptions and Discontinuations

If a dose of medication is missed, patients should take a missed dose as soon as possible unless the next dose is within the next 6 hours.

If treatment is missed for 3 days or more, restart UPTRAVI at a lower dose and then retitrate.

2.3 Dosage Adjustment in Patients with Hepatic Impairment

No dose adjustment of UPTRAVI is necessary for patients with mild hepatic impairment (Child-Pugh class A).

For patients with moderate hepatic impairment (Child-Pugh class B), the starting dose of UPTRAVI is 200 mcg once daily. Increase in increments of 200 mcg once daily at weekly intervals, as tolerated [*see Use in Specific Populations (8.6), and Clinical Pharmacology (12.3)*].

Avoid use of UPTRAVI in patients with severe hepatic impairment (Child-Pugh class C).

2.4 Dosage Adjustment with Co-administration of Moderate CYP2C8 Inhibitors

When co-administered with moderate CYP2C8 inhibitors (e.g., clopidogrel, deferasirox and teriflunomide), reduce the dosing of UPTRAVI to once daily. Revert back to twice daily dosing frequency of UPTRAVI when co-administration of moderate CYP2C8 inhibitor is stopped [*see Drug Interactions (7.1) and Clinical Pharmacology (12.3)*].

3 DOSAGE FORMS AND STRENGTHS

UPTRAVI is available in the following strengths:

- 200 mcg [Light yellow tablet debossed with 2]
- 400 mcg [Red tablet debossed with 4]
- 600 mcg [Light violet tablet debossed with 6]
- 800 mcg [Green tablet debossed with 8]
- 1000 mcg [Orange tablet debossed with 10]
- 1200 mcg [Dark violet tablet debossed with 12]
- 1400 mcg [Dark yellow tablet debossed with 14]
- 1600 mcg [Brown tablet debossed with 16]

4 CONTRAINDICATIONS

Concomitant use of strong inhibitors of CYP2C8 (e.g., gemfibrozil) [*see Drug Interactions (7.1) and Clinical Pharmacology (12.3)*].

5 WARNINGS AND PRECAUTIONS

5.1 Pulmonary Veno-Occlusive Disease (PVOD)

Should signs of pulmonary edema occur, consider the possibility of associated PVOD. If confirmed, discontinue UPTRAVI.

6 ADVERSE REACTIONS

6.1 Clinical Trial Experience

Because clinical trials are conducted under widely varying conditions, adverse reaction rates observed in the clinical trials of a drug cannot be directly compared to rates in the clinical trials of another drug and may not reflect the rates observed in practice.

The safety of UPTRAVI has been evaluated in a long-term, placebo-controlled study enrolling 1156 patients with symptomatic PAH (GRIPHON study) [*see Clinical Studies (14)*]. The exposure to UPTRAVI in this trial was up to 4.2 years with median duration of exposure of 1.4 years.

Table 1 presents adverse reactions more frequent on UPTRAVI than on placebo by $\geq 3\%$.

Table 1 Adverse Reactions

<i>Adverse Reaction</i>	UPTRAVI N=575	Placebo N=577
Headache	65%	32%
Diarrhea	42%	18%
Jaw pain	26%	6%
Nausea	33%	18%
Myalgia	16%	6%
Vomiting	18%	9%
Pain in extremity	17%	8%
Flushing	12%	5%
Arthralgia	11%	8%
Anemia	8%	5%
Decreased appetite	6%	3%
Rash	11%	8%

These adverse reactions are more frequent during the dose titration phase.

Hyperthyroidism was observed in 1% (n=8) of patients on UPTRAVI and in none of the patients on placebo.

Laboratory Test Abnormalities

Hemoglobin

In a Phase 3 placebo-controlled study in patients with PAH, mean absolute changes in hemoglobin at regular visits compared to baseline ranged from -0.34 to -0.02 g/dL in the selexipag group compared to -0.05 to 0.25 g/dL in the placebo group. A decrease in hemoglobin concentration to below 10 g/dL was reported in 8.6% of patients treated with selexipag and 5.0% of placebo-treated patients.

Thyroid function tests

In a Phase 3 placebo-controlled study in patients with PAH, a reduction (up to -0.3 MU/L from a baseline median of 2.5 MU/L) in median thyroid-stimulating hormone (TSH) was observed at most visits in the selexipag group. In the placebo group, little change in median values was apparent. There were no mean changes in triiodothyronine or thyroxine in either group.

6.2 Postmarketing Experience

The following adverse reactions have been identified during postapproval use of UPTRAVI. Because these reactions are reported voluntarily from a population of uncertain size, it is not always possible to reliably estimate their frequency or establish a causal relationship to drug exposure.

Symptomatic hypotension

7 DRUG INTERACTIONS

7.1 CYP2C8 Inhibitors

Concomitant administration with gemfibrozil, a strong inhibitor of CYP2C8, doubled exposure to selexipag and increased exposure to the active metabolite by approximately 11-fold. Concomitant administration of UPTRAVI with strong inhibitors of CYP2C8 (e.g., gemfibrozil) is contraindicated [see *Contraindications (4) and Clinical Pharmacology (12.3)*].

Concomitant administration of UPTRAVI with clopidogrel, a moderate inhibitor of CYP2C8, had no relevant effect on the exposure to selexipag and increased the exposure to the active metabolite by approximately 2.7-fold [see *Clinical Pharmacology (12.3)*]. Reduce the dosing of UPTRAVI to once daily in patients on a moderate CYP2C8 inhibitor [see *Dosage and Administration (2.4)*].

7.2 CYP2C8 Inducers

Concomitant administration with an inducer of CYP2C8 and UGT 1A3 and 2B7 enzymes (rifampin) halved exposure to the active metabolite. Increase dose up to twice of UPTRAVI when co-administered with rifampin. Reduce UPTRAVI when rifampin is stopped [see *Clinical Pharmacology (12.3)*].

8 USE IN SPECIFIC POPULATIONS

8.1 Pregnancy

Risk Summary

There are no adequate and well-controlled studies with UPTRAVI in pregnant women. Animal reproduction studies performed with selexipag showed no clinically relevant effects on embryofetal development and survival. A slight reduction in maternal as well as in fetal body weight was observed when pregnant rats were administered selexipag during organogenesis at a dose producing an exposure approximately 47 times that in humans at the maximum recommended human dose. No adverse developmental outcomes were observed with oral administration of selexipag to pregnant rabbits during organogenesis at exposures up to 50 times the human exposure at the maximum recommended human dose.

The estimated background risk of major birth defects and miscarriage for the indicated population is unknown. In the U.S. general population, the estimated background risk of major birth defects and miscarriage in clinically recognized pregnancies is 2-4% and 15-20%, respectively.

Data

Animal Data

Pregnant rats were treated with selexipag using oral doses of 2, 6, and 20 mg/kg/day (up to 47 times the exposure at the maximum recommended human dose of 1600 mcg twice daily on an area under the curve [AUC] basis) during the period of organogenesis (gestation days 7 to 17). Selexipag did not cause adverse developmental effects to the fetus in this study. A slight reduction in fetal body weight was observed in parallel with a slight reduction in maternal body weight at the high dose.

Pregnant rabbits were treated with selexipag using oral doses of 3, 10, and 30 mg/kg (up to 50 times the exposure to the active metabolite at the maximum recommended human dose of 1600 mcg twice daily on an AUC basis) during the period of organogenesis (gestation days 6 to 18). Selexipag did not cause adverse developmental effects to the fetus in this study.

8.2 Lactation

It is not known if UPTRAVI is present in human milk. Selexipag or its metabolites were present in the milk of rats. Because many drugs are present in the human milk and because of the potential for serious adverse reactions in nursing infants, discontinue nursing or discontinue UPTRAVI.

8.4 Pediatric Use

Safety and effectiveness in pediatric patients have not been established.

8.5 Geriatric Use

Of the 1368 subjects in clinical studies of UPTRAVI 248 subjects were 65 years of age and older, while 19 were 75 and older. No overall differences were observed between these subjects and younger subjects, and other reported clinical experience has not identified differences in responses between the elderly and younger patients, but greater sensitivity cannot be ruled out.

8.6 Patients with Hepatic Impairment

No adjustment to the dosing regimen is needed in patients with mild hepatic impairment (Child-Pugh class A).

A once-daily regimen is recommended in patients with moderate hepatic impairment (Child-Pugh class B) due to the increased exposure to selexipag and its active metabolite. There is no experience with UPTRAVI in patients with severe hepatic impairment (Child-Pugh class C). Avoid use of UPTRAVI in patients with severe hepatic impairment [*see Dosage and Administration (2.3) and Clinical Pharmacology (12.3)*].

8.7 Patients with Renal Impairment

No adjustment to the dosing regimen is needed in patients with estimated glomerular filtration rate > 15 mL/min/1.73 m².

There is no clinical experience with UPTRAVI in patients undergoing dialysis or in patients with glomerular filtration rates < 15 mL/min/1.73 m² [*see Clinical Pharmacology (12.3)*].

10 OVERDOSAGE

Isolated cases of overdose up to 3200 mcg were reported. Mild, transient nausea was the only reported consequence. In the event of overdose, supportive measures must be taken as required. Dialysis is unlikely to be effective because selexipag and its active metabolite are highly protein-bound.

11 DESCRIPTION

UPTRAVI (selexipag) is a selective non-prostanoid IP prostacyclin receptor agonist. The chemical name of selexipag is 2-{4-[(5,6-diphenylpyrazin-2-yl)(isopropyl)amino]butoxy}-N-(methylsulfonyl) acetamide. It has a molecular formula of $C_{26}H_{32}N_4O_4S$ and a molecular weight of 496.62. Selexipag has the following structural formula:

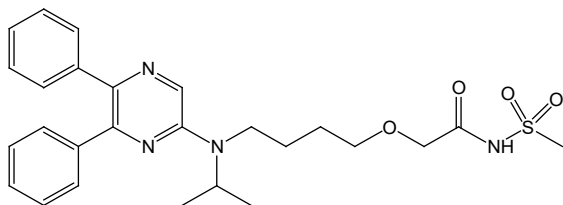

Selexipag is a pale yellow crystalline powder that is practically insoluble in water. In the solid state selexipag is very stable, is not hygroscopic, and is not light sensitive.

Depending on the dose strength, each round film-coated tablet for oral administration contains 200, 400, 600, 800, 1000, 1200, 1400, or 1600 mcg of selexipag. The tablets include the following inactive ingredients: D-mannitol, corn starch, low substituted hydroxypropylcellulose, hydroxypropylcellulose, and magnesium stearate. The tablets are film coated with a coating material containing hypromellose, propylene glycol, titanium dioxide, carnauba wax along with mixtures of iron oxide red, iron oxide yellow or iron oxide black.

12 CLINICAL PHARMACOLOGY

12.1 Mechanism of Action

Selexipag is an oral prostacyclin receptor (IP receptor) agonist that is structurally distinct from prostacyclin. Selexipag is hydrolyzed by carboxylesterase 1 to yield its active metabolite, which is approximately 37-fold as potent as selexipag. Selexipag and the active metabolite are selective for the IP receptor versus other prostanoid receptors (EP_{1-4} , DP, FP, and TP).

12.2 Pharmacodynamics

Cardiac electrophysiology:

At the maximum tolerated dose of 1600 mcg twice daily, selexipag does not prolong the QT interval to any clinically relevant extent.

Platelet aggregation:

Both selexipag and its active metabolite caused concentration-dependent inhibition of platelet aggregation *in vitro* with an IC₅₀ of 5.5 μM and 0.21 μM, respectively. However, at clinically relevant concentrations, there was no effect on platelet aggregation test parameters as seen following multiple-dose administrations of selexipag in healthy subjects from 400 mcg up to 1800 mcg twice daily.

Pulmonary hemodynamics:

A Phase 2 clinical study assessed hemodynamic variables after 17 weeks of treatment in patients with PAH WHO Functional Class II–III and concomitantly receiving endothelin receptor antagonists (ERAs) and/or phosphodiesterase type 5 (PDE-5) inhibitors. Patients titrating selexipag to an individually tolerated dose (200 mcg twice daily increments up to 800 mcg twice daily) (N=33) achieved a statistically-significant mean reduction in pulmonary vascular resistance of 30.3% (95% confidence interval [CI] –44.7%, –12.2%) and an increase in cardiac index (median treatment effect) of 0.41 L/min/m² (95% CI 0.10, 0.71) compared to placebo (N=10).

Drug interaction:

In a study in healthy subjects, selexipag (400 mcg twice a day) did not influence the pharmacodynamic effect of warfarin on the international normalized ratio.

12.3 Pharmacokinetics

The pharmacokinetics of selexipag and its active metabolite have been studied primarily in healthy subjects. The pharmacokinetics of selexipag and the active metabolite, after both single- and multiple-dose administration, were dose-proportional up to a single dose of 800 mcg and multiple doses of up to 1800 mcg twice daily.

In healthy subjects, inter-subject variability in exposure (area under the curve over a dosing interval, AUC) at steady-state was 43% and 39% for selexipag and the active metabolite, respectively. Intra-subject variability in exposure was 24% and 19% for selexipag and the active metabolite, respectively.

Exposures to selexipag and the active metabolite at steady-state in PAH patients and healthy subjects were similar. The pharmacokinetics of selexipag and the active metabolite in PAH patients were not influenced by the severity of the disease and did not change with time.

Both in healthy subjects and PAH patients, after oral administration, exposure at steady-state to the active metabolite is approximately 3- to 4-fold that of selexipag. Exposure to the active metabolite is approximately 30% higher after oral administration compared to the same intravenous dose in healthy subjects.

Absorption

The absolute bioavailability of selexipag is approximately 49%. Upon oral administration, maximum observed plasma concentrations of selexipag and its active metabolite are reached within about 1–3 hours and 3–4 hours, respectively.

In the presence of food, the absorption of selexipag was prolonged resulting in a delayed time to peak concentration (T_{max}) and ~30% lower peak plasma concentration (C_{max}). The exposure to selexipag and the active metabolite (AUC) did not significantly change in the presence of food.

Distribution

The volume of distribution of selexipag at steady state is 11.7 L.

Selexipag and its active metabolite are highly bound to plasma proteins (approximately 99% in total and to the same extent to albumin and alpha₁-acid glycoprotein).

Metabolism

Selexipag is hydrolyzed to its active metabolite, (free carboxylic acid) in the liver and intestine by carboxylesterases. Oxidative metabolism, catalyzed mainly by CYP2C8 and to a smaller extent by CYP3A4, leads to the formation of hydroxylated and dealkylated products. UGT1A3 and UGT2B7 are involved in the glucuronidation of the active metabolite. Except for the active metabolite, none of the circulating metabolites in human plasma exceeds 3% of the total drug-related material.

Elimination

Elimination of selexipag is predominately via metabolism with a mean terminal half-life of 0.8-2.5 hours. The terminal half-life of the active metabolite is 6.2-13.5 hours. There is minimal accumulation of the active metabolite upon twice daily repeat administration suggesting that the effective half-life is in the range of 3-4 hours. The total body clearance of selexipag is 17.9 L/hour.

Excretion

In a study in healthy subjects with radiolabeled selexipag, approximately 93% of radioactive drug material was eliminated in feces and only 12% in urine. Neither selexipag nor its active metabolite were found in urine.

Specific Populations:

No clinically relevant effects of sex, race, age or body weight on the pharmacokinetics of selexipag and its active metabolite have been observed in healthy subjects or PAH patients.

Age:

The pharmacokinetic variables (C_{max} and AUC) were similar in adult and elderly subjects up to 75 years of age. There was no effect of age on the pharmacokinetics of selexipag and the active metabolite in PAH patients.

Hepatic Impairment:

In subjects with mild (*Child-Pugh class A*) or moderate (*Child-Pugh class B*) hepatic impairment, exposure to selexipag was 2- and 4-fold that seen in healthy subjects. Exposure to the active metabolite of selexipag remained almost unchanged in subjects with mild hepatic impairment and was doubled in subjects with moderate hepatic impairment [*see Use in Specific Populations (8.6)*].

Based on pharmacokinetic modeling of data from a study in subjects with hepatic impairment, the exposure to the active metabolite at steady state in subjects with moderate hepatic impairment (*Child-Pugh class B*) after a once daily regimen is expected to be similar to that in healthy subjects

receiving a twice daily regimen. The exposure to selexipag at steady state in these patients during a once daily regimen is predicted to be approximately 2-fold that seen in healthy subjects receiving a twice-daily regimen.

Renal Impairment:

A 40-70% increase in exposure (maximum plasma concentration and area under the plasma concentration-time curve) to selexipag and its active metabolite was observed in subjects with severe renal impairment (estimated glomerular filtration rate ≥ 15 mL/min/1.73 m² and < 30 mL/min/1.73 m²) [see *Use in Specific Populations (8.7)*].

Drug Interaction Studies:

In vitro studies

Selexipag is hydrolyzed to its active metabolite by carboxylesterases. Selexipag and its active metabolite both undergo oxidative metabolism mainly by CYP2C8 and to a smaller extent by CYP3A4. The glucuronidation of the active metabolite is catalyzed by UGT1A3 and UGT2B7. Selexipag and its active metabolite are substrates of OATP1B1 and OATP1B3. Selexipag is a substrate of P-gp, and the active metabolite is a substrate of the transporter of breast cancer resistance protein (BCRP).

Selexipag and its active metabolite do not inhibit or induce cytochrome P450 enzymes and transport proteins at clinically relevant concentrations.

The results on in vivo drug interaction studies are presented in Figure 1 and 2.

Figure 1 Effect of Other Drugs on UPTRAVI and its Active Metabolite

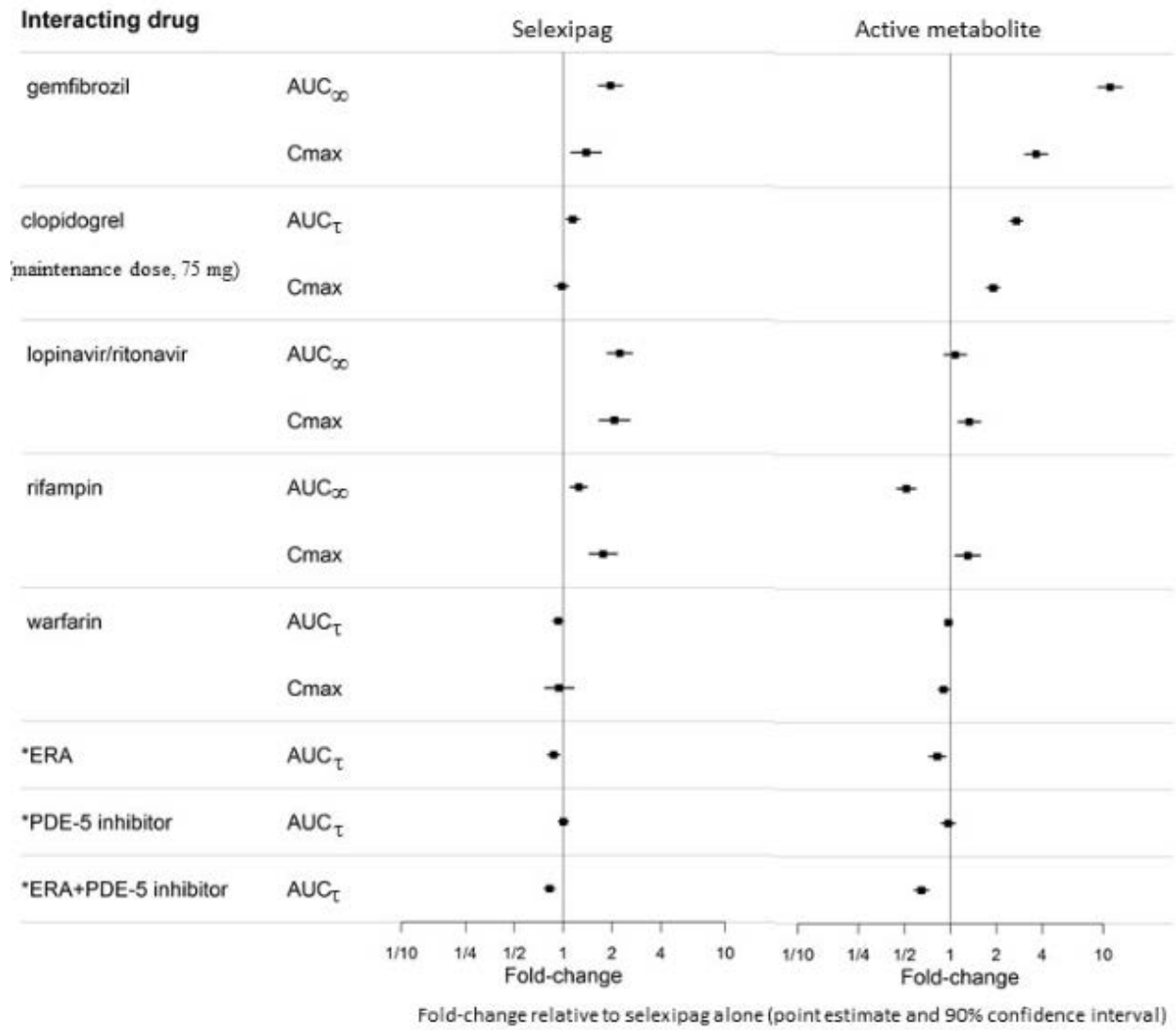

*ERA and PDE-5 inhibitor data from GRIPHON.

Figure 2 Effect of UPTRAVI on Other Drugs

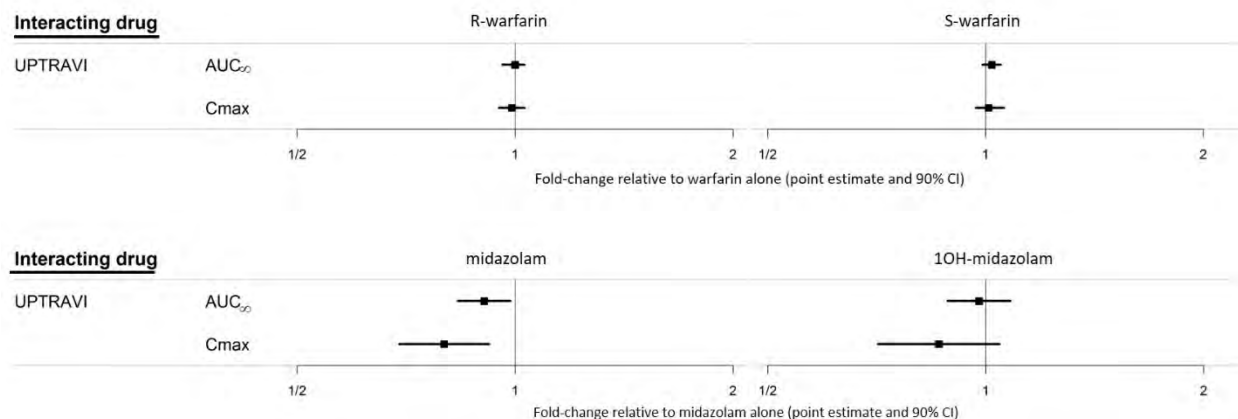

13 NONCLINICAL TOXICOLOGY

13.1 Carcinogenesis, Mutagenesis, Impairment of Fertility

Carcinogenesis: In the 2-year carcinogenicity studies, chronic oral administration of selexipag revealed no evidence of carcinogenic potential in rats at 100 mg/kg/day and mice at 500 mg/kg/day. The exposures were more than 25-fold human exposure.

Mutagenesis: Selexipag and the active metabolite are not genotoxic on the basis of the overall evidence of conducted genotoxicity studies.

Fertility: The no effect dose for effects on fertility was 60 mg/kg/day in a study in which rats were administered selexipag orally. This dose corresponded to an exposure of 175-times (active metabolite) the human therapeutic exposure.

14 CLINICAL STUDIES

14.1 Pulmonary Arterial Hypertension

The effect of selexipag on progression of PAH was demonstrated in a multi-center, double-blind, placebo-controlled, parallel group, event-driven study (GRIPHON) in 1156 patients with symptomatic (WHO Functional Class I [0.8%], II [46%], III [53%], and IV [1%]) PAH. Patients were randomized to either placebo (N = 582), or UPTRAVI (N = 574). The dose was increased in weekly intervals by increments of 200 mcg twice a day to the highest tolerated dose up to 1600 mcg twice a day.

The primary study endpoint was the time to first occurrence up to end-of-treatment of: a) death, b) hospitalization for PAH, c) PAH worsening resulting in need for lung transplantation, or balloon atrial septostomy, d) initiation of parenteral prostanoid therapy or chronic oxygen therapy, or e) other disease progression based on a 15% decrease from baseline in 6MWD plus worsening of Functional Class or need for additional PAH-specific therapy.

The mean age was 48 years, the majority of patients were white (65%) and female (80%). Nearly all patients were in WHO Functional Class II and III at baseline.

Idiopathic or heritable PAH was the most common etiology in the study population (58%) followed by PAH associated with connective tissue disease (29%), PAH associated with congenital heart disease with repaired shunts (10%), drugs and toxins (2%), and HIV (1%).

At baseline, the majority of enrolled patients (80%) were being treated with a stable dose of an endothelin receptor antagonist (15%), a PDE-5 inhibitor (32%), or both (33%).

Patients on selexipag achieved doses within the following groups: 200-400 mcg (23%), 600-1000 mcg (31%) and 1200-1600 mcg (43%).

Treatment with UPTRAVI resulted in a 40% reduction (99% CI: 22 to 54%; two-sided log-rank p -value < 0.0001) of the occurrence of primary endpoint events compared to placebo (Table 2; Figure 3). The beneficial effect of UPTRAVI was primarily attributable to a reduction in hospitalization for PAH and a reduction in other disease progression events (Table 2). The observed benefit of UPTRAVI was similar regardless of the dose achieved when patients were titrated to their highest tolerated dose [*see Dosage and Administration (2.1)*].

Figure 3 Kaplan-Meier Estimates of the First Morbidity-Mortality Event in GRIPHON

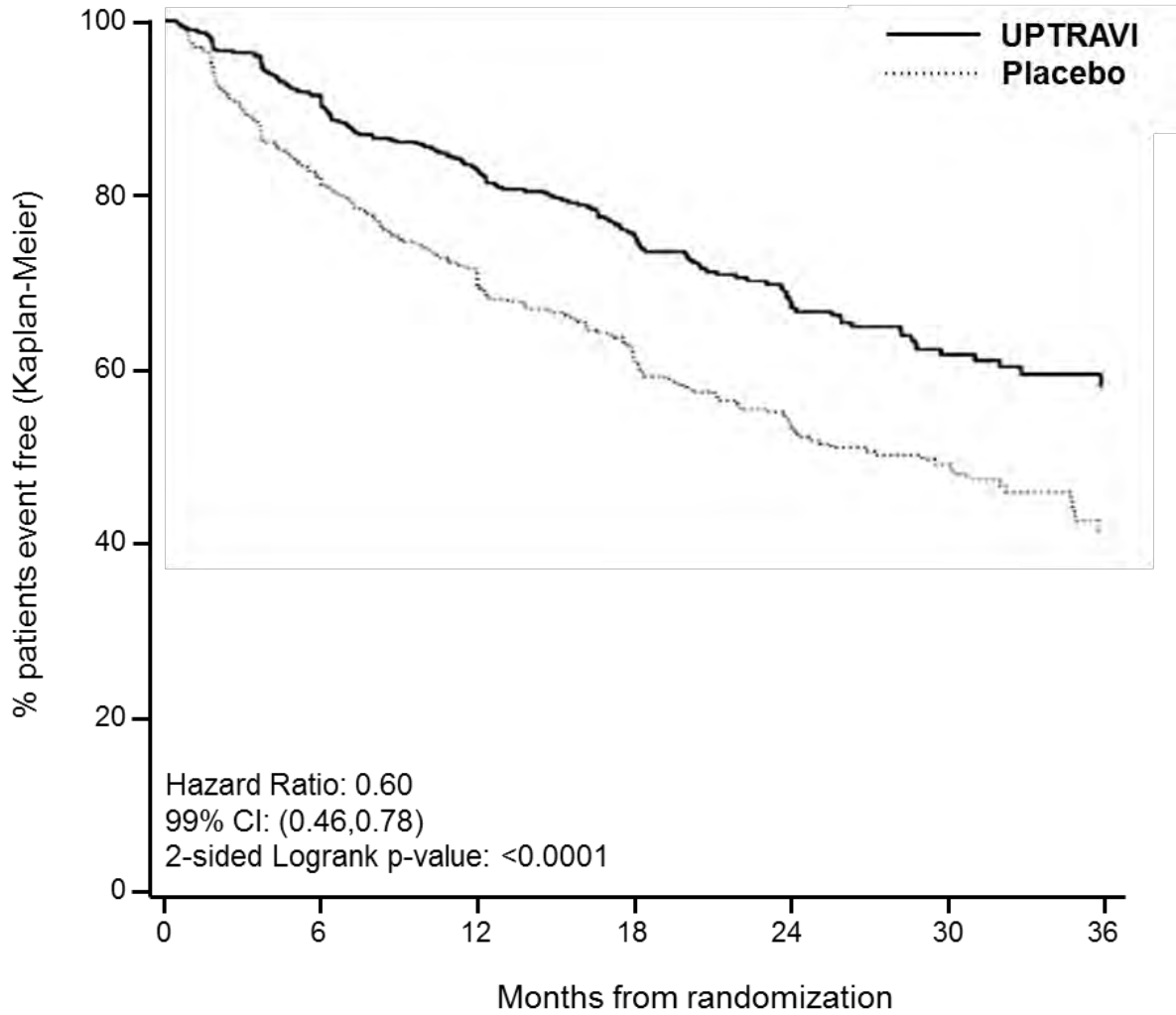

UPTRAVI patients:

at risk	574	455	361	246	171	101	40
---------	-----	-----	-----	-----	-----	-----	----

Placebo patients:

at risk	582	433	347	220	149	88	28
---------	-----	-----	-----	-----	-----	----	----

Table 2 Primary Endpoints and Related Components in GRIPHON

	UPTRAVI N=574		Placebo N=582		Hazard Ratio (99% CI)	p-value
	n	%	n	%		
Primary endpoint events up to the end of treatment						
All primary endpoint events	155	27.0	242	41.6	0.60 [0.46,0.78]	<0.0001
As first event:						
• Hospitalization for PAH	78	13.6	109	18.7		
• Other disease Progression (Decrease in 6MWD plus worsening functional class or need for other therapy)	38	6.6	100	17.2		
• Death	28	4.9	18	3.1		
• Parenteral prostanoid or chronic oxygen therapy	10	1.7	13	2.2		
• PAH worsening resulting in need for lung transplantation or balloon atrial septostomy	1	0.2	2	0.3		

It is not known if the excess number of deaths in the selexipag group is drug-related because there were so few deaths and the imbalance was not observed until 18 months into GRIPHON.

Figures 4A, B, and C show time to first event analyses for primary endpoint components of hospitalization for PAH (A), other disease progression (B), and death (C)—all censored 7 days after any primary end point event (because many patients on placebo transitioned to open-label UPTRAVI at this point).

Figure 4 A Hospitalization for PAH as the First Endpoint in GRIPHON

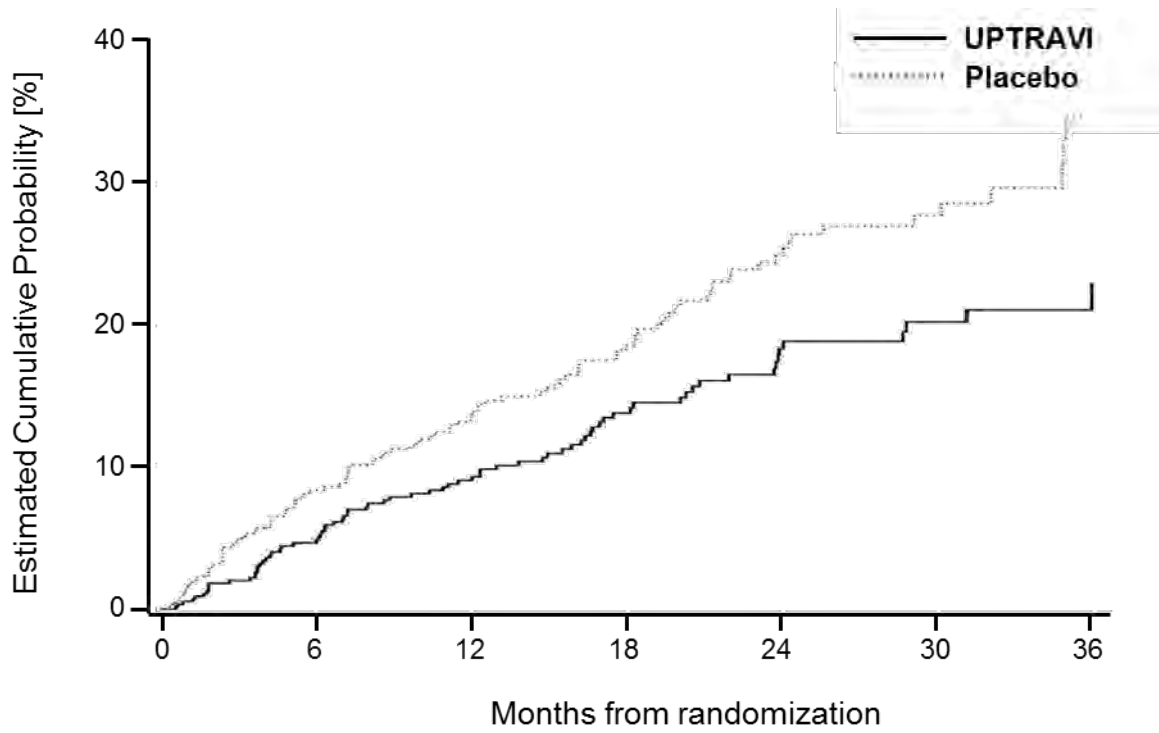

UPTRAVI patients:

at risk	574	455	361	246	171	101	40
---------	-----	-----	-----	-----	-----	-----	----

Placebo patients:

at risk	582	433	347	220	149	88	28
---------	-----	-----	-----	-----	-----	----	----

Figure 4B Disease Progression as the First Endpoint in GRIPHON

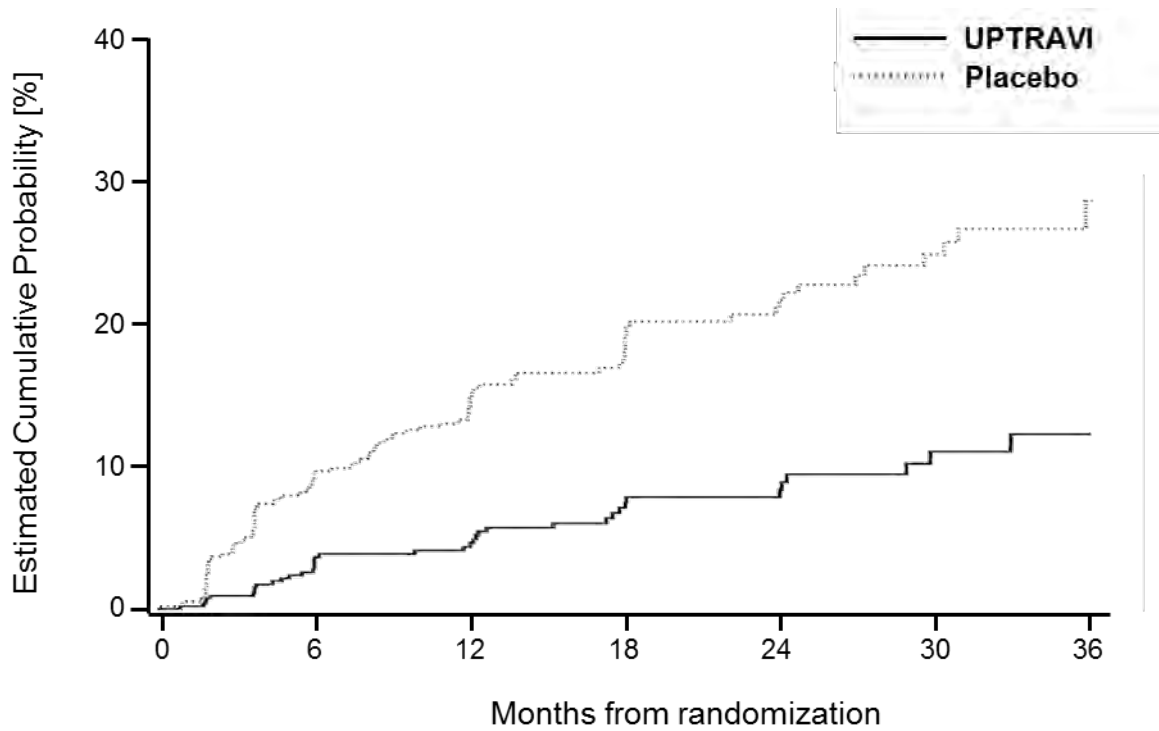

UPTRAVI patients:

at risk	574	455	361	246	171	101	40
---------	-----	-----	-----	-----	-----	-----	----

Placebo patients:

at risk	582	433	347	220	149	88	28
---------	-----	-----	-----	-----	-----	----	----

Figure 4C Death as the First Endpoint in GRIPHON

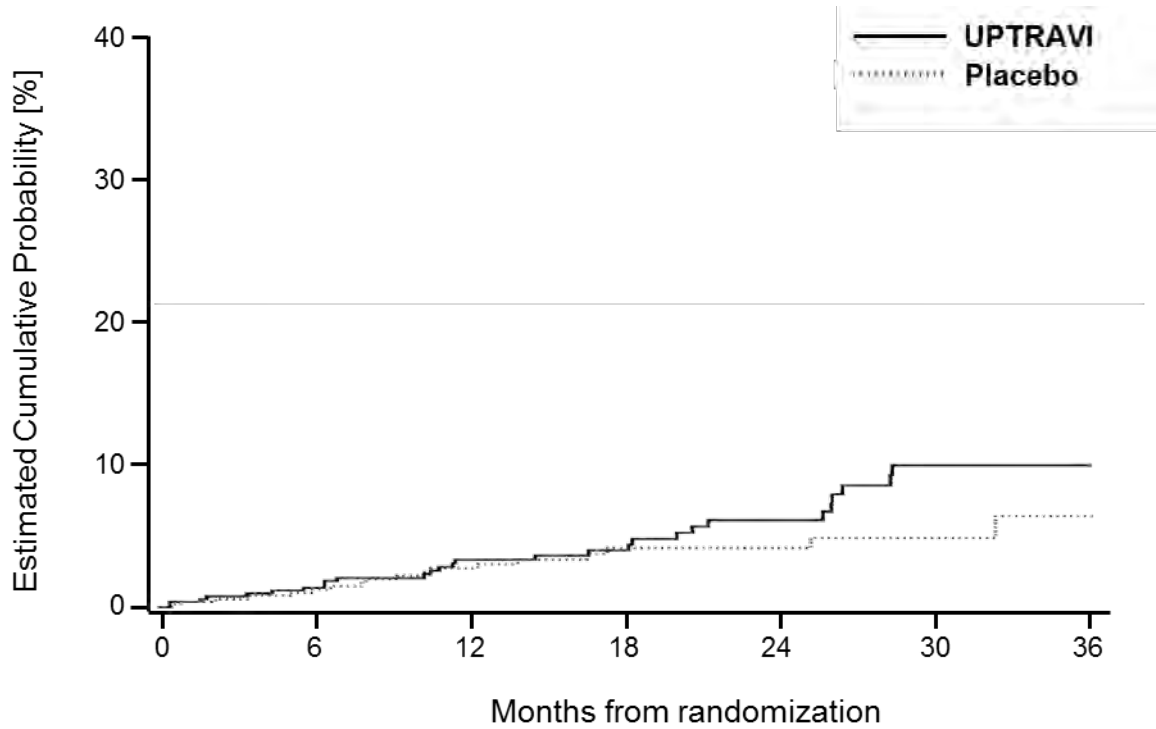

UPTRAVI patients:

at risk	574	455	361	246	171	101	40
---------	-----	-----	-----	-----	-----	-----	----

Placebo patients:

at risk	582	433	347	220	149	88	28
---------	-----	-----	-----	-----	-----	----	----

The treatment effect of UPTRAVI on time to first primary event was consistent irrespective of background PAH therapy (i.e., in combination with an ERA, PDE-5i, both, or without background therapy) (Figure 5).

Figure 5 Subgroup Analyses of the Primary Endpoint in GRIPHON

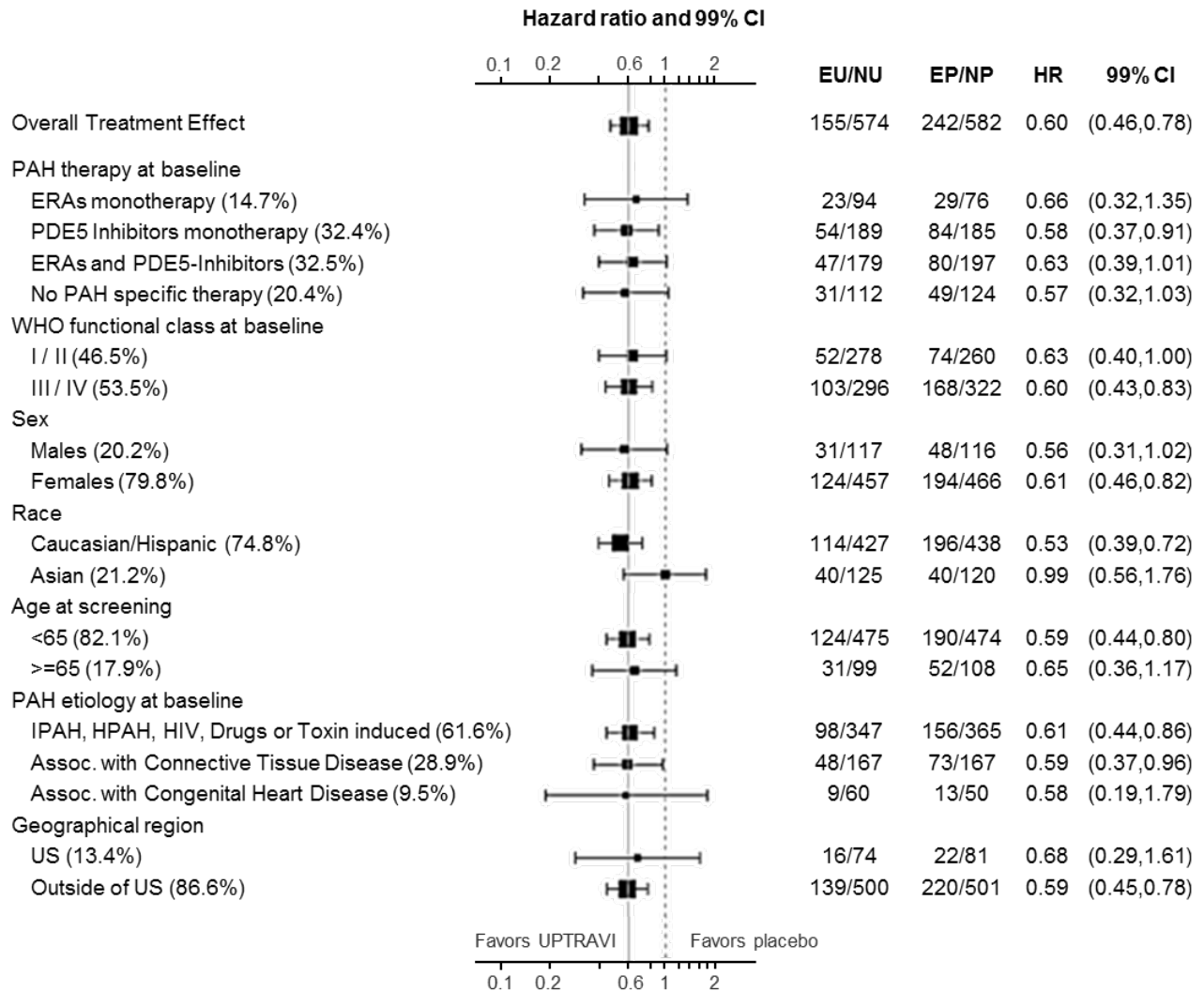

Note: Race group “Other” is not displayed in analysis, as the population is less than 30. EU = Number of UPTRAVI patients with events, NU = Number of patients randomized to UPTRAVI, EP = Number of Placebo patients with events, NP = Number of patients randomized to Placebo, HR = Hazard Ratio, CI = Confidence Interval, the size of the squares represent the number of patients in the subgroup.

Note: The figure above presents effects in various subgroups all of which are baseline characteristics and all were pre-specified. The 99% confidence limits that are shown do not take into account how many comparisons were made, nor do they reflect the effect of a particular factor after adjustment for all other factors. Apparent homogeneity or heterogeneity among groups should not be over-interpreted.

6-Minute Walk Distance (6MWD)

Exercise capacity was evaluated as a secondary endpoint. Median absolute change from baseline to week 26 in 6MWD measured at trough (i.e., at approximately 12 hours post-dose) was +4 meters with UPTRAVI and -9 meters in the placebo group. This resulted in a placebo-corrected median treatment effect of 12 meters (99% CI: 1, 24 meters; two-sided p = 0.005).

16 HOW SUPPLIED/STORAGE AND HANDLING

UPTRAVI (selexipag) film-coated, round tablets are supplied in the following configurations:

Strength (mcg)	Color	Debossing	NDC-XXX	
			Bottle of 60	Bottle of 140
200	Light yellow	2	66215-602-06	66215-602-14
400	Red	4	66215-604-06	Not Applicable
600	Light violet	6	66215-606-06	Not Applicable
800	Green	8	66215-608-06	Not Applicable
1000	Orange	10	66215-610-06	Not Applicable
1200	Dark violet	12	66215-612-06	Not Applicable
1400	Dark yellow	14	66215-614-06	Not Applicable
1600	Brown	16	66215-616-06	Not Applicable

UPTRAVI is also supplied in a Titration Pack [NDC 66215-628-20] that includes a 140 count bottle of 200 mcg tablets and a 60 count bottle of 800 mcg tablets.

Store at 20°C to 25°C (68°F to 77°F). Excursions are permitted between 15°C and 30°C (59°F and 86°F) [see USP Controlled Room Temperature].

17 PATIENT COUNSELING INFORMATION

Advise the patient to read the FDA-approved patient labeling (Patient Package Insert).

Inform patients:

- what to do if they miss a dose
- not to split, crush, or chew tablets.

Manufactured for:

Actelion Pharmaceuticals US, Inc.

5000 Shoreline Court, Ste. 200

South San Francisco, CA 94080, USA

ACT20190806

© 2017 Actelion Pharmaceuticals US, Inc. All rights reserved.

Patient Information
UPTRAVI (up-TRA-vee)
(selexipag) tablets

Read this Patient Information before you start taking UPTRAVI and each time you get a refill. There may be new information. This information does not take the place of talking to your healthcare provider about your medical condition or your treatment.

What is UPTRAVI?

- UPTRAVI is a prescription medicine used to treat pulmonary arterial hypertension (PAH) which is high blood pressure in the arteries of your lungs.
- UPTRAVI can help slow down the progression of your disease and lower your risk of being hospitalized for PAH.

It is not known if UPTRAVI is safe and effective in children.

Who should not take UPTRAVI?

Do not take UPTRAVI if you

Take gemfibrozil because this medicine may affect how UPTRAVI works and cause side effects.

What should I tell my healthcare provider before taking UPTRAVI?

Before you take UPTRAVI, tell your healthcare provider if you:

- have liver problems.
- have narrowing of the pulmonary veins, a condition called pulmonary veno-occlusive disease.
- are pregnant or plan to become pregnant. It is not known if UPTRAVI will harm your unborn baby.
- are breastfeeding or plan to breastfeed. It is not known if UPTRAVI passes into your breast milk. You and your healthcare provider should decide if you will take UPTRAVI or breastfeed. You should not do both.
- have any other medical conditions

Tell your healthcare provider about all the medicines you take, including prescription and over-the-counter medicines, vitamins, and herbal supplements. UPTRAVI and other medicines may affect each other causing side effects. Do not start any new medicine until you check with your healthcare provider.

How should I take UPTRAVI?

- Take UPTRAVI exactly as your healthcare provider tells you to take it. Do not stop taking UPTRAVI unless your healthcare provider tells you to stop.
- Your healthcare provider will slowly increase your dose to find the dose of UPTRAVI that is right for you.
- If you have side effects, your healthcare provider may tell you to change your dose of UPTRAVI.
- UPTRAVI can be taken with or without food. Taking UPTRAVI with food may help you tolerate UPTRAVI better.
- UPTRAVI is usually taken 2 times each day.
- Swallow UPTRAVI tablets whole. Do not split, crush or chew UPTRAVI tablets.
- If you miss a dose of UPTRAVI, take it as soon as you remember. If your next scheduled dose is due within 6 hours, skip the missed dose. Take the next dose at your regular time.
- If you miss 3 or more days of UPTRAVI, call your healthcare provider to see if your dose needs to be changed.
- If you take too much UPTRAVI, call your healthcare provider or go to the nearest hospital emergency room right away.

What are the possible side effects of UPTRAVI?

The most common side effects of UPTRAVI include:

- | | |
|------------------------|----------------------------|
| • Headache | • diarrhea |
| • jaw pain | • nausea |
| • muscle pain | • vomiting |
| • pain in arms or legs | • flushing |
| • pain in joints | • low red blood cell count |
| • decreased appetite | • rash |

These are not all of the possible side effects of UPTRAVI.

Call your doctor for medical advice about side effects. You may report side effects to FDA at 1-800-FDA-1088.

How should I store UPTRAVI?

- Store UPTRAVI tablets at room temperature between 68°F and 77°F (20°C and 25°C).

Keep UPTRAVI and all medicines out of the reach of children.

General information about the safe and effective use of UPTRAVI

Medicines are sometimes prescribed for purposes other than those listed in a Patient Information leaflet.

Do not use UPTRAVI for a condition for which it was not prescribed. Do not give UPTRAVI to other people, even if they have the same symptoms that you have. It may harm them. You can ask your healthcare provider or pharmacist for information about UPTRAVI that is written for health professionals.

What are the ingredients in UPTRAVI?

Active ingredient: selexipag

Inactive ingredients: D-mannitol, corn starch, low substituted hydroxypropylcellulose, hydroxypropylcellulose, and magnesium stearate. The tablets are film coated with a coating material containing hypromellose, propylene glycol, titanium dioxide, carnauba wax along with iron oxide red, iron oxide yellow, or iron oxide black.

Manufactured for: Actelion Pharmaceutical US, Inc. 5000 Shoreline Court, Ste. 200 South San Francisco, CA 94080, USA
ACT20190806

©2017 Actelion Pharmaceuticals US, Inc. All rights reserved.

For more information, call 1-866-228-3546 or go to www.UPTRAVI.com.

The Patient Information has been approved by the U.S. Food and Drug Administration.

Issued: 09/2019

PRODUCT MONOGRAPH

Pr VENTOLIN HFA

salbutamol sulfate inhalation aerosol

(100 mcg salbutamol/metered dose)

Bronchodilator

(beta₂-adrenergic agonist)

GlaxoSmithKline Inc.
7333 Mississauga Road
Mississauga, Ontario
L5N 6L4
www.gsk.ca

Date of Revision:
November 17, 2017

Submission Control No. : 207156

© 2017 GSK group of companies or its licensor.
Trademarks are owned by or licensed to the GSK group of companies.

Table of Contents

PART I: HEALTH PROFESSIONAL INFORMATION.....	3
SUMMARY PRODUCT INFORMATION	3
INDICATIONS AND CLINICAL USE.....	3
CONTRAINDICATIONS	3
WARNINGS AND PRECAUTIONS.....	3
ADVERSE REACTIONS.....	7
DRUG INTERACTIONS	9
DOSAGE AND ADMINISTRATION	10
OVERDOSAGE	12
ACTION AND CLINICAL PHARMACOLOGY	12
STORAGE AND STABILITY.....	14
SPECIAL HANDLING INSTRUCTIONS	14
DOSAGE FORMS, COMPOSITION AND PACKAGING	14
PART II: SCIENTIFIC INFORMATION	15
PHARMACEUTICAL INFORMATION.....	15
CLINICAL TRIALS.....	16
DETAILED PHARMACOLOGY	17
TOXICOLOGY	19
PART III: CONSUMER INFORMATION.....	21

PrVENTOLIN HFA

salbutamol sulfate inhalation aerosol

PART I: HEALTH PROFESSIONAL INFORMATION

SUMMARY PRODUCT INFORMATION

Route of Administration	Dosage Form / Strength	Nonmedicinal Ingredients
Oral Inhalation	inhalation aerosol / 100 mcg salbutamol	1, 1, 1, 2-tetrafluoroethane (HFA-134a)

INDICATIONS AND CLINICAL USE

Adults and Children (4 years and older):

VENTOLIN HFA (salbutamol sulfate) inhalation aerosol is indicated for:

- the symptomatic relief and prevention of bronchospasm due to bronchial asthma, chronic bronchitis and other chronic bronchopulmonary disorders in which bronchospasm is a complicating factor.
- the prevention of exercise-induced bronchospasm.

Pediatrics (<4 years of age):

The safety and efficacy in children below the age of 4 years has not been established.

CONTRAINDICATIONS

- Patients who are hypersensitive to this drug or to any ingredient in the formulation or component of the container (see DOSAGE FORMS, COMPOSITION AND PACKAGING).
- As a tocolytic in patients at risk of premature labour or threatened abortion.

WARNINGS AND PRECAUTIONS

General

Patients should always carry their VENTOLIN HFA (salbutamol sulfate) inhalation aerosol to use immediately if an episode of asthma is experienced. If therapy does not produce a significant improvement or if the patient's condition worsens, medical advice must be sought to determine a new plan of treatment. In the case of acute or rapidly worsening dyspnea, a doctor should be consulted immediately

Deterioration of Asthma

Asthma may deteriorate over time. If the patient needs to use VENTOLIN HFA more often than usual, this may be a sign of worsening asthma. This requires re-evaluation of the patient and treatment plan and consideration of adjusting the asthma maintenance therapy. If inhaled salbutamol treatment alone is not adequate to control asthma, concomitant anti-inflammatory therapy should be part of the treatment regimen. It is essential that the physician instruct the patient in the need for further evaluation if the patient's asthma becomes worse (see DOSAGE AND ADMINISTRATION).

Cardiovascular

In individual patients, any beta₂-adrenergic agonist, including salbutamol, may have a clinically significant cardiac effect. Care should be taken with patients suffering from cardiovascular disorders, especially coronary insufficiency, cardiac arrhythmias and hypertension. Special care and supervision are required in patients with idiopathic hypertrophic subvalvular aortic stenosis, in whom an increase in the pressure gradient between the left ventricle and the aorta may occur, causing increased strain on the left ventricle.

Fatalities have been reported in association with excessive use of inhaled sympathomimetic drugs in patients with asthma. The exact cause of death is unknown, but cardiac arrest following an unexpected development of a severe acute asthmatic crisis and subsequent hypoxia is suspected.

Endocrine and Metabolism

Metabolic Effects

In common with other beta-adrenergic agents, salbutamol sulfate can induce reversible metabolic changes such as potentially serious hypokalemia, particularly following nebulised or especially infused administration. Particular caution is advised in acute severe asthma since hypokalemia may be potentiated by concomitant treatment with xanthine derivatives, steroids and diuretics and by hypoxia. Hypokalemia will increase the susceptibility of digitalis-treated patients to cardiac arrhythmias. It is recommended that serum potassium levels be monitored in such situations.

Care should be taken with patients with diabetes mellitus. Salbutamol can induce reversible hyperglycemia during nebulised administration or especially during infusions of the drug. The diabetic patient may be unable to compensate for this and the development of ketoacidosis has been reported. Concurrent administration of corticosteroids can exaggerate this effect.

Care should be taken with patients with hyperthyroidism.

Hypersensitivity

Immediate hypersensitivity reactions may occur after administration of salbutamol sulfate, as demonstrated by rare cases of urticaria, angioedema, rash, bronchospasm, hypotension, anaphylaxis and oropharyngeal edema.

Care should be taken in patients who are unusually responsive to sympathomimetic amines.

Neurologic

Care should be taken with patients with convulsive disorders.

Respiratory

As with other inhaled medications, paradoxical bronchospasm may occur characterized by an immediate increase in wheezing after dosing. This should be treated immediately with an alternative presentation or a different fast-acting inhaled bronchodilator to relieve acute asthmatic symptoms. VENTOLIN HFA should be discontinued immediately, the patient assessed and if necessary, alternative therapy instituted (see ADVERSE REACTIONS).

Special Populations

Pregnant Women: Salbutamol has been in widespread use for many years in humans without apparent ill consequence. However, there are no adequate and well-controlled studies in pregnant women and there is little published evidence of its safety in the early stages of human pregnancy. Administration of any drug to pregnant women should only be considered if the anticipated benefits to the expectant woman are greater than any possible risks to the fetus (see TOXICOLOGY, Teratogenicity Studies).

During worldwide marketing experience, rare cases of various congenital anomalies, including cleft palate and limb defects have been reported in the offspring of patients being treated with salbutamol. Some of the mothers were taking multiple medications during their pregnancies. Because no consistent pattern of defects can be discerned, and baseline rate for congenital anomalies is 2-3%, a relationship with salbutamol use cannot be established.

Labour & Delivery: Because of the potential for beta-agonist interference with uterine contractility, use of VENTOLIN HFA for relief of bronchospasm during labour should be restricted to those patients in whom the benefits clearly outweigh the risks.

Nursing Women: Plasma levels of salbutamol sulfate and HFA-134a after inhaled therapeutic doses are very low in humans, but it is not known whether the components are excreted in human milk. Because of the potential for tumorigenicity shown for salbutamol in some animal studies, a decision should be made whether to discontinue nursing or to discontinue the drug, taking into account the benefit of the

drug to the mother. It is not known whether salbutamol in breast milk has a harmful effect on the neonate.

Pediatrics (4 to < 12 years): The use of metered-dose inhalers in children depends on the ability of the individual child to learn the proper use of this device. Metered-dose inhalers with spacers are recommended for children under 5 years of age, especially for administration of inhaled corticosteroids. Conversion from a face mask to a mouthpiece is strongly encouraged as soon as the age and the cooperation of the child permit.

During inhalation, children should be assisted or supervised by an adult who knows the proper use of the device.

Rarely, in children, hyperactivity occurs and occasionally, sleep disturbances, hallucination or atypical psychosis have been reported.

Pediatrics (< 4 years of age): The safety and efficacy in children below the age of 4 years has not been established.

Geriatrics: As with other beta₂-agonists, special caution should be observed when using VENTOLIN HFA in elderly patients who have concomitant cardiovascular disease that could be adversely affected by this class of drug.

Monitoring and Laboratory Tests

In accordance with the present practice for asthma treatment, patient response should be monitored clinically and by lung function tests.

Monitoring Control of Asthma

Failure to respond for at least three hours to a previously effective dose of VENTOLIN HFA indicates a deterioration of the condition and the physician should be contacted promptly. Patients should be warned not to exceed the recommended dose as there may be adverse effects associated with excessive dosing.

The increasing use of fast-acting, short duration inhaled beta₂-adrenergic agonists to control symptoms indicates deterioration of asthma control and the patient's therapy plan should be reassessed. In worsening asthma it is inadequate to increase beta₂-agonist use only, especially over an extended period of time. In the case of acute or rapidly worsening dyspnea, a doctor should be consulted immediately. Sudden or progressive deterioration in asthma control is potentially life threatening; the treatment plan must be re-evaluated, and consideration be given to corticosteroid therapy (see DOSAGE AND ADMINISTRATION).

ADVERSE REACTIONS

Adverse Drug Reaction Overview

As with other bronchodilator inhalation therapy, the potential for paradoxical bronchospasm should be kept in mind. If it occurs, the preparation should be discontinued immediately and alternative therapy instituted.

Potentially serious hypokalemia may result from beta₂-agonist therapy primarily from parenteral and nebulised routes of administration (see WARNINGS and PRECAUTIONS, Endocrine and Metabolism).

Peripheral vasodilation and a compensatory small increase in heart rate may occur in some patients. Cardiac arrhythmias (including atrial fibrillation, supraventricular tachycardia, extrasystoles) have been reported, usually in susceptible patients.

Other adverse reactions associated with salbutamol are nervousness and tremor. In some patients inhaled salbutamol may cause a fine tremor of skeletal muscle, particularly in the hands. This effect is common to all beta₂-adrenergic agonists. Adaptation occurs during the first few days of dosing and the tremor usually disappears as treatment continues.

In addition, salbutamol, like other sympathomimetic agents, can cause adverse effects such as drowsiness, flushing, restlessness, irritability, chest discomfort, difficulty in micturition, hypertension, angina, vomiting, vertigo, central nervous system stimulation, hyperactivity in children, unusual taste and drying or irritation of the oropharynx, headache, palpitations, transient muscle cramps, insomnia, nausea, weakness and dizziness.

Immediate hypersensitivity reactions including angioedema, urticaria, bronchospasm, hypotension, rash, oropharyngeal oedema, anaphylaxis and collapse have been reported very rarely.

Rarely, in children, hyperactivity occurs and occasionally, sleep disturbances, hallucination or atypical psychosis have been reported.

Clinical Trial Adverse Drug Reactions

Because clinical trials are conducted under very specific conditions the adverse reaction rates observed in the clinical trials may not reflect the rates observed in practice and should not be compared to the rates in the clinical trials of another drug. Adverse drug reaction information from clinical trials is useful for identifying drug-related adverse events and for approximating rates.

Adverse reaction information concerning VENTOLIN HFA (salbutamol sulfate) inhalation aerosol is derived from two 12-week, randomized, double-blind studies in 610 adolescent and adult asthmatic patients that compared VENTOLIN HFA,

VENTOLIN inhalation aerosol (CFC formulation), and an HFA-134a placebo inhaler.

Table 1 Adverse experience incidence (% of patients) in two large 12-week adolescent and adult clinical trials*

	VENTOLIN HFA n= 202 (% patients)	VENTOLIN (CFC formulation) n= 207 (% patients)	Placebo (HFA-134a) n= 201 (% patients)
Ear, Nose and Throat			
Throat irritation	10	6	7
Upper respiratory inflammation	5	5	2
Lower Respiratory			
Viral respiratory infections	7	4	4
Cough	5	2	2
Musculoskeletal			
Musculoskeletal pain	5	5	4

*This table includes all adverse events (whether considered by the investigator to be drug-related or unrelated to drug) that occurred at an incidence rate of at least 3% in the group treated with VENTOLIN HFA and more frequently in the group treated with VENTOLIN HFA than in the HFA-134a placebo inhaler group.

Overall, the incidence and nature of the adverse events reported for VENTOLIN HFA and VENTOLIN inhalation aerosol (CFC formulation) were similar. Results in a 2-week pediatric clinical study (n=35) showed that the adverse event profile was generally similar to that of the adult.

Adverse events reported by less than 3% of the adolescent and adult patients receiving VENTOLIN HFA and by a greater proportion of patients receiving VENTOLIN HFA than receiving HFA-134a placebo inhaler and that have the potential to be related to VENTOLIN HFA include diarrhea, laryngitis, cough, lung disorders, tachycardia, and extrasystoles. Palpitation and dizziness have also been observed with VENTOLIN HFA.

DRUG INTERACTIONS

Drug-Drug Interactions

Table 2 **Established or Potential Drug-Drug Interactions**

Drug type	Ref	Effect	Clinical comment
Monoamine oxidase inhibitors or tricyclic antidepressants	CS	May potentiate action of salbutamol on cardiovascular system.	Salbutamol should be administered with extreme caution to patients being treated with monoamine oxidase inhibitors or tricyclic antidepressants.
Other inhaled sympathomimetic bronchodilators or epinephrine	CS	May lead to deleterious cardiovascular effects.	Other inhaled sympathomimetic bronchodilators or epinephrine should not be used concomitantly with salbutamol. If additional adrenergic drugs are to be administered by any route to the patient using inhaled salbutamol, the adrenergic drugs should be used with caution. Such concomitant use must be individualised and not given on a routine basis. If regular co-administration is required then alternative therapy must be considered.
Beta-blockers	CS	May effectively antagonize the action of salbutamol.	Beta-adrenergic blocking drugs, especially the non-cardioselective ones, such as propranolol, should not usually be prescribed together.
Diuretics	CS	May lead to ECG changes and/or hypokalemia although the clinical significance of these effects is not known.	The ECG changes and/or hypokalemia that may result from the administration of non-potassium sparing diuretics (such as loop or thiazide diuretics) can be acutely worsened by beta-agonists, especially when the recommended dose of the beta-agonist is exceeded. Caution is advised in the co-administration of beta-agonists with non-potassium sparing diuretics.
Digoxin	CS	May lead to a decrease in serum digoxin levels, although the clinical significance of these findings for patients with obstructive airways disease who are receiving salbutamol and digoxin on a chronic basis is unclear.	Mean decreases of 16-22% in serum digoxin levels were demonstrated after single dose intravenous and oral administration of salbutamol, respectively, to normal volunteers who had received digoxin for 10 days. It would be prudent to carefully evaluate serum digoxin levels in patients who are currently receiving digoxin and salbutamol.

Legend: CS = Class Statement

DOSAGE AND ADMINISTRATION

Dosing Considerations

The dosage should be individualised, and the patient's response should be monitored by the prescribing physician on an ongoing basis.

Increasing demand for VENTOLIN HFA in bronchial asthma is usually a sign of poorly controlled or worsening asthma and indicates that the patient should be re-evaluated, the treatment plan should be reviewed and the regular asthma controller treatment should be optimized. If inhaled salbutamol treatment alone is not adequate to control asthma, concomitant anti-inflammatory therapy should be part of the treatment regimen.

If a previously effective dose fails to provide the usual relief, or the effects of a dose last for less than three hours, patients should seek prompt medical advice since this is usually a sign of worsening asthma.

As there may be adverse effects associated with excessive dosing, the dosage or frequency of administration should only be increased on medical advice. However, if a more severe attack has not been relieved by the usual dose, additional doses may be required. In these cases, patients should immediately consult their doctors or the nearest hospital.

Recommended Dose and Dosage Adjustment

	Relief of Acute Episodes of Bronchospasm*	Prevention of Bronchospasm**	Prevention of Exercise-induced Bronchospasm	Maximum Daily Dose (Total daily dose should not exceed)
Adults and Adolescents (≥ 12 years)	One to two puffs [100 to 200 mcg salbutamol] as needed.	One to two puffs [100 to 200 mcg salbutamol] every 4 to 6 hours to a maximum of four times per day.	Two puffs [200 mcg salbutamol] 15 minutes before exercise.	Eight puffs [800 mcg salbutamol].
Children (4 to < 12 years)	One puff [100 mcg salbutamol] as needed. May be increased to two puffs (200 mcg salbutamol), if required.	One puff [100 mcg salbutamol] every 4 to 6 hours to a maximum of four times per day.	One puff [100 mcg salbutamol] 15 minutes before exercise. May be increased to two puffs (200 mcg salbutamol), if required.	Four puffs [400 mcg salbutamol].

* If a more severe attack has not been relieved by the usual dose, further inhalations may be needed every 4 to 6 hours. More frequent or a larger number of inhalations is not recommended. In these cases, patients should immediately consult their doctors or the nearest hospital.

**Despite appropriate maintenance therapy, regular use of the VENTOLIN HFA remains necessary for the control of bronchospasm due to bronchial asthma.

Missed Dose

If a single dose is missed, instruct the patient to take the next dose when it is due or if they become wheezy.

Administration

VENTOLIN HFA is administered by the inhaled route only. To ensure administration of the proper dose of the drug, the patient should be instructed by the physician or other health professional in the proper use of the inhalation aerosol.

Inhaler actuation should be synchronised with inspiration to ensure optimum delivery of drug to the lungs. In patients who find coordination of a pressurised metered dose inhaler difficult, a spacer may be used with VENTOLIN HFA.

The use of open mouth technique to administer VENTOLIN HFA has not been investigated in clinical trials.

Priming: It is recommended to test spray VENTOLIN HFA into the air four times, away from the face, before using for the first time and in cases where the aerosol has not been used for more than 5 days.

OVERDOSAGE

For management of a suspected drug overdose, contact your regional Poison Control Centre.

Symptoms and signs

The most common signs and symptoms of overdose with salbutamol are transient beta agonist pharmacologically mediated events (see Warning and Precautions and Adverse Reactions). Overdosage may cause tachycardia, cardiac arrhythmia, hypokalemia, hypertension and, in extreme cases, sudden death. Serum potassium levels should be monitored.

Lactic acidosis has been reported in association with high therapeutic doses as well as overdoses of short-acting beta-agonist therapy, therefore monitoring for elevated serum lactate and consequent metabolic acidosis (particularly if there is persistence or worsening of tachypnea despite resolution of other signs of bronchospasm such as wheezing) may be indicated in the setting of overdose.

Treatment

Consideration should be given to discontinuation of treatment and appropriate symptomatic therapy. To antagonise the effect of salbutamol, the judicious use of a cardioselective beta-adrenergic blocking agent (e.g. metoprolol, atenolol) may be considered, bearing in mind the danger of inducing an asthmatic attack. There is insufficient evidence to determine if dialysis is beneficial for overdose of VENTOLIN HFA (salbutamol sulfate) inhalation aerosol.

ACTION AND CLINICAL PHARMACOLOGY

Mechanism of Action

Salbutamol produces bronchodilation through stimulation of beta₂-adrenergic receptors in bronchial smooth muscle, thereby causing relaxation of bronchial muscle fibres. This action is manifested by an improvement in pulmonary function as demonstrated by spirometric measurements. Although beta₂-receptors are the predominant adrenergic receptors in bronchial smooth muscle and beta₁-receptors are the predominant receptors in the heart, there are also beta₂-receptors in the human heart comprising 10% to 50% of the total beta-adrenergic receptors. The precise function of these receptors has not been established, but they raise the possibility that even highly selective beta₂-agonists may have cardiac effects. At therapeutic doses, salbutamol has little action on the beta₁-adrenergic receptors in cardiac muscle.

A measurable decrease in airway resistance is typically observed within 5 to 15 minutes after inhalation of salbutamol. The maximum improvement in pulmonary function usually occurs 60 to 90 minutes after salbutamol treatment, and significant bronchodilator activity has been observed to persist for 3 to 6 hours.

Pharmacokinetics

After inhalation of recommended doses of salbutamol, plasma drug levels are very low. When 100 mcg of tritiated salbutamol aerosol was administered to two normal volunteers, plasma levels of drug-radioactivity were insignificant at 10, 20 and 30 minutes following inhalation. The plasma concentration of salbutamol may be even less as the amount of plasma drug-radioactivity does not differentiate salbutamol from its principal metabolite, a sulfate ester. In a separate study, plasma salbutamol levels ranged from less than 0.5 ng/mL to 1.6 ng/mL in ten asthmatic children one hour after inhalation of 200 micrograms of salbutamol.

Approximately 10% of an inhaled salbutamol dose is deposited in the lungs. Eighty-five per cent of the remaining salbutamol administered from a metered-dose inhaler is swallowed, however, since the dose is low (100 to 200 mcg), the absolute amount swallowed is too small to be of clinical significance. Salbutamol is only weakly bound to plasma proteins. Results of animal studies indicate that following systemic administration, salbutamol does not cross the blood-brain barrier but does cross the placenta using an in vitro perfused isolated human placenta model. It has been found that between 2% and 3% of salbutamol was transferred from the maternal side to the fetal side of the placenta.

Salbutamol is metabolized in the liver. The principal metabolite in humans is salbutamol-o-sulfate, which has negligible pharmacologic activity. Salbutamol may also be metabolized by oxidative deamination and/or conjugation with glucuronide.

Salbutamol is longer acting than isoprenaline in most patients by any route of administration because it is not a substrate for the cellular uptake processes for catecholamines nor for catechol-O-methyl transferase. Salbutamol and its metabolites are excreted in the urine (>80%) and the feces (5% to 10%). Plasma levels are insignificant after administration of aerosolized salbutamol; the plasma half-life ranges from 3.8 to 7.1 hours.

Propellant HFA-134a is devoid of pharmacological activity except at very high doses in animals (140 to 800 times the maximum human exposure based on comparisons of AUC values), primarily producing ataxia, tremors, dyspnea, or salivation. These are similar to effects produced by the structurally related CFCs, which have been used extensively in metered-dose inhalers.

In animals and humans, propellant HFA-134a was eliminated rapidly in the breath, with no evidence of metabolism or accumulation in the body. Time to maximum plasma concentration (t_{max}) and mean residence time are both extremely short, leading to a transient appearance of HFA-134a in the blood with no evidence of accumulation.

STORAGE AND STABILITY

Replace the mouthpiece cover firmly and snap it into position. Keep out of the sight and reach of children. Store at a temperature between 15°C and 25°C.

SPECIAL HANDLING INSTRUCTIONS

The contents of VENTOLIN HFA (salbutamol sulfate) inhalation aerosol are under pressure. The container may explode if heated. Do not place in hot water or near radiators, stoves or other sources of heat. Even when empty, do not puncture or incinerate container. As with most inhaled medications in aerosol canisters, the therapeutic effect of this medication may decrease when the canister is cold.

DOSAGE FORMS, COMPOSITION AND PACKAGING

VENTOLIN HFA (salbutamol sulfate) inhalation aerosol is a pressurized metered dose inhaler (MDI) consisting of an aluminum canister fitted with a metering valve. Each canister is fitted into the supplied blue plastic actuator. A blue dust cap is fitted over the actuator's mouthpiece when not in use. Each depression of the valve delivers 100 mcg of salbutamol (as sulfate).

VENTOLIN HFA contains a micro-crystalline suspension of salbutamol sulfate in propellant HFA-134a (1,1,1,2-tetrafluoroethane). It contains no excipients. Each actuation delivers 100 micrograms of salbutamol (as sulfate). This product does not contain chlorofluorocarbons (CFCs) as the propellant.

VENTOLIN HFA is available in 200 dose formats.

PART II: SCIENTIFIC INFORMATION

PHARMACEUTICAL INFORMATION

Drug Substance

Proper name: salbutamol sulfate

Chemical name: α^1 -[(*tert*-butylamino)methyl]-4-hydroxy-*m*-xylene- α, α' -diol sulfate (2:1) (salt)

Molecular formula and molecular mass: $(C_{13}H_{21}NO_3)_2XH_2SO_4$ 576.7

Structural formula:

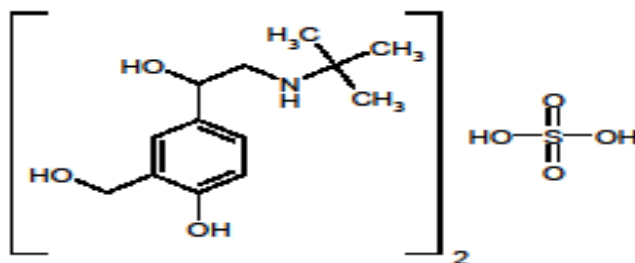

Physicochemical properties:

<i>Description</i>	White to almost white powder.
<i>Solubility</i>	Soluble in water and slightly soluble in methanol.
<i>pKa Values</i>	9.4 and 10.0.
<i>Distribution Coefficient</i>	The distribution coefficient between two phases of octanol and water, as determined by HPLC, at pH 9.9 is 0.23.
<i>Melting Point</i>	Approximately 156°C.

CLINICAL TRIALS

In two 12-week, randomized, double-blind studies, VENTOLIN HFA (salbutamol sulfate) inhalation aerosol (202 patients) was compared to VENTOLIN inhalation aerosol (CFC formulation) (207 patients) and an HFA-134a placebo inhaler (201 patients) in adolescent and adult patients with mild to moderate asthma. The studies were similar in design.

One study evaluated the safety and efficacy of VENTOLIN HFA in patients with asthma, and the second study evaluated the effects of switching from VENTOLIN inhalation aerosol (CFC formulation) to VENTOLIN HFA. Serial forced expiratory volume in 1 second (FEV₁) measurements (shown below as percent change from test-day baseline at week 12, n = 525) demonstrated that two inhalations of VENTOLIN HFA produced significantly greater improvement in pulmonary function than placebo and produced outcomes that were clinically comparable to VENTOLIN inhalation aerosol (CFC formulation). Patients taking the HFA-134a placebo inhaler also took VENTOLIN HFA for asthma symptom relief on an as-needed basis. These patients produced similar morning predose baseline FEV₁ values to patients taking VENTOLIN HFA and VENTOLIN inhalation aerosol (CFC formulation) taken four times daily (plus as-needed for asthma symptom relief) throughout the 12-week study period.

FEV₁ as Percent Change From Predose in Two Large, 12-Week Clinical Trials

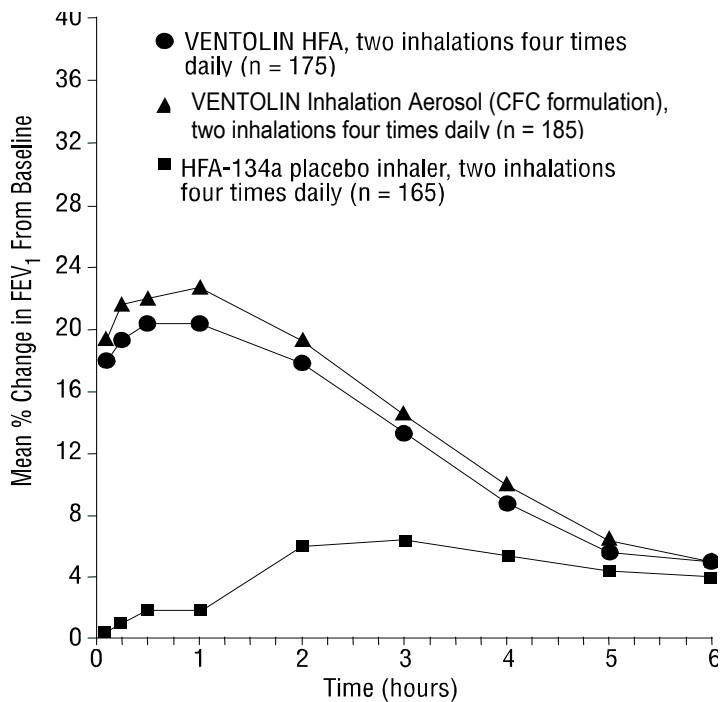

The median time to onset of a 15% increase in FEV₁ was 4.8 minutes, and the median time to peak effect was 48 to 60 minutes. The mean duration of effect as measured by a 15% increase in FEV₁ was approximately 3 hours. In some patients, duration of effect was as long as 6 hours.

In a 2-week, randomized, double-blind study, VENTOLIN HFA was compared to VENTOLIN inhalation aerosol (CFC formulation) and an HFA-134a placebo inhaler in 135 pediatric patients (4 to 11 years old) with mild to moderate asthma. Serial pulmonary function measurements demonstrated that two inhalations of VENTOLIN HFA produced significantly greater improvement in pulmonary function than placebo and that there were no significant differences between the groups treated with VENTOLIN HFA and VENTOLIN inhalation aerosol (CFC formulation).

The median time to onset of a 15% increase in peak expiratory flow rate (PEFR) was 5 to 10 minutes, and the median time to peak effect was approximately 60 minutes. The mean duration of effect as measured by a 15% increase in PEFR was 2.5 hours. In some patients, duration of effect was as long as 6 hours.

In a clinical study in adult patients with asthma, two inhalations of VENTOLIN HFA taken approximately 30 minutes prior to exercise significantly prevented exercise-induced bronchospasm (as measured by maximum percentage fall in FEV₁ following exercise) compared to an HFA-134a placebo inhaler. In addition, VENTOLIN HFA was shown to be clinically comparable to VENTOLIN inhalation aerosol (CFC formulation).

DETAILED PHARMACOLOGY

Animals

In vitro studies and *in vivo* pharmacologic studies have demonstrated that salbutamol has a preferential effect on beta₂-adrenergic receptors compared with isoprenaline. While it is recognized that beta₂-adrenergic receptors are the predominant receptors in bronchial smooth muscle, recent data indicate that there is a population of beta₂-receptors in the human heart existing in a concentration between 10% and 50%. The precise function of these, however, is not yet established.

The pharmacologic effects of beta-adrenergic agonist drugs, including salbutamol, are at least in part attributable to stimulation through beta-adrenergic receptors of intracellular adenylyl cyclase, the enzyme that catalyzes the conversion of adenosine triphosphate (ATP) to cyclic-3',5'-adenosine monophosphate (cAMP). Increased cAMP levels are associated with relaxation of bronchial smooth muscle and inhibition of release of mediators of immediate hypersensitivity from cells, especially from mast cells.

The muscle-relaxing effect of salbutamol was found to be more prolonged than when the effect was induced by isoprenaline. As suggested from the results of experiments in isolated animal tissues, salbutamol has been shown to produce a substantial bronchodilator effect in the intact animal. In the anaesthetised guinea pig, salbutamol

completely prevents acetylcholine-induced bronchospasm at the dose of 100 micrograms/kg intravenously.

Administration of salbutamol aerosol at a dose of 250 micrograms/mL for one minute to guinea pigs prevented acetylcholine-induced bronchospasm without any chronotropic effect. A prolonged bronchodilator effect of salbutamol compared to isoprenaline (in terms of mean times to dyspnea following acetylcholine challenge) was observed following oral administration of salbutamol to conscious guinea pigs. The protective action of salbutamol in this case persisted for up to six hours.

In anaesthetised cats and dogs, salbutamol prevented the bronchospasm elicited by vagal stimulation without any significant effect on heart rate and blood pressure. Comparative tests of salbutamol and isoprenaline in isolated dog papillary muscle, guinea pig atrial muscle and human heart muscle have shown that the effect of salbutamol on beta₁-adrenergic receptors in the heart is minimal.

In a number of studies using guinea pig atria, it was found that on a weight-to-weight basis, salbutamol was from 2,000 to 2,500 times less active in terms of inotropic effect and 500 times less active in terms of chronotropic effect than isoprenaline. Compared to orciprenaline, salbutamol was about 40 times less active in terms of inotropic effect and four times less potent in terms of chronotropic effect. Salbutamol has been shown to be one-fifth as potent a vasodilator in skeletal muscle as isoprenaline, as measured by effects on hind limb blood flow in the anaesthetised dog. In the perfused rabbit ear, salbutamol was shown to possess only one-tenth the activity of isoprenaline in terms of vasodilating effect. In dogs, salbutamol was shown to increase coronary blood flow, which was subsequently shown to be the result of a direct coronary vasodilating effect of salbutamol.

In six dogs with right-sided cardiac by-pass, salbutamol, given at the dose of 25 micrograms/kg, improved left ventricular efficiency and increased coronary blood flow. Recent studies in minipigs, rodents, and dogs recorded the occurrence of cardiac arrhythmias and sudden death (with histologic evidence of myocardial necrosis) when beta-agonists and methylxanthines were administered concurrently. The significance of these findings when applied to humans is currently unknown.

Animal studies show that salbutamol does not pass the blood brain barrier.

TOXICOLOGY

Acute Toxicity

Species (n)	Oral LD ₅₀	Intravenous LD ₅₀
Mouse (10)	>2000 mg/kg	72 mg/kg
Rat (10)	>2000 mg/kg	60 mg/kg

Rat (n)	Intraperitoneal LD ₅₀
Newborn (155)	216 mg/kg
Weanling (100)	524 mg/kg
2 week old (90)	437 mg/kg

The rate of respiration in test animals initially increased, but subsequently became abnormally slow and deep. Death, preceded by convulsions and cyanosis, usually occurred within four hours after drug administration.

Rabbits, cats and dogs survived a single dose of 50 mg/kg salbutamol.

Intermediate (Four Months) Toxicity

Rats received salbutamol twice daily, in oral doses from 0.5 to 25 mg/kg, on an increasing scale. The only significant hematological changes were a small increase in hemoglobin and packed cell volume. BUN and SGOT values were elevated while blood glucose and plasma protein levels remained unchanged. Pituitaries had increased amount of PAS-positive material in the cleft at the higher dose levels.

Salbutamol was given to dogs twice daily, in oral doses from 0.05 to 12.5 mg/kg, on an increasing scale. The rate of increase of hemoglobin and packed cell volume was depressed, particularly at higher doses. Leukocyte count decreased after sixteen weeks of treatment at each dose level. Platelet count was increased after eight weeks at the highest dose. No significant biochemical effects were observed. The only significant histological change was the appearance of corpora amylacea in the stomach which was attributed to altered mucus secretion. Inhalation of 1000 mcg of salbutamol CFC 11/12-propelled aerosol twice daily for three months did not produce any morphological changes in the lungs, trachea, lymph nodes, liver or heart.

Long-Term Toxicity

Fifty female, Charles River CD Albino rats received salbutamol orally at 2, 10 and 50 mg/kg/day for one hundred and four weeks; fifty female Charles River CD Sprague-Dawley-derived rats received 20 mg/kg/day salbutamol orally for fifty weeks, and fifty female Charles River Long-Evans rats received 20 mg/kg/day salbutamol orally for ninety-six weeks. These rat studies demonstrated a dose-related incidence of mesovarian leiomyomas. No similar tumors were seen in mice.

Mutagenicity

In vitro tests involving four micro-organisms revealed no mutagenic activity.

Carcinogenicity

In a two-year study in the rat, salbutamol sulfate caused a significant dose-related increase in the incidence of benign leiomyomas of the mesovarium at doses corresponding to 111, 555, and 2,800 times the maximum human inhalation dose. In another study, the effect was blocked by the co-administration of propranolol. The relevance of these findings to humans is not known. An 18-month study in mice and a lifetime study in hamsters revealed no evidence of tumorigenicity.

Teratogenicity Studies

Salbutamol has been shown to be teratogenic in mice when given in doses corresponding to 14 times the human aerosol dose; when given subcutaneously in doses corresponding to 0.2 times the maximum human (child weighing 21 kg) oral dose; and when given subcutaneously in doses corresponding to 0.4 times the maximum human oral dose.

A reproduction study in CD-1 mice given salbutamol at doses of 0.025, 0.25, and 2.5 mg/kg subcutaneously, corresponding to 1.4, 14, and 140 times the maximum human aerosol dose respectively, showed cleft palate formation in 5 of 111 (4.5%) fetuses at 0.25 mg/kg and in 10 of 108 (9.3%) fetuses at 2.5 mg/kg. No cleft palates were observed at a dose of 0.025 mg/kg salbutamol. Cleft palate occurred in 22 of 72 (30.5%) fetuses treated with 2.5 mg/kg isoprenaline (positive control).

In rats, salbutamol treatment given orally at 0.5, 2.32, 10.75 and 50 mg/kg/day throughout pregnancy resulted in no significant fetal abnormalities. However, at the highest dose level there was an increase in neonatal mortality. Reproduction studies in rats revealed no evidence of impaired fertility.

Salbutamol had no adverse effect when given orally to Stride Dutch rabbits, at doses of 0.5, 2.32 and 10.75 mg/kg/day throughout pregnancy. At a dose of 50 mg/kg/day, which represents 2800 times the maximum human inhalation dose, cranioschisis was observed in 7 of 19 (37%) fetuses.

A reproduction study in New Zealand White rabbits using salbutamol sulfate/HFA-134a formulation, revealed enlargement of the frontal portion of the fontanelles in 6 of 95 (6%) and 15 of 107 (14%) fetuses at 28 and 149 mcg/kg, respectively (approximately 2/5 and 2 times, respectively, the maximum recommended human daily dose on a mg/m² basis), giving plasma levels of approximately 12 and 60 ng/mL, respectively.

PART III: CONSUMER INFORMATION**Pr VENTOLIN HFA****salbutamol sulfate inhalation aerosol**

This leaflet is part III of a three-part "Product Monograph" for VENTOLIN HFA and is designed specifically for Consumers. This leaflet is a summary and will not tell you everything about VENTOLIN HFA. Contact your doctor or pharmacist if you have any questions about the drug. Only a doctor can prescribe it for you. Never give it to someone else. It may harm them even if their symptoms are the same as yours.

ABOUT THIS MEDICATION**What the medication is used for:**

VENTOLIN HFA is used in Adults and Children 4 years or older to:

- relieve bronchospasm
- prevent bronchospasm
- prevent bronchospasm caused by exercise

Bronchospasm is a sudden worsening of shortness of breath and wheezing.

The safety and effectiveness of VENTOLIN HFA in children under the age of 4 are not known.

What it does:

Salbutamol is one of a group of medicines called bronchodilators. Salbutamol relaxes the muscles in the walls of the small air passages in the lungs. This helps to open up the airways and so helps to relieve chest tightness, wheezing and cough so that you can breathe more easily.

When it should not be used:

Do not use VENTOLIN HFA if you are allergic to it or any of the components of its formulation or for the treatment of preterm labour or miscarriage.

What the medicinal ingredient is:

Salbutamol sulfate.

What the nonmedicinal ingredient is:

1, 1, 1, 2-tetrafluoroethane (HFA-134a).

What dosage forms it comes in:

VENTOLIN HFA is a pressurized metered dose inhaler containing 100 mcg of salbutamol per inhalation. VENTOLIN HFA will deliver at least 200 puffs. However, after 200 puffs, the amount of drug delivered per spray may not be consistent. The canister should be discarded when 200 puffs have been used.

WARNINGS AND PRECAUTIONS

Before you use VENTOLIN HFA, talk to your doctor or pharmacist if:

- You have ever had to stop taking other medications for this illness because you were allergic to them or they caused problems.
- You are having treatment for a thyroid condition.
- You are having treatment for high blood pressure or a heart problem.
- You have diabetes.
- You have a past history of seizures.
- You have low levels of potassium in your blood (hypokalemia), especially if you are taking:
 - Drugs known as xanthine derivatives (such as theophylline)
 - steroids to treat asthma
 - Water pills (diuretics)
- You are pregnant or intend to become pregnant. Taking VENTOLIN HFA during pregnancy may cause harm to your baby. Your doctor will consider the benefit to you and the risk to your baby of taking VENTOLIN HFA while you're pregnant.
- You are breastfeeding. It is not known if VENTOLIN HFA passes into breast milk.

If the relief of wheezing or chest tightness is not as good as usual, or the effect lasts for less than three hours, tell your doctor as soon as possible. If you notice a sudden worsening of your shortness of breath and wheeze shortly after taking your medicine, tell your doctor as soon as possible. It may be that your chest condition is worsening and you may need to add another type of medicine to your treatment.

You should always carry your VENTOLIN HFA with you to use immediately in case you experience an asthma attack.

Effects on Children:

Children may experience:

- Changes in sleep patterns
- changes in behaviour such as restlessness, excitability (hyperactivity)
- seeing or hearing things that are not there

INTERACTIONS WITH THIS MEDICATION

As with most medicines, interactions with other drugs are possible. Tell your doctor, nurse, or pharmacist about all the medicines you take, including drugs prescribed by other doctors, vitamins, minerals, natural supplements, or alternative medicines.

The following may interact with VENTOLIN HFA:

- Anti-depressants
- Allergy medication
- Blood pressure-lowering drugs, including propranolol
- Diuretics (“water pills”)
- Bronchodilators used to open the airway (such as other asthma medication)
- Epinephrine
- Digoxin, a heart medication

PROPER USE OF THIS MEDICATION

VENTOLIN HFA **should only be inhaled**. Do not swallow.

If You Are Also Using an Inhaled Corticosteroid:

- Always use VENTOLIN HFA first
- Wait a few minutes
- Then use your inhaled corticosteroid.

Your doctor may prescribe VENTOLIN HFA regularly every day, or only for when you are wheezy or short of breath, or before you exercise. Use VENTOLIN HFA only as directed by your doctor.

The action of VENTOLIN HFA may last up to 6 hours and should last for at least 4 hours.

You should call your doctor immediately if:

- the effects of one dose last less than 3 hours;
- you notice a sudden worsening of your shortness of breath
- your symptoms gets worse;
- your usual dose does not provide relief of wheezing or chest tightness;
- you need to use VENTOLIN HFA more often than before

These may be signs that your asthma or chest condition is getting worse. Your doctor may want to reassess your treatment plan.

Do not increase the dose or the number of times you use your medicine without asking your doctor, as this may make you feel worse.

If you have to go into hospital for an operation, take your inhaler with you and tell the doctor what medicine(s) you are taking.

If your doctor decides to stop your treatment, do not keep any left over medicine unless your doctor tells you to.

Usual dose:

Adults and Adolescents 12 years or older

- **To relieve bronchospasm:** 1 to 2 puffs as needed. If you have a more severe attack, you can repeat the dose every 4 to 6 hours, and immediately consult your doctor or the nearest hospital.
- **To prevent bronchospasm:** 1 to 2 puffs repeated every 4 to 6 hours to a maximum four times a day.
- **To prevent bronchospasm caused by exercise:** 2 puffs 15 minutes before exercise.

Maximum dose – 8 puffs in a 24 hour period

Children 4-11 years

- **To relieve bronchospasm:** 1 puff as needed. The dose may be increased to 2 puffs if required. Follow your doctor’s instructions. If you have a more severe attack you can repeat the dose every 4 to 6 hours, and immediately consult your doctor or the nearest hospital.
- **To prevent bronchospasm:** 1 puff repeated every 4 to 6 hours to a maximum four times a day as prescribed by your doctor.
- **To prevent bronchospasm caused by exercise:** 1 puff 15 minutes before exercise. The dose may be increased to 2 puffs if required. Follow your doctor’s instructions.

Maximum dose – 4 puffs in a 24 hour period

How to Prime VENTOLIN HFA:

Before using VENTOLIN HFA for the first time, or if your inhaler has not been used for more than 5 days, shake the inhaler well and release four puffs into the air to ensure that it works properly.

How to Use VENTOLIN HFA:

It is extremely important that you use your VENTOLIN HFA properly. This will ensure it is delivered correctly so that you receive maximum benefit. Carefully follow the instructions shown.

1. To remove the snap-on mouthpiece cover, hold between the thumb and forefinger, squeeze gently and pull apart as shown. Check inside and outside of the inhaler including the mouthpiece for the presence of loose objects.
2. Shake the inhaler well to ensure that any loose objects are removed and the contents of the inhaler are evenly mixed.

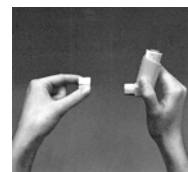

3. Hold the inhaler upright between fingers and thumb with your thumb on the base, below the mouthpiece. Breathe out as far as is comfortable.



4. Place the mouthpiece in your mouth between your teeth and close your lips around it, but do not bite it. Just after starting to breathe in through your mouth, press down on the top of the inhaler to release the drug while still breathing in steadily and deeply.



5. While holding your breath, take the inhaler from your mouth and take your finger from the top of the inhaler. Continue holding your breath for as long as is comfortable.



6. If you are to take further puffs, keep the inhaler upright and wait about half a minute before repeating steps 2 through 5.
7. Replace the mouthpiece cover by firmly pushing and snapping the cap into position to keep out dust and lint.

Important: Do not rush steps 3, 4, and 5. It is important that you start to breathe in as slowly as possible just before operating your inhaler. Practice in front of a mirror for the first few times. If you see "mist" coming from the top of your inhaler or the sides of your mouth, you should start again from step 2.

Children - VENTOLIN HFA should be used under the supervision of an adult who understands the proper use of the inhaler, and only as prescribed by the doctor. The adult must encourage the child (as described above) to exhale, and then trigger the spray immediately as inhalation begins. Use of a spacer with the inhaler is recommended for children under 5 years of age. Talk to your doctor if your child has difficulties using the inhaler.

How to clean VENTOLIN HFA :

Your inhaler should be cleaned at least once per week.

1. Pull the metal canister out of the plastic casing of the inhaler and remove the mouthpiece cover.
2. Rinse the plastic casing of the inhaler thoroughly under warm running water and then wash the plastic casing again through the mouthpiece. **Do not put the metal canister into water.**
3. Dry the plastic casing of the inhaler THOROUGHLY inside and out.
4. Replace the canister and mouthpiece cover.
5. After cleansing, release one puff into the air to make sure that the inhaler works.

Overdose:

In case of drug overdose, contact a health care practitioner, hospital emergency department or regional Poison Control Centre immediately, even if there are no symptoms. Take this leaflet or your medication with you so that the hospital or poison control centre will know what you have taken.

If you accidentally take a **larger dose than prescribed**, you are more likely to get side effects like a faster heart beat, headaches and feeling shaky or restless. These effects usually wear off within a few hours, but you should tell your doctor as soon as possible.

Missed Dose:

If you forget to inhale a dose, do not worry, just inhale the next dose when it is due or if you become wheezy.

SIDE EFFECTS AND WHAT TO DO ABOUT THEM

Side effects may include:

Effects on heart

- Hypertension

Effects on nervous system

- Headache
- Feeling a little shaky
- Feeling anxious or irritable
- Feeling tired or weak
- Trouble sleeping (insomnia)
- Hyperactivity in children
- Dizziness, vertigo
- Drowsiness

Effects on muscles and joints

- Muscle cramps
- Muscle pain

Other Effects

- Cough
- Respiratory infections and/or inflammation
- Diarrhea
- Nausea and vomiting
- Chest pain or discomfort
- Flushing
- Difficulty urinating
- Unusual taste in your mouth
- Dry or irritated throat

SERIOUS SIDE EFFECTS, HOW OFTEN THEY HAPPEN AND WHAT TO DO ABOUT THEM

Symptom/effect		Talk with your doctor or pharmacist		Stop taking drug and call your doctor or pharmacist
		Only if severe	In all cases	
Common	Faster heart beat than usual		✓	
Uncommon	Irregular heart beat (palpitations)		✓	
Rare	Low Blood Potassium (hypokalemia): muscle weakness and muscle spasms		✓	
	Hallucinations in Children: see or hear things that are not there		✓	
Very Rare	Bronchospasm: Sudden worsening of shortness of breath and wheezing shortly after using VENTOLIN HFA			✓
	Allergic Reactions: sudden wheeziness and chest pain or tightness; or swelling of eyelids, face, lips, tongue or throat.			✓
	Irregular Heart Beat (atrial fibrillation, supraventricular tachycardia, extrasystoles)		✓	

This is not a complete list of side effects. If you have any unexpected effects after receiving VENTOLIN HFA, contact your doctor or pharmacist.

HOW TO STORE IT

Keep out of sight and reach of children.

After use, replace the mouthpiece cover firmly and snap it into position. Do not use excessive force.

Store at a temperature between 15°C and 25°C. Do not keep any left over medicine unless your doctor tells you to.

Warning: The canister contents are under pressure. The canister may explode if heated. Do not place in hot water or near radiators, stoves or other sources of heat. Even when empty, do not puncture or incinerate canister.

REPORTING SUSPECTED SIDE EFFECTS

You can report any suspected adverse reactions associated with the use of health products to the Canada Vigilance Program by one of the following 3 ways:

- Report online at <https://www.canada.ca/en/health-canada/services/drugs-health-products/medeffect-canada/adverse-reaction-reporting.html>
- Call toll-free at 1-866-234-2345
- Complete a Canada Vigilance Reporting Form and:
 - Fax toll-free to 1-866-678-6789, or
 - Mail to: Canada Vigilance Program
Health Canada
Postal Locator 1908C
Ottawa, Ontario
K1A 0K9

Postage paid labels, Canada Vigilance Reporting Form and the adverse reaction reporting guidelines are available on the MedEffect™ Canada Web site at <https://www.canada.ca/en/health-canada/services/drugs-health-products/medeffect-canada/adverse-reaction-reporting.html>.

NOTE: Should you require information related to the management of side effects, contact your health professional. The Canada Vigilance Program does not provide medical advice.

MORE INFORMATION

You may need to read this leaflet again. **PLEASE DO NOT THROW IT AWAY** until you have finished your medicine.

This document plus the full product monograph, prepared for health professionals, can be found at:

<http://www.gsk.ca>;

Or by contacting the sponsor,
GlaxoSmithKline Inc.
7333 Mississauga Road
Mississauga, Ontario
L5N 6L4
1-800-387-7374.

This leaflet was prepared by GlaxoSmithKline Inc.

Last revised: November 17, 2017

© 2017 GSK group of companies or its licensor. Trademarks are owned by or licensed to the GSK group of companies.

HIGHLIGHTS OF PRESCRIBING INFORMATION

These highlights do not include all the information needed to use VENTOLIN HFA safely and effectively. See full prescribing information for VENTOLIN HFA.

VENTOLIN HFA (albuterol sulfate) Inhalation Aerosol, for oral inhalation use

Initial U.S. Approval: 1981

INDICATIONS AND USAGE

VENTOLIN HFA is a beta₂-adrenergic agonist indicated for:

- Treatment or prevention of bronchospasm in patients aged 4 years and older with reversible obstructive airway disease. (1.1)
- Prevention of exercise-induced bronchospasm in patients aged 4 years and older. (1.2)

DOSAGE AND ADMINISTRATION

- For oral inhalation only. (2)
- Treatment or prevention of bronchospasm in adults and children aged 4 years and older: 2 inhalations every 4 to 6 hours. For some patients, 1 inhalation every 4 hours may be sufficient. (2.1)
- Prevention of exercise-induced bronchospasm in adults and children aged 4 years and older: 2 inhalations 15 to 30 minutes before exercise. (2.2)
- Priming information: Prime VENTOLIN HFA before using for the first time, when the inhaler has not been used for more than 2 weeks, or when the inhaler has been dropped. To prime VENTOLIN HFA, release 4 sprays into the air away from the face, shaking well before each spray. (2.3)
- Cleaning information: At least once a week, wash the actuator with warm water and let it air-dry completely. (2.3)

DOSAGE FORMS AND STRENGTHS

Inhalation aerosol: Inhaler containing 108 mcg albuterol sulfate (90 mcg albuterol base) as an aerosol formulation for oral inhalation. (3)

CONTRAINDICATIONS

Hypersensitivity to any ingredient. (4)

WARNINGS AND PRECAUTIONS

- Life-threatening paradoxical bronchospasm may occur. Discontinue VENTOLIN HFA immediately and institute alternative therapy. (5.1)
- Need for more doses of VENTOLIN HFA than usual may be a sign of deterioration of asthma and requires reevaluation of treatment. (5.2)
- VENTOLIN HFA is not a substitute for corticosteroids. (5.3)
- Cardiovascular effects may occur. Use with caution in patients sensitive to sympathomimetic drugs and patients with cardiovascular or convulsive disorders. (5.4, 5.7)
- Excessive use may be fatal. Do not exceed recommended dose. (5.5)
- Immediate hypersensitivity reactions may occur. Discontinue VENTOLIN HFA immediately. (5.6)
- Hypokalemia and changes in blood glucose may occur. (5.7, 5.8)

ADVERSE REACTIONS

Most common adverse reactions (incidence ≥3%) are throat irritation, viral respiratory infections, upper respiratory inflammation, cough, and musculoskeletal pain. (6.1)

To report SUSPECTED ADVERSE REACTIONS, contact GlaxoSmithKline at 1-888-825-5249 or FDA at 1-800-FDA-1088 or www.fda.gov/medwatch.

DRUG INTERACTIONS

- Beta-blockers: Use with caution. May block bronchodilatory effects of beta-agonists and produce severe bronchospasm. (7.1)
- Diuretics: Use with caution. Electrocardiographic changes and/or hypokalemia associated with non-potassium-sparing diuretics may worsen with concomitant beta-agonists. (7.2)
- Digoxin: May decrease serum digoxin levels. Consider monitoring digoxin levels. (7.3)
- Monoamine oxidase inhibitors and tricyclic antidepressants: Use with extreme caution. May potentiate effect of albuterol on vascular system. (7.4)

See 17 for PATIENT COUNSELING INFORMATION and FDA-approved patient labeling.

Revised: 12/2019

FULL PRESCRIBING INFORMATION: CONTENTS*

1 INDICATIONS AND USAGE

- 1.1 Bronchospasm
- 1.2 Exercise-Induced Bronchospasm

2 DOSAGE AND ADMINISTRATION

- 2.1 Bronchospasm
- 2.2 Exercise-Induced Bronchospasm
- 2.3 Administration Information

3 DOSAGE FORMS AND STRENGTHS

4 CONTRAINDICATIONS

5 WARNINGS AND PRECAUTIONS

- 5.1 Paradoxical Bronchospasm
- 5.2 Deterioration of Asthma
- 5.3 Use of Anti-inflammatory Agents
- 5.4 Cardiovascular Effects
- 5.5 Do Not Exceed Recommended Dose
- 5.6 Immediate Hypersensitivity Reactions
- 5.7 Coexisting Conditions
- 5.8 Hypokalemia

6 ADVERSE REACTIONS

- 6.1 Clinical Trials Experience
- 6.2 Postmarketing Experience

7 DRUG INTERACTIONS

- 7.1 Beta-Adrenergic Receptor Blocking Agents

- 7.2 Non-Potassium-Sparing Diuretics

- 7.3 Digoxin

- 7.4 Monoamine Oxidase Inhibitors and Tricyclic Antidepressants

8 USE IN SPECIFIC POPULATIONS

- 8.1 Pregnancy
- 8.2 Lactation
- 8.4 Pediatric Use
- 8.5 Geriatric Use

10 OVERDOSAGE

11 DESCRIPTION

12 CLINICAL PHARMACOLOGY

- 12.1 Mechanism of Action
- 12.3 Pharmacokinetics

13 NONCLINICAL TOXICOLOGY

- 13.1 Carcinogenesis, Mutagenesis, Impairment of Fertility
- 13.2 Animal Toxicology and/or Pharmacology

14 CLINICAL STUDIES

- 14.1 Bronchospasm Associated with Asthma
- 14.2 Exercise-Induced Bronchospasm

16 HOW SUPPLIED/STORAGE AND HANDLING

17 PATIENT COUNSELING INFORMATION

*Sections or subsections omitted from the full prescribing information are not listed.

FULL PRESCRIBING INFORMATION

1 INDICATIONS AND USAGE

1.1 Bronchospasm

VENTOLIN HFA Inhalation Aerosol is indicated for the treatment or prevention of bronchospasm in patients aged 4 years and older with reversible obstructive airway disease.

1.2 Exercise-Induced Bronchospasm

VENTOLIN HFA is indicated for the prevention of exercise-induced bronchospasm in patients aged 4 years and older.

2 DOSAGE AND ADMINISTRATION

2.1 Bronchospasm

For treatment of acute episodes of bronchospasm or prevention of symptoms associated with bronchospasm, the usual dosage for adults and children is 2 inhalations repeated every 4 to 6 hours; in some patients, 1 inhalation every 4 hours may be sufficient. More frequent administration or a greater number of inhalations is not recommended.

2.2 Exercise-Induced Bronchospasm

For prevention of exercise-induced bronchospasm, the usual dosage for adults and children aged 4 years and older is 2 inhalations 15 to 30 minutes before exercise.

2.3 Administration Information

VENTOLIN HFA should be administered by the orally inhaled route only.

Priming

Priming VENTOLIN HFA is essential to ensure appropriate albuterol content in each actuation. Prime VENTOLIN HFA before using for the first time, when the inhaler has not been used for more than 2 weeks, or when the inhaler has been dropped. To prime VENTOLIN HFA, release 4 sprays into the air away from the face, shaking well before each spray.

Cleaning

To ensure proper dosing and to prevent actuator orifice blockage, wash the actuator with warm water and let it air-dry completely at least once a week.

3 DOSAGE FORMS AND STRENGTHS

Inhalation aerosol: Blue plastic inhaler with a blue strapcap containing a pressurized metered-dose aerosol canister containing 60 or 200 metered inhalations and fitted with a counter. Each actuation delivers 108 mcg of albuterol sulfate (90 mcg of albuterol base) from the

mouthpiece.

4 CONTRAINDICATIONS

VENTOLIN HFA is contraindicated in patients with a history of hypersensitivity to any of the ingredients [*see Warnings and Precautions (5.6), Description (11)*].

5 WARNINGS AND PRECAUTIONS

5.1 Paradoxical Bronchospasm

VENTOLIN HFA can produce paradoxical bronchospasm, which may be life threatening. If paradoxical bronchospasm occurs following dosing with VENTOLIN HFA, it should be discontinued immediately and alternative therapy should be instituted. It should be recognized that paradoxical bronchospasm, when associated with inhaled formulations, frequently occurs with the first use of a new canister.

5.2 Deterioration of Asthma

Asthma may deteriorate acutely over a period of hours or chronically over several days or longer. If the patient needs more doses of VENTOLIN HFA than usual, this may be a marker of destabilization of asthma and requires reevaluation of the patient and treatment regimen, giving special consideration to the possible need for anti-inflammatory treatment, e.g., corticosteroids.

5.3 Use of Anti-inflammatory Agents

The use of beta-adrenergic agonist bronchodilators alone may not be adequate to control asthma in many patients. Early consideration should be given to adding anti-inflammatory agents, e.g., corticosteroids, to the therapeutic regimen.

5.4 Cardiovascular Effects

VENTOLIN HFA, like all other beta₂-adrenergic agonists, can produce clinically significant cardiovascular effects in some patients such as changes in pulse rate or blood pressure. If such effects occur, VENTOLIN HFA may need to be discontinued. In addition, beta-agonists have been reported to produce electrocardiogram (ECG) changes, such as flattening of the T wave, prolongation of the QTc interval, and ST segment depression. The clinical relevance of these findings is unknown. Therefore, VENTOLIN HFA, like all other sympathomimetic amines, should be used with caution in patients with underlying cardiovascular disorders, especially coronary insufficiency, cardiac arrhythmias, and hypertension.

5.5 Do Not Exceed Recommended Dose

Fatalities have been reported in association with excessive use of inhaled sympathomimetic drugs in patients with asthma. The exact cause of death is unknown, but cardiac arrest following an unexpected development of a severe acute asthmatic crisis and subsequent hypoxia is suspected.

5.6 Immediate Hypersensitivity Reactions

Immediate hypersensitivity reactions (e.g., urticaria, angioedema, rash, bronchospasm, hypotension), including anaphylaxis, may occur after administration of VENTOLIN HFA [see *Contraindications (4)*].

5.7 Coexisting Conditions

VENTOLIN HFA, like other sympathomimetic amines, should be used with caution in patients with convulsive disorders, hyperthyroidism, or diabetes mellitus and in patients who are unusually responsive to sympathomimetic amines. Large doses of intravenous albuterol have been reported to aggravate preexisting diabetes mellitus and ketoacidosis.

5.8 Hypokalemia

Beta-adrenergic agonist medicines may produce significant hypokalemia in some patients, possibly through intracellular shunting, which has the potential to produce adverse cardiovascular effects [see *Clinical Pharmacology (12.1)*]. The decrease in serum potassium is usually transient, not requiring supplementation.

6 ADVERSE REACTIONS

Use of VENTOLIN HFA may be associated with the following:

- Paradoxical bronchospasm [see *Warnings and Precautions (5.1)*]
- Cardiovascular effects [see *Warnings and Precautions (5.4)*]
- Immediate hypersensitivity reactions [see *Warnings and Precautions (5.6)*]
- Hypokalemia [see *Warnings and Precautions (5.8)*]

6.1 Clinical Trials Experience

Because clinical trials are conducted under widely varying conditions, adverse reaction rates observed in the clinical trials of a drug cannot be directly compared with rates in the clinical trials of another drug and may not reflect the rates observed in practice.

The safety data described below reflects exposure to VENTOLIN HFA in 248 subjects treated with VENTOLIN HFA in 3 placebo-controlled clinical trials of 2 to 12 weeks' duration. The data from adults and adolescents is based upon 2 clinical trials in which 202 subjects with asthma aged 12 years and older were treated with VENTOLIN HFA 2 inhalations 4 times daily for 12 weeks' duration. The adult/adolescent population was 92 female, 110 male and 163 white, 19 black, 18 Hispanic, 2 other. The data from pediatric subjects are based upon 1 clinical trial in which 46 subjects with asthma aged 4 to 11 years were treated with VENTOLIN HFA 2 inhalations 4 times daily for 2 weeks' duration. The population was 21 female, 25 male and 25 white, 17 black, 3 Hispanic, 1 other.

Adult and Adolescent Subjects Aged 12 Years and Older

The two 12-week, randomized, double-blind trials in 610 adult and adolescent subjects with asthma that compared VENTOLIN HFA, a CFC 11/12-propelled albuterol inhaler, and an HFA-134a placebo inhaler. Overall, the incidence and nature of the adverse reactions reported for VENTOLIN HFA and a CFC 11/12-propelled albuterol inhaler were comparable. Table 1 lists the incidence of all adverse reactions (whether considered by the investigator to be related or unrelated to drug) from these trials that occurred at a rate of $\geq 3\%$ in the group treated with VENTOLIN HFA and more frequently in the group treated with VENTOLIN HFA than in the HFA-134a placebo inhaler group.

Table 1. Adverse Reactions with VENTOLIN HFA with $\geq 3\%$ Incidence and More Common than Placebo in Adult and Adolescent Subjects

Adverse Reaction	Percent of Subjects		
	VENTOLIN HFA (n = 202) %	CFC 11/12-Propelled Albuterol Inhaler (n = 207) %	Placebo HFA-134a (n = 201) %
Ear, nose, and throat			
Throat irritation	10	6	7
Upper respiratory inflammation	5	5	2
Lower respiratory			
Viral respiratory infections	7	4	4
Cough	5	2	2
Musculoskeletal			
Musculoskeletal pain	5	5	4

Adverse reactions reported by $< 3\%$ of the adult and adolescent subjects receiving VENTOLIN HFA and by a greater proportion of subjects receiving VENTOLIN HFA than receiving HFA-134a placebo inhaler and that have the potential to be related to VENTOLIN HFA include diarrhea, laryngitis, oropharyngeal edema, cough, lung disorders, tachycardia, and extrasystoles. Palpitations and dizziness have also been observed with VENTOLIN HFA.

Pediatric Subjects Aged 4 to 11 Years

Results from the 2-week clinical trial in pediatric subjects with asthma aged 4 to 11 years showed that this pediatric population had an adverse reaction profile similar to that of the adult and adolescent populations.

Three trials have been conducted to evaluate the safety and efficacy of VENTOLIN HFA in subjects between birth and 4 years of age. The results of these trials did not establish the efficacy of VENTOLIN HFA in this age group [see *Use in Specific Populations (8.4)*]. Since the efficacy of VENTOLIN HFA has not been demonstrated in children between birth and 48 months of age,

the safety of VENTOLIN HFA in this age group cannot be established. However, the safety profile observed in the pediatric population younger than 4 years was comparable to that observed in the older pediatric subjects and in adults and adolescents. Where adverse reaction incidence rates were greater in subjects younger than 4 years compared with older subjects, the higher incidence rates were noted in all treatment arms, including placebo. These adverse reactions included upper respiratory tract infection, nasopharyngitis, pyrexia, and tachycardia.

6.2 Postmarketing Experience

In addition to adverse reactions reported from clinical trials, the following adverse reactions have been identified during postapproval use of albuterol sulfate. Because these reactions are reported voluntarily from a population of uncertain size, it is not always possible to reliably estimate their frequency or establish a causal relationship to drug exposure. These events have been chosen for inclusion due to either their seriousness, frequency of reporting, or causal connection to albuterol or a combination of these factors.

Cases of paradoxical bronchospasm, hoarseness, arrhythmias (including atrial fibrillation, supraventricular tachycardia), and hypersensitivity reactions (including urticaria, angioedema, rash) have been reported after the use of VENTOLIN HFA.

In addition, albuterol, like other sympathomimetic agents, can cause adverse reactions such as hypokalemia, hypertension, peripheral vasodilatation, angina, tremor, central nervous system stimulation, hyperactivity, sleeplessness, headache, muscle cramps, drying or irritation of the oropharynx, and metabolic acidosis.

7 DRUG INTERACTIONS

Other short-acting sympathomimetic aerosol bronchodilators should not be used concomitantly with albuterol. If additional adrenergic drugs are to be administered by any route, they should be used with caution to avoid deleterious cardiovascular effects.

7.1 Beta-Adrenergic Receptor Blocking Agents

Beta-blockers not only block the pulmonary effect of beta-agonists, such as VENTOLIN HFA, but may also produce severe bronchospasm in patients with asthma. Therefore, patients with asthma should not normally be treated with beta-blockers. However, under certain circumstances, there may be no acceptable alternatives to the use of beta-adrenergic blocking agents for these patients; cardioselective beta-blockers could be considered, although they should be administered with caution.

7.2 Non-Potassium-Sparing Diuretics

The ECG changes and/or hypokalemia that may result from the administration of non-potassium-sparing diuretics (such as loop or thiazide diuretics) can be acutely worsened by beta-agonists, especially when the recommended dose of the beta-agonist is exceeded. Although the clinical significance of these effects is not known, caution is advised in the coadministration

of VENTOLIN HFA with non-potassium-sparing diuretics.

7.3 Digoxin

Mean decreases of 16% to 22% in serum digoxin levels were demonstrated after single-dose intravenous and oral administration of albuterol, respectively, to normal volunteers who had received digoxin for 10 days. The clinical relevance of these findings for patients with obstructive airway disease who are receiving inhaled albuterol and digoxin on a chronic basis is unclear. Nevertheless, it would be prudent to carefully evaluate the serum digoxin levels in patients who are currently receiving digoxin and albuterol.

7.4 Monoamine Oxidase Inhibitors and Tricyclic Antidepressants

VENTOLIN HFA should be administered with extreme caution to patients being treated with monoamine oxidase inhibitors or tricyclic antidepressants, or within 2 weeks of discontinuation of such agents, because the action of albuterol on the vascular system may be potentiated.

8 USE IN SPECIFIC POPULATIONS

8.1 Pregnancy

Pregnancy Exposure Registry

There is a pregnancy exposure registry that monitors pregnancy outcomes in women exposed to asthma medications during pregnancy. For more information, contact the MotherToBaby Pregnancy Studies conducted by the Organization of Teratology Information Specialists at 1-877-311-8972 or visit <https://mothertobaby.org/ongoing-study/asthma/>.

Risk Summary

There are no randomized clinical studies of use of albuterol sulfate during pregnancy. Available data from epidemiological studies and postmarketing case reports of pregnancy outcomes following inhaled albuterol use do not consistently demonstrate a risk of major birth defects or miscarriage. There are, however, clinical considerations in pregnant women with asthma. (*See Clinical Considerations.*)

Administration of VENTOLIN HFA to mice and rabbits during the period of organogenesis revealed evidence of adverse developmental outcomes (cleft palate in mice, delayed ossification in rabbits) at less than the maximum recommended human daily inhaled dose (MRHDID). (*See Data.*)

The estimated background risk of major birth defects and miscarriage for the indicated population(s) is unknown. In the U.S. general population, the estimated risk of major birth defects and miscarriage in clinically recognized pregnancies is 2% to 4% and 15% to 20%, respectively.

Clinical Considerations

Disease-Associated Maternal and/or Embryofetal Risk: In women with poorly or moderately controlled asthma, there is an increased risk of several perinatal adverse outcomes such as preeclampsia in the mother and prematurity, low birth weight, and small for gestational age in the neonate. Pregnant women with asthma should be closely monitored and medication adjusted as necessary to maintain optimal asthma control.

Labor or Delivery: Because of the potential for beta-agonist interference with uterine contractility, use of VENTOLIN HFA during labor should be restricted to those patients in whom the benefits clearly outweigh the risk. VENTOLIN HFA has not been approved for the management of pre-term labor. Serious adverse reactions, including pulmonary edema, have been reported during or following treatment of premature labor with beta₂-agonists, including albuterol.

Data

Human Data: While available studies cannot definitively establish the absence of risk, published data from epidemiological studies and case reports have not consistently demonstrated an association with use of VENTOLIN HFA during pregnancy and major birth defects, specific birth defects, or miscarriage. The available studies have methodologic limitations, including inconsistent comparator groups, definitions of outcomes, and assessment of disease impact.

Animal Data: In a study in pregnant mice, subcutaneously administered albuterol sulfate produced cleft palate formation in 5 of 111 (4.5%) fetuses at an exposure less than the MRHDID for adults (on a mg/m² basis at a maternal dose of 0.25 mg/kg) and in 10 of 108 (9.3%) fetuses at approximately 9 times the MRHDID (on a mg/m² basis at a maternal dose of 2.5 mg/kg). Cleft palate also occurred in 22 of 72 (30.5%) fetuses from females treated subcutaneously with isoproterenol, another beta₂-agonist.

In a study in pregnant rabbits, orally administered albuterol sulfate produced cranioschisis in 7 of 19 fetuses (37%) at approximately 750 times the MRHDID (on a mg/m² basis at a maternal dose of 50 mg/kg).

In a study in pregnant rabbits, an albuterol/HFA-134a formulation administered by inhalation produced enlargement of the frontal portion of the fetal fontanelles at approximately one third of the MRHDID on a mg/m² basis.

A study in which pregnant rats were dosed with radiolabeled albuterol sulfate demonstrated that drug-related material is transferred from the maternal circulation to the fetus.

8.2 Lactation

Risk Summary

There are no available data on the presence of albuterol or the components of VENTOLIN HFA in human milk, the effects on the breastfed child, or the effects on milk production. However,

plasma levels of albuterol after inhaled therapeutic doses are low in humans, and if present in breast milk, are likely to be correspondingly low [see *Clinical Pharmacology (12.3)*]. The developmental and health benefits of breastfeeding should be considered along with the mother's clinical need for VENTOLIN HFA and any potential adverse effects on the breastfed child from VENTOLIN HFA or from the underlying maternal condition.

8.4 Pediatric Use

The safety and effectiveness of VENTOLIN HFA in children aged 4 years and older have been established based upon two 12-week clinical trials in subjects aged 12 years and older with asthma and one 2-week clinical trial in subjects aged 4 to 11 years with asthma [see *Adverse Reactions (6.1)*, *Clinical Studies (14.1)*]. The safety and effectiveness of VENTOLIN HFA in children younger than 4 years have not been established. Three trials have been conducted to evaluate the safety and efficacy of VENTOLIN HFA in subjects younger than 4 years and the findings are described below.

Two 4-week randomized, double-blind, placebo-controlled trials were conducted in 163 pediatric subjects aged from birth to 48 months with symptoms of bronchospasm associated with obstructive airway disease (presenting symptoms included: wheeze, cough, dyspnea, or chest tightness). VENTOLIN HFA or placebo HFA was delivered with either an AeroChamber Plus Valved Holding Chamber or an Optichamber Valved Holding Chamber with mask 3 times daily. In one trial, VENTOLIN HFA 90 mcg (n = 26), VENTOLIN HFA 180 mcg (n = 25), and placebo HFA (n = 26) were administered to children aged between 24 and 48 months. In the second trial, VENTOLIN HFA 90 mcg (n = 29), VENTOLIN HFA 180 mcg (n = 29), and placebo HFA (n = 28) were administered to children aged between birth and 24 months. Over the 4-week treatment period, there were no treatment differences in asthma symptom scores between the groups receiving VENTOLIN HFA 90 mcg, VENTOLIN HFA 180 mcg, and placebo in either trial.

In a third trial, VENTOLIN HFA was evaluated in 87 pediatric subjects younger than 24 months for the treatment of acute wheezing. VENTOLIN HFA was delivered with an AeroChamber Plus Valved Holding Chamber in this trial. There were no significant differences in asthma symptom scores and mean change from baseline in an asthma symptom score between VENTOLIN HFA 180 mcg and VENTOLIN HFA 360 mcg.

In vitro dose characterization studies were performed to evaluate the delivery of VENTOLIN HFA via holding chambers with attached masks. The studies were conducted with 2 different holding chambers with masks (small and medium size). The in vitro study data when simulating patient breathing suggest that the dose of VENTOLIN HFA presented for inhalation via a valved holding chamber with mask will be comparable to the dose delivered in adults without a spacer and mask per kilogram of body weight (Table 2). However, clinical trials in children younger than 4 years described above suggest that either the optimal dose of VENTOLIN HFA has not been defined in this age group or VENTOLIN HFA is not effective in this age group. The safety

and effectiveness of VENTOLIN HFA administered with or without a spacer device in children younger than 4 years have not been demonstrated.

Table 2. In Vitro Medication Delivery through AeroChamber Plus Valved Holding Chamber with a Mask

Age	Mask	Flow Rate (L/min)	Holding Time (seconds)	Mean Medication Delivery through AeroChamber Plus (mcg/actuation)	Body Weight 50 th Percentile (kg) ^a	Medication Delivered per Actuation (mcg/kg) ^b
6 to 12 Months	Small	4.9	0	18.2	7.5-9.9	1.8-2.4
			2	19.8		2.0-2.6
			5	13.8		1.4-1.8
			10	15.4		1.6-2.1
2 to 5 Years	Small	8.0	0	17.8	12.3-18.0	1.0-1.4
			2	16.0		0.9-1.3
			5	16.3		0.9-1.3
			10	18.3		1.0-1.5
2 to 5 Years	Medium	8.0	0	21.1	12.3-18.0	1.2-1.7
			2	15.3		0.8-1.2
			5	18.3		1.0-1.5
			10	18.2		1.0-1.5
>5 Years	Medium	12.0	0	26.8	18.0	1.5
			2	20.9		1.2
			5	19.6		1.1
			10	20.3		1.1

^a Centers for Disease Control growth charts, developed by the National Center for Health Statistics in collaboration with the National Center for Chronic Disease Prevention and Health Promotion (2000). Ranges correspond to the average of the 50th percentile weight for boys and girls at the ages indicated.

^b A single inhalation of VENTOLIN HFA in a 70-kg adult without use of a valved holding chamber and mask delivers approximately 90 mcg, or 1.3 mcg/kg.

8.5 Geriatric Use

Clinical trials of VENTOLIN HFA did not include sufficient numbers of subjects aged 65 years and older to determine whether older subjects respond differently than younger subjects. Other reported clinical experience has not identified differences in responses between the elderly and younger patients. In general, dose selection for an elderly patient should be cautious, usually starting at the low end of the dosing range, reflecting the greater frequency of decreased hepatic,

renal, or cardiac function, and of concomitant disease or other drug therapy.

10 OVERDOSAGE

The expected signs and symptoms with overdosage of albuterol are those of excessive beta-adrenergic stimulation and/or occurrence or exaggeration of any of the signs and symptoms of beta-adrenergic stimulation (e.g., seizures, angina, hypertension or hypotension, tachycardia with rates up to 200 beats/min, arrhythmias, nervousness, headache, tremor, muscle cramps, dry mouth, palpitation, nausea, dizziness, fatigue, malaise, insomnia, hyperglycemia, hypokalemia, metabolic acidosis).

As with all inhaled sympathomimetic medicines, cardiac arrest and even death may be associated with an overdose of VENTOLIN HFA Inhalation Aerosol.

Treatment consists of discontinuation of VENTOLIN HFA together with appropriate symptomatic therapy. The judicious use of a cardioselective beta-receptor blocker may be considered, bearing in mind that such medication can produce bronchospasm. There is insufficient evidence to determine if dialysis is beneficial for overdosage of VENTOLIN HFA.

11 DESCRIPTION

The active component of VENTOLIN HFA is albuterol sulfate, USP, the racemic form of albuterol and a relatively selective beta₂-adrenergic bronchodilator. Albuterol sulfate has the chemical name α^1 -[(*tert*-butylamino)methyl]-4-hydroxy-*m*-xylene- α , α' -diol sulfate (2:1)(salt) and the following chemical structure:

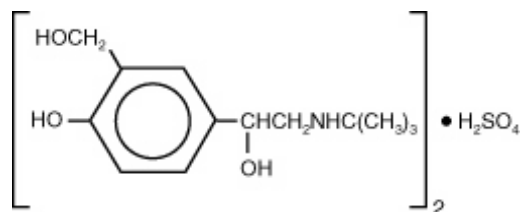

Albuterol sulfate is a white crystalline powder with a molecular weight of 576.7, and the empirical formula is (C₁₃H₂₁NO₃)₂•H₂SO₄. It is soluble in water and slightly soluble in ethanol.

The World Health Organization recommended name for albuterol base is salbutamol.

VENTOLIN HFA is a blue plastic inhaler with a blue strapcap containing a pressurized metered-dose aerosol canister fitted with a counter. Each canister contains a microcrystalline suspension of albuterol sulfate in propellant HFA-134a (1,1,1,2-tetrafluoroethane). It contains no other excipients.

After priming, each actuation of the inhaler delivers 120 mcg of albuterol sulfate, USP in 75 mg of suspension from the valve and 108 mcg of albuterol sulfate, USP from the mouthpiece (equivalent to 90 mcg of albuterol base from the mouthpiece).

Prime VENTOLIN HFA before using for the first time, when the inhaler has not been used for

more than 2 weeks, or when the inhaler has been dropped. To prime VENTOLIN HFA, release 4 sprays into the air away from the face, shaking well before each spray.

12 CLINICAL PHARMACOLOGY

12.1 Mechanism of Action

In vitro studies and in vivo pharmacologic studies have demonstrated that albuterol has a preferential effect on beta₂-adrenergic receptors compared with isoproterenol. Although beta₂-adrenoceptors are the predominant adrenergic receptors in bronchial smooth muscle and beta₁-adrenoceptors are the predominant receptors in the heart, there are also beta₂-adrenoceptors in the human heart comprising 10% to 50% of the total beta-adrenoceptors. The precise function of these receptors has not been established, but their presence raises the possibility that even selective beta₂-agonists may have cardiac effects.

Activation of beta₂-adrenergic receptors on airway smooth muscle leads to the activation of adenylyl cyclase and to an increase in the intracellular concentration of cyclic-3',5'-adenosine monophosphate (cyclic AMP). This increase of cyclic AMP leads to the activation of protein kinase A, which inhibits the phosphorylation of myosin and lowers intracellular ionic calcium concentrations, resulting in relaxation. Albuterol relaxes the smooth muscles of all airways, from the trachea to the terminal bronchioles. Albuterol acts as a functional antagonist to relax the airway irrespective of the spasmogen involved, thus protecting against all bronchoconstrictor challenges. Increased cyclic AMP concentrations are also associated with the inhibition of release of mediators from mast cells in the airway.

Albuterol has been shown in most controlled clinical trials to have more effect on the respiratory tract, in the form of bronchial smooth muscle relaxation, than isoproterenol at comparable doses while producing fewer cardiovascular effects. Controlled clinical studies and other clinical experience have shown that inhaled albuterol, like other beta-adrenergic agonist drugs, can produce a significant cardiovascular effect in some patients, as measured by pulse rate, blood pressure, symptoms, and/or electrocardiographic changes [*see Warnings and Precautions (5.4)*].

12.3 Pharmacokinetics

The systemic levels of albuterol are low after inhalation of recommended doses. A trial conducted in 12 healthy male and female subjects using a higher dose (1,080 mcg of albuterol base) showed that mean peak plasma concentrations of approximately 3 ng/mL occurred after dosing when albuterol was delivered using propellant HFA-134a. The mean time to peak concentrations (T_{max}) was delayed after administration of VENTOLIN HFA ($T_{max} = 0.42$ hours) as compared with CFC-propelled albuterol inhaler ($T_{max} = 0.17$ hours). Apparent terminal plasma half-life of albuterol is approximately 4.6 hours. No further pharmacokinetic trials for VENTOLIN HFA were conducted in neonates, children, or elderly subjects.

13 NONCLINICAL TOXICOLOGY

13.1 Carcinogenesis, Mutagenesis, Impairment of Fertility

In a 2-year study in Sprague-Dawley rats, albuterol sulfate caused a dose-related increase in the incidence of benign leiomyomas of the mesovarium at and above dietary doses of 2 mg/kg (approximately 15 and 6 times the MRHDID for adults and children, respectively, on a mg/m² basis). In another study this effect was blocked by the coadministration of propranolol, a non-selective beta-adrenergic antagonist. In an 18-month study in CD-1 mice, albuterol sulfate showed no evidence of tumorigenicity at dietary doses of up to 500 mg/kg (approximately 1,900 and 740 times the MRHDID for adults and children, respectively, on a mg/m² basis). In a 22-month study in Golden hamsters, albuterol sulfate showed no evidence of tumorigenicity at dietary doses of up to 50 mg/kg (approximately 250 and 100 times the MRHDID for adults and children, respectively, on a mg/m² basis).

Albuterol sulfate was not mutagenic in the Ames test or a mutation test in yeast. Albuterol sulfate was not clastogenic in a human peripheral lymphocyte assay or in an AH1 strain mouse micronucleus assay.

Fertility and reproductive performance in rats demonstrated no evidence of impaired fertility at oral doses up to 50 mg/kg (approximately 380 times the MRHDID for adults on a mg/m² basis).

13.2 Animal Toxicology and/or Pharmacology

Preclinical

Intravenous studies in rats with albuterol sulfate have demonstrated that albuterol crosses the blood-brain barrier and reaches brain concentrations amounting to approximately 5% of the plasma concentrations. In structures outside the blood-brain barrier (pineal and pituitary glands), albuterol concentrations were found to be 100 times those in the whole brain.

Studies in laboratory animals (minipigs, rodents, and dogs) have demonstrated the occurrence of cardiac arrhythmias and sudden death (with histologic evidence of myocardial necrosis) when beta-agonists and methylxanthines are administered concurrently. The clinical relevance of these findings is unknown.

14 CLINICAL STUDIES

14.1 Bronchospasm Associated with Asthma

Adult and Adolescent Subjects Aged 12 Years and Older

The efficacy of VENTOLIN HFA was evaluated in two 12-week, randomized, double-blind, placebo-controlled trials in subjects aged 12 years and older with mild to moderate asthma. These trials included a total of 610 subjects (323 males, 287 females). In each trial, subjects received 2 inhalations of VENTOLIN HFA, CFC 11/12-propelled albuterol, or HFA-134a placebo 4 times daily for 12 weeks' duration. Subjects taking the HFA-134a placebo inhaler also took

VENTOLIN HFA for asthma symptom relief on an as-needed basis. Some subjects who participated in these clinical trials were using concomitant inhaled steroid therapy. Efficacy was assessed by serial forced expiratory volume in 1 second (FEV₁). In each of these trials, 2 inhalations of VENTOLIN HFA produced significantly greater improvement in FEV₁ over the pretreatment value than placebo. Results from the 2 clinical trials are described below.

In a 12-week, randomized, double-blind trial, VENTOLIN HFA (101 subjects) was compared with CFC 11/12-propelled albuterol (99 subjects) and an HFA-134a placebo inhaler (97 subjects) in adolescent and adult subjects aged 12 to 76 years with mild to moderate asthma. Serial FEV₁ measurements [shown below as percent change from test-day baseline at Day 1 (n = 297) and at Week 12 (n = 249)] demonstrated that 2 inhalations of VENTOLIN HFA produced significantly greater improvement in FEV₁ over the pretreatment value than placebo.

FEV₁ as Percent Change from Predose in a Large, 12-Week Clinical Trial

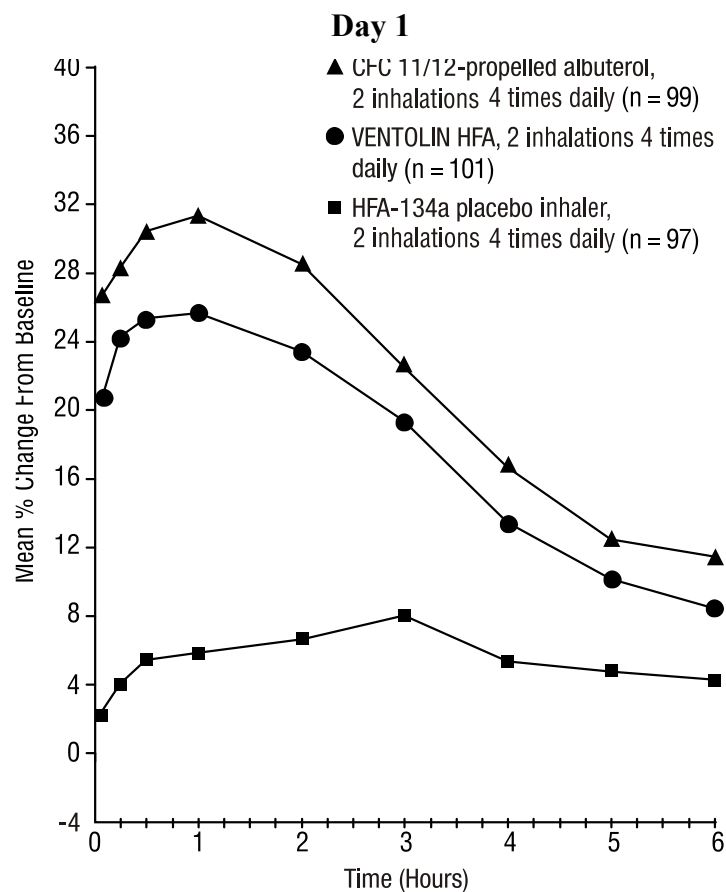

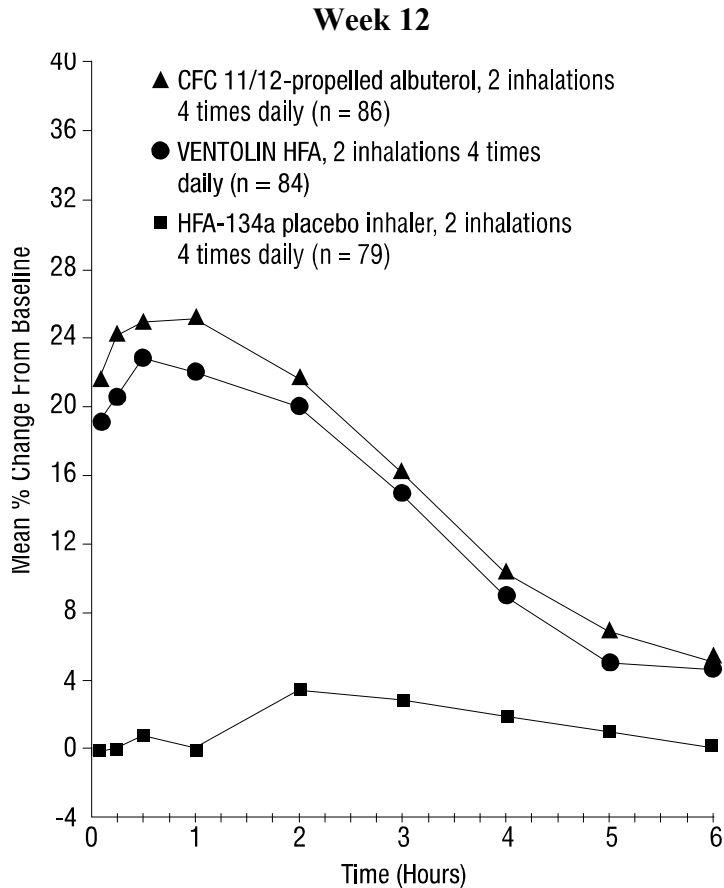

In the responder population ($\geq 15\%$ increase in FEV₁ within 30 minutes postdose) treated with VENTOLIN HFA, the mean time to onset of a 15% increase in FEV₁ over the pretreatment value was 5.4 minutes, and the mean time to peak effect was 56 minutes. The mean duration of effect as measured by a 15% increase in FEV₁ over the pretreatment value was approximately 4 hours. In some subjects, duration of effect was as long as 6 hours.

The second 12-week randomized, double-blind trial was conducted to evaluate the efficacy and safety of switching subjects from CFC 11/12-propelled albuterol to VENTOLIN HFA. During the 3-week run-in phase of the trial, all subjects received CFC 11/12-propelled albuterol. During the double-blind treatment phase, VENTOLIN HFA (91 subjects) was compared to CFC 11/12-propelled albuterol (100 subjects) and an HFA-134a placebo inhaler (95 subjects) in adult and adolescent subjects with mild to moderate asthma. Serial FEV₁ measurements demonstrated that 2 inhalations of VENTOLIN HFA produced significantly greater improvement in pulmonary function than placebo. The switching from CFC 11/12-propelled albuterol inhaler to VENTOLIN HFA did not reveal any clinically significant changes in the efficacy profile.

In the 2 adult trials, the efficacy results from VENTOLIN HFA were significantly greater than placebo and were clinically comparable to those achieved with CFC 11/12-propelled albuterol, although small numerical differences in mean FEV₁ response and other measures were observed.

Physicians should recognize that individual responses to beta-adrenergic agonists administered via different propellants may vary and that equivalent responses in individual patients should not be assumed.

Pediatric Subjects Aged 4 to 11 Years

The efficacy of VENTOLIN HFA was evaluated in one 2-week, randomized, double-blind, placebo-controlled trial in 135 pediatric subjects aged 4 to 11 years with mild to moderate asthma. In this trial, subjects received VENTOLIN HFA, CFC 11/12-propelled albuterol, or HFA-134a placebo. Serial pulmonary function measurements demonstrated that 2 inhalations of VENTOLIN HFA produced significantly greater improvement in pulmonary function than placebo and that there were no significant differences between the groups treated with VENTOLIN HFA and CFC 11/12-propelled albuterol. In the responder population treated with VENTOLIN HFA, the mean time to onset of a 15% increase in peak expiratory flow rate (PEFR) over the pretreatment value was 7.8 minutes, and the mean time to peak effect was approximately 90 minutes. The mean duration of effect as measured by a 15% increase in PEFR over the pretreatment value was greater than 3 hours. In some subjects, duration of effect was as long as 6 hours.

14.2 Exercise-Induced Bronchospasm

One controlled clinical trial in adult subjects with asthma (N = 24) demonstrated that 2 inhalations of VENTOLIN HFA taken approximately 30 minutes prior to exercise significantly prevented exercise-induced bronchospasm (as measured by maximum percentage fall in FEV₁ following exercise) compared with an HFA-134a placebo inhaler. In addition, VENTOLIN HFA was shown to be clinically comparable to a CFC 11/12-propelled albuterol inhaler for this indication.

16 HOW SUPPLIED/STORAGE AND HANDLING

VENTOLIN HFA Inhalation Aerosol is supplied in the following boxes of 1 as a pressurized aluminum canister fitted with a counter and supplied with a blue plastic actuator with a blue strapcap:

NDC 0173-0682-20 18-g canister containing 200 actuations

NDC 0173-0682-24 8-g canister containing 60 actuations

Each inhaler is sealed in a moisture-protective foil pouch with a desiccant that should be discarded when the pouch is opened. Each inhaler is packaged with a Patient Information leaflet.

The blue actuator supplied with VENTOLIN HFA should not be used with any other product canisters, and actuators from other products should not be used with a VENTOLIN HFA canister.

VENTOLIN HFA has a counter attached to the canister. The counter starts at 204 or 64 and counts down each time a spray is released. The correct amount of medication in each actuation

cannot be assured after the counter reads 000, even though the canister is not completely empty and will continue to operate. The inhaler should be discarded when the counter reads 000 or 12 months after removal from the moisture-protective foil pouch, whichever comes first.

Keep out of reach of children. Avoid spraying in eyes.

Contents Under Pressure: Do not puncture. Do not use or store near heat or open flame. Exposure to temperatures above 120°F may cause bursting. Never throw canister into fire or incinerator.

Store at room temperature between 68°F and 77°F (20°C and 25°C); excursions permitted from 59°F to 86°F (15°C to 30°C) [See USP Controlled Room Temperature]. Store the inhaler with the mouthpiece down. For best results, the inhaler should be at room temperature before use. SHAKE WELL BEFORE EACH SPRAY.

17 PATIENT COUNSELING INFORMATION

Advise the patient to read the FDA-approved patient labeling (Patient Information and Instructions for Use).

Frequency of Use

Inform patients that the action of VENTOLIN HFA should last up to 4 to 6 hours. Do not use VENTOLIN HFA more frequently than recommended. Instruct patients not to increase the dose or frequency of doses of VENTOLIN HFA without consulting the physician. Instruct patients to seek medical attention immediately if treatment with VENTOLIN HFA becomes less effective for symptomatic relief, symptoms become worse, and/or they need to use the product more frequently than usual.

Priming

Instruct patients to prime VENTOLIN HFA before using for the first time, when the inhaler has not been used for more than 2 weeks, or when the inhaler has been dropped. To prime VENTOLIN HFA, release 4 sprays into the air away from the face, shaking well before each spray.

Cleaning

To ensure proper dosing and to prevent actuator orifice blockage, instruct patients to wash the actuator with warm water and let it air-dry completely at least once a week. Inform patients that detailed cleaning instructions are included in the Patient Information leaflet.

Paradoxical Bronchospasm

Inform patients that VENTOLIN HFA can produce paradoxical bronchospasm. Instruct them to discontinue VENTOLIN HFA if paradoxical bronchospasm occurs.

Concomitant Drug Use

Advise patients that while they are using VENTOLIN HFA, other inhaled drugs and asthma medications should be taken only as directed by the physician.

Common Adverse Effects

Common adverse effects of treatment with inhaled albuterol include palpitations, chest pain, rapid heart rate, tremor, and nervousness.

Pregnancy Exposure Registry

Inform women there is a pregnancy exposure registry that monitors pregnancy outcomes in women exposed to asthma medications, including VENTOLIN HFA, during pregnancy and that they can enroll in the Pregnancy Exposure Registry by calling 1-877-311-8972 or by visiting <https://mothertobaby.org/ongoing-study/asthma> [see *Use in Specific Populations (8.1)*].

VENTOLIN is owned by or licensed to the GSK group of companies.

The other brands listed are trademarks owned by or licensed to their respective owners and are not owned by or licensed to the GSK group of companies. The makers of these brands are not affiliated with and do not endorse the GSK group of companies or its products.



GlaxoSmithKline
Research Triangle Park, NC 27709

©2019 GSK group of companies or its licensor.

VNT:xxPI

PHARMACIST DETACH HERE AND GIVE LEAFLET TO PATIENT

PATIENT INFORMATION
VENTOLIN (VENT o lin) HFA
(albuterol sulfate)
Inhalation Aerosol
for oral inhalation use

What is VENTOLIN HFA?

- VENTOLIN HFA is a prescription inhaled medicine used in people aged 4 years and older to:
 - treat or prevent bronchospasm in people who have reversible obstructive airway disease.
 - prevent exercise-induced bronchospasm.
- It is not known if VENTOLIN HFA is safe and effective in children younger than 4 years of age.

Do not use VENTOLIN HFA:

- if you are allergic to albuterol sulfate propionate or any of the ingredients in VENTOLIN HFA. See the end of this Patient Information for a complete list of ingredients in VENTOLIN HFA.

Before using VENTOLIN HFA, tell your healthcare provider about all of your medical conditions, including if you:

- have heart problems.
- have high blood pressure.
- have seizures.
- have thyroid problems.
- have diabetes.
- have low potassium levels in your blood.
- are pregnant or plan to become pregnant. It is not known if VENTOLIN HFA may harm your unborn baby.
 - **Pregnancy Registry.** There is a pregnancy registry for women with asthma who receive asthma medications, including VENTOLIN HFA, while pregnant. The purpose of the registry is to collect information about the health of you and your baby. You can talk to your healthcare provider about how to take part in this registry or you can get more information and register by calling 1-877-311-8972 or go to <https://mothertobaby.org/ongoing-study/asthma>.
- are breastfeeding. It is not known if the medicine in VENTOLIN HFA passes into your milk and if it can harm your baby.

Tell your healthcare provider about all the medicines you take, including prescription and over-the-counter medicines, vitamins, and herbal supplements. VENTOLIN HFA and certain other medicines may interact with each other. This may cause serious side effects. Especially tell your healthcare provider if you take:

- other inhaled medicines or asthma medicines
- beta-blocker medicines
- diuretics
- digoxin
- monoamine oxidase inhibitors
- tricyclic antidepressants

Know the medicines you take. Keep a list of them to show your healthcare provider and pharmacist when you get a new medicine.

How should I use VENTOLIN HFA?

Read the step-by-step instructions for using VENTOLIN HFA at the end of this Patient Information.

- **Do not** use VENTOLIN HFA unless your healthcare provider has taught you how to use the inhaler and you understand how to use it correctly.
- Children should use VENTOLIN HFA with an adult's help, as instructed by the child's healthcare provider.
- Use VENTOLIN HFA exactly as your healthcare provider tells you to use it. **Do not** use VENTOLIN HFA more often than prescribed.
- **Do not** increase your dose or take extra doses of VENTOLIN HFA without first talking to your healthcare provider.
- Each dose of VENTOLIN HFA should last up to 4 hours to 6 hours.
- Get medical help right away if VENTOLIN HFA no longer helps your symptoms.
- Get medical help right away if your symptoms get worse or if you need to use your inhaler more often.
- While you are using VENTOLIN HFA, use other inhaled medicines and asthma medicines only as directed by your healthcare provider.
- Call your healthcare provider if your asthma symptoms like wheezing and trouble breathing become worse over a few hours or days. Your healthcare provider may need to give you another medicine to treat your symptoms.

What are the possible side effects of VENTOLIN HFA?

VENTOLIN HFA can cause serious side effects, including:

- **worsening trouble breathing, coughing, and wheezing (paradoxical bronchospasm).** If this happens, stop using VENTOLIN HFA and call your healthcare provider or get emergency help right away. Paradoxical bronchospasm is more likely to happen with your first use of a new canister of medicine.
- **heart problems, including faster heart rate and higher blood pressure.**
- **possible death in people with asthma who use too much VENTOLIN HFA.**
- **serious allergic reactions.** Call your healthcare provider or get emergency medical care if you get any of the following symptoms of a serious allergic reaction:
 - rash
 - hives
 - swelling of your face, mouth, and tongue
 - breathing problems
- **changes in laboratory blood levels (sugar, potassium).**

Common side effects of VENTOLIN HFA include:

- sore throat
- upper respiratory tract infection, including viral infection
- cough
- muscle pain
- your heart feels like it is pounding or racing (palpitations)
- chest pain
- fast heart rate
- shakiness
- nervousness
- dizziness

These are not all the possible side effects of VENTOLIN HFA.

Call your doctor for medical advice about side effects. You may report side effects to FDA at 1-800-FDA-1088.

How should I store VENTOLIN HFA?

- Store VENTOLIN HFA at room temperature between 68°F and 77°F (20°C and 25°C) with the mouthpiece down.

- **The contents of your VENTOLIN HFA are under pressure: Do not puncture. Do not use or store near heat or open flame.** Temperatures above 120°F may cause the canister to burst.
- **Do not** throw into fire or an incinerator.
- Store VENTOLIN HFA in the unopened foil pouch and only open when ready for use.

Keep VENTOLIN HFA and all medicines out of the reach of children.

General information about the safe and effective use of VENTOLIN HFA.

Medicines are sometimes prescribed for purposes other than those listed in a Patient Information leaflet. Do not use VENTOLIN HFA for a condition for which it was not prescribed. Do not give VENTOLIN HFA to other people, even if they have the same symptoms that you have. It may harm them.

You can ask your healthcare provider or pharmacist for information about VENTOLIN HFA that was written for health professionals.

What are the ingredients in VENTOLIN HFA?

Active ingredient: albuterol sulfate

Inactive ingredient: propellant HFA-134a



For more information about VENTOLIN HFA, call 1-888-825-5249 or visit our website at www.ventolin.com.

Trademarks are owned by or licensed to the GSK group of companies.

GlaxoSmithKline, Research Triangle Park, NC 27709

©2019 GSK group of companies or its licensor.

VNT:xPIL

This Patient Information has been approved by the U.S. Food and Drug Administration

Revised: December 2019

INSTRUCTIONS FOR USE
VENTOLIN (VENT o lin) HFA
(albuterol sulfate)
Inhalation Aerosol
for oral inhalation use

Your VENTOLIN HFA inhaler

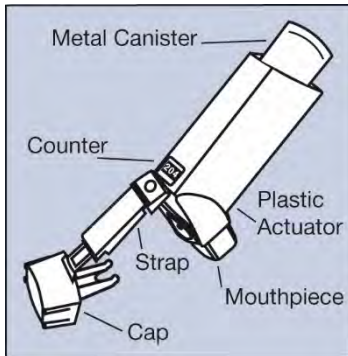

Figure A

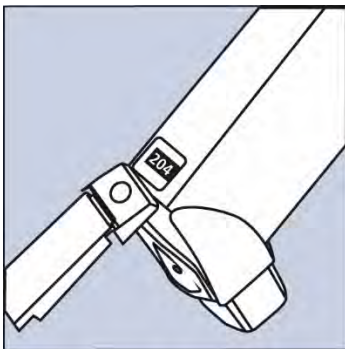

Figure B

- The metal canister holds the medicine. **See Figure A.**
- The metal canister has a counter to show how many sprays of medicine you have left. The number shows through a window in the back of the plastic actuator. **See Figure B.**
- The counter starts at either **204** or **064**, depending on which size inhaler you have. The number will count down by 1 each time you spray the inhaler. The counter will stop counting at **000**.
- **Do not try to change the numbers or take the counter off the metal canister.** The counter cannot be reset, and it is permanently attached to the metal canister.
- The blue plastic actuator sprays the medicine from the metal canister. The plastic actuator has a protective cap that covers the mouthpiece. **See Figure A.** Keep the protective cap on the mouthpiece when the metal canister is not in use. The strap keeps the cap attached to the plastic actuator.
- **Do not** use the plastic actuator with a canister of medicine from any other inhaler.
- **Do not** use a VENTOLIN HFA metal canister with an actuator from any other inhaler.

Before using your VENTOLIN HFA inhaler

- Take VENTOLIN HFA out of the foil pouch just before you use it for the first time. Safely throw away the pouch and the drying packet that comes inside the pouch.
- The inhaler should be at room temperature before you use it.
- If your child needs to use VENTOLIN HFA, watch your child closely to make sure your child uses the inhaler correctly. Your healthcare provider will show you how your child should use VENTOLIN HFA.

Priming your VENTOLIN HFA inhaler

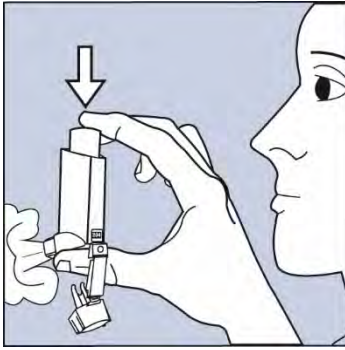

Figure C

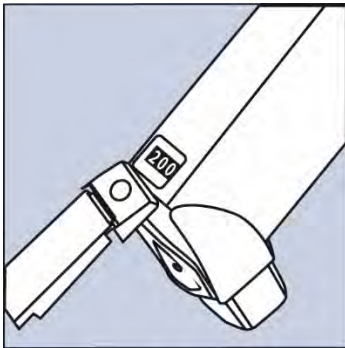

Figure D

How to use your VENTOLIN HFA inhaler

Follow these steps every time you use VENTOLIN HFA.

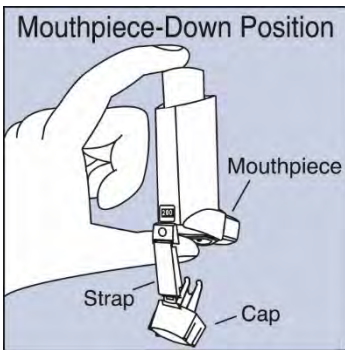

Figure E

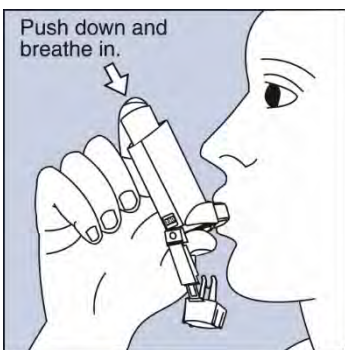

Figure F

- Before you use VENTOLIN HFA for the first time, you must prime the inhaler so that you will get the right amount of medicine when you use it.
- To prime the inhaler, take the cap off the mouthpiece and shake the inhaler well. Then spray the inhaler 1 time into the air away from your face. **See Figure C. Avoid spraying in eyes.**
- Shake and spray the inhaler like this 3 more times to finish priming it. The counter should now read **200** or **060**, depending on which size inhaler you have. **See Figure D.**
- You must prime your inhaler again if you have not used it in more than 14 days or if you drop it. Take the cap off the mouthpiece and shake and spray the inhaler 4 more times into the air away from your face.

Step 1. Make sure the metal canister fits firmly in the plastic actuator. The counter should show through the window in the actuator.

Shake the inhaler well before each spray.

Take the cap off the mouthpiece of the plastic actuator. Look inside the mouthpiece for foreign objects and take out any you see.

Step 2. Hold the inhaler with the mouthpiece down. **See Figure E.**

Step 3. Breathe out through your mouth and push as much air from your lungs as you can. Put the mouthpiece in your mouth and close your lips around it. **See Figure F.**

Step 4. Push the top of the metal canister **all the way down** while you breathe in deeply and slowly through your mouth. **See Figure F.**

Step 5. After the spray comes out, take your finger off the metal canister. After you have breathed in all the way, take the inhaler out of your mouth and close your mouth.

Step 6. **Hold your breath for about 10 seconds**, or for as long as is comfortable. **Breathe out slowly as long as you can.**

If your healthcare provider has told you to use more sprays, wait 1 minute and shake the inhaler again. Repeat Steps 2 through Step 6.

Step 7. Put the cap back on the mouthpiece after every time you use the inhaler. Make sure it snaps firmly into place.

Cleaning your VENTOLIN HFA inhaler

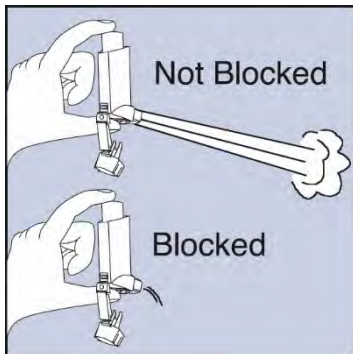

Figure G

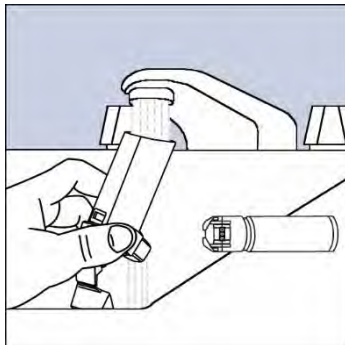

Figure H

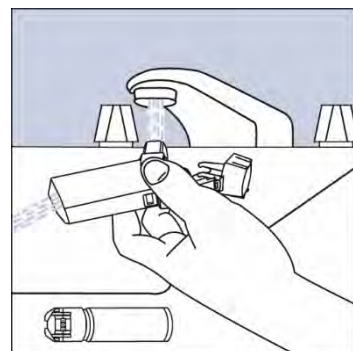

Figure I

Clean your inhaler at least 1 time each week. You may not see any medicine build-up on the inhaler, but it is important to keep it clean so medicine build-up will not block the spray. **See**

Figure G.

Step 8. Take the canister out of the actuator and take the cap off the mouthpiece. The strap on the cap will stay attached to the actuator.

Step 9. Hold the actuator under the faucet and run warm water through it for about 30 seconds. **See Figure H.**

Step 10. Turn the actuator upside down and run warm water through the mouthpiece for about 30 seconds. **See Figure I.**

Step 11. Shake off as much water from the actuator as you can. Look into the mouthpiece to make sure any medicine build-up has been completely washed away. If there is any build-up, repeat Steps 9 and 10.

Step 12. Let the actuator air-dry overnight. **See Figure J.**

Step 13. When the actuator is dry, put the protective cap on the mouthpiece and then put the canister in the actuator and make sure it fits firmly. Shake the inhaler well, remove the cap, and spray the inhaler once into the air away from your face. (The counter will count down by 1 number.) Put the cap back on the mouthpiece.

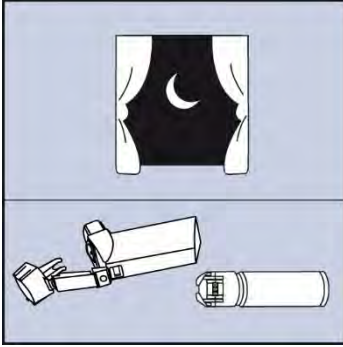

Figure J

If you need to use your inhaler before the actuator is completely dry:

- Shake as much water off the actuator as you can.
- Put the cap on the mouthpiece and then put the canister in the actuator and make sure it fits firmly.
- Shake the inhaler well and spray it 1 time into the air away from your face.
- Take your VENTOLIN HFA dose as prescribed.
- Follow cleaning Steps 8 through 13 above.

Replacing your VENTOLIN HFA inhaler

- **When the counter reads 020**, you should refill your prescription or ask your healthcare provider if you need another prescription for VENTOLIN HFA.
- **Throw the inhaler away** when the counter reads **000** or 12 months after you opened the foil pouch, whichever comes first. You should not keep using the inhaler when the counter reads **000** because you will not receive the right amount of medicine.
- **Do not use the inhaler** after the expiration date, which is on the packaging it comes in.

For correct use of your VENTOLIN HFA inhaler, remember:

- The metal canister should always fit firmly in the plastic actuator.
- Breathe in deeply and slowly to make sure you get all the medicine.
- Hold your breath for about 10 seconds after breathing in the medicine. Then breathe out fully.
- Always keep the protective cap on the mouthpiece when your inhaler is not in use.
- Always store your inhaler with the mouthpiece pointing down.
- Clean your inhaler at least 1 time each week.



For more information about VENTOLIN HFA or how to use your inhaler, call 1-888-825-5249 or visit our website at www.ventolin.com.

Trademarks are owned by or licensed to the GSK group of companies.

GlaxoSmithKline, Research Triangle Park, NC 27709

©2019 GSK group of companies or its licensor.

VNT:xIFU

This Instructions for Use has been approved by the U.S. Food and Drug Administration Revised: December 2019

PRODUCT MONOGRAPH
INCLUDING PATIENT MEDICATION INFORMATION

Pr**Victoza**[®]

liraglutide injection

6 mg/mL

Solution for Injection in a pre-filled pen

Human Glucagon Like Peptide-1 (GLP-1)

Novo Nordisk Canada Inc.
101-2476 Argentia Road
Mississauga, Ontario
L5N 6M1

Date of Revision:
May 27, 2020

Submission Control No: 239944

Date of Approval:
October 19, 2020

RECENT MAJOR LABEL CHANGES

Indications, General (1) FEB, 2020

Indications, Pediatrics (1.1) FEB, 2020

Dosage and Administration, Recommended Dose and Dosage Adjustment (4.2) FEB, 2020

TABLE OF CONTENTS

RECENT MAJOR LABEL CHANGES	1
TABLE OF CONTENTS	2
PART I: HEALTH PROFESSIONAL INFORMATION	4
1 INDICATIONS	4
1.1 Pediatrics.....	4
1.2 Geriatrics.....	4
2 CONTRAINDICATIONS	5
3 SERIOUS WARNINGS AND PRECAUTIONS BOX	5
4 DOSAGE AND ADMINISTRATION	5
4.1 Dosing Considerations	5
4.2 Recommended Dose and Dosage Adjustment.....	6
4.3 Administration	7
4.4 Missed Dose.....	7
5 OVERDOSAGE	7
6 DOSAGE FORMS, STRENGTHS, COMPOSITION AND PACKAGING	7
7 DESCRIPTION	8
8 WARNINGS AND PRECAUTIONS	8
8.1 Special Populations.....	10
8.1.1 Pregnant Women.....	10
8.1.2 Breast-feeding	10
8.1.3 Pediatrics	10
8.1.4 Geriatrics	10
8.1.5 Cardiovascular.....	10
8.1.6 Hepatic Insufficiency	11
8.1.7 Renal Insufficiency	11
8.1.8 Gastrointestinal Disease	11
8.1.9 Hypersensitivity Reactions.....	11
8.1.10 Thyroid Disease.....	11
8.1.11 Acute Gallbladder Disease	11
8.2 Monitoring and Laboratory Tests	12
9 ADVERSE REACTIONS	12
9.1 Adverse Reaction Overview	12
9.2 Clinical Trial Adverse Reactions	12
9.3 Less Common Clinical Trial Adverse Reactions.....	28

9.4	Clinical Trial Adverse Reactions (Pediatrics).....	28
9.5	Post-Market Adverse Reactions.....	29
10	DRUG INTERACTIONS.....	30
10.1	Overview	30
10.2	Drug-Drug Interactions	30
10.3	Drug-Food Interactions	31
10.4	Drug-Herb Interactions	31
11	ACTION AND CLINICAL PHARMACOLOGY.....	31
11.1	Mechanism of Action.....	31
11.2	Pharmacodynamics.....	32
11.3	Pharmacokinetics	36
12	STORAGE, STABILITY AND DISPOSAL.....	37
13	SPECIAL HANDLING INSTRUCTIONS.....	37
PART II: SCIENTIFIC INFORMATION		39
14	PHARMACEUTICAL INFORMATION	39
15	CLINICAL TRIALS	39
15.1	Trial Design and Study Demographics	39
15.2	Study Results.....	42
16	NON-CLINICAL TOXICOLOGY.....	53
PATIENT MEDICATION INFORMATION.....		57

PART I: HEALTH PROFESSIONAL INFORMATION

1 INDICATIONS

Victoza® is indicated for once-daily administration for the treatment of adults, with type 2 diabetes to improve glycemic control in combination with:

- diet and exercise in patients for whom metformin is inappropriate due to contraindication or intolerance.
- metformin, when diet and exercise plus maximal tolerated dose of metformin do not achieve adequate glycemic control.
- metformin and a sulfonylurea, when diet and exercise plus dual therapy with metformin and a sulfonylurea do not achieve adequate glycemic control.
- metformin and a sodium glucose cotransporter 2 inhibitor (SGLT2i), when diet and exercise plus dual therapy with metformin and a SGLT2i do not achieve adequate glycemic control.
- metformin and basal insulin, when diet and exercise plus dual therapy with Victoza® and metformin do not achieve adequate glycemic control (see CLINICAL TRIALS).

Add-on combination in patients with established cardiovascular disease: Victoza® is indicated as an adjunct to diet, exercise, and standard of care therapy to reduce the incidence of cardiovascular death in patients with type 2 diabetes mellitus and established cardiovascular disease (see CLINICAL TRIALS).

There is limited clinical experience with the combination of Victoza® and prandial (short-acting) insulin.

Victoza® is not a substitute for insulin. Victoza® should not be used in type 1 diabetes (formerly known as insulin-dependent diabetes mellitus or IDDM).

1.1 Pediatrics

Pediatrics (≥ 10 years of age): In adolescents and children aged 10 years and above with type 2 diabetes, Victoza® is indicated as an adjunct to metformin with or without basal insulin, when diet and exercise plus maximal tolerated dose of metformin do not achieve adequate glycemic control.

1.2 Geriatrics

Geriatrics (≥ 65 years of age): No overall difference in safety or efficacy was observed in clinical trial subjects' ≥ 65 years of age compared to younger patients, but greater sensitivity of older individuals cannot be ruled out (see WARNINGS AND PRECAUTIONS, Special Populations, Geriatrics; ADVERSE REACTIONS, Adverse Reaction Overview, Clinical Trial Adverse Drug Reactions, Gastrointestinal adverse events; and DOSAGE AND ADMINISTRATION, Recommended Dose and Dosage Adjustment, Geriatrics).

2 CONTRAINDICATIONS

- Liraglutide is contraindicated in patients who are hypersensitive to this drug or to any ingredient in the formulation, including any non-medicinal ingredient, or component of the container. For a complete listing, see DOSAGE FORMS, STRENGTHS, COMPOSITION AND PACKAGING.
- In patients with a personal or family history of medullary thyroid carcinoma or in patients with Multiple Endocrine Neoplasia syndrome type 2 (MEN 2).
- In pregnant or breastfeeding women.

3 SERIOUS WARNINGS AND PRECAUTIONS BOX

Serious Warnings and Precautions

Risk of Thyroid C-cell Tumours

- Liraglutide causes dose-dependent and treatment-duration-dependent thyroid C-cell tumours at clinically relevant exposures in both genders of rats and mice (See NON-CLINICAL TOXICOLOGY). It is unknown whether Victoza[®] causes thyroid C-cell tumours, including medullary thyroid carcinoma (MTC), in humans, as human relevance could not be ruled out by clinical or nonclinical studies.
- Victoza[®] is contraindicated in patients with a personal or family history of MTC and in patients with Multiple Endocrine Neoplasia syndrome type 2 (MEN 2). Based on the findings in rodents, monitoring with serum calcitonin or thyroid ultrasound was performed during clinical trials, but this may have increased the number of unnecessary thyroid surgeries. It is unknown whether monitoring with serum calcitonin or thyroid ultrasound will mitigate human risk of thyroid C-cell tumours. Patients should be counselled regarding the risk and symptoms of thyroid tumours. (see **CONTRAINDICATIONS, WARNINGS AND PRECAUTIONS, ADVERSE REACTIONS and NON-CLINICAL TOXICOLOGY**)

4 DOSAGE AND ADMINISTRATION

4.1 Dosing Considerations

For all patients Victoza[®] is administered once daily at any time, independent of meals. Victoza[®] should be initiated with a dose of 0.6 mg once daily for at least one week. The 0.6 mg dose is a starting dose intended to reduce gastrointestinal symptoms during initial titration. After one week at 0.6 mg per day, the dose should be increased to 1.2 mg once daily. Based on clinical response and after at least one week the dose can be increased to 1.8 mg once daily to achieve maximum efficacy for glycemc control.

Victoza® can be added to existing metformin therapy. The current dose of metformin can be continued unchanged at the discretion of the doctor.

Victoza® can be added to combined metformin and sulfonylurea therapy. During clinical trials doctors were advised, at their discretion, to lower the dose of sulfonylurea to minimize the risk of unacceptable hypoglycemia.

Victoza® can be added to combined metformin and SGLT2i therapy. The current dose of metformin and the SGLT2i can be continued unchanged at the discretion of the doctor.

When using Victoza® with insulin, administer as separate injections. Never mix. It is acceptable to inject Victoza® and insulin in the same body region but the injections should not be adjacent to each other.

In children and adolescents aged 10 years and above

Victoza® can be added to existing metformin therapy with or without basal insulin. The current dose of metformin can be continued unchanged at the discretion of the doctor. The current dose of basal insulin should be decreased at the discretion of the doctor. (See WARNINGS AND PRECAUTIONS, Monitoring and Laboratory Tests)

4.2 Recommended Dose and Dosage Adjustment

Renal Insufficiency: No dose adjustment is required for patients with mild, moderate or severe renal insufficiency (creatinine clearance 60-90 mL/min, 30-59 mL/min and < 30 mL/min respectively). There is very limited or no clinical experience with Victoza® in patients with end-stage renal disease; use of Victoza® in these patients is not recommended (see WARNINGS AND PRECAUTIONS, Special Populations; and ACTION AND CLINICAL PHARMACOLOGY, Special Populations and Conditions).

In the LEADER trial (see CLINICAL TRIALS), 3907 (41.8%) patients had mild renal impairment (eGFR 60 to 90 mL/min/1.73 m²), 1934 (20.7%) patients had moderate renal impairment (eGFR 30 to 60 mL/min/1.73 m²) and 224 (2.4%) patients had severe renal impairment (eGFR < 30 mL/min/1.73 m²) at baseline. No overall differences in safety or efficacy were seen in these patients compared to patients with normal renal function.

Hepatic Insufficiency: There is limited clinical experience in patients with mild, moderate or severe hepatic insufficiency. No dose adjustment is required for patients with hepatic impairment. (See ACTION AND CLINICAL PHARMACOLOGY, Special Populations and Conditions)

Geriatrics (>65 years of age): In the Victoza® clinical trials, a total of 797 (20%) of the patients were 65 years of age and over and 113 (2.8%) were 75 years of age and over. No overall difference in safety or efficacy were observed between these patients compared to younger patients, but greater sensitivity of older individuals cannot be ruled out.

In the LEADER trial, a total of 3493 (37.4%) of the patients were 65 to 74 years of age, 794 (8.5%) were 75 to 84 years of age, and 42 (0.4%) were 85 years of age or older at baseline. No overall difference in safety or efficacy was observed between these patients compared to younger patients (see WARNINGS AND PRECAUTIONS, Special Populations; ADVERSE REACTIONS, Clinical Trial Adverse Drug Reactions, Gastrointestinal adverse events; and

ACTION AND CLINICAL PHARMACOLOGY, Special Populations and Conditions).

Pediatrics (≥ 10 years of age): Victoza® should be initiated with a dose of 0.6 mg once daily for at least one week. The 0.6 mg dose is a starting dose intended to reduce gastrointestinal symptoms during initial titration. After one week at 0.6 mg per day, the dose may be increased to 1.2 mg once daily if additional glycemic control is required. Based on clinical response and after at least one week the dose may be increased to 1.8 mg once daily if additional glycemic control is required. (See WARNINGS AND PRECAUTIONS, Monitoring and Laboratory Tests)

No data are available for children below 10 years of age.

4.3 Administration

Victoza® is administered once daily at any time, independent of meals, and can be injected subcutaneously in the abdomen, in the thigh or in the upper arm. The injection site and timing can be changed if needed without dose adjustment.

4.4 Missed Dose

If a dose of Victoza® is missed take your dose on the next day as usual. Do not take an extra dose or increase the dose on the following day to make up for the missed dose.

5 OVERDOSAGE

From clinical trials and marketed use overdoses have been reported up to 40 times the recommended maintenance dose (72 mg). One case of a 10-fold overdose (18 mg daily) given for 7 months has been reported. All patients recovered without complications. The patients reported severe nausea, vomiting and diarrhea. Severe hypoglycemia has been observed.

In the event of overdosage, appropriate supportive treatment should be initiated according to the patient's clinical signs and symptoms. The patient should be observed for clinical signs of dehydration and blood glucose should be monitored.

For management of a suspected drug overdose, contact your regional poison control centre.

6 DOSAGE FORMS, STRENGTHS, COMPOSITION AND PACKAGING

Table – Dosage Forms, Strengths, Composition and Packaging

Route of Administration	Dosage Form / Strength/Composition	Non-medicinal Ingredients
subcutaneous	Injectable, 6 mg/mL	Disodium phosphate dihydrate, propylene glycol, phenol and water for injections.

Victoza® comes in a pre-filled disposable pen, comprising of a pen injector assembled with a cartridge (3 mL).

The cartridge is made of glass (type 1), containing a bromobutyl rubber closure shaped as a plunger and closed with a bromobutyl/polyisoprene rubber closure. The pen injector is made of

polyolefin and polyacetal. When incinerated these materials only result in non-toxic waste products (carbon dioxide and water).

Victoza[®] multidose pen can deliver 30 doses of 0.6 mg, 15 doses of 1.2 mg or 10 doses of 1.8 mg.

Pack sizes available:

Victoza[®] pen multidose (0.6, 1.2 or 1.8 mg): 1 pen (total supply 10 days), 2 pens (total supply 20 days) or 3 pens (total supply 30 days).

7 DESCRIPTION

Victoza[®] contains liraglutide, an analog of human GLP-1 and acts as a GLP-1 receptor agonist. The peptide precursor of liraglutide, produced by a process that includes expression of recombinant DNA in *Saccharomyces cerevisiae*, has been engineered to be 97% homologous to native human GLP-1 by substituting arginine for lysine at position 34. Liraglutide is made by attaching a C-16 fatty acid (palmitic acid) with a glutamic acid spacer on the remaining lysine residue at position 26 of the peptide precursor.

Victoza[®] is a clear, colorless solution. Each 1 mL of Victoza[®] solution contains 6 mg of liraglutide. Each pre-filled pen contains a 3 mL solution of Victoza[®] equivalent to 18 mg liraglutide (free-base, anhydrous).

8 WARNINGS AND PRECAUTIONS

General

Victoza[®] is not a substitute for insulin. Victoza[®] should not be used in patients with type 1 diabetes mellitus or for the treatment of diabetic ketoacidosis. Victoza[®] should not be administered intravenously or intramuscularly.

In children and adolescent with type 2 diabetes mellitus, concurrent use of Victoza[®] and prandial insulin has not been studied.

The Victoza[®] pen should never be shared between patients, even if the needle is changed. Sharing poses a risk for transmission of blood-borne pathogens.

Carcinogenesis and Mutagenesis

Risk of Thyroid C-Cell Tumours

Liraglutide causes dose-dependent and treatment-duration-dependent thyroid C-cell tumours (adenomas and/or carcinomas) at clinically relevant exposures in both genders of rats and mice (see NON-CLINICAL TOXICOLOGY). Malignant thyroid C-cell carcinomas were detected in rats and mice. It is unknown whether Victoza[®] will cause thyroid C-cell tumours, including medullary thyroid carcinoma (MTC), in humans, as the human relevance of liraglutide-induced rodent thyroid C-cell tumours could not be confirmed by clinical or nonclinical studies.

Cases of thyroid C-cell hyperplasia have been reported in clinical trials (see ADVERSE REACTIONS, Clinical Trial Adverse Drug Reactions). The data are insufficient to establish or exclude a causal relationship between thyroid C-cell tumours and Victoza[®] in humans.

Counsel patients regarding the risk for MTC and the symptoms of thyroid tumours (e.g. a mass in the neck, dysphagia, dyspnea or persistent hoarseness).

Victoza® is contraindicated in patients with a personal or family history of MTC or in patients with MEN 2. The clinical value of routine monitoring of serum calcitonin has not been established.

Cardiovascular

Increase in Heart Rate

A 24 h time-averaged increase in mean heart rate of 7 to 8 bpm was reported with Victoza® treatment in a clinical trial in healthy volunteers undergoing serial ECG monitoring (see ACTION AND CLINICAL PHARMACOLOGY, Cardiac Electrophysiology). In patients with diabetes, including patients with established and high risk for CV disease in the LEADER trial, a mean increase in heart rate from baseline of 2 to 4 beats per minute was observed with Victoza® in long-term clinical trials. The incidence of a composite endpoint for all tachyarrhythmia in pooled Phase 3a clinical trials in diabetic patients was higher for Victoza® than for placebo (see ADVERSE REACTIONS, Clinical Trial Adverse Drug Reactions, Cardiovascular).

PR Interval Prolongation

A prolongation of the mean PR interval of up to 10 ms was reported with Victoza® treatment in a clinical trial in healthy volunteers (see ACTION AND CLINICAL PHARMACOLOGY, Cardiac Electrophysiology). In healthy volunteers and in patients with diabetes, the incidence of first degree atrioventricular (AV) block was higher with Victoza® than with placebo (see ACTION AND CLINICAL PHARMACOLOGY, Cardiac Electrophysiology; ADVERSE REACTIONS, Cardiovascular). The clinical significance of these changes is not fully known; however, because of limited clinical experience in patients with pre-existing conduction system abnormalities (e.g., marked first-degree AV block or second- or third-degree AV block) and heart rhythm disturbances (e.g., tachyarrhythmia), caution should be observed in these patients (see DRUG INTERACTIONS).

Endocrine and Metabolism

Hypoglycemia

Patients receiving Victoza® in combination with a sulfonylurea or insulin may have an increased risk of hypoglycemia (see ADVERSE REACTIONS, Clinical Trial Adverse Reactions, Hypoglycemia). The risk of hypoglycemia can be lowered by reducing the dose of sulfonylurea or insulin (see ADVERSE REACTIONS, Clinical Trial Adverse Reactions Hypoglycemia; DOSAGE AND ADMINISTRATION, Dosing Considerations). Patients should be advised to take precautions to avoid hypoglycemia while driving and using machines, in particular when Victoza® is used in combination with a sulfonylurea or insulin.

In pediatric patients aged 10 years and above, the risk of hypoglycemia was higher with Victoza® in combination with metformin with or without basal insulin.

Pancreatitis

Based on spontaneous post-marketing reports, acute pancreatitis, including fatal and non-fatal hemorrhagic or necrotizing pancreatitis, has been observed in patients treated with Victoza® (see ADVERSE REACTIONS, Clinical Trial Adverse reactions, Pancreatitis). After initiation of Victoza® and after dose increases, observe patients carefully for signs and symptoms of pancreatitis (including persistent or intermittent severe abdominal pain, sometimes radiating to the back and which may or may not be accompanied by vomiting). If pancreatitis is suspected,

Victoza® and other potentially suspect medications should be discontinued promptly, confirmatory tests should be performed and appropriate management should be initiated. If pancreatitis is confirmed, Victoza® should not be restarted.

Victoza® has been studied in a limited number of patients with a history of pancreatitis. It is unknown if patients with a history of pancreatitis are at higher risk for development of pancreatitis on Victoza®.

8.1 Special Populations

8.1.1 Pregnant Women

There have been no studies conducted in pregnant women with Victoza®. Studies in animals have shown reproductive and developmental toxicity, including teratogenicity, at or above 0.8 times the clinical exposure (see NON-CLINICAL TOXICOLOGY).

Victoza® should not be used during pregnancy (see CONTRAINDICATIONS). If a patient wishes to become pregnant, or pregnancy occurs, treatment with liraglutide should be discontinued.

8.1.2 Breast-feeding

It is not known whether Victoza® is excreted in human milk. In lactating animals Victoza® was excreted unchanged in milk. Because many drugs are excreted in human milk and because of the potential for tumorigenicity shown for liraglutide in animal studies, women who are nursing should discontinue Victoza® treatment (see NON-CLINICAL TOXICOLOGY).

8.1.3 Pediatrics

Pediatrics (≥ 10 years of age): Victoza® can be used as an add-on to metformin with or without basal insulin in adolescents and children aged 10 years and above. The risk of hypoglycemia is higher in pediatric patients 10 years and above in combination with metformin with or without basal insulin. The safety and efficacy of Victoza® have not been established in children under 10 years of age.

8.1.4 Geriatrics

Geriatrics (>65 years of age): In the Victoza® treatment arm of the glycemic control trials, a total of 797 (20%) of the patients were 65 years of age and over, of which 113 (2.8%) were 75 years of age and over. No differences in safety and efficacy were observed between these patients and younger patients, but greater sensitivity of older individuals cannot be ruled out (see ADVERSE REACTIONS, Clinical Trial Adverse Reactions, Gastrointestinal adverse events and DOSAGE AND ADMINISTRATION, Recommended Dose and Dosage Adjustment, Geriatrics and ACTION AND CLINICAL PHARMACOLOGY, Special Populations and Conditions, Geriatrics (>65 years of age)).

8.1.5 Cardiovascular

Patients with recent MI or stroke, or severe congestive heart failure: In clinical trials of Victoza®, patients with acute myocardial infarction or stroke within 2 weeks of trial inclusion, and severe congestive heart failure (NYHA class IV) were not studied. Therefore, Victoza® should be used with caution in this population.

8.1.6 Hepatic Insufficiency

There is limited clinical experience in patients with mild, moderate or severe hepatic insufficiency. (See DOSAGE AND ADMINISTRATION, Recommended Dose and Dosage Adjustment, Hepatic insufficiency and ACTION AND CLINICAL PHARMACOLOGY, Special Population and Conditions, Hepatic insufficiency).

8.1.7 Renal Insufficiency

There have been post-marketing reports of acute renal failure and worsening of chronic renal failure, which may sometimes require hemodialysis in Victoza[®]-treated patients (see ADVERSE REACTIONS, Post-Market Adverse Drug Reactions). Some of these events were reported in patients without known underlying renal disease.

Patients treated with Victoza[®] should be advised of the potential risk of dehydration in relation to gastrointestinal side effects and take precautions to avoid fluid depletion. Renal insufficiency has been reported, usually in association with nausea, vomiting, diarrhea or dehydration which may sometimes require hemodialysis. Use caution in patients who experience dehydration (see ADVERSE REACTIONS).

8.1.8 Gastrointestinal Disease

The use of Victoza[®] is associated with transient gastrointestinal adverse reactions, including nausea, vomiting and diarrhea (see ADVERSE REACTIONS, Adverse Reaction Overview and Clinical Trial Adverse Drug Reactions, Gastrointestinal adverse events). The safety of Victoza[®] in subjects with inflammatory bowel disease and diabetic gastroparesis has not been studied. Victoza[®] should not be used in this population.

8.1.9 Hypersensitivity Reactions

There have been post-marketing reports of serious hypersensitivity reactions (e.g., anaphylactic reactions and angioedema) in patients treated with Victoza[®]. If a hypersensitivity reaction occurs, discontinue Victoza[®] and other suspect medications; treat promptly per standard of care, and monitor until signs and symptoms resolve. Do not use in patients with a previous hypersensitivity reaction to Victoza[®] (see CONTRAINDICATIONS).

Angioedema has also been reported with other GLP-1 receptor agonists. Use caution in a patient with a history of angioedema with another GLP-1 receptor agonist because it is unknown whether such patients will be predisposed to angioedema with Victoza[®].

8.1.10 Thyroid Disease

Thyroid adverse events, such as goitre, have been reported in clinical trials, in particular in patients with pre-existing thyroid disease. Victoza[®] should therefore be used with caution in these patients.

8.1.11 Acute Gallbladder Disease

In the LEADER trial, 3.1% of Victoza[®]-treated patients versus 1.9% of placebo-treated patients reported an acute event of gallbladder disease, such as cholelithiasis or cholecystitis. The majority of events required hospitalization or cholecystectomy. If cholelithiasis is suspected,

gallbladder studies and appropriate clinical follow-up are indicated.

8.2 Monitoring and Laboratory Tests

Regular self-monitoring of blood glucose is not needed in order to adjust the dose of Victoza[®]. However, when initiating treatment with Victoza[®] in combination with a sulfonylurea blood glucose self-monitoring may become necessary to reduce the dose of the sulfonylurea or insulin in order to reduce the risk of hypoglycemia.

In adolescents and children aged 10 years and above, due to the higher risks of hypoglycemia in pediatric patients with type 2 diabetes, additional blood glucose monitoring is recommended to reduce the risk of hypoglycemia especially asymptomatic hypoglycemia when Victoza[®] is added to metformin with or without basal insulin initially.

Patients should be informed that a response to all diabetic therapies should be monitored by periodic measurement of A1C levels, with a goal of decreasing these levels towards the normal range. A1C is especially useful for evaluating long-term glycemic control.

9 ADVERSE REACTIONS

9.1 Adverse Reaction Overview

A total of 12516 patients with type 2 diabetes have been treated with Victoza[®], alone or in combination with other antidiabetic agents, including basal insulin and pre-mix insulin, in glycemic control and cardiovascular outcome trials.

In glycemic control trials that were 26 weeks or longer in duration, the most common adverse drug reactions were nausea and diarrhea. Serious adverse events occurred in a similar proportion of patients treated with Victoza[®] (5.7%) as compared to other study treatments (5.6%), most commonly cardiac disorders (see ADVERSE REACTIONS, Clinical Trial Adverse Reactions, Cardiovascular). Discontinuation of treatment due to adverse events was more common with Victoza[®] (7.8%) as compared to comparator treatments (3.4%). The difference was driven by withdrawals due to gastrointestinal disorders with 2.8% and 1.5% of Victoza[®] treated patients discontinuing due to nausea and vomiting, respectively.

9.2 Clinical Trial Adverse Reactions

Because clinical trials are conducted under very specific conditions, the adverse reaction rates observed in the clinical trials may not reflect the rates observed in practice and should not be compared to the rates in the clinical trials of another drug. Adverse reaction information from clinical trials is useful for identifying drug-related adverse events and for approximating rates.

Table 1 provides a listing of the treatment-emergent adverse events with frequency $\geq 1\%$ from two 26-week combination trials 1572 and 1697 regardless of investigator assessment of causality. The two 26-week controlled clinical studies of Victoza[®] were LEAD[™] 2 - 1572 for add on combination therapy with metformin and LEAD[™] 5 – 1697 for add on combination therapy with metformin + sulfonylurea (see CLINICAL TRIALS).

Table 1 Treatment-emergent adverse events from two 26-week combination trials 1572 and 1697

	Trial 1572 (LEAD™ 2)					Trial 1697 (LEAD™ 5)		
	Victoza® 0.6 mg + metformin	Victoza® 1.2 mg + metformin	Victoza® 1.8 mg + metformin	Placebo + metformin	Active Comparator (metformin + glimepiride)	Victoza® 1.8 mg + metformin + glimepiride	Placebo + metformin + glimepiride	Active Comparator (insulin glargine + metformin + glimepiride)
System Organ Class Preferred Term	N (%)	N (%)	N (%)	N (%)	N (%)	N (%)	N (%)	N (%)
Safety Analysis Set	242	240	242	121	242	230	114	232
Blood and Lymphatic System Disorders								
Anemia	4 (1.7)	1 (0.4)	1 (0.4)	0 (0.0)	2 (0.8)	1 (0.4)	0 (0.0)	0 (0.0)
Ear and Labyrinth Disorders								
Vertigo	1 (0.4)	1 (0.4)	3 (1.2)	0 (0.0)	2 (0.8)	3 (1.3)	0 (0.0)	1 (0.4)
Motion Sickness	1 (0.4)	1 (0.4)	0 (0.0)	0 (0.0)	2 (0.8)	0 (0.0)	2 (1.8)	0 (0.0)
Eye Disorders								
Diabetic retinopathy	5 (2.1)	4 (1.7)	5 (2.1)	1 (0.8)	8 (3.3)	2 (0.9)	3 (2.6)	4 (1.7)
Cataract	3 (1.2)	2 (0.8)	3 (1.2)	2 (1.7)	1 (0.4)	1 (0.4)	0 (0.0)	2 (0.9)
Conjunctivitis	0 (0.0)	3 (1.3)	2 (0.8)	1 (0.8)	0 (0.0)	0 (0.0)	0 (0.0)	0 (0.0)
Arteriosclerotic retinopathy	0 (0.0)	1 (0.4)	0 (0.0)	2 (1.7)	2 (0.8)	0 (0.0)	0 (0.0)	0 (0.0)
Injury, Poisoning and Procedural Complications								
Soft tissue injury	0 (0.0)	0 (0.0)	0 (0.0)	0 (0.0)	3 (1.2)	0 (0.0)	0 (0.0)	0 (0.0)
Fall	1 (0.4)	1 (0.4)	0 (0.0)	0 (0.0)	2 (0.8)	0 (0.0)	2 (1.8)	1 (0.4)
Gastrointestinal Disorders								
Nausea	26 (10.7)	39 (16.3)	45 (18.6)	5 (4.1)	8 (3.3)	32 (13.9)	4 (3.5)	3 (1.3)
Diarrhea	23 (9.5)	20 (8.3)	36 (14.9)	5 (4.1)	9 (3.7)	23 (10.0)	6 (5.3)	3 (1.3)
Vomiting	13 (5.4)	16 (6.7)	18 (7.4)	1 (0.8)	1 (0.4)	15 (6.5)	4 (3.5)	1 (0.4)
Dyspepsia	9 (3.7)	5 (2.1)	17 (7.0)	1 (0.8)	3 (1.2)	15 (6.5)	1 (0.9)	4 (1.7)
Gastritis	8 (3.3)	6 (2.5)	12 (5.0)	1 (0.8)	2 (0.8)	3 (1.3)	0 (0.0)	1 (0.4)
Abdominal pain upper	5 (2.1)	7 (2.9)	8 (3.3)	0 (0.0)	3 (1.2)	10 (4.3)	2 (1.8)	2 (0.9)
Toothache	2 (0.8)	6 (2.5)	3 (1.2)	5 (4.1)	2 (0.8)	5 (2.2)	0 (0.0)	3 (1.3)
Abdominal pain	2 (0.8)	4 (1.7)	6 (2.5)	2 (1.7)	1 (0.4)	2 (0.9)	1 (0.9)	1 (0.4)
Constipation	5 (2.1)	11 (4.6)	6 (2.5)	2 (1.7)	4 (1.7)	5 (2.2)	0 (0.0)	2 (0.9)
Abdominal discomfort	3 (1.2)	2 (0.8)	3 (1.2)	0 (0.0)	2 (0.8)	3 (1.3)	2 (1.8)	1 (0.4)
Abdominal distension	2 (0.8)	2 (0.8)	2 (0.8)	0 (0.0)	4 (1.7)	3 (1.3)	1 (0.9)	1 (0.4)
Epigastric discomfort	2 (0.8)	2 (0.8)	3 (1.2)	0 (0.0)	0 (0.0)	0 (0.0)	0 (0.0)	0 (0.0)
Gastrointestinal disorder	2 (0.8)	2 (0.8)	3 (1.2)	0 (0.0)	0 (0.0)	2 (0.9)	0 (0.0)	0 (0.0)
Gastroesophageal reflux disease	4 (1.7)	2 (0.8)	1 (0.4)	0 (0.0)	0 (0.0)	1 (0.4)	0 (0.0)	0 (0.0)

	Trial 1572 (LEAD™ 2)					Trial 1697 (LEAD™ 5)		
	Victoza® 0.6 mg + metformin	Victoza® 1.2 mg + metformin	Victoza® 1.8 mg + metformin	Placebo + metformin	Active Comparator (metformin + glimepiride)	Victoza® 1.8 mg + metformin + glimepiride	Placebo + metformin + glimepiride	Active Comparator (insulin glargine + metformin + glimepiride)
System Organ Class Preferred Term	N (%)	N (%)	N (%)	N (%)	N (%)	N (%)	N (%)	N (%)
General Disorders and Administration Site Conditions								
Fatigue	3 (1.2)	5 (2.1)	6 (2.5)	2 (1.7)	3 (1.2)	1 (0.4)	0 (0.0)	0 (0.0)
Asthenia	2 (0.8)	2 (0.8)	3 (1.2)	0 (0.0)	3 (1.2)	1 (0.4)	1 (0.9)	0 (0.0)
Influenza like illness	2 (0.8)	0 (0.0)	0 (0.0)	1 (0.8)	3 (1.2)	1 (0.4)	1 (0.9)	0 (0.0)
Early satiety	1 (0.4)	3 (1.3)	1 (0.4)	0 (0.0)	0 (0.0)	1 (0.4)	0 (0.0)	0 (0.0)
Chest pain	0 (0.0)	3 (1.3)	0 (0.0)	0 (0.0)	2 (0.8)	0 (0.0)	1 (0.9)	1 (0.4)
Pyrexia	1 (0.4)	3 (1.3)	0 (0.0)	0 (0.0)	1 (0.4)	5 (2.2)	1 (0.9)	5 (2.2)
Hepatobiliary Disorders								
Hepatic steatosis	6 (2.5)	2 (0.8)	1 (0.4)	0 (0.0)	4 (1.7)	0 (0.0)	0 (0.0)	0 (0.0)
Immune System Disorders								
Seasonal allergy	2 (0.8)	3 (1.3)	0 (0.0)	0 (0.0)	2 (0.8)	0 (0.0)	0 (0.0)	0 (0.0)
Infections and Infestations								
Nasopharyngitis	27 (11.2)	21 (8.8)	21 (8.7)	11 (9.1)	30 (12.4)	21 (9.1)	10 (8.8)	26 (11.2)
Influenza	5 (2.1)	1 (0.4)	8 (3.3)	2 (1.7)	8 (3.3)	2 (0.9)	5 (4.4)	8 (3.4)
Pharyngitis	2 (0.8)	2 (0.8)	2 (0.8)	0 (0.0)	1 (0.4)	2 (0.9)	5 (4.4)	2 (0.9)
Upper respiratory tract infection	4 (1.7)	8 (3.3)	5 (2.1)	3 (2.5)	3 (1.2)	2 (0.9)	0 (0.0)	2 (0.9)
Acute tonsillitis	1 (0.4)	0 (0.0)	0 (0.0)	0 (0.0)	1 (0.4)	1 (0.4)	0 (0.0)	3 (1.3)
Lower respiratory tract infection	0 (0.0)	0 (0.0)	0 (0.0)	1 (0.8)	1 (0.4)	1 (0.4)	1 (0.9)	3 (1.3)
Bronchitis	5 (2.1)	9 (3.8)	4 (1.7)	1 (0.8)	9 (3.7)	7 (3.0)	1 (0.9)	3 (1.3)
Respiratory tract infection	0 (0.0)	0 (0.0)	4 (1.7)	0 (0.0)	1 (0.4)	0 (0.0)	1 (0.9)	1 (0.4)
Gastroenteritis	6 (2.5)	4 (1.7)	3 (1.2)	2 (1.7)	4 (1.7)	3 (1.3)	1 (0.9)	3 (1.3)
Urinary tract infection	3 (1.2)	5 (2.1)	3 (1.2)	3 (2.5)	3 (1.2)	3 (1.3)	2 (1.8)	3 (1.3)
Tooth abscess	0 (0.0)	0 (0.0)	3 (1.2)	1 (0.8)	1 (0.4)	0 (0.0)	0 (0.0)	1 (0.4)
Pneumonia	1 (0.4)	3 (1.3)	2 (0.8)	1 (0.8)	3 (1.2)	0 (0.0)	2 (1.8)	3 (1.3)
Onychomycosis	3 (1.2)	1 (0.4)	1 (0.4)	0 (0.0)	1 (0.4)	0 (0.0)	0 (0.0)	0 (0.0)
Sinusitis	4 (1.7)	4 (1.7)	1 (0.4)	0 (0.0)	2 (0.8)	0 (0.0)	2 (1.8)	3 (1.3)
Viral infection	2 (0.8)	1 (0.4)	1 (0.4)	0 (0.0)	1 (0.4)	3 (1.3)	1 (0.9)	2 (0.9)
Investigations								
Weight decreased	0 (0.0)	2 (0.8)	4 (1.7)	0 (0.0)	0 (0.0)	0 (0.0)	0 (0.0)	0 (0.0)
Blood creatine phosphokinase increased	2 (0.8)	3 (1.3)	2 (0.8)	1 (0.8)	4 (1.7)	2 (0.9)	0 (0.0)	0 (0.0)
Blood calcitonin increased	3 (1.2)	1 (0.4)	1 (0.4)	3 (2.5)	2 (0.8)	3 (1.3)	0 (0.0)	0 (0.0)
Urine albumin / creatinine ratio increased	2 (0.8)	1 (0.4)	0 (0.0)	2 (1.7)	1 (0.4)	1 (0.4)	0 (0.0)	0 (0.0)
Blood pressure increased	0 (0.0)	1 (0.4)	0 (0.0)	2 (1.7)	0 (0.0)	0 (0.0)	0 (0.0)	0 (0.0)

	Trial 1572 (LEAD™ 2)					Trial 1697 (LEAD™ 5)		
	Victoza® 0.6 mg + metformin	Victoza® 1.2 mg + metformin	Victoza® 1.8 mg + metformin	Placebo + metformin	Active Comparator (metformin + glimepiride)	Victoza® 1.8 mg + metformin + glimepiride	Placebo + metformin + glimepiride	Active Comparator (insulin glargine + metformin + glimepiride)
System Organ Class Preferred Term	N (%)	N (%)	N (%)	N (%)	N (%)	N (%)	N (%)	N (%)
Metabolism and Nutrition Disorders								
Anorexia Decreased appetite	6 (2.5)	10 (4.2)	14 (5.8)	1 (0.8)	1 (0.4)	10 (4.3)	1 (0.9)	0 (0.0)
Dyslipidemia	4 (1.7)	14 (5.8)	10 (4.1)	0 (0.0)	0 (0.0)	2 (0.9)	1 (0.9)	0 (0.0)
Hyperlipidaemia	2 (0.8)	2 (0.8)	2 (0.8)	2 (1.7)	2 (0.8)	3 (1.3)	3 (2.6)	1 (0.4)
Hyperglycaemia	1 (0.4)	1 (0.4)	1 (0.4)	3 (2.5)	3 (1.2)	1 (0.4)	1 (0.9)	2 (0.9)
	1 (0.4)	0 (0.0)	1 (0.4)	3 (2.5)	0 (0.0)	2 (0.9)	0 (0.0)	0 (0.0)
Musculoskeletal and Connective Tissue Disorders								
Back pain	7 (2.9)	5 (2.1)	6 (2.5)	4 (3.3)	9 (3.7)	7 (3.0)	3 (2.6)	8 (3.4)
Arthralgia	6 (2.5)	0 (0.0)	3 (1.2)	3 (2.5)	7 (2.9)	4 (1.7)	3 (2.6)	6 (2.6)
Muscle spasms	5 (2.1)	0 (0.0)	2 (0.8)	3 (2.5)	3 (1.2)	2 (0.9)	3 (2.6)	3 (1.3)
Pain in extremity	0 (0.0)	2 (0.8)	7 (2.9)	1 (0.8)	2 (0.8)	1 (0.4)	1 (0.9)	0 (0.0)
Musculoskeletal pain	3 (1.2)	1 (0.4)	3 (1.2)	3 (2.5)	1 (0.4)	3 (1.3)	2 (1.8)	4 (1.7)
Osteoarthritis	3 (1.2)	1 (0.4)	1 (0.4)	2 (1.7)	2 (0.8)	0 (0.0)	1 (0.9)	2 (0.9)
Myalgia	1 (0.4)	3 (1.3)	4 (1.7)	2 (1.7)	4 (1.7)	0 (0.0)	1 (0.9)	3 (1.3)
Neck pain	1 (0.4)	1 (0.4)	0 (0.0)	1 (0.8)	3 (1.2)	3 (1.3)	0 (0.0)	1 (0.4)
Nervous System Disorders								
Headache	13 (5.4)	22 (9.2)	30 (12.4)	8 (6.6)	23 (9.5)	22 (9.6)	9 (7.9)	13 (5.6)
Dizziness	5 (2.1)	7 (2.9)	5 (2.1)	1 (0.8)	2 (0.8)	3 (1.3)	2 (1.8)	1 (0.4)
Sciatica	3 (1.2)	2 (0.8)	1 (0.4)	0 (0.0)	1 (0.4)	0 (0.0)	0 (0.0)	1 (0.4)
Psychiatric Disorders								
Anxiety	0 (0.0)	1 (0.4)	4 (1.7)	0 (0.0)	0 (0.0)	1 (0.4)	3 (2.6)	0 (0.0)
Depression	0 (0.0)	4 (1.7)	3 (1.2)	0 (0.0)	3 (1.2)	2 (0.9)	3 (2.6)	0 (0.0)
Insomnia	0 (0.0)	2 (0.8)	3 (1.2)	1 (0.8)	0 (0.0)	1 (0.4)	0 (0.0)	0 (0.0)
Respiratory, Thoracic and Mediastinal Disorders								
Pharyngolaryngeal pain	3 (1.2)	4 (1.7)	2 (0.8)	1 (0.8)	3 (1.2)	2 (0.9)	2 (1.8)	1 (0.4)
Cough	4 (1.7)	3 (1.3)	2 (0.8)	1 (0.8)	5 (2.1)	4 (1.7)	1 (0.9)	7 (3.0)
Skin and Subcutaneous Tissue Disorders								
Pruritus	2 (0.8)	3 (1.3)	1 (0.4)	0 (0.0)	3 (1.2)	0 (0.0)	0 (0.0)	1 (0.4)
Rash	0 (0.0)	1 (0.4)	1 (0.4)	1 (0.8)	3 (1.2)	3 (1.3)	0 (0.0)	2 (0.9)
Hyperhidrosis	1 (0.4)	0 (0.0)	1 (0.4)	2 (1.7)	1 (0.4)	1 (0.4)	0 (0.0)	0 (0.0)
Vascular Disorders								
Hypertension	5 (2.1)	7 (2.9)	5 (2.1)	2 (1.7)	6 (2.5)	7 (3.0)	3 (2.6)	5 (2.2)
Vascular calcification	2 (0.8)	2 (0.8)	1 (0.4)	1 (0.8)	3 (1.2)	0 (0.0)	0 (0.0)	0 (0.0)
Aortic calcification	2 (0.8)	0 (0.0)	1 (0.4)	0 (0.0)	3 (1.2)	0 (0.0)	0 (0.0)	0 (0.0)

	Trial 1572 (LEAD™ 2)					Trial 1697 (LEAD™ 5)		
	Victoza® 0.6 mg + metformin	Victoza® 1.2 mg + metformin	Victoza® 1.8 mg + metformin	Placebo + metformin	Active Comparator (metformin + glimepiride)	Victoza® 1.8 mg + metformin + glimepiride	Placebo + metformin + glimepiride	Active Comparator (insulin glargine + metformin + glimepiride)
System Organ Class Preferred Term	N (%)	N (%)	N (%)	N (%)	N (%)	N (%)	N (%)	N (%)
Arteriosclerosis	3 (1.2)	0 (0.0)	1 (0.4)	0 (0.0)	0 (0.0)	0 (0.0)	0 (0.0)	1 (0.4)
Hematoma	3 (1.2)	0 (0.0)	1 (0.4)	0 (0.0)	1 (0.4)	0 (0.0)	0 (0.0)	0 (0.0)

Table 2 provides a listing of the treatment-emergent adverse events with frequency $\geq 1\%$ from the 26-week trial NN2211-1860 regardless of investigator assessment of causality. The controlled clinical study of Victoza® was with add on metformin combination therapy (see CLINICAL TRIALS).

Table 2 Treatment-Emergent Adverse Events in trial 1860

	Victoza® 1.2 mg + metformin N= 221	Victoza® 1.8 mg + metformin N= 218	Sitagliptin 100 mg + metformin N= 219
System Organ Class Preferred Term	N (%)	N (%)	N (%)
Gastrointestinal Disorders			
Nausea	46 (20.8)	59 (27.1)	10(4.6)
Diarrhea	16 (7.2)	25 (11.5)	10 (4.6)
Vomiting	17 (7.7)	21 (9.6)	9 (4.1)
Dyspepsia	7 (3.2)	14 (6.4)	5 (2.3)
Constipation	10 (4.5)	11 (5.0)	6 (2.7)
Flatulence	2 (0.9)	5 (2.3)	1 (0.5)
Gastroesophageal Reflux Disease	3 (1.4)	5 (2.3)	2 (0.9)
Abdominal Distension	2 (0.9)	4 (1.8)	1 (0.5)
Abdominal Pain upper	5 (2.3)	4 (1.8)	2 (0.9)
Abdominal Discomfort	5 (2.3)	3 (1.4)	3 (1.4)
Abdominal Pain	5 (2.3)	2 (0.9)	6 (2.7)
Infections and Infestations			
Nasopharyngitis	21 (9.5)	28 (12.8)	26 (11.9)
Rhinitis	1 (0.5)	8 (3.7)	2 (0.9)
Upper Respiratory Tract Infection	10 (4.5)	7 (3.2)	8 (3.7)
Bronchitis	3 (1.4)	3 (1.4)	5 (2.3)
Gastroenteritis	2 (0.9)	3 (1.4)	2 (0.9)
Sinusitis	4 (1.8)	3 (1.4)	4 (1.8)
Influenza	13 (5.9)	2 (0.9)	5 (2.3)
Pharyngitis	1 (0.5)	2 (0.9)	3 (1.4)
Urinary Tract Infection	4 (1.8)	1 (0.5)	2 (0.9)
Lower Respiratory Tract Infection	0 (0.0)	0 (0.0)	3 (1.4)
Nervous System Disorders			
Headache	20 (9.0)	25 (11.5)	22 (10.0)
Dizziness	8 (3.6)	9 (4.1)	6 (2.7)
Diabetic neuropathy	1 (0.5)	3 (1.4)	1 (0.5)
Hypoaesthesia	2 (0.9)	0 (0.0)	3 (1.4)
Musculoskeletal and connective tissue disorders			

	Victoza® 1.2 mg + metformin N= 221	Victoza® 1.8 mg + metformin N= 218	Sitagliptin 100 mg + metformin N= 219
System Organ Class Preferred Term	N (%)	N (%)	N (%)
Back pain	8 (3.6)	8 (3.7)	10 (4.6)
Muscle spasms	3 (1.4)	4 (1.8)	0 (0.0)
Myalgia	0 (0.0)	4 (1.8)	5 (2.3)
Pain in extremity	1 (0.5)	4 (1.8)	5 (2.3)
Arthralgia	5 (2.3)	3 (1.4)	6 (2.7)
Musculoskeletal pain	2 (0.9)	3 (1.4)	3 (1.4)
Tendonitis	4 (1.8)	1 (0.5)	0 (0.0)
General disorders and administration site conditions			
Fatigue	7 (3.2)	9 (4.1)	1 (0.5)
Injection site hematoma	5 (2.3)	6 (2.8)	0 (0.0)
Metabolism and Nutrition Disorders			
Decreased appetite	7 (3.2)	12 (5.5)	2 (0.9)
Anorexia	8 (3.6)	6 (2.8)	1 (0.5)
Dyslipidaemia	4 (1.8)	1 (0.5)	4 (1.8)
Hyperglycemia	0 (0.0)	1 (0.5)	3 (1.4)
Hyperlipidemia	0 (0.0)	1 (0.5)	3 (1.4)
Investigations			
Blood calcitonin increased	6 (2.7)	9 (4.1)	5 (2.3)
C-reactive protein increased	2 (0.9)	2 (0.9)	4 (1.8)
Weight decreased	4 (1.8)	2 (0.9)	0 (0.0)
Respiratory, thoracic and mediastinal disorders			
Oropharyngeal pain	1 (0.5)	5 (2.3)	3 (1.4)
Cough	4 (1.8)	2 (0.9)	3 (1.4)
Nasal Congestion	0 (0.0)	0 (0.0)	4 (1.8)
Injury, Poisoning and procedural complications			
Contusion	3 (1.4)	3 (1.4)	3 (1.4)
Skin and subcutaneous tissue disorders			
Rash	4 (1.8)	3 (1.4)	2 (0.9)
Hyperhidrosis	3 (1.4)	1 (0.5)	2 (0.9)
Vascular disorders			
Hypertension	5 (2.3)	10 (4.6)	5 (2.3)
Cardiac Disorders			
Palpitations	3 (1.4)	0 (0.0)	0 (0.0)
Eye Disorders			
Diabetic retinopathy	3 (1.4)	2 (0.9)	1 (0.5)
Psychiatric disorders			
Insomnia	3 (1.4)	2 (0.9)	1 (0.5)
Endocrine disorders			
Goitre	2 (0.9)	1 (0.5)	4 (1.8)

Table 3 provides a listing of the treatment-emergent adverse events with frequency $\geq 1\%$ from the 52-week trial NN2211-1842 (main and extension) regardless of investigator assessment of causality. NN2211-1842 is the controlled clinical study of Victoza® 1.8 mg and intensification with insulin detemir (see CLINICAL TRIALS).

**Table 3 Treatment-Emergent Adverse Events in trial 1842 (main and extension)
(Adverse events with frequency ≥ 1 %)**

	Victoza® 1.8 mg + metformin N= 159	Levemir® (insulin detemir) + Victoza® 1.8 mg N= 163	Non-randomized N= 499
System Organ Class Preferred Term	N (%)	N (%)	N (%)
Infections and infestations			
Nasopharyngitis	32 (20.1)	23 (14.1)	48 (9.6)
Upper Respiratory Tract Infection	6 (3.8)	8 (4.9)	20 (4.0)
Influenza	6 (3.8)	5 (3.1)	11 (2.2)
Bronchitis	1 (0.6)	6 (3.7)	6 (1.2)
Gastroenteritis Viral	2 (1.3)	5 (3.1)	5 (1.0)
Urinary Tract Infection	2 (1.3)	4 (2.5)	11 (2.2)
Lower Respiratory Tract Infection	0 (0.0)	3 (1.8)	0 (0.0)
Tooth Infection	1 (0.6)	3 (1.8)	3 (0.6)
Sinusitis	1 (0.6)	1 (0.6)	8 (1.6)
Gastroenteritis	2 (1.3)	2 (1.2)	5 (1.0)
Viral Upper Respiratory Tract Infection	2 (1.3)	1 (0.6)	0 (0.0)
Sialoadentis	0 (0.0)	2 (1.2)	0 (0.0)
Tooth Abscess	0 (0.0)	2 (1.2)	3 (0.6)
Viral Infection	1 (0.6)	2 (1.2)	3 (0.6)
Cystitis	1 (0.6)	0 (0.0)	5 (1.0)
Gastrointestinal disorders			
Diarrhoea	12 (7.5)	19 (11.7)	21 (4.2)
Nausea	10 (6.3)	6 (3.7)	17 (3.4)
Vomiting	5 (3.1)	8 (4.9)	15 (3.0)
Abdominal Pain Upper	3 (1.9)	6 (3.7)	4 (0.8)
Constipation	4 (2.5)	5 (3.1)	8 (1.6)
Dyspepsia	3 (1.9)	5 (3.1)	9 (1.8)
Haemorrhoids	0 (0.0)	4 (2.5)	0 (0.0)
Toothache	1 (0.6)	4 (2.5)	8 (1.6)
Abdominal Pain	3 (1.9)	2 (1.2)	5 (1.0)
Abdominal Distension	0 (0.0)	3 (1.8)	3 (0.6)
Abdominal Discomfort	2 (1.3)	1 (0.6)	2 (0.4)
Gastroesophageal Reflux Disease	2 (1.3)	1 (0.6)	2 (0.4)
Abdominal Hernia	1 (0.6)	2 (1.2)	0 (0.0)
Investigations			
Lipase increased	5 (3.1)	18 (11.0)	20 (4.0)
Blood Amylase Increased	2 (1.3)	4 (2.5)	7 (1.4)
Blood Creatine Phosphokinase Increased	3 (1.9)	2 (1.2)	4 (0.8)
White Blood Cell Count Increased	0 (0.0)	3 (1.8)	1 (0.2)
Blood Urea Increased	2 (1.3)	0 (0.0)	0 (0.0)
Alanine Aminotransferase Increased	0 (0.0)	2 (1.2)	1 (0.2)
Blood Calcitonin Increased	0 (0.0)	0 (0.0)	6 (1.2)
General disorders and administration site conditions			
Fatigue	3 (1.9)	6 (3.7)	2 (0.4)
Injection site hematoma	3 (1.9)	4 (2.5)	5 (1.0)
Injection site reaction	0 (0.0)	4 (2.5)	0 (0.0)
Pyrexia	2 (1.3)	3 (1.8)	0 (0.0)
Influenza like illness	1 (0.6)	2 (1.2)	5 (1.0)
Malaise	1 (0.6)	2 (1.2)	1 (0.2)
Injury, poisoning and procedural			

	Victoza® 1.8 mg + metformin N= 159	Levemir® (insulin detemir) + Victoza® 1.8 mg N= 163	Non-randomized N= 499
System Organ Class Preferred Term	N (%)	N (%)	N (%)
complications			
Incorrect Dose Administered	1 (0.6)	4 (2.5)	1 (0.2)
Fall	2 (1.3)	2 (1.2)	5 (1.0)
Skin Laceration	2 (1.3)	0 (0.0)	1 (0.2)
Nervous system disorders			
Headache	13 (8.2)	10 (6.1)	28 (5.6)
Dizziness	2 (1.3)	3 (1.8)	4 (0.8)
Lethargy	1 (0.6)	3 (1.8)	
Skin and subcutaneous tissue disorders			
Pruritus	4 (2.5)	3 (1.8)	2 (0.4)
Rash	3 (1.9)	3 (1.8)	4 (0.8)
Alopecia	2 (1.3)	3 (1.8)	1 (0.2)
Hyperhidrosis	0 (0.0)	3 (1.8)	2 (0.4)
Eczema	0 (0.0)	0 (0.0)	5 (1.0)
Respiratory, thoracic and mediastinal disorders			
Oropharyngeal Pain	7 (4.4)	4 (2.5)	7 (1.4)
Cough	3 (1.9)	5 (3.1)	4 (0.8)
Dyspnoea	2 (1.3)	0 (0.0)	6 (1.2)
Epistaxis	2 (1.3)	0 (0.0)	3 (0.6)
Asthma	0 (0.0)	2 (1.2)	0 (0.0)
Dysphonia	0 (0.0)	2 (1.2)	0 (0.0)
Nasal Congestion	1 (0.6)	2 (1.2)	0 (0.0)
Musculoskeletal and connective tissue disorders			
Back Pain	5 (3.1)	3 (1.8)	6 (1.2)
Arthralgia	3 (1.9)	3 (1.8)	7 (1.4)
Pain in Extremity	2 (1.3)	2 (1.2)	3 (0.6)
Myalgia	2 (1.3)	2 (1.2)	1 (0.2)
Psychiatric disorders			
Depression	2 (1.3)	3 (1.8)	6 (1.2)
Insomnia	2 (1.3)	3 (1.8)	7 (1.4)
Anxiety	1 (0.6)	2 (1.2)	3 (0.6)
Stress	0 (0.0)	2 (1.2)	1 (0.2)
Eye disorders			
Diabetic Retinopathy	1 (0.6)	2 (1.2)	4 (0.8)
Vascular disorders			
Hypertension	3 (1.9)	2 (1.2)	13 (2.6)
Metabolism and nutrition disorders			
Decreased Appetite	1 (0.6)	2 (1.2)	4 (0.8)
Reproductive system and breast disorders			
Erectile dysfunction	1 (0.6)	2 (1.2)	3 (0.6)
Cardiac disorders			
Atrioventricular Block First Degree	0 (0.0)	2 (1.2)	2 (0.4)
Ear and labyrinth disorders			
Ear Pain	3 (1.9)	1 (0.6)	1 (0.2)
Tinnitus	2 (1.3)	0 (0.0)	1 (0.2)
Hepatobiliary disorders			
Hepatic Steatosis	0 (0.0)	2 (1.2)	5 (1.0)

	Victoza® 1.8 mg + metformin N= 159	Levemir® (insulin detemir) + Victoza® 1.8 mg N= 163	Non-randomized N= 499
System Organ Class Preferred Term	N (%)	N (%)	N (%)
Blood and lymphatic system disorders Anaemia	1 (0.6)	2 (1.2)	2 (0.4)

Table 4 provides a listing of the treatment-emergent adverse events, regardless of investigator assessment of causality, with a frequency > 5% from a 52-week active-controlled monotherapy trial (Trial 1573; LEAD™ 3) with a mean duration of exposure of 289, 280, and 274 days, in the Victoza® 1.8 mg, Victoza® 1.2 mg and glimepiride 8 mg treatment groups, respectively (see CLINICAL TRIALS).

Table 4 Treatment Emergent Adverse Events (> 5%) by System Organ Class and Preferred Term Safety Population (1573)

	Liraglutide 1.8 mg N=246	Liraglutide 1.2 mg N=251	Glimepiride N=248
System Organ Class Preferred Term	N (%)	N (%)	N (%)
Gastrointestinal Disorders	126 (51.2)	122 (48.6)	64 (25.8)
Constipation	28 (11.4)	21 (8.4)	12 (4.8)
Diarrhea	46 (18.7)	39 (15.5)	22 (8.9)
Flatulence	13 (5.3)	4 (1.6)	4 (1.6)
Nausea	72 (29.3)	69 (27.5)	21 (8.5)
Vomiting	23 (9.3)	31 (12.4)	9 (3.6)
General Disorders and Administration Site Conditions	41 (16.7)	33 (13.1)	37 (14.9)
Infections and Infestations	102 (41.5)	119 (47.4)	90 (36.3)
Influenza	20 (8.1)	17 (6.8)	9 (3.6)
Nasopharyngitis	9 (3.7)	17 (6.8)	13 (5.2)
Sinusitis	13 (5.3)	15 (6.0)	15 (6.0)
Upper Respiratory Tract Infection	24 (9.8)	23 (9.2)	14 (5.6)
Urinary Tract Infection	10 (4.1)	20 (8.0)	10 (4.0)
Injury, Poisoning and Procedural Complications	24 (9.8)	22 (8.8)	29 (11.7)
Investigations	23 (9.3)	16 (6.4)	18 (7.3)
Metabolism and Nutrition Disorders	35 (14.2)	38 (15.1)	28 (11.3)
Musculoskeletal and Connective Tissue Disorders	46 (18.7)	48 (19.1)	38 (15.3)
Back Pain	11 (4.5)	14 (5.6)	11 (4.4)
Nervous System Disorders	49 (19.9)	56 (22.3)	55 (22.2)
Dizziness	16 (6.5)	13 (5.2)	13 (5.2)
Headache	18 (7.3)	27 (10.8)	23 (9.3)
Psychiatric Disorders	21 (8.5)	21 (8.4)	14 (5.6)
Respiratory, Thoracic and Mediastinal Disorders	28 (11.4)	21 (8.4)	28 (11.3)
Skin and Subcutaneous Tissue Disorders	24 (9.8)	23 (9.2)	17 (6.9)
Vascular Disorders	15 (6.1)	11 (4.4)	17 (6.9)
Hypertension	8 (3.3)	7 (2.8)	15 (6.0)

Table 5 Adverse Events (≥1%) by System Organ Class and Preferred Term (LEADER EX2211-3748)

	Liraglutide N=4668 (%)	Placebo N=4672 (%)
System Organ Class Preferred Term	N (%)	N (%)
Gastrointestinal Disorders		
Diarrhea	89 (1.9)	31 (0.7)
Nausea	175 (3.7)	44 (0.9)
Vomiting	97 (2.1)	24 (0.5)
Investigations		
Lipase increased	47 (1.0)	21 (0.4)
Hepatobiliary disorders		
Cholecystitis acute*	50 (1.1)	32 (0.7)
Cholelithiasis	68 (1.5)	50 (1.1)

* Combination of the two PTs cholecystitis and cholecystitis acute

** Table is limited to those adverse events for which a meaningful difference in rate was observed.

Medullary thyroid cancer: see (**WARNINGS AND PRECAUTIONS, Serious Warnings and Precautions**) Calcitonin, a biological marker of MTC, was measured throughout the clinical development program. At the end of the glycemic control trials, adjusted mean serum calcitonin concentrations were higher in Victoza[®]-treated patients compared to placebo-treated patients but not compared to patients receiving active comparator. Between group differences in adjusted mean serum calcitonin values were approximately 0.1 ng/L or less. Among patients with pretreatment calcitonin <20 ng/L, calcitonin elevations to >20 ng/L occurred in 0.7% of Victoza[®]-treated patients, 0.3% of placebo-treated patients, and 0.5% of active-comparator-treated patients. The clinical significance of these findings is unknown.

Papillary thyroid cancer: In the completed trials the rates of papillary thyroid carcinoma were 1.5 and 0.5 (liraglutide vs. non-liraglutide) events per 1000 subjects-years of exposure. Papillary (follicular) thyroid cancers occurred at a higher frequency in the liraglutide clinical development programme than in the general Canadian population. Subjects included in the liraglutide clinical trial program underwent thyroid related assessments, leading to a high number of thyroidectomies. The majority of papillary carcinomas were incidental findings arising from thyroidectomies performed as a result of elevations in serum calcitonin; all but one of the papillary carcinomas were microcarcinomas of less than 1.0 cm. In subjects with pre-existing thyroid disease, the rates of thyroid neoplasms were comparable for liraglutide and placebo (28.8 per 1000 subject-years and 29.3 per 1000 subject-years; none in active comparator).

Thyroid disease: Thyroid adverse events, such as goitre, have been reported in clinical trials, in particular in patients with pre-existing thyroid disease. Victoza[®] should therefore be used with caution in these patients.

Neoplasms: In the intermediate and long-term trials, 115 treatment emergent neoplasm adverse events were reported and of these, 45 events were classified as malignant neoplasms. The proportion and rate (shown in brackets) of subjects with neoplasm adverse events (benign and malignant) was 1.8% (26.9 cases per 1000 subject-years), 1.2% (17.0 per cases 1000 subject-years) and 1.3% (25.3 cases per 1000 subject-years) for liraglutide, active comparator and placebo, respectively. The proportion and rate of subjects with malignant neoplasm adverse events was 0.8% (10.9 cases per 1000 subject-years), 0.5% (7.2 cases per 1000 subject-years) and 0.3% (6.3 cases per 1000 subject-years) for liraglutide, active comparator and placebo, respectively.

Thyroid neoplasms were the most common neoplasm adverse events. The proportion and rate of subjects with benign thyroid neoplasms were higher for subjects treated with liraglutide compared to subjects treated with active comparator and placebo [liraglutide: 1.1% (16.0 cases per 1000 subject-years); active comparator: 0.6% (9.8 cases per 1000 subject-years); placebo: 1.0% (19.0 cases per 1000 subject-years)]. With regard to malignant neoplasms which are of more clinical relevance, prostate cancer, breast cancer, thyroid cancer, basal cell carcinoma, rectal cancer, renal cell carcinoma and colon cancer were the most commonly reported across treatment groups. The proportion of subjects with malignant prostate cancer, breast cancer, renal cell carcinoma and colon cancer were similar for subjects treated with liraglutide and either one of the comparators. No cases of rectal cancer or basal cell carcinoma were reported with comparators. The remaining malignant neoplasms occurred at low rates with no apparent pattern in type of neoplasms.

In another clinical trial comparing Victoza® + metformin to sitagliptin + metformin (Trial NN2211-1860) over 52 weeks, considering all adverse events in the system organ class “neoplasms benign, malignant and unspecified (including cysts)”, 2 subjects (0.9%) reported 2 events, 8 subjects (3.7%) reported 9 events and 2 subjects (0.9%) reported 2 events for liraglutide 1.2 mg + metformin, liraglutide 1.8 mg + metformin and sitagliptin + metformin, respectively. Of these, there was 1 malignant neoplasm (epiglottic carcinoma) reported in the liraglutide 1.2 mg + metformin group, 3 malignant neoplasms (breast cancer, colon cancer and pancreatic carcinoma) reported in the liraglutide 1.8 mg + metformin group and 1 malignant neoplasm (renal cancer) reported in the sitagliptin + metformin group. No thyroid cancers were observed.

In the LEADER trial, neoplasms were evaluated based on events confirmed by adjudication. The incidences of EAC confirmed overall neoplasms (liraglutide: 10.1%, 3.3 events per 100 patient years of observation; placebo: 9.0%, 3.0 events per 100 patient years of observation), benign neoplasms (liraglutide: 3.6%, 1.0 events per 100 patient years of observation; placebo: 3.1%, 1.0 events per 100 patient years of observation), and malignant neoplasms (liraglutide: 6.3%, 2.0 events per 100 patient years of observation; placebo: 6.0%, 1.8 events per 100 patient years of observation) were comparable between the treatment groups.

Cardiovascular: Adverse events identified using a composite endpoint for all tachyarrhythmias in pooled intermediate and long-term trials (Phase 3a LEAD™), including open label arms, occurred at rates of 16.5, 6.1, and 15.3 per 1000 subject-years in the liraglutide, placebo and active comparator groups respectively. The respective proportions were 0.7, 0.2 and 0.7 per cent. The most commonly reported episodes of tachyarrhythmia were extrasystoles. The rate of pooled events of atrial fibrillation, atrial flutter, supraventricular tachycardia and supraventricular arrhythmia was 6.4 per 1000 subject-years in the liraglutide group and 5.6 per 1000 subject-years in the active comparator group; no events were reported in the placebo group. Rates of adverse events related to tachyarrhythmia reported as Serious Adverse Events were 2.7, 0 and 2.8 per 1000 subject-years in the Victoza®, placebo and active comparator groups respectively.

In pooled long-term trials (Phase 3a LEAD™), the rate of first-degree AV block was reported to be 2.6, 0 and 1.4 per 1000 subject-years in the liraglutide, placebo and active comparator groups.

In the above trials patients were excluded in case of known clinically significant active cardiovascular disease including history of myocardial infarction within the past 6 months and/or heart failure, at the discretion of the Investigator, and uncontrolled treated/untreated hypertension (systolic blood pressure =180 mmHg and/or diastolic blood pressure =100 mmHg).

(see also WARNINGS AND PRECAUTIONS, Special Populations, Cardiovascular – patients with recent MI, unstable angina and congestive heart failure; DRUG INTERACTIONS, Drug-Drug Interactions, Drugs that increase the Heart Rate and Drugs that cause PR interval prolongation; ACTION AND CLINICAL PHARMACOLOGY, Cardiac Electrophysiology)

In trial 1860, by 26 weeks, the overall adverse event of cardiac disorders occurred at rates of 2.7%, 0.9% and 0.9% in patients receiving liraglutide 1.2 mg + metformin, liraglutide 1.8 mg + metformin and sitagliptin + metformin respectively. By 52 weeks, the overall adverse event of cardiac disorders occurred at rates of 4.1%, 1.8% and 1.4% in patients receiving liraglutide 1.2 mg + metformin, liraglutide 1.8 mg + metformin and sitagliptin + metformin group.

Increase in Heart Rate: In patients with diabetes, a mean increase in heart rate from baseline of 2 to 3 beats per minute was observed with Victoza® in long-term clinical trials including LEADER. In the LEADER trial, no long-term adverse clinical impact of increased heart rate on the risk of cardiovascular events was observed and the proportion of patients with adverse events related to arrhythmias, was similar between Victoza® and placebo.

Blood Pressure: In the LEADER trial, systolic blood pressure was reduced with Victoza® vs placebo (-1.4 mmHg vs -0.2 mmHg; ETD: -1.20 mmHg [-1.92; -0.48]), whereas diastolic blood pressure decreased less with liraglutide vs placebo (-0.8 mmHg vs -1.4 mmHg, respectively, ETD: 0.59 [0.19; 0.99]) after 36 months.

Pancreatitis: In clinical trials of Victoza® there were 13 cases of pancreatitis among Victoza®-treated patients and 1 case among comparator-treated patients (2.4 vs. 0.5 cases per 1000 subject-years). Nine cases with Victoza® were reported as acute pancreatitis and 4 cases with Victoza® were reported as chronic pancreatitis. All events were serious except for one case of chronic pancreatitis in a patient treated with Victoza®. One fatal case of pancreatitis with necrosis was observed, in a Victoza®-treated patient. (see WARNINGS AND PRECAUTIONS, Pancreatitis).

In the LEADER trial, acute pancreatitis was confirmed by adjudication in 18 Victoza®-treated patients (1.1 cases per 1000 patient years of observation) and 23 placebo-treated patients (1.7 cases per 1000 patient years of observation), both on a background of standard of care. In addition, there were no cases of chronic pancreatitis confirmed by adjudication in Victoza®-treated patients and 2 cases in placebo-treated patients. The LEADER trial enrolled 267 patients with a medical history of acute or chronic pancreatitis; of these 2 out of 147 (1.4%) in the Victoza® group and 6 out of 120 (5.0%) in the placebo group had a new event of acute pancreatitis confirmed by adjudication (see WARNINGS AND PRECAUTIONS, Pancreatitis).

Pancreatic enzymes: Victoza® is associated with mean increases from baseline in pancreatic enzymes, lipase and amylase, of up to 38% and 21%, respectively (see WARNINGS AND PRECAUTIONS, Pancreatitis). In the clinical trial program elevations of serum lipase and amylase were not predictive of pancreatitis. The clinical significance of elevated lipase and amylase values is unknown.

Hypoglycemia: Severe hypoglycemic episodes in the long-term phase 3a trials were rare (9 episodes in 8 subjects). In a phase 3b clinical trial, comparing Victoza® + metformin to sitagliptin + metformin (Trial NN2211-1860) one major episode of hypoglycemia was reported in a Victoza®-treated patient. When insulin detemir was added to Victoza® 1.8 mg and metformin, no severe hypoglycemic event (patient not able to self-treat) was observed.

Six of these severe episodes were reported when liraglutide was used in combination with glimepiride, thus when liraglutide was used in combination with a sulfonylurea or insulin, an increased rate of hypoglycemia was observed (see WARNINGS AND PRECAUTIONS, Endocrine and Metabolism, Hypoglycemia and DOSAGE AND ADMINISTRATION, Dosing Considerations).

In trial 1572 (LEAD™ 2) the rate of minor hypoglycemic episodes was 0.14, 0.03, 0.09, 0.13 and 1.23 events/subject year in the liraglutide 0.6 mg + metformin, liraglutide 1.2 mg + metformin, liraglutide 1.8 mg + metformin, placebo + metformin, and glimepiride + metformin groups respectively; the corresponding proportion of affected subjects was 3.3%, 0.8%, 2.5%, 2.5% and 16.9%, respectively. Rates of minor nocturnal hypoglycemia were 0.00, 0.02, 0.00, 0.02 and 0.05 events/subject year, respectively.

In trial 1697 (LEAD™ 5) the rate of minor hypoglycemic episodes was 1.16, 0.95 and 1.29 events/subject year in the liraglutide 1.8 mg + metformin + glimepiride, placebo + metformin + glimepiride and insulin glargine + glimepiride + metformin groups respectively; the corresponding proportion of affected subjects was 27.4%, 16.7% and 28.9% respectively. Severe hypoglycemic episodes were only reported in the liraglutide group where 6 events were reported in 5 subjects. Rates of severe hypoglycemia were 0.06, 0.00, 0.00 events/subject year and rates of nocturnal hypoglycemia were 0.16, 0.19, 0.23 events/subject year, in the liraglutide 1.8 mg + metformin + glimepiride, placebo + metformin + glimepiride and insulin glargine + glimepiride + metformin groups respectively.

In trial 1860 the rate of minor hypoglycemia episodes was 0.18, 0.37 and 0.11 events/subject year in the liraglutide 1.2 mg + metformin, liraglutide 1.8 mg + metformin and sitagliptin + metformin groups respectively; the corresponding proportion of affected subjects was 5.4%, 5.0% and 4.6% respectively. The rates of all hypoglycemia episodes as well as minor episodes were significantly higher in the liraglutide 1.8 mg + metformin treatment group as compared to the sitagliptin + metformin group.

In trial 1842 when insulin was added to Victoza® 1.8 mg and metformin no severe hypoglycemic event was observed. The rate of minor hypoglycemic episodes (patient able to self-treat) during the 26-week main trial and 26-week extension period was low across all treatment groups, at 0.23, 0.03 and 0.12 events per subject years for insulin detemir + liraglutide 1.8 mg + metformin, liraglutide 1.8 mg + metformin and non-randomized liraglutide 1.8 mg + metformin, respectively. The incidence of minor hypoglycemic episodes was statistically significantly higher in the detemir + liraglutide 1.8 mg + metformin treatment group than in the liraglutide 1.8 mg + metformin group ($p=0.0011$), when excluding an outlier in the liraglutide 1.8 mg + metformin group with a medical history of frequent hypoglycemia.

In the LEADER trial, severe and confirmed hypoglycemia episodes were primarily seen in subjects treated with insulin, sulfonylurea (SU)/glinides or a combination of these at baseline (i.e., 90% of subjects with severe hypoglycemia in either treatment group were on insulin and/or SU/glinides at baseline). Severe episodes of hypoglycemia are characterized in **Table 6** below. The majority of hypoglycemia events were considered “symptomatic episodes”.

Table 6 Characteristics of severe hypoglycemic episodes – summary – full analysis set

	Liraglutide			Placebo		
	N (%)	E	R	N	E	R
Number of Subjects	4668			4672		
PYO	17341			17282		
Severe hypoglycemia episodes	114 (2.44)	178	1.03	153 (3.27)	255	1.48
Episodes with seizure or coma	21 (0.4)	26	0.15	18 (0.4)	18	0.10
Symptomatic episodes	111 (2.4)	170	0.98	145 (3.1)	240	1.39
Episodes related to exercise	9 (0.2)	9	0.05	11 (0.2)	13	0.08
Registered as an SAE	55 (1.2)	70	0.40	88 (1.9)	111	0.64

N: Number of subjects, %: Proportion of subjects, PYO: Patient years of observation, E: Number of events, R: Event rate per 100 patient years of observation, Severe: an episode requiring assistance of another person to actively administer carbohydrate, glucagon, or other resuscitative actions, SAE: Serious adverse event, SU: Sulfonylureas Serious adverse event as listed by the investigator in relation to the hypoglycemic episode.

Gastrointestinal adverse events: In pooled long term clinical trials, gastrointestinal adverse events were reported in 41% of Victoza[®] treated patients and were dose related. Gastrointestinal adverse events occurred in 17% of comparator-treated patients. Events that occurred more commonly among Victoza[®] treated patients included nausea, vomiting, diarrhea, dyspepsia and constipation. Approximately 13% of Victoza[®] treated patients and 2% of comparator-treated patients reported nausea during the first 2 weeks of treatment. Most episodes of nausea were mild or moderate in severity and declined over time (see **Figure 1**). Withdrawals due to gastrointestinal adverse events occurred in 5.0% of Victoza[®] treated patients and 0.5% of comparator-treated patients, mainly during the first 2–3 months of the trials.

In trial NN2211-1860, 16.3%, 17.4%, 2.7% of patients reported nausea during the first 2 weeks of treatment in the liraglutide 1.2 mg + metformin, liraglutide 1.8 mg + metformin and sitagliptin + metformin groups respectively.

In trial NN2211-1842, 14.1%, 18.9% and 24.2% of patients reported nausea during the first 12 weeks of treatment in the insulin detemir + liraglutide 1.8 mg + metformin, liraglutide 1.8 mg + metformin and the non-randomized liraglutide 1.8 mg + metformin groups, respectively. During the subsequent 52 weeks of treatment, 2.5%, 1.9% and 3.6% of patients reported nausea in the insulin detemir + liraglutide 1.8 mg + metformin, liraglutide 1.8 mg + metformin and non-randomized liraglutide 1.8 mg + metformin groups, respectively. In total, 8.6% (N=85) of patients withdrew from the trial due to gastrointestinal adverse events.

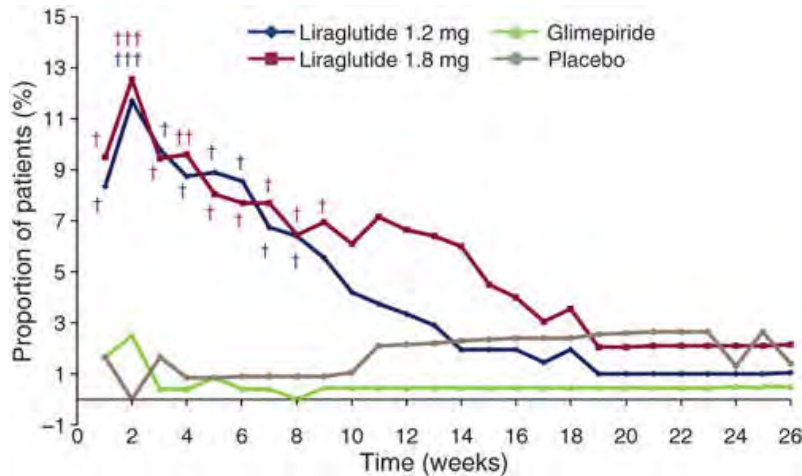

Figure 1 Observed proportion of patients experiencing nausea by treatment over time in LEAD™-2 †††p<0.0001, ††p<0.01, † p<0.5 vs. placebo.

The rate of gastrointestinal disorders in Victoza® treated subjects increased with age, especially at the 1.8 mg dose of Victoza® (see also INDICATIONS, Geriatrics (>65 years of age). WARNINGS AND PRECAUTIONS, Special Populations, Gastrointestinal disease; DOSAGE AND ADMINISTRATION, Dosing considerations; ACTION AND CLINICAL PHARMACOLOGY, Pharmacodynamics, Gastric emptying)

Patients with mild, moderate and severe renal insufficiency (creatinine clearance 60-90 mL/min, 30–59 mL/min and < 30 mL/min respectively) may experience more gastrointestinal effects when treated with liraglutide.

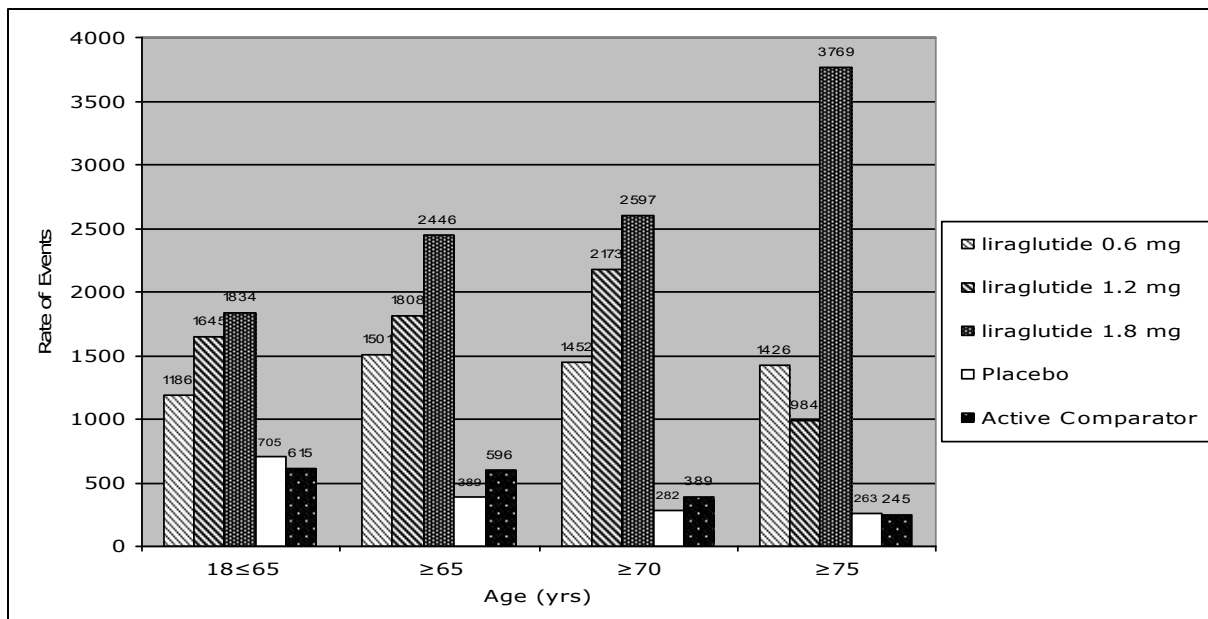

Figure 2 Rate of Events with Gastrointestinal Disorders by Treatment and Age Group - All Long-term Trials - Safety Analysis Set

Cholelithiasis and cholecystitis: In glycemic control trials of Victoza[®], the incidence of cholelithiasis was 0.3% in both Victoza[®]-treated and placebo-treated patients. The incidence of cholecystitis was 0.2% in both Victoza[®]-treated and placebo-treated patients.

In the LEADER trial, the incidence of cholelithiasis was 1.5% (3.9 cases per 1000 patient years of observation) in Victoza[®]-treated and 1.1% (2.8 cases per 1000 patient years of observation) in placebo-treated patients, both on a background of standard of care. The incidence of acute cholecystitis was 1.1% (2.9 cases per 1000 patient years of observation) in Victoza[®]-treated and 0.7% (1.9 cases per 1000 patient years of observation) in placebo-treated patients.

Immunogenicity: Consistent with the potentially immunogenic properties and peptide pharmaceuticals, patients treated with Victoza[®] may develop anti-liraglutide antibodies. The detection of antibody formation is highly dependent on the sensitivity and specificity of the assay. Additionally, the observed incidence of antibody (including neutralizing antibody) positivity in an assay may be influenced by several factors including assay methodology, sample handling, timing of sample collection, concomitant medications, and underlying disease. For these reasons, the incidence of antibodies to liraglutide cannot be directly compared with the incidence of antibodies of other products.

Approximately 50 – 70% of Victoza[®]-treated patients in five double-blind clinical trials of 26 weeks duration or longer were tested for the presence of anti-liraglutide antibodies at the end of treatment. Low titers (concentrations not requiring dilution of serum) of anti-liraglutide antibodies were detected in 8.6% of these Victoza[®]-treated patients. Cross-reacting anti-liraglutide antibodies to native glucagon-like peptide-1 (GLP-1) occurred in 6.9% of the Victoza[®]-treated patients in the double-blind 52-week monotherapy trial and in 4.8% of the Victoza[®]-treated patients in the double-blind 26-week add-on combination therapy trials. These cross-reacting antibodies were not tested for neutralizing effect against native GLP-1, and thus the potential for clinically significant neutralization of native GLP-1 was not assessed. Antibodies that had a neutralizing effect on liraglutide in an in vitro assay occurred in 2.3% of the Victoza[®]-treated patients in the double-blind 52-week monotherapy trial and in 1.0% of the Victoza[®]-treated patients in the double-blind 26-week add-on combination therapy trials.

Antibody formation was not associated with reduced efficacy of Victoza[®] when comparing mean HbA_{1c} of all antibody-positive and all antibody-negative patients. However, the 3 patients with the highest titers of anti-liraglutide antibodies had no reduction in HbA_{1c} with Victoza[®] treatment.

In five double-blind glycemic control trials of Victoza[®], events from a composite of adverse events potentially related to immunogenicity (e.g. urticaria, angioedema) occurred among 0.8% of Victoza[®]-treated patients and among 0.4% of comparator-treated patients. Urticaria accounted for approximately one-half of the events in this composite for Victoza[®]-treated patients. Patients who developed anti-liraglutide antibodies were not more likely to develop events from the immunogenicity events composite than were patients who did not develop anti-liraglutide antibodies.

In the LEADER trial, anti-liraglutide antibodies were detected in 11 out of the 1247 (0.9%) Victoza[®]-treated patients with antibody measurement.

In a clinical trial with Victoza[®]-treated pediatric patients aged 10-17 years (See CLINICAL TRIALS, ELLIPSE[™]), anti-liraglutide antibodies were detected in 1 (1.5%) subject at week 26 and 5 (8.5%) subjects at week 53. None of the 5 subjects had antibodies cross-reactive to

native GLP-1 or had neutralizing antibodies.

Injection site reactions: Overall injection site reactions have been reported in approximately 2% of subjects receiving Victoza® in long-term controlled trials, most frequently bruising and pain. The rate of injection site disorders was 18.1, 27.6 and 37.6 events per 1000 subject-years of exposure for patients treated with liraglutide 0.6, 1.2 and 1.8mg as compared to 34.0 and 14.9 events per 1000 subject-years of exposure for patients treated with placebo and active comparator.

In a clinical trial comparing Victoza® + metformin to sitagliptin + metformin (Trial NN2211-1860), overall injection site reactions were reported in 3% of patients receiving Victoza®, most frequently injection site hematoma, bruising and pain. The rate of injection site disorders was 10 events reported in 8 patients out of 221 patients with liraglutide 1.2 mg and 13 events in 7 patients out of 218 patients with liraglutide 1.8 mg. There were no injection site reactions in the comparator group, as expected with oral administration only.

Less than 0.2% of Victoza®-treated patients discontinued due to injection site reactions. None of these patients were tested positive for liraglutide antibodies.

9.3 Less Common Clinical Trial Adverse Reactions

Cardiac Disorders: Angina Pectoris, Acute Myocardial Infarction, Myocardial Infarction
Coronary Artery Disease, Atrial Fibrillation, Cardiac Failure Congestive, Supraventricular
Tachycardia

Eye Disorders: Cataract

Gastrointestinal Disorders: Appendicitis Perforated, Gastritis, Inguinal Hernia, Pancreatitis

Immune System Disorders: Anaphylactic reactions

Infections and Infestations: Upper Respiratory Tract Infection, Bronchitis, Gastroenteritis,
Osteomyelitis

Neoplasms Benign, Malignant and Unspecified (Incl Cysts and Polyps): Papillary Thyroid
Cancer, Prostate Cancer, Breast Cancer

Musculoskeletal and Connective Tissue Disorders: Intervertebral Disc Protrusion,

Nervous System Disorders: Cerebrovascular Accident, Syncope

Metabolism and Nutrition Disorders: Dehydration, Hypoglycemia

Renal and Urinary Disorders: Renal impairment, Acute Renal failure

Skin and Subcutaneous Tissue Disorder: Pruritus

Respiratory, Thoracic and Mediastinal Disorders: Pulmonary Embolism

9.4 Clinical Trial Adverse Reactions (Pediatrics)

In adolescents and children aged 10 years and above the frequency, type and severity of adverse reactions, other than minor hypoglycaemic episodes, were comparable to that observed in the adult population.

Rate of minor hypoglycemic episodes was higher with liraglutide compared to placebo. No severe hypoglycemic episodes occurred in the liraglutide treatment group.

Trial	Treatment Arm	Minor Hypoglycemic Episodes	
		%	Rate
Trial 3659 A 26-week, double-blind, randomized, parallel group, placebo controlled multi-center trial followed by a 26-week open-label extension in pediatric patients with type 2 diabetes aged 10 years and above.	Liraglutide + Metformin + Insulin	40.0	1.24
	Placebo + Metformin + Insulin	13.3	0.52
	Liraglutide + Metformin	14.8	0.17
	Placebo + Metformin	5.1	0.09
Trial 1842 Multicentre, 26-week, randomized, open-label, parallel-group, multinational trial with a 26-week extension in adult patients with type 2 diabetes	Insulin detemir + Liraglutide 1.8 mg + metformin	-	0.23
	Liraglutide 1.8 mg + metformin	-	0.03
	Non-randomized Liraglutide 1.8 mg + Metformin (for 26-week extension)	-	0.12

Table 7 Minor hypoglycemic episodes in pediatric subjects in trial 3659 and adult subjects in trial 1842 during the 52-week treatment period

9.5 Post-Market Adverse Reactions

The following additional adverse reactions have been reported during post-approval use of Victoza®. Because these events are reported voluntarily from a population of uncertain size, it is generally not possible to reliably estimate their frequency or establish a causal relationship to drug exposure.

- Dehydration resulting from nausea, vomiting and diarrhea. (see PART I AND PART III: WARNINGS AND PRECAUTIONS)
- Increased serum creatinine, acute renal failure or worsening of chronic renal failure, sometimes requiring hemodialysis. (see PART I AND PART III: WARNINGS AND PRECAUTIONS)
- Angioedema and anaphylactic reactions. (see PART I: CONTRAINDICATIONS and WARNINGS AND PRECAUTIONS and PART III: SERIOUS SIDE EFFECTS AND WHAT TO DO ABOUT THEM)
- Allergic reactions: rash and pruritus
- Acute pancreatitis, hemorrhagic and necrotizing pancreatitis sometimes resulting in death (see PART I: WARNINGS AND PRECAUTIONS)
- Medullary thyroid carcinoma (see WARNINGS AND PRECAUTIONS)
- Hepatobiliary disorders: elevation of liver enzymes, hyperbilirubinemia, cholestasis, hepatitis (see ADVERSE REACTIONS)

10 DRUG INTERACTIONS

10.1 Overview

No clinically significant drug interaction has been demonstrated with Victoza®.

10.2 Drug-Drug Interactions

In vitro assessment of drug-drug interaction

Victoza® has shown very low potential to be involved in pharmacokinetic drug-drug interactions related to cytochrome P450 (CYP) and plasma protein binding.

In vivo assessment of drug-drug interaction

Drug-drug interaction has been investigated using acetaminophen, digoxin, lisinopril, griseofulvin and atorvastatin representing various degrees of solubility and permeability properties. In addition, the effect of liraglutide on the absorption of ethinylestradiol and levonorgestrel administered in an oral combination contraceptive drug has been investigated.

The delay of gastric emptying caused by liraglutide did not affect the absorption of orally administered medicinal products to any clinically relevant degree. Few patients treated with liraglutide reported at least 1 episode of severe diarrhea. Diarrhea may affect the absorption of concomitant oral medicinal products. Caution should be exercised when oral medications are concomitantly administered with Victoza®.

No drug-drug interaction studies have been performed in pediatric patients.

Acetaminophen

Victoza® did not change the overall exposure (AUC) of acetaminophen following a single dose of 1000 mg. Acetaminophen C_{max} was decreased by 31% and median time to maximum concentration (t_{max}) was delayed up to 15 min.

Atorvastatin

Victoza® did not change the overall exposure (AUC) of atorvastatin following single dose administration of atorvastatin 40 mg. Atorvastatin C_{max} was decreased by 38% and median t_{max} was delayed from 1-3 h with liraglutide.

Griseofulvin

Victoza® did not change the overall exposure (AUC) of griseofulvin following administration of a single dose of griseofulvin 500 mg. Griseofulvin C_{max} increased by 37% while median t_{max} did not change.

Digoxin

A single dose administration digoxin 1mg with liraglutide showed a reduction of digoxin AUC by 16%; C_{max} decreased by 31%. Digoxin median t_{max} was delayed from 1-1.5 h.

Lisinopril

A single dose administration of lisinopril 20 mg with liraglutide resulted in a reduction of lisinopril AUC by 15%; C_{max} decreased by 27%. Lisinopril median t_{max} was delayed from 6-8 h with liraglutide.

Oral contraceptives

Victoza[®] lowered ethinylestradiol and levonorgestrel C_{max} by 12% and 13%, respectively, following administration of a single dose of an oral contraceptive product. t_{max} was 1.5 h later with liraglutide for both compounds. There was no clinically relevant effect on the overall exposure (AUC) of either ethinylestradiol or levonorgestrel. The contraceptive effect is therefore anticipated to be unaffected when co-administered with liraglutide.

Warfarin and other coumarin derivatives

No interaction study has been performed. A clinically relevant interaction with active substances with poor solubility, or with narrow therapeutic index such as warfarin cannot be excluded. Upon initiation of liraglutide treatment in patients on warfarin or other coumarin derivatives more frequent monitoring of INR (International Normalized Ratio) is recommended.

Combination with Insulin

No pharmacokinetic interaction was observed between Victoza[®] and insulin detemir when separate subcutaneous injections of insulin detemir 0.5 Units/kg (single-dose) and Victoza[®] 1.8 mg (steady state) were administered in patients with type 2 diabetes.

Drugs that Increase Heart Rate

Victoza[®] causes an increase in heart rate (see ACTION AND CLINICAL PHARMACOLOGY, Cardiac Electrophysiology). The impact on the heart rate of co-administration of Victoza[®] with other drugs that increase heart rate, (e.g., sympathomimetic drugs) has not been evaluated in drug-drug interaction studies. As a result, co-administration of Victoza[®] with these drugs should be undertaken with caution.

Drugs that Cause PR Interval Prolongation

Victoza[®] causes an increase in the PR interval (see ACTION AND CLINICAL PHARMACOLOGY, Cardiac Electrophysiology). The impact on the PR interval of co-administration of Victoza[®] with other drugs that prolong the PR interval (including calcium channel blockers, beta-adrenergic blockers, digitalis glycosides, and HIV protease inhibitors) has not been evaluated in drug-drug interaction studies. As a result, co-administration of Victoza[®] with these drugs should be undertaken with caution.

10.3 Drug-Food Interactions

There are no known interactions with food.

10.4 Drug-Herb Interactions

Interactions with herbal products have not been established.

11 ACTION AND CLINICAL PHARMACOLOGY

11.1 Mechanism of Action

Liraglutide is a human Glucagon-Like Peptide-1 (GLP-1) analogue with 97% homology to human GLP-1 that binds to and activates the GLP-1 receptor. The GLP-1 receptor is the target for native GLP-1, an endogenous incretin hormone that potentiates glucose-dependent insulin secretion from the pancreatic beta cells. Unlike native GLP-1, liraglutide has a pharmacokinetic profile in humans suitable for once daily administration. Following subcutaneous administration, the protracted action profile is based on three mechanisms: self-association, which results in

slow absorption, binding to albumin and enzymatic stability towards the dipeptidyl peptidase (DPP-IV) and neutral endopeptidase (NEP) enzymes resulting in a long plasma half-life.

Liraglutide action is mediated via a specific interaction with GLP-1 receptors, leading to an increase in cyclic adenosine monophosphate (cAMP). Liraglutide stimulates insulin secretion in a glucose-dependent manner. Simultaneously, liraglutide lowers glucagon secretion, also in a glucose-dependent manner. Thus, when blood glucose is high, insulin secretion is stimulated and glucagon secretion is inhibited. Conversely, when blood glucose is low, liraglutide diminishes insulin secretion and does not impair glucagon secretion. The mechanism of blood glucose lowering also involves a delay in gastric emptying.

11.2 Pharmacodynamics

Victoza[®] has 24-hour duration of action and improves long-term glycemic control by lowering fasting and postprandial blood glucose in patients with type 2 diabetes mellitus. Inadequately controlled hyperglycemia is associated with an increased risk of diabetic complications, including cardiovascular disorders, diabetic nephropathy, retinopathy and neuropathy.

Victoza[®] 1.8 mg and 1.2 mg reduced the mean fasting glucose by 3.90 mmol/L and 3.33 mmol/L, respectively, when compared to placebo (**Figure 3**). Following a standard meal, the difference versus placebo in mean 2-hour postprandial glucose concentration was 6.02 mmol/L and 5.63 mmol/L. In addition, Victoza[®] 1.8 mg and 1.2 mg decreased the incremental postprandial glucose (defined as the difference between blood glucose values 90 minutes post and immediately before the meal across all three meals) on average by 1.1 mmol/L and 1.08 mmol/L, respectively.

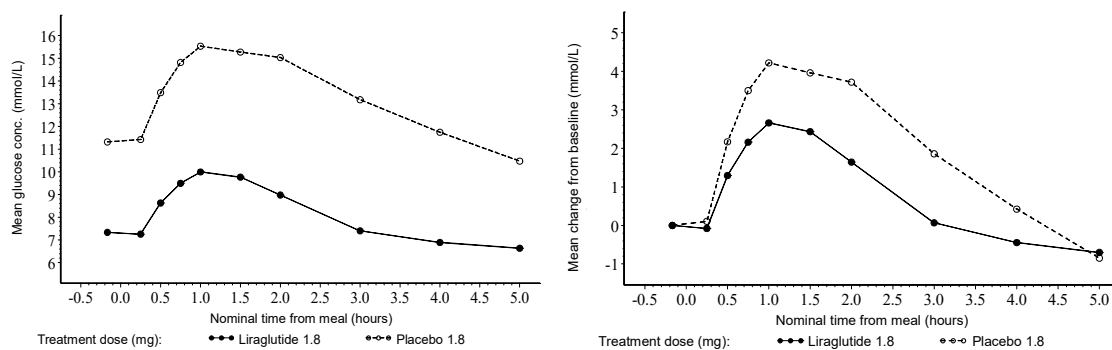

Figure 3 Mean absolute (left) and incremental (right) postprandial plasma glucose concentrations in patients with type 2 diabetes treated with liraglutide 1.8 mg or placebo in a cross-over design (N=18) (Trial 1698)

Glucose dependent insulin secretion: Victoza[®] increased insulin secretion in relation to increasing glucose concentrations. Using a stepwise graded glucose infusion, the insulin secretion rate was increased following a single dose of liraglutide in patients with type 2 diabetes to a level comparable to that observed in healthy subjects (**Figure 4**).

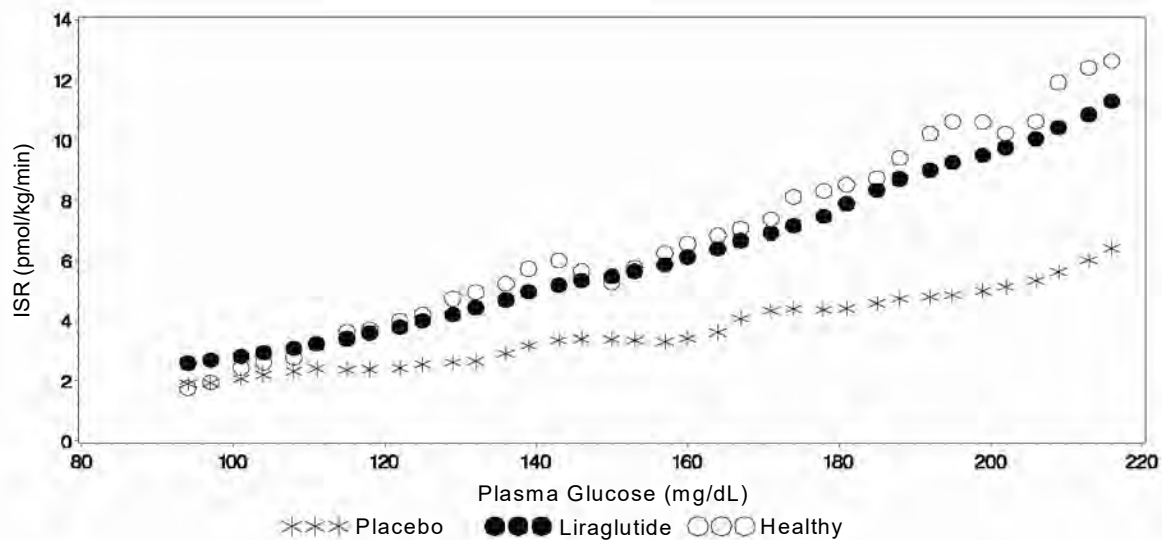

Figure 4 Mean Insulin Secretion Rate (ISR) versus glucose concentration following single dose 7.5 µg/kg (~0.66 mg) or placebo in subjects with type 2 diabetes (N=10) and untreated healthy subjects (N=10) during graded glucose infusion (Trial 2063)

Glucagon secretion: Victoza® lowered blood glucose by stimulating insulin secretion and lowering glucagon secretion. A single dose of Victoza® of ~0.7 mg did not impair glucagon response to low glucose concentrations. Furthermore, due to increased insulin and lower glucagon secretion, a lower endogenous glucose release was observed with Victoza®.

Gastric emptying: Victoza® caused a delay of gastric emptying, thereby reducing the rate at which postprandial glucose appeared in the circulation.

Cardiac Electrophysiology: A randomized, double-blind, 2-period crossover, placebo-controlled trial was performed in 51 healthy volunteers (25 M/26 F, 18-44 years). Following randomization, subjects in the liraglutide treatment arm received 0.6 mg s.c. liraglutide daily for the first week of treatment, 1.2 mg s.c. daily for the second week of treatment, and 1.8 mg s.c. daily for the third week of treatment according to an upward titration design. At the end of the second and third weeks, immediately following the seventh and final doses of 1.2 and 1.8 mg liraglutide, respectively, subjects had 24 hours of serial ECG monitoring. Subjects randomized to the placebo arm had an identical schedule of treatment and assessments with a placebo s.c. injection.

Heart Rate: Liraglutide was associated with statistically significant increases in heart rate at all time points during treatment with the 1.2 mg dose on day 14 and the 1.8 mg dose on day 21. The incidence of subjects with heart rate values greater than 90 bpm was 20.0% for liraglutide 1.2 mg versus 8.0% for placebo and 23.5% for liraglutide 1.8 mg versus 3.9% for placebo.

Time-matched Difference between Baseline Subtracted (Delta) Liraglutide and Placebo HR (bpm)

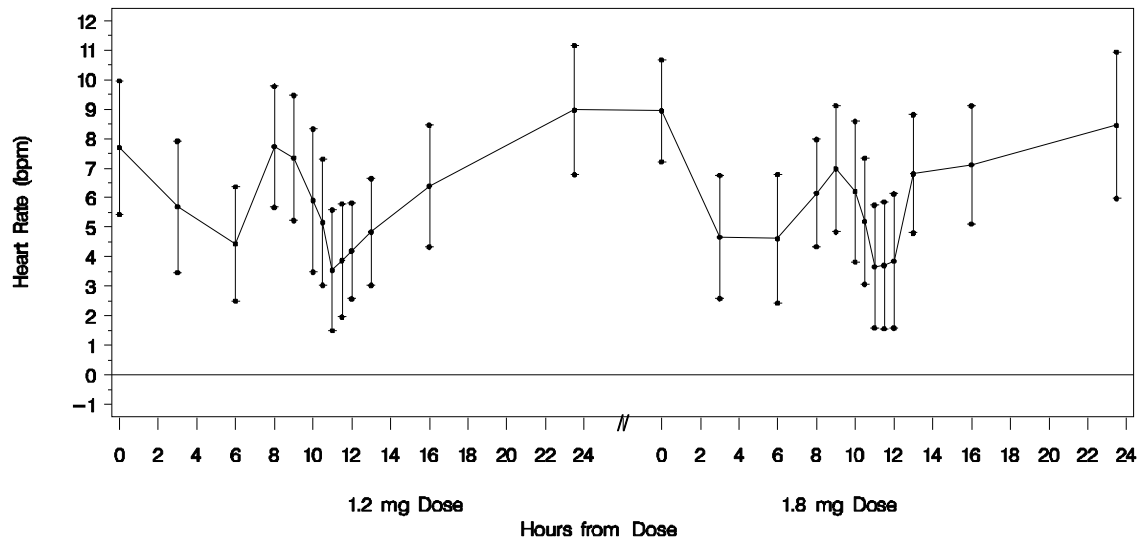

Delta: The difference between HR at current time and HR at baseline for each patient
 LCL: Lower Confidence Limit UCL: Upper Confidence Limit

Figure 5

PR Interval: Liraglutide at a dose of 1.2 mg caused statistically significant increases in the PR interval at all time points on day 14. The 1.8 mg dose of liraglutide resulted in statistically significant PR interval prolongation at 10 of 12 post-dose time points on day 21. The maximum placebo- and baseline-adjusted mean PR interval prolongation was 10.0 ms (90% CI: 6.9, 13.1) for the 1.2 mg dose and 9.0 ms (90% CI: 6.1, 12.0) for the 1.8 mg dose. Treatment-emergent PR values >200 ms were reported for 4% of subjects in the liraglutide arm and 2% of subjects in the placebo arm. The incidence of subjects who had PR values >200 ms at baseline that increased in magnitude and/or frequency during treatment was 6% for the liraglutide arm and 2% for the placebo arm.

Time-matched Difference between Baseline Subtracted (Delta) Liraglutide and Placebo PR (msec)

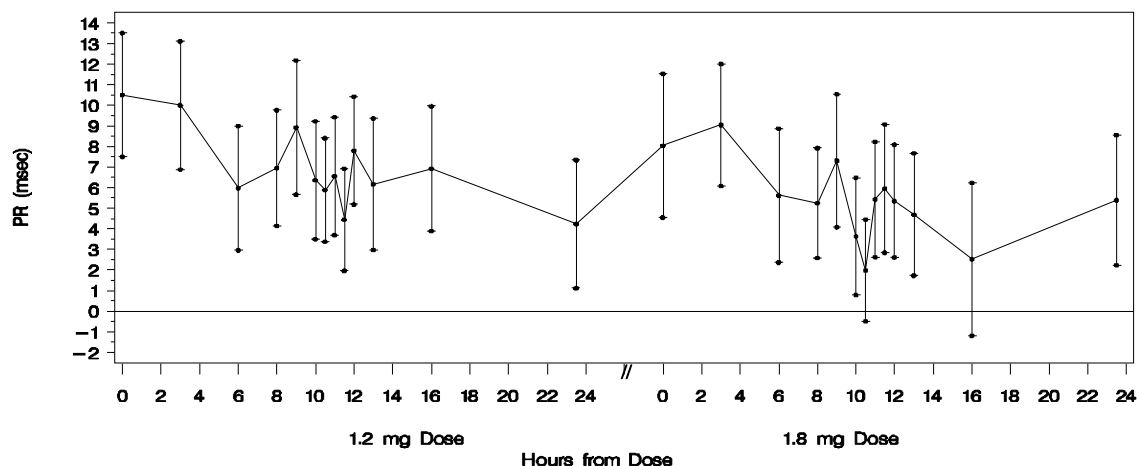

Delta: The difference between PR at current time and PR at baseline for each patient
 LCL: Lower Confidence Limit UCL: Upper Confidence Limit

Figure 6

QT Interval: Liraglutide at 1.2 mg and 1.8 mg doses was associated with statistically significant shortening of the QTc interval at most post-dose time points. The clinical significance of an acquired, drug-induced QTc shortening of this magnitude is not known.

Time-matched Difference between Baseline Subtracted (Delta) Liraglutide and Placebo QTcI (msec)

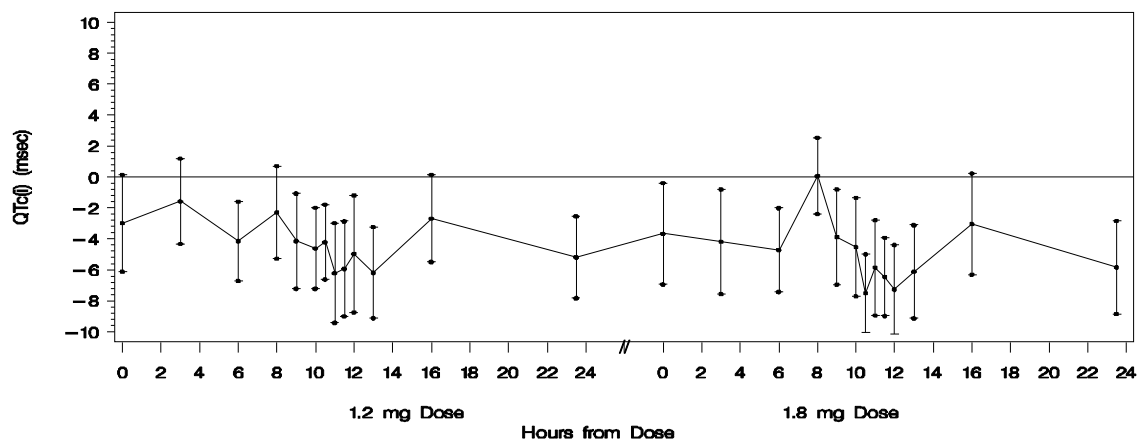

Delta: The difference between QTcI at current time and QTcI at baseline for each patient
 LCL: Lower Confidence Limit UCL: Upper Confidence Limit

Figure 7

Combination with Insulin

No pharmacodynamic interactions were observed between Victoza® and insulin detemir when administering a single dose of insulin detemir 0.5 U/kg with Victoza® 1.8 mg at steady state in patients with type 2 diabetes.

Non-Clinical Pharmacodynamics

Pharmacodynamic studies showed that liraglutide is a potent, selective and full agonist on the cloned human GLP-1 receptor and on the cloned monkey, pig, rabbit, rat and mouse receptors. The main molecular mechanisms of the protracted action profile of liraglutide is self-association, which results in slow absorption, binding to albumin, and higher enzymatic stability against the dipeptidyl peptidase IV (DPP-IV) and neutral endopeptidase (NEP) enzymes. The apparent reduced potency in the presence of albumin indicates that only the free fraction of liraglutide is responsible for its pharmacological effect in vitro as well as in vivo.

The hypoglycemic effect of liraglutide was investigated in mice, rats and pigs, and was shown to be due to glucose-dependent insulin secretion; glucose-dependent lowering of glucagon; slowing of gastric emptying; and increased beta-cell mass (only during the diabetic stage).

11.3 Pharmacokinetics

Absorption: The absorption of Victoza[®] following subcutaneous administration is slow, reaching maximum concentration 8-12 hours post dosing. Estimated maximum liraglutide concentration was 9.4 nmol/L for a subcutaneous single dose of liraglutide 0.6 mg. At 1.8 mg liraglutide, the average steady state concentration of liraglutide (AUC_{τ/24}) reached approximately 34 nmol/L. Victoza[®] exposure (AUC) increased approximately linearly with the dose (μg/kg) with increasing slope due to accumulation between days 1 and 11. The inter-subject coefficient of variation for liraglutide AUC was 11% following single dose administration. Victoza[®] can be administered subcutaneously in the abdomen, thigh, or upper arm.

The absolute bioavailability of Victoza[®] following subcutaneous administration is approximately 55%.

Distribution: The apparent volume of distribution after subcutaneous administration is 11-17 L. The mean volume of distribution after intravenous administration of Victoza[®] is 0.07 L/kg. Victoza[®] is extensively bound to plasma protein (>98%).

Metabolism: During a 24 h period following administration of a single [³H]-liraglutide dose to healthy subjects, the major component in plasma was intact liraglutide. Two minor plasma metabolites were detected (≤ 9 % and ≤ 5% of total plasma radioactivity exposure). Victoza[®] is endogenously metabolized in a similar manner to large proteins without a specific organ as major route of elimination.

Elimination: Following a [¹H]-liraglutide dose, intact liraglutide was not detected in urine or feces. Only a minor part of the administered radioactivity was excreted as liraglutide-related metabolites in urine or feces (6% and 5%, respectively). The urine and feces radioactivity were mainly excreted during the first 6-8 days, and corresponded to three minor metabolites, respectively.

The mean clearance following s.c. administration of a single dose of Victoza[®] is approximately 1.2 L/h with an elimination half-life of approximately 13 hours.

Special Populations and Conditions

Pediatrics: Pharmacokinetic properties were assessed in clinical studies in the pediatric population with type 2 diabetes aged 10-17. Based on the population pharmacokinetic analysis,

the liraglutide exposure in pediatric subjects was comparable to that in adults.

Geriatrics: Exposure (AUC) to Victoza[®] is independent of age (see DOSAGE AND ADMINISTRATION and ACTION AND CLINICAL PHARMACOLOGY).

Sex: After adjusting for body weight, AUC(0-t), C_{max}, t_{max}, AUC (0-∞), CL/F, Vz/F, and t_{1/2} appeared to be comparable between male and female subjects after administration of a single dose of liraglutide. A pharmacokinetic study in healthy subjects indicated that gender has no clinically meaningful effect on the pharmacokinetics of Victoza[®].

Ethnic origin: There seems to be no clinically relevant effect on the pharmacokinetics of Victoza[®] based on the results of a population pharmacokinetic analysis which included subjects of White, Black, Asian and Hispanic groups.

Hepatic Insufficiency: Subjects with varying degrees of hepatic insufficiency displayed a reduced exposure to Victoza[®]. After a single-dose, the AUC in mild (Child Pugh score 5-6), moderate, and severe (Child Pugh score > 9) compared to healthy subjects was lower on average by 23%, 13% and 44% respectively.

Renal Insufficiency: Subjects with varying degrees of renal insufficiency displayed a reduced exposure to Victoza[®]. After a single-dose, the AUC in mild (CrCL 50-80 mL/min), moderate (CrCL 30-50 mL/min), severe (CrCL < 30 mL/min) and end-stage renal disease requiring dialysis compared to healthy subjects was lower on average by 33%, 14%, 27% and 26%, respectively.

Obesity: Body weight significantly affects the pharmacokinetics of Victoza[®] based on results of ANCOVA analyses. The exposure of Victoza[®] decreases with an increase in baseline body weight. However, the 1.2 mg and 1.8 mg daily doses of Victoza[®] provided adequate systemic exposures over the body weight range of 40-160 kg evaluated in the clinical trials. Victoza[®] was not studied in patients with body weight >160 kg.

12 STORAGE, STABILITY AND DISPOSAL

Victoza[®] should be stored in a refrigerator (2-8°C). Do not store in the freezer or directly adjacent to the refrigerator cooling element. Do not freeze Victoza[®] and do not use Victoza[®] if it has been frozen.

After initial use of the Victoza[®] pen, the product can be stored for 30 days at room temperature (not above 30°C) or in a refrigerator (2-8°C).

13 SPECIAL HANDLING INSTRUCTIONS

Victoza[®] should be kept with the pen cap on when the pen is not in use in order to protect from light. Victoza[®] should be protected from excessive heat and sunlight. Always remove the injection needle after each injection and store the Victoza[®] pen without an injection needle attached. This prevents contamination, infection, and leakage. It also ensures that the dosing is accurate.

Each Victoza[®] pen is for use by a single patient. The Victoza[®] pen should never be shared

between patients, even if the needle is changed.

PART II: SCIENTIFIC INFORMATION

14 PHARMACEUTICAL INFORMATION

Drug Substance

Proper name: Victoza®

Chemical name: Liraglutide

Molecular formula and molecular mass: $C_{172}H_{265}N_{43}O_{51}$
3751.20 dalton

Structural formula:



Physicochemical properties: 1 mL contains 6 mg of liraglutide (produced by recombinant DNA technology in *Saccharomyces cerevisiae*). Each pre-filled pen contains 3 mL equivalent to 18 mg salt-free anhydrous liraglutide, a human GLP-1 analogue.

Product Characteristics

Victoza® (liraglutide injection) is a clear, colourless solution.

15 CLINICAL TRIALS

15.1 Trial Design and Study Demographics

The efficacy and safety of Victoza® in adults were evaluated in five randomized double-blind, controlled clinical trials 1572 (LEAD™ 2), 1697 (LEAD™ 5), 1860, 1842, 1573 (monotherapy LEAD™ 3), and 4315 (LIRA-ADD2SGLT2i). The long-term safety of Victoza® in subjects with high cardiovascular risk was evaluated in the large cardiovascular outcome trial (CVOT) EX2211-3748 (LEADER®).

The efficacy and safety of Victoza® in adolescents and children aged 10 years and above were evaluated in a randomized, double-blind, controlled clinical trial 3659 (Ellipse™).

Table 8 Summary of baseline demographics and study design for trials 1572, 1697, 1860, 1842, 1573, 4315, the cardiovascular outcome trial (CVOT) EX2211-3748 (LEADER), and the pediatric trial 3659

Study #	Trial design	Dosage, route of administration and duration	Study subjects (n)	Mean age (Range)	Sex	
					Male	Female
1572 (LEAD™ 2)	Multicentre, randomized, double-blind, double-dummy, placebo-controlled trial with an active control arm	Victoza® 0.6 mg once daily + metformin 1500 - 2000 mg/day or Victoza® 1.2 mg once daily + metformin 1500 - 2000 mg/day or Victoza® 1.8 mg once daily + metformin 1500 - 2000 mg/day or Placebo + metformin 1500 - 2000 mg/day or glimepiride 4 mg + metformin 1500 - 2000 mg/day Victoza® was administered subcutaneously and metformin and glimepiride were administered orally, once daily for 26 weeks	1087*	Mean (SD) 56.7 (9.5) Range 25-79	633 (58.2 %)	454 (41.8 %)
1697 (LEAD™ 5)	Multicentre, randomized, double-blind, placebo-controlled trial with an open-label treat-to-target insulin glargine control arm	Victoza® 1.8 mg once daily + metformin 2000 mg/day + glimepiride 2 - 4 mg/day or Placebo + metformin 2000 mg/day + glimepiride 2 - 4 mg/day or insulin glargine + metformin 2000 mg/day + glimepiride 2 - 4 mg/day Victoza® and glargine were administered subcutaneously and metformin and glimepiride were administered orally, once daily for 26 weeks	576*	Mean (SD) 57.6 (9.9) Range 24-80	325 (56.4 %)	251 (43.6 %)
1860	Multicentre, 26-week, randomized, open-label, active comparator, three-armed, parallel-group, with a 52-week extension.	Victoza® 1.2 mg once daily + metformin ≥1500 mg/day or Victoza® 1.8 mg once daily + metformin ≥1500 mg/day or sitagliptin + metformin ≥1500 mg/day Victoza® was administered subcutaneously and sitagliptin and metformin were administered orally, once daily for 26 weeks	665*	Mean (SD) 55.3 (9.2) Range 23-79	352 (53.9 %)	313 (37.1 %)

Study #	Trial design	Dosage, route of administration and duration	Study subjects (n)	Mean age (Range)	Sex	
					Male	Female
1842	Multicentre, 26 week randomized, open-label, parallel-group, multinational trial with a 26 week extension	Victoza® 1.8 mg once daily + metformin or Victoza® 1.8 mg + Levemir® (insulin detemir) + metformin or Non-randomized Victoza® 1.8 mg + metformin	987	Mean (SD) 57.1 (9.7) Range 18-80	550 (56.6 %)	437 (43.4 %)
1573 (LEAD™ 3)	Multicentre, double-blind, double-dummy, randomized, parallel, active-controlled clinical trial of 52 weeks treatment duration followed by a 52-week, open-label extension	Victoza® 1.2 mg or 1.8 mg once daily with a 1-2 week period of forced titration with liraglutide (or placebo) for reaching the intended daily dose. or Glimepiride (or placebo) titrated up to the 8-mg dose during a 4-week period.	745	Mean (SD) 53.0 (10.9) Range 19-79	371 (49.8 %)	374 (50.2 %)
EX2211-3748 (LEADER®)	Multicentre, international, randomized, double-blind, placebo controlled Cardiovascular Outcome Trial (CVOT)	Victoza® 1.8 mg once daily + standard of care or Placebo once daily + standard of care Victoza® and placebo were administered subcutaneously in a event and time-driven treatment period of 42 to 60 months	9340	Mean (SD) 64.3 (7.2) Range 49-91	6003 (64.3 %)	3337 (35.7 %)
4315 (LIRA-ADD 2SGLT2i)	Multicentre, international, randomized, double-blind, placebo controlled, two-arm, parallel-group trial	Victoza® 1.8 mg once daily + SGLT2i ± metformin or Placebo once daily + SGLT2i ± metformin	303	Mean (SD) 55.15 (10.02) Range 25-79	183 (60.4 %)	120 (39.6 %)

Study #	Trial design	Dosage, route of administration and duration	Study subjects (n)	Mean age (Range)	Sex	
					Male	Female
3659 (Ellipse™)	Multicentre, international, randomized, parallel-group, placebo controlled, 26 weeks double-blind followed by a 26-week open-label extension in subjects with T2D aged 10-17 years	Victoza® 1.8 mg once daily + metformin ± insulin or Placebo once daily + metformin ± insulin	134	Mean (SD) 14.57 (1.72) Range 10-16.9	51 (38.1 %)	83 (61.9 %)

SD = Standard Deviation

* Randomized and exposed patients

In LEAD™ 2, most (87%) subjects were white and 9% were categorized as Asian or Pacific Islanders. Subjects had a mean duration of diabetes of 7.4 years (range 4 months to 41 years). Before entering the trial, 36% of subjects were treated with a single oral antidiabetic agent and 64% of subjects were treated with 2 or more oral antidiabetic agents.

In LEAD™ 5, most subjects were white (75%) and 16% were categorized as Asian or Pacific Islanders. Subjects had a mean duration of diabetes of 9 years (range 5 months to 44 years). Before entering the trial, 6% of subjects were treated with a single oral antidiabetic agent and 84% of subjects were treated with two or more oral antidiabetic agents.

In 1860, subjects had a mean weight of 93.8 kg, a mean BMI of 32.8 kg/m², a mean duration of diabetes of 6.2 years and a mean baseline HbA_{1c} of 8.5 %. The majority of subjects (86.6%) were white with 7.2% of subjects being Black or African American. Approximately 16% were of Hispanic or Latino ethnicity.

15.2 Study Results

Combination Therapy with Metformin (LEAD™ 2)

In a 26-week study, 1091 patients with type 2 diabetes and at least 3 months of treatment with various oral antidiabetic agents were randomized in a 2:2:2:1:2 manner to Victoza® 1.8 mg, Victoza® 1.2 mg, Victoza® 0.6 mg, placebo or glimepiride, all as add-on to metformin. At the time of randomisation, subjects were stratified with respect to their previous OAD therapy (monotherapy or combination therapy). Randomisation took place after a 3-week forced metformin titration period, followed by a metformin maintenance period of another 3 weeks. During the titration period, the dose of metformin was increased to 2000 mg. After randomisation, a 2-week titration period commenced followed by a 24-week maintenance treatment period with fixed doses of Victoza® and glimepiride (4 mg). The glimepiride dose used in the study was less than the maximum approved dose of glimepiride in Canada (8 mg), but equal to the maximal dose approved in some of the other participating countries. During the trial, the Victoza® and glimepiride doses were fixed, while the dose of metformin was to be maintained throughout the study if possible. However, the dose level could be decreased to a

minimum of 1500 mg and increased again to 2000 mg at the discretion of the investigator. The percentage of patients who discontinued due to ineffective therapy was 5.4% in the Victoza® 1.8 mg *plus* metformin group and 3.7% in the glimepiride *plus* metformin group. Treatment with Victoza® 1.8 mg and 1.2 mg (but not 0.6 mg) in combination with metformin resulted in mean reductions in HbA_{1c} that were non-inferior to treatment with glimepiride in combination with metformin (**Table 9**).

Table 9 Results of a 26-week trial of Victoza® in combination with metformin

	Victoza® 1.8 mg + metformin	Victoza® 1.2 mg + metformin	Placebo + metformin	Glimepiride 4 mg + metformin
Intent-to-Treat Population (N)	242	240	121	242
HbA_{1c} (%) (Mean)				
Baseline	8.4	8.3	8.4	8.4
Change from baseline (adjusted mean) ^b	-1.0	-1.0	+0.1	-1.0
Difference from glimepiride + metformin arm (adjusted mean) ^b	0.0	0.0		
95% Confidence Interval	(-0.2, 0.2)	(-0.2, 0.2)		
Patients (%) achieving A _{1c} <7%	42	35	11	36
Fasting Plasma Glucose (mmol/L) (Mean)				
Baseline	10.05	9.94	10.11	10
Change from baseline (adjusted mean) ^b	-1.68	-1.63	+0.40	-1.31
Difference from glimepiride + metformin arm (adjusted mean) ^b	-0.38	-0.33		
Body Weight (kg) (Mean)				
Baseline	88.0	88.5	91.0	89.0
Change from baseline (adjusted mean) ^b	-2.8	-2.6	-1.5	+1.0
Difference from glimepiride + metformin arm (adjusted mean) ^b	-3.8**	-3.5**		
95% Confidence Interval	(-4.5, -3.0)	(-4.3, -2.8)		

^aIntent-to-treat population using last observation on study

^bLeast squares mean adjusted for baseline value* p-value <0.0001

Combination Therapy with metformin Trial 1860

In a 26-week study, 665 patients with type 2 diabetes and inadequately controlled with metformin monotherapy were randomized in a 1:1:1 manner to receive a once-daily dose of 1.2 mg liraglutide, 1.8 mg of liraglutide, or 100 mg of sitagliptin as an add-on to their stable pre-trial metformin dose (≥ 1500 mg). Twenty-six weeks after randomization, all subjects completing the trial were offered continued participation in the trial extension. Of these, 89.7% of patients entered the additional 52 weeks of treatment.

After randomization, patients assigned to Victoza® 1.2 mg or 1.8 mg underwent a titration scheme with weekly 0.6 mg increments to reach a final dose of 1.2 mg or 1.8 mg per day. Victoza® and metformin doses were fixed during the trial.

The percentage of patients who discontinued due to ineffective therapy after 52 weeks of treatment was 2.7% in the Victoza® 1.2 mg + metformin group, 1.4% in the Victoza® 1.8 mg + metformin group and 5.0% in the Sitagliptin + metformin group. Treatment with Victoza® 1.2 mg and 1.8 mg, both in combination with metformin, resulted in a statistically significant mean

reduction in HbA_{1c} compared to Sitagliptin + metformin (See **Table 10**) at Weeks 26.

Table 10 Results of a 26-week trial 1860 of Victoza[®] versus sitagliptin (both in combination with metformin)

	Victoza [®] 1.2 mg + metformin	Victoza [®] 1.8 mg + metformin	Sitagliptin + metformin
Full Analysis Set Population (N)	221	218	219
HbA_{1c} (%) (Mean)			
N	211	214	210
Baseline	8.4	8.4	8.5
Change from baseline (adjusted mean) ^b	-1.24	-1.50	-0.9
Difference from sitagliptin + metformin arm (adjusted mean) ^b	-0.34**	-0.60	
95% Confidence Interval	-0.51; -0.16	-0.77; -0.43	
Patients (%) achieving A _{1c} <7%	43.4	54.6	22.4
FPG (mmol/L) (Mean)			
N	210	212	210
Baseline	10.1	10.0	10.0
Change from baseline (adjusted mean) ^b	-1.87	-2.14	-0.83
Body Weight (kg) (Mean)			
N	215	214	215
Baseline	93.9	94.9	93.1
Change from baseline (adjusted mean) ^b	-2.86	-3.38	-0.96

^aIntent-to-treat population using last observation carried forward

^bLeast squares mean adjusted for baseline value

**p-value <0.0001

Testing for statistical superiority was performed only after Victoza[®] 1.2 mg and 1.8 mg in combination with metformin was demonstrated to be non-inferior to sitagliptin treatment in combination with metformin.

After 12 months of treatment, the reductions in HbA_{1c} observed after the first 6 months with both liraglutide doses in combination with metformin were sustained. The estimated mean changes in HbA_{1c} after 52 weeks of treatment were -1.29% and -1.51% in the liraglutide + metformin groups (1.2 and 1.8 mg) and -0.88% in the sitagliptin + metformin group. The estimated proportion of subjects who achieved the ADA target of HbA_{1c} < 7%, at Week 52, were 50.3% in the 1.2 mg liraglutide + metformin group, 63.3% in the 1.8 mg liraglutide + metformin group and 27.1% in the sitagliptin + metformin group.

Combination Therapy with Metformin and Sulfonylurea (LEAD™ 5)

In a 26-week study, 581 patients with type 2 diabetes and at least 3 months of treatment with various oral antidiabetic regimens were randomized to Victoza[®] 1.8 mg, placebo or insulin, all as add-on to metformin and glimepiride. Randomization took place after a 6-week run-in period consisting of a 3-week forced metformin and glimepiride titration period followed by a maintenance period of another 3 weeks. During the titration period, the doses of metformin and glimepiride were increased to 2000 mg and 4 mg respectively. The glimepiride dose used in the study was less than the maximum approved dose of glimepiride in Canada (8 mg) but equal to the maximal dose approved in some of the other participating countries and within the usual maintenance dose of 1-4 mg. After randomization, patients randomized to Victoza[®] 1.8 mg underwent a 2-week period of titration with Victoza[®]. During the trial, the Victoza[®] and metformin doses were fixed, while the dose of glimepiride could be reduced to 3 or 2 mg/day. Patients titrated the glargine dose twice-weekly during the first 8 weeks of treatment based on self-measured fasting plasma glucose on the day of titration. After Week 8, the frequency of insulin glargine titration was left to the discretion of the investigator, but, at a minimum, the glargine

dose was to be revised, if necessary, at Weeks 12 and 18.

Only 20% of glargine-treated patients achieved the pre-specified target fasting plasma glucose of ≤ 5.5 mmol/L; therefore, optimal titration of the insulin glargine dose was not achieved in most patients. Insulin titration used the in the AT.LANTUS study.

The percentage of patients who discontinued due to ineffective therapy was 0.9% in the Victoza® 1.8 mg *plus* glimepiride *plus* metformin group, 11.3% in the placebo *plus* glimepiride *plus* metformin group and 0.4% in the insulin glargine *plus* glimepiride *plus* metformin group. Treatment with Victoza® 1.8 mg in combination with glimepiride and metformin resulted in a statistically significant mean reduction in HbA_{1c} compared to placebo in combination with glimepiride and metformin, (See **Table 11**).

Table 11 Results of a 26-week trial of Victoza® in combination with metformin and sulfonylurea

	Victoza® 1.8 mg + Metformin + Glimepiride	Placebo + Metformin + Glimepiride	Insulin glargine + Metformin + Glimepiride
Intent-to-Treat Population (N)	230	114	232
HbA_{1c} (%) (Mean)			
Baseline	8.3	8.3	8.1
Change from baseline (adjusted mean) ^b	-1.3	-0.2	-1.1
Difference from placebo + metformin +glimepiride arm (adjusted mean) ^b	-1.1**		
95% Confidence Interval	(-1.3, -0.9)		
Patients (%) achieving A1c <7%	53	15	46
Fasting Plasma Glucose (mmol/l) (Mean)			
Baseline	9.17	9.44	9.11
Change from baseline (adjusted mean) ^b	-1.55	+0.55	-1.77
Body Weight (kg) (Mean)			
Baseline	85.8	85.4	85.2
Change from baseline (adjusted mean) ^b	-1.8	-0.4	1.6

^a Intent-to-treat population using last observation on study

^b Least squares mean adjusted for baseline value

**p-value <0.0001

Combination Therapy with Metformin and SGLT2i (4315)

Study 4315 was a confirmatory, randomized, double-blind, placebo-controlled, multicentre, multinational, two-arm, parallel-group trial investigating the efficacy and safety of adding Victoza® 1.8 mg/day to pre-trial treatment with any SGLT2 inhibitor (as monotherapy or in combination with metformin) in adults with T2DM inadequately controlled on stable treatment with SGLT2 inhibitor \pm metformin (HbA_{1c} of 7.0-9.5%). Eligible subjects were randomized in a 2:1 manner to receive a once-daily dose of either liraglutide (1.8 mg) or placebo. The randomization was stratified by metformin use at baseline (yes versus no). The trial period consisted of a 2-week screening period, a 26-week treatment period and a 1-week follow-up period.

A total of 303 subjects were randomized to receive Victoza® 1.8 mg/day (203 subjects) or placebo (100 subjects). All patients were taking SGLT2 inhibitors: 25.7% taking empagliflozin, 49.5% taking dapagliflozin, and 24.8% taking canagliflozin. Overall, 94.4% of randomized subjects were taking metformin.

Treatment with Victoza® 1.8 mg/day resulted in a statistically significant greater reduction of HbA_{1c} from baseline compared to placebo, each in combination with SGLT2 inhibitors with or without metformin (**Table 12**).

Table 12 Results of a 26-week trial of Victoza® in combination with metformin and sodium glucose cotransporter 2 inhibitor (SGLT2i)

	Victoza® 1.8 mg + SGLT2i* ± Metformin	Placebo + SGLT2i* ± Metformin
Intent-to-Treat Population (N)	203	100
HbA_{1c} (%) (Mean)		
Baseline	8.00	7.96
Change from baseline (adjusted mean) ^a	-0.98	-0.30
Treatment difference	-0.68**	
95% Confidence Interval	(-0.89, -0.48)	
Patients (%) achieving A1c <7% ^b	51.8	23.2
Body Weight (kg) (Mean)		
Baseline	91.0	91.4
Change from baseline (adjusted mean) ^a	-2.81	-1.99

^a Analysis using a pattern mixture model (PMM) of in-trial observation period data with missing observations imputed 1000 times based on patients who discontinue or initiate rescue therapy within each randomized treatment arm, respectively. For each of the 1000 imputed data sets the change in HbA_{1c} from baseline to week 26 were analysed using an ANCOVA with treatment, country and the stratification factor (metformin use at baseline: yes vs no) as categorical fixed effects and baseline HbA_{1c} as covariate.

^b The response status is derived from the continuous endpoint (HbA_{1c}) using a PMM with multiple imputation for missing observations.

*Victoza® add on to SGLT2i was investigated at all doses approved of SGLT2i.

**p-value <0.001

Combination Therapy with Metformin and Insulin

This 26-week open-label trial enrolled 987 patients with inadequate glycemic control (HbA_{1c} 7-10%) on metformin (≥1500 mg/day) alone or inadequate glycemic control (HbA_{1c} 7-8.5%) on metformin (≥1500 mg/day) and a sulfonylurea. Patients who were on metformin and a sulfonylurea discontinued the sulfonylurea at start of run-in (Week -12). All patients entered a 12-week run-in period during which they received add-on therapy with Victoza® titrated to 1.8 mg once-daily. The greatest change in HbA_{1c} and body weight was observed during the 12-week run-in period; subjects in the randomized groups had a mean screening HbA_{1c} of 8.3% which decreased to 7.6% and observed change in body weight was 3.5 kg. At the end of the run-in period, 498 patients (50%) achieved HbA_{1c} <7% with Victoza® 1.8 mg and metformin and continued treatment in a nonrandomized, observational arm. Another 167 patients (17%) withdrew from the trial during the run-in period with approximately one-half of these patients doing so because of gastrointestinal adverse reactions (see ADVERSE REACTIONS). The remaining 323 patients with HbA_{1c} ≥7% (33% of those who entered the run-in period) were randomized to 26 weeks of once-daily insulin detemir administered in the evening as add-on therapy (N=162) or to continued, unchanged treatment with Victoza® 1.8 mg and metformin (N=161). The starting dose of insulin detemir was 10 units/day and the mean dose at the end of the 26-week randomized period was 39 units/day (0.41 U/kg). During the 26-week randomized treatment period, the percentage of patients who discontinued due to ineffective therapy was 3.1% in the group randomized to continued treatment with Victoza® 1.8 mg and metformin and 1.2% in the group randomized to add on therapy with insulin detemir. The total percentage of withdrawals was 21.1% (N=34) in the group randomized to continued treatment with Victoza®

1.8 mg and metformin and 11.1% (N=18) in the group randomized to add on therapy with insulin detemir.

Treatment with insulin detemir as add-on to Victoza® 1.8 mg + metformin resulted in a statistically significant reduction in HbA_{1c} compared to continued, unchanged treatment with Victoza® 1.8 mg + metformin alone (see **Table 13**).

Table 13 Results of a 26-week open-label trial of insulin detemir as add on to Victoza® + metformin compared to continued treatment with Victoza® + metformin alone in patients not achieving HbA_{1c} < 7% after 12 weeks of metformin and Victoza® (Week -12 to 0)

	Victoza® + metformin + Insulin	Victoza® + metformin
Intent-to-Treat Population (N)	162	157
HbA_{1c} (%)		
N ^a	160	149
Mean at baseline (after randomization, Week 0)	7.6	7.6
Change from baseline (adjusted mean)	-0.5	0.0
Difference from Victoza® + metformin arm (adjusted mean) ^b	-0.5*	
95% Confidence Interval	(-0.7, -0.4)	
N ^a	160	149
Estimated proportion of patients achieving HbA _{1c} <7% ^c	43%	17%
Fasting Plasma Glucose (mmol/L)		
N ^a	160	154
Mean as baseline (after randomization, Week 0)	9.23	8.81
Change from baseline (adjusted mean) ^b	-2.12	-0.39
Body Weight (kg)		
N ^a	162	157
Baseline (after randomization, Week 0)	6	95.3
Change from baseline (adjusted mean) ^b	-0.16	-0.95

^a Intent-to-treat population using last observation on study. Subjects with no post-baseline measurements are excluded from analysis.

^b Least squares mean from an ANCOVA with treatment, country and previous OAD as factors and baseline value as a covariate

^c Estimates from a logistic regression model with treatment as fixed effect and baseline HbA_{1c} as covariate

*p-value <0.0001

Monotherapy (LEAD™ 3)

In this 52-week trial, 746 patients were randomized to Victoza® 1.2 mg (N=251), Victoza® 1.8 mg (N=247), or glimepiride 8 mg (N=248). Patients enrolled in this study were diagnosed with type 2 diabetes mellitus and previously treated with diet/exercise (N=272; 36.5%) or not more than half-maximal OAD monotherapy (N=474; 63.5%) for at least 2 months. Patients who were randomized to glimepiride were initially treated with 2 mg daily for two weeks, increasing to 4 mg daily for another two weeks, and finally increasing to 8 mg daily; patients who were randomized to Victoza® 1.2 mg or Victoza® 1.8 mg were initially treated with 0.6 mg daily and the dose was increased in weekly intervals by 0.6 mg to reach 1.2 mg or 1.8 mg. After the titration period, Victoza® and glimepiride doses remained fixed. Treatment with Victoza® 1.8 mg and 1.2 mg resulted in statistically significant mean reductions in HbA_{1c} compared to glimepiride (**Table 14**).

The mean age of the randomized subjects at baseline was 53 years and mean duration of

diabetes was 5.4 years, 49.7% were male. 77.5% were Caucasian and 12.6% African American. The mean BMI at baseline was 33.1 kg/m².

Table 14 Results of a 52-week monotherapy trial^a

	Victoza[®] 1.8 mg	Victoza[®] 1.2 mg	Glimepiride 8 mg
Intent-to-Treat Population (N)	246	251	248
HbA_{1c} (%) (Mean)			
Baseline	8.2	8.2	8.2
Change from baseline (adjusted mean) ^b	-1.1	-0.8	
Difference from glimepiride arm (adjusted mean) ^b	-0.6**	-0.3*	-0.5
95% Confidence Interval	(-0.8, -0.4)	(-0.5, -0.1)	
Percentage of patients achieving A1c <7%	51	43	28
Fasting Plasma Glucose (mmol/L) (Mean)			
Baseline	9.54	9.24	9.53
Change from baseline (adjusted mean) ^b	-1.42	-0.84	-0.29
Body Weight (kg) (Mean)			
Baseline	92.6	92.1	93.3
Change from baseline (adjusted mean) ^b	-2.5	-2.1	+1.1

^aIntent-to-treat population using last observation on study

^bLeast squares mean adjusted for baseline value

*p-value <0.05

**p-value <0.0001

Use in Patients with Type 2 Diabetes and Established Cardiovascular Disease (LEADER EX2211-3748)

The Liraglutide Effect and Action in Diabetes Evaluation of Cardiovascular Outcome Results trial (LEADER) was a large, long-term, multicentre, multi-national, randomized, double-blind, placebo-controlled, time and event-driven trial in adults with type 2 diabetes mellitus (T2DM) at high risk of cardiovascular disease. LEADER was a non-inferiority trial aimed to demonstrate that liraglutide compared to placebo did not contribute to a significant increase in cardiovascular risk in patients with T2DM. A total of 9,340 patients were randomized equally to Victoza[®] 1.8 mg or placebo in addition to standard of care. At baseline, patients were to be at least 50 years of age with established cardiovascular disease or chronic kidney disease (n=7,598; (81.3%); or 60 years of age with only risk factors of vascular disease (n=1,742; (18.7%).

At baseline, patients were allowed to be anti-diabetic drug naïve or treated with one or more oral anti-diabetic drugs (OAD) or insulin (either alone or in combination with OAD(s)). The Victoza[®] and placebo groups were generally balanced in terms of concomitant medications (anti-diabetic and cardiovascular medications including antihypertensives, diuretics, lipid-lowering, and platelet aggregation inhibitors). During the trial, additional anti-diabetic and cardiovascular medications were to be added according to standard of care to achieve individualized guideline targets for glycemic control, blood pressure, and lipids.

The primary endpoint was the time from randomization to first occurrence of any major adverse cardiovascular events (MACE), including cardiovascular death, non-fatal myocardial infarction, or non-fatal stroke. If non-inferiority was met for the primary endpoint, statistical superiority was subsequently tested.

Primary outcome or vital status at end of trial was available for 99.7% and 99.6% of participants

randomized to Victoza® and placebo, respectively. The median duration of exposure was 3.5 years and up to a maximum of 5 years. The mean age was 64 years and the mean BMI was 32.5 kg/m². The population was primarily male (64.3%), Caucasian (77.5%), with a mean duration of diabetes of 12.8 years and mean HbA_{1c} of 8.7%. Concomitant cardiovascular diseases of randomized patients primarily included history of myocardial infarction (30.1%), history of ischemic stroke (11.1%), NYHA class I (3.7%), NYHA class II (11.7%), NYHA class III (2.3%), hypertension/left ventricular hypertrophy (91.1%), and arrhythmia (15.4%). At baseline, 41.8% of patients had mild renal impairment, 20.7% had moderate renal impairment, and 2.4% had severe renal impairment.

According to hierarchical testing for non-inferiority and superiority for MACE, Victoza® was found to be:

- Non-inferior to placebo, since the upper bound of the 95% CI was below 1.3; and
- Statistically superior to placebo, since the upper bound of the 95% CI was also below 1.0.

The estimated hazard ratio was below 1.0 for MACE and all 3 individual components (**Figure 10**):

1. MACE (HR 0.87 [95% Confidence Interval (CI); 0.78, 0.97] ($p < 0.001$ for non-inferiority and $p = 0.005$ for superiority) (see **Figure 8** and **Figure 10**)
 - Cardiovascular death (HR 0.78 [95% CI; 0.66, 0.93])
 - Non-fatal myocardial infarction (HR 0.88 [95% CI; 0.75, 1.03])
 - Non-fatal stroke (HR 0.89 [95% CI; 0.72, 1.11]).

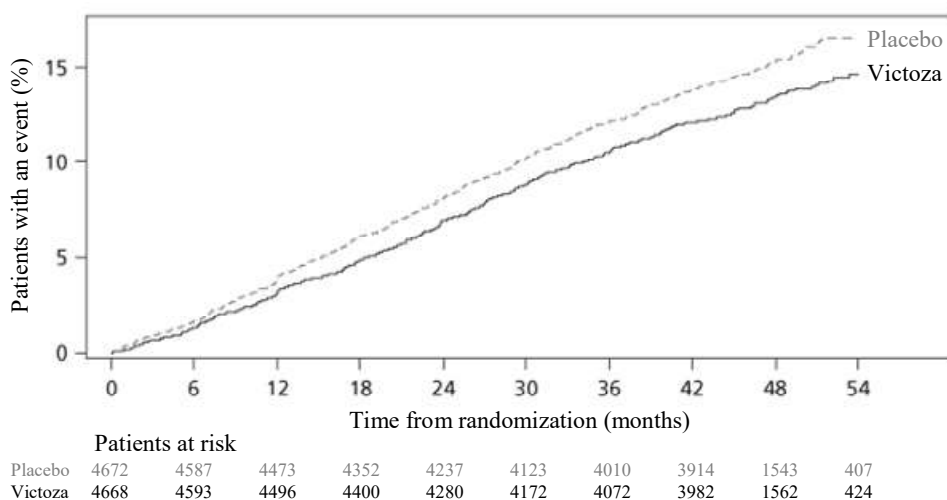

FAS: full analysis set.

Figure 8 Kaplan-Meier Plot Time to First MACE in subjects with T2DM at high risk of cardiovascular disease

The results for the primary endpoint stratified by the baseline cardiovascular risk demonstrated that for time to first MACE, subjects with established cardiovascular disease at baseline had an estimated hazard ratio of 0.83 [95% CI; 0.74, 0.93]; while subjects with only risk factors for cardiovascular disease at baseline had an estimated hazard ratio of 1.20 [95% CI; 0.86, 1.67]. In the subgroup with established cardiovascular disease, the treatment effect reflected a significant reduction in the incidence of cardiovascular death (HR 0.74 [95% CI; 0.61, 0.89])

(see Figure 9).

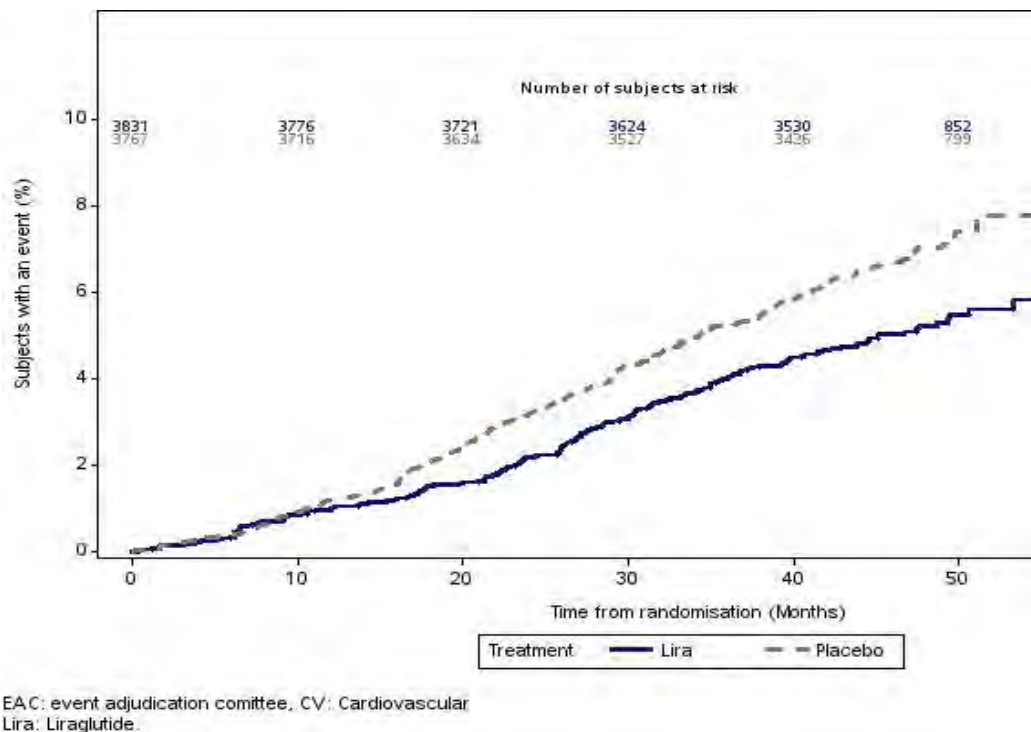
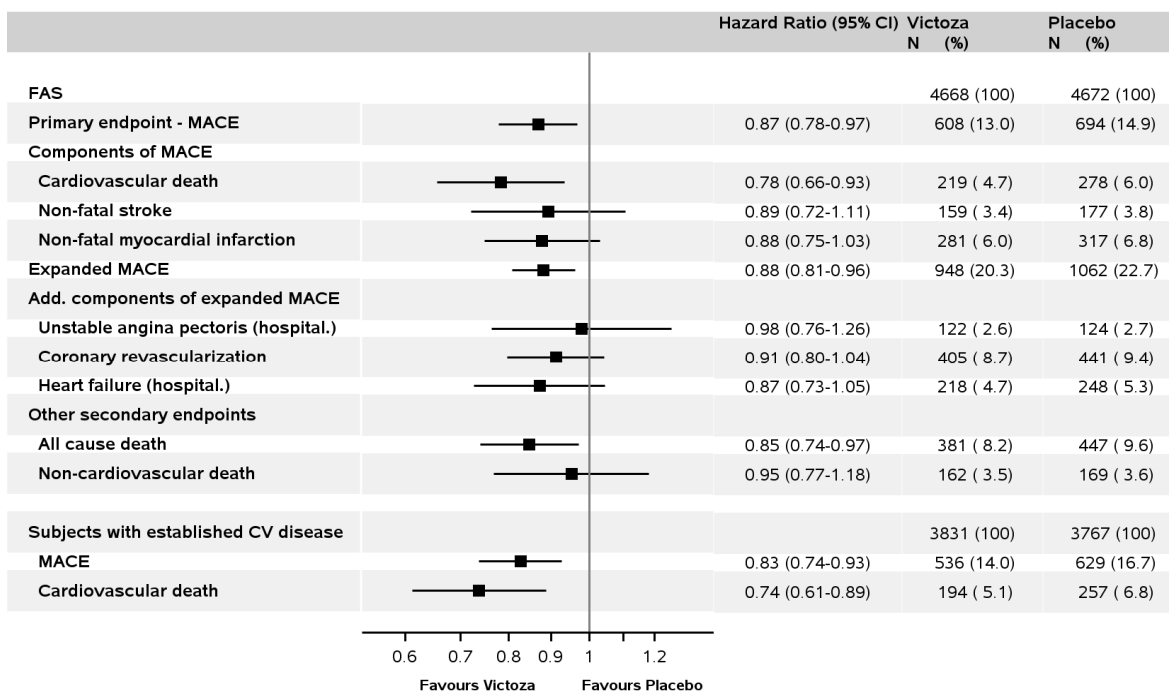

Figure 9 Kaplan-Meier plot of time to EAC confirmed cardiovascular death - subjects with established CV disease

Victoza[®] also significantly reduced the risk of expanded MACE (including MACE components, unstable angina pectoris leading to hospitalization, coronary revascularization, and hospitalization due to heart failure) in subjects with T2DM at high risk of cardiovascular disease, with an estimated hazard ratio of 0.88 [95% CI; 0.81, 0.96] ($p = 0.005$) (see **Figure 10**). The estimated hazard ratio of time to all-cause death for Victoza[®] compared to placebo was 0.85 [95% CI; 0.74, 0.96] ($p = 0.017$).

The change from baseline to month 36 for HbA_{1c} was -1.2% for Victoza[®]-treated patients and -0.8% for placebo-treated patients, corresponding to an estimated treatment difference of -0.4 [95% CI; -0.5, -0.3].



FAS: full analysis set, CI: confidence interval, MACE: major cardiovascular event, N: number of subjects with an event, %: percent of subjects with an event.

Figure 10 Forest Plot of Cardiovascular Endpoints

Type 2 Diabetes Mellitus patients with renal insufficiency:

In a double-blind trial comparing the efficacy and safety of liraglutide 1.8 mg versus placebo as add-on to insulin and/or OAD in patients with type 2 diabetes and moderate renal insufficiency, liraglutide was superior to placebo treatment in reducing HbA_{1c} after 26 weeks (-1.05% vs -0.38%). The estimated treatment difference was -0.66 (95% CI [-0.90, -0.43]), p<0.0001. The estimated mean change from baseline to Week 26 in body weight for the liraglutide group was -2.41 kg and for the placebo group was -1.09 kg.

Glycemic Control Trial in Patients 10 Years of Age and Above with Type 2 Diabetes Mellitus:

Victoza[®] was evaluated in a 26-week, double-blind, randomized, parallel group, placebo controlled multi-center trial in 134 pediatric patients with type 2 diabetes aged 10 years and above. Patients were randomized to Victoza[®] once-daily or placebo once-daily in combination with metformin with or without basal insulin treatment. Overall, 18.7% of patients were using basal insulin at baseline. All patients were on a metformin dose of 1000 to 2000 mg prior to randomization. The basal insulin dose was decreased by 20% at randomization and Victoza[®] was titrated weekly by 0.6 mg for 2 to 3 weeks based on tolerability and an average fasting plasma glucose goal of < 6.1 mmol/L. Based on adequate glycaemic control or tolerability, 30% of trial subjects remained on a dose of 0.6 mg and 70% of trial subjects remained on 1.2 mg or 1.8 mg.

At week 26, treatment with Victoza[®] was superior in reducing HbA_{1c} from baseline versus placebo. The estimated treatment difference in HbA_{1c} reduction from baseline between Victoza[®] and placebo was -1.06% with a 95% confidence interval of [-1.65%; -0.46%] (see **Table 15**).

Table 15 Results at Week 26 in a Trial Comparing Victoza® in combination with metformin with or without basal insulin to Placebo in combination with metformin with or without basal insulin in Pediatric Patients 10 Years of Age and Above with Type 2 Diabetes Mellitus

	Victoza® + metformin ± basal insulin	Placebo + metformin ± basal insulin
N	66	68
HbA_{1c} (%)		
Baseline	7.9	7.7
End of 26 weeks (LOCF)	7.1	8.2
Adjustment mean change from baseline after 26 weeks ^a	-0.64	0.42
Treatment difference [95% CI] Liraglutide 1.8 mg vs Placebo	-1.06 [-1.65; -0.46]*	
Percentage of patients achieving A1c <7% ^b	63.7	36.5
FPG (mmo/L)(Mean)		
Baseline	8.70	8.15
End of 26 weeks	7.342	9.220
Adjustment mean change from baseline after 26 weeks ^a	-1.076	0.801
Treatment difference [95% CI] Liraglutide 1.8 mg vs Placebo	-1.878 [-3.093; -0.662]	

^a The change from baseline to end of treatment visit in HbA_{1c} and FPG was analysed using a pattern mixed model (PMM) of observed data with missing observations imputed from the placebo arm based on multiple (x10,000) imputations. The data for week 26 were then analysed with an ANCOVA model containing treatment, sex and age group as fixed effects and baseline value as covariate.

^bThe response status is derived from the continuous endpoint (HbA_{1c}) using a PMM with multiple imputation for missing observations.

* p-value <0.001

16 NON-CLINICAL TOXICOLOGY

Single dose toxicity

Single dose studies were performed in mice and rats in standard design studies and in monkeys in a maximum tolerated dose (MTD) study. A single dose of 10 mg/kg was generally well tolerated by mice and rats without mortality. In monkeys, a single s.c. administration of 5 mg/kg was well tolerated without mortality. The observed reductions in body weight and food consumption can be regarded as pharmacologically mediated.

Repeat dose toxicity

Pivotal repeat dose studies were performed in mice, rats and Cynomolgus monkeys. An overview of the toxicological programme can be found in the tables below:

Table 16

Study ID	NN203261	NN204082
Species/strain	CD-1 mice	CD-1 mice
Drug	Liraglutide	Liraglutide
Dose Route	s.c.	s.c.
Animals/sex/group	Main study: 5 groups:10 males, 10 females/group Satellite study: 5 groups:16 males, 16 females/group	Main study: 4 groups:10 males, 10 females/group Satellite study: 4 groups:28 males, 28 females/group Antibody study: 4 groups 5-15 males, 5-15 females/group
Dose groups (mg/kg/day)	0, 0.1, 0.5, 1.0, 5.0	0, 0.2, 1.0, 5.0
Duration	4 weeks	13 weeks
NOEL/ NOAEL (mg/kg/day)	NOEL <0.1mg/kg NOAEL 5 mg/kg	NOEL < 0.2 mg/kg NOAEL <0.2 mg/kg

Study ID	NN980183	NN980189	NN200239
Species Strain	Rats/Sprague Dawley	Rats/Sprague Dawley	Rats/Sprague Dawley
Drug	Liraglutide	Liraglutide	Liraglutide
Dose Route	s.c	s.c.	s.c.
Animals/Sex/Group	Main study: 4 groups: 10 males, 10 females/group Satellite study: 3 groups: 10 males, 10 females/group.	Main study: 4 groups: 10 males, 10 females/group Satellite study: 4 groups: 10 males, 10 females/group. Recovery study: 2 groups: 5 males, 5 females/group	4 groups: 15 males, 15 females/group
Dose Groups (mg/kg/day)	0, 0.1, 0.25, 1.0	0, 0.1, 0.25, 1.0	0, 0.1, 0.25, 1.0
Duration	4 weeks	13 weeks treatment + 4 weeks recovery	26 weeks
NOEL/ NOAEL (mg/kg/day)	NOEL <0.1 mg/kg NOAEL 1.0 mg/kg	NOEL <0.1 mg/kg NOAEL 1.0 mg/kg	NOEL <0.1 mg/kg NOAEL 1.0 mg/kg

Study ID	NN980184	NN990191	NN200241
Species/strain	Cynomolgus Monkeys	Cynomolgus Monkeys	Cynomolgus Monkeys
Drug	Liraglutide	Liraglutide	Liraglutide
Dose Route	s.c.	s.c.	s.c.
Animals/sex/group	4 groups: 3 males, 3 females/group	Main study: 4 groups: 4 males, 4 females/group. Recovery study: 2 groups: 2 males, 2 females/group	Main study: 4 groups: 4 males, 4 females/group. Recovery study: 2 groups: 2 males, 2 females/group
Dose groups (mg/kg/day)	0, 0.05, 0.5, 5.0	0, 0.05, 0.5, 5.0	0, 0.05, 0.5, 5.0
Duration	4 weeks	13 weeks treatment + 2 weeks recovery	52 weeks treatment + 4 weeks recovery
NOEL/ NOAEL (mg/kg/day)	NOEL < 0.05 mg/kg NOAEL 5 mg/kg	NOEL < 0.05 mg/kg NOAEL 5 mg/kg	NOEL 0.05 mg/kg NOAEL 5 mg/kg

In mice, rats and monkeys, decreased body weight gain and food consumption were seen during the first weeks of dosing which was attributed to the pharmacological action of liraglutide. Subsequently, body weight gain and food consumption were generally comparable to that of the control group. For all species, there were no toxicologically significant effects noted on hematology, clinical chemistry and urinary parameters. However, for mice only, histopathological examination of the thyroid gland revealed C-hyperplasia at all dose levels, first event after 9 weeks of treatment. Effects on C-cells (focal accumulations of C-cells) were already seen in the 4-week mouse study but these findings were not considered to be treatment-related. No effects on C-cells were seen in the rat and monkey studies up to 26 and 52 weeks.

An increase in pancreatic weight was observed at all dose levels, in male cynomolgus monkeys in the 28-day study and following 52 weeks treatment in both sexes. Further investigations of the pancreatic tissues collected in the 52-week monkey study showed that the increased pancreatic weight was due to a 67% increase in absolute duct cell mass and 64% increase in exocrine cells when compared to the vehicle group. However, normal histological morphology of the pancreas was seen in all studies and no clinical or biochemical changes were seen in any of the 4 non-human primate studies. In addition, no effect on pancreatic weight was observed in an 87-week mechanistic study conducted in cynomolgus monkeys.

Carcinogenicity

A 104-week carcinogenicity study was conducted in male and female mice at doses of 0.03, 0.2, 1.0, 3.0 mg/kg/day administered by subcutaneous bolus injection. The human exposure multiple (based on plasma AUC₀₋₂₄ comparison) values for the 0.03, 0.2, 1 and 3 mg/kg/day doses were 0.2, 1.8, 10.0 and 45.0, respectively. Treatment resulted in an increased incidence of focal C-cell hyperplasia for males and females dosed at 1.0 and 3.0 mg/kg/day, and for females dosed at 0.2 mg/kg/day, incidence rates for the 0, 0.03, 0.2, 1.0 and 3.0 mg/kg/day groups respectively, were 0%, 0%, 1.5%, 16.4% and 38.0% for males, and 0%, 0%, 10.4%, 10.5% and 33.3% for females. There was also a dose-related increase in benign thyroid C-cell adenomas in the 1.0 and the 3.0 mg/kg/day groups with incidences of 13% and 19% in males and 6% and 20% in females, respectively, C-cell adenomas did not occur in control groups or in the 0.03 and 0.2 mg/kg/day groups. Treatment-related malignant C-cell carcinomas occurred in 3% of females in the 3.0mg/kg/day group. Thyroid C-cell tumours are rare findings during carcinogenicity testing in mice. In addition, there was a treatment-related increase in fibrosarcomas on the dorsal skin and subcutis, the body surface used for drug injection, in

males in the 3 mg/kg/day group. These fibrosarcomas were attributed to the high local concentration of drug near the injection site. The liraglutide concentration in the clinical formulation (6 mg/mL) is 10-times higher than the concentration in the formulation used to administer 3 mg/kg/day liraglutide to mice in the carcinogenicity study (0.6 mg/mL). The NOAEL for this study is 0.03 mg/kg/day.

A 104-week carcinogenicity study was conducted in male and female rats at doses of 0.075, 0.25 and 0.75 mg/kg/day administered by bolus subcutaneous injection with exposures 0.5, 2.2 and 7.6 times the human exposure level, respectively, based on plasma AUC₀₋₂₄ comparison. There was a treatment-related increase in the incidence and severity of focal C-cell hyperplasia in the 0.25 and 0.75 mg/kg/day groups, incidence rates for the 0, 0.075, 0.25 and 0.75 mg/kg/day, respectively, were 22%, 29%, 40% and 48% for males, and 28%, 29%, 55% and 48% for females. In addition, there was a treatment-related increase in benign thyroid C-cell adenomas noted for males in the 0.25 and 0.75 mg/kg/day groups with incidences of 12%, 16%, 42% and 46% for females in all treated groups with incidences of 10%, 27%, 33% and 56% in the 0 (control), 0.075, 0.25, and 0.75 mg/kg/day groups, respectively. A treatment-related increase in malignant thyroid C-cell carcinomas was observed in all male liraglutide-treated groups with incidences of 2%, 8%, 6% and 14% and in females at 0.25 and 0.75 mg/kg/day with incidences of 0%, 0%, 4%, and 6% in 0 (control), 0.075, 0.25 and 0.75 mg/kg/day groups, respectively. Thyroid C-cell carcinomas are rare findings during carcinogenicity testing in rats. The NOAEL for this study is <0.075 mg/kg/day.

The human relevance of thyroid C-cell tumours observed in rats and mice is unknown and could not be determined based on the results of the nonclinical studies (refer to SERIOUS WARNINGS AND PRECAUTIONS BOX; and WARNINGS AND PRECAUTIONS, Carcinogenesis and Mutagenesis).

Mutagenesis

Liraglutide was not mutagenic or clastogenic with or without metabolic activation in the following tests: Ames test, human peripheral blood lymphocyte chromosome aberration test, and in vivo micronucleus test in the rat.

Reproduction

In a rat fertility and embryo-fetal developmental study, rats were administered liraglutide subcutaneously at doses of 0.1, 0.25 and 1.0 mg/kg/day. Males were treated for 4 weeks prior to and throughout mating and females were treated 2 weeks prior to and throughout mating until gestation day 17. No direct adverse effects on male fertility were observed up to the highest dose levels tested which represented, a systemic exposure 11 times the human exposure based on plasma AUC. Body weight gain and food intake were transiently reduced at all dose levels. At 1.0 mg/kg/day there was an increased incidence of early embryonic death, and an increase in the number of fetuses and litters with minimally kinked ribs. The fetal NOAEL/NOEL was therefore considered to be 0.25 mg/kg/day.

In a rabbit developmental study, pregnant females were administered liraglutide subcutaneously at doses of 0.01, 0.025 and 0.05 mg/kg/day from gestation day 6 through day 18 inclusive. The estimated systemic exposures were less than the human exposure at all doses, based on plasma AUC. Fetal weight was decreased and the incidence of total major fetal abnormalities was increased at all dose levels tested. Single cases of microphthalmia were noted at all dose levels. Since microphthalmia is a very rare malformation, and was not observed in the control group, or in any of the historical control groups, this finding is considered to be related to treatment. In addition, there was an increase in the fetal incidence of connected parietals in the

high dose group, and a single case of split sternum in the 0.025 and 0.05 mg/kg/day groups which could not be ruled out as unrelated to treatment. Minor abnormalities considered to be treatment related were an increase in the incidence of jugal(s) connected/fused to maxilla at all dose levels and an increase in the incidence of bilobed/bifurcated gallbladder at 0.025 and 0.50 mg/kg/day. The noted findings exceeded the incidence noted in the concurrent and historical controls. Based on these data, a NOEL/NOAEL for embryo/fetal toxicity could not be determined. Liraglutide is considered to be a possible teratogen in rabbits due to the increased incidence of major abnormalities noted at all dose levels tested.

In a pre- and post-natal study, pregnant female rats were administered subcutaneous doses of 0.1, 0.25 and 1.0 mg/kg/day liraglutide from gestation day 6 through weaning or termination of nursing on lactation day 24. Estimated systemic exposures were 0.8-, 3-, and 11-times human exposure, based on plasma AUC. Reduced body weight gain/weight loss, and decreased food consumption were observed in all treated groups, evident primarily during the first 3 days of dosing. At 1.0 mg/kg/day, following the initial weight loss, the difference in absolute weight when compared to controls, was not recovered by the end of gestation. Lesser effects were noted at the lower dose levels. In addition, decreased weight gain was evident in F₀ females that had been treated with 1.0 mg/kg/day, between Days 1 and 14 of lactation. Litter size and survival were similar in all groups, but decreased weight gain was evident in the F₁ pups prior to weaning, at all dose levels.

The reduced body weight of F₁ pups persisted in the post-weaning period, but only at 1.0 mg/kg/day was there also a reduction in weight gain, which was noted for females during lactation and for males.

There were no apparent treatment-related effects on the development, behaviour, physiology or reproductive function of the F₁ animals, except for a slight reduction in body weights of F₂ pups at 1.0 mg/kg/day.

In a juvenile toxicity study, subcutaneous doses of 0, 0.05, 0.25 or 1.0 mg/kg/day of liraglutide (0.4, 2.7 and 8.5 fold the human exposure of that in pediatric patients 10-17 years of age) were administered to rats from postnatal day 21 to day 90. As in other studies, lower body weight gain, body weights, and food consumption were observed in juvenile animals administered liraglutide when compared to control animals. Liraglutide also caused a decrease in ulna growth and ulna length which completely recovered off treatment and a delay in sexual maturation in both sexes at 0.25 and 1.0 mg/kg/day. Slightly longer estrous cycles which recovered off treatment, slightly lower implantation counts and post-partum litter size following mating were also observed at 1 mg/kg/day in females, for which a relationship to treatment could not be discounted. The NOAEL for juvenile rats was therefore considered to be 0.05 mg/kg/day.

READ THIS FOR SAFE AND EFFECTIVE USE OF YOUR MEDICINE
PATIENT MEDICATION INFORMATION

PrVictoza[®]
liraglutide injection

Read this carefully before you start taking **Victoza[®]** and each time you get a refill. This leaflet is a summary and will not tell you everything about this drug. Talk to your healthcare professional about your medical condition and treatment and ask if there is any new information about **Victoza[®]**.

Serious Warnings and Precautions

Possible Risk of thyroid tumours, including cancer

As part of drug testing, liraglutide, the active ingredient in **Victoza[®]** was given to rats and mice in long term studies. In these studies, liraglutide caused both rats and mice to develop medullary thyroid tumours, some of which were cancer. It is not known if **Victoza[®]** will cause thyroid tumours or a type of thyroid cancer called medullary thyroid cancer in people. Medullary thyroid cancer in humans is rare; however, it is serious and potentially fatal. If you develop tumours of the thyroid, it may have to be surgically removed. You should discuss any safety concerns you have about the use of **Victoza[®]** with your doctor.

What is **Victoza[®] used for?**

- **Victoza[®]** is used in combination with metformin, with metformin and a sulfonyleurea, with metformin and a sodium glucose cotransporter 2 inhibitor (SGLT2i), or basal insulin to improve blood sugar levels in adults with type 2 diabetes.
- **Victoza[®]** is used in combination with metformin with or without basal insulin to improve blood sugar levels in adolescents and children aged 10 years and above with type 2 diabetes.
- **Victoza[®]** may be used on its own if your blood sugar is not properly controlled by diet and exercise alone and you cannot use metformin.
- If you have type 2 diabetes and have a history of heart disease (such as a past heart attack, heart failure, or stroke), **Victoza[®]** can be used along with diet and exercise to lower your risk of dying from events related to your heart or blood vessels.
- **Victoza[®]** should not be used in type 1 diabetes (formerly known as insulin-dependent diabetes mellitus or IDDM).

How does **Victoza[®] work?**

Victoza[®] belongs to a class of medicines called GLP-1 analogue. **Victoza[®]** helps your body to make more insulin when your blood sugar is high.

What is type 2 diabetes?

Type 2 diabetes is a condition in which your body does not make enough insulin, and/or does not use the insulin that your body produces as well as it should. When this happens, sugar (glucose) builds up in the blood. This can lead to serious problems.

What are the ingredients in **Victoza[®]?**

Medicinal ingredients: Liraglutide

Non-medicinal ingredients: Disodium phosphate dihydrate, propylene glycol, phenol and water for injections

Victoza® comes in the following dosage forms:

Pre-filled multidose pen that can deliver 30 doses of 0.6 mg, 15 doses of 1.2 mg or 10 doses of 1.8 mg.

Do not use Victoza® if:

- You or a member of your family has ever had medullary thyroid cancer.
- You have Multiple Endocrine Neoplasia syndrome type 2 (MEN 2).
- You are allergic to any of the ingredients in Victoza®.
- You are pregnant or breastfeeding.

To help avoid side effects and ensure proper use, talk to your healthcare professional before you take Victoza®. Talk about any health conditions or problems you may have, including if you:

- Or a member of your family has or has had medullary thyroid carcinoma, or if you have Multiple Endocrine Neoplasia syndrome type 2 (MEN 2).
- Have type 1 diabetes.
- Have ever had diabetic ketoacidosis (increased ketones in the blood or urine).
- Have ever had an allergic reaction to Victoza®.
- Have a high heart rate (fast pulse).
- Have a condition called heart block.
- Have any heart disease, such as angina, heart rhythm disturbances or congestive heart failure; or if you have ever had a myocardial infarction (heart attack).
- Have kidney problems.
- Have liver problems.
- Have gastrointestinal (digestive) problems.
- Have ever had pancreatitis.
- Are breastfeeding or plan to breastfeed.
- Are pregnant or plan to become pregnant.
- Have severe vomiting and/or diarrhea and/or dehydration.

When initiating treatment with Victoza®, you may in some cases experience loss of fluids/dehydration, e.g. in case of vomiting, nausea and diarrhea. It is important to avoid dehydration by drinking plenty of fluids. Worsening of renal function may sometimes require hemodialysis. Contact your doctor if you have any questions or concerns.

Victoza® may increase heart rate and could cause changes known as PR prolongation, which are detected by electrocardiogram (ECG) tracings. Increased heart rate is the same as a faster pulse. Rarely, drugs with these effects can cause changes in heart rhythm that could result in dizziness, palpitations (a feeling of rapid, pounding, or irregular heart beat), fainting or death. These heart rhythm changes are more likely if you have heart disease, or if you are taking certain other drugs. It is important to follow your doctor's advice about the dose of Victoza® or about any special tests that you may need. See '*What are possible side effects from using Victoza®?*'

Victoza® is not recommended for use in children under 10 years of age.

Tell your healthcare professional about all the medicines you take, including any drugs,

vitamins, minerals, natural supplements or alternative medicines.

In particular, tell your doctor, Diabetes Nurse Educator or pharmacist if you are using any of the following medicines for diabetes:

- A sulfonylurea medicine (such as glibenclamide or glimepiride). This is because using Victoza[®] at the same time may cause your blood sugar to get too low (hypoglycemia).
- When you first start using these medicines together, your doctor may tell you to lower the dose of the sulfonylurea medicine.
- Insulin. You may get hypoglycemia (low blood sugar) when using Victoza[®] with insulin as insulin increases the risk of hypoglycemia. See '*What are possible side effects from using Victoza[®]?*'
- If you are not sure if the medicines you are taking contain a sulfonylurea, ask your doctor, Diabetes Nurse Educator or pharmacist.

The following may interact with Victoza[®]:

The following list includes some, but not all, of the drugs that may increase the risk of heart rhythm problems while receiving Victoza[®]. You should check with your doctor or pharmacist before taking any other medication with Victoza[®]:

- Drugs to treat hypertension
- Drugs to treat heart failure
- Drugs to treat HIV infection
- Drugs to treat attention deficit-hyperactivity disorder
- Drugs to suppress appetite/cause weight loss
- Decongestants
- Drugs to treat asthma

How to take Victoza[®]:

Take Victoza[®] exactly as your doctor has prescribed.

Victoza[®] is an injection which is given under the skin (subcutaneously). Do not inject it into a vein or muscle.

Before you use the pen for the first time, your doctor or Diabetes Nurse Educator will show you how to use it. The best places to give yourself the injection are the front of your thighs, the front of your waist (abdomen) or your upper arm. You can give yourself the injection at any time of the day. (see '*Instructions for using the Victoza[®] (liraglutide injection) pen*').

Do not share your Victoza[®] pen with anyone else, even if the needle is changed. Do not reuse or share needles with another person including family members. You may give another person an infection or get an infection from them.

Usual dose:

Victoza[®] can be taken at any time of the day. It does not matter when you take it in relation to meals.

The usual starting dose is 0.6 mg once a day. Your doctor will tell you how long to keep taking this dose. It will be for at least one week. Your dose may be increased to 1.2 mg once a day if your blood glucose is not under control. If your blood glucose is not controlled with a dose of 1.2 mg, your doctor may tell you to increase the dose to 1.8 mg once a day. Do not change your dose unless your doctor has told you to.

You will not need to test your blood sugar levels each day in order to adjust your dose of Victoza[®]. However, if you are taking a sulfonylurea medicine as well as Victoza[®], your doctor may advise you to test your blood sugar levels. This will help your doctor to decide if the dose of the sulfonylurea needs to be changed.

For children and adolescents starting Victoza[®], your doctor may advise you to test your blood sugar levels to monitor for hypoglycemia (low blood sugar).

Overdose:

If you think you have taken too much Victoza[®], contact your healthcare professional, hospital emergency department or regional poison control centre immediately, even if there are no symptoms.

If you use more Victoza[®] than you should, talk to your doctor straight away. You may need medical treatment. If you use too much Victoza[®] you may feel sick (have nausea), become sick (vomit), or experience low blood sugar (hypoglycemia). Please refer to '*Common (affects less than 1 in 10 people)*' for early warning signs of low blood sugar.

Missed Dose:

If a dose of Victoza[®] is missed take your dose on the next day as usual. Do not take an extra dose or increase the dose on the following day to make up for the missed dose.

Do not stop using Victoza[®] without talking to your doctor. If you stop using it, your blood sugar levels may increase.

What are possible side effects from using Victoza[®]?

These are not all the possible side effects you may feel when taking Victoza[®]. If you experience any side effects not listed here, contact your healthcare professional.

Like all medicines, Victoza[®] can cause side effects. The following side effects may happen with this medicine.

Very common (affects more than 1 in 10 people)

- Feeling sick (nausea). This usually goes away over time.
- Diarrhea

Common (affects less than 1 in 10 people)

- Low blood sugar (hypoglycemia). This is usually mild. It is more likely if you are also taking a medicine for diabetes called a sulfonylurea. The warning signs of low blood sugar may come on suddenly. They can include: cold sweat, cool pale skin, headache, fast heart beat, feeling sick, feeling very hungry, changes in vision, feeling sleepy, feeling weak, nervous, anxious, or confused, difficulty concentrating, shaking (tremor). Your doctor will tell you how to treat low blood sugar and what to do if you notice these warning signs. If you are already taking a sulfonylurea medicine when you start using Victoza[®], your doctor may tell you to reduce the dose of the sulfonylurea. While you are driving or using tools or machines, you should avoid getting low blood sugar (hypoglycemia), because this may reduce your ability to concentrate.
- Anorexia
- Decreased appetite
- Headache
- Being sick (vomiting)
- Burping
- Indigestion
- Inflamed stomach (gastritis). The signs include stomach pain, feeling sick (nausea) and being sick (vomiting)
- Gastro-esophageal reflux disease (GERD). The signs include heartburn.
- Painful or swollen tummy (abdomen)
- Constipation
- Wind (flatulence)
- Infection of the upper airways
- Injection site reactions (such as bruising, pain irritation, itching and rash)
- Increased heart rate
- Gallstones
- Inflamed gallbladder (upper abdominal pain after eating, nausea, bloating and indigestion, especially after consuming a fatty meal)

Uncommon (affects less than 1 in 100)

- Urticaria (a type of skin rash)

If any of the side effects do not go away or get worse, or if you notice any side effects not listed in the leaflet, please tell your doctor, Diabetes Nurse Educator or pharmacist.

Serious side effects and what to do about them			
Symptom / effect	Talk to your healthcare professional		Stop taking drug and get immediate medical help
	Only if severe	In all cases	
UNCOMMON Chest pain or symptoms of a possible heart rhythm disturbance / dizziness, palpitations, fainting or seizures, you should seek immediate medical attention		✓	✓
RARE Pancreatitis / persistent, severe abdominal pain with or without vomiting		✓	
Severe hypoglycemia / disorientation, loss of consciousness, and seizures		✓	✓
Severe form of allergic reaction (anaphylactic reaction) with symptoms of breathing problems, swelling of throat and face, and fast heart beat. You should seek immediate medical attention		✓	✓
Cases of inflammation of the pancreas (pancreatitis). Pancreatitis can be a serious, potentially life-threatening medical condition. Stop taking Victoza® and contact your doctor immediately, if you notice any of the following serious side effects: severe and persistent pain in the abdomen (stomach area) which might reach through your back, as well as nausea and vomiting, as it could be a sign of an inflamed pancreas (pancreatitis).		✓	✓
VERY RARE Thyroid tumour / lump in the neck, difficulty in swallowing, difficulty in breathing or persistent hoarseness		✓	

If you have a troublesome symptom or side effect that is not listed here or becomes bad enough to interfere with your daily activities, talk to your healthcare professional.

Reporting Side Effects

You can report any suspected side effects associated with the use of health products to Health Canada by:

- Visiting the Web page on [Adverse Reaction Reporting](http://www.hc-sc.gc.ca/dhp-mps/medeff/report-declaration/index-eng.php) (<http://www.hc-sc.gc.ca/dhp-mps/medeff/report-declaration/index-eng.php>) for information on how to report online, by mail or by fax; or
- Calling toll-free at 1-866-234-2345.

NOTE: Contact your health professional if you need information about how to manage your side effects. The Canada Vigilance Program does not provide medical advice.

Storage:

Keep out of reach and sight of children.

Do not use Victoza[®] after the expiry date which is stated on the label and carton. The expiry date refers to the last day of that month.

- Before you start to use Victoza[®], store it in a refrigerator (2°C-8°C) away from the freezer compartment. Do not freeze it.
- When Victoza[®] is being used, you can keep it for 1 month either at room temperature (not above 30°C) or in a refrigerator (2°C-8°C).
- Do not use Victoza[®] if it has been frozen.
- Do not use Victoza[®] if it is not clear and colourless.
- Always remove the injection needle after each injection and store your Victoza[®] pen without an injection needle attached. This prevents contamination, infection, and leakage. It also ensures that the dosing is accurate.
- When you are not using the pen, keep the cap on. This will protect the medicine from light.
- Protect Victoza[®] from high temperatures and sunlight.
- Medicines should not be disposed of via waste water or household waste. Ask your pharmacist how to dispose of medicines no longer required. These measures will help to protect the environment.

If you want more information about Victoza[®]:

- Talk to your healthcare professional
- Find the full product monograph that is prepared for healthcare professionals and includes this Patient Medication Information by visiting the [Health Canada website](#); the manufacturer's website www.novonordisk.ca, or by calling Novo Nordisk Canada Inc., at 1-800-465-4334.

This leaflet was prepared by Novo Nordisk Canada Inc.

Last Revised May 2020

© 2020

Novo Nordisk Canada Inc.

Victoza[®], Levemir[®], NovoFine[®] and NovoTwist[®] are trademarks of Novo Nordisk A/S and used under license by Novo Nordisk Canada Inc.

Instructions for using the Victoza® (liraglutide injection) pen

Please read these instructions carefully before using your Victoza® pen.

Your Victoza® pen comes with 18 mg of liraglutide. You can select doses of 0.6 mg, 1.2 mg and 1.8 mg. Victoza® pen is designed to be used with NovoFine® disposable needles up to a length of 8 mm and as thin as 32G.

Do not share your Victoza® pen with another person, even if the needle is changed. Do not reuse or share needles with another person including family members. You may give another person an infection, or get an infection from them.

Victoza® pen

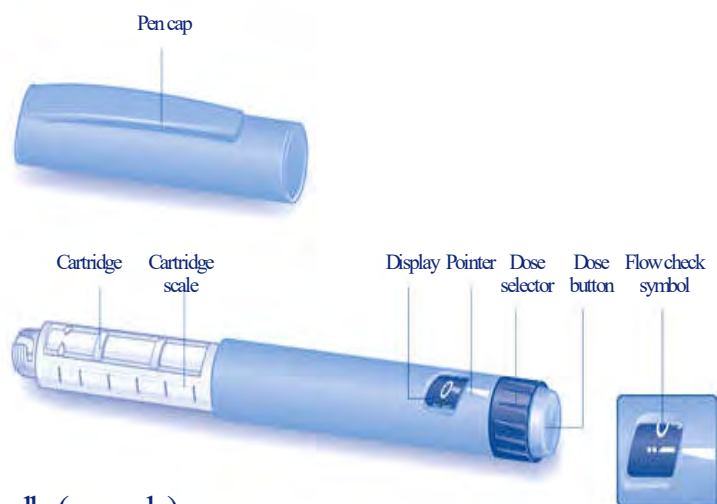

Needle (example)

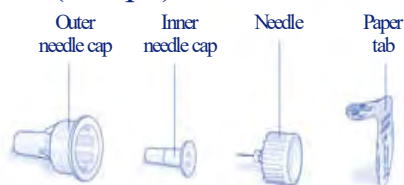

Preparing your Victoza® pen

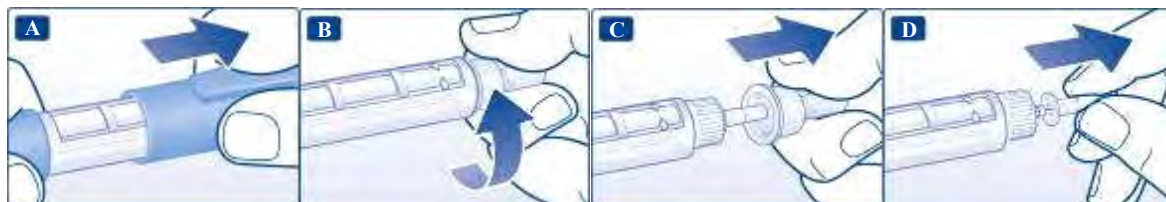

Check the name and coloured label of your pen to make sure that it contains liraglutide. Using the wrong medicine could cause severe harm.

A. Pull off the pen cap.

- B. Pull off the paper tab from a new disposable needle. Screw the needle straight and tightly onto your pen.
- C. Pull off the outer needle cap and keep it for later.
- D. Pull off the inner needle cap and throw it away.

- ⚠ **Always use a new needle for each injection. This reduces the risk of** contamination, infection, leakage of liraglutide, blocked needles and inaccurate dosing. Do not reuse or share needles with another person.
- ⚠ Be careful not to bend or damage the needle.
- ⚠ Never put the inner needle cap back on when you have removed it from the needle. This reduces the risk of hurting yourself with the needle.

With each new pen, check the liraglutide flow

Always check the liraglutide flow before your first injection with each new pen as follows. If your pen is already in use, go to “Select your dose” Step H.

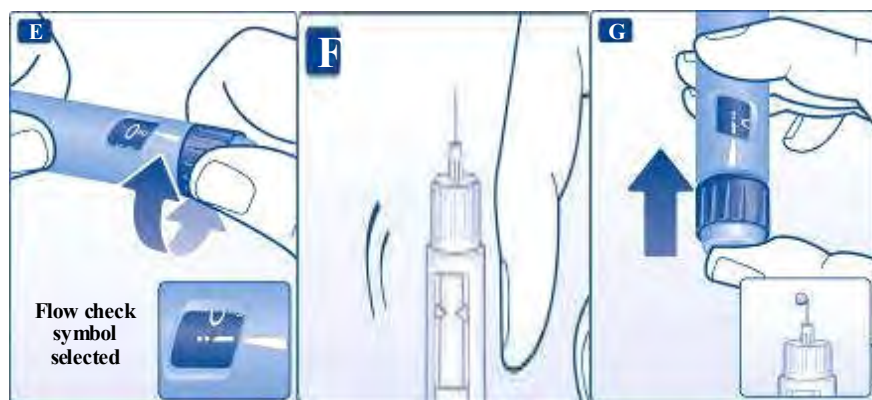

- E. Turn the dose selector until the flow check symbol lines up with the pointer.
 - F. Hold the pen with the needle pointing up. Tap the cartridge gently with your finger a few times. This will make any air bubbles collect at the top of the cartridge.
 - G. Keep the needle pointing up and press the dose button until 0 mg lines up with the pointer. A drop of liraglutide should appear at the needle tip. If no drop appears, repeat steps **E** to **G** up to four times. If there is still no drop of liraglutide, change the needle and repeat steps **E** to **G** once more. Do not use the pen if a drop of liraglutide still does not appear. This indicates the pen is defective and you must use a new one.
- ⚠ If you have dropped your pen against a hard surface or suspect that something is wrong with it, always put on a new disposable needle and check the flow before you inject.

Selecting your dose

Always check that the pointer lines up with 0 mg.

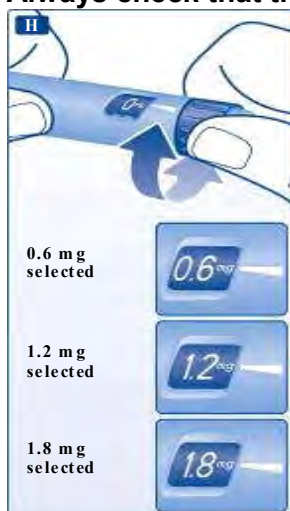

- H. Turn the dose selector until your needed dose lines up with the pointer (0.6 mg, 1.2 mg or 1.8 mg).

If you selected a wrong dose by mistake, simply change it by turning the dose selector backwards or forwards until the right dose lines up with the pointer. Be careful not to press the dose button when turning the dose selector backwards, as liraglutide may come out.

If the dose selector stops before your needed dose lines up with the pointer, there is not enough liraglutide left for a full dose. Then you can either:

Divide your dose into two injections:

Turn the dose selector in either direction until 0.6 mg or 1.2 mg lines up with the pointer. Inject the dose. Prepare a new pen for injection and inject the remaining number of mg to complete your dose.

You may only split your dose between your current pen and a new pen if trained or advised by your healthcare professional. Use a calculator to plan the doses. If you split the dose wrong, you may inject too much or too little liraglutide.

Inject the full dose with a new pen:

If the dose selector stops before 0.6 mg lines up with the pointer, prepare a new pen and inject the full dose with the new pen.

- ⚠ The dose selector clicks when you turn it. You must not use these clicks to select the amount of liraglutide to inject.
- ⚠ Do not use the cartridge scale to measure how much liraglutide to inject – it is not accurate enough.
- ⚠ Do not try to select other doses than 0.6 mg, 1.2 mg or 1.8 mg. The numbers in the display must line up precisely with the pointer to ensure that you get a correct dose.

Using your injection

Insert the needle into your skin using the injection technique shown by your doctor or nurse. Then follow the instructions below:

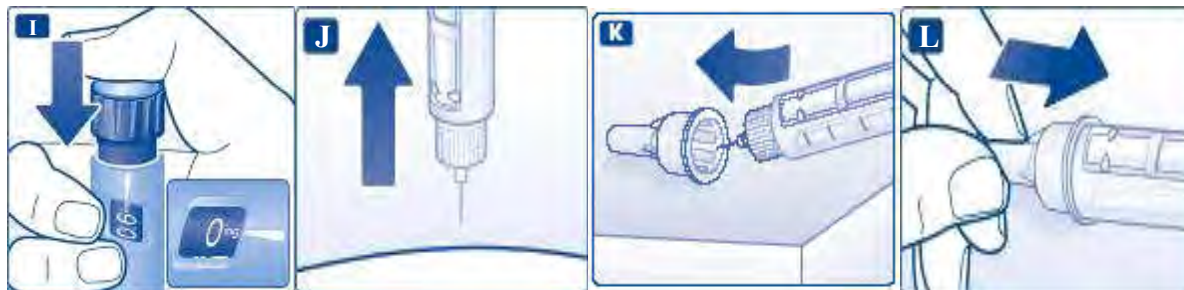

- I. Press the dose button to inject until 0 mg lines up with the pointer. Be careful not to touch the display with your other fingers or press the dose selector sideways when you inject. This is because it may block the injection. Keep the dose button pressed down and leave the needle under the skin for at least six seconds. This is to make sure that you get your full dose.
- J. Pull out the needle.
After that, you may see a drop of liraglutide at the needle tip.
This is normal and has no effect on the dose you have just had.
- K. Guide the needle tip into the outer needle cap without touching the outer needle cap.
- L. When the needle is covered, carefully push the outer needle cap completely on. Then unscrew the needle. Dispose of it carefully and put the pen cap back on. When the pen is empty, carefully dispose of it without a needle attached. Please dispose of the pen and needle in accordance with local requirements.

- ⚠ Always remove the needle after each injection and store your Victoza[®] pen without a needle attached.
- ⚠ This prevents contamination or infection or leakage of liraglutide. It also ensures that the dosing is accurate.
- ⚠ Caregivers should be very careful when handling used needles to avoid hurting themselves with the needles.

Caring for your Victoza[®] pen

Your Victoza[®] pen is accurate and safe to use. But you must take care of it:

- Do not try to repair your pen or pull it apart.
- Keep your pen away from dust, dirt and all kinds of liquids.
- Clean the pen with a cloth moistened with a mild detergent. Do not try to wash it, soak it or lubricate it – this can harm the pen.

⚠ Important information

- Do not share your Victoza[®] pen with anyone else.
Keep your Victoza[®] pen out of reach of others, especially children.

HIGHLIGHTS OF PRESCRIBING INFORMATION

These highlights do not include all the information needed to use VICTOZA safely and effectively. See full prescribing information for VICTOZA.

VICTOZA® (liraglutide) injection, for subcutaneous use
Initial U.S. Approval: 2010

WARNING: RISK OF THYROID C-CELL TUMORS

See full prescribing information for complete boxed warning.

- Liraglutide causes thyroid C-cell tumors at clinically relevant exposures in both genders of rats and mice. It is unknown whether VICTOZA causes thyroid C-cell tumors, including medullary thyroid carcinoma (MTC), in humans, as the human relevance of liraglutide-induced rodent thyroid C-cell tumors has not been determined (5.1, 13.1).
- VICTOZA is contraindicated in patients with a personal or family history of MTC or in patients with Multiple Endocrine Neoplasia syndrome type 2 (MEN 2). Counsel patients regarding the potential risk of MTC and the symptoms of thyroid tumors (4, 5.1).

INDICATIONS AND USAGE

VICTOZA is a glucagon-like peptide-1 (GLP-1) receptor agonist indicated:

- as an adjunct to diet and exercise to improve glycemic control in patients 10 years and older with type 2 diabetes mellitus (1).
- to reduce the risk of major adverse cardiovascular events in adults with type 2 diabetes mellitus and established cardiovascular disease (1).

Limitations of Use:

- Not for treatment of type 1 diabetes mellitus or diabetic ketoacidosis.
- Has not been studied in combination with prandial insulin.

DOSAGE AND ADMINISTRATION

- Inspect visually prior to each injection. Only use if solution is clear, colorless, and contains no particles (2.1).
- Inject VICTOZA subcutaneously once-daily at any time of day, independently of meals, in the abdomen, thigh or upper arm (2.1).
- When using VICTOZA with insulin, administer as separate injections. Never mix. (2.1).
- Adult Dosage: Initiate at 0.6 mg daily for one week then increase to 1.2 mg daily. If additional glycemic control is required, increase the dose to 1.8 mg daily after one week of treatment with the 1.2 mg daily dose (2.2).
- Pediatric Dosage: Initiate at 0.6 mg daily for at least one week. If additional glycemic control is required increase the dose to 1.2 mg daily and if additional glycemic control is still required, increase the dose to 1.8 mg daily after at least one week of treatment with the 1.2 mg daily dose (2.3).

DOSAGE FORMS AND STRENGTHS

Injection: 6 mg/mL solution in a pre-filled, single-patient-use pen that delivers doses of 0.6 mg, 1.2 mg, or 1.8 mg (3).

CONTRAINDICATIONS

VICTOZA is contraindicated in patients with a personal or family history of medullary thyroid carcinoma or in patients with Multiple Endocrine Neoplasia syndrome type 2 (4).

VICTOZA is contraindicated in patients with a prior serious hypersensitivity reaction to VICTOZA or any of the product components (4).

WARNINGS AND PRECAUTIONS

- **Thyroid C-cell Tumors:** See Boxed Warning (5.1).
- **Pancreatitis:** Postmarketing reports, including fatal and non-fatal hemorrhagic or necrotizing pancreatitis. Discontinue promptly if pancreatitis is suspected. Do not restart if pancreatitis is confirmed (5.2).
- **Never share a VICTOZA pen** between patients, even if the needle is changed (5.3).
- **Serious Hypoglycemia:** When VICTOZA is used with an insulin secretagogue (e.g., a sulfonylurea) or insulin, consider lowering the dose of the insulin secretagogue or insulin to reduce the risk of hypoglycemia. The risk of hypoglycemia is higher in pediatric patients 10 years and older regardless of concomitant antidiabetic therapies (5.4).
- **Renal Impairment:** Postmarketing, usually in association with nausea, vomiting, diarrhea, or dehydration which may sometimes require hemodialysis. Use caution when initiating or escalating doses of VICTOZA in patients with renal impairment (5.5).
- **Hypersensitivity:** Postmarketing reports of serious hypersensitivity reactions (e.g., anaphylactic reactions and angioedema). Discontinue VICTOZA and promptly seek medical advice (5.6).
- **Acute Gallbladder Disease:** If cholelithiasis or cholecystitis are suspected, gallbladder studies are indicated (5.7).

ADVERSE REACTIONS

- The most common adverse reactions, reported in $\geq 5\%$ of patients treated with VICTOZA are: nausea, diarrhea, vomiting, decreased appetite, dyspepsia, constipation (6.1).
- Immunogenicity-related events, including urticaria, were more common among VICTOZA-treated patients (0.8%) than among comparator-treated patients (0.4%) in clinical trials (6.2).

To report SUSPECTED ADVERSE REACTIONS, contact Novo Nordisk Inc. at 1-877-484-2869 or FDA at 1-800-FDA-1088 or www.fda.gov/medwatch.

DRUG INTERACTIONS

Oral Medications: VICTOZA delays gastric emptying and may impact absorption of concomitantly administered oral medications (7).
Concomitant Use with an Insulin Secretagogue (e.g., Sulfonylurea) or with Insulin: when initiating, consider reducing the dose of concomitantly administered insulin secretagogues (such as sulfonylureas) or insulin to reduce the risk of hypoglycemia (7).

USE IN SPECIFIC POPULATIONS

- **Pregnancy:** VICTOZA should be used during pregnancy only if the potential benefit justifies the potential risk to the fetus (8.1).

See 17 for PATIENT COUNSELING INFORMATION and FDA-Approved Medication Guide.

Revised: 8/2020

FULL PRESCRIBING INFORMATION: CONTENTS***WARNING: RISK OF THYROID C-CELL TUMORS**

- 1 INDICATIONS AND USAGE**
- 2 DOSAGE AND ADMINISTRATION**
 - 2.1 Important Dosing and Administration Instructions
 - 2.2 Adult Dosage
 - 2.3 Pediatric Dosage
- 3 DOSAGE FORMS AND STRENGTHS**
- 4 CONTRAINDICATIONS**
- 5 WARNINGS AND PRECAUTIONS**
 - 5.1 Risk of Thyroid C-cell Tumors
 - 5.2 Pancreatitis
 - 5.3 Never Share a VICTOZA Pen Between Patients
 - 5.4 Use with Medications Known to Cause Hypoglycemia
 - 5.5 Renal Impairment
 - 5.6 Hypersensitivity Reactions
 - 5.7 Acute Gallbladder Disease
- 6 ADVERSE REACTIONS**
 - 6.1 Clinical Trials Experience
 - 6.2 Immunogenicity
 - 6.3 Post-Marketing Experience
- 7 DRUG INTERACTIONS**
 - 7.1 Oral Medications
 - 7.2 Concomitant Use with an Insulin Secretagogue (e.g., Sulfonylurea) or with Insulin
- 8 USE IN SPECIFIC POPULATIONS**
 - 8.1 Pregnancy
 - 8.2 Lactation
 - 8.4 Pediatric Use
 - 8.5 Geriatric Use
 - 8.6 Renal Impairment
 - 8.7 Hepatic Impairment
 - 8.8 Gastroparesis

- 10 OVERDOSAGE**
- 11 DESCRIPTION**
- 12 CLINICAL PHARMACOLOGY**
 - 12.1 Mechanism of Action
 - 12.2 Pharmacodynamics
 - 12.3 Pharmacokinetics
- 13 NONCLINICAL TOXICOLOGY**
 - 13.1 Carcinogenesis, Mutagenesis, Impairment of Fertility
- 14 CLINICAL STUDIES**
 - 14.1 Glycemic Control Trials in Adults with Type 2 Diabetes Mellitus
 - 14.2 Glycemic Control Trial in Pediatric Patients 10 Years of Age and Older with Type 2 Diabetes Mellitus
 - 14.3 Cardiovascular Outcomes Trial in Patients with Type 2 Diabetes Mellitus and Atherosclerotic Cardiovascular Disease
- 16 HOW SUPPLIED/STORAGE AND HANDLING**
 - 16.1 How Supplied
 - 16.2 Recommended Storage
- 17 PATIENT COUNSELING INFORMATION**

*Sections or subsections omitted from the full prescribing information are not listed.

FULL PRESCRIBING INFORMATION

WARNING: RISK OF THYROID C-CELL TUMORS

- **Liraglutide causes dose-dependent and treatment-duration-dependent thyroid C-cell tumors at clinically relevant exposures in both genders of rats and mice. It is unknown whether VICTOZA causes thyroid C-cell tumors, including medullary thyroid carcinoma (MTC), in humans, as the human relevance of liraglutide-induced rodent thyroid C-cell tumors has not been determined [see Warnings and Precautions (5.1) and Nonclinical Toxicology (13.1)].**
- **VICTOZA is contraindicated in patients with a personal or family history of MTC and in patients with Multiple Endocrine Neoplasia syndrome type 2 (MEN 2). Counsel patients regarding the potential risk for MTC with the use of VICTOZA and inform them of symptoms of thyroid tumors (e.g., a mass in the neck, dysphagia, dyspnea, persistent hoarseness). Routine monitoring of serum calcitonin or using thyroid ultrasound is of uncertain value for early detection of MTC in patients treated with VICTOZA [see Contraindications (4) and Warnings and Precautions (5.1)].**

1 INDICATIONS AND USAGE

VICTOZA is indicated:

- as an adjunct to diet and exercise to improve glycemic control in patients 10 years and older with type 2 diabetes mellitus,
- to reduce the risk of major adverse cardiovascular events (cardiovascular death, non-fatal myocardial infarction, or non-fatal stroke) in adults with type 2 diabetes mellitus and established cardiovascular disease [see Clinical Studies (14.3)].

Limitations of Use:

- VICTOZA should not be used in patients with type 1 diabetes mellitus or for the treatment of diabetic ketoacidosis, as it would not be effective in these settings.
- The concurrent use of VICTOZA and prandial insulin has not been studied.

2 DOSAGE AND ADMINISTRATION

2.1 Important Dosing and Administration Instructions

- Inspect visually prior to each injection. Only use if solution is clear, colorless, and contains no particles.
- Inject VICTOZA subcutaneously once-daily at any time of day, independently of meals.
- Inject VICTOZA subcutaneously in the abdomen, thigh or upper arm. No dose adjustment is needed if changing the injection site and/or timing.
- When using VICTOZA with insulin, administer as separate injections. Never mix.
- It is acceptable to inject VICTOZA and insulin in the same body region but the injections should not be adjacent to each other.
- If a dose is missed, resume the once-daily regimen as prescribed with the next scheduled dose. Do not administer an extra dose or increase the dose to make up for the missed dose.
- If more than 3 days have elapsed since the last VICTOZA dose, reinitiate VICTOZA at 0.6 mg to mitigate any gastrointestinal symptoms associated with reinitiation of treatment. Upon reinitiation, VICTOZA should be titrated at the discretion of the prescriber.

2.2 Adult Dosage

- Initiate VICTOZA with a dose of 0.6 mg daily for one week. The 0.6 mg dose is a starting dose intended to reduce gastrointestinal symptoms during initial titration, and is not effective for glycemic control in adults. After one week at 0.6 mg per day, increase the dose to 1.2 mg daily.

- If additional glycemic control is required, increase the dose to 1.8 mg daily after at least one week of treatment with the 1.2 mg daily dose.

2.3 Pediatric Dosage

- Initiate VICTOZA with a dose of 0.6 mg daily.
- After at least one week at 0.6 mg daily, the dose may be increased to 1.2 mg daily if additional glycemic control is required.
- If additional glycemic control is required, increase the dose to 1.8 mg daily after at least one week of treatment with the 1.2 mg daily dose.

3 DOSAGE FORMS AND STRENGTHS

Injection: 18 mg/3 mL (6 mg/mL) clear, colorless solution in a pre-filled, single-patient-use pen that delivers doses of 0.6 mg, 1.2 mg, or 1.8 mg.

4 CONTRAINDICATIONS

• Medullary Thyroid Carcinoma

VICTOZA is contraindicated in patients with a personal or family history of medullary thyroid carcinoma (MTC) or in patients with Multiple Endocrine Neoplasia syndrome type 2 (MEN 2).

• Hypersensitivity

VICTOZA is contraindicated in patients with a prior serious hypersensitivity reaction to VICTOZA or to any of the product components. Serious hypersensitivity reactions including anaphylactic reactions and angioedema have been reported with VICTOZA [see *Warnings and Precautions* (5.6)].

5 WARNINGS AND PRECAUTIONS

5.1 Risk of Thyroid C-cell Tumors

Liraglutide causes dose-dependent and treatment-duration-dependent thyroid C-cell tumors (adenomas and/or carcinomas) at clinically relevant exposures in both genders of rats and mice [see *Nonclinical Toxicology* (13.1)]. Malignant thyroid C-cell carcinomas were detected in rats and mice. It is unknown whether VICTOZA will cause thyroid C-cell tumors, including medullary thyroid carcinoma (MTC), in humans, as the human relevance of liraglutide-induced rodent thyroid C-cell tumors has not been determined.

Cases of MTC in patients treated with VICTOZA have been reported in the postmarketing period; the data in these reports are insufficient to establish or exclude a causal relationship between MTC and VICTOZA use in humans.

VICTOZA is contraindicated in patients with a personal or family history of MTC or in patients with MEN 2. Counsel patients regarding the potential risk for MTC with the use of VICTOZA and inform them of symptoms of thyroid tumors (e.g., a mass in the neck, dysphagia, dyspnea, persistent hoarseness). Routine monitoring of serum calcitonin or using thyroid ultrasound is of uncertain value for early detection of MTC in patients treated with VICTOZA. Such monitoring may increase the risk of unnecessary procedures, due to low test specificity for serum calcitonin and a high background incidence of thyroid disease. Significantly elevated serum calcitonin may indicate MTC and patients with MTC usually have calcitonin values >50 ng/L. If serum calcitonin is measured and found to be elevated, the patient should be further evaluated. Patients with thyroid nodules noted on physical examination or neck imaging should also be further evaluated.

5.2 Pancreatitis

Based on spontaneous postmarketing reports, acute pancreatitis, including fatal and non-fatal hemorrhagic or necrotizing pancreatitis, has been observed in patients treated with VICTOZA. After initiation of VICTOZA, observe patients carefully for signs and symptoms of pancreatitis (including persistent severe abdominal pain,

sometimes radiating to the back and which may or may not be accompanied by vomiting). If pancreatitis is suspected, VICTOZA should promptly be discontinued and appropriate management should be initiated. If pancreatitis is confirmed, VICTOZA should not be restarted.

In glycemic control trials of VICTOZA, there have been 13 cases of pancreatitis among VICTOZA-treated patients and 1 case in a comparator (glimepiride) treated patient (2.7 vs. 0.5 cases per 1000 patient-years). Nine of the 13 cases with VICTOZA were reported as acute pancreatitis and four were reported as chronic pancreatitis. In one case in a VICTOZA-treated patient, pancreatitis, with necrosis, was observed and led to death; however clinical causality could not be established. Some patients had other risk factors for pancreatitis, such as a history of cholelithiasis or alcohol abuse.

VICTOZA has been studied in a limited number of patients with a history of pancreatitis. It is unknown if patients with a history of pancreatitis are at higher risk for development of pancreatitis on VICTOZA.

5.3 Never Share a VICTOZA Pen Between Patients

VICTOZA pens must never be shared between patients, even if the needle is changed. Pen-sharing poses a risk for transmission of blood-borne pathogens.

5.4 Use with Medications Known to Cause Hypoglycemia

Patients receiving VICTOZA in combination with an insulin secretagogue (e.g., sulfonylurea) or insulin may have an increased risk of hypoglycemia. The risk of hypoglycemia may be lowered by a reduction in the dose of sulfonylurea (or other concomitantly administered insulin secretagogues) or insulin [*see Adverse Reactions (6.1), Drug Interactions (7.2)*].

In pediatric patients 10 years of age and older, the risk of hypoglycemia was higher with VICTOZA regardless of concomitant antidiabetic therapies.

5.5 Renal Impairment

VICTOZA has not been found to be directly nephrotoxic in animal studies or clinical trials.

There have been postmarketing reports of acute renal failure and worsening of chronic renal failure, which may sometimes require hemodialysis in VICTOZA-treated patients [*see Adverse Reactions (6.2)*]. Some of these events were reported in patients without known underlying renal disease. A majority of the reported events occurred in patients who had experienced nausea, vomiting, diarrhea, or dehydration [*see Adverse Reactions (6.1)*]. Some of the reported events occurred in patients receiving one or more medications known to affect renal function or hydration status. Altered renal function has been reversed in many of the reported cases with supportive treatment and discontinuation of potentially causative agents, including VICTOZA. Use caution when initiating or escalating doses of VICTOZA in patients with renal impairment [*see Use in Specific Populations (8.6)*].

5.6 Hypersensitivity Reactions

There have been postmarketing reports of serious hypersensitivity reactions (e.g., anaphylactic reactions and angioedema) in patients treated with VICTOZA. If a hypersensitivity reaction occurs, discontinue VICTOZA; treat promptly per standard of care, and monitor until signs and symptoms resolve. Do not use in patients with a previous hypersensitivity reaction to VICTOZA [*see Contraindications (4)*].

Anaphylaxis and angioedema have been reported with other GLP-1 receptor agonists. Use caution in a patient with a history of anaphylaxis or angioedema with another GLP-receptor agonist because it is unknown whether such patients will be predisposed to these reactions with VICTOZA.

5.7 Acute Gallbladder Disease

In the LEADER trial [see *Clinical Studies (14.3)*], 3.1% of VICTOZA-treated patients versus 1.9% of placebo-treated patients reported an acute event of gallbladder disease, such as cholelithiasis or cholecystitis. The majority of events required hospitalization or cholecystectomy. If cholelithiasis is suspected, gallbladder studies and appropriate clinical follow-up are indicated.

6 ADVERSE REACTIONS

The following serious adverse reactions are described below or elsewhere in the prescribing information:

- Risk of Thyroid C-cell Tumors [see *Warnings and Precautions (5.1)*]
- Pancreatitis [see *Warnings and Precautions (5.2)*]
- Use with Medications Known to Cause Hypoglycemia [see *Warnings and Precautions (5.4)*]
- Renal Impairment [see *Warnings and Precautions (5.5)*]
- Hypersensitivity Reactions [see *Warnings and Precautions (5.6)*]

6.1 Clinical Trials Experience

Because clinical trials are conducted under widely varying conditions, adverse reaction rates observed in the clinical trials of a drug cannot be directly compared to rates in the clinical trials of another drug and may not reflect the rates observed in practice.

Common Adverse Reactions

The safety of VICTOZA in subjects with type 2 diabetes was evaluated in 5 glycemic control, placebo-controlled trials in adults and one trial of 52 weeks duration in pediatric patients 10 years of age and older [see *Clinical Studies (14.1)*]. The data in Table 1 reflect exposure of 1673 adult patients to VICTOZA and a mean duration of exposure to VICTOZA of 37.3 weeks. The mean age of adult patients was 58 years, 4% were 75 years or older and 54% were male. The population was 79% White, 6% Black or African American, 13% Asian; 4% were of Hispanic or Latino ethnicity. At baseline the population had diabetes for an average of 9.1 years and a mean HbA_{1c} of 8.4%. Baseline estimated renal function was normal or mildly impaired in 88.1% and moderately impaired in 11.9% of the pooled population.

Table 1 shows common adverse reactions in adults, excluding hypoglycemia, associated with the use of VICTOZA. These adverse reactions occurred more commonly on VICTOZA than on placebo and occurred in at least 5% of patients treated with VICTOZA. Overall, the type, and severity of adverse reactions in adolescents and children aged 10 years and above were comparable to that observed in the adult population.

Table 1 Adverse reactions reported in ≥ 5% of VICTOZA-treated patients

	Placebo N=661	Liraglutide 1.2 mg N= 645	Liraglutide 1.8 mg N= 1024
Adverse Reaction	(%)	(%)	(%)
Nausea	5	18	20
Diarrhea	4	10	12
Headache	7	11	10
Nasopharyngitis	8	9	10
Vomiting	2	6	9
Decreased appetite	1	10	9
Dyspepsia	1	4	7
Upper Respiratory Tract Infection	6	7	6
Constipation	1	5	5
Back Pain	3	4	5

Cumulative proportions were calculated combining studies using Cochran-Mantel-Haenszel weights.

In an analysis of placebo- and active-controlled trials, the types and frequency of common adverse reactions, excluding hypoglycemia, were similar to those listed in Table 1.

Other Adverse Reactions

Gastrointestinal Adverse Reactions

In the pool of 5 glycemic control, placebo-controlled clinical trials, withdrawals due to gastrointestinal adverse reactions, occurred in 4.3% of VICTOZA-treated patients and 0.5% of placebo-treated patients. Withdrawal due to gastrointestinal adverse events mainly occurred during the first 2-3 months of the trials.

Injection site reactions

Injection site reactions (e.g., injection site rash, erythema) were reported in approximately 2% of VICTOZA-treated patients in the five double-blind, glycemic control trials of at least 26 weeks duration. Less than 0.2% of VICTOZA-treated patients discontinued due to injection site reactions.

Hypoglycemia

In 5 adult glycemic control, placebo-controlled clinical trials of at least 26 weeks duration, hypoglycemia requiring the assistance of another person for treatment occurred in 8 VICTOZA-treated patients (7.5 events per 1000 patient-years). Of these 8 VICTOZA-treated patients, 7 patients were concomitantly using a sulfonylurea.

Table 2 Adult Incidence (%) and Rate (episodes/patient year) of Hypoglycemia in 26-Week Combination Therapy Placebo- controlled Trials

	Placebo Comparator	VICTOZA Treatment
Add-on to Metformin	Placebo + Metformin (N = 121)	VICTOZA + Metformin (N = 724)
Patient not able to self-treat	0	0.1 (0.001)
Patient able to self-treat	2.5 (0.06)	3.6 (0.05)
Add-on to Glimepiride	Placebo + Glimepiride (N = 114)	VICTOZA + Glimepiride (N = 695)
Patient not able to self-treat	0	0.1 (0.003)
Patient able to self-treat	2.6 (0.17)	7.5 (0.38)
Not classified	0	0.9 (0.05)
Add-on to Metformin + Rosiglitazone	Placebo + Metformin + Rosiglitazone (N = 175)	VICTOZA + Metformin + Rosiglitazone (N = 355)
Patient not able to self-treat	0	0
Patient able to self-treat	4.6 (0.15)	7.9 (0.49)
Not classified	1.1 (0.03)	0.6 (0.01)
Add-on to Metformin + Glimepiride	Placebo + Metformin + Glimepiride (N = 114)	VICTOZA + Metformin + Glimepiride (N = 230)
Patient not able to self-treat	0	2.2 (0.06)
Patient able to self-treat	16.7 (0.95)	27.4 (1.16)
Not classified	0	0

“Patient not able to self-treat” is defined as an event requiring the assistance of another person for treatment.

In a 26-week pediatric placebo-controlled clinical trial with a 26-week open-label extension, 21.2% of VICTOZA treated patients (mean age 14.6 years) with type 2 diabetes, had hypoglycemia with a blood glucose <54 mg/dL with or without symptoms (335 events per 1000 patient years). No severe hypoglycemic episodes

occurred in the VICTOZA treatment group (severe hypoglycemia was defined as an episode requiring assistance of another person to actively administer carbohydrate, glucagon, or other resuscitative actions).

Papillary thyroid carcinoma

In glycemic control trials of VICTOZA, there were 7 reported cases of papillary thyroid carcinoma in patients treated with VICTOZA and 1 case in a comparator-treated patient (1.5 vs. 0.5 cases per 1000 patient-years). Most of these papillary thyroid carcinomas were <1 cm in greatest diameter and were diagnosed in surgical pathology specimens after thyroidectomy prompted by findings on protocol-specified screening with serum calcitonin or thyroid ultrasound.

Cholelithiasis and cholecystitis

In glycemic control trials of VICTOZA, the incidence of cholelithiasis was 0.3% in both VICTOZA-treated and placebo-treated patients. The incidence of cholecystitis was 0.2% in both VICTOZA-treated and placebo-treated patients.

In the LEADER trial [see *Clinical Studies (14.3)*], the incidence of cholelithiasis was 1.5% (3.9 cases per 1000 patient years of observation) in VICTOZA-treated and 1.1% (2.8 cases per 1000 patient years of observation) in placebo-treated patients, both on a background of standard of care. The incidence of acute cholecystitis was 1.1% (2.9 cases per 1000 patient years of observation) in VICTOZA-treated and 0.7% (1.9 cases per 1000 patient years of observation) in placebo-treated patients.

Laboratory Tests

Bilirubin

In the five glycemic control trials of at least 26 weeks duration, mildly elevated serum bilirubin concentrations (elevations to no more than twice the upper limit of the reference range) occurred in 4.0% of VICTOZA-treated patients, 2.1% of placebo-treated patients and 3.5% of active-comparator-treated patients. This finding was not accompanied by abnormalities in other liver tests. The significance of this isolated finding is unknown.

Calcitonin

Calcitonin, a biological marker of MTC, was measured throughout the clinical development program. At the end of the glycemic control trials, adjusted mean serum calcitonin concentrations were higher in VICTOZA-treated patients compared to placebo-treated patients but not compared to patients receiving active comparator. Between group differences in adjusted mean serum calcitonin values were approximately 0.1 ng/L or less. Among patients with pretreatment calcitonin <20 ng/L, calcitonin elevations to >20 ng/L occurred in 0.7% of VICTOZA-treated patients, 0.3% of placebo-treated patients, and 0.5% of active-comparator-treated patients. The clinical significance of these findings is unknown.

Lipase and Amylase

In one glycemic control trial in renal impairment patients, a mean increase of 33% for lipase and 15% for amylase from baseline was observed for VICTOZA-treated patients while placebo-treated patients had a mean decrease in lipase of 3% and a mean increase in amylase of 1%.

In the LEADER trial, serum lipase and amylase were routinely measured. Among VICTOZA-treated patients, 7.9% had a lipase value at any time during treatment of greater than or equal to 3 times the upper limit of normal compared with 4.5% of placebo-treated patients, and 1% of VICTOZA-treated patients had an amylase value at any time during treatment of greater than or equal to 3 times the upper limit of normal versus 0.7% of placebo-treated patients.

The clinical significance of elevations in lipase or amylase with VICTOZA is unknown in the absence of other signs and symptoms of pancreatitis [see *Warnings and Precautions (5.2)*].

Vital signs

VICTOZA did not have adverse effects on blood pressure. Mean increases from baseline in heart rate of 2 to 3 beats per minute have been observed with VICTOZA compared to placebo.

6.2 Immunogenicity

Consistent with the potentially immunogenic properties of protein and peptide pharmaceuticals, patients treated with VICTOZA may develop anti-liraglutide antibodies. The detection of antibody formation is highly dependent on the sensitivity and specificity of the assay. Additionally, the observed incidence of antibody (including neutralizing antibody) positivity in an assay may be influenced by several factors including assay methodology, sample handling, timing of sample collection, concomitant medications, and underlying disease. For these reasons, the incidence of antibodies to liraglutide cannot be directly compared with the incidence of antibodies of other products.

Approximately 50-70% of VICTOZA-treated patients in five double-blind clinical trials of 26 weeks duration or longer were tested for the presence of anti-liraglutide antibodies at the end of treatment. Low titers (concentrations not requiring dilution of serum) of anti-liraglutide antibodies were detected in 8.6% of these VICTOZA-treated patients. Cross-reacting anti-liraglutide antibodies to native glucagon-like peptide-1 (GLP-1) occurred in 6.9% of the VICTOZA-treated patients in the double-blind 52-week monotherapy trial and in 4.8% of the VICTOZA-treated patients in the double-blind 26-week add-on combination therapy trials. These cross-reacting antibodies were not tested for neutralizing effect against native GLP-1, and thus the potential for clinically significant neutralization of native GLP-1 was not assessed. Antibodies that had a neutralizing effect on liraglutide in an *in vitro* assay occurred in 2.3% of the VICTOZA-treated patients in the double-blind 52-week monotherapy trial and in 1.0% of the VICTOZA-treated patients in the double-blind 26-week add-on combination therapy trials.

Antibody formation was not associated with reduced efficacy of VICTOZA when comparing mean HbA_{1c} of all antibody-positive and all antibody-negative patients. However, the 3 patients with the highest titers of anti-liraglutide antibodies had no reduction in HbA_{1c} with VICTOZA treatment.

In five double-blind glycemic control trials of VICTOZA, events from a composite of adverse events potentially related to immunogenicity (e.g., urticaria, angioedema) occurred among 0.8% of VICTOZA-treated patients and among 0.4% of comparator-treated patients. Urticaria accounted for approximately one-half of the events in this composite for VICTOZA-treated patients. Patients who developed anti-liraglutide antibodies were not more likely to develop events from the immunogenicity events composite than were patients who did not develop anti-liraglutide antibodies.

In the LEADER trial [*see Clinical Studies (14.3)*], anti-liraglutide antibodies were detected in 11 out of the 1247 (0.9%) VICTOZA-treated patients with antibody measurements.

Of the 11 VICTOZA-treated patients who developed anti-liraglutide antibodies, none were observed to develop neutralizing antibodies to liraglutide, and 5 patients (0.4%) developed cross-reacting antibodies against native GLP-1.

In a clinical trial with pediatric patients 10 to 17 years [*see Clinical Studies (14.2)*], anti-liraglutide antibodies were detected in 1 (1.5%) VICTOZA treated patient at week 26 and 5 (8.5%) VICTOZA treated patients at week 53. None of the 5 had antibodies cross reactive to native GLP-1 or had neutralizing antibodies.

6.3 Post-Marketing Experience

The following additional adverse reactions have been reported during post-approval use of VICTOZA. Because these events are reported voluntarily from a population of uncertain size, it is generally not possible to reliably estimate their frequency or establish a causal relationship to drug exposure.

- Medullary thyroid carcinoma
- Dehydration resulting from nausea, vomiting and diarrhea.
- Increased serum creatinine, acute renal failure or worsening of chronic renal failure, sometimes requiring hemodialysis.
- Angioedema and anaphylactic reactions.
- Allergic reactions: rash and pruritus
- Acute pancreatitis, hemorrhagic and necrotizing pancreatitis sometimes resulting in death
- Hepatobiliary disorders: elevations of liver enzymes, hepatitis

7 DRUG INTERACTIONS

7.1 Oral Medications

VICTOZA causes a delay of gastric emptying, and thereby has the potential to impact the absorption of concomitantly administered oral medications. In clinical pharmacology trials, VICTOZA did not affect the absorption of the tested orally administered medications to any clinically relevant degree. Nonetheless, caution should be exercised when oral medications are concomitantly administered with VICTOZA.

7.2 Concomitant Use with an Insulin Secretagogue (e.g., Sulfonylurea) or with Insulin

When initiating VICTOZA, consider reducing the dose of concomitantly administered insulin secretagogues (such as sulfonylureas) or insulin to reduce the risk of hypoglycemia [*see Warnings and Precautions (5.4) and Adverse Reactions (6)*].

8 USE IN SPECIFIC POPULATIONS

8.1 Pregnancy

Risk Summary

Based on animal reproduction studies, there may be risks to the fetus from exposure to VICTOZA during pregnancy. VICTOZA should be used during pregnancy only if the potential benefit justifies the potential risk to the fetus.

Animal reproduction studies identified increased adverse developmental outcomes from exposure during pregnancy. Liraglutide exposure was associated with early embryonic deaths and an imbalance in some fetal abnormalities in pregnant rats administered liraglutide during organogenesis at doses that approximate clinical exposures at the maximum recommended human dose (MRHD) of 1.8 mg/day. In pregnant rabbits administered liraglutide during organogenesis, decreased fetal weight and an increased incidence of major fetal abnormalities were seen at exposures below the human exposures at the MRHD [*see Animal Data*].

The estimated background risk of major birth defects for women with uncontrolled pre-gestational diabetes (Hemoglobin A_{1C} >7) is 6 to 10%. The major birth defect rate has been reported to be as high as 20 to 25% in women with a Hemoglobin A_{1C} >10. In the U.S. general population, the estimated background risk of major birth defects and miscarriage in clinically recognized pregnancies is 2-4% and 15-20%, respectively.

Clinical Considerations

Disease-associated maternal and/or embryo/fetal risk

Poorly controlled diabetes in pregnancy increases the maternal risk for diabetic ketoacidosis, pre-eclampsia, spontaneous abortions, preterm delivery, and delivery complications. Poorly controlled diabetes increases the fetal risk for major birth defects, still birth, and macrosomia related morbidity.

Animal Data

Female rats given subcutaneous doses of 0.1, 0.25 and 1.0 mg/kg/day liraglutide beginning 2 weeks before mating through gestation day 17 had estimated systemic exposures 0.8-, 3-, and 11-times the human exposure at the MRHD based on plasma AUC comparison. The number of early embryonic deaths in the 1 mg/kg/day group increased slightly. Fetal abnormalities and variations in kidneys and blood vessels, irregular ossification of the skull, and a more complete state of ossification occurred at all doses. Mottled liver and minimally kinked ribs occurred at the highest dose. The incidence of fetal malformations in liraglutide-treated groups exceeding concurrent and historical controls were misshapen oropharynx and/or narrowed opening into larynx at 0.1 mg/kg/day and umbilical hernia at 0.1 and 0.25 mg/kg/day.

Pregnant rabbits given subcutaneous doses of 0.01, 0.025 and 0.05 mg/kg/day liraglutide from gestation day 6 through day 18 inclusive, had estimated systemic exposures less than the human exposure at the MRHD of 1.8 mg/day at all doses, based on plasma AUC. Liraglutide decreased fetal weight and dose-dependently increased the incidence of total major fetal abnormalities at all doses. The incidence of malformations exceeded concurrent and historical controls at 0.01 mg/kg/day (kidneys, scapula), ≥ 0.01 mg/kg/day (eyes, forelimb), 0.025 mg/kg/day (brain, tail and sacral vertebrae, major blood vessels and heart, umbilicus), ≥ 0.025 mg/kg/day (sternum) and at 0.05 mg/kg/day (parietal bones, major blood vessels). Irregular ossification and/or skeletal abnormalities occurred in the skull and jaw, vertebrae and ribs, sternum, pelvis, tail, and scapula; and dose-dependent minor skeletal variations were observed. Visceral abnormalities occurred in blood vessels, lung, liver, and esophagus. Bilobed or bifurcated gallbladder was seen in all treatment groups, but not in the control group.

In pregnant female rats given subcutaneous doses of 0.1, 0.25 and 1.0 mg/kg/day liraglutide from gestation day 6 through weaning or termination of nursing on lactation day 24, estimated systemic exposures were 0.8-, 3-, and 11-times human exposure at the MRHD of 1.8 mg/day, based on plasma AUC. A slight delay in parturition was observed in the majority of treated rats. Group mean body weight of neonatal rats from liraglutide-treated dams was lower than neonatal rats from control group dams. Bloody scabs and agitated behavior occurred in male rats descended from dams treated with 1 mg/kg/day liraglutide. Group mean body weight from birth to postpartum day 14 trended lower in F₂ generation rats descended from liraglutide-treated rats compared to F₂ generation rats descended from controls, but differences did not reach statistical significance for any group.

8.2 Lactation

Risk Summary

There are no data on the presence of VICTOZA in human milk, the effects on the breastfed infant, or the effects on milk production. Liraglutide was present in milk of lactating rats [*see Data*].

Developmental and health benefits of breastfeeding should be considered along with the mother's clinical need for VICTOZA and any potential adverse effects on the breastfed infant from VICTOZA or from the underlying maternal condition.

Data

In lactating rats, liraglutide was present unchanged in milk at concentrations approximately 50% of maternal plasma concentrations.

8.4 Pediatric Use

The safety and effectiveness of VICTOZA as an adjunct to diet and exercise to improve glycemic control in type 2 diabetes mellitus have been established in pediatric patients 10 years of age and older. Use of VICTOZA for this indication is supported by a 26-week placebo-controlled clinical trial and a 26-week open-label extension in 134 pediatric patients 10 to 17 years of age with type 2 diabetes, a pediatric pharmacokinetic study, and studies in adults with type 2 diabetes mellitus [*see Clinical Pharmacology (12.3) and Clinical Studies*

(14.1,14.2)]. The risk of hypoglycemia was higher with VICTOZA in pediatric patients regardless of concomitant antidiabetic therapies.

The safety and effectiveness of VICTOZA have not been established in pediatric patients less than 10 years of age.

8.5 Geriatric Use

In the VICTOZA treatment arms of the glycemic control trials, a total of 832 (19.3%) of the patients were 65 to 74 years of age and 145 (3.4%) were 75 years of age and over. No overall differences in safety or efficacy were observed between these patients and younger patients, but greater sensitivity of some older individuals cannot be ruled out.

In the VICTOZA treatment arm of the LEADER trial [see *Clinical Studies (14.3)*], a total of 1738 (37.2%) patients were 65 to 74 years of age, 401 (8.6%) were 75 to 84 years of age, and 17 (0.4%) were 85 years of age or older at baseline. No overall differences in safety or efficacy were observed between these patients and younger patients.

8.6 Renal Impairment

No dose adjustment of VICTOZA is recommended for patients with renal impairment [see *Clinical Pharmacology (12.3)*]. The safety and efficacy of VICTOZA was evaluated in a 26-week clinical study that included patients with moderate renal impairment (eGFR 30 to 60 mL/min/1.73m²) [see *Clinical Studies (14.1)*].

In the VICTOZA treatment arm of the LEADER trial [see *Clinical Studies (14.3)*], 1932 (41.4%) patients had mild renal impairment, 999 (21.4%) patients had moderate renal impairment and 117 (2.5%) patients had severe renal impairment at baseline. No overall differences in safety or efficacy were seen in these patients compared to patients with normal renal function.

There is limited experience with VICTOZA in patients with end stage renal disease. There have been postmarketing reports of acute renal failure and worsening of chronic renal failure, which may sometimes require hemodialysis [see *Warnings and Precautions (5.5)* and *Adverse Reactions (6.2)*]. Use caution in patients who experience dehydration.

8.7 Hepatic Impairment

There is limited experience in patients with mild, moderate or severe hepatic impairment. Therefore, VICTOZA should be used with caution in this patient population. No dose adjustment of VICTOZA is recommended for patients with hepatic impairment [see *Clinical Pharmacology (12.3)*].

8.8 Gastroparesis

VICTOZA slows gastric emptying. VICTOZA has not been studied in patients with pre-existing gastroparesis.

10 OVERDOSAGE

Overdoses have been reported in clinical trials and post-marketing use of VICTOZA. Effects have included severe nausea and severe vomiting. In the event of overdose, appropriate supportive treatment should be initiated according to the patient's clinical signs and symptoms.

11 DESCRIPTION

VICTOZA contains liraglutide, an analog of human GLP-1 and acts as a GLP-1 receptor agonist. The peptide precursor of liraglutide, produced by a process that includes expression of recombinant DNA in *Saccharomyces cerevisiae*, has been engineered to be 97% homologous to native human GLP-1 by substituting arginine for

lysine at position 34. Liraglutide is made by attaching a C-16 fatty acid (palmitic acid) with a glutamic acid spacer on the remaining lysine residue at position 26 of the peptide precursor. The molecular formula of liraglutide is $C_{172}H_{265}N_{43}O_{51}$ and the molecular weight is 3751.2 Daltons. The structural formula (Figure 1) is:

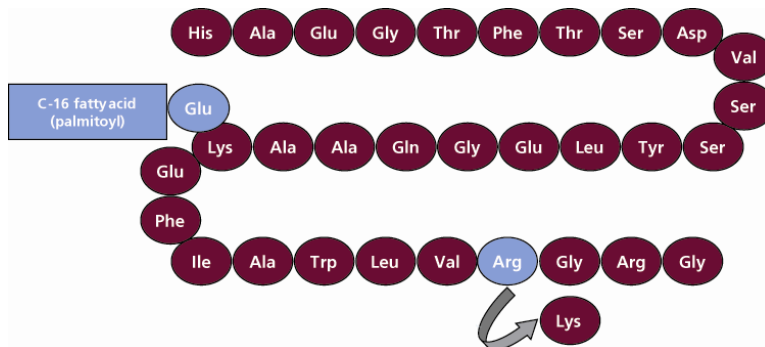

Figure 1 Structural Formula of liraglutide

VICTOZA is a sterile, aqueous, clear, colorless or almost colorless solution. Each 1 mL of VICTOZA solution contains 6 mg of liraglutide and the following inactive ingredients: disodium phosphate dihydrate, 1.42 mg; propylene glycol, 14 mg; phenol, 5.5 mg; and water for injection. VICTOZA has a pH of approximately 8.15, hydrochloric acid or sodium hydroxide may be added to adjust pH. Each pre-filled pen contains a 3 mL solution of VICTOZA equivalent to 18 mg liraglutide (free-base, anhydrous).

12 CLINICAL PHARMACOLOGY

12.1 Mechanism of Action

Liraglutide is an acylated human Glucagon-Like Peptide-1 (GLP-1) receptor agonist with 97% amino acid sequence homology to endogenous human GLP-1(7-37). GLP-1(7-37) represents <20% of total circulating endogenous GLP-1. Like GLP-1(7-37), liraglutide activates the GLP-1 receptor, a membrane-bound cell-surface receptor coupled to adenylyl cyclase by the stimulatory G-protein, G_s, in pancreatic beta cells. Liraglutide increases intracellular cyclic AMP (cAMP) leading to insulin release in the presence of elevated glucose concentrations. This insulin secretion subsides as blood glucose concentrations decrease and approach euglycemia. Liraglutide also decreases glucagon secretion in a glucose-dependent manner. The mechanism of blood glucose lowering also involves a delay in gastric emptying.

GLP-1(7-37) has a half-life of 1.5-2 minutes due to degradation by the ubiquitous endogenous enzymes, dipeptidyl peptidase IV (DPP-IV) and neutral endopeptidases (NEP). Unlike native GLP-1, liraglutide is stable against metabolic degradation by both peptidases and has a plasma half-life of 13 hours after subcutaneous administration. The pharmacokinetic profile of liraglutide, which makes it suitable for once daily administration, is a result of self-association that delays absorption, plasma protein binding and stability against metabolic degradation by DPP-IV and NEP.

12.2 Pharmacodynamics

VICTOZA's pharmacodynamic profile is consistent with its pharmacokinetic profile observed after single subcutaneous administration as VICTOZA lowered fasting, premeal and postprandial glucose throughout the day [see *Clinical Pharmacology (12.3)*].

Fasting and postprandial glucose was measured before and up to 5 hours after a standardized meal after treatment to steady state with 0.6, 1.2 and 1.8 mg VICTOZA or placebo. Compared to placebo, the postprandial plasma glucose AUC_{0-300min} was 35% lower after VICTOZA 1.2 mg and 38% lower after VICTOZA 1.8 mg.

Glucose-dependent insulin secretion

The effect of a single dose of 7.5 mcg/kg (~ 0.7 mg) VICTOZA on insulin secretion rates (ISR) was investigated in 10 patients with type 2 diabetes during graded glucose infusion. In these patients, on average, the ISR response was increased in a glucose-dependent manner (Figure 2).

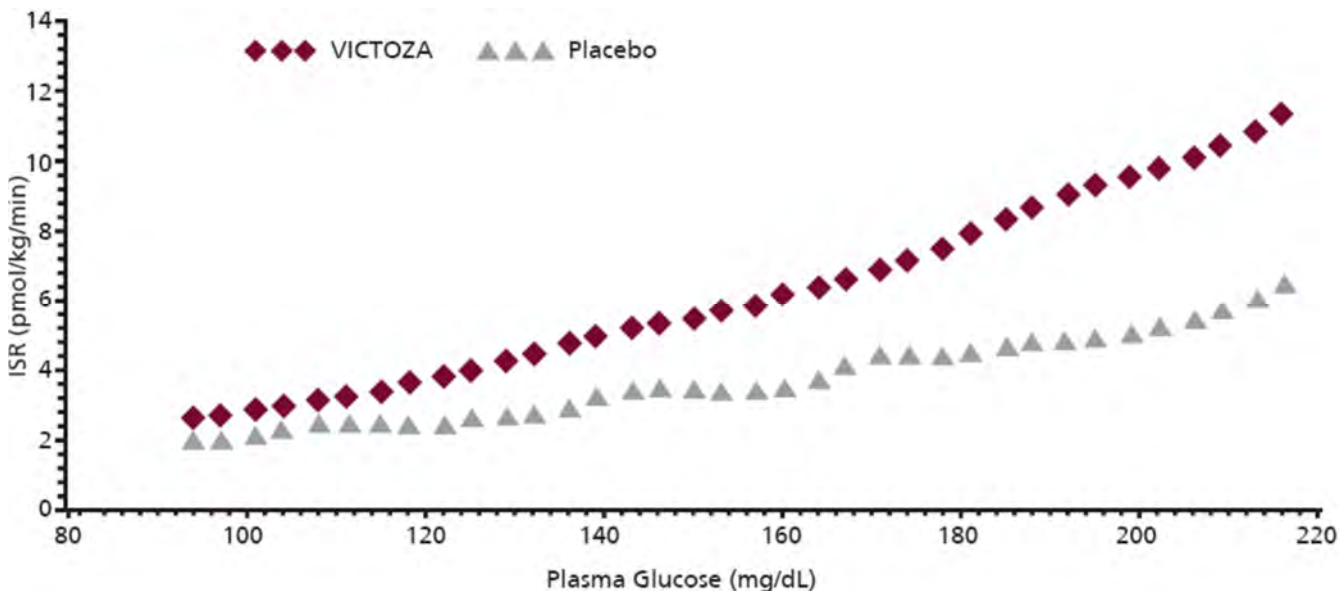

Figure

2 Mean Insulin Secretion Rate (ISR) versus Glucose Concentration Following Single-Dose VICTOZA 7.5 mcg/kg (~ 0.7 mg) or Placebo in Patients with Type 2 Diabetes (N=10) During Graded Glucose Infusion

Glucagon secretion

VICTOZA lowered blood glucose by stimulating insulin secretion and lowering glucagon secretion. A single dose of VICTOZA 7.5 mcg/kg (~ 0.7 mg) did not impair glucagon response to low glucose concentrations.

Gastric emptying

VICTOZA causes a delay of gastric emptying, thereby reducing the rate at which postprandial glucose appears in the circulation.

Cardiac Electrophysiology (QTc)

The effect of VICTOZA on cardiac repolarization was tested in a QTc study. VICTOZA at steady state concentrations with daily doses up to 1.8 mg did not produce QTc prolongation.

12.3 Pharmacokinetics

Absorption - Following subcutaneous administration, maximum concentrations of liraglutide are achieved at 8-12 hours post dosing. The mean peak (C_{max}) and total (AUC) exposures of liraglutide were 35 ng/mL and 960 ng·h/mL, respectively, for a subcutaneous single dose of 0.6 mg. After subcutaneous single dose administrations, C_{max} and AUC of liraglutide increased proportionally over the therapeutic dose range of 0.6 mg to 1.8 mg. At 1.8 mg VICTOZA, the average steady state concentration of liraglutide over 24 hours was approximately 128 ng/mL. $AUC_{0-\infty}$ was equivalent between upper arm and abdomen, and between upper arm and thigh. $AUC_{0-\infty}$ from thigh was 22% lower than that from abdomen. However, liraglutide exposures were considered comparable among these three subcutaneous injection sites. Absolute bioavailability of liraglutide following subcutaneous administration is approximately 55%.

Distribution - The mean apparent volume of distribution after subcutaneous administration of VICTOZA 0.6 mg is approximately 13 L. The mean volume of distribution after intravenous administration of VICTOZA is 0.07 L/kg. Liraglutide is extensively bound to plasma protein (>98%).

Metabolism - During the initial 24 hours following administration of a single [³H]-liraglutide dose to healthy subjects, the major component in plasma was intact liraglutide. Liraglutide is endogenously metabolized in a similar manner to large proteins without a specific organ as a major route of elimination.

Elimination - Following a [³H]-liraglutide dose, intact liraglutide was not detected in urine or feces. Only a minor part of the administered radioactivity was excreted as liraglutide-related metabolites in urine or feces (6% and 5%, respectively). The majority of urine and feces radioactivity was excreted during the first 6-8 days. The mean apparent clearance following subcutaneous administration of a single dose of liraglutide is approximately 1.2 L/h with an elimination half-life of approximately 13 hours, making VICTOZA suitable for once daily administration.

Specific Populations

Elderly - Age had no effect on the pharmacokinetics of VICTOZA based on a pharmacokinetic study in healthy elderly subjects (65 to 83 years) and population pharmacokinetic analyses of patients 18 to 80 years of age [*see Use in Specific Populations (8.5)*].

Gender - Based on the results of population pharmacokinetic analyses, females have 25% lower weight-adjusted clearance of VICTOZA compared to males. Based on the exposure response data, no dose adjustment is necessary based on gender.

Race and Ethnicity - Race and ethnicity had no effect on the pharmacokinetics of VICTOZA based on the results of population pharmacokinetic analyses that included Caucasian, Black, Asian and Hispanic/Non-Hispanic subjects.

Body Weight - Body weight significantly affects the pharmacokinetics of VICTOZA based on results of population pharmacokinetic analyses. The exposure of liraglutide decreases with an increase in baseline body weight. However, the 1.2 mg and 1.8 mg daily doses of VICTOZA provided adequate systemic exposures over the body weight range of 40 – 160 kg evaluated in the clinical trials. Liraglutide was not studied in patients with body weight >160 kg.

Pediatric - A population pharmacokinetic analysis was conducted for VICTOZA using data from 72 pediatric subjects (10 to 17 years of age) with type 2 diabetes. The pharmacokinetic profile of VICTOZA in the pediatric subjects was consistent with that in adults.

Renal Impairment - The single-dose pharmacokinetics of VICTOZA were evaluated in subjects with varying degrees of renal impairment. Subjects with mild (estimated creatinine clearance 50-80 mL/min) to severe (estimated creatinine clearance <30 mL/min) renal impairment and subjects with end-stage renal disease requiring dialysis were included in the trial. Compared to healthy subjects, liraglutide AUC in mild, moderate, and severe renal impairment and in end-stage renal disease was on average 35%, 19%, 29% and 30% lower, respectively [*see Use in Specific Populations (8.6)*].

Hepatic Impairment - The single-dose pharmacokinetics of VICTOZA were evaluated in subjects with varying degrees of hepatic impairment. Subjects with mild (Child Pugh score 5-6) to severe (Child Pugh score > 9) hepatic impairment were included in the trial. Compared to healthy subjects, liraglutide AUC in subjects with mild, moderate and severe hepatic impairment was on average 11%, 14% and 42% lower, respectively [*see Use in Specific Populations (8.7)*].

Drug Interactions

In vitro assessment of drug-drug interactions

VICTOZA has low potential for pharmacokinetic drug-drug interactions related to cytochrome P450 (CYP) and plasma protein binding.

In vivo assessment of drug-drug interactions

The drug-drug interaction studies were performed at steady state with VICTOZA 1.8 mg/day. Before administration of concomitant treatment, subjects underwent a 0.6 mg weekly dose increase to reach the maximum dose of 1.8 mg/day. Administration of the interacting drugs was timed so that C_{\max} of VICTOZA (8-12 h) would coincide with the absorption peak of the co-administered drugs.

Digoxin

A single dose of digoxin 1 mg was administered 7 hours after the dose of VICTOZA at steady state. The concomitant administration with VICTOZA resulted in a reduction of digoxin AUC by 16%; C_{\max} decreased by 31%. Digoxin median time to maximal concentration (T_{\max}) was delayed from 1 h to 1.5 h.

Lisinopril

A single dose of lisinopril 20 mg was administered 5 minutes after the dose of VICTOZA at steady state. The co-administration with VICTOZA resulted in a reduction of lisinopril AUC by 15%; C_{\max} decreased by 27%. Lisinopril median T_{\max} was delayed from 6 h to 8 h with VICTOZA.

Atorvastatin

VICTOZA did not change the overall exposure (AUC) of atorvastatin following a single dose of atorvastatin 40 mg, administered 5 hours after the dose of VICTOZA at steady state. Atorvastatin C_{\max} was decreased by 38% and median T_{\max} was delayed from 1 h to 3 h with VICTOZA.

Acetaminophen

VICTOZA did not change the overall exposure (AUC) of acetaminophen following a single dose of acetaminophen 1000 mg, administered 8 hours after the dose of VICTOZA at steady state. Acetaminophen C_{\max} was decreased by 31% and median T_{\max} was delayed up to 15 minutes.

Griseofulvin

VICTOZA did not change the overall exposure (AUC) of griseofulvin following co-administration of a single dose of griseofulvin 500 mg with VICTOZA at steady state. Griseofulvin C_{\max} increased by 37% while median T_{\max} did not change.

Oral Contraceptives

A single dose of an oral contraceptive combination product containing 0.03 mg ethinylestradiol and 0.15 mg levonorgestrel was administered under fed conditions and 7 hours after the dose of VICTOZA at steady state. VICTOZA lowered ethinylestradiol and levonorgestrel C_{\max} by 12% and 13%, respectively. There was no effect of VICTOZA on the overall exposure (AUC) of ethinylestradiol. VICTOZA increased the levonorgestrel $AUC_{0-\infty}$ by 18%. VICTOZA delayed T_{\max} for both ethinylestradiol and levonorgestrel by 1.5 h.

Insulin Detemir

No pharmacokinetic interaction was observed between VICTOZA and insulin detemir when separate subcutaneous injections of insulin detemir 0.5 Unit/kg (single-dose) and VICTOZA 1.8 mg (steady state) were administered in patients with type 2 diabetes.

13 NONCLINICAL TOXICOLOGY

13.1 Carcinogenesis, Mutagenesis, Impairment of Fertility

A 104-week carcinogenicity study was conducted in male and female CD-1 mice at doses of 0.03, 0.2, 1.0, and 3.0 mg/kg/day liraglutide administered by bolus subcutaneous injection yielding systemic exposures 0.2-, 2-,

10- and 45-times the human exposure, respectively, at the MRHD of 1.8 mg/day based on plasma AUC comparison. A dose-related increase in benign thyroid C-cell adenomas was seen in the 1.0 and the 3.0 mg/kg/day groups with incidences of 13% and 19% in males and 6% and 20% in females, respectively. C-cell adenomas did not occur in control groups or 0.03 and 0.2 mg/kg/day groups. Treatment-related malignant C-cell carcinomas occurred in 3% of females in the 3.0 mg/kg/day group. Thyroid C-cell tumors are rare findings during carcinogenicity testing in mice. A treatment-related increase in fibrosarcomas was seen on the dorsal skin and subcutis, the body surface used for drug injection, in males in the 3 mg/kg/day group. These fibrosarcomas were attributed to the high local concentration of drug near the injection site. The liraglutide concentration in the clinical formulation (6 mg/mL) is 10-times higher than the concentration in the formulation used to administer 3 mg/kg/day liraglutide to mice in the carcinogenicity study (0.6 mg/mL).

A 104-week carcinogenicity study was conducted in male and female Sprague Dawley rats at doses of 0.075, 0.25 and 0.75 mg/kg/day liraglutide administered by bolus subcutaneous injection with exposures 0.5-, 2- and 8-times the human exposure, respectively, resulting from the MRHD based on plasma AUC comparison. A treatment-related increase in benign thyroid C-cell adenomas was seen in males in 0.25 and 0.75 mg/kg/day liraglutide groups with incidences of 12%, 16%, 42%, and 46% and in all female liraglutide-treated groups with incidences of 10%, 27%, 33%, and 56% in 0 (control), 0.075, 0.25, and 0.75 mg/kg/day groups, respectively. A treatment-related increase in malignant thyroid C-cell carcinomas was observed in all male liraglutide-treated groups with incidences of 2%, 8%, 6%, and 14% and in females at 0.25 and 0.75 mg/kg/day with incidences of 0%, 0%, 4%, and 6% in 0 (control), 0.075, 0.25, and 0.75 mg/kg/day groups, respectively. Thyroid C-cell carcinomas are rare findings during carcinogenicity testing in rats.

Studies in mice demonstrated that liraglutide-induced C-cell proliferation was dependent on the GLP-1 receptor and that liraglutide did not cause activation of the REarranged during Transfection (RET) proto-oncogene in thyroid C-cells.

Human relevance of thyroid C-cell tumors in mice and rats is unknown and has not been determined by clinical studies or nonclinical studies [see *Boxed Warning and Warnings and Precautions (5.1)*].

Liraglutide was negative with and without metabolic activation in the Ames test for mutagenicity and in a human peripheral blood lymphocyte chromosome aberration test for clastogenicity. Liraglutide was negative in repeat-dose *in vivo* micronucleus tests in rats.

In rat fertility studies using subcutaneous doses of 0.1, 0.25 and 1.0 mg/kg/day liraglutide, males were treated for 4 weeks prior to and throughout mating and females were treated 2 weeks prior to and throughout mating until gestation day 17. No direct adverse effects on male fertility was observed at doses up to 1.0 mg/kg/day, a high dose yielding an estimated systemic exposure 11- times the human exposure at the MRHD, based on plasma AUC. In female rats, an increase in early embryonic deaths occurred at 1.0 mg/kg/day. Reduced body weight gain and food consumption were observed in females at the 1.0 mg/kg/day dose.

14 CLINICAL STUDIES

14.1 Glycemic Control Trials in Adults with Type 2 Diabetes Mellitus

In glycemic control trials, VICTOZA has been studied as monotherapy and in combination with one or two oral anti-diabetic medications or basal insulin. VICTOZA was also studied in a cardiovascular outcomes trial (LEADER trial).

In each of the placebo controlled trials, treatment with VICTOZA produced clinically and statistically significant improvements in hemoglobin A_{1c} and fasting plasma glucose (FPG) compared to placebo.

All VICTOZA-treated patients started at 0.6 mg/day. The dose was increased in weekly intervals by 0.6 mg to reach 1.2 mg or 1.8 mg for patients randomized to these higher doses. VICTOZA 0.6 mg is not effective for glycemic control and is intended only as a starting dose to reduce gastrointestinal intolerance [see Dosage and Administration (2)].

Monotherapy

In this 52-week trial, 746 patients were randomized to VICTOZA 1.2 mg, VICTOZA 1.8 mg, or glimepiride 8 mg. Patients who were randomized to glimepiride were initially treated with 2 mg daily for two weeks, increasing to 4 mg daily for another two weeks, and finally increasing to 8 mg daily. Treatment with VICTOZA 1.8 mg and 1.2 mg resulted in a statistically significant reduction in HbA_{1c} compared to glimepiride (Table 3). The percentage of patients who discontinued due to ineffective therapy was 3.6% in the VICTOZA 1.8 mg treatment group, 6.0% in the VICTOZA 1.2 mg treatment group, and 10.1% in the glimepiride-treatment group.

The mean age of participants was 53 years, and the mean duration of diabetes was 5 years. Participants were 49.7% male, 77.5% White, 12.6% Black or African American and 35.0% of Hispanic ethnicity. The mean BMI was 33.1 kg/m².

Table 3 Results of a 52-week monotherapy trial^a

	VICTOZA 1.8 mg	VICTOZA 1.2 mg	Glimepiride 8 mg
Intent-to-Treat Population (N)	246	251	248
HbA_{1c} (%) (Mean)			
Baseline	8.2	8.2	8.2
Change from baseline (adjusted mean) ^b	-1.1	-0.8	-0.5
Difference from glimepiride arm (adjusted mean) ^b	-0.6**	-0.3*	
95% Confidence Interval	(-0.8, -0.4)	(-0.5, -0.1)	
Percentage of patients achieving HbA _{1c} <7%	51	43	28
Fasting Plasma Glucose (mg/dL) (Mean)			
Baseline	172	168	172
Change from baseline (adjusted mean) ^b	-26	-15	-5
Difference from glimepiride arm (adjusted mean) ^b	-20**	-10*	
95% Confidence Interval	(-29, -12)	(-19, -1)	
Body Weight (kg) (Mean)			
Baseline	92.6	92.1	93.3
Change from baseline (adjusted mean) ^b	-2.5	-2.1	+1.1
Difference from glimepiride arm (adjusted mean) ^b	-3.6**	-3.2**	
95% Confidence Interval	(-4.3, -2.9)	(-3.9, -2.5)	

^aIntent-to-treat population using last observation on study

^bLeast squares mean adjusted for baseline value

*p-value <0.05

**p-value <0.0001

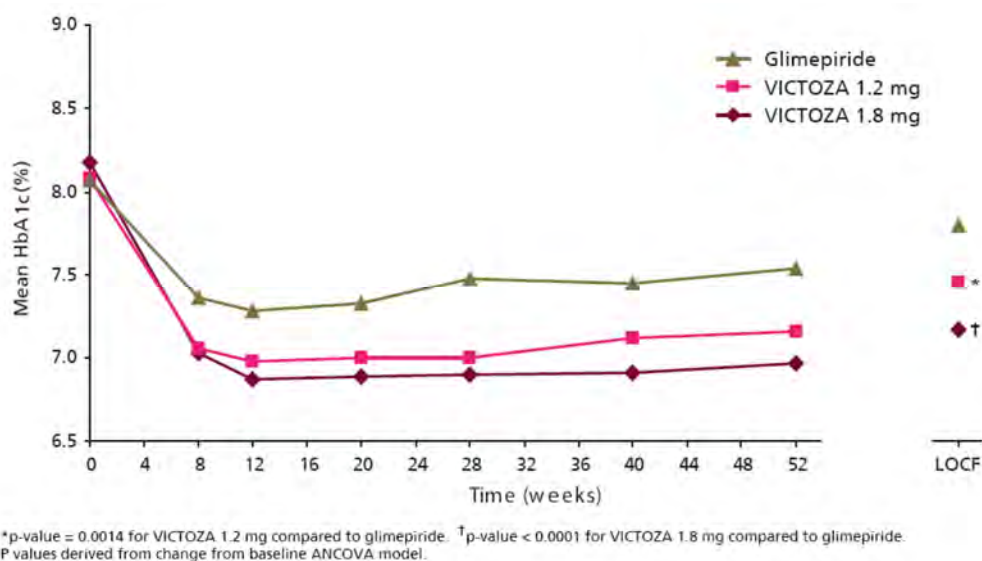

Figure 3 Mean HbA_{1c} for patients who completed the 52-week trial and for the Last Observation Carried Forward (LOCF, intent-to-treat) data at Week 52 (Monotherapy)

Combination Therapy

Add-on to Metformin

In this 26-week trial, 1091 patients were randomized to VICTOZA 0.6 mg, VICTOZA 1.2 mg, VICTOZA 1.8 mg, placebo, or glimepiride 4 mg (one-half of the maximal approved dose in the United States), all as add-on to metformin. Randomization occurred after a 6-week run-in period consisting of a 3-week initial forced metformin titration period followed by a maintenance period of another 3 weeks. During the titration period, doses of metformin were increased up to 2000 mg/day. Treatment with VICTOZA 1.2 mg and 1.8 mg as add-on to metformin resulted in a significant mean HbA_{1c} reduction relative to placebo add-on to metformin and resulted in a similar mean HbA_{1c} reduction relative to glimepiride 4 mg add-on to metformin (Table 4). The percentage of patients who discontinued due to ineffective therapy was 5.4% in the VICTOZA 1.8 mg + metformin treatment group, 3.3% in the VICTOZA 1.2 mg + metformin treatment group, 23.8% in the placebo + metformin treatment group, and 3.7% in the glimepiride + metformin treated group.

The mean age of participants was 57 years, and the mean duration of diabetes was 7 years. Participants were 58.2% male, 87.1% White and 2.4% Black or African American. The mean BMI was 31.0 kg/m².

Table 4 Results of a 26-week trial of VICTOZA as add-on to metformin^a

	VICTOZA 1.8 mg + Metformin	VICTOZA 1.2 mg + Metformin	Placebo + Metformin	Glimepiride 4 mg [†] + Metformin
Intent-to-Treat Population (N)	242	240	121	242
HbA_{1c} (%) (Mean)				
Baseline	8.4	8.3	8.4	8.4
Change from baseline (adjusted mean) ^b	-1.0	-1.0	+0.1	-1.0
Difference from placebo + metformin arm (adjusted mean) ^b	-1.1**	-1.1**		
95% Confidence Interval	(-1.3, -0.9)	(-1.3, -0.9)		
Difference from glimepiride + metformin arm (adjusted mean) ^b	0.0	0.0		
95% Confidence Interval	(-0.2, 0.2)	(-0.2, 0.2)		
Percentage of patients achieving HbA _{1c} <7%	42	35	11	36
Fasting Plasma Glucose (mg/dL) (Mean)				
Baseline	181	179	182	180
Change from baseline (adjusted mean) ^b	-30	-30	+7	-24

Difference from placebo + metformin arm (adjusted mean) ^b	-38**	-37**		
95% Confidence Interval	(-48, -27)	(-47, -26)		
Difference from glimepiride + metformin arm (adjusted mean) ^b	-7	-6		
95% Confidence Interval	(-16, 2)	(-15, 3)		
Body Weight (kg) (Mean)				
Baseline	88.0	88.5	91.0	89.0
Change from baseline (adjusted mean) ^b	-2.8	-2.6	-1.5	+1.0
Difference from placebo + metformin arm (adjusted mean) ^b	-1.3*	-1.1*		
95% Confidence Interval	(-2.2, -0.4)	(-2.0, -0.2)		
Difference from glimepiride + metformin arm (adjusted mean) ^b	-3.8**	-3.5**		
95% Confidence Interval	(-4.5, -3.0)	(-4.3, -2.8)		

^aIntent-to-treat population using last observation on study

^bLeast squares mean adjusted for baseline value

[†] For glimepiride, one-half of the maximal approved United States dose.

*p-value <0.05

**p-value <0.0001

VICTOZA Compared to Sitagliptin, Both as Add-on to Metformin

In this 26-week, open-label trial, 665 patients on a background of metformin \geq 1500 mg per day were randomized to VICTOZA 1.2 mg once-daily, VICTOZA 1.8 mg once-daily or sitagliptin 100 mg once-daily, all dosed according to approved labeling. Patients were to continue their current treatment on metformin at a stable, pre-trial dose level and dosing frequency.

The mean age of participants was 56 years, and the mean duration of diabetes was 6 years. Participants were 52.9% male, 86.6% White, 7.2% Black or African American and 16.2% of Hispanic ethnicity. The mean BMI was 32.8 kg/m².

The primary endpoint was the change in HbA_{1c} from baseline to Week 26. Treatment with VICTOZA 1.2 mg and VICTOZA 1.8 mg resulted in statistically significant reductions in HbA_{1c} relative to sitagliptin 100 mg (Table 5). The percentage of patients who discontinued due to ineffective therapy was 3.1% in the VICTOZA 1.2 mg group, 0.5% in the VICTOZA 1.8 mg treatment group, and 4.1% in the sitagliptin 100 mg treatment group. From a mean baseline body weight of 94 kg, there was a mean reduction of 2.7 kg for VICTOZA 1.2 mg, 3.3 kg for VICTOZA 1.8 mg, and 0.8 kg for sitagliptin 100 mg.

Table 5 Results of a 26-week open-label trial of VICTOZA Compared to Sitagliptin (both in combination with metformin)^a

	VICTOZA 1.8 mg + Metformin	VICTOZA 1.2 mg + Metformin	Sitagliptin 100 mg + Metformin
Intent-to-Treat Population (N)	218	221	219
HbA_{1c} (%) (Mean)			
Baseline	8.4	8.4	8.5
Change from baseline (adjusted mean)	-1.5	-1.2	-0.9
Difference from sitagliptin arm (adjusted mean) ^b	-0.6**	-0.3**	
95% Confidence Interval	(-0.8, -0.4)	(-0.5, -0.2)	
Percentage of patients achieving HbA _{1c} <7%	56	44	22
Fasting Plasma Glucose (mg/dL) (Mean)			
Baseline	179	182	180
Change from baseline (adjusted mean)	-39	-34	-15
Difference from sitagliptin arm (adjusted mean) ^b	-24**	-19**	
95% Confidence Interval	(-31, -16)	(-26, -12)	

^aIntent-to-treat population using last observation on study

^bLeast squares mean adjusted for baseline value

**p-value <0.0001

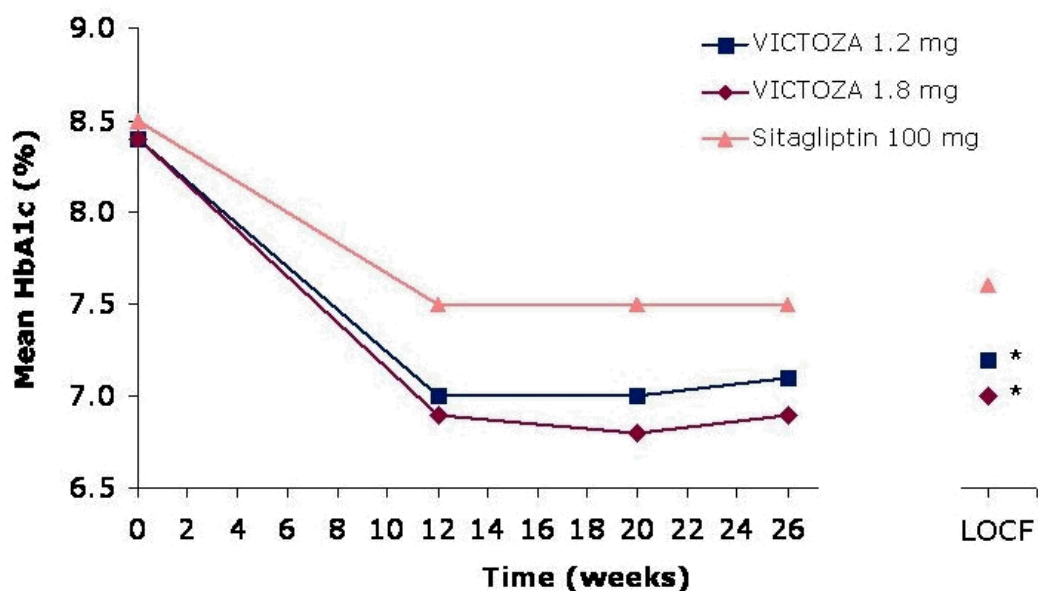

*p-value <0.0001 for Victoza compared with sitagliptin
P values derived from change from baseline ANCOVA model

Figure 4 Mean HbA_{1c} for patients who completed the 26-week trial and for the Last Observation Carried Forward (LOCF, intent-to-treat) data at Week 26

Combination Therapy with Metformin and Insulin

This 26-week open-label trial enrolled 988 patients with inadequate glycemic control (HbA_{1c} 7-10%) on metformin (≥ 1500 mg/day) alone or inadequate glycemic control (HbA_{1c} 7-8.5%) on metformin (≥ 1500 mg/day) and a sulfonylurea. Patients who were on metformin and a sulfonylurea discontinued the sulfonylurea then all patients entered a 12-week run-in period during which they received add-on therapy with VICTOZA titrated to 1.8 mg once-daily. At the end of the run-in period, 498 patients (50%) achieved HbA_{1c} <7% with VICTOZA 1.8 mg and metformin and continued treatment in a non-randomized, observational arm. Another 167 patients (17%) withdrew from the trial during the run-in period with approximately one-half of these patients doing so because of gastrointestinal adverse reactions [see Adverse Reactions (6.1)]. The remaining 323 patients with HbA_{1c} $\geq 7\%$ (33% of those who entered the run-in period) were randomized to 26 weeks of once-daily insulin detemir administered in the evening as add-on therapy (N=162) or to continued, unchanged treatment with VICTOZA 1.8 mg and metformin (N=161). The starting dose of insulin detemir was 10 units/day and the mean dose at the end of the 26-week randomized period was 39 units/day. During the 26 week randomized treatment period, the percentage of patients who discontinued due to ineffective therapy was 11.2% in the group randomized to continued treatment with VICTOZA 1.8 mg and metformin and 1.2% in the group randomized to add-on therapy with insulin detemir.

The mean age of participants was 57 years, and the mean duration of diabetes was 8 years. Participants were 55.7% male, 91.3% White, 5.6% Black or African American and 12.5% of Hispanic ethnicity. The mean BMI was 34.0 kg/m².

Treatment with insulin detemir as add-on to VICTOZA 1.8 mg + metformin resulted in statistically significant reductions in HbA_{1c} and FPG compared to continued, unchanged treatment with VICTOZA 1.8 mg + metformin alone (Table 6). From a mean baseline body weight of 96 kg after randomization, there was a mean reduction of 0.3 kg in the patients who received insulin detemir add-on therapy compared to a mean reduction of 1.1 kg in the patients who continued on unchanged treatment with VICTOZA 1.8 mg + metformin alone.

Table 6 Results of a 26-week open label trial of Insulin detemir as add on to VICTOZA + metformin compared to continued treatment with VICTOZA + metformin alone in patients not achieving HbA_{1c} < 7% after 12 weeks of Metformin and VICTOZA^a

	Insulin detemir + VICTOZA + Metformin	VICTOZA + Metformin
Intent-to-Treat Population (N)	162	157
HbA_{1c} (%) (Mean)		
Baseline (week 0)	7.6	7.6
Change from baseline (adjusted mean)	-0.5	0
Difference from VICTOZA + metformin arm (LS mean) ^b	-0.5**	
95% Confidence Interval	(-0.7, -0.4)	
Percentage of patients achieving HbA _{1c} <7%	43	17
Fasting Plasma Glucose (mg/dL) (Mean)		
Baseline (week 0)	166	159
Change from baseline (adjusted mean)	-39	-7
Difference from VICTOZA + metformin arm (LS mean) ^b	-31**	
95% Confidence Interval	(-39, -23)	

^aIntent-to-treat population using last observation on study

^bLeast squares mean adjusted for baseline value

**p-value <0.0001

Add-on to Sulfonylurea

In this 26-week trial, 1041 patients were randomized to VICTOZA 0.6 mg, VICTOZA 1.2 mg, VICTOZA 1.8 mg, placebo, or rosiglitazone 4 mg (one-half of the maximal approved dose in the United States), all as add-on to glimepiride. Randomization occurred after a 4-week run-in period consisting of an initial, 2-week, forced-glimepiride titration period followed by a maintenance period of another 2 weeks. During the titration period, doses of glimepiride were increased to 4 mg/day. The doses of glimepiride could be reduced (at the discretion of the investigator) from 4 mg/day to 3 mg/day or 2 mg/day (minimum) after randomization, in the event of unacceptable hypoglycemia or other adverse events.

The mean age of participants was 56 years, and the mean duration of diabetes was 8 years. Participants were 49.4% male, 64.4% White and 2.8% Black or African American. The mean BMI was 29.9 kg/m².

Treatment with VICTOZA 1.2 mg and 1.8 mg as add-on to glimepiride resulted in a statistically significant reduction in mean HbA_{1c} compared to placebo add-on to glimepiride (Table 7). The percentage of patients who discontinued due to ineffective therapy was 3.0% in the VICTOZA 1.8 mg + glimepiride treatment group, 3.5% in the VICTOZA 1.2 mg + glimepiride treatment group, 17.5% in the placebo + glimepiride treatment group, and 6.9% in the rosiglitazone + glimepiride treatment group.

Table 7 Results of a 26-week trial of VICTOZA as add-on to sulfonylurea^a

	VICTOZA 1.8 mg + Glimepiride	VICTOZA 1.2 mg + Glimepiride	Placebo + Glimepiride	Rosiglitazone 4 mg [†] + Glimepiride
Intent-to-Treat Population (N)	234	228	114	231
HbA_{1c} (%) (Mean)				
Baseline	8.5	8.5	8.4	8.4
Change from baseline (adjusted mean) ^b	-1.1	-1.1	+0.2	-0.4
Difference from placebo + glimepiride arm (adjusted mean) ^b	-1.4**	-1.3**		
95% Confidence Interval	(-1.6, -1.1)	(-1.5, -1.1)		
Percentage of patients achieving HbA _{1c} <7%	42	35	7	22

Fasting Plasma Glucose (mg/dL) (Mean)				
Baseline	174	177	171	179
Change from baseline (adjusted mean) ^b	-29	-28	+18	-16
Difference from placebo + glimepiride arm (adjusted mean) ^b	-47**	-46**		
95% Confidence Interval	(-58, -35)	(-58, -35)		
Body Weight (kg) (Mean)				
Baseline	83.0	80.0	81.9	80.6
Change from baseline (adjusted mean) ^b	-0.2	+0.3	-0.1	+2.1
Difference from placebo + glimepiride arm (adjusted mean) ^b	-0.1	0.4		
95% Confidence Interval	(-0.9, 0.6)	(-0.4, 1.2)		

^aIntent-to-treat population using last observation on study

^bLeast squares mean adjusted for baseline value

[†] For rosiglitazone, one-half of the maximal approved United States dose.

**p-value <0.0001

Add-on to Metformin and Sulfonylurea

In this 26-week trial, 581 patients were randomized to VICTOZA 1.8 mg, placebo, or insulin glargine, all as add-on to metformin and glimepiride. Randomization took place after a 6-week run-in period consisting of a 3-week forced metformin and glimepiride titration period followed by a maintenance period of another 3 weeks. During the titration period, doses of metformin and glimepiride were to be increased up to 2000 mg/day and 4 mg/day, respectively. After randomization, patients randomized to VICTOZA 1.8 mg underwent a 2 week period of titration with VICTOZA. During the trial, the VICTOZA and metformin doses were fixed, although glimepiride and insulin glargine doses could be adjusted. Patients titrated glargine twice-weekly during the first 8 weeks of treatment based on self-measured fasting plasma glucose on the day of titration. After Week 8, the frequency of insulin glargine titration was left to the discretion of the investigator, but, at a minimum, the glargine dose was to be revised, if necessary, at Weeks 12 and 18. Only 20% of glargine-treated patients achieved the pre-specified target fasting plasma glucose of ≤ 100 mg/dL. Therefore, optimal titration of the insulin glargine dose was not achieved in most patients.

The mean age of participants was 58 years, and the mean duration of diabetes was 9 years. Participants were 56.5% male, 75.0% White and 3.6% Black or African American. The mean BMI was 30.5 kg/m².

Treatment with VICTOZA as add-on to glimepiride and metformin resulted in a statistically significant mean reduction in HbA_{1c} compared to placebo add-on to glimepiride and metformin (Table 8). The percentage of patients who discontinued due to ineffective therapy was 0.9% in the VICTOZA 1.8 mg + metformin + glimepiride treatment group, 0.4% in the insulin glargine + metformin + glimepiride treatment group, and 11.3% in the placebo + metformin + glimepiride treatment group.

Table 8 Results of a 26-week trial of VICTOZA as add-on to metformin and sulfonylurea^a

	VICTOZA 1.8 mg + Metformin + Glimepiride	Placebo + Metformin + Glimepiride	Insulin glargine[†] + Metformin + Glimepiride
Intent-to-Treat Population (N)	230	114	232
HbA_{1c} (%) (Mean)			
Baseline	8.3	8.3	8.1
Change from baseline (adjusted mean) ^b	-1.3	-0.2	-1.1
Difference from placebo + metformin + glimepiride arm (adjusted mean) ^b	-1.1**		
95% Confidence Interval	(-1.3, -0.9)		
Percentage of patients achieving HbA _{1c} <7%	53	15	46
Fasting Plasma Glucose (mg/dL) (Mean)			
Baseline	165	170	164
Change from baseline (adjusted mean) ^b	-28	+10	-32

Difference from placebo + metformin + glimepiride arm (adjusted mean) ^b	-38**		
95% Confidence Interval	(-46, -30)		
Body Weight (kg) (Mean)			
Baseline	85.8	85.4	85.2
Change from baseline (adjusted mean) ^b	-1.8	-0.4	1.6
Difference from placebo + metformin + glimepiride arm (adjusted mean) ^b	-1.4*		
95% Confidence Interval	(-2.1, -0.7)		

^aIntent-to-treat population using last observation on study

^bLeast squares mean adjusted for baseline value

[†] For insulin glargine, optimal titration regimen was not achieved for 80% of patients.

*p-value <0.05

**p-value <0.0001

VICTOZA Compared to Exenatide, Both as Add-on to Metformin and/or Sulfonylurea Therapy

In this 26-week, open-label trial, 464 patients on a background of metformin monotherapy, sulfonylurea monotherapy or a combination of metformin and sulfonylurea were randomized to once daily VICTOZA 1.8 mg or exenatide 10 mcg twice daily. Maximally tolerated doses of background therapy were to remain unchanged for the duration of the trial. Patients randomized to exenatide started on a dose of 5 mcg twice-daily for 4 weeks and then were escalated to 10 mcg twice daily.

The mean age of participants was 57 years, and the mean duration of diabetes was 8 years. Participants were 51.9% male, 91.8% White, 5.4% Black or African American and 12.3% of Hispanic ethnicity. The mean BMI was 32.9 kg/m².

Treatment with VICTOZA 1.8 mg resulted in statistically significant reductions in HbA_{1c} and FPG relative to exenatide (Table 9). The percentage of patients who discontinued for ineffective therapy was 0.4% in the VICTOZA treatment group and 0% in the exenatide treatment group. Both treatment groups had a mean decrease from baseline in body weight of approximately 3 kg.

Table 9 Results of a 26-week open-label trial of VICTOZA versus Exenatide (both in combination with metformin and/or sulfonylurea)^a

	VICTOZA 1.8 mg once daily + metformin and/or sulfonylurea	Exenatide 10 mcg twice daily + metformin and/or sulfonylurea
Intent-to-Treat Population (N)	233	231
HbA_{1c} (%) (Mean)		
Baseline	8.2	8.1
Change from baseline (adjusted mean) ^b	-1.1	-0.8
Difference from exenatide arm (adjusted mean) ^b	-0.3**	
95% Confidence Interval	(-0.5, -0.2)	
Percentage of patients achieving HbA _{1c} <7%	54	43
Fasting Plasma Glucose (mg/dL) (Mean)		
Baseline	176	171
Change from baseline (adjusted mean) ^b	-29	-11
Difference from exenatide arm (adjusted mean) ^b	-18**	
95% Confidence Interval	(-25, -12)	

^aIntent-to-treat population using last observation carried forward

^bLeast squares mean adjusted for baseline value

**p-value <0.0001

Add-on to Metformin and Thiazolidinedione

In this 26-week trial, 533 patients were randomized to VICTOZA 1.2 mg, VICTOZA 1.8 mg or placebo, all as add-on to rosiglitazone (8 mg) plus metformin (2000 mg). Patients underwent a 9 week run-in period (3-week forced dose escalation followed by a 6-week dose maintenance phase) with rosiglitazone (starting at 4 mg and increasing to 8 mg/day within 2 weeks) and metformin (starting at 500 mg with increasing weekly increments of 500 mg to a final dose of 2000 mg/day). Only patients who tolerated the final dose of rosiglitazone (8 mg/day) and metformin (2000 mg/day) and completed the 6-week dose maintenance phase were eligible for randomization into the trial.

The mean age of participants was 55 years, and the mean duration of diabetes was 9 years. Participants were 61.6% male, 84.2% White, 10.2% Black or African American and 16.4% of Hispanic ethnicity. The mean BMI was 33.9 kg/m².

Treatment with VICTOZA as add-on to metformin and rosiglitazone produced a statistically significant reduction in mean HbA_{1c} compared to placebo add-on to metformin and rosiglitazone (Table 10). The percentage of patients who discontinued due to ineffective therapy was 1.7% in the VICTOZA 1.8 mg + metformin + rosiglitazone treatment group, 1.7% in the VICTOZA 1.2 mg + metformin + rosiglitazone treatment group, and 16.4% in the placebo + metformin + rosiglitazone treatment group.

Table 10 Results of a 26-week trial of VICTOZA as add-on to metformin and thiazolidinedione^a

	VICTOZA 1.8 mg + Metformin + Rosiglitazone	VICTOZA 1.2 mg + Metformin + Rosiglitazone	Placebo + Metformin + Rosiglitazone
Intent-to-Treat Population (N)	178	177	175
HbA_{1c} (%) (Mean)			
Baseline	8.6	8.5	8.4
Change from baseline (adjusted mean) ^b	-1.5	-1.5	-0.5
Difference from placebo + metformin + rosiglitazone arm (adjusted mean) ^b	-0.9**	-0.9**	
95% Confidence Interval	(-1.1, -0.8)	(-1.1, -0.8)	
Percentage of patients achieving HbA _{1c} <7%	54	57	28
Fasting Plasma Glucose (mg/dL) (Mean)			
Baseline	185	181	179
Change from baseline (adjusted mean) ^b	-44	-40	-8
Difference from placebo + metformin + rosiglitazone arm (adjusted mean) ^b	-36**	-32**	
95% Confidence Interval	(-44, -27)	(-41, -23)	
Body Weight (kg) (Mean)			
Baseline	94.9	95.3	98.5
Change from baseline (adjusted mean) ^b	-2.0	-1.0	+0.6
Difference from placebo + metformin + rosiglitazone arm (adjusted mean) ^b	-2.6**	-1.6**	
95% Confidence Interval	(-3.4, -1.8)	(-2.4, -1.0)	

^aIntent-to-treat population using last observation on study

^bLeast squares mean adjusted for baseline value

**p-value <0.0001

VICTOZA Compared to Placebo Both With or Without metformin and/or Sulfonylurea and/or Pioglitazone and/or Basal or Premix insulin in Patients with Type 2 Diabetes Mellitus and Moderate Renal Impairment

In this 26-week, double-blind, randomized, placebo-controlled, parallel-group trial, 279 patients with moderate renal impairment, as per MDRD formula (eGFR 30–59 mL/min/1.73 m²), were randomized to VICTOZA or placebo once daily. VICTOZA was added to the patient's stable pre-trial antidiabetic regimen (insulin therapy and/or metformin, pioglitazone, or sulfonylurea). The dose of VICTOZA was escalated according to approved

labeling to achieve a dose of 1.8 mg per day. The insulin dose was reduced by 20% at randomization for patients with baseline HbA_{1c} ≤ 8% and fixed until liraglutide dose escalation was complete. Dose reduction of insulin and SU was allowed in case of hypoglycemia; up titration of insulin was allowed but not beyond the pre-trial dose.

The mean age of participants was 67 years, and the mean duration of diabetes was 15 years. Participants were 50.5% male, 92.3% White, 6.6% Black or African American, and 7.2% of Hispanic ethnicity. The mean BMI was 33.9 kg/m². Approximately half of patients had an eGFR between 30 and <45mL/min/1.73 m².

Treatment with VICTOZA resulted in a statistically significant reduction in HbA_{1c} from baseline at Week 26 compared to placebo (see Table 11). 123 patients reached the 1.8 mg dose of VICTOZA.

Table 11 Results of a 26-week trial of VICTOZA compared to placebo in Patients with Renal Impairment^a

	VICTOZA 1.8 mg + insulin and/or OAD	Placebo + insulin and/or OAD
Intent to Treat Population (N)	140	137
HbA_{1c} (%)		
Baseline (mean)	8.1	8.0
Change from baseline (estimated mean) ^{b, c}	-0.9	-0.4
Difference from placebo ^{b, c}	-0.6*	
95% Confidence Interval	(-0.8, -0.3)	
Proportion achieving HbA _{1c} < 7% ^d	39.3	19.7
FPG (mg/dL)		
Baseline (mean)	171	167
Change from baseline (estimated mean) ^e	-22	-10
Difference from placebo ^e	-12**	
95% Confidence Interval	(-23, -0.8)	

^a Intent-to-treat population

^b Estimated using a mixed model for repeated measurement with treatment, country, stratification groups as factors and baseline as a covariate, all nested within visit. Multiple imputation method modeled “wash out” of the treatment effect for patients having missing data who discontinued treatment.

^c Early treatment discontinuation, before week 26, occurred in 25% and 22% of VICTOZA and placebo patients, respectively.

^d Based on the known number of subjects achieving HbA_{1c} < 7%. When applying the multiple imputation method described in b) above, the estimated percents achieving HbA_{1c} < 7% are 47.6% and 24.9% for VICTOZA and placebo, respectively.

^e Estimated using a mixed model for repeated measurement with treatment, country, stratification groups as factors and baseline as a covariate, all nested within visit.

*p-value <0.0001

**p-value <0.05

14.2 Glycemic Control Trial in Pediatric Patients 10 Years of Age and Older with Type 2 Diabetes Mellitus

VICTOZA was evaluated in a 26-week, double-blind, randomized, parallel group, placebo controlled multi-center trial (NCT01541215), in 134 pediatric patients with type 2 diabetes aged 10 years and older. Patients were randomized to VICTOZA once-daily or placebo once-daily in combination with metformin with or without basal insulin treatment. All patients were on a metformin dose of 1000 to 2000 mg prior to randomization. The basal insulin dose was decreased by 20% at randomization and VICTOZA was titrated weekly by 0.6 mg for 2 to 3 weeks based on tolerability and an average fasting plasma glucose goal of ≤110 mg/dL.

The mean age was 14.6 years: 29.9% were ages 10-14 years, and 70.1% were greater than 14 years of age. 38.1% were male, 64.9% were White, 13.4% were Asian, 11.9% were Black or African American; 29.1% were of Hispanic or Latino ethnicity. The mean BMI was 33.9 kg/m² and the mean BMI SDS was 2.9. 18.7% of patients were using basal insulin at baseline. The mean duration of diabetes was 1.9 years and the mean HbA_{1c} was 7.8%.

At week 26, treatment with VICTOZA was superior in reducing HbA_{1c} from baseline versus placebo. The estimated treatment difference in HbA_{1c} reduction from baseline between VICTOZA and placebo was -1.06% with a 95% confidence interval of [-1.65%; -0.46%] (see Table 12).

Table 12 Results at week 26 in a trial comparing VICTOZA in combination with metformin with or without basal insulin versus Placebo in combination with metformin with or without basal insulin in Pediatric Patients 10 Years of Age and Older with Type 2 Diabetes Mellitus

	VICTOZA+metformin±basal insulin	Placebo+metformin±basal insulin
N	66	68
HbA_{1c} (%)		
Baseline	7.9	7.7
End of 26 weeks	7.1	8.2
Adjusted mean change from baseline after 26 weeks ^a	-0.64	0.42
Treatment difference [95% CI] VICTOZA vs Placebo	-1.06 [-1.65; -0.46]*	
Percentage of patients achieving HbA _{1c} <7% ^b	63.7	36.5
FPG (mg/dL)		
Baseline	157	147
End of 26 weeks	132	166
Adjusted mean change from baseline after 26 weeks ^a	-19.4	14.4
Treatment difference [95% CI] VICTOZA vs Placebo	-33.83 [-55.74 ; -11.92]	

^a The change from baseline to end of treatment visit in HbA_{1c} and FPG was analyzed using a pattern mixture model with multiple imputation. Missing observations (10.6% in the VICTOZA, 14.5% in the placebo) were imputed from the placebo arm based on multiple (x10,000) imputations. The data for week 26 was then analyzed with an ANCOVA model containing treatment, sex and age group as fixed effects and baseline value as covariate.

^b Categories are derived from continuous measurements of HbA_{1c} using a pattern mixture model with multiple imputation for missing observations.

* p-value <0.001

14.3 Cardiovascular Outcomes Trial in Patients with Type 2 Diabetes Mellitus and Atherosclerotic Cardiovascular Disease

The LEADER trial (NCT01179048) was a multi-national, multi-center, placebo-controlled, double-blind trial. In this study, 9340 patients with inadequately controlled type 2 diabetes and atherosclerotic cardiovascular disease were randomized to VICTOZA 1.8 mg or placebo for a median duration of 3.5 years. The study compared the risk of major adverse cardiovascular events between VICTOZA and placebo when these were added to, and used concomitantly with, background standard of care treatments for type 2 diabetes. The primary endpoint, MACE, was the time to first occurrence of a three part composite outcome which included; cardiovascular death, non-fatal myocardial infarction and non-fatal stroke.

Patients eligible to enter the trial were; 50 years of age or older and had established, stable, cardiovascular, cerebrovascular, peripheral artery disease, chronic kidney disease or NYHA class II and III heart failure (80% of the enrolled population) or were 60 years of age or older and had other specified risk factors for cardiovascular disease (20% of the enrolled population).

At baseline, demographic and disease characteristics were balanced. The mean age was 64 years and the population was 64.3% male, 77.5% Caucasian, 10.0% Asian, and 8.3% Black. In the study, 12.1% of the population identified as Hispanic or Latino. The mean duration of type 2 diabetes was 12.8 years, the mean HbA_{1c} was 8.7% and the mean BMI was 32.5 kg/m². A history of previous myocardial infarction was reported in 31% of randomized individuals, a prior revascularization procedure in 39%, a prior ischemic stroke in 11%, documented symptomatic coronary disease in 9%, documented asymptomatic cardiac ischemia in 26%, and a diagnosis of New York Heart Association (NYHA) class II to III heart failure in 14%. The mean eGFR at baseline was 79 mL/min/1.73 m² and 41.8% of patients had mild renal impairment (eGFR 60 to 90

mL/min/1.73m²), 20.7% had moderate renal impairment (eGFR 30 to 60 mL/min/1.73m²) and 2.4% of patients had severe renal impairment (eGFR < 30 mL/min/1.73m²).

At baseline, patients treated their diabetes with; diet and exercise only (3.9%), oral antidiabetic drugs only (51.5%), oral antidiabetic drugs and insulin (36.7%) or insulin only (7.9%). The most common background antidiabetic drugs used at baseline and in the trial were metformin, sulfonylurea and insulin. Use of DPP-4 inhibitors and other GLP-1 receptor agonists was excluded by protocol and SGLT-2 inhibitors were either not approved or not widely available. At baseline, cardiovascular disease and risk factors were managed with; non-diuretic antihypertensives (92.4%), diuretics (41.8%), statin therapy (72.1%) and platelet aggregation inhibitors (66.8%). During the trial, investigators could modify anti-diabetic and cardiovascular medications to achieve local standard of care treatment targets with respect to blood glucose, lipid, and blood pressure, and manage patients recovering from an acute coronary syndrome or stroke event per local treatment guidelines.

For the primary analysis, a Cox proportional hazards model was used to test for non-inferiority against the pre-specified risk margin of 1.3 for the hazard ratio of MACE and to test for superiority on MACE if non-inferiority was demonstrated. Type 1 error was controlled across multiple tests.

VICTOZA significantly reduced the occurrence of MACE. The estimated hazard ratio (95% CI) for time to first MACE was 0.87 (0.78, 0.97). Refer to Figure 5 and Table 13.

Vital status was available for 99.7% of subjects in the trial. A total of 828 deaths were recorded during the LEADER trial. A majority of the deaths in the trial were categorized as cardiovascular deaths and non-cardiovascular deaths were balanced between the treatment groups (3.5% in patients treated with VICTOZA and 3.6% in patients treated with placebo). The estimated hazard ratio of time to all-cause death for VICTOZA compared to placebo was 0.85 (0.74, 0.97).

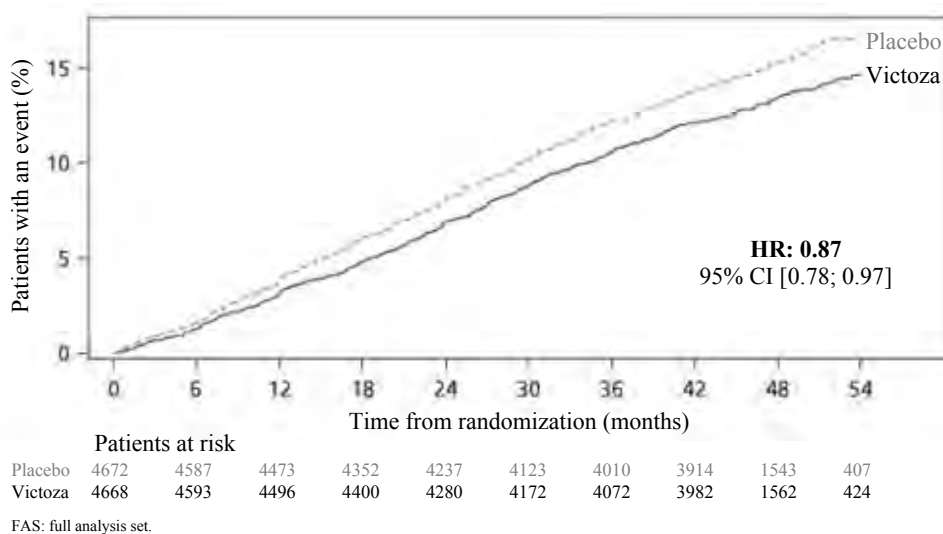

Figure 5 Kaplan-Meier: Time to First Occurrence of a MACE in the LEADER Trial (Patients with T2DM and Atherosclerotic CVD)

Table 13 Treatment Effect for the Primary Composite Endpoint, MACE, and its Components in the LEADER Trial (Patients with T2DM and Atherosclerotic CVD)^a

	VICTOZA N=4668	Placebo N=4672	Hazard Ratio (95% CI)^b
Composite of cardiovascular death, non-fatal myocardial infarction, non-fatal stroke (MACE) (time to first occurrence) ^c	608 (13.0%)	694 (14.9%)	0.87 (0.78; 0.97)
Non-fatal myocardial infarction ^d	281 (6.0%)	317 (6.8%)	0.88 (0.75;1.03)
Non-fatal stroke ^d	159 (3.4%)	177 (3.8%)	0.89 (0.72;1.11)
Cardiovascular death ^d	219 (4.7%)	278 (6%)	0.78 (0.66;0.93)

^aFull analysis set (all randomized patients)

^bCox-proportional hazards model with treatment as a factor

^cp-value for superiority (2-sided) 0.011

^dNumber and percentage of first events

16 HOW SUPPLIED/STORAGE AND HANDLING

16.1 How Supplied

VICTOZA Injection: 18 mg/3 mL (6 mg/mL) clear, colorless solution in a pre-filled, single-patient-use pen that delivers doses of 0.6 mg, 1.2 mg, or 1.8 mg is available in the following package sizes:

2 x VICTOZA pen NDC 0169-4060-12

3 x VICTOZA pen NDC 0169-4060-13

16.2 Recommended Storage

Prior to first use, VICTOZA should be stored in a refrigerator between 36°F to 46°F (2°C to 8°C) (Table 14). Do not store in the freezer or directly adjacent to the refrigerator cooling element. Do not freeze VICTOZA and do not use VICTOZA if it has been frozen.

After first use of the VICTOZA pen, the pen can be stored for 30 days at controlled room temperature (59°F to 86°F; 15°C to 30°C) or in a refrigerator (36°F to 46°F; 2°C to 8°C). Keep the pen cap on when not in use. Discard pen 30 days after first use. VICTOZA should be protected from excessive heat and sunlight. Always remove and safely discard the needle after each injection and store the VICTOZA pen without an injection needle attached. This will reduce the potential for contamination, infection, and leakage while also ensuring dosing accuracy. Always use a new needle for each injection to prevent contamination.

Table 14 Recommended Storage Conditions for the VICTOZA Pen

Prior to first use	After first use	
Refrigerated 36°F to 46°F (2°C to 8°C)	Room Temperature 59°F to 86°F (15°C to 30°C)	Refrigerated 36°F to 46°F (2°C to 8°C)
Until expiration date	30 days	

17 PATIENT COUNSELING INFORMATION

FDA-Approved Medication Guide

See separate leaflet.

Risk of Thyroid C-cell Tumors

Inform patients that liraglutide causes benign and malignant thyroid C-cell tumors in mice and rats and that the human relevance of this finding has not been determined. Counsel patients to report symptoms of thyroid tumors (e.g., a lump in the neck, hoarseness, dysphagia, or dyspnea) to their physician [see *Boxed Warning and Warnings and Precautions (5.1)*].

Dehydration and Renal Failure

Advise patients treated with VICTOZA of the potential risk of dehydration due to gastrointestinal adverse reactions and to take precautions to avoid fluid depletion. Inform patients of the potential risk for worsening renal function, which in some cases may require dialysis.

Pancreatitis

Inform patients of the potential risk for pancreatitis. Explain that persistent severe abdominal pain that may radiate to the back and which may or may not be accompanied by vomiting, is the hallmark symptom of acute pancreatitis. Instruct patients to discontinue VICTOZA promptly and contact their physician if persistent severe abdominal pain occurs [see *Warnings and Precautions (5.2)*].

Acute Gallbladder Disease

Inform patients of the potential risk for cholelithiasis or cholecystitis. Instruct patients to contact their physician if cholelithiasis or cholecystitis is suspected for appropriate clinical follow-up.

Never Share a VICTOZA Pen Between Patients

Advise patients that they must never share a VICTOZA pen with another person, even if the needle is changed, because doing so carries a risk for transmission of blood-borne pathogens.

Hypersensitivity Reactions

Inform patients that serious hypersensitivity reactions have been reported during postmarketing use of VICTOZA. Advise patients on the symptoms of hypersensitivity reactions and instruct them to stop taking VICTOZA and seek medical advice promptly if such symptoms occur [see *Warnings and Precautions (5.6)*].

Jaundice and Hepatitis

Inform patients that jaundice and hepatitis have been reported during postmarketing use of liraglutide. Instruct patients to contact their physician if they develop jaundice.

Instructions

Advise patients that the most common side effects of VICTOZA are headache, nausea and diarrhea. Nausea is most common when first starting VICTOZA, but decreases over time in the majority of patients and does not typically require discontinuation of VICTOZA.

Inform patients not to take an extra dose of VICTOZA to make up for a missed dose. If a dose is missed, the once-daily regimen should be resumed as prescribed with the next scheduled dose. If more than 3 days have elapsed since the last dose, advise the patient to reinitiate VICTOZA at 0.6 mg to mitigate any gastrointestinal symptoms associated with reinitiation of treatment. VICTOZA should be titrated at the discretion of the prescribing physician [see *Dosage and Administration (2)*].

Manufactured by:
Novo Nordisk A/S
DK-2880 Bagsvaerd, Denmark

Date of Issue: August 2020
Version: XX

VICTOZA® is a registered trademark of Novo Nordisk A/S.

PATENT Information: <http://novonordisk-us.com/patients/products/product-patents.html>

© 2010-2020 Novo Nordisk

For information about VICTOZA contact:

Novo Nordisk Inc.
800 Scudders Mill Road
Plainsboro, NJ 08536

1-877-484-2869

Medication Guide
VICTOZA® (VIC-tow-za)
(liraglutide) injection, for subcutaneous use

Read this Medication Guide before you start using VICTOZA and each time you get a refill. There may be new information. This information does not take the place of talking to your healthcare provider about your medical condition or your treatment.

What is the most important information I should know about VICTOZA?

VICTOZA may cause serious side effects, including:

- **Possible thyroid tumors, including cancer.** Tell your healthcare provider if you get a lump or swelling in your neck, hoarseness, trouble swallowing, or shortness of breath. These may be symptoms of thyroid cancer. In studies with rats and mice, VICTOZA and medicines that work like VICTOZA caused thyroid tumors, including thyroid cancer. It is not known if VICTOZA will cause thyroid tumors or a type of thyroid cancer called medullary thyroid carcinoma (MTC) in people.
- Do not use VICTOZA if you or any of your family have ever had a type of thyroid cancer called medullary thyroid carcinoma (MTC), or if you have an endocrine system condition called Multiple Endocrine Neoplasia syndrome type 2 (MEN 2).

What is VICTOZA?

VICTOZA is an injectable prescription medicine used:

- along with diet and exercise to lower blood sugar (glucose) in adults and children who are 10 years of age and older with type 2 diabetes mellitus.
- to reduce the risk of major cardiovascular events such as heart attack, stroke or death in adults with type 2 diabetes mellitus with known heart disease.

VICTOZA is not for use in people with type 1 diabetes or people with diabetic ketoacidosis.

It is not known if VICTOZA can be used with mealtime insulin.

It is not known if VICTOZA is safe and effective to lower blood sugar (glucose) in children under 10 years of age.

Who should not use VICTOZA?

Do not use VICTOZA if:

- you or any of your family have ever had a type of thyroid cancer called medullary thyroid carcinoma (MTC) or if you have an endocrine system condition called Multiple Endocrine Neoplasia syndrome type 2 (MEN 2).
- you are allergic to liraglutide or any of the ingredients in VICTOZA. See the end of this Medication Guide for a complete list of ingredients in VICTOZA.

What should I tell my healthcare provider before using VICTOZA?

Before using VICTOZA, tell your healthcare provider if you have any other medical conditions, including if you:

- have or have had problems with your pancreas, kidneys, or liver.
- have severe problems with your stomach, such as slowed emptying of your stomach (gastroparesis) or problems with digesting food.
- are pregnant or plan to become pregnant. It is not known if VICTOZA will harm your unborn baby. Tell your healthcare provider if you become pregnant while using VICTOZA.
- are breastfeeding or plan to breastfeed. It is not known if VICTOZA passes into your breast milk. You should talk with your healthcare provider about the best way to feed your baby while using VICTOZA.

Tell your healthcare provider about all the medicines you take, including prescription and over-the-counter medicines, vitamins, and herbal supplements. VICTOZA may affect the way some medicines work and some medicines may affect the way VICTOZA works.

Before using VICTOZA, talk to your healthcare provider about low blood sugar and how to manage it. Tell your healthcare provider if you are taking other medicines to treat diabetes, including insulin or sulfonylureas.

Know the medicines you take. Keep a list of them to show your healthcare provider and pharmacist when you get a new medicine.

How should I use VICTOZA?

- Read the **Instructions for Use** that comes with VICTOZA.
- Use VICTOZA exactly as your healthcare provider tells you to.
- **Your healthcare provider should show you how to use VICTOZA before you use it for the first time.**
- **Use VICTOZA 1 time each day, at any time of the day.**
- VICTOZA may be taken with or without food.
- VICTOZA is injected under the skin (subcutaneously) of your stomach (abdomen), thigh, or upper arm. **Do not** inject VICTOZA into a muscle (intramuscularly) or vein (intravenously).
- **Do not mix** insulin and VICTOZA together in the same injection.

- You may give an injection of VICTOZA and insulin in the same body area (such as your stomach area), but not right next to each other.
- If you miss a dose of VICTOZA, take the missed dose at the next scheduled dose. **Do not** take 2 doses of VICTOZA at the same time.
- Change (rotate) your injection site with each injection. **Do not** use the same site for each injection.
- **Do not share your VICTOZA pen with other people, even if the needle has been changed.** You may give other people a serious infection, or get a serious infection from them.
- The VICTOZA pen you are using should be thrown away 30 days after you start using it.

Your dose of VICTOZA and other diabetes medicines may need to change because of:

- change in level of physical activity or exercise, weight gain or loss, increased stress, illness, change in diet, or because of other medicines you take.

What are the possible side effects of VICTOZA?

VICTOZA may cause serious side effects, including:

- **See “What is the most important information I should know about VICTOZA?”**
- **inflammation of your pancreas (pancreatitis).** Stop using VICTOZA and call your healthcare provider right away if you have severe pain in your stomach area (abdomen) that will not go away, with or without vomiting. You may feel the pain from your abdomen to your back.
- **low blood sugar (hypoglycemia).** Your risk for getting low blood sugar may be higher if you use VICTOZA with another medicine that can cause low blood sugar, such as a sulfonylurea or insulin. In children who are 10 years of age and older, the risk for low blood sugar may be higher with VICTOZA regardless of use with another medicine that can also lower blood sugar.

Signs and symptoms of low blood sugar may include:

- | | | |
|---------------------------------|------------------|--|
| ○ dizziness or light-headedness | ○ blurred vision | ○ anxiety, irritability, or mood changes |
| ○ sweating | ○ slurred speech | ○ hunger |
| ○ confusion or drowsiness | ○ shakiness | ○ weakness |
| ○ headache | ○ fast heartbeat | ○ feeling jittery |
- **kidney problems (kidney failure).** In people who have kidney problems, diarrhea, nausea, and vomiting may cause a loss of fluids (dehydration) which may cause kidney problems to get worse.
 - **serious allergic reactions.** Stop using VICTOZA and get medical help right away, if you have any symptoms of a serious allergic reaction including:

○ swelling of your face, lips, tongue or throat	○ fainting or feeling dizzy
○ problems breathing or swallowing	○ very rapid heartbeat
○ severe rash or itching	
 - **gallbladder problems.** Gallbladder problems have happened in some people who take VICTOZA. Tell your healthcare provider right away if you get symptoms of gallbladder problems which may include:

○ pain in the right or middle upper stomach area	○ nausea and vomiting
○ fever	○ your skin or the white part of your eyes turns yellow

The most common side effects of VICTOZA may include: nausea, diarrhea, vomiting, decreased appetite, indigestion and constipation.

Talk to your healthcare provider about any side effect that bothers you or does not go away. These are not all the possible side effects of VICTOZA.

Call your doctor for medical advice about side effects. You may report side effects to FDA at 1-800-FDA-1088.

General information about the safe and effective use of VICTOZA.

Medicines are sometimes prescribed for purposes other than those listed in a Medication Guide. Do not use VICTOZA for a condition for which it was not prescribed. Do not give VICTOZA to other people, even if they have the same symptoms that you have. It may harm them. If you would like more information, talk with your healthcare provider. You can ask your pharmacist or healthcare provider for information about VICTOZA that is written for health professionals.

What are the ingredients in VICTOZA?

Active Ingredient: liraglutide

Inactive Ingredients: disodium phosphate dihydrate, propylene glycol, phenol and water for injection

Manufactured by: Novo Nordisk A/S, DK-2880 Bagsvaerd, Denmark *Victoza*® is a registered trademark of Novo Nordisk A/S.

For more information, go to victoza.com or call 1-877-484-2869. PATENT Information: <http://novonordisk-us.com/patients/products/product-patents.html>

© 2010-2020 Novo Nordisk

Instructions for Use

Victoza (liraglutide) injection

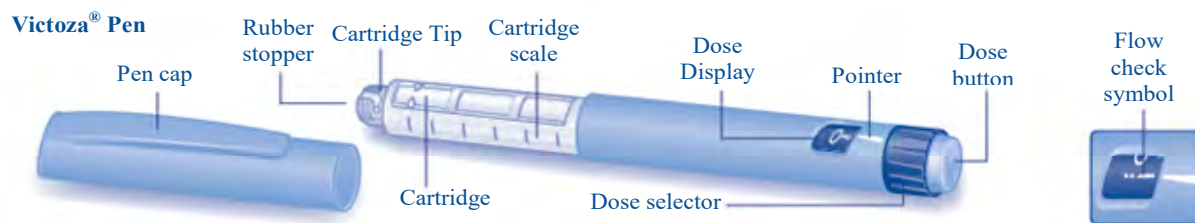

If you are having problems using your Victoza pen, call toll free 1-877-484-2869 or visit victoza.com.

Needle (example)

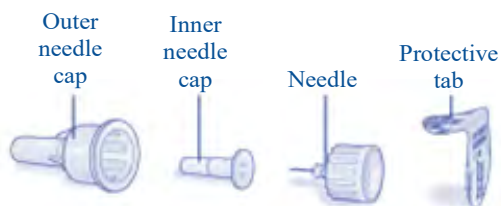

First read the Medication Guide that comes with your Victoza single-patient use pen and then read this Patient Instructions for Use for information about how to use your Victoza pen the right way.

These instructions do not take the place of talking with your healthcare provider about your medical condition or your treatment.

Do not share your Victoza Pen with other people, even if the needle has been changed. You may give other people a serious infection, or get a serious infection from them.

Your Victoza pen is a disposable single-patient-use prefilled pen injector that contains 3 mL of Victoza and will deliver doses of 0.6 mg, 1.2 mg or 1.8 mg. The number of doses that you can take with a Victoza pen depends on the dose of medicine that is prescribed for you. Your healthcare provider will tell you how much Victoza to take.

Victoza pen should be used with Novo Nordisk disposable needles. Talk to your healthcare provider or pharmacist for more information about needles for your Victoza pen.

Important Information

- ▲ Always use a new needle for each injection to prevent contamination.
- ▲ Always remove the needle after each injection, and store your pen without the needle attached. This reduces the risk of contamination, infection, leakage of liraglutide, blocked needles and inaccurate dosing.

- ▲ Keep your Victoza pen and all medicines out of the reach of children.
- ▲ If you drop your Victoza pen, repeat “First Time Use For Each New Pen” (steps A through D).
- ▲ Be careful not to bend or damage the needle.
- ▲ Do not use the cartridge scale to measure how much Victoza to inject.
- ▲ Be careful when handling used needles to avoid needle stick injuries.
- ▲ You can use your Victoza pen for up to 30 days after you use it the first time.

First Time Use for Each New Pen

Step A. Check the Pen

- Take your new Victoza pen out of the refrigerator.
- Wash hands with soap and water before use.
- Check pen label before each use to make sure it is your Victoza pen.
- Pull off pen cap (See Figure A).
- Check Victoza in the cartridge. The liquid should be clear, colorless and free of particles. If not, do not use.
- Wipe the rubber stopper with an alcohol swab.



Step B. Attach the Needle

- Remove protective tab from outer needle cap (See Figure B).
- Push outer needle cap containing the needle straight onto the pen, then screw needle on until secure.
- Pull off outer needle cap (See Figure C). Do not throw away
- Pull off inner needle cap and throw away (See Figure D). A small drop of liquid may appear. This is normal.



Step C. Dial to the Flow Check Symbol

This step is done only **Once** for each new pen and is **Only** required the first time you use a new pen.

- Turn dose selector until flow check symbol (--) lines up with pointer (See Figure E). The flow check symbol does not administer the dose as prescribed by your healthcare provider.
- To select the dose prescribed by your healthcare provider, continue to Step G under "Routine Use".



Step D. Prepare the Pen

- Hold pen with needle pointing up.
- Tap cartridge gently with your finger a few times to bring any air bubbles to the top of the cartridge (See Figure F).
- Keep needle pointing up and press dose button until 0 mg lines up with pointer (See Figure G). Repeat steps C and D, up to 6 times, until a drop of Victoza appears at the needle tip.

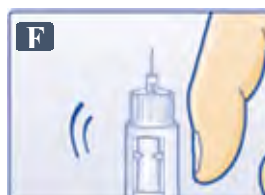

If you still see no drop of Victoza, use a new pen and contact Novo Nordisk at 1-877-484-2869.

Continue to Step G under "Routine Use"
→



Routine Use

Step E. Check the Pen

- Take your Victoza pen from where it is stored.
- Wash hands with soap and water before use.
- Check pen label before each use to make sure it is your Victoza pen.



- Pull off pen cap (See Figure H).
- Check Victoza in the cartridge. The liquid should be clear, colorless and free of particles. If not, do not use.
- Wipe the rubber stopper with an alcohol swab.

Step F. Attach the Needle

- Remove protective tab from outer needle cap.
- Push outer needle cap containing the needle straight onto the pen, then screw needle on until secure (See Figure I).



- Pull off outer needle cap. Do not throw away (See Figure J).



- Pull off inner needle cap and throw away (See Figure K). A small drop of liquid may appear. This is normal.



Step G. Dial the Dose

- Victoza pen can give a dose of 0.6 mg (starting dose), 1.2 mg or 1.8 mg. Be sure that you know the dose of Victoza that is prescribed for you.
- Turn the dose selector until your needed dose lines up with the pointer (0.6 mg, 1.2 mg or 1.8 mg) (See Figure L).

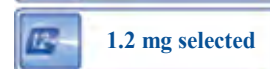
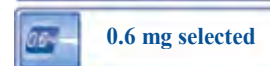

- You will hear a “click” every time you turn the dose selector. **Do not set the dose by counting the number of clicks you hear.**

- If you select a wrong dose, change it by turning the dose selector backwards or forwards until the correct dose lines up with the pointer. Be careful not to press the dose button when turning the dose selector. This may cause Victoza to come out.

Step H. Injecting the Dose

- Insert needle into your skin in the stomach (abdomen), thigh or upper arm. Use the injection technique shown to you by your healthcare provider. **Do not inject Victoza into a vein or muscle.**



- Press down on the center of the dose button to inject until 0 mg lines up with the pointer (See Figure M).
- Be careful not to touch the dose display with your other fingers. This may block the injection.

- Keep the dose button pressed down and make sure that you keep the needle under the skin for a full count of 6 seconds to make sure the full dose is injected. Keep your thumb on the injection button until you remove the needle from your skin (See Figure N).



- Change (rotate) your injection sites within the area you choose for each dose. **Do not** use the same injection site for each injection.

Step I. Withdraw Needle

- You may see a drop of Victoza at the needle tip. This is normal and it does not affect the dose you just received. If blood appears after you take the needle out of your skin, apply light pressure, but **do not rub the area** (See Figure O).



Step J. Remove and Dispose of the Needle

- Carefully put the outer needle cap over the needle (See Figure P). Unscrew the needle.
- Safely remove the needle from your Victoza pen after each use.
- Put your used VICTOZA pen and needles in a FDA-cleared sharps disposal container right away after use. Do not throw away (dispose of) loose needles and pens in your household trash.
- If you do not have a FDA-cleared sharps disposal container, you may use a household container that is:
 - made of a heavy-duty plastic
 - can be closed with a tight-fitting, puncture-resistant lid, without sharps being able to come out
 - upright and stable during use
 - leak-resistant
 - properly labeled to warn of hazardous waste inside the container
- When your sharps disposal container is almost full, you will need to follow your community guidelines for the right way to dispose of your sharps disposal container. There may be state or local laws about how you should throw away used needles and syringes. Do not reuse or share your needles with other people. For more information about the safe sharps disposal, and for specific information about sharps disposal in the state that you live in, go to the FDA's website at: <http://www.fda.gov/safesharpsdisposal>.
- Do not dispose of your used sharps disposal container in your household trash unless your community guidelines permit this. Do not recycle your used sharps disposal container.



Caring for your Victoza pen

- After removing the needle, put the pen cap on your Victoza pen and store your Victoza pen without the needle attached (See Figure Q).
- Do not try to refill your Victoza pen – it is prefilled and is disposable.
- Do not try to repair your pen or pull it apart.

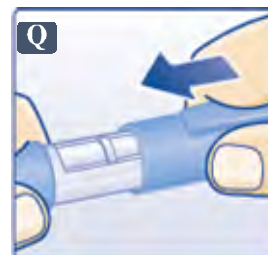

- Keep your Victoza pen away from dust, dirt and liquids.
- If cleaning is needed, wipe the outside of the pen with a clean, damp cloth.

How should I store Victoza?

Before use:

- Store your new, unused Victoza pen in the refrigerator at 36°F to 46°F (2°C to 8°C).
- If Victoza is stored outside of refrigeration (by mistake) prior to first use, it should be used or thrown away within 30 days.
- Do not freeze Victoza or use Victoza if it has been frozen. Do not store Victoza near the refrigerator cooling element.

Pen in use:

- Use a Victoza pen for only 30 days. Throw away a used Victoza pen 30 days after you start using it, even if some medicine is left in the pen.
- Store your Victoza pen at 59°F to 86°F (15°C to 30°C), or in a refrigerator at 36°F to 46°F (2°C to 8°C).
- When carrying the pen away from home, store the pen at a temperature between 59°F to 86°F (15°C to 30°C).
- If Victoza has been exposed to temperatures above 86°F (30°C), it should be thrown away.
- Protect your Victoza pen from heat and sunlight.
- Keep the pen cap on when your Victoza pen is not in use.
- Always remove the needle after each injection and store your pen without the needle attached. This reduces the risk of contamination, infection, leakage and inaccurate dosing.

Victoza[®]
(liraglutide)
injection



PRODUCT MONOGRAPH

Pr **VOTRIENT**[®]

Pazopanib (as pazopanib hydrochloride)

Tablets, 200 mg and 400 mg

Antineoplastic Agent

Novartis Pharmaceuticals Canada Inc.
385 Bouchard Blvd.
Dorval, Quebec
H9S 1A9

Date of Revision:
February 28, 2020

Submission Control No: 234074

VOTRIENT is a registered trademark

TABLE OF CONTENTS

	PAGE
PART I: HEALTH PROFESSIONAL INFORMATION	3
SUMMARY PRODUCT INFORMATION.....	3
INDICATIONS AND CLINICAL USE.....	3
CONTRAINDICATIONS.....	4
WARNINGS AND PRECAUTIONS	5
ADVERSE REACTIONS.....	15
DRUG INTERACTIONS	24
DOSAGE AND ADMINISTRATION.....	28
OVERDOSAGE.....	30
ACTION AND CLINICAL PHARMACOLOGY	30
STORAGE AND STABILITY	33
DOSAGE FORMS, COMPOSITION AND PACKAGING.....	33
PART II: SCIENTIFIC INFORMATION	34
PHARMACEUTICAL INFORMATION.....	34
CLINICAL TRIALS	34
DETAILED PHARMACOLOGY.....	43
TOXICOLOGY.....	43
SAFETY PHARMACOLOGY	46
REFERENCES.....	47
PART III: CONSUMER INFORMATION	48

PrVOTRIENT®

Pazopanib (as pazopanib hydrochloride) tablets

PART I: HEALTH PROFESSIONAL INFORMATION

SUMMARY PRODUCT INFORMATION

Route of Administration	Dosage Form / Strength	Clinically Relevant Nonmedicinal Ingredients
Oral	Tablets / 200 mg, 400 mg	None. <i>For a complete listing see the DOSAGE FORMS, COMPOSITION, AND PACKAGING section.</i>

INDICATIONS AND CLINICAL USE

RENAL CELL CARCINOMA

VOTRIENT (pazopanib hydrochloride) is indicated for the treatment of patients with metastatic renal cell (clear cell) carcinoma (mRCC) as first-line systemic therapy or as second-line systemic therapy after treatment with cytokines for metastatic disease.

Approval of VOTRIENT in mRCC is based on significant progression-free survival benefit in patients with mRCC of good performance status (ECOG 0-1). Prolongation of overall survival was not demonstrated nor were quality-of-life differences shown between patients receiving VOTRIENT versus placebo in the pivotal phase III trial (see PART II, CLINICAL TRIALS).

SOFT TISSUE SARCOMA (STS)

VOTRIENT (pazopanib hydrochloride) is indicated for the treatment of adult patients with selective subtypes of advanced Soft Tissue Sarcoma (STS) who have received prior chemotherapy for metastatic disease or who have progressed within 12 months after (neo) adjuvant therapy.

Patients were required to have disease progression on or after, or be intolerant to, an anthracycline-based regimen in the pivotal phase III study in STS.

The pivotal phase III study in STS was designed to assess VOTRIENT in patients with selected tumour types including: fibroblastic, so-called fibrohistiocytic, leiomyosarcoma, malignant glomus tumours, skeletal muscles, vascular, uncertain differentiation (excluding chondrosarcoma, Ewing tumours / primitive neuroectodermal tumours), malignant peripheral nerve sheath tumours, and undifferentiated soft tissue sarcomas not otherwise specified. However not all of the listed tumour types have been assessed in the clinical study (see CLINICAL TRIALS).

The efficacy and safety of VOTRIENT for the treatment of patients with other STS subtypes, including adipocytic STS (liposarcoma) and gastrointestinal stromal tumours (GIST), have not been demonstrated (see WARNINGS AND PRECAUTIONS and CLINICAL TRIALS).

Clinical effectiveness of VOTRIENT in STS is based on significant progression-free survival benefit in patients with advanced STS. Prolongation of overall survival was not demonstrated nor were quality-of-life differences shown between patients receiving VOTRIENT versus placebo in the pivotal phase III trial (see Part II, CLINICAL TRIALS).

Geriatrics (65 years of age and over):

In clinical trials with VOTRIENT for the treatment of mRCC, 196 patients (33%) were aged ≥ 65 years, and 34 patients (6%) were aged > 75 years. In the STS clinical trials, 93 patients (24%) were aged ≥ 65 years, and 17 subjects (4%) were aged ≥ 75 years. No overall differences in safety or effectiveness of VOTRIENT were observed between these patients and younger patients in clinical trials. However, a meta-analysis shows that patients over 60 years of age may be at greater risk for ALT $> 3 \times$ ULN. Although no other differences in responses between elderly and younger patients have been identified clinically; a greater sensitivity of some older individuals cannot be ruled out.

Pediatrics (Less than 18 years of age):

The safety and efficacy of pazopanib in children have not been established (see WARNINGS AND PRECAUTIONS). Toxicology studies in rodents showed hypertrophy of epiphyseal growth plates and abnormalities in growing incisors and severe effects on body weight gain, organ growth and organ maturation during early post-natal development (see PART II, TOXICOLOGY). VOTRIENT is not recommended for use in children and is contraindicated in children less than 2 years of age (see CONTRAINDICATIONS).

CONTRAINDICATIONS

VOTRIENT (pazopanib hydrochloride) is contraindicated for:

- Patients who are hypersensitive to this drug or to any ingredient in the formulation or component of the container. For a complete listing, see the DOSAGE FORMS, COMPOSITION, AND PACKAGING section of the product monograph.
- Pediatric patients less than 2 year of age. VOTRIENT is an anti-angiogenic agent that severely affects body weight gain, organ growth and organ maturation during early post-natal development in rats (see WARNINGS AND PRECAUTIONS, TOXICOLOGY).

WARNINGS AND PRECAUTIONS

Serious Warnings and Precautions

VOTRIENT tablets should be prescribed by a physician experienced in the administration of anti-cancer agents.

Monitor hepatic function (see Monitoring and Laboratory Tests section below) **and interrupt, reduce or discontinue dosing as recommended** (see Hepatic section below). VOTRIENT should not be used in patients who have baseline plasma bilirubin concentrations > 1.5 X ULN (with direct bilirubin >35%) and ALT elevations of >2 X ULN, or who have moderate or severe hepatic impairment (Child Pugh B and C). Patients over 60 years of age may be at greater risk for ALT >3 X ULN. See Hepatic section below and DOSAGE AND ADMINISTRATION, Hepatic Impairment.

The following are clinically significant adverse events:

- Hepatotoxicity, including fatalities (see Hepatic section below)
- Hypertension, including hypertensive crisis (see Cardiovascular section below)
- Cardiac Dysfunction (see Cardiovascular section below)
- QT/QTc prolongation (see Cardiovascular section below)
- Arterial and Venous Thrombotic Events and Thrombotic Microangiopathy (see Cardiovascular section below)
- Hemorrhage (see Hemorrhagic section below)
- Gastrointestinal Perforation and Fistula (see Gastrointestinal section below)
- Posterior Reversible Encephalopathy Syndrome (PRES/Reversible Posterior Leukoencephalopathy Syndrome (RPLS) (see Neurologic section below)
- Tumour Lysis Syndrome (see Warnings and Precautions and Monitoring and Laboratory Test section)

General

Drug-Drug Interactions: Co-administration of VOTRIENT with strong inhibitors of CYP3A4 or P-glycoprotein (PgP) should be avoided as should co-administration with inhibitors that simultaneously target PgP, the Breast Cancer Resistance Protein (BCRP) and/or CYP3A4. These inhibitors may increase pazopanib concentrations (see DOSAGE AND ADMINISTRATION and DRUG INTERACTIONS) and drug toxicity. Co-administration with inducers of CYP3A4 or PgP or drugs that raise gastric pH should be avoided due to the risk of reduced effectiveness of the drug.

Combination with other systemic anti-cancer therapies: Clinical trials of VOTRIENT in combination with pemetrexed (non-small cell lung cancer (NSCLC)) and lapatinib (cervical cancer) were terminated early due to concerns over increased toxicity and/or mortality, and a safe and effective combination dose has not been established with these regimens. VOTRIENT is not indicated for use in combination with other anti-cancer agents.

Soft Tissue Sarcoma Tumour Types: Only patients with selective histological subtypes of STS were allowed to participate in the studies, therefore efficacy and safety of VOTRIENT can only be considered established for those subgroups of STS and treatment with VOTRIENT should be restricted to such STS subtypes (see INDICATIONS and Clinical Trials).

The following tumour types were excluded in the STS Phase III clinical trial: adipocytic sarcoma (all subtypes), all rhabdomyosarcoma that were not alveolar or pleomorphic, chondrosarcoma, osteosarcoma, Ewing tumours/primitive neuroectodermal tumours, GIST, dermatofibromatosis sarcoma protuberans, inflammatory myofibroblastic sarcoma, malignant mesothelioma and mixed mesodermal tumours of the uterus.

Patients with adipocytic sarcoma (liposarcoma) were excluded from the pivotal phase III study, since in a phase II study (VEG20002), activity (PFS at week12) observed with VOTRIENT in adipocytic tumours was indeterminant (see CLINICAL TRIALS). Patients with the other tumour types listed above were excluded due to the unique pathogenesis and treatment options for these tumour types.

The pivotal phase III study excluded patients who have been previously treated with inhibitors of angiogenesis and/or VEGF or VEGFR-targeting agents.

Carcinogenesis and Mutagenesis

In two year carcinogenicity studies with pazopanib, there were increased incidences of liver adenomas in mice (at doses approximately 1.3 times human therapeutic exposure) and duodenal adenocarcinomas in rats (at doses ≥ 0.3 times human therapeutic exposure). The human relevance of these neoplastic findings in mice and rats is unclear. Genotoxicity studies showed no evidence of clastogenic or mutagenic activity (see PART II, TOXICOLOGY; Carcinogenesis, Mutagenesis, Impairment of Fertility).

Cardiovascular

Hypertension: Hypertension is a common adverse event in patients treated with VOTRIENT and blood pressure should be well controlled prior to initiating treatment with VOTRIENT. Patients were required to have diastolic BP \leq 90 mm Hg and systolic BP \leq 140 mm Hg for entry into the controlled phase III trial. During therapy patients should be monitored for hypertension early after starting treatment (no longer than one week after starting VOTRIENT) and frequently thereafter to ensure blood pressure control, and treated promptly with a combination of standard anti-hypertensive therapy and VOTRIENT dose reduction or interruption as clinically warranted (see DOSAGE AND ADMINISTRATION).

In controlled clinical studies with VOTRIENT for the treatment of RCC and STS, approximately 40% of patients who received VOTRIENT compared with 6% and 10% of patients, respectively, on placebo experienced hypertension. Grade 3 hypertension was reported in 4% and 7% in those receiving VOTRIENT compared with 0.7% on placebo. Hypertension (systolic blood pressure \geq 150 or diastolic blood pressure \geq 100 mm Hg) occurred early in the course of VOTRIENT treatment (approximately 40% of cases occurred by Day 9 and approximately 90% of cases occurred in the first 18 weeks). The majority of cases of hypertension were manageable with anti-hypertensive agents or dose reduction with (0.7%) permanently discontinuing treatment with VOTRIENT.

Hypertensive crisis was originally reported with VOTRIENT in the overall safety population for mRCC (1/586). Additional reports of hypertensive crisis have been received from the overall VOTRIENT clinical development program. These events have occurred in patients with or without a history of hypertension.

Patients with hypertension that is not controlled by medications should not be treated with VOTRIENT. VOTRIENT should be discontinued if there is evidence of hypertensive crisis or if hypertension is severe and persists despite anti-hypertensive therapy and VOTRIENT dose reduction.

Serious cases of artery dissection have been reported in patients using VEGFR TKIs, including VOTRIENT, with or without hypertension.

Cardiac Dysfunction: In three clinical trials with VOTRIENT for mRCC, events of cardiac dysfunction such as congestive heart failure and decreased left ventricular ejection fraction (LVEF) have occurred. In the overall safety population for mRCC (N = 586), cardiac dysfunction was observed in 4/586 patients (<1%). LVEF was not monitored in these clinical studies for mRCC; however the rates of cardiac dysfunction were similar between the placebo and VOTRIENT arms. In a separate randomised mRCC trial of VOTRIENT compared with sunitinib, cardiac dysfunction was defined as symptoms of cardiac dysfunction or \geq 15% absolute decline in LVEF compared with baseline or a decline in LVEF of \geq 10% compared with baseline that is also below the lower limit of normal. In patients who had baseline and follow-up LVEF measurements, cardiac dysfunction occurred in 13% (47/362) of patients on VOTRIENT compared to 11% (42/369) of patients on sunitinib. Congestive heart failure was observed in 0.5% of

patients on each arm. In the phase III STS clinical trial, congestive heart failure was reported in 3 out of 240 patients (1%). In this trial, decreases in LVEF in patients who had post-baseline measurement were detected in 11% (16/142) in the VOTRIENT arm compared with 5% (2/40) in the placebo arm. Fourteen of the 16 patients in the VOTRIENT arm had concurrent hypertension. VOTRIENT has not been studied in patients with moderate to severe heart failure or a below normal LVEF.

Patients should be carefully monitored for clinical signs or symptoms of congestive heart failure. Baseline and periodic evaluation of LVEF is recommended in patients at risk of cardiac dysfunction including those who have received prior anthracyclines. Blood pressure should be monitored and managed promptly using a combination of anti-hypertensive therapy and dose modification of VOTRIENT (interruption and re-initiation at a reduced dose based on clinical judgment).

QT Prolongation and Torsade de Pointes: In clinical studies for VOTRIENT in mRCC and STS patients, QT prolongation (≥ 500 msec) was identified on routine electrocardiogram monitoring in 1.0% of mRCC patients (3/290) and $<1\%$ of STS patients (1/240) compared with no patients on placebo. Torsade de Pointes occurred in 2/586 (0.3%) patients who received VOTRIENT in the mRCC clinical studies. VOTRIENT should be used with caution in patients with a history of QT interval prolongation, patients taking antiarrhythmics or other medications that may potentially prolong QT interval, or those with relevant pre-existing cardiac disease (including myocardial ischemia and congestive heart failure). Other risk factors for Torsade de Pointes include diabetes mellitus, autonomic neuropathy and electrolyte disturbances (hypokalemia, hypomagnesemia, hypocalcemia). When using VOTRIENT, baseline and periodic monitoring of electrocardiograms should be performed and electrolytes should be maintained within the normal range.

Decreased Heart Rate: In a placebo controlled cardiac conduction study in patients with solid tumours (N=65), VOTRIENT treatment resulted in decreased heart rate compared to placebo treatment (see DRUG INTERACTIONS; ACTION AND CLINICAL PHARMACOLOGY, Cardiovascular). Symptomatic bradycardia was reported rarely ($<0.1\%$) based on a review of the pazopanib clinical trial safety database. VOTRIENT should be used with caution in patients with a low heart rate at baseline (<60 beats per minute), a history of syncope or arrhythmia, sick sinus syndrome, sinoatrial block, atrioventricular (AV block), ischemic heart disease, or congestive heart failure. Medicinal products that result in a decrease in heart rate should be used with caution if administered concomitantly with VOTRIENT.

Arterial Thrombotic Events: In clinical studies for VOTRIENT, myocardial infarctions, angina, ischemic stroke and transient ischemic attack were observed, some of which were fatal. In the controlled phase III RCC and STS studies, these events were observed more frequently in patients treated with VOTRIENT in the RCC trial 9/290 (3%) and in the STS trial 5/240 (2%) while none were observed in patients receiving placebo. The events included myocardial infarction/ischemia 5/290 (1.7%) and 4/240 (2%); cerebral vascular accident 1/290 (0.3%) and 1/240 (0.4%); and transient ischemic attack 4/290 (1.4%) and none, in the RCC and the STS trials, respectively). Fatal arterial

thrombotic events occurred in 2/290 (0.7%, ischemic stroke and myocardial ischemia) of patients treated with VOTRIENT and none receiving placebo in the RCC trial. No fatal arterial thrombotic events occurred in the STS trial. VOTRIENT should be used with caution in patients who are at increased risk of thrombotic events or who have had a history of thrombotic events. VOTRIENT has not been studied in patients who have had an event within the previous 6 months and should not be used in these patients.

Venous Thromboembolic Events: In clinical studies with VOTRIENT, venous thromboembolic events including venous thrombosis and fatal pulmonary embolus have occurred. The incidence was higher in the STS population (5 %) than in the RCC population (2 %). In the pivotal trial in the STS population, the incidences of venous thromboembolic events were 5% in patients treated with VOTRIENT compared with 2% with placebo. In the pivotal clinical trial in the mRCC population, the incidences of venous thromboembolic events were 1% in patients treated with VOTRIENT compared with 1% with placebo. Monitor for signs and symptoms of venous thromboembolic events and pulmonary embolism.

Thrombotic Microangiopathy: Thrombotic microangiopathy (TMA) [including cases identified as thrombotic thrombocytopenic purpura (TTP) and haemolytic uraemic syndrome (HUS)] has been reported in clinical trials and in post-marketing experience of VOTRIENT as monotherapy in combination with bevacizumab (see Adverse Reactions, Clinical Trial Adverse Drug Reactions Post-marketing Adverse Reactions). Permanently discontinue VOTRIENT in patients developing TMA. Reversal of the effects of TMA has been observed after treatment was discontinued consistent with a role reported for inhibitors of the VEGF pathway in this event. VOTRIENT is not indicated for use in combination with other agents.

Endocrine and Metabolism

Hypothyroidism: In clinical studies with VOTRIENT, events of hypothyroidism have occurred. Hypothyroidism was reported as an adverse reaction in 19 patients (7%) treated with VOTRIENT and no patients (0%) in the placebo arm in the mRCC trial and in 19 patients (8 %) treated with VOTRIENT and no patients (0%) for placebo in the STS trial.

Proactive monitoring of thyroid function tests is recommended.

Gastrointestinal

Gastrointestinal Perforations and Fistula: In clinical studies for VOTRIENT, events of gastrointestinal (GI) perforation or fistula have occurred, some of which were fatal. In the RCC and STS trials, gastrointestinal perforation or fistula occurred in 0.9% (5/586) of patients and 1% (4/382) of patients receiving VOTRIENT, respectively. Fatal perforations occurred in 0.3% (2/586) of these patients in the RCC trials and in 0.3% (1/382) of these patients in the STS trials. VOTRIENT should be used with caution in patients at risk for GI perforation or fistula. Monitor for signs and symptoms of gastrointestinal perforation or fistula.

Hemorrhagic

In clinical studies with VOTRIENT, hemorrhagic events have been reported, some of which were fatal. In the controlled clinical study with VOTRIENT for the treatment of mRCC, 37/290 patients (13%) treated with VOTRIENT and 7/145 patients (5%) on placebo experienced at least 1 hemorrhagic event. The most common hemorrhagic events in the patients treated with VOTRIENT were hematuria (4%), epistaxis (2%), hemoptysis (2%), and rectal hemorrhage (1%). Nine (9/37) patients treated with VOTRIENT who had hemorrhagic events experienced serious events including pulmonary, gastrointestinal, and genitourinary hemorrhage. In the overall safety populations for mRCC (N=586), cerebral hemorrhage was observed in <1% of patients treated with VOTRIENT and fatal hemorrhage occurred in 0.9% patients.

In a clinical trial of VOTRIENT for the treatment of STS, 53/240 (22%) of patients treated with VOTRIENT compared to 10/123 (8%) treated with placebo experienced at least 1 hemorrhagic event. The most common hemorrhagic events were epistaxis (8%), mouth hemorrhage (3%), and anal hemorrhage (2%). Grade 4 hemorrhagic events occurred in 1% (3/240) of patients and included intracranial hemorrhage, subarachnoid hemorrhage and peritoneal hemorrhage.

VOTRIENT has not been studied in patients who had a history of hemoptysis, cerebral, or clinically significant gastrointestinal hemorrhage in the past 6 months. Treatment with VOTRIENT is not recommended if there is a history of hemoptysis, cerebral or clinically significant gastrointestinal bleeding in the past 6 months, and VOTRIENT should be used with caution in patients with a significant risk of hemorrhage.

Hepatic

Hepatic Effects: Cases of hepatic failure (including fatalities) have been reported during use of VOTRIENT. In clinical trials with VOTRIENT that supported initial mRCC approval, increases in serum transaminases [ALT, aspartate aminotransferase (AST)] and bilirubin were observed. In the majority of the cases, isolated increases in ALT and AST have been reported, without concomitant elevations of alkaline phosphatase or bilirubin. Based on a meta-analysis, patients over 60 years of age may be at greater risk for ALT >3 X ULN. Patients who carry the HLA-B*57:01 allele also have an increased risk of pazopanib-associated ALT elevations. Liver function should be monitored in all patients receiving pazopanib, regardless of genotype or age. A careful risk/benefit assessment should be made for patients known to be carrying the HLA-B*57:01 allele (see Action and Clinical Pharmacology, Pharmacogenomics). The vast majority (over 90 %) of all transaminase elevations of any grade occurred in the first 18 weeks. Grades are based on the National Cancer Institute Common Terminology Criteria for Adverse Events, Version 3 (NCI CTCAE).

In the controlled phase III clinical study with VOTRIENT for the treatment of mRCC, ALT >3x ULN was reported in 18% and 3% of patients who received VOTRIENT and placebo, respectively. ALT >10x ULN was reported in 4% of patients who received VOTRIENT and in <1% of placebo patients. Concurrent elevation in ALT >3x ULN and

bilirubin >2x ULN in the absence of significant alkaline phosphatase elevation occurred in 1% of patients on VOTRIENT and <1% on placebo. In patients who discontinued study treatment due to an adverse event, hepatic related effects were the most common reasons for study discontinuation in the phase III controlled clinical trial (4%) and in the phase II single-arm study (4%).

In a controlled clinical trial of VOTRIENT for the treatment of STS, ALT >3 X ULN was reported in 18% and 5% of the VOTRIENT and placebo groups, respectively. ALT > 8 X ULN was reported in 7% and 2% of the VOTRIENT and placebo groups, respectively. Concurrent elevation in ALT >3 X ULN and bilirubin >2 X ULN in the absence of significant alkaline phosphatase >3 X ULN occurred in 4/240 (2%) of patients on VOTRIENT and 1/123 (<1%) on placebo.

One third of a percent (0.3%) of the patients (2/586) from trials that supported the RCC indication died with disease progression and hepatic failure, and 0.4% of patients (1/240) in the STS trial died of hepatic failure.

Monitor serum liver tests before initiation of treatment with VOTRIENT, at weeks 2, 4, 6 and 8, at Month 3 and at Month 4, and as clinically indicated. Periodic monitoring should then continue after Month 4. Physicians should inform patients on the possible signs and symptoms of hepatic dysfunction (including jaundice, unusual darkening of the urine, anorexia, nausea, fatigue, right upper abdominal discomfort and vomiting) so appropriate management can be implemented to minimize this impact.

The following guidelines are provided for patients with baseline values of total bilirubin ≤ 1.5 X ULN and AST and ALT ≤ 2 X ULN.

- Patients with isolated ALT elevations between 3 X ULN and ≤ 8 X ULN may be continued on VOTRIENT with weekly monitoring of liver function until ALT returns to Grade 1 (NCI CTCAE) or baseline.
- Patients with ALT of >8 X ULN should have VOTRIENT interrupted until they return to Grade 1 (NCI CTCAE) or baseline. If the potential benefit for reinitiating VOTRIENT treatment is considered to outweigh the risk for hepatotoxicity, then reintroduce VOTRIENT at a reduced dose of 400 mg once daily and measure serum liver tests weekly for 8 weeks (see DOSAGE AND ADMINISTRATION). Following reintroduction of VOTRIENT, if ALT elevations >3 X ULN recur, then VOTRIENT should be permanently discontinued.
- If ALT elevations >3 X ULN occur concurrently with bilirubin elevations >2 X ULN, VOTRIENT should be permanently discontinued. Patients should be monitored until return to Grade 1 (NCI CTCAE) or baseline. VOTRIENT is a UGT1A1 inhibitor. Mild, indirect (unconjugated) hyperbilirubinaemia may occur in patients with Gilbert's syndrome. Patients with only a mild indirect hyperbilirubinaemia, known or suspected Gilbert's syndrome, and elevation in ALT > 3 X ULN should be managed as per the recommendations outlined for isolated ALT elevations.

- For isolated hyperbilirubinemia (i.e., in the absence of elevated ALT or other signs/symptoms of liver injury) treatment could continue and dose modification is not required. However, further evaluation for a possible underlying cause should be considered.

Concomitant use of VOTRIENT and simvastatin increases the risk of ALT elevations (see Drug-Drug Interactions) and should be undertaken with caution and close monitoring. In addition, caution and close monitoring should be undertaken with concomitant use of VOTRIENT and other statins as there are currently insufficient data available to assess their impact on ALT levels.

Hepatic Impairment: In a phase I hepatic impairment study, patients with moderate hepatic impairment at baseline experienced dose limiting toxicity at 400 mg (half the recommended daily dose). VOTRIENT should not be used in patients with baseline plasma bilirubin concentrations $> 1.5 \times \text{ULN}$ (with direct bilirubin $> 35\%$) and ALT elevations of $> 2 \times \text{ULN}$, or who have moderate or severe hepatic impairment (Child Pugh B and C). VOTRIENT should be used with caution in patients with mild hepatic impairment as no formal studies have been carried out in this patient population.

Infections

Cases of serious infections (with or without neutropenia), in some cases with fatal outcome, have been reported. Institute appropriate anti-infective therapy promptly and consider interruption or discontinuation of VOTRIENT for serious infections.

Ophthalmologic

In the post-marketing setting, cases of non-exudative retinal detachment have been reported in patients treated with VOTRIENT. Reports indicated that, after treatment, many cases of retinal detachment resolved and therapy with VOTRIENT was continued or resumed; however, recurrence has been noted.

Neurological

Posterior reversible encephalopathy syndrome (PRES) /Reversible Posterior Leukoencephalopathy Syndrome (RPLS): PRES/RPLS has been reported in patients receiving VOTRIENT and may be fatal. There was a history or new onset of hypertension, often severe, at the time of the event in all reports. PRES/RPLS occurred within 90 days of initiating VOTRIENT.

PRES/RPLS is a neurological disorder which can present with headache, seizure, lethargy, confusion, blindness and other visual and neurologic disturbances. Mild to severe hypertension may not be present in all cases of PRES/RPLS. The diagnosis of RPLS is optimally confirmed by magnetic resonance imaging. Permanently discontinue VOTRIENT in patients developing PRES/RPLS.

Peri-Operative Considerations

Wound Healing: No formal studies on the effect of VOTRIENT on wound healing have been conducted. Since Vascular Endothelial Growth Factor (VEGF) inhibitors may impair wound healing, treatment with VOTRIENT should be stopped at least 7 days prior to scheduled surgery. The decision to resume VOTRIENT after surgery should be based on clinical judgement of adequate wound healing. VOTRIENT should be discontinued in patients with wound dehiscence.

Renal

Proteinuria: In clinical studies with VOTRIENT proteinuria and nephrotic syndrome have been reported. In the controlled phase III clinical study with VOTRIENT for the treatment of mRCC, proteinuria was reported as an adverse reaction in 27 patients (9%) treated with VOTRIENT. In the controlled clinical trial for the treatment of STS, proteinuria was reported in 1% of patients treated with VOTRIENT and in 3% treated with placebo. One patient (1/240, 0.4%) treated with VOTRIENT experienced nephrotic syndrome and was withdrawn from treatment. Baseline and periodic urinalyses during treatment are recommended and patients should be monitored for worsening proteinuria with measurement of 24-hour urine protein as clinically indicated. Interrupt VOTRIENT and dose reduce for 24-hour urine protein ≥ 3 grams; discontinue VOTRIENT for repeat episodes despite dose reductions. VOTRIENT should be discontinued if the patient develops nephrotic syndrome. Patients with > 1 g protein (24 h collection) at baseline were excluded from clinical studies.

Reproduction

VOTRIENT may impair fertility in human males and females. In female reproductive toxicity studies in rats, reduced female fertility has been observed (see PART II, TOXICOLOGY).

Respiratory

Pneumothorax: In the mRCC and STS pivotal trials, pneumothorax was seen in patients treated with VOTRIENT and in no patients in the placebo groups. All patients with pneumothorax had lung metastases at baseline.

Interstitial Lung Disease (ILD)/Pneumonitis: Cases of ILD/pneumonitis, including fatalities, have been reported in association with VOTRIENT. Ground glass opacities were detected in some patients upon CT scan, with some patients presenting with symptoms such as dyspnea, cough or fever. Monitor patients for pulmonary symptoms indicative of ILD/pneumonitis and discontinue VOTRIENT in patients developing ILD or pneumonitis. Advise patients to promptly report any new or worsening respiratory symptoms.

Endocrine and Metabolism

Tumour lysis syndrome (TLS): Cases of TLS, including fatal cases, have been reported in patients treated with VOTRIENT (see Adverse Reactions, Post-marketing Adverse Reactions). Patients generally at risk of TLS are those with rapidly growing tumours, a high tumour burden, renal dysfunction, or dehydration. Preventative measures such as treatment of high uric acid levels and intravenous hydration should be considered prior to initiation of VOTRIENT. Patients at risk should be closely monitored for signs and symptoms of TLS and treated as clinically indicated.

Special Populations

Ethnicity: Neutropenia, thrombocytopenia and palmar-plantar erythrodysesthesia syndrome were observed more frequently in patients of East Asian descent.

Pregnant Women: Pre-clinical studies in animals have shown that pazopanib was teratogenic, embryotoxic, fetotoxic and abortifacient (see PART II TOXICOLOGY). Clinical trials have not been conducted in pregnant women.

VOTRIENT may cause fetal harm when administered to pregnant women. If VOTRIENT is used during pregnancy, or if the patient becomes pregnant while receiving VOTRIENT, the potential hazard to the fetus should be explained to the patient. Women of childbearing potential should be advised to avoid becoming pregnant while receiving treatment with VOTRIENT and for up to 8 weeks after ending treatment.

It is not known whether VOTRIENT is present in semen. Male patients (including those who have had vasectomies) with sexual partners who are pregnant, possibly pregnant, or who could become pregnant should use condoms during sexual intercourse while taking pazopanib and for at least 2 weeks after the last dose of drug.

Nursing Women: The safe use of VOTRIENT during lactation has not been established. It is not known whether VOTRIENT is excreted in human milk. Breastfeeding should be discontinued during treatment with VOTRIENT.

Pediatrics: The safety and efficacy of VOTRIENT in children less than 18 years of age have not been established. Toxicology studies in rodents showed hypertrophy of epiphyseal growth plates and abnormalities in growing incisors. In addition, a juvenile toxicity study in rats aged 9 to 14 days post-partum dosed at 10 and 100 mg/kg/day (equal to approximately 0.16x and 0.43x human clinical exposure based on AUC in adults, respectively) showed profound effects on organ growth and maturation, including decreased organ weights and glomerulopathy. A dose level of 10 mg/kg/day resulted in severely decreased body weight gain. A dose level of 100 mg/kg/day resulted in deaths, a lack of body weight gain, and decreased cell proliferation and increased cell apoptosis in various organs (see PART II, TOXICOLOGY).

VOTRIENT is not recommended for use in children less than 18 years of age. VOTRIENT is contraindicated in children younger than 2 years of age (see PART I, CONTRAINDICATIONS).

Monitoring and Laboratory Tests

Prior to treatment and during the course of therapy with VOTRIENT patients should be monitored for hypertension and standard anti-hypertensive therapy should be initiated as required. Normal blood pressure (diastolic ≤ 90 mm Hg and systolic ≤ 140 mm Hg), confirmed by two measurements separated by 24 hours, should be recorded for patients prescribed anti-hypertensive medication prior to treatment with VOTRIENT. Baseline and periodic evaluation of LVEF is recommended in patients at risk of cardiac dysfunction including those who have received prior anthracyclines.

ECG evaluations should be performed at baseline and periodically during treatment with VOTRIENT to monitor for decreased heart rate and ECG intervals (see ACTION AND CLINICAL PHARMACOLOGY, Cardiovascular).

When using VOTRIENT, complete blood counts (CBC), clinical chemistries [including blood glucose, lipase/amylase, creatinine and electrolytes (calcium, magnesium, potassium, phosphate and sodium)], urinalyses and electrocardiograms should be measured at baseline and periodically during treatment.

Proactive monitoring of thyroid function tests is recommended.

Signs and symptoms consistent with TLS (e.g., hyperuricemia, hyperkalemia, hypocalcemia, hyperphosphatemia, acute renal failure, elevated LDH, high fevers) should be monitored at baseline and during initial treatment with VOTRIENT for patients at risk. Patients' hydration status should be monitored closely. Adequate hydration should be maintained if TLS is considered a substantial risk.

Monitor serum liver tests before initiation of treatment with VOTRIENT at weeks 2, 4, 6, and 8, at Month 3 and at Month 4, and as clinically indicated. Periodic monitoring should then continue after Month 4 (see WARNINGS AND PRECAUTIONS; Hepatic Effects, and Hepatic Impairment).

ADVERSE REACTIONS

Adverse Drug Reaction Overview

The safety of VOTRIENT has been evaluated in more than 1600 patients in clinical trials including 977 patients in the monotherapy studies which include 586 mRCC patients. The mRCC data described below reflect exposure to VOTRIENT in 290 mRCC patients who participated in a randomized, double-blind, placebo-controlled study (VEG105192). The median duration of treatment was 7.4 months for patients who received VOTRIENT

and 3.8 months for the placebo arm. Forty-two percent (42%) of patients on VOTRIENT required a dose interruption and thirty-six percent (36%) required a dose reduction.

The safety and efficacy of VOTRIENT in soft tissue sarcoma (STS) were evaluated in a randomized, double-blind, placebo-controlled multi-centre study (VEG110727). Patients (N = 369) with advanced STS who had received prior anthracycline treatment, or were unsuited for such therapy, were randomized to receive VOTRIENT 800 mg once daily (N = 246) or placebo (N = 123). The median duration of treatment was 4.5 months for the VOTRIENT arm and 1.9 months for the placebo arm.

Clinical Trial Adverse Drug Reactions

Potentially serious adverse reactions with VOTRIENT included hepatic effects, hypertension, QT prolongation and Torsade de Pointes, arterial and venous thrombotic events, cardiac dysfunction, hemorrhagic events and gastrointestinal perforation and fistula (see WARNINGS AND PRECAUTIONS). Other important serious adverse reactions identified in STS trials included venous thromboembolic events and pneumothorax.

Metastatic Renal Cell Carcinoma

Table 1 presents the most common adverse reactions occurring in $\geq 10\%$ of patients who received VOTRIENT in the pivotal mRCC study.

Table 1 Adverse Reactions Occurring in $\geq 10\%$ of mRCC Patients who Received VOTRIENT (Study VEG105192)

Reactions	VOTRIENT (N = 290)			Placebo (N = 145)		
	All Grades* %	Grade 3 %	Grade 4 %	All Grades* %	Grade 3 %	Grade 4 %
Gastrointestinal disorders						
Diarrhea	52	3	<1	9	<1	0
Nausea	26	<1	0	9	0	0
Vomiting	21	2	<1	8	2	0
Abdominal pain	11	2	0	1	0	0
Vascular disorders						
Hypertension	40	4	0	10	<1	0
General disorders and administrative site conditions						
Fatigue	19	2	0	8	1	1
Asthenia	14	3	0	8	0	0
Skin and subcutaneous tissue disorders						
Hair colour changes	38	<1	0	3	0	0
Metabolism and nutrition disorders						
Anorexia	22	2	0	10	<1	0
Nervous system disorder						
Headache	10	0	0	5	0	0

* National Cancer Institute Common Terminology Criteria for Adverse Events, version 3.

Other notable treatment-emergent adverse reactions in mRCC patients with an incidence <10% (all grades) include:

Blood and lymphatic system disorders: thrombocytopenia (8%), neutropenia (5%), leucopenia (3%), lymphopenia (2%)

Cardiac disorders: myocardial ischaemia* (1%), QT Prolongation* (1%), myocardial infarction/ischemia* (1.7%), Torsade de Pointes* (<1%), cardiac dysfunction* (<1%), myocardial infarction* (<1%)

Endocrine disorders: hypothyroidism* (7%)

Gastrointestinal disorders: dyspepsia (5%), stomatitis (4%), flatulence (3%), gastrointestinal perforations* (<1%), gastrointestinal fistula* (<1%)

General disorders and administration site conditions: chest pain (5%)

Hepatobiliary disorders: hyperbilirubinemia* (4%), abnormal hepatic function* (3%), hepatotoxicity (2%)

Infections and infestations: urinary tract infection (4%)

Investigations: weight decreased (9%)

Metabolism and nutrition disorders: hyperkalemia (3%)

Nervous system disorders: dysguesia (altered taste 8%), paraesthesia (3%), transient ischemic attack* (1.4%), cerebral vascular accident (<1%)

Renal and urinary disorders: proteinuria* (9%), dysuria (2%)

Respiratory, thoracic and mediastinal disorders: epistaxis (2%), dysphonia (4%), pneumothorax* (<1%)

Skin and subcutaneous disorders: alopecia (8%), rash (8%), palmar-plantar erythrodysesthesia (hand-foot syndrome 6%), skin depigmentation (3%), hyperhidrosis (3%)

Vascular disorders: hematuria (4%), epistaxis (2%), hemoptysis* (2%), rectal hemorrhage* (1%), venous thromboembolic events (1%), cerebral haemorrhage* (<1%), pulmonary hemorrhage* (<1%), genitourinary hemorrhage* (<1%), anal hemorrhage (<1%), gastric hemorrhage (<1%), hematemesis (<1%), hematochezia (<1%), melena (<1%), esophageal hemorrhage (<1%)

*see WARNINGS AND PRECAUTIONS for additional information

Soft Tissue Sarcoma

Table 2 presents the most common adverse reactions occurring in $\geq 10\%$ of patients who received VOTRIENT in the pivotal STS study.

Table 2 Adverse Reactions Occurring in $\geq 10\%$ of patients with STS who Received VOTRIENT (study VEG110727)

Adverse Reactions	VOTRIENT			Placebo		
	(N = 240)			(N = 123)		
	All Grades ^a	Grade 3	Grade 4	All Grades ^a	Grade 3	Grade 4
	%	%	%	%	%	%
Fatigue	65	13	<1	48	4	<1
Diarrhea	59	5	0	15	<1	0
Nausea	56	3	0	22	2	0
Weight decreased	48	4	0	15	0	0
Hypertension	42	7	0	6	0	0
Appetite decreased	40	6	0	19	0	0
Hair color changes	39	0	0	2	0	0
Vomiting	33	3	0	11	<1	0
Tumour pain	29	8	0	21	7	2
Dysgeusia	28	0	0	3	0	0
Headache	23	<1	0	8	0	0
Musculoskeletal pain	23	2	0	20	2	0
Myalgia	23	2	0	9	0	0
Gastrointestinal pain	23	3	0	9	4	0
Dyspnea	20	5	<1	17	5	<1
Exfoliative rash	18	<1	0	9	0	0
Cough	17	<1	0	12	<1	0
Peripheral edema	14	2	0	9	2	0
Alopecia	12	0	0	<1	0	0
Dizziness	11	<1	0	4	0	0
Skin disorder ^b	11	2	0	<1	0	0
Skin hypopigmentation	11	0	0	0	0	0
Stomatitis	11	<1	0	3	0	0
Chest pain	10	2	0	6	0	0

^a National Cancer Institute Common Terminology Criteria for Adverse Events, version 3.

^b 27 of the 28 cases of skin disorder were palmar-plantar erythrodysesthesia.

Other adverse reactions observed with an incidence <10% in STS patients treated with VOTRIENT include:

Blood and lymphatic system disorders: Thrombotic microangiopathy (<1%)

Cardiac disorders: cardiac dysfunction* (11%), myocardial dysfunction* (5%), QT Prolongation* (2%), myocardial infarction/ischemia* (2%)

Endocrine disorders: hypothyroidism* (8%).

Gastrointestinal disorders: dyspepsia (7%), abdominal pain upper (8%), dry mouth (7%), gastrointestinal perforations or fistula* (1%)

General disorders and administration site conditions: insomnia (9%), chills (5%)

Nervous system disorders: dysphonia (8%), vision blurred (5%), cerebral vascular accident (<1%)

Renal and urinary disorders: proteinuria* (1%), nephrotic syndrome (<1%)

Respiratory, thoracic and mediastinal disorders: Pneumothorax (3%)

Skin and subcutaneous disorders: dry skin (6%), nail disorder (5%)

Vascular disorders: pulmonary hemorrhage* (1%), epistaxis (8%), mouth hemorrhage* (3%), anal hemorrhage* (2%), venous thromboembolic events* (5%), gastrointestinal hemorrhage* (<1%), peritoneal hemorrhage (<1%), hematuria (<1%), cerebral hemorrhage*, including intracranial hemorrhage, subarachnoid hemorrhage (<1%), rectal hemorrhage (<1%), upper gastrointestinal hemorrhage (<1%)

*see WARNINGS AND PRECAUTIONS for additional information

Metastatic Renal Cell Carcinoma and Soft Tissue Sarcoma

Other adverse reactions observed more commonly in mRCC and STS patients treated with VOTRIENT with incidence more than 2% greater than placebo included:

Bradycardia: Based on heart rate measurement (<60 beats per minute), asymptomatic bradycardia was observed in 12% (33/280) patients treated with VOTRIENT and in 8% (11/144) of patients on the placebo arm in the randomized RCC trial. In the randomized trial of VOTRIENT for the treatment of STS, asymptomatic bradycardia was observed in 10% (24/238) of patients treated with VOTRIENT and in 2% (2/121) patients on the placebo arm. Symptomatic bradycardia has been identified rarely (<0.1%) based on a review of the pazopanib clinical trials safety database.

Diarrhea: Diarrhea occurred frequently and was predominantly mild to moderate in severity in both the RCC and STS clinical trials. Patients should be advised how to manage mild diarrhea and instructed to notify their healthcare provider if moderate to severe diarrhea occurs so appropriate management can be implemented to minimize this impact.

Amylase/Lipase Elevations: In a single-arm mRCC phase II clinical study, increases in amylase values were observed for 42/184 patients (23%) and increases in lipase values were observed for 48/181 patients (27%). Increased blood amylase as an adverse reaction was reported for 6/225 patients (3%), all were Grade 1 or Grade 2 in severity. Elevations in lipase as an adverse reaction were reported for 10 patients (4%) and were Grade 3 for 6 patients and Grade 4 for 1 patient. In clinical mRCC studies of VOTRIENT, clinical pancreatitis was observed in 4/586 patients (0.7%).

Pneumothorax: Two of 290 patients treated with VOTRIENT in the mRCC trial developed a pneumothorax. In a clinical trial of VOTRIENT for the treatment of STS, pneumothorax occurred in 8 of 240 patients (3%) treated with VOTRIENT and in no patients in the placebo group. All patients with pneumothorax in the VOTRIENT group had lung metastases at baseline.

Abnormal Hematologic and Clinical Chemistry Findings

Metastatic renal cell carcinoma

Table 3 presents the most common laboratory abnormalities occurring in $\geq 15\%$ of patients who received VOTRIENT in the pivotal mRCC studies, if they occurred more commonly in the VOTRIENT arm than in the placebo arm.

Table 3 Selected Laboratory Abnormalities in $\geq 15\%$ of mRCC Patients who Received VOTRIENT and More Common than in the Placebo Arm

Parameters	VOTRIENT (N=290)			Placebo (N=145)		
	All Grades * %	Grade 3 %	Grade 4 %	All Grades * %	Grade 3 %	Grade 4 %
Hematologic						
Leukopenia	37	0	0	6	0	0
Neutropenia	34	1	<1	6	0	0
Thrombocytopenia	32	<1	<1	5	0	<1
Lymphocytopenia	31	4	<1	24	1	0
Chemistry						
ALT increased	53	10	2	22	1	0
AST increased	53	7	<1	19	<1	0
Glucose increased	41	<1	0	33	1	0
Total bilirubin increased	36	3	<1	10	1	<1
Phosphorus decreased	34	4	0	11	0	0
Calcium decreased	33	1	1	26	1	<1
Sodium decreased	31	4	1	24	4	1
Potassium increased	27	4	<1	23	5	0
Creatinine increased	26	0	<1	25	<1	0
Magnesium decreased	26	<1	1	14	0	0
Glucose decreased	17	0	<1	3	0	0
TSH increased	31	N/A	N/A	5	N/A	N/A

* National Cancer Institute Common Terminology Criteria for Adverse Events, version 3. Grades 1-4.

Amylase/Lipase Elevations: In a single-arm mRCC phase II clinical study, increases in amylase values were observed for 42/184 patients (23%) and increases in lipase values were observed for 48/181 patients (27%).

Soft tissue sarcoma

Table 4 presents laboratory abnormalities occurring in $\geq 15\%$ of patients who received VOTRIENT in the pivotal STS study, if they occurred more commonly in the VOTRIENT arm than in the placebo arm.

Table 4 Selected Laboratory Abnormalities in $\geq 15\%$ of STS Patients who Received VOTRIENT and More Common than Placebo Arm (study VEG110727)

Parameters	VOTRIENT (N = 240)			Placebo (N = 123)		
	All Grades %	Grade 3 %	Grade 4 %	All Grades %	Grade 3 %	Grade 4 %
Haematological						
Leukopenia	44	1	0	15	0	0
Neutropenia	33	4	0	7	0	0
Thrombocytopenia	36	3	<1	6	0	0
Lymphocytopenia	43	10	0	36	9	2
Anaemia	27	5	2	23	<1	<1
Chemistry						
ALKP increased	32	3	0	23	<1	0
ALT increased	46	8	2	18	2	<1
AST increased	51	5	3	22	2	0
Albumin decreased	34	<1	0	21	0	0
Glucose increased	45	<1	0	35	2	0
Total Bilirubin increased	29	1	0	7	2	0
Sodium decreased	31	4	0	20	3	0
Potassium increased	16	1	0	11	0	0
TSH increased	34	N/A	N/A	2	N/A	N/A

Post-Market Adverse Drug Reactions

The following adverse reactions have been identified during post-approval use of VOTRIENT. This includes spontaneous case reports as well as adverse events from ongoing studies, clinical pharmacology studies and exploratory studies in unapproved indications.

Blood and lymphatic system disorders: Thrombotic microangiopathy (including TPP and HUS): (see WARNINGS and PRECAUTIONS) and Polycythemia.

Eye disorders: Retinal detachment/tear.

Hepatobiliary disorders: Gamma-glutamyl transpeptidase increased.

Infections and infestations: Infections (with or without neutropenia; see WARNINGS AND PRECAUTIONS).

Metabolism and nutrition disorders: Tumour lysis syndrome (including fatal cases), (see WARNINGS AND PRECAUTIONS).

Musculoskeletal and connective tissue disorders: Arthralgia, muscle spasms.

Posterior Reversible Encephalopathy Syndrome/Reversible Posterior Leukoencephalopathy Syndrome (PRES/RPLS): (see WARNINGS AND PRECAUTIONS).

Respiratory thoracic and mediastinal disorders: Interstitial lung disease/pneumonitis (see WARNINGS AND PRECAUTIONS).

Urogenital Fistula: Cases of urogenital fistulae were seen in a clinical trial of patients with a cancer type for which VOTRIENT is not approved. Most of the patients in this trial had received radiation therapy to the pelvis prior to entering the trial.

Vascular disorders: Artery dissection and artery aneurysm (including rupture) have been reported in association with VEGF TKIs, including VOTRIENT.

DRUG INTERACTIONS

Overview

Pazopanib is a substrate of CYP3A4 and the multidrug efflux pump P-glycoprotein (PgP). Therefore, absorption and subsequent elimination of pazopanib may be influenced by products that affect CYP3A4 and/or PgP. *In vitro* studies suggest that pazopanib is a substrate of breast cancer resistance protein (BCRP). Therefore, absorption and subsequent elimination of pazopanib may be influenced by products that affect BCRP.

Pazopanib is a potent *in vitro* inhibitor of proteins UDP glucuronosyltransferase 1 family, polypeptide A1 (UGT1A1) and the organic anion transporter polypeptide 1B1 (OATP1B1). Concomitant administration of pazopanib with UGT1A1 substrates (e.g. irinotecan) should be undertaken with caution. It cannot be excluded that pazopanib will affect the pharmacokinetics of substrates of OATP1B1 (eg. rosuvastatin).

Pazopanib is a weak inhibitor of CYP3A4, CYP2D6 and CYP2C8 based on results from clinical pharmacology studies.

Drug-Drug Interactions

Drugs that Inhibit or Induce Cytochrome P450 3A4 Enzymes

In vitro studies suggested that the oxidative metabolism of pazopanib in human liver microsomes is mediated primarily by CYP3A4, with minor contributions from CYP1A2 and CYP2C8. Therefore, inhibitors and inducers of CYP3A4 may alter the metabolism of pazopanib.

CYP3A4, P-gp, BCRP Inhibitors: Pazopanib is a substrate for CYP3A4, P-gp and BCRP. Coadministration of strong CYP3A4 inhibitors may increase pazopanib concentrations and drug toxicity. In a drug interaction study, concurrent administration of pazopanib (400 mg once daily) with the strong CYP3A4 and P-gp inhibitor, ketoconazole (400 mg once daily) for 5 consecutive days, resulted in a 66% and 45% increase in mean pazopanib $AUC_{(0-24)}$ and C_{max} , respectively, relative to administration of pazopanib alone (400 mg once daily for 7 days). In addition, more adverse events were observed when pazopanib was administered in combination with ketoconazole than when pazopanib was administered alone, which included cases of severe hypertension with systolic blood pressure of ~200 mmHg. As pazopanib C_{max} and $AUC_{(0-24)}$ increase in a less than dose proportional fashion with increasing dose over the range of 50 mg to 2000 mg, and as the 800 mg once daily dose of pazopanib alone was not included in this study, pharmacokinetic parameter comparisons across studies were made. These comparisons of pazopanib C_{max} (range of means 27.5 to 58.1 $\mu\text{g}/\text{ml}$) and $AUC_{(0-24)}$ (range of means 487 to 1040 $\mu\text{g}\cdot\text{h}/\text{ml}$) after administration of pazopanib 800 mg alone from three other studies and after administration of pazopanib 400 mg plus ketoconazole 400 mg (mean C_{max} 59.2 $\mu\text{g}/\text{ml}$, mean $AUC_{(0-24)}$ 1300 $\mu\text{g}\cdot\text{h}/\text{ml}$) in this study indicated that, in the presence of a strong CYP3A4 and P-gp inhibitor, a dose reduction to pazopanib 400 mg once daily may result in systemic exposure higher than that observed after administration of 800 mg pazopanib once daily alone. In addition, it should be noted that in a minority (25%) of patients the dose of 400 mg pazopanib once daily in the presence of ketoconazole resulted in systemic exposure greater than the highest systemic exposure observed in the other studies after administration of 800 mg pazopanib once daily alone.

Coadministration of strong CYP3A4 inhibitors (e.g. ketoconazole, itraconazole, clarithromycin, atazanavir, indinavir, nefazodone, nelfinavir, ritonavir, saquinavir, telithromycin, voriconazole) with VOTRIENT (pazopanib hydrochloride) should be avoided. If coadministration of a strong CYP3A4 inhibitor with VOTRIENT cannot be avoided, reduce the dose of VOTRIENT to 400 mg. In such cases there should be close attention to adverse drug reactions and the monitoring should begin earlier and frequency should be increased, especially for hypertension, as patients may have exposure greater than that of the 800 mg dose. Further dose reductions may be needed if adverse effects occur during therapy. Doses higher than 400 mg should not be used.

Administration of 1500 mg lapatinib, a substrate and weak inhibitor of CYP3A4, PgP and BCRP, with 800 mg pazopanib resulted in an approximately 50% to 60% increase in mean pazopanib AUC₍₀₋₂₄₎ and C_{max} compared to administration of 800 mg pazopanib alone. A Phase II study evaluating 1500 mg of lapatinib + 800 mg pazopanib was terminated early due to concerns over increased toxicity and/or mortality (see WARNINGS AND PRECAUTIONS, General, Combination with other systemic anti-cancer therapies). Coadministration of VOTRIENT with a CYP3A4, PgP or BCRP inhibitor may result in an increase in plasma pazopanib concentrations.

CYP3A4 Inducers: CYP3A4 inducers such as rifampin may decrease plasma pazopanib concentrations and should be avoided due to the potential for reduced effectiveness of the drug.

Drugs that Inhibit or Induce Transporters

Concomitant treatment with strong inhibitors of P-glycoprotein (P-gp) or inhibitors of both PgP and the breast cancer resistance protein (BCRP) should be avoided due to risk of increased exposure to pazopanib (see **CYP3A4 Inhibitors** above). Coadministration with inducers of P-gp should be avoided due to the risk of reduced effectiveness of the drug.

Effects of Pazopanib on CYP Substrates

In vitro studies with human liver microsomes showed that pazopanib inhibited CYP enzymes 1A2, 3A4, 2B6, 2C8, 2C9, 2C19, and 2E1. Potential induction of human CYP3A4 was demonstrated in an *in vitro* human PXR assay. Clinical pharmacology studies, using VOTRIENT 800 mg once daily, have demonstrated that VOTRIENT does not have a clinically relevant effect on the pharmacokinetics of caffeine (CYP1A2 probe substrate), warfarin (CYP2C9 probe substrate), or omeprazole (CYP2C19 probe substrate) in cancer patients. VOTRIENT resulted in an increase of approximately 30% in the mean AUC and C_{max} of midazolam (CYP3A4 probe substrate) and increases of 33% to 64% in the ratio of dextromethorphan to dextrorphan concentrations in the urine after oral administration of dextromethorphan (CYP2D6 probe substrate). Coadministration of VOTRIENT 800 mg once daily and paclitaxel 80 mg/m² (CYP3A4 and CYP2C8 substrate) once weekly resulted in a mean increase of 26% and 31% in paclitaxel AUC and C_{max}, respectively. Coadministration of VOTRIENT with agents with a narrow therapeutic window that are substrates for CYP3A4, CYP2C8 and CYP2D6 should be avoided.

Drugs that Raise Gastric pH

Solubility of pazopanib is pH-dependent and drugs that raise gastric pH may decrease pazopanib absorption. In a drug-drug interaction study, administration of esomeprazole in the evening and VOTRIENT in the morning for 5 days decreased the bioavailability of VOTRIENT by approximately 40% (AUC and C_{max}). Systemic exposures of three pazopanib metabolites were also decreased. The effect of VOTRIENT on esomeprazole (a substrate of CYP2C19 and CYP3A4) exposure was not investigated. Co-

administration of VOTRIENT with medicines that increase gastric pH including proton-pump inhibitors, H₂-receptor antagonists and short-acting antacids should be avoided.

Effects of Pazopanib on Transporters

In vitro studies also showed that pazopanib is a potent inhibitor of UGT1A1 and OATP1B1 with IC₅₀ of 1.2 and 0.79 µM, respectively. Pazopanib may increase concentrations of drugs primarily eliminated through UGT1A1 (e.g. irinotecan) and OATP1B1 (e.g. rosuvastatin).

Effect of concomitant use of VOTRIENT and Simvastatin

Concomitant use of VOTRIENT and simvastatin increases the risk of ALT elevations. Across monotherapy studies with VOTRIENT, ALT > 3xULN was reported in 126 / 895 (14 %) of patients who did not use statins, compared with 11/41 (27 %) of patients who had concomitant use of simvastatin (p = 0.038). If a patient receiving concomitant therapies develops ALT elevations, follow the recommendations for VOTRIENT dose modifications (see Hepatic in WARNINGS AND PRECAUTIONS) and discontinue simvastatin. Insufficient data are available to assess the risk of concomitant administration of alternative statins and VOTRIENT.

Drugs that affect the heart rate

Heart rate lowering drugs: VOTRIENT results in a decrease in heart rate (see WARNINGS AND PRECAUTIONS, Cardiovascular, ACTIONS AND CLINICAL PHARMACOLOGY, Cardiovascular). The concomitant use of VOTRIENT with other heart rate-lowering drugs, such as antiarrhythmics, beta blockers, non-dihydropyridine calcium channel blockers, cholinesterase inhibitors, and sphingosine-1 phosphate receptor modulators should be undertaken with caution.

QTc Prolonging Drugs: The concomitant use of VOTRIENT with QTc-prolonging drugs should be undertaken with caution because decreased heart rate can increase the risk of proarrhythmia in patients receiving these drugs. Drugs that have been associated with QTc interval prolongation and/or Torsade de Pointes include, but are not limited to, the examples in the following list. Chemical/pharmacological classes are listed if some, although not necessarily all class members have been implicated in QT/QTc prolongation and/or Torsade de Pointes.

- Antiarrhythmics (Class IA, e.g., quinidine, procainamide, disopyramide; Class III, e.g. amiodarone, sotalol, ibutilide, dronedarone; Class IC, e.g. flecainide, propafenone)
- Antipsychotics (e.g. chlorpromazine, pimozide, haloperidol, droperidol, ziprasidone)
- Antidepressants (e.g. amitriptyline, imipramine, maproptiline, fluoxetine, citalopram, venlafaxine)
- Opioids (e.g. methadone)

- Macrolide antibiotics (e.g. erythromycin, clarithromycin, telithromycin)
- Quinolone antibiotics (e.g. moxifloxacin, levofloxacin, ciprofloxacin)
- Antimalarials (e.g. quinine)
- Azole antifungals (e.g. ketoconazole, fluconazole, voriconazole)
- Gastrointestinal drugs (e.g. domperidone, 5HT3 antagonists such as granisetron, ondansetron, dolasetron)
- Beta 2-adrenoreceptor agonists (e.g. salmeterol, formoterol)
- Other tyrosine kinase inhibitors (e.g. sunitinib, nilotinib, lapatinib, sorafenib)
- Histone Deacetylase Inhibitors (e.g. vorinostat)
- Tacrolimus

The above list of potentially interacting drugs is not comprehensive. Current information sources should be consulted for newly-approved drugs that prolong the QT/QTc interval, as well as for older drugs for which these effects have recently been established.

Drug-Food Interactions

Grapefruit, grapefruit juice and other foods that are known to affect CYP3A4 and Pgp activity should be avoided during treatment.

Administration of VOTRIENT with a high-fat or low-fat meal results in an approximately 2-fold increase in AUC and C_{max} . Therefore, VOTRIENT should be administered at least 1 hour before or 2 hours after a meal.

Drug-Herb Interactions

Interactions with herbal products have not been established. St. John's wort (*Hypericum perforatum*) is an inducer of CYP3A4 that may increase the metabolism of pazopanib and decrease pazopanib blood levels.

Drug-Laboratory Interactions

Interactions between VOTRIENT and laboratory tests have not been studied.

DOSAGE AND ADMINISTRATION

The recommended dose of VOTRIENT for the treatment of mRCC and STS is 800 mg orally once daily.

VOTRIENT should be taken without food (at least one hour before or two hours after a meal) (see ACTION AND CLINICAL PHARMACOLOGY; Pharmacokinetics).

Dosing Considerations

Dose modification, either an increase or decrease in dose, should be in 200 mg increments in a stepwise fashion based on individual tolerability in order to manage adverse reactions. The dose of VOTRIENT should not exceed 800 mg.

Hepatic Impairment: VOTRIENT is not recommended in patients with baseline plasma bilirubin concentrations $>1.5 \times \text{ULN}$ (with direct bilirubin $>35\%$) and ALT elevations $>2 \times \text{ULN}$, or who have moderate or severe hepatic impairment (Child-Pugh B and C). No formal studies have been carried out in patients with mild hepatic impairment and caution is recommended in these patients (see ACTION AND CLINICAL PHARMACOLOGY; Special Populations and Conditions).

Renal Impairment: No dose adjustments are recommended for patients with mild or moderate renal impairment. Patients with $> 1 \text{ g}$ protein (24 h collection) at baseline were excluded from the pivotal clinical studies. VOTRIENT is not recommended for patients with severe renal impairment (see ACTION AND CLINICAL PHARMACOLOGY; Special Populations and Conditions).

Coadministration with strong CYP3A4 inhibitor: If coadministration of a strong CYP3A4 inhibitor with VOTRIENT cannot be avoided, reduce the dose of VOTRIENT to 400 mg. Further dose reductions may be needed if adverse effects occur during therapy. Doses higher than 400 mg should not be used (see DRUG INTERACTIONS; Drug-Drug Interactions; CYP3A4 Inhibitors).

Geriatrics: No alteration of dosage, dosing frequency or route of administration is required in patients over 65 years.

Missed Dose

If a dose is missed, VOTRIENT should not be taken if it is less than 12 hours until the next dose.

Administration

For oral use.

VOTRIENT should be taken whole with a glass of water and must not be broken or crushed (see ACTION AND CLINICAL PHARMACOLOGY; Pharmacokinetics).

OVERDOSAGE

For management of a suspected drug overdose, contact your regional Poison Control Centre.

Pazopanib doses up to 2000 mg have been evaluated in clinical trials. Grade 3 fatigue (dose limiting toxicity) and Grade 3 hypertension were each observed in 1 of 3 patients dosed at 2000 mg and 1000 mg daily, respectively.

Treatment of overdoses with VOTRIENT should consist of general supportive measures. There is no specific antidote for overdosage of VOTRIENT.

Hemodialysis is not expected to enhance the elimination of VOTRIENT because pazopanib is not significantly renally excreted and is highly bound to plasma proteins.

ACTION AND CLINICAL PHARMACOLOGY

Mechanism of Action

Pazopanib is an orally administered, small molecule, multi-target tyrosine kinase inhibitor (TKI). It is a potent inhibitor of vascular endothelial growth factor (VEGF) receptors (VEGFR)-1, -2, and -3, platelet-derived growth factor (PDGFR)- α and - β , and stem cell factor receptor (c-KIT), with IC_{50} values of 10, 30, 47, 71, 84 and 74 nM, respectively. In preclinical experiments, pazopanib dose-dependently inhibited ligand-induced auto-phosphorylation of VEGFR-2, c-Kit and PDGFR - β receptors in cells. *In vivo*, pazopanib inhibited VEGF-induced VEGFR-2 phosphorylation in mouse lungs, angiogenesis in various animal models, and the growth of multiple human tumour xenografts in mice.

Pharmacogenomics

In a pharmacogenetic meta-analysis of data from 31 clinical studies of pazopanib administered as either monotherapy or in combination with other agents, ALT > 3 X ULN occurred in 32% of HLA-B*57:01 allele carriers and in 19% of non-carriers, and ALT > 5 X ULN (NCI CTC Grade 3) occurred in 19% of HLA-B*57:01 allele carriers and in 10% of non-carriers. In this dataset, 133/2235 (6%) of the patients carried the HLA-B*57:01 allele (see Warnings and Precautions).

Pharmacokinetics

Table 5 Pazopanib Pharmacokinetic Parameters After Administration of 800 mg Pazopanib Once Daily for 17 Days (N=18)

	AUC(0-24) ($\mu\text{g}\cdot\text{h}/\text{mL}$)	C_{max} ($\mu\text{g}/\text{mL}$)	t_{max}¹ (h)
Geometric mean	1,037	58.1	3.13
CVb%	34.3	33.3	1.0-8.0

¹ t_{max} reported as median and range

Results from a population pharmacokinetic analysis suggest that the coefficients of variation for inter-subject variability in pazopanib oral clearance and volume of distribution were 52.3% and 67.1%, respectively.

Absorption: Pazopanib is absorbed orally with median time to achieve peak concentrations of 2.0 to 4.0 hours after the dose. Daily dosing results in 1.23- to 4-fold increase in AUC. Bioavailability differences accounts for non-linear kinetics between 200 to 800 mg (400 mg is approximately 1.4 X more bioavailable than 800 mg). No consistent increases in AUC and C_{max} were observed when the oral dose was increased above 800 mg (plateau was reached). The oral bioavailability of pazopanib reflects absorption that is limited by solubility and reaches saturation at doses above 800 mg once daily.

Systemic exposure to pazopanib is increased when administered with food. Administration of pazopanib with a high-fat or low-fat meal results in an approximately 2-fold increase in AUC and C_{max}. Therefore, pazopanib should be administered at least 1 hour before or 2 hours after a meal (see DOSAGE AND ADMINISTRATION).

Administration of a single pazopanib 400 mg crushed tablet increased AUC₍₀₋₇₂₎ by 46% and C_{max} by approximately 2 fold and decreased t_{max} by approximately 1.5 hours compared to administration of the whole tablet. These results indicate that the bioavailability and the rate of pazopanib oral absorption are increased after administration of the crushed tablet relative to administration of the whole tablet. Therefore, due to this potential for increased exposure, tablets should not be crushed (see DOSAGE AND ADMINISTRATION).

Distribution: Binding of pazopanib to human plasma protein *in vivo* was greater than 99% with no concentration dependence over the range of 10-100 $\mu\text{g}/\text{ml}$. *In vitro* studies suggest that pazopanib is a substrate for P-glycoprotein (PgP) and breast cancer resistant protein (BCRP).

Metabolism: Results from *in vitro* studies demonstrated that the metabolism of pazopanib is mediated primarily by CYP3A4, with minor contributions from CYP1A2 and CYP2C8.

Excretion: Pazopanib is eliminated slowly with mean half-life of 30.9 hours after administration of the recommended dose of 800 mg. Most of the oral dose (60-70%) is not metabolized and excreted unmodified in the feces. Approximately 7-15% of the administered dose is recovered as metabolites in the feces, with renal elimination accounting for <4% of the administered dose.

Special Populations and Conditions

Hepatic Insufficiency: The safety and pharmacokinetics of VOTRIENT in patients with pre-existing hepatic impairment have not been fully established (see WARNINGS AND PRECAUTIONS). Pharmacokinetic data from patients with normal hepatic function (n = 12) and moderate (n = 7) hepatic impairment indicate that pazopanib clearance was decreased by approximately 50 % in those with moderate hepatic impairment [total bilirubin > 1.5 to 3 X Upper Limit of Normal (ULN)]. However, patients with moderate hepatic impairment experienced dose-limiting toxicity at the 400 mg dose. There are no data in patients with severe hepatic impairment (total bilirubin > 3 X ULN). There are no data to support dosing recommendation in patients with mild hepatic impairment (see WARNINGS AND PRECAUTIONS).

Renal Insufficiency: Patients with renal cell cancer and mild/moderate renal impairment (creatinine clearance \geq 30mL/min) were included in clinical studies for VOTRIENT.

Renal impairment is not expected to have a clinically relevant effect on pazopanib pharmacokinetics given the low renal excretion of pazopanib and metabolites (see *Pharmacokinetics - Excretion*). In a population pharmacokinetic analysis using 408 patients with various cancers, creatinine clearance (30-150 mL/min) did not influence clearance of pazopanib. Therefore, renal impairment is not expected to influence pazopanib exposure, and dose adjustment is not necessary. There is no experience of VOTRIENT in patients with severe renal impairment or in patients undergoing peritoneal dialysis or haemodialysis; therefore, use of VOTRIENT is not recommended in these patients.

Pharmacodynamics

Cardiovascular: A randomised, double-blind, placebo-controlled, parallel group, repeat dose study was performed to evaluate the effect of VOTRIENT on electrocardiographic parameters in patients with solid tumours. Evaluable patients received placebo (n=32) or VOTRIENT (n=33) administered as a dose of 800 mg for 7 days, then as a 1600 mg dose with food on the eighth day. This achieved plasma levels that were approximately 1.3 to 1.4 times higher than those associated with the recommended 800 mg once daily dose. Serial ECG data were collected for 8 h post-dosing on day 8. VOTRIENT caused a decrease in heart rate at all time points on days 8 that reached mean -14.5 (90% CI -17.8, -11.2) bpm at 8 h (the last time point tested).

The PR interval was significantly increased at 6 and 8 h post-dosing, reaching a mean difference versus placebo of 7.26 (90% CI 2.64, 11.88) ms at 8 h post-dosing.

VOTRIENT was associated with statistically significant increases in systolic and diastolic blood pressure on day 8 of treatment. The maximum observed difference versus placebo in systolic blood pressure was mean 16.48 (90% CI 11.04, 21.93) mmHg at 8 h post-dosing, whilst the maximum observed difference versus placebo in diastolic blood pressure was mean 11.83 (90% CI 9.11, 14.54) mmHg, also at 8 h. Antihypertensive medications were used by 41% of patients in this trial.

STORAGE AND STABILITY

Store between 15-30°C.

DOSAGE FORMS, COMPOSITION AND PACKAGING

The 200 mg tablets of VOTRIENT (pazopanib as pazopanib hydrochloride) are modified capsule shaped, grey, film coated with GS JT debossed on one side and are available in bottles of 120 tablets.

The 400 mg* tablets of VOTRIENT are modified capsule shaped, yellow, film coated with GS UHL debossed on one side and are available in bottles of 30 tablets and 60 tablets.

The tablet core contains the following excipients; magnesium stearate, microcrystalline cellulose, povidone (K30) and sodium starch glycollate. The tablet coating contains the following excipients; hypromellose, iron oxide black (E172 – 200mg tablet), iron oxide yellow (E172 – 400mg tablet), macrogol, polysorbate 80 and titanium dioxide (E171).

*VOTRIENT 400 mg tablets not available in Canada.

PART II: SCIENTIFIC INFORMATION

PHARMACEUTICAL INFORMATION

Drug Substance

- Common name: pazopanib hydrochloride
- Chemical name: 5-[[4-[(2,3-Dimethyl-2H-indazol-6-yl)(methyl)amino]pyrimidin-2-yl]amino]-2-methylbenzenesulfonamide monohydrochloride
- Molecular formula: $C_{21}H_{23}N_7O_2S \cdot HCl$
- Molecular mass: 473.99 g/mol (437.53 g/mol free base)
- Structural formula:

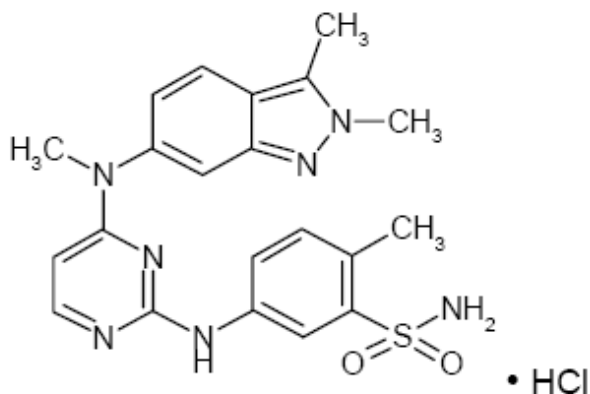

Physicochemical properties: Pazopanib hydrochloride is a white to slightly yellow solid. It is very slightly soluble at pH 1 and practically insoluble above pH 4 in aqueous media.

CLINICAL TRIALS

Metastatic Renal Cell Carcinoma

The safety and efficacy of VOTRIENT (pazopanib hydrochloride) in renal cell carcinoma (RCC) were evaluated in a randomized, double-blind, placebo-controlled phase III multi-centre study.

The primary objective of the study was to evaluate and compare the two treatment arms for progression-free survival (PFS) and the principle secondary endpoint is overall survival (OS). The other objectives were to evaluate the overall response rate, duration of response and quality of life measures.

Trial Design

Patients with metastatic RCC (mRCC) were randomized (2:1) to receive VOTRIENT 800 mg once daily, or placebo with best supportive care, following stratification by ECOG performance status (0 vs. 1); prior nephrectomy (yes vs. no); and prior therapy (no prior systemic therapy vs. one prior cytokine-based therapy).

Disease assessments were performed every 6 weeks until Week 24, and every 8 weeks thereafter until disease progression. Tumour lesion selection, classification and tumour response evaluation were performed using RECIST. All imaging scans were evaluated by an independent review committee (IRC) of radiologists.

After documented radiological progression, patients could be unblinded by the investigator; those randomised to placebo were then able to receive open-label VOTRIENT 800 mg/day.

Study Demographics and Baseline Characteristics

Table 6 below summarizes the patient demographics in the VOTRIENT pivotal clinical trial.

From the total of 435 patients in this study, 233 patients were treatment naïve and 202 were second line patients who received one prior IL-2 or INF-based therapy. The performance status (ECOG) was similar between the VOTRIENT and placebo groups (ECOG 0: 42% vs. 41%, ECOG 1: 58% vs. 59%). All patients had metastatic disease at screening with either clear cell histology or predominantly clear cell histology. Approximately half of all patients had 3 or more organs involved in their disease and most patients had the lung (74%), and/or lymph nodes (54%) as a metastatic location for disease at baseline.

A similar proportion of patients in each arm were treatment-naïve and cytokine-pre-treated (53% and 47% in VOTRIENT arm, 54% and 46% in placebo arm). In the cytokine-pre-treated subgroup, the majority (75%) had received interferon based treatment.

Similar proportions of patients in each arm had prior nephrectomy (89% and 88% in the VOTRIENT and placebo arms, respectively) and/or prior radiotherapy (22% and 15% in the VOTRIENT and placebo arms, respectively).

Table 6 Summary of patient demographics in pivotal clinical trial of VOTRIENT in mRCC (ITT Population), (VEG105192)

Characteristics	VOTRIENT N=290	Placebo N=145	Total N=435
Age, Years			
Median (range)	59 (28-85)	60 (25-81)	59 (25-85)
Gender, %			
Female	32	25	29
Male	68	75	71
Age Group, %			
<65 years	68	59	65
≥65 years	32	41	35
Race, %			
White	87	84	86
Asian	12	16	14
Black	<1	0	<1
Other	<1	0	<1
Performance Status, %			
ECOG 0	42	41	42
ECOG 1	58	59	58
Prior Treatment, %			
Treatment naïve	53	54	54
Cytokine-pre-treated	47	46	47

Study results

The primary analysis of the primary endpoint PFS is based on disease assessment by independent radiological review in the entire study population (treatment-naïve and cytokine pre-treated). OS data were not mature at the time of the final PFS analysis.

A clinically and statistically significant improvement in PFS was observed in the VOTRIENT treated arm compared to the placebo-treated arm with a hazard ratio of 0.46 (95% CI, 0.34, 0.62, $p < 0.0000001$), indicating a 54% reduction in risk of progression or death with more than doubling of the median PFS (9.2 vs. 4.2 months).

Overall efficacy results by independent review committee are presented in Table 7.

Table 7 Overall Efficacy Results in mRCC by Independent Review Committee (VEG105192)

Endpoints/ Study population	VOTRIENT	Placebo	HR (95% CI)	P value (two-sided)
PFS	Median (months)			
Overall* (ITT)	N=290 9.2	N=145 4.2	0.46 (0.34, 0.62)	<0.0000001
Treatment-naïve	N=155 11.1	N=78 2.8	0.40 (0.27, 0.60) ^a	<0.0000001
Cytokine pre-treated	N=135 7.4	N=67 4.2	0.54 (0.35, 0.84) ^a	<0.001
Response rate	% (95% CI)			
Overall	N=290 30 (25.1, 35.6)	N=145 3 (0.5, 6.4)	-	<0.001

* Treatment naïve and cytokine pre-treated populations; CI: confidence interval; PFS: progression free survival; ITT: intent-to-treat.

a. Unadjusted estimate.

No significant treatment-related difference in interim overall survival was noted.

The Response Rate (RR), defined as the percentage of patients who achieved either a confirmed complete response or partial response according to RECIST criteria, was significantly higher in the VOTRIENT arm compared with the placebo arm. By independent review, the difference in RR was 26.9% (95% CI: 20.8, 33.0, $p < 0.001$) and by investigator review was 29.3% (95% CI: 22.5, 36.1, $p < 0.001$). The independent- and investigator-evaluated best confirmed responses by RECIST were similar for both treatment arms.

For patients who responded to treatment, the median duration of response was 58.7 weeks as per independent review.

The median overall survival (OS) data at the protocol specified final survival analysis were 22.9 months and 20.5 months [HR = 0.91 (95 % CI: 0.71, 1.16; $p = 0.224$)] for patients randomized to the VOTRIENT and placebo arms, respectively. The OS results are subject to potential bias as 54 % of patients in the placebo arm also received VOTRIENT in the extension part of this study following disease progression. Sixty-six percent of placebo patients received post-study therapy compared to 30 % of VOTRIENT patients.

Kaplan-Meier curves for progression-free survival by Independent Review Committee assessment for the overall (ITT) population are presented in Figure 1.

Figure 1 Kaplan-Meier Curve for Progression-Free Survival by Independent Assessment for the Overall mRCC Population (Treatment-Naïve and Cytokine Pre-Treated Populations); (VEG105192)

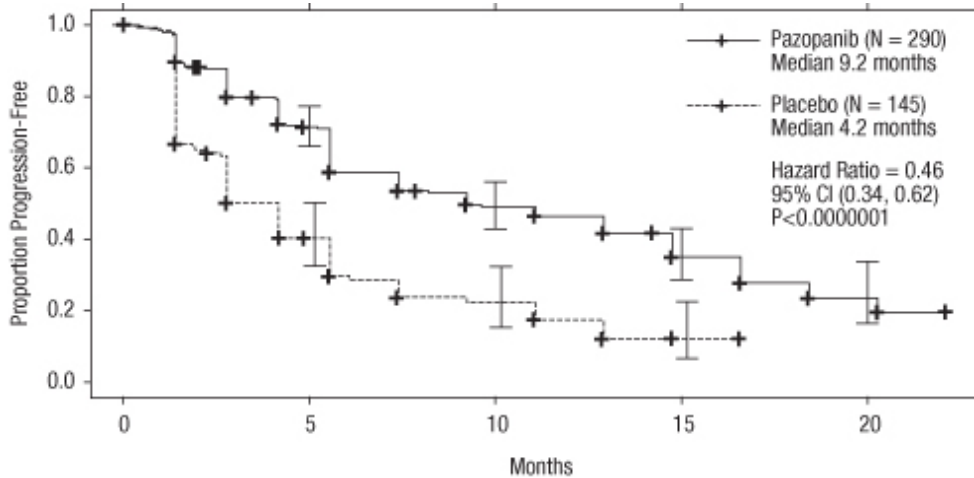

Additional subgroup analysis demonstrated that the treatment effect of VOTRIENT on PFS in all subgroups analyzed, including analysis by treatment-naïve population (Table 7), cytokine pre-treated population (Table 7), gender, age, ECOG PS, and the Memorial Sloan-Kettering Cancer Centre (MSKCC) prognostic risk category, was consistent with the primary analysis.

In the pivotal study, the QoL assessments were based on blinded self-reported global scores from two protocol-specified questionnaires, EORTC QLQ-C30 and EuroQoL EQ-5D. Analysis was based on patients who continued on therapy in both arms, prior to progression. The assessments showed no difference between treatment with VOTRIENT or placebo ($p > 0.05$).

Soft Tissue Sarcoma

The safety and efficacy of VOTRIENT in STS were evaluated in a randomized, double-blind, placebo-controlled multi-centre study (VEG110727).

The primary objective of the study was to evaluate and compare the two treatment arms for progression-free survival (PFS), based on the ITT population, and the principle secondary endpoint was overall survival (OS).

Trial Design

Adult patients with selective subtypes of advanced Soft Tissue Sarcoma (STS) who had received prior chemotherapy for metastatic disease or who had progressed within 12 months after (neo)adjuvant therapy were eligible to enter the trial. Patients were required to have disease progression on or after, or be intolerant to, an anthracycline-based regimen. Patients who have been previously treated with inhibitors of angiogenesis

and/or VEGF or VEGFR-targeting agents were excluded. Prior to study enrollment, all patients had to have confirmed disease progression.

The following tumour types were eligible: Fibroblastic (adult fibrosarcoma, myxofibrosarcoma, sclerosing epithelioid fibrosarcoma, malignant solitary fibrous tumours), so-called fibrohistiocytic [pleomorphic malignant fibrous histiocytoma (MFH), giant cell MFH, inflammatory MFH], leiomyosarcoma, malignant glomus tumours, skeletal muscles (pleomorphic and alveolar rhabdomyosarcoma), vascular (epithelioid hemangioendothelioma, angiosarcoma), uncertain differentiation (synovial, epithelioid, alveolar soft part, clear cell, desmoplastic small round cell, extra-renal rhabdoid, malignant mesenchymoma, PEComa, intimal sarcoma; excluding chondrosarcoma, Ewing tumours / primitive neuroectodermal tumours), malignant peripheral nerve sheath tumours, undifferentiated soft tissue sarcomas not otherwise specified (NOS) and other types of sarcoma (not listed as ineligible).

The following tumour types were not eligible: Adipocytic sarcoma (all subtypes), all rhabdomyosarcoma that were not alveolar or pleomorphic, chondrosarcoma, osteosarcoma, Ewing tumours/ primitive neuroectodermal tumours, GIST, dermatofibromatosis sarcoma protuberans, inflammatory myofibroblastic sarcoma, malignant mesothelioma and mixed mesodermal tumours of the uterus.

Patients with adipocytic sarcoma were excluded because activity (PFS at week12) observed with VOTRIENT in a phase II study (VEG20002) in these tumours was indeterminant.

Prior to randomization, eligible subjects were stratified by the factors of WHO performance status (WHO PS) (0 or 1) at baseline and the number of lines of prior systemic therapy for advanced disease (0 or 1 vs. 2+). Patients were randomized (2:1) to receive VOTRIENT 800 mg once daily or placebo.

Treatment activity was assessed at 4 week intervals during the first 12 weeks of treatment and every 8 weeks thereafter until progression or the start of a new anti-cancer therapy; objective response and progression were defined according to the RECIST v1.0. Blinded independent radiological review was used for the primary analysis. Each patient was to be followed until death or withdrawal of consent.

Study demographics and baseline characteristics

A total of 369 patients were randomized in the study and formed the ITT population.

Table 8 below summarizes the patient demographics and baseline characteristics in the VOTRIENT STS pivotal clinical trial.

Table 8 Summary of patient demographics and characteristics in pivotal clinical trial of VOTRIENT in STS: ITT Population (study VEG110727)

Characteristics	VOTRIENT N=246	Placebo N=123	Total N=369
Age, Years			
Median (range)	56.0 (18,78)	51.0 (20,83)	55 (18,83)
Gender, n (%)			
Female	147 (60)	69 (56)	216 (59)
Male	99 (40)	54 (44)	153 (41)
Race, %			
White	71	74	72
Asian	23	22	22
Other	6	4	6
STS Tumour Subtype, n (%)			
Leiomyosarcoma	109(44)	49(40)	158(43)
Synovial sarcoma	25(10)	13(11)	38(10)
Other STS*	112(46)	61(49)	173(47)
Tumour Grade**, n (%)			
Low (grade 1)	33 (13)	11 (9)	44(12)
Intermediate (grade 2)	70 (28)	29 (24)	99(27)
High (grade 3)	72 (29)	44 (36)	116(31)
Performance Status, n (%)			
WHO PS 0	118(48)	60(49)	178(48)
WHO PS 1	128(52)	63(51)	191(52)
Prior Systemic Treatment for Advanced Disease, n(%)			
0 lines	14(6)	13(11)	27(7)
1 lines	96(39)	39(32)	135(37)
2 lines	85(35)	44(36)	129(35)
3 lines	35(14)	18(15)	53(14)
4 lines	16(7)	9(7)	25(7)
Prior Adjuvant Therapy	43 (17)	26 (21)	69 (19)
Prior Neoadjuvant Therapy	31 (13)	19 (15)	50 (14)
Prior Maintenance Therapy	10 (4)	4 (3)	14 (4)
Prior Chemotherapy	246 (100)	123 (100)	369 (100)
Doxorubicin	242 (98)	121 (98)	363 (98)
Ifosfamide	164 (67)	93 (76)	257 (70)
Docetaxel	69 (28)	35 (28)	104 (28)
Gemcitabine	85 (35)	42 (34)	127 (34)
Trabectedin	38 (15)	22 (18)	60 (16)
mTOR inhibitors	11 (4)	3 (2)	14 (4)
Other	105 (43)	53 (43)	158 (43)

* “Other STS” included fibroblastic type (N=32), so-called fibrohistiocytic tumours (N=32), tumours of uncertain differentiation (N=33), undifferentiated sarcomas NOS (N=20), MPNST (N=12), vascular tumours (N=7), skeletal muscle/rhabdomyosarcoma (N=2), adipocytic tumours (N=1), pericytic tumours (N=1), chondro-osseous tumours (N=1) and “other” tumour types (N=32) of sarcomas not listed as ineligible.

**In patients with central pathology grading.

Study Results

The initial analysis of the primary endpoint PFS was based on disease assessment by independent radiological review in the entire ITT study population.

The median duration of follow-up of patients (defined as date of randomization to date of last contact or death) was similar for both treatment arms [9.36 months for placebo (range 0.69 to 23.0 months) and 10.04 months for VOTRIENT (range 0.2 to 24.3 months)].

A clinically and statistically significant improvement in PFS was observed in the VOTRIENT treated arm compared to placebo-treated arm, with a hazard ratio of 0.35 (95% CI, 0.26, 0.48, $p < 0.001$), indicating a 65% reduction in risk of progression or death, more than doubling the median PFS (20.0 vs 7.0 weeks).

Disease assessment occurred at 4 week intervals through week 12 and at 8 week intervals thereafter. Since the VOTRIENT median PFS was 20 weeks it is possible that if a disease assessment had been done at 16 weeks the median PFS would have been earlier.

Overall efficacy results as independently assessed are presented in Table 9.

Table 9 Overall efficacy results in STS by independent assessment (study VEG110727)

	VOTRIENT	Placebo	HR (95% CI)	P value (one-sided)
Overall ITT Population	N=246	N=123		
PFS				
Overall ITT population Median PFS (weeks)	20.0	7.0	0.35 (0.26, 0.48)	< 0.001
Leiomyosarcoma Median PFS (weeks)	N = 109 20.1	N = 49 8.1	0.37 (0.23, 0.60)	< 0.001
Synovial sarcoma Median PFS (weeks)	N = 25 17.9	N = 13 4.1	0.43 (0.19, 0.98)	0.005
‘Other’ STS Median PFS (weeks)	N = 112 20.1	N = 61 4.3	0.39 (0.25, 0.60)	< 0.001
Overall survival (OS)*				
Overall ITT population Median OS (months)	12.6	10.7	0.87 (0.67, 1.12)	p=0.256
Leiomyosarcoma Median OS (months)	N=109 16.7	N=49 14.1	0.84 (0.56, 1.26)	p=0.363
Synovial sarcoma Median OS (months)	N=25 8.7	N=13 21.6	1.62 (0.79, 3.33)	p=0.115
‘Other’ STS Median OS (months)	N=112 10.3	N=61 9.5	0.84 (0.59, 1.21)	p=0.325
Response Rate (CR + PR) % (95 % CI)	4 (2.3, 7.9)	0 (0.0, 3.0)	-	-
Duration of response Median (weeks) (95 % CI)	38.9 (16.7, 40.0)	-	-	-

HR = Hazard ratio; ITT = Intent to treat; PFS = Progression-free survival; CR = Complete Response; PR = Partial Response; NS = not significant.

* Overall survival for the respective STS histological subgroups (leiomyosarcoma, synovial sarcoma and “Other” STS) should be interpreted with caution due to the small number of subjects and wide confidence intervals

Similar to the assessments by independent radiology review, a clinically meaningful and statistically significant improvement in PFS based on investigator assessments was observed in the VOTRIENT arm compared with the placebo arm (HR: 0.39; 95 % CI, 0.30 to 0.52, p <0.001).

A greater percentage of patients on the placebo arm (69%) than the VOTRIENT arm (53%) received systemic anti-cancer therapy (chemotherapy and/or targeted therapy) excluding surgery and radiotherapy post discontinuation of study drug.

Figure 2 Kaplan-Meier Curve for Progression-Free Survival in STS by Independent Assessment for the Overall Population (VEG110727)

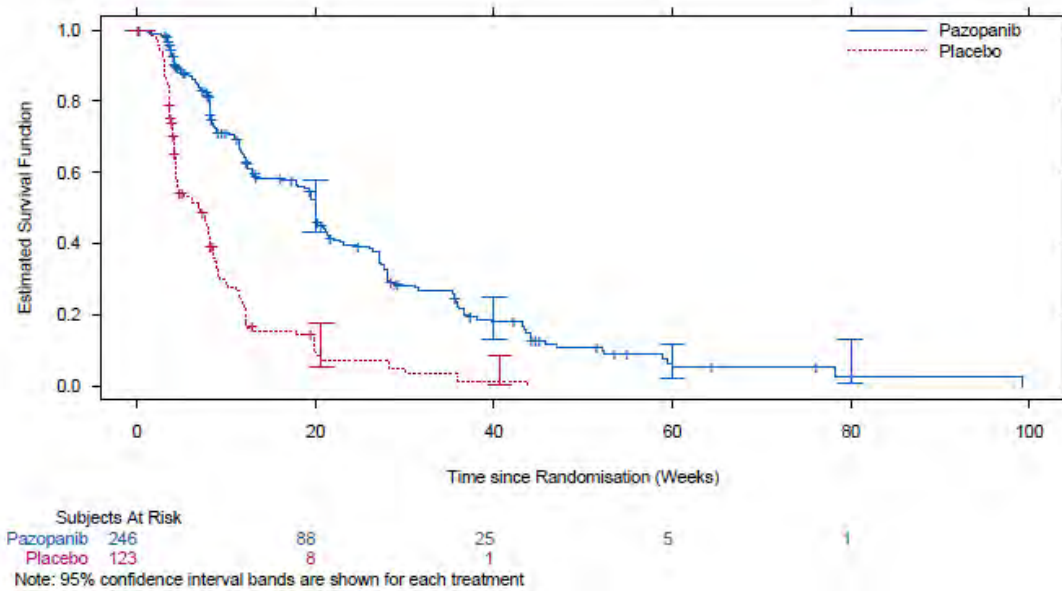

No significant difference in OS was observed between the two treatment arms at the final OS analysis performed after 76% (280/369) of the events had occurred. At the protocol-specified final analysis of OS, the median OS was 12.6 months for patients randomized to VOTRIENT and 10.7 months for the placebo arm [HR = 0.87 (95% CI:0.67, 1.12)].

DETAILED PHARMACOLOGY

Refer to PART I, ACTION AND CLINICAL PHARMACOLOGY.

TOXICOLOGY

Carcinogenesis, Mutagenesis, Impairment of Fertility, Developmental Toxicity

Mice given 1000 mg/kg/day (approximately 1.5 times the human clinical exposure based on AUC) for 13 weeks had proliferative lesions noted in the liver including eosinophilic foci in 2 females and a single case of adenoma in another female.

In a 2-year, oral gavage carcinogenicity study in mice, pazopanib was administered once daily at doses of 0, 10, 30, and 100 mg/kg/day. Neoplastic changes were limited to an increase in hepatic adenomas in females given 100 mg/kg/day (approximately 1.3 times the human clinical exposure based on AUC).

In a 2-year, oral gavage carcinogenicity study in rats, pazopanib was administered once daily at doses of 0, 3, 10, and 30 mg/kg/day. Neoplastic changes were present in the duodenum. Duodenal adenocarcinoma occurred in females at ≥ 10 mg/kg/day, and in males at 30 mg/kg/day, and Brunner's gland hyperplasia was observed in males at 30 mg/kg/day (≥ 0.3 , 0.3 and 0.3 times human clinical exposure based on AUC, respectively).

Pazopanib did not cause genetic damage when tested in genotoxicity assays (Ames assay, human peripheral lymphocyte chromosome aberration assay and rat *in vivo* micronucleus assay).

In female rats, reduced fertility was present at 300 mg/kg (approximately 0.8 times the human clinical exposure based on AUC). Increased pre- and post-implantation loss and early resorptions were noted at dosages ≥ 10 mg/kg/day (approximately 0.2 times the human clinical exposure based on AUC). Decreased corpora lutea were observed in monkeys given 500 mg/kg/day for up to 34 weeks, in mice given ≥ 300 mg/kg/day for 13 weeks and ovarian atrophy was noted in rats given 300 mg/kg/day for 26 weeks (approximately equal to, 0.6, 1.4 and 0.9 times the human clinical exposure based on AUC, respectively).

Pazopanib did not affect mating or fertility in male rats. However, there were reductions in sperm production rates, sperm motility, and epididymal and testicular sperm concentrations observed at ≥ 100 mg/kg/day (approximately 0.5 times the human clinical exposure based on AUC) following 15 weeks of dosing. Following 26 weeks of dosing, there were decreased testicular and epididymal weights, atrophy and degeneration of the testes with aspermia, hypospermia and cribiform change in the epididymis of male rats given doses ≥ 30 mg/kg/day (approximately 0.4 times the human clinical exposure based on AUC).

Pazopanib produced foetal teratogenic effects (including cardiovascular malformations and delayed ossification), reduced foetal body weight, and embryo lethality in rats at a dose level of ≥ 3 mg/kg/day (approximately 0.1 times the human clinical exposure based on AUC). In rabbits, maternal toxicity (body weight loss, reduced food consumption, and abortion) were observed at doses ≥ 30 mg/kg/day (approximately 0.007 times the human clinical exposure based on AUC), while foetal weight was reduced at doses ≥ 3 mg/kg/day (see WARNINGS AND PRECAUTIONS; Special Populations).

Animal Toxicology and/or Pharmacology

In toxicology studies in rats, there were effects in a variety of tissues (bone, teeth, bone marrow, nail beds, reproductive organs, hematological tissues, kidney, adrenal glands, lymph node, pituitary, and pancreas) consistent with VEGFR inhibition and/or disruption of VEGF signalling pathways with some effects occurring at doses of 3 mg/kg/day (approximately 0.1 times the human clinical exposure based on AUC).

In repeat-dose toxicology studies in rats including 4-week, 13-week and 26-week administration, toxicities in bone, teeth and nail beds were observed at doses

≥ 3 mg/kg/day (approximately 0.1 times the human clinical exposure based on AUC). Doses of 300 mg/kg/day (approximately 0.8 times the human clinical exposure based on AUC) were not tolerated in 13- and 26-week studies with rats. Body weight loss and morbidity were observed at these doses. Hypertrophy of epiphyseal growth plates, nail abnormalities (including broken, overgrown, or absent nails) and tooth abnormalities in growing incisor teeth (including excessively long, brittle, broken and missing teeth, and dentine and enamel degeneration and thinning) were observed in rats at ≥ 30 mg/kg/day (approximately 0.35 times the human clinical exposure based on AUC) at 26 weeks, with the onset of tooth and nail bed alterations noted clinically after 4 to 6 weeks (see PART I, INDICATIONS and CLINICAL USE, Pediatrics).

Hepatic effects included mild elevations of liver transaminases in rodents and bilirubin elevations in monkeys without associated histopathology at doses that produced systemic exposures approximately 0.1 and 0.6 times the human clinical exposure, respectively. Vascular pathology was observed in intrahepatic branches of the hepatic artery and arterioles near the liver hilus in rats administered 500mg/kg/day for 8 days.

To determine the tolerability and toxicokinetics of pazopanib in juvenile rats a dose-ranging study was conducted. Pazopanib was administered from Day 9 through Day 35 post-partum (pp) at 0.3, 3, 30, 300 and 1000 mg/kg/day and from Day 21 through Day 35 pp at 30, 300 and 1000 mg/kg/day. Differences in tolerability were noted. Specifically, when dosing began on Day 21 pp (which approximates a human paediatric age of 2 years), dose levels up to 1000 mg/kg (up to 0.84x the clinical exposure based on AUC in adults) were tolerated. The only finding consisted of marked decreases in body weight gain from 300 mg/kg. In contrast, when dosing was initiated on Day 9 pp, dose levels ≥ 30 mg/kg (up to 0.4x the clinical exposure based on AUC in adults) were not tolerated due to deaths starting on Day 13 pp. At 300 and 1000 mg/kg, all animals were euthanized or found dead after the first week of dosing. Dose levels of 0.3 and 3 mg/kg (less than 0.01x and 0.1x the clinical exposure based on AUC in adults) were well tolerated from Day 9 pp until Day 35 pp.

To explore the noted difference in sensitivity, an investigative study was conducted wherein juvenile rats aged 9 to 14 days post-partum were dosed at 10 and 100 mg/kg/day (equal to approximately 0.16x and 0.43x human clinical exposure based on AUC in adults, respectively). A dose level of 10 mg/kg was tolerated but resulted in a 60-70% decrease in body weight gain. At 100 mg/kg, deaths and a lack of body weight gain was observed. At both doses, profound effects on organ growth and maturation were observed and included decreased absolute kidney weight (up to -35% and -48% at 10 and 100 mg/kg, respectively), liver weight (up to -39% and -54% at 10 and 100 mg/kg, respectively), heart weight (up to -43% and -53% at 10 and 100 mg/kg, respectively), brain weight (up to -15% and -21% at 10 and 100 mg/kg, respectively) and lung weight (up to -36% and -49% at 10 and 100 mg/kg, respectively). At 100 mg/kg decreased cell proliferation and increased cell apoptosis was also observed in various organs. Histologically, glomerulopathy was noted at both dose levels with renal endothelial cells being a primary target. Degenerative changes occurred as early as 24 hours after the first dose which progressed to necrosis and loss of endothelium, thinning of glomerular basement membranes, and subsequent effects on mesangial cells and podocytes. These

findings suggest that pazopanib interferes with VEGF-dependent glomerular maturation as well as organ growth and development of kidney, heart, liver, and lung in pre-weanling juvenile rats.

A third juvenile toxicity study was conducted to determine the potential effects of pazopanib on viability, growth and development when administered to juvenile rats from Day 21 to 62 pp at 10, 30 and 300 mg/kg/day (less than 1.0x human clinical exposure based on AUC in adults). Two female rats were terminated early due to excessive body weight loss and rats were administered 100 mg/kg for the remainder of the study. In contrast with juvenile animals dosed with pazopanib from Day 9 to Day 21 pp, administration of pazopanib from Day 21 to Day 62 pp was associated with toxicological findings that were similar to those noted in adult rats and include decreased body weight gain (≥ 10 mg/kg), broken and/or loose incisor teeth (≥ 30 mg/kg), alterations in the femur and tibia (growth plate hypertrophy, thinning of cortical bone, partial physal closure and tibial fracture at ≥ 30 mg/kg). Dose-dependent decreases in femoral length occurred at all dose levels and were proportional with body weight effects, suggesting an effect on overall growth of the juvenile animals. Other affected tissues include the trachea, adrenal, pancreas, stomach, duodenum, lymph node, male mammary gland and reproductive organs.

SAFETY PHARMACOLOGY

In safety pharmacology studies, there were no pazopanib-related central and peripheral nervous system, respiratory or cardiovascular effects in rats or monkeys given single oral doses of up to 300 mg/kg or 500 mg/kg, respectively.

A single intravenous dose of 3.75 mg/kg to conscious male cynomolgus monkeys produced a mild, reversible decrease in heart rate (11 to 45 beats/min or 7 to 26%), but had no effect on arterial pressures or body temperature, did not produce any abnormal changes in ECG intervals and there was no evidence of drug-related ECG waveform abnormalities or arrhythmias. The C_{max} and AUC (55 $\mu\text{g/mL}$ and 41 $\mu\text{g.h/mL}$, respectively) in this study were within the C_{max} and AUC range seen in the oral cardiovascular study.

In a hERG assay, pazopanib was tested at concentrations of up to 4.137 μM . When the current was expressed as % control and compared to vehicle, there was a very mild effect on hERG tail current but inhibition was not of sufficient magnitude to allow estimation of the IC_{25} , IC_{50} or IC_{75} values.

There were also no treatment-related effects on action potential duration or other action potential parameters when dog Purkinje fibers were incubated with up to 80 nM pazopanib (concentration limited by compound solubility).

REFERENCES

1. Sternberg CN, Davis IA, Mardiak J, et al. Pazopanib in Locally Advanced or Metastatic Renal Cell Carcinoma: Results of a Randomized Phase III Trial. *JCO*. 2010;28(6): 1061-1068.
2. Harris PA, Bloor A, Cheung M, et al. Discovery of 5-[[4-[(2,3-dimethyl-2H-indazol-6-yl)methylamino]-2-pyrimidinyl]amino]-2-methyl-benzene-sulfonamide (Pazopanib), a novel and potent vascular endothelial growth factor receptor inhibitor. *J Med Chem*. 2008;51(15):4632-4640.
3. Hurwitz HI, Dowlati A, Saini S et al. Phase I Trial of Pazopanib in Patients with Advanced Cancer. *Clin Cancer Res* 2009;15(12): 4220-4227.
4. Hutson TE, Bukowski RM. A phase II study of GW786034 using a randomized discontinuation design in patients with locally recurrent or metastatic clear-cell renal cell carcinoma. *Clin Genitourin Cancer*. 2006;4(4):296-298.
5. Karaman MW, Herrgard S, Treiber DK, Gallant P, Atteridge CE, Campbell BT, Chan KW, Ciceri P, Davis MI, Edeen PT, Faraoni R, Floyd M, Hunt JP, Lockhart DJ, Milanov ZV, Morrison MJ, Pallares G, Patel HK, Pritchard S, Wodicka LM, Zarrinkar PP. A quantitative analysis of kinase inhibitor selectivity. *Nat Biotechnol*. 2008 Jan;26(1):127-32.
6. Kumar R, Knick VB, Rudolph SK, et al. Pharmacokinetic-pharmacodynamic correlation from mouse to human with pazopanib, a multikinase angiogenesis inhibitor with potent antitumor and antiangiogenic activity. *Mol Cancer Ther*. 2007;6(7):2012-2021.
7. Sleijfer S, Ray-Coquard I, Papai Z, et al. Pazopanib, a Multikinase Angiogenesis Inhibitor, in Patients With Relapsed or Refractory Advanced Soft Tissue Sarcoma: A Phase II Study From the European Organisation for Research and Treatment of Cancer-Soft Tissue and Bone Sarcoma Group (EORTC Study 62043). *J Clin Oncol*. 2009.
8. Van der Graaf WTA, Blay JY, Chawla SP, et al. Pazopanib for metastatic soft-tissue sarcoma (PALETTE): a randomised, double-blind, placebo-controlled phase 3 trial. *Lancet* 2012; 379(9829):1854-1856.

PART III: CONSUMER INFORMATION

PrVOTRIENT® Pazopanib Tablets

This leaflet is part III of a three-part "Product Monograph" published when VOTRIENT® was approved for sale in Canada and is designed specifically for Consumers. This leaflet is a summary and will not tell you everything about VOTRIENT. Contact your doctor or pharmacist if you have any questions about the drug.

ABOUT THIS MEDICATION

What the medication is used for:

VOTRIENT is used in the treatment of:

Metastatic kidney cancer (when cancer cells have spread from the kidney to other parts of the body).

Selective subtypes of advanced soft tissue sarcoma in patients who have received prior chemotherapy. Soft tissue sarcoma is a type of cancer that occurs in muscles, blood vessels or other tissues that support, surround and protect the organs.

VOTRIENT is shown to slow tumour growth, however, it is not known whether VOTRIENT prolongs overall survival or improves the quality of life of patients.

What it does:

VOTRIENT prevents the activity of a special group of proteins which are known to be involved in the growth and spread of cancer cells.

When it should not be used:

VOTRIENT must not be used if you are allergic to pazopanib hydrochloride, or any of the other ingredients in VOTRIENT (see What the important nonmedicinal ingredients are).

VOTRIENT must not be used in children under two years of age.

What the medicinal ingredient is:

The active ingredient is pazopanib hydrochloride.

What the important nonmedicinal ingredients are:

The other ingredients are hypromellose, macrogol 400, magnesium stearate, microcrystalline cellulose, povidone (K30), polysorbate 80, sodium starch glycollate, titanium dioxide (E171), iron oxide black (E172) and iron oxide

yellow (E172).

What dosage forms it comes in:

VOTRIENT is available as tablets. Each film coated tablet contains either 200 mg or 400 mg* of pazopanib hydrochloride. The 200 mg tablets of VOTRIENT are modified capsule shaped, grey, film coated with GS JT debossed on one side and are available in bottles of 120 tablets.

The 400 mg* tablets are modified capsule shaped, yellow, film coated with GS UHL debossed on one side and are available in bottles of 30 tablets or 60 tablets.

*VOTRIENT 400 mg tablets not available in Canada

WARNINGS AND PRECAUTIONS

Serious Warnings and Precautions

VOTRIENT should be prescribed and managed by a doctor experienced in the use of cancer drugs.

VOTRIENT is not recommended for patients with moderate or severe liver impairment (reduced function).

Serious side effects with the use of VOTRIENT may include the following:

- Liver toxicity
- High blood pressure
- Effect on the electrical activity of the heart (QT/QTc prolongation)
- Heart becomes less effective at pumping blood (cardiac dysfunction)
- Blood clots (arterial thromboembolic or venous thrombotic events and thrombotic microangiopathy)
- Bleeding
- Gastrointestinal perforation (a hole that develops through the wall of the stomach, small intestine or large bowel) and fistula (an abnormal connection between parts of the digestive tract)
- Reversible swelling in the rear part of the brain that can be associated with high blood pressure and can lead to headache, loss of speech or vision, abnormal drowsiness, confusion and/or seizure (Posterior Reversible Encephalopathy Syndrome or Reversible Posterior Leukoencephalopathy Syndrome)
- Tumor Lysis syndrome (a complication due to the breakdown of cancer cells)

Safety and efficacy of VOTRIENT have not been established in children less than 18 years of age. VOTRIENT must not be used in children under two years of age.

BEFORE you use VOTRIENT talk to your doctor or pharmacist:

- if you have or had heart disease, heart failure or heart attack
- if you have or have had a heart rhythm disorder such as irregular heartbeat, prolongation of the QT interval or any risk factors for Torsade de Pointes (dangerous rapid fluttering of the heart) such as diabetes, low potassium, magnesium or calcium levels, or a history of low heart rate, fainting, or loss of consciousness
- if you have problems with your blood pressure and its complications, including separation of the layers of the arterial wall (Artery Dissection)
- if you have liver disease
- if you have problems with bleeding
- if you have gastrointestinal problems
- if you have or had a blood clot in a vein or in a lung
- if you have had prior collapse of a lung
- if you have a kidney problem
- if you have thyroid problems
- if you are going to have a surgical or dental procedure, or if you have had either recently

While you are taking VOTRIENT your doctor will take blood samples to check for any liver problems. You should report any signs or symptoms of liver injury including jaundice (yellowing of whites of eyes or skin), unusual darkening of the urine, anorexia (loss of appetite), nausea, fatigue, right upper abdominal discomfort and vomiting. Your doctor will also take urine samples to check for any kidney problems. You will also have your blood pressure checked. Your doctor will periodically record your electrocardiogram (ECG) to check your heart's electrical conduction.

Your doctor will also check on any recent surgical or dental procedures to see if you are healing properly.

Some patients treated with VOTRIENT have experienced Tumour Lysis Syndrome (including fatal cases). This is a serious condition that can happen with the sudden death of cancer cells. Your healthcare professional will monitor you for signs of Tumour Lysis Syndrome.

Use a reliable method of contraception to avoid becoming pregnant while you're taking VOTRIENT and for up to 8 weeks after you stop treatment with VOTRIENT. If you are pregnant or think you could be, talk to your doctor about the risks and benefits to you and your baby while taking

VOTRIENT. Your doctor may recommend that you don't take VOTRIENT while you are pregnant.

Male patients (including those who have had vasectomies) with sexual partners who are pregnant, possibly pregnant, or who could become pregnant should use condoms during sexual intercourse while taking VOTRIENT and for at least 2 weeks after the last dose of drug.

Breastfeeding is not recommended during treatment with VOTRIENT. Ask your doctor for advice.

INTERACTIONS WITH THIS MEDICATION

Tell your doctor or pharmacist if you are taking, or have recently taken any other medicines including any medicines you bought without a prescription. This includes herbal medicines.

Some medicines may affect the way VOTRIENT works or VOTRIENT may affect how other medicines work. These include:

- clarithromycin, ketoconazole, itraconazole, telithromycin, voriconazole (used to treat infections)
- atazanavir, indinavir, nelfinavir, ritonavir, saquinavir (used to treat HIV)
- dextromethorphan (used in cough medicines)
- simvastatin and possibly other statins (used to treat high cholesterol levels)
- medicines that reduce stomach acid (e.g. esomeprazole, ranitidine, magnesium hydroxide)

Also, the following list includes some, but not all, of the drugs that may interact with VOTRIENT to affect the electrical activity of your heart:

- antiarrhythmics (drugs that stabilize the heart rhythm function, such as quinidine, procainamide, amiodarone, sotalol, etc.)
- antidepressants (mood disorder drugs)
- antipsychotics (drugs used to stabilize thinking and behaviour)
- opioids (e.g. methadone)
- macrolide antibiotics (such as erythromycin, clarithromycin)
- fluoroquinolone antibiotics (such as moxifloxacin, levofloxacin, ciprofloxacin)
- antifungals (such as fluconazole, voriconazole)
- antimalarials (e.g. quinine)
- anti-nauseants (e.g. granisetron, ondansetron, dolasetron)
- anti-asthmatics (e.g. salmeterol, formoterol)
- tacrolimus (used after organ transplant to prevent

- rejection)
- certain anticancer treatments (e.g. sunitinib, nilotinib, lapatinib, sorafenib, vorinostat)

VOTRIENT is affected by food intake (see PROPER USE OF THIS MEDICATION). You should not drink grapefruit juice or eat grapefruit while you are being treated with VOTRIENT as this may increase the chance of side effects.

PROPER USE OF THIS MEDICATION

Always take VOTRIENT exactly as your doctor has told you. Check with your doctor or pharmacist if you are not sure.

Usual dose:

The usual dose is 800 mg VOTRIENT, taken once a day.

Do not take more than 800 mg VOTRIENT a day.

Swallow the tablets whole with water, one after the other, at about the same time each day. Do not break or crush the tablets as it affects the way the medicine is absorbed and may increase the chance of side effects.

It is important that you take VOTRIENT either at least one hour before or at least two hours after food.

Depending on your response to treatment, your doctor may recommend adjusting your dose or temporarily stopping your treatment.

Overdose:

If you have accidentally taken more VOTRIENT tablets than you should, contact your doctor, or poison control centre, or go to the emergency room of the nearest hospital even if there are no symptoms.

Missed Dose:

If you forget to take VOTRIENT, do not take a double dose to make up for a missed dose. Take the next dose at the scheduled time.

SIDE EFFECTS AND WHAT TO DO ABOUT THEM

Like all medicines, VOTRIENT can cause side effects including:

- feeling or being sick (nausea or vomiting)
- loss of appetite
- stomach pain or discomfort

- weight loss
- problems with taste
- sore mouth, mouth ulcers or sores
- indigestion
- flatulence
- headache
- loss of strength
- lack of energy
- weakness
- difficulty sleeping
- dizziness
- changes in hair colour
- skin rash
- unusual hair loss or thinning
- loss of skin pigment
- dry skin
- nail disorder
- unusual prickling or crawling sensations on the skin
- excessive sweating
- hoarseness
- nosebleeds
- cough
- shortness of breath
- swelling of hands, ankles or feet
- muscle pain
- muscle spasms
- pain in the bones, muscles, ligaments, joints and tendons
- slow heart rate
- tumour pain
- increase in some substances (enzymes) produced by the liver
- under-active thyroid gland
- chills
- urinary tract infection
- blood in the urine
- painful urination
- infections, with or without changes in white blood cells (cells that fight infection)

VOTRIENT can cause abnormal blood and urine test results. Your doctor will decide when to perform blood and urine tests and will interpret the results.

If you get side effects, tell your doctor or pharmacist if any of the side effects listed becomes severe or troublesome, or if you notice any side effects not listed in this leaflet.

SERIOUS SIDE EFFECTS, HOW OFTEN THEY HAPPEN AND WHAT TO DO ABOUT THEM

Symptom / effect	Talk with your doctor or pharmacist		Stop taking drug and call your doctor or pharmacist
	Only if severe	In all cases	
Very common			
Palmar-plantar erythrodysesthesia syndrome (skin reaction also known as hand-foot syndrome): pain, tingling, swelling or redness, thick calluses and blisters on the palms of the hands or soles of the feet	✓		
Chest pain		✓	
Common			
QT-prolongation (changes in the heart's electrical conduction): irregular heartbeat, fainting, loss of consciousness, seizures		✓	
Myocardial infarction (heart attack, the supply of blood to the heart is suddenly blocked): pressure, tightness, pain, or a squeezing or aching sensation in chest or arms			✓
Pneumothorax (sudden collapse of a lung): sudden chest pain and shortness of breath			✓
Diarrhea: severe, 3 or more loose or liquid bowel movements in a day; may be accompanied by fever		✓	
Liver problems and/or liver failure: yellowing of the skin and eyeballs (jaundice), dark urine, pain in your right abdomen, abdominal swelling, nausea, vomiting, a general sense of feeling unwell (malaise), disorientation			✓

SERIOUS SIDE EFFECTS, HOW OFTEN THEY HAPPEN AND WHAT TO DO ABOUT THEM

Symptom / effect	Talk with your doctor or pharmacist		Stop taking drug and call your doctor or pharmacist
	Only if severe	In all cases	
or confusion or sleepiness			
Hypertension (increased blood pressure): can be sudden and severe, may be life-threatening; headache, stronger and possibly faster heartbeat		✓	
Transient ischemic attack (mini-stroke, temporary reduction in blood supply to the brain): numbness or weakness on one side of the body, difficulty speaking, dizziness, loss of balance. Symptoms can last from a few minutes to several hours.		✓	
Angina (reduction of blood supply to the heart): discomfort in the shoulder, arm, back, throat, jaw or teeth; pain or pressure in the chest		✓	
Deep vein thrombosis or pulmonary embolism (blood clots in the veins of the arms, legs or lungs): chest pain, shortness of breath, leg pain, swelling of the legs/feet		✓	
Heart failure (decreased amount of blood pumped out of the heart): shortness of breath, fatigue, swollen feet and ankles		✓	
Hemorrhage (severe bleeding from the esophagus, stomach, intestine or anus): vomiting blood, passing blood with or in the stools or black stools			✓
Uncommon			

SERIOUS SIDE EFFECTS, HOW OFTEN THEY HAPPEN AND WHAT TO DO ABOUT THEM

Symptom / effect	Talk with your doctor or pharmacist		Stop taking drug and call your doctor or pharmacist
	Only if severe	In all cases	
Pulmonary haemorrhage (severe bleeding in lung): coughing up blood			✓
Cerebral haemorrhage (severe bleeding in brain): a sudden severe headache, seizures, weakness in an arm or leg, lethargy, changes in vision, difficulty speaking or understanding speech, loss of coordination, loss of balance, loss of consciousness			✓
Torsade de Pointes (a dangerous rapid fluttering of the heart): heart palpitations, dizziness, nausea, cold sweats, chest pain, shortness of breath, rapid pulse or low blood pressure			✓
Heart problems including irregular heartbeat: dizziness, palpitations, cold sweats, chest pain, shortness of breath, rapid pulse or low blood pressure		✓	
Stroke (poor blood flow to the brain): sudden numbness or weakness of your arm, leg or face, especially if only on one side of the body; difficulty speaking sudden difficulty in walking or loss of balance or coordination			✓
Thrombotic microangiopathy [TMA], including thrombotic thrombocytopenic			✓

SERIOUS SIDE EFFECTS, HOW OFTEN THEY HAPPEN AND WHAT TO DO ABOUT THEM

Symptom / effect	Talk with your doctor or pharmacist		Stop taking drug and call your doctor or pharmacist
	Only if severe	In all cases	
purpura [TTP] and hemolytic uremic syndrome [HUS] (blood clots accompanied by a decrease in red blood cells and cells involved in clotting): bruising under the skin, bleeding of the nose or gums, less urine, blood in the urine			
Gastrointestinal perforation (hole in digestive tract): abdominal pain or tenderness, bloating or a feeling of fullness (distention) in abdomen			✓
Fistula (abnormal connection between parts of the digestive tract): diarrhea, rectal bleeding, weight loss, dehydration			✓
Pancreatitis (inflammation of the pancreas): abdominal pain that lasts and gets worse when you lie down, nausea, vomiting			✓
Retinal detachment or tear (separation or tear of the lining of the back part of the eye): trouble seeing, blurry or impaired vision			✓
Very rare			
Artery dissection (sudden severe pain in the back, chest or abdomen)			✓
Artery aneurysm (a bulge in the wall of any artery including in the chest, arms, legs, heart, and brain): symptoms will differ by the site. They can be cough, coughing up blood, strong pain high in your			✓

SERIOUS SIDE EFFECTS, HOW OFTEN THEY HAPPEN AND WHAT TO DO ABOUT THEM

Symptom / effect	Talk with your doctor or pharmacist		Stop taking drug and call your doctor or pharmacist
	Only if severe	In all cases	
neck or in your back when you didn't hurt yourself, problems swallowing, hoarse voice, unusual pulsing in your chest or abdomen			
Unknown Frequency			
Interstitial lung disease (a form of lung scarring or inflammation, can have a fatal outcome in some cases): cough, shortness of breath, difficulty breathing, fever		✓	
Posterior Reversible Encephalopathy Syndrome or Reversible Posterior Leukoencephalopathy Syndrome (reversible swelling in the rear part of the brain): headaches, seizures, loss of speech or vision, high blood pressure, abnormal drowsiness, confusion, seizure			✓
Tumour lysis syndrome (the sudden, rapid death of cancer cells due to the treatment): nausea, shortness of breath, irregular heartbeat, heart rhythm disturbances, lack of urination, clouding of urine, muscle spasms or twitching, tiredness and/or joint pain, severe muscle weakness, and seizures. Metabolic disorders (kidney failure, abnormal heartbeat) and abnormal blood tests due to rapid breakdown of cancer cells.			✓

This is not a complete list of side effects. For any unexpected effects while taking VOTRIENT, contact your doctor or

pharmacist.

HOW TO STORE IT

Keep out of the reach and sight of children. Do not use VOTRIENT after the expiry date.

Store between 15°C - 30°C.

If you have any unwanted tablets do not put them in waste water or household rubbish. Ask your pharmacist how to dispose of tablets you do not need. This will help to protect the environment.

REPORTING SIDE EFFECTS

You can report any suspected side effects associated with the use of health products to Health Canada by:

- Visiting the Web page on Adverse Reaction Reporting (<http://www.hc-sc.gc.ca/dhp-mps/medeff/report-declaration/index-eng.php>) for information on how to report online, by mail or by fax; or
- Calling toll-free at 1-866-234-2345.

NOTE: Contact your health professional if you need information about how to manage your side effects. The Canada Vigilance Program does not provide medical advice.

MORE INFORMATION

This document plus the full product monograph, prepared for health professionals can be found at:

<http://www.novartis.ca> or by contacting the sponsor,

Novartis Pharmaceuticals Canada Inc.
385 Bouchard Blvd.
Dorval, Quebec
H9S 1A9
1-800-363-8883

This leaflet was prepared by Novartis Pharmaceuticals Canada Inc.

Last revised: February 28, 2020

VOTRIENT is a registered trademark

HIGHLIGHTS OF PRESCRIBING INFORMATION

These highlights do not include all the information needed to use VOTRIENT safely and effectively. See full prescribing information for VOTRIENT.

VOTRIENT® (pazopanib) tablets, for oral use
Initial U.S. Approval: 2009

WARNING: HEPATOTOXICITY

See full prescribing information for complete boxed warning.

Severe and fatal hepatotoxicity has been observed in clinical trials. Monitor hepatic function and interrupt, reduce, or discontinue dosing as recommended. (5.1)

RECENT MAJOR CHANGES

Indications and Usage (1.1, 1.2)	8/2020
Dosage and Administration (2.1, 2.2, 2.3, 2.4)	8/2020
Warnings and Precautions (5.1-5.6, 5.8-5.14)	8/2020
Warnings and Precautions, Tumor Lysis Syndrome (5.15)	6/2020

INDICATIONS AND USAGE

VOTRIENT is a kinase inhibitor indicated for the treatment of adults with:

- advanced renal cell carcinoma (RCC). (1.1)
- advanced soft tissue sarcoma (STS) who have received prior chemotherapy. (1.2)

Limitations of Use: The efficacy of VOTRIENT for the treatment of patients with adipocytic soft tissue sarcoma or gastrointestinal stromal tumors has not been demonstrated.

DOSAGE AND ADMINISTRATION

- **Recommended Dosage:** 800 mg orally once daily without food (at least 1 hour before or 2 hours after a meal). (2.1)
- **Moderate Hepatic Impairment:** 200 mg orally once daily. (2.2)

DOSAGE FORMS AND STRENGTHS

Tablets: 200 mg (3)

CONTRAINDICATIONS

None. (4)

WARNINGS AND PRECAUTIONS

- **Hepatic Toxicity:** Severe and fatal hepatotoxicity has occurred. Monitor liver tests at baseline, regularly during treatment and as clinically indicated. Withhold VOTRIENT and resume at reduced dose with continued weekly monitoring for 8 weeks, or permanently discontinue with weekly monitoring until resolution based on severity of hepatotoxicity. (2.2, 5.1)
- **QT Prolongation and Torsades de Pointes:** Monitor patients who are at significant risk of developing QT interval prolongation. Monitor electrocardiograms (ECGs) and electrolytes at baseline and as clinically indicated. Correct hypokalemia, hypomagnesemia, and hypocalcemia prior to initiating VOTRIENT and during treatment. (2.2, 5.2)
- **Cardiac Dysfunction:** Cardiac dysfunction, including decreased left ventricular ejection fraction (LVEF) and congestive heart failure, have occurred. Monitor blood pressure and manage as appropriate. Monitor for clinical signs or symptoms of congestive heart failure. Conduct baseline and periodic evaluation of LVEF in patients at risk of cardiac dysfunction. Withhold or permanently discontinue VOTRIENT based on severity of cardiac dysfunction. (2.2, 5.3)
- **Hemorrhagic Events:** Fatal hemorrhagic events have occurred. VOTRIENT has not been studied in patients who have a history of hemoptysis, cerebral hemorrhage, or clinically significant gastrointestinal hemorrhage in the past 6 months. Withhold VOTRIENT and resume at reduced dose or permanently discontinue based on severity of hemorrhagic events. (2.2, 5.4)
- **Arterial Thromboembolic Events:** Arterial thromboembolic events have been observed and can be fatal. VOTRIENT has not been studied in patients who have had an arterial thromboembolic event within the previous 6 months. Permanently discontinue VOTRIENT in case of an arterial thromboembolic event. (2.2, 5.5)
- **Venous Thromboembolic Events:** Venous thromboembolic events (VTEs) have been observed, including fatal pulmonary emboli (PE). Monitor for signs and symptoms of VTE and PE. Withhold VOTRIENT and then resume at same dose or permanently discontinue based on severity of venous thromboembolic event. (2.2, 5.6)
- **Thrombotic Microangiopathy:** Thrombotic microangiopathy (TMA), including thrombotic thrombocytopenic purpura (TTP) and hemolytic uremic syndrome (HUS), has been observed. Permanently discontinue VOTRIENT if TMA occurs. (2.2, 5.7)
- **Gastrointestinal Perforation and Fistula:** Fatal perforation events have occurred. Monitor for signs and symptoms of gastrointestinal perforation or fistula. Withhold VOTRIENT in case of Grade 2 or 3 gastrointestinal fistula and resume based on medical judgement. Permanently discontinue VOTRIENT in case of gastrointestinal perforation or Grade 4 gastrointestinal

fistula. (2.2, 5.8)

- **Interstitial Lung Disease /Pneumonitis:** Can be fatal. Monitor patients for pulmonary symptoms. Permanently discontinue VOTRIENT in patients who develop interstitial lung disease (ILD) or pneumonitis. (2.2, 5.9)
- **Posterior Reversible Encephalopathy Syndrome:** Can be fatal. Permanently discontinue VOTRIENT in patients who develop posterior reversible encephalopathy syndrome (PRES). (2.2, 5.10)
- **Hypertension:** Hypertension, including hypertensive crisis, has been observed. Do not initiate VOTRIENT in patients with uncontrolled hypertension. Optimize blood pressure prior to initiating VOTRIENT. Monitor blood pressure as clinically indicated and initiate and adjust antihypertensive therapy as appropriate. Withhold and then dose reduce VOTRIENT or permanently discontinue based on severity of hypertension. (2.2, 5.11)
- **Risk of Impaired Wound Healing:** Withhold VOTRIENT for at least 1 week prior to elective surgery. Do not administer for at least 2 weeks following major surgery and until adequate wound healing. The safety of resumption of VOTRIENT after resolution of wound healing complications has not been established. (5.12)
- **Hypothyroidism:** Monitor thyroid tests at baseline, during treatment and as clinically indicated and manage hypothyroidism as appropriate. (5.13)
- **Proteinuria:** Perform baseline and periodic urinalysis during treatment with follow up measurement of 24-hour urine protein as clinically indicated. Withhold VOTRIENT then resume at a reduced dose or permanently discontinue based on severity of proteinuria. Permanently discontinue in patients with nephrotic syndrome. (2.2, 5.14)
- **Tumor Lysis Syndrome:** Cases of tumor lysis syndrome (TLS) (some fatal) have been reported in patients with RCC and STS. Closely monitor patients at risk and treat as clinically indicated. (5.15)
- **Infection:** Serious infections (with or without neutropenia), some with fatal outcome, have been reported. Monitor for signs and symptoms of infection. Institute appropriate anti-infective therapy promptly. Consider interruption or discontinuation of VOTRIENT. (5.16)
- **Embryo-Fetal Toxicity:** Can cause fetal harm. Advise females of reproductive potential of the potential risk to the fetus and patients to use effective contraception. (5.19, 8.1, 8.3)

ADVERSE REACTIONS

- The most common adverse reactions in patients with RCC ($\geq 20\%$) are diarrhea, hypertension, hair color changes (depigmentation), nausea, anorexia, and vomiting. (6.1)
- The most common adverse reactions in patients with STS ($\geq 20\%$) are fatigue, diarrhea, nausea, decreased weight, hypertension, decreased appetite, vomiting, tumor pain, hair color changes, musculoskeletal pain, headache, dysgeusia, dyspnea and skin hypopigmentation. (6.1)

To report SUSPECTED ADVERSE REACTIONS, contact Novartis Pharmaceuticals Corporation at 1-888-669-6682 or FDA at 1-800-FDA-1088 or www.fda.gov/medwatch.

DRUG INTERACTIONS

- **Strong CYP3A4 Inhibitors:** Avoid coadministration of VOTRIENT with strong CYP3A4 inhibitors. If coadministration cannot be avoided, reduce the dose of VOTRIENT. (2.4, 7.1)
- **Strong CYP3A4 Inducers:** Consider an alternate concomitant medication with no or minimal enzyme induction potential. VOTRIENT is not recommended if chronic use of strong CYP3A4 inducers cannot be avoided. (2.4, 7.1)
- **CYP Substrates:** Coadministration of VOTRIENT with agents with narrow therapeutic windows that are metabolized by CYP3A4, CYP2D6, or CYP2C8 is not recommended. (7.2)
- **Concomitant Use With Simvastatin:** Concomitant use of VOTRIENT with simvastatin increases the risk of alanine aminotransferase (ALT) elevations. Increase to weekly monitoring of liver function as recommended. Withhold VOTRIENT and resume at reduced dose, or permanently discontinue based on severity of hepatotoxicity. (7.3)
- **Concomitant Use With Gastric Acid-Reducing Agents:** Avoid concomitant use of VOTRIENT with gastric acid-reducing agents. Consider short-acting antacids in place of proton pump inhibitors (PPIs) and H2-receptor antagonists. Separate antacid and pazopanib dosing by several hours. (2.4, 7.4)

USE IN SPECIFIC POPULATIONS

- **Lactation:** Advise not to breastfeed. (8.2)

See 17 for PATIENT COUNSELING INFORMATION and Medication Guide.

Revised: 8/2020

FULL PRESCRIBING INFORMATION: CONTENTS***WARNING: HEPATOTOXICITY****1 INDICATIONS AND USAGE**

- 1.1 Renal Cell Carcinoma
- 1.2 Soft Tissue Sarcoma

2 DOSAGE AND ADMINISTRATION

- 2.1 Recommended Dosage
- 2.2 Dosage Modifications for Adverse Reactions
- 2.3 Dosage Modifications for Hepatic Impairment
- 2.4 Dosage Modifications for Drug Interactions

3 DOSAGE FORMS AND STRENGTHS**4 CONTRAINDICATIONS****5 WARNINGS AND PRECAUTIONS**

- 5.1 Hepatic Toxicity
- 5.2 QT Prolongation and Torsades de Pointes
- 5.3 Cardiac Dysfunction
- 5.4 Hemorrhagic Events
- 5.5 Arterial Thromboembolic Events
- 5.6 Venous Thromboembolic Events
- 5.7 Thrombotic Microangiopathy
- 5.8 Gastrointestinal Perforation and Fistula
- 5.9 Interstitial Lung Disease/Pneumonitis
- 5.10 Posterior Reversible Encephalopathy Syndrome
- 5.11 Hypertension
- 5.12 Risk of Impaired Wound Healing
- 5.13 Hypothyroidism
- 5.14 Proteinuria
- 5.15 Tumor Lysis Syndrome
- 5.16 Infection
- 5.17 Increased Toxicity With Other Cancer Therapy
- 5.18 Increased Toxicity in Developing Organs
- 5.19 Embryo-Fetal Toxicity

6 ADVERSE REACTIONS

- 6.1 Clinical Trials Experience
- 6.2 Postmarketing Experience

7 DRUG INTERACTIONS

- 7.1 Effect of Other Drugs on VOTRIENT
- 7.2 Effects of VOTRIENT on Other Drugs
- 7.3 Concomitant Use With Simvastatin
- 7.4 Concomitant Use With Gastric Acid-Reducing Agents
- 7.5 Drugs That Prolong the QT Interval

8 USE IN SPECIFIC POPULATIONS

- 8.1 Pregnancy
- 8.2 Lactation
- 8.3 Females and Males of Reproductive Potential
- 8.4 Pediatric Use
- 8.5 Geriatric Use
- 8.6 Renal Impairment
- 8.7 Hepatic Impairment

10 OVERDOSAGE**11 DESCRIPTION****12 CLINICAL PHARMACOLOGY**

- 12.1 Mechanism of Action
- 12.2 Pharmacodynamics
- 12.3 Pharmacokinetics
- 12.5 Pharmacogenomics

13 NONCLINICAL TOXICOLOGY

- 13.1 Carcinogenesis, Mutagenesis, Impairment of Fertility

14 CLINICAL STUDIES

- 14.1 Renal Cell Carcinoma
- 14.2 Soft Tissue Sarcoma

16 HOW SUPPLIED/STORAGE AND HANDLING**17 PATIENT COUNSELING INFORMATION**

*Sections or subsections omitted from the full prescribing information are not listed.

FULL PRESCRIBING INFORMATION

WARNING: HEPATOTOXICITY

Severe and fatal hepatotoxicity has been observed in clinical trials. Monitor hepatic function and interrupt, reduce, or discontinue dosing as recommended [see Warnings and Precautions (5.1)].

1 INDICATIONS AND USAGE

1.1 Renal Cell Carcinoma

VOTRIENT[®] is indicated for the treatment of adults with advanced renal cell carcinoma (RCC).

1.2 Soft Tissue Sarcoma

VOTRIENT is indicated for the treatment of adults with advanced soft tissue sarcoma (STS) who have received prior chemotherapy.

Limitations of Use: The efficacy of VOTRIENT for the treatment of patients with adipocytic STS or gastrointestinal stromal tumors has not been demonstrated.

2 DOSAGE AND ADMINISTRATION

2.1 Recommended Dosage

The recommended dosage of VOTRIENT is 800 mg orally once daily without food (at least 1 hour before or 2 hours after a meal) until disease progression or unacceptable toxicity [see *Clinical Pharmacology (12.3)*]. The dosage should be modified for hepatic impairment and in patients taking certain concomitant drugs [see *Dosage and Administration (2.3, 2.4)*].

Swallow tablets whole. Do not crush tablets due to the potential for increased rate of absorption which may affect systemic exposure [see *Clinical Pharmacology (12.3)*].

If a dose is missed, it should not be taken if it is less than 12 hours until the next dose.

2.2 Dosage Modifications for Adverse Reactions

Table 1 summarizes the recommended dose reductions.

Table 1. Recommended Dose Reductions of VOTRIENT for Adverse Reactions

Dose Reduction	For Renal Cell Carcinoma	For Soft Tissue Sarcoma
First	400 mg orally once daily	600 mg orally once daily
Second	200 mg orally once daily	400 mg orally once daily

Permanently discontinue VOTRIENT in patients unable to tolerate the second dose reduction.

Table 2 summarizes the recommended dosage modifications for adverse reactions.

Table 2. Recommended Dosage Modifications of VOTRIENT for Adverse Reactions

Adverse Reaction	Severity^a	Dosage Modification
Hepatic Toxicity [<i>see Warnings and Precautions (5.1)</i>]	Isolated ALT elevations between $3 \times$ ULN and $8 \times$ ULN	Continue and monitor liver function weekly until ALT returns to Grade 1 or baseline.
	Isolated ALT elevations of $> 8 \times$ ULN	Withhold until improvement to Grade 1 or baseline. If the potential benefit for resuming treatment with VOTRIENT is considered to outweigh the risk for hepatotoxicity, then resume at a reduced dose of no more than 400 mg once daily and measure serum liver tests weekly for 8 weeks. Permanently discontinue if ALT elevations $> 3 \times$ ULN recur despite dose reduction(s).
	ALT elevations $> 3 \times$ ULN occur concurrently with bilirubin elevations $> 2 \times$ ULN	Permanently discontinue and continue to monitor until resolution. Patients with only a mild, indirect (unconjugated) hyperbilirubinemia, known as Gilbert's syndrome, and ALT elevations $> 3 \times$ ULN should be managed per the recommendations outlined for isolated ALT elevations.
Left Ventricular Systolic Dysfunction [<i>see Warnings and Precautions (5.3)</i>]	Symptomatic or Grade 3	Withhold until improvement to Grade < 3 . Resume treatment based on medical judgement.
	Grade 4	Permanently discontinue
Hemorrhagic Events [<i>see Warnings and Precautions (5.4)</i>]	Grade 2	Withhold until improvement to Grade ≤ 1 . Resume at reduced dose (see Table 1). Permanently discontinue if Grade 2 recurs after dose interruption and reduction.
	Grade 3 or 4	Permanently discontinue.
Arterial Thromboembolic Events [<i>see Warnings and Precautions (5.5)</i>]	Any grade	Permanently discontinue.
Venous Thromboembolic Events [<i>see Warnings and Precautions (5.6)</i>]	Grade 3	Withhold VOTRIENT and resume at same dose if managed with appropriate therapy for at least one week.
	Grade 4	Permanently discontinue.

Adverse Reaction	Severity^a	Dosage Modification
Thrombotic Microangiopathy <i>[see Warnings and Precautions (5.7)]</i>	Any grade	Permanently discontinue.
Gastrointestinal Perforation <i>[see Warnings and Precautions (5.8)]</i>	Any grade	Permanently discontinue.
Gastrointestinal Fistula <i>[see Warnings and Precautions (5.8)]</i>	Grade 2 or 3	Withhold and resume based on medical judgement.
	Grade 4	Permanently discontinue.
Interstitial Lung Disease (ILD)/Pneumonitis <i>[see Warnings and Precautions (5.9)]</i>	Any grade	Permanently discontinue.
Posterior Reversible Encephalopathy Syndrome (PRES) <i>[see Warnings and Precautions (5.10)]</i>	Any grade	Permanently discontinue.
Hypertension <i>[see Warnings and Precautions (5.11)]</i>	Grade 2 or 3	Reduce dose (see Table 1) and initiate or adjust anti-hypertensive therapy. Permanently discontinue if hypertension remains Grade 3 despite dose reduction(s) and adjustment of anti-hypertensive therapy.
	Grade 4 or hypertensive crisis	Permanently discontinue.
Proteinuria <i>[see Warnings and Precautions (5.14)]</i>	24-hour urine protein \geq 3 grams	Withhold until improvement to Grade \leq 1. Resume at a reduced dose (see Table 1). Permanently discontinue if 24-hour urine protein \geq 3 grams does not improve or recurs despite dose reductions.
	Confirmed nephrotic syndrome	Permanently discontinue.

Abbreviations: ALT, alanine aminotransferase; LVEF, left ventricular ejection fraction; RCC, renal cell carcinoma; STS, soft tissue sarcoma; ULN, upper limit of normal.

^aNational Cancer Institute Common Terminology Criteria for Adverse Events, version 5.

2.3 Dosage Modifications for Hepatic Impairment

Moderate and Severe Hepatic Impairment

In patients with moderate hepatic impairment [total bilirubin $>$ 1.5 to $3 \times$ upper limit of normal (ULN) and any alanine aminotransferase (ALT) value], consider alternatives to VOTRIENT. If VOTRIENT is used in patients with moderate hepatic impairment, reduce the VOTRIENT dose to 200 mg orally once daily.

VOTRIENT is not recommended in patients with severe hepatic impairment (total bilirubin $> 3 \times$ ULN and any ALT value) [see *Use in Specific Populations (8.7)*].

2.4 Dosage Modifications for Drug Interactions

Strong CYP3A4 Inhibitors

Avoid concomitant use of strong CYP3A4 inhibitors by use of an alternate concomitant medication with no or minimal potential to inhibit CYP3A4. If coadministration of a strong CYP3A4 inhibitor is warranted, reduce the dose of VOTRIENT to 400 mg [see *Drug Interactions (7.1)*].

Strong CYP3A4 Inducers

Avoid concomitant use of strong CYP3A4 inducers by use of an alternate concomitant medication with no or minimal enzyme induction potential. VOTRIENT is not recommended in patients who cannot avoid chronic use of strong CYP3A4 inducers [see *Drug Interactions (7.1)*].

Gastric Acid-Reducing Agents

Avoid concomitant use of gastric acid-reducing agents. If concomitant use of a gastric acid-reducing agent cannot be avoided, consider short-acting antacid in place of proton pump inhibitors (PPIs) and H₂-receptor antagonists. Separate short-acting antacid and VOTRIENT dosing by several hours [see *Drug Interactions (7.4)*, *Clinical Pharmacology (12.3)*].

3 DOSAGE FORMS AND STRENGTHS

Tablets: 200 mg, modified capsule-shaped, gray, film-coated with 'GS JT' debossed on one side.

4 CONTRAINDICATIONS

None.

5 WARNINGS AND PRECAUTIONS

5.1 Hepatic Toxicity

Hepatotoxicity, manifested as increases in alanine aminotransferase (ALT), aspartate aminotransferase (AST) and bilirubin, occurred in patients who received VOTRIENT. This hepatotoxicity can be severe and fatal.

Patients older than 65 years are at greater risk for hepatotoxicity [see *Use in Specific Populations (8.5)*].

Transaminase elevations occur early in the course of treatment; 92% of all transaminase elevations of any grade occurred in the first 18 weeks.

In the randomized RCC trial (VEG105192), ALT $> 3 \times$ upper limit of normal (ULN) occurred in 18% and ALT $> 10 \times$ ULN occurred in 4% of the 290 patients who received VOTRIENT. Concurrent elevation in ALT $> 3 \times$ ULN and bilirubin $> 2 \times$ ULN in the absence of significant alkaline phosphatase $> 3 \times$ ULN occurred in 2%. In the monotherapy trials, 2 patients died with disease progression and hepatic failure.

In the randomized STS trial (VEG110727), ALT $> 3 \times$ ULN occurred in 18% and ALT $> 8 \times$ ULN occurred in 5% of the 240 patients who received VOTRIENT. Concurrent elevation in ALT $> 3 \times$ ULN and bilirubin $> 2 \times$ ULN in the absence of significant alkaline phosphatase $> 3 \times$ ULN occurred in 2%. One patient died of hepatic failure.

Monitor liver tests at baseline; at Weeks 3, 5, 7, and 9; at Month 3 and Month 4; and then periodically as clinically indicated. Increase to weekly monitoring for patients with elevated ALT until ALT returns to Grade 1 or baseline. Withhold VOTRIENT and resume at reduced dose with continued weekly monitoring for 8 weeks, or permanently discontinue with weekly monitoring until resolution based on severity of hepatotoxicity [see *Dosage and Administration (2.2)*].

Gilbert's Syndrome

VOTRIENT is a uridine diphosphate (UDP)-glucuronosyl transferase 1A1 (UGT1A1) inhibitor. Mild, indirect (unconjugated) hyperbilirubinemia may occur in patients with Gilbert's syndrome [see *Clinical Pharmacology (12.5)*]. In patients with only a mild indirect hyperbilirubinemia known as Gilbert's syndrome, manage elevation in ALT > 3 × ULN per the recommendations outlined for isolated ALT elevations [see *Dosage and Administration (2.2)*].

Concomitant Use of Simvastatin

Concomitant use of VOTRIENT and simvastatin increases the risk of ALT elevations [see *Drug Interactions (7.3)*]. Insufficient data are available to assess the risk of concomitant administration of alternative statins and VOTRIENT.

5.2 QT Prolongation and Torsades de Pointes

In the RCC trials, 558/586 patients were subject to routine electrocardiogram (ECG) monitoring and QT prolongation ≥ 500 msec was identified in 2% of these 558 patients. In monotherapy trials, Torsades de pointes occurred in < 1% of 977 patients who received VOTRIENT.

In the randomized RCC (VEG105192) and STS (VEG110727) trials, 1% (3/290) and 0.4% (1/240) of patients, respectively, who received VOTRIENT had post-baseline values between 500 to 549 msec. Post-baseline QT data were only collected in the STS trial if ECG abnormalities were reported as an adverse reaction.

Monitor patients who are at significant risk of developing QTc prolongation, including patients with a history of QT interval prolongation, in patients taking antiarrhythmics or other medications that may prolong QT interval, and those with relevant preexisting cardiac disease [see *Drug Interactions (7.5)*]. Monitor ECG and electrolytes (e.g., calcium, magnesium, potassium) at baseline and as clinically indicated. Correct hypokalemia, hypomagnesemia and hypocalcemia prior to initiating VOTRIENT and during treatment.

5.3 Cardiac Dysfunction

Cardiac dysfunction, including decreased left ventricular ejection fraction (LVEF) and congestive heart failure, occurred in patients who received VOTRIENT.

In the RCC trials, cardiac dysfunction was observed in 0.6% of 586 patients without routine on-study LVEF monitoring. In the randomized RCC trial (VEG105192), myocardial dysfunction was defined as symptoms of cardiac dysfunction or ≥ 15% absolute decline in LVEF compared with baseline or a decline in LVEF of ≥ 10% compared with baseline that is also below the lower limit of normal. In an RCC trial (COMPARZ), myocardial dysfunction occurred in 13% of the 362 patients on VOTRIENT who had a baseline and post-baseline LVEF measurements. Congestive heart failure occurred in 0.5% of patients.

In the randomized STS trial (VEG110727), myocardial dysfunction occurred in 11% of the 142 patients who had a baseline and a post-baseline LVEF measurements. One percent (3/240) of patients who received VOTRIENT had congestive heart failure, which did not resolve in one patient. Fourteen of the 16 patients with myocardial dysfunction treated with VOTRIENT had concurrent hypertension which may have exacerbated cardiac dysfunction in patients at risk (e.g., those with prior anthracycline therapy) possibly by increasing cardiac afterload.

Monitor blood pressure and manage as appropriate [see *Warnings and Precautions (5.11)*]. Monitor for clinical signs or symptoms of congestive heart failure. Conduct baseline and periodic evaluation of LVEF in patients at risk of cardiac dysfunction, including previous anthracycline exposure. Withhold or permanently discontinue VOTRIENT based on severity of cardiac dysfunction [see *Dosage and Administration (2.2)*].

5.4 Hemorrhagic Events

In the RCC trials, fatal hemorrhage occurred in 0.9% of 586 patients, and cerebral/intracranial hemorrhage was observed in less than 1% (2/586) of patients treated with VOTRIENT.

In the randomized RCC trial (VEG105192), 13% of 290 patients treated with VOTRIENT experienced at least 1 hemorrhagic event. The most common hemorrhagic events were hematuria (4%), epistaxis (2%), hemoptysis (2%), and rectal hemorrhage (1%). Nine of 37 patients treated with VOTRIENT who had hemorrhagic events experienced serious events including pulmonary, gastrointestinal, and genitourinary hemorrhage. One percent of patients treated with VOTRIENT died from hemorrhage.

In the randomized STS trial (VEG110727), 22% of 240 patients treated with VOTRIENT experienced at least 1 hemorrhagic event. The most common hemorrhagic events were epistaxis (8%), mouth hemorrhage (3%), and anal hemorrhage (2%). Grade 4 hemorrhagic events occurred in 1% of patients and included intracranial hemorrhage, subarachnoid hemorrhage, and peritoneal hemorrhage.

VOTRIENT has not been studied in patients who have a history of hemoptysis, cerebral hemorrhage, or clinically significant gastrointestinal hemorrhage in the past 6 months. Withhold VOTRIENT and resume at reduced dose or permanently discontinue based on severity of hemorrhagic events [*see Dosage and Administration (2.2)*].

5.5 Arterial Thromboembolic Events

In the RCC trials, fatal arterial thromboembolic events occurred in 0.3% of 586 patients. In the randomized RCC trial (VEG105192), 2% of 290 patients who received VOTRIENT experienced myocardial infarction or ischemia, 0.3% had a cerebrovascular accident, and 1% had an event of transient ischemic attack.

In the randomized STS trial (VEG110727), 2% of 240 patients who received VOTRIENT experienced a myocardial infarction or ischemia and 0.4% had a cerebrovascular accident.

VOTRIENT has not been studied in patients who have had an arterial thromboembolic event within the previous 6 months. Permanently discontinue VOTRIENT in case of an arterial thromboembolic event [*see Dosage and Administration (2.2)*].

5.6 Venous Thromboembolic Events

Venous thromboembolic events (VTEs), including venous thrombosis and fatal pulmonary embolus (PE), occurred in patients who received VOTRIENT.

In the randomized RCC trial (VEG105192), VTEs occurred in 1% of 290 patients who received VOTRIENT. In the randomized STS trial (VEG110727), VTEs were reported in 5% of 240 patients who received VOTRIENT. Fatal PE occurred in 1% (2/240).

Monitor for signs and symptoms of VTE and PE. Withhold VOTRIENT and then resume at same dose or permanently discontinue based on severity of venous thromboembolic event [*see Dosage and Administration (2.2)*].

5.7 Thrombotic Microangiopathy

Thrombotic microangiopathy (TMA), including thrombotic thrombocytopenic purpura (TTP) and hemolytic uremic syndrome (HUS), occurred in clinical trials of VOTRIENT as monotherapy, in combination with bevacizumab, and in combination with topotecan. VOTRIENT is not indicated for use in combination with other agents. Six of the 7 TMA cases occurred within 90 days of the initiation of VOTRIENT. Improvement of TMA was observed after treatment was discontinued.

Monitor for signs and symptoms of TMA. Permanently discontinue VOTRIENT in patients developing TMA. Manage as clinically indicated.

5.8 Gastrointestinal Perforation and Fistula

In the RCC and STS trials, gastrointestinal perforation or fistula occurred in 0.9% of 586 patients and 1% of 382 patients who received VOTRIENT, respectively. Fatal perforations occurred in 0.3% (2/586) of these patients in the RCC trials and in 0.3% (1/382) of these patients in the STS trials.

Monitor for signs and symptoms of gastrointestinal perforation or fistula. Withhold VOTRIENT in case of Grade 2 or 3 gastrointestinal fistula and resume based on medical judgement. Permanently discontinue VOTRIENT in case of gastrointestinal perforation or Grade 4 gastrointestinal fistula [see *Dosage and Administration* (2.2)].

5.9 Interstitial Lung Disease/Pneumonitis

Interstitial lung disease (ILD)/pneumonitis, which can be fatal, has been reported with VOTRIENT across clinical trials. ILD/pneumonitis occurred in 0.1% of patients treated with VOTRIENT.

Monitor patients for pulmonary symptoms indicative of ILD/pneumonitis. Permanently discontinue VOTRIENT in patients who develop ILD or pneumonitis [see *Dosage and Administration* (2.2)].

5.10 Posterior Reversible Encephalopathy Syndrome

Posterior Reversible Encephalopathy Syndrome (PRES) has been reported in patients who received VOTRIENT and may be fatal. PRES is a neurological disorder which can present with headache, seizure, lethargy, confusion, blindness, and other visual and neurologic disturbances. Mild to severe hypertension may be present. Confirm diagnosis of PRES by magnetic resonance imaging.

Permanently discontinue VOTRIENT in patients who develop PRES.

5.11 Hypertension

Hypertension (systolic blood pressure \geq 150 mmHg or diastolic blood pressure \geq 100 mmHg) and hypertensive crisis were observed in patients treated with VOTRIENT.

Approximately 40% of patients who received VOTRIENT experienced hypertension, with Grade 3 occurring in 4% to 7% of patients [see *Adverse Reactions* (6.1)]. About 40% of cases occurred by Day 9 and about 90% of cases occurred in the first 18 weeks across clinical trials. Approximately 1% of patients required permanent discontinuation of VOTRIENT because of hypertension.

Do not initiate VOTRIENT in patients with uncontrolled hypertension. Optimize blood pressure prior to initiating VOTRIENT. Monitor blood pressure as clinically indicated and initiate and adjust antihypertensive therapy as appropriate. Withhold and then dose reduce VOTRIENT or permanently discontinue based on severity of hypertension [see *Dosage and Administration* (2.2)].

5.12 Risk of Impaired Wound Healing

Impaired wound healing complications can occur in patients who receive drugs that inhibit the VEGF signaling pathway. Therefore, VOTRIENT has the potential to adversely affect wound healing.

Withhold VOTRIENT at least 1 week prior to elective surgery. Do not administer for at least 2 weeks following major surgery and until adequate wound healing. The safety of resumption of VOTRIENT after resolution of wound healing complications has not been established.

5.13 Hypothyroidism

Hypothyroidism, confirmed based on a simultaneous rise of TSH and decline of T4, occurred in 7% of 290 patients who received VOTRIENT in the randomized RCC trial (VEG105192) and in 5% of 240 patients who received VOTRIENT in the randomized STS trial (VEG110727). Hypothyroidism occurred in 4% of the 586 patients in the RCC trials and 5% of the 382 patients in the STS trials.

Monitor thyroid tests at baseline, during treatment and as clinically indicated and manage hypothyroidism as appropriate.

5.14 Proteinuria

In the randomized RCC trial (VEG105192), proteinuria occurred in 9% of 290 patients who received VOTRIENT. In 2 patients, proteinuria led to discontinuation of VOTRIENT.

In the randomized STS trial (VEG110727), proteinuria occurred in 1% of 240 patients and nephrotic syndrome occurred in 1 patient. Treatment was discontinued in the patient with nephrotic syndrome.

Perform baseline and periodic urinalysis during treatment with follow up measurement of 24-hour urine protein as clinically indicated. Withhold VOTRIENT then resume at a reduced dose or permanently discontinue based on severity of proteinuria. Permanently discontinue in patients with nephrotic syndrome [see *Dosage and Administration (2.2)*].

5.15 Tumor Lysis Syndrome

Cases of tumor lysis syndrome (TLS), including fatal cases, have been reported in RCC and STS patients treated with VOTRIENT [see *Adverse Reactions (6.2)*]. Patients may be at risk of TLS if they have rapidly growing tumors, a high tumor burden, renal dysfunction, or dehydration. Closely monitor patients at risk, consider appropriate prophylaxis, and treat as clinically indicated.

5.16 Infection

Serious infections (with or without neutropenia), including some with fatal outcome, have been reported. Monitor patients for signs and symptoms of infection. Institute appropriate anti-infective therapy promptly and consider interruption or discontinuation of VOTRIENT for serious infections.

5.17 Increased Toxicity With Other Cancer Therapy

VOTRIENT is not indicated for use in combination with other agents. Clinical trials of VOTRIENT in combination with pemetrexed and lapatinib were terminated early due to increased toxicity and mortality. The fatal toxicities observed included pulmonary hemorrhage, gastrointestinal hemorrhage, and sudden death. A safe and effective combination dose has not been established with these regimens.

5.18 Increased Toxicity in Developing Organs

The safety and effectiveness of VOTRIENT in pediatric patients have not been established. VOTRIENT is not indicated for use in pediatric patients. Based on its mechanism of action, pazopanib may have severe effects on organ growth and maturation during early postnatal development. Administration of pazopanib to juvenile rats less than 21 days old resulted in toxicity to the lungs, liver, heart, and kidney and in death at doses significantly lower than the clinically recommended dose or doses tolerated in older animals. VOTRIENT may potentially cause serious adverse effects on organ development in pediatric patients, particularly in patients younger than 2 years of age [see *Use in Specific Populations (8.4)*].

5.19 Embryo-Fetal Toxicity

Based on findings from animal studies and its mechanism of action, VOTRIENT can cause fetal harm when administered to a pregnant woman. Administration of VOTRIENT to pregnant rats and rabbits during the period of organogenesis resulted in maternal toxicity, teratogenicity, and abortion at systemic exposures lower than that observed at the maximum recommended human dose (MRHD) of 800 mg (based on area under the curve [AUC]).

Advise pregnant women of the potential risk to a fetus. Advise females of reproductive potential to use effective contraception during treatment with VOTRIENT and for at least 2 weeks following the final dose. Advise males (including those who have had vasectomies) with female partners of reproductive potential to use condoms

during treatment with VOTRIENT and for at least 2 weeks after the last dose [see *Use in Specific Populations* (8.1, 8.3)].

6 ADVERSE REACTIONS

The following clinically significant adverse reactions are elsewhere in the labeling:

- Hepatic Toxicity [see *Warnings and Precautions* (5.1)]
- QT Prolongation and Torsades de Pointes [see *Warnings and Precautions* (5.2)]
- Cardiac Dysfunction [see *Warnings and Precautions* (5.3)]
- Hemorrhagic Events [see *Warnings and Precautions* (5.4)]
- Arterial Thromboembolic Events [see *Warnings and Precautions* (5.5,)]
- Venous Thromboembolic Events [see *Warnings and Precautions* (5.6)]
- Thrombotic Microangiopathy (TMA) [see *Warnings and Precautions* (5.7)]
- Gastrointestinal Perforation and Fistula [see *Warnings and Precautions* (5.8)]
- Interstitial Lung Disease (ILD)/Pneumonitis [see *Warnings and Precautions* (5.9)]
- Posterior Reversible Encephalopathy Syndrome (PRES) [see *Warnings and Precautions* (5.10)]
- Hypertension [see *Warnings and Precautions* (5.11)]
- Hypothyroidism [see *Warnings and Precautions* (5.13)]
- Proteinuria [see *Warnings and Precautions* (5.14)]
- Tumor Lysis Syndrome [see *Warnings and Precautions* (5.15)]
- Infection [see *Warnings and Precautions* (5.16)]

6.1 Clinical Trials Experience

Because clinical trials are conducted under widely varying conditions, adverse reaction rates observed in the clinical trials of a drug cannot be directly compared with rates in the clinical trials of another drug and may not reflect the rates observed in practice.

The data described in the WARNINGS AND PRECAUTIONS section reflect exposure of 977 patients who received VOTRIENT as a single agent, including 586 VOTRIENT-treated patients with RCC. With a median duration of treatment of 7.4 months (range, 0.1 to 27.6) in these 977 patients, the most common adverse reactions ($\geq 20\%$) in these 586 patients were diarrhea, hypertension, hair color change, nausea, fatigue, anorexia, and vomiting.

The data described in the WARNINGS AND PRECAUTIONS also reflects exposure of 382 patients with advanced soft tissue sarcoma who received VOTRIENT as a single agent, with a median duration of treatment of 3.6 months (range, 0 to 53). The most common adverse reactions ($\geq 20\%$) in these 382 patients were fatigue, diarrhea, nausea, decreased weight, hypertension, decreased appetite, vomiting, tumor pain, hair color changes, musculoskeletal pain, headache, dysgeusia, dyspnea and skin hypopigmentation.

Renal Cell Carcinoma

The safety of VOTRIENT was evaluated in 290 patients with RCC who participated in VEG105192, a randomized, double-blind, placebo-controlled trial [see *Clinical Studies* (14.1)]. The median duration of treatment was 7.4 months (range, 0 to 23) for patients who received VOTRIENT.

Forty-two percent of patients on VOTRIENT required a dose interruption and 36% required a dose reduction.

Table 3 presents adverse reactions in VEG105192.

Table 3. Adverse Reactions ($\geq 10\%$) in Patients with RCC Who Received VOTRIENT in VEG105192

Adverse Reactions	VOTRIENT (N = 290)			Placebo (N = 145)		
	All Grades ^a	Grade 3	Grade 4	All Grades ^a	Grade 3	Grade 4
	%	%	%	%	%	%
Diarrhea	52	3	< 1	9	< 1	0
Hypertension	40	4	0	10	< 1	0
Hair color changes	38	< 1	0	3	0	0
Nausea	26	< 1	0	9	0	0
Anorexia	22	2	0	10	< 1	0
Vomiting	21	2	< 1	8	2	0
Fatigue	19	2	0	8	1	1
Asthenia	14	3	0	8	0	0
Abdominal pain	11	2	0	1	0	0
Headache	10	0	0	5	0	0

Abbreviation: RCC, renal cell carcinoma.

^aNational Cancer Institute Common Terminology Criteria for Adverse Events, version 3.

Other adverse reactions observed more commonly in patients treated with VOTRIENT than placebo and that occurred in < 10% (any grade) were alopecia (8% versus < 1%), chest pain (5% versus 1%), dysgeusia (8% versus less than 1%), dyspepsia (5% versus less than 1%), dysphonia (4% versus less than 1%), facial edema (1% versus 0%), palmar-plantar erythrodysesthesia (6% versus less than 1%), proteinuria (9% versus 0%), rash (8% versus 3%), skin depigmentation (3% versus 0%), and weight decreased (9% versus 3%).

Table 4 presents the laboratory abnormalities in VEG105192.

Table 4. Select Laboratory Abnormalities (> 10%) in Patients with RCC Who Received VOTRIENT with a Difference Between Arms of ≥ 5% Compared to Placebo in VEG105192

Parameters	VOTRIENT (N = 290)			Placebo (N = 145)		
	All Grades ^a	Grade 3	Grade 4	All Grades ^a	Grade 3	Grade 4
	%	%	%	%	%	%
Chemistry						
ALT increased	53	10	2	22	1	0
AST increased	53	7	< 1	19	< 1	0
Glucose increased	41	< 1	0	33	1	0
Total bilirubin increased	36	3	< 1	10	1	< 1
Phosphorus decreased	34	4	0	11	0	0
Sodium decreased	31	4	1	24	4	0
Magnesium decreased	26	< 1	1	14	0	0
Glucose decreased	17	0	< 1	3	0	0
Hematologic						
Leukopenia	37	0	0	6	0	0
Neutropenia	34	1	< 1	6	0	0
Thrombocytopenia	32	< 1	< 1	5	0	< 1
Lymphocytopenia	31	4	< 1	24	1	0

Abbreviations: ALT, alanine aminotransferase; AST, aspartate aminotransferase; RCC, renal cell carcinoma.

^aNational Cancer Institute Common Terminology Criteria for Adverse Events, version 3.

Additional adverse reactions from other clinical trials in patients with RCC who received VOTRIENT include arthralgia and muscle spasms.

Soft Tissue Sarcoma

The safety of VOTRIENT was evaluated in 240 patients who participated in VEG110727, a randomized, double-blind, placebo-controlled trial [see *Clinical Studies (14.2)*]. The median duration of treatment was 4.5 months (range, 0 to 24) for patients who received VOTRIENT.

Fifty-eight percent of patients on VOTRIENT required a dose interruption and 38% required a dose reduction. Seventeen percent of patients who received VOTRIENT discontinued therapy due to adverse reactions.

Table 5 presents the adverse reactions in VEG110727.

Table 5. Adverse Reactions (≥ 10%) in Patients with STS Who Received VOTRIENT in VEG110727

Adverse Reactions	VOTRIENT (N = 240)			Placebo (N = 123)		
	All Grades ^a	Grade 3	Grade 4	All Grades ^a	Grade 3	Grade 4
	%	%	%	%	%	%
Fatigue	65	13	1	48	4	1
Diarrhea	59	5	0	15	1	0
Nausea	56	3	0	22	2	0
Weight decreased	48	4	0	15	0	0
Hypertension	42	7	0	6	0	0
Appetite decreased	40	6	0	19	0	0
Hair color changes	39	0	0	2	0	0
Vomiting	33	3	0	11	1	0
Tumor pain	29	8	0	21	7	2
Dysgeusia	28	0	0	3	0	0
Headache	23	1	0	8	0	0
Musculoskeletal pain	23	2	0	20	2	0
Myalgia	23	2	0	9	0	0
Gastrointestinal pain	23	3	0	9	4	0
Dyspnea	20	5	< 1	17	5	1
Exfoliative rash	18	< 1	0	9	0	0
Cough	17	< 1	0	12	< 1	0
Peripheral edema	14	2	0	9	2	0
Mucositis	12	2	0	2	0	0
Alopecia	12	0	0	1	0	0
Dizziness	11	1	0	4	0	0
Skin disorder ^b	11	2	0	1	0	0
Skin hypopigmentation	11	0	0	0	0	0
Stomatitis	11	< 1	0	3	0	0
Chest pain	10	2	0	6	0	0

Abbreviation: STS, soft tissue sarcoma.

^aNational Cancer Institute Common Terminology Criteria for Adverse Events, version 3.

^b27 of the 28 cases of skin disorder were palmar-plantar erythrodysesthesia.

Other adverse reactions observed more commonly in patients treated with VOTRIENT that occurred in ≥ 5% of patients and at an incidence of more than 2% difference from placebo included insomnia (9% versus 6%), hypothyroidism (8% versus 0%), dysphonia (8% versus 2%), epistaxis (8% versus 2%), left ventricular dysfunction (8% versus 4%), dyspepsia (7% versus 2%), dry skin (6% versus less than 1%), chills (5% versus 1%), vision blurred (5% versus 2%), and nail disorder (5% versus 0%).

Table 6 presents the laboratory abnormalities in VEG110727.

Table 6. Select Laboratory Abnormalities (> 10%) in Patients with STS Who Received VOTRIENT with a Difference Between Arms of ≥ 5% Compared to Placebo in VEG110727

Parameters	VOTRIENT (N = 240)			Placebo (N = 123)		
	All Grades ^a	Grade 3	Grade 4	All Grades ^a	Grade 3	Grade 4
	%	%	%	%	%	%
Chemistry						
AST increased	51	5	3	22	2	0
ALT increased	46	8	2	18	2	1
Glucose increased	45	< 1	0	35	2	0
Albumin decreased	34	1	0	21	0	0
Alkaline phosphatase increased	32	3	0	23	1	0
Sodium decreased	31	4	0	20	3	0
Total bilirubin increased	29	1	0	7	2	0
Potassium increased	16	1	0	11	0	0
Hematologic						
Leukopenia	44	1	0	15	0	0
Lymphocytopenia	43	10	0	36	9	2
Thrombocytopenia	36	3	1	6	0	0
Neutropenia	33	4	0	7	0	0

Abbreviations: ALT, alanine aminotransferase; AST, aspartate aminotransferase; STS, soft tissue sarcoma.

^aNational Cancer Institute Common Terminology Criteria for Adverse Events, version 3.

Other Clinically Relevant Adverse Reactions

Lipase Elevations

In a single-arm RCC trial (VEG102616), elevated lipase was observed for 27% of 181 patients with available laboratory data. Elevated lipase as an adverse reaction were reported for 4% of 225 patients, including 2.7% (6/225) with Grade 3 and 0.4% (1/225) with Grade 4. In the RCC trials, clinical pancreatitis was observed in > 1% of 586 patients.

Pneumothorax

Two of 290 patients (0.7%) treated with VOTRIENT in the randomized RCC trial (VEG105192) and 8 of 240 patients (3.3%) treated with VOTRIENT in the randomized STS trial (VEG110727) developed a pneumothorax.

Bradycardia

In the randomized RCC trial (VEG105192), bradycardia based on vital signs (< 60 beats per minute) was observed in 19% of 280 patients treated with VOTRIENT. Bradycardia was reported as an adverse reaction in 2% of 290 patients.

In the randomized STS trial (VEG110727), bradycardia based on vital signs (< 60 beats per minute) was observed in 19% of 238 patients treated with VOTRIENT. Bradycardia was reported as an adverse reaction in 2% of 240 patients.

Adverse Reactions in East Asian Patients

In an analysis of pooled clinical trial data (N = 1938) with VOTRIENT, Grade 3 and Grade 4 neutropenia (12% versus 2%), thrombocytopenia (6% versus < 1%) and palmar-plantar erythrodysesthesia (6% versus 2%) were observed more frequently in patients of East Asian descent than in patients of non-East Asian descent.

6.2 Postmarketing Experience

The following adverse reactions have been identified during postapproval use of VOTRIENT. Because these reactions are reported voluntarily from a population of uncertain size, it is not always possible to reliably estimate the frequency or establish a causal relationship to drug exposure.

Blood and Lymphatic System Disorders: Polycythemia

Eye Disorders: Retinal detachment/tear

Gastrointestinal Disorders: Pancreatitis

Metabolic and Nutrition Disorder: Tumor Lysis Syndrome (including fatal cases)

Vascular Disorders: Arterial (including aortic) aneurysms, dissections, and rupture

7 DRUG INTERACTIONS

7.1 Effect of Other Drugs on VOTRIENT

Strong CYP3A4 Inhibitors

Coadministration of pazopanib with strong inhibitors of CYP3A4 increases pazopanib concentrations [*see Clinical Pharmacology (12.3)*]. Avoid coadministration of VOTRIENT with strong CYP3A4 inhibitors and consider an alternate concomitant medication with no or minimal enzyme inhibition potential. If coadministration of a strong CYP3A4 inhibitor cannot be avoided, reduce the dose of VOTRIENT [*see Dosage and Administration (2.4)*].

Strong CYP3A4 Inducers

Coadministration of strong CYP3A4 inducers may decrease plasma pazopanib concentrations. Consider an alternate concomitant medication with no or minimal enzyme induction potential. VOTRIENT is not recommended if chronic use of strong CYP3A4 inducers cannot be avoided [*see Dosage and Administration (2.4)*].

Transporters

Coadministration of strong inhibitors of P-gp or BCRP may increase pazopanib concentrations. Avoid concomitant use of VOTRIENT with strong inhibitors of P-gp or BCRP. Consider selection of alternative concomitant medicinal products with no or minimal potential to inhibit P-gp or BCRP.

7.2 Effects of VOTRIENT on Other Drugs

CYP Substrates

Coadministration of VOTRIENT with agents with narrow therapeutic windows that are metabolized by CYP3A4, CYP2D6, or CYP2C8 may result in inhibition of the metabolism of these products and create the potential for serious adverse reactions. The concomitant use of VOTRIENT with agents with narrow therapeutic windows that are metabolized by CYP3A4, CYP2D6, or CYP2C8 is not recommended [*see Clinical Pharmacology (12.3)*].

7.3 Concomitant Use With Simvastatin

Concomitant use of VOTRIENT with simvastatin increases the incidence of ALT elevations. Across clinical trials of VOTRIENT as a single agent, ALT > 3 × ULN was reported in 126/895 (14%) of patients who did not use statins, compared with 11/41 (27%) of patients who had concomitant use of simvastatin. If a patient receiving concomitant simvastatin develops ALT elevations, increase to weekly monitoring of liver function as recommended. Withhold VOTRIENT and resume at reduced dose, or permanently discontinue based on severity of hepatotoxicity [see *Dosage and Administration (2.2)*, *Warnings and Precautions (5.1)*]. Insufficient data are available to assess the risk of concomitant administration of alternative statins and VOTRIENT.

7.4 Concomitant Use With Gastric Acid-Reducing Agents

Concomitant use of VOTRIENT with esomeprazole, a PPI, decreased the exposure of pazopanib. Avoid concomitant use of VOTRIENT with gastric acid-reducing agents. If concomitant administration with a gastric acid-reducing agent cannot be avoided, consider short-acting antacids in place of PPIs and H₂-receptor antagonists. Separate short-acting antacid and pazopanib dosing by several hours to avoid a reduction in pazopanib exposure [see *Dosage and Administration (2.4)*, *Clinical Pharmacology (12.3)*].

7.5 Drugs That Prolong the QT Interval

VOTRIENT is associated with QTc interval prolongation [see *Warnings and Precautions (5.2)*, *Clinical Pharmacology (12.2)*]. Avoid coadministration of VOTRIENT with drugs known to prolong the QT/QTc interval.

8 USE IN SPECIFIC POPULATIONS

8.1 Pregnancy

Risk Summary

Based on animal reproduction studies and its mechanism of action [see *Clinical Pharmacology (12.1)*], VOTRIENT can cause fetal harm when administered to a pregnant woman. There are no available data on VOTRIENT use in pregnant women to evaluate for a drug-associated risk. In animal developmental and reproductive toxicology studies, oral administration of pazopanib to pregnant rats and rabbits throughout organogenesis resulted in teratogenicity, and abortion at systemic exposures lower than that observed at the MRHD of 800 mg (based on AUC) (see *Data*). Advise pregnant women of the potential risk to a fetus.

The estimated background risk of major birth defects and miscarriage for the indicated population is unknown. All pregnancies have a background risk of birth defect, loss or other adverse outcomes. In the U.S. general population, the estimated background risk of major birth defects in clinically recognized pregnancies and miscarriage is 2 to 4% and 15% to 20%, respectively.

Data

Animal Data

In a female fertility and early embryonic development study, female rats were administered oral pazopanib at least 15 days prior to mating and for 6 days after mating, which resulted in increased pre-implantation loss and early resorptions at dosages greater than or equal to 30 mg/kg/day (approximately 0.4-fold the AUC at the MRHD of 800 mg/day). Total litter resorption was seen at 300 mg/kg/day (approximately 0.8-fold the AUC at the MRHD of 800 mg/day). Postimplantation loss, embryoletality, and decreased fetal body weights were noted in females administered doses greater than or equal to 10 mg/kg/day (approximately 0.3-fold the AUC at the MRHD of 800 mg/day).

In embryo-fetal developmental toxicity studies in rats and rabbits, oral pazopanib was administered to pregnant animals during organogenesis. In rats, dose levels of greater than or equal to 3 mg/kg/day (approximately 0.1-

fold the AUC at the MRHD of 800 mg/day) resulted in teratogenic effects including cardiovascular malformations (retroesophageal subclavian artery, missing innominate artery, changes in the aortic arch), incomplete or absent ossification, increases in postimplantation loss, embryo lethality and reduced fetal body weight. In rabbits, maternal toxicity, increased postimplantation loss and abortion were observed at doses greater than or equal to 30 mg/kg/day (approximately 0.007-fold the AUC at the MRHD of 800 mg/day). In addition, severe maternal body weight loss and 100% litter loss were observed at doses greater than or equal to 100 mg/kg/day (0.02-fold the AUC at the MRHD of 800 mg/day), while fetal weight was reduced at doses greater than or equal to 3 mg/kg/day (AUC not calculated).

8.2 Lactation

Risk Summary

There is no data on the presence of pazopanib or its metabolites in human milk or their effects on the breastfed infant or milk production. Because of the potential for serious adverse reactions in breastfed infants, advise women not to breastfeed during treatment with VOTRIENT and for 2 weeks after the final dose.

8.3 Females and Males of Reproductive Potential

VOTRIENT can cause fetal harm when administered to a pregnant woman [*see Use in Specific Populations (8.1)*].

Pregnancy Testing

Verify pregnancy status of females of reproductive potential prior to starting treatment with VOTRIENT.

Contraception

Females

Advise females of reproductive potential to use effective contraception during treatment with VOTRIENT and for at least 2 weeks after the last dose.

Males

Advise males (including those who have had vasectomies) with female partners of reproductive potential to use condoms during treatment with VOTRIENT and for at least 2 weeks after the last dose.

Infertility

Based on findings from animal studies, VOTRIENT may impair fertility in females and males of reproductive potential while receiving treatment [*see Nonclinical Toxicology (13.1)*].

8.4 Pediatric Use

The safety and effectiveness of VOTRIENT in pediatric patients have not been established.

Juvenile Animal Toxicity Data

In rats, weaning occurs at Day 21 postpartum which approximately equates to a human pediatric age of 2 years. In a juvenile animal toxicology study performed in rats, when animals were dosed from Day 9 through Day 14 postpartum (pre-weaning), pazopanib caused abnormal organ growth/maturation in the kidney, lung, liver, and heart at approximately 0.1-fold the AUC in adults at the MRHD of 800 mg/day of VOTRIENT. At approximately 0.4-fold the AUC in adults at the MRHD of 800 mg/day, pazopanib administration resulted in mortality.

In repeat-dose toxicology studies in rats including 4-week, 13-week, and 26-week administration, toxicities in bone, teeth, and nail beds were observed at doses greater than or equal to 3 mg/kg/day (approximately 0.07-fold the AUC at the MRHD of 800 mg/day). Doses of 300 mg/kg/day (approximately 0.8-fold the AUC at the

MRHD of 800 mg/day) were not tolerated in 13- and 26-week studies and animals required dose reductions due to body weight loss and morbidity. Hypertrophy of epiphyseal growth plates, nail abnormalities (including broken, overgrown, or absent nails) and tooth abnormalities in growing incisor teeth (including excessively long, brittle, broken, and missing teeth, and dentine and enamel degeneration and thinning) were observed in rats at doses greater than or equal to 30 mg/kg/day (approximately 0.35-fold the AUC at the MRHD of 800 mg/day) at 26 weeks, with the onset of tooth and nail bed alterations noted clinically after 4 to 6 weeks. Similar findings were noted in repeat-dose studies in juvenile rats dosed with pazopanib beginning Day 21 postpartum (post-weaning). In the post-weaning animals, the occurrence of changes in teeth and bones occurred earlier and with greater severity than in older animals. There was evidence of tooth degeneration and decreased bone growth at doses greater than or equal to 30 mg/kg (approximately 0.1- to 0.2-fold the AUC at the MRHD of 800 mg/day). Pazopanib exposure in juvenile rats was lower than that seen at the same dose levels in adult animals, based on comparative AUC values. At pazopanib doses approximately 0.5- to 0.7-fold the AUC at the MRHD of 800 mg/day, decreased bone growth in juvenile rats persisted even after the end of the dosing period. Finally, despite lower pazopanib exposures than those reported in adult animals or adult humans, juvenile animals administered 300 mg/kg/dose pazopanib required dose reduction within 4 weeks of dosing initiation due to significant toxicity, although adult animals could tolerate this same dose for at least 3 times as long [*see Warnings and Precautions (5.18)*].

8.5 Geriatric Use

In pooled clinical trials with VOTRIENT, 30% of 2080 patients were aged ≥ 65 years. More patients ≥ 65 years had ALT elevations $> 3 \times$ ULN compared to patients < 65 years (23% versus 18%) [*see Warnings and Precautions (5.1)*].

In the RCC trials, 33% of 586 patients were aged ≥ 65 years. No overall differences in safety or effectiveness of VOTRIENT were observed between these patients and younger patients.

In the STS trials, 24% of 382 patients were aged ≥ 65 years. Patients aged ≥ 65 years had a higher incidence of Grade 3 or 4 fatigue (19% versus 12% for patients aged < 65 years), hypertension (10% versus 6%), decreased appetite (11% versus 2%), ALT elevations (3% versus 2%) and AST elevations (4% versus 1%). In the randomized STS trial (VEG110727), no overall differences in effectiveness of VOTRIENT were observed between patients aged ≥ 65 years and younger patients.

8.6 Renal Impairment

No dose adjustment is recommended for patients with renal impairment. VOTRIENT has not been studied in patients with severe renal impairment or in patients undergoing peritoneal dialysis or hemodialysis.

8.7 Hepatic Impairment

No dose adjustment is required in patients with mild hepatic impairment (either total bilirubin \leq ULN and ALT $>$ ULN or bilirubin > 1 to $1.5 \times$ ULN and any ALT value). VOTRIENT is not recommended in patients with moderate (total bilirubin > 1.5 to $3 \times$ ULN and any ALT value) and severe (total bilirubin $> 3 \times$ ULN and any ALT value) hepatic impairment [*see Dosage and Administration (2.3), Clinical Pharmacology (12.3)*].

10 OVERDOSAGE

Dose-limiting toxicity (Grade 3 fatigue) and Grade 3 hypertension were each observed in 1 of 3 patients dosed at 2,000 mg daily (2.5 times the recommended dose) and 1,000 mg daily (1.25 times the recommended dose), respectively.

Provide general supportive measures to manage an overdose. Hemodialysis is not expected to enhance the elimination of VOTRIENT because pazopanib is not significantly renally excreted and is highly bound to plasma proteins.

11 DESCRIPTION

Pazopanib is a kinase inhibitor. Pazopanib is presented as the hydrochloride salt, with the chemical name 5-[[4-[(2,3-dimethyl-2H-indazol-6-yl)methylamino]-2-pyrimidinyl]amino]-2-methylbenzenesulfonamide monohydrochloride. It has the molecular formula $C_{21}H_{23}N_7O_2S \cdot HCl$ and a molecular weight of 473.99 g/mol.

Pazopanib hydrochloride has the following chemical structure:

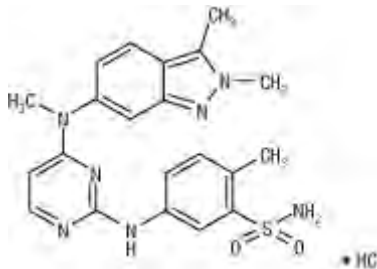

Pazopanib hydrochloride is a white to slightly yellow solid. It is very slightly soluble at pH 1 and practically insoluble above pH 4 in aqueous media.

VOTRIENT tablets are for oral use. Each 200-mg tablet of VOTRIENT contains 200 mg of pazopanib equivalent to 216.7 mg of pazopanib hydrochloride. The inactive ingredients of VOTRIENT are: **Tablet Core:** Magnesium stearate, microcrystalline cellulose, povidone, and sodium starch glycolate. **Coating:** Gray film-coat: Hypromellose, iron oxide black, macrogol/polyethylene glycol 400 (PEG 400), polysorbate 80, and titanium dioxide.

12 CLINICAL PHARMACOLOGY

12.1 Mechanism of Action

Pazopanib is a multi-tyrosine kinase inhibitor of vascular endothelial growth factor receptor (VEGFR)-1, VEGFR-2, VEGFR-3, platelet-derived growth factor receptor (PDGFR)- α and - β , fibroblast growth factor receptor (FGFR)-1 and -3, cytokine receptor (Kit), interleukin-2 receptor-inducible T-cell kinase (Itk), lymphocyte-specific protein tyrosine kinase (Lck), and transmembrane glycoprotein receptor tyrosine kinase (c-Fms). In vitro, pazopanib inhibited ligand-induced autophosphorylation of VEGFR-2, Kit, and PDGFR- β receptors. In vivo, pazopanib inhibited VEGF-induced VEGFR-2 phosphorylation in mouse lungs, angiogenesis in a mouse model, and the growth of some human tumor xenografts in mice.

12.2 Pharmacodynamics

Increases in blood pressure have been observed and are related to steady-state trough plasma pazopanib concentrations.

Cardiac Electrophysiology

The QT prolongation potential of pazopanib was assessed in a randomized, blinded, parallel trial (N = 96) using moxifloxacin as a positive control. VOTRIENT 800 mg orally under fasting conditions was administered on Days 2 to 8 and 1,600 mg was administered on Day 9 after a meal in order to increase exposure to pazopanib and its metabolites. No large changes (i.e., > 20 msec) in QTc interval following exposure to pazopanib were detected in this QT trial. The trial was not able to exclude small changes (< 10 msec) in QTc interval, because assay sensitivity below this threshold (< 10 msec) was not established in this trial [see *Warnings and Precautions* (5.2)].

12.3 Pharmacokinetics

The recommended dosage of 800 mg once daily results in mean AUC of 1,037 mcg•h/mL and C_{max} of 58.1 mcg/mL. There was no consistent increase in AUC or C_{max} at pazopanib doses above 800 mg.

Administration of a single 400-mg crushed tablet increased AUC_{0-72h} by 46% and C_{max} by approximately 2-fold and decreased T_{max} by approximately 2 hours compared with administration of the whole tablet [see *Dosage and Administration (2.1)*].

Absorption

The median time to achieve peak concentrations was 2 to 4 hours after a dose.

Effect of Food

Systemic exposure to pazopanib is increased when administered with food. Administration of pazopanib with a high-fat (approximately 50% fat) or low-fat (approximately 5% fat) meal results in an approximately 2-fold increase in AUC and C_{max} .

Distribution

Binding of pazopanib to human plasma protein in vivo was > 99% with no concentration dependence over the range of 10 to 100 mcg/mL. In vitro studies suggest that pazopanib is a substrate for P-gp and BCRP.

Elimination

Pazopanib has a mean half-life of 31 hours after administration of the recommended dose of 800 mg.

Metabolism

In vitro studies demonstrated that pazopanib is metabolized by CYP3A4 with a minor contribution from CYP1A2 and CYP2C8.

Excretion

Elimination is primarily via feces with renal elimination accounting for < 4% of the administered dose.

Specific Populations

Patients with Hepatic Impairment

Table 7 presents a comparison of the median steady-state C_{max} and the median AUC_{0-24h} values for patients with normal, mild, moderate and severe hepatic impairment.

The median steady-state of pazopanib C_{max} and AUC_{0-24h} after a once-daily dose of 800 mg in patients with mild impairment were in a similar range as the median steady-state C_{max} and median AUC_{0-24h} in patients with no hepatic impairment.

The maximum tolerated pazopanib dose in patients with moderate hepatic impairment was 200 mg once daily. The median steady-state C_{max} and the median AUC_{0-24h} were approximately 43% and 29%, respectively, of the corresponding median values after administration of 800 mg once daily in patients with no hepatic impairment.

The median steady-state C_{max} and the median AUC_{0-24h} were approximately 18% and 15%, respectively, of the corresponding median values after administration of 800 mg once daily in patients with no hepatic impairment.

Table 7. Pharmacokinetic Parameters of Pazopanib in Patients with of Hepatic Impairment

	No Hepatic Impairment	Mild Hepatic Impairment (total bilirubin \leq ULN and ALT > ULN or	Moderate Hepatic Impairment (total bilirubin > 1.5 to 3 \times ULN and any ALT value)	Severe Hepatic Impairment (total bilirubin > 3 \times ULN and any ALT value)
--	------------------------------	---	---	--

		total bilirubin > 1 to 1.5 × ULN and any ALT value)		
Dose	800 mg once daily	800 mg once daily	200 mg once daily	200 mg once daily
Median steady-state C_{max} (range) mcg/mL	52 (17 to 86)	34 (11 to 104)	22 (4.2 to 33)	9.4 (2.4 to 24)
Median AUC_{0-24h} (range) mcg•h/mL	888 (346 to 1482)	774 (215 to 2034)	257 (66 to 488)	131 (47 to 473)

Abbreviations: ALT, alanine aminotransferase; AUC, area under the curve; C_{max}, maximum concentration; PK, pharmacokinetic; ULN, upper limit of normal.

Drug Interactions Studies

Clinical Studies

Strong CYP3A4 Inhibitor: Coadministration of multiple doses of oral VOTRIENT 400 mg with multiple doses of oral ketoconazole 400 mg (strong CYP3A4/P-gp inhibitor) resulted in a 1.7-fold increase in the AUC_{0-24h} and a 1.5-fold increase in the C_{max} of pazopanib [see *Dosage and Administration (2.4)*, *Drug Interactions (7.1)*].

Weak CYP3A4 Inhibitor: Coadministration of 1,500 mg lapatinib, a substrate and weak inhibitor of CYP3A4, P-gp, and BCRP, with VOTRIENT 800 mg resulted in an approximately 50% to 60% increase in mean pazopanib AUC_{0-24h} and C_{max}.

CYP1A2, CYP2C9 and CYP2C19 Substrates: Clinical studies, using VOTRIENT 800 mg once daily, have demonstrated that pazopanib does not have a clinically relevant effect on the pharmacokinetics of caffeine (CYP1A2 probe substrate), warfarin (CYP2C9 probe substrate), or omeprazole (CYP2C19 probe substrate) in patients with cancer.

CYP3A4, CYP2D6, and CYP2C8 Substrates: Coadministration of VOTRIENT resulted in an increase of approximately 30% in the mean AUC and C_{max} of midazolam (CYP3A4 probe substrate) and increases of 33% to 64% in the ratio of dextromethorphan to dextrorphan concentrations in the urine after oral administration of dextromethorphan (CYP2D6 probe substrate). Coadministration of VOTRIENT 800 mg once daily and paclitaxel 80 mg/m² (CYP3A4 and CYP2C8 substrate) once weekly resulted in a mean increase of 26% and 31% in paclitaxel AUC and C_{max}, respectively [see *Drug Interactions (7.2)*].

Gastric Acid-Reducing Agents: Coadministration of VOTRIENT with esomeprazole, a PPI, decreased the exposure of pazopanib by approximately 40% (AUC and C_{max}) [see *Dosage and Administration (2.4)*, *Drug Interactions (7.4)*].

In Vitro Studies

In vitro studies with human liver microsomes showed that pazopanib inhibited the activities of CYP enzymes 1A2, 3A4, 2B6, 2C8, 2C9, 2C19, 2D6, and 2E1. Potential induction of human CYP3A4 was demonstrated in an in vitro human pregnane X receptor (PXR) assay.

In vitro studies also showed that pazopanib inhibits UGT1A1 and organic anion-transporting polypeptide (OATP1B1) with IC₅₀s of 1.2 and 0.79 μM, respectively.

12.5 Pharmacogenomics

Pazopanib can increase serum total bilirubin levels [*see Warnings and Precautions (5.1)*]. In vitro studies showed that pazopanib inhibits UGT1A1, which glucuronidates bilirubin for elimination. A pooled pharmacogenetic analysis of 236 white patients who received VOTRIENT showed that the (TA)7/(TA)7 genotype (UGT1A1*28/*28) (underlying genetic susceptibility to Gilbert's syndrome) was associated with a statistically significant increase in the incidence of hyperbilirubinemia relative to the (TA)6/(TA)6 and (TA)6/(TA)7 genotypes.

In a pooled pharmacogenetic analysis of data from 31 clinical studies of pazopanib administered as either monotherapy or in combination with other agents, ALT > 3 × ULN (Grade 2) occurred in 32% (42/133) of HLA-B*57:01 allele carriers and in 19% (397/2101) of non-carriers and ALT > 5 × ULN (Grade 3) occurred in 19% (25/133) of HLA-B*57:01 allele carriers and in 10% (213/2101) of non-carriers. In this dataset, 6% (133/2234) of the patients carried the HLA-B*57:01 allele [*see Warnings and Precautions (5.1)*].

13 NONCLINICAL TOXICOLOGY

13.1 Carcinogenesis, Mutagenesis, Impairment of Fertility

The carcinogenic potential of pazopanib was evaluated in CD-1 mice, and Sprague-Dawley rats. Administration of pazopanib to mice for 2 years did not result in increased incidence of neoplasms at doses up to 100 mg/kg/day (approximately 1.4-fold the AUC at the MRHD of 800 mg/day). Administration of pazopanib to rats for 2 years resulted in findings of duodenal adenocarcinoma in males at 30 mg/kg/day (approximately 0.3-fold the AUC at the MRHD of 800 mg/day) and in females at greater than or equal to 10 mg/kg/day (approximately 0.3-fold the AUC at the MRHD of 800 mg/day). The human relevance of these neoplastic findings is unclear.

Pazopanib did not induce mutations in the microbial mutagenesis (Ames) assay and was not clastogenic in both the in vitro cytogenetic assay using primary human lymphocytes and in the in vivo rat micronucleus assay.

In an oral female fertility and early embryonic development study, female rats were administered pazopanib at least 15 days prior to mating, and for 6 days after mating. Pazopanib did affect fertility in female rats. Reduced fertility including increased pre-implantation loss and early resorptions were noted at dosages greater than or equal to 30 mg/kg/day (approximately 0.4-fold the AUC at the MRHD of 800 mg/day). Decreased corpora lutea and increased cysts were noted in mice given greater than or equal to 100 mg/kg/day for 13 weeks and ovarian atrophy was noted in rats given greater than or equal to 300 mg/kg/day for 26 weeks (approximately 1.3 and 0.85-fold the AUC at the MRHD of 800 mg/day). Decreased corpora lutea was also noted in monkeys given 500 mg/kg/day for up to 34 weeks (approximately 0.4-fold the AUC at the MRHD of 800 mg/day).

Pazopanib did not affect mating or fertility in male rats. However, there were reductions in sperm production rates and testicular sperm concentrations at doses greater than or equal to 3 mg/kg/day, epididymal sperm concentrations at doses greater than or equal to 30 mg/kg/day, and sperm motility at greater than or equal to 100 mg/kg/day following 15 weeks of dosing. Following 15 and 26 weeks of dosing, there were decreased testicular and epididymal weights at doses of greater than or equal to 30 mg/kg/day (approximately 0.35-fold the AUC at the MRHD of 800 mg/day); atrophy and degeneration of the testes with aspermia, hypospermia, and cribiform change in the epididymis was also observed at this dose in the 6-month toxicity studies in male rats.

14 CLINICAL STUDIES

14.1 Renal Cell Carcinoma

The efficacy of VOTRIENT was evaluated in VEG105192, a randomized, double-blind, placebo-controlled, multicenter trial (NCT00387764). Patients with locally advanced and/or metastatic RCC who had received either no prior therapy or one prior cytokine-based systemic therapy were randomized (2:1) to receive VOTRIENT 800 mg once daily or placebo once daily. Eligible subjects were stratified according to the

following 3 stratification factors: baseline ECOG performance status 0 vs 1; prior nephrectomy yes vs no; and prior systemic therapy for advanced RCC: treatment-naïve vs received one prior cytokine-based therapy. The major efficacy outcome measure was progression-free survival (PFS). Additional outcome measures were overall survival (OS), overall response rate (RR), and duration of response.

Of the total of 435 patients enrolled in this trial, 233 patients had no prior systemic therapy (treatment-naïve subgroup) and 202 patients received one prior IL-2 or INF α -based therapy (cytokine-pretreated subgroup). The baseline demographic and disease characteristics were balanced between the arms receiving VOTRIENT and placebo. The majority of patients were male (71%) with a median age of 59 years. Eighty-six percent of patients were white, 14% were Asian, and less than 1% were other. Forty-two percent were ECOG performance status 0 and 58% were ECOG performance status 1. All patients had clear cell histology (90%) or predominantly clear cell histology (10%). Approximately 50% of all patients had 3 or more organs involved with metastatic disease. The most common metastatic sites at baseline were lung (74%), lymph nodes (56%), bone (27%), and liver (25%).

A similar proportion of patients in each arm were treatment-naïve and cytokine-pretreated (see Table 8). In the cytokine-pretreated subgroup, the majority (75%) had received interferon-based treatment. Similar proportions of patients in each arm had prior nephrectomy (89% and 88% for VOTRIENT and placebo, respectively).

The analysis of the primary endpoint PFS was based on disease assessment by independent radiological review in the entire trial population. Efficacy results are presented in Table 8 and Figure 1.

Table 8. Efficacy Results in RCC Patients by Independent Assessment in VEG105192

Endpoint/Trial Population	VOTRIENT	Placebo	HR (95% CI)
PFS			
Overall ITT	N = 290	N = 145	
Median (months)	9.2	4.2	0.46 ^a (0.34, 0.62)
Treatment-naïve subgroup	N = 155 (53%)	N = 78 (54%)	
Median (months)	11.1	2.8	0.40 (0.27, 0.60)
Cytokine pre-treated subgroup	N = 135 (47%)	N = 67 (46%)	
Median (months)	7.4	4.2	0.54 (0.35, 0.84)
Response Rate (CR + PR)	N = 290	N = 145	
% (95% CI)	30 (25.1, 35.6)	3 (0.5, 6.4)	—
Duration of response			
Median (weeks) (95% CI)	58.7 (52.1, 68.1)	— ^b	

Abbreviations: CI, confidence interval; CR, complete response; HR, hazard ratio; ITT, intent-to-treat; PFS, progression-free survival; PR, partial response; RCC, renal cell carcinoma.

^aP value < 0.001.

^bThere were only 5 objective responses.

Figure 1. Kaplan-Meier Curve for Progression-free Survival in RCC by Independent Assessment for the Overall Population (Treatment-naïve and Cytokine Pre-treated Populations) in VEG105192

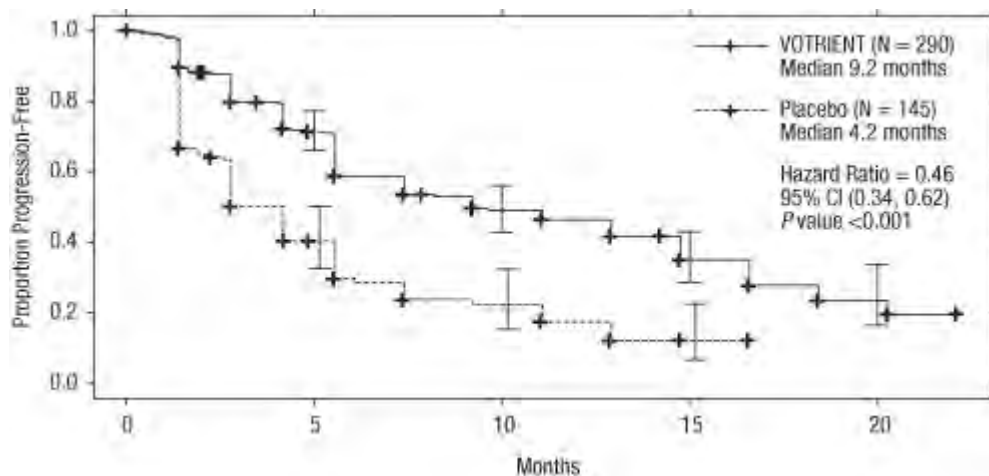

At the protocol-specified final analysis of OS, the median OS was 22.9 months for patients randomized to VOTRIENT and 20.5 months for the placebo arm [HR = 0.91 (95% CI: 0.71, 1.16)]. The median OS for the placebo arm includes 79 patients (54%) who discontinued placebo treatment because of disease progression and crossed over to treatment with VOTRIENT. In the placebo arm, 95 (66%) patients received at least one systemic anticancer treatment after progression compared with 88 (30%) patients randomized to VOTRIENT.

14.2 Soft Tissue Sarcoma

The efficacy of VOTRIENT was evaluated in VEG110727, a randomized, double-blind, placebo-controlled, multicenter trial (NCT00753688). Patients with metastatic STS who had received prior chemotherapy, including anthracycline treatment, or were unsuited for such therapy, were randomized (2:1) to receive VOTRIENT 800 mg once daily or placebo. Patients with gastrointestinal stromal tumors (GIST) or adipocytic sarcoma were excluded from the trial. Randomization was stratified by the factors of WHO performance status (WHO PS) 0 or 1 at baseline and the number of lines of prior systemic therapy for advanced disease (0 or 1 versus 2+). The major efficacy outcome measure was PFS assessed by independent radiological review. Additional outcome measures were OS, overall response rate, and duration of response.

The majority of patients were female (59%) with a median age of 55 years. Seventy-two percent of patients were white, 22% were Asian, and 6% were other. Forty-three percent of patients had leiomyosarcoma, 10% had synovial sarcoma, and 47% had other soft tissue sarcomas. Fifty-six percent of patients had received 2 or more lines of prior systemic therapy and 44% had received 0 or 1 lines of prior systemic therapy.

Efficacy results are presented in Table 9 and Figure 2.

Table 9. Efficacy Results in STS Patients by Independent Assessment in VEG110727

Endpoint/Trial Population	VOTRIENT	Placebo	HR (95% CI)
PFS			
Overall ITT	N = 246	N = 123	0.35 ^a
Median (months)	4.6	1.6	(0.26, 0.48)
Leiomyosarcoma subgroup	N = 109	N = 49	0.37
Median (months)	4.6	1.9	(0.23, 0.60)
Synovial sarcoma subgroup	N = 25	N = 13	0.43
Median (months)	4.1	0.9	(0.19, 0.98)
‘Other soft tissue sarcoma’ subgroup	N = 112	N = 61	0.39
Median (months)	4.6	1.0	(0.25, 0.60)
Response Rate (CR + PR)			
% (95% CI)	4 (2.3, 7.9) ^b	0 (0.0, 3.0)	–
Duration of response			
Median (months) (95% CI)	9.0 (3.9, 9.2)		

Abbreviations: CI, confidence interval; CR, complete response; HR, hazard ratio; ITT, intent-to-treat; PFS, progression-free survival; PR, partial response; STS, soft tissue sarcoma.

^aP value < 0.001.

^bThere were 11 partial responses and 0 complete responses.

Figure 2. Kaplan-Meier Curve for Progression-free Survival in STS by Independent Assessment for the Overall Population in VEG110727

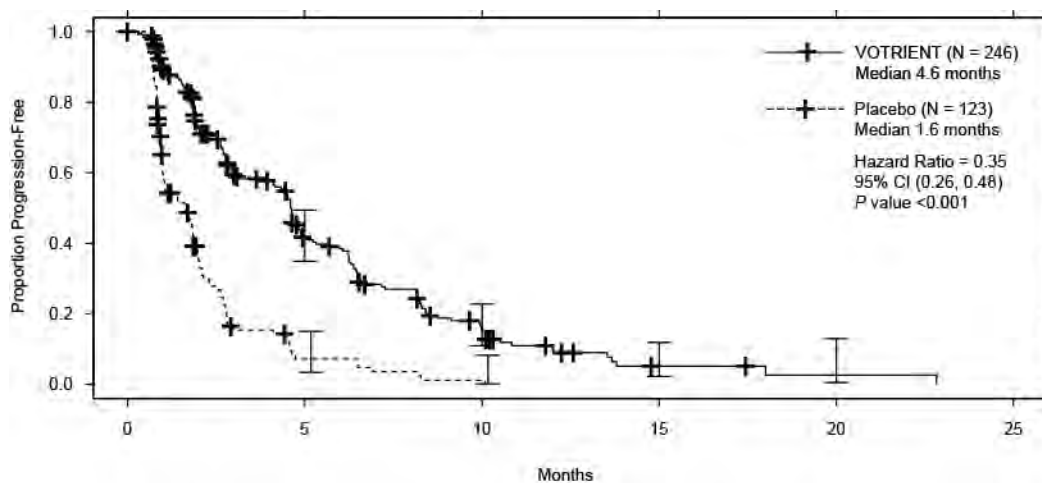

At the protocol-specified final analysis of OS, the median OS was 12.6 months for patients randomized to VOTRIENT and 10.7 months for the placebo arm [HR = 0.87 (95% CI: 0.67, 1.12)].

16 HOW SUPPLIED/STORAGE AND HANDLING

VOTRIENT 200 mg tablets are supplied as modified capsule-shaped, gray, film-coated with ‘GS JT’ debossed on one side and are available in:

- Bottles of 120 tablets: NDC 0078-0670-66

Store at room temperature between 20°C and 25°C (68°F to 77°F); excursions permitted to 15°C to 30°C (59°F to 86°F) [see USP Controlled Room Temperature].

17 PATIENT COUNSELING INFORMATION

Advise the patient to read the FDA-approved patient labeling (Medication Guide).

- **Hepatic Toxicity:** Inform patients that periodic laboratory testing will be performed. Advise patients to report signs and symptoms of liver dysfunction to their healthcare provider right away [see *Warnings and Precautions (5.1)*].
- **QT Prolongation and Torsades de Pointes:** Inform patients that ECG monitoring may be performed. Advise patients to inform their physicians of concomitant medications [see *Warnings and Precautions (5.2)*].
- **Interstitial Lung Disease/Pneumonitis:** Advise patients to report pulmonary signs or symptoms indicative of interstitial lung disease (ILD) or pneumonitis [see *Warnings and Precautions (5.9)*].
- **Cardiac Dysfunction:** Advise patients to report hypertension or signs and symptoms of congestive heart failure [see *Warnings and Precautions (5.3)*].
- **Hemorrhagic Events:** Advise patients to report unusual bleeding [see *Warnings and Precautions (5.4)*].
- **Arterial Thromboembolic Events:** Advise patients to report signs or symptoms of an arterial thrombosis [see *Warnings and Precautions (5.5)*].
- **Pneumothorax and Venous Thromboembolic Events:** Advise patients to report new onset of dyspnea, chest pain, or localized limb edema [see *Warnings and Precautions (5.6), Adverse Reactions (6.1)*].
- **Posterior Reversible Encephalopathy Syndrome:** Advise patients to inform their doctor if they have worsening of neurological function consistent with PRES (headache, seizure, lethargy, confusion, blindness, and other visual and neurologic disturbances) [see *Warnings and Precautions (5.10)*].
- **Hypertension:** Advise patients to monitor blood pressure early in the course of therapy and frequently thereafter and report increases of blood pressure or symptoms such as blurred vision, confusion, severe headache, or nausea and vomiting [see *Warnings and Precautions (5.11)*].
- **Gastrointestinal Perforation and Fistula:** Advise patients to report signs and symptoms of a GI perforation or fistula [see *Warnings and Precautions (5.8)*].
- **Risk of Impaired Wound Healing:** Advise patients that VOTRIENT may impair wound healing. Advise patients to inform their healthcare provider of any scheduled surgical procedure [see *Warnings and Precautions (5.12)*].
- **Hypothyroidism and Proteinuria:** Inform patients that thyroid function testing and urinalysis will be performed during treatment [see *Warnings and Precautions (5.13, 5.14)*].
- **Tumor Lysis Syndrome:** Advise patients to contact their healthcare provider promptly to report any signs and symptoms of TLS such as abnormal heart rhythm, seizure, confusion, muscle cramps or spasms, or a decrease in urine output [see *Warnings and Precautions (5.15)*].
- **Infection:** Advise patients to promptly report any signs or symptoms of infection [see *Warnings and Precautions (5.16)*].
- **Embryo-Fetal Toxicity:** Advise female patients to inform their healthcare provider of a known or suspected pregnancy during treatment with VOTRIENT. Inform female patients of the risk to a fetus and the potential loss of the pregnancy [see *Warnings and Precautions (5.19), Use in Specific Populations (8.1)*].

Advise females of reproductive potential to use effective contraception during treatment and for at least 2 weeks after the last dose of VOTRIENT. Advise male patients with female partners of reproductive potential to use condoms during treatment with VOTRIENT and for at least 2 weeks after the last dose [*see Warnings and Precautions (5.19), Use in Specific Populations (8.3)*].

- Gastrointestinal Adverse Reactions: Advise patients on how to manage nausea, vomiting, and diarrhea and to notify their healthcare provider if moderate-to-severe vomiting or diarrhea occurs or if there is a decrease in oral intake [*see Adverse Reactions (6.1)*].
- Depigmentation: Advise patients that depigmentation of the hair or skin may occur during treatment with VOTRIENT [*see Adverse Reactions (6.1)*].
- Drug Interactions: Advise patients to inform their healthcare providers of all concomitant medications, vitamins, or dietary and herbal supplements [*see Drug Interactions (7)*].
- Dosage and Administration: Advise patients to take VOTRIENT without food (at least 1 hour before or 2 hours after a meal) [*see Dosage and Administration (2.1)*].

Distributed by:

Novartis Pharmaceuticals Corporation
East Hanover, New Jersey 07936

© Novartis

MEDICATION GUIDE
VOTRIENT® (VO-tree-ent)
(pazopanib)
tablets

What is the most important information I should know about VOTRIENT?

VOTRIENT can cause serious liver problems, including death. Your healthcare provider will do blood tests to check your liver before you start and while you take VOTRIENT.

Tell your healthcare provider right away if you get any of these signs of liver problems during treatment with VOTRIENT:

- yellowing of your skin or the whites of your eyes (jaundice)
- dark urine
- tiredness
- nausea or vomiting
- loss of appetite
- pain on the right side of your stomach area (abdomen)
- bruise easily

Your healthcare provider may need to prescribe a lower dose of VOTRIENT for you or tell you to stop taking VOTRIENT if you develop liver problems during treatment.

What is VOTRIENT?

VOTRIENT is a prescription medicine used to treat people with:

- advanced renal cell cancer (RCC)
- advanced soft tissue sarcoma (STS) who have received chemotherapy in the past

It is not known if VOTRIENT is effective in treating certain soft tissue sarcomas or certain gastrointestinal tumors.

It is not known if VOTRIENT is safe and effective in children under 18 years of age.

What should I tell my healthcare provider before taking VOTRIENT?

Before you take VOTRIENT, tell your healthcare provider if you:

- have or had liver problems. You may need a lower dose of VOTRIENT, or your healthcare provider may prescribe a different medicine to treat your advanced renal cell cancer or advanced soft tissue sarcoma.
- have high blood pressure
- have heart problems or an irregular heartbeat including QT prolongation
- have a history of a stroke
- have headaches, seizures, or vision problems
- have coughed up blood in the last 6 months
- had bleeding of your stomach or intestines in the last 6 months
- have a history of a tear (perforation) in your stomach or intestine, or an abnormal connection between two parts of your gastrointestinal tract (fistula)
- have had blood clots in a vein or in the lung
- have thyroid problems
- had recent surgery or are going to have surgery. You should stop taking VOTRIENT at least 1 week before scheduled surgery because VOTRIENT may affect healing after surgery. Do not take VOTRIENT for at least 2 weeks following major surgery and until your wound heals adequately. Your healthcare provider should tell you when you may start taking VOTRIENT again after surgery.
- have problems with your kidney function
- have any other medical conditions
- are pregnant or plan to become pregnant. VOTRIENT can harm your unborn baby. You should not become pregnant while you are taking VOTRIENT. You should use effective birth control during treatment with VOTRIENT and for at least 2 weeks after your final dose of VOTRIENT. Talk to your healthcare provider about types of birth control that may be right for you during this time.
- are a male (including one who has had a vasectomy) with a sexual partner who is pregnant, think that they may be pregnant, or who could become pregnant (including those who use other forms of birth control). You should use condoms during sexual intercourse during treatment with VOTRIENT and for at least 2 weeks after the last dose of

VOTRIENT.

- are breastfeeding or plan to breastfeed. It is not known if VOTRIENT passes into your breast milk. Do not breastfeed during treatment with VOTRIENT and for 2 weeks after the final dose.

Tell your healthcare provider about all the medicines you take, including prescription and over-the-counter medicines, vitamins, and herbal supplements. VOTRIENT may affect the way other medicines work and other medicines may affect how VOTRIENT works.

Especially, tell your healthcare provider if you:

- take medicines that can affect how your liver enzymes work, such as:
 - certain antibiotics (used to treat infections)
 - certain medicines used to treat depression
 - certain medicines used to treat HIV-1
 - medicines used to treat irregular heart beats
- take a medicine that contains simvastatin to treat high cholesterol levels
- take medicines that reduce stomach acid (e.g., esomeprazole)
- drink grapefruit juice

Ask your healthcare provider if you are not sure if your medicine is one that is listed above.

Know the medicines you take. Keep a list of them and show it to your healthcare provider and pharmacist when you get a new medicine.

How should I take VOTRIENT?

- Take VOTRIENT exactly as your healthcare provider tells you. Your healthcare provider will tell you how much VOTRIENT to take.
- Your healthcare provider may change your dose.
- Take VOTRIENT on an empty stomach, at least 1 hour before or 2 hours after food.
- Do not crush VOTRIENT tablets. It may increase the amount of VOTRIENT in your body.
- Do not eat grapefruit or drink grapefruit juice during treatment with VOTRIENT. Grapefruit products may increase the amount of VOTRIENT in your body.
- If you miss a dose, take it as soon as you remember. Do not take it if it is close (within 12 hours) to your next dose. Just take the next dose at your regular time. Do not take more than 1 dose of VOTRIENT at a time.
- Your healthcare provider will test your urine, blood, and heart before you start and while you take VOTRIENT.

What are the possible side effects of VOTRIENT?

VOTRIENT may cause serious side effects including:

- See **“What is the most important information I should know about VOTRIENT?”**
- **irregular or fast heartbeat or fainting**
- **heart failure.** This is a condition where your heart does not pump as well as it should and may cause you to have shortness of breath.
- **bleeding problems.** These bleeding problems may be severe and cause death.
Symptoms may include: unusual bleeding, bruising, or wounds that do not heal.
- **heart attack or stroke.** Heart attack and stroke can happen with VOTRIENT and may cause death.
Symptoms may include: chest pain or pressure, pain in your arms, back, neck or jaw, shortness of breath, numbness or weakness on one side of your body, trouble talking, headache, or dizziness.
- **blood clots.** Blood clots may form in a vein, especially in your legs (deep vein thrombosis or DVT). Pieces of a blood clot may travel to your lungs (pulmonary embolism). This may be life-threatening and cause death.
Symptoms may include: new chest pain, trouble breathing or shortness of breath that starts suddenly, leg pain, and swelling of the arms and hands, or legs and feet, a cool or pale arm or leg.
- **Thrombotic microangiopathy (TMA), including thrombotic thrombocytopenia purpura (TTP) and hemolytic uremic syndrome (HUS).** TMA is a condition involving blood clots that can happen while taking VOTRIENT. TMA is accompanied by a decrease in red blood cells and cells that are involved in clotting. TMA may harm organs such as the brain and kidneys.
- **tear in your stomach or intestinal wall (perforation) or an abnormal connection between two parts of your gastrointestinal tract (fistula).**
Symptoms may include: pain, swelling in your stomach area, vomiting blood, and black sticky stools.

- **lung problems.** VOTRIENT may cause lung problems that may lead to death. Tell your healthcare provider right away if you get a cough that will not go away or shortness of breath.
- **Posterior Reversible Encephalopathy Syndrome (PRES).** PRES is a condition that can happen while taking VOTRIENT that may cause death.
Symptoms may include: headaches, seizures, lack of energy, confusion, high blood pressure, loss of speech, blindness or changes in vision, and problems thinking.
- **high blood pressure. High blood pressure can happen with VOTRIENT, including a sudden and severe rise in blood pressure which may be life-threatening.** These blood pressure increases usually happen in the first several months of treatment. Your blood pressure should be well controlled before you start taking VOTRIENT. Your healthcare provider should begin checking your blood pressure within 1 week of you starting VOTRIENT and often during treatment to make sure that your blood pressure is well controlled.
Have someone call your healthcare provider or get medical help right away for you, if you get symptoms of a severe increase in blood pressure, including: severe chest pain, severe headache, blurred vision, confusion, nausea and vomiting, severe anxiety, shortness of breath, seizures, or you pass out (become unconscious).
- **thyroid problems.** Your healthcare provider should check you for this during treatment with VOTRIENT.
- **Tumor lysis syndrome (TLS).** TLS is a condition that can happen during treatment with VOTRIENT that may cause death. TLS is caused by a fast breakdown of cancer cells. Your healthcare provider may do a blood test to check you for TLS. Call your healthcare provider or get emergency medical help right away if you develop any of these symptoms during treatment with VOTRIENT: irregular heartbeat, seizures, confusion, muscle cramps or spasms, or a decrease in urine output.
- **protein in your urine.** Your healthcare provider will check you for this problem. If there is too much protein in your urine, your healthcare provider may tell you to stop taking VOTRIENT.
- **serious infections. Serious infections can happen with VOTRIENT and can cause death.**
Symptoms of an infection may include: fever, cold symptoms, such as runny nose or sore throat that do not go away, flu symptoms, such as cough, tiredness, and body aches, pain when urinating, cuts, scrapes or wounds that are red, warm, swollen or painful.
- **collapsed lung (pneumothorax).** A collapsed lung can happen with VOTRIENT. Air may get trapped in the space between your lung and chest wall. This may cause you to have shortness of breath.

Call your healthcare provider right away if you have any of the symptoms listed above.

The most common side effects in people who take VOTRIENT include:

- | | |
|------------------------|----------------------|
| • diarrhea | • nausea or vomiting |
| • change in hair color | • loss of appetite |

Other common side effects in people with advanced soft tissue sarcoma who take VOTRIENT include:

- | | |
|-----------------------|------------------------|
| • feeling tired | • headache |
| • decreased weight | • taste changes |
| • tumor pain | • trouble breathing |
| • muscle or bone pain | • change in skin color |
| • stomach pain | |

Tell your healthcare provider if you have any side effect that bothers you or that does not go away.

These are not all the possible side effects of VOTRIENT. For more information, ask your healthcare provider or pharmacist. Call your doctor for medical advice about side effects. You may report side effects to FDA at 1-800-FDA-1088.

How should I store VOTRIENT tablets?

Store VOTRIENT at room temperature between 68°F and 77°F (20°C to 25°C).

Keep VOTRIENT and all medicines out of the reach of children.

General information about the safe and effective use of VOTRIENT.

Medicines are sometimes prescribed for purposes other than those listed in a Medication Guide. Do not use VOTRIENT for a condition for which it was not prescribed. Do not give VOTRIENT to other people even if they have the same symptoms that you have. It may harm them.

If you would like more information, talk with your healthcare provider. You can ask your pharmacist or healthcare provider for information about VOTRIENT that is written for healthcare professionals. For more information, go to www.VOTRIENT.com or call 1-888-669-6682.

What are the ingredients in VOTRIENT?

Active ingredient: pazopanib.

Inactive ingredients: Tablet core: Magnesium stearate, microcrystalline cellulose, povidone, and sodium starch glycolate. **Coating:** Gray film-coat: Hypromellose, iron oxide black, macrogol/polyethylene glycol 400 (PEG 400), polysorbate 80, and titanium dioxide.

Distributed by: Novartis Pharmaceuticals Corporation, East Hanover, New Jersey 07936. © Novartis

This Medication Guide has been approved by the U.S. Food and Drug Administration.

Revised: August 2020

PRODUCT MONOGRAPH

Pr XARELTO[®]

rivaroxaban tablets

2.5 mg, 10 mg, 15 mg and 20 mg

Anticoagulant

(ATC Classification: B01AF01)

Bayer Inc.
2920 Matheson Boulevard East
Mississauga, Ontario
L4W 5R6
Canada
<http://www.bayer.ca>

Date of Revision:
September 20, 2019

Submission Control No: 228528

© 2019, Bayer Inc.
® TM see www.bayer.ca/tm-mc
All other trademarks are the property of their respective owners.

Table of Contents

PART I: HEALTH PROFESSIONAL INFORMATION	3
SUMMARY PRODUCT INFORMATION	3
INDICATIONS AND CLINICAL USE.....	3
CONTRAINDICATIONS	4
WARNINGS AND PRECAUTIONS.....	4
ADVERSE REACTIONS.....	11
DRUG INTERACTIONS	26
DOSAGE AND ADMINISTRATION	30
OVERDOSAGE	36
ACTION AND CLINICAL PHARMACOLOGY	38
STORAGE AND STABILITY	45
DOSAGE FORMS, COMPOSITION AND PACKAGING ¹	45
PART II : SCIENTIFIC INFORMATION	47
PHARMACEUTICAL INFORMATION.....	47
CLINICAL TRIALS.....	48
DETAILED PHARMACOLOGY	83
TOXICOLOGY	87
REFERENCES	89
PART III: CONSUMER INFORMATION	92

XARELTO®

rivaroxaban tablet

PART I: HEALTH PROFESSIONAL INFORMATION

SUMMARY PRODUCT INFORMATION

Table 1 – Product Information Summary

Route of Administration	Dosage Form, Strength	Nonmedicinal Ingredients
Oral	Film-coated tablet, 2.5 mg, 10 mg, 15 mg and 20 mg	Cellulose microcrystalline, croscarmellose sodium, hypromellose 5 cP, lactose monohydrate, magnesium stearate, sodium lauryl sulphate, ferric oxide yellow (2.5 mg), ferric oxide red (10 mg, 15 mg, 20 mg), hypromellose 15 cP, polyethylene glycol, titanium dioxide

INDICATIONS AND CLINICAL USE

XARELTO® (rivaroxaban) film-coated tablet (10 mg, 15 mg, 20 mg) is indicated for the:

- prevention of venous thromboembolic events (VTE) in patients who have undergone elective total hip replacement (THR) or total knee replacement (TKR) surgery.
- treatment of venous thromboembolic events (deep vein thrombosis [DVT], pulmonary embolism [PE]) and prevention of recurrent DVT and PE.
- prevention of stroke and systemic embolism in patients with atrial fibrillation, in whom anticoagulation is appropriate.

XARELTO® (rivaroxaban) film-coated tablet (2.5 mg), in combination with 75 mg – 100 mg acetylsalicylic acid (ASA), is indicated for the:

- prevention of stroke, myocardial infarction and cardiovascular death, and for the prevention of acute limb ischemia and mortality in patients with coronary artery disease (CAD) with or without peripheral artery disease (PAD) (see **DOSAGE AND ADMINISTRATION**).

Acute Pulmonary Embolus in haemodynamically unstable patients, or in those requiring thrombolysis or pulmonary embolectomy

For the treatment of VTE, XARELTO is **not** recommended as an alternative to unfractionated heparin in patients with pulmonary embolus who are haemodynamically unstable, or who may receive thrombolysis or pulmonary embolectomy, since the safety and efficacy of XARELTO have not been established in these clinical situations (see **DOSAGE AND ADMINISTRATION**).

Geriatrics

Clinical studies have included patients with an age > 65 years (see **WARNINGS AND PRECAUTIONS – Geriatrics (>65 Years of Age)** and **Renal Impairment**, and **DOSAGE**

AND ADMINISTRATION – *Renal Impairment* and *Geriatrics (>65 years of age)*). Safety and efficacy data are available (see **CLINICAL TRIALS**).

Pediatrics

The safety and efficacy of XARELTO have not been established in children less than 18 years of age. Therefore, XARELTO is not recommended in this patient population.

CONTRAINDICATIONS

- Clinically significant active bleeding, including gastrointestinal bleeding
- Lesions or conditions at increased risk of clinically significant bleeding, eg, recent cerebral infarction (hemorrhagic or ischemic), active peptic ulcer disease with recent bleeding, patients with spontaneous or acquired impairment of hemostasis
- Concomitant **systemic** treatment with strong inhibitors of **both** CYP 3A4 and P-glycoprotein (P-gp), such as ketoconazole, itraconazole, posaconazole, or ritonavir (see **WARNINGS AND PRECAUTIONS – Drug Interactions**)
- Concomitant treatment with any other anticoagulant, including
 - unfractionated heparin (UFH), except at doses used to maintain a patent central venous or arterial catheter,
 - low molecular weight heparins (LMWH), such as enoxaparin and dalteparin,
 - heparin derivatives, such as fondaparinux, and
 - oral anticoagulants, such as warfarin, dabigatran, apixaban, edoxaban, except under circumstances of switching therapy to or from XARELTO.
- Hepatic disease (including Child-Pugh Class B and C) associated with coagulopathy, and having clinically relevant bleeding risk (see **WARNINGS AND PRECAUTIONS – Hepatic Impairment**)
- Pregnancy (see **WARNINGS AND PRECAUTIONS – Special Populations, Pregnant Women**)
- Nursing women (see **WARNINGS AND PRECAUTIONS – Special Populations, Nursing Women**)
- Hypersensitivity to XARELTO (rivaroxaban) or to any ingredient in the formulation, (see **DOSAGE FORMS, COMPOSITION AND PACKAGING**).

WARNINGS AND PRECAUTIONS

PREMATURE DISCONTINUATION OF ANY ORAL ANTICOAGULANT, INCLUDING XARELTO, INCREASES THE RISK OF THROMBOTIC EVENTS.

To reduce this risk, consider coverage with another anticoagulant if XARELTO is discontinued for a reason other than pathological bleeding or completion of a course of therapy.

Bleeding

XARELTO, like other anticoagulants, should be used with caution in patients with an increased bleeding risk. Bleeding can occur at any site during therapy with XARELTO. The possibility of a hemorrhage should be considered in evaluating the condition of any anticoagulated patient. Any unexplained fall in hemoglobin or blood pressure should lead to a search for a bleeding site.

Patients at high risk of bleeding should not be prescribed XARELTO (see **CONTRAINDICATIONS**).

Should severe bleeding occur, treatment with XARELTO must be discontinued and the source of bleeding investigated promptly.

Close clinical surveillance (looking for signs of bleeding or anemia) is recommended throughout the treatment period, especially in the presence of multiple risk factors for bleeding (see [Table 2](#) below).

Table 2 – Factors Which Increase Hemorrhagic Risk

Factors increasing rivaroxaban plasma levels	Severe renal impairment (CrCl < 30 mL/min)
	Concomitant systemic treatment with strong inhibitors of both CYP 3A4 and P-gp
Pharmacodynamic interactions	NSAID
	Platelet aggregation inhibitors, including ASA, clopidrogrel, prasugrel, ticagrelor
	Selective serotonin reuptake inhibitors (SSRI), and serotonin norepinephrine reuptake inhibitors (SNRIs)
Diseases / procedures with special hemorrhagic risks	Congenital or acquired coagulation disorders
	Thrombocytopenia or functional platelet defects
	Uncontrolled severe arterial hypertension
	Active ulcerative gastrointestinal disease
	Recent gastrointestinal bleeding
	Vascular retinopathy, such as hypertensive or diabetic
	Recent intracranial hemorrhage
	Intraspinal or intracerebral vascular abnormalities
	Recent brain, spinal or ophthalmological surgery
Bronchiectasis or history of pulmonary bleeding	
Others	Age > 75 years

Concomitant use of drugs affecting hemostasis increases the risk of bleeding. Care should be taken if patients are treated concomitantly with drugs affecting hemostasis such as non-steroidal anti-inflammatory drugs (NSAIDs), acetylsalicylic acid (ASA), platelet aggregation inhibitors or selective serotonin reuptake inhibitors (SSRI), and serotonin norepinephrine reuptake inhibitors (SNRIs) (see also **DRUG INTERACTIONS**). Patients on treatment with Xarelto 2.5 mg and ASA should only receive chronic concomitant treatment with NSAIDS, if the benefit outweighs the bleeding risk.

In patients with atrial fibrillation and having a condition that warrants single or dual antiplatelet therapy, a careful assessment of the potential benefits against the potential risks should be made before combining this therapy with XARELTO.

Xarelto 2.5 mg BID has not been studied in combination with, or as replacement of dual antiplatelet therapy (DAPT) for the prevention of stroke, myocardial infarction and cardiovascular death, and for the prevention of acute limb ischemia and mortality in patients with coronary artery disease (CAD) with or without peripheral artery disease (PAD). Xarelto 2.5 mg BID is not indicated in patients with unstable atherosclerotic disease when DAPT is indicated.

Concomitant ASA use (almost exclusively at a dose of 100 mg or less) with either XARELTO or warfarin during the ROCKET-AF trial was identified as an independent risk factor for major bleeding (see also **DRUG INTERACTIONS**).

The antiplatelet agents, prasugrel and ticagrelor, have not been studied with XARELTO, and are not recommended as concomitant therapy.

The use of thrombolytics should generally be avoided during acute myocardial infarction (AMI) or acute stroke in patients treated with rivaroxaban, due to expected increased risk of major bleeding (see **DOSAGE AND ADMINISTRATION – Prevention of Stroke and Systemic Embolism in Patients with Atrial Fibrillation, Other situations requiring thrombolytic therapy**).

Cardiovascular

See **ACTION AND CLINICAL PHARMACOLOGY – Pharmacodynamics**.

Patients with valvular disease

XARELTO is not indicated and is not recommended for thromboprophylaxis in patients having recently undergone transcatheter aortic valve replacement (TAVR). Results from a randomized controlled clinical study (GALILEO) showed that the XARELTO regimen failed to demonstrate clinical benefit compared with an antiplatelet strategy. In the intention-to-treat analysis, all-cause mortality, thromboembolic and bleeding events occurred more frequently in patients randomized to the XARELTO regimen. A causal relationship between XARELTO and all-cause mortality could not be established.

Safety and efficacy of XARELTO have not been studied in patients with other prosthetic heart valves or other valve procedures, or those with hemodynamically significant rheumatic heart disease, especially mitral stenosis. There are no data to support that XARELTO provides adequate anticoagulation in patients with prosthetic heart valves, with or without atrial fibrillation. Therefore, the use of XARELTO is not recommended in this setting.

Of note, in the pivotal Phase III ROCKET AF trial that evaluated XARELTO in the prevention of stroke in atrial fibrillation, 14% of patients had other valvular disease including aortic stenosis, aortic regurgitation, and/or mitral regurgitation. Patients with a history of mitral valve repair were also not excluded from the study. Mitral valve repair rates are not known in ROCKET AF, since information on mitral valve repair status was not specifically collected in this study.

Patients with antiphospholipid syndrome

XARELTO is not recommended for patients with a history of thrombosis who are diagnosed with antiphospholipid syndrome. In particular for patients who are triple positive (for lupus anticoagulant, anticardiolipin antibodies, and anti-beta 2-glycoprotein I antibodies), treatment with rivaroxaban is associated with an increased rate of recurrent thrombotic events compared with vitamin K antagonists.

Patients with nonvalvular atrial fibrillation who undergo PCI (Percutaneous Coronary Intervention) with stent placement

Clinical data are available from an open label interventional study with the primary objective to assess safety in patients with nonvalvular atrial fibrillation who undergo PCI with stent placement. Data on efficacy in this population are limited (see **DOSAGE AND ADMINISTRATION – Prevention of Stroke and Systemic Embolism in Patients with Atrial Fibrillation; ACTION AND CLINICAL PHARMACOLOGY – Pharmacodynamics, Patients with nonvalvular atrial fibrillation who undergo PCI with stent placement**).

Patients with hemorrhagic or lacunar stroke

CAD / PAD patients with a history of previous haemorrhagic or lacunar stroke were not studied. Treatment with XARELTO 2.5 mg twice daily in combination with ASA should be avoided in these patients.

Patients with ischemic, non-lacunar stroke

CAD / PAD patients who have experienced an ischemic, non-lacunar stroke within the previous month were not studied. Treatment with XARELTO 2.5 mg twice daily in combination with ASA should be avoided in the first month after stroke (see **ACTION AND CLINICAL PHARMACOLOGY - Pharmacokinetics**).

Drug Interactions

Interaction with strong inhibitors of both CYP 3A4 and P-gp

The use of XARELTO is contraindicated in patients receiving concomitant **systemic** treatment with strong inhibitors of **both** CYP 3A4 and P-gp, such as ketoconazole, itraconazole, posaconazole, or ritonavir. These drugs may increase XARELTO plasma concentrations to a clinically relevant degree, ie, 2.6-fold on average, which increases bleeding risk.

Interaction with moderate CYP 3A4 inhibitors

The azole anti-mycotic, fluconazole, a moderate CYP 3A4 inhibitor, or erythromycin, have no clinically relevant effect on rivaroxaban exposure (1.4-fold and 1.3-fold increase, respectively) and may be co-administered with XARELTO in patients with normal renal function (see **DRUG INTERACTIONS**).

The use of XARELTO in subjects with mild and moderate renal impairment concomitantly treated with combined P-gp and moderate CYP 3A4 inhibitors such as erythromycin increased exposure to rivaroxaban by 1.8- and 2.0-fold, respectively, compared to subjects with normal renal function without comedication. If such use must be undertaken, caution is required.

Interaction with strong CYP 3A4 inducers

The concomitant use of XARELTO with strong inducers of CYP 3A4, such as rifampicin, and the anticonvulsants, phenytoin, carbamazepine, phenobarbital, reduces rivaroxaban exposure (see **DRUG INTERACTIONS – Drug-Drug Interactions**). Combined use of XARELTO with strong inducers should generally be avoided, since efficacy of XARELTO may be compromised (see **DRUG INTERACTIONS – Drug-Drug Interactions**).

Hepatic Impairment

Patients with significant hepatic disease (eg, acute clinical hepatitis, chronic active hepatitis, liver cirrhosis) were excluded from clinical trials. Therefore, XARELTO is contraindicated in patients with hepatic disease (including Child-Pugh Class B and C) associated with coagulopathy, and having clinically relevant bleeding risk.

The limited data available for patients with mild hepatic impairment without coagulopathy indicate that there is no difference in pharmacodynamic response or pharmacokinetics as compared to healthy subjects.

Surgery / Procedural Interventions

As with any anticoagulant, patients on XARELTO who undergo surgery or invasive procedures are at increased risk for bleeding. In these circumstances, temporary discontinuation of XARELTO may be required.

If a patient concomitantly receiving platelet aggregation inhibitors is to undergo elective surgery and anti-platelet effect is not desired, platelet aggregation inhibitors should be discontinued as directed by the manufacturer's prescribing information.

Limited clinical data are available for patients undergoing fracture-related surgery of the lower limbs. These patients were from a subgroup which was not pre-specified for enrollment in an international, non-interventional (no exclusion criteria), open label cohort study designed to compare the incidence of symptomatic thromboembolic events in patients undergoing elective hip or knee surgery while not randomly assigned to treatment with XARELTO or any local standard-of-care pharmacological therapy.

Pre-Operative Phase

If an invasive procedure or surgical intervention is required, XARELTO 10 mg, 15 mg and 20 mg should be stopped at least 24 hours before the intervention, if possible, due to increased risk of bleeding, and based on clinical judgment of the physician. XARELTO 2.5 mg should be stopped at least 12 hours before the intervention. If a patient is to undergo elective surgery and anti-platelet effect is not desired, platelet aggregation inhibitors should be discontinued as per current treatment guidelines. If the procedure cannot be delayed, the increased risk of bleeding should be assessed against the urgency of the intervention. Although there are limited data, in patients at higher risk of bleeding or in major surgery where complete hemostasis may be required, consider stopping XARELTO two to four days before surgery, depending on clinical circumstances.

Peri-Operative Spinal/Epidural Anesthesia, Lumbar Puncture

When neuraxial (epidural/spinal) anesthesia or spinal puncture is performed, patients treated with antithrombotics for prevention of thromboembolic complications are at risk for developing an epidural or spinal hematoma that may result in long-term neurological injury or permanent paralysis.

The risk of these events is even further increased by the use of indwelling epidural catheters or the concomitant use of drugs affecting hemostasis. Accordingly, the use of XARELTO, at doses greater than 10 mg, is not recommended in patients undergoing anesthesia with post-operative indwelling epidural catheters. The risk may also be increased by traumatic or repeated epidural or spinal puncture. If traumatic puncture occurs, the administration of XARELTO should be delayed for 24 hours.

Patients who have undergone epidural puncture and who are receiving XARELTO 10 mg should be frequently monitored for signs and symptoms of neurological impairment (eg, numbness or weakness of the legs, bowel or bladder dysfunction). If neurological deficits are noted, urgent diagnosis and treatment is necessary.

The physician should consider the potential benefit versus the risk before neuraxial intervention in patients anticoagulated or to be anticoagulated for thromboprophylaxis and use XARELTO 10 mg only when the benefits clearly outweigh the possible risks. An epidural catheter should not be withdrawn earlier than 18 hours after the last administration of XARELTO. XARELTO should be administered not earlier than 6 hours after the removal of the catheter.

There is no clinical experience with the use of XARELTO 15 mg and 20 mg, or XARELTO 2.5 mg in combination with ASA in these situations.

Post-Procedural Period

XARELTO should be restarted following an invasive procedure or surgical intervention as soon as adequate hemostasis has been established and the clinical situation allows, in order to avoid unnecessary increased risk of thrombosis.

Renal Impairment

Following oral dosing with XARELTO, there is a direct relationship between pharmacodynamic effects and the degree of renal impairment (see **ACTION AND CLINICAL PHARMACOLOGY – Renal Insufficiency**).

Determine estimated creatinine clearance (eCrCl) in all patients before instituting XARELTO (see **DOSAGE AND ADMINISTRATION**).

XARELTO should be used with caution in patients with moderate renal impairment (CrCl 30-49 mL/min), especially in those concomitantly receiving other drugs which increase rivaroxaban plasma concentrations (see **DOSAGE AND ADMINISTRATION – Renal Impairment**, and **DRUG INTERACTIONS – Drug-Drug Interactions**).

Physicians should consider the benefit/risk of anticoagulant therapy before administering XARELTO to patients with moderate renal impairment having a creatinine clearance close to the severe renal impairment category (CrCl < 30 mL/min), or in those with a potential to have deterioration of renal function to severe impairment during therapy.

In patients with severe renal impairment (CrCl 15 - <30 mL/min), rivaroxaban plasma levels may be significantly elevated compared to healthy volunteers (1.6-fold on average) which may lead to an increased bleeding risk. Due to limited clinical data, XARELTO must be used with caution in these patients. No clinical data are available for patients with CrCl <15 mL/min. Use is not recommended in patients with CrCL <15ml/min. Patients who develop acute renal failure while on XARELTO should discontinue such treatment.

Due to the high plasma protein binding, ie, about 95%, rivaroxaban is not expected to be removed by dialysis.

Lactose Sensitivity

XARELTO contains lactose. Patients with rare hereditary problems of lactose or galactose intolerance (eg, the Lapp lactase deficiency or glucose-galactose malabsorption) should not take XARELTO.

Special Populations

Pregnant Women

No data are available on the use of XARELTO in pregnant women.

Based on animal data, use of XARELTO is contraindicated throughout pregnancy (see **CONTRAINDICATIONS**, and **TOXICOLOGY – Reproductive Toxicology** and **Lactation**).

If XARELTO is to be used in women of childbearing potential, pregnancy should be avoided.

Nursing Women

No data are available on the use of XARELTO in nursing mothers. In rats, XARELTO is secreted into breast milk. Therefore, XARELTO should only be administered after breastfeeding is discontinued (see **CONTRAINDICATIONS**, and **TOXICOLOGY – Reproductive Toxicology** and **Lactation**).

Geriatrics (>65 Years of Age)

Increasing age is associated with declining renal function. Both of these factors have been observed to result in increased systemic exposure to rivaroxaban, and consequently increased bleeding (see **WARNINGS AND PRECAUTIONS – Renal Impairment**, and **DOSAGE AND ADMINISTRATION – Renal Impairment**).

Increasing age may increase hemorrhagic risk. XARELTO 2.5 mg BID + ASA should be used with caution in patients with chronic CAD with or without PAD \geq 75 years of age. The benefit-risk of the treatment should be individually assessed on a regular basis.

Use with caution in elderly patients, especially those taking concomitant medications that increase systemic exposure of XARELTO (see **WARNINGS AND PRECAUTIONS, Drug Interactions**, and **DRUG INTERACTIONS**).

Pediatrics (<18 Years of Age)

The safety and efficacy of XARELTO have not been established in children less than 18 years of age. Therefore, XARELTO is not recommended in this patient population.

Monitoring and Laboratory Tests

The prothrombin time (PT), measured in seconds, is influenced by XARELTO in a dose-dependent way with a close correlation to plasma concentration if the Neoplastin[®] reagent is used. In patients who are bleeding, measuring the PT using the Neoplastin[®] reagent may be useful to assist in determining an excess of anticoagulant activity (see **DOSAGE AND ADMINISTRATION – Considerations for INR Monitoring of VKA Activity during Concomitant XARELTO Therapy**).

Although XARELTO therapy will lead to an elevated INR, depending on the timing of the measurement (see ACTION AND CLINICAL PHARMACOLOGY – Pharmacodynamics), the INR is not a valid measure to assess the anticoagulant activity of XARELTO. The INR is only calibrated and validated for VKA and should not be used for any other anticoagulant, including XARELTO.

At recommended doses, XARELTO affects the measurement of the aPTT and Heptest[®]. These tests are not recommended for the assessment of the pharmacodynamic effects of XARELTO (see **ACTION AND CLINICAL PHARMACOLOGY – Pharmacodynamics**).

Converting patients from warfarin to XARELTO, or from XARELTO to warfarin, increases prothrombin time by the Neoplastin[®] reagent in seconds (or INR values) more than additively (eg, individual INR values up to 12 may be observed) during concomitant therapy, whereas effects on aPTT and endogenous thrombin potential are additive (see **ACTION AND CLINICAL PHARMACOLOGY – Pharmacodynamics**).

Anti-Factor-Xa activity is influenced by XARELTO in a dose-dependent fashion. If it is desired to test the pharmacodynamic effects of XARELTO during the switching period, tests of anti-Factor-Xa activity can be used as they are not affected by warfarin. Use of these tests to assess the pharmacodynamic effects of XARELTO requires calibration and should not be done unless XARELTO-specific calibrators and controls are available (see **ACTION AND CLINICAL PHARMACOLOGY – Pharmacodynamics**).

Although there is no need to monitor anticoagulation effect of XARELTO during routine clinical practice, in certain infrequent situations such as overdosage, acute bleeding, urgent surgery, in cases of suspected non-compliance, or in other unusual circumstances, assessment of the anticoagulant effect of rivaroxaban may be appropriate. Accordingly, measuring PT using the Neoplastin reagent, or Factor-Xa assay using rivaroxaban-specific calibrators and controls, may be useful to inform clinical decisions in these circumstances.

ADVERSE REACTIONS

Prevention of VTE after THR or TKR

The safety of XARELTO (rivaroxaban) 10 mg has been evaluated in three randomized, double-blind, active-control Phase III studies (RECORD 1, RECORD 2, and RECORD 3). In the Phase III studies, 4657 patients undergoing total hip replacement or total knee replacement surgery were randomized to XARELTO, with 4571 patients actually receiving XARELTO.

In RECORD 1 and 2, a total of 2209 and 1228 THR patients, respectively, were randomized to XARELTO 10 mg od. In RECORD 1, the treatment period for both groups was 35±4 days postoperatively. In RECORD 2, patients randomized to XARELTO were treated for 35 ±4 days

postoperatively, and patients randomized to enoxaparin received placebo after day 12±2 until day 35±4 postoperatively. In RECORD 3, a total of 1220 TKR patients were randomized to XARELTO 10 mg od, and both groups received study drug until day 12±2 postoperatively.

Treatment of VTE and Prevention of Recurrent DVT and PE

The safety of XARELTO has been evaluated in four phase III trials with 6790 patients treated up to 21 months. Patients were exposed to 15 mg XARELTO twice daily for 3 weeks followed by:

- 20 mg once daily (EINSTEIN DVT, EINSTEIN PE) or
- 20 mg once daily after at least 6 months of treatment for DVT or PE (EINSTEIN Extension), or
- 20 mg or 10 mg XARELTO once daily after at least 6 months of treatment for DVT or PE (EINSTEIN CHOICE).

The mean treatment duration was 194 days in EINSTEIN DVT, 183 days in EINSTEIN PE, 188 days in EINSTEIN Extension and 290 days in EINSTEIN CHOICE.

The incidence of adverse events resulting in permanent discontinuation of study drug was 5.0% for XARELTO and 4.4% for enoxaparin/VKA (pooled data from EINSTEIN DVT and EINSTEIN PE), 6.5% for XARELTO and 3.4% for placebo (EINSTEIN Extension) and 4.5% for XARELTO 10 mg, 4.5% for XARELTO 20 mg and 4.2% for ASA (EINSTEIN CHOICE).

Prevention of Stroke and Systemic Embolism in Patients with Atrial Fibrillation (SPAF)

In the pivotal double-blind ROCKET AF study, a total of 14,264 patients with atrial fibrillation at risk for stroke and systemic embolism were randomly assigned to treatment with either rivaroxaban (7,131) or warfarin (7,133) in 45 countries. Patients received XARELTO 20 mg orally once daily (15 mg orally once daily in patients with moderate renal impairment [CrCl: 30-49 mL/min]) or dose-adjusted warfarin titrated to a target INR of 2.0 to 3.0. The safety population included patients who were randomized and took at least 1 dose of study medication. In total, 14,236 patients were included in the safety population, with 7,111 and 7,125 patients in rivaroxaban and warfarin groups, respectively. The median time on treatment was 19 months and overall treatment duration was up to 41 months.

The incidence of adverse events resulting in permanent discontinuation of study drug was 15.8% in the rivaroxaban group and 15.2% in the warfarin group.

Prevention of Stroke, Myocardial Infarction, Cardiovascular Death, and Prevention of Acute Limb Ischemia and Mortality in Patients with CAD with or without PAD

COMPASS, a pivotal Phase III event-driven, randomized, controlled study with a 3 x 2 partial factorial design, randomized 27,395 subjects to receive XARELTO 2.5 mg bid in combination with ASA 100 mg od (9,152), XARELTO 5 mg bid alone (9,117) or ASA 100 mg od (9,126). The intention-to-treat (ITT) analysis set includes all randomized subjects. The median duration of treatment for any of the antithrombotic study drugs was 615 days and was similar for all 3 treatment groups.

The incidence of treatment emergent adverse events leading to permanent discontinuation of antithrombotic study medication was 3.4% in the XARELTO 2.5 mg bid plus ASA 100 mg od arm, and 2.6% in the ASA 100 mg od arm.

Bleeding

Due to the pharmacological mode of action, XARELTO is associated with an increased risk of occult or overt bleeding from any tissue and organ (see **WARNINGS AND PRECAUTIONS – Bleeding**, and **Drug Interactions**). The risk of bleeding may be increased in certain patient groups, eg, patients with uncontrolled severe arterial hypertension and/or on concomitant medication affecting hemostasis (see **Table 2**). The signs, symptoms, and severity (including fatal outcome) will vary according to the location and degree or extent of the bleeding and/or anemia. Hemorrhagic complications may present as weakness, paleness, dizziness, headache or unexplained swelling, dyspnea, and unexplained shock. In some cases as a consequence of anemia, symptoms of cardiac ischemia like chest pain or angina pectoris have been observed. Known complications secondary to severe bleeding such as compartment syndrome and renal failure due to hypoperfusion have been reported for XARELTO. Therefore, the possibility of a hemorrhage should be considered in evaluating the medical condition in any anticoagulated patient.

Major or severe bleeding may occur and, regardless of location, may lead to disabling, life-threatening or even fatal outcomes.

Since the adverse event profiles of the patient populations treated with XARELTO for different indications are not interchangeable, a summary description of major and total bleeding is provided by indication, in **Table 3** for VTE prevention in patients undergoing elective THR or TKR surgery, in **Table 4** for Treatment of VTE and prevention of recurrent DVT and PE, in **Table 5** for stroke prevention in atrial fibrillation, and in **Table 7** for prevention of stroke, myocardial infarction (MI), cardiovascular (CV) death, acute limb ischemia (ALI) and mortality in patients with CAD with or without PAD.

Table 3 - RECORD 1, 2, and 3 (VTE Prevention After THR or TKR) – Treatment-Emergent Bleeding Events (Safety Population with Central Adjudication) in Patients Randomized to XARELTO (First Dose 6 to 8 Hours Postoperatively) or Enoxaparin (First Dose 12 Hours Preoperatively)

		Major Bleeding ^a n (%)	Major Bleeding Including Surgical Site Bleeding Events Associated With Hemoglobin Drops or Transfusions n (%)	Any Bleeding (Major or Nonmajor) n (%)
RECORD 1 (THR)	XARELTO (N=2209) 10 mg od po for 35±4 days	6 (0.3)	40 (1.8)	133 (6.0)
	Enoxaparin (N=2224) 40 mg od SC for 36±4 days	2 (0.1)	33 (1.5)	131 (5.9)
	<i>P</i> -Value	0.18	0.41	0.90
RECORD 2 (THR)	XARELTO (N=1228) 10 mg od po for 35±4 days	1 (0.1)	23 (1.9)	81 (6.6)
	Enoxaparin (N=1229) 40 mg od SC for 12±2 days	1 (0.1)	19 (1.6)	68 (5.5)
	<i>P</i> -Value	1.00	0.54	0.273
RECORD 3 (TKR)	XARELTO (N=1220) 10 mg od po for 12±2 days	7 (0.6)	21 (1.7)	60 (4.9)
	Enoxaparin (N=1239) 40 mg od SC for 13±2 days	6 (0.5)	17 (1.4)	60 (4.8)
	<i>P</i> -Value	0.79	0.52	1.00
Pooled Analysis (RECORD 1, 2, 3)	XARELTO (N=4657)	14 (0.3)	84 (1.8)	274 (5.9)
	Enoxaparin (N=4692) 40 mg od SC	9 (0.2)	69 (1.5)	259 (5.5)
	<i>P</i> -Value	0.31	0.22	0.48

a Major bleeding events included: (1) fatal, (2) bleeding into a critical organ (eg, retroperitoneal, intracranial, intraocular or intraspinal bleeding/hemorrhagic puncture), (3) bleeding requiring reoperation, (4) clinically overt extra-surgical site bleeding associated with ≥ 2 g/dL fall in hemoglobin or leading to infusion of ≥ 2 units of whole blood or packed cells.

See [Table 19](#) and [Table 21](#) for additional details.

od = once daily, po = oral, SC = subcutaneous

Table 4 - Treatment-Emergent Bleeding Events and Results – Safety Population with Central Adjudication - Pooled Analysis, EINSTEIN DVT, EINSTEIN PE, EINSTEIN Extension and EINSTEIN CHOICE (Treatment of VTE and Prevention of Recurrent DVT and PE)

Bleeding event	Pooled EINSTEIN DVT and EINSTEIN PE			EINSTEIN Extension		EINSTEIN CHOICE		
	XARELTO N=4130	Enox/VKA N=4116	HR (95%CI) P-value for superiority	20 mg od N=598	Placebo N=590	XARELTO 10 mg N=1127	XARELTO 20 mg N=1107	ASA 100 mg N=1131
	n (%)	n (%)		n (%)	n (%)	n (%)	n (%)	n (%)
Major and Clinically Relevant Non-major Bleeding ^a	388 (9.4)	412 (10.0)	0.93 (0.81-1.06) P=0.27	36 (6.0)	7 (1.2)	27 (2.4)	36 (3.3)	23(2.0)
Major bleeding ^b	40 (1.0)	72 (1.7)	0.54 (0.37-0.80) P=0.0018*	4 (0.7) ^b	0	5 (0.4)	6 (0.5)	3 (0.3)
Fatal Bleeding	3 (<0.1)	8 (0.2)	-	0	0	0	1 (<0.1)	1 (<0.1)
Intracranial	2 (<0.1)	4 (<0.1)	-	0	0	0	0	1 (<0.1)
Non-Fatal Critical Organ Bleeding	10 (0.2)	29 (0.7)	-	0	0	2 (0.2)	4 (0.4)	1 (<0.1)
Intracranial	3 (<0.1)	10 (0.2)	-	0	0	1 (<0.1)	3 (0.3)	1 (<0.1)
Non-Fatal Non-Critical Organ Bleeding (Fall in Hb ≥ 2 g/dL and/or Transfusions ≥ 2 Units)	27 (0.7)	37 (0.9)	-	4	0	3 (0.3)	1 (<0.1)	1 (<0.1)
Gastrointestinal	12 (0.3)	20 (0.5)	-	3	0	2 (0.2)	1 (<0.1)	1 (<0.1)
Clinically Relevant Non-Major Bleeding	357 (8.6)	357 (8.7)	0.99 (0.85-1.14) P=0.84	32 (5.4) ^b	7 (1.2)	22 (2.0)	30 (2.7)	20 (1.8)

a Primary safety outcome for Pooled EINSTEIN DVT and EINSTEIN PE.

b Primary safety outcome for EINSTEIN Extension and EINSTEIN CHOICE. Major bleeding event was defined as overt bleeding associated with a fall in hemoglobin of 2 g/dL or more; or leading to a transfusion of 2 or more units of packed red blood cells or whole blood; or that occurred in a critical site: intracranial, intraocular, pericardial, intra-articular, intramuscular with compartment syndrome, retroperitoneal; or contributing to death. In EINSTEIN Extension, some patients had more than one event.

See [Table 3](#) for definition of other footnotes.

Clinically relevant non-major bleeding pooled from both EINSTEIN DVT and EINSTEIN PE from a mucosal site occurred in 7.2 % of patients in the XARELTO group and 6.0 % of subjects in the enoxaparin/VKA group. Major bleeding from a mucosal site was observed in 0.6 % of the XARELTO group and 0.7 % of the enoxaparin/VKA group.

Table 5 – ROCKET AF (Prevention of Stroke and Systemic Embolism in Patients with Atrial Fibrillation (SPAF))–Time to the First Occurrence of Bleeding Events While on Treatment (up to Last Dose Plus 2 Days) - Safety Analysis

	XARELTO	Warfarin	HR (95% CI); P-value
	n (%/year)	n (%/year)	
Major and Non-major Clinically Relevant Bleeding	1475 (14.91)	1449 (14.52)	1.03 (0.96,1.11); 0.442
Major Bleeding ^a	395 (3.60)	386 (3.45)	1.04 (0.90,1.20); 0.576
Hemoglobin Drop	305 (2.77)	254 (2.26)	1.22 (1.03,1.44); 0.019*
Transfusion (> 2 units)	183 (1.65)	149 (1.32)	1.25 (1.01,1.55); 0.044*
Critical Organ Bleed	91 (0.82)	133 (1.18)	0.69 (0.53,0.91); 0.007*
Intracranial Hemorrhage	55 (0.49)	84 (0.74)	0.67 (0.47, 0.94); 0.019*
Fatal Bleed	27 (0.24)	55 (0.48)	0.50 (0.31,0.79); 0.003*
Non-major Clinically Relevant Bleeding	1185 (11.80)	1151 (11.37)	1.04 (0.96,1.13); 0.345

a See Table 3 and Table 4 for definition of other footnotes.

* Statistically significant at nominal 0.05 (two-sided).

See Table 28, Table 32, and Table 34 for additional details.

Mucosal major bleeding was more common in the XARELTO group (2.4%/year) as compared to the warfarin group (1.6%/year; HR 1.52 (1.25, 1.83) $P < 0.001$). Most of the mucosal major bleeding was from a gastrointestinal site.

Intracranial hemorrhage and upper gastrointestinal hemorrhage resulting in death were observed in 24/55 (43.6%) and 1/204 (0.5%) XARELTO patients who experienced these adverse events, respectively, compared to 42/84 (50.0%) and 3/125 (2.4%) warfarin patients who experienced these same events, respectively.

Table 6- COMPASS (patients with chronic CAD with or without PAD) – Modified ISTH Major Bleeding and Minor Bleeding (Time to First Event^a) –Intention-to-Treat Analysis

Study Population	Patients with CAD or PAD^b		
	XARELTO 2.5 mg bid in combination with ASA 100 mg od, N=9152	ASA 100 mg od N=9126	Hazard Ratio (95 % CI) p-value^c
Primary safety outcome: Modified ISTH major bleeding	288 (3.1%)	170 (1.9%)	1.70 (1.40;2.05) p < 0.00001*
- Fatal bleeding event	15 (0.2%)	10 (0.1%)	1.49 (0.67;3.33) p = 0.32164
- Symptomatic bleeding in critical organ (non-fatal)	63 (0.7%)	49 (0.5%)	1.28 (0.88;1.86) p = 0.19679

Table 6- COMPASS (patients with chronic CAD with or without PAD) – Modified ISTH Major Bleeding and Minor Bleeding (Time to First Event^a) –Intention-to-Treat Analysis

Study Population Treatment Dosage	Patients with CAD or PAD ^b		
	XARELTO 2.5 mg bid in combination with ASA 100 mg od, N=9152	ASA 100 mg od N=9126	Hazard Ratio (95 % CI) p-value ^c
- Bleeding into the surgical site requiring reoperation (non-fatal, not in critical organ)	10 (0.1%)	8 (0.1%)	1.24 (0.49;3.14) p = 0.65119
- Bleeding leading to hospitalization (non-fatal, non-critical organ, not leading to reoperation)	208 (2.3%)	109 (1.2%)	1.91 (1.51;2.41) p<0.00001*
- Hospitalization where admission date < discharge date	172 (1.9%)	90 (1.0%)	1.91 (1.48;2.46) p<0.00001*
- Hospitalization where admission date = discharge date ^d	36 (0.4%)	21 (0.2%)	1.70 (0.99;2.92) p=0.04983
mISTH Major gastrointestinal bleeding	140 (1.5%)	65 (0.7%)	2.15 (1.60;2.89) p < 0.00001*
mISTH Major intracranial bleeding	28 (0.3%)	24 (0.3%)	1.16 (0.67;2.00) p = 0.59858
Minor Bleeding	838 (9.2%)	503 (5.5%)	1.70 (1.52;1.90) p < 0.001*

^a For each outcome, the first event experienced per subject is considered; therefore, subsequent events of the same type are not shown.

^b Intention-to-treat analysis set, primary analyses.

^c XARELTO 2.5 mg plus ASA 100 mg vs. ASA 100 mg; Log-Rank p-value.

^d Refers to hospitalization or presentation to an acute care facility with discharge the same day.

bid: twice daily; od: once daily; CI: confidence interval; modified ISTH = Modified International Society of Thrombosis and Hemostasis (ISTH) major bleeding is defined as fatal bleeding, symptomatic bleeding into critical area or organ, bleeding into surgical site requiring reoperation or bleeding leading to hospitalization.

- Table includes events that are classified as major bleedings during the adjudication process.

- Each event is counted in the most severe hierarchical category (fatal; critical organ bleeding; bleeding into surgical site requiring re-operation; bleeding leading to hospitalization) only.

* Statistically significant at nominal 0.05 (two-sided).

Clinical Trial Adverse Drug Reactions

Because clinical trials are conducted under very specific conditions, the adverse reaction rates observed in the clinical trials may not reflect the rates observed in practice and should not be compared to the rates in the clinical trials of another drug. Adverse drug reaction information from clinical trials is useful for identifying drug-related adverse events and for approximating rates.

The most common treatment-emergent adverse events in the three Phase III studies for VTE prevention in elective THR and TKR surgery are presented below in [Table 7](#).

Table 7 – Treatment-Emergent Adverse Drug Reactions Occurring in >1% of Any Treatment Group – Pooled Data of RECORD 1, 2, 3 (VTE Prevention After THR or TKR) – (Patients Valid for Safety Analysis^a)

	XARELTO (N=4571)		Enoxaparin (N=4601)	
	n	(%)	n	(%)
Blood and lymphatic system disorders				
Thrombocytosis (including platelet count increased)	77	(1.68)	86	(1.87)
Gastrointestinal disorders				
Nausea	402	(8.79)	402	(8.74)
Diarrhea	101	(2.21)	134	(2.91)
Abdominal and gastrointestinal pain (including upper abdominal pain, stomach discomfort)	88	(1.93)	88	(1.91)
Dyspepsia (including epigastric discomfort)	40	(0.88)	49	(1.06)
Vomiting	371	(8.12)	392	(8.52)
Constipation	293	(6.41)	319	(6.93)
General Disorders and Administration Site Conditions				
Fever	420	(9.19)	427	(9.28)
Decreased general strength and energy (including asthenia, fatigue)	56	(1.23)	45	(0.98)
Edema peripheral	190	(4.16)	160	(3.48)
Injury, poisoning, and post-procedural complications				
Anemia (including laboratory parameter)	263	(5.75)	292	(6.35)
Post procedural hemorrhage	200	(4.38)	192	(4.17)
Wound secretion	125	(2.73)	92	(2.00)
Investigations				
Increase in LDH	37	(0.81)	49	(1.06)
Increase in transaminases	123	(2.69)	190	(4.13)
Increase in Gamma-glutamyltransferase	74	(1.62)	121	(2.63)
Increase in alkaline phosphatase	35	(0.77)	56	(1.22)
Musculoskeletal, Connective Tissue, and Bone Disorders				
Pain in extremity	74	(1.62)	55	(1.20)
Nervous System Disorders				
Dizziness	149	(3.26)	142	(3.09)
Headache	105	(2.30)	96	(2.09)
Syncope (including loss of consciousness)	71	(1.55)	37	(0.80)
Skin and subcutaneous tissue disorders				
Pruritus (including uncommon cases of generalized pruritus)	97	(2.12)	73	(1.59)
Rash	56	(1.23)	57	(1.24)
Vascular disorders				
Hypotension (including blood pressure decreased)	146	(3.19)	147	(3.19)
Haematoma	47	(1.03)	53	(1.15)

Note: Incidence = number of events/number at risk, where: number of events = number of patients reporting the event; number at risk = number of patients in reference population

Only treatment emergent adverse events which occurred up to 2 days after the last dose of study medication are included.

a Started after administration of oral study medication (XARELTO or matching placebo tablet).

The most common treatment-emergent adverse events reported by patients valid for safety analysis in the 3 phase III studies for treatment of VTE and prevention of recurrent DVT and PE are presented in [Table 8](#).

Table 8 - Treatment-Emergent Adverse Reactions occurring in >1% of Any Treatment Group – pooled EINSTEIN DVT (11702 DVT) and EINSTEIN PE (11702 PE); EINSTEIN Extension (11899); EINSTEIN CHOICE (16416)^b (Treatment of VTE and Prevention of Recurrent DVT and PE) - Safety Analysis

	Pooled EINSTEIN DVT and EINSTEIN PE		EINSTEIN Extension		EINSTEIN CHOICE		
	XARELTO (N=4130) n (%)	ENOXAPARIN/VKA (N=4116) n (%)	XARELTO (N=598) n (%)	Placebo (N=590) n (%)	XARELTO 10 mg (N=1127) n (%)	XARELTO 20 mg (N=1107) n (%)	ASA 100 mg (N=1131) n (%)
Blood and lymphatic system disorders							
Anemia	84 (2.03)	62 (1.51)	4 (0.67)	2 (0.34)	1 (<0.1)	3 (0.3)	0
Cardiac disorder							
Tachycardia	55 (1.33)	43 (1.04)	2 (0.33)	0	0	1 (<0.1)	0
Eye disorders							
Conjunctival hemorrhage	39 (0.94)	47 (1.14)	6 (1.00)	0	2 (0.2)	6 (0.5)	4 (0.4)
Gastrointestinal disorders							
Gingival bleeding	93 (2.25)	104 (2.53)	11 (1.84)	2 (0.34)	14 (1.2)	28 (2.5)	12 (1.1)
Rectal hemorrhage	90 (2.18)	56 (1.36)	4 (0.67)	4 (0.68)	9 (0.8)	6 (0.2)	7 (0.6)
Abdominal pain	69 (1.67)	53 (1.29)	2 (0.33)	7 (1.19)	1 (<0.1)	3 (0.3)	2 (0.2)
Abdominal pain upper	71 (1.72)	50 (1.21)	10 (1.67)	1 (0.17)	2 (0.2)	2 (0.2)	5 (0.4)
Constipation	187 (4.53)	174 (4.23)	6 (1.00)	5 (0.85)	2 (0.2)	0	7 (0.6)
Diarrhea	179 (4.33)	164 (3.98)	7 (1.17)	8 (1.36)	4 (0.4)	4 (0.4)	1 (<0.1)
Dyspepsia	60 (1.45)	54 (1.31)	8 (1.34)	4 (0.68)	1 (<0.1)	3 (0.3)	4 (0.4)
Nausea	153 (3.70)	160 (3.89)	7 (1.17)	6 (1.02)	3 (0.3)	3 (0.3)	2 (0.2)
Vomiting	69 (1.67)	96 (2.33)	3 (0.50)	6 (1.02)	0	4 (0.4)	2 (0.2)
General disorders and administration site conditions							
Pyrexia	111 (2.69)	108 (2.62)	5 (0.84)	7 (1.19)	1 (<0.1)	2 (0.2)	0
Edema peripheral	128 (3.10)	135 (3.28)	13 (2.17)	17 (2.88)	0	0	1 (<0.1)
Asthenia	61 (1.48)	60 (1.46)	4 (0.67)	6 (1.02)	1 (<0.1)	1 (<0.1)	1 (<0.1)
Fatigue	90 (2.18)	68 (1.65%)	6 (1.00)	3 (0.51)	1 (<0.1)	1 (<0.1)	3 (0.3)
Injury, poisoning and post-procedural complications							
Wound hemorrhage	59 (1.43)	65 (1.58)	11 (1.84)	7 (1.19)	11 (1.0)	11 (1.0)	8 (0.7)
Contusion	145 (3.51)	197 (4.79)	19 (3.18)	16 (2.71)	0	2 (0.2)	0
Subcutaneous hematoma	44 (1.07)	61 (1.48)	0	2 (0.34)	33 (2.9)	24 (2.2)	33 (2.9)

Table 8 - Treatment-Emergent Adverse Reactions occurring in >1% of Any Treatment Group – pooled EINSTEIN DVT (11702 DVT) and EINSTEIN PE (11702 PE); EINSTEIN Extension (11899); EINSTEIN CHOICE (16416)^b (Treatment of VTE and Prevention of Recurrent DVT and PE) - Safety Analysis

	Pooled EINSTEIN DVT and EINSTEIN PE		EINSTEIN Extension		EINSTEIN CHOICE		
	XARELTO (N=4130) n (%)	ENOXAPARIN/VKA (N=4116) n (%)	XARELTO (N=598) n (%)	Placebo (N=590) n (%)	XARELTO 10 mg (N=1127) n (%)	XARELTO 20 mg (N=1107) n (%)	ASA 100 mg (N=1131) n (%)
Investigations							
Alanine aminotransferase increased ^c	72 (1.74)	129 (3.13)	2 (0.33)	4 (0.68)	-	-	-
Aspartate aminotransferase increased ^c	32 (0.77)	44 (1.07)	4 (0.67)	3 (0.51)	-	-	-
Musculoskeletal, connective tissue and bone disorders							
Pain in extremity	230 (5.57)	221 (5.37)	29 (4.85)	35 (5.93)	4 (0.4)	2 (0.2)	1 (<0.1)
Nervous system disorders							
Headache	284 (6.88)	242 (5.88)	18 (3.01)	15 (2.54)	3 (0.3)	4 (0.4)	3 (0.3)
Dizziness	102 (2.47)	108 (2.62)	6 (1.00)	8 (1.36)	5 (0.4)	4 (0.4)	3 (0.3)
Renal and urinary disorders							
Hematuria	111 (2.69)	113 (2.75)	13 (2.17)	2 (0.34)	0	3 (0.3)	0
Reproductive system and breast disorders							
Menorrhagia ^a	122 (2.95)	64 (1.55)	5 (0.84)	2 (0.34)	10 (0.9)	15 (1.4)	2 (0.2)
Vaginal hemorrhage	54 (1.31)	23 (0.56)	1 (0.17)	5 (0.85)	4 (0.4)	5 (0.5)	2 (0.2)
Respiratory, thoracic and mediastinal disorders							
Epistaxis	307 (7.43)	271 (6.58)	24 (4.01)	11 (1.86)	41 (3.6)	41 (3.7)	29 (2.6)
Hemoptysis	100 (2.42)	98 (2.38)	1 (0.17)	1 (0.17)	0	6 (0.5)	1 (<0.1)

Table 8 - Treatment-Emergent Adverse Reactions occurring in >1% of Any Treatment Group – pooled EINSTEIN DVT (11702 DVT) and EINSTEIN PE (11702 PE); EINSTEIN Extension (11899); EINSTEIN CHOICE (16416)^b (Treatment of VTE and Prevention of Recurrent DVT and PE) - Safety Analysis

	Pooled EINSTEIN DVT and EINSTEIN PE		EINSTEIN Extension		EINSTEIN CHOICE		
	XARELTO (N=4130) n (%)	ENOXAPARIN/VKA (N=4116) n (%)	XARELTO (N=598) n (%)	Placebo (N=590) n (%)	XARELTO 10 mg (N=1127) n (%)	XARELTO 20 mg (N=1107) n (%)	ASA 100 mg (N=1131) n (%)
Skin and subcutaneous tissue disorders							
Pruritus	83 (2.01)	58 (1.41)	2 (0.33)	2 (0.34)	8 (0.7)	3 (0.3)	3 (0.3)
Rash	97 (2.35)	89 (2.16)	5 (0.84)	7 (1.19)	5 (.4)	3 (0.3)	4 (0.4)
Vascular disorders							
Hematoma	91 (2.20)	150 (3.64)	7 (1.17)	8 (1.36)	0	1 (<0.1)	1 (<0.1)

NB: - Percentages calculated with the number of subjects in each group as denominator

- Incidence is based on number of subjects, not number of events
 - Treatment-Emergent (pooled EINSTEIN DVT and EINSTEIN PE) = events that start after randomization and up to 2 days after the last dose of study medication
 - Treatment-Emergent (EINSTEIN Extension) = events that start on or after the first dose of study medication and up to 2 days after the last dose of study medication
- a Observed as very common for rivaroxaban in women <55 years in pooled 11702 DVT and 11702 PE studies
- b According to the protocol, a targeted AE reporting was applied in this study, i.e. all serious adverse events (SAEs), all AEs of special interest, independent if serious or not, all non-serious AEs leading to a permanent study medication discontinuation, and all pregnancies (and their outcomes) in a patient or of the patient's partner needed to be captured on the eCRF and were reported to PV within 24 hours. Investigators could collect AEs on the eCRF, if deemed important.
- c As laboratory measurements related to AST/ALT in Einstein CHOICE were not scheduled but performed as needed, the information is not available

The most common identified treatment-emergent adverse drug reactions in the pivotal Phase III study, ROCKET AF, for prevention of stroke and systemic embolism in patients with atrial fibrillation are presented in [Table 9](#).

Table 9 – Treatment-Emergent Adverse Reactions Occurring in >1% of Any Treatment Group – ROCKET AF (Prevention of Stroke and Systemic Embolism in Patients with Atrial Fibrillation (SPAF)) - Safety Analysis

	XARELTO (N=7111)		Warfarin (N=7125)	
	n	(%)	n	(%)
Blood and lymphatic system disorders				
Anemia	219	(3.08)	143	(2.01)
Eye disorders				
Conjunctival hemorrhage	104	(1.46)	151	(2.12)
Gastrointestinal disorders				
Diarrhea	379	(5.33)	397	(5.57)
Gingival bleeding	263	(3.70)	155	(2.18)
Nausea	194	(2.73)	153	(2.15)
Rectal hemorrhage	149	(2.10)	102	(1.43)
Abdominal pain upper	127	(1.79)	120	(1.68)

Table 9 – Treatment-Emergent Adverse Reactions Occurring in >1% of Any Treatment Group – ROCKET AF (Prevention of Stroke and Systemic Embolism in Patients with Atrial Fibrillation (SPAF)) - Safety Analysis

	XARELTO (N=7111)		Warfarin (N=7125)	
	n	(%)	n	(%)
Vomiting	114	(1.60)	111	(1.56)
Dyspepsia	111	(1.56)	91	(1.28)
Abdominal pain	107	(1.50)	118	(1.66)
Gastrointestinal hemorrhage	100	(1.41)	70	(0.98)
General Disorders and Administration Site Conditions				
Edema peripheral	435	(6.12)	444	(6.23)
Fatigue	223	(3.14)	221	(3.10)
Asthenia	125	(1.76)	106	(1.49)
Pyrexia	72	(1.01)	87	(1.22)
Injury, poisoning and post-procedural complications				
Contusion	196	(2.76)	291	(4.08)
Investigations				
Alanine aminotransferase increased	144	(2.03)	112	(1.57)
Musculoskeletal, Connective Tissue, and Bone Disorders				
Pain in extremity	191	(2.69)	208	(2.92)
Nervous System Disorders				
Dizziness	433	(6.09)	449	(6.30)
Headache	324	(4.56)	363	(5.09)
Syncope	130	(1.83)	108	(1.52)
Renal and urinary disorders				
Hematuria	296	(4.16)	242	(3.40)
Respiratory tract disorders				
Epistaxis	721	(10.14)	609	(8.55)
Hemoptysis	99	(1.39)	100	(1.40)
Skin and subcutaneous tissue disorders				
Ecchymosis	159	(2.24)	234	(3.28)
Pruritus	120	(1.69)	118	(1.66)
Rash	112	(1.58)	129	(1.81)
Vascular disorders				
Hematoma	216	(3.04)	330	(4.63)
Hypotension	141	(1.98)	130	(1.82)

NB: Incidence is based on number of subjects, not number of events

Treatment-Emergent = events that start on or after the first dose of study medication and up to 2 days after the last dose of study medication

The most common identified treatment-emergent adverse drug reactions in the pivotal Phase III study, COMPASS, are presented in [Table 10](#). The COMPASS protocol utilized a selective, or targeted approach to safety data collection. Therefore, efficacy and safety outcomes as well as events expected in this population as specified in the study protocol were not reported as (S)AEs, but were captured on the respective eCRF. This section includes the results of reported TE(S)AEs.

Table 10 – Treatment-Emergent Adverse Reactions Occurring in > 1% of Any Treatment Group – COMPASS (patients with chronic CAD with or without PAD) (Safety Analysis)

	XARELTO 2.5 mg bid plus ASA 100 mg od (n=9134)		ASA 100 mg (n=9107)	
	n	(%)	n	(%)
Infections and infestations				
Viral upper respiratory tract infection	187	2.0%	193	2.1%

NB: Incidence is based on number of subjects, not number of events

Less Common Clinical Trial Adverse Drug Reactions

Incidence is $\geq 0.1\%$ to $< 1\%$ unless specified.

VTE Prevention in Elective THR and TKR Surgery

Cardiac Disorders: tachycardia

Gastrointestinal Disorders: dry mouth, gastrointestinal tract hemorrhage (including gingival bleeding, rectal hemorrhage, hematemesis)

General Disorders and Administration Site Conditions: feeling unwell (including malaise), localized edema

Hepatobiliary Disorders: hepatic impairment ($\geq 0.01\%$ to $< 0.1\%$)

Immune System Disorders: hypersensitivity, anaphylaxis, allergic edema and angioedema, dermatitis allergic

Investigations: bilirubin conjugated increased (with or without concomitant increase of ALT) ($\geq 0.01\%$ to $< 0.1\%$), blood bilirubin increased, increased amylase, increased lipase

Renal and Urinary Disorders: renal impairment (including serum creatinine increased, blood urea increased)

Respiratory Tract Disorders: epistaxis

Skin and Subcutaneous Tissue Disorders: contusion, urticaria (including rare cases of generalized urticaria)

Vascular Disorders: urogenital tract hemorrhage

Treatment of VTE and Prevention of Recurrent DVT and PE:

Incidence is $\geq 0.1\%$ to $< 1\%$ (pooled EINSTEIN DVT, EINSTEIN PE and EINSTEIN Extension) unless specified. Patients rolled over from EINSTEIN DVT or EINSTEIN PE into EINSTEIN Extension are considered as one patient (N=4556).

Cardiac disorder: tachycardia

Gastrointestinal Disorders: gastrointestinal hemorrhage, hematochezia, hemorrhoidal hemorrhage, melena, mouth hemorrhage, abdominal discomfort, abdominal pain lower, dry mouth

General Disorders and Administration Site Conditions: asthenia, feeling abnormal, malaise

Hepatobiliary Disorders: hepatic impairment

Immune System Disorders: hypersensitivity

Injury, poisoning and post-procedural complications: post-procedural hemorrhage, traumatic hematoma, traumatic hemorrhage, subcutaneous haematoma

Investigations: hemoglobin decreased, aspartate aminotransferase increased, liver function test abnormal, hepatic enzyme increased, transaminases increased, blood bilirubin increased, bilirubin conjugated increased (with or without concomitant increase of ALT), gamma-glutamyl transferase increased, blood alkaline phosphatase increased

Nervous System Disorders: syncope, cerebral and intra cranial hemorrhage ($\geq 0.01\%$ to $< 0.1\%$)

Reproductive system and breast disorders: menometrorrhagia, metrorrhagia

Skin and Subcutaneous Tissue Disorders: urticaria, ecchymosis, skin hemorrhage, dermatitis allergic ($\geq 0.01\%$ to $< 0.1\%$)

Vascular Disorders: hypotension

In other clinical studies with XARELTO, occurrences of vascular pseudoaneurysm formation following percutaneous intervention have been observed. Very rare cases of adrenal hemorrhage have been reported.

Prevention of Stroke and Systemic Embolism in Patients with Atrial Fibrillation (SPAF)

Cardiac disorders: tachycardia

Eye disorders: eye hemorrhage, vitreous hemorrhage

Gastrointestinal Disorders: melena, upper gastrointestinal hemorrhage, hemorrhoidal hemorrhage, hematochezia, mouth hemorrhage, lower gastrointestinal hemorrhage, anal hemorrhage, gastric ulcer hemorrhage, gastritis hemorrhagic, gastric hemorrhage, hematemesis, abdominal discomfort, abdominal pain lower, dry mouth

General Disorders and Administration Site Conditions: malaise

Hepatobiliary Disorders: hepatic impairment, hyperbilirubinemia, jaundice ($\geq 0.01\%$ to $< 0.1\%$)

Immune System Disorders: hypersensitivity, anaphylaxis ($\geq 0.01\%$ to $< 0.1\%$), allergic edema and angioedema

Injury, Poisoning, and Post-procedural Complications: post-procedural hemorrhage, wound hemorrhage, traumatic hematoma, incision site hemorrhage, subdural hematoma, subcutaneous hematoma, periorbital hematoma

Investigations: hemoglobin decreased, hematocrit decreased, blood bilirubin increased, liver function test abnormal, aspartate aminotransferase increased, hepatic enzyme increased, blood urine present, creatinine renal clearance decreased, blood creatinine increased, blood urea increased, blood alkaline phosphatase increased, lipase increased, bilirubin conjugated increased (with or without concomitant increase of ALT) ($\geq 0.01\%$ to $< 0.1\%$)

Musculoskeletal, Connective Tissue, and Bone Disorders: hemarthrosis, muscle hemorrhage ($\geq 0.01\%$ to $< 0.1\%$)

Nervous system disorders: loss of consciousness, hemorrhagic stroke, hemorrhage intracranial

Renal and urinary disorders: renal impairment

Reproductive system disorders: vaginal hemorrhage, metrorrhagia

Skin and Subcutaneous Tissue Disorders: dermatitis allergic, rash pruritic, rash erythematous, rash generalized, pruritus generalized, urticaria, skin hemorrhage

Vascular disorders: hemorrhage, bleeding varicose vein

Prevention of Stroke, Myocardial Infarction and Cardiovascular Death and Prevention of Acute Limb Ischemia and Mortality in Patients with CAD with or without PAD

Blood and Lymphatic System Disorders: anaemia

Cardiac Disorders: atrial fibrillation

Ear and Labyrinth Disorders: vertigo

Eye Disorders: cataract, conjunctival hemorrhage

Gastrointestinal Disorders: abdominal discomfort, abdominal pain, abdominal pain upper, constipation, dental caries, diarrhea, dyspepsia, gastritis, gingival bleeding, large intestine polyp, lip hemorrhage, melaena, nausea, stomatitis,

General Disorders and Administration Site Conditions: chest pain

Infections and Infestations: bronchitis, cellulitis, gastroenteritis, herpes zoster, influenza, periodontitis, pharyngitis, pneumonia, sepsis,

Injury, poisoning and procedural complications: confusion

Investigations: occult blood positive

Metabolism and Nutrition Disorders: diabetes mellitus

Musculoskeletal and Connective tissue disorders: arthralgia, back pain, lumbar spinal stenosis, musculoskeletal pain, osteoarthritis, pain in extremity, spinal osteoarthritis

Neoplasms Benign, Malignant and Unspecified (incl Cysts and Polyps): lung neoplasm malignant, prostate cancer

Nervous System Disorders: dizziness, headache

Renal and Urinary Disorders: acute kidney injury, hematuria, renal failure

Reproductive System and Breast Disorders: benign prostatic hyperplasia

Respiratory, Thoracic and Mediastinal Disorders: epistaxis, hemoptysis, upper respiratory tract inflammation

Skin and Subcutaneous Tissue Disorders: eczema, hemorrhage subcutaneous, pruritus, rash, urticarial

Postmarketing Adverse Drug Reactions

The following adverse reactions have been identified during post-approval use of XARELTO. Because these reactions are reported voluntarily from a population of uncertain size, it is not always possible to reliably estimate their frequency or establish a causal relationship to drug exposure.

Blood and the Lymphatic System Disorders: agranulocytosis, thrombocytopenia

Hepatobiliary Disorders: cholestasis, hepatitis (including hepatocellular injury)

Immune System Disorders: anaphylaxis, allergic edema and angioedema (with or without urticaria)

Skin and Subcutaneous Tissue Disorders: Stevens-Johnson syndrome, drug reaction with eosinophilia and systemic symptoms (DRESS)

Abnormal Hematologic and Clinical Chemistry Findings

In Phase III clinical trials, in VTE prevention, Treatment of VTE and prevention of recurrent DVT and PE, and SPAF the incidence of increases in transaminases in the XARELTO and comparator arms were similar, see [Table 7](#), [Table 8](#), and [Table 9](#) above.

DRUG INTERACTIONS

XARELTO (rivaroxaban) neither inhibits nor induces CYP 3A4 or any other major CYP isoenzymes.

Concomitant use of drugs affecting hemostasis increases the risk of bleeding. Care should be taken if patients are treated concomitantly with drugs affecting hemostasis such as nonsteroidal anti-inflammatory drugs (NSAIDs), acetylsalicylic acid, and platelet aggregation inhibitors. Due to the increased bleeding risk, generally avoid concomitant use with other anticoagulants (see [WARNINGS AND PRECAUTIONS – Bleeding](#)).

Drug-Drug Interactions

The use of XARELTO is contraindicated in patients receiving concomitant **systemic** treatment with strong inhibitors of **both** CYP 3A4 and P-gp such as ketoconazole, itraconazole, posaconazole, or ritonavir). These drugs may increase XARELTO plasma concentrations to a clinically relevant degree, ie, 2.6-fold on average, which may lead to bleeding. The azole anti-mycotic, fluconazole, a moderate CYP 3A4 inhibitor, has less effect on rivaroxaban exposure and may be co-administered with caution (see [CONTRAINDICATIONS](#), and [WARNINGS AND PRECAUTIONS – Drug Interactions](#)).

In the ROCKET AF clinical trial in patients with atrial fibrillation, no apparent increase in major bleeding was observed in patients in whom amiodarone, a moderate CYP 3A4 inhibitor, was co-administered with rivaroxaban.

Drugs strongly inhibiting only one of the XARELTO elimination pathways, either CYP 3A4 or P-gp, are expected to increase XARELTO plasma concentrations to a lesser extent. The expected increase is considered less clinically relevant, see [Table 11](#).

Table 11 – Established or Potential Drug-Drug Interactions

Concomitant Drug Class: Drug Name	Reference	Effect	Clinical Comment
Azole antimycotic: ketoconazole	CT	Co-administration of XARELTO with the azole-antimycotic ketoconazole (400 mg od) a strong CYP 3A4 and P-gp inhibitor, led to a 2.6-fold increase in mean XARELTO steady state AUC and a 1.7-fold increase in mean XARELTO C _{max} , with significant increases in its pharmacodynamic effects.	The use of XARELTO is contraindicated in patients receiving systemic treatment with ketoconazole (see CONTRAINDICATIONS and WARNINGS AND PRECAUTIONS – Drug Interactions and Renal Impairment).
fluconazole	CT	Administration of the moderate CYP 3A4 inhibitor fluconazole (400 mg once daily) led to a 1.4-fold increase in mean XARELTO AUC and a 1.3-fold increase in mean C _{max} .	No dose adjustment is required.
Protease inhibitor: ritonavir	CT	Co-administration of XARELTO with the HIV protease inhibitor ritonavir (600 mg bid), a strong CYP 3A4 and P-gp inhibitor, led to a 2.5-fold increase in mean XARELTO AUC and a 1.6-fold increase in mean XARELTO C _{max} , with significant increases in its pharmacodynamic effects.	The use of XARELTO is contraindicated in patients receiving systemic treatment with ritonavir (see CONTRAINDICATIONS and WARNINGS AND PRECAUTIONS – Drug Interactions and Renal Impairment).
Anti-infectives: erythromycin	CT	Erythromycin (500 mg tid), which inhibits CYP 3A4 and P-gp moderately, led to a 1.3-fold increase in mean XARELTO AUC and C _{max} .	No dose adjustment is required. For patients with renal impairment see WARNINGS AND PRECAUTIONS – Drug Interactions and DETAILED PHARMACOLOGY – Special Populations and Conditions – Renal Insufficiency
clarithromycin	CT	Clarithromycin (500 mg bid), considered a strong CYP 3A4 inhibitor and moderate P-gp inhibitor, led to a 1.5-fold increase in mean rivaroxaban, and a 1.4-fold increase in C _{max} .	The use of XARELTO in combination with clarithromycin may increase the risk of bleeding particularly in patients with underlying disease conditions, and elderly. Caution is required.
rifampicin	CT	Co-administration of XARELTO with the strong CYP 3A4 and P-gp inducer rifampicin led to an approximate 50% decrease in mean XARELTO AUC, with parallel decreases in its pharmacodynamic effects.	Strong CYP 3A4 inducers should generally be avoided in combination with XARELTO, as such use can be expected to result in inadequate anticoagulation.
Anticonvulsants: phenytoin carbamazepine phenobarbital	T	The concomitant use of XARELTO with strong CYP 3A4 inducers (eg, phenytoin, carbamazepine, or phenobarbital) may also lead to a decreased XARELTO plasma concentration.	Strong CYP 3A4 inducers should generally be avoided in combination with XARELTO, as such use can be expected to result in inadequate anticoagulation.

Table 11 – Established or Potential Drug-Drug Interactions

Concomitant Drug Class: Drug Name	Reference	Effect	Clinical Comment
Nonsteroidal Anti-inflammatory Drugs (NSAID): naproxen	CT	Co-administration with naproxen did not affect XARELTO bioavailability and pharmacokinetics. No clinically relevant prolongation of bleeding time was observed when 500 mg naproxen was pre-administered 24 hours before concomitant administration of single doses of XARELTO 15 mg and naproxen 500 mg in healthy subjects.	Concomitant use with XARELTO may increase the risk of bleeding. Promptly evaluate any signs or symptoms of blood loss (see WARNINGS AND PRECAUTIONS – Drug Interactions).
acetylsalicylic acid (ASA)	CT	No clinically significant pharmacokinetic or pharmacodynamic interactions were observed when 500 mg ASA was pre-administered 24 hours before concomitant administration of single doses of XARELTO 15 mg and ASA 100 mg in healthy subjects.	Concomitant use with XARELTO increases the risk of bleeding. Promptly evaluate any signs or symptoms of blood loss (see WARNINGS AND PRECAUTIONS – Drug Interactions). For patients in the ROCKET AF trial, concomitant ASA use (almost exclusively at 100 mg or less) was identified as an independent risk factor for major bleeding with both XARELTO and warfarin.
Antiplatelet drugs: clopidogrel	CT	In two drug interaction studies of 11 and 13 healthy subjects, clopidogrel 300 mg was pre-administered 24 hours before concomitant administration of single doses of XARELTO 15 mg and clopidogrel 75 mg in healthy subjects. Clopidogrel with or without XARELTO led to an approximately 2-fold increase in the median bleeding time (normal range 2 - 8 minutes). In these studies, between 30% and 40% of subjects who received both XARELTO and clopidogrel had maximum bleeding times of up to 45 minutes. XARELTO alone did not lead to a change in bleeding time at 4 hours or 2 days after administration. There was no change in the pharmacokinetics of either drug.	Concomitant use with XARELTO increases the risk of bleeding. Promptly evaluate any signs or symptoms of blood loss (see WARNINGS AND PRECAUTIONS – Drug Interactions).

Table 11 – Established or Potential Drug-Drug Interactions

Concomitant Drug Class: Drug Name	Reference	Effect	Clinical Comment
Antithrombotic: enoxaparin	CT	After combined administration of enoxaparin (40 mg single dose) with XARELTO (10 mg single dose), an additive effect on anti-Factor-Xa activity was observed, without any additional effects on clotting tests (PT, aPTT). Enoxaparin did not affect the bioavailability and pharmacokinetics of XARELTO.	Co-administration of XARELTO at doses ≥ 10 mg with other anticoagulants or antithrombotic therapy has not been adequately studied in clinical trials. Due to the increased bleeding risk, generally avoid concomitant use with other anticoagulants (see WARNINGS AND PRECAUTIONS – Drug Interactions).
Selective serotonin reuptake inhibitors (SSRI), and serotonin norepinephrine reuptake inhibitors (SNRIs)	T, CT	When concomitantly used in the XARELTO clinical program, numerically higher rates of major or non-major clinically relevant bleeding were observed	As with other anticoagulants, patients on XARELTO are at increased risk of bleeding in case of concomitant use with SSRIs or SNRIs due to their reported effect on platelets.

Legend: CT=Clinical Trial; T=Theoretical

No pharmacokinetic interaction was observed between warfarin and XARELTO.

There were no mutual pharmacokinetic interactions observed between XARELTO and midazolam (substrate of CYP 3A4), digoxin (substrate of P-gp), or atorvastatin (substrate of CYP 3A4 and P-gp).

Co-administration of the proton pump inhibitor, omeprazole, the H₂-receptor antagonist, ranitidine, the antacid, aluminum hydroxide / magnesium hydroxide, or naproxen, clopidogrel, or enoxaparin did not affect XARELTO bioavailability or pharmacokinetics.

Drug-Food Interactions

XARELTO 2.5 mg and 10 mg may be taken with or without food. XARELTO 15 mg and 20 mg should be taken with food (see **ACTION AND CLINICAL PHARMACOLOGY – Pharmacokinetics**).

Grapefruit juice is a moderate CYP 3A4 inhibitor. Therefore, an increase in XARELTO exposure following grapefruit juice consumption is not expected to be clinically relevant.

Drug-Herb Interactions

The concomitant use of XARELTO with strong CYP 3A4 inducers (eg, St. John’s Wort) may lead to a decreased XARELTO plasma concentration. Strong CYP 3A4 inducers should generally be avoided in combination with XARELTO, as such use can be expected to result in inadequate anticoagulation.

Drug-Laboratory Interactions

Although various clotting parameter tests (PT, aPTT, Heptest[®]) are affected by the mode of action of XARELTO, none of these clotting tests have been demonstrated to reliably assess the

anticoagulant activity of rivaroxaban following XARELTO administration under usual conditions (see **WARNINGS AND PRECAUTIONS – Monitoring and Laboratory Tests**, and **ACTION AND CLINICAL PHARMACOLOGY – Pharmacodynamics**).

The prothrombin time (PT), measured in seconds, is influenced by XARELTO in a dose-dependent way with a close correlation to plasma concentrations if the Neoplastin[®] reagent is used. In patients who are bleeding, measuring the PT (Neoplastin[®] reagent) in seconds, but not INR, may be useful to assist in determining an excess of anticoagulant activity (see **WARNINGS AND PRECAUTIONS – Monitoring and Laboratory Tests**).

DOSAGE AND ADMINISTRATION

As for any non-vitamin K antagonist oral anticoagulant (NOAC) drug, before initiating XARELTO (rivaroxaban), ensure that the patient understands and is prepared to accept adherence to NOAC therapy, as directed.

Determine estimated creatinine clearance (eCrCl) in all patients before instituting XARELTO (rivaroxaban), and monitor renal function during XARELTO treatment, as clinically appropriate. Determination of renal function by eCrCl should occur at least once per year, and especially during circumstances when renal function may be expected to be compromised, ie, acute myocardial infarction (AMI), acute decompensated heart failure (AHF), increased use of diuretics, dehydration, hypovolemia, etc. Clinically relevant deterioration of renal function may require dosage adjustment or discontinuation of XARELTO (see below, **Renal Impairment**).

Glomerular filtration rate may be estimated by calculating eCrCl, using the Cockcroft-Gault formula:

eCrCl (mL/min)=

in males: $\frac{(140-\text{age}) (\text{years}) \times \text{weight} (\text{kg}) \times 1.23}{\text{serum creatinine} (\mu\text{mol/L})}$ or, $\frac{(140-\text{age}) (\text{yrs}) \times \text{weight} (\text{kg})}{72 \times \text{serum creatinine} (\text{mg}/100 \text{ mL})}$

in females: $\frac{(140-\text{age}) (\text{years}) \times \text{weight} (\text{kg}) \times 1.04}{\text{serum creatinine} (\mu\text{mol/L})}$ or, $\frac{(140-\text{age}) (\text{yrs}) \times \text{weight} (\text{kg}) \times 0.85}{72 \times \text{serum creatinine} (\text{mg}/100 \text{ mL})}$

Recommended Dose and Dosage Adjustment

Prevention of VTE after THR or TKR

The recommended dose is one 10 mg tablet once daily. XARELTO 10 mg may be taken with or without food. The initial dose should be taken within 6 to 10 hours after surgery, provided that hemostasis has been established. If hemostasis is not established, treatment should be delayed.

The duration of administration depends on the type of surgery:

- After elective THR surgery, patients should be administered XARELTO for 35 days.
- After elective TKR surgery, patients should be administered XARELTO for 14 days.

Treatment of VTE and Prevention of recurrent DVT and PE

XARELTO is NOT recommended as an alternative to unfractionated heparin in patients with acute pulmonary embolus who are hemodynamically unstable, or who may receive thrombolysis or pulmonary embolectomy, since the safety and efficacy of XARELTO have not been established in these clinical situations (see [INDICATIONS AND CLINICAL USE](#)).

The recommended dose for the initial treatment of acute DVT or PE is 15 mg twice daily (one tablet in the morning and one in the evening) for the first 3 weeks followed by 20 mg once daily for the continued treatment and prevention of recurrent DVT and PE.

Short duration of therapy (at least 3 months) should be considered in patients with DVT or PE provoked by major transient risk factors (e.g. recent major surgery or trauma). The duration of therapy should be individualised after careful assessment of the treatment benefit against the risk for bleeding.

Following completion of at least 6 months treatment for DVT or PE, the recommended dose for prevention of recurrent DVT and PE is 20 mg or 10mg once daily based on an individual assessment of the risk of recurrent DVT and PE against the risk for bleeding. For example, in patients in whom the risk of recurrent DVT or PE is considered high, such as those with complicated comorbidities who are at high risk of VTE recurrence, a dose of 20mg should be considered.

Longer duration of therapy should be considered in patients with DVT or PE provoked by permanent risk factors, unprovoked DVT or PE, or a history of recurrent DVT or PE.

The recommended maximum daily dose is 30 mg during the first 3 weeks of treatment and 20 mg thereafter.

XARELTO 15 mg and 20 mg tablets should be taken with food. XARELTO 10 mg tablets may be taken with or without food.

Prevention of Stroke and Systemic Embolism in Patients with Atrial Fibrillation

The recommended dose is one 20 mg tablet of XARELTO taken once daily with food (see [ACTION AND CLINICAL PHARMACOLOGY – Pharmacokinetics, Absorption](#)).

For patients with moderate renal impairment (CrCl 30 – 49 mL/min), the recommended dose is 15 mg once daily with food (see [Renal Impairment](#) below).

The recommended maximum daily dose is 20 mg.

Prevention of Stroke, Myocardial Infarction, Cardiovascular Death, Acute Limb Ischemia and Mortality in Patients with CAD with or without PAD.

The recommended vascular protection regimen for patients with CAD with or without PAD is one tablet of 2.5 mg XARELTO twice daily, one of which in combination with a once daily dose of 75 mg - 100 mg ASA. XARELTO 2.5 mg tablets may be taken with or without food.

Treatment should be continued long term provided the benefit outweighs the risk.

In patients with CAD with or without PAD, XARELTO 2.5 mg twice daily is not indicated in combination with dual antiplatelet therapy.

Administration of Crushed Tablets:

For patients who are unable to swallow whole tablets, XARELTO tablets may be crushed and mixed with applesauce immediately prior to use and administered orally. After the administration of a crushed XARELTO 15 mg or 20 mg tablet, the dose should be immediately followed by food.

A crushed XARELTO tablet may be also administered via nasogastric (NG) tube. After confirming gastric placement of the NG tube, the crushed tablet should be suspended in 50 mL of water and administered via the NG tube after which it should be flushed with water. Because rivaroxaban absorption is dependent on the site of drug release in the GI tract, avoid administration of XARELTO distal to the stomach as this can result in reduced absorption and therefore reduced drug exposure. After the administration of a crushed XARELTO 15 mg or 20 mg tablet, the dose should then be immediately followed by enteral feeding (**ACTION AND CLINICAL PHARMACOLOGY - Pharmacokinetics, Absorption**).

An *in vitro* compatibility study indicated that there is no adsorption of rivaroxaban from a water suspension of a crushed XARELTO tablet to PVC or silicone nasogastric (NG) tubing.

No studies were conducted to support the crushing and administration of crushed XARELTO 2.5 mg tablets and crushed ASA tablets together either as a mixture with applesauce or as a mixture administered via NG tube.

Acute myocardial infarction (AMI): Consideration should be given to discontinuing XARELTO in the setting of acute myocardial infarction should the treatment of myocardial infarction involve invasive procedures, such as percutaneous coronary revascularization, or coronary artery bypass surgery. Similar consideration should be given if thrombolytic therapy is to be initiated, because bleeding risk may increase. Patients with acute myocardial infarction should be treated according to current clinical guidelines. In this setting, XARELTO may be resumed, when deemed clinically appropriate, for the prevention of stroke and systemic embolism upon completion of these revascularization procedures.

Concomitant use of ASA or clopidogrel with XARELTO in patients with atrial fibrillation increases the risk of bleeding. Concomitant use of ASA or other antiplatelet agents based on medical need to prevent myocardial infarction should be undertaken with caution. Close clinical surveillance is recommended.

Other situations requiring thrombolytic therapy: XARELTO should be discontinued in situations such as acute ischemic stroke where current clinical practice calls for administering thrombolytic therapy. XARELTO treatment may be subsequently resumed as soon as is deemed clinically appropriate. Measurement of a PT time, in seconds, using the Neoplastin reagent, may inform therapeutic decision-making (see **WARNINGS AND PRECAUTIONS – Monitoring and Laboratory Tests**).

Concomitant use of XARELTO 10 mg, 15 mg and 20 mg with antiplatelet agents: The concomitant use of XARELTO with antiplatelet agents increases the risk of bleeding (see **WARNINGS AND PRECAUTIONS – Bleeding**). If concomitant antiplatelet therapy is contemplated with XARELTO 10 mg, 15 mg, and 20 mg, a careful assessment of the potential risks should be made against potential benefits, weighing risk of increased bleeding against expected benefit.

Patients with nonvalvular atrial fibrillation who undergo PCI with stent placement:

Patients with nonvalvular atrial fibrillation who undergo PCI with stent placement should receive a reduced dose of 15 mg XARELTO once daily (or 10 mg XARELTO once daily for patients with moderate renal impairment [CrCl 30 – 49 mL/min]) in combination with a P2Y₁₂ inhibitor (eg, clopidogrel). This treatment regimen is recommended for a maximum of 12 months after PCI with stent placement (see [ACTION AND CLINICAL PHARMACOLOGY – Pharmacodynamics, *Patients with nonvalvular atrial fibrillation who undergo PCI with stent placement*](#)). After completion of the antiplatelet therapy, rivaroxaban dosage should be changed to the standard dose for patients with atrial fibrillation.

Cardioversion:

Patients can be maintained on XARELTO while being cardioverted (see [ACTION AND CLINICAL PHARMACOLOGY, Pharmacodynamics, *Patients undergoing cardioversion*](#)).

Hepatic Impairment

XARELTO is contraindicated in patients with hepatic disease (including Child-Pugh Class B and C) associated with coagulopathy, and having clinically relevant bleeding risk. Patients with severe hepatic impairment or chronic hepatic disease were excluded from pivotal clinical trials.

The limited clinical data for patients with moderate hepatic impairment indicate a significant increase in the pharmacological activity. XARELTO should be used with caution in these patients (see [CONTRAINDICATIONS – WARNINGS AND PRECAUTIONS – Hepatic Impairment](#), and [ACTION AND CLINICAL PHARMACOLOGY – *Hepatic Insufficiency*](#)).

The limited data available for patients with mild hepatic impairment without coagulopathy indicate that there is no difference in pharmacodynamic response or pharmacokinetics as compared to healthy subjects.

Renal Impairment

Table 12 – Dosage and Administration for Patients According to Renal Function

Indication	Creatinine Clearance (CrCl)				
	Normal >80 mL/min	Mild 50-80 mL/min	Moderate 30-49 mL/min	Severe* 15 - < 30 mL/min	< 15 mL/min
Prevention of VTE After THR or TKR	10 mg od			10 mg od	XARELTO is not recommended
Treatment of VTE and Prevention of Recurrent DVT and PE	15 mg bid for 3 weeks, followed by 20 mg od			15 mg bid for 3 weeks, followed by 20 mg od	
Prevention of recurrent DVT and PE following completion of at least 6 months treatment	10 mg od or 20 mg od			10 mg od or 20 mg od	
Prevention of Stroke and Systemic Embolism in Patients with Atrial Fibrillation	20 mg od		15 mg od	15 mg od	
Prevention of Stroke, CV Death, MI, and Prevention of ALI and Mortality in Patients with CAD with or without PAD	2.5 mg bid + ASA 75 mg - 100 mg od			2.5 mg bid + ASA 75 mg - 100 mg od	

od=once daily, bid=twice daily

*must be used with caution

XARELTO should be used with caution in patients receiving other drugs which increase rivaroxaban plasma concentrations. Physicians should consider the benefit/risk of anticoagulant therapy before administering XARELTO to patients with moderate renal impairment with a creatinine clearance close to the severe renal impairment category (CrCl <30 mL/min) or with a potential to have deterioration of renal function during therapy. Renal function should be followed carefully in these patients (see **WARNINGS AND PRECAUTIONS – Renal Impairment**, and **DRUG INTERACTIONS – Drug-Drug Interactions**).

In patients with severe renal impairment (CrCl 15 - <30 mL/min), rivaroxaban plasma levels may be significantly elevated compared to healthy volunteers (1.6-fold on average) which may lead to an increased bleeding risk. Due to limited clinical data, XARELTO must be used with caution in these patients. No clinical data are available for patients with CrCl <15 mL/min. Use is not recommended in patients with CrCL <15ml/min. Patients who develop acute renal failure while on XARELTO should discontinue such treatment.

XARELTO 15 mg and 20 mg tablets should be taken with food (see **ACTION AND CLINICAL PHARMACOLOGY – Pharmacokinetics, Absorption**).

Gender, Race, or Body Weight

No dose adjustment is required (see **ACTION AND CLINICAL PHARMACOLOGY – Gender, Race, and Different Weight Categories**).

Geriatrics (>65 years of age)

No dose adjustment is generally required for the elderly. Increasing age may be associated with declining renal function (see **WARNINGS AND PRECAUTIONS – Renal Impairment**, and **DOSAGE AND ADMINISTRATION – Renal Impairment**).

Pediatrics (<18 years of age)

The safety and efficacy of XARELTO have not been established in children less than 18 years of age; therefore, XARELTO is not recommended in this patient population.

Switching from Parenteral Anticoagulants to XARELTO

XARELTO can be started when the infusion of full-dose intravenous heparin is stopped or 0 to 2 hours before the next scheduled injection of full-dose subcutaneous low-molecular-weight heparin (LMWH) or fondaparinux. In patients receiving prophylactic heparin, LMWH or fondaparinux, XARELTO can be started 6 or more hours after the last prophylactic dose.

Switching from XARELTO to Parenteral Anticoagulants

Discontinue XARELTO and give the first dose of parenteral anticoagulant at the time that the next XARELTO dose was scheduled to be taken.

Switching from Vitamin K Antagonists (VKA) to XARELTO

To switch from a VKA to XARELTO, stop the VKA and determine the INR. If the INR is ≤ 2.5 , start XARELTO at the usual dose. If the INR is > 2.5 , delay the start of XARELTO until the INR is ≤ 2.5 (see **Considerations for INR Monitoring of VKA Activity during Concomitant XARELTO Therapy**).

Switching from XARELTO to a VKA

As with any short-acting anticoagulant, there is a potential for inadequate anticoagulation when transitioning from XARELTO to a VKA. It is important to maintain an adequate level of anticoagulation when transitioning patients from one anticoagulant to another.

XARELTO should be continued concurrently with the VKA until the INR is ≥ 2.0 . For the first 2 days of the conversion period, the VKA can be given in the usual starting doses without INR testing (see **Considerations for INR Monitoring of VKA Activity during Concomitant XARELTO Therapy**). Thereafter, while on concomitant therapy, the INR should be tested just prior to the next dose of XARELTO, as appropriate. XARELTO can be discontinued once the INR is >2.0 . Once XARELTO is discontinued, INR testing may be done at least 24 hours after the last dose of XARELTO, and should then reliably reflect the anticoagulant effect of the VKA.

Considerations for INR Monitoring of VKA Activity during Concomitant XARELTO Therapy

In general, after starting VKA therapy, the initial anticoagulant effect is not readily apparent for at least 2 days, while the full therapeutic effect is achieved in 5-7 days. Consequently, INR monitoring in the first 2 days after starting a VKA is rarely necessary. Likewise, the INR may remain increased for a number of days after stopping VKA therapy.

Although XARELTO therapy will lead to an elevated INR, depending on the timing of the measurement (see **ACTION AND CLINICAL PHARMACOLOGY – Pharmacodynamics**), the INR is not a valid measure to assess the anticoagulant activity of XARELTO. The INR is only calibrated and validated for VKA and should not be used for any other anticoagulant, including XARELTO.

When switching patients from XARELTO to a VKA, the INR should only be used to assess the anticoagulant effect of the VKA, and not that of XARELTO. Therefore, while patients are concurrently receiving XARELTO and VKA therapy, if the INR is to be tested, it should not be before 24 hours after the previous dose of XARELTO, and should be just prior to the next dose of XARELTO, since at this time the remaining XARELTO concentration in the circulation is too low to have a clinically important effect on the INR. If INR testing is done earlier than just prior to the next dose of XARELTO, the reported INR will not reflect the anticoagulation effect of the VKA only, because XARELTO use may also affect the INR, leading to aberrant readings (see **ACTION AND CLINICAL PHARMACOLOGY – Pharmacodynamics**).

Missed Dose

It is essential to adhere to the dosage schedule provided.

- XARELTO 2.5 mg tablets taken **twice** a day
If a 2.5 mg twice daily dose is missed the patient should continue with the regular 2.5 mg XARELTO dose as recommended at the next scheduled time.
- XARELTO 10 mg, 15 mg, or 20 mg tablets taken **once** a day:
If a dose is missed, the patient should take XARELTO immediately and continue on the following day with the once daily intake as before. A double dose should not be taken to make up for a missed tablet.
- XARELTO 15 mg taken **twice** a day:
If a dose is missed during the 15 mg twice daily treatment phase the patient should take the next dose immediately to ensure the intake of 30 mg total dose per day. In this case two 15 mg tablets may be taken at once. The following day the patient should continue with the regular 15 mg twice daily intake schedule as recommended.

OVERDOSAGE

For management of suspected drug overdose, contact your regional Poison Control Centre.

Overdose following administration of XARELTO (rivaroxaban) may lead to hemorrhagic complications due to its pharmacodynamic properties.

Rare cases of overdose up to 600 mg have been reported without bleeding complications or other adverse reactions. No further increase in average plasma exposure is expected due to limited absorption at supratherapeutic doses of 50 mg or above because of a solubility ceiling effect.

A specific antidote for XARELTO is not available. The use of activated charcoal to reduce absorption in case of XARELTO overdose may be considered. Administration of activated charcoal up to 8 hours after overdose may reduce the absorption of XARELTO.

Due to the high plasma protein binding, XARELTO is not expected to be removed by dialysis (see **ACTION AND CLINICAL PHARMACOLOGY – Pharmacokinetics, Distribution**).

Management of Bleeding

In the event of hemorrhagic complications in a patient receiving XARELTO, treatment should be temporarily discontinued, and the source of bleeding investigated. XARELTO has a half-life of approximately 5 to 13 hours (see **ACTION AND CLINICAL PHARMACOLOGY – Pharmacokinetics**). Consideration should be given to the resumption of antithrombotic therapy when clinically appropriate to adequately control risk of underlying thrombosis.

Management of bleeding should be individualised according to the severity and location of the hemorrhage. Appropriate symptomatic treatment should be used as needed, such as mechanical compression (eg, for severe epistaxis), surgical hemostasis with bleeding control procedures, fluid replacement and hemodynamic support, blood products (packed red cells or fresh frozen plasma, depending on associated anemia or coagulopathy) or platelets.

If bleeding cannot be controlled by the above measures, consider administration of one of the following procoagulants:

- activated prothrombin complex concentrate (APCC), eg., FEIBA
- prothrombin complex concentrate (PCC)
- recombinant Factor-VIIa (rFVIIa)

However, there is currently only very limited experience with the use of these products in individuals receiving XARELTO.

In a randomized, double-blind, placebo-controlled study, a non-activated prothrombin complex concentrate (PCC) given to 6 healthy male subjects who had previously received XARELTO, completely reversed its anticoagulant effect within 15 minutes, based on coagulation tests. Although this study may have important clinical implications, this effect of PCC has not yet been confirmed in patients with active bleeding who have been previously treated with XARELTO.

Protamine sulfate and vitamin K are not expected to affect the anticoagulant activity of XARELTO. There is limited experience with tranexamic acid and no experience with aminocaproic acid and aprotinin in individuals receiving XARELTO. There is neither scientific rationale for benefit or experience with the systemic hemostatic desmopressin in individuals receiving XARELTO.

The prothrombin time (PT), measured in seconds, is influenced by XARELTO in a dose-dependent way with a close correlation to plasma concentrations if the Neoplastin[®] reagent is used. In patients who are bleeding, measuring the PT (Neoplastin[®] reagent) may be useful to assist in determining an excess of anticoagulant activity. INR should **NOT** be used to assess the anticoagulant effect of XARELTO (see **WARNINGS AND PRECAUTIONS – Monitoring and Laboratory Tests**, and **ACTION AND CLINICAL PHARMACOLOGY – Pharmacodynamics**).

ACTION AND CLINICAL PHARMACOLOGY

Mechanism of Action

XARELTO (rivaroxaban) is a highly selective, direct, antithrombin independent Factor-Xa inhibitor with high oral bioavailability.

Activation of Factor-X to Factor-Xa (FXa) via the intrinsic and extrinsic pathway plays a central role in the cascade of blood coagulation. FXa directly converts prothrombin to thrombin through the prothrombinase complex and, ultimately, this reaction leads to fibrin clot formation and activation of platelets by thrombin. One molecule of FXa is able to generate more than 1000 molecules of thrombin due to the amplification nature of the coagulation cascade. In addition, the reaction rate of prothrombinase-bound FXa increases 300,000-fold compared to that of free FXa and causes an explosive burst of thrombin generation. Selective inhibitors of FXa can terminate the amplified burst of thrombin generation, thereby diminishing thrombin-mediated activation of coagulation.

Pharmacodynamics

There is a clear correlation between plasma rivaroxaban concentration and the degree of anticoagulant effect. The maximal effect (E_{max}) of rivaroxaban on pharmacodynamic parameters occurs at the same time as C_{max} .

- A dose-dependent inhibition of Factor-Xa (FXa) activity was observed over the complete dose range closely following the pharmacokinetic profiles which provides the ‘proof of mechanism’ in humans. Inhibition of FXa activity versus rivaroxaban plasma concentration follows a maximum effect (E_{max}) model. There is a close correlation between FXa inhibition and plasma concentrations with an r value of 0.97.

FXa assay tests require calibration and should not be used unless rivaroxaban-specific calibrators and controls are available.

- Prothrombin time (PT), measured in seconds, is influenced by rivaroxaban in a dose-dependent way with a close correlation to plasma concentrations ($r = 0.98$) if the Neoplastin[®] reagent is used. Other reagents would provide different results. Although XARELTO therapy will lead to an elevated INR, depending on the timing of the measurement, the INR is not a valid measure to assess the anticoagulant activity of XARELTO. The INR is only calibrated and validated for VKA and should not be used for any other anticoagulant (see **WARNINGS AND PRECAUTIONS – Monitoring and Laboratory Tests**).

In patients who are bleeding, measuring the PT (Neoplastin[®] reagent) may be useful to assist in determining an excess of anticoagulant activity (see **WARNINGS AND PRECAUTIONS – Monitoring and Laboratory Tests**).

Figure 1 and Figure 2 below show the relative measured effects of rivaroxaban 20 mg once daily for the PT test using the Neoplastin[®] reagent (Figure 1) and that expressed by the INR (Figure 2).

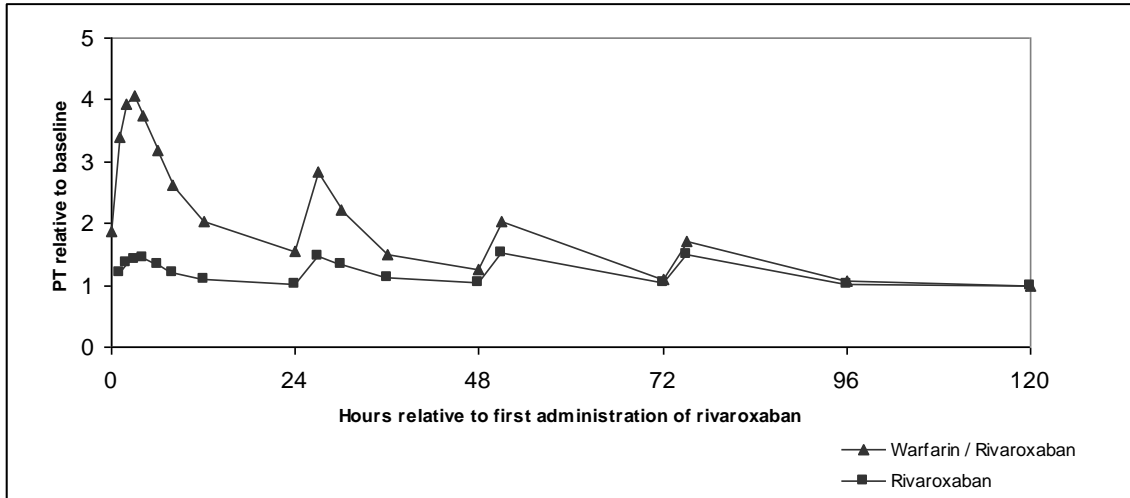

Figure 1: PT Prolongation (Neoplastin® reagent): Relative prolongation expressed as median of ratio to baseline with warfarin / rivaroxaban treatment and rivaroxaban alone, following last day of warfarin (Day -1) and 4 days of 20 mg rivaroxaban od, PD set, n=84

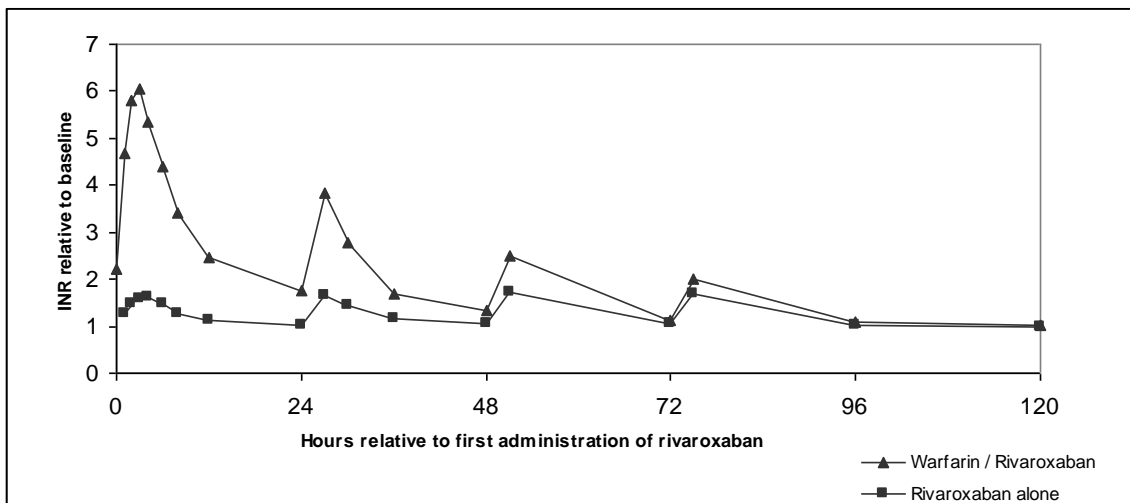

Figure 2: INR prolongation: Relative prolongation expressed as median of ratio to baseline with warfarin/ rivaroxaban treatment and rivaroxaban alone, following last day of warfarin (Day -1) and 4 days of 20 mg rivaroxaban od, PK/PD set, n=84

The usual expected effect of XARELTO on PT when the Neoplastin® reagent is used is shown in [Table 13](#) below. The dose of 2.5 mg XARELTO is expected to only minimally affect PT.

Table 13 – PT (Neoplastin® reagent) by Indication, Following XARELTO Administration

Indication	XARELTO Dosage	Plasma concentration C _{max} (µg/ L)	Plasma concentration C _{trough} (µg/L)	Range of (5/95 percentile) PT (Neoplastin®) C _{max}	Range of (5/95 percentile) PT (Neoplastin®) C _{trough}
Prevention of VTE After THR or TKR	10 mg od	101 (7 – 273) ^a	14 (4 – 51) ^c	13 to 25 seconds ^a	12-17 seconds ^c
Treatment of VTE and Prevention of Recurrent DVT and PE	15 mg bid	---	---	17 to 32 seconds ^a	14–24 seconds ^c
	20 mg od	215 (22– 535) ^a	32 (6–239) ^d	15 to 30 seconds ^a	13–20 seconds ^d
Prevention of Stroke in Patients with Atrial Fibrillation	15 mg od	229 (178 – 313) ^b	57 (18 – 136) ^c	10 to 50 seconds ^b	12–26 seconds ^c
	20 mg od	249 (184 – 343) ^b	44 (12 – 137) ^e	14 to 40 seconds ^b	11–26 seconds ^c

a 2 to 4 hours after drug administration (t_{max})

b 1 to 4 hours after drug administration (t_{max})

c 8 to 16 hours after drug administration (t_{min})

d 18 to 30 hours after drug administration (t_{min})

e 16 to 32 hours after drug administration (t_{min})

- The activated partial thromboplastin time (aPTT) is prolonged dose-dependently; however, the slope is rather flat and does not allow a sufficient discrimination at the relevant plasma concentrations. Therefore, aPTT is not considered to be adequate for following the pharmacodynamic effects. The r value for aPTT is 0.99.
- Heptest® is prolonged dose-dependently and correlates closely with plasma concentrations, following a curvilinear model. Despite the r value of 0.99 for the relation to plasma concentrations, the Heptest® is not considered optimal to assess the pharmacodynamic effects due to the curvilinear relationship.

QT Prolongation

No QTc prolonging effects were observed in healthy men and women older than 50 years. The treatment difference in QTcF 3 hours post-dose in comparison to placebo as well as QTcF, QTcI and QT analyses at the time of t_{max} and for post-dose changes in mean and maximum QTcF did not show any dose-related QTcF prolongation at both the 45 mg and the 15 mg dose of rivaroxaban. All changes in LS-means, including their 95% CI, were below 5 milliseconds.

Patients undergoing cardioversion

A prospective, randomized, open-label, multicenter, exploratory study with blinded endpoint evaluation (X-VerT) was conducted in 1504 patients with non-valvular atrial fibrillation scheduled for cardioversion to compare rivaroxaban with dose-adjusted VKA (randomized 2:1). The rate of stroke occurring within 42 days of cardioversion was low and similar across treatment groups, i.e., rivaroxaban (0.20%) and VKA (0.41%). The rate of major bleeding was also low and similar across treatment groups, i.e., rivaroxaban (0.61%) and VKA (0.80%).

Patients with nonvalvular atrial fibrillation who undergo PCI with stent placement

In a randomized, open label, multicentre study (PIONEER AF-PCI) in patients with nonvalvular atrial fibrillation who underwent PCI with stent placement for primary atherosclerotic disease, the 12-month safety of two antithrombotic regimens was compared. One group of 696 patients received rivaroxaban 15 mg o.d. (10 mg o.d. in patients with CrCl 30-49 mL/min) in combination with a P2Y₁₂ inhibitor (eg, clopidogrel), while a second group of 697 patients received dose-adjusted VKA plus DAPT. Patients with a history of stroke or TIA were excluded from the trial.

The primary safety endpoint, clinically significant bleeding events [a composite of TIMI major bleeding, TIMI minor bleeding and Bleeding Requiring Medical Attention (BRMA)] occurred in 109 patients (15.7%) on the rivaroxaban regimen and in 167 patients (24.0%) on the VKA regimen (HR 0.59; 95% CI 0.47-0.76; p<0.001). This difference in bleeding risk was primarily a result of significantly fewer BRMA events in patients on the rivaroxaban regimen. While a consistent treatment effect for all 3 components of the composite was observed, the low number of TIMI major and TIMI minor bleeding events during the trial prevented the demonstration of a significant difference between the two regimens for these endpoints. The secondary endpoint, a composite of CV death, MI or stroke, occurred in 41 patients (5.9%) on rivaroxaban and in 36 patients (5.2%) on VKA; stent thrombosis occurred in 5 patients on rivaroxaban and in 4 patients on VKA. The study was not designed to compare efficacy between the treatment arms, preventing any conclusions regarding efficacy.

Pharmacokinetics

Absorption

The absolute bioavailability of rivaroxaban is approximately 100% for doses up to 10 mg. Rivaroxaban is rapidly absorbed with maximum concentrations (C_{max}) appearing 2 to 4 hours after tablet intake.

Intake with food does not affect rivaroxaban AUC or C_{max} for doses up to 10 mg. XARELTO 2.5 mg and 10 mg tablets can be taken with or without food. Due to reduced extent of absorption an oral bioavailability of 66% was determined for the 20 mg tablet under fasting conditions. When XARELTO 20 mg tablets are taken together with food, increases in mean AUC by 39% were observed when compared to tablet intake under fasting conditions, indicating almost complete absorption and high oral bioavailability.

The bioavailability of rivaroxaban 10 mg, 15 mg and 20 mg tablets under fed conditions, and 2.5 mg and 10 mg tablets under fasted conditions, demonstrated dose-proportionality. XARELTO 15 mg and 20 mg tablets should be taken with food (see **DOSAGE AND ADMINISTRATION**, and **DETAILED PHARMACOLOGY - Absorption and Bioavailability**).

Rivaroxaban pharmacokinetic parameters behave in a linear fashion; no evidence of undue accumulation beyond steady-state was seen after multiple doses.

Interindividual variability (CV%) of rivaroxaban pharmacokinetics ranges from 30% to 40%. This may be increased on the day of surgery and on the following day when interindividual variability is 70%.

Table 14 – Summary of PK Parameters After Oral Administration of 10 mg of Rivaroxaban in Humans

	C_{max} [µg/L]	t_{1/2} [h]	AUC [µg*h/L]	Clearance, Urinary Excretion	Volume of Distribution
Healthy (Young) Subjects	~114 ^a	5-9	~817	CL _{sys} = ~10 L/h CL _R = 3 – 4 L/h Ae _{ur} = 30% - 40%	V _{ss} = ~50 L
Patients	~125	7-11	~1170	N/A (no IV data) ^b Ae _{ur} = 22%	N/A (no IV data)

a = 2 – 4 hours after drug administration (t_{max})

b = not available

AUC = area under the plasma-concentration time curve; Ae_{ur} = amount of drug excreted unchanged into urine; CL_{sys} = systemic clearance (after intravenous administration); CL_R = renal clearance; C_{max} = maximum plasma concentration; t_{1/2} = terminal elimination half-life; t_{max} = time to reach C_{max}; V_{ss} = volume of distribution at steady state

Absorption of rivaroxaban is dependent on the site of drug release in the GI tract. A 29% and 56% decrease in AUC and C_{max} compared to orally ingested tablet was reported when rivaroxaban granulate is released in the proximal small intestine. Exposure is further reduced when drug is released in the distal small intestine, or ascending colon. Avoid administration of rivaroxaban distal to the stomach as this can result in reduced absorption and related drug exposure.

In an open-label, randomized, 3-period, 3-treatment crossover comparative bioavailability study conducted in 44 healthy male and female subjects, the bioavailability (AUC_T and C_{max}) of rivaroxaban following a single 20 mg dose as a crushed 20 mg tablet mixed in applesauce and administered orally, or as a crushed 20 mg tablet suspended in water and administered via NG tube was comparable to a whole 20 mg tablet administered orally. Each rivaroxaban treatment was taken with a standardized liquid meal. Given, the predictable, dose-proportional pharmacokinetic profile of rivaroxaban, the bioavailability results from this study are likely applicable to lower rivaroxaban doses.

Distribution

Plasma protein binding in humans is high at approximately 92% to 95%, with serum albumin being the main binding component. The volume of distribution is moderate with V_{ss} being approximately 50 L.

Metabolism

Rivaroxaban is eliminated by metabolic degradation (approximately 2/3 of the administered dose) as well as by direct renal excretion of unchanged compound (approximately 1/3). Rivaroxaban is metabolized via CYP 3A4, CYP 2J2, and CYP-independent mechanisms. Oxidative degradation of the morpholinone moiety and hydrolysis of the amide bonds are the major sites of biotransformation.

Excretion

Rivaroxaban and metabolites have a dual route of elimination (via renal and fecal routes).

The clearance and excretion of rivaroxaban are as follows:

- 1/3 of the active drug is cleared as unchanged drug by the kidneys

- 1/3 of the active drug is metabolized to inactive metabolites and then excreted by the kidneys
- 1/3 of the active drug is metabolized to inactive metabolites and then excreted by the fecal route

Based on in vitro investigations, rivaroxaban is a substrate of the transporter proteins P-gp (P-glycoprotein) and BCRP (breast cancer resistance protein).

Unchanged rivaroxaban is the most important compound in human plasma with no major or active circulating metabolites being present. With a systemic clearance of about 10 L/h rivaroxaban can be classified as low-clearance drug. Elimination of rivaroxaban from plasma occurred with terminal half-lives of 5 to 9 hours in young individuals and with terminal half-lives of 11 to 13 hours in the elderly.

Geriatrics (>65 years of age)

Clinical studies have been conducted in older ages, with results of prolonged terminal half-lives (11 to 13 hours in elderly versus 5 to 9 hours in young subjects) accompanied by increases of XARELTO exposure (approximately 50%) compared to young healthy subjects. This difference may be due to reduced renal function in the elderly (see **CONTRAINDICATIONS, WARNINGS AND PRECAUTIONS – Renal Impairment**, and **DOSAGE AND ADMINISTRATION – Renal Impairment**).

Gender

There were no clinically relevant differences in pharmacokinetics between male and female patients (see **DETAILED PHARMACOLOGY - Gender**).

Race

No clinically relevant interethnic differences among Caucasian, African-American, Hispanic, Japanese or Chinese patients were observed regarding pharmacokinetics and pharmacodynamics (see **DETAILED PHARMACOLOGY – Race**).

Hepatic Insufficiency

A Phase I study investigated the influence of impaired hepatic function in cirrhotic patients (Child-Pugh Class A or B, number of patients 8 per group) on the pharmacodynamics and pharmacokinetics of a single dose of rivaroxaban.

In patients with mild hepatic impairment (Child-Pugh Class A), there was no difference as compared to healthy volunteers with respect to either pharmacodynamics (inhibition of Factor-Xa activity [1.08-fold for AUC and 0.98-fold for E_{max}]), prolongation of prothrombin time (1.02-fold for AUC and 1.06-fold for E_{max}), or pharmacokinetics (both total and unbound AUC [1.15 for total and 0.91-fold increase for unbound] and C_{max} [0.97 for total and 0.78-fold for unbound]).

Child-Pugh Class B patients had lower baseline Factor-Xa activity levels (0.64 U/mL) compared to healthy subjects and Child-Pugh Class A patients (0.85 U/mL, for both patient populations). Inhibition of Factor-Xa activity was more pronounced in Child-Pugh Class B patients compared to both healthy subjects and Child-Pugh Class A patients. The increase of inhibition was 2.6-fold $AUC_{(0-t_n)}$ and 1.2-fold maximal effect (E_{max}). The group difference was statistically significant, both for $AUC_{(0-t_n)}$ ($P < 0.01$) as well as for E_{max} ($P < 0.05$) of inhibition of Factor-Xa activity. In

line with these results, a relevant difference in prolongation of PT was observed between healthy subjects and Child-Pugh Class B patients. The increase of prolongation was 2.1-fold ($AUC_{(0-t_n)}$) and 1.4-fold (E_{max}). A statistically significant group-difference was observed for $AUC_{(0-t_n)}$ ($P < 0.0004$) as well as E_{max} ($P < 0.0001$).

Pharmacokinetic parameters also indicated a significant increase in Child-Pugh Class B patients as compared to healthy volunteers both on AUC pharmacokinetics (both total and unbound AUC [2.27-fold for total and 2.57-fold increase for unbound]) and C_{max} (1.27-fold for total and 1.38-fold for unbound).

A PK/PD analysis showed that the slope of the prothrombin time/plasma concentration correlation is increased by more than 2-fold for Child-Pugh Class B patients as compared to healthy volunteers. Since the global clotting test PT assesses the extrinsic pathway that is comprised of the coagulation Factor-VII, Factor-X, Factor-V, Factor-II, and Factor-I which are synthesized in the liver, impaired liver function can also result in prolongations of PT in the absence of anticoagulant therapy.

The PK/PD changes observed in Child-Pugh Class B patients are markers for the severity of the underlying hepatic disease which is expected to lead to a subsequent increased bleeding risk in this patient group.

XARELTO is contraindicated in patients with hepatic disease (including Child-Pugh Class B and C) associated with coagulopathy, and having clinically relevant bleeding risk (see **CONTRAINDICATIONS**, and **WARNINGS AND PRECAUTIONS – Hepatic Impairment**).

Renal Insufficiency

As active rivaroxaban is partially cleared via the kidneys (30% to 40% of the dose), there is a direct but moderate correlation of systemic exposure to rivaroxaban with degree of renal impairment.

In a Phase I study, following oral single dosing with rivaroxaban 10 mg in subjects with mild ($CrCl$ 50 – 79 mL/min), moderate ($CrCl$ 30 – 49 mL/min), or severe ($CrCl$ 15 – 29 mL/min) renal impairment, rivaroxaban plasma concentrations (AUC) were increased 1.4-, 1.5-, and 1.6-fold, respectively compared to healthy subjects with normal renal function ($CrCl \geq 80$ mL/min).

The overall inhibition of Factor-Xa activity ($AUC_{(0-48h)}$ of effect versus time) was increased in these groups by a factor of 1.5, 1.9, and 2.0, respectively. The relative prolongation of prothrombin time (PT) was also affected by renal impairment and showed even more pronounced effects. $AUC_{(0-48h)}$ of effect versus time was increased by a factor of 1.3, 2.2, and 2.4, respectively.

In Phase II, rivaroxaban plasma concentrations (AUC) were increased 1.2- and 1.5-fold in subjects with mild and moderate renal impairment respectively compared to healthy subjects with normal renal function and the peak inhibition of Factor-Xa activity ($AUC_{(0-48h)}$ of effect versus time) was increased in these groups by a factor of 1.0 and 1.3 respectively. In a pooled analysis of Phase III THR or TKR subjects with mild and moderate renal impairment, the peak PT was increased by 1.0-, and 1.1-fold compared to subjects with normal renal function.

In Phase II (VTE treatment), rivaroxaban plasma concentrations (AUC) were 1.3- and 1.5-fold in subjects with mild and moderate renal impairment, respectively, compared to subjects with normal renal function. In phase III subjects (VTE treatment) with mild renal impairment, the peak PT was increased by 1.1-fold, and 1.2-fold for moderate renal impairment compared to subjects with normal renal function.

In patients with atrial fibrillation evaluated in Phase III, the peak PT was increased by 1.2-fold for both mild and moderate renal impairment compared to subjects with normal renal function.

There was no evidence of substantial drug accumulation in patients with mild or moderate renal impairment.

Different Weight Categories

Extremes in body weight (<50 kg or >120 kg) of patients taking a 10 mg tablet caused less than a 25% change in the plasma concentration of XARELTO (see [DETAILED PHARMACOLOGY – Body Weight](#)).

STORAGE AND STABILITY

Store at 15°C to 30°C.

Store in a safe place out of the reach of children.

DOSAGE FORMS, COMPOSITION AND PACKAGING

Excipients

Cellulose microcrystalline, croscarmellose sodium, hypromellose 5 cP, lactose monohydrate, magnesium stearate, sodium lauryl sulfate

Film-coating

Ferric oxide red (10 mg, 15 mg, 20 mg) or ferric oxide yellow (2.5 mg), hypromellose 15 cP, polyethylene glycol, titanium dioxide

2.5 mg Tablets:

Film-coated, round, biconvex, light yellow immediate release tablets of 6 mm diameter for oral use.

Each tablet has the Bayer Cross on one side and 2.5 and a triangle on the other side.

XARELTO (rivaroxaban) 2.5 mg tablets are supplied in blisters of 14 (physician sample), and HDPE bottles of 100.

10 mg Tablets:

Film-coated, round, biconvex, light red immediate release tablets of 6 mm diameter for oral use.

Each tablet has the Bayer Cross on one side and 10 and a triangle on the other side.

XARELTO (rivaroxaban) 10 mg tablets are supplied in HDPE bottles of 50 and 120, and in blisters of 10, 30, and 100.

15 mg Tablets:

Film-coated, round, biconvex, red immediate release tablets of 6 mm diameter for oral use.

Each tablet has the Bayer Cross on one side and 15 and a triangle on the other side.

XARELTO tablets 15 mg are supplied in HDPE bottles of 90 and blisters of 28, 42 and 100.

20 mg Tablets:

Film-coated, round, biconvex, brown-red immediate release tablets of 6 mm diameter for oral use.

Each tablet has the Bayer Cross on one side and 20 and a triangle on the other side.

XARELTO tablets 20 mg are supplied in HDPE bottles of 90 and blisters of 28, 84 and 100.

Deep Vein Thrombosis (DVT)/Pulmonary Embolism (PE) Starter Pack:

XARELTO tablets are supplied in a 28-day starter blister pack containing 49 tablets: 42 tablets of 15 mg and 7 tablets of 20 mg. The Starter Pack includes 15 mg and 20 mg tablets.

PART II : SCIENTIFIC INFORMATION

PHARMACEUTICAL INFORMATION

Drug Substance

Common Name: Rivaroxaban
Chemical Name: 5-Chloro-N-({(5S)-2-oxo-3-[4-(3-oxo-4-morpholinyl)phenyl]-1,3-oxazolidin-5-yl}methyl)-2-thiophene-carboxamide

**Molecular Formula and
Molecular Mass:** C₁₉ H₁₈ Cl N₃ O₅ S
435.89

Structural Formula:

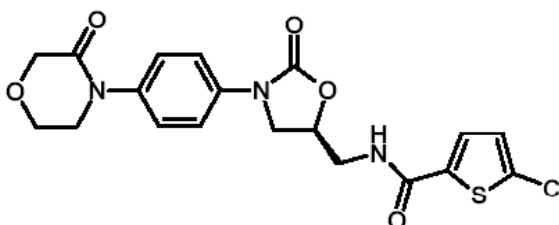

Physicochemical Properties: Rivaroxaban is a pure (S)-enantiomer. It is an odorless, nonhygroscopic, white to yellowish powder. Rivaroxaban is practically insoluble in water (7 mg/L, pure water) and remains so in aqueous acidic medium (5 mg/L, in 0.1 M and 0.01 M hydrochloric acid) or buffer systems, pH 3 to 9 (5 mg/L)

CLINICAL TRIALS

Prevention of VTE after THR or TKR

The pivotal studies were designed to demonstrate the efficacy of XARELTO (rivaroxaban) for the prevention of venous thromboembolic events (VTE), ie, proximal and distal deep vein thrombosis (DVT) and pulmonary embolism (PE) in patients undergoing elective total hip replacement (THR) or total knee replacement (TKR) surgery. A once daily dose of 10 mg was selected for all Phase III studies in the prevention of VTE in patients undergoing THR or TKR surgery, based on clinical data generated in Phase II studies. Over 9,500 patients (7,050 in THR surgery; 2,531 in TKR surgery) were studied in these controlled randomized double-blind studies (RECORD 1, 2, and 3).

Pivotal Studies

The RECORD 1 and 3 studies were multicenter, multinational, prospective, double-blind, double-dummy studies in patients randomized to XARELTO or to enoxaparin, see [Table 15](#). A non-inferiority was adopted with the pre-specification that, if non-inferiority was shown, a second analysis would be undertaken to determine if the efficacy of XARELTO was superior to that of enoxaparin. RECORD 1 was conducted in patients undergoing elective THR surgery while RECORD 3 was conducted in patients undergoing elective TKR surgery. In both studies, XARELTO 10 mg once daily started not earlier than 6 hours postoperatively was compared with an enoxaparin dosage regimen of 40 mg once daily started 12 hours preoperatively, as recommended in many countries worldwide. The dose of enoxaparin sodium approved for use in thromboprophylaxis in conjunction with elective THR or TKR surgery in Canada is subcutaneous 30 mg twice daily with the first dose to be administered 12 to 24 hours postoperatively. The primary endpoint was Total VTE a composite of any DVT (distal or proximal), nonfatal PE, or death from any cause. The main secondary endpoint was Major VTE, a composite endpoint comprising proximal DVT, nonfatal pulmonary embolism (PE), and VTE-related death. Other pre-specified secondary efficacy endpoints included the incidence of DVT (any thrombosis, including proximal and distal) and the incidence of symptomatic VTE.

Men and women of 18 years or older scheduled for elective surgery could be enrolled provided that they had no active or high risk of bleeding or other conditions contraindicating treatment with low-molecular-weight heparin, no significant liver disease, were not pregnant or breastfeeding women, or were not using HIV-protease inhibitors.

In RECORD 1 and 3, demographic and surgical characteristics were similar between the two groups except for a significantly larger number of females in RECORD 3 (XARELTO 70% and enoxaparin 66%, $P = 0.03$). The reasons for exclusion of patients from various analyses in both studies were also similar.

Table 15 – Summary of the Pivotal Studies for the Prevention of Venous Thromboembolic Events (VTE) in Patients Undergoing Elective Total Hip Replacement (THR) or Total Knee Replacement (TKR) Surgery

Study	Study Design	Treatment Regimen	Patient Populations
RECORD 1 ^a	THR patients prospectively randomized to XARELTO or enoxaparin; noninferiority, double-blind, double-dummy design; multinational study.	XARELTO 10 mg od oral for 35±4 days (first dose administered 6 to 8 h postoperatively) Enoxaparin 40 mg od SC for 36±4 days (first dose administered 12 h preoperatively)	Randomized 4541 (2266 XARELTO, 2275 enoxaparin) Safety Population 4433 (2209 XARELTO, 2224 enoxaparin) mITT 3153 (1595 XARELTO, 1558 enoxaparin) mITT (for Major VTE) 3364 (1686 XARELTO, 1678 enoxaparin) Per Protocol 3029 (1537 XARELTO, 1492 enoxaparin)
RECORD 3 ^a	TKR patients prospectively randomized to XARELTO or enoxaparin; noninferiority, double-blind, double-dummy design; multinational study.	XARELTO 10 mg od oral for 12±2 days (first dose administered 6 to 8 h postoperatively) Enoxaparin 40 mg od SC for 13±2 days (first dose administered 12 h preoperatively)	Randomized 2531 (1254 XARELTO, 1277 enoxaparin) Safety Population 2459 (1220 XARELTO, 1239 enoxaparin) mITT 1702 (824 XARELTO, 878 enoxaparin) mITT (for Major VTE) 1833 (908 XARELTO, 925 enoxaparin) Per Protocol 1631 (793 XARELTO, 838 enoxaparin)

a The mean age of patients in RECORD 1 and 3 was 63.2±11.4, and 67.6±9 years, respectively.

Safety population = The safety population comprised those patients who received at least 1 dose of study drug.

mITT = A subject was considered valid for the modified intent-to-treat (MITT) analysis if the subject was (1) valid for safety analysis; (2) had undergone the appropriate surgery; and (3) had an adequate assessment of thromboembolism.

mITT (for Major VTE) = A subject was valid for MITT analysis of major VTE, if the subject was (1) valid for safety analysis; (2) had undergone the appropriate surgery; and (3) had an adequate assessment of thromboembolism for major VTE.

Per Protocol = the per-protocol (PP) population was to include patients who were (1) valid for the MITT analysis; (2) had an adequate assessment of thromboembolism that, in case of a positive finding, was done not later than 36 h after stop of active study drug, in case of no finding, was done not later than 72 h after the end of active study drug; and (3) had no major protocol deviations.

Major VTE = composite of proximal DVT, nonfatal PE, or VTE-related death

od = once daily

SC = subcutaneous

The results of the non-inferiority analysis of Total VTE for RECORD 1 and 3 are presented in [Table 16](#). For the primary efficacy analysis, the difference between the incidences in the XARELTO group and the enoxaparin group were estimated, after stratification according to country using the Mantel-Haenszel weighting, and the corresponding asymptotic two-sided 95% confidence interval was determined. Tests for non-inferiority and superiority were both based on the 95% confidence interval. Non-inferiority was shown if the lower limit of the CI was above the pre-specified non-inferiority margin; -3.5% in RECORD 1 and -4% in RECORD 3.

Table 16 – RECORD 1 (THR) and RECORD 3 (TKR): Non-inferiority Analysis of Total VTE^a, the Primary Composite Efficacy Endpoint, and its Components –Per Protocol (PP)^b Population Through the Double-Blind Treatment Period

	RECORD 1 (THR)		RECORD 3 (TKR)	
	XARELTO 10 mg od N=1537 n (%)	Enoxaparin 40 mg od N=1492 n (%)	XARELTO 10 mg od N=793 n (%)	Enoxaparin 40 mg od N=838 n (%)
Total VTE^a (primary composite endpoint)	13 (0.9%)	50 (3.4%)	74 (9.3%)	152 (18.1%)
	Absolute Risk Reduction ^c 2.5% (1.5% to 3.6%; <i>P</i> <0.001)		Absolute Risk Reduction ^c 8.7% (5.4% to 12.0%; <i>P</i> <0.001)	
DVT (proximal and/or distal)	11 (0.7)	47 (3.2)	74 (9.3)	147 (17.5)
Nonfatal PE	2 (0.1)	1 (<0.1)	0	3 (0.4)
Death from all causes	1 (<0.1)	2 (0.1)	0	2 (0.2)

- a Total VTE = DVT (proximal and/or distal), nonfatal PE, or death from all causes
b PP = the per-protocol (PP) population was to include patients who were (1) valid for the MITT analysis; (2) had an adequate assessment of thromboembolism that, in case of a positive finding, was done not later than 36 h after stop of active study drug, in case of no finding, was done not later than 72 h after the end of active study drug; and (3) had no major protocol deviations
c Mantel-Haenszel Weighted Reduction to Enoxaparin (Non-inferiority was shown if the lower limit of the CI was above the pre-specified non-inferiority margin; -3.5% in RECORD 1 and -4% in RECORD 3)

In both pivotal studies, the per-protocol analysis for the primary endpoint showed that XARELTO 10 mg od/day (first dose 6 to 8 hours postoperatively) was not inferior to enoxaparin 40 mg/day (first dose 12 to 24 hours preoperatively).

Since non-inferiority was shown, a pre-specified superiority analysis was undertaken to determine if the efficacy of XARELTO was superior to that of enoxaparin in the modified intent-to-treat population (mITT). The superiority analysis of Total VTE and data for the main secondary endpoint (Major VTE) and other secondary endpoints for RECORD 1 and 3 are presented in [Table 17](#) and [Table 18](#), respectively.

Table 17 – RECORD 1 (THR): Superiority Analysis for Total VTE (Primary Composite Endpoint)^a, Major VTE (Main Secondary Endpoint)^b and Their Components, and Other Selected Efficacy Endpoints – Modified ITT^c (MITT) Population Through the Double-Blind Treatment Period

Parameter	XARELTO 10 mg		Enoxaparin 40 mg		Absolute Risk Reduction ^d % (95% CI)	P-Value	Relative Risk Reduction % (95% CI)	P-Value
	n/N	% (95% CI)	n/N	% (95% CI)				
Total VTE	18/1595	1.1% (0.7% to 1.8%)	58/1558	3.7% (2.8% to 4.8%)	2.6% (1.5% to 3.7%)	<0.001	70% (49%-82%)	P <0.001
Major VTE	4/1686	0.2% (0.1% to 0.6%)	33/1678	2.0% (1.4% to 2.8%)	1.7% (1.0% to 2.5%)	<0.001	88% (66%-96%)	P <0.001
Death from all causes	4/1595	0.3% (0.1% to 0.6%)	4/1558	0.3% (0.1% to 0.7%)	0.0% (-0.4% to 0.4%)	1.00	--	--
Nonfatal PE	4/1595	0.3% (0.1% to 0.6%)	1/1558	0.1% (<0.1% to 0.4%)	-0.2% (-0.6% to 0.1%)	0.37	--	--
DVT (proximal and/or distal)	12/1595	0.8% (0.4% to 1.3%)	53/1558	3.4% (2.6% to 4.4%)	2.7% (1.7% to 3.7%)	<0.001	--	--
Proximal DVT	1/1595	0.1% (<0.1% to 0.4%)	31/1558	2.0% (1.4% to 2.8%)	1.9% (1.2% to 2.7%)	<0.001	--	--
Distal DVT only	11/1595	0.7% (0.3% to 1.2%)	22/1558	1.4% (0.9% to 2.1%)	0.7% (0.0% to 1.5%)	0.04	--	--
VTE-related death	0/1595	0%	1/1558	<0.1%	--	--	--	--
Symptomatic VTE^e	6/2193	0.3% (0.1% to 0.6%)	11/2206	0.5% (0.3% to 0.9%)	0.2% (-0.1% to 0.6%)	0.22	--	--

a Total VTE = composite of DVT (proximal and/or distal), nonfatal PE, or death from all causes.

b Major VTE = composite of proximal DVT, nonfatal PE, or VTE-related death

c MITT = subject valid for safety analysis, has undergone appropriate surgery, has adequate assessment of thromboembolism

d Mantel-Haenszel Weighted Reduction to Enoxaparin given for all endpoints except nonfatal PE and death from all causes, for which unweighted (exact) estimates were given. Superiority was shown if the lower limit of the CI was above zero.

e Safety population for Symptomatic VTE (patients valid for safety analysis who underwent the appropriate surgery). The safety population was used because assessment of symptomatic events is possible in the greater population, regardless of the availability of an adequate venographic assessment.

Table 18 – RECORD 3 (TKR): Superiority Analysis for Total VTE (Primary Composite Endpoint)^a, Major VTE (Main Secondary Endpoint)^b and Their Components, and Other Selected Efficacy Endpoints – Modified ITT (MITT)^c Population Through the Double-Blind Treatment Period

Parameter	XARELTO 10 mg		Enoxaparin 40 mg		Absolute Risk Reduction ^d	P-Value	Relative Risk Reduction	P-Value
	n/N	% (95% CI)	n/N	% (95% CI)	% (95% CI)		% (95% CI)	
Total VTE	79/824	9.6% (7.7% to 11.8%)	166/878	18.9% (16.4% to 21.7%)	9.2% (5.9% to 12.4%)	<0.001	49% (35%-61%)	<0.001
Major VTE	9/908	1.0% (0.5% to 1.9%)	24/925	2.6% (1.7% to 3.8%)	1.6% (0.4% to 2.8%)	0.01	62% (18%-82%)	0.016
Death from all causes	0/824	0% (0.0% to 0.5%)	2/878	0.2% (0.0% to 0.8%)	0.2% (-0.2% to 0.8%)	0.23	--	--
Nonfatal PE	0/824	0% (0.0% to 0.3%)	4/878	0.5% (0.1% to 1.2%)	0.5% (0.0% to 1.2%)	0.06	--	--
DVT (proximal and/or distal)	79/824	9.6% (7.7% to 11.8%)	160/878	18.2% (15.7% to 20.9%)	8.4% (5.2% to 11.7%)	<0.001	--	--
Proximal DVT	9/824	1.1% (0.5% to 2.1%)	20/878	2.3% (1.4% to 3.5%)	1.1% (-0.1% to 2.3%)	0.07	--	--
Distal DVT only	70/824	8.5% (6.7% to 10.6%)	140/878	15.9% (13.6% to 18.5%)	7.3% (4.3% to 10.4%)	<0.001	--	--
VTE-related death	0/824	0%	0/878	0%	--	--	--	--
Symptomatic VTE^e	8/1201	0.7% (0.3% to 1.3%)	24/1217	2.0% (1.3% to 2.9%)	1.3% (0.4% to 2.2%)	0.005	--	--

a Total VTE = composite of DVT (proximal and/or distal), nonfatal PE, or death from all causes.

b Major VTE = composite of proximal DVT, nonfatal PE, or VTE-related death

c MITT = subject valid for safety analysis, has undergone appropriate surgery, has adequate assessment of thromboembolism

d Mantel-Haenszel Weighted Reduction to Enoxaparin given for all endpoints except nonfatal PE and death from all causes, for which unweighted (exact) estimates were given. Superiority was shown if the lower limit of the CI was above zero.

e Safety population for Symptomatic VTE (patients valid for safety analysis who underwent the appropriate surgery). The safety population was used because assessment of symptomatic events is possible in the greater population, regardless of the availability of an adequate venographic assessment.

The efficacy results of the pre-specified analysis using a modified intent-to-treat population indicate that XARELTO 10 mg administered postoperatively once daily is superior in preventing DVT to enoxaparin 40 mg once daily (first dose 12 hours preoperatively). The Canadian approved dosage regimen for enoxaparin is 30 mg every 12 hours (first dose is to be administered 12 to 24 hours postoperatively). There are no definitive head-to-head studies to compare the safety and efficacy of the Canadian approved enoxaparin dosage regimen to the enoxaparin dosage regimen used in the RECORD 1 and 3 studies.

In the safety population of 3429 patients treated with XARELTO and 3463 patients treated with enoxaparin in the pivotal studies (RECORD 1 and 3), the results observed for bleeding events have been summarized in Table 19. In RECORD 1, serious drug-related treatment-emergent adverse events were reported in 26 (1.2%) for XARELTO and 23 (1.0%) for enoxaparin. In RECORD 3, serious drug-related treatment-emergent adverse events were reported in 26 (2.1%) for XARELTO and 19 (1.5%) for enoxaparin.

Table 19 – RECORD 1 and 3: Detailed Overview of Treatment-Emergent Bleeding Events (Safety Population)^a

	RECORD 1 (THR)			RECORD 3 (TKR)		
	XARELTO 10 mg od N=2209	Enoxaparin 40 mg od N=2224	P-Value	XARELTO 10 mg od N=1220	Enoxaparin 40 mg od N=1239	P-Value
Any Bleeding n (%) (95% CI)	133 (6.0%) (5.1% to 7.1%)	131 (5.9%) (5.0% to 7.0%)	0.90	60 (4.9%) (3.8%-6.3%)	60 (4.8%) (3.7%-6.2%)	1.0
Major Bleeding^b n (%) (95% CI)	6 (0.3%) (0.1%-0.6%)	2 (0.1%) (<0.1%-0.3%)	0.18	7 (0.6%) (0.2%-1.2%)	6 (0.5%) (0.2%-1.1%)	0.79
Fatal Bleeding^c	1 (<0.1%) ^b	0 (0.0%)	--	0 (0.0%)	0 (0.0%)	--
Bleeding into a critical organ n (%)	1 (<0.1%)	0 (0.0%)	--	1 (0.1%)	2 (0.2%)	--
Bleeding leading to reoperation n (%)	2 (0.1%)	1 (<0.1%)	--	5 (0.4%)	4 (0.3%)	--
Clinically overt extra-surgical site bleeding leading to a fall in hemoglobin n (%)	2 (0.1%)	1 (<0.1%)	--	1 (0.1%)	0 (0.0%)	--
Clinically overt extra-surgical site bleeding leading to transfusion of ≥2 units of blood n (%)	2 (0.1%)	1 (<0.1%)	--	1 (0.1%)	0 (0.0%)	--

Table 19 – RECORD 1 and 3: Detailed Overview of Treatment-Emergent Bleeding Events (Safety Population)^a

	RECORD 1 (THR)			RECORD 3 (TKR)		
	XARELTO 10 mg od N=2209	Enoxaparin 40 mg od N=2224	P-Value	XARELTO 10 mg od N=1220	Enoxaparin 40 mg od N=1239	P-Value
Nonmajor Bleeding^d n (%)	128 (5.8%)	129 (5.8%)	--	53 (4.3%)	54 (4.4%)	--
Clinically relevant nonmajor bleeding n (%)	65 (2.9%)	54 (2.4%)	--	33 (2.7%)	28 (2.3%)	--
Hemorrhagic wound complications^e n (%)	34 (1.5%)	38 (1.7%)	--	25 (2.0%)	24 (1.9%)	--

- a Patients may have had more than one type of event, and an event could fall into more than one category; adjudicated treatment-emergent bleeding events included those beginning after the initiation of the study drug and up to 2 days after last dose of the study drug.
- b Major bleeding events included: (1) fatal, (2) bleeding into a critical organ (eg, retroperitoneal, intracranial, intraocular, or intraspinal bleeding/hemorrhagic puncture), (3) bleeding requiring reoperation, (4) clinically overt extra-surgical site bleeding associated with ≥ 2 g/dL fall in hemoglobin or leading to infusion of ≥ 2 units of whole blood or packed cells.
- c The event occurred before the administration of the first dose of rivaroxaban.
- d Nonmajor bleeding events were bleeding events that did not fulfill the criteria of major bleeding.
- e Composite of excessive wound hematoma and reported surgical-site bleeding.

Phase III Supportive Study

RECORD 2 was a randomized, double-blind, double-dummy, prospective study conducted in 2509 randomized patients (safety population = 2457; mITT = 1733) undergoing THR. The aim of RECORD 2 was to assess extended thromboprophylaxis with XARELTO for 35±4 days. RECORD 2 was similar in study design, inclusion/exclusion criteria and endpoints to RECORD 1, except that enoxaparin 40 mg once daily (first dose given preoperatively) was given for a shorter duration (12±2 days) than XARELTO 10 mg od (35±4 days). Comparative efficacy claims to enoxaparin may not be drawn from this study, due to the differences in the treatment duration of XARELTO and enoxaparin.

Table 20 – RECORD 2 (THR): Superiority Analysis for Total VTE (Primary Composite Endpoint)^a, Major VTE (Main Secondary Endpoint)^b and Their Components, and Other Selected Efficacy Endpoints – Modified ITT^c (MITT) Population Through the Double-Blind Treatment Period

Parameter	XARELTO 10 mg od for 35±4 days		Enoxaparin 40 mg for 12±2 days		Absolute Risk Reduction	P-Value	Relative Risk Reduction	P-Value
	n/N	% (95% CI)	n/N	% (95% CI)	% (95% CI)		% (95% CI)	
Total VTE	17/864	2.0% (1.2% to 3.1%)	81/869	9.3% (7.5% to 11.5%)	7.3% (5.2% to 9.4%)	<0.0001	79% (65% to 87%)	< 0.001
Major VTE	6/961	0.6% (0.2% to 1.4%)	49/962	5.1% (3.8% to 6.7%)	4.5% (3.0% to 6.0%)	<0.0001	88% (71% to 95%)	< 0.001
Death from all causes	2/864	0.2% (<0.1% to 0.8%)	6/869	0.7% (0.3% to 1.5%)	0.5% (-0.2% to 1.3%)	0.29	--	--
Nonfatal PE	1/864	0.1% (<0.1% to 0.6%)	4/869	0.5% (0.1% to 1.2%)	0.3% (-0.2% to 1.1%)	0.37	--	--
DVT (proximal and/or distal)	14/864	1.6% (0.9% to 2.7%)	71/869	8.2% (6.4% to 10.2%)	6.5% (4.5% to 8.5%)	<0.0001	--	--
Proximal DVT	5/864	0.6% (0.2% to 1.3%)	44/869	5.1% (3.7% to 6.7%)	4.5% (2.9% to 6.0%)	<0.0001	--	--
Distal DVT only	9/864	1.0% (0.5% to 2.0%)	27/869	3.1% (2.1% to 4.5%)	2.0% (0.7% to 3.3%)	0.0025	--	--
VTE-related death	0/864	0%	1/869	0.1%	--	--	--	--
Symptomatic VTE^c	3/1212	0.2% (<0.1% to 0.7%)	15/1207	1.2% (0.7% to 2.0%)	1.0% (0.3% to 1.8%)	0.0040	--	--

a Total VTE = composite of DVT (proximal and/or distal), nonfatal PE, or death from all causes.

b Major VTE = composite of proximal DVT, nonfatal PE, or VTE-related death

c MITT = subject valid for safety analysis, has undergone appropriate surgery, has adequate assessment of thromboembolism

d Mantel-Haenszel Weighted Reduction to Enoxaparin given for all endpoints except nonfatal PE and death from all causes, for which unweighted (exact) estimates were given. Superiority was shown if the lower limit of the CI was above zero.

e Safety population for Symptomatic VTE (patients valid for safety analysis who underwent the appropriate surgery). The safety population was used because assessment of symptomatic events is possible in the greater population regardless of the availability of an adequate venographic assessment.

Table 21 – RECORD 2 (THR): Detailed Overview of Treatment-Emergent Bleeding Events (Safety Population)^a

	XARELTO 10 mg od for 35±4 days N=1228	Enoxaparin 40 mg od for 12±2 days N=1229	P-Value
Any Bleeding n (%) (95% CI)	81 (6.6%) (5.3% to 8.1%)	68 (5.5%) (4.3% to 7.0%)	0.27
Major Bleeding^b n (%) (95% CI)	1 (0.1%) (0.0–0.5)	1 (0.1%) (0.0–0.5)	1.00
Fatal bleeding	0 (0.0%)	0 (0.0%)	--
Bleeding into a critical organ n (%)	0 (0.0%)	1 (0.1%)	--
Bleeding leading to reoperation n (%)	0 (0.0%)	0 (0.0%)	--
Clinically overt extra-surgical site bleeding leading to a fall in hemoglobin n (%)	1 (0.1%)	0 (0.0%)	--
Clinically overt extra-surgical site bleeding leading to transfusion of ≥2 units of blood n (%)	1 (0.1%)	0 (0.0%)	--
Nonmajor Bleeding^c n (%)	80 (6.5%)	67 (5.5%)	--
Clinically relevant nonmajor bleeding n (%)	40 (3.3%)	33 (2.7%)	--
Hemorrhagic wound complications^d n (%)	20 (1.6%)	21 (1.7%)	--

a Patients may have had more than one type of event, and an event could fall into more than one category; adjudicated treatment-emergent bleeding events included those beginning after the initiation of the study drug and up to 2 days after last dose of the study drug.

b Major bleeding events included: (1) fatal, (2) bleeding into a critical organ (eg, retroperitoneal, intracranial, intraocular, or intraspinal bleeding/hemorrhagic puncture), (3) bleeding requiring reoperation, (4) clinically overt extra-surgical site bleeding associated with ≥2 g/dL fall in hemoglobin or leading to infusion of ≥2 units of whole blood or packed cells.

c Nonmajor bleeding events were bleeding events that did not fulfill the criteria of major bleeding.

d Composite of excessive wound hematoma and reported surgical-site bleeding.

The results from this study demonstrate that extended duration prophylaxis with 10 mg XARELTO od for 35 days provided clinically meaningful decreases in Total VTE, Major VTE, and symptomatic VTE in THR patients without an increased risk of bleeding.

Treatment of VTE and prevention of recurrent DVT and PE

The EINSTEIN clinical development program consisted of four Phase III studies. The EINSTEIN DVT and EINSTEIN PE studies evaluated the treatment of VTE and prevention of

recurrent DVT and PE. The EINSTEIN Extension study evaluated the benefit of continued treatment in subjects for whom clinical uncertainty regarding the absolute risk-benefit of extended duration existed.

Patients with VTE who were treated either with rivaroxaban or enoxaparin/VKA for 6 or 12 months in EINSTEIN DVT or EINSTEIN PE, or who were treated for 6 to 14 months with VKA and in whom there was equipoise to continue anticoagulant treatment were eligible for enrollment into EINSTEIN Extension. Subjects considered to have been adequately treated with 6 to 12 months of therapy or those who required more prolonged anticoagulation therapy were not included.

In EINSTEIN CHOICE, patients with confirmed symptomatic VTE who completed 6-12 months of anticoagulant treatment and in whom there was equipoise to continue anticoagulant treatment were eligible for the study. Patients with an indication for continued therapeutic-dosed anticoagulation were excluded.

Table 22 - Summary of the Pivotal Studies for the Treatment of VTE and Prevention of Recurrent DVT and PE

Study	Study Design	Treatment Regimen	Patient Population
EINSTEIN DVT	multicenter, randomized, open-label, event-driven non-inferiority study for efficacy	XARELTO 15 mg bid for 3 weeks followed by 20 mg od 3, 6 or 12 months ^a	Randomized 3449 (1731 XARELTO, 1718 Enox/VKA)
			Safety Population 3429 (1718 XARELTO, 1711 Enox/VKA)
EINSTEIN PE		Standard Therapy Enoxaparin bid bridging to therapeutic VKA 3, 6 or 12 months ^a	Per Protocol 3096 (1525 XARELTO, 1571 Enox/VKA)
			Randomized 4833, (2420 XARELTO, 2413 Enox/VKA)
			Safety Population 4817 (2412 XARELTO, 2405 Enox/VKA)
			Per Protocol 4462 (2224 XARELTO, 2238 Enox/VKA)
EINSTEIN Extension	multicenter, randomized, double-blind, placebo-controlled, event-driven, superiority study for efficacy in subjects with symptomatic proximal DVT or PE	XARELTO 20 mg once daily or placebo for 6 or 12 months ^a	Randomized 1197 (602 XARELTO, 594 placebo)

Table 22 - Summary of the Pivotal Studies for the Treatment of VTE and Prevention of Recurrent DVT and PE

Study	Study Design	Treatment Regimen	Patient Population
EINSTEIN CHOICE	multicenter, randomized, double-blind, double-dummy, active-comparator (ASA), event-driven, superiority study for efficacy in subjects with symptomatic DVT and/or PE	XARELTO 10 mg, or 20 mg or ASA 100 mg once daily ^b	Randomized 3396 (1121 XARELTO 20 mg, 1136 XARELTO 10 mg, 1139 ASA 100 mg)

a Treatment duration as determined by investigator

b Individual (actual) treatment duration depends on the individual randomization date: either 12 months, 9 to <12 months or 6 months

Safety population = The safety population comprised those subjects who received at least one dose of study medication.

bid = twice daily; od = once daily; VKA = vitamin K antagonist; enox = enoxaparin; ASA= acetylsalicylic acid

Duration of administration in EINSTEIN DVT was up to 12 months (ie, 3, 6 or 12 months) as determined by the investigator, prior to randomization, based on local risk assessment and guidelines. Nearly half of the subjects were treated for 6 to 9 months.

In EINSTEIN DVT, and EINSTEIN PE XARELTO was compared to the standard dual-drug regimen of enoxaparin administered for at least 5 days in combination with VKA until the PT/INR was in therapeutic range (≥ 2.0). VKA alone was then continued, dose-adjusted to maintain the PT/INR values within the therapeutic range of 2.0 to 3.0.

Table 23 – Co-morbid Diseases and Characteristics of Patients in EINSTEIN DVT, EINSTEIN PE and EINSTEIN Extension – ITT Population

	EINSTEIN DVT	EINSTEIN PE	EINSTEIN Extension	EINSTEIN CHOICE
Males (%)	57%	53%	58%	55%
Age, mean (years)	56	58	58	59
Creatinine Clearance (mL/min)				
<50	7%	8%	7%	5%
50 to <80	23%	25%	21%	25%
≥80	68%	66%	62%	70%
Risk Factors				
Patients with idiopathic DVT/PE	48%	49%	59%	41%
Recent surgery or trauma	19%	17%	4.1%	13%
Immobilization	15%	16%	14%	11%
Previous VTE	19%	19%	16%	18%
Mean TTR, Enox/VKA arm	58% ^a	63% ^b	n/a	n/a
North American subjects	64%	63%	n/a	n/a
Pre-randomization anticoagulation ^c	73%	92%	n/a	n/a
Actual Treatment Duration in XARELTO arm				
≥3 months	92%	92%	91%	n/a
≥6 months	68%	73%	62%	n/a
≥12 months	3%	4%	2%	n/a

a unadjusted Mean TTR. Adjusted Mean TTR is 60%.

b Adjusted mean TTR.

c Pre-randomization anticoagulation was limited to 24 hours in the majority of cases.

n/a=not applicable

Table 24 - Efficacy outcomes in EINSTEIN DVT, EINSTEIN PE and EINSTEIN Extension – ITT population

	EINSTEIN DVT			EINSTEIN PE			EINSTEIN Extension		
	XARELTO N=1731	Enox/VKA N=1718	HR ^a (95% CI) P-value	XARELTO N=2419	Enox/VKA N=2413	HR ^a (95% CI) P-value	XARELTO N=602	Placebo N=594	HR ^b (95% CI) P-value
Symptomatic Recurrent VTE ^b	36 (2.1%)	51 (3.0%)	0.68 (0.44-1.04) P<0.001 ^a	50 (2.1%)	44 (1.8%)	1.12 (0.754-1.68) P=0.0026 ^a	8 (1.3%)	42 (7.1%)	0.18 (0.09-0.39) P<0.001
Type of Symptomatic Recurrent VTE									
Fatal PE	1 (<0.1%)	0	-	3 (0.1%)	1	(<0.1%)	0	1 (0.2%)	-
Death where PE could not be ruled out	3 (0.2%)	6 (0.3%)	-	8 (0.3%)	6 (0.2%)	-	1 (0.2%)	0	-
Recurrent PE only	20 (1.2%)	18 (1.0%)	-	23 (1.0%)	20 (0.8%)	-	2 (0.3%)	13 (2.2%)	-
Recurrent DVT plus PE	1 (<0.1%)	0	-	0	2 (<0.1%)	-	n.a.	n.a.	-
Recurrent DVT only	14 (0.8%)	28 (1.6%)	-	18 (0.7%)	17 (0.7%)	-	5 (0.8%)	31 (5.2%)	-
Symptomatic recurrent VTE and all-cause mortality	69 (4.0%)	87 (5.1%)	0.72 (0.53-0.99) P=0.044 ^c	97 (4.0%)	82 (3.4%)	1.16 (0.86-1.55) P=0.3333 ^c	8 (1.3%)	43 (7.2%)	0.18 (0.085-0.38) (P<0.0001) ^c
Net Clinical Benefit	51 (2.9%)	73 (4.2%)	0.67 (0.47-0.95) P=0.027 ^c	83 (3.4%)	96 (4.0%)	0.85 (0.63-1.14) P=0.2752 ^c	12 (2.0%)	42 (7.1%)	0.28 (0.15-0.53) P<0.0001
All On-Treatment Vascular Events	12 (0.7%)	14 (0.8%)	0.79 (0.36-1.71) P=0.55 ^c	35 (1.5%)	37 (1.5%)	0.94 0.59-1.49 P=0.7780 ^c	3 (0.5)	44 (0.7%)	0.74 (0.17-3.3) P=0.69
All-cause Mortality	38 (2.2%)	49 (2.9%)	0.67 (0.44-1.02) (P=0.06) ^c	58 (2.4%)	50 (2.1%)	1.13 (0.77-1.65) P=0.5260	1 (0.2%)	2 (0.3%)	-

a P-value for non-inferiority (one-sided);

b Some patients had more than one event

c P-value for superiority (two-sided)

n.a.=not assessed

Table 25 - Efficacy outcomes in EINSTEIN CHOICE

	XARELTO 10 mg N=1127	XARELTO 20 mg N=1107	ASA 100 mg N=1137	Rivaroxaban 20 mg vs. ASA 100 mg HR^a (95% CI) P-value	Rivaroxaban 10 mg vs. ASA 100 mg HR^a (95% CI) P-value
Symptomatic Recurrent VTE ^b	13 (1.2%)	17 (1.5%)	50 (4.4)	0.34 (0.20-0.59) <i>P</i> = 0.0001 ^c	0.26 (0.14-0.47) <i>P</i> <0.001 ^c
Symptomatic recurrent VTE and all-cause mortality	15 (1.3%)	23 (2.1%)	55 (4.9%)	0.42 (0.26-0.68) <i>P</i> =0.0005	0.27 (0.15-0.47) <i>P</i> <0.0001
Net Clinical Benefit	17 (1.5%)	23 (2.1%)	53 (4.7%)	0.44 (0.27-0.71) <i>P</i> = 0.0009 ^c	0.32 (0.18-0.55) <i>P</i> = <0.0001 ^c

a *P*-value for non-inferiority (one-sided);

b Some patients had more than one event

c *P*-value for superiority (two-sided)

FAS =Full Analysis SET

EINSTEIN DVT

EINSTEIN DVT met its principal objective demonstrating that XARELTO was non-inferior to enoxaparin/VKA for the primary outcome of symptomatic recurrent VTE (HR of 0.68 [95% CI = 0.44-1.04], *P*<0.001) (Table 24 and Figure 3). The results of per-protocol analyses were similar to those of the intention-to-treat analysis. The pre-specified test for superiority was not statistically significant (*P* = 0.0764). The incidence rates for the principal safety outcome (major or clinically relevant non-major bleeding events), as well as the secondary safety outcome (major bleeding events), were similar for both groups (HR of 0.97 [95% CI = 0.76-1.22], *P* = 0.77 and HR of 0.65 [95% CI = 0.33-1.30], *P* = 0.21, respectively). The pre-defined secondary outcome of net clinical benefit, (the composite of the primary efficacy outcome and major bleeding events), was reported with a HR of 0.67 ([95% CI = 0.47-0.95], nominal *P* = 0.03) in favour of XARELTO. The relative efficacy and safety findings were consistent regardless of pre-treatment (none, LMWH, unfractionated heparin or fondaparinux) as well as among the 3, 6 and 12-month durations. In terms of other secondary outcomes, vascular events during study treatment occurred in 12 patients (0.7%) in the XARELTO arm and 14 patients (0.8%) in the enoxaparin/VKA group (HR of 0.79 [95% CI = 0.36-1.71], *P* = 0.55), and total mortality accounted for 38 (2.2%) vs. 49 (2.9%) patients in the XARELTO vs. enoxaparin/VKA arms, respectively, within intended treatment duration (*P* = 0.06).

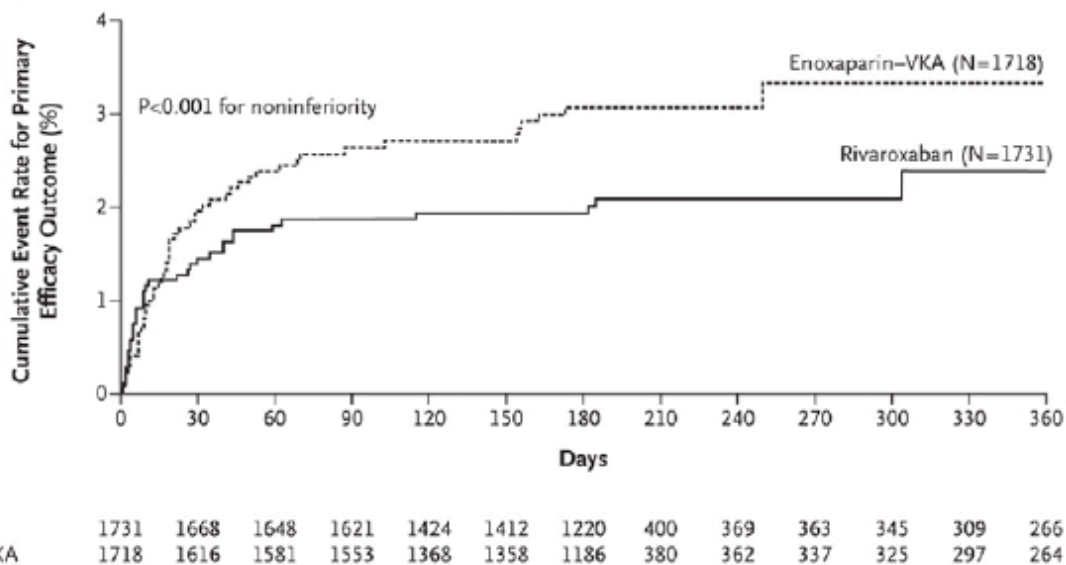

Figure 3: Kaplan-Meier Cumulative Event Rates for the Primary Efficacy Outcome in EINSTEIN-DVT – Intention-to-Treat Population

EINSTEIN PE

EINSTEIN PE met its principal objective demonstrating that XARELTO was non-inferior to enoxaparin/VKA for the primary efficacy outcome of symptomatic recurrent VTE (HR of 1.12 [95% CI: 0.75-1.68], $P=0.0026$) (Table 24 and Figure 4). The results of per-protocol analyses were similar to those of the intention-to-treat analysis. The pre-specified test for superiority was not statistically significant ($P=0.5737$). The incidence rate of the principal safety outcome (major or clinically relevant non-major bleeding events) was similar for both groups (HR of 0.90 [95% CI: 0.76 to 1.07] $P=0.2305$). For major bleeding events, the incidence rate was nominally lower in favour of XARELTO treatment group (HR of 0.49 [95% CI: 0.31 – 0.79]; $P=0.003$). The pre-defined secondary outcome of net clinical benefit (the composite of the primary efficacy outcome and major bleeding events) was reported with a HR of 0.85 ([95% CI: 0.63-1.14]; $P=0.27$) in favour of XARELTO. The relative efficacy and safety findings were consistent regardless of pre-treatment (none, LMWH, unfractionated heparin or fondaparinux) as well as among the 3, 6 and 12 month durations. In terms of other secondary outcomes, vascular events during study treatment occurred in 41 patients (1.7%) in the XARELTO arm and 39 patients (1.6%) in the enoxaparin/VKA group (HR of 1.04 [95% CI = 0.67- 1.61], $P = 0.86$), and total mortality accounted for 58 (2.4%) vs. 50 (2.1%) patients in the XARELTO vs. enoxaparin/VKA arms, respectively, within intended treatment duration ($P = 0.53$).

Graphic: Kaplan-Meier Cumulative Rate of the Primary efficacy outcome
 Timepoint: Event or censoring up to the intended treatment duration
 Population: Intent to treat

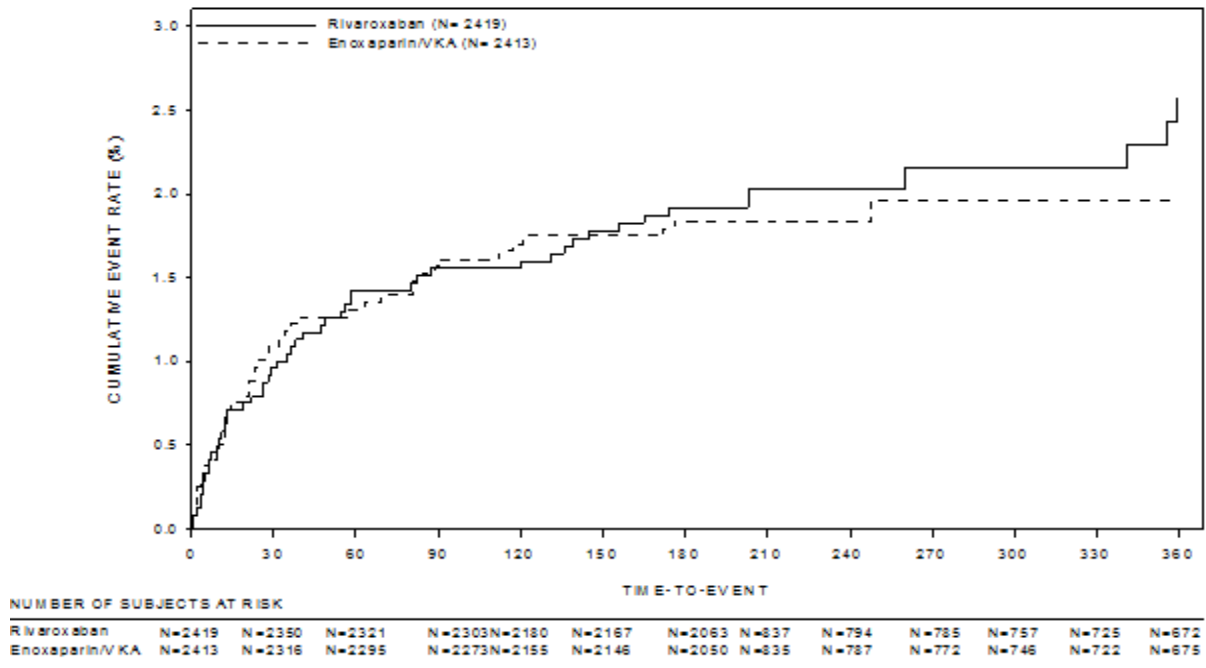

Figure 4: Kaplan-Meier analysis: cumulative rate of primary efficacy outcome in study 11702 PE - ITT Population

EINSTEIN Extension

In the EINSTEIN Extension study, XARELTO was superior to placebo for the primary efficacy outcome with a HR of 0.18 [95% CI = 0.09-0.39], $P < 0.001$ (ie, a relative risk reduction of 82%) (Table 24 and Figure 5). For the principal safety outcome (major bleeding events) there was no significant difference between patients treated with XARELTO compared to placebo ($P = 0.11$). The pre-defined secondary outcome of net clinical benefit, defined as the composite of the primary efficacy outcome and major bleeding events, was reported with a HR of 0.28 ([95% CI = 0.15-0.53], $P < 0.001$) in favour of XARELTO. In terms of other secondary outcomes, vascular events occurred in 3 patients in the XARELTO arm and 4 patients in the placebo group (HR of 0.74 [95% CI = 0.17-3.3], $P = 0.69$), and total mortality accounted for 1 (0.2%) vs. 2 (0.3%) of patients in the XARELTO vs. placebo arms, respectively.

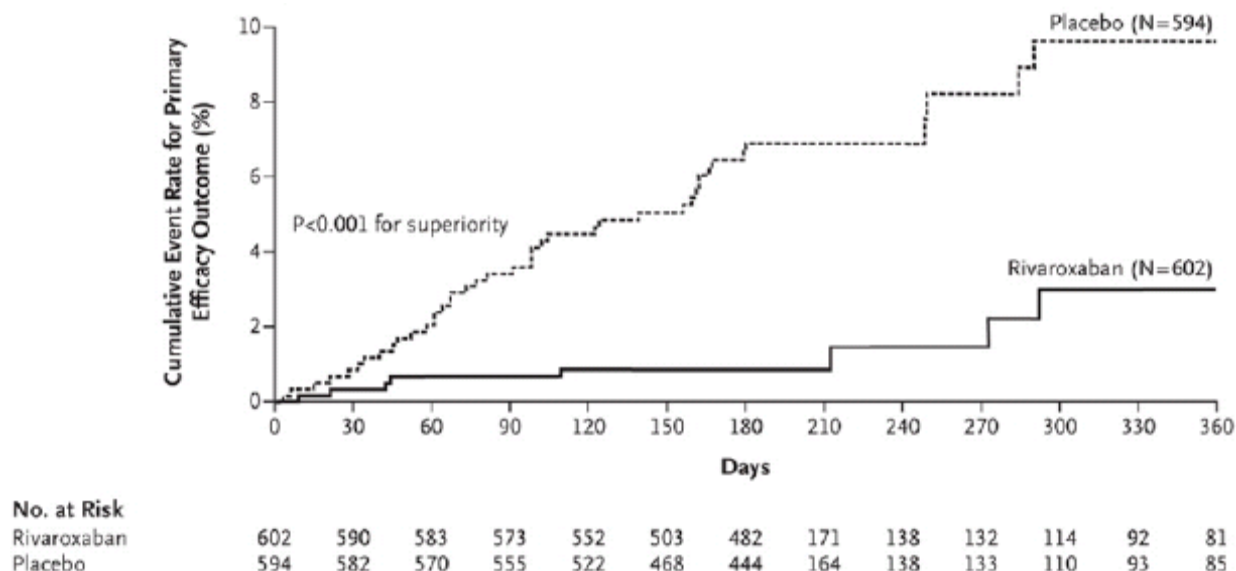

Figure 5: Kaplan-Meier Cumulative Event Rates for the Primary Efficacy Outcome in EINSTEIN Extension

EINSTEIN CHOICE

In EINSTEIN CHOICE 3,396 patients with confirmed symptomatic DVT and/or PE who completed 6-12 months of therapeutic-dose anticoagulation and who did not have an indication for continued anticoagulation in therapeutic doses, were studied for the prevention of fatal PE or non-fatal symptomatic recurrent DVT/PE. Patients with an indication for continued therapeutic-dosed anticoagulation were excluded from the study. The treatment duration was up to 12 months depending on the individual randomization date (median: 351 days). XARELTO 20 mg once daily and XARELTO 10 mg once daily were compared with 100 mg acetylsalicylic acid once daily.

The primary efficacy outcome was symptomatic recurrent VTE defined as the composite of recurrent DVT or fatal or non-fatal PE. The secondary efficacy outcome was the composite of the primary efficacy outcome, MI, ischemic stroke, or non-CNS systemic embolism.

In the EINSTEIN CHOICE study the primary efficacy objective for superiority was met for both XARELTO 20 mg and 10 mg versus acetylsalicylic acid 100mg. The secondary efficacy outcome was significantly reduced when comparing XARELTO 20 mg or 10 mg vs. 100 mg acetylsalicylic acid. The principal safety outcome (major bleeding events) was similar for patients treated with XARELTO 20 mg and 10 mg once daily compared to 100 mg acetylsalicylic acid. The secondary safety outcome (non-major bleeding associated with treatment cessation of more than 14 days) was similar when comparing XARELTO 20 mg or 10 mg vs. 100 mg acetylsalicylic acid. Outcomes were consistent across the patients with provoked and unprovoked VTE (see [Table 25](#)).

In a prespecified net clinical benefit analysis (NCB) (primary efficacy outcome plus major bleeding events) of EINSTEIN CHOICE , a HR of 0.44 (95% CI 0.27 - 0.71, p = 0.0009) for XARELTO 20 mg once daily vs 100 mg acetylsalicylic acid once daily and a HR of 0.32 (95% CI 0.18 - 0.55, p <0.0001) for XARELTO 10 mg once daily vs 100 mg acetylsalicylic acid once daily were reported.

Kaplan-Meier plot of cumulative rate of the Primary Efficacy Outcome up to the end of individual intended treatment duration (full analysis set)

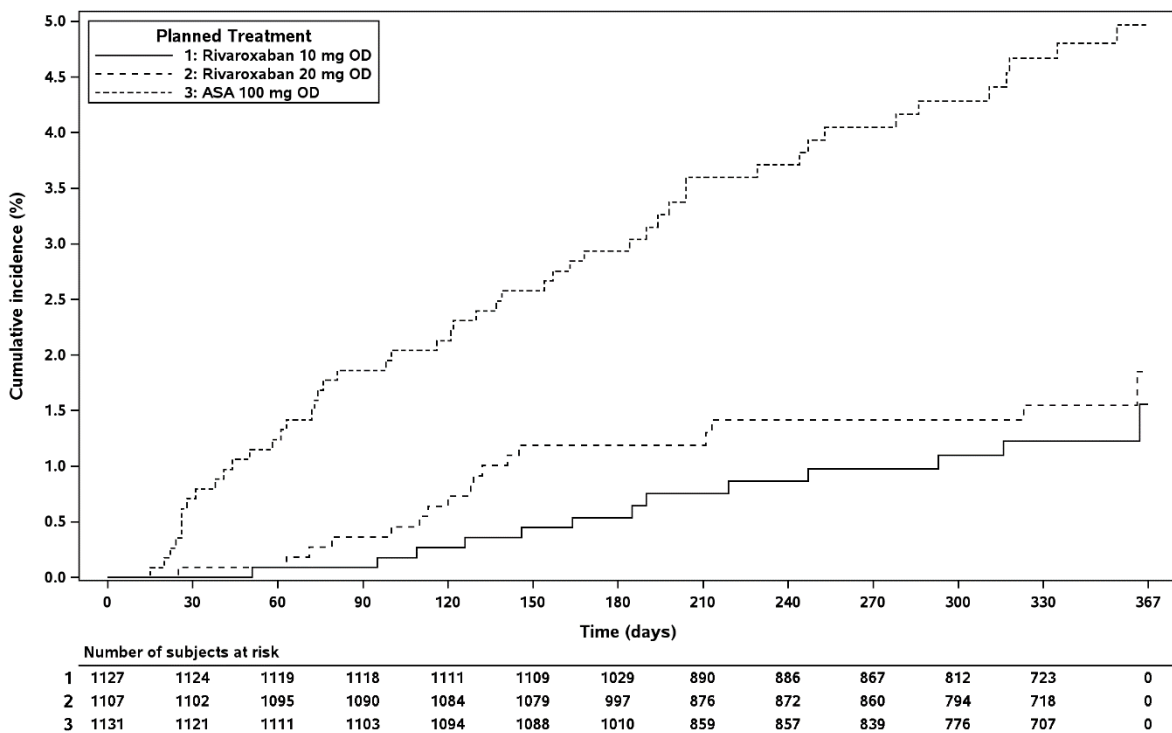

Bayer: /by-sasp/patdb/projects/597939/16416/stat/prod/pgms/tf_14_2_2_adtte_efficacy_km_cum.sas erjli 19DEC2016 13:59

Figure 6: Kaplan-Meier analysis: cumulative event rates of the primary efficacy outcome until the end of individual intended treatment duration (FAS)

Prevention of Stroke and Systemic Embolism in Patients with Atrial Fibrillation

Evidence for the effectiveness of XARELTO is derived from the ROCKET AF trial, a prospective, randomized, double-blind, double-dummy, parallel-group, multicenter, pivotal clinical study comparing the efficacy and safety of once daily oral XARELTO with dose-adjusted warfarin in patients with atrial fibrillation at risk of stroke or systemic embolism. In addition to documented atrial fibrillation, patients had prior stroke, TIA or systemic embolism, or 2 or more of the following risk factors without prior stroke:

- clinical heart failure and/or left ventricular ejection fraction $\leq 35\%$
- hypertension
- age ≥ 75 years
- diabetes mellitus

Table 26 – Summary of the ROCKET AF Trial, a Phase III Clinical Trial in Atrial Fibrillation

Study	Study Design	Treatment Regimen	Populations
ROCKET AF	double-blind, double-dummy prospective randomized parallel-group multinational study	XARELTO 20 mg od (15 mg od for patients with moderate renal impairment [CrCl 30 – 49 mL/min]) Warfarin dose adjusted to an INR of 2.5 (range 2.0 to 3.0)	Randomized 14,264 (7131 XARELTO, 7133 warfarin) Safety Population 14,236 (7111 XARELTO, 7125 warfarin) Per Protocol 14,054 (7008 XARELTO, 7046 warfarin)

Randomized = The randomized / intent-to-treat population represent all uniquely randomized patients.

Safety population = The safety population comprised those patients who received at least 1 dose of study drug.

Per Protocol = The per-protocol population was all intent to-treat patients excluding those who have specific pre-defined major protocol deviations that occur by the time of enrollment into the study or during the trial.

od = once daily

Patients with prosthetic heart valves, or those with hemodynamically significant rheumatic heart disease, especially mitral stenosis, were excluded from the ROCKET AF study, and thus were not evaluated. These trial results do not apply to patients these conditions, whether in the presence or absence of atrial fibrillation (see [WARNINGS AND PRECAUTIONS – Cardiovascular, Patients with valvular disease](#)).

The primary objective of this study was to demonstrate that XARELTO, a direct Factor-Xa inhibitor, was non-inferior to warfarin in reducing the occurrence of the composite endpoint of stroke and systemic embolism. If non-inferiority was shown, a pre-specified step-wise multiple testing procedure was undertaken to determine whether XARELTO was superior to warfarin in primary and secondary endpoints.

The study design, treatment regimen and patient populations are summarized in [Table 27](#) and [Table 28](#). A total of 14,264 patients were randomized with a mean age of 71 years (range 25 to 97 years) and a mean CHADS₂ score of 3.5. Patients were randomized to 20 mg once daily XARELTO (15 mg in patients with moderate renal impairment at screening) or to dose-adjusted warfarin, titrated to an INR of 2.0 to 3.0. ROCKET AF had a mean treatment duration of 572 days of XARELTO given as a fixed dose without routine coagulation monitoring.

ROCKET AF studied patients with significant co-morbidities, eg, 55% secondary prevention population (prior stroke / TIA / systemic embolism), see [Table 27](#). For patients randomized to warfarin, the time-in-therapeutic range (TTR) of 2.0 to 3.0 was a mean of 55% (cf. 64% in North American patients).

Table 27 – Co-morbid Diseases and Characteristics of Patients in ROCKET AF Trial – ITT Population

Heart failure and/or left ventricular ejection fraction $\leq 35\%$	62%
Hypertension	91%
Age ≥ 75 years	44%
Female	40%
Diabetes	40%
Prior Stroke / TIA / Systemic Embolism	55%
Stroke ^a	34%
TIA ^a	22%
Systemic Embolism ^a	4%
Valvular Disease (not meeting exclusion criteria) ^b	14%
Mean CHADS ₂	3.5
Prior VKA Use	62%
Prior MI	17%

a Some patients may have had more than one event, so sum of individual components do not add up to 55%.

b Patients with prosthetic heart valves, or those with hemodynamically significant rheumatic heart disease, especially mitral stenosis were excluded from ROCKET AF. Patient with other valvular disease including aortic stenosis, aortic regurgitation, and/or mitral regurgitation did not meet the exclusion criteria.

ITT Population = 14,264 patients

At baseline, 36.5% of patients were on chronic ASA, 2.4% on anticoagulants other than VKAs, 8.7% on Class III antiarrhythmics, 54.5% on angiotensin converting enzyme (ACE) inhibitors, 22.7% on angiotensin receptor blockers, 60.0% on diuretics, 24.0% on oral antidiabetics, and 65.5% on beta blockers.

ROCKET AF demonstrated that in patients with atrial fibrillation, XARELTO is non-inferior to warfarin in the primary efficacy endpoint, a composite of prevention of stroke and systemic embolism in the per protocol population, on-treatment analysis (rivaroxaban: 1.71%/year, warfarin 2.16%/year, HR 0.79, 95% CI 0.66-0.96, $P < 0.001$). As non-inferiority was met, XARELTO was tested, as per the pre-specified analysis, for superiority in primary and secondary endpoints. XARELTO demonstrated superiority over warfarin for stroke and systemic embolism in the safety population, on-treatment analysis (HR 0.79, 95% CI 0.65 to 0.95, $P = 0.015$), see [Table 28](#) and [Figure 7](#) below.

Table 28 – ROCKET AF – Time to the First Occurrence of Total Stroke and Systemic Embolism, While on Treatment (up to Last Dose Plus 2 Days) – Safety Population

Parameter	XARELTO (N=7061)		Warfarin (N=7082)		XARELTO vs Warfarin	
	n	%/year	n	%/year	Hazard Ratio (95% CI)	P-value for superiority
Total stroke and systemic embolism (Primary Efficacy Outcome)	189	1.70	243	2.15	0.79 (0.65,0.95)	0.015*
Total Stroke	184	1.65	221	1.96	0.85 (0.70,1.03)	0.092
Hemorrhagic Stroke	29	0.26	50	0.44	0.59 (0.37,0.93)	0.024*
Ischemic Stroke	149	1.34	161	1.42	0.94 (0.75,1.17)	0.581
Unknown Stroke Type	7	0.06	11	0.10	0.65 (0.25,1.67)	0.366
Systemic Embolism	5	0.04	22	0.19	0.23 (0.09,0.61)	0.003*
Other Endpoints						
All Cause Death	208	1.87	250	2.21	0.85 (0.70,1.02)	0.073
Vascular Death	170	1.53	193	1.71	0.89 (0.73,1.10)	0.289
Myocardial Infarction	101	0.91	126	1.12	0.81 (0.63,1.06)	0.121

Safety population on-treatment analysis = Events (Adjudicated by CEC) While on Treatment (up to Last Dose Plus 2 Days) – Safety Population

Hazard ratio (95% CI) and P-value from Cox proportional hazard model with treatment group as a covariate. p-value (two-sided) for superiority of XARELTO versus warfarin in hazard ratio

* Statistically significant

While the pre-specified primary analysis for superiority used the on-treatment data set for the safety population, an intention-to treat (ITT) analysis was also conducted. In this analysis, the primary endpoint occurred in 269 patients in the rivaroxaban group (2.1% per year) and in 306 patients in the warfarin group (2.4% per year) (hazard ratio, 0.88; 95% CI, 0.74 to 1.03; $P < 0.001$ for non-inferiority; $P = 0.12$ for superiority).

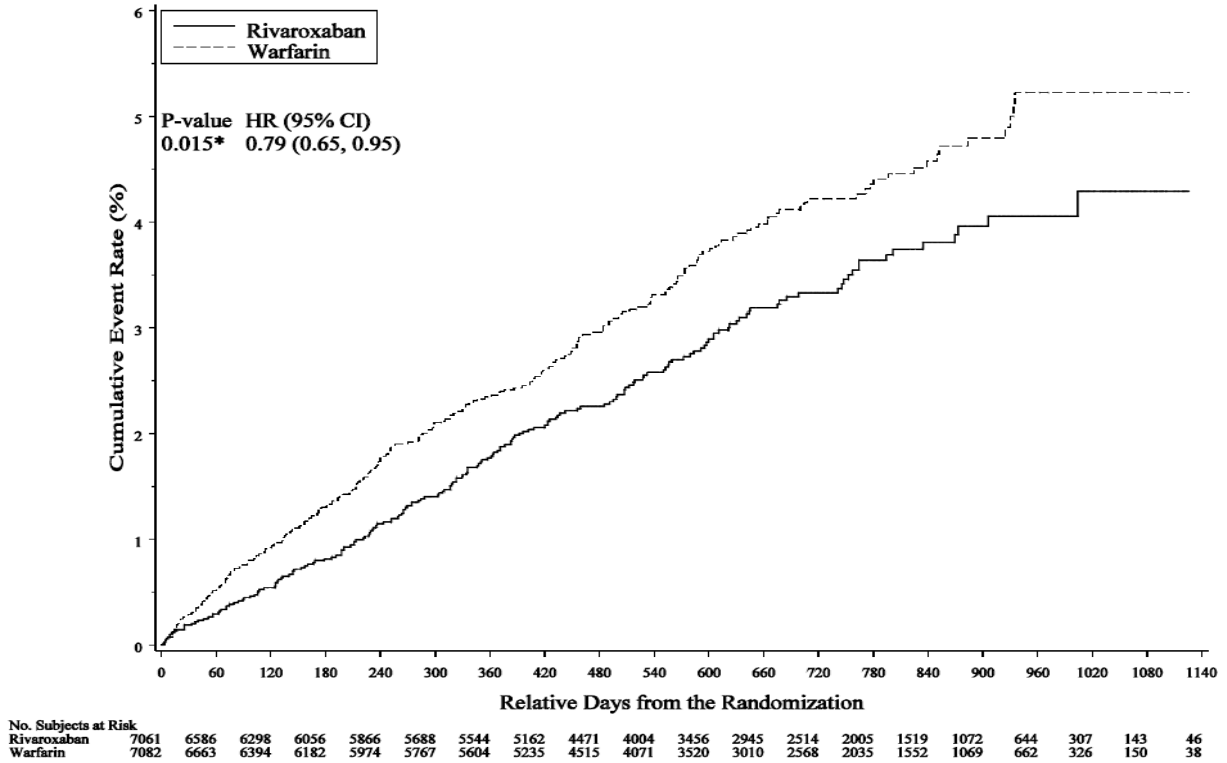

Figure 7: Kaplan-Meier curve of time to first total stroke or systemic embolism in the ROCKET AF trial safety population, on-treatment analysis, includes the 15 mg and 20 mg doses of rivaroxaban

The analysis of the principal safety endpoint demonstrates XARELTO has a similar rate to warfarin for the composite of major and non-major clinically relevant bleeding, see [Table 29](#) below.

Table 29 – ROCKET AF – Time to the First Occurrence of Bleeding Events While on Treatment (up to Last Dose Plus 2 Days) – Safety Population

Parameter	XARELTO (N=7111)		Warfarin (N=7125)		XARELTO vs Warfarin	
	n	%/year	N	%/year	Hazard Ratio (95% CI)	P-value
Major and Non-major clinically relevant bleeding event (Principal Safety Endpoint)	1475	14.91	1449	14.52	1.03 (0.96,1.11)	0.442
Major Bleeding	395	3.60	386	3.45	1.04 (0.90,1.20)	0.576
Hemoglobin Drop (2g/dL)	305	2.77	254	2.26	1.22 (1.03,1.44)	0.019*
Transfusion (> 2 units)	183	1.65	149	1.32	1.25 (1.01,1.55)	0.044*
Critical Organ Bleed	91	0.82	133	1.18	0.69 (0.53,0.91)	0.007*
Intracranial Hemorrhage	55	0.49	84	0.74	0.67 (0.47, 0.94)	0.019*
Fatal Bleed	27	0.24	55	0.48	0.50 (0.31,0.79)	0.003*
Non-major Clinically Relevant Bleeding	1185	11.80	1151	11.37	1.04 (0.96,1.13)	0.345

All analysis are based on the time to the first event.

Hemoglobin drop = a fall in hemoglobin of 2 g/dL or more.

Transfusion = a transfusion of 2 or more units of packed red blood cells or whole blood.

Critical organ bleeding are cases where CEC bleeding site=intracranial, intraspinal, intraocular, pericardial, intra-articular, intramuscular with compartment syndrome or retroperitoneal.

Hazard ratio (95% CI) and P-value from Cox proportional hazard model with treatment group as a covariate.

P-value (two-sided) for superiority of XARELTO versus Warfarin in hazard ratio.

* Statistically significant

The incidences of increased liver function tests were low and comparable between the two groups, see [Table 30](#).

Table 30 – ROCKET AF – Incidence of Pre-specified Post-baseline Liver Function Abnormalities – Safety Population

Parameter	XARELTO (N=7111)		Warfarin (N=7125)		XARELTO vs Warfarin Hazard Ratio (95% CI)
	n/J	%	n/J	%	
ALT> 3xULN	203/6979	2.91	203/7008	2.90	1.01 (0.83,1.23)
ALT > 3xULN and TBL > 2xULN	31/6980	0.44	33/7012	0.47	0.95 (0.58,1.55)

ULN = Upper Limit of Normal Range, n = Number of patients with events, N= Number of patients valid for safety population, J = Number of patients with non-missing lab values, TBL: Total Bilirubin

Hazard Ratio (95% CI): time to event analysis using a Cox model with the treatment as the covariate.

The event rates for efficacy and safety outcomes stratified by age groups are presented in [Table 31](#) and [Table 32](#). The event rates for efficacy and safety outcomes stratified by renal function are presented in [Table 33](#) and [Table 34](#).

Table 31 – Efficacy Outcomes by Age Groups in the ROCKET AF Trial, While on Treatment (up to Last Dose Plus 2 Days) – Safety Population

	XARELTO		Warfarin		XARELTO vs Warfarin	
	n/J	Event rate (%/yr)	n/J	Event rate (%/yr)	Hazard Ratio (95% CI)	P-value
Total Stroke and Systemic Embolism (Primary Efficacy Outcome)						
All Patients	189/7061	1.70	243/7082	2.15	0.79 (0.65,0.95)	0.015*
< 65 years	43/1642	1.59	42/1636	1.53	1.04 (0.68,1.58)	-
65 to 75 years	77/2767	1.74	98/2768	2.18	0.79 (0.59,1.07)	-
> 75 years	69/2652	1.73	103/2678	2.54	0.68 (0.50,0.92)	-
> 80 years	40/1305	2.17	46/1281	2.39	0.91 (0.60,1.40)	-
≥85 years	7/ 321	1.75	9/ 328	1.91	0.92 (0.34,2.47)	-
Total Stroke						
All Patients	184/7061	1.65	221/7082	1.96	0.85 (0.70,1.03)	0.092
< 65 years	42/1642	1.55	36/1636	1.31	1.18 (0.76,1.84)	-
65 to 75 years	75/2767	1.69	90/2768	2.00	0.84 (0.62,1.14)	-
> 75 years	67/2652	1.68	95/2678	2.34	0.72 (0.52,0.98)	-
> 80 years	38/1305	2.06	42/1281	2.18	0.95 (0.61,1.48)	-
Ischemic Stroke						
All Patients	149/7061	1.34	161/7082	1.42	0.94 (0.75,1.17)	0.581
< 65 years	30/1642	1.11	23/1636	0.84	1.32(0.77,2.28)	-
65 to 75 years	68/2767	1.53	66/2768	1.47	1.04 (0.74,1.46)	-
> 75 years	51/2652	1.28	72/2678	1.77	0.72 (0.50,1.03)	-
> 80 years	26/1305	1.41	33/1281	1.71	0.83 (0.50,1.39)	-
Hemorrhagic Stroke						
All Patients	29/7061	0.26	50/7082	0.44	0.59 (0.37,0.93)	0.024*
< 65 years	9/1642	0.33	12/1636	0.44	0.76 (0.32,1.80)	-
65 to 75 years	4/2767	0.09	19/2768	0.42	0.21 (0.07,0.62)	-
> 75 years	16/2652	0.40	19/2678	0.47	0.86 (0.44,1.67)	-
> 80 years	12/1305	0.65	9/1281	0.47	1.40 (0.59,3.31)	-

Table 31 – Efficacy Outcomes by Age Groups in the ROCKET AF Trial, While on Treatment (up to Last Dose Plus 2 Days) – Safety Population

	XARELTO		Warfarin		XARELTO vs Warfarin	
	n/J	Event rate (%/yr)	n/J	Event rate (%/yr)	Hazard Ratio (95% CI)	P-value
Vascular Death						
All Patients	170/7061	1.53	193/7082	1.71	0.89 (0.73,1.10)	0.289
< 65 years	35/1642	1.29	44/1636	1.60	0.81 (0.52,1.26)	-
65 to 75 years	66/2767	1.49	70/2768	1.56	0.95 (0.68,1.33)	-
> 75 years	69/2652	1.73	79/2678	1.94	0.89 (0.64,1.23)	-
> 80 years	34/1305	1.84	35/1281	1.81	1.01 (0.63,1.62)	-
≥85 years	15/ 321	3.75	12/ 328	2.54	1.44 (0.67,3.08)	-

Safety population on-treatment analysis = Events (Adjudicated by CEC) While on Treatment (up to Last Dose Plus 2 Days) – Safety Population

n=number of patients with events, J=number of patients in each subgroup.

Hazard ratio (95% CI) and p-value from Cox proportional hazard model with treatment group as a covariate.

P-value (two-sided) for superiority of XARELTO versus warfarin in hazard ratio

* Statistically significant

Table 32 – Bleeding Endpoints by Age Groups in the ROCKET AF trial, While on Treatment (up to Last Dose Plus 2 Days) – Safety Population

	XARELTO		Warfarin		XARELTO vs. Warfarin	
	n/J	Event rate (%/yr)	n/J	Event rate (%/yr)	Hazard Ratio (95% CI)	P-value
Major and Non-major Clinically Relevant Bleeding Event (Principal Safety Endpoint)						
All Patients	1475/7111	14.91	1449/7125	14.52	1.03 (0.96,1.11)	0.442
< 65 years	241/1646	9.73	260/1642	10.41	0.93 (0.78,1.11)	-
65 to 75 years	541/2777	13.59	556/2781	13.95	0.98 (0.87,1.10)	-
> 75 years	693/2688	20.18	633/2702	18.09	1.12(1.00,1.25)	-
> 80 years	362/1320	22.79	313/1298	18.84	1.20 (1.04,1.40)	-
≥85 years	89/ 326	25.46	90/ 335	22.29	1.13 (0.84,1.52)	-
Major Bleeding						
All Patients	395/7111	3.60	386/7125	3.45	1.04 (0.90,1.20)	0.576
< 65 years	59/1646	2.21	59/1642	2.16	1.02 (0.71,1.46)	-
65 to 75 years	133/2777	3.04	148/2781	3.34	0.91 (0.72,1.15)	-
> 75 years	203/2688	5.16	179/2702	4.47	1.15 (0.94,1.41)	-
> 80 years	118/1320	6.50	86/1298	4.50	1.44 (1.09,1.90)	-
≥85 years	28/ 326	7.05	32/ 335	6.91	1.01 (0.61,1.67)	-

Table 32 – Bleeding Endpoints by Age Groups in the ROCKET AF trial, While on Treatment (up to Last Dose Plus 2 Days) – Safety Population

	XARELTO		Warfarin		XARELTO vs. Warfarin	
	n/J	Event rate (%/yr)	n/J	Event rate (%/yr)	Hazard Ratio (95% CI)	P-value
Intracranial Hemorrhage						
All Patients	55/7111	0.49	84/7125	0.74	0.67 (0.47,0.93)	0.019*
< 65 years	13/1646	0.48	17/1642	0.62	0.78 (0.38,1.60)	-
65 to 75 years	13/2777	0.29	34/2781	0.75	0.39 (0.20,0.73)	-
> 75 years	29/2688	0.72	33/2702	0.81	0.89 (0.54,1.47)	-
> 80 years	22/1320	1.18	15/1298	0.77	1.54 (0.80,2.96)	-
Fatal Bleeding						
All Patients	27/7111	0.24	55/7125	0.48	0.50 (0.31,0.79)	0.003*
< 65 years	7/1646	0.26	11/1642	0.40	0.65 (0.25,1.66)	-
65 to 75 years	7/2777	0.16	19/2781	0.42	0.37 (0.16,0.89)	-
> 75 years	13/2688	0.32	25/2702	0.61	0.53 (0.27,1.03)	-
> 80 years	10/1320	0.54	12/1298	0.62	0.87 (0.38,2.02)	-
Non-major Clinically Relevant Bleeding						
All Patients	1185/7111	11.80	1151/7125	11.37	1.04 (0.96,1.13)	0.345
< 65 years	191/1646	7.62	210/1642	8.32	0.91 (0.75,1.11)	-
65 to 75 years	444/2777	11.00	445/2781	11.02	1.00 (0.88,1.14)	-
> 75 years	550/2688	15.74	496/2702	13.93	1.13 (1.00,1.28)	-
> 80 years	276/1320	17.06	249/1298	14.74	1.15 (0.97,1.37)	-

Safety population on-treatment analysis = Events (Adjudicated by CEC) While on Treatment (up to Last Dose Plus 2 Days) – Safety Population

n=number of patients with events, J=number of patients in each subgroup.

Hazard ratio (95% CI) and P-value from Cox proportional hazard model with treatment group as a covariate.

p-value (two-sided) for superiority of XARELTO versus warfarin in hazard ratio

* Statistically significant

Table 33 – Efficacy Outcomes Stratified by Renal Function at Study Entry in the ROCKET AF Trial, While on Treatment (up to Last Dose Plus 2 Days) – Safety Population

	XARELTO		Warfarin		XARELTO vs Warfarin	
	n/J†	Event rate (%/yr)	n/J†	Event rate (%/yr)	Hazard Ratio (95% CI)	P-value
Total Stroke and Systemic Embolism (Primary Efficacy Outcome)						
All Patients	189/7061	1.70	243/7082	2.15	0.79 (0.65,0.95)	0.015*
30 – 49 mL/min	50/1481	2.36	60/1452	2.80	0.84 (0.58,1.22)	-
50 – 80 mL/min	91/3290	1.74	128/3396	2.39	0.73 (0.56,0.96)	-
> 80 mL/min	47/2278	1.25	54/2221	1.43	0.87 (0.59,1.28)	-
Total Stroke						
All Patients	184/7061	1.65	221/7082	1.96	0.85 (0.70,1.03)	0.092
30 – 49 mL/min	49/1481	2.31	52/1452	2.42	0.95 (0.64,1.40)	-
50 – 80 mL/min	88/3290	1.68	120/3396	2.24	0.75 (0.57,0.99)	-
> 80 mL/min	46/2278	1.22	48/2221	1.27	0.95 (0.64,1.43)	-
Ischemic Stroke						
All Patients	149/7061	1.34	161/7082	1.42	0.94 (0.75,1.17)	0.581
30 – 49 mL/min	43/1481	2.03	39/1452	1.82	1.11(0.72,1.72)	-
50 – 80 mL/min	69/3290	1.32	89/3396	1.66	0.80 (0.58,1.09)	-
> 80 mL/min	36/2278	0.95	32/2221	0.85	1.12 (0.70,1.80)	-
Hemorrhagic Stroke						
All Patients	29/7061	0.26	50/7082	0.44	0.59 (0.37,0.93)	0.024*
30 – 49 mL/min	6/1481	0.28	11/1452	0.51	0.55 (0.20,1.48)	-
50 – 80 mL/min	15/3290	0.29	25/3396	0.47	0.62 (0.33,1.17)	-
> 80 mL/min	8/2278	0.21	14/2221	0.37	0.57 (0.24,1.35)	-
Vascular Death						
All Patients	170/7061	1.53	193/7082	1.71	0.89 (0.73,1.10)	0.289
30 – 49 mL/min	55/1481	2.59	54/1452	2.52	1.02 (0.70,1.49)	-
50 – 80 mL/min	75/3290	1.43	91/3396	1.69	0.85 (0.62,1.15)	-
> 80 mL/min	40/2278	1.06	47/2221	1.24	0.85 (0.56,1.29)	-

Safety population on-treatment analysis = Events (Adjudicated by CEC) While on Treatment (up to Last Dose Plus 2 Days) – Safety Population

n=number of patients with events, J=number of patients in each subgroup.

†= Patients with CrCl< 30mL/min or missing baseline CrCl are excluded from the rows of CrCl subgroups (30-49 mL/min, 50-80 mL/min, >80 mL/min). The patients are, however, included in the “All Patients” rows.

Hazard ratio (95% CI) and p-value from Cox proportional hazard model with treatment group as a covariate.

P-value (two-sided) for superiority of XARELTO versus warfarin in hazard ratio

* Statistically significant

Table 34 – Bleeding Endpoints Stratified by Renal Function at Study Entry in the ROCKET AF Trial, While on Treatment (up to Last Dose Plus 2 Days) – Safety Population

	XARELTO		Warfarin		XARELTO vs Warfarin	
	n/J ^a	Event rate (%/yr)	n/J ^a	Event rate (%/yr)	Hazard Ratio (95% CI)	p-value
Major and Non-Major Clinically Relevant Bleeding Event (Principal Safety Endpoint)						
All Patients	1475/7111	14.91	1449/7125	14.52	1.03 (0.96,1.11)	0.442
30 – 49 mL/min	336/1498	17.87	341/1472	18.28	0.98 (0.84,1.14)	-
50 – 80 mL/min	725/3313	15.74	719/3410	15.30	1.04 (0.93,1.15)	-
> 80 mL/min	412/2288	12.15	388/2230	11.42	1.06(0.92,1.21)	-
Major Bleeding						
All Patients	395/7111	3.60	386/7125	3.45	1.04 (0.90,1.20)	0.576
30 – 49 mL/min	99/1498	4.72	100/1472	4.72	1.00 (0.76,1.32)	-
50 – 80 mL/min	183/3313	3.54	197/3410	3.72	0.95 (0.78,1.17)	-
> 80 mL/min	112/2288	3.02	89/2230	2.38	1.26 (0.95,1.67)	-
Intracranial Hemorrhage						
All Patients	55/7111	0.49	84/7125	0.74	0.67 (0.47,0.93)	0.019*
30 – 49 mL/min	15/1498	0.70	19/1472	0.88	0.80 (0.41,1.57)	-
50 – 80 mL/min	27/3313	0.51	43/3410	0.80	0.64 (0.40,1.04)	-
> 80 mL/min	13/2288	0.34	22/2230	0.58	0.59 (0.30,1.17)	-
Fatal Bleeding						
All Patients	27/7111	0.24	55/7125	0.48	0.50 (0.31,0.79)	0.003*
30 – 49 mL/min	6/1498	0.28	16/1472	0.74	0.38 (0.15,0.97)	-
50 – 80 mL/min	14/3313	0.27	24/3410	0.45	0.60 (0.31,1.16)	-
> 80 mL/min	7/2288	0.19	15/2230	0.40	0.46 (0.19,1.14)	-
Non-major Clinically Relevant Bleeding						
All Patients	1185/7111	11.80	1151/7125	11.37	1.04 (0.96,1.13)	0.345
30 – 49 mL/min	261/1498	13.67	259/1472	13.61	1.01 (0.85,1.19)	-
50 – 80 mL/min	596/3313	12.77	570/3410	11.94	1.08 (0.96,1.21)	-
> 80 mL/min	327/2288	9.48	321/2230	9.36	1.01 (0.86,1.18)	-

Safety population on-treatment analysis = Events (Adjudicated by CEC) While on Treatment (up to Last Dose Plus 2 Days) – Safety Population

n=number of patients with events, J=number of patients in each subgroup

a= Patients with CrCl< 30 mL/min or missing baseline CrCl are excluded from the rows of CrCl subgroups (30-49 mL/min, 50-80 mL/min, >80 mL/min). The patients are, however, included in the “All Patients” rows.

Hazard ratio (95% CI) and p-value from Cox proportional hazard model with treatment group as a covariate.

P-value (two-sided) for superiority of XARELTO versus warfarin in hazard ratio

* Statistically significant

Prevention of Stroke, Myocardial Infarction, Cardiovascular Death and Prevention of Acute Limb Ischemia and Mortality in Adult Patients with CAD with or without PAD

The COMPASS study was designed to demonstrate the efficacy and safety of XARELTO 2.5 mg bid in combination with 100 mg ASA or XARELTO 5 mg bid monotherapy, for the prevention of stroke, myocardial infarction (MI) or cardiovascular (CV) death in patients with stable atherosclerotic vascular disease. In the pivotal, double-blind phase III study 27,395 unique subjects were randomly assigned to antithrombotic study drug. In 2 arms, 18,278 subjects were randomly assigned, in a 1:1 fashion, to XARELTO 2.5 mg bid in combination with ASA 100 mg od, or to ASA 100 mg od (a third study arm with 9,117 participants testing XARELTO 5 mg bid as monotherapy did not show a statistically significant difference in the reduction of stroke, MI or CV death compared to ASA 100 mg od).

Patients with established CAD, PAD or a combination of CAD and PAD were eligible. Patients with CAD who were younger than 65 years of age were also required to have documentation of atherosclerosis involving at least two vascular beds or to have at least two additional cardiovascular risk factors (current smoking, diabetes mellitus, an estimated glomerular filtration rate [eGFR] <60 ml per minute, heart failure, or non-lacunar ischemic stroke \geq 1 month earlier). Certain patients were excluded, such as those patients in need of dual antiplatelet therapy, other non-ASA antiplatelet, or oral anticoagulant therapies, as well as patients with a history of ischemic, non-lacunar stroke within 1 month, any history of hemorrhagic or lacunar stroke, or patients with eGFR < 15 ml/min.

COMPASS was stopped prematurely for superiority of the XARELTO 2.5 mg bid + ASA 100 mg od treatment combination after a mean study drug exposure of 668 days (22 months, 1.83 years).

The mean duration of follow-up was 23 months and the maximum follow-up was 3.9 years. The mean age was 68 years and 21% of the subject population were \geq 75 years. Of the patients included, 91% had CAD, 27% had PAD, and 18% had both CAD and PAD. Of the patients with CAD, 69% had prior MI, 60% had prior percutaneous transluminal coronary angioplasty (PTCA)/atherectomy/percutaneous coronary intervention (PCI), and 26% had a history of coronary artery bypass grafting (CABG) prior to study. Of the patients with PAD, 49% had intermittent claudication, 27% had peripheral artery bypass surgery or peripheral percutaneous transluminal angioplasty (PTA), 26% had asymptomatic carotid artery stenosis >50%, and 5% had limb or foot amputation for arterial vascular disease.

Study Results

Relative to ASA 100 mg od, XARELTO 2.5 mg bid in combination with ASA 100 mg od was superior in the reduction of the primary composite outcome of stroke, MI or CV death (hazard ratio [HR] 0.76; 95% CI 0.66;0.86; $p = 0.00004$). The benefit was observed early with a sustained treatment effect over the entire treatment period (see Table 35 and Figure 8). The composite secondary outcomes (composites of coronary heart disease death, or CV death, with MI, ischemic stroke, and acute limb ischemia (ALI)) as well as all-cause mortality were reduced (see Table 35). Acute limb ischemic events were reduced (HR 0.55; 95% CI 0.32-0.92). There was a numerically lower number of amputations (HR 0.64; 95% CI 0.40-1.00). Sixty-five fewer

subjects died with the combination of XARELTO 2.5 mg bid plus ASA 100 mg od vs. ASA 100 mg od alone (HR 0.82; 95% CI 0.71-0.96; p = 0.01062).

There was a significant increase of the primary safety outcome (modified International Society on Thrombosis and Haemostasis [mISTH] major bleeding events) in patients treated with XARELTO 2.5 mg twice daily in combination with ASA 100 mg once daily compared to patients who received ASA 100 mg (see Table 6). However the incidence rates for fatal bleeding events, non-fatal symptomatic bleeding into a critical organ as well as intracranial bleeding events did not differ significantly. The prespecified composite outcome for net clinical benefit (CV death, MI, stroke, fatal or symptomatic critical-organ bleeding events) was reduced (see Table 36). The results in patients with CAD with or without PAD were consistent with the overall efficacy and safety results (see Table 36).

In the 3.8% of patients with a history of ischemic, non-lacunar stroke (median time since stroke: 5 years), the reduction of stroke, MI, CV death, and the increase of major bleeding (net clinical benefit HR 0.64; 95% CI 0.4-1.0) were consistent with the overall population (see **WARNINGS AND PRECAUTIONS - Bleeding**).

Table 35 - Efficacy results from the phase III COMPASS Study

Treatment and Dosage	Overall Study Population		
	XARELTO 2.5 mg bid plus ASA 100 mg od, N=9152 n (%)	ASA 100 mg od N=9126 n (%)	Hazard Ratio (95 % CI) p-value ^b
Primary efficacy outcome: Composite of stroke, MI, CV death	379 (4.1%)	496 (5.4%)	0.76 (0.66;0.86) p = 0.00004 [#]
- Stroke*	83 (0.9%)	142 (1.6%)	0.58 (0.44;0.76) p = 0.00006
- MI	178 (1.9%)	205 (2.2%)	0.86 (0.70;1.05) p = 0.14458
- CV death	160 (1.7%)	203 (2.2%)	0.78 (0.64;0.96) p = 0.02053
Secondary efficacy outcomes: Coronary heart disease death, MI, ischemic stroke, acute limb ischemia	329 (3.6%)	450 (4.9%)	0.72 (0.63;0.83) p = 0.00001
- Coronary heart disease death**	86 (0.9%)	117 (1.3%)	0.73 (0.55;0.96) p = 0.02611
- Ischemic stroke	64 (0.7%)	125 (1.4%)	0.51 (0.38;0.69) p = 0.00001
- Acute limb ischemia***	22 (0.2%)	40 (0.4%)	0.55 (0.32;0.92) p = 0.02093

Table 35 - Efficacy results from the phase III COMPASS Study

Treatment and Dosage	Overall Study Population		
	XARELTO 2.5 mg bid plus ASA 100 mg od, N=9152 n (%)	ASA 100 mg od N=9126 n (%)	Hazard Ratio (95 % CI) p-value ^b
CV death, MI, ischemic stroke, acute limb ischemia	389 (4.3%)	516 (5.7%)	0.74 (0.65;0.85) p = 0.00001
All-cause mortality	313 (3.4%)	378 (4.1%)	0.82 (0.71;0.96) p = 0.01062
Net Clinical Benefit: CV death, MI, stroke, fatal or symptomatic critical-organ bleeding events	431 (4.7%)	534 (5.9%)	0.80 (0.70;0.91) p=0.00052

^a Intention-to-treat analysis set, primary analyses.

^b XARELTO 2.5 mg plus ASA 100 mg vs. ASA 100 mg; Log-Rank p-value.

[#] The reduction in the primary efficacy outcome was statistically superior.

* Stroke: includes ischemic stroke, hemorrhagic stroke, and uncertain or unknown stroke

**CHD: coronary heart disease death is defined as death due to acute MI, sudden cardiac death, or CV procedure.

*** Acute limb ischemia is defined as limb-threatening ischemia leading to an acute vascular intervention (i.e., pharmacologic, peripheral arterial surgery/reconstruction, peripheral angioplasty/stent, or amputation).

bid: twice daily; od: once daily; CI: confidence interval; MI: myocardial infarction; CV: cardiovascular

Table 36 - Efficacy and safety results from phase III COMPASS Study - Subgroup analysis^a

Treatment Dosage	XARELTO 2.5 mg bid in combination with ASA 100 mg od, N=9152 n (%)	ASA 100 mg od N=9126 n (%)	Hazard Ratio (95 % CI) p-value ^b
CAD patients with or without PAD*	N=8313	N=8261	
Primary efficacy outcome: Composite of stroke, MI, or CV death	347 (4.2%)	460 (5.6%)	0.74 (0.65;0.86) p = 0.00003
Primary safety outcome: Modified ISTH major bleeding	263 (3.2%)	158 (1.9%)	1.66 (1.37;2.03) p < 0.00001
Net clinical benefit**: Stroke, MI, CV death, fatal or symptomatic critical organ bleeding	392 (4.7%)	494 (6.0%)	0.78 (0.69;0.90) p = 0.00032

Table 36 - Efficacy and safety results from phase III COMPASS Study - Subgroup analysis^a

Treatment Dosage	XARELTO 2.5 mg bid in combination with ASA 100 mg od, N=9152 n (%)	ASA 100 mg od N=9126 n (%)	Hazard Ratio (95 % CI) p-value ^b
CAD patients with PAD	N=1656	N=1641	
Primary efficacy outcome: Composite of stroke, MI, or CV death	94 (5.7%)	138 (8.4%)	0.67 (0.52;0.87) p = 0.00262
Primary safety outcome: Modified ISTH major bleeding	52 (3.1%)	36 (2.2%)	1.43 (0.93;2.19) p = 0.09819
Net clinical benefit**: Stroke, MI, CV death, fatal or symptomatic critical organ bleeding	101 (6.1%)	145 (8.8%)	0.68 (0.53;0.88) p = 0.00327
CAD patients without PAD	N=6657	N=6620	
Primary efficacy outcome: Composite of stroke, MI, or CV death	253 (3.8%)	322 (4.9%)	0.77 (0.66;0.91) P = 0.00232
Primary safety outcome: Modified ISTH major bleeding	211 (3.2%)	122 (1.8%)	1.73 (1.38;2.16) P = 0.00000
Net clinical benefit**: Stroke, MI, CV death, fatal or symptomatic critical organ bleeding	291 (4.4%)	349 (5.3%)	0.82 (0.71;0.96) P = 0.01436

^a Intention-to-treat analysis set, primary analyses.

^b XARELTO 2.5 mg bid plus ASA 100 mg od vs. ASA 100 mg od; Log-Rank p-value.

* **NOTE:** The PAD and CAD subpopulations in the COMPASS trial, and hence in this analysis partly overlap each other. 65.7% of the patients in the PAD subgroup were also diagnosed with CAD; 19.8% of the patients in the CAD subgroup were also diagnosed with PAD.

** Net Clinical Benefit combines the primary composite efficacy endpoint of the COMPASS trial (stroke, MI, CV death) and only the most severe components of the primary safety endpoint: life threatening ISTH bleeding (bleeding death and symptomatic bleeding into a critical organ or site). Bleeding into a surgical site requiring reoperation, or bleeding leading to hospitalization are not part of the Clinical Benefit estimate.

modified ISTH = Modified International Society of Thrombosis and Hemostasis (ISTH) major bleeding is defined as fatal bleeding, symptomatic bleeding into critical area or organ, bleeding into surgical site requiring reoperation or bleeding leading to hospitalization.

bid: twice daily; od: once daily; CI: confidence interval; MI: myocardial infarction, CV: cardiovascular

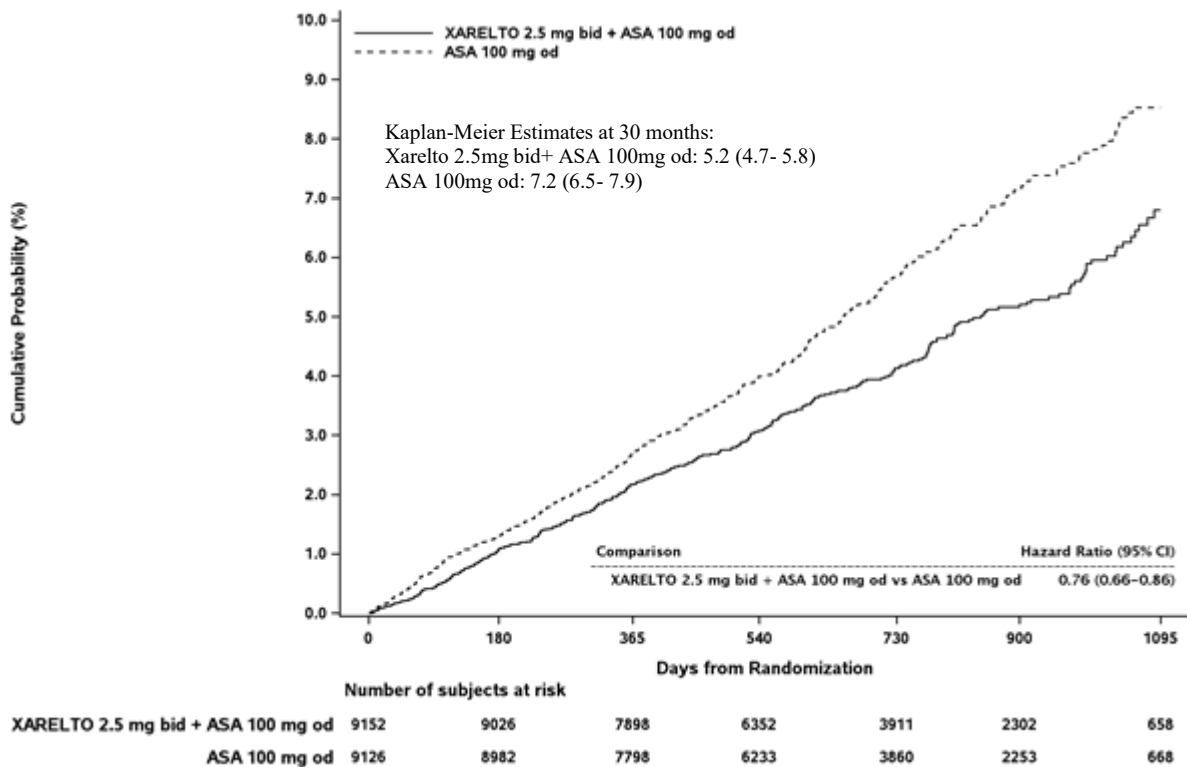

bid: twice daily; od: once daily; CI: confidence interval

Figure 8: Time to First Occurrence of Primary Efficacy Outcome (Stroke, Myocardial Infarction, Cardiovascular death) in COMPASS

Analysis of Patient Subgroups

The incidences and treatment effect of XARELTO 2.5 mg bid in combination with ASA 100 mg od for the primary efficacy and net clinical benefit outcome across major subgroups are presented in Table 37 and Table 38 below. The treatment effect was similar with no significant p-value for interaction across major subgroups.

Table 37 - Summary of the Results for the Primary Efficacy Outcome According to Patient Subgroup in the Phase III COMPASS Study

Characteristic	XARELTO 2.5 mg bid + ASA 100 mg od	ASA 100 mg od		HR (95% CI)
	No. of subjects/total no. (%)			
Overall	379/9152 (4.14%)	496/9126 (5.44%)		0.76 (0.66-0.86)
CAD with/without PAD	347/8313 (4.17%)	460/8261 (5.57%)		0.74 (0.65-0.86)
CAD with PAD	94/1656 (5.68%)	138/1641 (8.41%)		0.67 (0.52-0.87)
CAD without PAD	253/6657 (3.80%)	322/6620 (4.86%)		0.77 (0.66-0.91)
Polyvascular Disease				
1 Vascular Bed	265/7078 (3.74%)	322/7039 (4.57%)		0.81 (0.69-0.95)
2 Vascular Beds	93/1613 (5.77%)	135/1589 (8.50%)		0.67 (0.52-0.88)
3 Vascular Beds	21/456 (4.58%)	39/497 (7.85%)		0.57 (0.33-0.97)
Age				
<65	79/2150 (3.67%)	126/2184 (5.77%)		0.63 (0.48-0.84)
65-74	179/5087 (3.53%)	238/5045 (4.72%)		0.74 (0.61-0.90)
≥75	121/1924 (6.29%)	132/1897 (6.96%)		0.89 (0.69-1.14)
Sex				
Male	300/7093 (4.23%)	393/7137 (5.51%)		0.76 (0.66-0.89)
Female	79/2059 (3.84%)	103/1989 (5.18%)		0.72 (0.54-0.97)
Region				
North America	63/1304 (4.83%)	80/1309 (6.11%)		0.78 (0.56-1.08)
South America	93/2054 (4.53%)	111/2054 (5.40%)		0.84 (0.63-1.10)
Western Europe*	117/2855 (4.10%)	141/2855 (4.94%)		0.82 (0.64-1.05)
Eastern Europe	59/1607 (3.67%)	90/1604 (5.61%)		0.65 (0.46-0.90)
Asia Pacific	47/1332 (3.53%)	74/1304 (5.67%)		0.62 (0.43-0.89)
Race				
White	235/5673 (4.14%)	306/5682 (5.39%)		0.76 (0.64-0.90)
Black	2/76 (2.63%)	8/92 (8.7%)	N.C.	N.C.
Asian	54/1451 (3.72%)	81/1397 (5.80%)		0.64 (0.45-0.90)
Other	88/1952 (4.51%)	101/1955 (5.17%)		0.87 (0.65-1.16)
Weight				
≤60kg	41/901 (4.55%)	45/836 (5.38%)		0.83 (0.55-1.27)
>60kg	335/8241 (4.07%)	448/8285 (5.41%)		0.75 (0.65-0.86)
eGFR				
<60mL/min	132/2054 (6.43%)	177/2114 (8.37%)		0.75 (0.60-0.94)
≥60mL/min	247/7094 (3.48%)	319/7012 (4.55%)		0.76 (0.64-0.90)
Tobacco Use History				
Current	80/1944 (4.12%)	122/1972 (6.19%)		0.66 (0.50-0.88)
Former	186/4286 (4.34%)	224/4251 (5.27%)		0.81 (0.67-0.99)
Never	113/2922 (3.87%)	150/2903 (5.17%)		0.75 (0.59-0.95)
Diabetes				
Yes	179/3448 (5.19%)	239/3474 (6.88%)		0.74 (0.61-0.90)
No	200/5704 (3.51%)	257/5652 (4.55%)		0.77 (0.64-0.93)
Hypertension History				
Yes	317/6907 (4.59%)	409/6877 (5.95%)		0.76 (0.66-0.89)
No	62/2245 (2.76%)	87/2249 (3.87%)		0.71 (0.51-0.98)
Lipid Lowering Agent				
Yes	325/8239 (3.94%)	428/8158 (5.25%)		0.74 (0.64-0.86)
No	54/913 (5.91%)	68/968 (7.02%)		0.85 (0.60-1.22)

N.C. – Not calculated as minimum number of outcomes were not reached.

Western Europe also includes AUS/ISR/ZAF.

Table 38 - mISTH Major Bleeding Results According to Patient Subgroup in the Phase III COMPASS Study

Characteristic	XARELTO 2.5 mg bid + ASA 100 mg od	ASA 100 mg od	HR (95% CI)
	No. of subjects/total no. (%)		
Overall	288/9152 (3.15%)	170/9126 (1.86%)	1.70 (1.40-2.05)
CAD with/without PAD	263/8313 (3.16%)	158/8261 (1.91%)	1.66 (1.37-2.03)
CAD with PAD	52/1656 (3.14%)	36/1641 (2.19%)	1.43 (0.93-2.19)
CAD without PAD	211/6657 (3.17%)	122/6620 (1.84%)	1.73 (1.38-2.16)
Polyvascular Disease			
1 Vascular Bed	221/7078 (3.12%)	128/7039 (1.82%)	1.72 (1.39-2.14)
2 Vascular Beds	58/1613 (3.6%)	33/1589 (2.08%)	1.75 (1.14-2.68)
3 Vascular Beds	9/459 (1.96%)	9/497 (1.81%)	1.06 (0.42-2.66)
Age			
<65	31/2150 (1.44%)	27/2184 (1.24%)	1.18 (0.70-1.97)
65-74	156/5078 (3.07%)	96/5045 (1.90%)	1.63 (1.26-2.10)
≥75	101/1924 (5.25%)	47/1897 (2.48%)	2.12 (1.50-3.00)
Sex			
Male	224/7093 (3.16%)	142/7137 (1.99%)	1.60 (1.29-1.97)
Female	64/2059 (3.11%)	28/1989 (1.41%)	2.22 (1.42-3.46)
Region			
North America	59/1304 (4.52%)	41/1309 (3.13%)	1.45 (0.97-2.16)
South America	29/2054 (1.41%)	15/2054 (0.73%)	1.93 (1.04-3.60)
Western Europe*	119/2855 (4.17%)	69/2855 (2.42%)	1.73 (1.29-2.33)
Eastern Europe	28/1607 (1.74%)	21/1604 (1.31%)	1.32 (0.75-2.33)
Asia Pacific	53/1332 (3.98%)	24/1304 (1.84%)	2.21 (1.37-3.58)
Race			
White	194/5673 (3.42%)	127/5682 (2.24%)	1.53 (1.22-1.91)
Black	2/76 (2.63%)	3/92 (3.26%)	N.C.
Asian	57/1451 (3.93%)	25/1397 (1.79%)	2.24 (1.40-3.58)
Other	35/1952 (1.79%)	15/1955 (0.77%)	2.38 (1.30-4.36)
Weight			
≤60kg	34/901 (3.77%)	11/836 (1.32%)	2.87 (1.45-5.66)
>60kg	254/8241 (3.08%)	159/8285 (1.92%)	1.61 (1.32-1.97)
eGFR			
<60mL/min	81/2054 (3.94%)	57/2114 (2.70%)	1.47 (1.05-2.07)
≥60mL/min	206/7094 (2.90%)	113/7012 (1.61%)	1.81 (1.44-2.28)
Tobacco Use History			
Current	61/1944 (3.14%)	32/1972 (1.62%)	1.97 (1.28-3.02)
Former	145/4286 (3.38%)	95/4251 (2.23%)	1.52 (1.17-1.96)
Never	82/2922 (2.81%)	43/2903 (1.48%)	1.90 (1.32-2.75)
Diabetes			
Yes	110/3448 (3.19%)	65/3474 (1.87%)	1.70 (1.25-2.31)
No	178/5704 (3.12%)	105/5652 (1.86%)	1.69 (1.33-2.15)
Hypertension History			
Yes	222/6907 (3.21%)	138/6877 (2.01%)	1.61 (1.30-1.99)
No	66/2245 (2.94%)	32/2249 (1.42%)	2.06 (1.35-3.14)
Lipid Lowering Agent			
Yes	260/8239 (3.16%)	148/8158 (1.81%)	1.74 (1.42-2.13)
No	28/913 (3.07%)	22/968 (2.27%)	1.37 (0.78-2.40)

N.C. – Not calculated as minimum number of outcomes were not reached.
 Western Europe also includes AUS/ISR/ZAF.

DETAILED PHARMACOLOGY

Animal Pharmacology

In Vitro

XARELTO (rivaroxaban) is a competitive, selective, and direct, antithrombin independent Factor-Xa (FXa) inhibitor. It potently inhibits free human FXa, prothrombinase, and clot associated FXa. Rivaroxaban inhibits human FXa with >10 000-fold greater selectivity than for other serine proteases. Its effect on FXa resulted in a prolongation of clotting times in human plasma.

In Vivo

Rivaroxaban given prophylactically showed consistent, dose-dependent antithrombotic activity in both venous (platelet-poor, fibrin-rich) and arterial (platelet-rich, fibrin-poor) thrombosis models in mice, rats, and rabbits, with higher potency in the venous model.

In a rabbit model of venous thrombus growth, oral rivaroxaban given nonprophylactically reduced thrombus growth to a similar extent as observed with known efficacious doses of the control agents nadroparin and fondaparinux.

In a murine model of thromboembolic death, rivaroxaban provided effective protection with greater potency than enoxaparin.

PT values correlated strongly with the plasma concentrations of rivaroxaban.

The antihemostatic effect of rivaroxaban was evaluated in bleeding time models in rats and rabbits. Bleeding times were not significantly affected at antithrombotic doses below the ED50 required for antithrombotic efficacy in the arterial thrombosis models. Rivaroxaban showed an antithrombotic activity/bleeding risk ratio comparable to enoxaparin.

Safety Pharmacology

Safety pharmacology investigation on vital organ systems (cardiovascular system, respiratory system, and central nervous system) as well as on supplemental organ systems (hematology and blood coagulation, gastrointestinal function, renal function, and metabolism) revealed no adverse effect of rivaroxaban.

Studies on ventricular repolarization (hERG K⁺ current and action potential of isolated rabbit Purkinje fibers in vitro, ECG recordings in dogs) showed no evidence for a proarrhythmic risk in humans.

Human Pharmacology

Pharmacokinetics

Rivaroxaban pharmacokinetics are linear with no relevant accumulation beyond steady state after multiple doses. Variability in pharmacokinetics is moderate with interindividual variability (coefficient of variation) ranging from 30% to 40%.

Absorption and Bioavailability

Rivaroxaban is a low solubility, high permeability compound. Rivaroxaban is readily absorbed after oral administration as solution (C_{\max} after approximately 30 min) as well as tablet (C_{\max} after 2 to 4 hours). Oral bioavailability of rivaroxaban is high (80-100%) due to almost complete absorption with/without food (at doses up to 15 mg) and lack of relevant presystemic first-pass extraction of this low-clearance drug.

Due to reduced extent of absorption, an oral bioavailability of 66% was determined for the 20 mg tablet under fasting conditions. When rivaroxaban 20 mg tablets are taken together with food, increases in mean AUC by 39% and mean C_{\max} by 76% were observed when compared to tablet intake under fasting conditions, indicating almost complete absorption and high oral bioavailability when this dose was taken with food (see **DOSAGE AND ADMINISTRATION – Recommended Dose and Dosage Adjustment**).

Distribution

Plasma protein binding for rivaroxaban in humans is high at approximately 92% to 95% in vitro, with serum albumin being the main binding component. No concentration dependency and no gender difference in fraction unbound were detected. Mean rivaroxaban protein-bound fractions determined *ex vivo* in healthy subjects ranged from 90% to 95%.

Due to its high plasma protein binding, rivaroxaban is not expected to be removed by dialysis.

The binding of rivaroxaban to plasma proteins is fully reversible. In accordance with other species, rivaroxaban is mainly located in plasma; the human plasma-to-blood partition coefficient is 1.40.

Metabolism

Rivaroxaban is eliminated by metabolic degradation (approximately 2/3 of administered dose) as well as by direct renal excretion of unchanged active compound (approximately 1/3 of administered dose). In all investigated species, the oxidative degradation of the morpholinone moiety (catalyzed via CYP 3A4/CYP 3A5 and CYP 2J2 and leading via cleavage of the ring and further oxidation to metabolite M-1) was the major site of biotransformation of rivaroxaban. Unchanged rivaroxaban is the most important compound in human plasma with no major or active circulating metabolites being present. No metabolic conversion of rivaroxaban to its enantiomer was observed in humans.

Taking excretion data and metabolite profiles derived from the mass balance study in man into consideration, present data from the CYP reaction phenotyping study suggests that contribution of CYP 3A4/CYP 3A5 accounts for approximately 18% and CYP 2J2 for approximately 14% of total rivaroxaban elimination, respectively. Besides this oxidative biotransformation, hydrolysis of the amide bonds (approximately 14%) and active, transporter-mediated renal excretion of unchanged drug (approximately 30%) play important roles as elimination pathways.

Excretion

Rivaroxaban and its metabolites have a dual route of elimination, via both renal (66% in total) and biliary/fecal routes; 36% of the administered dose is excreted unchanged via the kidneys via glomerular filtration and active secretion.

The clearance and excretion of rivaroxaban is as follows:

- 1/3 of the active drug is cleared as unchanged drug by the kidneys
- 1/3 of the active drug is metabolized to inactive metabolites and then excreted by the kidneys
- 1/3 of the active drug is metabolized to inactive metabolites and then excreted by the fecal route.

Rivaroxaban has been identified *in vitro* to be a substrate both of the active transporter P-glycoprotein (P-gp) and of the multidrug transport protein BCRP ('breast cancer resistance protein').

With an average systemic plasma clearance of approximately 10 L/h, rivaroxaban is a low-clearance drug lacking relevant first-pass extraction. Mean terminal elimination half-lives of rivaroxaban are in the range of 5 h to 9 h after steady-state tablet dosing regimens in young subjects. Mean terminal elimination half-lives between 11 h to 13 h were observed in the elderly.

Special Populations and Conditions

Geriatrics (>65 Years of Age)

Results from a set of Phase I studies indicate for the target population of elderly higher mean AUC values by 52% in males and by 39% in females when compared to young subjects of the same gender, accompanied by an increase in C_{max} by 35% in both genders and by terminal half-lives between 11 and 13 h. Investigating subjects older than 75 years confirmed the expectation, leading to approximately 41% higher AUC values in comparison to young subjects (90% CI [1.20 – 1.66]), mainly due to reduced (apparent) total body clearance and renal clearance. No relevant age effects could be observed for C_{max} (C_{max} ratio 1.08; 90% CI [0.94-1.25]) or t_{max} .

Pediatrics (<18 Years of Age)

No clinical data are available for children.

Gender

There were no relevant differences in pharmacokinetics and pharmacodynamics between male and female subjects, especially when taking into account body weight differences.

Body Weight

Extremes in body weight (<50 kg or >120 kg) had only a small influence (increase in maximum concentration by <25% on rivaroxaban plasma concentrations and pharmacodynamics).

Race

Differences in rivaroxaban exposure observed between the various investigated ethnic groups — Caucasians, African-Americans, Hispanics, Chinese and Japanese — were within the normal magnitude of interindividual variability.

With respect to Factor-Xa activity and coagulation parameters, eg, prothrombin time (PT Neoplastin[®] reagent), neither age, gender, nor body weight affected the PD parameter/rivaroxaban concentration relationship, ie, all observed changes in pharmacodynamics were driven by the respective underlying plasma exposure in these specific subject populations. This is also true for the various investigated ethnic groups — Caucasians, African-Americans, Hispanics, Chinese and Japanese.

Renal Insufficiency

The safety and pharmacokinetics of single-dose XARELTO (10 mg) were evaluated in a study in healthy subjects [CrCl \geq 80 mL/min (n=8)] and in subjects with varying degrees of renal impairment (see Table 39). Compared to healthy subjects with normal creatinine clearance, rivaroxaban exposure increased in subjects with renal impairment. Increases in pharmacodynamic effects were also observed.

Table 39 - Percent Increase of Rivaroxaban PK and PD Parameters from Normal in Subjects with Renal Insufficiency from a Dedicated Renal Impairment Study

Parameter		CrCl (mL/min)		
		50 to 79	30 to 49	15 to 29
		N=8	N=8	N=8
Exposure (% increase relative to normal)	AUC	44	52	64
	C _{max}	28	12	26
FXa Inhibition (% increase relative to normal)	AUC	50	86	100
	E _{max}	9	10	12
PT Prolongation (% increase relative to normal)	AUC	33	116	144
	E _{max}	4	17	20

PT = Prothrombin time; FXa = Coagulation factor Xa; AUC = Area under the concentration or effect curve; C_{max} = maximum concentration; E_{max} = maximum effect; and CrCl = creatinine clearance

In subjects with mild renal impairment, the combined P-gp and moderate CYP 3A4 inhibitor erythromycin (500 mg three times a day) led to a 1.8-fold increase in mean rivaroxaban AUC and 1.6-fold increase in C_{max} when compared to subjects with normal renal function without co-medication. In subjects with moderate renal impairment, erythromycin led to a 2.0-fold increase in mean rivaroxaban AUC and 1.6-fold increase in C_{max} when compared to subjects with normal renal function without co-medication (see **WARNINGS AND PRECAUTIONS – Drug Interactions**). Subjects with either mild or moderate renal impairment had a 1.2- and 1.4-fold increase in Factor Xa inhibition, respectively, and a prolongation of prothrombin time of 1.7- and 1.75-fold in subjects with mild and moderate renal impairment, respectively.

Hepatic Insufficiency

The safety and pharmacokinetics of single-dose XARELTO (10 mg) were evaluated in a study in healthy subjects (n=16) and subjects with varying degrees of hepatic impairment (see Table 40). No patients with severe hepatic impairment (Child-Pugh C) were studied. Compared to healthy subjects with normal liver function, significant increases in rivaroxaban exposure were observed in subjects with moderate hepatic impairment (Child-Pugh B). Increases in pharmacodynamic effects were also observed.

Table 40 - Percent Increase of Rivaroxaban PK and PD Parameters from Normal in Subjects with Hepatic Insufficiency from a Dedicated Hepatic Impairment Study

Parameter		Hepatic Impairment Class (Child-Pugh Class)	
		Mild (Child-Pugh A)	Moderate (Child-Pugh B)
		N=8	N=8
Exposure (% increase relative to normal)	AUC	15	127
	C _{max}	0	27
FXa Inhibition (% increase relative to normal)	AUC	8	159
	E _{max}	0	24
PT Prolongation (% increase relative to normal)	AUC	6	114
	E _{max}	2	41

PT = Prothrombin time; FXa = Coagulation factor Xa; AUC = Area under the concentration or effect curve; C_{max} = maximum concentration; E_{max} = maximum effect; and CrCl = creatinine clearance

PHASE IV STUDIES

Two Phase IV clinical studies (XALIA and XANTUS) were done to evaluate the effects of rivaroxaban use under real-world (clinical practice) conditions.

XALIA

In addition to the Phase III EINSTEIN program, a prospective, non-interventional, open-label cohort study (XALIA) investigated the long-term safety of XARELTO under real-world conditions (central outcome adjudication including recurrent VTE, major bleeding and death). In 2619 XARELTO-treated patients, rates of major bleeding, recurrent VTE and all-cause mortality for XARELTO were 0.7%, 1.4% and 0.5%, respectively.

These results are consistent with the established safety profile of XARELTO in this population.

XANTUS

In addition to the Phase III ROCKET AF study, a prospective, single-arm, post-authorization, non-interventional, open-label cohort study (XANTUS) with central outcome adjudication including thromboembolic events and major bleeding has been conducted. 6,785 patients with non-valvular atrial fibrillation were enrolled for prevention of stroke and non-central nervous system (CNS) systemic embolism under real-world conditions. The mean CHADS2 score of the population was 2.0. Major bleeding incidence was 2.1 per 100 patient years. Fatal hemorrhage incidence was 0.2 per 100 patient years and intracranial hemorrhage incidence was 0.4 per 100 patient years. Stroke or non-CNS systemic embolism incidence was 0.8 per 100 patient years. These results are consistent with the established safety profile of XARELTO in this population.

TOXICOLOGY

Acute Toxicity

XARELTO (rivaroxaban) showed low acute toxicity in rats and mice.

Repeated Dose Toxicity

Rivaroxaban was tested in repeat-dose studies up to 6 months in rats and up to 12 months in dogs. Based on the pharmacological mode of action, a NOEL could not be established due to effects on clotting time. All adverse findings, except for a slight body weight gain reduction in

rats and dogs, could be related to an exaggerated pharmacological mode of action of the compound. In dogs, at very high exposures, severe spontaneous bleedings were observed. The NOAELs after chronic exposure are 12.5 mg/kg in rats and 5 mg/kg in dogs.

Carcinogenicity

In 2-year carcinogenicity studies, rivaroxaban was tested in mice, up to 60 mg/kg/day (reaching systemic exposure similar to humans) and in rats (up to 3.6-fold higher than in humans) without demonstration of carcinogenic potential.

Reproductive Toxicology

Rivaroxaban was tested in developmental toxicity studies at exposure levels of up to 38-fold (rat) and up to 89-fold (rabbit) above the therapeutic exposure in humans. The toxicological profile is mainly characterized by maternal toxicity due to exaggerated pharmacodynamic effects.

Up to the highest dose tested, no primary teratogenic potential was identified.

[¹⁴C]Rivaroxaban -related radioactivity penetrated the placental barrier in rats. In none of the fetal organs and tissues did the exposure in terms of maximum concentrations or AUC exceed the maternal blood exposure. The average exposure in the fetuses based on AUC₍₀₋₂₄₎ reached about 20% of the exposure in maternal blood. The AUC in the mammary glands was approximately equivalent to the AUC in the blood, which indicates secretion of radioactivity into milk (see **CONTRAINDICATIONS**).

Rivaroxaban did not show an effect on male or female fertility up to 200 mg/kg.

Lactation

[¹⁴C]Rivaroxaban was administered orally to lactating Wistar rats (day 8 to 10 post partum) as a single oral dose of 3 mg/kg body weight.

[¹⁴C]Rivaroxaban -related radioactivity was secreted into the milk of lactating rats only to a low extent in relation to the administered dose: The estimated amount of radioactivity excreted with milk was 2.12% of the maternal dose within 32 hours after administration (see **CONTRAINDICATIONS**).

Mutagenesis

No genotoxicity was observed in a test for gene mutation in bacteria (Ames-Test), in an in vitro test for chromosomal aberrations, or in the in vivo micronucleus test.

REFERENCES

1. Agnelli G, Gallus A, Goldhaber SZ, Haas S, Huisman MV, Hull RD, et al. Treatment of proximal deep-vein thrombosis with the oral direct factor Xa inhibitor rivaroxaban (BAY 59-7939): the ODIXa-DVT (Oral Direct Factor Xa Inhibitor BAY 59-7939 in Patients With Acute Symptomatic Deep-Vein Thrombosis) study. *Circulation*. 2007;116(2):180-7.
2. Biemond B, Perzborn E, Friederich P, Levi M, Buetehorn U, Bueller H. Prevention and treatment of experimental thrombosis in rabbits with rivaroxaban (BAY 597939) an oral, direct factor Xa inhibitor. *Thromb Haemost*. 2007;79:471-7.
3. Buller HR, editor. Oral rivaroxaban for the treatment of symptomatic venous thromboembolism: a pooled analysis for the EINSTEIN DVT and EINSTEIN PE Studies. American Society of Hematology Annual Meeting Abstracts; 2012 December 8; Georgia World Congress Center.
4. Buller HR, Prins MH, Lensing AW, Decousus H, Jacobson BF, Minar E ea. Supplementary Appendix to the article Oral Rivaroxaban for the treatment of symptomatic pulmonary embolism. *N Engl J Med*. 2012;366(14):128-97.
5. Buller HR, Prins MH, Lensin AW, Decousus H, Jacobson BF, Minar E, et al. Oral rivaroxaban for the treatment of symptomatic pulmonary embolism. *N Engl J Med*. 2012;366(14):1287-97.
6. Eriksson BI, Borris L, Dahl OE, Haas S, Huisman MV, Kakkar AK, et al. Oral, direct Factor Xa inhibition with BAY 59-7939 for the prevention of venous thromboembolism after total hip replacement. *J Thromb Haemost*. 2006;4(1):121-8.
7. Eriksson BI, Borris LC, Dahl OE, Haas S, Huisman MV, Kakkar AK, et al. A once-daily, oral, direct Factor Xa inhibitor, rivaroxaban (BAY 59-7939), for thromboprophylaxis after total hip replacement. *Circulation*. 2006;114(22):2374-81.
8. Fisher WD, Eriksson BI, Bauer KA, Borris L, Dahl OE, Gent M, et al. Rivaroxaban for thromboprophylaxis after orthopaedic surgery: pooled analysis of two studies. *Thromb Haemost*. 2007;97(6):931-7.
9. Geerts W, Bergqvist D, Pineo G, Heit J, Samama C, Lassen M, et al. Prevention of venous thromboembolism. American College of Chest Physicians evidence-based clinical practice guidelines (8th edition). *CHEST*. 2008;133:381S-453S.
10. Gibson CM, Mega JL, Burton P, Goto S, Verheugt F, Bode C, et al. Rationale and design of the Anti-Xa therapy to lower cardiovascular events in addition to standard therapy in subjects with acute coronary syndrome-thrombolysis in myocardial infarction 51 (ATLAS-ACS 2 TIMI 51) trial: a randomized, double-blind, placebo-controlled study to evaluate the efficacy and safety of rivaroxaban in subjects with acute coronary syndrome. *Am Heart J*. 2011;161(5):815-21 e6.
11. Gibson CM, Mehran R, Bode C, Halperin J, Verheugt FW, et al. Prevention of Bleeding in Patients with Atrial Fibrillation Undergoing PCI. *N Engl J Med*. 2016;375(25):2423-2434.
12. Kakkar AK, Brenner B, Dahl OE, Eriksson BI, Mouret P, Muntz J, et al. Extended duration rivaroxaban versus short-term enoxaparin for the prevention of venous

- thromboembolism after total hip arthroplasty: a double-blind, randomised controlled trial. *Lancet*. 2008;372:31-9.
13. Kubitz D, Becka M, Wensing G, Voith B, Zuehlsdorf M. Safety, pharmacodynamics, and pharmacokinetics of BAY 59-7939--an oral, direct Factor Xa inhibitor--after multiple dosing in healthy male subjects. *Eur J Clin Pharmacol*. 2005;61(12):873-80.
 14. Kubitz D, Becka M, Zuehlsdorf M, Mueck W. Body weight has limited influence on the safety, tolerability, pharmacokinetics, or pharmacodynamics of rivaroxaban (BAY 59-7939) in healthy subjects. *J Clin Pharmacol*. 2007;47(2):218-26.
 15. Lassen MR, Ageno W, Borris LC, Lieberman JR, Rosencher N, Bandel TJ, et al. Rivaroxaban versus enoxaparin for thromboprophylaxis after total knee arthroplasty. *N Engl J Med*. 2008;358(26):2776-86.
 16. Mega JL, Braunwald E, Wiviott SD, Bassand JP, Bhatt DL, Bode C, et al. Rivaroxaban in patients with a recent acute coronary syndrome. *N Engl J Med*. 2011;366(1):9-19. Supplementary Appendix. 2011:1-9
 17. Mega JL, Braunwald E, Wiviott SD, Bassand JP, Bhatt DL, Bode C, et al. Rivaroxaban in patients with a recent acute coronary syndrome. *N Engl J Med*. 2012;366(1):9-19.
 18. Moore KT, Vaidyanathan S, Natarajan J, Ariyawansa J, Haskell L, Turner KC. An open-label study to estimate the effect of steady-state erythromycin on the pharmacokinetics, pharmacodynamics, and safety of a single dose of rivaroxaban in subjects with renal impairment and normal renal function. *J Clin Pharmacol*. 2014;54(12):1407-20.
 19. Patel MR, Mahaffey KW, Garg J, Pan G, Singer DE, Hacke W, et al. Rivaroxaban versus Warfarin in Nonvalvular Atrial Fibrillation and Supplementary Appendix p. 1-23. *N Engl J Med*. 2011;365(10):883-91.
 20. Perzborn E, Strassburger J, Wilmen A, Pohlmann J, Roehrig S, Schlemmer KH, et al. In vitro and in vivo studies of the novel antithrombotic agent BAY 59-7939--an oral, direct Factor Xa inhibitor. *J Thromb Haemost*. 2005;3(3):514-21.
 21. Turpie AG, Fisher WD, Bauer KA, Kwong LM, Irwin MW, Kalebo P, et al. BAY 59-7939: an oral, direct factor Xa inhibitor for the prevention of venous thromboembolism in patients after total knee replacement. A phase II dose-ranging study. *J Thromb Haemost*. 2005;3(11):2479-86.
 22. Weitz JI, Bauersachs R, Beyer-Westendorf J, Bounameaux H, Brighton TA, Cohen AT, et al. Two doses of rivaroxaban versus aspirin for prevention of recurrent venous thromboembolism. Rationale for and design of the EINSTEIN CHOICE study. *Thromb Haemost*. 2015 Aug 31;114(3):645-50.
 23. Kenneth T. Moore, Mark A. Krook, Seema Vaidyanathan1, Troy C. Sarich, C. V. Damaraju, and Larry E. Fields. Rivaroxaban Crushed Tablet Suspension Characteristics and Relative Bioavailability in Healthy Adults When Administered Orally or Via Nasogastric Tube. *Clinical Pharmacology in Drug Development*. 2014;3(4) 321–327.
 24. Ageno W, Mantovani LG, Haas S, Kreutz R, Monje D, Schneider J, van Eickels M, Gebel M, Zell E, Turpie AG. Safety and effectiveness of oral rivaroxaban versus standard

- anticoagulation for the treatment of symptomatic deep-vein thrombosis (XALIA): an international, prospective, non-interventional study. *Lancet Haematol* 2016; 3: e12–21.
25. Camm AJ, Amarenco P, Haas S, Hess S, Kirchhof P, Kuhls S, van Eickels M, Turpie AG; XANTUS Investigators. XANTUS: a real-world, prospective, observational study of patients treated with rivaroxaban for stroke prevention in atrial fibrillation. *Eur Heart J*. 2016; Apr 7;37(14):1145-53.
 26. Connolly SJ, Eikelboom JW, Bosch J, Dagenais G, Dyal L, Lanus F, et al. Rivaroxaban with or without aspirin in patients with stable coronary artery disease: an international, randomised, double-blind, placebo-controlled trial. *Lancet*. 2017 Nov 10.
 27. Anand SS, Bosch J, Eikelboom JW, Connolly SJ, Diaz R, Widimsky P, et al. Rivaroxaban with or without aspirin in patients with stable peripheral or carotid artery disease: an international, randomised, double-blind, placebo-controlled trial. *Lancet*. 2017 Nov 10.

PART III: CONSUMER INFORMATION

PrXARELTO®
rivaroxaban tablets

This leaflet is Part 3 of a three-part "Product Monograph" published when XARELTO was approved for sale in Canada and is designed specifically for Consumers. This leaflet is a summary and will not tell you everything about XARELTO. Contact your doctor or pharmacist if you have any questions about the drug.

ABOUT THIS MEDICATION

What the medication is used for:

XARELTO 10, 15 and 20 mg tablets:

XARELTO 10 mg, 15 mg and 20 mg are used for:

- **Prevention of blood clots after major hip or knee surgery**
- **Prevention of blood clots in your brain (stroke) and in other blood vessels in your body if you have atrial fibrillation**

Blood clots could dislodge and travel to the lungs causing serious health risks. Your doctor has prescribed this medication for you because after such an operation you are at an increased risk of getting blood clots.

Your doctor has prescribed this medication for you because you have a form of irregular heart rhythm called atrial fibrillation which can lead to blood clots forming and increases your risk of a stroke.

- **Treatment and prevention of blood clots in the veins of your legs or lungs**
- Your doctor has prescribed this medication for you because you have blood clots in the veins of your legs. This makes you at risk of a blood clot dislodging and traveling to the lungs causing serious health risks.

XARELTO 2.5 mg tablets:

XARELTO 2.5 mg is used for:

- **The prevention of stroke, heart attack and severe leg pain or death**
- Your doctor has prescribed this medication for you in combination with acetylsalicylic acid (ASA, ASPIRIN®) if you have:
- A blockage in the blood vessels to the heart, called coronary artery disease, causing a lack of oxygen in

your heart. This may occur with or without the narrowing of limb arteries that causes pain, a circulatory problem called peripheral artery disease.

What it does:

XARELTO is an anticoagulant. It helps prevent blood clots from forming by directly blocking the activity of clotting Factor-Xa.

When it should not be used:

- if you have severe liver disease which leads to an increased risk of bleeding
- if you have active bleeding, especially if you are bleeding excessively
- if you are aware of body wounds or injuries at risk of bleeding, including bleeding in the brain or bleeding in your stomach or gut
- if you are taking certain oral medications to treat fungal infections or HIV/AIDS, such as NIZORAL® (ketoconazole) or NORVIR® (ritonavir)
- if you are taking other anticoagulants (blood thinners) such as warfarin, apixaban, dabigatran, edoxaban, heparin or low molecular weight heparin (LMWH) including enoxaparin, dalteparin or heparin derivatives, such as fondaparinux
- if you are pregnant or breastfeeding
- if you are allergic (hypersensitive) to rivaroxaban (active ingredient of XARELTO) or any of the other ingredients of XARELTO. The ingredients are listed in the "What the nonmedicinal ingredients are" section of this leaflet

What the medicinal ingredient is:

rivaroxaban

What the nonmedicinal ingredients are:

cellulose microcrystalline, croscarmellose sodium, ferric oxide red (10 mg, 15 mg, 20 mg), ferric oxide yellow (2.5 mg), hypromellose, lactose monohydrate, magnesium stearate, polyethylene glycol, sodium lauryl sulfate, titanium dioxide

What dosage forms it comes in:

Film-coated tablets, 2.5 mg 10 mg, 15 mg and 20 mg.

For the treatment of a blood clot in the veins of your legs or lungs, a Starter Pack is available for the first 28 days of therapy. The Starter Pack includes 15 mg and 20 mg tablets.

WARNINGS AND PRECAUTIONS

Do not stop taking XARELTO without first talking to your doctor. If you stop taking XARELTO, blood clots may cause a stroke, heart attack, or other complications. This can be fatal or lead to severe disability.

As with other blood thinners, taking XARELTO may result in serious or life-threatening bleeding from any site, including internal organs.

Take special care when using XARELTO:

- if you have an increased risk of bleeding, as could be the case with conditions such as
 - bleeding disorders
 - very high blood pressure, not controlled by medical treatment
 - active ulcer or a recent ulcer of your stomach or bowel
 - a problem with the blood vessels in the back of your eyes (retinopathy)
 - recent bleeding in your brain (stroke, intracranial or intracerebral bleeding)
 - problems with the blood vessels in your brain or spinal column
 - a recent operation on your brain, spinal column or eye
 - a chronic disease of the airways in your lungs causing widening, damage and scarring (bronchiectasis), or a history of bleeding into your lungs
 - if you are older than 75 years of age
- if you have a prosthetic heart valve
- if a doctor has told you that you have antiphospholipid syndrome, a disease which can cause blood clots.

For the treatment and prevention of blood clots in the veins of your legs or lungs, XARELTO is not recommended if your doctor determines that:

- you are not able to maintain an adequate blood pressure
- you are taking drugs to break down your blood clots
- you have been scheduled for emergency surgical removal of blood clots from your lung

Tell your doctor before you take XARELTO, if any of these apply to you. Your doctor may decide to keep you under closer observation.

- If you are having surgery for any reason including an operation that involves a catheter or injection into your spinal column (eg, for epidural or spinal anesthesia or pain reduction):

- it is very important to take XARELTO before and after the procedure/injection or removal of a catheter exactly at the times you have been told by your doctor
- tell your doctor immediately if you get numbness or weakness of your legs, or problems with your bowel or bladder after the end of anesthesia, because urgent care is necessary

You should avoid XARELTO 2.5 mg if you have had a prior stroke with bleeding in the brain (hemorrhagic stroke) or a prior stroke where there was a blockage of the small arteries that provide blood to the brain's deep tissues (lacunar stroke).

You should avoid XARELTO 2.5 mg for at least one month after having a stroke from a blood clot in the brain (ischemic non-lacunar stroke).

Lactose is a nonmedicinal ingredient in XARELTO. Do not take XARELTO if a doctor has told you that you have one of the following rare hereditary diseases:

- Galactose intolerance
- Lapp lactase deficiency
- Glucose-galactose malabsorption

If you have severe kidney disease, you may not be able to take XARELTO because it may increase your chance of bleeding. Your doctor will know how to determine your kidney function.

XARELTO is not recommended if you have an artificial heart valve.

XARELTO is not recommended in children younger than 18 years old.

Pregnancy and breastfeeding

If there is a chance that you could become pregnant, use a reliable contraceptive while you are taking XARELTO. If you become pregnant while you are taking XARELTO, immediately tell your doctor, who will decide how you should be treated.

INTERACTIONS WITH THIS MEDICATION

Tell your doctor or pharmacist if you are taking:

- anticoagulants (blood thinners) such as warfarin, heparin or low molecular weight heparin (LMWH) including enoxaparin, fondaparinux, bivalirudin, apixaban, dabigatran, edoxaban, or anti-platelet agents, such as clopidogrel, ticlopidine, prasugrel, ticagrelor
- oral medications to treat fungal infections such as ketoconazole, itraconazole, posaconazole
- medications for HIV/AIDS such as ritonavir (NORVIR®) and lopinavir/ritonavir (KALETRA®)
- anti-inflammatory and pain relieving medicines including non-steroidal anti-inflammatory drugs (NSAIDs) (eg, naproxen [NAPROSYN®] or acetylsalicylic acid [ASPIRIN®])

- some antibiotics such as clarithromycin
- rifampicin
- anticonvulsants (to control seizures or fits) such as phenytoin, carbamazepine, phenobarbital
- medicines to treat depression and/or anxiety (selective serotonin reuptake inhibitors (SSRIs) or serotonin norepinephrine reuptake inhibitors (SNRIs))

You are at an increased risk for bleeding if you take XARELTO with:

- NSAIDs
- antiplatelet agents such as ASA or clopidogrel
- antidepressants/anti-anxiety (SSRIs, SNRIs)

Low-dose XARELTO 2.5 mg is prescribed together with low-dose ASA 75 mg – 100 mg. If you need to take another NSAID, your doctor will decide if it is beneficial for you to take it along with your XARELTO / ASA treatment.

The use of XARELTO with prasugrel or ticagrelor is not recommended.

Please tell your doctor or pharmacist if you are taking or have recently taken any other medication, including medications obtained without a prescription as well as vitamins and herbal supplements, such as St. John's Wort. Know the medicines you take. Keep a list of them and show it to your doctor and pharmacist when you get a new medicine.

PROPER USE OF THIS MEDICATION

If you are currently taking warfarin (another blood thinner taken by mouth) or receive other anticoagulant treatment given by injection, and your doctor has decided XARELTO is appropriate for you, make sure you ask your doctor exactly when and how best to switch and start taking XARELTO.

Always follow your doctor's instructions. Do not stop taking XARELTO without talking to your doctor first, because XARELTO helps prevent the development of blood clots.

Swallow the tablet preferably with water. Try to take the tablet at the same time every day to help you to remember it.

If you have trouble swallowing the tablet **whole**, talk to your doctor about other ways to take it.

The tablets may be crushed and mixed with applesauce. Take it right away after you have mixed it. A crushed 2.5 mg or 10 mg tablet can be taken with or without food. Eat food right after taking a crushed 15 mg or 20 mg tablet.

Your doctor may give you the crushed XARELTO tablet also via a tube.

Prevention of blood clots after major hip or knee surgery

Usual dose: 10 mg once a day with or without food.

Take the first tablet 6 to 10 hours after your operation. Then take a tablet every day until your doctor tells you to stop.

If you have had a major hip operation, you will usually take XARELTO for 35 days.

If you have had a major knee operation, you will usually take XARELTO for 14 days.

Prevention of blood clots in your brain (stroke) and in other blood vessels in your body if you have atrial fibrillation

Usual dose: 20 mg once a day with food.

If your kidneys are not working properly, your doctor may prescribe 15 mg once a day with food.

To be sure that you get the full benefit from XARELTO, it is important to take the 15 mg and 20 mg tablets with food.

If you need a procedure to treat blocked blood vessels in your heart (called a percutaneous coronary intervention – PCI with an insertion of a stent), your doctor will reduce your dose to 15 mg once a day (or to 10 mg once a day in case your kidneys are not working properly) in combination with an antiplatelet agent (eg, clopidogrel).

This is long-term treatment and you should continue to take XARELTO until your physician says otherwise.

The recommended maximum daily dose is 20 mg.

Treatment and prevention of blood clots in the veins of your legs or lungs

Swallow the tablet preferably with water.

Day 1 to 21:

- **15 mg:** Take 1 tablet TWICE a day (in the morning and evening) with food.

Day 22 onwards:

- **20 mg:** Take 1 tablet ONCE a day with food.

After at least 6 months treatment, your doctor may decide to continue treatment with either one 20 mg tablet once a day or one 10 mg tablet once a day.

The 10 mg tablet may be taken with or without food.

This is long-term treatment and you should continue to take XARELTO until your physician says otherwise.

Prevention of stroke, heart attack, sudden severe blockage of blood flow to your limbs, and risk of death if you have coronary artery disease (CAD) with or without peripheral artery disease (PAD).

Usual dose: 2.5 mg twice a day with or without food. Take XARELTO around the same time every day (for example, one tablet in the morning and one in the evening).

Also take 1 tablet of 75 mg – 100 mg of acetylsalicylic acid (ASA) once a day. Take the ASA tablet at the same time as one of your XARELTO doses.

This is long-term treatment and you should continue to take your treatment until your physician says otherwise.

Overdose

Taking too much XARELTO increases the risk of bleeding.

In case of drug overdose, contact a health care practitioner, hospital emergency department or regional Poison Control Centre immediately, even if there are no symptoms.

Missed Dose

If you are prescribed XARELTO 10 mg, 15 mg or 20 mg **once** a day and you have missed a dose, take it as soon as you remember. Take the next tablet on the following day at the usual time and then carry on taking a tablet once a day as normal. Do not take a double dose to make up for a forgotten tablet.

If you are prescribed XARELTO 15 mg **twice** a day and you have missed a dose, take it as soon as you remember. Do not take more than two 15 mg tablets on one day. If you forget to take a dose you can take two 15 mg tablets at the same time to get a total of two tablets (30 mg) on one day. On the following day you should carry on taking one 15 mg tablet twice a day.

If you are prescribed XARELTO 2.5 mg **twice** a day and you have missed a dose, take your next XARELTO 2.5 mg tablet as normal.

SIDE EFFECTS AND WHAT TO DO ABOUT THEM

Like all medicines, XARELTO can cause side effects, although not everybody gets them.

As XARELTO acts on the blood clotting system, most side effects are related to signs of bruising or bleeding. In some cases bleeding may not be obvious, such as unexplained swelling.

Patients treated with XARELTO may also experience the following side effects:

Nausea, vomiting, stomach ache, constipation, diarrhea, indigestion, and decreased general strength and energy.

SERIOUS SIDE EFFECTS, HOW OFTEN THEY HAPPEN AND WHAT TO DO ABOUT THEM

Symptom/ Effect	Talk with your doctor or pharmacist		Stop taking drug and seek immediate medical attention
	Only if severe	In all cases	
Common			
Bleeding from the surgical wound, an injury or other medical procedure		✓	
Unexpected bruising		✓	
Reduction in red blood cells which can make your skin pale and cause weakness, tiredness, dizziness, headache, breathlessness, unusually fast heartbeat, or chest pain		✓	
Bleeding into the eye	✓		
Bleeding from stomach (blood in vomit) or bowel (blood in stools/black stools)		✓	
Bleeding from hemorrhoids	✓		
Bleeding under the skin	✓		
Blood in your urine, (red/pink tinge to urine)		✓	
Genital bleeding in post menopausal women		✓	
Increased or more frequent menstrual bleeding	✓		
Localized swelling		✓	
Nose bleed lasting more than 5 minutes		✓	
Pain or swelling in your limbs		✓	
Low blood pressure (lightheaded-ness, dizziness, and/or fainting)		✓	
Fever		✓	
Unusually fast heartbeat		✓	

SERIOUS SIDE EFFECTS, HOW OFTEN THEY HAPPEN AND WHAT TO DO ABOUT THEM

Symptom/ Effect	Talk with your doctor or pharmacist		Stop taking drug and seek immediate medical attention
	Only if severe	In all cases	
Itchy skin or rash		✓	
Bleeding gums for longer than 5 minutes when you brush your teeth		✓	
Un-common	Bleeding into the brain (sudden, severe and unusual headache)		✓
	Coughing up blood		✓
	Bleeding into a joint (stiff, sore, hot or painful joint)		✓
	Oozing from the surgical wound		✓
	Decreased urine output	✓	
Rare	Liver Disorder: yellowing of the skin or eyes, dark urine, abdominal pain, nausea, vomiting, loss of appetite		✓
	Allergic Reaction: rash, hives, swelling of the face, lips, tongue or throat, and difficulty swallowing or breathing		✓
Unknown	Compartment Syndrome: increased pressure within legs or arms after a bleed, with pain, swelling, numbness or paralysis		✓
	Agranulocytosis [frequent infection with fever, sore throat, mouth ulcers (sign of decreased white blood cells)]		✓

SERIOUS SIDE EFFECTS, HOW OFTEN THEY HAPPEN AND WHAT TO DO ABOUT THEM

Symptom/ Effect	Talk with your doctor or pharmacist		Stop taking drug and seek immediate medical attention
	Only if severe	In all cases	
Stevens-Johnson syndrome: Severe skin rash with redness, blistering and/or peeling of the skin and/or inside of the lips, eyes, mouth, nasal passages or genitals, accompanied by fever, chills, headache, cough, body aches or swollen glands			✓

This is not a complete list of side effects. For any unexpected effects while taking XARELTO, contact your doctor or pharmacist.

HOW TO STORE IT

Keep at room temperature (15°C-30°C).

Keep out of the reach and sight of children.

Do not use XARELTO after the expiry date which is stated on the bottle and on each blister after EXP. The expiry date refers to the last day of that month.

Medicines should not be disposed of via wastewater or household waste. Ask your pharmacist how to throw away medicines you no longer use. These measures will help to protect the environment.

REPORTING SIDE EFFECTS

You can report any suspected side effects associated with the use of health products to Health Canada by:

- Visiting the Web page on Adverse Reaction Reporting (<https://www.canada.ca/en/health-canada/services/drugs-health-products/medeffect-canada/adverse-reaction-reporting.html>) for information on how to report online, by mail or by fax; or
- Calling toll-free at 1-866-234-2345.

NOTE: Contact your health professional if you need information about how to manage your side effects. The Canada Vigilance Program does not provide medical advice.

MORE INFORMATION

For more information, please contact your health professional or pharmacist first, or Bayer Inc. at 1-800-265-7382.

This document plus the full Product Monograph, prepared for health professionals can be found at: <http://www.bayer.ca> or by contacting the manufacturer at the above-mentioned phone number.

This leaflet was prepared by:



Bayer Inc.
2920 Matheson Boulevard East
Mississauga, Ontario, L4W 5R6
Canada

Last revised: September 20, 2019

© 2019, Bayer Inc.

® TM see www.bayer.ca/tm-mc

All other trademarks are the property of their respective owners.

Bayer

HIGHLIGHTS OF PRESCRIBING INFORMATION

These highlights do not include all the information needed to use XARELTO® (rivaroxaban) safely and effectively. See full prescribing information for XARELTO.

XARELTO (rivaroxaban) tablets, for oral use
Initial U.S. Approval: 2011

WARNING: (A) PREMATURE DISCONTINUATION OF XARELTO INCREASES THE RISK OF THROMBOTIC EVENTS, (B) SPINAL/EPIDURAL HEMATOMA

See full prescribing information for complete boxed warning.

(A) Premature discontinuation of XARELTO increases the risk of thrombotic events

Premature discontinuation of any oral anticoagulant, including XARELTO, increases the risk of thrombotic events. To reduce this risk, consider coverage with another anticoagulant if XARELTO is discontinued for a reason other than pathological bleeding or completion of a course of therapy. (2.2, 2.3, 5.1, 14.1)

(B) Spinal/epidural hematoma

Epidural or spinal hematomas have occurred in patients treated with XARELTO who are receiving neuraxial anesthesia or undergoing spinal puncture. These hematomas may result in long-term or permanent paralysis. (5.2, 5.3, 6.2)

Monitor patients frequently for signs and symptoms of neurological impairment and if observed, treat urgently. Consider the benefits and risks before neuraxial intervention in patients who are or who need to be anticoagulated. (5.3)

-----RECENT MAJOR CHANGES-----

Indications and Usage (1.6)	10/2019
Dosage and Administration (2.1)	11/2019
Warnings and Precautions (5.2, 5.10)	10/2019
Warnings and Precautions (5.4)	11/2019
Warnings and Precautions (5.8)	03/2020

-----INDICATIONS AND USAGE-----

XARELTO is a factor Xa inhibitor indicated:

- to reduce risk of stroke and systemic embolism in nonvalvular atrial fibrillation (1.1)
- for treatment of deep vein thrombosis (DVT) (1.2)
- for treatment of pulmonary embolism (PE) (1.3)
- for reduction in the risk of recurrence of DVT or PE (1.4)
- for the prophylaxis of DVT, which may lead to PE in patients undergoing knee or hip replacement surgery (1.5)
- for prophylaxis of venous thromboembolism (VTE) in acutely ill medical patients (1.6)
- to reduce the risk of major cardiovascular events in patients with chronic coronary artery disease (CAD) or peripheral artery disease (PAD) (1.7)

-----DOSAGE AND ADMINISTRATION-----

- **Nonvalvular Atrial Fibrillation:** 15 or 20 mg, once daily with food (2.1)
- **Treatment of DVT and/or PE:** 15 mg orally twice daily with food for the first 21 days followed by 20 mg orally once daily with food for the remaining treatment (2.1)
- **Reduction in the Risk of Recurrence of DVT and/or PE in patients at continued risk for DVT and/or PE:** 10 mg once daily with or without food, after at least 6 months of standard anticoagulant treatment (2.1)
- **Prophylaxis of DVT Following Hip or Knee Replacement Surgery:** 10 mg orally once daily with or without food (2.1)
- **Prophylaxis of VTE in Acutely Ill Medical Patients at Risk for Thromboembolic Complications Not at High Risk of Bleeding:** 10 mg once daily, with or without food, in hospital and after hospital discharge for a total recommended duration of 31 to 39 days (2.1)
- **CAD or PAD:** 2.5 mg orally twice daily with or without food, in combination with aspirin (75-100 mg) once daily (2.1)

-----DOSAGE FORMS AND STRENGTHS-----

Tablets: 2.5 mg, 10 mg, 15 mg, and 20 mg (3)

-----CONTRAINDICATIONS-----

- Active pathological bleeding (4)
- Severe hypersensitivity reaction to XARELTO (4)

-----WARNINGS AND PRECAUTIONS-----

- Risk of bleeding: XARELTO can cause serious and fatal bleeding. An agent to reverse the activity of rivaroxaban is available. (5.2)
- Pregnancy-related hemorrhage: Use XARELTO with caution in pregnant women due to the potential for obstetric hemorrhage and/or emergent delivery. (5.7, 8.1)
- Prosthetic heart valves: XARELTO use not recommended (5.8)
- Increased Risk of Thrombosis in Patients with Triple Positive Antiphospholipid Syndrome: XARELTO use not recommended. (5.10)

-----ADVERSE REACTIONS-----

The most common adverse reaction (>5%) was bleeding. (6.1)

To report SUSPECTED ADVERSE REACTIONS, contact Janssen Pharmaceuticals, Inc. at 1-800-526-7736 or FDA at 1-800-FDA-1088 or www.fda.gov/medwatch.

-----DRUG INTERACTIONS-----

- Avoid combined P-gp and strong CYP3A inhibitors and inducers (7.2, 7.3)
- Anticoagulants: Avoid concomitant use (7.4)

-----USE IN SPECIFIC POPULATIONS-----

- Renal impairment: Avoid or adjust dose (8.6)
- Hepatic impairment: Avoid use in Child-Pugh B and C hepatic impairment or hepatic disease associated with coagulopathy (8.7)

See 17 for PATIENT COUNSELING INFORMATION and Medication Guide.

Revised: 03/2020

FULL PRESCRIBING INFORMATION: CONTENTS*

WARNING: (A) PREMATURE DISCONTINUATION OF XARELTO INCREASES THE RISK OF THROMBOTIC EVENTS, (B) SPINAL/EPIDURAL HEMATOMA

1 INDICATIONS AND USAGE

- 1.1 Reduction of Risk of Stroke and Systemic Embolism in Nonvalvular Atrial Fibrillation
- 1.2 Treatment of Deep Vein Thrombosis
- 1.3 Treatment of Pulmonary Embolism
- 1.4 Reduction in the Risk of Recurrence of Deep Vein Thrombosis and/or Pulmonary Embolism
- 1.5 Prophylaxis of Deep Vein Thrombosis Following Hip or Knee Replacement Surgery
- 1.6 Prophylaxis of Venous Thromboembolism in Acutely Ill Medical Patients at Risk for Thromboembolic Complications Not at High Risk of Bleeding

- 1.7 Reduction of Risk of Major Cardiovascular Events in Patients with Chronic Coronary Artery Disease (CAD) or Peripheral Artery Disease (PAD)

2 DOSAGE AND ADMINISTRATION

- 2.1 Recommended Dosage
- 2.2 Switching to and from XARELTO
- 2.3 Discontinuation for Surgery and other Interventions
- 2.4 Missed Dose
- 2.5 Administration Options

3 DOSAGE FORMS AND STRENGTHS

4 CONTRAINDICATIONS

5 WARNINGS AND PRECAUTIONS

- 5.1 Increased Risk of Thrombotic Events after Premature Discontinuation
- 5.2 Risk of Bleeding
- 5.3 Spinal/Epidural Anesthesia or Puncture
- 5.4 Use in Patients with Renal Impairment
- 5.5 Use in Patients with Hepatic Impairment
- 5.6 Use with P-gp and Strong CYP3A Inhibitors or Inducers
- 5.7 Risk of Pregnancy-Related Hemorrhage

- 5.8 Patients with Prosthetic Heart Valves
- 5.9 Acute PE in Hemodynamically Unstable Patients or Patients Who Require Thrombolysis or Pulmonary Embolectomy
- 5.10 Increased Risk of Thrombosis in Patients with Triple Positive Antiphospholipid Syndrome

6 ADVERSE REACTIONS

- 6.1 Clinical Trials Experience
- 6.2 Postmarketing Experience

7 DRUG INTERACTIONS

- 7.1 General Inhibition and Induction Properties
- 7.2 Drugs that Inhibit Cytochrome P450 3A Enzymes and Drug Transport Systems
- 7.3 Drugs that Induce Cytochrome P450 3A Enzymes and Drug Transport Systems
- 7.4 Anticoagulants and NSAIDs/Aspirin

8 USE IN SPECIFIC POPULATIONS

- 8.1 Pregnancy
- 8.2 Lactation
- 8.3 Females and Males of Reproductive Potential
- 8.4 Pediatric Use
- 8.5 Geriatric Use
- 8.6 Renal Impairment
- 8.7 Hepatic Impairment

10 OVERDOSAGE

11 DESCRIPTION

12 CLINICAL PHARMACOLOGY

- 12.1 Mechanism of Action
- 12.2 Pharmacodynamics
- 12.3 Pharmacokinetics
- 12.6 QT/QTc Prolongation

13 NON-CLINICAL TOXICOLOGY

- 13.1 Carcinogenesis, Mutagenesis, Impairment of Fertility

14 CLINICAL STUDIES

- 14.1 Stroke Prevention in Nonvalvular Atrial Fibrillation
- 14.2 Treatment of Deep Vein Thrombosis (DVT) and/or Pulmonary Embolism (PE)
- 14.3 Reduction in the Risk of Recurrence of DVT and/or PE
- 14.4 Prophylaxis of Deep Vein Thrombosis Following Hip or Knee Replacement Surgery
- 14.5 Prophylaxis of Venous Thromboembolism in Acutely Ill Medical Patients at Risk for Thromboembolic Complications Not at High Risk of Bleeding
- 14.6 Reduction of Risk of Major Cardiovascular Events in Patients with Chronic CAD or PAD

16 HOW SUPPLIED/STORAGE AND HANDLING

17 PATIENT COUNSELING INFORMATION

*Sections or subsections omitted from the full prescribing information are not listed.

FULL PRESCRIBING INFORMATION

WARNING: (A) PREMATURE DISCONTINUATION OF XARELTO INCREASES THE RISK OF THROMBOTIC EVENTS, (B) SPINAL/EPIDURAL HEMATOMA

A. Premature discontinuation of XARELTO increases the risk of thrombotic events

Premature discontinuation of any oral anticoagulant, including XARELTO, increases the risk of thrombotic events. If anticoagulation with XARELTO is discontinued for a reason other than pathological bleeding or completion of a course of therapy, consider coverage with another anticoagulant [see *Dosage and Administration* (2.2, 2.3), *Warnings and Precautions* (5.1), and *Clinical Studies* (14.1)].

B. Spinal/epidural hematoma

Epidural or spinal hematomas have occurred in patients treated with XARELTO who are receiving neuraxial anesthesia or undergoing spinal puncture. These hematomas may result in long-term or permanent paralysis. Consider these risks when scheduling patients for spinal procedures. Factors that can increase the risk of developing epidural or spinal hematomas in these patients include:

- use of indwelling epidural catheters
- concomitant use of other drugs that affect hemostasis, such as non-steroidal anti-inflammatory drugs (NSAIDs), platelet inhibitors, other anticoagulants
- a history of traumatic or repeated epidural or spinal punctures
- a history of spinal deformity or spinal surgery
- optimal timing between the administration of XARELTO and neuraxial procedures is not known

[see *Warnings and Precautions* (5.2, 5.3) and *Adverse Reactions* (6.2)].

Monitor patients frequently for signs and symptoms of neurological impairment. If neurological compromise is noted, urgent treatment is necessary [see *Warnings and Precautions* (5.3)].

Consider the benefits and risks before neuraxial intervention in patients anticoagulated or to be anticoagulated for thromboprophylaxis [see *Warnings and Precautions* (5.3)].

1 INDICATIONS AND USAGE

1.1 Reduction of Risk of Stroke and Systemic Embolism in Nonvalvular Atrial Fibrillation

XARELTO is indicated to reduce the risk of stroke and systemic embolism in patients with nonvalvular atrial fibrillation.

There are limited data on the relative effectiveness of XARELTO and warfarin in reducing the risk of stroke and systemic embolism when warfarin therapy is well-controlled [*see Clinical Studies (14.1)*].

1.2 Treatment of Deep Vein Thrombosis

XARELTO is indicated for the treatment of deep vein thrombosis (DVT).

1.3 Treatment of Pulmonary Embolism

XARELTO is indicated for the treatment of pulmonary embolism (PE).

1.4 Reduction in the Risk of Recurrence of Deep Vein Thrombosis and/or Pulmonary Embolism

XARELTO is indicated for the reduction in the risk of recurrence of DVT and/or PE in patients at continued risk for recurrent DVT and/or PE after completion of initial treatment lasting at least 6 months.

1.5 Prophylaxis of Deep Vein Thrombosis Following Hip or Knee Replacement Surgery

XARELTO is indicated for the prophylaxis of DVT, which may lead to PE in patients undergoing knee or hip replacement surgery.

1.6 Prophylaxis of Venous Thromboembolism in Acutely Ill Medical Patients at Risk for Thromboembolic Complications Not at High Risk of Bleeding

XARELTO is indicated for the prophylaxis of venous thromboembolism (VTE) and VTE related death during hospitalization and post hospital discharge in adult patients admitted for an acute medical illness who are at risk for thromboembolic complications due to moderate or severe restricted mobility and other risk factors for VTE and not at high risk of bleeding [*see Warnings and Precautions (5.2) and Clinical Studies (14.1)*].

1.7 Reduction of Risk of Major Cardiovascular Events in Patients with Chronic Coronary Artery Disease (CAD) or Peripheral Artery Disease (PAD)

XARELTO, in combination with aspirin, is indicated to reduce the risk of major cardiovascular events (cardiovascular (CV) death, myocardial infarction (MI) and stroke) in patients with chronic coronary artery disease (CAD) or peripheral artery disease (PAD).

2 DOSAGE AND ADMINISTRATION

2.1 Recommended Dosage

Table 1: Recommended Dosage

Indication	Renal Considerations*	Dosage	Food/Timing†
Reduction in Risk of Stroke in Nonvalvular Atrial Fibrillation	CrCl >50 mL/min	20 mg once daily	Take with evening meal
	CrCl ≤50 mL/min§	15 mg once daily	Take with evening meal
Treatment of DVT and/or PE	CrCl ≥15 mL/min§	15 mg <u>twice daily</u> ▼ after 21 days, transition to ▼ 20 mg <u>once daily</u>	Take with food, at the same time each day
	CrCl <15 mL/min	Avoid Use	
Reduction in the Risk of Recurrence of DVT and/or PE in patients at continued risk for DVT and/or PE	CrCl ≥15 mL/min§	10 mg once daily, after at least 6 months of standard anticoagulant treatment	Take with or without food
	CrCl <15 mL/min	Avoid Use	
Prophylaxis of DVT Following:			
- Hip Replacement Surgery‡	CrCl ≥15 mL/min§	10 mg once daily for 35 days, 6-10 hours after surgery once hemostasis has been established	Take with or without food
	CrCl <15 mL/min	Avoid Use	
- Knee Replacement Surgery‡	CrCl ≥15 mL/min§	10 mg once daily for 12 days, 6-10 hours after surgery once hemostasis has been established	Take with or without food
	CrCl <15 mL/min	Avoid Use	
Prophylaxis of VTE in Acutely Ill Medical Patients at Risk for Thromboembolic Complications Not at High Risk of Bleeding	CrCl ≥15 mL/min§	10 mg once daily, in hospital and after hospital discharge, for a total recommended duration of 31 to 39 days	Take with or without food
	CrCl <15 mL/min	Avoid Use	
Reduction of Risk of Major Cardiovascular Events (CV Death, MI, and Stroke) in Chronic CAD or PAD	No dose adjustment needed based on CrCl	2.5 mg <u>twice daily</u> , plus aspirin (75-100 mg) once daily	Take with or without food

* Calculate CrCl based on actual weight. See Warnings and Precautions (5.4) and Use in Specific Populations (8.6)

† See Clinical Pharmacology (12.3)

‡ See Dosage and Administration (2.3)

§ Patients with CrCl <30 mL/min were not studied, but administration of XARELTO is expected to result in serum concentrations of rivaroxaban similar to those in patients with moderate renal impairment (CrCl 30 to <50 mL/min) [see Use in Specific Populations (8.6)]

2.2 Switching to and from XARELTO

Switching from Warfarin to XARELTO - When switching patients from warfarin to XARELTO, discontinue warfarin and start XARELTO as soon as the International Normalized Ratio (INR) is below 3.0 to avoid periods of inadequate anticoagulation.

Switching from XARELTO to Warfarin - No clinical trial data are available to guide converting patients from XARELTO to warfarin. XARELTO affects INR, so INR measurements made during coadministration with warfarin may not be useful for determining the appropriate dose of warfarin. One approach is to discontinue XARELTO and begin both a parenteral anticoagulant and warfarin at the time the next dose of XARELTO would have been taken.

Switching from XARELTO to Anticoagulants other than Warfarin - For patients currently taking XARELTO and transitioning to an anticoagulant with rapid onset, discontinue XARELTO and give the first dose of the other anticoagulant (oral or parenteral) at the time that the next XARELTO dose would have been taken [*see Drug Interactions (7.4)*].

Switching from Anticoagulants other than Warfarin to XARELTO - For patients currently receiving an anticoagulant other than warfarin, start XARELTO 0 to 2 hours prior to the next scheduled evening administration of the drug (e.g., low molecular weight heparin or non-warfarin oral anticoagulant) and omit administration of the other anticoagulant. For unfractionated heparin being administered by continuous infusion, stop the infusion and start XARELTO at the same time.

2.3 Discontinuation for Surgery and other Interventions

If anticoagulation must be discontinued to reduce the risk of bleeding with surgical or other procedures, XARELTO should be stopped at least 24 hours before the procedure to reduce the risk of bleeding [*see Warnings and Precautions (5.2)*]. In deciding whether a procedure should be delayed until 24 hours after the last dose of XARELTO, the increased risk of bleeding should be weighed against the urgency of intervention. XARELTO should be restarted after the surgical or other procedures as soon as adequate hemostasis has been established, noting that the time to onset of therapeutic effect is short [*see Warnings and Precautions (5.1)*]. If oral medication cannot be taken during or after surgical intervention, consider administering a parenteral anticoagulant.

2.4 Missed Dose

- For patients receiving 2.5 mg twice daily: if a dose is missed, the patient should take a single 2.5 mg XARELTO dose as recommended at the next scheduled time.

- For patients receiving 15 mg twice daily: The patient should take XARELTO immediately to ensure intake of 30 mg XARELTO per day. Two 15 mg tablets may be taken at once.
- For patients receiving 20 mg, 15 mg or 10 mg once daily: The patient should take the missed XARELTO dose immediately. The dose should not be doubled within the same day to make up for a missed dose.

2.5 Administration Options

For patients who are unable to swallow whole tablets, XARELTO tablets (all strengths) may be crushed and mixed with applesauce immediately prior to use and administered orally. After the administration of a crushed XARELTO 15 mg or 20 mg tablet, the dose should be immediately followed by food. Administration with food is not required for the 2.5 mg or 10 mg tablets [*see Clinical Pharmacology (12.3)*].

Administration via nasogastric (NG) tube or gastric feeding tube: After confirming gastric placement of the tube, XARELTO tablets (all strengths) may be crushed and suspended in 50 mL of water and administered via an NG tube or gastric feeding tube. Since rivaroxaban absorption is dependent on the site of drug release, avoid administration of XARELTO distal to the stomach which can result in reduced absorption and thereby, reduced drug exposure. After the administration of a crushed XARELTO 15 mg or 20 mg tablet, the dose should then be immediately followed by enteral feeding. Enteral feeding is not required following administration of the 2.5 mg or 10 mg tablets [*see Clinical Pharmacology (12.3)*].

Crushed XARELTO tablets (all strengths) are stable in water and in applesauce for up to 4 hours. An *in vitro* compatibility study indicated that there is no adsorption of rivaroxaban from a water suspension of a crushed XARELTO tablet to PVC or silicone nasogastric (NG) tubing.

3 DOSAGE FORMS AND STRENGTHS

- 2.5 mg tablets: Round, light yellow, and film-coated with a triangle pointing down above a “2.5” marked on one side and “Xa” on the other side
- 10 mg tablets: Round, light red, biconvex and film-coated with a triangle pointing down above a “10” marked on one side and “Xa” on the other side
- 15 mg tablets: Round, red, biconvex, and film-coated with a triangle pointing down above a “15” marked on one side and “Xa” on the other side
- 20 mg tablets: Triangle-shaped, dark red, and film-coated with a triangle pointing down above a “20” marked on one side and “Xa” on the other side

4 CONTRAINDICATIONS

XARELTO is contraindicated in patients with:

- active pathological bleeding [*see Warnings and Precautions (5.2)*]

- severe hypersensitivity reaction to XARELTO (e.g., anaphylactic reactions) [*see Adverse Reactions (6.2)*]

5 WARNINGS AND PRECAUTIONS

5.1 Increased Risk of Thrombotic Events after Premature Discontinuation

Premature discontinuation of any oral anticoagulant, including XARELTO, in the absence of adequate alternative anticoagulation increases the risk of thrombotic events. An increased rate of stroke was observed during the transition from XARELTO to warfarin in clinical trials in atrial fibrillation patients. If XARELTO is discontinued for a reason other than pathological bleeding or completion of a course of therapy, consider coverage with another anticoagulant [*see Dosage and Administration (2.2, 2.3) and Clinical Studies (14.1)*].

5.2 Risk of Bleeding

XARELTO increases the risk of bleeding and can cause serious or fatal bleeding. In deciding whether to prescribe XARELTO to patients at increased risk of bleeding, the risk of thrombotic events should be weighed against the risk of bleeding.

Promptly evaluate any signs or symptoms of blood loss and consider the need for blood replacement. Discontinue XARELTO in patients with active pathological hemorrhage. The terminal elimination half-life of rivaroxaban is 5 to 9 hours in healthy subjects aged 20 to 45 years.

Concomitant use of other drugs that impair hemostasis increases the risk of bleeding. These include aspirin, P2Y₁₂ platelet inhibitors, dual antiplatelet therapy, other antithrombotic agents, fibrinolytic therapy, non-steroidal anti-inflammatory drugs (NSAIDs) [*see Drug Interactions (7.4)*], selective serotonin reuptake inhibitors, and serotonin norepinephrine reuptake inhibitors.

Concomitant use of drugs that are known combined P-gp and strong CYP3A inhibitors increases rivaroxaban exposure and may increase bleeding risk [*see Drug Interactions (7.2)*].

Risk of Hemorrhage in Acutely Ill Medical Patients at High Risk of Bleeding

Acutely ill medical patients with the following conditions are at increased risk of bleeding with the use of XARELTO for primary VTE prophylaxis: history of bronchiectasis, pulmonary cavitation, or pulmonary hemorrhage, active cancer (i.e. undergoing acute, in-hospital cancer treatment), active gastroduodenal ulcer in the three months prior to treatment, history of bleeding in the three months prior to treatment, or dual antiplatelet therapy. XARELTO is not for use for primary VTE prophylaxis in these hospitalized, acutely ill medical patients at high risk of bleeding.

Reversal of Anticoagulant Effect

An agent to reverse the anti-factor Xa activity of rivaroxaban is available. Because of high plasma protein binding, rivaroxaban is not dialyzable [see *Clinical Pharmacology (12.3)*]. Protamine sulfate and vitamin K are not expected to affect the anticoagulant activity of rivaroxaban. Use of procoagulant reversal agents, such as prothrombin complex concentrate (PCC), activated prothrombin complex concentrate or recombinant factor VIIa, may be considered but has not been evaluated in clinical efficacy and safety studies. Monitoring for the anticoagulation effect of rivaroxaban using a clotting test (PT, INR or aPTT) or anti-factor Xa (FXa) activity is not recommended.

5.3 Spinal/Epidural Anesthesia or Puncture

When neuraxial anesthesia (spinal/epidural anesthesia) or spinal puncture is employed, patients treated with anticoagulant agents for prevention of thromboembolic complications are at risk of developing an epidural or spinal hematoma which can result in long-term or permanent paralysis [see *Boxed Warning*].

To reduce the potential risk of bleeding associated with the concurrent use of XARELTO and epidural or spinal anesthesia/analgesia or spinal puncture, consider the pharmacokinetic profile of XARELTO [see *Clinical Pharmacology (12.3)*]. Placement or removal of an epidural catheter or lumbar puncture is best performed when the anticoagulant effect of XARELTO is low; however, the exact timing to reach a sufficiently low anticoagulant effect in each patient is not known.

An indwelling epidural or intrathecal catheter should not be removed before at least 2 half-lives have elapsed (i.e., 18 hours in young patients aged 20 to 45 years and 26 hours in elderly patients aged 60 to 76 years), after the last administration of XARELTO [see *Clinical Pharmacology (12.3)*]. The next XARELTO dose should not be administered earlier than 6 hours after the removal of the catheter. If traumatic puncture occurs, delay the administration of XARELTO for 24 hours.

Should the physician decide to administer anticoagulation in the context of epidural or spinal anesthesia/analgesia or lumbar puncture, monitor frequently to detect any signs or symptoms of neurological impairment, such as midline back pain, sensory and motor deficits (numbness, tingling, or weakness in lower limbs), bowel and/or bladder dysfunction. Instruct patients to immediately report if they experience any of the above signs or symptoms. If signs or symptoms of spinal hematoma are suspected, initiate urgent diagnosis and treatment including consideration for spinal cord decompression even though such treatment may not prevent or reverse neurological sequelae.

5.4 Use in Patients with Renal Impairment

Nonvalvular Atrial Fibrillation

Periodically assess renal function as clinically indicated (i.e., more frequently in situations in which renal function may decline) and adjust therapy accordingly [*see Dosage and Administration (2.1)*]. Consider dose adjustment or discontinuation of XARELTO in patients who develop acute renal failure while on XARELTO [*see Use in Specific Populations (8.6)*].

Treatment of Deep Vein Thrombosis (DVT), Pulmonary Embolism (PE), and Reduction in the Risk of Recurrence of DVT and of PE

In patients with CrCl <30 mL/min, rivaroxaban exposure and pharmacodynamic effects are increased compared to patients with normal renal function. There are limited clinical data in patients with CrCl 15 to <30 mL/min; therefore, observe closely and promptly evaluate any signs or symptoms of blood loss in these patients. There are no clinical data in patients with CrCl <15 mL/min (including patients on dialysis); therefore, avoid the use of XARELTO in these patients.

Discontinue XARELTO in patients who develop acute renal failure while on treatment [*see Use in Specific Populations (8.6)*].

Prophylaxis of Deep Vein Thrombosis Following Hip or Knee Replacement Surgery

In patients with CrCl <30 mL/min, rivaroxaban exposure and pharmacodynamic effects are increased compared to patients with normal renal function. There are limited clinical data in patients with CrCl 15 to <30 mL/min; therefore, observe closely and promptly evaluate any signs or symptoms of blood loss in these patients. There are no clinical data in patients with CrCl <15 mL/min (including patients on dialysis); therefore, avoid the use of XARELTO in these patients.

Discontinue XARELTO in patients who develop acute renal failure while on treatment [*see Use in Specific Populations (8.6)*].

Prophylaxis of Venous Thromboembolism in Acutely Ill Medical Patients at Risk for Thromboembolic Complications Not at High Risk of Bleeding

In patients with CrCl <30 mL/min, rivaroxaban exposure and pharmacodynamic effects are increased compared to patients with normal renal function. There are limited clinical data in patients with CrCl 15 to <30 mL/min; therefore, observe closely and promptly evaluate any signs or symptoms of blood loss in these patients. There are no clinical data in patients with CrCl <15 mL/min (including patients on dialysis); therefore, avoid the use of XARELTO in these patients.

Discontinue XARELTO in patients who develop acute renal failure while on treatment [*see Use in Specific Populations (8.6)*].

5.5 Use in Patients with Hepatic Impairment

No clinical data are available for patients with severe hepatic impairment.

Avoid use of XARELTO in patients with moderate (Child-Pugh B) and severe (Child-Pugh C) hepatic impairment or with any hepatic disease associated with coagulopathy since drug exposure and bleeding risk may be increased [*see Use in Specific Populations (8.7)*].

5.6 Use with P-gp and Strong CYP3A Inhibitors or Inducers

Avoid concomitant use of XARELTO with known combined P-gp and strong CYP3A inhibitors [*see Drug Interactions (7.2)*].

Avoid concomitant use of XARELTO with drugs that are known combined P-gp and strong CYP3A inducers [*see Drug Interactions (7.3)*].

5.7 Risk of Pregnancy-Related Hemorrhage

In pregnant women, XARELTO should be used only if the potential benefit justifies the potential risk to the mother and fetus. XARELTO dosing in pregnancy has not been studied. The anticoagulant effect of XARELTO cannot be monitored with standard laboratory testing. Promptly evaluate any signs or symptoms suggesting blood loss (e.g., a drop in hemoglobin and/or hematocrit, hypotension, or fetal distress) [*see Warnings and Precautions (5.2) and Use in Specific Populations (8.1)*].

5.8 Patients with Prosthetic Heart Valves

On the basis of the GALILEO study, use of XARELTO is not recommended in patients who have had transcatheter aortic valve replacement (TAVR) because patients randomized to XARELTO experienced higher rates of death and bleeding compared to those randomized to an anti-platelet regimen. The safety and efficacy of XARELTO have not been studied in patients with other prosthetic heart valves or other valve procedures. Use of XARELTO is not recommended in patients with prosthetic heart valves.

5.9 Acute PE in Hemodynamically Unstable Patients or Patients Who Require Thrombolysis or Pulmonary Embolectomy

Initiation of XARELTO is not recommended acutely as an alternative to unfractionated heparin in patients with pulmonary embolism who present with hemodynamic instability or who may receive thrombolysis or pulmonary embolectomy.

5.10 Increased Risk of Thrombosis in Patients with Triple Positive Antiphospholipid Syndrome

Direct-acting oral anticoagulants (DOACs), including XARELTO, are not recommended for use in patients with triple-positive antiphospholipid syndrome (APS). For patients with APS (especially those who are triple positive [positive for lupus anticoagulant, anticardiolipin, and anti-beta 2-glycoprotein I antibodies]), treatment with DOACs has been associated with increased rates of recurrent thrombotic events compared with vitamin K antagonist therapy.

6 ADVERSE REACTIONS

The following clinically significant adverse reactions are also discussed in other sections of the labeling:

- Increased Risk of Stroke After Discontinuation in Nonvalvular Atrial Fibrillation [*see Boxed Warning and Warnings and Precautions (5.1)*]
- Bleeding Risk [*see Warnings and Precautions (5.2, 5.4, 5.5, 5.6, 5.7)*]
- Spinal/Epidural Hematoma [*see Boxed Warning and Warnings and Precautions (5.3)*]

6.1 Clinical Trials Experience

Because clinical trials are conducted under widely varying conditions, adverse reaction rates observed in the clinical trials of a drug cannot be directly compared to rates in the clinical trials of another drug and may not reflect the rates observed in clinical practice.

During clinical development for the approved indications, 31,691 patients were exposed to XARELTO. These included 7111 patients who received XARELTO 15 mg or 20 mg orally once daily for a mean of 19 months (5558 for 12 months and 2512 for 24 months) to reduce the risk of stroke and systemic embolism in nonvalvular atrial fibrillation (ROCKET AF); 6962 patients

who received XARELTO 15 mg orally twice daily for three weeks followed by 20 mg orally once daily to treat DVT or PE (EINSTEIN DVT, EINSTEIN PE), 10 mg or 20 mg orally once daily (EINSTEIN Extension, EINSTEIN CHOICE) to reduce the risk of recurrence of DVT and/or PE; 4487 patients who received XARELTO 10 mg orally once daily for prophylaxis of DVT following hip or knee replacement surgery (RECORD 1-3); 3997 patients who received 10 mg orally once daily for prophylaxis of VTE and VTE-related death in acutely ill medical patients (MAGELLAN) and 9134 patients who received XARELTO 2.5 mg orally twice daily, in combination with aspirin 100 mg once daily, for the reduction in risk of major cardiovascular events in patients with chronic CAD or PAD (COMPASS).

Hemorrhage

The most common adverse reactions with XARELTO were bleeding complications [see *Warnings and Precautions (5.2)*].

Nonvalvular Atrial Fibrillation

In the ROCKET AF trial, the most frequent adverse reactions associated with permanent drug discontinuation were bleeding events, with incidence rates of 4.3% for XARELTO vs. 3.1% for warfarin. The incidence of discontinuations for non-bleeding adverse events was similar in both treatment groups.

Table 2 shows the number of patients experiencing various types of bleeding events in the ROCKET AF trial.

Table 2: Bleeding Events in ROCKET AF*- On Treatment Plus 2 Days

Parameter	XARELTO N=7111 n (%/year)	Warfarin N=7125 n (%/year)	XARELTO vs. Warfarin HR (95% CI)
Major Bleeding [†]	395 (3.6)	386 (3.5)	1.04 (0.90, 1.20)
Intracranial Hemorrhage (ICH) [‡]	55 (0.5)	84 (0.7)	0.67 (0.47, 0.93)
Hemorrhagic Stroke [§]	36 (0.3)	58 (0.5)	0.63 (0.42, 0.96)
Other ICH	19 (0.2)	26 (0.2)	0.74 (0.41, 1.34)
Gastrointestinal (GI) [¶]	221 (2.0)	140 (1.2)	1.61 (1.30, 1.99)
Fatal Bleeding [#]	27 (0.2)	55 (0.5)	0.50 (0.31, 0.79)
ICH	24 (0.2)	42 (0.4)	0.58 (0.35, 0.96)
Non-intracranial	3 (0.0)	13 (0.1)	0.23 (0.07, 0.82)

Abbreviations: HR = Hazard Ratio, CI = Confidence interval, CRNM = Clinically Relevant Non-Major.

* Major bleeding events within each subcategory were counted once per patient, but patients may have contributed events to multiple subcategories. These events occurred during treatment or within 2 days of stopping treatment.

[†] Defined as clinically overt bleeding associated with a decrease in hemoglobin of ≥ 2 g/dL, a transfusion of ≥ 2 units of packed red blood cells or whole blood, bleeding at a critical site, or with a fatal outcome.

[‡] Intracranial bleeding events included intraparenchymal, intraventricular, subdural, subarachnoid and/or epidural hematoma.

§ Hemorrhagic stroke in this table specifically refers to non-traumatic intraparenchymal and/or intraventricular hematoma in patients on treatment plus 2 days.

¶ Gastrointestinal bleeding events included upper GI, lower GI, and rectal bleeding.

Fatal bleeding is adjudicated death with the primary cause of death from bleeding.

Figure 1 shows the risk of major bleeding events across major subgroups.

Figure 1: Risk of Major Bleeding Events by Baseline Characteristics in ROCKET AF – On Treatment Plus 2 Days

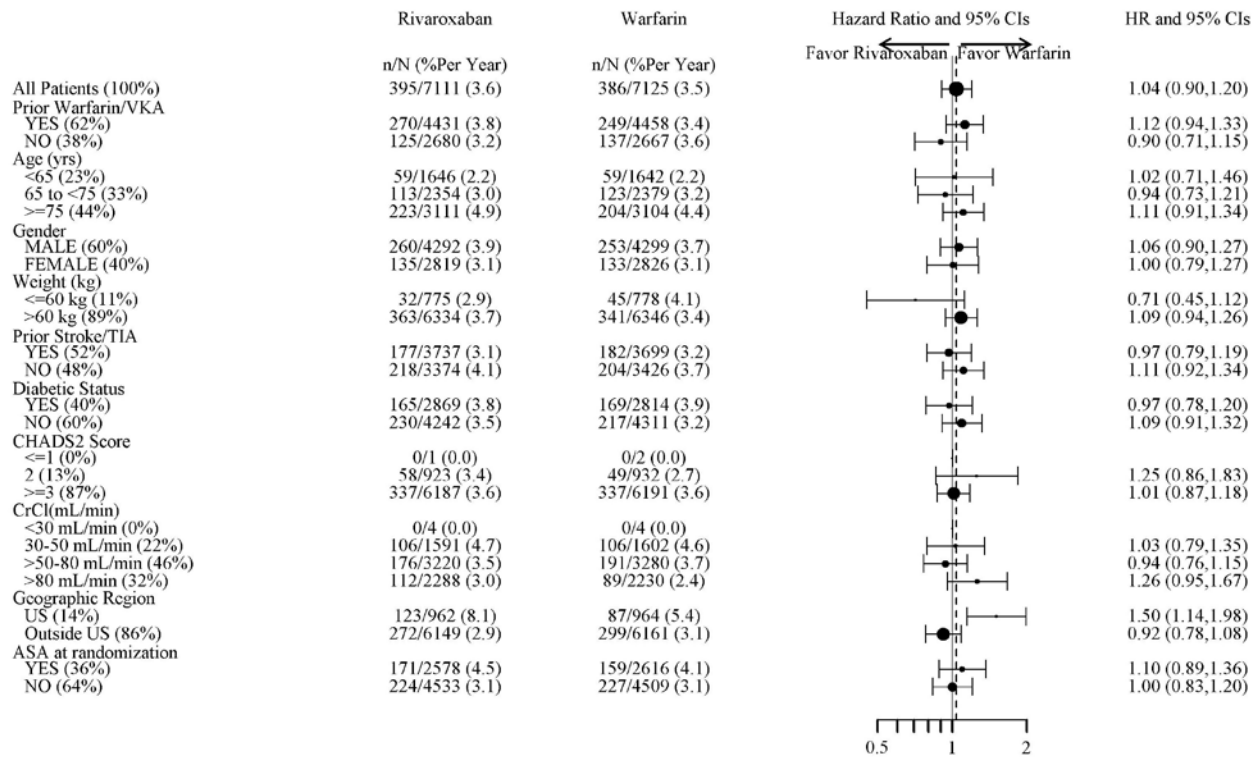

Note: The figure above presents effects in various subgroups all of which are baseline characteristics and all of which were pre-specified (diabetic status was not pre-specified in the subgroup but was a criterion for the CHADS2 score). The 95% confidence limits that are shown do not take into account how many comparisons were made, nor do they reflect the effect of a particular factor after adjustment for all other factors. Apparent homogeneity or heterogeneity among groups should not be over-interpreted.

Treatment of Deep Vein Thrombosis (DVT) and/or Pulmonary Embolism (PE)

EINSTEIN DVT and EINSTEIN PE Studies

In the pooled analysis of the EINSTEIN DVT and EINSTEIN PE clinical studies, the most frequent adverse reactions leading to permanent drug discontinuation were bleeding events, with XARELTO vs. enoxaparin/Vitamin K antagonist (VKA) incidence rates of 1.7% vs. 1.5%, respectively. The mean duration of treatment was 208 days for XARELTO-treated patients and 204 days for enoxaparin/VKA-treated patients.

Table 3 shows the number of patients experiencing major bleeding events in the pooled analysis of the EINSTEIN DVT and EINSTEIN PE studies.

Table 3: Bleeding Events* in the Pooled Analysis of EINSTEIN DVT and EINSTEIN PE Studies

Parameter	XARELTO [†] N=4130 n (%)	Enoxaparin/ VKA [†] N=4116 n (%)
Major bleeding event	40 (1.0)	72 (1.7)
Fatal bleeding	3 (<0.1)	8 (0.2)
Intracranial	2 (<0.1)	4 (<0.1)
Non-fatal critical organ bleeding	10 (0.2)	29 (0.7)
Intracranial [‡]	3 (<0.1)	10 (0.2)
Retroperitoneal [‡]	1 (<0.1)	8 (0.2)
Intraocular [‡]	3 (<0.1)	2 (<0.1)
Intra-articular [‡]	0	4 (<0.1)
Non-fatal non-critical organ bleeding [§]	27 (0.7)	37 (0.9)
Decrease in Hb \geq 2 g/dL	28 (0.7)	42 (1.0)
Transfusion of \geq 2 units of whole blood or packed red blood cells	18 (0.4)	25 (0.6)
Clinically relevant non-major bleeding	357 (8.6)	357 (8.7)
Any bleeding	1169 (28.3)	1153 (28.0)

* Bleeding event occurred after randomization and up to 2 days after the last dose of study drug. Although a patient may have had 2 or more events, the patient is counted only once in a category.

[†] Treatment schedule in EINSTEIN DVT and EINSTEIN PE studies: XARELTO 15 mg twice daily for 3 weeks followed by 20 mg once daily; enoxaparin/VKA [enoxaparin: 1 mg/kg twice daily, VKA: individually titrated doses to achieve a target INR of 2.5 (range: 2.0-3.0)]

[‡] Treatment-emergent major bleeding events with at least >2 subjects in any pooled treatment group

[§] Major bleeding which is not fatal or in a critical organ, but resulting in a decrease in Hb \geq 2 g/dL and/or transfusion of \geq 2 units of whole blood or packed red blood cells

Reduction in the Risk of Recurrence of DVT and/or PE

EINSTEIN CHOICE Study

In the EINSTEIN CHOICE clinical study, the most frequent adverse reactions associated with permanent drug discontinuation were bleeding events, with incidence rates of 1% for XARELTO 10 mg, 2% for XARELTO 20 mg, and 1% for acetylsalicylic acid (aspirin) 100 mg. The mean duration of treatment was 293 days for XARELTO 10 mg-treated patients and 286 days for aspirin 100 mg-treated patients.

Table 4 shows the number of patients experiencing bleeding events in the EINSTEIN CHOICE study.

Table 4: Bleeding Events* in EINSTEIN CHOICE

Parameter	XARELTO[†] 10 mg N=1127 n (%)	Acetylsalicylic Acid (aspirin)[†] 100 mg N=1131 n (%)
Major bleeding event	5 (0.4)	3 (0.3)
Fatal bleeding	0	1 (<0.1)
Non-fatal critical organ bleeding	2 (0.2)	1 (<0.1)
Non-fatal non-critical organ bleeding [§]	3 (0.3)	1 (<0.1)
Clinically relevant non-major (CRNM) bleeding [¶]	22 (2.0)	20 (1.8)
Any bleeding	151 (13.4)	138 (12.2)

* Bleeding event occurred after the first dose and up to 2 days after the last dose of study drug. Although a patient may have had 2 or more events, the patient is counted only once in a category.

[†] Treatment schedule: XARELTO 10 mg once daily or aspirin 100 mg once daily.

[§] Major bleeding which is not fatal or in a critical organ, but resulting in a decrease in Hb \geq 2 g/dL and/or transfusion of \geq 2 units of whole blood or packed red blood cells.

[¶] Bleeding which was clinically overt, did not meet the criteria for major bleeding, but was associated with medical intervention, unscheduled contact with a physician, temporary cessation of treatment, discomfort for the patient, or impairment of activities of daily life.

In the EINSTEIN CHOICE study, there was an increased incidence of bleeding, including major and CRNM bleeding in the XARELTO 20 mg group compared to the XARELTO 10 mg or aspirin 100 mg groups.

Prophylaxis of Deep Vein Thrombosis Following Hip or Knee Replacement Surgery

In the RECORD clinical trials, the overall incidence rate of adverse reactions leading to permanent treatment discontinuation was 3.7% with XARELTO.

The rates of major bleeding events and any bleeding events observed in patients in the RECORD clinical trials are shown in Table 5.

Table 5: Bleeding Events* in Patients Undergoing Hip or Knee Replacement Surgeries (RECORD 1-3)

	XARELTO 10 mg	Enoxaparin[†]
Total treated patients	N=4487	N=4524
	n (%)	n (%)
Major bleeding event	14 (0.3)	9 (0.2)
Fatal bleeding	1 (<0.1)	0
Bleeding into a critical organ	2 (<0.1)	3 (0.1)
Bleeding that required re-operation	7 (0.2)	5 (0.1)
Extra-surgical site bleeding requiring transfusion of >2 units of whole blood or packed cells	4 (0.1)	1 (<0.1)
Any bleeding event [‡]	261 (5.8)	251 (5.6)
Hip Surgery Studies	N=3281	N=3298
	n (%)	n (%)
Major bleeding event	7 (0.2)	3 (0.1)
Fatal bleeding	1 (<0.1)	0
Bleeding into a critical organ	1 (<0.1)	1 (<0.1)
Bleeding that required re-operation	2 (0.1)	1 (<0.1)
Extra-surgical site bleeding requiring transfusion of >2 units of whole blood or packed cells	3 (0.1)	1 (<0.1)
Any bleeding event [‡]	201 (6.1)	191 (5.8)
Knee Surgery Study	N=1206	N=1226
	n (%)	n (%)
Major bleeding event	7 (0.6)	6 (0.5)
Fatal bleeding	0	0
Bleeding into a critical organ	1 (0.1)	2 (0.2)
Bleeding that required re-operation	5 (0.4)	4 (0.3)
Extra-surgical site bleeding requiring transfusion of >2 units of whole blood or packed cells	1 (0.1)	0
Any bleeding event [‡]	60 (5.0)	60 (4.9)

* Bleeding events occurring any time following the first dose of double-blind study medication (which may have been prior to administration of active drug) until two days after the last dose of double-blind study medication. Patients may have more than one event.

† Includes the placebo-controlled period for RECORD 2, enoxaparin dosing was 40 mg once daily (RECORD 1-3)

‡ Includes major bleeding events

Following XARELTO treatment, the majority of major bleeding complications ($\geq 60\%$) occurred during the first week after surgery.

Prophylaxis of Venous Thromboembolism in Acutely Ill Medical Patients at Risk for Thromboembolic Complications Not at High Risk of Bleeding

In the MAGELLAN study, the most frequent adverse reactions associated with permanent drug discontinuation were bleeding events. Cases of pulmonary hemorrhage and pulmonary hemorrhage with bronchiectasis were observed. Patients with bronchiectasis/pulmonary cavitation, active cancer (i.e., undergoing acute, in-hospital cancer treatment), dual antiplatelet

therapy or active gastroduodenal ulcer or any bleeding in the previous three months all had an excess of bleeding with XARELTO compared with enoxaparin/placebo and are excluded from all MAGELLAN data presented in Table 6. The incidence of bleeding leading to drug discontinuation was 2.5% for XARELTO vs. 1.4% for enoxaparin/placebo.

Table 6 shows the number of patients experiencing various types of bleeding events in the MAGELLAN study.

Table 6: Bleeding Events in MAGELLAN* Study–Safety Analysis Set - On Treatment Plus 2 Days

MAGELLAN Study [†]	XARELTO 10 mg N=3218 n (%)	Enoxaparin 40 mg /placebo N=3229 n (%)
Major bleeding ^{‡†}	22 (0.7)	15 (0.5)
Critical site bleeding	7 (0.2)	4 (0.1)
Fatal bleeding [§]	3 (<0.1)	1 (<0.1)
Clinically relevant non-major bleeding events (CRNM)	93 (2.9)	34 (1.1)

* Patients at high risk of bleeding (i.e. bronchiectasis/pulmonary cavitation, active cancer, dual antiplatelet therapy or active gastroduodenal ulcer or any bleeding in the previous three months) were excluded.

† Major bleeding events within each subcategory were counted once per patient, but patients may have contributed events to multiple subcategories. These events occurred during treatment or within 2 days of stopping treatment.

‡ Defined as clinically overt bleeding associated with a drop in hemoglobin of ≥ 2 g/dL, a transfusion of ≥ 2 units of packed red blood cells or whole blood, bleeding at a critical site, or with a fatal outcome.

§ Fatal bleeding is adjudicated death with the primary cause of death from bleeding.

¶ Patients received either XARELTO or placebo once daily for 35 \pm 4 days starting in hospital and continuing post hospital discharge or received enoxaparin or placebo once daily for 10 \pm 4 days in the hospital.

Reduction of Risk of Major Cardiovascular Events in Patients with Chronic CAD or PAD

In the COMPASS trial, the most frequent adverse reactions associated with permanent drug discontinuation were bleeding events, with incidence rates of 2.7% for XARELTO 2.5 mg twice daily in combination with aspirin 100 mg once daily vs. 1.2% for aspirin 100 mg once daily.

Table 7 shows the number of patients experiencing various types of major bleeding events in the COMPASS trial.

Table 7: Major Bleeding Events* in COMPASS - On Treatment Plus 2 days

Parameter	XARELTO plus aspirin[†] N=9134 n (%/year)	Aspirin alone[†] N=9107 n (%/year)	XARELTO plus aspirin vs. Aspirin alone HR (95 % CI)
Modified ISTH Major Bleeding [‡]	263 (1.6)	144 (0.9)	1.84 (1.50, 2.26)
- Fatal bleeding event	12 (<0.1)	8 (<0.1)	1.51 (0.62, 3.69)
Intracranial hemorrhage (ICH)	6 (<0.1)	3 (<0.1)	2.01 (0.50, 8.03)
Non-intracranial	6 (<0.1)	5 (<0.1)	1.21 (0.37, 3.96)
- Symptomatic bleeding in critical organ (non-fatal)	58 (0.3)	43 (0.3)	1.36 (0.91, 2.01)
ICH	23 (0.1)	21 (0.1)	1.09 (0.61, 1.98)
Hemorrhagic Stroke	18 (0.1)	13 (<0.1)	1.38 (0.68, 2.82)
Other ICH	6 (<0.1)	9 (<0.1)	0.67 (0.24, 1.88)
- Bleeding into the surgical site requiring reoperation (non-fatal, not in critical organ)	7 (<0.1)	6 (<0.1)	1.17 (0.39, 3.48)
- Bleeding leading to hospitalization (non-fatal, not in critical organ, not requiring reoperation)	188 (1.1)	91 (0.5)	2.08 (1.62, 2.67)
Major GI bleeding	117 (0.7)	49 (0.3)	2.40 (1.72, 3.35)

* Major bleeding events within each subcategory were counted once per patient, but patients may have contributed events to multiple subcategories. These events occurred during treatment or within 2 days of stopping treatment.

† Treatment schedule: XARELTO 2.5 mg twice daily plus aspirin 100 mg once daily, or aspirin 100 mg once daily

‡ Defined as i) fatal bleeding, or ii) symptomatic bleeding in a critical area or organ, such as intraarticular, intramuscular with compartment syndrome, intraspinal, intracranial, intraocular, respiratory, pericardial, liver, pancreas, retroperitoneal, adrenal gland or kidney; or iii) bleeding into the surgical site requiring reoperation, or iv) bleeding leading to hospitalization.

CI: confidence interval; HR: hazard ratio; ISTH: International Society on Thrombosis and Hemostasis

Figure 2 shows the risk of modified ISTH major bleeding events across major subgroups.

Figure 2: Risk of Modified ISTH Major Bleeding Events by Baseline Characteristics in COMPASS – On Treatment Plus 2 Days

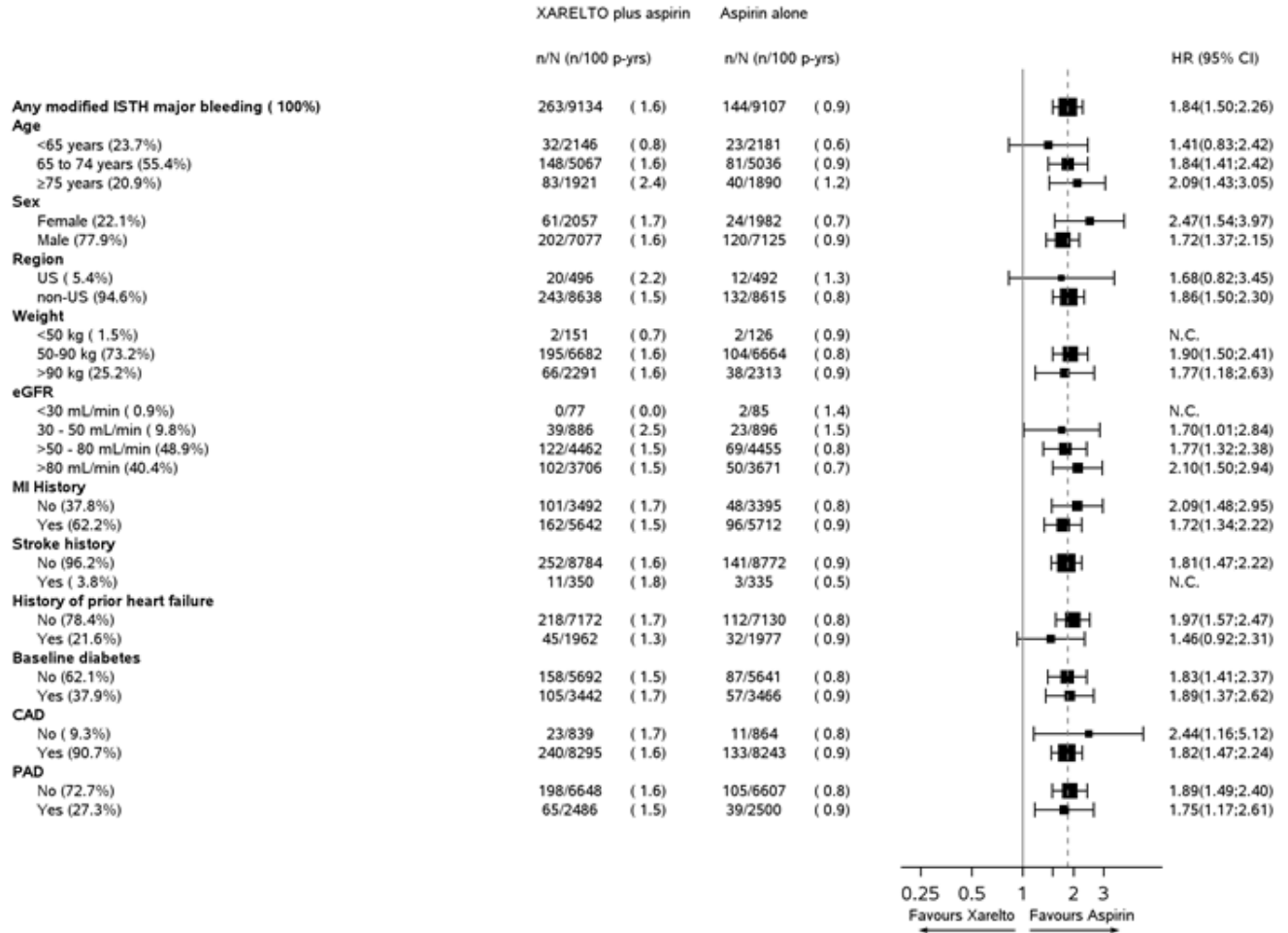

Other Adverse Reactions

Non-hemorrhagic adverse reactions reported in $\geq 1\%$ of XARELTO-treated patients in the EINSTEIN DVT and EINSTEIN PE studies are shown in Table 8.

Table 8: Other Adverse Reactions* Reported by $\geq 1\%$ of XARELTO-Treated Patients in EINSTEIN DVT and EINSTEIN PE Studies

Body System Adverse Reaction		
EINSTEIN DVT Study	XARELTO 20 mg N=1718 n (%)	Enoxaparin/VKA N=1711 n (%)
Gastrointestinal disorders		
Abdominal pain	46 (2.7)	25 (1.5)
General disorders and administration site conditions		
Fatigue	24 (1.4)	15 (0.9)
Musculoskeletal and connective tissue disorders		
Back pain	50 (2.9)	31 (1.8)
Muscle spasm	23 (1.3)	13 (0.8)
Nervous system disorders		
Dizziness	38 (2.2)	22 (1.3)
Psychiatric disorders		
Anxiety	24 (1.4)	11 (0.6)
Depression	20 (1.2)	10 (0.6)
Insomnia	28 (1.6)	18 (1.1)
EINSTEIN PE Study	XARELTO 20 mg N=2412 n (%)	Enoxaparin/VKA N=2405 n (%)
Skin and subcutaneous tissue disorders		
Pruritus	53 (2.2)	27 (1.1)

* Adverse reaction with Relative Risk >1.5 for XARELTO versus comparator

Non-hemorrhagic adverse reactions reported in $\geq 1\%$ of XARELTO-treated patients in RECORD 1-3 studies are shown in Table 9.

Table 9: Other Adverse Drug Reactions* Reported by $\geq 1\%$ of XARELTO-Treated Patients in RECORD 1-3 Studies

Body System Adverse Reaction	XARELTO 10 mg N=4487 n (%)	Enoxaparin [†] N=4524 n (%)
Injury, poisoning and procedural complications		
Wound secretion	125 (2.8)	89 (2.0)
Musculoskeletal and connective tissue disorders		
Pain in extremity	74 (1.7)	55 (1.2)
Muscle spasm	52 (1.2)	32 (0.7)
Nervous system disorders		
Syncope	55 (1.2)	32 (0.7)
Skin and subcutaneous tissue disorders		
Pruritus	96 (2.1)	79 (1.8)
Blister	63 (1.4)	40 (0.9)

* Adverse reaction occurring any time following the first dose of double-blind medication, which may have been prior to administration of active drug, until two days after the last dose of double-blind study medication

[†] Includes the placebo-controlled period of RECORD 2, enoxaparin dosing was 40 mg once daily (RECORD 1-3)

6.2 Postmarketing Experience

The following adverse reactions have been identified during post-approval use of XARELTO. Because these reactions are reported voluntarily from a population of uncertain size, it is not always possible to reliably estimate their frequency or establish a causal relationship to drug exposure.

Blood and lymphatic system disorders: agranulocytosis, thrombocytopenia

Gastrointestinal disorders: retroperitoneal hemorrhage

Hepatobiliary disorders: jaundice, cholestasis, hepatitis (including hepatocellular injury)

Immune system disorders: hypersensitivity, anaphylactic reaction, anaphylactic shock, angioedema

Nervous system disorders: cerebral hemorrhage, subdural hematoma, epidural hematoma, hemiparesis

Skin and subcutaneous tissue disorders: Stevens-Johnson syndrome, drug reaction with eosinophilia and systemic symptoms (DRESS)

7 DRUG INTERACTIONS

7.1 General Inhibition and Induction Properties

Rivaroxaban is a substrate of CYP3A4/5, CYP2J2, and the P-gp and ATP-binding cassette G2 (ABCG2) transporters. Combined P-gp and strong CYP3A inhibitors increase exposure to rivaroxaban and may increase the risk of bleeding. Combined P-gp and strong CYP3A inducers decrease exposure to rivaroxaban and may increase the risk of thromboembolic events.

7.2 Drugs that Inhibit Cytochrome P450 3A Enzymes and Drug Transport Systems

Interaction with Combined P-gp and Strong CYP3A Inhibitors

Avoid concomitant administration of XARELTO with known combined P-gp and strong CYP3A inhibitors (e.g., ketoconazole and ritonavir) [*see Warnings and Precautions (5.6) and Clinical Pharmacology (12.3)*].

Although clarithromycin is a combined P-gp and strong CYP3A inhibitor, pharmacokinetic data suggests that no precautions are necessary with concomitant administration with XARELTO as the change in exposure is unlikely to affect the bleeding risk [*see Clinical Pharmacology (12.3)*].

Interaction with Combined P-gp and Moderate CYP3A Inhibitors in Patients with Renal Impairment

XARELTO should not be used in patients with CrCl 15 to <80 mL/min who are receiving concomitant combined P-gp and moderate CYP3A inhibitors (e.g., erythromycin) unless the potential benefit justifies the potential risk [*see Warnings and Precautions (5.4) and Clinical Pharmacology (12.3)*].

7.3 Drugs that Induce Cytochrome P450 3A Enzymes and Drug Transport Systems

Avoid concomitant use of XARELTO with drugs that are combined P-gp and strong CYP3A inducers (e.g., carbamazepine, phenytoin, rifampin, St. John's wort) [*see Warnings and Precautions (5.6) and Clinical Pharmacology (12.3)*].

7.4 Anticoagulants and NSAIDs/Aspirin

Coadministration of enoxaparin, warfarin, aspirin, clopidogrel and chronic NSAID use may increase the risk of bleeding [*see Clinical Pharmacology (12.3)*].

Avoid concurrent use of XARELTO with other anticoagulants due to increased bleeding risk unless benefit outweighs risk. Promptly evaluate any signs or symptoms of blood loss if patients

are treated concomitantly with aspirin, other platelet aggregation inhibitors, or NSAIDs [see *Warnings and Precautions (5.2)*].

8 USE IN SPECIFIC POPULATIONS

8.1 Pregnancy

Risk Summary

The limited available data on XARELTO in pregnant women are insufficient to inform a drug-associated risk of adverse developmental outcomes. Use XARELTO with caution in pregnant patients because of the potential for pregnancy related hemorrhage and/or emergent delivery. The anticoagulant effect of XARELTO cannot be reliably monitored with standard laboratory testing. Consider the benefits and risks of XARELTO for the mother and possible risks to the fetus when prescribing XARELTO to a pregnant woman [see *Warnings and Precautions (5.2, 5.7)*].

Adverse outcomes in pregnancy occur regardless of the health of the mother or the use of medications. The estimated background risk of major birth defects and miscarriage for the indicated populations is unknown. In the U.S. general population, the estimated background risk of major birth defects and miscarriage in clinically recognized pregnancies is 2–4% and 15–20%, respectively.

Clinical Considerations

Disease-Associated Maternal and/or Embryo/Fetal Risk

Pregnancy is a risk factor for venous thromboembolism and that risk is increased in women with inherited or acquired thrombophilias. Pregnant women with thromboembolic disease have an increased risk of maternal complications including pre-eclampsia. Maternal thromboembolic disease increases the risk for intrauterine growth restriction, placental abruption and early and late pregnancy loss.

Fetal/Neonatal Adverse Reactions

Based on the pharmacologic activity of Factor Xa inhibitors and the potential to cross the placenta, bleeding may occur at any site in the fetus and/or neonate.

Labor or Delivery

All patients receiving anticoagulants, including pregnant women, are at risk for bleeding and this risk may be increased during labor or delivery [see *Warnings and Precautions (5.7)*]. The risk of bleeding should be balanced with the risk of thrombotic events when considering the use of XARELTO in this setting.

Data

Human Data

There are no adequate or well-controlled studies of XARELTO in pregnant women, and dosing for pregnant women has not been established. Post-marketing experience is currently insufficient to determine a rivaroxaban-associated risk for major birth defects or miscarriage. In an *in vitro* placenta perfusion model, unbound rivaroxaban was rapidly transferred across the human placenta.

Animal Data

Rivaroxaban crosses the placenta in animals. Rivaroxaban increased fetal toxicity (increased resorptions, decreased number of live fetuses, and decreased fetal body weight) when pregnant rabbits were given oral doses of ≥ 10 mg/kg rivaroxaban during the period of organogenesis. This dose corresponds to about 4 times the human exposure of unbound drug, based on AUC comparisons at the highest recommended human dose of 20 mg/day. Fetal body weights decreased when pregnant rats were given oral doses of 120 mg/kg during the period of organogenesis. This dose corresponds to about 14 times the human exposure of unbound drug. In rats, peripartal maternal bleeding and maternal and fetal death occurred at the rivaroxaban dose of 40 mg/kg (about 6 times maximum human exposure of the unbound drug at the human dose of 20 mg/day).

8.2 Lactation

Risk Summary

Rivaroxaban has been detected in human milk. There are insufficient data to determine the effects of rivaroxaban on the breastfed child or on milk production. Rivaroxaban and/or its metabolites were present in the milk of rats. The developmental and health benefits of breastfeeding should be considered along with the mother's clinical need for XARELTO and any potential adverse effects on the breastfed infant from XARELTO or from the underlying maternal condition (*see Data*).

Data

Animal Data

Following a single oral administration of 3 mg/kg of radioactive [^{14}C]-rivaroxaban to lactating rats between Day 8 to 10 postpartum, the concentration of total radioactivity was determined in milk samples collected up to 32 hours post-dose. The estimated amount of radioactivity excreted with milk within 32 hours after administration was 2.1% of the maternal dose.

8.3 Females and Males of Reproductive Potential

Females of reproductive potential requiring anticoagulation should discuss pregnancy planning with their physician.

8.4 Pediatric Use

Safety and effectiveness in pediatric patients have not been established.

8.5 Geriatric Use

Of the total number of patients in the RECORD 1-3 clinical studies evaluating XARELTO, about 54% were 65 years and over, while about 15% were >75 years. In ROCKET AF, approximately 77% were 65 years and over and about 38% were >75 years. In the EINSTEIN DVT, PE and Extension clinical studies approximately 37% were 65 years and over and about 16% were >75 years. In EINSTEIN CHOICE, approximately 39% were 65 years and over and about 12% were >75 years. In the MAGELLAN study, approximately 67% were 65 years and over and about 37% were >75 years. In the COMPASS study, approximately 76% were 65 years and over and about 17% were >75 years. In clinical trials the efficacy of XARELTO in the elderly (65 years or older) was similar to that seen in patients younger than 65 years. Both thrombotic and bleeding event rates were higher in these older patients [*see Clinical Pharmacology (12.3) and Clinical Studies (14)*].

8.6 Renal Impairment

In pharmacokinetic studies, compared to healthy subjects with normal creatinine clearance, rivaroxaban exposure increased by approximately 44 to 64% in subjects with renal impairment. Increases in pharmacodynamic effects were also observed [*see Clinical Pharmacology (12.3)*].

Nonvalvular Atrial Fibrillation

Patients with Chronic Kidney Disease not on Dialysis

In the ROCKET AF trial, patients with CrCl 30 to 50 mL/min were administered XARELTO 15 mg once daily resulting in serum concentrations of rivaroxaban and clinical outcomes similar to those in patients with better renal function administered XARELTO 20 mg once daily. Patients with CrCl <30 mL/min were not studied, but administration of XARELTO 15 mg once daily is expected to result in serum concentrations of rivaroxaban similar to those in patients with moderate renal impairment [*see Clinical Pharmacology (12.3)*].

Patients with End-Stage Renal Disease on Dialysis

Clinical efficacy and safety studies with XARELTO did not enroll patients with end-stage renal disease (ESRD) on dialysis. In patients with ESRD maintained on intermittent hemodialysis, administration of XARELTO 15 mg once daily will result in concentrations of rivaroxaban and pharmacodynamic activity similar to those observed in the ROCKET AF study [*see Clinical Pharmacology (12.2, 12.3)*]. It is not known whether these concentrations will lead to similar stroke reduction and bleeding risk in patients with ESRD on dialysis as was seen in ROCKET AF.

Treatment of DVT and/or PE and Reduction in the Risk of Recurrence of DVT and/or PE

In the EINSTEIN trials, patients with CrCl values <30 mL/min at screening were excluded from the studies, but administration of XARELTO is expected to result in serum concentrations of rivaroxaban similar to those in patients with moderate renal impairment (CrCl 30 to <50 mL/min) [see *Clinical Pharmacology (12.3)*]. Observe closely and promptly evaluate any signs or symptoms of blood loss in patients with CrCl 15 to <30 mL/min. Avoid the use of XARELTO in patients with CrCl <15 mL/min.

Prophylaxis of DVT Following Hip or Knee Replacement Surgery

The combined analysis of the RECORD 1-3 clinical efficacy studies did not show an increase in bleeding risk for patients with CrCl 30 to 50 mL/min and reported a possible increase in total venous thromboemboli in this population. In the RECORD 1-3 trials, patients with CrCl values <30 mL/min at screening were excluded from the studies, but administration of XARELTO 10 mg once daily is expected to result in serum concentrations of rivaroxaban similar to those in patients with moderate renal impairment (CrCl 30 to <50 mL/min) [see *Clinical Pharmacology (12.3)*]. Observe closely and promptly evaluate any signs or symptoms of blood loss in patients with CrCl 15 to <30 mL/min. Avoid the use of XARELTO in patients with CrCl <15 mL/min.

Prophylaxis of Venous Thromboembolism in Acutely Ill Medical Patients at Risk for Thromboembolic Complications Not at High Risk of Bleeding

Patients with CrCl values <30 mL/min at screening were excluded from the MAGELLAN study. In patients with CrCl <30 mL/min a dose of XARELTO 10 mg once daily is expected to result in serum concentrations of rivaroxaban similar to those in patients with moderate renal impairment (CrCl 30 to <50 mL/min) [see *Clinical Pharmacology (12.3)*]. Observe closely and promptly evaluate any signs or symptoms of blood loss in patients with CrCl 15 to <30 mL/min. Avoid use of XARELTO in patients with CrCl <15 mL/min.

Reduction of Risk of Major Cardiovascular Events in Patients with Chronic CAD or PAD Patients with Chronic Kidney Disease not on Dialysis

Patients with a CrCl <15 mL/min at screening were excluded from COMPASS, and limited data are available for patients with a CrCl of 15 to 30 mL/min. In patients with CrCl <30 mL/min, a dose of 2.5 mg XARELTO twice daily is expected to give an exposure similar to that in patients with moderate renal impairment (CrCl 30 to <50 mL/min) [see *Clinical Pharmacology (12.3)*], whose efficacy and safety outcomes were similar to those with preserved renal function.

Patients with End-Stage Renal Disease on Dialysis

No clinical outcome data is available for the use of XARELTO with aspirin in patients with ESRD on dialysis since these patients were not enrolled in COMPASS. In patients with ESRD

maintained on intermittent hemodialysis, administration of XARELTO 2.5 mg twice daily will result in concentrations of rivaroxaban and pharmacodynamic activity similar to those observed in moderate renal impaired patients in the COMPASS study [see *Clinical Pharmacology* (12.2, 12.3)]. It is not known whether these concentrations will lead to similar CV risk reduction and bleeding risk in patients with ESRD on dialysis as was seen in COMPASS.

8.7 Hepatic Impairment

In a pharmacokinetic study, compared to healthy subjects with normal liver function, AUC increases of 127% were observed in subjects with moderate hepatic impairment (Child-Pugh B).

The safety or PK of XARELTO in patients with severe hepatic impairment (Child-Pugh C) has not been evaluated [see *Clinical Pharmacology* (12.3)].

Avoid the use of XARELTO in patients with moderate (Child-Pugh B) and severe (Child-Pugh C) hepatic impairment or with any hepatic disease associated with coagulopathy.

10 OVERDOSAGE

Overdose of XARELTO may lead to hemorrhage. Discontinue XARELTO and initiate appropriate therapy if bleeding complications associated with overdose occur. Rivaroxaban systemic exposure is not further increased at single doses >50 mg due to limited absorption. The use of activated charcoal to reduce absorption in case of XARELTO overdose may be considered. Due to the high plasma protein binding, rivaroxaban is not dialyzable [see *Warnings and Precautions* (5.2) and *Clinical Pharmacology* (12.3)]. Partial reversal of laboratory anticoagulation parameters may be achieved with use of plasma products. An agent to reverse the anti-factor Xa activity of rivaroxaban is available.

11 DESCRIPTION

Rivaroxaban, a factor Xa (FXa) inhibitor, is the active ingredient in XARELTO Tablets with the chemical name 5-Chloro-N-((5S)-2-oxo-3-[4-(3-oxo-4-morpholinyl)phenyl]-1,3-oxazolidin-5-yl)methyl)-2-thiophenecarboxamide. The molecular formula of rivaroxaban is C₁₉H₁₈ClN₃O₅S and the molecular weight is 435.89. The structural formula is:

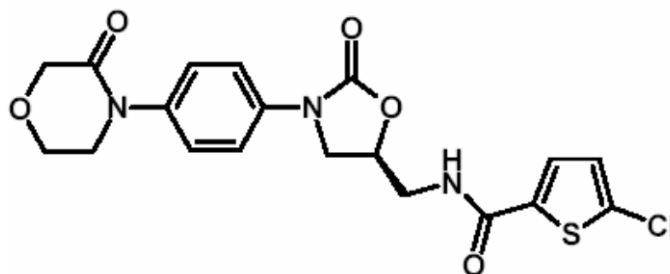

Rivaroxaban is a pure (*S*)-enantiomer. It is an odorless, non-hygroscopic, white to yellowish powder. Rivaroxaban is only slightly soluble in organic solvents (e.g., acetone, polyethylene glycol 400) and is practically insoluble in water and aqueous media.

Each XARELTO tablet contains 2.5 mg, 10 mg, 15 mg, or 20 mg of rivaroxaban. The inactive ingredients of XARELTO are: croscarmellose sodium, hypromellose, lactose monohydrate, magnesium stearate, microcrystalline cellulose, and sodium lauryl sulfate. Additionally, the proprietary film coating mixture used for XARELTO 2.5 mg is Opadry® Light Yellow, containing ferric oxide yellow, hypromellose, polyethylene glycol 3350, and titanium dioxide, and for XARELTO 10 mg tablets is Opadry® Pink and for XARELTO 15 mg tablets is Opadry® Red, both containing ferric oxide red, hypromellose, polyethylene glycol 3350, and titanium dioxide, and for XARELTO 20 mg tablets is Opadry® II Dark Red, containing ferric oxide red, polyethylene glycol 3350, polyvinyl alcohol (partially hydrolyzed), talc, and titanium dioxide.

12 CLINICAL PHARMACOLOGY

12.1 Mechanism of Action

XARELTO is a selective inhibitor of FXa. It does not require a cofactor (such as Anti-thrombin III) for activity. Rivaroxaban inhibits free FXa and prothrombinase activity. Rivaroxaban has no direct effect on platelet aggregation, but indirectly inhibits platelet aggregation induced by thrombin. By inhibiting FXa, rivaroxaban decreases thrombin generation.

12.2 Pharmacodynamics

Dose-dependent inhibition of FXa activity was observed in humans. Neoplastin® prothrombin time (PT), activated partial thromboplastin time (aPTT) and HepTest® are also prolonged dose-dependently. Anti-factor Xa activity is also influenced by rivaroxaban.

Specific Populations

Renal Impairment

The relationship between systemic exposure and pharmacodynamic activity of rivaroxaban was altered in subjects with renal impairment relative to healthy control subjects [*see Use in Specific Populations (8.6)*].

Table 10: Percentage Increase in Rivaroxaban PK and PD Measures in Subjects with Renal Impairment Relative to Healthy Subjects from Clinical Pharmacology Studies

Measure	Parameter	Creatinine Clearance (mL/min)				
		50-79	30-49	15-29	ESRD (on dialysis)*	ESRD (post-dialysis)*
Exposure	AUC	44	52	64	47	56
FXa Inhibition	AUEC	50	86	100	49	33
PT Prolongation	AUEC	33	116	144	112	158

*Separate stand-alone study.

PT = Prothrombin time; FXa = Coagulation factor Xa; AUC = Area under the plasma concentration-time curve; AUEC = Area under the effect-time curve

Hepatic Impairment

Anti-Factor Xa activity was similar in subjects with normal hepatic function and in mild hepatic impairment (Child-Pugh A class). There is no clear understanding of the impact of hepatic impairment beyond this degree on the coagulation cascade and its relationship to efficacy and safety.

12.3 Pharmacokinetics

Absorption

The absolute bioavailability of rivaroxaban is dose-dependent. For the 2.5 mg and 10 mg dose, it is estimated to be 80% to 100% and is not affected by food. XARELTO 2.5 mg and 10 mg tablets can be taken with or without food. For the 20 mg dose in the fasted state, the absolute bioavailability is approximately 66%. Coadministration of XARELTO with food increases the bioavailability of the 20 mg dose (mean AUC and C_{max} increasing by 39% and 76% respectively with food). XARELTO 15 mg and 20 mg tablets should be taken with food [see *Dosage and Administration (2.1)*].

The maximum concentrations (C_{max}) of rivaroxaban appear 2 to 4 hours after tablet intake. The pharmacokinetics of rivaroxaban were not affected by drugs altering gastric pH. Coadministration of XARELTO (30 mg single dose) with the H₂-receptor antagonist ranitidine (150 mg twice daily), the antacid aluminum hydroxide/magnesium hydroxide (10 mL) or XARELTO (20 mg single dose) with the PPI omeprazole (40 mg once daily) did not show an effect on the bioavailability and exposure of rivaroxaban (see Figure 4).

Absorption of rivaroxaban is dependent on the site of drug release in the GI tract. A 29% and 56% decrease in AUC and C_{max} compared to tablet was reported when rivaroxaban granulate is released in the proximal small intestine. Exposure is further reduced when drug is released in the distal small intestine, or ascending colon. Avoid administration of rivaroxaban distal to the stomach which can result in reduced absorption and related drug exposure.

In a study with 44 healthy subjects, both mean AUC and C_{max} values for 20 mg rivaroxaban administered orally as a crushed tablet mixed in applesauce were comparable to that after the whole tablet. However, for the crushed tablet suspended in water and administered via an NG tube followed by a liquid meal, only mean AUC was comparable to that after the whole tablet, and C_{max} was 18% lower.

Distribution

Plasma protein binding of rivaroxaban in human plasma is approximately 92% to 95%, with albumin being the main binding component. The steady-state volume of distribution in healthy subjects is approximately 50 L.

Metabolism

Approximately 51% of an orally administered [^{14}C]-rivaroxaban dose was recovered as inactive metabolites in urine (30%) and feces (21%). Oxidative degradation catalyzed by CYP3A4/5 and CYP2J2 and hydrolysis are the major sites of biotransformation. Unchanged rivaroxaban was the predominant moiety in plasma with no major or active circulating metabolites.

Excretion

In a Phase 1 study, following the administration of [^{14}C]-rivaroxaban, approximately one-third (36%) was recovered as unchanged drug in the urine and 7% was recovered as unchanged drug in feces. Unchanged drug is excreted into urine, mainly via active tubular secretion and to a lesser extent via glomerular filtration (approximate 5:1 ratio). Rivaroxaban is a substrate of the efflux transporter proteins P-gp and ABCG2 (also abbreviated Bcrp). Rivaroxaban's affinity for influx transporter proteins is unknown.

Rivaroxaban is a low-clearance drug, with a systemic clearance of approximately 10 L/hr in healthy volunteers following intravenous administration. The terminal elimination half-life of rivaroxaban is 5 to 9 hours in healthy subjects aged 20 to 45 years.

Specific Populations

The effects of level of renal impairment, age, body weight, and level of hepatic impairment on the pharmacokinetics of rivaroxaban are summarized in Figure 3.

Figure 3: Effect of Specific Populations on the Pharmacokinetics of Rivaroxaban

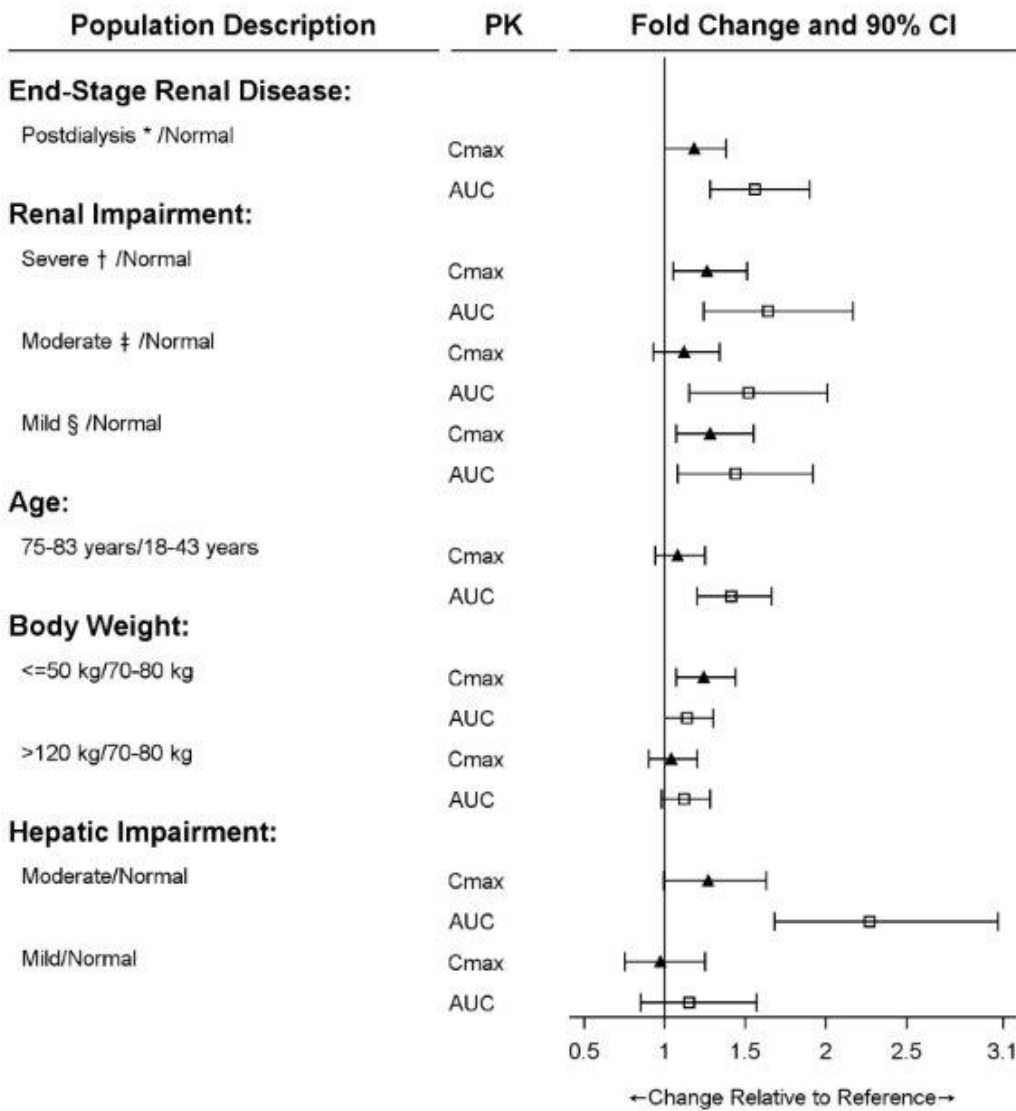

* ESRD subjects maintained with chronic and stable hemodialysis; reported PK findings are following single dose of rivaroxaban post hemodialysis.

† Creatinine clearance 15 to 29 mL/min.

‡ Creatinine clearance 30 to 49 mL/min.

§ Creatinine clearance 50 to 79 mL/min.

[see Dosage and Administration (2.1)].

Gender

Gender did not influence the pharmacokinetics or pharmacodynamics of XARELTO.

Race

Healthy Japanese subjects were found to have 20 to 40% on average higher exposures compared to other ethnicities including Chinese. However, these differences in exposure are reduced when values are corrected for body weight.

Elderly

The terminal elimination half-life is 11 to 13 hours in the elderly subjects aged 60 to 76 years [*see Use in Specific Populations (8.5)*].

Renal Impairment

The safety and pharmacokinetics of single-dose XARELTO (10 mg) were evaluated in a study in healthy subjects [$\text{CrCl} \geq 80 \text{ mL/min}$ ($n=8$)] and in subjects with varying degrees of renal impairment (see Figure 3). Compared to healthy subjects with normal creatinine clearance, rivaroxaban exposure increased in subjects with renal impairment. Increases in pharmacodynamic effects were also observed [*see Use in Specific Populations (8.6)*].

Hemodialysis in ESRD subjects: Systemic exposure to rivaroxaban administered as a single 15 mg dose in ESRD subjects dosed 3 hours after the completion of a 4-hour hemodialysis session (post-dialysis) is 56% higher when compared to subjects with normal renal function (see Table 10). The systemic exposure to rivaroxaban administered 2 hours prior to a 4-hour hemodialysis session with a dialysate flow rate of 600 mL/min and a blood flow rate in the range of 320 to 400 mL/min is 47% higher compared to those with normal renal function. The extent of the increase is similar to the increase in patients with CrCl 15 to 50 mL/min taking XARELTO 15 mg. Hemodialysis had no significant impact on rivaroxaban exposure. Protein binding was similar (86% to 89%) in healthy controls and ESRD subjects in this study.

Hepatic Impairment

The safety and pharmacokinetics of single-dose XARELTO (10 mg) were evaluated in a study in healthy subjects ($n=16$) and subjects with varying degrees of hepatic impairment (see Figure 3). No patients with severe hepatic impairment (Child-Pugh C) were studied. Compared to healthy subjects with normal liver function, significant increases in rivaroxaban exposure were observed in subjects with moderate hepatic impairment (Child-Pugh B) (see Figure 3). Increases in pharmacodynamic effects were also observed [*see Use in Specific Populations (8.7)*].

Drug Interactions

In vitro studies indicate that rivaroxaban neither inhibits the major cytochrome P450 enzymes CYP1A2, 2C8, 2C9, 2C19, 2D6, 2J2, and 3A nor induces CYP1A2, 2B6, 2C19, or 3A. *In vitro* data also indicates a low rivaroxaban inhibitory potential for P-gp and ABCG2 transporters.

The effects of coadministered drugs on the pharmacokinetics of rivaroxaban exposure are summarized in Figure 4 [see *Drug Interactions (7)*].

Figure 4: Effect of Coadministered Drugs on the Pharmacokinetics of Rivaroxaban

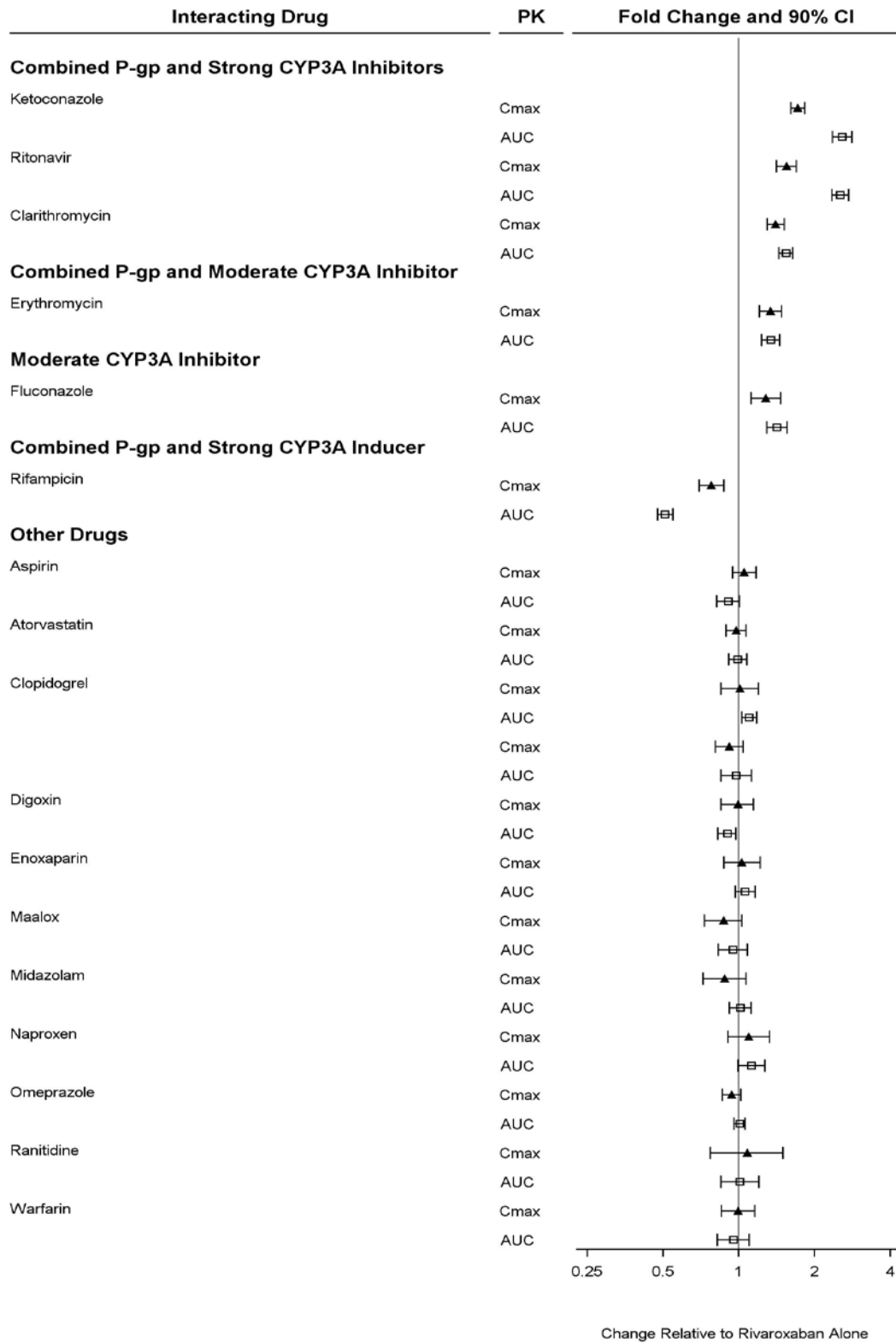

Anticoagulants

In a drug interaction study, single doses of enoxaparin (40 mg subcutaneous) and XARELTO (10 mg) given concomitantly resulted in an additive effect on anti-factor Xa activity. In another study, single doses of warfarin (15 mg) and XARELTO (5 mg) resulted in an additive effect on factor Xa inhibition and PT. Neither enoxaparin nor warfarin affected the pharmacokinetics of rivaroxaban (see Figure 4).

NSAIDs/Aspirin

In ROCKET AF, concomitant aspirin use (almost exclusively at a dose of 100 mg or less) during the double-blind phase was identified as an independent risk factor for major bleeding. NSAIDs are known to increase bleeding, and bleeding risk may be increased when NSAIDs are used concomitantly with XARELTO. Neither naproxen nor aspirin affected the pharmacokinetics of rivaroxaban (see Figure 4).

Clopidogrel

In two drug interaction studies where clopidogrel (300 mg loading dose followed by 75 mg daily maintenance dose) and XARELTO (15 mg single dose) were coadministered in healthy subjects, an increase in bleeding time to 45 minutes was observed in approximately 45% and 30% of subjects in these studies, respectively. The change in bleeding time was approximately twice the maximum increase seen with either drug alone. There was no change in the pharmacokinetics of either drug.

Drug-Disease Interactions with Drugs that Inhibit Cytochrome P450 3A Enzymes and Drug Transport Systems

In a pharmacokinetic trial, XARELTO was administered as a single dose in subjects with mild ($\text{CrCl} = 50$ to 79 mL/min) or moderate renal impairment ($\text{CrCl} = 30$ to 49 mL/min) receiving multiple doses of erythromycin (a combined P-gp and moderate CYP3A inhibitor). Compared to XARELTO administered alone in subjects with normal renal function ($\text{CrCl} > 80$ mL/min), subjects with mild and moderate renal impairment concomitantly receiving erythromycin reported a 76% and 99% increase in AUC_{inf} and a 56% and 64% increase in C_{max} , respectively. Similar trends in pharmacodynamic effects were also observed.

12.6 QT/QTc Prolongation

In a thorough QT study in healthy men and women aged 50 years and older, no QTc prolonging effects were observed for XARELTO (15 mg and 45 mg, single-dose).

13 NON-CLINICAL TOXICOLOGY

13.1 Carcinogenesis, Mutagenesis, Impairment of Fertility

Rivaroxaban was not carcinogenic when administered by oral gavage to mice or rats for up to 2 years. The systemic exposures (AUCs) of unbound rivaroxaban in male and female mice at the highest dose tested (60 mg/kg/day) were 1- and 2-times, respectively, the human exposure of unbound drug at the human dose of 20 mg/day. Systemic exposures of unbound drug in male and female rats at the highest dose tested (60 mg/kg/day) were 2- and 4-times, respectively, the human exposure.

Rivaroxaban was not mutagenic in bacteria (Ames-Test) or clastogenic in V79 Chinese hamster lung cells *in vitro* or in the mouse micronucleus test *in vivo*.

No impairment of fertility was observed in male or female rats when given up to 200 mg/kg/day of rivaroxaban orally. This dose resulted in exposure levels, based on the unbound AUC, at least 13 times the exposure in humans given 20 mg rivaroxaban daily.

14 CLINICAL STUDIES

14.1 Stroke Prevention in Nonvalvular Atrial Fibrillation

The evidence for the efficacy and safety of XARELTO was derived from Rivaroxaban Once-daily oral direct factor Xa inhibition Compared with vitamin K antagonist for the prevention of stroke and Embolism Trial in Atrial Fibrillation (ROCKET AF) [NCT00403767], a multi-national, double-blind study comparing XARELTO (at a dose of 20 mg once daily with the evening meal in patients with CrCl >50 mL/min and 15 mg once daily with the evening meal in patients with CrCl 30 to 50 mL/min) to warfarin (titrated to INR 2.0 to 3.0) to reduce the risk of stroke and non-central nervous system (CNS) systemic embolism in patients with nonvalvular atrial fibrillation (AF). Patients had to have one or more of the following additional risk factors for stroke:

- a prior stroke (ischemic or unknown type), transient ischemic attack (TIA) or non-CNS systemic embolism, or
- 2 or more of the following risk factors:
 - age ≥ 75 years,
 - hypertension,
 - heart failure or left ventricular ejection fraction $\leq 35\%$, or
 - diabetes mellitus

ROCKET AF was a non-inferiority study designed to demonstrate that XARELTO preserved more than 50% of warfarin's effect on stroke and non-CNS systemic embolism as established by previous placebo-controlled studies of warfarin in atrial fibrillation.

A total of 14264 patients were randomized and followed on study treatment for a median of 590 days. The mean age was 71 years and the mean CHADS₂ score was 3.5. The population was 60% male, 83% Caucasian, 13% Asian and 1.3% Black. There was a history of stroke, TIA, or non-CNS systemic embolism in 55% of patients, and 38% of patients had not taken a vitamin K antagonist (VKA) within 6 weeks at time of screening. Concomitant diseases of patients in this study included hypertension 91%, diabetes 40%, congestive heart failure 63%, and prior myocardial infarction 17%. At baseline, 37% of patients were on aspirin (almost exclusively at a dose of 100 mg or less) and few patients were on clopidogrel. Patients were enrolled in Eastern Europe (39%); North America (19%); Asia, Australia, and New Zealand (15%); Western Europe (15%); and Latin America (13%). Patients randomized to warfarin had a mean percentage of time in the INR target range of 2.0 to 3.0 of 55%, lower during the first few months of the study.

In ROCKET AF, XARELTO was demonstrated non-inferior to warfarin for the primary composite endpoint of time to first occurrence of stroke (any type) or non-CNS systemic embolism [HR (95% CI): 0.88 (0.74, 1.03)], but superiority to warfarin was not demonstrated. There is insufficient experience to determine how XARELTO and warfarin compare when warfarin therapy is well-controlled.

Table 11 displays the overall results for the primary composite endpoint and its components.

Table 11: Primary Composite Endpoint Results in ROCKET AF Study (Intent-to-Treat Population)

Event	XARELTO		Warfarin		XARELTO vs. Warfarin
	N=7081 n (%)	Event Rate (per 100 Pt- yrs)	N=7090 n (%)	Event Rate (per 100 Pt- yrs)	Hazard Ratio (95% CI)
Primary Composite Endpoint*	269 (3.8)	2.1	306 (4.3)	2.4	0.88 (0.74, 1.03)
Stroke	253 (3.6)	2.0	281 (4.0)	2.2	
Hemorrhagic Stroke†	33 (0.5)	0.3	57 (0.8)	0.4	
Ischemic Stroke	206 (2.9)	1.6	208 (2.9)	1.6	
Unknown Stroke Type	19 (0.3)	0.2	18 (0.3)	0.1	
Non-CNS Systemic Embolism	20 (0.3)	0.2	27 (0.4)	0.2	

* The primary endpoint was the time to first occurrence of stroke (any type) or non-CNS systemic embolism. Data are shown for all randomized patients followed to site notification that the study would end.

† Defined as primary hemorrhagic strokes confirmed by adjudication in all randomized patients followed up to site notification

Figure 5 is a plot of the time from randomization to the occurrence of the first primary endpoint event in the two treatment arms.

Figure 5: Time to First Occurrence of Stroke (any type) or Non-CNS Systemic Embolism by Treatment Group (Intent-to-Treat Population)

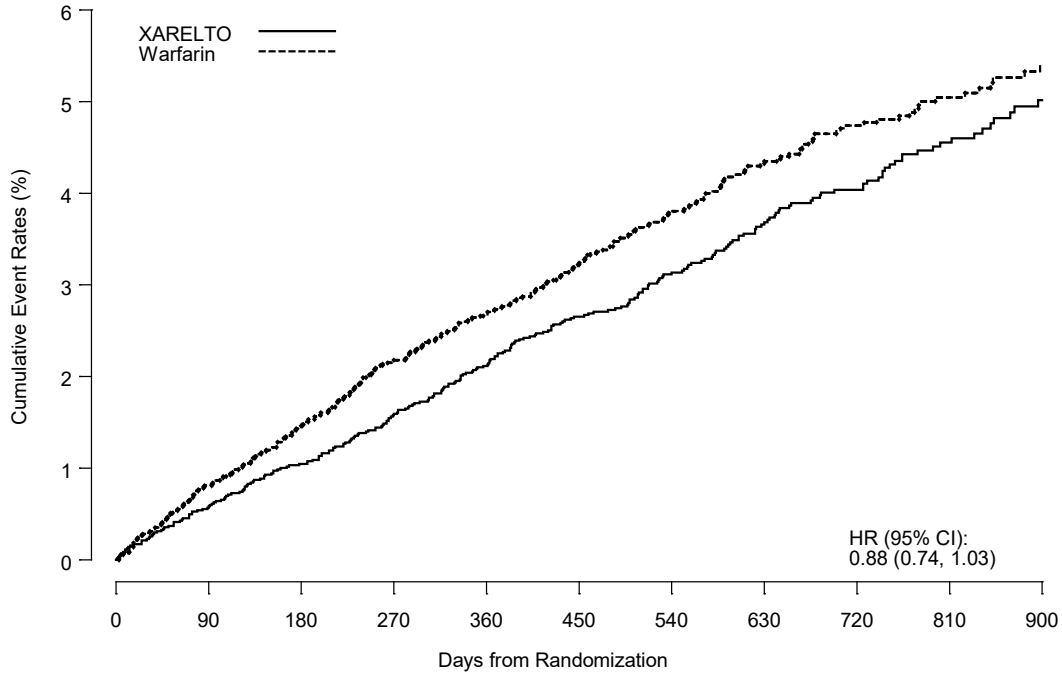

Number of Subjects at Risk:

XARELTO	7081	6927	6774	6620	6470	5580	4779	3820	2951	2058	1321
Warfarin	7090	6910	6755	6590	6440	5561	4756	3807	2944	2069	1319

Figure 6 shows the risk of stroke or non-CNS systemic embolism across major subgroups.

Figure 6: Risk of Stroke or Non-CNS Systemic Embolism by Baseline Characteristics in ROCKET AF* (Intent-to-Treat Population)

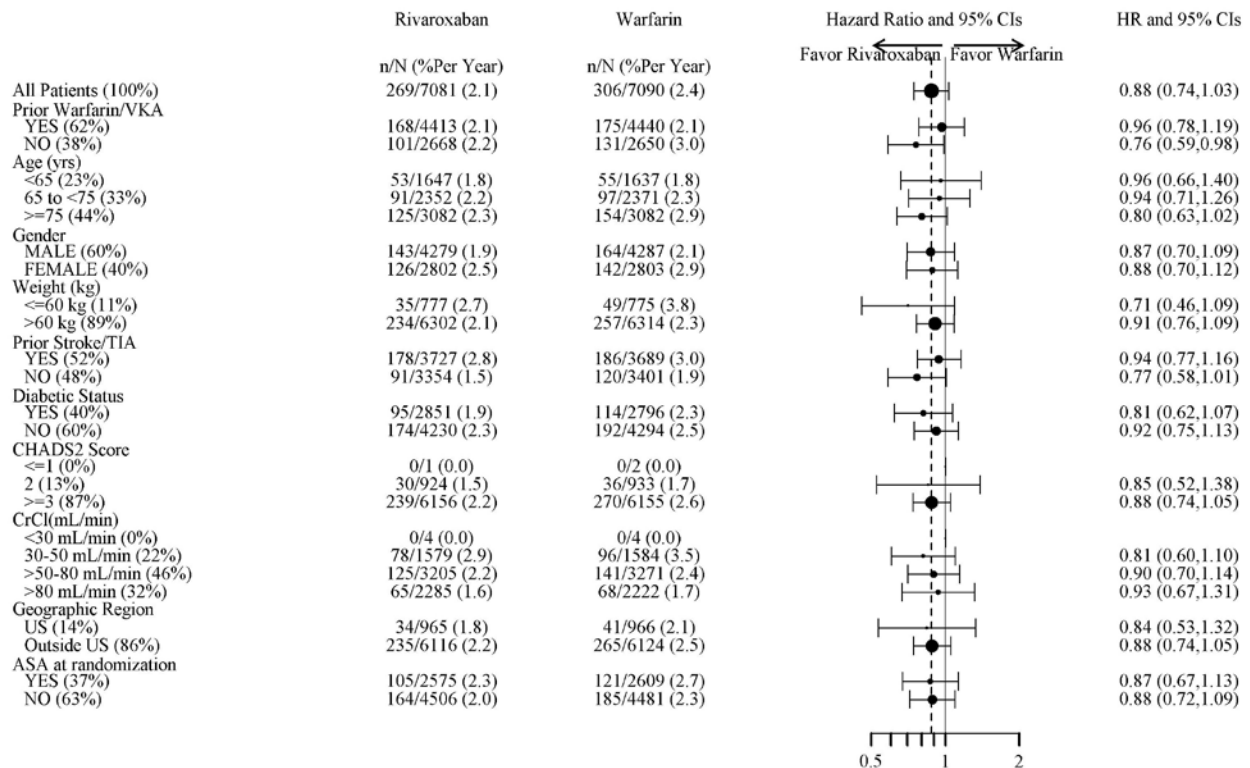

* Data are shown for all randomized patients followed to site notification that the study would end.
 Note: The figure above presents effects in various subgroups all of which are baseline characteristics and all of which were pre-specified (diabetic status was not pre-specified in the subgroup, but was a criterion for the CHADS2 score). The 95% confidence limits that are shown do not take into account how many comparisons were made, nor do they reflect the effect of a particular factor after adjustment for all other factors. Apparent homogeneity or heterogeneity among groups should not be over-interpreted.

The efficacy of XARELTO was generally consistent across major subgroups.

The protocol for ROCKET AF did not stipulate anticoagulation after study drug discontinuation, but warfarin patients who completed the study were generally maintained on warfarin. XARELTO patients were generally switched to warfarin without a period of coadministration of warfarin and XARELTO, so that they were not adequately anticoagulated after stopping XARELTO until attaining a therapeutic INR. During the 28 days following the end of the study, there were 22 strokes in the 4637 patients taking XARELTO vs. 6 in the 4691 patients taking warfarin.

Few patients in ROCKET AF underwent electrical cardioversion for atrial fibrillation. The utility of XARELTO for preventing post-cardioversion stroke and systemic embolism is unknown.

14.2 Treatment of Deep Vein Thrombosis (DVT) and/or Pulmonary Embolism (PE)

EINSTEIN Deep Vein Thrombosis and EINSTEIN Pulmonary Embolism Studies

XARELTO for the treatment of DVT and/or PE was studied in EINSTEIN DVT [NCT00440193] and EINSTEIN PE [NCT00439777], multi-national, open-label, non-inferiority studies comparing XARELTO (at an initial dose of 15 mg twice daily with food for the first three weeks, followed by XARELTO 20 mg once daily with food) to enoxaparin 1 mg/kg twice daily for at least five days with VKA and then continued with VKA only after the target INR (2.0-3.0) was reached. Patients who required thrombectomy, insertion of a caval filter, or use of a fibrinolytic agent and patients with creatinine clearance <30 mL/min, significant liver disease, or active bleeding were excluded from the studies. The intended treatment duration was 3, 6, or 12 months based on investigator's assessment prior to randomization.

A total of 8281 (3449 in EINSTEIN DVT and 4832 in EINSTEIN PE) patients were randomized and followed on study treatment for a mean of 208 days in the XARELTO group and 204 days in the enoxaparin/VKA group. The mean age was approximately 57 years. The population was 55% male, 70% Caucasian, 9% Asian and about 3% Black. About 73% and 92% of XARELTO-treated patients in the EINSTEIN DVT and EINSTEIN PE studies, respectively, received initial parenteral anticoagulant treatment for a median duration of 2 days. Enoxaparin/VKA-treated patients in the EINSTEIN DVT and EINSTEIN PE studies received initial parenteral anticoagulant treatment for a median duration of 8 days. Aspirin was taken as on treatment concomitant antithrombotic medication by approximately 12% of patients in both treatment groups. Patients randomized to VKA had an unadjusted mean percentage of time in the INR target range of 2.0 to 3.0 of 58% in EINSTEIN DVT study and 60% in EINSTEIN PE study, with the lower values occurring during the first month of the study.

In the EINSTEIN DVT and EINSTEIN PE studies, 49% of patients had an idiopathic DVT/PE at baseline. Other risk factors included previous episode of DVT/PE (19%), recent surgery or trauma (18%), immobilization (16%), use of estrogen-containing drug (8%), known thrombophilic conditions (6%), or active cancer (5%).

In the EINSTEIN DVT and EINSTEIN PE studies, XARELTO was demonstrated to be non-inferior to enoxaparin/VKA for the primary composite endpoint of time to first occurrence of recurrent DVT or non-fatal or fatal PE [EINSTEIN DVT HR (95% CI): 0.68 (0.44, 1.04); EINSTEIN PE HR (95% CI): 1.12 (0.75, 1.68)]. In each study the conclusion of non-inferiority was based on the upper limit of the 95% confidence interval for the hazard ratio being less than 2.0.

Table 12 displays the overall results for the primary composite endpoint and its components for EINSTEIN DVT and EINSTEIN PE studies.

Table 12: Primary Composite Endpoint Results* in EINSTEIN DVT and EINSTEIN PE Studies – Intent-to-Treat Population

Event	XARELTO 20 mg [†]	Enoxaparin/VKA [†]	XARELTO vs. Enoxaparin/VKA Hazard Ratio (95% CI)
EINSTEIN DVT Study	N=1731 n (%)	N=1718 n (%)	
Primary Composite Endpoint	36 (2.1)	51 (3.0)	0.68 (0.44, 1.04)
Death (PE)	1 (<0.1)	0	
Death (PE cannot be excluded)	3 (0.2)	6 (0.3)	
Symptomatic PE and DVT	1 (<0.1)	0	
Symptomatic recurrent PE only	20 (1.2)	18 (1.0)	
Symptomatic recurrent DVT only	14 (0.8)	28 (1.6)	
EINSTEIN PE Study	N=2419 n (%)	N=2413 n (%)	
Primary Composite Endpoint	50 (2.1)	44 (1.8)	1.12 (0.75, 1.68)
Death (PE)	3 (0.1)	1 (<0.1)	
Death (PE cannot be excluded)	8 (0.3)	6 (0.2)	
Symptomatic PE and DVT	0	2 (<0.1)	
Symptomatic recurrent PE only	23 (1.0)	20 (0.8)	
Symptomatic recurrent DVT only	18 (0.7)	17 (0.7)	

* For the primary efficacy analysis, all confirmed events were considered from randomization up to the end of intended treatment duration (3, 6 or 12 months) irrespective of the actual treatment duration. If the same patient had several events, the patient may have been counted for several components.

[†] Treatment schedule in EINSTEIN DVT and EINSTEIN PE studies: XARELTO 15 mg twice daily for 3 weeks followed by 20 mg once daily; enoxaparin/VKA [enoxaparin: 1 mg/kg twice daily, VKA: individually titrated doses to achieve a target INR of 2.5 (range: 2.0-3.0)]

Figures 7 and 8 are plots of the time from randomization to the occurrence of the first primary efficacy endpoint event in the two treatment groups in EINSTEIN DVT and EINSTEIN PE studies, respectively.

Figure 7: Time to First Occurrence of the Composite of Recurrent DVT or Non-fatal or Fatal PE by Treatment Group (Intent-to-Treat Population) – EINSTEIN DVT Study

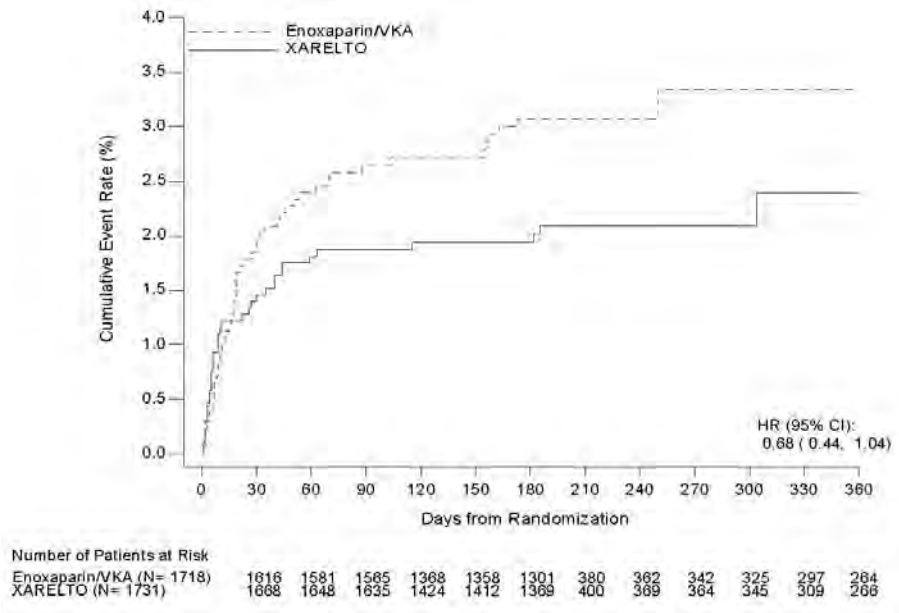
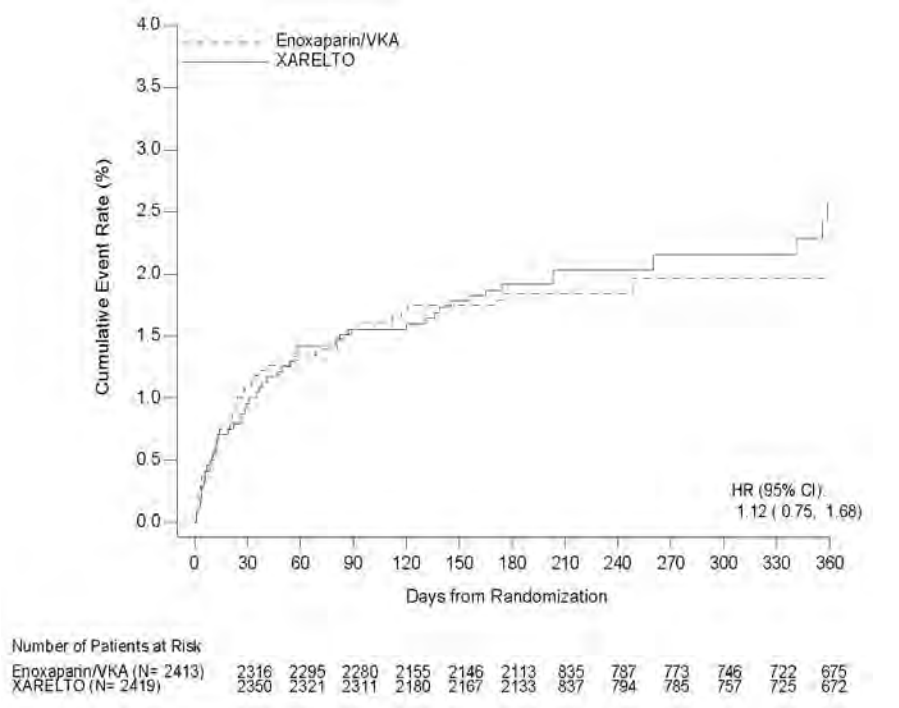

Figure 8: Time to First Occurrence of the Composite of Recurrent DVT or Non-fatal or Fatal PE by Treatment Group (Intent-to-Treat Population) – EINSTEIN PE Study



14.3 Reduction in the Risk of Recurrence of DVT and/or PE

EINSTEIN CHOICE Study

XARELTO for reduction in the risk of recurrence of DVT and of PE was evaluated in the EINSTEIN CHOICE study [NCT02064439], a multi-national, double-blind, superiority study comparing XARELTO (10 or 20 mg once daily with food) to 100 mg acetylsalicylic acid (aspirin) once daily in patients who had completed 6 to 12 months of anticoagulant treatment for DVT and/or PE following the acute event. The intended treatment duration in the study was up to 12 months. Patients with an indication for continued therapeutic-dose anticoagulation were excluded.

Because the benefit-risk assessment favored the 10 mg dose versus aspirin compared to the 20 mg dose versus aspirin, only the data concerning the 10 mg dose is discussed below.

A total of 2275 patients were randomized and followed on study treatment for a mean of 290 days for the XARELTO and aspirin treatment groups. The mean age was approximately 59 years. The population was 56% male, 70% Caucasian, 14% Asian and 3% Black. In the EINSTEIN CHOICE study, 51% of patients had DVT only, 33% had PE only, and 16% had PE and DVT combined. Other risk factors included idiopathic VTE (43%), previous episode of DVT/PE (17%), recent surgery or trauma (12%), prolonged immobilization (10%), use of estrogen containing drugs (5%), known thrombophilic conditions (6%), Factor V Leiden gene mutation (4%), or active cancer (3%).

In the EINSTEIN CHOICE study, XARELTO 10 mg was demonstrated to be superior to aspirin 100 mg for the primary composite endpoint of time to first occurrence of recurrent DVT or non-fatal or fatal PE.

Table 13 displays the overall results for the primary composite endpoint and its components.

Table 13: Primary Composite Endpoint and its Components Results* in EINSTEIN CHOICE Study – Full Analysis Set

Event	XARELTO 10 mg N=1,127 n (%)	Acetylsalicylic Acid (Aspirin) 100 mg N=1,131 n (%)	XARELTO 10 mg vs. Aspirin 100 mg Hazard Ratio (95% CI)
Primary Composite Endpoint	13 (1.2)	50 (4.4)	0.26 (0.14, 0.47) p<0.0001
Symptomatic recurrent DVT	8 (0.7)	29 (2.6)	
Symptomatic recurrent PE	5 (0.4)	19 (1.7)	
Death (PE)	0	1 (<0.1)	
Death (PE cannot be excluded)	0	1 (<0.1)	

* For the primary efficacy analysis, all confirmed events were considered from randomization up to the end of intended treatment duration (12 months) irrespective of the actual treatment duration. The individual component of the primary endpoint represents the first occurrence of the event.

Figure 9 is a plot of the time from randomization to the occurrence of the first primary efficacy endpoint event in the two treatment groups.

Figure 9: Time to First Occurrence of the Composite of Recurrent DVT or Non-fatal or Fatal PE by Treatment Group (Full Analysis Set) – EINSTEIN CHOICE Study

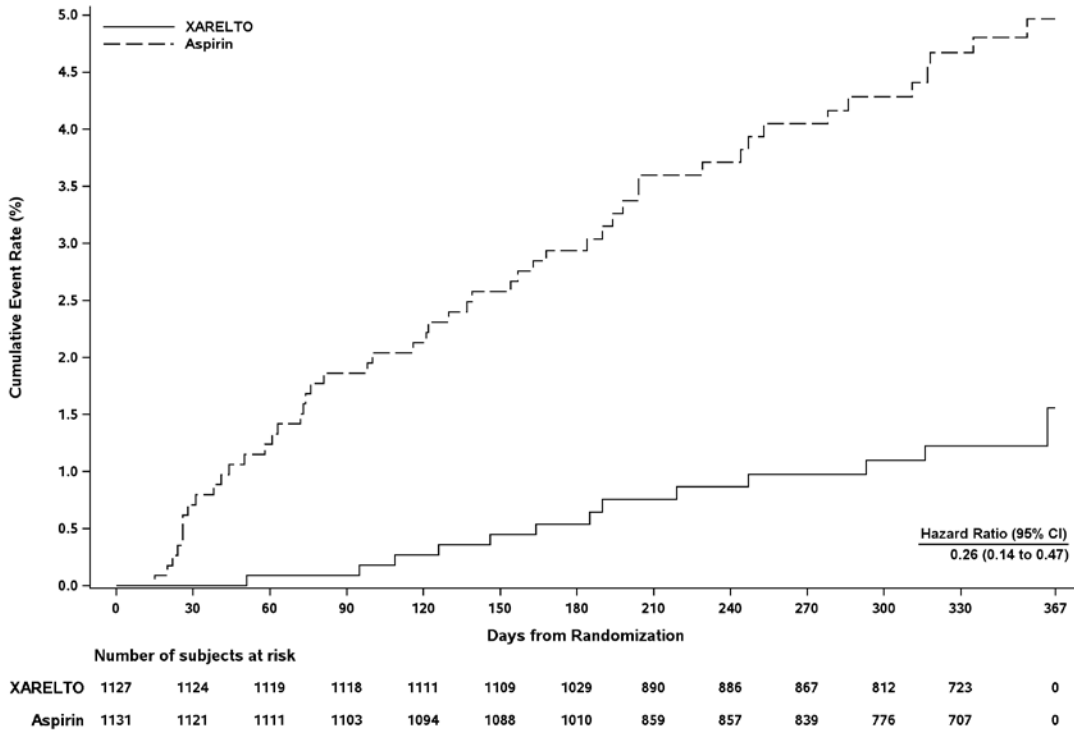

14.4 Prophylaxis of Deep Vein Thrombosis Following Hip or Knee Replacement Surgery

XARELTO was studied in 9011 patients (4487 XARELTO-treated, 4524 enoxaparin-treated patients) in the REgulation of COagulation in ORthopedic Surgery to Prevent DV_T and PE, Controlled, Double-blind, Randomized Study of BAY 59-7939 in the Extended Prevention of VTE in Patients Undergoing Elective Total Hip or Knee Replacement (RECORD 1, 2, and 3) [NCT00329628, NCT00332020, NCT00361894] studies.

The two randomized, double-blind, clinical studies (RECORD 1 and 2) in patients undergoing elective total hip replacement surgery compared XARELTO 10 mg once daily starting at least 6 to 8 hours (about 90% of patients dosed 6 to 10 hours) after wound closure versus enoxaparin 40 mg once daily started 12 hours preoperatively. In RECORD 1 and 2, a total of 6727 patients were randomized and 6579 received study drug. The mean age [\pm standard deviation (SD)] was 63 ± 12.2 (range 18 to 93) years with 49% of patients ≥ 65 years and 55% of patients were female. More than 82% of patients were White, 7% were Asian, and less than 2% were Black. The studies excluded patients undergoing staged bilateral total hip replacement, patients with severe renal impairment defined as an estimated creatinine clearance <30 mL/min, or patients with significant liver disease (hepatitis or cirrhosis). In RECORD 1, the mean exposure duration (\pm SD) to active XARELTO and enoxaparin was 33.3 ± 7.0 and 33.6 ± 8.3 days, respectively. In RECORD 2, the mean exposure duration to active XARELTO and enoxaparin was 33.5 ± 6.9 and 12.4 ± 2.9 days, respectively. After Day 13, oral placebo was continued in the enoxaparin group for the remainder of the double-blind study duration. The efficacy data for RECORD 1 and 2 are provided in Table 14.

Table 14: Summary of Key Efficacy Analysis Results for Patients Undergoing Total Hip Replacement Surgery - Modified Intent-to-Treat Population

Treatment Dosage and Duration	RECORD 1			RECORD 2		
	XARELTO 10 mg once daily	Enoxaparin 40 mg once daily	RRR*, p-value	XARELTO 10 mg once daily	Enoxaparin [†] 40 mg once daily	RRR*, p-value
Number of Patients	N=1513	N=1473		N=834	N=835	
Total VTE	17 (1.1%)	57 (3.9%)	71% (95% CI: 50, 83), p<0.001	17 (2.0%)	70 (8.4%)	76% (95% CI: 59, 86), p<0.001
Components of Total VTE						
Proximal DVT	1 (0.1%)	31 (2.1%)		5 (0.6%)	40 (4.8%)	
Distal DVT	12 (0.8%)	26 (1.8%)		11 (1.3%)	43 (5.2%)	
Non-fatal PE	3 (0.2%)	1 (0.1%)		1 (0.1%)	4 (0.5%)	
Death (any cause)	4 (0.3%)	4 (0.3%)		2 (0.2%)	4 (0.5%)	
Number of Patients	N=1600	N=1587		N=928	N=929	
Major VTE[‡]	3 (0.2%)	33 (2.1%)	91% (95% CI: 71, 97), p<0.001	6 (0.7%)	45 (4.8%)	87% (95% CI: 69, 94), p<0.001
Number of Patients	N=2103	N=2119		N=1178	N=1179	
Symptomatic VTE	5 (0.2%)	11 (0.5%)		3 (0.3%)	15 (1.3%)	

* Relative Risk Reduction; CI = confidence interval

[†] Includes the placebo-controlled period of RECORD 2

[‡] Proximal DVT, nonfatal PE or VTE-related death

One randomized, double-blind, clinical study (RECORD 3) in patients undergoing elective total knee replacement surgery compared XARELTO 10 mg once daily started at least 6 to 8 hours (about 90% of patients dosed 6 to 10 hours) after wound closure versus enoxaparin. In RECORD 3, the enoxaparin regimen was 40 mg once daily started 12 hours preoperatively. The mean age (\pm SD) of patients in the study was 68 ± 9.0 (range 28 to 91) years with 66% of patients ≥ 65 years. Sixty-eight percent (68%) of patients were female. Eighty-one percent (81%) of patients were White, less than 7% were Asian, and less than 2% were Black. The study excluded patients with severe renal impairment defined as an estimated creatinine clearance <30 mL/min or patients with significant liver disease (hepatitis or cirrhosis). The mean exposure duration (\pm SD) to active XARELTO and enoxaparin was 11.9 ± 2.3 and 12.5 ± 3.0 days, respectively. The efficacy data are provided in Table 15.

Table 15: Summary of Key Efficacy Analysis Results for Patients Undergoing Total Knee Replacement Surgery - Modified Intent-to-Treat Population

Treatment Dosage and Duration	RECORD 3		
	XARELTO 10 mg once daily	Enoxaparin 40 mg once daily	RRR*, p-value
Number of Patients	N=813	N=871	
Total VTE	79 (9.7%)	164 (18.8%)	48% (95% CI: 34, 60), p<0.001
Components of events contributing to Total VTE			
Proximal DVT	9 (1.1%)	19 (2.2%)	
Distal DVT	74 (9.1%)	154 (17.7%)	
Non-fatal PE	0	4 (0.5%)	
Death (any cause)	0	2 (0.2%)	
Number of Patients	N=895	N=917	
Major VTE†	9 (1.0%)	23 (2.5%)	60% (95% CI: 14, 81), p = 0.024
Number of Patients	N=1206	N=1226	
Symptomatic VTE	8 (0.7%)	24 (2.0%)	

* Relative Risk Reduction; CI = confidence interval

† Proximal DVT, nonfatal PE or VTE-related death

14.5 Prophylaxis of Venous Thromboembolism in Acutely Ill Medical Patients at Risk for Thromboembolic Complications Not at High Risk of Bleeding

The efficacy and safety of XARELTO for prophylaxis of venous thromboembolism in acutely ill medical patients at risk for thromboembolic complications not at high risk of bleeding was evaluated in the MAGELLAN study (Multicenter, randomized, parallel Group Efficacy and safety study for the prevention of venous thromboembolism in hospitalized medically ill patients comparing rivaroxaban with enoxaparin [NCT00571649]). MAGELLAN was a multicenter, randomized, double-blind, parallel-group efficacy and safety study comparing XARELTO to enoxaparin, in the prevention of VTE in hospitalized acutely ill medical patients during the in-hospital and post-hospital discharge period. Eligible patients included adults who were at least 40 years of age, hospitalized for an acute medical illness, at risk of VTE due to moderate or severe immobility, and had additional risk factors for VTE. The population at risk of VTE was required to have one or more of the following VTE risk factors, i.e. prolonged immobilization, age ≥ 75 years, history of cancer, history of VTE, history of heart failure, thrombophilia, acute infectious disease contributing to the hospitalization and BMI ≥ 35 kg/m²). The causes for hospitalization included heart failure, active cancer, acute ischemic stroke, acute infectious and inflammatory disease and acute respiratory insufficiency. Patients were randomized to receive either XARELTO 10 mg once daily for 35 \pm 4 days starting in hospital and continuing post hospital discharge (n=4050) or enoxaparin 40 mg once daily for 10 \pm 4 days starting in hospital followed by placebo post-discharge (n=4051).

The major efficacy outcome in the MAGELLAN trial was a composite endpoint that included asymptomatic proximal deep venous thrombosis (DVT) in lower extremity, symptomatic

proximal or distal DVT in the lower extremity, symptomatic non-fatal pulmonary embolism (PE), and death related to venous thromboembolism (VTE).

A total of 6024 patients were evaluable for the major efficacy outcome analysis (2967 on XARELTO 10 mg once daily and 3057 on enoxaparin/placebo). The mean age was 68.9 years, with 37.1% of the subject population \geq 75 years. VTE risk factors included severe immobilization at study entry (99.9%), D-dimer $>$ 2X ULN (43.7%), history of heart failure (35.6%), BMI \geq 35 kg/m² (15.2%), chronic venous insufficiency (14.9%), acute infectious disease (13.9%), severe varicosis (12.5%), history of cancer (16.2%), history of VTE (4.5%), hormone replacement therapy (1.1%), and thrombophilia (0.3%), recent major surgery (0.8%) and recent serious trauma (0.2%). The population was 54.7% male, 68.2% White, 20.4% Asian, 1.9% Black and 5.3% Other. Admitting diagnoses for hospitalization were acute infectious diseases (43.8%) followed by congestive heart failure NYHA class III or IV (33.2%), acute respiratory insufficiency (26.4%), acute ischemic stroke (18.5%) and acute inflammatory diseases (3.4%).

Table 16 shows the overall results from the prespecified, modified intent-to-treat (mITT) analysis for the efficacy outcomes and their components. This analysis excludes approximately 25% of the patients mainly due to no ultrasonographic assessment (13.5%), inadequate assessment at day 35 (8.1%), or lack of intake of study medication (1.3%).

Table 16: Efficacy Results at Day 35 (modified Intent-to-Treat) and at Day 10 (per protocol) in the MAGELLAN Study

Events from Day 1 to Day 35, mITT analysis set	XARELTO 10 mg N=2967 n (%)	Enoxaparin 40 mg/ placebo N=3057 n (%)	RR (95% CI)
Primary Composite Endpoint at Day 35	131 (4.4%)	175 (5.7%)	0.77 (0.62, 0.96)
Symptomatic non-fatal PE	10 (0.3)	14 (0.5)	
Symptomatic DVT in lower extremity	13 (0.4)	15 (0.5)	
Asymptomatic proximal DVT in lower extremity	103 (3.5)	133 (4.4)	
VTE related death	19 (0.6)	30 (1.0)	
Events from Day 1 to Day 10, PP analysis set	XARELTO 10 mg N=2938 n (%)	Enoxaparin 40 mg N=2993 n (%)	RR (95% CI)
Primary Composite Endpoint at Day 10	78 (2.7)	82 (2.7)	0.97 (0.71, 1.31)
Symptomatic non-fatal PE	6 (0.2)	2 (<0.1)	
Symptomatic DVT in lower extremity	7 (0.2)	6 (0.2)	
Asymptomatic proximal DVT in lower extremity	71 (2.4)	71 (2.4)	
VTE related death	3 (0.1)	6 (0.2)	
mITT analysis set plus all-cause mortality	N=3096 n (%)	N=3169 n (%)	RR (95% CI)
Other Composite Endpoint at Day 35	266 (8.6)	293 (9.2)	0.93 (0.80, 1.09)
Symptomatic non-fatal PE	10 (0.3)	14 (0.4)	
Symptomatic DVT in lower extremity	13 (0.4)	15 (0.5)	
Asymptomatic proximal DVT in lower extremity	103 (3.3)	133 (4.2)	
All-cause mortality	159 (5.1)	153 (4.8)	

mITT: modified intent-to-treat; PP: per protocol; DVT: Deep vein thrombosis; PE: pulmonary embolism; VTE: venous thromboembolism; CI: Confidence Interval; RR: Relative Risk

Patients with bronchiectasis/pulmonary cavitation, active cancer, dual antiplatelet therapy or active gastroduodenal ulcer or any bleeding in the previous three months (19.4%) all had an excess of bleeding with XARELTO compared with enoxaparin/placebo. Therefore, patients meeting these criteria were excluded from the following analyses presented below.

Table 17 provides the efficacy results for the subgroup of patients not at a high risk of bleeding.

Table 17: Efficacy Results at Day 35 (modified Intent-to-Treat) and at Day 10 (per protocol) in patients not at a high risk of bleeding in the MAGELLAN Study*

Events from Day 1 to Day 35, mITT analysis set	XARELTO 10 mg N=2419 n (%)	Enoxaparin 40 mg/ placebo N=2506 n (%)	RR (95% CI)
Primary Composite Endpoint at Day 35	94 (3.9)	143 (5.7)	0.68 (0.53, 0.88)
Symptomatic non-fatal PE	7 (0.3)	10 (0.4)	
Symptomatic DVT in lower extremity	9 (0.4)	10 (0.4)	
Asymptomatic proximal DVT in lower extremity	73 (3.0)	110 (4.4)	
VTE related death	15 (0.6)	26 (1.0)	
Events from Day 1 to Day 10, PP analysis set	XARELTO 10 mg N=2385 n (%)	Enoxaparin 40 mg N=2433 n (%)	RR (95% CI)
Primary Composite Endpoint at Day 10	58 (2.4)	72 (3.0)	0.82 (0.58, 1.15)
Symptomatic non-fatal PE	5 (0.2)	2 (<0.1)	
Symptomatic DVT in lower extremity	6 (0.3)	4 (0.2)	
Asymptomatic proximal DVT in lower extremity	52 (2.2)	62 (2.5)	
VTE related death	2 (<0.1)	6 (0.2)	
mITT analysis set plus all-cause mortality	N=2504 n (%)	N=2583 n (%)	RR (95% CI)
Other Composite Endpoint at Day 35	184 (7.3)	225 (8.7)	0.84 (0.70, 1.02)
Symptomatic non-fatal PE	7 (0.3)	10 (0.4)	
Symptomatic DVT in lower extremity	9 (0.4)	10 (0.4)	
Asymptomatic proximal DVT in lower extremity	73 (2.9)	110 (4.3)	
All-cause mortality	107 (4.3)	112 (4.3)	

* Patients at high risk of bleeding (i.e. bronchiectasis/pulmonary cavitation, active cancer, dual antiplatelet therapy or active gastroduodenal ulcer or any bleeding in the previous three months) were excluded.

mITT: modified intent-to-treat; PP: per protocol; DVT: Deep vein thrombosis; PE: pulmonary embolism; VTE: venous thromboembolism; CI: Confidence Interval; RR: Relative Risk

14.6 Reduction of Risk of Major Cardiovascular Events in Patients with Chronic CAD or PAD

The evidence for the efficacy and safety of XARELTO for the reduction in the risk of stroke, myocardial infarction, or cardiovascular death in patients with coronary artery disease (CAD) or peripheral artery disease (PAD) was derived from the double-blind Cardiovascular Outcomes for People using Anticoagulation Strategies trial (COMPASS) [NCT10776424]. A total of 27,395 patients were evenly randomized to rivaroxaban 2.5 mg orally twice daily plus aspirin 100 mg once daily, rivaroxaban 5 mg orally twice daily alone, or aspirin 100 mg once daily

alone. Because the 5 mg dose alone was not superior to aspirin alone, only the data concerning the 2.5 mg dose plus aspirin are discussed below.

Patients with established CAD or PAD were eligible. Patients with CAD who were younger than 65 years of age were also required to have documentation of atherosclerosis involving at least two vascular beds or to have at least two additional cardiovascular risk factors (current smoking, diabetes mellitus, an estimated glomerular filtration rate [eGFR] <60 mL per minute, heart failure, or non-lacunar ischemic stroke \geq 1 month earlier). Patients with PAD were either symptomatic with ankle brachial index <0.90 or had asymptomatic carotid artery stenosis \geq 50%, a previous carotid revascularization procedure, or established ischemic disease of one or both lower extremities. Patients were excluded for use of dual antiplatelet, other non-aspirin antiplatelet, or oral anticoagulant therapies, ischemic, non-lacunar stroke within 1 month, hemorrhagic or lacunar stroke at any time, or eGFR <15 mL/min. [see *Warnings and Precautions (5.2)*].

The mean age was 68 years and 21% of the subject population were \geq 75 years. Of the included patients, 91% had CAD, 27% had PAD, and 18% had both CAD and PAD. Of the patients with CAD, 69% had prior MI, 60% had prior percutaneous transluminal coronary angioplasty (PTCA)/atherectomy/ percutaneous coronary intervention (PCI), and 26% had history of coronary artery bypass grafting (CABG) prior to study. Of the patients with PAD, 49% had intermittent claudication, 27% had peripheral artery bypass surgery or peripheral percutaneous transluminal angioplasty, 26% had asymptomatic carotid artery stenosis > 50%, and 4% had limb or foot amputation for arterial vascular disease.

The mean duration of follow-up was 23 months. Relative to aspirin alone, XARELTO plus aspirin reduced the rate of the primary composite outcome of stroke, myocardial infarction or cardiovascular death. The benefit was observed early with a constant treatment effect over the entire treatment period (see Table 18 and Figure 11).

A benefit-risk analysis of the data from COMPASS was performed by comparing the number of CV events (CV deaths, myocardial infarctions and non-hemorrhagic strokes) prevented to the number of fatal or life-threatening bleeding events (fatal bleeds + symptomatic non-fatal bleeds into a critical organ) in the XARELTO plus aspirin group versus the aspirin group. Compared to aspirin alone, during 10,000 patient-years of treatment, XARELTO plus aspirin would be expected to result in 70 fewer CV events and 12 additional life-threatening bleeds, indicating a favorable balance of benefits and risks.

The results in patients with PAD, CAD, and both CAD and PAD were consistent with the overall efficacy and safety results (see Figure 10).

Figure 10 shows the risk of primary efficacy outcome across major subgroups.

Figure 10: Risk of Primary Efficacy Outcome by Baseline Characteristics in COMPASS (Intent-to-Treat Population)

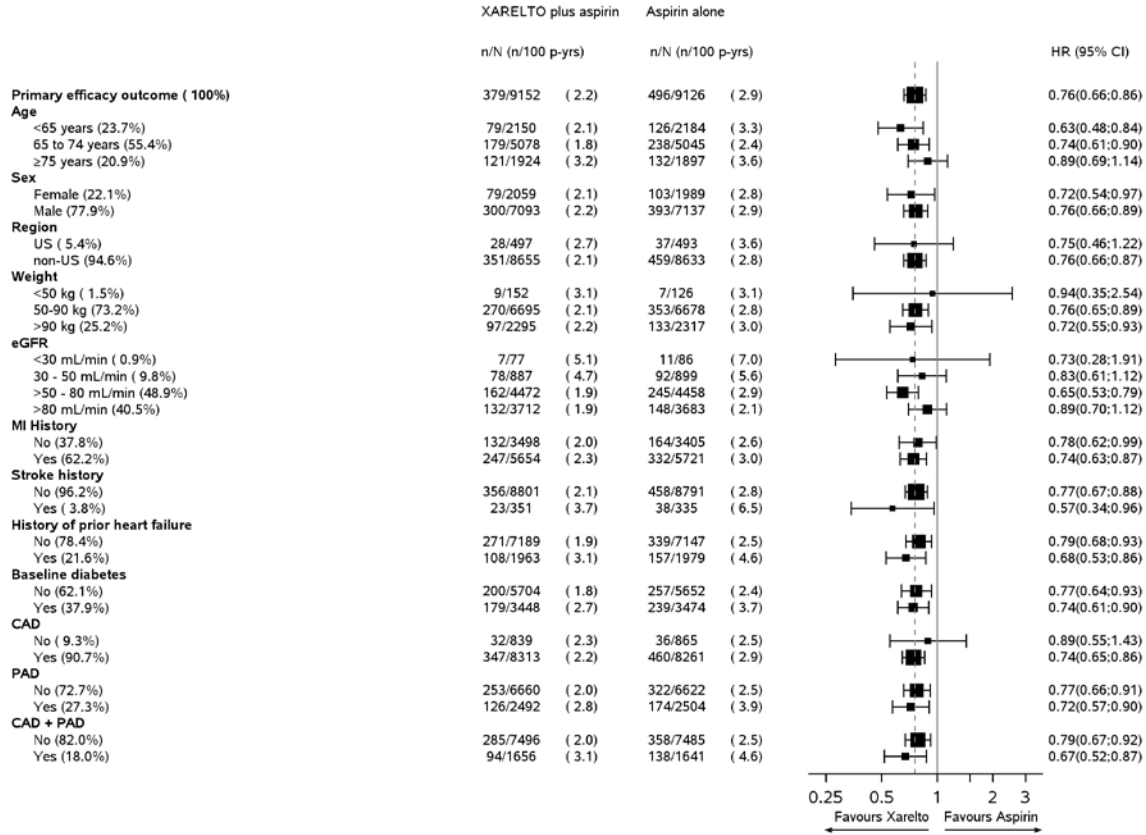

Table 18: Efficacy results from COMPASS study

Study Population	Patients with CAD or PAD*				
	XARELTO plus aspirin [†] N=9152		Aspirin alone [†] N=9126		Hazard Ratio (95% CI) [‡]
	n (%)	Event Rate (%/year)	n (%)	Event Rate (%/year)	
Event					
Stroke, MI or CV death	379 (4.1)	2.2	496 (5.4)	2.9	0.76 (0.66, 0.86)
- Stroke	83 (0.9)	0.5	142 (1.6)	0.8	0.58 (0.44, 0.76)
- MI	178 (1.9)	1.0	205 (2.2)	1.2	0.86 (0.70, 1.05)
- CV death	160 (1.7)	0.9	203 (2.2)	1.2	0.78 (0.64, 0.96)
Coronary heart disease death, MI, ischemic stroke, acute limb ischemia	329 (3.6)	1.9	450 (4.9)	2.6	0.72 (0.63, 0.83)
- Coronary heart disease death [§]	86 (0.9)	0.5	117 (1.3)	0.7	0.73 (0.55, 0.96)
- Ischemic stroke	64 (0.7)	0.4	125 (1.4)	0.7	0.51 (0.38, 0.69)
- Acute limb ischemia [#]	22 (0.2)	0.1	40 (0.4)	0.2	0.55 (0.32, 0.92)
CV death [¶] , MI, ischemic stroke, acute limb ischemia	389 (4.3)	2.2	516 (5.7)	3.00	0.74 (0.65, 0.85)
All-cause mortality	313 (3.4)	1.8	378 (4.1)	2.2	0.82 (0.71, 0.96)
Lower extremity amputations for CV reasons	15 (0.2)	<0.1	31 (0.3)	0.2	0.48 (0.26, 0.89)
Patients with PAD					
Acute limb ischemia	19 (0.8)	0.4	34 (1.4)	0.8	0.56 (0.32, 0.99)

* intention to treat analysis set, primary analyses.

[†] Treatment schedule: XARELTO 2.5 mg twice daily plus aspirin 100 mg once daily, or aspirin 100 mg once daily.

[‡] vs. aspirin 100 mg

[§] Coronary heart disease death: death due to acute MI, sudden cardiac death, or CV procedure.

[¶] CV death includes CHD death, or death due to other CV causes or unknown death.

[#] Acute limb ischemia is defined as limb-threatening ischemia leading to an acute vascular intervention (i.e., pharmacologic, peripheral arterial surgery/reconstruction, peripheral angioplasty/stent, or amputation).

CHD: coronary heart disease, CI: confidence interval; CV: cardiovascular; MI: myocardial infarction

Figure 11: Time to first occurrence of primary efficacy outcome (stroke, myocardial infarction, cardiovascular death) in COMPASS

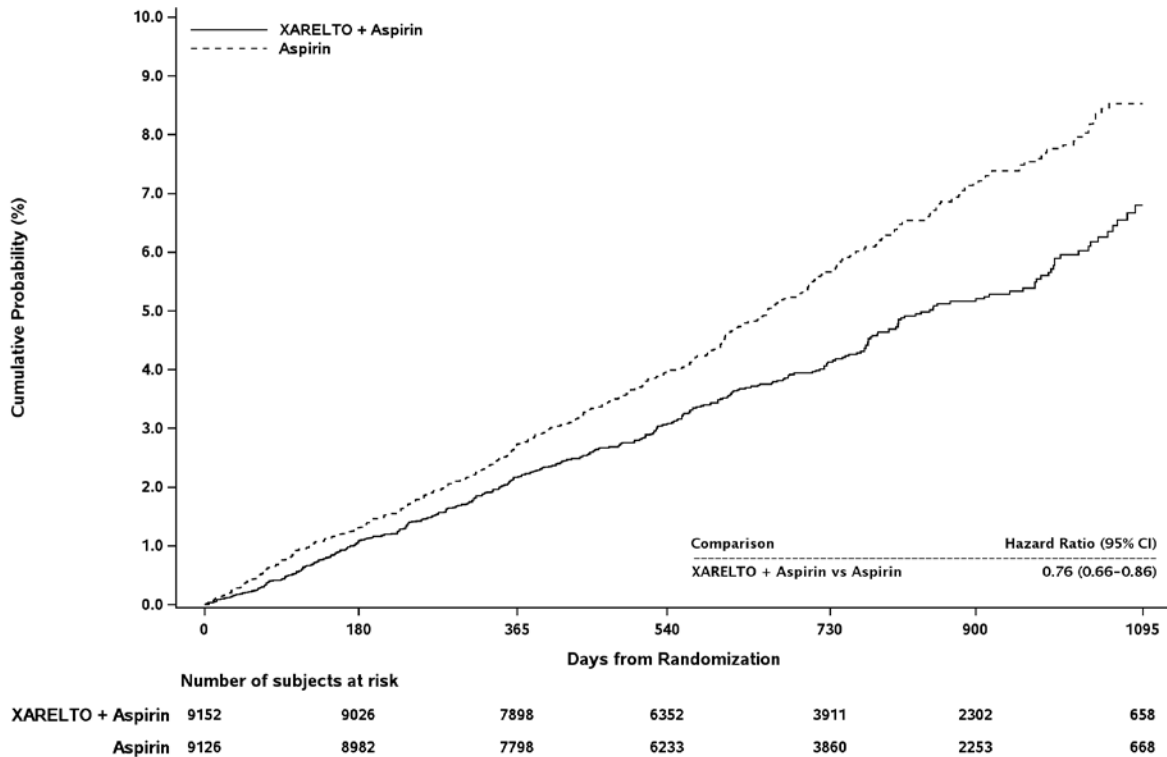

CI: confidence interval

16 HOW SUPPLIED/STORAGE AND HANDLING

XARELTO® (rivaroxaban) Tablets are available in the strengths and packages listed below:

- 2.5 mg tablets are round, light yellow, and film-coated with a triangle pointing down above a “2.5” marked on one side and “Xa” on the other side. The tablets are supplied in the packages listed:

NDC 50458-577-60 Bottle containing 60 tablets

NDC 50458-577-18 Bottle containing 180 tablets

NDC 50458-577-10 Blister package containing 100 tablets (10 blister cards containing 10 tablets each)

- 10 mg tablets are round, light red, biconvex film-coated tablets marked with a triangle pointing down above a “10” on one side, and “Xa” on the other side. The tablets are supplied in the packages listed:

NDC 50458-580-30 Bottle containing 30 tablets
NDC 50458-580-90 Bottle containing 90 tablets
NDC 50458-580-10 Blister package containing 100 tablets (10 blister cards containing 10 tablets each)

- 15 mg tablets are round, red, biconvex film-coated tablets with a triangle pointing down above a “15” marked on one side and “Xa” on the other side. The tablets are supplied in the packages listed:

NDC 50458-578-30 Bottle containing 30 tablets
NDC 50458-578-90 Bottle containing 90 tablets
NDC 50458-578-10 Blister package containing 100 tablets (10 blister cards containing 10 tablets each)

- 20 mg tablets are triangle-shaped, dark red film-coated tablets with a triangle pointing down above a “20” marked on one side and “Xa” on the other side. The tablets are supplied in the packages listed:

NDC 50458-579-30 Bottle containing 30 tablets
NDC 50458-579-90 Bottle containing 90 tablets
NDC 50458-579-89 Bulk bottle containing 1000 tablets
NDC 50458-579-10 Blister package containing 100 tablets (10 blister cards containing 10 tablets each)

- Starter Pack for treatment of deep vein thrombosis and treatment of pulmonary embolism:

NDC 50458-584-51 30-day starter blister pack containing 51 tablets: 42 tablets of 15 mg and 9 tablets of 20 mg

Store at 25°C (77°F) or room temperature; excursions permitted to 15°-30°C (59°-86°F) [see USP Controlled Room Temperature].

Keep out of the reach of children.

17 PATIENT COUNSELING INFORMATION

Advise the patient to read the FDA-approved patient labeling (*Medication Guide*).

Instructions for Patient Use

- Advise patients to take XARELTO only as directed.
- Remind patients to not discontinue XARELTO without first talking to their healthcare professional.
- Advise patients with atrial fibrillation to take XARELTO once daily with the evening meal.
- Advise patients for initial treatment of DVT and/or PE to take XARELTO 15 mg or 20 mg tablets with food at approximately the same time every day [*see Dosage and Administration (2.1)*].
- Advise patients who are at a continued risk of recurrent DVT and/or PE after at least 6 months of initial treatment, to take XARELTO 10 mg once daily with or without food [*see Dosage and Administration (2.1)*].
- Advise patients who cannot swallow the tablet whole to crush XARELTO and combine with a small amount of applesauce followed by food [*see Dosage and Administration (2.5)*].
- For patients requiring an NG tube or gastric feeding tube, instruct the patient or caregiver to crush the XARELTO tablet and mix it with a small amount of water before administering via the tube [*see Dosage and Administration (2.5)*].
- If a dose is missed, advise the patient to take XARELTO as soon as possible on the same day and continue on the following day with their recommended daily dose regimen [*see Dosage and Administration (2.4)*].

Bleeding Risks

- Advise patients to report any unusual bleeding or bruising to their physician. Inform patients that it might take them longer than usual to stop bleeding, and that they may bruise and/or bleed more easily when they are treated with XARELTO [*see Warnings and Precautions (5.2)*].
- If patients have had neuraxial anesthesia or spinal puncture, and particularly, if they are taking concomitant NSAIDs or platelet inhibitors, advise patients to watch for signs and symptoms of spinal or epidural hematoma, such as back pain, tingling, numbness (especially in the lower limbs), muscle weakness, and stool or urine incontinence. If any of these symptoms occur, advise the patient to contact his or her physician immediately [*see Boxed Warning*].

Invasive or Surgical Procedures

Instruct patients to inform their healthcare professional that they are taking XARELTO before any invasive procedure (including dental procedures) is scheduled.

Concomitant Medication and Herbals

Advise patients to inform their physicians and dentists if they are taking, or plan to take, any prescription or over-the-counter drugs or herbals, so their healthcare professionals can evaluate potential interactions [see *Drug Interactions (7)*].

Pregnancy and Pregnancy-Related Hemorrhage

- Advise patients to inform their physician immediately if they become pregnant or intend to become pregnant during treatment with XARELTO [see *Use in Specific Populations (8.1)*].
- Advise pregnant women receiving XARELTO to immediately report to their physician any bleeding or symptoms of blood loss [see *Warnings and Precautions (5.7)*].

Lactation

Advise patients to discuss with their physician the benefits and risks of XARELTO for the mother and for the child if they are nursing or intend to nurse during anticoagulant treatment [see *Use in Specific Populations (8.2)*].

Females and Males of Reproductive Potential

Advise patients who can become pregnant to discuss pregnancy planning with their physician [see *Use in Specific Populations (8.3)*].

Product of Germany

Finished Product Manufactured by:

Janssen Ortho LLC
Gurabo, PR 00778

or

Bayer AG
51368 Leverkusen, Germany

Manufactured for:

Janssen Pharmaceuticals, Inc.
Titusville, NJ 08560

Licensed from:
Bayer HealthCare AG
51368 Leverkusen, Germany

© 2011-2019 Janssen Pharmaceutical Companies

MEDICATION GUIDE
XARELTO® (zah-REL-toe)
(rivaroxaban)
tablets

What is the most important information I should know about XARELTO?

XARELTO may cause serious side effects, including:

- **Increased risk of blood clots if you stop taking XARELTO.** People with atrial fibrillation (a type of irregular heart beat) that is not caused by a heart valve problem (non-valvular) are at an increased risk of forming a blood clot in the heart, which can travel to the brain, causing a stroke, or to other parts of the body. XARELTO lowers your chance of having a stroke by helping to prevent clots from forming. If you stop taking XARELTO, you may have increased risk of forming a clot in your blood.

Do not stop taking XARELTO without talking to the doctor who prescribes it for you. Stopping XARELTO increases your risk of having a stroke. If you have to stop taking XARELTO, your doctor may prescribe another blood thinner medicine to prevent a blood clot from forming.

- **Increased risk of bleeding.** XARELTO can cause bleeding which can be serious and may lead to death. This is because XARELTO is a blood thinner medicine (anticoagulant) that lowers blood clotting. During treatment with XARELTO you are likely to bruise more easily, and it may take longer for bleeding to stop. You may have a higher risk of bleeding if you take XARELTO and have certain other medical problems.

You may have a higher risk of bleeding if you take XARELTO and take other medicines that increase your risk of bleeding, including:

- aspirin or aspirin containing products
- long-term (chronic) use of non-steroidal anti-inflammatory drugs (NSAIDs)
- warfarin sodium (Coumadin®, Jantoven®)
- any medicine that contains heparin
- clopidogrel (Plavix®)
- selective serotonin reuptake inhibitors (SSRIs) or serotonin norepinephrine reuptake inhibitors (SNRIs)
- other medicines to prevent or treat blood clots

Tell your doctor if you take any of these medicines. Ask your doctor or pharmacist if you are not sure if your medicine is one listed above.

Call your doctor or get medical help right away if you develop any of these signs or symptoms of bleeding:

- unexpected bleeding or bleeding that lasts a long time, such as:
 - nose bleeds that happen often
 - unusual bleeding from the gums
 - menstrual bleeding that is heavier than normal or vaginal bleeding
- bleeding that is severe or you cannot control
- red, pink or brown urine
- bright red or black stools (looks like tar)
- cough up blood or blood clots
- vomit blood or your vomit looks like “coffee grounds”
- headaches, feeling dizzy or weak
- pain, swelling, or new drainage at wound sites
- **Spinal or epidural blood clots (hematoma).** People who take a blood thinner medicine (anticoagulant) like XARELTO, and have medicine injected into their spinal and epidural area, or have a spinal puncture have a risk of forming a blood clot that can cause long-term or permanent loss of the ability to move (paralysis). Your risk of developing a spinal or epidural blood clot is higher if:
 - a thin tube called an epidural catheter is placed in your back to give you certain medicine
 - you take NSAIDs or a medicine to prevent blood from clotting
 - you have a history of difficult or repeated epidural or spinal punctures
 - you have a history of problems with your spine or have had surgery on your spine

If you take XARELTO and receive spinal anesthesia or have a spinal puncture, your doctor should watch you closely for symptoms of spinal or epidural blood clots. Tell your doctor right away if you have back pain, tingling, numbness, muscle weakness (especially in your legs and feet), loss of control of the bowels or bladder (incontinence).

XARELTO is not for use in people with artificial heart valves.

XARELTO is not for use in people with antiphospholipid syndrome (APS), especially with positive triple antibody testing.

What is XARELTO?

XARELTO is a prescription medicine used to:

- reduce the risk of stroke and blood clots in people who have a medical condition called atrial fibrillation that is not caused by a heart valve problem. With atrial fibrillation, part of the heart does not beat the way it should. This can lead to the formation of blood clots, which can travel to the brain, causing a stroke, or to other parts of the body.
- treat blood clots in the veins of your legs (deep vein thrombosis or DVT) or lungs (pulmonary embolism or PE)
- reduce the risk of blood clots happening again in people who continue to be at risk for DVT or PE after receiving treatment for blood clots for at least 6 months.
- help prevent a blood clot in the legs and lungs of people who have just had hip or knee replacement surgery.
- help prevent blood clots in certain people hospitalized for an acute illness and after discharge who are at risk of getting blood clots because of the loss of or decreased ability to move around (mobility) and other risks for getting blood clots and who do not have a high risk of bleeding.

XARELTO is used with low dose aspirin to:

- reduce the risk of serious heart problems, heart attack and stroke in people with coronary artery disease (a condition where the blood supply to the heart is reduced or blocked) or peripheral artery disease (a condition where the blood flow to the legs is reduced).

It is not known if XARELTO is safe and effective in children.

Do not take XARELTO if you:

- currently have certain types of abnormal bleeding. Talk to your doctor before taking XARELTO if you currently have unusual bleeding.
- are allergic to rivaroxaban or any of the ingredients in XARELTO. See the end of this Medication Guide for a complete list of ingredients in XARELTO.

Before taking XARELTO, tell your doctor about all of your medical conditions, including if you:

- have or ever had bleeding problems
- have liver or kidney problems
- have antiphospholipid syndrome (APS)
- are pregnant or plan to become pregnant. It is not known if XARELTO will harm your unborn baby.
 - Tell your doctor right away if you become pregnant during treatment with XARELTO. Taking XARELTO while you are pregnant may increase the risk of bleeding in you or in your unborn baby.
 - If you take XARELTO during pregnancy tell your doctor right away if you have any signs or symptoms of bleeding or blood loss. See **“What is the most important information I should know about XARELTO?” for signs and symptoms of bleeding.**
- are breastfeeding or plan to breastfeed. XARELTO can pass into your breast milk. Talk to your doctor about the best way to feed your baby during treatment with XARELTO.

Tell all of your doctors and dentists that you are taking XARELTO. They should talk to the doctor who prescribed XARELTO for you before you have any surgery, medical or dental procedure.

Tell your doctor about all the medicines you take, including prescription and over-the-counter medicines, vitamins, and herbal supplements.

Some of your other medicines may affect the way XARELTO works, causing side effects. Certain medicines may increase your risk of bleeding. See **“What is the most important information I should know about XARELTO?”**

Especially tell your doctor if you take:

- | | |
|-------------------|-----------------|
| • ketoconazole | • ritonavir |
| • erythromycin | • carbamazepine |
| • phenytoin | • rifampin |
| • St. John's wort | |

How should I take XARELTO?

- Take XARELTO exactly as prescribed by your doctor.
- **Do not change your dose or stop taking XARELTO unless your doctor tells you to.** Your doctor may change your dose if needed.
- Your doctor will decide how long you should take XARELTO.
- XARELTO may need to be stopped for one or more days before any surgery or medical or dental procedure. Your doctor will tell you when to stop taking XARELTO and when to start taking XARELTO again after your surgery or procedure.
- If you need to stop taking XARELTO for any reason, talk to the doctor who prescribed XARELTO to you to find out when you should stop taking it. Do not stop taking XARELTO without first talking to the doctor who prescribes it to you.
- If you have difficulty swallowing XARELTO tablets whole, talk to your doctor about other ways to take XARELTO.
- Do not run out of XARELTO. Refill your prescription of XARELTO before you run out. When leaving the hospital following a hip or knee replacement, be sure that you will have XARELTO available to avoid missing any doses.
- If you take too much XARELTO, go to the nearest hospital emergency room or call your doctor right away.

If you take XARELTO for:

- **Atrial fibrillation that is not caused by a heart valve problem:**
 - Take XARELTO **1 time a day with your evening meal.**
 - If you miss a dose of XARELTO, take it as soon as you remember on the same day. Take your next dose at your regularly scheduled time.
- **Blood clots in the veins of your legs or lungs:**
 - Take XARELTO **1 or 2 times a day** as prescribed by your doctor.
 - For the **10 mg dose**, take XARELTO **with or without food.**
 - For the **15 mg and 20 mg doses**, take XARELTO **with food at the same time each day.**
 - If you miss a dose:
 - **If you take the 15 mg dose of XARELTO 2 times a day (a total of 30 mg of XARELTO in 1 day):** Take XARELTO as soon as you remember on the same day. You may take 2 doses at the same time to make up for the missed dose. Take your next dose at your regularly scheduled time.
 - **If you take XARELTO 1 time a day:** Take XARELTO as soon as you remember on the same day. Take your next dose at your regularly scheduled time.
- **Hip or knee replacement surgery:**
 - Take XARELTO 1 time a day with or without food.
 - If you miss a dose of XARELTO, take it as soon as you remember on the same day. Take your next dose at your regularly scheduled time.
- **Blood clots in people hospitalized for an acute illness:**
 - Take XARELTO 1 time a day, with or without food, while you are in the hospital and after you are discharged as prescribed by your doctor.
 - If you miss a dose of XARELTO, take it as soon as you remember on the same day. Take your next dose at your regularly scheduled time.
- **Reducing the risk of serious heart problems, heart attack and stroke in coronary artery disease or peripheral artery disease:**
 - Take XARELTO 2.5 mg 2 times a day with or without food.
 - If you miss a dose of XARELTO, take your next dose at your regularly scheduled time.
 - Take aspirin 75 to 100 mg once daily as instructed by your doctor.

What are the possible side effects of XARELTO?

XARELTO may cause serious side effects:

- See “What is the most important information I should know about XARELTO?”

The most common side effect of XARELTO was bleeding.

Call your doctor for medical advice about side effects. You may report side effects to FDA at 1 800-FDA-1088.

How should I store XARELTO?

- Store XARELTO at room temperature between 68°F to 77°F (20°C to 25°C).

Keep XARELTO and all medicines out of the reach of children.

General information about the safe and effective use of XARELTO.

Medicines are sometimes prescribed for purposes other than those listed in a Medication Guide. Do not use XARELTO for a condition for which it was not prescribed. Do not give XARELTO to other people, even if they have the same symptoms that you have. It may harm them. You can ask your pharmacist or doctor for information about XARELTO that is written for health professionals.

What are the ingredients in XARELTO?

Active ingredient: rivaroxaban

Inactive ingredients: croscarmellose sodium, hypromellose, lactose monohydrate, magnesium stearate, microcrystalline cellulose, and sodium lauryl sulfate.

The proprietary film coating mixture for XARELTO 2.5 mg tablets is Opadry® Light Yellow and contains: ferric oxide yellow, hypromellose, polyethylene glycol 3350, and titanium dioxide.

The proprietary film coating mixture for XARELTO 10 mg tablets is Opadry® Pink and contains: ferric oxide red, hypromellose, polyethylene glycol 3350, and titanium dioxide.

The proprietary film coating mixture for XARELTO 15 mg tablets is Opadry® Red and contains: ferric oxide red, hypromellose, polyethylene glycol 3350, and titanium dioxide.

The proprietary film coating mixture for XARELTO 20 mg tablets is Opadry® II Dark Red and contains: ferric oxide red, polyethylene glycol 3350, polyvinyl alcohol (partially hydrolyzed), talc, and titanium dioxide.

Finished Product Manufactured by: Janssen Ortho LLC Gurabo, PR 00778 or Bayer AG 51368 Leverkusen, Germany

Manufactured for: Janssen Pharmaceuticals, Inc. Titusville, NJ 08560 Licensed from: Bayer HealthCare AG 51368 Leverkusen, Germany

© 2011-2019 Janssen Pharmaceutical Companies

Trademarks are property of their respective owners.

For more information go to www.XARELTO-US.com or call 1-800-526-7736.

This Medication Guide has been approved by the U.S. Food and Drug Administration

Revised: 03/2020

PRODUCT MONOGRAPH

PrXELJANZ[®]
tofacitinib, tablets, oral
5 mg tofacitinib (as tofacitinib citrate)
10 mg tofacitinib (as tofacitinib citrate)

PrXELJANZ[®] XR
tofacitinib extended-release, tablets, oral
11 mg tofacitinib (as tofacitinib citrate)

ATC Code: L04AA29
Selective Immunosuppressant

Pfizer Canada ULC
17,300 Trans-Canada Highway
Kirkland, Quebec H9J 2M5

Date of Revision:
October 24, 2019

TMPF PRISM C.V.
c/o Pfizer Manufacturing Holdings LLC
Pfizer Canada ULC, Licensee
© Pfizer Canada ULC 2019

Submission Control No: 230976

Table of Contents

PART I: HEALTH PROFESSIONAL INFORMATION	3
SUMMARY PRODUCT INFORMATION	3
INDICATIONS AND CLINICAL USE.....	3
CONTRAINDICATIONS	4
ADVERSE REACTIONS.....	15
DRUG INTERACTIONS	28
DOSAGE AND ADMINISTRATION	34
OVERDOSAGE	38
ACTION AND CLINICAL PHARMACOLOGY	38
STORAGE AND STABILITY	45
DOSAGE FORMS, COMPOSITION AND PACKAGING	45
PART II: SCIENTIFIC INFORMATION	46
PHARMACEUTICAL INFORMATION.....	46
CLINICAL TRIALS	47
TOXICOLOGY	66
REFERENCES	76
PART III: CONSUMER INFORMATION	77

PrXELJANZ®
PrXELJANZ® XR
Tofacitinib tablets

PART I: HEALTH PROFESSIONAL INFORMATION

SUMMARY PRODUCT INFORMATION

Route of Administration	Dosage Form / Strength	Clinically Relevant Nonmedicinal Ingredients
Oral	<p>Tofacitinib tablets / 5 mg tofacitinib and 10 mg (as tofacitinib citrate)</p> <p>Tofacitinib extended-release tablets / 11 mg tofacitinib (as tofacitinib citrate)</p>	<p><i>For a complete listing see Dosage Forms, Composition and Packaging section.</i></p>

INDICATIONS AND CLINICAL USE

Rheumatoid Arthritis

XELJANZ/XELJANZ XR (tofacitinib), in combination with methotrexate (MTX), is indicated for reducing the signs and symptoms of rheumatoid arthritis (RA) in adult patients with moderately to severely active RA who have had an inadequate response to MTX.

In cases of intolerance to MTX, physicians may consider the use of XELJANZ/XELJANZ XR (tofacitinib) as monotherapy.

Limitations of Use: Use of XELJANZ/XELJANZ XR in combination with biological disease-modifying anti-rheumatic drugs (bDMARDs) or potent immunosuppressants such as azathioprine and cyclosporine is not recommended.

Psoriatic Arthritis

XELJANZ (tofacitinib), in combination with methotrexate (MTX) or another conventional synthetic disease-modifying antirheumatic drug (DMARD), is indicated for reducing the signs and symptoms of psoriatic arthritis (PsA) in adult patients with active PsA when the response to previous DMARD therapy has been inadequate.

Limitations of Use: Use of XELJANZ in combination with biological disease-modifying anti-rheumatic drugs (bDMARDs) or potent immunosuppressants such as azathioprine and cyclosporine is not recommended.

Ulcerative Colitis

XELJANZ (tofacitinib) is indicated for the treatment of adult patients with moderately to severely active ulcerative colitis (UC) with an inadequate response, loss of response or intolerance to either conventional UC therapy or a TNF α inhibitor.

Limitations of Use: Use of XELJANZ in combination with biological UC therapies or with potent immunosuppressants such as azathioprine and cyclosporine is not recommended.

Pediatrics (<18 years of age)

The safety and effectiveness of XELJANZ/XELJANZ XR in pediatric patients have not been established. Therefore, XELJANZ/XELJANZ XR should not be used in this patient population (see **DOSAGE AND ADMINISTRATION** and **ACTION AND CLINICAL PHARMACOLOGY**).

Geriatrics (>65 years of age)

The frequency of serious infection among XELJANZ treated subjects 65 years of age and older was higher than among those under the age of 65. Therefore, caution should be used when treating the elderly with XELJANZ/XELJANZ XR (see **WARNINGS AND PRECAUTIONS**, **DOSAGE AND ADMINISTRATION** and **ACTION AND CLINICAL PHARMACOLOGY**).

CONTRAINDICATIONS

XELJANZ/XELJANZ XR (tofacitinib) is contraindicated:

- In patients with known hypersensitivity to tofacitinib or any of its components. For a complete listing, see **DOSAGE FORMS, COMPOSITION AND PACKAGING** section of the product monograph.
- In patients with severe hepatic impairment.
- During pregnancy and breastfeeding.

WARNINGS AND PRECAUTIONS

WARNING: RISK OF SERIOUS INFECTIONS

Patients treated with XELJANZ/XELJANZ XR (tofacitinib) are at increased risk for developing serious infections that may lead to hospitalization or death. Most patients who developed these infections were taking concomitant immunosuppressants such as methotrexate or corticosteroids.

If a serious infection develops, interrupt XELJANZ/XELJANZ XR until the infection is controlled.

Reported infections include:

- **Active tuberculosis, which may present with pulmonary or extrapulmonary disease. Patients should be tested for latent tuberculosis before XELJANZ/XELJANZ XR use and during therapy. Treatment for latent infection should be initiated prior to XELJANZ/XELJANZ XR use.**
- **Invasive fungal infections, including cryptococcosis and pneumocystosis. Patients with invasive fungal infections may present with disseminated, rather than localized disease.**
- **Bacterial, viral, and other infections due to opportunistic pathogens.**

Treatment with XELJANZ/XELJANZ XR should not be initiated in patients with active infections including chronic or localized infection.

Patients should be closely monitored for the development of signs and symptoms of infection during and after treatment with XELJANZ/XELJANZ XR, including the possible development of tuberculosis in patients who tested negative for latent tuberculosis infection prior to initiating therapy (see ADVERSE REACTIONS).

MALIGNANCIES

Lymphoma and other malignancies have been observed in patients treated with XELJANZ. Epstein Barr Virus-associated post-transplant lymphoproliferative disorder has been observed at an increased rate in renal transplant patients treated with XELJANZ and concomitant immunosuppressive medications (see WARNINGS AND PRECAUTIONS).

THROMBOSIS

Rheumatoid arthritis patients with at least one cardiovascular (CV) risk factor had a higher rate of all-cause mortality and thrombosis, including pulmonary embolism, deep venous thrombosis, and arterial thrombosis, with XELJANZ 10 mg twice daily compared to those treated with 5 mg twice daily or TNF blockers. Many of these adverse events were serious and some resulted in death. Avoid XELJANZ/XELJANZ XR in patients at risk of thrombosis. Discontinue XELJANZ/XELJANZ XR and promptly evaluate patients with symptoms of thrombosis (see WARNINGS AND PRECAUTIONS, Cardiovascular).

For patients with ulcerative colitis (UC), use XELJANZ at the lowest effective dose and for the shortest duration needed to achieve/maintain therapeutic response (see DOSAGE AND ADMINISTRATION).

General

Specific to XELJANZ XR: As with any other non-deformable material, caution should be used when administering XELJANZ XR to patients with pre-existing severe gastrointestinal narrowing (pathologic or iatrogenic). There have been rare reports of obstructive symptoms in patients with known strictures in association with the ingestion of other drugs utilizing a non-deformable extended release formulation.

Cardiovascular

Heart Rate Decrease and PR Interval Prolongation: XELJANZ caused a decrease in heart rate and a prolongation of the PR interval (see **WARNINGS AND PRECAUTIONS – Monitoring and Laboratory Tests** and **ADVERSE REACTIONS**). Caution should be observed in patients with a low heart rate at baseline (<60 beats per minute), a history of syncope or arrhythmia, sick sinus syndrome, sinoatrial block, atrioventricular (AV) block, ischemic heart disease, or congestive heart failure. Concomitant medications that result in a decrease in heart rate and/or PR interval prolongation should be avoided to the extent possible during treatment with XELJANZ/XELJANZ XR (see **DRUG INTERACTIONS**).

Thrombosis

Thrombosis, including pulmonary embolism, deep venous thrombosis, and arterial thrombosis, was observed at an increased incidence in patients treated with XELJANZ in a large, ongoing post-marketing study. Rheumatoid arthritis (RA) patients 50 years of age and older with at least one cardiovascular (CV) risk factor treated with XELJANZ 10 mg twice a day had a higher rate of all-cause mortality, including sudden CV death, and thrombosis compared to those treated with XELJANZ 5 mg given twice daily or TNF blockers. Many of these events were serious and some resulted in death (see **SERIOUS WARNINGS AND PRECAUTIONS BOX**).

In a long-term extension study in patients with ulcerative colitis (UC), four cases of pulmonary embolism were reported in patients taking XELJANZ 10 mg twice daily, including one death in a patient with advanced cancer.

A dosage of XELJANZ 10 mg twice daily or XELJANZ XR 22 mg once daily is not recommended for the treatment of RA or psoriatic arthritis (PsA) (see **DOSAGE AND ADMINISTRATION**).

For the treatment of UC, use XELJANZ at the lowest effective dose and for the shortest duration needed to achieve/maintain therapeutic response (see **DOSAGE AND ADMINISTRATION**).

Avoid XELJANZ/XELJANZ XR in patients that may be at increased risk of thrombosis. Discontinue XELJANZ/XELJANZ XR and promptly evaluate patients with symptoms of thrombosis.”

Gastrointestinal Perforations

Events of gastrointestinal perforation have been reported with XELJANZ in rheumatoid arthritis patients, although the role of JAK inhibition in these events is not known. Many patients who developed gastrointestinal perforations were taking concomitant nonsteroidal anti-inflammatory drugs (NSAIDs) and/or corticosteroids. The relative contribution of these concomitant medications versus XELJANZ to the development of gastrointestinal perforations is not known.

There was no discernable difference in frequency of gastrointestinal perforation between the placebo and the XELJANZ arms in clinical trials of patients with ulcerative colitis (UC), and many of them were receiving background corticosteroids.

XELJANZ/XELJANZ XR should be used with caution in patients who may be at increased risk for gastrointestinal perforation (e.g., use of concomitant NSAIDs and/or corticosteroids, patients with a history of diverticulitis). Patients presenting with new onset abdominal symptoms should be evaluated promptly for early identification of gastrointestinal perforation (see **ADVERSE REACTIONS**).

Hepatic/Biliary/Pancreatic

XELJANZ/XELJANZ XR is contraindicated in patients with severe hepatic impairment.

Treatment with XELJANZ was associated with an increased incidence of liver enzyme elevation compared to placebo (see **WARNINGS AND PRECAUTIONS – Laboratory parameters and ADVERSE REACTIONS**).

Evaluate liver enzymes before initiating XELJANZ and thereafter according to routine patient management (see **WARNINGS AND PRECAUTIONS – Monitoring and Laboratory Tests**). Prompt investigation of the causes of liver enzyme elevations is recommended to identify potential cases of drug-induced liver injury (DILI). If increases in ALT (alanine transaminase) or AST (aspartate transaminase) are observed and DILI is suspected, the administration of XELJANZ/XELJANZ XR should be interrupted until the diagnosis is excluded.

Most of the liver enzyme abnormalities in RA and PsA patients occurred in studies with background DMARD (primarily methotrexate) therapy.

One case of DILI was reported in a RA patient treated with tofacitinib 10 mg BID for approximately 2.5 months. The patient developed symptomatic elevations of AST and ALT with values greater than 3x ULN associated concurrently with total bilirubin value greater than 2x ULN, which required hospitalization and a liver biopsy.

In UC patients, XELJANZ treatment with 5 and 10 mg BID was also associated with an increased incidence of liver enzyme elevation compared to placebo, with a trend for higher incidence with the 10 mg BID as compared to the 5 mg BID (see **WARNINGS AND PRECAUTIONS – Laboratory parameters and ADVERSE REACTIONS**).

The impact of XELJANZ/XELJANZ XR on chronic viral hepatitis reactivation is unknown. XELJANZ/XELJANZ XR has not been studied in patients with positive hepatitis B virus or hepatitis C virus serology, and should therefore not be used in these populations.

XELJANZ/XELJANZ XR has not been studied in patients with severe hepatic impairment, and should not be used in these patients. XELJANZ XR should not be used in patients with moderate to severe hepatic impairment. Dose adjustment of XELJANZ is recommended for patients with moderate hepatic impairment (see **DOSAGE AND ADMINISTRATION** and **ACTION AND CLINICAL PHARMACOLOGY**).

Immune

Hypersensitivity Reactions: Reactions such as angioedema and urticaria that may reflect drug hypersensitivity have been observed in patients treated with XELJANZ/XELJANZ XR. Some events were serious. If a hypersensitivity reaction is suspected, promptly discontinue tofacitinib while evaluating the potential cause or causes of the reaction (see **CONTRAINDICATIONS** and **ADVERSE REACTIONS**).

Immunocompromised Patients: XELJANZ/XELJANZ XR can increase the risk of infections and immunosuppression when co-administered with potent immunosuppressants such as cyclosporine, azathioprine and tacrolimus. Combined use of XELJANZ/XELJANZ XR with potent immunosuppressive drugs has not been studied and is not recommended (see **DRUG INTERACTIONS**).

Immunizations

No data are available on the secondary transmission of infection by live vaccines to patients receiving XELJANZ/XELJANZ XR. It is recommended that all patients be brought up to date with all immunizations in agreement with current immunization guidelines prior to initiating XELJANZ/XELJANZ XR therapy and that live vaccines not be given concurrently with XELJANZ/XELJANZ XR. The interval between live vaccinations and initiation of tofacitinib therapy should be in accordance with current vaccination guidelines regarding immunomodulatory agents.

In patients being considered for XELJANZ/XELJANZ XR therapy, live zoster vaccine should only be administered to patients with a known history of chickenpox or those that are seropositive for varicella zoster virus. Vaccination should occur at least 2 weeks but preferably 4 weeks before initiating immunomodulatory agents such as XELJANZ/XELJANZ XR.

In a clinical trial, a varicella naïve patient treated with XELJANZ and methotrexate developed disseminated infection with the vaccine strain of the varicella zoster virus 16 days after vaccination. A satisfactory immune response to the vaccine was developed 6 weeks post-vaccination.

In a randomized, double-blind, placebo-controlled study in 200 adult RA patients treated with XELJANZ 10 mg BID or placebo, humoral responses to concomitant pneumococcal and influenza vaccines were assessed. The percentages of patients achieving a satisfactory humoral response to pneumococcal vaccines were lower for the XELJANZ group than the placebo group. This effect was more pronounced for patients receiving background methotrexate. A total of 31.6% XELJANZ-treated subjects and 61.8% placebo-treated subjects who received background

methotrexate achieved a ≥ 2 -fold increase in antibody concentrations to ≥ 6 of 12 pneumococcal antigens.

In the same study, the proportion of patients achieving protective antibody levels to the influenza antigens was lower in the XELJANZ group (64.9%) compared to the placebo group (92.7%) in patients receiving background methotrexate. However, the difference in humoral response to the influenza vaccine was small with 50.9% of patients in the XELJANZ group and 58.2% in the placebo group with background methotrexate achieving a ≥ 4 -fold increase in antibody titers to ≥ 2 of 3 influenza antigens.

Infections

Serious and sometimes fatal infections due to bacterial, mycobacterial, invasive fungal, viral, or other opportunistic pathogens have been reported in rheumatoid arthritis patients receiving immunomodulatory agents, including biologic DMARDs and XELJANZ. The most common serious infections reported with XELJANZ included pneumonia, cellulitis, herpes zoster, urinary tract infection, diverticulitis, and appendicitis. Among opportunistic infections, tuberculosis and other mycobacterial infections, cryptococcus, histoplasmosis, esophageal candidiasis, pneumocystosis, multidermatomal herpes zoster, cytomegalovirus infections, BK virus infections, and listeriosis were reported with XELJANZ (see **ADVERSE REACTIONS**). Some patients have presented with disseminated rather than localized disease, and were often taking concomitant immunomodulating agents such as methotrexate or corticosteroids. Other serious infections that were not reported in clinical studies may also occur (e.g., coccidioidomycosis).

Patients treated with XELJANZ 10 mg BID are at higher risk of serious infections, and herpes zoster infections compared to those treated with 5 mg BID. The incidence rate per 100 person-years (PYs) for herpes zoster opportunistic infections in the UC 52-week maintenance study was higher in patients treated with XELJANZ 10 mg BID (6.64) as compared to XELJANZ 5 mg BID (2.05) or placebo (0.97) (see **ADVERSE REACTIONS**).

XELJANZ/XELJANZ XR should not be administered in patients with an active infection, including localized infections. The risks and benefits of treatment should be considered prior to initiating XELJANZ/XELJANZ XR in patients:

- with chronic or recurrent infections,
- who have been exposed to tuberculosis,
- with a history of a serious or an opportunistic infection,
- who have resided or travelled in areas of endemic tuberculosis or endemic mycoses; or
- with underlying conditions that may predispose them to infection.

Patients should be closely monitored for the development of signs and symptoms of infection during and after treatment with XELJANZ/XELJANZ XR. XELJANZ/XELJANZ XR should be interrupted if a patient develops a serious infection, an opportunistic infection, or sepsis. A patient who develops a new infection during treatment with XELJANZ/XELJANZ XR should undergo prompt and complete diagnostic testing appropriate for an immunocompromised patient, appropriate antimicrobial therapy should be initiated, and the patient should be closely monitored.

As there is a higher incidence of infections in the elderly and in the diabetic populations in general, caution should be used when treating the elderly and patients with diabetes. Caution is also recommended in patients with a history of chronic lung disease as they may be more prone to infections. Events of interstitial lung disease (some of which had a fatal outcome) have been reported in RA patients treated with XELJANZ in clinical trials and in the post-marketing setting.

Risk of infection may be higher with increasing degrees of lymphopenia and consideration should be given to lymphocyte counts when assessing individual patient risk of infection.

For discontinuation and monitoring criteria for lymphopenia see **WARNINGS AND PRECAUTIONS – Monitoring and Laboratory Tests**.

Treatment with XELJANZ was associated with increased rates of infections in Asian patients compared to other races (see **WARNINGS AND PRECAUTIONS – Special Populations and ADVERSE REACTIONS**). XELJANZ/XELJANZ XR should be used with caution in this population.

Tuberculosis

Patients should be evaluated and tested for latent or active infection prior to administration of XELJANZ/XELJANZ XR and periodically (e.g. annually) while taking XELJANZ/XELJANZ XR.

Patients should be closely monitored for the development of signs and symptoms of tuberculosis, including patients who tested negative for latent tuberculosis infection prior to initiating therapy.

Antituberculosis therapy should also be considered prior to administration of XELJANZ/XELJANZ XR in patients with a past history of latent or active tuberculosis in whom an adequate course of treatment cannot be confirmed, and for patients with a negative test for latent tuberculosis but have risk factors for tuberculosis infection.

Patients with latent tuberculosis should be treated with standard antimycobacterial therapy before administering XELJANZ/XELJANZ XR.

Viral Reactivation

Viral reactivation, including cases of herpes virus reactivation (e.g., herpes zoster) were observed in clinical studies with XELJANZ. Post-marketing cases of hepatitis B reactivation have been reported in patients treated with XELJANZ (see **ADVERSE REACTIONS**). The impact of XELJANZ/XELJANZ XR on chronic viral hepatitis reactivation is unknown. Patients who screened positive for hepatitis B or C were excluded from clinical trials. Screening for viral hepatitis should be performed in accordance with clinical guidelines before starting therapy with XELJANZ/XELJANZ XR.

Laboratory Parameters

Lymphopenia: Treatment with XELJANZ was associated with initial lymphocytosis at one month of exposure followed by a gradual decrease in mean lymphocyte counts below the baseline of approximately 10% during 12 months of therapy. Lymphocyte counts less than 500 cells/mm³ were associated with an increased incidence of treated and serious infections.

Avoid initiation of XELJANZ/XELJANZ XR treatment in patients with a low lymphocyte count (i.e., less than 500 cells/mm³). In patients who develop a confirmed absolute lymphocyte count less than 500 cells/mm³, XELJANZ/XELJANZ XR should be discontinued.

For recommended monitoring and dose modifications based on lymphocyte counts see **WARNINGS AND PRECAUTIONS – Monitoring and Laboratory Tests** and **DOSAGE AND ADMINISTRATION**.

Neutropenia: Treatment with XELJANZ was associated with an increased incidence of neutropenia (<2000/mm³) compared to placebo.

Avoid initiation of XELJANZ/XELJANZ XR treatment in patients with a low neutrophil count (i.e., ANC (absolute neutrophil count) <1000/mm³). For patients who develop a persistent ANC of 500-1000/mm³, interrupt dosing until ANC is >1000 cells/mm³. In patients who develop an absolute neutrophil count <500 cells/mm³, discontinue treatment.

For recommended monitoring and dose modification based on ANC, see **WARNINGS AND PRECAUTIONS – Monitoring and Laboratory Tests** and **DOSAGE AND ADMINISTRATION**.

Anemia: Treatment with tofacitinib has been associated with decreases in hemoglobin levels. Avoid initiation of XELJANZ/XELJANZ XR treatment in patients with low hemoglobin values (i.e., <9 g/dL). Treatment with XELJANZ/XELJANZ XR should be interrupted in patients who develop hemoglobin levels <8 g/dL or whose hemoglobin level drops >2 g/dL on treatment.

For recommended monitoring and dose modification based on hemoglobin results, see **WARNINGS AND PRECAUTIONS – Monitoring and Laboratory Tests** and **DOSAGE AND ADMINISTRATION**.

Liver Enzyme Elevations: Treatment with XELJANZ was associated with an increased incidence of liver enzyme elevation compared to placebo (see **WARNINGS AND PRECAUTIONS – Hepatic/Biliary/Pancreatic**, and **ADVERSE REACTIONS**). Most of these abnormalities in RA and PsA patients occurred in studies with background DMARD (primarily methotrexate) therapy.

In UC patients, XELJANZ treatment with 5 and 10 mg BID was also associated with an increased incidence of liver enzyme elevation compared to placebo, with a trend for higher incidence with the 10 mg BID dose as compared to the 5 mg BID dose.

One patient treated with XELJANZ 10 mg BID in the maintenance UC study experienced an increase in liver enzymes which decreased upon discontinuation of treatment. The case was adjudicated as possible DILI, while noting ultrasound findings of fatty liver.

Routine monitoring of liver enzymes and prompt investigation of the cause of liver enzyme elevations is recommended to identify potential cases of DILI (see **WARNINGS AND PRECAUTIONS – Monitoring and Laboratory Tests**).

Lipid Elevations: Treatment with XELJANZ was associated with increases in lipid parameters including total cholesterol, low-density lipoprotein (LDL) cholesterol, and high-density lipoprotein (HDL) cholesterol (see **ADVERSE REACTIONS**).

Maximum effects were generally observed within 6 weeks. The effect of these lipid parameter elevations on cardiovascular morbidity and mortality has not been determined.

Assessment of lipid parameters should be performed at baseline and approximately 4-8 weeks following initiation of XELJANZ/XELJANZ XR therapy, and every 6 months thereafter (see **WARNINGS AND PRECAUTIONS – Monitoring and Laboratory Tests**). Patients should be managed according to local clinical guidelines for the management of hyperlipidemia.

Malignancies and Lymphoproliferative Disorder

Malignancies have been observed in patients treated with XELJANZ. In patients treated with XELJANZ, malignancies were observed in clinical studies and the post-marketing setting including but not limited to: lymphomas, lung cancer, breast cancer, colorectal cancer, gastric cancer, melanoma, prostate cancer, pancreatic cancer and renal cell carcinoma.

Consider the risks and benefits of XELJANZ/XELJANZ XR treatment prior to initiating therapy in patients with current or a history of malignancy other than a successfully treated non-melanoma skin cancer (NMSC) or when considering continuing XELJANZ/XELJANZ XR in patients who develop a malignancy. Recommendations for non-melanoma skin cancer are presented below.

Rheumatoid Arthritis

In the 5 controlled clinical studies, 5 malignancies (excluding non-melanoma skin cancers (NMSC)) were diagnosed in patients receiving XELJANZ 5 mg BID, and 8 malignancies (excluding NMSC) were diagnosed in patients receiving XELJANZ 10 mg BID, compared to 0 malignancies (excluding NMSC) in patients in the placebo/placebo plus DMARD group during the first 12 months. Lymphomas and solid cancers have also been observed in the long-term extension study in patients treated with XELJANZ (see **ADVERSE REACTIONS**). Patients with RA particularly those with highly active disease, may be at a higher risk (several fold) than the general population for the development of lymphoma.

In Phase 2B, controlled dose-ranging trials in de-novo renal transplant patients, all of whom received induction therapy with basiliximab, high dose corticosteroids, and mycophenolic acid products, Epstein Barr Virus-associated post-transplant lymphoproliferative disorder was observed in 5 out of 218 patients treated with XELJANZ (2.3%) compared to 0 out of 111 patients treated with cyclosporine.

Psoriatic Arthritis

In the 2 controlled PsA clinical trials, there were 3 malignancies (excluding NMSC) in 474 patients receiving XELJANZ plus csDMARD (6 to 12 months exposure) compared with 0 malignancies in 236 patients in the placebo plus csDMARD group (3 months exposure) and 0 malignancies in 106

patients in the adalimumab plus csDMARD group (12 months exposure). Malignancies have also been observed in the long-term extension study in PsA patients treated with XELJANZ.

Ulcerative Colitis

In the 4 controlled clinical studies for ulcerative colitis (up to 52-week treatment), no malignancies (excluding NMSC) were reported with XELJANZ. In the long-term extension open-label study, malignancies (excluding NMSC) have been observed in patients treated with XELJANZ 10 mg BID, including solid cancers and lymphoma.

Non-Melanoma Skin Cancer: Non-melanoma skin cancers (NMSCs) have been reported in patients treated with XELJANZ. NMSC is a dose related adverse reaction, with a greater risk in patients treated with 10 mg BID of XELJANZ than in patients treated with 5 mg BID. Periodic skin examination is recommended.

In the UC 52-week maintenance study, NMSC was reported in 3 patients (1.5%) treated with 10 mg BID, as compared with no reported events in patients treated with 5 mg BID and 1 patient (0.5%) treated with placebo. In the long-term open label extension study, NMSC was reported in 6 patients in the 10 mg BID group and 2 patients in the 5 mg BID group.

Monitoring and Laboratory Tests

Lipid tests should be performed at baseline, approximately 4-8 weeks after initiation with XELJANZ/XELJANZ XR and every 6 months thereafter.

Liver enzymes tests are recommended. If DILI is suspected, the administration of XELJANZ/XELJANZ XR should be interrupted until this diagnosis has been excluded.

Assessment of renal function is recommended prior to initiation of XELJANZ/XELJANZ XR (see **DOSAGE AND ADMINISTRATION**).

Lymphocyte, neutrophil and hemoglobin tests should be performed at baseline, approximately 4-8 weeks after initiation with XELJANZ/XELJANZ XR treatment, and every 3 months thereafter (see **DOSAGE AND ADMINISTRATION** for recommended dose adjustment based on these laboratory tests).

Vital signs: Patients should be monitored for pulse rate and blood pressure at baseline and periodically during treatment with XELJANZ/XELJANZ XR (see **WARNINGS AND PRECAUTIONS – Cardiovascular, ADVERSE REACTIONS, and DRUG INTERACTIONS**).

Musculoskeletal

Treatment with XELJANZ was associated with increases in creatine kinase (CK). Maximum effects were generally observed within 6 months. Rhabdomyolysis was reported in one patient treated with XELJANZ. Creatine kinase levels should be checked in patients with symptoms of muscle weakness and/or muscle pain to evaluate for evidence of rhabdomyolysis. Increases in CK were reported more frequently in patients treated with XELJANZ 10 mg as compared to those treated with 5 mg BID (see **ADVERSE REACTIONS**).

Renal

XELJANZ XR is not recommended in patients with moderate ($CL_{Cr} \geq 30$ and < 60 mL/min), or severe renal insufficiency ($CL_{Cr} \geq 15$ and < 30 mL/min), including patients with end-stage renal disease (ESRD) but not limited to those undergoing hemodialysis.

Dosage adjustment of XELJANZ is recommended in patients with moderate and severe renal impairment (see **WARNINGS AND PRECAUTIONS – Special Populations, DOSAGE AND ADMINISTRATION, and ACTION AND CLINICAL PHARMACOLOGY**). In clinical trials, XELJANZ was not evaluated in patients with baseline creatinine clearance values (estimated by the Cockcroft-Gault equation) less than 40 mL/min.

Respiratory

Interstitial Lung Disease: Events of interstitial lung disease (ILD) have been reported in RA clinical trials with XELJANZ, although the role of JAK inhibition in these events is not known. All patients who developed ILD were taking concomitant methotrexate, corticosteroids and/or sulfasalazine, which have been associated with ILD. Asian patients had an increased risk of ILD (see **WARNINGS AND PRECAUTIONS – Special Populations**).

XELJANZ/XELJANZ XR should be used with caution in patients with a risk or history of ILD.

Special Populations

Pregnant Women: XELJANZ/XELJANZ XR is contraindicated during pregnancy (see **CONTRAINDICATIONS**). There are no adequate and well-controlled studies on the use of XELJANZ/XELJANZ XR in pregnant women. XELJANZ has been shown to be teratogenic in rats and rabbits, and have effects in rats on female fertility, parturition, and peri/postnatal development (see **TOXICOLOGY**).

Women of reproductive potential should be advised to use effective contraception during XELJANZ/XELJANZ XR treatment and for 4 to 6 weeks after the last dose.

Nursing Women: XELJANZ was secreted in milk of lactating rats. It is not known whether XELJANZ/XELJANZ XR is excreted in human milk. XELJANZ/XELJANZ XR is contraindicated in women who breastfeed (see **CONTRAINDICATIONS** and **TOXICOLOGY**).

Pediatrics (<18 years of age): The safety and effectiveness of XELJANZ/XELJANZ XR in pediatric patients have not been established. Therefore, XELJANZ/XELJANZ XR should not be used in this patient population (see **ACTION AND CLINICAL PHARMACOLOGY**).

Geriatrics (>65 years of age): The frequency of serious infection among XELJANZ treated subjects 65 years of age and older was higher than among those under the age of 65. Caution should be used when treating the elderly with XELJANZ/XELJANZ XR (see **DOSAGE AND ADMINISTRATION** and **ACTION AND CLINICAL PHARMACOLOGY**).

Asian Patients: Asian patients have an increased risk of herpes zoster and opportunistic infections. Asian patients with RA also have an increased risk of interstitial lung disease. An increased incidence of some adverse events such as elevated transaminases (ALT, AST) and decreased white

blood cells (WBCs) were also observed. Therefore, XELJANZ/XELJANZ XR should be used with caution in Asian patients (see **ADVERSE REACTIONS**).

ADVERSE REACTIONS

Adverse Drug Reaction Overview

Rheumatoid Arthritis

During controlled clinical trials, 8.0% (11.0 events/100 patient-years) of patients in the 5 mg BID in the XELJANZ group were hospitalized due to serious adverse reactions compared to 7.8% (9.1 events/100 patient-years) and 3.8% (13.0 events/100 patient-years) of patients in the adalimumab and placebo group, respectively.

The most common serious adverse reactions (SAEs) were osteoarthritis and serious infections, including pneumonia, cellulitis, herpes zoster, and urinary tract infection. During the first 3 months, serious infections (those requiring parenteral antibiotics or hospitalization) were reported in 0.7% (2.8 events/100 patient-years) and 0.2% (0.6 events/100 patient-years) of patients treated with XELJANZ or placebo, respectively. From 0-12 months, serious infections were reported in 2.4% (3.2 events/100 patient-years) of XELJANZ treated patients (see **WARNINGS AND PRECAUTIONS**).

Deaths occurred in 0.4% (0.6 events/100 patient-years) of patients in the 5 mg BID XELJANZ group, compared to 0.5% (0.6 events/100 patient-years) and 0.2% (0.5 events/100 patient-years) of patients in the adalimumab and placebo groups, respectively.

The most commonly reported adverse reactions during the first 3 months in controlled clinical trials (occurring in $\geq 2\%$ of patients treated with XELJANZ monotherapy or in combination with DMARDs) were upper respiratory tract infections, headache, nasopharyngitis, and diarrhea. Additionally, bronchitis, urinary tract infection, herpes zoster, rheumatoid arthritis, back pain and hypertension were also reported in the 5 mg BID XELJANZ group in the long-term extension trial.

The proportion of patients who discontinued treatment due to any adverse reactions during the first 3 months in double-blind placebo-controlled studies was 7.8% for patients taking 5 mg BID of XELJANZ and 3.7% for placebo-treated patients. In the long-term extension trial, the proportion of patients who discontinued treatment due to any adverse reaction was 24.8% (6.78 events/100 patient-years) for all patients, 27.9% (6.67 events/100 patient-years) for patients taking 5 mg BID of XELJANZ, and 23.8% (6.83 events/100 patient-years) for patients taking 10 mg BID of tofacitinib. The most common adverse reactions that resulted in discontinuation of XELJANZ were infections. Pneumonia was the most common adverse reactions leading to discontinuation of therapy, followed by blood creatinine increased and herpes zoster.

Following completion of the Phase 2/3, open-label, uncontrolled, long-term extension follow-up trial (up to 114 months) from the Phase 2 studies and Phase 3 clinical program, there were 4040 subjects with 16113 patient-years of exposure to tofacitinib. The design of the long-term safety studies allowed for modification of XELJANZ doses according to clinical judgment. This limits the interpretation of the long-term safety data with respect to dose. Tofacitinib 10 mg BID

is not recommended in RA patients. Overall, the safety profile of XELJANZ 5 mg BID in the long-term extension study was comparable to what was seen in the controlled clinical trials.

Asian Patients: Asian patients had higher rates of herpes zoster, opportunistic infections, elevated transaminases (ALT, AST) and decreased WBCs. Asian patients with RA also have an increased risk of interstitial lung disease. Therefore, XELJANZ/XELJANZ XR should be used with caution in Asian patients.

Psoriatic Arthritis

The safety data includes 2 double-blind, controlled, multicenter studies: study PsA-I (A3921091) with a 12-month duration and study PsA-II (A3921125) with a 6-month duration; both included a 3-month placebo-controlled period. All patients in the clinical studies were required to receive treatment with a stable dose of a csDMARD. An additional long-term, open-label clinical study was conducted and included patients with PsA who originally participated in either of the 2 double-blind, controlled clinical studies.

A total of 783 patients were treated with any dose of XELJANZ in PsA clinical studies resulting in 1238 patient-years of exposure. Of these, 635 patients were exposed to XELJANZ for at least one year.

The most common serious adverse reactions were serious infections. The most commonly reported adverse reactions ($\geq 2\%$) in patients treated with XELJANZ 5 mg BID during the first 3 months in placebo-controlled clinical studies were bronchitis, diarrhea, dyspepsia, headache, nasopharyngitis, nausea.

The proportion of patients who discontinued treatment due to any adverse reactions during the first 3-months of the double-blind placebo-controlled studies was 3.2% for XELJANZ-treated patients and 2.5% for placebo-treated patients.

Overall, the safety profile observed in patients with active PsA treated with XELJANZ was consistent with the safety profile observed in patients with RA treated with XELJANZ.

Ulcerative Colitis

Four randomized, double-blind, placebo-controlled studies and one open-label study were conducted in patients with moderately to severely active UC: two similar 8-week pivotal Phase 3 induction studies (OCTAVE Induction 1 and 2), one 52-week pivotal Phase 3 maintenance study (OCTAVE Sustain), and one dose-ranging Phase 2 induction study (A3921063). A long-term open-label uncontrolled extensions study was also conducted (see **CLINICAL TRIALS**). In the 52-week OCTAVE Sustain study, 99 patients were treated with 5 mg BID and 113 patients with 10 mg BID for 52 weeks.

In the induction studies, the most common categories of serious adverse events were gastrointestinal disorders and infections. The most common serious adverse events (excluding events reported as ulcerative colitis) were abdominal pain, anal abscess, and drug hypersensitivity. The most common adverse events ($\geq 5\%$) were headache and nasopharyngitis.

In the maintenance study, the most common categories of serious adverse events were gastrointestinal disorders, infections, injuries, and nervous system disorders. All serious adverse events were single reports (excluding events reported as ulcerative colitis). The most common adverse events ($\geq 5\%$) (excluding events reported as ulcerative colitis) in patients treated with 5 mg BID were nasopharyngitis, arthralgia, headache, and upper respiratory tract infection. In patients treated with 10 mg BID, the most common adverse events were nasopharyngitis, arthralgia, blood creatine phosphokinase increased, upper respiratory tract infection, rash, hypercholesterolemia, and herpes zoster.

In induction studies, adverse events were reported in 515 subjects (54.9%) treated with 10 mg BID and 155 subjects (55.0%) treated with placebo. In the maintenance study, adverse events were reported in 143 subjects (72.2%) treated with 5 mg BID, 156 subjects (79.6%) treated with 10 mg BID, and 149 subjects (75.3%) treated with placebo.

In induction and maintenance studies, the most frequent reason for study discontinuation was worsening of ulcerative colitis. Excluding discontinuations due to worsening of ulcerative colitis, the proportion of patients who discontinued due to adverse reactions was less than 5% in any of the XELJANZ or placebo treatment groups in these studies.

Four cases of pulmonary embolism were reported in patients taking XELJANZ 10 mg twice daily.

Overall, the safety profile observed in UC patients treated with XELJANZ was consistent with the safety profile of XELJANZ across indications. Dose-dependent risks seen in patients treated with XELJANZ 10 mg BID in comparison with 5 mg BID include the following: herpes zoster infections, serious infections, and NMSC.

Clinical Trial Adverse Drug Reactions

Because clinical trials are conducted under very specific conditions the adverse reaction rates observed in the clinical trials may not reflect the rates observed in practice and should not be compared to the rates in the clinical trials of another drug. Adverse drug reaction information from clinical trials is useful for identifying drug-related adverse events and for approximating rates.

Rheumatoid Arthritis

Table 1 below lists the adverse events (regardless of causality) occurring in $\geq 1\%$ of patients treated with XELJANZ during the double-blind, placebo-controlled portion of the RA studies.

Table 1: Summary of Adverse Events Reported by $\geq 1\%$ of RA Patients Treated with XELJANZ (All Causalities) - All Phase 3 Studies (up to 3 months)

Body System/Adverse Event	XELJANZ 5mg BID (N=1216)	Placebo (N=681)	Adalimumab 40 mg SC q2w (N=204)
Infections and infestations			
Upper respiratory tract infection	53 (4.4)	23 (3.4)	7 (3.4)
Nasopharyngitis	48 (3.9)	19 (2.8)	7 (3.4)
Urinary tract infection	25 (2.1)	12 (1.8)	7 (3.4)
Bronchitis	14 (1.2)	10 (1.5)	4 (2.0)

Body System/Adverse Event	XELJANZ 5mg BID (N=1216)	Placebo (N=681)	Adalimumab 40 mg SC q2w (N=204)
Blood and lymphatic system disorders			
Anemia	15 (1.2)	8 (1.2)	0
Metabolism and nutrition disorders			
Hypercholesterolaemia	12 (1.0)	3 (0.4)	1 (0.5)
Nervous system disorders			
Headache	54 (4.4)	15 (2.2)	5 (2.5)
Dizziness	13 (1.1)	8 (1.2)	3 (1.5)
Vascular disorders			
Hypertension	20 (1.6)	7 (1.0)	0
Gastrointestinal disorders			
Diarrhoea	45 (3.7)	16 (2.3)	2 (1.0)
Nausea	32 (2.6)	18 (2.6)	3 (1.5)
Dyspepsia	19 (1.6)	11 (1.6)	3 (1.5)
Abdominal pain upper	23 (1.9)	5 (0.7)	3 (1.5)
Vomiting	21 (1.7)	10 (1.5)	0
Constipation	16 (1.3)	6 (0.9)	2 (1.0)
Gastritis	12 (1.0)	7 (1.0)	0
Gastroenteritis	12 (1.0)	5 (0.7)	0
Hepatobiliary Disorders			
Alanine aminotransferase increased	14 (1.2)	7 (1.0)	1 (0.5)
Musculoskeletal and connective tissue disorders			
Rheumatoid arthritis	17 (1.4)	17 (2.5)	1 (0.5)
Back pain	18 (1.5)	5 (0.7)	1 (0.5)
Arthralgia	13 (1.1)	16 (2.3)	4 (2.0)
General disorders and administration site conditions			
Oedema peripheral	17 (1.4)	16 (2.3)	3 (1.5)
Pyrexia	13 (1.1)	5 (0.7)	1 (0.5)

Psoriatic Arthritis

The incidence rates and types of adverse drug reactions reported in the two controlled Phase 3 PsA clinical studies were generally similar to those reported in RA clinical studies.

Ulcerative Colitis

Table 2 below lists adverse drug reactions reported by $\geq 1\%$ of patients treated with XELJANZ – UC Phase 2 and Phase 3 Induction Studies

Table 2: Summary of Adverse Drug Reactions (adverse events for which there is evidence of causality) Reported by $\geq 1\%$ of Patients Treated with XELJANZ – UC Phase 2 and Phase 3 Induction Studies (up to 8 weeks)

Body System [±] /Adverse Drug Reaction	XELJANZ 10 mg BID (N=938)	Placebo (N=282)
Subjects with one or more ADR (%)	494 (52.7)	130 (46.1)
Blood and lymphatic system disorders		
Anemia	22 (2.3)	9 (3.2)
Gastrointestinal disorders		
Nausea	28 (3.0)	11 (3.9)

Body System[±]/Adverse Drug Reaction	XELJANZ 10 mg BID (N=938)	Placebo (N=282)
Abdominal pain	25 (2.7)	11 (3.9)
Vomiting	9 (1.0)	3 (1.1)
Dyspepsia	12 (1.3)	1(0.4)
General disorders and administration site conditions	48 (5.1)	13 (4.6)
Fatigue	17 (1.8)	5 (1.8)
Pyrexia	24 (2.6)	4 (1.4)
Infections and infestations	111 (11.8)	24 (8.5)
Nasopharyngitis	56 (6.0)	14 (5.0)
Influenza	9 (1.0)	3 (1.1)
Urinary tract infection	11 (1.2)	1 (0.4)
Pharyngitis	10 (1.1)	1 (0.4)
Investigations	65 (6.9)	4 (1.4)
Blood creatine phosphokinase increased	25 (2.7)	3 (1.1)
Elevated cholesterol levels*	31 (3.3)	0
Musculoskeletal and connective tissue disorders	33 (3.5)	12 (4.3)
Arthralgia	27 (2.9)	12 (4.3)
Nervous system disorders	77 (8.2)	20 (7.1)
Headache	73 (7.8)	19 (6.7)
Respiratory	14 (1.5)	8 (2.8)
Cough	13 (1.4)	7 (2.5)
Skin and Subcutaneous Tissue Disorders	18 (1.9)	9 (3.2)
Rash	12 (1.3)	2 (0.7)
Vascular disorders	9 (1.0)	1 (0.4)
Hypertension	9 (1.0)	1 (0.4)

* includes: hypercholesterolemia, hyperlipidemia, blood cholesterol increased, dyslipidemia, blood triglycerides increased, low density lipoprotein increased, low density lipoprotein abnormal, or lipids increased.

± the total number of subjects with adverse reactions and the total number of subjects with adverse reactions for each body system include all adverse drug reactions (those reported by ≥1% of subjects treated with XELJANZ and those reported by <1% of subjects treated with XELJANZ); the total also includes some subjects who reported more than one adverse drug reaction (which inflates the percentage).

Table 3: Summary of Adverse Drug Reactions (adverse events for which there is evidence of causality) Reported by ≥1% of Patients Treated with XELJANZ – UC Phase 3 Maintenance Study (up to 12 months)

Body System[±]/Adverse Drug Reaction	XELJANZ 5mg BID (N=198)	XELJANZ 10mg BID (N=196)	Placebo (N=198)
Subjects with one or more ADR (%)	166 (83.8)	207 (100)	153 (77.3)
Blood and lymphatic system disorders	9 (4.5)	5 (2.6)	3 (1.5)
Anemia	8(4.0)	4 (2.0)	3 (1.5)
Gastrointestinal disorders	16 (8.1)	32 (16.3)	26 (13.1)
Diarrhea	3 (1.5)	9 (4.6)	5 (2.5)
Nausea	1 (0.5)	8 (4.1)	5 (2.5)
Abdominal pain	5 (2.5)	7 (3.6)	11 (5.6)
Vomiting	3 (1.5)	6 (3.1)	2 (1.0)
Dyspepsia	4 (2.0)	1 (0.5)	2 (1.0)
General disorders and administration	12 (6.1)	11 (5.6)	17 (8.6)

Body System[±]/Adverse Drug Reaction	XELJANZ 5mg BID (N=198)	XELJANZ 10mg BID (N=196)	Placebo (N=198)
site conditions			
Fatigue	8 (4.0)	4 (2.0)	11 (5.6)
Pyrexia	3 (1.5)	6 (3.1)	5 (2.5)
Infections and infestations	51 (25.8)	65 (33.2)	37 (18.7)
Nasopharyngitis	19 (9.6)	27 (13.8)	11 (5.6)
Herpes zoster	3 (1.5)	10 (5.1)	1 (0.5)
Influenza	4 (2.0)	7 (3.6)	7 (3.5)
Urinary tract infection	5 (2.5)	6 (3.1)	4 (2.0)
Bronchitis	5 (2.5)	6 (3.1)	3 (1.5)
Sinusitis	6 (3.0)	2 (1.0)	2 (1.0)
Pharyngitis	6 (3.0)	1 (0.5)	3 (1.5)
Gastroenteritis viral	0	3 (1.5)	2 (1.0)
Viral infection	2 (1.0)	1 (0.5)	1 (0.5)
Injury, poisoning and procedural complications	2 (1.0)	2 (1.0)	0
Ligament sprain	1 (0.5)	2 (1.0)	0
Investigations	19 (9.6)	38 (19.4)	7 (3.5)
Elevated cholesterol levels*	9 (4.5)	18 (9.2)	3 (1.5)
Blood creatine phosphokinase increased	6 (3.0)	13 (6.6)	4 (2.0)
Weight increased	3 (1.5)	4 (2.0)	0
Gamma glutamyltransferase increased,	1 (0.5)	3 (1.5)	0
Musculoskeletal and connective tissue disorders	19 (9.6)	19 (9.7)	25 (12.6)
Arthralgia	17 (8.6)	17 (8.7)	19 (9.6)
Musculoskeletal pain	1 (0.5)	2 (1.0)	5 (2.5)
Neoplasms benign, malignant and unspecified (including cysts and polyps)	0	2 (1.0)	1 (0.5)
Non-melanoma skin cancers	0	2 (1.0)	1 (0.5)
Nervous system disorders	18 (9.1)	7 (3.6)	12 (6.1)
Headache	17 (8.6)	6 (3.1)	12 (6.1)
Psychiatric	3 (1.5)	1 (0.5)	1 (0.5)
Insomnia	3 (1.5)	1 (0.5)	1 (0.5)
Respiratory	6 (3.0)	8 (4.1)	6 (3.0)
Cough	6 (3.0)	5 (2.6)	5 (2.5)
Dyspnea	0	2 (1.0)	1 (0.5)
Skin and Subcutaneous Tissue Disorders	7 (3.5)	12 (6.1)	17 (8.6)
Rash	6 (3.0)	11 (5.6)	8 (4.0)
Vascular disorders	4 (2.0)	4 (2.0)	1 (0.5)
Hypertension	4 (2.0)	4 (2.0)	1 (0.5)

* includes: hypercholesterolemia, hyperlipidemia, blood cholesterol increased, dyslipidemia, blood triglycerides increased, low density lipoprotein increased, low density lipoprotein abnormal, or lipids increased.

± The total number of subjects with adverse reactions and the total number of subjects with adverse reactions for each body system include all adverse drug reactions (those reported by ≥1% of subjects treated with XELJANZ and those reported by <1% of subjects treated with XELJANZ); the total also includes some subjects who reported more than one adverse drug reaction (which inflates the percentage).

Overall Infections Rheumatoid Arthritis

In the five controlled trials, during 0 to 3 months exposure, the overall frequency of infections was 20% in the 5 mg BID XELJANZ group, and 18% in the placebo group.

In the long-term extension trial, overall frequency of infections was 67.7% (39.63 events/100 patient-years) in all XELJANZ group; 65.5% of patients (33.22 events/100 patient-years) and 68.4% of patients (42.24 events/100 patient-years) in the 5 mg and 10 mg BID of tofacitinib, respectively.

The most commonly reported infections were upper respiratory tract infections, nasopharyngitis, bronchitis, herpes zoster, and urinary tract infections.

Psoriatic Arthritis

The incidence rates and types of overall infections in the two controlled Phase 3 PsA clinical studies were generally similar to those reported in RA clinical studies.

Ulcerative Colitis

In the randomised 8-week Phase 2/3 induction studies, the proportions of patients with infections were 21.1% (198 patients) in the XELJANZ 10 mg BID group compared to 15.2% (43 patients) in the placebo group. In the randomised 52-week Phase 3 maintenance study, the proportion of patients with infections were 35.9% (71 patients) in the 5 mg BID and 39.8% (78 patients) in the 10 mg BID XELJANZ groups, compared to 24.2% (48 patients) in the placebo group.

In the maintenance study, results suggested that the risk of opportunistic infection was possibly dose related: XELJANZ 10 mg BID (2.0%), XELJANZ 5 mg BID (1.0%), and placebo (0.5%). All opportunistic infections were herpes zoster infections. Herpes zoster was reported more frequently with XELJANZ 10 mg BID (5.1%), as compared to XELJANZ 5 mg BID (1.5%), or placebo (0.5%), indicating that the risk of herpes zoster is dose related.

In the entire treatment experience with XELJANZ, the most commonly reported infection was nasopharyngitis, occurring in 18.2% of patients (211 patients).

Serious Infections

Rheumatoid Arthritis

In the five controlled trials, during the 0 to 3 months exposure, serious infections were reported in 1 patient (0.6 events/100 patient-years) who received placebo and 8 patients (2.8 events/100 patient-years) who received 5 mg BID of XELJANZ.

During the 0 to 12 months exposure, the overall frequencies of serious infections were 2.4% (3.2 events/100 patient-years) for the 5 mg BID XELJANZ group.

In the long-term extension trial, the most common serious infections reported with XELJANZ included pneumonia, cellulitis, appendicitis, diverticulitis, gastroenteritis, urinary tract infection, and herpes zoster (see **WARNINGS AND PRECAUTIONS**).

Psoriatic Arthritis

The incidence rates and types of serious infections in the two controlled Phase 3 PsA clinical studies were generally similar to those reported in RA clinical studies.

Ulcerative Colitis

The incidence rates and types of serious infections in the UC clinical trials were generally similar to those reported in RA clinical trials with XELJANZ.

Patients treated with XELJANZ 10 mg BID had a higher rate of serious infections compared to those treated with 5 mg twice daily.

Tuberculosis

Cases of tuberculosis have been reported with treatment with XELJANZ.

Rheumatoid Arthritis

In the five controlled trials, during 0 to 3 months exposure, no cases of tuberculosis were reported in patients who received placebo or 5 mg BID of XELJANZ.

During the 0 to 12 months exposure, tuberculosis was reported in 0 patients who received 5 mg BID of XELJANZ.

In the long-term extension trial, adjudicated tuberculosis events were reported in 0.6% patients (0.15 events/100 patient-years) who received XELJANZ; 0.4% of patients (0.10 events/100 patient-years) and 0.6% of patients (0.17 events/100 patient-years) in the 5 mg and 10 mg BID of tofacitinib, respectively.

Cases of disseminated tuberculosis were also reported. The median XELJANZ exposure prior to diagnosis of tuberculosis was 10 months (range from 152 to 960 days) (see **WARNINGS AND PRECAUTIONS**).

Psoriatic Arthritis

The incidence rates of tuberculosis in the two controlled Phase 3 PsA clinical studies were generally similar to those reported in RA clinical studies.

Opportunistic Infections (excluding tuberculosis)

Rheumatoid Arthritis

In the five controlled trials, during 0 to 3 months exposure, opportunistic infections were reported in 0 patients who received placebo and 2 (0.2%) patients (0.7 events/100 patient-years) who received 5 mg BID of XELJANZ.

During the 0 to 12 months exposure, opportunistic infections were reported in 3 (0.3%) patients (0.3 events/100 patient-years) who received 5 mg BID of XELJANZ.

The median XELJANZ exposure prior to diagnosis of an opportunistic infection was 8 months (range from 41 to 698 days).

The similar frequency of opportunistic infections was observed in the long-term extension trial with XELJANZ treatment up to 114 months.

Psoriatic Arthritis

The incidence rates and types of opportunistic infections in the two controlled Phase 3 PsA clinical studies were generally similar to those reported in RA clinical studies.

Ulcerative Colitis

In the maintenance study, herpes zoster was reported more frequently with XELJANZ 10 mg BID (5.1%), as compared to XELJANZ 5 mg BID (1.5%), or placebo (0.5%), indicating that the risk of herpes zoster is dose related.

Also, opportunistic herpes zoster infections (including serious cases, such as, disseminated, meningoencephalitis, ophthalmologic) were reported in patients treated with XELJANZ 10 mg twice daily.

Malignancy (excluding non-melanoma skin cancer)

Rheumatoid Arthritis

In the five controlled trials, during the 0 to 3 months exposure, malignancies (excluding non-melanoma skin cancer) were reported in 0 patients who received placebo and 2 (0.2%) patients (0.7 events/100 patient-years) who received 5 mg BID of XELJANZ.

During the 0 to 12 months exposure, malignancies (excluding non-melanoma skin cancer) were reported in 5 (0.4%) patients (0.6 events/100 patient-years) who received 5 mg BID of XELJANZ.

In the long-term extension trial, overall frequency of malignancies (excluding non-melanoma skin cancer) was 3.1% (0.83 events/100 patient-years) in all XELJANZ-treated patients; 3.4% of patients (0.8 events/100 patient-years) and 3% of patients (0.84 events/100 patient-years) in the 5 mg and 10 mg BID of tofacitinib, respectively.

The most common types of malignancy (excluding non-melanoma skin cancer), including malignancies observed during the long-term extension, were lung and breast cancer, followed by gastric, colorectal, renal cell, prostate cancer, lymphoma and malignant melanoma (see **WARNINGS AND PRECAUTIONS**).

Psoriatic Arthritis

The incidence rates of malignancies (excluding NMSC) in the two controlled Phase 3 PsA clinical studies were generally similar to those reported in RA clinical studies.

Ulcerative Colitis

In the controlled clinical studies (up to 52-week treatment), no malignancies (excluding NMSC) were reported with XELJANZ.

In the long-term extension open-label study, malignancies (excluding NMSC) have been observed in patients treated with XELJANZ 10 mg BID, including solid cancers and lymphoma.

Non-Melanoma Skin Cancer

NMSC is a dose related adverse reaction, with a greater risk in patients treated with 10 mg BID of XELJANZ than in patients treated with 5 mg BID.

Rheumatoid Arthritis

In the five controlled trials, during the 0 to 3 months exposure, NMSC was reported in 1 (0.2%) patient (0.6 events/100 patient-years) who received placebo and 2 (0.2%) patients (0.7 events/100 patient-years) who received 5 mg BID of XELJANZ.

During the 0 to 12 months exposure, NMSC was reported in 3 (0.3%) patients (0.3 events/100 patient-years) who received 5 mg BID of XELJANZ.

In the long-term extension trial, overall frequency of NMSC was 2.6% (0.71 events/100 patient-years) in all XELJANZ-treated patients; 2.5% of patients (0.6 events/100 patient-years) and 2.6% of patients (0.75 events/100 patient-years) in the 5 mg and 10 mg BID of tofacitinib, respectively.

Psoriatic Arthritis

The incidence rates of NMSC in the two controlled Phase 3 PsA clinical studies were generally similar to those reported in RA clinical studies.

Less Common Clinical Trial Adverse Drug Reactions (<1%)

Rheumatoid Arthritis

Blood and Lymphatic System Disorders: neutropenia, leukopenia, lymphopenia

Cardiovascular: congestive heart failure, myocardial infarction

Gastrointestinal Disorders: abdominal pain

General Disorders and Administration Site Conditions: influenza

Hepatobiliary Disorders: hepatic steatosis

Infections and Infestations: sepsis, pneumonia bacterial, pneumonia pneumococcal, pyelonephritis, cellulitis, gastroenteritis viral, viral infection, herpes simplex, herpes zoster, tuberculosis of central nervous system, encephalitis, necrotising fasciitis, meningitis cryptococcal, disseminated tuberculosis, urosepsis, pneumocystis jiroveci pneumonia, staphylococcal bacteraemia, tuberculosis, arthritis bacterial, atypical mycobacterial infection, mycobacterium avium complex infection, cytomegalovirus infection, bacteraemia, diverticulitis

Injury, Poisoning and Procedural Complications: muscle strain, fall

Investigations: transaminases increased, blood creatinine increased, gamma glutamyltransferase increased, liver function test abnormal, weight increased, blood creatine phosphokinase increased, hepatic enzyme increased, low density lipoprotein increased, blood cholesterol increased

Metabolism and Nutrition Disorders: dehydration, dyslipidemia, hyperlipidemia

Musculoskeletal and Connective Tissue Disorders: tendonitis, joint swelling, musculoskeletal pain, ligament sprain

Neoplasm Benign, Malignant and Unspecified (Including Cysts and Polyps): non-melanoma skin cancers

Nervous System Disorders: paraesthesia

Psychiatric Disorders: insomnia

Respiratory, Thoracic and Mediastinal Disorders: sinus congestion, cough, dyspnoea

Skin and Subcutaneous Tissue Disorders: erythema, pruritus

Psoriatic Arthritis

The incidence rates of less common clinical trial adverse drug reactions (<1%) in the two controlled Phase 3 PsA clinical studies were generally similar to those reported in RA clinical studies.

Ulcerative Colitis

Blood and Lymphatic System Disorders: neutropenia, lymphopenia, leukopenia

Gastrointestinal Disorders: gastritis

General Disorders and Administration Site Conditions: oedema peripheral

Hepatobiliary Disorders: hepatic steatosis

Infections and Infestations: pneumonia, pyelonephritis, cellulitis, herpes simplex, tuberculosis, arthritis bacterial, cytomegalovirus infection, diverticulitis

Injury, Poisoning and Procedural Complications: muscle strain

Investigations: hepatic enzyme increased, transaminases increased, blood creatinine increased, liver function test abnormal, low density lipoprotein increased

Metabolism and Nutrition Disorders: dehydration

Musculoskeletal and Connective Tissue Disorders: tendonitis, joint swelling

Neoplasm Benign, Malignant and Unspecified (Including Cysts and Polyps): non-melanoma skin cancers, solid cancers, lymphomas

Nervous System Disorders: paraesthesia

Respiratory, Thoracic and Mediastinal Disorders: sinus congestion

Skin and Subcutaneous Tissue Disorders: erythema, pruritus

Abnormal Hematologic and Clinical Chemistry Findings

Laboratory Tests – Rheumatoid Arthritis and Ulcerative Colitis

Creatine Kinase

Treatment with XELJANZ was associated with increases in creatine kinase (CK). Maximum effects were generally observed within 6 months. Rhabdomyolysis was reported in one patient treated with XELJANZ.

CK levels should be checked in patients with symptoms of muscle weakness and/or muscle pain to evaluate for evidence of rhabdomyolysis (see **WARNINGS AND PRECAUTIONS**).

ECG Findings

In placebo-controlled Phase 2 clinical trials, steady-state treatment with 5-10 mg BID XELJANZ was associated with statistically significant 4-7 bpm decreases in heart rate and 4-10 ms increases in the PR interval compared with placebo (see **WARNINGS AND PRECAUTIONS** and **DRUG INTERACTIONS**).

Lipids

Treatment with XELJANZ was associated with dose related increases in lipid parameters.

Elevations in lipid parameters (total cholesterol, LDL cholesterol, HDL cholesterol, triglycerides) generally reached maximal effects at 6 weeks following initiation of XELJANZ in the controlled RA double-blind clinical trials. Changes in lipid parameters from baseline through the end of the study (6-12 months) in the controlled clinical studies in RA are summarized below:

- Mean LDL cholesterol increased by 14% in the XELJANZ 5 mg BID arm.
- Mean HDL cholesterol increased by 16% in the XELJANZ 5 mg BID arm.
- Mean LDL/HDL ratios were essentially unchanged in XELJANZ-treated patients.

In the five controlled RA clinical trials, 4.4% of patients treated with 5 mg BID, initiated lipid-lowering medication while on study.

In the RA long-term safety population, elevations in the lipid parameters remained consistent with what was seen in the controlled clinical studies.

Liver Enzyme Tests

Confirmed increases in liver enzymes $>3x$ upper limit of normal (ULN) were uncommonly observed. In those patients experiencing liver enzyme elevation, modification of treatment regimen, such as reduction in the dose of concomitant DMARD, interruption of XELJANZ, or reduction in XELJANZ dose, resulted in decrease or normalization of liver enzymes.

In the controlled portion of the RA Phase 3 monotherapy study (0-3 months), ALT elevations $>3x$ ULN were observed in 1.65% and 0.41% of patients receiving placebo and 5 mg BID, respectively. In this study, AST elevations $>3x$ ULN were observed in 1.65%, and 0.41% of patients receiving placebo and 5 mg BID, respectively.

In the controlled portion of the RA Phase 3 studies on background DMARDs (0-3 months), ALT elevations $>3x$ ULN were observed in 0.9% and 1.24% of patients receiving placebo and 5 mg BID, respectively. In these studies, AST elevations $>3x$ ULN were observed in 0.72% and 0.52% of patients receiving placebo and 5 mg BID, respectively.

In the RA long-term extension trial, ALT and AST elevations greater than $3x$ ULN were observed in 2.2% and 1.1% of all XELJANZ-treated patients, respectively. Overall, total bilirubin elevations greater than $2x$ ULN were observed in 3 (0.1%) patients. Increases to $\geq 5x$ and $\geq 10x$ ULN were observed for both ALT (0.5% and 0.2% of patients, respectively) and AST (0.3% and 0.1% of patients, respectively) in all patients treated with XELJANZ.

In RA patients taking 5 mg BID of XELJANZ, the ALT and AST elevations greater than $3x$ ULN were observed in 2.4% and 1.3% of patients, respectively. There was no subject who had the total bilirubin elevations greater than $2x$ ULN. Increases to $\geq 5x$ and $\geq 10x$ ULN were observed for both ALT (0.4% and 0.1% of patients, respectively) and AST (0.2% and 0% of patients, respectively).

In RA patients taking 10 mg twice daily of tofacitinib, the ALT and AST elevations greater than $3x$ ULN were observed in 2.1% and 1.1% of patients, respectively. The total bilirubin elevations greater than $2x$ ULN were observed in 3 (0.1%) patients. Increases to $\geq 5x$ and $\geq 10x$ ULN were observed for both ALT (0.5% and 0.2% of patients, respectively) and AST (0.3% and 0.1% of patients, respectively).

Two patients treated with 10 mg BID of tofacitinib in the RA long-term extension trial were assessed as probable DILI by the adjudication committee. One of the two patients had other possible causes of alcohol intake and methotrexate.

In the clinical studies in UC, changes in liver enzyme tests observed with XELJANZ 5 mg BID treatment were similar to the changes observed in clinical studies in RA.

In UC patients, XELJANZ treatment with 5 and 10 mg BID was also associated with an increased incidence of liver enzyme elevation compared to placebo, with a trend for higher incidence with the 10 mg BID as compared to the 5 mg BID dose.

One patient with XELJANZ 10 mg BID in the maintenance UC study experienced an increase in liver enzymes which decreased upon discontinuation of treatment. The case was adjudicated as possible DILI, while noting ultrasound findings of fatty liver.

Lymphocytes

In the five controlled RA clinical trials, confirmed decreases in absolute lymphocyte counts below 500 cells/mm³ occurred in 0.2% of patients for the 5 mg BID XELJANZ group during 12 months of exposure.

Confirmed lymphocyte counts less than 500 cells/mm³ were associated with an increased incidence of treated and serious infections (see **WARNINGS AND PRECAUTIONS**).

In the RA long-term extension trial, cases of lymphopenia have been reported in 181 (4.0%) patients (1.11 events/100 patient-years) treated with XELJANZ; 4.5% of patients (1.07 events/100 patient-years) and 3.9% of patients (1.12 events/100 patient-years) in the 5 mg and 10 mg BID of tofacitinib, respectively. Confirmed decreased in absolute lymphocyte counts below 500 cells/mm³ occurred in 1.3% of all XELJANZ-treated patients; 1.1% of patients for the 5 mg BID XELJANZ group, and 1.4% of patients for the 10 mg BID tofacitinib group.

In the 52-week maintenance study in UC, a single absolute lymphocyte count below 500 cells/mm³ was reported in 2.6% (n=5) of patients treated with 10 mg BID, and was not reported in patients treated with 5 mg BID or placebo. No patients in any treatment group had confirmation of a lymphocyte count below 500 cells/mm³ based on two sequential tests.

Neutrophils

In the controlled RA clinical studies, confirmed decreases in ANC below 1000/mm³ occurred in 0.08% of patients in the 5 mg BID XELJANZ group during 12 months of exposure. There were no confirmed decreases in ANC below 500/mm³ observed in any treatment group.

There was no clear relationship between neutropenia and the occurrence of serious infections.

In the long-term extension trial, cases of neutropenia have been reported in 86 (1.9%) patients (0.52 events/100 patient-years) treated with XELJANZ; 4.0% of patients (0.97 events/100 patient-years) and 1.2% of patients (0.35 events/100 patient-years) in the 5 mg and 10 mg BID of tofacitinib, respectively. Confirmed decreased in ANC below 1000 cells/mm³ occurred in 0.2% in all XELJANZ-treated patients; 0.4% of patients for the 5 mg BID XELJANZ group, and 0.1% of patients for the 10 mg BID tofacitinib group.

In the clinical studies in UC, changes in neutrophils observed with XELJANZ treatment were similar to the changes observed in clinical studies in RA.

Serum Creatinine

In the controlled RA clinical trials, dose-related elevations in serum creatinine were observed with XELJANZ treatment. The mean increase in serum creatinine was <0.1 mg/dL in the 12-month pooled safety analysis; however, with increasing duration of exposure in the long-term extension trial, up to 6.9% of patients were discontinued from XELJANZ treatment due to the protocol-specified discontinuation criterion of an increase in creatinine by more than 50% of baseline. The clinical significance of the observed serum creatinine elevations is unknown.

In the UC studies, an increase of more than 50% in serum creatinine was reported in 1.6% of patients predominantly treated with XELJANZ 5 mg BID, and 3.4% of those predominantly treated with XELJANZ 10 mg BID.

Laboratory Tests – Psoriatic Arthritis

In the controlled clinical trials in PsA, changes in hematologic and clinical chemistry findings observed with XELJANZ treatment were similar to the changes observed in clinical trials in RA.

Post-Marketing Adverse Drug Reactions

Because these reactions are reported voluntarily from a population of uncertain size, it is generally not possible to reliably estimate their frequency or establish a causal relationship to drug exposure.

Immune system disorders: drug hypersensitivity reactions including angioedema and urticaria (see **CONTRAINDICATIONS** and **WARNINGS AND PRECAUTIONS**)

Serious infections: viral reactivation (hepatitis B reactivation) (see **WARNINGS AND PRECAUTIONS**)

Vascular disorders: Thrombosis (deep vein thrombosis, pulmonary embolism, and arterial thrombosis) (see **WARNINGS AND PRECAUTIONS**)

DRUG INTERACTIONS

Overview

In vitro studies indicate that tofacitinib does not significantly inhibit the activity of the major human drug metabolizing CYPs (CYP1A2, CYP2B6, CYP2C8, CYP2C9, CYP2C19, CYP2D6, and CYP3A4) at concentrations exceeding 80 times the steady state C_{max} of a 5 and 10 mg BID dose in patients treated with tofacitinib. In vitro studies also indicated a low risk of induction of CYP3A4 (2-fold mRNA at 6.25 μ M), CYP2B6 (2-fold mRNA at 12.5 μ M), and CYP1A2 (no enzyme changes) at clinically relevant concentrations (total C_{max} of 0.186 μ M).

In vitro, tofacitinib is a substrate for multidrug resistance (MDR) 1, but not for breast cancer resistance protein (BCRP), organic anion transporting polypeptide (OATP) 1B1/1B3, or organic cationic transporter (OCT) 1/2. In vitro data indicate that the potential for tofacitinib to inhibit transporters such as P-glycoprotein, MDR1, organic anion transporter (OAT) P1B1/1B3, OCT2,

OAT1/3, cationic transporters or multidrug resistance-associated protein (MRP) at therapeutic concentrations is also low.

Tofacitinib exposure is increased when XELJANZ is coadministered with potent CYP3A4 inhibitors (e.g., ketoconazole) or when administration of one or more concomitant medications results in both moderate inhibition of CYP3A4 and potent inhibition of CYP2C19 (e.g., fluconazole). Tofacitinib exposure is decreased when XELJANZ is coadministered with potent CYP3A4 inducers (e.g. rifampin). Inhibitors of CYP2C19 or P-glycoprotein are unlikely to alter the PK of tofacitinib.

The in vitro results were confirmed by a human drug interaction study showing no changes in the PK of midazolam, a highly sensitive CYP3A4 substrate, when coadministered with XELJANZ.

In vitro studies indicate that tofacitinib does not significantly inhibit the activity of the major human drug-metabolizing uridine 5'-diphospho-glucuronosyltransferases (UGTs) [UGT1A1, UGT1A4, UGT1A6, UGT1A9, and UGT2B7] at concentrations exceeding 250 times the steady state C_{max} of a 5 and 10 mg twice daily dose in RA, PsA and UC patients.

The oral clearance of tofacitinib does not vary with time, indicating that tofacitinib does not normalize CYP enzyme activity in patients. Therefore, coadministration with XELJANZ/XELJANZ XR is not expected to result in clinically relevant increases in the metabolism of CYP substrates.

Drug-Drug Interactions

Table 4: Summary of Drug-Drug Interactions

Drug	Reference	Effect	Clinical Comment
Methotrexate	CT	Coadministration with methotrexate (15-25 mg MTX once weekly) had no effect on the PK of tofacitinib and decreased methotrexate AUC (area under the curve) and C_{max} by 10% and 13% respectively.	No dose adjustment is required for either drug.

Drug	Reference	Effect	Clinical Comment
Ketoconazole	CT	Coadministration of ketoconazole, a strong CYP3A4 inhibitor, with a single dose of XELJANZ increased the AUC and C _{max} of tofacitinib by 103% and 16%, respectively	<p>XELJANZ XR is not recommended in patients coadministered with strong inhibitors of CYP3A4.</p> <p>The recommended dose is half the daily dose indicated for patients not receiving strong CYP3A4 inhibitors concomitantly, i.e., in patients already taking:</p> <p>XELJANZ 10 mg twice daily, reduce the dose to XELJANZ 5 mg twice daily or</p> <p>XELJANZ 5 mg twice daily, reduce the dose to XELJANZ 5 mg once daily.</p>
Fluconazole	CT	Coadministration of fluconazole, a moderate inhibitor of CYP3A4 and a strong inhibitor of CYP2C19, increased the AUC and C _{max} of tofacitinib by 79% and 27%, respectively	<p>XELJANZ XR is not recommended in patients coadministered with medications that result in moderate inhibition of CYP3A4 and potent inhibition of CYP2C19.</p> <p>The recommended dose is half the daily dose indicated for patients not receiving concomitant medications that result in moderate inhibition of CYP3A4 and potent inhibition of CYP2C19, i.e., in patients already taking:</p> <p>XELJANZ 10 mg twice daily, reduce the dose to XELJANZ 5 mg twice daily or</p> <p>XELJANZ 5 mg twice daily, reduce the dose to XELJANZ 5 mg once daily.</p>
Tacrolimus and Cyclosporine	CT	<p>Coadministration of tacrolimus, a mild inhibitor of CYP3A4, increased the AUC of tofacitinib by 21% and decreased the C_{max} of tofacitinib by 9%.</p> <p>Coadministration of cyclosporine, a moderate inhibitor of CYP3A4, increased the AUC of tofacitinib by 73% and decreased C_{max} of tofacitinib by 17%.</p>	<p>There is a risk of added immunosuppression when XELJANZ/XELJANZ XR is co-administered with potent immunosuppressive drugs (e.g: tacrolimus, cyclosporine, azathioprine). The combined use with these potent immunosuppressives has not been studied in patients and is not recommended.</p>

Drug	Reference	Effect	Clinical Comment
Rifampin	CT	Coadministration of rifampin, a strong CYP3A4 inducer, decreased the AUC and C _{max} of tofacitinib by 84% and 74%, respectively	Coadministration of XELJANZ/XELJANZ XR with potent inducers of CYP3A4 may result in loss of or reduced clinical response /efficacy.
Midazolam	CT	Coadministration of XELJANZ with midazolam, a highly sensitive CYP3A4 substrate, had no effect on midazolam PK	No dosage adjustment is required for CYP3A4 substrates such as midazolam.
Oral contraceptives (Ethinyl Estradiol and Levonorgestrel)	CT	Coadministration of XELJANZ with oral contraceptives had no effect on the PK of either oral contraceptive in healthy females	No dose adjustment is required for either oral contraceptives (ethinyl estradiol and levonorgestrel).
Metformin	CT	Coadministration of XELJANZ with metformin, a substrate of Organic Cationic Transporter and Multidrug and Toxic Compound Extrusion, had no effect on the PK of metformin	No dosage adjustment is required for metformin.

Legend: C = Case Study; CT = Clinical Trial; T = Theoretical

The impact of extrinsic factors on tofacitinib pharmacokinetics is summarized in Figure 1 and 2 with dosage adjustment recommendations.

Figure 1: Impact of Co-administered of drugs on Pharmacokinetics Tofacitinib

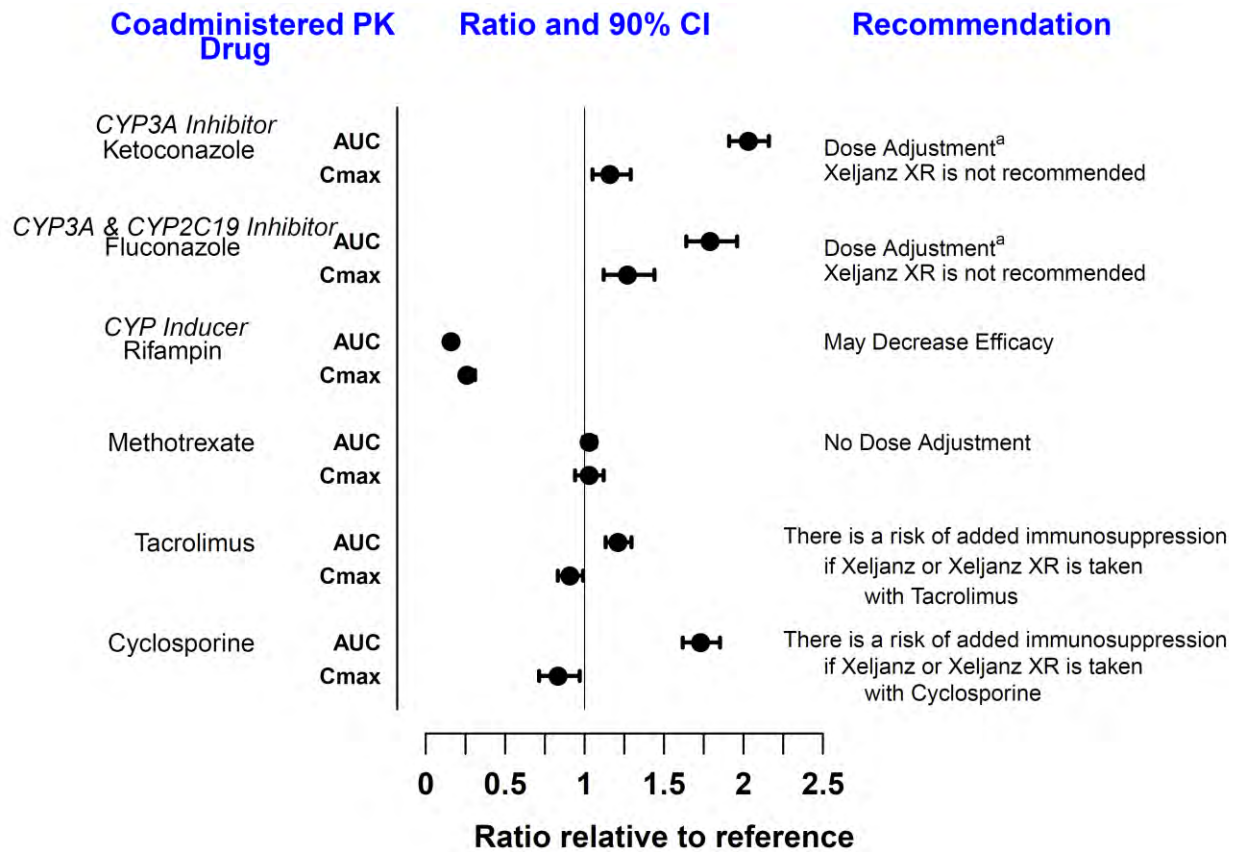

Note: Reference group is administration of tofacitinib alone; PK=Pharmacokinetics; CI=Confidence Interval

^a In RA patients the recommended dose is XELJANZ 5 mg once daily. In UC patients receiving 10 mg twice daily, XELJANZ dosage should be reduced to 5 mg twice daily, and in UC patients receiving 5 mg twice daily, XELJANZ dosage should be reduced to 5 mg once daily.

Figure 2: Impact of Tofacitinib on Pharmacokinetics of Co-administered Drugs

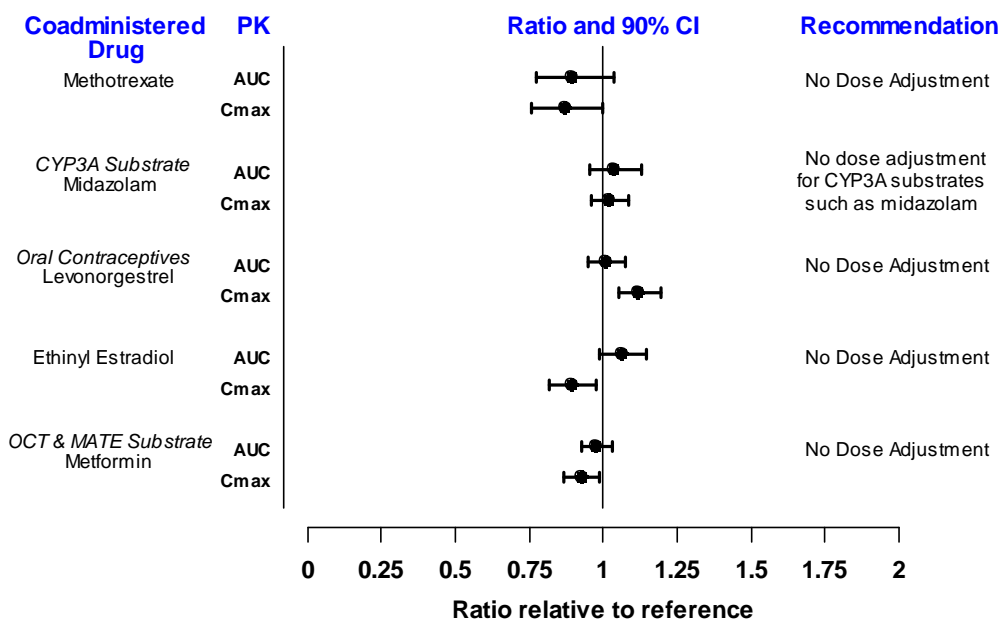

Note: Reference group is administration of concomitant medication alone; OCT = Organic Cationic Transporter; MATE = Multidrug and Toxic Compound Extrusion; PK=Pharmacokinetics; CI=Confidence Interval

Drugs that Decrease Heart Rate and/or Prolong the PR Interval

XELJANZ resulted in a decrease in heart rate and an increase in the PR interval (see **WARNINGS AND PRECAUTIONS** and **ADVERSE REACTIONS**). Caution should be observed if XELJANZ/XELJANZ XR is used concomitantly with other drugs that lower heart rate and/or prolong the PR interval, such as antiarrhythmics, beta blockers, alpha₂ adrenoceptor agonists, non-dihydropyridine calcium channel blockers, digitalis glycosides, cholinesterase inhibitors, sphingosine-1 phosphate receptor modulators, and some HIV protease inhibitors.

Combination with other therapies

XELJANZ/XELJANZ XR has not been studied and is not indicated to be used in combination with biologics such as TNF antagonists, interleukin (IL)-1R antagonists, IL-6R antagonists, IL-17 antagonists, IL-12/IL-23 antagonists, anti-CD20 monoclonal antibodies, anti-integrins, selective co-stimulation modulators, and potent immunosuppressants such as azathioprine, 6-mercaptopurine, cyclosporine, and tacrolimus because of the possibility of increased immunosuppression and increased risk of infection.

The use of XELJANZ/XELJANZ XR in combination with phosphodiesterase 4 inhibitors has not been studied in XELJANZ clinical trials.

Drug-Food Interactions

Grapefruit juice affects CYP450 3A-mediated metabolism and concomitant administration with XELJANZ/XELJANZ XR should be avoided.

Drug-Laboratory Interactions

Interactions with laboratory tests have not been established.

Drug-Herb Interactions

St John's Wort is a CYP3A4 inducer and co-administration with XELJANZ/XELJANZ XR may result in loss of or reduced clinical response.

Drug-Lifestyle Interactions

No formal studies have been conducted on the effects on the ability to drive and use machines.

DOSAGE AND ADMINISTRATION

Dosing Considerations

There is a risk of added immunosuppression when XELJANZ/XELJANZ XR is coadministered with potent immunosuppressive drugs (e.g. azathioprine, tacrolimus, cyclosporine). Combined use of XELJANZ/XELJANZ XR with potent immunosuppressants or biologic DMARDS (tumor necrosis factor (TNF) antagonists, interleukin 1 receptor (IL-1R) antagonists, IL-6R antagonists, anti-CD20 monoclonal antibodies, IL-17 antagonists, IL-12/IL-23 antagonists and selective co-stimulation modulators) has not been studied in RA, PsA and UC patients and its use should be avoided.

Recommended Dose and Dosage Adjustment

Rheumatoid Arthritis XELJANZ/XELJANZ XR Posology

Adults: XELJANZ/XELJANZ XR is to be used in combination with methotrexate.

XELJANZ/XELJANZ XR, monotherapy may be considered in cases of intolerance to methotrexate.

The recommended dose of XELJANZ is 5 mg administered twice daily. The recommended dose of XELJANZ XR is 11 mg once daily

XELJANZ/XELJANZ XR is given orally with or without food.

Swallow XELJANZ XR tablets whole and intact. Do not crush, split, or chew.

Switching between XELJANZ Tablets and XELJANZ XR Tablets: Where appropriate, patients treated with XELJANZ 5 mg twice daily may be switched to XELJANZ XR 11 mg once daily the day following the last dose of XELJANZ 5 mg.

Where appropriate, patients treated with XELJANZ XR 11 mg once daily may be switched to XELJANZ 5 mg twice daily 24 hours following the last dose of XELJANZ XR 11 mg.

Patients treated with XELJANZ XR 11 mg once daily who require a dose reduction due to renal or hepatic impairment or drug interactions may be switched to XELJANZ 5 mg once daily,

24 hours following the last dose of XELJANZ XR 11 mg once daily (see **WARNINGS AND PRECAUTIONS** and **DRUG INTERACTIONS**).

Psoriatic Arthritis XELJANZ Posology

Adults: The recommended dose of XELJANZ is 5 mg administered twice daily in combination with MTX or another csDMARD.

Ulcerative Colitis XELJANZ Posology

Adults: The recommended dose is 10 mg given orally twice daily for induction for at least 8 weeks and 5 mg given twice daily for maintenance.

Depending on therapeutic response; 10 mg twice daily may also be used for maintenance in some patients. However, the lowest effective dose possible should be used for maintenance therapy to minimize adverse effects (see **WARNINGS AND PRECAUTIONS**).

XELJANZ induction therapy should be discontinued in patients who show no evidence of adequate therapeutic benefit by Week 16.

In patients who have responded to treatment with XELJANZ, corticosteroids may be cautiously reduced and/or discontinued in accordance with standard of care.

Dose Modification due to Serious Infections and Cytopenias (see Tables 5-7 below)

- It is recommended that XELJANZ/XELJANZ XR not be initiated in patients with an absolute neutrophil count (ANC) less than 1000/mm³, hemoglobin (Hgb) levels <9 g/d, or with a lymphocyte count less than 500 cells/mm³ (see **WARNINGS AND PRECAUTIONS**).
- Dose interruption is recommended for management of lymphopenia, neutropenia and anemia (see **WARNINGS AND PRECAUTIONS** and **ADVERSE REACTIONS**).
- Avoid use of XELJANZ/XELJANZ XR if a patient develops a serious infection until the infections is controlled.

Table 5: Dose Adjustments for Neutropenia

Low ANC	
Lab Value (cells/mm³)	Recommendation
ANC >1000	Maintain dose
ANC 500-1000	For persistent decreases in this range, interrupt or reduce administration with XELJANZ/XELJANZ XR until ANC is >1000 cells/mm ³ <ul style="list-style-type: none"> For patients receiving XELJANZ 5 mg twice daily, interrupt XELJANZ dosing. When ANC is >1000, resume XELJANZ 5 mg twice daily. RA patients: <ul style="list-style-type: none"> When ANC is >1000 cells/mm³, resume XELJANZ XR 11 mg once daily. UC patients: <ul style="list-style-type: none"> For patients receiving XELJANZ 10 mg twice daily, reduce dose to XELJANZ 5 mg twice daily. When ANC is >1000, increase to XELJANZ 10 mg twice daily based on clinical response.
ANC <500 (Confirmed by repeat testing)	Discontinue treatment with XELJANZ/XELJANZ XR

Table 6: Dose Adjustments for Anemia

Low Hemoglobin Value	
Lab Value (g/dL)	Recommendation
<2 g/dL decrease and ≥9.0 g/dL	Maintain dose
≥2 g/dL decrease or <8.0 g/dL (Confirmed by repeat testing)	Interrupt the administration of XELJANZ/XELJANZ XR until hemoglobin values have normalized

Table 7: Dose Adjustments for Lymphopenia Low Lymphocyte Count

Low Lymphocyte Count	
Lab Value (cells/mm³)	Recommendation
Lymphocyte count greater than or equal to 500	Maintain dose
Lymphocyte count less than 500 (Confirmed by repeat testing)	Discontinue XELJANZ/XELJANZ XR

Dose Modification in Patients with Renal or Hepatic Impairment**XELJANZ**

- XELJANZ is contraindicated in patients with severe hepatic impairment
- In patients with moderate (CL_{cr} ≥30 and <60 mL/min) or severe (CL_{cr} ≥15 and <30 mL/min) renal insufficiency (including patients with ESRD but not limited to those undergoing hemodialysis):
 - The recommended dose is XELJANZ 5 mg once daily when the indicated dose in the presence of normal renal function is XELJANZ 5 mg twice daily.
 - The recommended dose is XELJANZ 5 mg twice daily when the indicated dose in the presence of normal renal function is XELJANZ 10 mg twice daily.
 - Use XELJANZ with caution in this patient population.

- For patients undergoing hemodialysis, dose should be administered after the dialysis session on dialysis days. If a dose was taken before the dialysis procedure, supplemental doses are not recommended in patients after dialysis.
- Patients with severe renal insufficiency should remain on a reduced dose even after hemodialysis.
- In patients with moderate hepatic impairment:
 - The recommended dose is XELJANZ 5 mg once daily when the indicated dose in the presence of normal hepatic function is XELJANZ 5 mg twice daily.
 - The recommended dose is XELJANZ 5 mg twice daily when the indicated dose in the presence of normal hepatic function is XELJANZ 10 mg twice daily.
 - Use XELJANZ with caution in this patient population.

XELJANZ XR

- XELJANZ XR is contraindicated in patients with severe hepatic impairment and should not be used in patients with moderate hepatic impairment.
- XELJANZ XR is not recommended in patients with moderate ($CL_{Cr} \geq 30$ and < 60 mL/min), or severe ($CL_{Cr} \geq 15$ and < 30 mL/min) renal insufficiency (including patients with ESRD but not limited to those undergoing hemodialysis).

In patients with moderate hepatic impairment or moderate to severe renal insufficiency, XELJANZ 5 mg once daily may be considered.

Dose Modification Due to Drug Interactions

Coadministration of potent inducers of CYP3A4 (e.g. rifampin) with XELJANZ/XELJANZ XR may result in loss of efficacy or reduced clinical response to XELJANZ/XELJANZ XR. Coadministration of potent inducers of CYP3A4 with XELJANZ/XELJANZ XR is not recommended.

XELJANZ

- In patients receiving potent inhibitors of Cytochrome P450 3A4 (CYP3A4) (e.g. ketoconazole) or one or more concomitant medications that result in both moderate inhibition of CYP3A4 and potent inhibition of CYP2C19 (e.g. fluconazole):
 - Reduce XELJANZ dose to 5 mg twice daily in patients taking 10 mg twice daily.
 - Reduce XELJANZ dose to 5 mg once daily in patients taking 5 mg twice daily.

XELJANZ XR

- XELJANZ XR is not recommended in patients:
 - Receiving potent inhibitors of Cytochrome P450 3A4 (CYP3A4) (e.g. ketoconazole).
 - Receiving one or more concomitant medications that result in both moderate inhibition of CYP3A4 and potent inhibition of CYP2C19 (e.g. fluconazole).

In patients with dose modifications due to drug interactions, XELJANZ 5 mg once daily may be considered.

Special Populations

Geriatrics (>65 years)

No dosage adjustment is required in patients aged 65 years and older (see **WARNINGS AND PRECAUTIONS** and **ACTION AND CLINICAL PHARMACOLOGY**).

Pediatrics (<18 years of age)

The safety and efficacy of XELJANZ/XELJANZ XR in children aged from neonates to less than 18 years of age has not yet been established. Therefore XELJANZ/XELJANZ XR should not be used in this patient population (see **WARNINGS AND PRECAUTIONS** and **ACTION AND CLINICAL PHARMACOLOGY**).

Missed Dose

For a missed dose, resume at the next scheduled dose.

OVERDOSAGE

There is no experience with overdose of XELJANZ/XELJANZ XR (tofacitinib). There is no specific antidote for overdose with XELJANZ/XELJANZ XR. Treatment should be symptomatic and supportive. In case of an overdose, it is recommended that the patient be monitored for signs and symptoms of adverse reactions. Patients who develop adverse reactions should receive appropriate treatment.

Pharmacokinetic data up to and including a single dose of 100 mg in healthy volunteers indicates that more than 95% of the administered dose is expected to be eliminated within 24 hours.

For management of a suspected drug overdose, contact your regional Poison Control Centre.

ACTION AND CLINICAL PHARMACOLOGY

Mechanism of Action

Tofacitinib is a potent, selective inhibitor of the JAK family of kinases with a high degree of selectivity against other kinases in the human genome. In kinase assays, tofacitinib, inhibits JAK1, JAK2, JAK3, and to a lesser extent TyK2. In cellular settings where JAK kinases signal in pairs, tofacitinib preferentially inhibits signaling by heterodimeric receptors associated with JAK3 and/or JAK1 with functional selectivity over receptors that signal via pairs of JAK2. Inhibition of JAK1 and JAK3 by tofacitinib blocks signaling through the common gamma chain-containing receptors for several cytokines, including IL-2, -4, -7, -9, -15, and -21. These cytokines are integral to lymphocyte activation, proliferation, and function and inhibition of their signaling may thus result in modulation of multiple aspects of the immune response. In addition, inhibition of JAK1 will result in attenuation of signaling by additional pro-inflammatory cytokines, such as IL-6 and Type I interferons. At higher exposures, inhibition of erythropoietin signaling could occur via inhibition of JAK2 signaling.

Pharmacodynamics

In patients with RA, treatment with XELJANZ (tofacitinib) was associated with dose-dependent reductions of circulating CD16/56+ natural killer cells, with estimated maximum reductions occurring at approximately 8-10 weeks after initiation of therapy. These changes generally resolved within 2-6 weeks after discontinuation of treatment. Treatment with XELJANZ was associated with dose-dependent increases in B cell counts. Changes in circulating T-lymphocyte counts and T-lymphocyte subsets were small and inconsistent. The clinical significance of these changes is unknown.

Changes in total serum IgG, M, and A levels over 6-month dosing of patients with RA were small, not dose-dependent and similar to those seen on placebo.

After treatment with XELJANZ in patients with RA, rapid decreases in serum C-reactive protein (CRP) were observed and maintained throughout dosing. Changes in CRP observed with XELJANZ treatment do not reverse fully within 2 weeks after discontinuation, indicating a longer duration of pharmacodynamic activity compared to the half-life.

Similar changes in T cells, B cells and serum CRP have been observed in patients with active PsA, although reversibility was not assessed. Total serum immunoglobulins were not assessed in patients with active PsA.

Patients with UC were not studied.

Pharmacokinetics (PK)

XELJANZ

Following oral administration of XELJANZ, the PK profile of XELJANZ is characterized by rapid absorption (peak plasma concentrations are reached within 0.5-1 hour), rapid elimination (half-life of ~3 hours) and dose-proportional increases in systemic exposure in the therapeutic dose range. Steady state concentrations are achieved in 24-48 hours with negligible accumulation after BID administration.

A geometric mean accumulation ratio (Rac) of 1.12 following BID dosing indicates little difference between single dose and steady state concentrations as well as the predictability of steady state PK from single dose data. The dose-AUC relationship was adequately described by a linear model fit to log-both sides transformed data while the dose-C_{max} relationship were best described by a nonlinear sigmoidal, hyperbolic model fit to log-transformed C_{max} data. Although the nonlinear model provided better description of the dose-C_{max} relationship relative to a linear model, when compared to 5 mg, the mean model predicted relative changes in dose-normalized C_{max} were approximately +7% for 10 mg, +2% for 30 mg, and -10% for 50 mg doses. These small changes from linearity support the conclusion that XELJANZ C_{max} is approximately dose proportional at least up to 5 times the 10 mg dose.

XELJANZ XR

Following oral administration of XELJANZ XR, peak plasma tofacitinib concentrations are reached at 4 hours and the half-life is ~6 hours. Steady state concentrations are achieved within 48 hours with negligible accumulation (accumulation ratio: 1.12) after once daily (QD) administration. At steady state, C_{min} for XELJANZ XR 11 mg QD is approximately 29% lower

and C_{trough} is approximately 26% lower compared to XELJANZ 5 mg BID. Area under the curve (AUC) and C_{max} of tofacitinib for XELJANZ XR 11 mg administered once daily are equivalent to those of XELJANZ 5 mg administered twice daily.

Pharmacokinetics in Patients with Moderately to Severely Active UC

Population PK analysis in UC patients indicated that PK characteristics were similar to that of RA patients. There were no clinically relevant differences in tofacitinib exposure (AUC), based on age, weight, gender and race, after accounting for differences in renal function (i.e., creatinine clearance) between patients. The between-subject variability (% coefficient of variation) in AUC of tofacitinib is estimated to be approximately 23% to 25% in UC patients.

Absorption:

XELJANZ

Tofacitinib is well-absorbed, with an absolute oral bioavailability of 74% following administration of XELJANZ. Coadministration of XELJANZ with a high-fat meal resulted in no changes in AUC while C_{max} was reduced by 32%. In clinical trials, XELJANZ was administered without regard to meal.

XELJANZ XR

Coadministration of XELJANZ XR with a high-fat meal resulted in no changes in AUC while C_{max} was increased by 27% and T_{max} was extended by approximately 1 hour.

Distribution:

After intravenous administration, the volume of distribution is 87 L. The protein binding of tofacitinib is ~40%. Tofacitinib binds predominantly to albumin and does not appear to bind to α 1-acid glycoprotein. Tofacitinib distributes equally between red blood cells and plasma.

Metabolism:

Clearance mechanisms for tofacitinib are approximately 70% hepatic metabolism and 30% renal excretion of the parent drug. The metabolism of tofacitinib is primarily mediated by CYP3A4 with minor contribution from CYP2C19. In a human radiolabeled study, more than 65% of the total circulating radioactivity was accounted for by unchanged tofacitinib, with the remaining 35% attributed to 8 metabolites, each accounting for less than 8% of total radioactivity. The pharmacologic activity of tofacitinib is attributed to the parent molecule.

Excretion:

Approximately 94% of a radioactive dose of XELJANZ was recovered from the urine (80%) and feces (14%), with the majority of excreted radioactivity recovered within 24 hours after dosing.

Table 8: Summary of Tofacitinib Pharmacokinetic Parameters after Repeated Oral Administration of XELJANZ 10 mg BID or Single IV Administration in Humans

	Oral Administration			IV Administration	
	C_{max} (ng/mL)	$t_{1/2}$ (h)	AUC _{0-12hrs} (ng·h/mL)	Clearance (L/h)	Volume of distribution (L)
Healthy Volunteers	79.4	3.0	311	25	87

	Oral Administration			IV Administration	
	C _{max} (ng/mL)	t _{1/2} (h)	AUC _{0-12hrs} (ng·h/mL)	Clearance (L/h)	Volume of distribution (L)
RA Patients	116	3.62	507	N/A (no IV data)	N/A (no IV data)
PsA Patients	88.9	3.74	436	N/A (no IV data)	N/A (no IV data)
UC Patients	91	3.05	404	N/A (no IV data)	N/A (no IV data)

N/A = Not available; C_{max} = maximum plasma concentration; t_{1/2} = terminal elimination half-life; AUC₀₋₁₂ = area under the plasma concentration-time curve from time 0 to 12 hours post dose; CL = total systemic clearance; V_{ss} = volume of distribution at steady state.

Table 9: Summary of Tofacitinib Pharmacokinetic Parameters after Repeated Oral Administration of XELJANZ XR 11 mg QD in Humans

	C _{max} (ng/mL)	t _{1/2} (h)	AUC _{0-24hrs} (ng·h/mL)	Tmax (h)
Healthy Volunteers	38.23	5.89	269	4.0

C_{max} = maximum plasma concentration; t_{1/2} = terminal elimination half-life; AUC₀₋₂₄ = area under the plasma concentration-time curve from time 0 to 24 hours post dose.

Special Populations and Conditions

Rheumatoid Arthritis and Ulcerative Colitis

Pediatrics (<18 years of age): The pharmacokinetics, safety and effectiveness of tofacitinib in pediatric patients have not been established; therefore, XELJANZ/XELJANZ XR should not be used in this patient population. Pharmacokinetic of tofacitinib was characterized in an open-label, non-randomized, multi-center, Phase 1 study conducted in pediatric patients (aged from 2 to less than 18 years) with juvenile idiopathic arthritis. A total of 26 patients were enrolled in this study and treated at dosing regimens based on the children's age and body weight. The study consisted of 3 cohorts based on subject age with at least 8 subjects per cohort. Based on limited data, the PK profile of tofacitinib appears to be characterized by a rapid absorption (peak plasma concentrations were reached within 0.5-1 hour) and a rapid elimination. The average half-lives for tofacitinib were approximately 2.6h, 1.9h, and 1.8h for the Cohorts 1 (12 to <18 years), 2 (6 to <12 years) and 3 (2 to <6 years), respectively, with individual values ranging from 1.4 to 3.1h across all cohorts.

Geriatrics (>65 years of age): Population PK analysis in RA patients indicated that elderly patients 80 years of age were estimated to have <5% higher XELJANZ AUC relative to the mean age of 55 years. Of the 3315 patients who enrolled in studies I to V, a total of 505 (15%) RA patients were 65 years of age and older, including 71 (2%) patients 75 years and older. The frequency of serious infection among XELJANZ treated subjects 65 years of age and older was higher than those under the age of 65.

There were not enough elderly patients treated with XELJANZ (n=77) in the UC program to adequately study the effects of XELJANZ in this population. As there is a higher incidence of infections in the elderly population in general, caution should be used when treating the elderly (see **WARNINGS AND PRECAUTIONS**).

Gender: Based on population PK analysis, female RA patients were estimated to have 7% lower XELJANZ AUC compared to male RA patients. Female UC patients were estimated to have 15.2% higher XELJANZ AUC compared to male UC patients.

Race: In RA patients, no major differences (<5%) were estimated in XELJANZ AUC between White, Black and Asian RA patients by population PK analysis. In UC patients, population PK analysis indicated that Asian patients had 7.3% higher XELJANZ AUC compared to non-Asian patients. There was a higher incidence of adverse events in Asian patients. Therefore, XELJANZ/XELJANZ XR should be used with caution in Asian patients (see **WARNINGS AND PRECAUTIONS**).

Body Weight: Population PK analysis in RA patients indicated that systemic exposure (AUC) of XELJANZ in the extremes of body weight (40 kg, 140 kg) were similar to that of a 70 kg patient. An approximately linear relationship between body weight and volume of distribution was observed, resulting in higher peak (C_{max}) and lower trough (C_{min}) concentrations in lighter patients. However, this difference is not considered to be clinically relevant. The between-subject variability (% coefficient of variation) in AUC of XELJANZ is estimated to be approximately 27%. Population PK analysis in UC patients also indicated that XELJANZ AUC did not significantly change with patient body weight.

Hepatic Impairment: XELJANZ/XELJANZ XR is contraindicated in patients with severe hepatic impairment (see **CONTRAINDICATIONS**). Subjects with mild and moderate hepatic impairment had 3%, and 65% higher XELJANZ AUC, respectively, compared with healthy subjects.

No dose adjustment of XELJANZ/XELJANZ XR is required in patients with mild hepatic impairment. XELJANZ XR has not been studied in patients with moderate and severe hepatic impairment. Therefore, XELJANZ XR should not be used in patients with moderate hepatic impairment.

The recommended total daily dose in patients with moderate hepatic impairment is half the total daily dose recommended for patients with normal hepatic function. The recommended dose is XELJANZ 5 mg twice daily when the indicated dose in the presence of normal hepatic function is XELJANZ 10 mg twice daily; the recommended dose is XELJANZ 5 mg once daily when the indicated dose in the presence of normal hepatic function is XELJANZ 5 mg twice daily (see **DOSAGE AND ADMINISTRATION**).

XELJANZ/XELJANZ XR has not been studied in patients with severe hepatic impairment or in patients with positive hepatitis B virus or hepatitis C virus serology, and should not be used in these populations.

Renal Impairment: Subjects with mild, moderate, and severe renal impairment had 37%, 43% and 123% higher XELJANZ AUC, respectively, compared with healthy subjects. In subjects with ESRD undergoing hemodialysis, the contribution of dialysis to the total clearance of tofacitinib was relatively small.

In subjects with ESRD undergoing hemodialysis, mean AUC was approximately 40% higher compared with historical healthy subject data, consistent with approximately 30% contribution of renal clearance to the total clearance of tofacitinib. Dose adjustment is recommended in ESRD patients undergoing hemodialysis (see **DOSAGE AND ADMINISTRATION**).

No dose adjustment of XELJANZ/XELJANZ XR is required in patients with mild renal impairment. XELJANZ XR has not been studied in patients with moderate and severe renal impairment. Therefore, XELJANZ XR is not recommended in patients with moderate and severe renal impairment, including patients with ESRD undergoing hemodialysis.

The recommended total daily dose in patients with moderate or severe renal impairment, including patients with ESRD but not limited to those undergoing hemodialysis, is half the total daily dose recommended for patients with normal renal function. The recommended dose is XELJANZ 5 mg twice daily when the indicated dose in the presence of normal renal function is XELJANZ 10 mg twice daily; the recommended dose is XELJANZ 5 mg once daily when the indicated dose in the presence of normal renal function is XELJANZ 5 mg twice daily (see **DOSAGE AND ADMINISTRATION**).

In clinical trials, XELJANZ/XELJANZ XR was not evaluated in patients with baseline creatinine clearance values (estimated by the Cockcroft-Gault equation) less than 40 mL/min.

Genetic Polymorphism: Mean C_{max} and $AUC_{0-\infty}$ values of tofacitinib following administration of XELJANZ in poor metabolizers of CYP2C19 (carriers of CYP2C19*2/*2, CYP2C19*2/*3 or CYP2C19*3/*3 alleles) were approximately 15% and 17% greater, respectively, than those in normal metabolizers, indicating that CYP2C19 is a minor contributor of XELJANZ clearance.

The impact of intrinsic factors on tofacitinib following administration of XELJANZ pharmacokinetics is summarized in Figure 3 with dosage adjustment recommendations.

Figure 3: Impact of Intrinsic Factors on Tofacitinib Pharmacokinetics

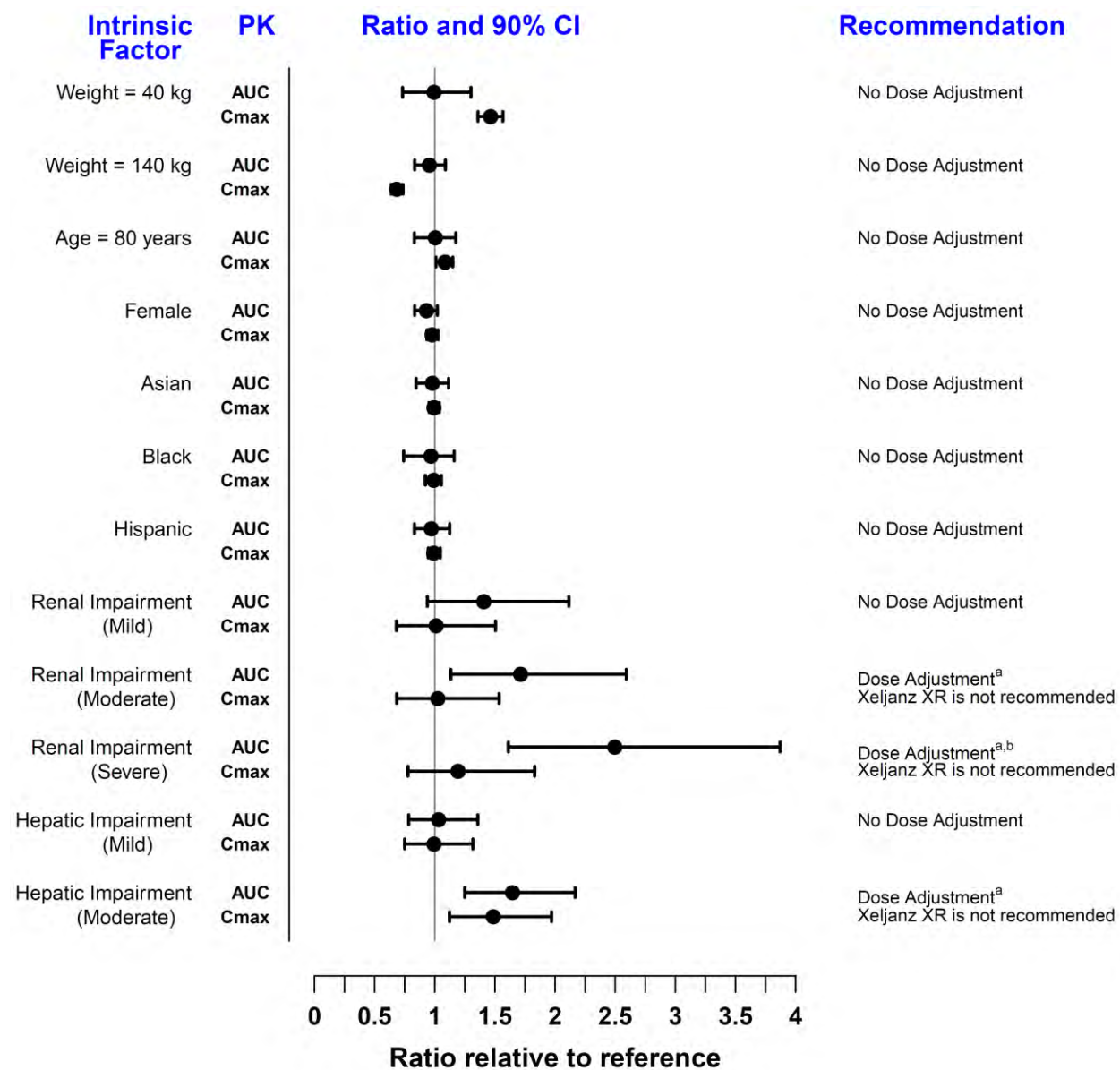

PK=Pharmacokinetics; CI=Confidence Interval

Note: Reference values for weight, age, gender, and race comparisons are 70 kg, 55 years, male, and white, respectively; reference groups for renal and hepatic impairment data are subjects with normal renal and hepatic function.

^a In RA patients the recommended dose is XELJANZ 5 mg once daily. In UC patients the recommended dose is half the total daily dose indicated for patients with normal renal and hepatic function, i.e., the recommended dose is XELJANZ 5 mg twice daily when the indicated dose in the presence of normal renal and hepatic function is XELJANZ 10 mg twice daily, and the recommended dose is XELJANZ 5 mg once daily when the indicated dose in the presence of normal renal and hepatic function is XELJANZ 5 mg twice daily.

^b Supplemental doses are not necessary in patients after dialysis.

Psoriatic Arthritis

Results from population PK analysis in patients with active PsA were consistent with those in patients with RA.

STORAGE AND STABILITY

Store between 15°C and 30°C.

DOSAGE FORMS, COMPOSITION AND PACKAGING

XELJANZ

Tablet: 5 mg tofacitinib (as tofacitinib citrate) (White round film coated tablet with Pfizer on one side and JKI 5 on the other side)

HDPE bottles with desiccant and child-resistant caps containing 60 film-coated tablets.

Foil / foil blisters containing 56 film-coated tablets.

The tablet core contains Croscarmellose Sodium, Lactose Monohydrate, Magnesium Stearate, Microcrystalline Cellulose. The film coat contains HPMC 2910/Hypromellose 6 cP, Lactose Monohydrate, Macrogol/PEG 3350, Titanium dioxide, Triacetin (Glycerol Triacetate)

Tablet: 10 mg (Blue round film coated tablet with Pfizer on one side and JKI 10 on the other side)

HDPE bottles with desiccant and child-resistant caps containing 60 film-coated tablets.

Foil / foil blisters containing 56 film-coated tablets.

The tablet core contains: Microcrystalline Cellulose, Lactose Monohydrate, croscarmellose Sodium, Magnesium Stearate. The film coat contains: HPMC 2910/Hypromellose 6cP, lactose monohydrate, macrogol/PEG3350, titanium dioxide, triacetin (glycerol triacetate), FD&C blue #2/indigo carmine aluminum lake, FD&C blue #1/brilliant blue FCF aluminum lake.

XELJANZ XR

Tablets: 11 mg tofacitinib (as tofacitinib citrate) (Pink oval extended-release-coated tablets)

HDPE bottles with desiccant and child-resistant caps containing 14 or 30 extended release film-coated tablets.

The tablet core contains: sorbitol, hydroxyethyl cellulose, copovidone, magnesium stearate. The Film Coat contains cellulose acetate, hydroxypropyl cellulose, HPMC 2910/hypromellose, titanium dioxide, triacetin, red iron oxide. The Printing ink contains shellac glaze, ammonium hydroxide, propylene glycol, ferrosulfate/black iron oxide.

PART II: SCIENTIFIC INFORMATION

PHARMACEUTICAL INFORMATION

The active ingredient in XELJANZ (tofacitinib, CP-690,550) is the citrate salt and is designated as CP-690,550-10.

CP-690,550-10 powder is a white to off-white powder with the following chemical name: (3R,4R)-4-methyl-3-(methyl-7H-pyrrolo[2,3-d]pyrimidin-4-ylamino)-β-oxo-1-piperidinepropanenitrile, 2-hydroxy-1,2,3-propanetricarboxylate (1:1) .

The solubility of CP-690,550-10 in water (unbuffered; pH 3.54) is 2.9 mg/mL.

CP-690,550-10 has a molecular weight of 504.5 Daltons (or 312.4 Daltons as the CP 690,550 free base) and a molecular formula of $C_{16}H_{20}N_6O \cdot C_6H_8O_7$. The chemical structure of CP-690,550-10 is:

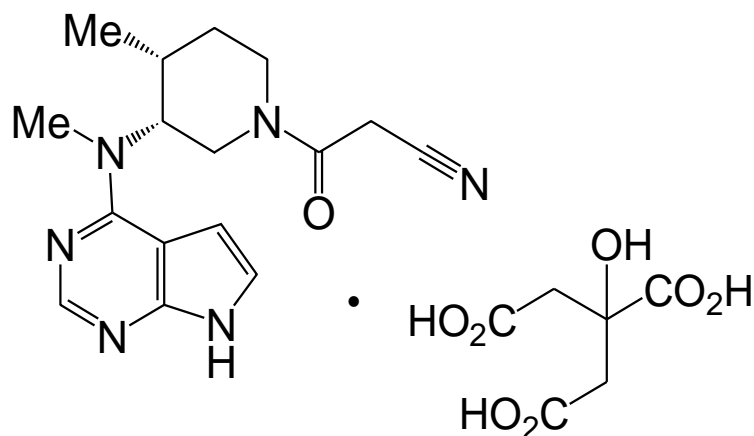

CLINICAL TRIALS

Rheumatoid Arthritis

Description of Clinical Studies

The efficacy and safety of XELJANZ were assessed in five randomized, double-blind, multicenter studies in patients ≥ 18 years with active RA diagnosed according to American College of Rheumatology (ACR) criteria. Patients had ≥ 6 tender and ≥ 6 swollen joints at randomization (≥ 4 swollen and ≥ 4 tender joints for Study II). XELJANZ, 5 or 10 mg BID, was given as monotherapy (Study I) and in combination with nonbiologic DMARDs (Study II) in patients with an inadequate response to DMARDs (nonbiologic or biologic). XELJANZ, 5 or 10 mg BID, was given in combination with methotrexate in patients with either an inadequate response to MTX (Studies III and Study IV) or inadequate efficacy or lack of tolerance to at least one approved TNF-inhibiting biologic agent (Study V).

The primary endpoints for Studies I and V were the proportion of patients who achieved an ACR20 response, mean change from baseline in HAQ-DI and proportion of patients who achieved DAS28-4(ESR) less than 2.6 at Month 3. The primary endpoints for Studies II, III, and IV were the proportion of patients who achieved an ACR20 response at Month 6, mean change from baseline in HAQ-DI at Month 3 and proportion of patients who achieved DAS28-4(ESR) less than 2.6 at Month 6.

Baseline demographics were generally similar among the treatment groups in each study and comparable between the studies. The mean age ranged from 50 to 56 years. Most (80 to 87%) of the patients were female. With the exception of Study A3921044 (46%), the majority (55% to 86%) of the patients in each study were white. The baseline demographics in each study are shown in Table 10.

Study demographics and trial design

Table 10: Summary of patient demographics for clinical trials in RA

Study #	Trial design	Dosage, route of administration and duration	Study subjects (n)	Age (yrs) Mean (Range)	Female (%)	Mean Disease Duration (yrs)
Background DMARD Studies*						
A3921046 Study II Sync	MC, DB, PG, PC, R, Background DMARD 12 Months	XELJANZ: 5 mg BID, 10 mg BID Placebo → 5 mg Placebo → 10 mg NR advance to next period at 3 months, All advance to next period at 6 months	792	52.3 (18-86)	81.4	8.1-10.2
A3921064 Study III Standard	MC, DB, PG, PC, R, Background MTX 12 Months	XELJANZ: 5 mg BID, 10 mg BID Placebo → 5 mg Placebo → 10 mg Adalimumab 40 mg sc QOW NR advance to next period at 3 months, All advance to next period at 6 months.	717	52.9 (18-83)	81.7	6.9-9.0
A3921044 (1-Year Analysis) Study IV Scan	MC, DB, PG, PC, R, Background MTX 24 Months	XELJANZ: 5 mg BID, 10 mg BID Placebo → 5 mg Placebo → 10 mg NR advance to next period at 3 months, All advance to next period at 6 months	797	[52.0-53.7]**(18-82)	85.2	8.8-9.5
A3921032 Study V Step	MC, DB, PG, PC, R, Background MTX 6 Months	XELJANZ: 5 mg BID, 10 mg BID Placebo → XELJANZ 5 mg BID at 3 months Placebo → XELJANZ 10 mg BID at 3 months	399	55.0 (20-84)	84.0	11.2-13.0

Monotherapy Studies						
A3921045 (Study I) Solo	MC, DB, PG, PC, R 6 Months	XELJANZ 5 mg BID, 10 mg BID Placebo → 5 mg XELJANZ at 3 months, Placebo → 10 mg BID XELJANZ at 3 months	610	51.8 (21- 81)	86.6	7.3-8.6

*In addition to their randomized treatment, all patients in background DMARD studies also received methotrexate (specified in Studies 1032, 1044, and 1064, permitted in Study 1046) or other DMARDs, mostly methotrexate (Study 1046).

** Range of mean across treatment groups.

N = number of patients randomized, MC = multicenter, DB = double blind, PG = parallel group, PC = placebo controlled, R = randomized, NR = nonresponder (patient who failed to improve at Month 3 by at least 20% from baseline in the number of swollen and tender/painful joint count), MTX = methotrexate, DMARD = disease modifying antirheumatic drug, sc = subcutaneous, QOW = every other week, LT = long term, OL = open label.

Study Results

Clinical Response:

In Studies I and V, patients treated with 5 mg BID XELJANZ had statistically superior ACR20, ACR50, and ACR70 response rates at month 3 vs. placebo-treated patients. In Studies II, III and IV, patients treated with 5 mg BID XELJANZ had statistically superior ACR20, ACR50, and ACR70 response rates at month 3 and 6 vs placebo-treated patients (Table 11). In Studies I, II and V, improvement in ACR20 response rate vs. placebo was observed within 2 weeks. In studies II, III, and IV, ACR response rates were maintained to 12 months in XELJANZ treated patients.

The percent of ACR20 responders by visit for study IV is shown in Figure 4. Similar responses were observed in Studies I, II, III and V.

The proportion of patients with DAS28-4(ESR) less than 2.6 for each study is summarized in Table 12.

Table 11: Proportion of Patients with an ACR Response

	Percent of Patients										
	Monotherapy		DMARD Inadequate Responders		MTX Inadequate Responders			MTX Inadequate Responders		TNF Inhibitor Inadequate Responders	
	Study I (SOLO)		Study II (SYNC)		Study III (Standard)			Study IV (SCAN)		Study V (STEP)	
Response Rate	PBO N=120	XELJANZ 5 mg BID N=241	PBO + DMARD N=157	XELJANZ 5 mg BID + DMARD N=311	PBO + MTX N=106	XELJANZ 5 mg BID + MTX N=196	ADA 40mg QW + MTX N=199	PBO + MTX N=154	XELJANZ 5 mg BID + MTX N=309	PBO N=131	XELJANZ 5 mg BID + MTX N=132
ACR20[†] Month 3 Month 6	27% NA	60%*** 69%	27% 31%	56%*** 53%***	26% 28%	61%*** 52%***	56%*** 47%**	27% 25%	56%*** 51%***	24% NA	42%* 52%
ACR50^{††} Month 3 Month 6	13% NA	31%*** 42%	10% 13%	27%*** 34%***	7% 12%	34%*** 37%***	24%*** 28%**	8% 8%	29%*** 32%***	8% NA	27%*** 37%
ACR70^{††} Month 3 Month 6	6% NA	15%* 22%	2% 3%	8%** 13%***	2% 2%	12%** 20%***	9%* 9%*	3% 1%	11%** 15%***	2% NA	14%** 16%

* $p < 0.05$, XELJANZ vs. placebo + MTX/DMARD
 ** $p < 0.001$, XELJANZ vs. placebo + MTX/DMARD
 *** $p < 0.0001$, XELJANZ vs. placebo + MTX/DMARD
 † Primary endpoint, Type I error controlled
 †† Secondary Endpoint, Type I error not controlled

Figure 4: Percentage of ACR20 Responders by Visit for Study IV

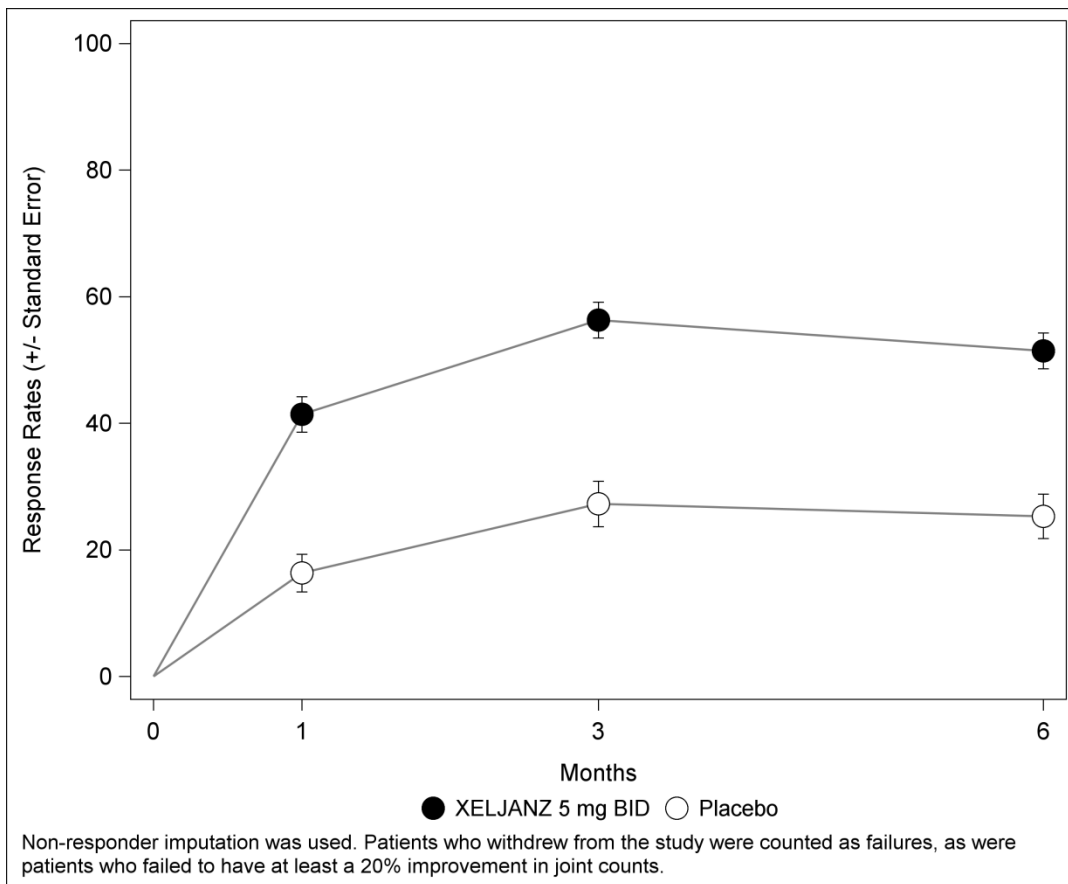

Table 12: Proportion of Patients with DAS28-4(ESR) Less Than 2.6

DAS28-4 (ESR) Less Than 2.6	Monotherapy		DMARD Inadequate Responders		MTX Inadequate Responders			MTX Inadequate Responders		TNF Inhibitor Inadequate Responders	
	Study I (SOLO)		Study II (SYNC)		Study III (Standard)			Study IV (SCAN)		Study V (STEP)	
	PBO N=122	XELJANZ 5 mg BID N=243	PBO + DMARD N=159	XELJANZ 5 mg BID + DMARD N=315	PBO + MTX N=108	XELJANZ 5 mg BID + MTX N=204	ADA 40mg QW + MTX N=204	PBO + MTX N=160	XELJANZ 5 mg BID + MTX N=321	PBO N=132	XELJANZ 5 mg BID + MTX N=133
Proportion of responders at Month 3 (n)	4% (5)	5% (13)	NA	NA	NA	NA	NA	NA	NA	2% (2)	6% (8)
Proportion of Responders at Month 6 (n)	NA	NA	3% (4)	8%* (24)	1% (1)	5% (11)	6%* (12)	1% (2)	6%†(19)	NA	NA

*Statistically significant (p<0.05)

†Statistical significance could not be declared in Study IV due to Step-down procedure

BID = twice daily, DAS = Disease Activity Score, ESR = erythrocyte sedimentation rate, N =number of patients, n = number of patients meeting pre-specified criteria

Physical Function Response:

Improvement in physical functioning was measured by the HAQ-DI. Patients receiving XELJANZ 5 mg BID demonstrated significantly greater improvement from baseline in physical functioning compared to placebo at month 3 (Studies I, II, III, and V). XELJANZ 5 mg BID treated patients exhibited significantly greater improved physical functioning compared to placebo as early as week 2 in Studies I and II. In Study III, mean HAQ-DI improvements were maintained to 12 months in XELJANZ -treated patients. At month 3, patients in the XELJANZ 5 mg BID had decreases from baseline in HAQ-DI values (Table 13) which were not less than those of adalimumab-treated patients.

Table 13: Mean Change from Baseline in HAQ-DI

	Monotherapy		DMARD Inadequate Responders		MTX Inadequate Responders			MTX Inadequate Responders		TNF Inhibitor Inadequate Responders	
	Study I (SOLO)		Study II (SYNC)		Study III (Standard)			Study IV (SCAN)		Study V (STEP)	
LS Mean Change in HAQ-DI	PBO N=109	XELJANZ 5 mg BID N=237	PBO + DMARD N=147	XELJANZ 5 mg BID + DMARD N=292	PBO + MTX N=98	XELJANZ 5 mg BID + MTX N=188	ADA 40mg QW + MTX N=190	PBO + MTX N=146	XELJANZ 5 mg BID + MTX N=294	PBO N=118	XELJANZ 5 mg BID + MTX N=117
Month 3*	-0.22	-0.51***	-0.21	-0.47***	-0.25	-0.56***	-0.51***	-0.15	-0.4 [†]	-0.18	-0.43**

* Primary efficacy time point

** $p < 0.001$, XELJANZ vs. placebo + MTX/DMARD

*** $p < 0.0001$, XELJANZ vs. placebo + MTX/DMARD

[†] Statistical significance could not be declared in Study IV due to Step-down procedure

BID = twice daily, CI = confidence interval, FAS = full analysis set, LS = least squares, N = number of patients.

Results are obtained from a longitudinal linear model with change from baseline as a dependent variable and treatment, baseline, visit, region as fixed effects and patient as random effect.

Psoriatic Arthritis

Description of Clinical Studies

The efficacy and safety of XELJANZ were assessed in 2 multicenter, randomized, double-blind, placebo-controlled trials in 816 patients 18 years of age and older with active psoriatic arthritis. All patients had active psoriatic arthritis for at least 6 months based upon the Classification Criteria for Psoriatic Arthritis (CASPAR), at least 3 tender/painful joints and at least 3 swollen joints at screening and baseline, and active plaque psoriasis at screening. Patients with different psoriatic arthritis subtypes (not mutually exclusive) were enrolled across the 2 clinical trials, including <5 joints or asymmetric involvement (21%), ≥ 5 joints involved (90%), distal interphalangeal (DIP) joint involvement (61%), arthritis mutilans (8%), enthesitis (80%), dactylitis (53%), total psoriatic body surface area (BSA) $>3\%$ (69%), and spondylitis (19%). Patients in these clinical trials had a diagnosis of psoriatic arthritis for a median of 5.5 years (median range 3.0-6.0 years). Of the study population randomized in the double-blind, controlled clinical studies, 54.2% were female and 94.6% were white. The mean age was 48.9 years; 77 (9.4%) patients were 65 years of age or older. All patients were required to receive treatment with a stable dose of a conventional synthetic DMARD (csDMARD; 78% received methotrexate, 13% received sulfasalazine, 7% received leflunomide, 1% received other csDMARDs) and were allowed to receive a stable low dose of oral corticosteroids (21% received equivalent to ≤ 10 mg/day of prednisone) and/or nonsteroidal anti-inflammatory drugs (NSAIDs; 57% received). In both clinical trials, the primary endpoints were the ACR20 response and the change in HAQ-DI at Month 3.

Study PsA-I (A3921091) was a 12-month clinical trial in 422 patients who had an inadequate response to a csDMARD (67% and 33% were inadequate responders to 1 csDMARD and ≥ 2 csDMARDs, respectively) and who were naïve to treatment with a TNF-inhibitor biologic DMARD (TNFi). Patients were randomized in a 2:2:2:1:1 ratio to receive XELJANZ 5 mg twice daily, XELJANZ 10 mg twice daily, adalimumab 40 mg subcutaneously once every 2 weeks, placebo to XELJANZ 5 mg twice daily treatment sequence, or placebo to XELJANZ 10 mg twice daily treatment sequence, respectively; study drug was added to background csDMARD treatment. At the Month 3 visit, all patients randomized to placebo treatment were advanced in a blinded fashion to a predetermined XELJANZ dose of 5 mg or 10 mg twice daily. Study PsA-I was not designed to demonstrate non-inferiority or superiority to adalimumab.

Study PsA-II (A3921125) was a 6-month clinical trial in 394 patients who had an inadequate response to at least 1 approved TNFi (66%, 19% and 15% were inadequate responders to 1 TNFi, 2 TNFi, and ≥ 3 TNFi, respectively). Patients were randomized in a 2:2:1:1 ratio to receive XELJANZ 5 mg twice daily, XELJANZ 10 mg twice daily, placebo to XELJANZ 5 mg twice daily treatment sequence, or placebo to XELJANZ 10 mg twice daily treatment sequence, respectively; study drug was added to background csDMARD treatment. At the Month 3 visit, placebo patients were advanced in a blinded fashion to a predetermined XELJANZ dose of 5 mg or 10 mg twice daily as in Study PsA-I.

Study Results

Clinical Response:

Signs and symptoms

At Month 3, patients treated with XELJANZ 5 mg twice daily had higher ($p \leq 0.05$) response rates versus placebo for ACR20, ACR50, and ACR70 in Study PsA-I and for ACR20 and ACR50 in Study PsA-II; ACR70 response rate was also higher for XELJANZ 5 mg twice daily versus placebo in Study PsA-II, although the difference versus placebo was not statistically significant ($p > 0.05$) (Table 14).

Table 14: Proportion (%) of PsA Patients Who Achieved Clinical Response and Mean Change from Baseline in PsA-I and PsA-II Studies

Treatment Group	Conventional Synthetic DMARD Inadequate Responders ^a (TNFi-Naïve)			TNFi Inadequate Responders ^b	
	Study PsA-I			Study PsA-II ^c	
	Placebo	XELJANZ 5 mg Twice Daily	Adalimumab 40 mg SC q2W ^f	Placebo	XELJANZ 5 mg Twice Daily
N	105	107	106	131	131
ACR20					
Month 3	33%	50%*	52%	24%	50%***
Month 6	NA	59%	64%	NA	60%
Month 12	NA	68%	60%	-	-
ACR50					
Month 3	10%	28%**	33%	15%	30%*
Month 6	NA	38%	42%	NA	38%
Month 12	NA	45%	41%	-	-
ACR70					
Month 3	5%	17%*	19%	10%	17%
Month 6	NA	18%	30%	NA	21%
Month 12	NA	23%	29%	-	-
Δ LEI ^d					
Month 3	-0.4	-0.8	-1.1	-0.5	-1.3
Month 6	NA	-1.3	-1.3	NA	-1.5
Month 12	NA	-1.7	-1.6	-	-
Δ DSS ^d					
Month 3	-2.0	-3.5	-4.0	-1.9	-5.2
Month 6	NA	-5.2	-5.4	NA	-6.0
Month 12	NA	-7.4	-6.1	-	-
PASI75 ^e					
Month 3	15%	43%***	39%	14%	21%
Month 6	NA	46%	55%	NA	34%
Month 12	NA	56%	56%	-	-

* $p \leq 0.05$; ** $p < 0.001$; *** $p < 0.0001$ for active treatment versus placebo at Month 3 achieved statistical significance; with the correction for type 1 error.

Abbreviations: BSA=body surface area; Δ LEI=change from baseline in Leeds Enthesitis Index; Δ DSS=change from baseline in Dactylitis Severity Score; ACR20/50/70=American College of Rheumatology $\geq 20\%$, 50%, 70% improvement; csDMARD=conventional synthetic disease-modifying antirheumatic drug; N=number of randomised and treated patients; NA=Not applicable, as data for placebo treatment is not available beyond Month 3 due to placebo advanced to XELJANZ

5 mg twice daily or XELJANZ 10 mg twice daily; SC q2w=subcutaneously once every 2 weeks; TNFi=tumour necrosis factor inhibitor; PASI=Psoriasis Area and Severity index; PASI75= $\geq 75\%$ improvement in PASI.

^a Inadequate response to at least 1 csDMARD due to lack of efficacy and/or intolerability.

^b Inadequate response to a least 1 TNFi due to lack of efficacy and/or intolerability.

^c Study PsA-II had a duration of 6 months.

^d Statistical significance cannot be claimed for these endpoints based on step-down testing procedure. Baseline score was >0 in these patients.

^e For patients with Baseline BSA $\geq 3\%$ and PASI >0 .

^f Arm is not controlled for type 1 error

As with the ACR responses, in patients treated with XELJANZ 5 mg twice daily in Studies PsA-I and PsA-II, each of the components of the ACR response was consistently improved from baseline at Month 3 including tender/painful and swollen joint counts, patient assessment of arthritis pain, patient and physician's global assessment of arthritis, HAQ-DI, and CRP compared to patients receiving placebo (Table 15).

Table 15: Components of ACR Response at Baseline and Month 3 in Studies PsA-I and PsA-II

Treatment Group	Conventional Synthetic DMARD Inadequate Responders (TNFi-Naïve)			TNFi Inadequate Responders	
	Study PsA-I			Study PsA-II	
	Placebo	XELJANZ 5 mg Twice Daily	Adalimumab 40 mg SC q2W	Placebo	XELJANZ 5 mg Twice Daily
N at Baseline	105	107	106	131	131
ACR Component ^a					
Number of tender/painful joints (0-68)					
Baseline	20.6	20.5	17.1	19.8	20.5
Month 3	14.6	12.2	10.8	15.1	11.5
Number of swollen joints (0-66)					
Baseline	11.5	12.9	9.8	10.5	12.1
Month 3	7.1	6.3	4.0	7.7	4.8
Patient assessment of arthritis pain ^b					
Baseline	53.2	55.7	50.7	54.9	56.4
Month 3	44.7	34.7	32.5	48.0	36.1
Patient global assessment of arthritis ^b					
Baseline	53.9	54.7	50.6	55.8	57.4
Month 3	44.4	35.5	32.9	49.2	36.9
HAQ-DI ^c					
Baseline	1.11	1.16	1.10	1.25	1.26
Month 3	0.95	0.81	0.75	1.09	0.88
Physician's Global Assessment of Arthritis ^b					
Baseline	53.8	54.6	50.5	53.7	53.5
Month 3	35.4	29.5	26.3	36.4	27.0
CRP (mg/L)					
Baseline	10.4	10.5	14.3	12.1	13.8
Month 3	8.60	4.02	3.10	11.44	7.72

^a Data shown are mean value at baseline and at Month 3

^b Visual analog scale (VAS): 0 = best, 100 = worst

^c HAQ-DI = Health Assessment Questionnaire – Disability Index: 0 = best, 3 = worst; 20 questions; categories: dressing and grooming, arising, eating, walking, hygiene, reach, grip, and activities

The percentage of ACR20 responders by visit for Studies PsA-I and PsA-II is shown in Figure 5. In XELJANZ-treated patients in both Studies PsA-I and PsA-II, significantly higher ACR20 response rates were observed within 2 weeks compared to placebo (Figure 5).

Figure 5: Percentage of ACR20 Responders by Visit

a) Through Month 12 in Study PsA-I

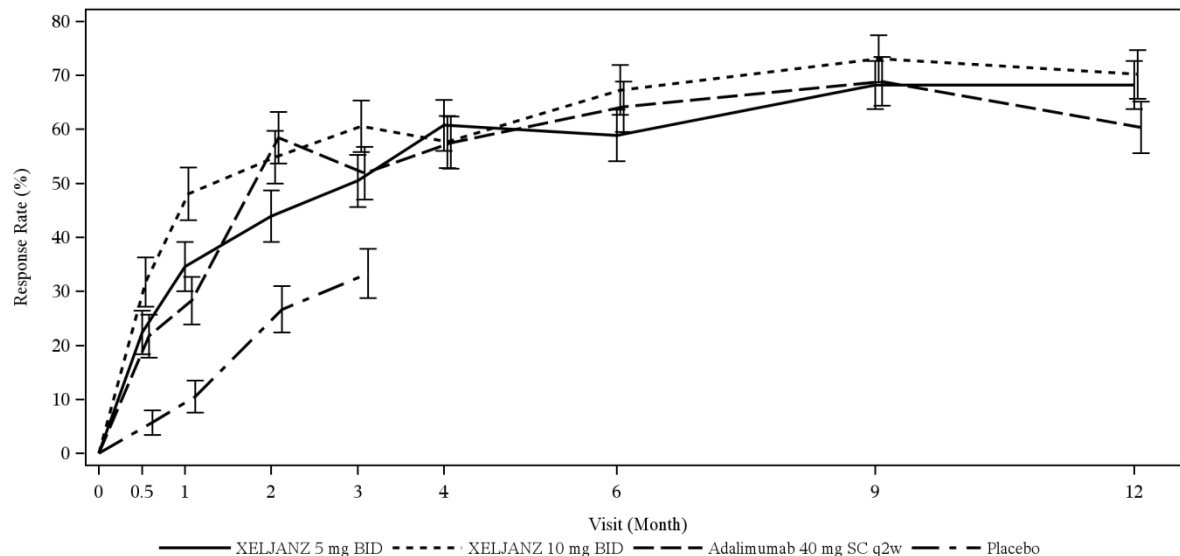

b) Through Month 6 in Study PsA-II^a

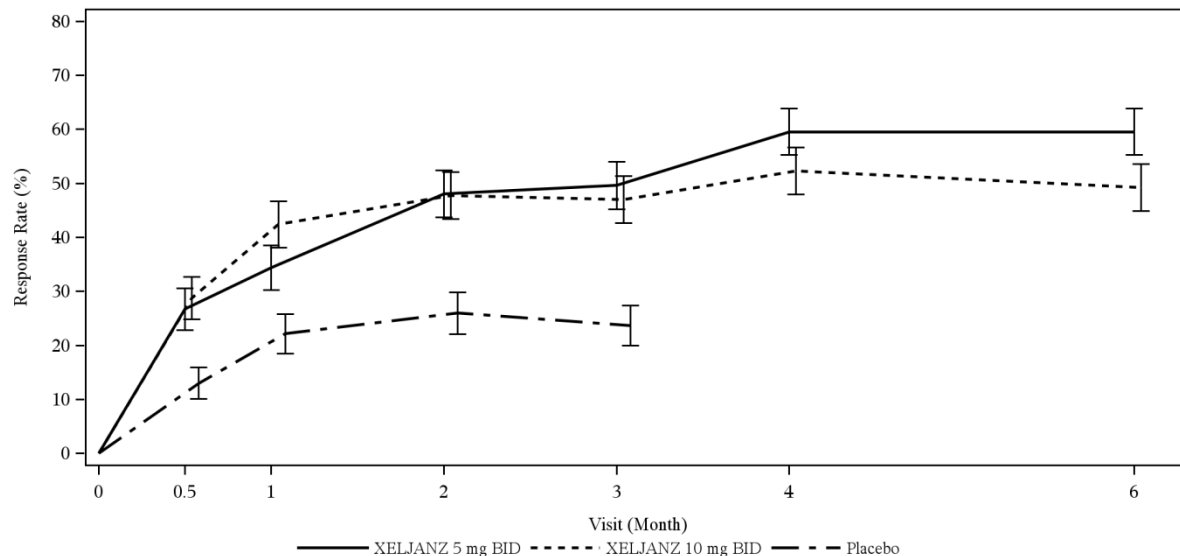

In Studies PsA-I and PsA-II, the comparison of XELJANZ 5 mg twice daily, XELJANZ 10 mg twice daily, and adalimumab (Study PsA-I only) to placebo was significant (p -value ≤ 0.05) at Months 0.5, 1, 2, and 3.

BID = twice daily; SC q2w = subcutaneously once every 2 weeks.

Patients randomized to placebo treatment were advanced to either XELJANZ 5 mg or 10 mg twice daily in a blinded manner at Month 3; results for the XELJANZ portion of the placebo→XELJANZ treatment sequence (i.e., post-Month 3) are not included in the figure to improve readability.

^a Study PsA-II had a duration of 6 months.

Physical Function:

Improvement in physical functioning was measured by the HAQ-DI. Patients receiving XELJANZ 5 mg twice daily demonstrated greater improvement ($p \leq 0.05$) from baseline in physical functioning compared to placebo at Month 3 (Table 16).

Table 16: Change from Baseline in HAQ-DI in Studies PsA-I and PsA-II

Treatment Group	Least Squares Mean Change From Baseline in HAQ-DI				
	Conventional Synthetic DMARD Inadequate Responders ^a (TNFi-Naïve)			TNFi Inadequate Responders ^b	
	Study PsA-I			Study PsA-II	
	Placebo	XELJANZ 5 mg Twice Daily	Adalimumab 40 mg SC q2W ^c	Placebo	XELJANZ 5 mg Twice Daily
N	104	107	106	131	129
Month 3	-0.18	-0.35*	-0.38	-0.14	-0.39***
Month 6	NA	-0.45	-0.43	NA	-0.44
Month 12	NA	-0.54	-0.45	NA	NA

* p≤0.05; *** p<0.0001 for active treatment versus placebo at Month 3 achieved statistical significance; with the correction for type 1 error.

Abbreviations: DMARD=disease-modifying antirheumatic drug; HAQ-DI=Health Assessment Questionnaire Disability Index; N=total number of patients in the statistical analysis; SC q2w=subcutaneously once every 2 weeks; TNFi=tumour necrosis factor inhibitor; NA=Not applicable, as data for placebo treatment is not available beyond Month 3 due to placebo advanced to XELJANZ 5 mg twice daily or XELJANZ 10 mg twice daily.

^a Inadequate response to at least one conventional synthetic DMARD (csDMARD) due to lack of efficacy and/or intolerability.

^b Inadequate response to a least one TNF inhibitor (TNFi) due to lack of efficacy and/or intolerability.

^c Arm is not controlled for type 1 error

The HAQ-DI responder rate (response defined as having decrease from baseline of ≥ 0.35) at Month 3 in Studies PsA-I and PsA-II was 53% and 50% , respectively in patients receiving XELJANZ 5 mg twice daily, 31% and 28%, respectively in patients receiving placebo, and 53% in patients receiving adalimumab 40 mg subcutaneously once every 2 weeks (Study PsA-I only).

Ulcerative Colitis

Description of Clinical Studies

The efficacy and safety of XELJANZ for the treatment of adult patients with moderately to severely active ulcerative colitis (Mayo score 6 to 12 with endoscopy subscore ≥ 2 and rectal bleeding subscore ≥ 1) were assessed in 3 multicentre, double blind, randomised, placebo controlled studies: 2 identical induction studies OCTAVE Induction 1 and OCTAVE Induction 2 followed by 1 maintenance study OCTAVE Sustain. Enrolled patients had failed at least one conventional therapy, including corticosteroids, immunomodulators, and/or a TNF inhibitor. Concomitant stable doses of oral aminosalicylates and corticosteroids (prednisone daily dose up to 25 mg equivalent) were permitted with taper of corticosteroids to discontinuation mandated within 15 weeks of entering the maintenance study. XELJANZ was administered as monotherapy (i.e., without concomitant use of biologics and immunosuppressants) for ulcerative colitis.

Table 17: Phase 3 Clinical Trials of Tofacitinib 5 and 10 mg Twice Daily Doses in Patients with UC

Studies	OCTAVE Induction 1 (A3921094)	OCTAVE Induction 2 (A3921095)	OCTAVE Sustain (A3921096)
Treatment groups (Randomisation ratio)	XELJANZ 10 mg twice daily Placebo (4:1)	XELJANZ 10 mg twice daily Placebo (4:1)	XELJANZ 5 mg twice daily XELJANZ 10 mg twice daily Placebo (1:1:1)
Number of patients enrolled	598	541	593
Study duration	8 weeks	8 weeks	52 weeks
Primary efficacy endpoints	Remission	Remission	Remission
Key secondary efficacy endpoints	Improvement of endoscopic appearance of the mucosa	Improvement of endoscopic appearance of the mucosa	Improvement of endoscopic appearance of the mucosa Sustained corticosteroid-free remission among patients in remission at baseline
Prior TNFi failure	51.3%	52.1%	44.7%
Prior corticosteroid failure	74.9%	71.3%	75.0%
Prior immunosuppressant failure	74.1%	69.5%	69.6%
Baseline corticosteroid use	45.5%	46.8%	48.7%

TNFi=tumour necrosis factor inhibitor

In addition, an open-label long-term extension study (OCTAVE Open) was also performed (see further down for more information)

Induction Efficacy Data (OCTAVE Induction 1 and OCTAVE Induction 2):

The primary endpoint of OCTAVE Induction 1 and OCTAVE Induction 2 was the proportion of patients in remission at Week 8 (i.e., a total Mayo score ≤ 2 with no individual subscore >1 , and rectal bleeding subscore of 0). The key secondary endpoint was the proportion of patients with improvement of endoscopic appearance of the mucosa at Week 8. (i.e., endoscopy subscore of 0 or 1). Central endoscopy readings were used for these endpoints.

A significantly greater proportion of patients treated with XELJANZ 10 mg twice daily achieved remission and improvement of endoscopic appearance of the mucosa at Week 8 compared to placebo in both studies, as shown in Table 18.

Table 18: Proportion of Patients Meeting Efficacy Endpoints at Week 8 (OCTAVE Induction 1 and OCTAVE Induction 2, Central Endoscopy Read)

OCTAVE Induction 1			
Endpoint	Placebo	XELJANZ 10 mg Twice daily	Difference Between XELJANZ 10 mg Twice Daily and Placebo (95% CI)
	N=122	N=476	
Remission ^a	8.2%	18.5%	10.3 (4.3, 16.3) [‡]
Improvement of endoscopic appearance of the mucosa ^b	15.6%	31.3%	15.7 (8.1, 23.4) [†]
OCTAVE Induction 2			
Endpoint	Placebo	XELJANZ 10 mg Twice daily	Difference Between XELJANZ 10 mg Twice Daily and Placebo (95% CI)
	N=112	N=429	
Remission ^a	3.6%	16.6%	13.0 (8.1, 17.9) [†]
Improvement of endoscopic appearance of the mucosa ^b	11.6%	28.4%	16.8 (9.5, 24.1) [†]

† p<0.001; ‡ p<0.05.

N=number of patients in the analysis set.

^a. Primary endpoint: Remission was defined as clinical remission (a Mayo score ≤ 2 with no individual subscore > 1) and rectal bleeding subscore of 0.

^b. Key secondary endpoint: improvement of endoscopic appearance of the mucosa was defined as Mayo endoscopy subscore of 0 (normal or inactive disease) or 1 (erythema, decreased vascular pattern).

In both subgroups of patients with or without prior TNF inhibitor failure, a greater proportion of patients treated with XELJANZ 10 mg twice daily achieved remission and improvement of endoscopic appearance of the mucosa at Week 8 as compared to placebo. This treatment difference was consistent between the 2 subgroups (Table 19).

Table 19: Proportion of Patients Meeting Primary and Key Secondary Efficacy Endpoints at Week 8 by TNF Inhibitor Therapy Subgroups (OCTAVE Induction 1 and OCTAVE Induction 2 Central Endoscopy Read)

OCTAVE Induction 1 (A3921094)		
Endpoint	Placebo N=122	XELJANZ 10 mg twice daily N=476
Remission at Week 8 ^a		
With prior TNF inhibitor failure	1.6% (1/64)	11.1% (27/243)
Without prior TNF inhibitor failure ^b	15.5% (9/58)	26.2% (61/233)
Improvement of endoscopic appearance of the mucosa at Week 8 ^c		
With prior TNF inhibitor failure	6.3% (4/64)	22.6% (55/243)
Without prior TNF inhibitor failure ^b	25.9% (15/58)	40.3% (94/233)

OCTAVE Induction 2 (A3921095)		
Endpoint	Placebo N=112	XELJANZ 10 mg twice daily N=429
Remission at Week 8^a		
With prior TNF inhibitor failure ^d	0.0% (0/60)	11.7% (26/222)
Without prior TNF inhibitor failure ^b	7.7% (4/52)	21.7% (45/207)
Improvement of endoscopic appearance of the mucosa at Week 8^c		
With prior TNF inhibitor failure ^d	6.7% (4/60)	21.6% (48/222)
Without prior TNF inhibitor failure ^b	17.3% (9/52)	35.7% (74/207)

TNF=tumour necrosis factor; N=number of patients in the analysis set.

- ^a. Remission was defined as clinical remission (a Mayo score ≤ 2 with no individual subscore >1) and rectal bleeding subscore of 0.
- ^b. Failed one or more conventional therapies (corticosteroid, azathioprine, 6-mercaptopurine) but did not have history of prior failure of TNF inhibitor therapy.
- ^c. Improvement of endoscopic appearance of the mucosa was defined as Mayo endoscopy subscore of 0 (normal or inactive disease) or 1 (erythema, decreased vascular pattern).
- ^d. Inadequate response, loss of response, or intolerance to TNF inhibitor therapy.

Decreases in rectal bleeding and stool frequency subscores were observed as early as Week 2 in patients treated with XELJANZ.

Clinical response was defined as a decrease from baseline in Mayo score of ≥ 3 points and $\geq 30\%$, with an accompanying decrease in the subscore for rectal bleeding of ≥ 1 point or absolute subscore for rectal bleeding of 0 or 1. Clinical response was observed in 60% of patients treated with XELJANZ 10 mg twice daily compared to 33% of placebo patients in Octave Induction 1 and 55% compared to 29% in Octave Induction 2.

Maintenance (OCTAVE Sustain):

A total of 593 patients who completed 8 weeks in one of the induction studies and achieved clinical response were re-randomized into OCTAVE Sustain; 179 out of 593 (30%) patients were in remission at baseline of OCTAVE Sustain.

The primary endpoint was the proportion of patients in remission at Week 52. The 2 key secondary endpoints were the proportion of patients with improvement of endoscopic appearance of the mucosa at Week 52, and the proportion of patients with sustained corticosteroid-free remission at both Week 24 and Week 52 among patients in remission at baseline of OCTAVE Sustain.

A significantly greater proportions of patients in both the XELJANZ 5 mg twice daily and XELJANZ 10 mg twice daily treatment groups achieved the primary and two key secondary endpoints, as shown in Table 20.

Table 20: Proportion of Patients Meeting Primary and Key Secondary Efficacy Endpoints at Week 52 (Maintenance OCTAVE Sustain, Central Endoscopy Read)

Endpoint	Placebo N=198	XELJANZ 5 mg twice daily N=198	Difference Between XELJANZ 5 mg Twice Daily and Placebo (95% CI)	XELJANZ 10 mg twice daily N=197	Difference Between XELJANZ 10 mg Twice Daily and Placebo (95% CI)
Remission ^a	11.1%	34.3%	23.2 (15.3, 31.2)*	40.6%	29.5 (21.4, 37.6)*
Improvement of endoscopic appearance of the mucosa ^b	13.1%	37.4%	24.2 (16.0, 32.5)*	45.7%	32.6 (24.2, 41.0)*
Sustained corticosteroid-free remission at both Week 24 and Week 52 among patients in remission at baseline ^c	N = 59 5.1%	N = 65 35.4%	30.3 (17.4, 43.2)*	N = 55 47.3%	42.2 (27.9, 56.5)*

* p<0.0001

N=number of patients in the analysis set.

a. Remission was defined as clinical remission (a Mayo score ≤ 2 with no individual subscore >1) and rectal bleeding subscore of 0.

b. Improvement of endoscopic appearance of the mucosa was defined as Mayo endoscopy subscore of 0 (normal or inactive disease) or 1 (erythema, decreased vascular pattern).

c. Sustained corticosteroid-free remission was defined as being in remission and not taking corticosteroids for at least 4 weeks prior to the visit at both Week 24 and Week 52.

Additionally, among the 179 patients in remission at baseline (59 in the placebo group, 65 in the XELJANZ 5 mg BID group, and 55 in the XELJANZ 10 mg BID group), the rate of patients with remission at week 52 (i.e., maintained remission) was larger with XELJANZ 5 mg BID (46%) and 10 mg BID (56%) as compared to placebo (10%).

In both subgroups of patients with or without prior TNF inhibitor failure, the proportions of patients treated with either XELJANZ 5 mg twice daily or XELJANZ 10 mg twice daily were numerically larger as compared to placebo for the primary and key secondary endpoints, however, statistical significance was not possible to determine (see Table 21).

Table 21: Proportion of Patients Meeting Primary and Key Secondary Efficacy Endpoints in Maintenance Study OCTAVE Sustain (A3921096) by TNF Inhibitor Therapy Subgroup (Central Endoscopy Read)

Endpoint	Placebo N=198	XELJANZ 5 mg twice daily N=198	XELJANZ 10 mg twice daily N=197
Remission at Week 52 ^a			
With prior TNF inhibitor failure ^e	10/89 (11.2%)	20/83 (24.1%)	34/93 (36.6%)
Without prior TNF inhibitor failure ^b	12/109 (11.0%)	48/115 (41.7%)	46/104 (44.2%)
Improvement of endoscopic appearance of the mucosa at Week 52 ^c			
With prior TNF inhibitor failure ^e	11/89 (12.4%)	25/83 (30.1%)	37/93 (39.8%)
Without prior TNF inhibitor failure ^b	15/109 (13.8%)	49/115 (42.6%)	53/104 (51.0%)
Sustained corticosteroid-free remission at both Week 24 and Week 52 among patients in remission at baseline ^d			
With prior TNF inhibitor failure ^e	1/21 (4.8%)	4/18 (22.2%)	7/18 (38.9%)
Without prior TNF inhibitor failure ^b	2/38 (5.3%)	19/47 (40.4%)	19/37 (51.4%)

TNF=tumour necrosis factor; N=number of patients in the analysis set.

- a. Remission was defined a Mayo score ≤ 2 with no individual subscore >1 , and rectal bleeding subscore of 0
- b. Patients who failed ≥ 1 conventional therapies (corticosteroid, azathioprine, 6-mercaptopurine) but did not have history of prior failure of TNF inhibitor therapy.
- c. Improvement of endoscopic appearance of the mucosa was defined as Mayo endoscopy subscore of 0 (normal or inactive disease) or 1 (erythema, decreased vascular pattern).
- d. Sustained corticosteroid-free remission was defined as being in remission and not taking corticosteroids for at least 4 weeks prior to the visit at both Week 24 and Week 52.
- e. Prior TNF inhibitor failure was defined in this program as inadequate response, loss of response, or intolerance to TNF inhibitor therapy.

Open-label Extension Study (OCTAVE Open):

Patients who did not achieve clinical response in one of the induction studies (Study OCTAVE Induction 1 or OCTAVE Induction 2) after 8 weeks of XELJANZ 10 mg twice daily, were allowed to enter an open-label extension study (OCTAVE Open). After an additional 8 weeks of XELJANZ 10 mg twice daily in Study OCTAVE Open, 53% (155/293) patients achieved clinical response and 14% (42/292) patients achieved remission.

TOXICOLOGY

Single and Repeat-Dose Toxicity

Tofacitinib caused death in rats at single oral doses of ≥ 500 mg/kg. Single intravenous doses up to 3 mg/kg did not induce local or systemic toxicity in rats. In cynomolgus monkeys emesis and decreased activity were observed at single oral doses of ≥ 200 mg/kg (divided 3 times daily [TID], ~7 hours apart).

Immune and hematopoietic organ systems were identified as main targets in repeat-dose toxicity studies. Effects on the immune system (including decreased circulating lymphocytes, lymphoid depletion of lymph nodes, spleen, thymus and bone marrow, and bacterial and viral infections) were consistent with inhibition of JAK1/3. Decreases in hemoglobin, hematocrit, erythrocyte numbers and reticulocytes were attributed to JAK2 inhibition. These effects were generally reversible during a 4-week recovery phase in the 4- and 6-week monkey and rat studies,

respectively. Repeated oral doses up to 10 mg/kg once daily in rats (up to approximately 15 or 7.6 times human clinical exposure at 5 or 10 mg BID) and 1 mg/kg twice daily in adult cynomolgus monkeys (approximately 1 or 0.5 times human exposure at 5 or 10 mg BID) were tolerated in studies up to 6 months and 39 weeks duration, respectively. In the 39-week juvenile monkey study, the T-dependent antibody response to antigen immunization was decreased at the high dose of 5 mg/kg twice daily, approximately 5 or 2.5 times human exposure at 5 or 10 mg BID.

Mutagenesis

Tofacitinib was not mutagenic in the bacterial reverse mutation assay. Reproducible increases in chromosomal abnormalities were observed in a human lymphocyte *in vitro* cytogenetic assay, at high cytotoxic concentrations with metabolic activation, but no effects were observed without metabolic activation. In follow up studies, tofacitinib was not mutagenic in mammalian cells (*in vitro* CHO/HGPRT assay) and did not induce primary DNA damage in an *in vivo/in vitro* rat hepatocyte unscheduled DNA synthesis assay. Tofacitinib was also negative in the *in vivo* rat micronucleus test.

Carcinogenesis

In the 39-week repeat-dose toxicity study in adult monkeys, lymphomas were observed at the high dose of 5 mg/kg twice daily (approximately 6 times human exposure at 5 mg BID, or approximately 3 times the 10 mg twice daily dose), but not at the lower dose of 1 mg/kg twice daily (approximately 1 times human exposure at 5 mg BID, or approximately 0.5 times the 10 mg twice daily dose). No treatment-related tumors were observed in a 6-month rasH2 transgenic mouse study up to the high dose of 200 mg/kg/day, approximately 38 or 19 times human exposure at 5 or 10 mg BID.

In a 2-year rat carcinogenicity study, tofacitinib induced benign Leydig cell tumors and malignant hibernomas (tumors of brown adipose tissue) at oral doses of ≥ 30 mg/kg/day (≥ 35 times or 17 times human exposure at 5 or 10 mg BID) and benign thymomas at 100/75 mg/kg/day (approximately 187 or 94 times human exposure at 5 or 10 mg BID). No treatment-related tumors were found in rats at 10 mg/kg/day (approximately 16 or 8 times human exposure at 5 or 10 mg BID). The relevance of benign Leydig cell tumors to human risk is unknown.

Developmental and Reproductive Toxicity

Tofacitinib had no effect on fertility of male rats; however, in treated female rats tofacitinib decreased pregnancy rate, numbers of corpora lutea, implantation sites, and viable fetuses, with an increase in early resorptions at oral doses of ≥ 10 mg/kg/day (≥ 15 or 8 times human exposure at 5 or 10 mg BID). The non-observed-adverse-effect-level (NOAEL) for female fertility and early embryonic development was 1 mg/kg/day (approximately 1 or 0.6 times human exposure at 5 or 10 mg BID).

Tofacitinib was teratogenic (external, visceral and skeletal abnormalities) in rabbits and rats at oral doses of 30 and 100 mg/kg/day (approximately 13/6 and 146/73 times human exposure at 5/10 mg BID), respectively. In rabbits, teratogenic effects occurred in the absence of maternal toxicity, consisted of thoracogastroschisis, omphalocele, craniofacial malformations (microstomia, microphthalmia, and cleft lip and palate), membranous ventricular septal defects, gallbladder agenesis, short or absent tail, and skeletal malformations (fused sternbrae and vertebral and/or rib

anomalies). In addition, there was an increase in postimplantation loss (early and late resorptions) and consequently, reduced number of viable fetuses. The developmental NOAEL in rabbits was 10 mg/kg/day (approximately 3 or 1.5 times human exposure at 5 or 10 mg BID). In rats, tofacitinib increased postimplantation loss (early and late resorptions), reduced fetal body weights, and increased incidences of fetal malformations at doses that induced maternal toxicity. Malformations suggestive of teratogenicity included anasarca, membranous ventricular septal defects, and skeletal abnormalities (absent cervical arch, bent limb bones, hemicentric thoracic centrum, and rib and sternal anomalies). The developmental NOAEL in rats was 30 mg/kg/day (approximately 58 or 29 times human exposure at 5 or 10 mg BID).

In the peri/postnatal development study in rats, tofacitinib decreased the number of delivered and live born pups, and reduced pup survival at oral doses of 50 mg/kg/day (approximately 73 or 36 times human exposure at 5 or 10 mg BID). There was no effect on sexual maturation, or the ability of these F1 generation rats to learn, mate and produce viable F2 generation fetuses of treatment of the dams at oral doses up to 10 mg/kg/day (up to 15 or 8 times human exposure at 5 or 10 mg BID).

Table 22: Summary of Toxicology Studies

Study Type	Treatment Duration	Species/ Test system	Animals/ Group	Dose (mg/kg/day) ^a	Results
Single-Dose Toxicity					
Single-Dose Oral Toxicity Study in Sprague-Dawley Rats (01-2063-07)	Single Dose	Rat/ Sprague-Dawley	3M, 3F	0, 500, 1000, 2000 (Oral gavage, 20 mL/kg, 0.5% Methylcellulose/ Suspension)	<p>500 mg/kg: 1 female died on Day 1; red-stained fur (nose/muzzle); ↓ eosinophils, ↓ fibrinogen, ↑ ALT, ↑ AST, ↑ glucose, ↑ BUN.</p> <p>≥500 mg/kg: ↓ activity, lethargy, partially closed eyes, labored respiration, salivation; lymphocytolysis in mesenteric lymph node and decreased numbers of lymphocytes within the minimal zone of the splenic white pulp.</p> <p>1000 mg/kg: 6/6 animals died by Day 2; necrosis of centrilobular hepatocytes.</p> <p>≥1000 mg/kg: lacrimation and cold to touch; stomach distension; necrosis of individual hepatocytes; lymphocytolysis within the splenic white pulp.</p> <p>2000 mg/kg: 6/6 animals died by Day 2; slow respiration and eye staining/nasal discharge.</p>
Single-Dose IV Toxicity Study in Rats with a 14-Day Recovery (09GR453)	Single Dose	Rat/Sprague-Dawley	10M, 10F ^b	0, 0.5, 1, 3 (IV, 0.5-3 mL/kg, 10mM Lactic acid in normal saline)	≤3 mg/kg: None
Single-Day Oral Toxicity Study in Cynomolgus Monkeys (00-2063-04)	1 Day	Monkey/ Cynomolgus	2M, 2F	40, 200, 1000 ^c (Oral gavage, 7 mL/kg, 0.5% Methylcellulose/Suspension)	≥200 mg/kg: Emesis, ↓ activity
Repeat-Dose Toxicity					
Pivotal Studies					
6-Week Oral Toxicity Study with 1-Month Recovery in Sprague-Dawley Rats (01-2063-06)	6 Weeks	Rat/Sprague-Dawley	10-15/sex/dose	1, 10, 100 Oral gavage, QD, 10 mL/kg (0.5% Methylcellulose/ Suspension)	<p>1 mg/kg/day (LOEL): ↓ WBC count, ↓ lymphocytes, ↓ eosinophils, ↓ basophils, ↓ RBC count, ↓ HCT, ↓ HGB, lymphoid depletion in bone marrow.</p> <p>10 mg/kg/day: Same as above, + ↓ reticulocytes, lymphoid depletion in spleen, thymus, and mesenteric lymph node.</p> <p>100 mg/kg/day: Same as above, + ↑ neutrophils, ↑ AST.</p>

Study Type	Treatment Duration	Species/ Test system	Animals/ Group	Dose (mg/kg/day) ^a	Results
					100 mg/kg/day (Recovery): Recovery of reticulocytes and AST, no microscopic findings in lymphoid tissues, partial recovery of WBC count, lymphocytes, RBC parameters, and lymphoid cells in bone marrow.
6-Month Oral Toxicity Study in Rats (77435)	6 Months	Rat/Sprague-Dawley	15/sex/dose	1, 10, 100 (Oral gavage, QD, 10 mL/kg, 0.5% Methylcellulose/Suspension)	1 mg/kg/day (LOEL): ↓ WBC, ↓ lymphocytes, ↓ eosinophils, ↓ basophils, ↓ large unstained cells, ↓ RBC count, ↓ HCT, ↓ HGB, ↑ neutrophils (F), ↓ spleen weight, ↓ T lymphocytes, T-cells (CD3+), T-cell subtypes (CD4+, CD8+), B cells (CD45RA+), NK cells (CD161+). 10 mg/kg/day: Same as above, + ↓ reticulocytes; neutrophils, ↑ glucose, ↑ alkaline phosphatase; ↓ triglycerides (F), ↓ spleen weight, lymphoid atrophy (lymph nodes, spleen, thymus) (F), alveolar histiocytosis. 100 mg/kg/day: Same as above, + ↑ neutrophils, ↑ reticulocytes, ↑ globulin; ↓ triglycerides, ↑ liver weight; ↓ thymus weight, lymphoid atrophy (GALT), hepatocellular hypertrophy.
1-Month Oral Toxicity Study with 1-Month Recovery in Cynomolgus Monkeys (01-2063-09)	4 Weeks	Monkey/ Cynomolgus	3/sex/dose	10, 50, 100 Oral gavage, TID ^d , 5 mL/kg, 0.5% Methylcellulose/Suspension	10 mg/kg/day: ↓ lymphocytes, ↓ lymphocyte subsets (helper T cells, cytotoxic/suppressor T cells, and NK cells, ↓ HGB). 50 mg/kg/day: Same as above, + death, body weight loss, decreased activity, ↑ WBC, ↓ RBC count, ↓ HCT, ↓ reticulocytes, ↑ AST, ↑ ALT, ↓ Ca, ↓ neutrophil pool, slight granulocytic depletion in bone marrow, lymphoid depletion in spleen, bacterial and viral infection secondary to immunosuppression in heart, kidney, gastrointestinal tract, buccal cavity, and skin. 100 mg/kg/day: Same as above (except no ↑ WBC count), + RBC depletion in bone marrow, and ↑ immature myeloid cells in bone marrow, lymphoid depletion in mesenteric lymph node. 50 mg/kg/day (Recovery): Complete recovery with the exceptions of partial recovery of ↑ neutrophils, ↑ ALT and ↑ AST, ↓ (CD16+, CD3-), ↓ RBC

Study Type	Treatment Duration	Species/ Test system	Animals/ Group	Dose (mg/kg/day) ^a	Results
					count; rebound effect in lymphocytes, (CD4+, CD3+), and (CD8+, CD3+), lymphocytes, and reticulocytes.
39-Week Oral Toxicity Study in Monkeys (2003-0301)	39 weeks	Monkey/ Cynomolgus	4/sex/dose	0.5, 2, 10 ^c Oral gavage, BID, 10 mL/kg, 0.5% Methylcellulose/ Suspension	0.5 mg/kg/day (LOEL): ↓ total lymphocytes, ↓ lymphocyte subsets (T-helper, -cytotoxic/suppressor and NK cells); lymphoid hyperplasia (2/4 M). 2 mg/kg/day: Same as above +, ↓ RBC count, ↓ HCT, ↓ HGB, lymphoid hyperplasia (4/4 M) 10 mg/kg/day: Same as above, + death, ↑ reticulocytes; RBC hyperplasia in bone marrow; lymphoid hyperplasia (3/4 M, 1/4 F); lymphoma (1/4 M, 2/4 F; 2 confirmed B-cell origin), mononuclear cell infiltrates in the heart (F).
Genotoxicity					
In Vitro Studies					
Microbial Reverse Bacterial Mutation Assay (AMES) (01-2063-11)	In Vitro	<i>Salmonella typhimurium</i> , <i>Escherichia coli</i>	NA	0.010-5 mg/plate Plate Incorporation for ~ 48 to 72 hours at 37°C	No genotoxic effect. No cytotoxic effect.
Mammalian Cell Mutation Assays (01-2063-16)	In Vitro	Chinese Hamster ovary (CHO)-K1-BH4 cells,	NA	16-5000 µg/mL 5-hour treatment, 6-8 day incubation	- No Genotoxic effects - Substantial cytotoxicity at 950, 1000, and 1100 µg/mL with average Day 3 relative cell survivals of 43%, 29%, and 17%, respectively.
In Vitro Cytogenetics Assay (01-2063-10)	In Vitro	Human Peripheral Lymphocytes	NA	41.8-2400 µg/mL 3 hours with activation, 3 and 24 hours without activation	Cytotoxic Effects: ~ 50% Mitotic suppression achieved in all treatments. Genotoxic Effects: tofacitinib did not significantly increase structural chromosome aberrations at 3- and 24-hour treatments without metabolic activation. At 3 hours with metabolic activation, tofacitinib increased structural chromosome aberrations at relatively cytotoxic concentrations.

Study Type	Treatment Duration	Species/ Test system	Animals/ Group	Dose (mg/kg/day) ^a	Results
In Vivo Studies					
In Vivo/In Vitro Rat Hepatocyte Unscheduled DNA Synthesis Study (01-2063-17)	Single Dose Hepatocytes, 2-4 and 14-16 HPD	Rat/Sprague-Dawley	M	125, 250, 250 Oral gavage, 10 mL/kg, 0.5% Methylcellulose	Toxic/Cytotoxic Effects: Hypoactivity, labored breathing and/or squinted eyes in the 500 mg/kg group Genotoxic Effects: None
In Vivo Cytogenetics (Rat Micronucleus) (01-2063-12)	Once daily for 3 days	Rat/Sprague-Dawley	6M, 6F	62.5, 125, 250 Oral gavage, QD, 10 mL/kg, 0.5% Methylcellulose	Toxic/Cytotoxic Effects: No mortality or adverse clinical signs attributed to drug treatment was observed. A statistically significant decrease in mean percent body weight gain was evident in the male rats. The males also showed statistically significant treatment-related reduction in mean %PCE, suggestive of bone marrow toxicity. Genotoxic Effects: None.
Carcinogenicity					
<u>6-Month Oral Gavage Study in Mice</u> (8200-368)	6 Months	Mouse/Model 001178-T (hemizygous), CB6F1/Jic-TgrasH2@Tac Mouse/Model 001178-W (homozygous wild-type), CB6F1/Jic-TgrasH2@Tac	25/sex/dose	25, 75, 200 Oral gavage, QD, 10 mL/kg, 0.5% (w/v) Methylcellulose/ Solution	≥25 mg/kg/day: No evidence of treatment-related carcinogenicity.
<u>2-Year Oral Gavage in Rats</u> (6348-463)	103 Weeks ^f	Rat/Sprague-Dawley	60-70/ sex/dose	10/10, 30/30, 75/100 ^g Oral gavage, QD, 10 mL/kg, 0.5% Methylcellulose/ Solution	10 mg/kg/day: Benign angiomas of mesenteric lymph nodes (M). 30 mg/kg/day: Hyperplasia and benign tumors of interstitial cells of testes (M), malignant hibernomas of multiple organs (F). 75 mg/kg/day: Same as above (M). 100/75 mg/kg/day: Benign thymoma in thymus (F).
Investigative					
14-Day Oral Investigative Study in Rats (10GR431)	14 Days	Rat/Sprague-Dawley	8F with BrdU pumps 5F without BrdU pumps	Oral gavage, QD, 10 mL/kg, 0.5% Methylcellulose/ Solution	Tofacitinib inhibited JAK/STAT signaling in BAT as evidenced by decreased tissue levels of

Study Type	Treatment Duration	Species/ Test system	Animals/ Group	Dose (mg/kg/day) ^a	Results
					phosphorylated STAT3 (pSTAT3) and pSTAT5 at doses ≥ 10 mg/kg/day.
Investigative Study with Rat Brown Adipocytes (11GR016)	1 hour pre-incubation with XELJANZ then 20 minutes with oPRL and XELJANZ	Rat/Sprague-Dawley/Primary Leydig cells	In vitro	150 mM NaCl, 0.03 mM NaHCO ₃ /Solution (oPRL), 0.1% dimethyl sulphoxide/Solution (XELJANZ)	Tofacitinib inhibited the prolactin-induced increase in STAT5A/B phosphorylation.
Investigative Study with Rat Primary Leydig Cells (11GR015)	1 hour pre-incubation with XELJANZ then 15 minutes with oPRL and XELJANZ	Rat/Sprague-Dawley/ Differentiated primary brown adipocytes/ pSTAT5A/B protein	In vitro	150 mM NaCl, 0.03 mM NaHCO ₃ /Solution (oPRL), 0.1% dimethyl sulphoxide/Solution (XELJANZ)	Tofacitinib inhibited the prolactin-induced increase in STAT5A/B phosphorylation.
Reproductive and Developmental Toxicity					
Oral Fertility and Embryonic Development Study in Male and Female Rats (05GR051)	(F) Phase 1: 14 Days pre-mating, throughout cohabitation and through GD 7. (M) Phase 2: Minimum of 63 days (beginning 28 days pre-mating)	Rat/Sprague Dawley	20/sex/dose	1, 10, 100 Oral Gavage, QD, 10 mL/kg	1 mg/kg/day: No effect. 10 mg/kg/day: \uparrow Postimplantation loss. 100 mg/kg/day: Same as above, + \downarrow pregnancy rate, \downarrow corpora lutea, \downarrow implantation sites, \downarrow viable fetuses, \uparrow early resorptions, \uparrow pre-implantation loss.
Oral Embryo-Fetal Development Study in Rats (04-2063-24)	GD 6-17	Rat/Sprague Dawley	20F/dose	1, 10, 30 Oral gavage, QD, 10 mL/kg	≥ 1 mg/kg/day: No effect.
Oral Embryo-Fetal Development Study in Rats (09GR353)	GD 6-17	Rat/Sprague Dawley	20F/dose	30, 100, 300 Oral gavage, QD, 10 mL/kg	30 mg/kg/day: No effect. 100 mg/kg/day: \downarrow Viable fetuses, \downarrow uterine weight, external, visceral and skeletal malformations.

Study Type	Treatment Duration	Species/ Test system	Animals/ Group	Dose (mg/kg/day) ^a	Results
					300 mg/kg/day: ↓ Maternal body weight and food consumption, clinical signs of poor toleration, no viable fetuses to examine.
Oral Embryo-Fetal Development Study in Rabbits (05-2063-25)	GD 7-19	Rabbit/New Zealand White	20F/dose	10, 30, 100 Oral gavage, QD, 2 mL/kg	10 mg/kg/day: No effect. 30 mg/kg/day: ↓ Viable fetuses, ↓ uterine weight, external, visceral, and skeletal malformations. 100 mg/kg/day: Same as above, + ↓ fetal body weights, ↑ visceral variations.
Oral Developmental Peri/Postnatal Reproduction including Postnatal Behavioral/Functional Evaluation in Rats (LIA00468)	GD 6 - DL 21 (or GD 24 for rats not delivering a litter)	Rat/Sprague-Dawley	25F/dose	Oral gavage, QD during dosage period; 10 mL/kg	10 mg/kg/day: No effect 50 mg/kg/day: ↓ Delivered pups, ↓ liveborn pups, ↓ pup survival, ↓ pup body weight.
Developmental and Reproductive - Juvenile					
Oral Fertility Study in Juvenile Rats (10GR250)	PND 21-70 (M) PND 21-55 (F)	Rat/Sprague-Dawley	20/sex/dose	1, 10, 100 Oral gavage, QD, 10 mL/kg 0.5% (w/v) Methylcellulose/ Suspension	1 mg/kg/day: No effect. 10 mg/kg/day: ↓ BW (M), ↓ BW gain (M). 100 mg/kg/day: Same as above (M&F).
Oral Toxicity Study in Juvenile Rats with a 2-Month Recovery (10GR307)	PND 21-49	Rat/Sprague Dawley	16/sex/dose	1, 10, 100 Oral gavage, QD, 10 mL/kg 0.5% (w/v) Methylcellulose/ Suspension	1 mg/kg/day: Females: ↓WBC, ↓ lymphocytes, eosinophils, basophils Males only: ↑ vacuolation in brown adipose tissue, ↓ T cells, ↓ helper T cells, ↓ cytotoxic T cells, ↓ B cells, ↓ NK cells. 10 mg/kg/day: Same as above, ↓ T cells, ↓ helper T cells, ↓ cytotoxic T cells, ↓B cells, ↓ NK cells. Males: ↓ WBC, ↓ lymphocytes, eosinophils, basophils. Females: ↓ body weight and body weight gain, ↓ reticulocytes, ↓ cellularity (thymus) - females, ↓ cellularity (spleen), ↓ lymphoid cellularity-mesenteric lymph node.

Study Type	Treatment Duration	Species/ Test system	Animals/ Group	Dose (mg/kg/day) ^a	Results
					100 mg/kg/day: Same as above, ↓ body weight and body weight gain (M), ↓ RBC, ↓ cellularity: inguino-femoral lymph node, mandibular lymph node.
39-Week Oral Toxicity in Juvenile Monkeys with a 26-Week Recovery (Interim Report) (2501-010)	39 Weeks	Monkey/ Cynomolgus	4/sex/dose	0.5, 2, 10 Oral gavage, BID, 5 mL/kg 0.5% (w/v) Methylcellulose/ Suspension	0.5 mg/kg/day: No effect. 2 mg/kg/day: ↓ total lymphocytes (M), ↓ lymphocyte subsets (NK cells, effector CD8+ T cells, CD8+ T cells (M), ↓ thymus weight (M), ↓ spleen weight (F). 10 mg/kg/day: ↓ total lymphocytes (M + F), ↓ RBC count, ↓ HCT, ↓ HGB, ↓ lymphocyte subsets (NK cells, CD4+ and CD8+ T cells, naïve CD4+ and CD8+ T cells, central and effector memory CD8+ cells), ↓ spleen and thymus weight.

^a Doses are expressed as mg active moiety/kg/day unless otherwise noted.

^b Five/sex were necropsied on Day 2 and 5/sex were retained for a 14-day recovery period and necropsied on Day 15.

^c 13, 67, 333 mg/kg TID; 7 hours apart.

^d 3.33, 16.7, 33.3mg/kg TID; 7 hours apart.

^e 0.25, 1, 5, mg/kg BID; 12 hours apart.

^f All surviving males in Group 4 were sacrificed on Day 654 (Week 94) of the dosing phase. All surviving males in Group 1 through Group 3 were sacrificed on Day 686 (Week 98) of the dosing phase. All surviving females were sacrificed on Day 715 (Week 103) of the dosing phase.

^g Dose was lowered from 100 to 75 mg/kg/day starting on Day 133.

ALT = Alanine aminotransferase; AST = Aspartate aminotransferase; BAT = Brown adipose tissue; BID = Twice daily; BrdU = 5-bromo-2'deoxyuridine; BUN = Blood urea nitrogen; Ca = Calcium; CHO = Chinese hamster ovary; CD = Cluster of differentiation; DL = Day of lactation; F = Female; GALT = Gut associated lymphoid tissue; GGT = Gamma glutamyl transferase; GD = Gestation Day; HGB = Hemoglobin; HCT = Hematocrit; HPD = Hours postdose; IV = Intravenous; JAK = Janus kinase; LOEL = Lowest observed effect level; M = Male; NA = Not applicable; NaCl = Sodium chloride; NaHCO₃ = Sodium bicarbonate; NK = Natural killer; oPRL = Ovine prolactin; PND = Postnatal day; PCE = Polychromatic erythrocytes; pSTAT = Phosphorylated signal transducer and activator of transcription; QD = Once daily; RBC = Red blood cells; STAT = Signal transducer and activator of transcription; TID = Three times daily; WBC = White blood cells.

REFERENCES

1. Fleischmann R et al. Phase IIb dose-ranging study of the oral JAK inhibitor tofacitinib (CP-690,550) or adalimumab monotherapy versus placebo in patients with active rheumatoid arthritis with an inadequate response to disease-modifying antirheumatic drugs. *Arthritis Rheum* 2012 64:(3) 624-629.
2. Ghoreschi K, Jesson MI, Li X, et al. Modulation of Innate and Adaptive Immune Responses by Tofacitinib (CP-690,550). *J Immunol* 2011;186(7):4234-43.
3. Gupta P J. A semi-mechanistic model of CP-690,550-induced reduction in neutrophil counts in patients with rheumatoid arthritis. *Clin Pharmacol*. 2010 Jun; 50(6):679-87. Epub 2009 Oct 30.
4. Karaman MW, Herrgard S, Treiber DK, et al. A quantitative analysis of kinase inhibitor selectivity. *Nat Biotechnol* 2008;26:127-32.
5. Kremer JM et al. The safety and efficacy of a JAK inhibitor in patients with active rheumatoid arthritis: Results of a double-blind, placebo-controlled phase IIa trial of three dosage levels of CP-690,550 versus placebo. *Arthritis Rheum* 2009 60:(7): 1895-1905.
6. Kremer JM et al. A Phase 2B dose-ranging study of the oral JAK inhibitor tofacitinib (CP-690,550) versus placebo in combination with background methotrexate in patients with active rheumatoid arthritis and inadequate response to methotrexate alone. *Arthritis Rheum* 2011Oct e-pub.
7. Meyer DM, Jesson MI. Anti-inflammatory activity and neutrophil reductions mediated by the JAK1/JAK3 inhibitor, CP-690,550, in rat adjuvant-induced arthritis. *J Inflamm (Lond)* 2010;7:41.
8. Russell S, Tayebi N, Nakajima H, et al. Mutation of JAK3 in a patient with SCID: essential role of JAK3 in lymphoid development. *Science* 1995;270:797-800.
9. Thomis D, Berg L. The role of JAK3 in lymphoid development, activation, and signaling. *Curr Opin Immunol* 1997;9:541-7.
10. Walker J, Smith M. The JAK/STAT Pathway in Rheumatoid Arthritis. *J Rheum* 2005; 32(9):1650-3.
11. Van Vollenhoven RF, Fleischmann R, Cohen S, Lee EB, Garcia Mejjide JA, Wagner S, et al. Tofacitinib or adalimumab versus placebo in rheumatoid arthritis. *N Engl J Med* 2012;367:508-19.

PART III: CONSUMER INFORMATION

Pr XELJANZ[®]
Tofacitinib tablets

Pr XELJANZ[®] XR
Tofacitinib extended-release tablets

This leaflet is part III of a three-part "Product Monograph" published when XELJANZ/XELJANZ XR was approved for sale in Canada and is designed specifically for Consumers. This leaflet is a summary and will not tell you everything about XELJANZ/XELJANZ XR. Contact your doctor or pharmacist if you have any questions about the drug.

ABOUT THIS MEDICATION

What the medication is used for:

Rheumatoid Arthritis

XELJANZ/XELJANZ XR (tofacitinib) is used to treat rheumatoid arthritis (RA) when other treatments do not work.

Psoriatic Arthritis

XELJANZ is used to treat active psoriatic arthritis (PsA) when other medicines do not work.

Ulcerative Colitis

XELJANZ is used to treat moderately to severely active ulcerative colitis (UC) when other medicines do not work

What it does:

XELJANZ/XELJANZ XR is believed to interfere with the activity of an enzyme called Janus kinase (JAK), which activates other cellular components which normally start the immune response in your body. By reducing the immune response XELJANZ/XELJANZ XR reduces the signs and symptoms of rheumatoid arthritis and psoriatic arthritis. XELJANZ also reduces the sign and symptoms of ulcerative colitis.

When it should not be used:

- If you are allergic to tofacitinib or any other non-medicinal ingredients in XELJANZ/XELJANZ XR, you should not take XELJANZ/XELJANZ XR (see **What the non-medicinal ingredients are**).
- Do not take this medication if you are pregnant or are planning to become pregnant.
- Do not take this medication if you are breast-feeding or intend to breast-feed. Talk to your doctor about how to feed your child while taking XELJANZ/XELJANZ XR.
- Do not take this medication if you have a severe liver insufficiency.

What the medicinal ingredient is:

The active ingredient of XELJANZ/XELJANZ XR is called tofacitinib citrate

What the non-medicinal ingredients are:

XELJANZ:

The 5 mg tablet core contains: Croscarmellose Sodium, Lactose Monohydrate, Magnesium Stearate, Microcrystalline Cellulose. The film coat contains HPMC 2910/Hypromellose 6 cP, Lactose Monohydrate, Macrogol/PEG 3350, Titanium dioxide, Triacetin (Glycerol Triacetate)

The 10 mg tablet core contains: Microcrystalline Cellulose, Lactose Monohydrate, croscarmellose Sodium, Magnesium Stearate. The film coat contains: HPMC 2910/Hypromellose 6cP, titanium dioxide, lactose monohydrate, macrogol/PEG3350, triacetin (glycerol triacetate), FD&C blue #2/indigo carmine aluminum lake, FD&C blue #1/brilliant blue FCF aluminum lake.

XELJANZ XR: ammonium hydroxide, cellulose acetate, copovidone, ferrousferic oxide/black iron oxide, hydroxyethyl cellulose, hydroxypropyl cellulose, HPMC 2910/hypromellose, magnesium stearate, propylene glycol, red iron oxide, shellac glaze, sorbitol, titanium dioxide, triacetin.

What dosage forms it comes in:

XELJANZ is supplied as 5 mg and 10 mg tablets and is available in bottles or foil blisters.

XELJANZ XR is supplied as 11 mg tablets and is available in bottles.

WARNINGS AND PRECAUTIONS

Serious Warning and Precautions

- XELJANZ/XELJANZ XR is a medicine that affects your immune system and can lower the ability of your body to fight infections such as tuberculosis, and infections caused by other bacteria, fungi, or viruses that can spread throughout the body. These infections may lead to hospitalization or death. Most patients who developed these infections were taking other medicines that make it harder to fight infections at the same time such as methotrexate or corticosteroids. You should not be using XELJANZ/ XELJANZ XR if you have any kind of infection.
- If a serious infection develops, stop XELJANZ/XELJANZ XR and contact your doctor.
- Your doctor will closely monitor you for the signs and symptoms of infection during and after the treatment with XELJANZ/ XELJANZ XR.
- Lymphoma, other cancers and other serious conditions have been reported in patients treated with XELJANZ

Blood Clots

- Blood clots in the veins of your legs or arms (deep vein thrombosis, DVT), arteries (arterial thrombosis) or lungs (pulmonary embolism, PE) can happen in some people taking XELJANZ. This may be life-threatening and cause death.

- If you develop any signs or symptoms of a blood clot in your leg (such as swelling, pain or tenderness in the leg) or in your lung (such as sudden unexplained chest pain or shortness of breath) stop XELJANZ and seek immediate medical help.

BEFORE or while taking XELJANZ or XELJANZ XR, tell your healthcare professional if you:

- think you have an infection or have symptoms of an infection such as:
 - fever, sweating, or chills,
 - muscle aches,
 - cough,
 - shortness of breath,
 - blood in spit,
 - weight loss,
 - warm, red, or painful skin or sores on your body,
 - diarrhea or stomach pain,
 - burning when you urinate or urinating more often than normal,
 - feeling very tired;
- are being treated for an infection, get a lot of infections or have infections that keep coming back;
- have diabetes, HIV/AIDS, or a weak immune system. People with these conditions have a higher chance for infections;
- have tuberculosis, or a history of tuberculosis or have been in close contact with someone with tuberculosis;
- have or have had hepatitis B or C;
- have gastrointestinal perforations (tear in the stomach or intestines);
- have diverticulitis (inflammation in parts of the large intestine);
- have ulcers in your stomach or intestines;
- have low blood counts: treatment with XELJANZ/XELJANZ XR can be associated with low red blood cell counts (anemia), or with low white blood cell counts (neutrophils or lymphocytes). Your healthcare professional will monitor your blood counts regularly after you start XELJANZ/XELJANZ XR, and may adjust your dose of XELJANZ/XELJANZ XR or withhold the drug temporarily in the event your blood counts drops too low, or administer additional supportive medicines to help your body regain normal blood cell levels;
- have high cholesterol. Your healthcare professional should monitor your liver tests and blood cholesterol levels 4-8 weeks after you start receiving XELJANZ/XELJANZ XR and routinely thereafter;
- have or had any type of cancer;
- have liver or kidney problems;
- have a history of interstitial lung disease;
- have muscle pain or muscle weakness;
- develop new skin lesions during or after therapy or if existing lesions change appearance;
- are planning to get vaccinated. Certain types of vaccines (shots) should not be given when taking XELJANZ/XELJANZ XR. Before you start XELJANZ/XELJANZ XR, you should be up to date with all recommended vaccinations, including a shingles vaccine;
- have chest pain or any heart problems;

- are over the age of 65 or of Asian descent, you may be at increased risk of serious side effects.
- have had blood clots in your legs (deep vein thrombosis) or lungs (pulmonary embolism) or have been told you are at risk of blood clots. Blood clots in the legs and lungs can happen in some people taking XELJANZ. This may be life-threatening and cause death. If you have any signs or symptoms of blood clots while you are being treated with XELJANZ, including swelling, pain or tenderness in the leg, sudden unexplained chest pain, or shortness of breath, stop XELJANZ and seek immediate medical help.
- have problems with your blood clotting (thrombophilia)
- have chest pain
- have heart failure or any heart problems

BEFORE or while taking XELJANZ XR, tell your doctor if you have known narrowing or blockage of your digestive tract (intestines or another part of your bowel are not as wide as normal).

If you are of child-bearing age, you should use an effective method of birth control while taking XELJANZ/XELJANZ XR and for 4 to 6 weeks after you stop taking XELJANZ/XELJANZ XR.

INTERACTIONS WITH THIS MEDICATION

It is important that your healthcare professional be aware of all medications you are taking prior to starting XELJANZ/XELJANZ XR including biologics such as Cimzia™, Cosentyx®, Enbrel®, Humira®, Kineret®, Orencia®, Remicade®, Rituxan®, Entyvio®, Simponi™ and Stelara®.

- Tell your doctor if you are taking immunosuppressants (e.g. azathioprine, 6-mercaptopurine, tacrolimus, sirolimus, cyclosporine), antiarrhythmics, beta-blockers, calcium channel blockers, cholinesterase inhibitors, HIV protease inhibitors, rifampin, ketoconazole, fluconazole.
- Tell your doctor if you have received any vaccines (shots) within 1 month prior to starting XELJANZ /XELJANZ XR.
- Avoid grapefruit juice.
- St. John's Wort (an herbal medicine also known as hypericum perforatum) may reduce the response to XELJANZ/XELJANZ XR.

PROPER USE OF THIS MEDICATION

XELJANZ/XELJANZ XR can be taken with or without food.

Your doctor may reduce the dose if you have liver or kidney problems. You should not increase the dose.

XELJANZ/XELJANZ XR should not be used if you have or develop a serious infection until the infection is controlled.

Usual adult dose:

Rheumatoid Arthritis:

- The recommended dose of XELJANZ is 5 mg taken by mouth twice daily.
- The recommended dose of XELJANZ XR is 11 mg taken by mouth once daily. Swallow XELJANZ XR tablets whole. Do not crush, split or chew the tablets.
- Patients taking XELJANZ/XELJANZ XR are usually also prescribed methotrexate.

Psoriatic Arthritis:

- The recommended dose of XELJANZ is 5 mg taken by mouth twice daily.
- Patients taking XELJANZ are also prescribed methotrexate or another conventional synthetic DMARD (csDMARD).

Ulcerative Colitis:

- The recommended dose of XELJANZ is 10 mg twice daily for the first 8 weeks. After 8 weeks, your doctor will decide to give you 5 mg or 10 mg twice daily for maintenance.
- Your doctor may decide to stop XELJANZ if XELJANZ does not work for you within 16 weeks.
- XELJANZ may be used together with certain other medicines, such as corticosteroids and aminosalicylates to treat ulcerative colitis.

Overdose

In case of a drug overdose, contact a health care practitioner, hospital emergency department or regional Poison Control Centre immediately, even if there are no symptoms.

Missed Dose:

If you have missed your dose of XELJANZ/XELJANZ XR, take the next dose as planned at the next scheduled time. Do not take a double dose to make up for a forgotten dose.

SIDE EFFECTS AND WHAT TO DO ABOUT THEM

These are not all the possible side effects you may feel when taking XELJANZ/XELJANZ XR. If you experience any side effects not listed here, contact your healthcare professional.

The side effects of XELJANZ/XELJANZ XR include:

- Upper respiratory tract infection (such as a cold)
- Nasopharyngitis (nose or throat infection runny or stuffy nose)
- Headache
- Diarrhea
- Nausea (feeling queasy, feeling like you may throw up)
- Indigestion (heartburn or upset stomach)
- Cough
- Dizziness
- Vomiting
- Back pain
- Joint pain
- Rash
- Muscle weakness/pain

If any of the above affects you severely, tell your doctor or pharmacist.

XELJANZ/XELJANZ XR may cause abnormal blood test results, including changes in cholesterol levels, white or red blood cell counts or creatinine levels (a protein that may increase in people with kidney problems). Your doctor will decide when to perform blood tests and will interpret the results.

SERIOUS SIDE EFFECTS, HOW OFTEN THEY HAPPEN AND WHAT TO DO ABOUT THEM			
Symptom / effect	Talk with your healthcare professional		Stop taking drug and get immediate medical help
	Only if severe	In all cases	
COMMON			
Pneumonia: infection with coughing, fever, fatigue		✓	
Urinary tract infections: difficulty or increased need to urinate, pain or burning sensation when passing urine, pain in the pelvis or mid-back, urine that appears cloudy		✓	
High blood pressure		✓	
Gastritis: abdominal pain, loss of appetite		✓	
Shingles/Herpes Zoster: skin rash or blisters usually on one side of the body with itching, burning or tingling pain			✓
Cellulitis: skin infection with redness, swelling and painful skin		✓	
UNCOMMON			
Blood clot in the leg (deep vein thrombosis): swelling, pain or tenderness in the leg			✓
Blood clot in the lung (pulmonary embolism): chest pain, or shortness of breath			✓

SERIOUS SIDE EFFECTS, HOW OFTEN THEY HAPPEN AND WHAT TO DO ABOUT THEM

Symptom / effect	Talk with your healthcare professional		Stop taking drug and get immediate medical help
	Only if severe	In all cases	
Bronchitis: persistent cough, fatigue, shortness of breath		✓	
Flu: cough, sore throat, feverish chills		✓	
Skin cancer: lesions during or after therapy or if existing lesions change appearance		✓	
Increased creatine kinase levels: muscle weakness and/or muscle pain	✓		
Kidney problems: change in the amount, frequency or colour (pale or dark) of urine		✓	
Liver problems: yellowing of the skin or eyes, dark urine, abdominal pain, nausea, throwing up, loss of appetite with itching			✓
Low blood cell counts (anemia/neutropenia/lymphopenia): fatigue, loss of energy, weakness, shortness of breath		✓	
Peripheral edema: swelling of legs and ankles or the arms and hands		✓	
Congestive heart failure: shortness of breath when you exert yourself or lie down, swelling in your legs, ankles and feet, irregular heartbeat, persistent cough			✓

SERIOUS SIDE EFFECTS, HOW OFTEN THEY HAPPEN AND WHAT TO DO ABOUT THEM

Symptom / effect	Talk with your healthcare professional		Stop taking drug and get immediate medical help
	Only if severe	In all cases	
Allergic reaction: hives, rash, swelling of the face, lips, tongue, and throat that may cause difficulty in breathing or swallowing			✓

If you have a troublesome symptom or side effect that is not listed here or becomes bad enough to interfere with your daily activities, talk to your healthcare professional.

HOW TO STORE IT

Store between 15°C and 30°C.
Keep out of sight and reach of children.

REPORTING SIDE EFFECTS

You can report any suspected side effects associated with the use of health products to Health Canada by:

- Visiting the Web page on Adverse Reaction Reporting (<https://www.canada.ca/en/health-canada/services/drugs-health-products/medeffect-canada/adverse-reaction-reporting.html>) for information on how to report online, by mail or by fax; or
- Calling toll-free at 1-866-234-2345.

NOTE: Contact your health professional if you need information about how to manage your side effects. The Canada Vigilance Program does not provide medical advice.

MORE INFORMATION

If you want more information about XELJANZ/ XELJANZ XR:

- Talk to your healthcare professional;
- Find the full product monograph that is prepared for healthcare professionals and includes this Patient Medication Information by visiting the Health Canada Website (<https://www.canada.ca/en/health-canada.html>), the manufacturer's website (<http://www.Pfizer.ca>) or by calling the sponsor, Pfizer Canada ULC, at 1-800-463-6001.

This leaflet was prepared by Pfizer Canada ULC

Last revised: October 24, 2019

HIGHLIGHTS OF PRESCRIBING INFORMATION

These highlights do not include all the information needed to use XELJANZ/XELJANZ XR safely and effectively. See full prescribing information for XELJANZ/XELJANZ XR.

XELJANZ® (tofacitinib) tablets, for oral use
XELJANZ® XR (tofacitinib) extended-release tablets, for oral use
Initial U.S. Approval: 2012

WARNING: SERIOUS INFECTIONS, MORTALITY, MALIGNANCY AND THROMBOSIS

See full prescribing information for complete boxed warning.

- Serious infections leading to hospitalization or death, including tuberculosis and bacterial, invasive fungal, viral, and other opportunistic infections, have occurred. (5.1)
- If a serious infection develops, interrupt XELJANZ/XELJANZ XR until the infection is controlled. (5.1)
- Prior to starting XELJANZ/XELJANZ XR, perform a test for latent tuberculosis; if it is positive, start treatment for tuberculosis prior to starting XELJANZ/XELJANZ XR. (5.1)
- Monitor all patients for active tuberculosis during treatment, even if the initial latent tuberculosis test is negative. (5.1)
- Thrombosis, including pulmonary embolism, deep venous thrombosis and arterial thrombosis have occurred in patients treated with XELJANZ and other Janus kinase inhibitors. Rheumatoid arthritis patients with at least one cardiovascular (CV) risk factor had a higher rate of all-cause mortality and thrombosis with XELJANZ 10 mg twice daily vs. 5 mg twice daily or TNF blockers. (5.2, 5.4)
- Lymphoma and other malignancies have been observed in patients treated with XELJANZ, including an increased rate of Epstein Barr Virus-associated post-transplant lymphoproliferative disorder. (5.3)

RECENT MAJOR CHANGES

Boxed Warning	07/2019
Indications and Usage (1)	12/2019
Dosage and Administration (2.2)	12/2019
Dosage and Administration (2.3)	12/2019
Warnings and Precautions (5.2)	07/2019
Warnings and Precautions (5.4)	07/2019

INDICATIONS AND USAGE

XELJANZ/XELJANZ XR is a Janus kinase (JAK) inhibitor.

- **Rheumatoid Arthritis:** XELJANZ/XELJANZ XR is indicated for the treatment of adult patients with moderately to severely active rheumatoid arthritis who have had an inadequate response or intolerance to methotrexate. It may be used as monotherapy or in combination with methotrexate or other nonbiologic disease-modifying antirheumatic drugs (DMARDs).
 - **Limitations of Use:** Use of XELJANZ/XELJANZ XR in combination with biologic DMARDs or potent immunosuppressants such as azathioprine and cyclosporine is not recommended. (1)
- **Psoriatic Arthritis:** XELJANZ/XELJANZ XR is indicated for the treatment of adult patients with active psoriatic arthritis who have had an inadequate response or intolerance to methotrexate or other disease-modifying antirheumatic drugs (DMARDs).
 - **Limitations of Use:** Use of XELJANZ/XELJANZ XR in combination with biologic DMARDs or potent immunosuppressants such as azathioprine and cyclosporine is not recommended. (1)
- **Ulcerative Colitis:** XELJANZ/XELJANZ XR is indicated for the treatment of adult patients with moderately to severely active ulcerative colitis (UC), who have had an inadequate response or who are intolerant to TNF blockers.
 - **Limitations of Use:** Use of XELJANZ/XELJANZ XR in combination with biological therapies for UC or with potent immunosuppressants such as azathioprine and cyclosporine is not recommended. (1)

DOSAGE AND ADMINISTRATION

Administration Instructions

- Do not initiate XELJANZ/XELJANZ XR if absolute lymphocyte count <500 cells/mm³, an absolute neutrophil count (ANC) <1000 cells/mm³ or hemoglobin <9 g/dL. (2.1)

Recommended Dosage

Rheumatoid Arthritis

- XELJANZ 5 mg twice daily or XELJANZ XR 11 mg once daily. (2.2)
- Recommended dosage in patients with moderate and severe renal impairment or moderate hepatic impairment is XELJANZ 5 mg once daily. (2, 8.7, 8.8)

Psoriatic Arthritis (in combination with nonbiologic DMARDs)

- XELJANZ 5 mg twice daily or XELJANZ XR 11 mg once daily. (2.2)
- Recommended dosage in patients with moderate and severe renal impairment or moderate hepatic impairment is XELJANZ 5 mg once daily. (2, 8.7, 8.8)

Ulcerative Colitis

- Induction: XELJANZ 10 mg twice daily or XELJANZ XR 22 mg once daily for 8 weeks; evaluate patients and transition to maintenance therapy depending on therapeutic response. If needed, continue XELJANZ 10 mg twice daily or XELJANZ XR 22 mg once daily for a maximum of 16 weeks. Discontinue XELJANZ 10 mg twice daily or XELJANZ XR 22 mg once daily after 16 weeks if adequate therapeutic response is not achieved. (2.3)
- Maintenance: XELJANZ 5 mg twice daily or XELJANZ XR 11 mg once daily. For patients with loss of response during maintenance treatment, XELJANZ 10 mg twice daily or XELJANZ XR 22 mg once daily may be considered and limited to the shortest duration, with careful consideration of the benefits and risks for the individual patient. Use the lowest effective dose needed to maintain response. (2.3)
- Dosage adjustment is needed in patients with moderate and severe renal impairment or moderate hepatic impairment: see full prescribing information. (2.3)

Dosage Adjustment

- See the full prescribing information for dosage adjustments by indication for patients receiving CYP2C19 and/or CYP3A4 inhibitors; in patients with moderate or severe renal impairment or moderate hepatic impairment; and patients with lymphopenia, neutropenia, or anemia. (2.2, 2.3, 8.7, 8.8)
- Use of XELJANZ/XELJANZ XR in patients with severe hepatic impairment is not recommended in any patient population. (2.2, 2.3, 8.8)

DOSAGE FORMS AND STRENGTHS

XELJANZ Tablets: 5 mg, 10 mg tofacitinib (3)

XELJANZ XR Tablets: 11 mg, 22 mg tofacitinib (3)

CONTRAINDICATIONS

None (4)

WARNINGS AND PRECAUTIONS

- **Serious Infections:** Avoid use of XELJANZ/XELJANZ XR during an active serious infection, including localized infections. (5.1)
- **Thrombosis, including pulmonary, deep venous and arterial, some fatal:** Reported more commonly in patients treated with XELJANZ 10 mg twice daily compared to 5 mg twice daily. Avoid XELJANZ/XELJANZ XR in patients at risk. Promptly evaluate patients with symptoms of thrombosis and discontinue XELJANZ/XELJANZ XR. (5.4)
- **Gastrointestinal Perforations:** Use with caution in patients that may be at increased risk. (5.5)
- **Laboratory Monitoring:** Recommended due to potential changes in lymphocytes, neutrophils, hemoglobin, liver enzymes and lipids. (5.7)
- **Immunizations:** Live vaccines: Avoid use with XELJANZ/XELJANZ XR. (5.8)

ADVERSE REACTIONS

Most common adverse reactions are:

- **Rheumatoid and Psoriatic Arthritis:** Reported during the first 3 months in rheumatoid arthritis controlled clinical trials and occurring in ≥2% of patients treated with XELJANZ monotherapy or in combination with DMARDs: upper respiratory tract infection, nasopharyngitis, diarrhea, and headache. (6.1)
- **Ulcerative Colitis:** Reported in ≥5% of patients treated with either 5 mg or 10 mg twice daily of XELJANZ and ≥1% greater than reported in patients receiving placebo in either the induction or maintenance clinical trials: nasopharyngitis, elevated cholesterol levels, headache, upper respiratory tract infection, increased blood creatine phosphokinase, rash, diarrhea, and herpes zoster. (6.1)

To report SUSPECTED ADVERSE REACTIONS, contact Pfizer, Inc. at 1-800-438-1985 or FDA at 1-800-FDA-1088 or www.fda.gov/medwatch.

DRUG INTERACTIONS

See full prescribing information for clinically relevant drug interactions. (2, 7)

USE IN SPECIFIC POPULATIONS

Lactation: Advise not to breastfeed. (8.2)

See 17 for PATIENT COUNSELING INFORMATION and Medication Guide.

Revised: 12/2019

FULL PRESCRIBING INFORMATION: CONTENTS*

**WARNING: SERIOUS INFECTIONS, MORTALITY,
MALIGNANCY AND THROMBOSIS**

1 INDICATIONS AND USAGE

2 DOSAGE AND ADMINISTRATION

- 2.1 Important Administration Instructions
- 2.2 Recommended Dosage in Rheumatoid Arthritis and Psoriatic Arthritis
- 2.3 Recommended Dosage in Ulcerative Colitis

3 DOSAGE FORMS AND STRENGTHS

4 CONTRAINDICATIONS

5 WARNINGS AND PRECAUTIONS

- 5.1 Serious Infections
- 5.2 Mortality
- 5.3 Malignancy and Lymphoproliferative Disorders
- 5.4 Thrombosis
- 5.5 Gastrointestinal Perforations
- 5.6 Hypersensitivity
- 5.7 Laboratory Abnormalities
- 5.8 Vaccinations
- 5.9 Risk of Gastrointestinal Obstruction with a Non-Deformable Extended-Release Formulation such as XELJANZ XR

6 ADVERSE REACTIONS

- 6.1 Clinical Trials Experience
- 6.2 Postmarketing Experience

7 DRUG INTERACTIONS

8 USE IN SPECIFIC POPULATIONS

- 8.1 Pregnancy
- 8.2 Lactation
- 8.3 Females and Males of Reproductive Potential
- 8.4 Pediatric Use
- 8.5 Geriatric Use
- 8.6 Use in Diabetics
- 8.7 Renal Impairment
- 8.8 Hepatic Impairment

10 OVERDOSAGE

11 DESCRIPTION

12 CLINICAL PHARMACOLOGY

- 12.1 Mechanism of Action
- 12.2 Pharmacodynamics
- 12.3 Pharmacokinetics

13 NONCLINICAL TOXICOLOGY

- 13.1 Carcinogenesis, Mutagenesis, Impairment of Fertility

14 CLINICAL STUDIES

- 14.1 Rheumatoid Arthritis
- 14.2 Psoriatic Arthritis
- 14.3 Ulcerative Colitis

16 HOW SUPPLIED/STORAGE AND HANDLING

17 PATIENT COUNSELING INFORMATION

*Sections or subsections omitted from the Full Prescribing Information are not listed.

FULL PRESCRIBING INFORMATION

WARNING: SERIOUS INFECTIONS, MORTALITY, MALIGNANCY AND THROMBOSIS

SERIOUS INFECTIONS

Patients treated with XELJANZ/XELJANZ XR are at increased risk for developing serious infections that may lead to hospitalization or death [see *Warnings and Precautions (5.1), Adverse Reactions (6.1)*]. Most patients who developed these infections were taking concomitant immunosuppressants such as methotrexate or corticosteroids.

If a serious infection develops, interrupt XELJANZ/XELJANZ XR until the infection is controlled.

Reported infections include:

- Active tuberculosis, which may present with pulmonary or extrapulmonary disease. Patients should be tested for latent tuberculosis before XELJANZ/XELJANZ XR use and during therapy. Treatment for latent infection should be initiated prior to XELJANZ/XELJANZ XR use.
- Invasive fungal infections, including cryptococcosis and pneumocystosis. Patients with invasive fungal infections may present with disseminated, rather than localized, disease.
- Bacterial, viral, including herpes zoster, and other infections due to opportunistic pathogens.

The risks and benefits of treatment with XELJANZ/XELJANZ XR should be carefully considered prior to initiating therapy in patients with chronic or recurrent infection.

Patients should be closely monitored for the development of signs and symptoms of infection during and after treatment with XELJANZ/XELJANZ XR, including the possible development of tuberculosis in patients who tested negative for latent tuberculosis infection prior to initiating therapy [see *Warnings and Precautions (5.1)*].

MORTALITY

Rheumatoid arthritis patients 50 years of age and older with at least one cardiovascular (CV) risk factor treated with XELJANZ 10 mg twice a day had a higher rate of all-cause mortality, including sudden CV death, compared to those treated with XELJANZ 5 mg given twice daily or TNF blockers in a large, ongoing, postmarketing safety study [see *Warnings and Precautions (5.2)*].

MALIGNANCIES

Lymphoma and other malignancies have been observed in patients treated with XELJANZ. Epstein Barr Virus-associated post-transplant lymphoproliferative disorder has been observed at an increased rate in renal transplant patients treated with XELJANZ and concomitant immunosuppressive medications [see *Warnings and Precautions (5.3)*].

THROMBOSIS

Thrombosis, including pulmonary embolism, deep venous thrombosis, and arterial thrombosis have occurred in patients treated with XELJANZ and other Janus kinase inhibitors used to treat inflammatory conditions. Rheumatoid arthritis patients who were 50 years of age and older with at least one CV risk factor treated with XELJANZ 10 mg twice daily compared to XELJANZ 5 mg twice daily or TNF blockers in a large, ongoing postmarketing safety study had an observed increase in incidence of these events. Many of these events were serious and some resulted in death. Avoid XELJANZ/XELJANZ XR in patients at risk. Discontinue XELJANZ/XELJANZ XR and promptly evaluate patients with symptoms of thrombosis [see Warnings and Precautions (5.4)].

For patients with ulcerative colitis, use XELJANZ at the lowest effective dose and for the shortest duration needed to achieve/maintain therapeutic response [see Dosage and Administration (2.3)].

1 INDICATIONS AND USAGE

Rheumatoid Arthritis

XELJANZ/XELJANZ XR is indicated for the treatment of adult patients with moderately to severely active rheumatoid arthritis (RA) who have had an inadequate response or intolerance to methotrexate. It may be used as monotherapy or in combination with methotrexate or other nonbiologic disease-modifying antirheumatic drugs (DMARDs).

- Limitations of Use: Use of XELJANZ/XELJANZ XR in combination with biologic DMARDs or with potent immunosuppressants such as azathioprine and cyclosporine is not recommended.

Psoriatic Arthritis

XELJANZ/XELJANZ XR is indicated for the treatment of adult patients with active psoriatic arthritis (PsA) who have had an inadequate response or intolerance to methotrexate or other disease-modifying antirheumatic drugs (DMARDs).

- Limitations of Use: Use of XELJANZ/XELJANZ XR in combination with biologic DMARDs or with potent immunosuppressants such as azathioprine and cyclosporine is not recommended.

Ulcerative Colitis

XELJANZ/XELJANZ XR is indicated for the treatment of adult patients with moderately to severely active ulcerative colitis (UC), who have an inadequate response or who are intolerant to TNF blockers.

- Limitations of Use: Use of XELJANZ/XELJANZ XR in combination with biological therapies for UC or with potent immunosuppressants such as azathioprine and cyclosporine is not recommended.

2 DOSAGE AND ADMINISTRATION

2.1 Important Administration Instructions

- Do not initiate XELJANZ/XELJANZ XR in patients with an absolute lymphocyte count less than 500 cells/mm³, an absolute neutrophil count (ANC) less than 1000 cells/mm³ or who have hemoglobin levels less than 9 g/dL.
- Dose interruption is recommended for management of lymphopenia, neutropenia, and anemia [see Warnings and Precautions (5.7), Adverse Reactions (6.1)].
- Interrupt use of XELJANZ/XELJANZ XR if a patient develops a serious infection until the infection is controlled [see Warnings and Precautions (5.1)].
- Take XELJANZ/XELJANZ XR with or without food [see Clinical Pharmacology (12.3)].
- Swallow XELJANZ XR tablets whole and intact. Do not crush, split, or chew.

2.2 Recommended Dosage in Rheumatoid Arthritis and Psoriatic Arthritis

Table 1 displays the recommended adult daily dosage of XELJANZ and XELJANZ XR and dosage adjustments for patients receiving CYP2C19 and/or CYP3A4 inhibitors, in patients with moderate or severe renal impairment (including but not limited to those with severe insufficiency who are undergoing hemodialysis) or moderate hepatic impairment, with lymphopenia, neutropenia, or anemia.

Table 1: Recommended Dosage of XELJANZ and XELJANZ XR in Patients with Rheumatoid Arthritis¹ and Psoriatic Arthritis²

	XELJANZ	XELJANZ XR
Adult patients	5 mg twice daily	11 mg once daily
Patients receiving: <ul style="list-style-type: none"> • Strong CYP3A4 inhibitors (e.g., ketoconazole), or • a moderate CYP3A4 inhibitor(s) with a strong CYP2C19 inhibitor(s) (e.g., fluconazole) [see Drug Interactions (7)]	5 mg once daily	Reduce to XELJANZ 5 mg once daily
Patients with: <ul style="list-style-type: none"> • moderate or severe renal impairment [see Use in Specific Populations (8.7)] • moderate hepatic impairment [see Use in Specific Populations (8.8)]* 	5 mg once daily	Reduce to XELJANZ 5 mg once daily
	For patients undergoing hemodialysis, dose should be administered after the dialysis session on dialysis days. If a dose was taken before the dialysis procedure, supplemental doses are not recommended in patients after dialysis.	

	XELJANZ	XELJANZ XR
Patients with lymphocyte count less than 500 cells/mm ³ , confirmed by repeat testing	Discontinue dosing.	
Patients with ANC 500 to 1000 cells/mm ³	Interrupt dosing. When ANC is greater than 1000, resume 5 mg twice daily.	Interrupt dosing. When ANC is greater than 1000, resume 11 mg once daily.
Patients with ANC less than 500 cells/mm ³	Discontinue dosing.	
Patients with hemoglobin less than 8 g/dL or a decrease of more than 2 g/dL	Interrupt dosing until hemoglobin values have normalized.	

¹ XELJANZ/XELJANZ XR may be used as monotherapy or in combination with methotrexate or other nonbiologic disease-modifying antirheumatic drugs (DMARDs) in rheumatoid arthritis.

² XELJANZ/XELJANZ XR is used in combination with nonbiologic disease modifying antirheumatic drugs (DMARDs) in psoriatic arthritis. The efficacy of XELJANZ/XELJANZ XR as a monotherapy has not been studied in psoriatic arthritis.

* Use of XELJANZ/XELJANZ XR in patients with severe hepatic impairment is not recommended.

Switching from XELJANZ Tablets to XELJANZ XR Tablets

Patients treated with XELJANZ 5 mg twice daily may be switched to XELJANZ XR 11 mg once daily the day following the last dose of XELJANZ 5 mg.

2.3 Recommended Dosage in Ulcerative Colitis

Table 2 displays the recommended adult daily dosage of XELJANZ/XELJANZ XR and dosage adjustments for patients receiving CYP2C19 and/or CYP3A4 inhibitors, with moderate or severe renal impairment (including but not limited to those with severe insufficiency who are undergoing hemodialysis) or moderate hepatic impairment, with lymphopenia, neutropenia or anemia.

Table 2: Recommended Dosage of XELJANZ/XELJANZ XR in Patients with UC

--

	XELJANZ	XELJANZ XR
Adult patients	<p>Induction: 10 mg twice daily for at least 8 weeks [see <i>Clinical Studies (14.3)</i>]; evaluate patients and transition to maintenance therapy depending on therapeutic response. If needed continue 10 mg twice daily for a maximum of 16 weeks. Discontinue 10 mg twice daily after 16 weeks if adequate therapeutic response is not achieved.</p> <p>Maintenance: 5 mg twice daily.</p> <p>For patients with loss of response during maintenance treatment, a dosage of 10 mg twice daily may be considered and limited to the shortest duration, with careful consideration of the benefits and risks for the individual patient. Use the lowest effective dose needed to maintain response.</p>	<p>Induction: 22 mg once daily for at least 8 weeks; evaluate patients and transition to maintenance therapy depending on therapeutic response. If needed continue 22 mg once daily for a maximum of 16 weeks. Discontinue 22 mg once daily after 16 weeks if adequate therapeutic response is not achieved.</p> <p>Maintenance: 11 mg once daily.</p> <p>For patients with loss of response during maintenance treatment, a dosage of 22 mg once daily may be considered and limited to the shortest duration, with careful consideration of the benefits and risks for the individual patient. Use the lowest effective dose needed to maintain response.</p>
Patients receiving: <ul style="list-style-type: none"> • Strong CYP3A4 inhibitors (e.g., ketoconazole), or • a moderate CYP3A4 inhibitor(s) with a strong CYP2C19 inhibitor(s) (e.g., fluconazole) [see <i>Drug Interactions (7)</i>]	<p>If taking 10 mg twice daily, reduce to 5 mg twice daily.</p> <p>If taking 5 mg twice daily, reduce to 5 mg once daily.</p>	<p>If taking 22 mg once daily, reduce to 11 mg once daily.</p> <p>If taking 11 mg once daily, reduce to XELJANZ 5 mg once daily</p>
Patients with: <ul style="list-style-type: none"> • moderate or severe renal impairment [see <i>Use in Specific Populations (8.7)</i>] • moderate hepatic impairment [see <i>Use in Specific Populations (8.8)</i>]* 	<p>If taking 10 mg twice daily, reduce to 5 mg twice daily.</p> <p>If taking 5 mg twice daily, reduce to 5 mg once daily.</p>	<p>If taking 22 mg once daily, reduce to 11 mg once daily.</p> <p>If taking 11 mg once daily, reduce to XELJANZ 5 mg once daily.</p>
Patients with lymphocyte count less than 500 cells/mm ³ , confirmed by repeat testing	Discontinue dosing	

	XELJANZ	XELJANZ XR
Patients with ANC 500 to 1000 cells/mm ³	If taking 10 mg twice daily, reduce to 5 mg twice daily. When ANC is greater than 1000, increase to 10 mg twice daily based on clinical response. If taking 5 mg twice daily, interrupt dosing. When ANC is greater than 1000, resume 5 mg twice daily.	If taking 22 mg once daily, reduce to 11 mg once daily. When ANC is greater than 1000, increase to 22 mg once daily based on clinical response. If taking 11 mg once daily, interrupt dosing. When ANC is greater than 1000, resume 11 mg once daily.
Patients with ANC less than 500 cells/mm ³	Discontinue dosing.	
Patients with hemoglobin less than 8 g/dL or a decrease of more than 2 g/dL	Interrupt dosing until hemoglobin values have normalized.	

*Use of XELJANZ/XELJANZ XR in patients with severe hepatic impairment is not recommended.

Switching from XELJANZ Tablets to XELJANZ XR Tablets

Patients treated with XELJANZ 5 mg twice daily may be switched to XELJANZ XR 11 mg once daily the day following the last dose of XELJANZ 5 mg. Patients treated with XELJANZ 10 mg twice daily may be switched to XELJANZ XR 22 mg once daily the day following the last dose of XELJANZ 10 mg.

3 DOSAGE FORMS AND STRENGTHS

XELJANZ Tablets:

- 5 mg tofacitinib: White, round, immediate-release film-coated tablets, debossed with “Pfizer” on one side, and “JKI 5” on the other side.
- 10 mg tofacitinib: Blue, round, immediate-release film-coated tablets, debossed with “Pfizer” on one side, and “JKI 10” on the other side.

XELJANZ XR Tablets:

- 11 mg tofacitinib: Pink, oval, extended-release film-coated tablets with a drilled hole at one end of the tablet band and “JKI 11” printed on one side of the tablet.
- 22 mg tofacitinib: Beige, oval, extended-release film-coated tablets with a drilled hole at one end of the tablet band and “JKI 22” printed on one side of the tablet.

4 CONTRAINDICATIONS

None.

5 WARNINGS AND PRECAUTIONS

5.1 Serious Infections

Serious and sometimes fatal infections due to bacterial, mycobacterial, invasive fungal, viral, or other opportunistic pathogens have been reported in patients receiving XELJANZ. The most common serious infections reported with XELJANZ included pneumonia, cellulitis, herpes zoster, urinary tract infection, diverticulitis, and appendicitis. Among opportunistic infections, tuberculosis and other mycobacterial infections, cryptococcosis, histoplasmosis, esophageal candidiasis, pneumocystosis, multidermatomal herpes zoster, cytomegalovirus infections, BK virus infection, and listeriosis were reported with XELJANZ. Some patients have presented with disseminated rather than localized disease, and were often taking concomitant immunomodulating agents such as methotrexate or corticosteroids.

In the UC population, XELJANZ treatment with 10 mg twice daily was associated with greater risk of serious infections compared to 5 mg twice daily. Additionally, opportunistic herpes zoster infections (including meningoencephalitis, ophthalmologic, and disseminated cutaneous) were seen in patients who were treated with XELJANZ 10 mg twice daily.

Other serious infections that were not reported in clinical studies may also occur (e.g., coccidioidomycosis).

Avoid use of XELJANZ/XELJANZ XR in patients with an active, serious infection, including localized infections. The risks and benefits of treatment should be considered prior to initiating XELJANZ/XELJANZ XR in patients:

- with chronic or recurrent infection
- who have been exposed to tuberculosis
- with a history of a serious or an opportunistic infection
- who have resided or traveled in areas of endemic tuberculosis or endemic mycoses; or
- with underlying conditions that may predispose them to infection.

Patients should be closely monitored for the development of signs and symptoms of infection during and after treatment with XELJANZ/XELJANZ XR. XELJANZ/XELJANZ XR should be interrupted if a patient develops a serious infection, an opportunistic infection, or sepsis. A patient who develops a new infection during treatment with XELJANZ/XELJANZ XR should undergo prompt and complete diagnostic testing appropriate for an immunocompromised patient; appropriate antimicrobial therapy should be initiated, and the patient should be closely monitored.

Caution is also recommended in patients with a history of chronic lung disease, or in those who develop interstitial lung disease, as they may be more prone to infections.

Risk of infection may be higher with increasing degrees of lymphopenia and consideration should be given to lymphocyte counts when assessing individual patient risk of infection. Discontinuation and monitoring criteria for lymphopenia are recommended [*see Dosage and Administration (2.2, 2.3)*].

Tuberculosis

Patients should be evaluated and tested for latent or active infection prior to and per applicable guidelines during administration of XELJANZ/XELJANZ XR.

Anti-tuberculosis therapy should also be considered prior to administration of XELJANZ/XELJANZ XR in patients with a past history of latent or active tuberculosis in whom an adequate course of treatment cannot be confirmed, and for patients with a negative test for latent tuberculosis but who have risk factors for tuberculosis infection. Consultation with a physician with expertise in the treatment of tuberculosis is recommended to aid in the decision about whether initiating anti-tuberculosis therapy is appropriate for an individual patient.

Patients should be closely monitored for the development of signs and symptoms of tuberculosis, including patients who tested negative for latent tuberculosis infection prior to initiating therapy.

Patients with latent tuberculosis should be treated with standard antimycobacterial therapy before administering XELJANZ/XELJANZ XR.

Viral Reactivation

Viral reactivation, including cases of herpes virus reactivation (e.g., herpes zoster), were observed in clinical studies with XELJANZ. Postmarketing cases of hepatitis B reactivation have been reported in patients treated with XELJANZ. The impact of XELJANZ/XELJANZ XR on chronic viral hepatitis reactivation is unknown. Patients who screened positive for hepatitis B or C were excluded from clinical trials. Screening for viral hepatitis should be performed in accordance with clinical guidelines before starting therapy with XELJANZ/XELJANZ XR. The risk of herpes zoster is increased in patients treated with XELJANZ/XELJANZ XR and appears to be higher in patients treated with XELJANZ in Japan and Korea.

5.2 Mortality

Rheumatoid arthritis patients 50 years of age and older with at least one cardiovascular (CV) risk factor treated with XELJANZ 10 mg twice a day had a higher rate of all-cause mortality, including sudden CV death, compared to those treated with XELJANZ 5 mg given twice daily or TNF blockers in a large, ongoing, postmarketing safety study.

A dosage of XELJANZ 10 mg twice daily or XELJANZ XR 22 mg once daily is not recommended for the treatment of RA or PsA [*see Dosage and Administration (2.2)*].

For the treatment of UC, use XELJANZ at the lowest effective dose and for the shortest duration needed to achieve/maintain therapeutic response [*see Dosage and Administration (2.3)*].

5.3 Malignancy and Lymphoproliferative Disorders

Consider the risks and benefits of XELJANZ/XELJANZ XR treatment prior to initiating therapy in patients with a known malignancy other than a successfully treated non-melanoma skin cancer (NMSC) or when considering continuing XELJANZ/XELJANZ XR in patients who develop a malignancy. Malignancies were observed in clinical studies of XELJANZ [*see Adverse Reactions (6.1)*].

In the seven controlled rheumatoid arthritis clinical studies, 11 solid cancers and one lymphoma were diagnosed in 3328 patients receiving XELJANZ with or without DMARD, compared to 0 solid cancers and 0 lymphomas in 809 patients in the placebo with or without DMARD group during the first 12 months of exposure. Lymphomas and solid cancers have also been observed in the long-term extension studies in rheumatoid arthritis patients treated with XELJANZ.

During the 2 PsA controlled clinical studies there were 3 malignancies (excluding NMSC) in 474 patients receiving XELJANZ plus nonbiologic DMARD (6 to 12 months exposure) compared with 0 malignancies in 236 patients in the placebo plus nonbiologic DMARD group (3 months exposure) and 0 malignancies in 106 patients in the adalimumab plus nonbiologic DMARD group (12 months exposure). No lymphomas were reported. Malignancies have also been observed in the long-term extension study in psoriatic arthritis patients treated with XELJANZ.

During the UC controlled clinical studies (8-week induction and 52-week maintenance studies), which included 1220 patients, 0 cases of solid cancer or lymphoma were observed in XELJANZ-treated patients. In the long-term extension study, malignancies (including solid cancers and lymphomas) were observed more often in patients treated with XELJANZ 10 mg twice daily.

In Phase 2B, controlled dose-ranging trials in *de-novo* renal transplant patients, all of whom received induction therapy with basiliximab, high-dose corticosteroids, and mycophenolic acid products, Epstein Barr Virus-associated post-transplant lymphoproliferative disorder was observed in 5 out of 218 patients treated with XELJANZ (2.3%) compared to 0 out of 111 patients treated with cyclosporine.

Other malignancies were observed in clinical studies and the postmarketing setting, including, but not limited to, lung cancer, breast cancer, melanoma, prostate cancer, and pancreatic cancer.

Non-Melanoma Skin Cancer

Non-melanoma skin cancers (NMSCs) have been reported in patients treated with XELJANZ. Periodic skin examination is recommended for patients who are at increased risk for skin cancer. In the UC population, treatment with XELJANZ 10 mg twice daily was associated with greater risk of NMSC.

5.4 Thrombosis

Thrombosis, including pulmonary embolism, deep venous thrombosis, and arterial thrombosis, have occurred in patients treated with XELJANZ and other Janus kinase (JAK) inhibitors used to treat inflammatory conditions. Patients with rheumatoid arthritis 50 years of age and older with at least one CV risk factor treated with XELJANZ 10 mg twice daily compared to XELJANZ 5 mg twice daily or TNF blockers in a large, ongoing postmarketing study had an observed increase in incidence of these events. Many of these events were serious and some resulted in death [see *Warnings and Precautions* (5.2)].

A dosage of XELJANZ 10 mg twice daily or XELJANZ XR 22 mg once daily is not recommended for the treatment of RA or PsA [see *Dosage and Administration* (2.2)].

In a long-term extension study in patients with UC, four cases of pulmonary embolism were reported in patients taking XELJANZ 10 mg twice daily, including one death in a patient with advanced cancer.

Promptly evaluate patients with symptoms of thrombosis and discontinue XELJANZ/XELJANZ XR in patients with symptoms of thrombosis.

Avoid XELJANZ/XELJANZ XR in patients that may be at increased risk of thrombosis. For the treatment of UC, use XELJANZ at the lowest effective dose and for the shortest duration needed to achieve/maintain therapeutic response [*see Dosage and Administration (2.3)*].

5.5 Gastrointestinal Perforations

Events of gastrointestinal perforation have been reported in clinical studies with XELJANZ, although the role of JAK inhibition in these events is not known. In these studies, many patients with rheumatoid arthritis were receiving background therapy with Nonsteroidal Anti-Inflammatory Drugs (NSAIDs).

There was no discernable difference in frequency of gastrointestinal perforation between the placebo and the XELJANZ arms in clinical trials of patients with UC, and many of them were receiving background corticosteroids.

XELJANZ/XELJANZ XR should be used with caution in patients who may be at increased risk for gastrointestinal perforation (e.g., patients with a history of diverticulitis or taking NSAIDs). Patients presenting with new onset abdominal symptoms should be evaluated promptly for early identification of gastrointestinal perforation [*see Adverse Reactions (6.1)*].

5.6 Hypersensitivity

Reactions such as angioedema and urticaria that may reflect drug hypersensitivity have been observed in patients receiving XELJANZ/XELJANZ XR. Some events were serious. If a serious hypersensitivity reaction occurs, promptly discontinue tofacitinib while evaluating the potential cause or causes of the reaction [*see Adverse Reactions (6.2)*].

5.7 Laboratory Abnormalities

Lymphocyte Abnormalities

Treatment with XELJANZ was associated with initial lymphocytosis at one month of exposure followed by a gradual decrease in mean absolute lymphocyte counts below the baseline of approximately 10% during 12 months of therapy. Lymphocyte counts less than 500 cells/mm³ were associated with an increased incidence of treated and serious infections.

Avoid initiation of XELJANZ/XELJANZ XR treatment in patients with a low lymphocyte count (i.e., less than 500 cells/mm³). In patients who develop a confirmed absolute lymphocyte count less than 500 cells/mm³, treatment with XELJANZ/XELJANZ XR is not recommended.

Monitor lymphocyte counts at baseline and every 3 months thereafter. For recommended modifications based on lymphocyte counts [see *Dosage and Administration (2.2, 2.3)*].

Neutropenia

Treatment with XELJANZ was associated with an increased incidence of neutropenia (less than 2000 cells/mm³) compared to placebo.

Avoid initiation of XELJANZ/XELJANZ XR treatment in patients with a low neutrophil count (i.e., ANC less than 1000 cells/mm³). For patients who develop a persistent ANC of 500 to 1000 cells/mm³, interrupt XELJANZ/XELJANZ XR dosing until ANC is greater than or equal to 1000 cells/mm³. In patients who develop an ANC less than 500 cells/mm³, treatment with XELJANZ/XELJANZ XR is not recommended.

Monitor neutrophil counts at baseline and after 4-8 weeks of treatment and every 3 months thereafter. For recommended modifications based on ANC results [see *Dosage and Administration (2.2, 2.3)*].

Anemia

Avoid initiation of XELJANZ/XELJANZ XR treatment in patients with a low hemoglobin level (i.e., less than 9 g/dL). Treatment with XELJANZ/XELJANZ XR should be interrupted in patients who develop hemoglobin levels less than 8 g/dL or whose hemoglobin level drops greater than 2 g/dL on treatment.

Monitor hemoglobin at baseline and after 4-8 weeks of treatment and every 3 months thereafter. For recommended modifications based on hemoglobin results [see *Dosage and Administration (2)*].

Liver Enzyme Elevations

Treatment with XELJANZ was associated with an increased incidence of liver enzyme elevation compared to placebo. Most of these abnormalities occurred in studies with background DMARD (primarily methotrexate) therapy.

Routine monitoring of liver tests and prompt investigation of the causes of liver enzyme elevations is recommended to identify potential cases of drug-induced liver injury. If drug-induced liver injury is suspected, the administration of XELJANZ/XELJANZ XR should be interrupted until this diagnosis has been excluded.

Lipid Elevations

Treatment with XELJANZ was associated with dose-dependent increases in lipid parameters including total cholesterol, low-density lipoprotein (LDL) cholesterol, and high-density lipoprotein (HDL) cholesterol. Maximum effects were generally observed within 6 weeks. There were no clinically relevant changes in LDL/HDL cholesterol ratios. The effect of these lipid parameter elevations on cardiovascular morbidity and mortality has not been determined.

Assessment of lipid parameters should be performed approximately 4-8 weeks following initiation of XELJANZ/XELJANZ XR therapy.

Manage patients according to clinical guidelines [e.g., National Cholesterol Educational Program (NCEP)] for the management of hyperlipidemia.

5.8 Vaccinations

Avoid use of live vaccines concurrently with XELJANZ/XELJANZ XR. The interval between live vaccinations and initiation of tofacitinib therapy should be in accordance with current vaccination guidelines regarding immunosuppressive agents.

A patient experienced dissemination of the vaccine strain of varicella zoster virus, 16 days after vaccination with live attenuated (Zostavax) virus vaccine and 2 days after treatment start with tofacitinib 5 mg twice daily. The patient was varicella virus naïve, as evidenced by no previous history of varicella infection and no anti-varicella antibodies at baseline. Tofacitinib was discontinued and the patient recovered after treatment with standard doses of antiviral medication.

Update immunizations in agreement with current immunization guidelines prior to initiating XELJANZ/XELJANZ XR therapy.

5.9 Risk of Gastrointestinal Obstruction with a Non-Deformable Extended-Release Formulation such as XELJANZ XR

As with any other non-deformable material, caution should be used when administering XELJANZ XR to patients with pre-existing severe gastrointestinal narrowing (pathologic or iatrogenic). There have been rare reports of obstructive symptoms in patients with known strictures in association with the ingestion of other drugs utilizing a non-deformable extended-release formulation.

6 ADVERSE REACTIONS

The following clinically significant adverse reactions are described elsewhere in the labeling:

- Serious Infections [*see Warnings and Precautions (5.1)*]
- Mortality [*see Warnings and Precautions (5.2)*]
- Malignancy and Lymphoproliferative Disorders [*see Warnings and Precautions (5.3)*]
- Thrombosis [*see Warnings and Precautions (5.4)*]
- Gastrointestinal Perforations [*see Warnings and Precautions (5.5)*]
- Hypersensitivity [*see Warnings and Precautions (5.6)*]
- Laboratory Abnormalities [*see Warnings and Precautions (5.7)*]

6.1 Clinical Trials Experience

Because clinical studies are conducted under widely varying conditions, adverse reaction rates observed in the clinical studies of a drug cannot be directly compared to rates in the clinical studies of another drug and may not predict the rates observed in a broader patient population in clinical practice.

Rheumatoid Arthritis

The clinical studies described in the following sections were conducted using XELJANZ. Although other doses of XELJANZ have been studied, the recommended dose of XELJANZ is 5 mg twice daily. The recommended dose for XELJANZ XR is 11 mg once daily. A dosage of XELJANZ 10 mg twice daily or XELJANZ XR 22 mg once daily is not a recommended regimen for the treatment of rheumatoid arthritis [*see Dosage and Administration (2.2)*].

The following data includes two Phase 2 and five Phase 3 double-blind, controlled, multicenter trials. In these trials, patients were randomized to doses of XELJANZ 5 mg twice daily (292 patients) and 10 mg twice daily (306 patients) monotherapy, XELJANZ 5 mg twice daily (1044 patients) and 10 mg twice daily (1043 patients) in combination with DMARDs (including methotrexate) and placebo (809 patients). All seven protocols included provisions for patients taking placebo to receive treatment with XELJANZ at Month 3 or Month 6 either by patient response (based on uncontrolled disease activity) or by design, so that adverse events cannot always be unambiguously attributed to a given treatment. Therefore, some analyses that follow include patients who changed treatment by design or by patient response from placebo to XELJANZ in both the placebo and XELJANZ group of a given interval. Comparisons between placebo and XELJANZ were based on the first 3 months of exposure, and comparisons between XELJANZ 5 mg twice daily and XELJANZ 10 mg twice daily were based on the first 12 months of exposure.

The long-term safety population includes all patients who participated in a double-blind, controlled trial (including earlier development phase studies) and then participated in one of two long-term safety studies. The design of the long-term safety studies allowed for modification of XELJANZ doses according to clinical judgment. This limits the interpretation of the long-term safety data with respect to dose.

The most common serious adverse reactions were serious infections [*see Warnings and Precautions (5.1)*].

The proportion of patients who discontinued treatment due to any adverse reaction during the 0 to 3 months exposure in the double-blind, placebo-controlled trials was 4% for patients taking XELJANZ and 3% for placebo-treated patients.

Overall Infections

In the seven controlled trials, during the 0 to 3 months exposure, the overall frequency of infections was 20% and 22% in the 5 mg twice daily and 10 mg twice daily groups, respectively, and 18% in the placebo group.

The most commonly reported infections with XELJANZ were upper respiratory tract infections, nasopharyngitis, and urinary tract infections (4%, 3%, and 2% of patients, respectively).

Serious Infections

In the seven controlled trials, during the 0 to 3 months exposure, serious infections were reported in 1 patient (0.5 events per 100 patient-years) who received placebo and 11 patients (1.7 events per 100 patient-years) who received XELJANZ 5 mg or 10 mg twice daily. The rate difference

between treatment groups (and the corresponding 95% confidence interval) was 1.1 (-0.4, 2.5) events per 100 patient-years for the combined 5 mg twice daily and 10 mg twice daily XELJANZ group minus placebo.

In the seven controlled trials, during the 0 to 12 months exposure, serious infections were reported in 34 patients (2.7 events per 100 patient-years) who received 5 mg twice daily of XELJANZ and 33 patients (2.7 events per 100 patient-years) who received 10 mg twice daily of XELJANZ. The rate difference between XELJANZ doses (and the corresponding 95% confidence interval) was -0.1 (-1.3, 1.2) events per 100 patient-years for 10 mg twice daily XELJANZ minus 5 mg twice daily XELJANZ.

The most common serious infections included pneumonia, cellulitis, herpes zoster, and urinary tract infection [*see Warnings and Precautions (5.1)*].

Tuberculosis

In the seven controlled trials, during the 0 to 3 months exposure, tuberculosis was not reported in patients who received placebo, 5 mg twice daily of XELJANZ, or 10 mg twice daily of XELJANZ.

In the seven controlled trials, during the 0 to 12 months exposure, tuberculosis was reported in 0 patients who received 5 mg twice daily of XELJANZ and 6 patients (0.5 events per 100 patient-years) who received 10 mg twice daily of XELJANZ. The rate difference between XELJANZ doses (and the corresponding 95% confidence interval) was 0.5 (0.1, 0.9) events per 100 patient-years for 10 mg twice daily XELJANZ minus 5 mg twice daily XELJANZ.

Cases of disseminated tuberculosis were also reported. The median XELJANZ exposure prior to diagnosis of tuberculosis was 10 months (range from 152 to 960 days) [*see Warnings and Precautions (5.1)*].

Opportunistic Infections (excluding tuberculosis)

In the seven controlled trials, during the 0 to 3 months exposure, opportunistic infections were not reported in patients who received placebo, 5 mg twice daily of XELJANZ, or 10 mg twice daily of XELJANZ.

In the seven controlled trials, during the 0 to 12 months exposure, opportunistic infections were reported in 4 patients (0.3 events per 100 patient-years) who received 5 mg twice daily of XELJANZ and 4 patients (0.3 events per 100 patient-years) who received 10 mg twice daily of XELJANZ. The rate difference between XELJANZ doses (and the corresponding 95% confidence interval) was 0 (-0.5, 0.5) events per 100 patient-years for 10 mg twice daily XELJANZ minus 5 mg twice daily XELJANZ.

The median XELJANZ exposure prior to diagnosis of an opportunistic infection was 8 months (range from 41 to 698 days) [*see Warnings and Precautions (5.1)*].

Malignancy

In the seven controlled trials, during the 0 to 3 months exposure, malignancies excluding NMSC were reported in 0 patients who received placebo and 2 patients (0.3 events per 100 patient-years) who received either XELJANZ 5 mg or 10 mg twice daily. The rate difference between treatment groups (and the corresponding 95% confidence interval) was 0.3 (-0.1, 0.7) events per 100 patient-years for the combined 5 mg and 10 mg twice daily XELJANZ group minus placebo.

In the seven controlled trials, during the 0 to 12 months exposure, malignancies excluding NMSC were reported in 5 patients (0.4 events per 100 patient-years) who received 5 mg twice daily of XELJANZ and 7 patients (0.6 events per 100 patient-years) who received 10 mg twice daily of XELJANZ. The rate difference between XELJANZ doses (and the corresponding 95% confidence interval) was 0.2 (-0.4, 0.7) events per 100 patient-years for 10 mg twice daily XELJANZ minus 5 mg twice daily XELJANZ. One of these malignancies was a case of lymphoma that occurred during the 0 to 12 month period in a patient treated with XELJANZ 10 mg twice daily.

The most common types of malignancy, including malignancies observed during the long-term extension, were lung and breast cancer, followed by gastric, colorectal, renal cell, prostate cancer, lymphoma, and malignant melanoma [*see Warnings and Precautions (5.3)*].

Laboratory Abnormalities

Lymphopenia

In the controlled clinical trials, confirmed decreases in absolute lymphocyte counts below 500 cells/mm³ occurred in 0.04% of patients for the 5 mg twice daily and 10 mg twice daily XELJANZ groups combined during the first 3 months of exposure.

Confirmed lymphocyte counts less than 500 cells/mm³ were associated with an increased incidence of treated and serious infections [*see Warnings and Precautions (5.7)*].

Neutropenia

In the controlled clinical trials, confirmed decreases in ANC below 1000 cells/mm³ occurred in 0.07% of patients for the 5 mg twice daily and 10 mg twice daily XELJANZ groups combined during the first 3 months of exposure.

There were no confirmed decreases in ANC below 500 cells/mm³ observed in any treatment group.

There was no clear relationship between neutropenia and the occurrence of serious infections.

In the long-term safety population, the pattern and incidence of confirmed decreases in ANC remained consistent with what was seen in the controlled clinical trials [*see Warnings and Precautions (5.7)*].

Liver Enzyme Elevations

Confirmed increases in liver enzymes greater than 3 times the upper limit of normal (3x ULN) were observed in patients treated with XELJANZ. In patients experiencing liver enzyme elevation, modification of treatment regimen, such as reduction in the dose of concomitant DMARD, interruption of XELJANZ, or reduction in XELJANZ dose, resulted in decrease or normalization of liver enzymes.

In the controlled monotherapy trials (0-3 months), no differences in the incidence of ALT or AST elevations were observed between the placebo, and XELJANZ 5 mg, and 10 mg twice daily groups.

In the controlled background DMARD trials (0-3 months), ALT elevations greater than 3x ULN were observed in 1.0%, 1.3% and 1.2% of patients receiving placebo, 5 mg, and 10 mg twice daily, respectively. In these trials, AST elevations greater than 3x ULN were observed in 0.6%, 0.5% and 0.4% of patients receiving placebo, 5 mg, and 10 mg twice daily, respectively.

One case of drug-induced liver injury was reported in a patient treated with XELJANZ 10 mg twice daily for approximately 2.5 months. The patient developed symptomatic elevations of AST and ALT greater than 3x ULN and bilirubin elevations greater than 2x ULN, which required hospitalizations and a liver biopsy.

Lipid Elevations

In the controlled clinical trials, dose-related elevations in lipid parameters (total cholesterol, LDL cholesterol, HDL cholesterol, triglycerides) were observed at one month of exposure and remained stable thereafter. Changes in lipid parameters during the first 3 months of exposure in the controlled clinical trials are summarized below:

- Mean LDL cholesterol increased by 15% in the XELJANZ 5 mg twice daily arm and 19% in the XELJANZ 10 mg twice daily arm.
- Mean HDL cholesterol increased by 10% in the XELJANZ 5 mg twice daily arm and 12% in the XELJANZ 10 mg twice daily arm.
- Mean LDL/HDL ratios were essentially unchanged in XELJANZ-treated patients.

In a controlled clinical trial, elevations in LDL cholesterol and ApoB decreased to pretreatment levels in response to statin therapy.

In the long-term safety population, elevations in lipid parameters remained consistent with what was seen in the controlled clinical trials.

Serum Creatinine Elevations

In the controlled clinical trials, dose-related elevations in serum creatinine were observed with XELJANZ treatment. The mean increase in serum creatinine was <0.1 mg/dL in the 12-month pooled safety analysis; however with increasing duration of exposure in the long-term extensions, up to 2% of patients were discontinued from XELJANZ treatment due to the protocol-specified discontinuation criterion of an increase in creatinine by more than 50% of baseline. The clinical significance of the observed serum creatinine elevations is unknown.

Other Adverse Reactions

Adverse reactions occurring in 2% or more of patients on 5 mg twice daily or 10 mg twice daily XELJANZ and at least 1% greater than that observed in patients on placebo with or without DMARD are summarized in Table 3.

Table 3: Common Adverse Reactions* in Clinical Trials of XELJANZ for the Treatment of Rheumatoid Arthritis With or Without Concomitant DMARDs (0-3 Months)

Preferred Term	XELJANZ 5 mg Twice Daily	XELJANZ 10 mg Twice Daily**	Placebo
	N = 1336 (%)	N = 1349 (%)	N = 809 (%)
Upper respiratory tract infection	4	4	3
Nasopharyngitis	4	3	3
Diarrhea	4	3	2
Headache	4	3	2
Hypertension	2	2	1

N reflects randomized and treated patients from the seven clinical trials.

* reported in $\geq 2\%$ of patients treated with either dose of XELJANZ and $\geq 1\%$ greater than that reported for placebo.

** the recommended dose of XELJANZ for the treatment of rheumatoid arthritis is 5 mg twice daily [see Dosage and Administration (2)].

Other adverse reactions occurring in controlled and open-label extension studies included:

Blood and lymphatic system disorders: Anemia

Infections and infestations: Diverticulitis

Metabolism and nutrition disorders: Dehydration

Psychiatric disorders: Insomnia

Nervous system disorders: Paresthesia

Respiratory, thoracic and mediastinal disorders: Dyspnea, cough, sinus congestion, interstitial lung disease (cases were limited to patients with rheumatoid arthritis and some were fatal)

Gastrointestinal disorders: Abdominal pain, dyspepsia, vomiting, gastritis, nausea

Hepatobiliary disorders: Hepatic steatosis

Skin and subcutaneous tissue disorders: Rash, erythema, pruritus

Musculoskeletal, connective tissue and bone disorders: Musculoskeletal pain, arthralgia, tendonitis, joint swelling

Neoplasms benign, malignant and unspecified (including cysts and polyps): Non-melanoma skin cancers

General disorders and administration site conditions: Pyrexia, fatigue, peripheral edema

Clinical Experience in Methotrexate-Naïve Patients

Study RA-VI was an active-controlled clinical trial in methotrexate-naïve patients [see Clinical Studies (14)]. The safety experience in these patients was consistent with Studies RA-I through V.

Psoriatic Arthritis

XELJANZ 5 mg twice daily and 10 mg twice daily were studied in 2 double-blind Phase 3 clinical trials in patients with active psoriatic arthritis (PsA). Although other doses of XELJANZ have been studied, the recommended dose of XELJANZ is 5 mg twice daily. The recommended dose for XELJANZ XR is 11 mg once daily. A dosage of XELJANZ 10 mg twice daily or XELJANZ XR 22 mg once daily is not recommended for the treatment of PsA [see *Dosage and Administration (2.2)*].

Study PsA-I (NCT01877668) had a duration of 12 months and enrolled patients who had an inadequate response to a nonbiologic DMARD and who were naïve to treatment with a TNF blocker. Study PsA-I included a 3-month placebo-controlled period and also included adalimumab 40 mg subcutaneously once every 2 weeks for 12 months.

Study PsA-II (NCT01882439) had a duration of 6 months and enrolled patients who had an inadequate response to at least one approved TNF blocker. This clinical trial included a 3-month placebo controlled period.

In these combined Phase 3 clinical trials, 238 patients were randomized and treated with XELJANZ 5 mg twice daily and 236 patients were randomized and treated with XELJANZ 10 mg twice daily. All patients in the clinical trials were required to receive treatment with a stable dose of a nonbiologic DMARD [the majority (79%) received methotrexate]. The study population randomized and treated with XELJANZ (474 patients) included 45 (9.5%) patients aged 65 years or older and 66 (13.9%) patients with diabetes at baseline.

The safety profile observed in patients with active psoriatic arthritis treated with XELJANZ was consistent with the safety profile observed in rheumatoid arthritis patients.

Ulcerative Colitis

XELJANZ has been studied in patients with moderately to severely active UC in 4 randomized, double-blind, placebo-controlled trials (UC-I, UC-II, UC-III, and dose-ranging UC-V) and an open-label long-term extension study (UC-IV) [see *Clinical Studies (14.3)*].

Adverse reactions reported in $\geq 5\%$ of patients treated with either 5 mg or 10 mg twice daily of XELJANZ and $\geq 1\%$ greater than reported in patients receiving placebo in either the induction or maintenance clinical trials were: nasopharyngitis, elevated cholesterol levels, headache, upper respiratory tract infection, increased blood creatine phosphokinase, rash, diarrhea, and herpes zoster.

Induction Trials (Study UC-I, UC-II, and UC-V):

Common adverse reactions reported in $\geq 2\%$ of patients treated with XELJANZ 10 mg twice daily and $\geq 1\%$ greater than that reported in patients receiving placebo in the 3 induction trials were: headache, nasopharyngitis, elevated cholesterol levels, acne, increased blood creatine phosphokinase, and pyrexia.

Maintenance Trial (Study UC-III)

Common adverse reactions reported in $\geq 4\%$ of patients treated with either dose of XELJANZ and $\geq 1\%$ greater than reported in patients receiving placebo are shown in Table 4.

Table 4: Common Adverse Reactions* in -UC Patients during the Maintenance Trial (Study UC-III)

Preferred Term	XELJANZ 5 mg Twice Daily	XELJANZ 10 mg Twice Dail y	Placebo
	N = 198 (%)	N = 196 (%)	N = 198 (%)
Nasopharyngitis	10	14	6
Elevated cholesterol levels**	5	9	1
Headache	9	3	6
Upper respiratory tract infection	7	6	4
Increased blood creatine phosphokinase	3	7	2
Rash	3	6	4
Diarrhea	2	5	3
Herpes zoster	1	5	1
Gastroenteritis	3	4	3
Anemia	4	2	2
Nausea	1	4	3

* reported in $\geq 4\%$ of patients treated with either dose of XELJANZ and $\geq 1\%$ greater than reported for placebo.

** includes hypercholesterolemia, hyperlipidemia, blood cholesterol increased, dyslipidemia, blood triglycerides increased, low density lipoprotein increased, low density lipoprotein abnormal, or lipids increased.

In the long-term extension study, malignancies (including solid cancers, lymphomas and NMSC) were observed more often in patients treated with XELJANZ 10 mg twice daily [see *Warnings and Precautions* (5.3)]. Four cases of pulmonary embolism were reported in patients taking XELJANZ 10 mg twice daily, including one fatality in a patient with advanced cancer [see *Warnings and Precautions* (5.4)].

Dose-dependent adverse reactions seen in patients treated with XELJANZ 10 mg twice daily, in comparison to 5 mg twice daily, include the following: herpes zoster infections, serious infections, and NMSC [see *Warnings and Precautions* (5.1, 5.3)].

6.2 Postmarketing Experience

The following adverse reactions have been identified during post-approval use of XELJANZ/XELJANZ XR. Because these reactions are reported voluntarily from a population of uncertain size, it is not always possible to reliably estimate their frequency or establish a causal relationship to drug exposure.

Immune system disorders: Drug hypersensitivity (events such as angioedema and urticaria have been observed).

7 DRUG INTERACTIONS

Table 5 includes drugs with clinically important drug interactions when administered concomitantly with XELJANZ/XELJANZ XR and instructions for preventing or managing them.

Table 5: Clinical Relevant Interactions Affecting XELJANZ and XELJANZ XR When Coadministered with Other Drugs

Strong CP3A4 Inhibitors (e.g., ketoconazole)	
<i>Clinical Impact</i>	Increased exposure to tofacitinib
<i>Intervention</i>	Dosage adjustment of XELJANZ/XELJANZ XR is recommended [see Dosage and Administration (2), Clinical Pharmacology, Figure 3 (12.3)]
Moderate CYP3A4 Inhibitors Coadministered with Strong CYP2C19 Inhibitors (e.g., fluconazole)	
<i>Clinical Impact</i>	Increased exposure to tofacitinib
<i>Intervention</i>	Dosage adjustment of XELJANZ/XELJANZ XR is recommended [see Dosage and Administration (2), Clinical Pharmacology, Figure 3 (12.3)]
Strong CYP3A4 Inducers (e.g., rifampin)	
<i>Clinical Impact</i>	Decreased exposure to tofacitinib and may result in loss of or reduced clinical response
<i>Intervention</i>	Coadministration with XELJANZ/XELJANZ XR is not recommended [see Clinical Pharmacology, Figure 3 (12.3)]
Immunosuppressive Drugs (e.g., azathioprine, tacrolimus, cyclosporine)	
<i>Clinical Impact</i>	Risk of added immunosuppression; coadministration with biologic DMARDs or potent immunosuppressants has not been studied in patients with rheumatoid arthritis, psoriatic arthritis, or UC.
<i>Intervention</i>	Coadministration with XELJANZ/XELJANZ XR is not recommended [see Indications and Usage (1), Clinical Pharmacology, Figure 3 (12.3)]

8 USE IN SPECIFIC POPULATIONS

All information provided in this section is applicable to XELJANZ and XELJANZ XR as they contain the same active ingredient (tofacitinib).

8.1 Pregnancy

Pregnancy Exposure Registry

There is a pregnancy exposure registry that monitors pregnancy outcomes in women exposed to XELJANZ/XELJANZ XR during pregnancy. Patients should be encouraged to enroll in the XELJANZ/XELJANZ XR pregnancy registry if they become pregnant. To enroll or obtain information from the registry, patients can call the toll free number 1-877-311-8972.

Risk Summary

Available data with XELJANZ/XELJANZ XR use in pregnant women are insufficient to establish a drug associated risk of major birth defects, miscarriage or adverse maternal or fetal outcomes. There are risks to the mother and the fetus associated with rheumatoid arthritis and UC in pregnancy (*see Clinical Considerations*). In animal reproduction studies, fetocidal and teratogenic effects were noted when pregnant rats and rabbits received tofacitinib during the period of organogenesis at exposures multiples of 73-times and 6.3-times the maximum recommended dose of 10 mg twice daily, respectively. Further, in a peri- and post-natal study in rats, tofacitinib resulted in reductions in live litter size, postnatal survival, and pup body weights at exposure multiples of approximately 73-times the recommended dose of 5 mg twice daily and approximately 36 times the maximum recommended dose of 10 mg twice daily, respectively (*see Data*).

The estimated background risks of major birth defects and miscarriage for the indicated populations are unknown. All pregnancies have a background risk of birth defect, loss, or other adverse outcomes. The background risks in the U.S. general population of major birth defects and miscarriages are 2 to 4% and 15 to 20% of clinically recognized pregnancies, respectively.

Clinical Considerations

Disease-Associated Maternal and/or Embryo/Fetal Risk

Published data suggest that increased disease activity is associated with the risk of developing adverse pregnancy outcomes in women with rheumatoid arthritis or ulcerative colitis. Adverse pregnancy outcomes include preterm delivery (before 37 weeks of gestation), low birth weight (less than 2500 g) infants, and small for gestational age at birth.

Data

Animal Data

In a rat embryofetal developmental study, in which pregnant rats received tofacitinib during organogenesis, tofacitinib was teratogenic at exposure levels approximately 146 times the recommended dose of 5 mg twice daily, and approximately 73 times the maximum recommended dose of 10 mg twice daily (on an AUC basis at oral doses of 100 mg/kg/day in rats). Teratogenic effects consisted of external and soft tissue malformations of anasarca and membranous ventricular septal defects, respectively; and skeletal malformations or variations (absent cervical arch; bent femur, fibula, humerus, radius, scapula, tibia, and ulna; sternoschisis; absent rib; misshapen femur; branched rib; fused rib; fused sternebra; and hemicentric thoracic centrum). In addition, there was an increase in post-implantation loss, consisting of early and late resorptions, resulting in a reduced number of viable fetuses. Mean fetal body weight was reduced. No developmental toxicity was observed in rats at exposure levels approximately 58 times the recommended dose of 5 mg twice daily, and approximately 29 times the maximum recommended dose of 10 mg twice daily (on an AUC basis at oral doses of 30 mg/kg/day in pregnant rats).

In a rabbit embryofetal developmental study in which pregnant rabbits received tofacitinib during the period of organogenesis, tofacitinib was teratogenic at exposure levels approximately

13 times the recommended dose of 5 mg twice daily, and approximately 6.3 times the maximum recommended dose of 10 mg twice daily (on an AUC basis at oral doses of 30 mg/kg/day in rabbits) in the absence of signs of maternal toxicity. Teratogenic effects included thoracogastroschisis, omphalocele, membranous ventricular septal defects, and cranial/skeletal malformations (microstomia, microphthalmia), mid-line and tail defects. In addition, there was an increase in post-implantation loss associated with late resorptions. No developmental toxicity was observed in rabbits at exposure levels approximately 3 times the recommended dose of 5 mg twice daily, and approximately 1.5 times the maximum recommended dose of 10 mg twice daily (on an AUC basis at oral doses of 10 mg/kg/day in pregnant rabbits).

In a peri- and postnatal development study in pregnant rats that received tofacitinib from gestation day 6 through day 20 of lactation, there were reductions in live litter size, postnatal survival, and pup body weights at exposure levels approximately 73 times the recommended dose of 5 mg twice daily, and approximately 36 times the maximum recommended dose of 10 mg twice daily (on an AUC basis at oral doses of 50 mg/kg/day in rats). There was no effect on behavioral and learning assessments, sexual maturation or the ability of the F1 generation rats to mate and produce viable F2 generation fetuses in rats at exposure levels approximately 17 times the recommended dose of 5 mg twice daily, and approximately 8.3 times the maximum recommended dose of 10 mg twice daily (on an AUC basis at oral doses of 10 mg/kg/day in rats).

8.2 Lactation

Risk Summary

There are no data on the presence of tofacitinib in human milk, the effects on a breastfed infant, or the effects on milk production. Tofacitinib is present in the milk of lactating rats (*see Data*). When a drug is present in animal milk, it is likely that the drug will be present in human milk. Given the serious adverse reactions seen in adults treated with XELJANZ/XELJANZ XR, such as increased risk of serious infections, advise patients that breastfeeding is not recommended during treatment and for at least 18 hours after the last dose of XELJANZ or 36 hours after the last dose of XELJANZ XR (approximately 6 elimination half-lives).

Data

Following administration of tofacitinib to lactating rats, concentrations of tofacitinib in milk over time paralleled those in serum, and were approximately 2 times higher in milk relative to maternal serum at all time points measured.

8.3 Females and Males of Reproductive Potential

Contraception

Females

In an animal reproduction study, tofacitinib at AUC multiples of 13 times the recommended dose of 5 mg twice daily and 6.3 times the maximum recommended dose of 10 mg twice daily demonstrated adverse embryo-fetal findings [*see Use in Specific Populations (8.1)*]. However, there is uncertainty as to how these animal findings relate to females of reproductive potential

treated with the recommended clinical dose. Consider pregnancy planning and prevention for females of reproductive potential.

Infertility

Females

Based on findings in rats, treatment with XELJANZ/XELJANZ XR may result in reduced fertility in females of reproductive potential. It is not known if this effect is reversible [*see Nonclinical Toxicology (13.1)*].

8.4 Pediatric Use

The safety and effectiveness of XELJANZ/XELJANZ XR in pediatric patients have not been established.

8.5 Geriatric Use

Of the 3315 patients who enrolled in rheumatoid arthritis Studies I to V, a total of 505 rheumatoid arthritis patients were 65 years of age and older, including 71 patients 75 years and older. The frequency of serious infection among XELJANZ-treated subjects 65 years of age and older was higher than among those under the age of 65.

Of the 1156 XELJANZ-treated patients in the UC program, a total of 77 patients (7%) were 65 years of age or older. The number of patients aged 65 years and older was not sufficient to determine whether they responded differently from younger patients.

As there is a higher incidence of infections in the elderly population in general, caution should be used when treating the elderly [*see Warnings and Precautions (5.1)*].

8.6 Use in Diabetics

As there is a higher incidence of infection in diabetic population in general, caution should be used when treating patients with diabetes.

8.7 Renal Impairment

Moderate and Severe Impairment

XELJANZ-treated patients with moderate or severe renal impairment had greater tofacitinib blood concentrations than XELJANZ-treated patients with normal renal function. Therefore, dosage adjustment of XELJANZ/XELJANZ XR is recommended in patients with moderate or severe renal impairment (including but not limited to those with severe insufficiency who are undergoing hemodialysis) [*see Dosage and Administration (2.2, 2.3)*].

Mild impairment

No dosage adjustment is required in patients with mild renal impairment.

8.8 Hepatic Impairment

Severe Impairment

XELJANZ/XELJANZ XR has not been studied in patients with severe hepatic impairment; therefore, use of XELJANZ/XELJANZ XR in patients with severe hepatic impairment is not recommended.

Moderate Impairment

XELJANZ-treated patients with moderate hepatic impairment had greater tofacitinib blood concentration than XELJANZ-treated patients with normal hepatic function [*see Clinical Pharmacology (12.3)*]. Higher blood concentrations may increase the risk of some adverse reactions. Therefore, dosage adjustment of XELJANZ/XELJANZ XR is recommended in patients with moderate hepatic impairment [*see Dosage and Administration (2.2, 2.3)*].

Mild Impairment

No dosage adjustment of XELJANZ/XELJANZ XR is required in patients with mild hepatic impairment.

Hepatitis B or C Serology

The safety and efficacy of XELJANZ/XELJANZ XR have not been studied in patients with positive hepatitis B virus or hepatitis C virus serology.

10 OVERDOSAGE

There is no specific antidote for overdose with XELJANZ/XELJANZ XR. In case of an overdose, it is recommended that the patient be monitored for signs and symptoms of adverse reactions.

In a study in subjects with end stage renal disease (ESRD) undergoing hemodialysis, plasma tofacitinib concentrations declined more rapidly during the period of hemodialysis and dialyzer efficiency, calculated as dialyzer clearance/blood flow entering the dialyzer, was high [mean (SD) = 0.73 (0.15)]. However, due to the significant non-renal clearance of tofacitinib, the fraction of total elimination occurring by hemodialysis was small, and thus limits the value of hemodialysis for treatment of overdose with XELJANZ/XELJANZ XR.

11 DESCRIPTION

XELJANZ/XELJANZ XR (tofacitinib) tablets are formulated with the citrate salt of tofacitinib, a JAK inhibitor.

Tofacitinib citrate is a white to off-white powder with the following chemical name: (3R,4R)-4-methyl-3-(methyl-7H-pyrrolo [2,3-d]pyrimidin-4-ylamino)-β-oxo-1-piperidinepropanenitrile, 2-hydroxy-1,2,3-propanetricarboxylate (1:1).

The solubility of tofacitinib citrate in water is 2.9 mg/mL.

Tofacitinib citrate has a molecular weight of 504.5 Daltons (or 312.4 Daltons as the tofacitinib free base) and a molecular formula of $C_{16}H_{20}N_6O \cdot C_6H_8O_7$. The chemical structure of tofacitinib citrate is:

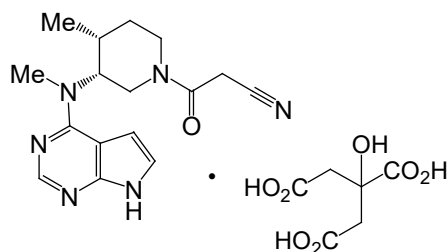

XELJANZ is supplied for oral administration as a 5 mg white round, immediate-release film-coated tablet. Each tablet of XELJANZ contains 5 mg tofacitinib (equivalent to 8.08 mg tofacitinib citrate) and the following inactive ingredients: croscarmellose sodium, HPMC 2910/Hypromellose 6cP, lactose monohydrate, macrogol/PEG3350, magnesium stearate, microcrystalline cellulose, titanium dioxide, and triacetin.

XELJANZ is supplied for oral administration as a 10 mg blue round, immediate-release film-coated tablet. Each 10 mg tablet of XELJANZ contains 10 mg tofacitinib (equivalent to 16.16 mg of tofacitinib citrate) and the following inactive ingredients: croscarmellose sodium, FD&C Blue #1/Brilliant Blue FCF Aluminum Lake, FD&C Blue #2/Indigo Carmine Aluminum Lake, HPMC 2910/Hypromellose 6cP, lactose monohydrate, macrogol/PEG3350, magnesium stearate, microcrystalline cellulose, titanium dioxide, and triacetin.

XELJANZ XR is supplied for oral administration as a 11 mg pink, oval, extended-release film-coated tablet with a drilled hole at one end of the tablet band. Each 11 mg tablet of XELJANZ XR contains 11 mg tofacitinib (equivalent to 17.77 mg tofacitinib citrate) and the following inactive ingredients: cellulose acetate, copovidone, hydroxyethyl cellulose, hydroxypropyl cellulose, HPMC 2910/Hypromellose, magnesium stearate, red iron oxide, sorbitol, titanium dioxide and triacetin. Printing ink contains, ammonium hydroxide, ferrosoferric oxide/black iron oxide, propylene glycol, and shellac glaze.

XELJANZ XR is supplied for oral administration as a 22 mg beige, oval, extended-release film-coated tablet with a drilled hole at one end of the tablet band. Each 22 mg tablet of XELJANZ XR contains 22 mg tofacitinib (equivalent to 35.54 mg tofacitinib citrate) and the following inactive ingredients: cellulose acetate, copovidone, FD&C Blue #2 Aluminum Lake, hydroxyethyl cellulose, hydroxypropyl cellulose, HPMC 2910/Hypromellose, magnesium stearate, red iron oxide, sorbitol, titanium dioxide, triacetin, and yellow iron oxide. Printing ink contains ammonium hydroxide, ferrosoferric oxide/black iron oxide, propylene glycol, and shellac glaze.

12 CLINICAL PHARMACOLOGY

12.1 Mechanism of Action

Tofacitinib is a Janus kinase (JAK) inhibitor. JAKs are intracellular enzymes which transmit signals arising from cytokine or growth factor-receptor interactions on the cellular membrane to influence cellular processes of hematopoiesis and immune cell function. Within the signaling pathway, JAKs phosphorylate and activate Signal Transducers and Activators of Transcription (STATs) which modulate intracellular activity including gene expression. Tofacitinib modulates the signaling pathway at the point of JAKs, preventing the phosphorylation and activation of STATs. JAK enzymes transmit cytokine signaling through pairing of JAKs (e.g., JAK1/JAK3, JAK1/JAK2, JAK1/TyK2, JAK2/JAK2). Tofacitinib inhibited the *in vitro* activities of JAK1/JAK2, JAK1/JAK3, and JAK2/JAK2 combinations with IC₅₀ of 406, 56, and 1377 nM, respectively. However, the relevance of specific JAK combinations to therapeutic effectiveness is not known.

12.2 Pharmacodynamics

Treatment with XELJANZ was associated with dose-dependent reductions of circulating CD16/56+ natural killer cells, with estimated maximum reductions occurring at approximately 8-10 weeks after initiation of therapy. These changes generally resolved within 2-6 weeks after discontinuation of treatment. Treatment with XELJANZ was associated with dose-dependent increases in B cell counts. Changes in circulating T-lymphocyte counts and T-lymphocyte subsets (CD3+, CD4+ and CD8+) were small and inconsistent. The clinical significance of these changes is unknown.

Total serum IgG, IgM, and IgA levels after 6-month dosing in patients with rheumatoid arthritis were lower than placebo; however, changes were small and not dose-dependent.

After treatment with XELJANZ in patients with rheumatoid arthritis, rapid decreases in serum C-reactive protein (CRP) were observed and maintained throughout dosing. Changes in CRP observed with XELJANZ treatment do not reverse fully within 2 weeks after discontinuation, indicating a longer duration of pharmacodynamic activity compared to the pharmacokinetic half-life.

Similar changes in T cells, B cells, and serum CRP have been observed in patients with active psoriatic arthritis although reversibility was not assessed. Total serum immunoglobulins were not assessed in patients with active psoriatic arthritis.

12.3 Pharmacokinetics

XELJANZ

Following oral administration of XELJANZ, peak plasma concentrations are reached within 0.5-1 hour, elimination half-life is about 3 hours and a dose-proportional increase in systemic exposure was observed in the therapeutic dose range. Steady state concentrations are achieved in 24-48 hours with negligible accumulation after twice daily administration.

XELJANZ XR

Following oral administration of XELJANZ XR, peak plasma concentrations are reached at 4 hours and half-life is about 6 to 8 hours. Steady state concentrations are achieved within 48 hours with negligible accumulation after once daily administration.

Table 6: Pharmacokinetic Parameters of XELJANZ/ XELJANZ XR Following Multiple Oral Dosing

PK Parameters ^a (CV%)	XELJANZ		XELJANZ XR	
	5 mg Twice Daily	10 mg Twice Daily	11 mg Once Daily	22 mg Once Daily
AUC ₂₄ (ng.hr/mL)	263.4 (15)	539.6 (22)	269.0 (18)	596.6 (19)
C _{max} (ng/mL)	42.7 (26)	84.7 (18)	38.2 (15)	83.8 (25)
C _{min} (ng/mL)	1.41 (40)	3.10 (54)	1.07 (69)	3.11 (43)
T _{max} (hours)	1.0 (0.5 to 14.0 ^b)	0.8 (0.5 to 14.0 ^b)	4.0 (3.0 to 4.0)	4.0 (2.0 to 4.0)

^a Values represent the geometric mean, except T_{max}, for which the median (range) is shown.

Abbreviations: AUC₂₄ = area under the concentration-time profile from time 0 to 24 hours; C_{max} = maximum plasma concentration; C_{min} = minimum plasma concentration; T_{max} = time to C_{max}; CV = Coefficient of variation.

^b Values beyond 12 hours were after the evening dose which was administered 12 hours after the morning dose of twice-daily XELJANZ

Absorption

XELJANZ

The absolute oral bioavailability of XELJANZ is 74%. Coadministration of XELJANZ with a high-fat meal resulted in no changes in AUC while C_{max} was reduced by 32%. In clinical trials, XELJANZ was administered without regard to meals [*see Dosage and Administration (2.1)*].

XELJANZ XR

Coadministration of XELJANZ XR 11 and 22 mg with a high-fat meal resulted in no changes in AUC while C_{max} was increased by 27% and 19% respectively. T_{max} was extended by approximately 1 hour for both XELJANZ XR 11 and 22 mg.

Distribution

After intravenous administration, the volume of distribution is 87 L. The protein binding of tofacitinib is approximately 40%. Tofacitinib binds predominantly to albumin and does not appear to bind to α 1-acid glycoprotein. Tofacitinib distributes equally between red blood cells and plasma.

Metabolism and Excretion

Clearance mechanisms for tofacitinib are approximately 70% hepatic metabolism and 30% renal excretion of the parent drug. The metabolism of tofacitinib is primarily mediated by CYP3A4 with minor contribution from CYP2C19. In a human radiolabeled study, more than 65% of the total circulating radioactivity was accounted for by unchanged tofacitinib, with the remaining 35% attributed to 8 metabolites, each accounting for less than 8% of total radioactivity. The pharmacologic activity of tofacitinib is attributed to the parent molecule.

Pharmacokinetics in Patient Populations

Population pharmacokinetic analyses indicated that pharmacokinetic characteristics were similar between patients with rheumatoid arthritis, psoriatic arthritis, and UC. The coefficient of variation (%) in AUC of tofacitinib were generally similar across different disease patients, ranging from 22% to 34% (Table 7).

Table 7. XELJANZ Exposure in Patient Populations at 5 mg Twice Daily and 10 mg Twice Daily Doses

Pharmacokinetic Parameters^a	XELJANZ 5 mg Twice Daily			XELJANZ 10 mg Twice Daily
	Rheumatoid Arthritis	Psoriatic Arthritis	Ulcerative Colitis	Ulcerative Colitis
Geometric Mean (CV%)				
AUC _{0-24,ss} (ng·h/mL)	504 (22.0%)	419 (34.1%)	423 (22.6%)	807 (24.6%)

Abbreviations: AUC_{0-24,ss}=area under the plasma concentration-time curve over 24 hours at steady state; CV=coefficient of variation.

^a. Pharmacokinetic parameters estimated based on population pharmacokinetic analysis.

Specific Populations

Covariate evaluation as part of population PK analyses in patient populations indicated no clinically relevant change in tofacitinib exposure, after accounting for differences in renal function (i.e., creatinine clearance) between patients, based on age, weight, gender and race (Figure 1). An approximately linear relationship between body weight and volume of distribution was observed, resulting in higher peak (C_{max}) and lower trough (C_{min}) concentrations in lighter patients. However, this difference is not considered to be clinically relevant.

The effect of renal and hepatic impairment and other intrinsic factors on the pharmacokinetics of tofacitinib is shown in Figure 1.

Figure 1: Impact of Intrinsic Factors on Tofacitinib Pharmacokinetics

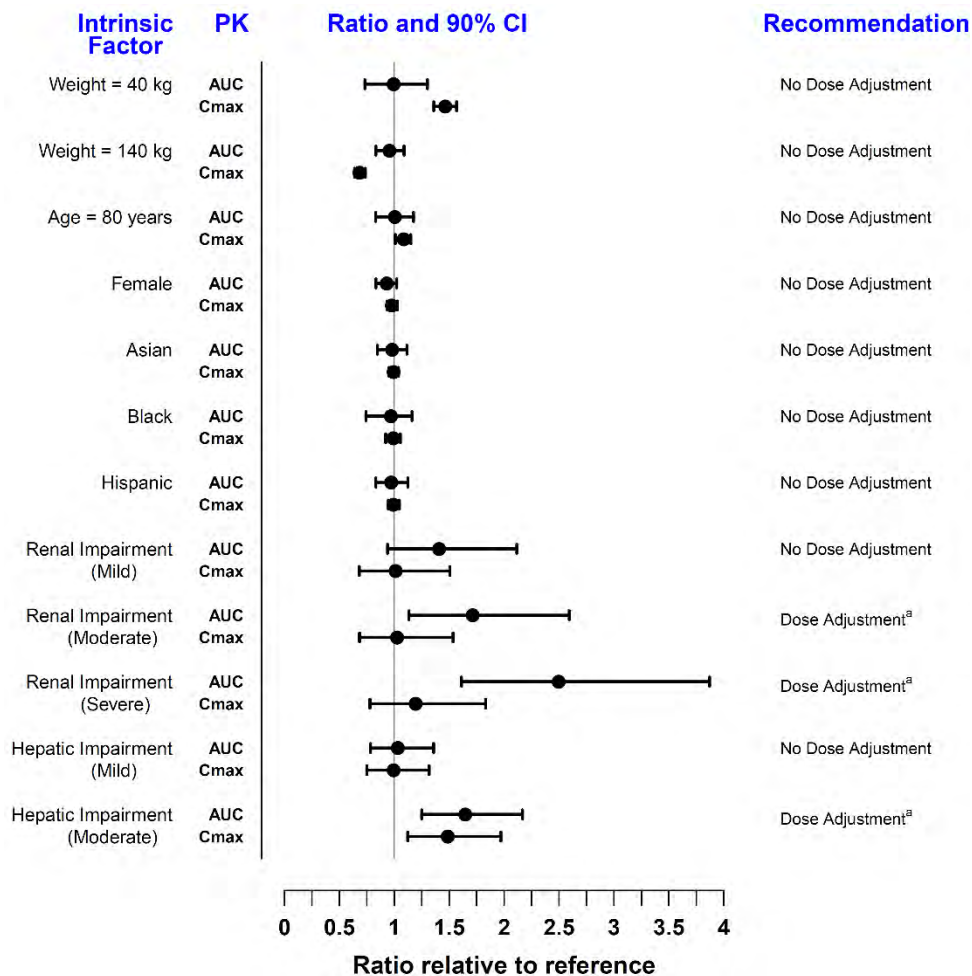

Note: Reference values for weight, age, gender, and race comparisons are 70 kg, 55 years, male, and white, respectively; reference groups for renal and hepatic impairment data are subjects with normal renal and hepatic function.

^a [see Dosage and Administration (2.2, 2.3)] for dosage adjustment in RA, PsA, and UC patients.

In subjects with ESRD maintained on hemodialysis, mean AUC was approximately 40% higher compared with historical healthy subject data, consistent with approximately 30% contribution of renal clearance to the total clearance of tofacitinib. Dose adjustment is recommended in ESRD patients maintained on hemodialysis ([see Dosage and Administration (2.2, 2.3)] for dosage adjustment in RA, PsA, and UC patients).

Drug Interaction Studies

Potential for XELJANZ/XELJANZ XR to Influence the PK of Other Drugs

In vitro studies indicate that tofacitinib does not significantly inhibit or induce the activity of the major human drug-metabolizing CYPs (CYP1A2, CYP2B6, CYP2C8, CYP2C9, CYP2C19, CYP2D6, and CYP3A4) at concentrations corresponding to the steady state C_{max} of a 10 mg twice daily dose. These *in vitro* results were confirmed by a human drug interaction study

showing no changes in the pharmacokinetics of midazolam, a highly sensitive CYP3A4 substrate, when coadministered with XELJANZ.

In vitro studies indicate that tofacitinib does not significantly inhibit the activity of the major human drug-metabolizing uridine 5'-diphospho-glucuronosyltransferases (UGTs) [UGT1A1, UGT1A4, UGT1A6, UGT1A9, and UGT2B7] at concentrations exceeding 250 times the steady state C_{max} of a 10 mg twice daily dose.

In rheumatoid arthritis patients, the oral clearance of tofacitinib does not vary with time, indicating that tofacitinib does not normalize CYP enzyme activity in rheumatoid arthritis patients. Therefore, coadministration with XELJANZ/XELJANZ XR is not expected to result in clinically relevant increases in the metabolism of CYP substrates in rheumatoid arthritis patients.

In vitro data indicate that the potential for tofacitinib to inhibit transporters such as P-glycoprotein, organic anionic or cationic transporters at therapeutic concentrations is low.

Dosing recommendations for coadministered drugs following administration with XELJANZ/XELJANZ XR are shown in Figure 2.

Figure 2: Impact of Tofacitinib on the Pharmacokinetics of Other Drugs

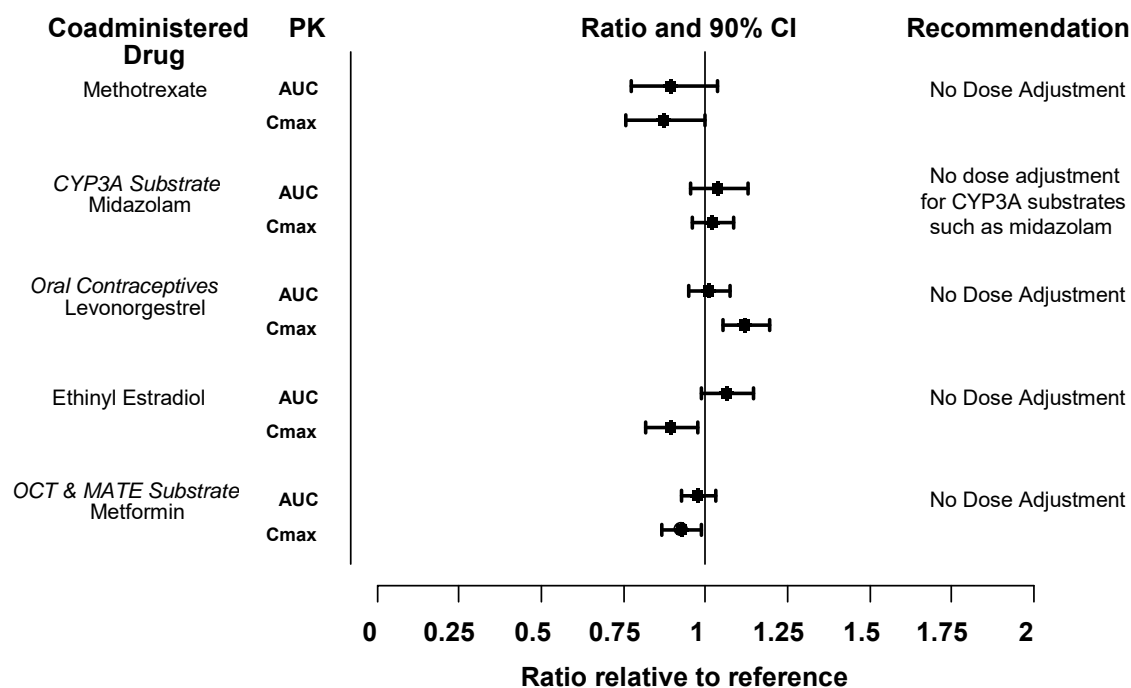

Note: Reference group is administration of concomitant medication alone; OCT = Organic Cationic Transporter; MATE = Multidrug and Toxic Compound Extrusion

Potential for Other Drugs to Influence the Pharmacokinetics of Tofacitinib

Since tofacitinib is metabolized by CYP3A4, interaction with drugs that inhibit or induce CYP3A4 is likely. Inhibitors of CYP2C19 alone or P-glycoprotein are unlikely to substantially alter the pharmacokinetics of tofacitinib (see Figure 3).

Figure 3: Impact of Other Drugs on the Pharmacokinetics of Tofacitinib

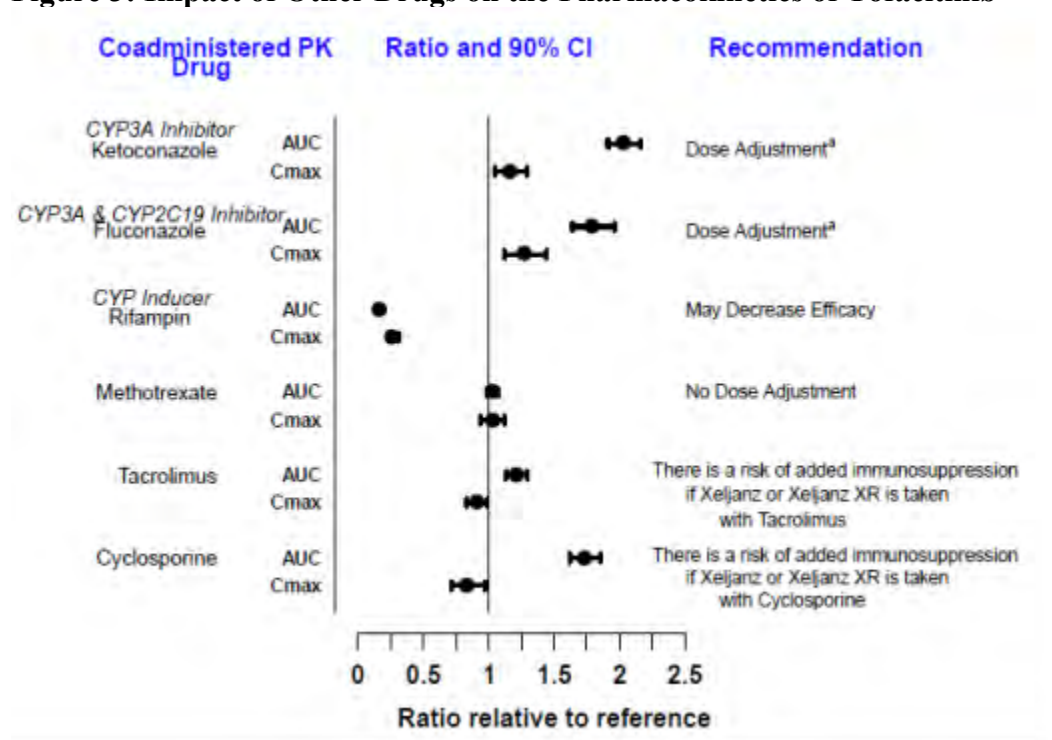

Note: Reference group is administration of tofacitinib alone.

^a [see Dosage and Administration (2.2, 2.3), Drug Interactions (7)].

13 NONCLINICAL TOXICOLOGY

13.1 Carcinogenesis, Mutagenesis, Impairment of Fertility

In a 39-week toxicology study in monkeys, tofacitinib at exposure levels approximately 6 times the recommended dose of 5 mg twice daily, and approximately 3 times the 10 mg twice daily dose (on an AUC basis at oral doses of 5 mg/kg twice daily) produced lymphomas. No lymphomas were observed in this study at exposure levels 1 times the recommended dose of 5 mg twice daily, and approximately 0.5 times the 10 mg twice daily dose (on an AUC basis at oral doses of 1 mg/kg twice daily).

The carcinogenic potential of tofacitinib was assessed in 6-month rasH2 transgenic mouse carcinogenicity and 2-year rat carcinogenicity studies. Tofacitinib, at exposure levels approximately 34 times the recommended dose of 5 mg twice daily, and approximately 17 times the 10 mg twice daily dose (on an AUC basis at oral doses of 200 mg/kg/day) was not carcinogenic in mice.

In the 24-month oral carcinogenicity study in Sprague-Dawley rats, tofacitinib caused benign Leydig cell tumors, hibernomas (malignancy of brown adipose tissue), and benign thymomas at doses greater than or equal to 30 mg/kg/day (approximately 42 times the exposure levels at the recommended dose of 5 mg twice daily, and approximately 21 times the 10 mg twice daily dose on an AUC basis). The relevance of benign Leydig cell tumors to human risk is not known.

Tofacitinib was not mutagenic in the bacterial reverse mutation assay. It was positive for clastogenicity in the *in vitro* chromosome aberration assay with human lymphocytes in the presence of metabolic enzymes, but negative in the absence of metabolic enzymes. Tofacitinib was negative in the *in vivo* rat micronucleus assay and in the *in vitro* CHO-HGPRT assay and the *in vivo* rat hepatocyte unscheduled DNA synthesis assay.

In rats, tofacitinib at exposure levels approximately 17 times the recommended dose of 5 mg twice daily, and approximately 8.3 times the 10 mg twice daily dose (on an AUC basis at oral doses of 10 mg/kg/day) reduced female fertility due to increased post-implantation loss. There was no impairment of female rat fertility at exposure levels of tofacitinib equal to the recommended dose of 5 mg twice daily, and approximately 0.5 times the 10 mg twice daily dose (on an AUC basis at oral doses of 1 mg/kg/day). Tofacitinib exposure levels at approximately 133 times the recommended dose of 5 mg twice daily, and approximately 67 times the 10 mg twice daily dose (on an AUC basis at oral doses of 100 mg/kg/day) had no effect on male fertility, sperm motility, or sperm concentration.

14 CLINICAL STUDIES

14.1 Rheumatoid Arthritis

The XELJANZ clinical development program included two dose-ranging trials and five confirmatory trials. Although other doses have been studied, the recommended dose of XELJANZ is 5 mg twice daily. XELJANZ 10 mg twice daily is not recommended for the treatment of rheumatoid arthritis [*see Dosage and Administration (2.2)*].

Dose-Ranging Trials

Dose selection for XELJANZ was based on two pivotal dose-ranging trials.

Dose-Ranging Study 1 was a 6-month monotherapy trial in 384 patients with active rheumatoid arthritis who had an inadequate response to a DMARD. Patients who previously received adalimumab therapy were excluded. Patients were randomized to 1 of 7 monotherapy treatments: XELJANZ 1, 3, 5, 10 or 15 mg twice daily, adalimumab 40 mg subcutaneously every other week for 10 weeks followed by XELJANZ 5 mg twice daily for 3 months, or placebo.

Dose-Ranging Study 2 was a 6-month trial in which 507 patients with active rheumatoid arthritis who had an inadequate response to MTX alone received one of 6 dose regimens of XELJANZ (20 mg once daily; 1, 3, 5, 10 or 15 mg twice daily), or placebo added to background MTX.

The results of XELJANZ-treated patients achieving ACR20 responses in Studies 1 and 2 are shown in Figure 4. Although a dose-response relationship was observed in Study 1, the

proportion of patients with an ACR20 response did not clearly differ between the 10 mg and 15 mg doses. In Study 2, a smaller proportion of patients achieved an ACR20 response in the placebo and XELJANZ 1 mg groups compared to patients treated with the other XELJANZ doses. However, there was no difference in the proportion of responders among patients treated with XELJANZ 3, 5, 10, 15 mg twice daily or 20 mg once daily doses.

Figure 4: Proportion of Patients with ACR20 Response at Month 3 in Dose-Ranging Studies 1 and 2

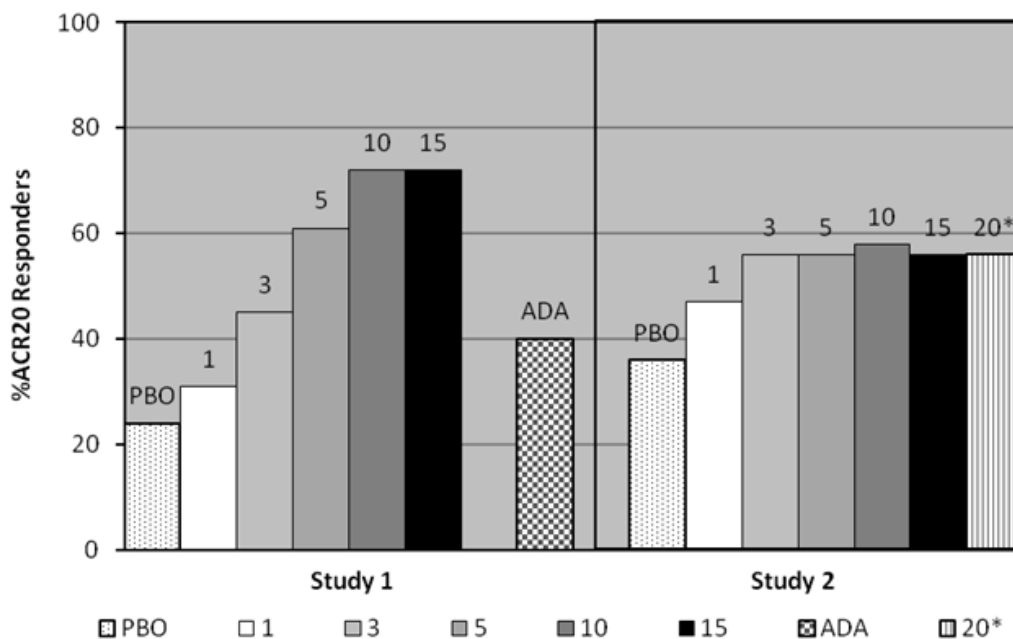

* XELJANZ twice daily dosing in mg, except for 20 mg which is once daily dosing in mg. PBO is placebo; ADA is adalimumab 40 mg subcutaneous injection every other week.

Study 1 was a dose-ranging monotherapy trial not designed to provide comparative effectiveness data and should not be interpreted as evidence of superiority to adalimumab.

Confirmatory Trials

Study RA-I (NCT00814307) was a 6-month monotherapy trial in which 610 patients with moderate to severe active rheumatoid arthritis who had an inadequate response to a DMARD (nonbiologic or biologic) received XELJANZ 5 or 10 mg twice daily or placebo. At the Month 3 visit, all patients randomized to placebo treatment were advanced in a blinded fashion to a second predetermined treatment of XELJANZ 5 or 10 mg twice daily. The primary endpoints at Month 3 were the proportion of patients who achieved an ACR20 response, changes in Health Assessment Questionnaire – Disability Index (HAQ-DI), and rates of Disease Activity Score DAS28-4(ESR) less than 2.6.

Study RA-II (NCT00856544) was a 12-month trial in which 792 patients with moderate to severe active rheumatoid arthritis who had an inadequate response to a nonbiologic DMARD received XELJANZ 5 or 10 mg twice daily or placebo added to background DMARD treatment (excluding potent immunosuppressive treatments such as azathioprine or cyclosporine). At the

Month 3 visit, nonresponding patients were advanced in a blinded fashion to a second predetermined treatment of XELJANZ 5 or 10 mg twice daily. At the end of Month 6, all placebo patients were advanced to their second predetermined treatment in a blinded fashion. The primary endpoints were the proportion of patients who achieved an ACR20 response at Month 6, changes in HAQ-DI at Month 3, and rates of DAS28-4(ESR) less than 2.6 at Month 6.

Study RA-III (NCT00853385) was a 12-month trial in 717 patients with moderate to severe active rheumatoid arthritis who had an inadequate response to MTX. Patients received XELJANZ 5 or 10 mg twice daily, adalimumab 40 mg subcutaneously every other week, or placebo added to background MTX. Placebo patients were advanced as in Study II. The primary endpoints were the proportion of patients who achieved an ACR20 response at Month 6, HAQ-DI at Month 3, and DAS28-4(ESR) less than 2.6 at Month 6.

Study RA-IV (NCT00847613) was a 2-year trial with a planned analysis at 1 year in which 797 patients with moderate to severe active rheumatoid arthritis who had an inadequate response to MTX received XELJANZ 5 or 10 mg twice daily or placebo added to background MTX. Placebo patients were advanced as in Study II. The primary endpoints were the proportion of patients who achieved an ACR20 response at Month 6, mean change from baseline in van der Heijde-modified total Sharp Score (mTSS) at Month 6, HAQ-DI at Month 3, and DAS28-4(ESR) less than 2.6 at Month 6.

Study RA-V (NCT00960440) was a 6-month trial in which 399 patients with moderate to severe active rheumatoid arthritis who had an inadequate response to at least one approved TNF blocking biologic agent received XELJANZ 5 or 10 mg twice daily or placebo added to background MTX. At the Month 3 visit, all patients randomized to placebo treatment were advanced in a blinded fashion to a second predetermined treatment of XELJANZ 5 or 10 mg twice daily. The primary endpoints at Month 3 were the proportion of patients who achieved an ACR20 response, HAQ-DI, and DAS28-4(ESR) less than 2.6.

Study RA-VI (NCT01039688) was a 2-year monotherapy trial with a planned analysis at 1 year in which 952 MTX-naïve patients with moderate to severe active rheumatoid arthritis received XELJANZ 5 or 10 mg twice daily or MTX dose-titrated over 8 weeks to 20 mg weekly. The primary endpoints were mean change from baseline in van der Heijde-modified Total Sharp Score (mTSS) at Month 6 and the proportion of patients who achieved an ACR70 response at Month 6.

Clinical Response

The percentages of XELJANZ-treated patients achieving ACR20, ACR50, and ACR70 responses in Studies RA-I, IV, and V are shown in Table 8. Similar results were observed with Studies RA-II and III. In trials RA-I through V, patients treated with 5 mg twice daily XELJANZ had higher ACR20, ACR50, and ACR70 response rates versus placebo, with or without background DMARD treatment, at Month 3 and Month 6. Higher ACR20 response rates were observed within 2 weeks compared to placebo. In the 12-month trials, ACR response rates in XELJANZ-treated patients were consistent at 6 and 12 months.

Table 8: Proportion of Patients with an ACR Response

	Percent of Patients					
	Monotherapy in Nonbiologic or Biologic DMARD Inadequate Responders ^c		MTX Inadequate Responders ^d		TNF Blocker Inadequate Responders ^e	
	Study I		Study IV		Study V	
N ^a	PBO	XELJANZ 5 mg Twice Daily	PBO + MTX	XELJANZ 5 mg Twice Daily + MTX	PBO + MTX	XELJANZ 5 mg Twice Daily + MTX
	122	243	160	321	132	133
ACR20 Month 3 Month 6	26% NA ^b	59% 69%	27% 25%	55% 50%	24% NA	41% 51%
ACR50 Month 3 Month 6	12% NA	31% 42%	8% 9%	29% 32%	8% NA	26% 37%
ACR70 Month 3 Month 6	6% NA	15% 22%	3% 1%	11% 14%	2% NA	14% 16%

^a N is number of randomized and treated patients.

^b NA Not applicable, as data for placebo treatment is not available beyond 3 months in Studies I and V due to placebo advancement.

^c Inadequate response to at least one DMARD (biologic or nonbiologic) due to lack of efficacy or toxicity.

^d Inadequate response to MTX defined as the presence of sufficient residual disease activity to meet the entry criteria.

^e Inadequate response to a least one TNF blocker due to lack of efficacy and/or intolerance.

In Study RA-IV, a greater proportion of patients treated with XELJANZ 5 mg twice daily plus MTX achieved a low level of disease activity as measured by a DAS28-4(ESR) less than 2.6 at 6 months compared to those treated with MTX alone (Table 9).

Table 9: Proportion of Patients with DAS28-4(ESR) Less Than 2.6 with Number of Residual Active Joints

DAS28-4(ESR) Less Than 2.6	Study IV	
	Placebo + MTX	XELJANZ 5 mg Twice Daily + MTX
	160	321
Proportion of responders at Month 6 (n)	1% (2)	6% (19)
Of responders, proportion with 0 active joints (n)	50% (1)	42% (8)
Of responders, proportion with 1 active joint (n)	0	5% (1)
Of responders, proportion with 2 active joints (n)	0	32% (6)
Of responders, proportion with 3 or more active joints (n)	50% (1)	21% (4)

The results of the components of the ACR response criteria for Study RA-IV are shown in Table 10. Similar results were observed for XELJANZ in Studies RA-I, II, III, V, and VI.

Table 10: Components of ACR Response at Month 3

Component (mean) ^a	Study IV			
	XELJANZ 5 mg Twice Daily + MTX		Placebo + MTX	
	N=321		N=160	
	Baseline	Month 3 ^a	Baseline	Month 3 ^a
Number of tender joints (0-68)	24 (14)	13 (14)	23 (13)	18 (14)
Number of swollen joints (0-66)	14 (8)	6 (8)	14 (9)	10 (9)
Pain ^b	58 (23)	34 (23)	55 (24)	47 (24)
Patient global assessment ^b	58 (24)	35 (23)	54 (23)	47 (24)
Disability index (HAQ-DI) ^c	1.41 (0.68)	0.99 (0.65)	1.32 (0.67)	1.19 (0.68)
Physician global assessment ^b	59 (16)	30 (19)	56 (18)	43 (22)
CRP (mg/L)	15.3 (19.0)	7.1 (19.1)	13.7 (14.9)	14.6 (18.7)

^a Data shown is mean (Standard Deviation) at Month 3.

^b Visual analog scale: 0 = best, 100 = worst.

^c Health Assessment Questionnaire Disability Index: 0 = best, 3 = worst; 20 questions; categories: dressing and grooming, arising, eating, walking, hygiene, reach, grip, and activities.

The percent of ACR20 responders by visit for Study RA-IV is shown in Figure 5. Similar responses were observed for XELJANZ in Studies RA-I, II, III, V, and VI.

Figure 5: Percentage of ACR20 Responders by Visit for Study RA-IV

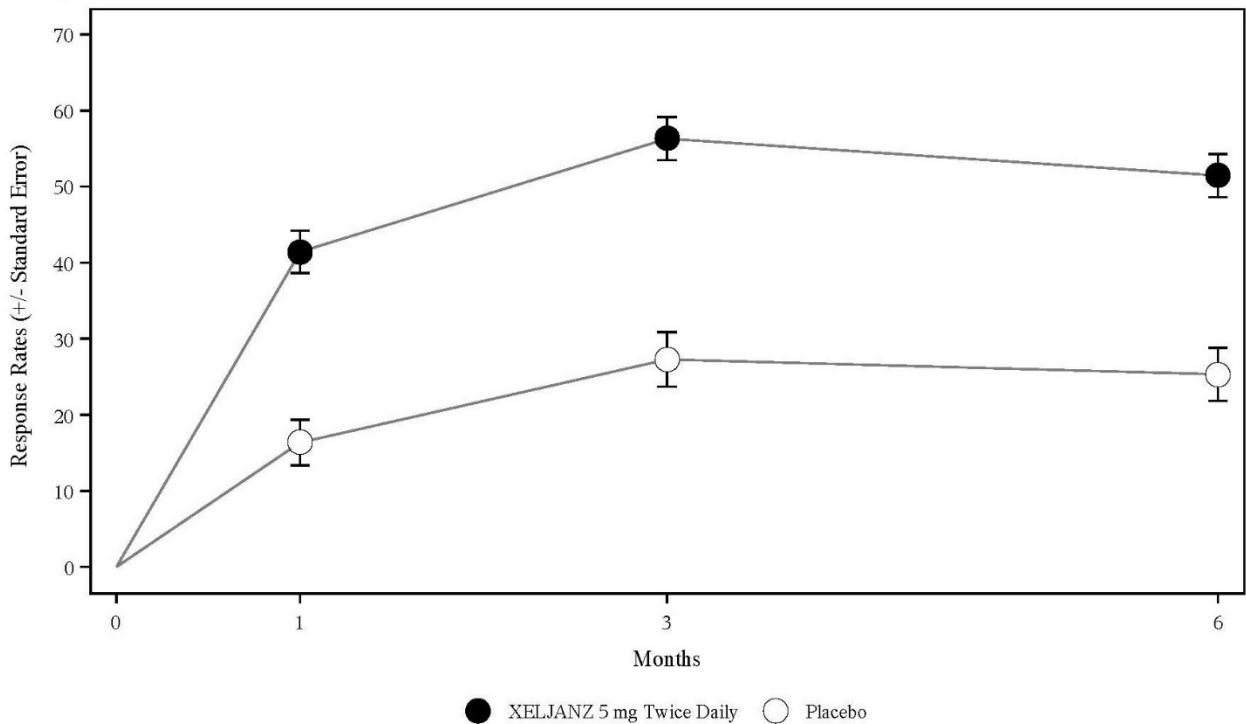

Non-responder imputation was used. Patients who withdrew from the study were counted as failures, as were patients who failed to have at least a 20% improvement in joint counts at Month 3.

Radiographic Response

Two studies were conducted to evaluate the effect of XELJANZ on structural joint damage. In Study RA-IV and Study RA-VI, progression of structural joint damage was assessed radiographically and expressed as change from baseline in mTSS and its components, the erosion score and joint space narrowing score, at Months 6 and 12. The proportion of patients with no radiographic progression (mTSS change less than or equal to 0) was also assessed.

In Study RA-IV, XELJANZ 5 mg twice daily reduced the mean progression of structural damage (not statistically significant) as shown in Table 10. Analyses of erosion and joint space narrowing scores were consistent with the overall results.

In the placebo plus MTX group, 74% of patients experienced no radiographic progression at Month 6 compared to 84% of patients treated with XELJANZ plus MTX 5 mg twice daily.

In Study RA-VI, XELJANZ monotherapy inhibited the progression of structural damage compared to MTX at Months 6 and 12 as shown in Table 10. Analyses of erosion and joint space narrowing scores were consistent with the overall results.

In the MTX group, 55% of patients experienced no radiographic progression at Month 6 compared to 73% of patients treated with XELJANZ 5 mg twice daily.

Table 11: Radiographic Changes at Months 6 and 12

	Study IV		
	Placebo N=139 Mean (SD) ^a	XELJANZ 5 mg Twice Daily N=277 Mean (SD) ^a	XELJANZ 5 mg Twice Daily Mean Difference from Placebo ^b (CI)
mTSS ^c Baseline Month 6	33 (42) 0.5 (2.0)	31 (48) 0.1 (1.7)	- -0.3 (-0.7, 0.0)
	Study VI		
	MTX N=166 Mean (SD) ^a	XELJANZ 5 mg Twice Daily N=346 Mean (SD) ^a	XELJANZ 5 mg Twice Daily Mean Difference from MTX ^b (CI)
mTSS ^c Baseline Month 6 Month 12	17 (29) 0.8 (2.7) 1.3 (3.7)	20 (40) 0.2 (2.3) 0.4 (3.0)	- -0.7 (-1.0, -0.3) -0.9 (-1.4, -0.4)

^aSD = Standard Deviation

^bDifference between least squares means XELJANZ minus placebo or MTX (95% CI = 95% confidence interval)

^cMonth 6 and Month 12 data are mean change from baseline.

Physical Function Response

Improvement in physical functioning was measured by the HAQ-DI. Patients receiving XELJANZ 5 mg twice daily demonstrated greater improvement from baseline in physical functioning compared to placebo at Month 3.

The mean (95% CI) difference from placebo in HAQ-DI improvement from baseline at Month 3 in Study RA-III was -0.22 (-0.35, -0.10) in patients receiving 5 mg XELJANZ twice daily. Similar results were obtained in Studies RA-I, II, IV and V. In the 12-month trials, HAQ-DI results in XELJANZ-treated patients were consistent at 6 and 12 months.

Other Health-Related Outcomes

General health status was assessed by the Short Form health survey (SF-36). In Studies RA-I, IV, and V, patients receiving XELJANZ 5 mg twice daily demonstrated greater improvement from baseline compared to placebo in physical component summary (PCS), mental component summary (MCS) scores and in all 8 domains of the SF-36 at Month 3.

14.2 Psoriatic Arthritis

The XELJANZ clinical development program to assess efficacy and safety included 2 multicenter, randomized, double-blind, placebo-controlled confirmatory trials in 816 patients 18 years of age and older (PsA-I and PsA-II). Although other doses have been studied, the recommended dose of XELJANZ is 5 mg twice daily. XELJANZ 10 mg twice daily is not recommended for the treatment of psoriatic arthritis [see *Dosage and Administration* (2.2)]. All patients had active psoriatic arthritis for at least 6 months based upon the Classification Criteria for Psoriatic Arthritis (CASPAR), at least 3 tender/painful joints and at least 3 swollen joints, and active plaque psoriasis. Patients randomized and treated across the 2 clinical trials represented different psoriatic arthritis subtypes at screening, including <5 joints or asymmetric

involvement (21%), ≥ 5 joints involved (90%), distal interphalangeal (DIP) joint involvement (61%), arthritis mutilans (8%), and spondylitis (19%). Patients in these clinical trials had a diagnosis of psoriatic arthritis for a mean (SD) of 7.7 (7.2) years. At baseline, 80% and 53% of patients had enthesitis and dactylitis, respectively. At baseline, all patients were required to receive treatment with a stable dose of a nonbiologic DMARD (79% received methotrexate, 13% received sulfasalazine, 7% received leflunomide, 1% received other nonbiologic DMARDs). In both clinical trials, the primary endpoints were the ACR20 response and the change from baseline in HAQ-DI at Month 3.

Study PsA-I was a 12-month clinical trial in 422 patients who had an inadequate response to a nonbiologic DMARD (67% and 33% were inadequate responders to 1 nonbiologic DMARD and ≥ 2 nonbiologic DMARDs, respectively) and who were naïve to treatment with a TNF blocker. Patients were randomized in a 2:2:2:1:1 ratio to receive XELJANZ 5 mg twice daily, XELJANZ 10 mg twice daily, adalimumab 40 mg subcutaneously once every 2 weeks, placebo to XELJANZ 5 mg twice daily treatment sequence, or placebo to XELJANZ 10 mg twice daily treatment sequence, respectively; study drug was added to background nonbiologic DMARD treatment. At the Month 3 visit, all patients randomized to placebo treatment were advanced in a blinded fashion to a predetermined XELJANZ dose of 5 mg or 10 mg twice daily. Study PsA-I was not designed to demonstrate noninferiority or superiority to adalimumab.

Study PsA-II was a 6-month clinical trial in 394 patients who had an inadequate response to at least 1 approved TNF blocker (66%, 19%, and 15% were inadequate responders to 1 TNF blocker, 2 TNF blockers and ≥ 3 TNF blockers, respectively). Patients were randomized in a 2:2:1:1 ratio to receive XELJANZ 5 mg twice daily, XELJANZ 10 mg twice daily, placebo to XELJANZ 5 mg twice daily treatment sequence, or placebo to XELJANZ 10 mg twice daily treatment sequence, respectively; study drug was added to background nonbiologic DMARD treatment. At the Month 3 visit, placebo patients were advanced in a blinded fashion to a predetermined XELJANZ dose of 5 mg or 10 mg twice daily as in Study PsA-I.

Clinical Response

At Month 3, patients treated with XELJANZ 5 mg twice daily had higher ($p \leq 0.05$) response rates versus placebo for ACR20, ACR50, and ACR70 in Study PsA-I and for ACR20 and ACR50 in Study PsA-II; ACR70 response rates were also higher for XELJANZ 5 mg twice daily versus placebo in Study PsA-II, although the differences versus placebo were not statistically significant ($p > 0.05$) (Tables 12 and 13).

Table 12: Proportion of Patients with an ACR Response in Study PsA-I* [Nonbiologic DMARD Inadequate Responders (TNF Blocker-Naïve)]

Treatment Group	Placebo	XELJANZ 5 mg Twice Daily	
N ^a	105	107	
	Response Rate	Response Rate	Difference (%) 95% CI from Placebo
Month 3			
ACR20	33%	50%	17.1 (4.1, 30.2)
ACR50	10%	28%	18.5 (8.3, 28.7)
ACR70	5%	17%	12.1 (3.9, 20.2)

Subjects with missing data were treated as non-responders.

* Subjects received one concomitant nonbiologic DMARD.

^a N is number of randomized and treated patients.

Table 13: Proportion of Patients with an ACR Response in Study PsA-II* (TNF Blocker Inadequate Responders)

Treatment Group	Placebo	XELJANZ 5 mg Twice Daily	
N ^a	131	131	
	Response Rate	Response Rate	Difference (%) 95% CI from Placebo
Month 3			
ACR20	24%	50%	26.0 (14.7, 37.2)
ACR50	15%	30%	15.3 (5.4, 25.2)
ACR70	10%	17%	6.9 (-1.3, 15.1)

Subjects with missing data were treated as non-responders.

* Subjects received one concomitant nonbiologic DMARD.

^a N is number of randomized and treated patients.

Improvements from baseline in the ACR response criteria components for both studies are shown in Table 14.

Table 14: Components of ACR Response at Baseline and Month 3 in Studies PsA-I and PsA-II

	Nonbiologic DMARD Inadequate Responders (TNF Blocker-Naïve)		TNF Blocker Inadequate Responders	
	Study PsA-I*		Study PsA-II*	
Treatment Group	Placebo	XELJANZ 5 mg Twice Daily	Placebo	XELJANZ 5 mg Twice Daily
N at Baseline	105	107	131	131
ACR Component ^a				
Number of tender/painful joints (0-68)				
Baseline	20.6	20.5	19.8	20.5
Month 3	14.6	12.2	15.1	11.5
Number of swollen joints (0-66)				
Baseline	11.5	12.9	10.5	12.1
Month 3	7.1	6.3	7.7	4.8
Patient assessment of arthritis pain ^b				
Baseline	53.2	55.7	54.9	56.4
Month 3	44.7	34.7	48.0	36.1
Patient global assessment of arthritis ^b				
Baseline	53.9	54.7	55.8	57.4
Month 3	44.4	35.5	49.2	36.9
HAQ-DI ^c				
Baseline	1.11	1.16	1.25	1.26
Month 3	0.95	0.81	1.09	0.88
Physician's Global Assessment of Arthritis ^b				
Baseline	53.8	54.6	53.7	53.5
Month 3	35.4	29.5	36.4	27.0
CRP (mg/L)				
Baseline	10.4	10.5	12.1	13.8
Month 3	8.6	4.0	11.4	7.7

* Subjects received one concomitant nonbiologic DMARD.

^a Data shown are mean value at baseline and at Month 3.

^b Visual analog scale (VAS): 0 = best, 100 = worst.

^c HAQ-DI = Health Assessment Questionnaire – Disability Index: 0 = best, 3 = worst; 20 questions; categories: dressing and grooming, arising, eating, walking, hygiene, reach, grip, and activities.

The percentage of ACR20 responders by visit for Study PsA-I is shown in Figure 6. Similar responses were observed in Study PsA-II. In both studies, improvement in ACR20 response on XELJANZ was observed at the first visit after baseline (Week 2).

Figure 6: Percentage of ACR20 Responders by Visit Through Month 3 in Study PsA-I*

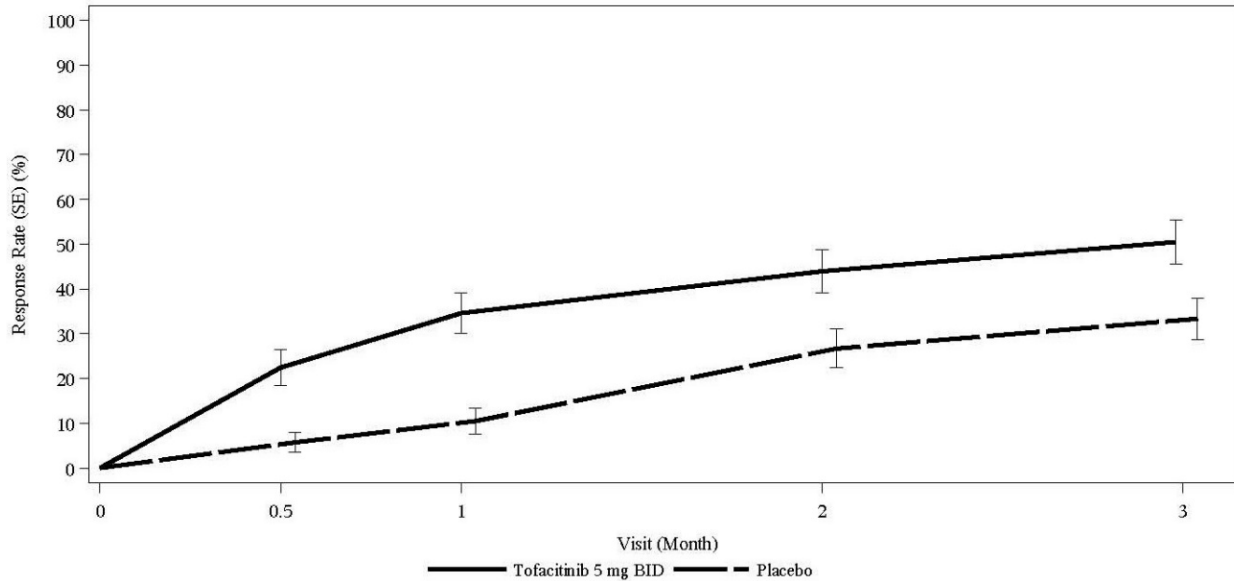

BID=twice daily; SE=standard error.

Subjects with missing data were treated as non-responders.

* Subjects received one concomitant nonbiologic DMARD.

In patients with active psoriatic arthritis evidence of benefit in enthesitis and dactylitis was observed with XELJANZ treatment.

Physical Function

Improvement in physical functioning was measured by the HAQ-DI. Patients receiving XELJANZ 5 mg twice daily demonstrated significantly greater improvement ($p \leq 0.05$) from baseline in physical functioning compared to placebo at Month 3 (Table 15).

Table 15: Change from Baseline in HAQ-DI in Studies PsA-I and PsA-II

Treatment Group	Least Squares Mean Change from Baseline In HAQ-DI at Month 3			
	Nonbiologic DMARD Inadequate Responders ^b (TNF Blocker-Naïve)		TNF Blocker Inadequate Responders ^c	
	Study PsA-I*		Study PsA-II*	
	Placebo	XELJANZ 5 mg Twice Daily	Placebo	XELJANZ 5 mg Twice Daily
N ^a	104	107	131	129
LSM Change from Baseline	-0.18	-0.35	-0.14	-0.39
Difference from Placebo (95% CI)	-	-0.17 (-0.29, -0.05)	-	-0.25 (-0.38, -0.13)

* Subjects received one concomitant nonbiologic DMARD.

^a N is the total number of subjects in the statistical analysis.

^b Inadequate response to at least one nonbiologic DMARD due to lack of efficacy and/or intolerability.

^c Inadequate response to at least one TNF blocker due to lack of efficacy and/or intolerability.

In Study PsA-I, the HAQ-DI responder rate (response defined as having improvement from baseline of ≥ 0.35) at Month 3 was 53% in patients receiving XELJANZ 5 mg twice daily and 31% in patients receiving placebo. Similar responses were observed in Study PsA-II.

Other Health-Related Outcomes

General health status was assessed by the Short Form health survey (SF-36). In Studies PsA-I and PsA-II, patients receiving XELJANZ 5 mg twice daily had greater improvement from baseline compared to placebo in Physical Component Summary (PCS) score, but not in Mental Component Summary (MCS) score at Month 3. Patients receiving XELJANZ 5 mg twice daily reported consistently greater improvement relative to placebo in the domains of Physical Functioning, Bodily Pain, Vitality, and Social Functioning, but not in Role Physical, General Health, Role Emotional, or Mental Health.

Radiographic Response

Treatment effect on inhibition of radiographic progression in psoriatic arthritis could not be established from the results of Study PsA-I.

14.3 Ulcerative Colitis

Induction Trials (Study UC-I [NCT01465763] and Study UC-II [NCT01458951])

In two identical induction trials (UC-I and UC-II), 1139 patients were randomized (598 and 541 patients, respectively) to XELJANZ 10 mg twice daily or placebo with a 4:1 treatment allocation ratio. These trials included adult patients with moderately to severely active UC (total Mayo score of 6 to 12, with an endoscopy subscore of at least 2, and rectal bleeding subscore of at least 1) and who had failed or were intolerant to at least 1 of the following treatments: oral or intravenous corticosteroids, azathioprine, 6-MP or TNF blocker. XELJANZ is indicated for patients who have an inadequate response or who are intolerant to TNF blockers [*see Indications and Usage (1)*].

The disease activity was assessed by Mayo scoring index (0 to 12) which consists of four subscores (0 to 3 for each subscore): stool frequency, rectal bleeding, findings on endoscopy, and physician global assessment. An endoscopy subscore of 2 was defined by marked erythema, absent vascular pattern, any friability, and erosions; an endoscopy subscore of 3 was defined by spontaneous bleeding and ulceration.

Patients were permitted to use stable doses of oral aminosalicylates and corticosteroids (prednisone daily dose up to 25 mg equivalent). Concomitant immunosuppressants (oral immunomodulators or biologic therapies) were not permitted for UC patients during these studies.

A total of 52%, 73% and 72% of patients had previously failed or were intolerant to TNF blockers (51% in Study UC-1 and 52% in Study UC-II), corticosteroids (75% in Study UC-I and 71% in Study UC-II), and/or immunosuppressants (74% in Study UC-I and 70% in Study UC-II), respectively.

Oral corticosteroids were received as concomitant treatment for UC by 47% of patients (45% in Study UC-I and 48% in Study UC-II) and 71% were receiving concomitant aminosalicylates as treatment for UC (71% in Study UC-I, and 72% in Study UC-II). The baseline clinical characteristics were generally similar between the XELJANZ treated patients and patients receiving placebo.

The primary endpoint of Study UC-I and Study UC-II was the proportion of patients in remission at Week 8, and the key secondary endpoint was the proportion of patients with improvement of endoscopic appearance of the mucosa at Week 8.

The efficacy results of Study UC-I and Study UC-II based on the centrally read endoscopy results are shown in Table 16.

Table 16: Proportion of Patients Meeting Primary and Key Secondary Efficacy Endpoints at Week 8 (Induction Study UC-I and Study UC-II, Central Endoscopy Read)

Study UC-I			
Endpoint	Placebo	XELJANZ 10 mg Twice Daily	Treatment Difference versus Placebo (95% CI)
Remission at Week 8^a			
Total Population	N=122 8%	N=476 18%	10%* (4.3, 16.3)
With Prior TNF Blocker Failure ^b	N=64 2%	N=243 11%	
Without Prior TNF Blocker Failure ^c	N=58 16%	N=233 26%	
Improvement of endoscopic appearance of the mucosa at Week 8^d			
Total Population	N=122 16%	N=476 31%	16%** (8.1, 23.4)
With Prior TNF Blocker Failure ^b	N=64 6%	N=243 23%	
Without Prior TNF Blocker Failure ^c	N=58 26%	N=233 40%	

Study UC-II			
Endpoint	Placebo	XELJANZ 10 mg Twice Daily	Treatment Difference (95% CI)
Remission at Week 8^a			
Total Population	N=112 4%	N=429 17%	13%** (8.1, 17.9)
With Prior TNF Blocker Failure ^b	N=60 0%	N=222 12%	
Without Prior TNF Blocker Failure ^c	N=52 8%	N=207 22%	
Improvement of endoscopic appearance of the mucosa at Week 8^d			
Total Population	N=112 12%	N=429 28%	17%** (9.5, 24.1)
With Prior TNF Blocker Failure ^b	N=60 7%	N=222 22%	
Without Prior TNF Blocker Failure ^c	N=52 17%	N=207 36%	

* p-value <0.01, ** p-value <0.001.

CI = Confidence interval; N = number of patients in the analysis set; TNF = tumor necrosis factor

^a Remission was defined as clinical remission (a Mayo score ≤ 2 with no individual subscore > 1) and rectal bleeding subscore of 0.

^b Prior TNF blocker failure was defined in this program as inadequate response, loss of response, or intolerance to TNF blocker therapy.

^c Patients in this group had failed one or more conventional therapies (corticosteroid, azathioprine, 6-mercaptopurine) but did not have history of prior failure of TNF blocker therapy.

^d Improvement of endoscopic appearance of the mucosa was defined as Mayo endoscopy subscore of 0 (normal or inactive disease) or 1 (erythema, decreased vascular pattern).

Clinical Response at Week 8

Clinical response was defined as a decrease from baseline in Mayo score of ≥ 3 points and $\geq 30\%$, with an accompanying decrease in the subscore for rectal bleeding of ≥ 1 point or absolute subscore for rectal bleeding of 0 or 1.

Clinical response was observed in 60% of patients treated with XELJANZ 10 mg twice daily compared to 33% of placebo patients in Study UC-I and 55% compared to 29% in Study UC-II.

Normalization of the Endoscopic Appearance of the Mucosa at Week 8

Normalization of endoscopic appearance of the mucosa was defined as a Mayo endoscopic subscore of 0 and was observed in 7% of patients treated with XELJANZ 10 mg twice daily compared to 2% of placebo patients in both Studies UC-I and UC-II.

Rectal Bleeding and Stool Frequency

Decreases in rectal bleeding and stool frequency subscores were observed as early as Week 2 in patients treated with XELJANZ.

Maintenance Trial (Study UC-III [NCT01458574])

A total of 593 patients who completed the induction trials (UC-I or UC-II) and achieved clinical response were re-randomized with 1:1:1 treatment allocation ratio to XELJANZ 5 mg twice daily, XELJANZ 10 mg twice daily, or placebo for 52 weeks in Study UC-III. XELJANZ 5 mg twice daily is the recommended dosage for maintenance therapy; limit use of XELJANZ 10 mg twice daily beyond induction to those with loss of response and should be used for the shortest duration [see *Dosage and Administration (2.3)*]. As in the induction trials, patients were permitted to use stable doses of oral aminosalicylates; however, corticosteroid tapering was required upon entrance into this study for patients who were receiving corticosteroids at baseline. Concomitant immunosuppressants (oral immunomodulators or biologic therapies) were not permitted.

At baseline of Study UC-III:

- 179 (30%) patients were in remission
- 289 (49%) patients were receiving oral corticosteroids
- 265 (45%), 445 (75%), and 413 (70%) patients had previously failed or were intolerant to TNF blocker therapy, corticosteroids, and immunosuppressants, respectively.

The primary endpoint was the proportion of patients in remission at Week 52. There were 2 key secondary endpoints: the proportion of patients with improvement of endoscopic appearance at Week 52, and the proportion of patients with sustained corticosteroid-free remission at both Week 24 and Week 52 among patients in remission at baseline of Study UC-III.

The efficacy results of Study UC-III based on the centrally read endoscopy results are summarized in Table 17.

Table 17: Proportion of Patients Meeting Primary and Key Secondary Efficacy Endpoints in Maintenance Study UC-III (Central Endoscopy Read)

Endpoint	Placebo	XELJANZ 5 mg Twice Daily	XELJANZ 10 mg Twice Daily	Treatment Difference versus Placebo (95% CI)	
				XELJANZ 5 mg Twice Daily	XELJANZ 10 mg Twice Daily
Remission at Week 52^a					
Total Population	N=198 11%	N=198 34%	N=197 41%	23%* (15.3, 31.2)	30%* (21.4, 37.6)
With Prior TNF Blocker Failure ^b	N=89 11%	N=83 24%	N=93 37%		
Without Prior TNF Blocker Failure ^c	N=109 11%	N=115 42%	N=104 44%		
Improvement of endoscopic appearance of the mucosa at Week 52^d					
Total Population	N=198 13%	N=198 37%	N=197 46%	24%* (16.0, 32.5)	33%* (24.2, 41.0)
With Prior TNF Blocker Failure ^b	N=89 12%	N=83 30%	N=93 40%		
Without Prior TNF Blocker Failure ^c	N=109 14%	N=115 43%	N=104 51%		
Sustained corticosteroid-free remission at both Week 24 and Week 52 among patients in remission at baseline^e					
Total Population	N=59 5%	N=65 35%	N=55 47%	30%* (17.4, 43.2)	42%* (27.9, 56.5)
With Prior TNF Blocker Failure ^b	N=21 5%	N=18 22%	N=18 39%		
Without Prior TNF Blocker Failure ^c	N=38 5%	N=47 40%	N=37 51%		

* p-value <0.0001.

CI = Confidence interval; N = number of patients in the analysis set; TNF = tumor necrosis factor.

^a Remission was defined as clinical remission (a Mayo score ≤ 2 with no individual subscore > 1) and rectal bleeding subscore of 0.

^b Prior TNF blocker failure was defined in this program as inadequate response, loss of response, or intolerance to TNF blocker therapy.

^c Patients in this group had failed one or more conventional therapies (corticosteroid, azathioprine, 6-mercaptopurine) but did not have history of prior failure of TNF blocker therapy.

^d Improvement of endoscopic appearance of the mucosa was defined as Mayo endoscopy subscore of 0 (normal or inactive disease) or 1 (erythema, decreased vascular pattern).

^e Sustained corticosteroid-free remission was defined as being in remission and not taking corticosteroids for at least 4 weeks prior to the visit at both Week 24 and Week 52.

Maintenance of Clinical Response

Maintenance of clinical response was defined as the proportion of patients who met the definition of clinical response (defined as a decrease from the induction study (UC-I, UC-II) baseline Mayo score of ≥ 3 points and $\geq 30\%$, with an accompanying decrease in the rectal bleeding subscore of ≥ 1 point or rectal bleeding subscore of 0 or 1) at both Baseline and Week 52 of Study UC-III.

Maintenance of clinical response was observed in 52% in the XELJANZ 5 mg twice daily group and 62% in the XELJANZ 10 mg twice daily group compared to 20% of placebo patients.

Maintenance of Remission (Among Patients in Remission at Baseline)

In the 179 patients who were in remission at baseline of Study UC-III (N = 59 for placebo, N = 65 for XELJANZ 5 mg twice daily, N = 55 for XELJANZ 10 mg twice daily), 46% in the XELJANZ 5 mg twice daily group and 56% in the XELJANZ 10 mg twice daily group maintained remission at Week 52 compared to 10% of placebo patients.

Normalization of the Endoscopic Appearance of the Mucosa

Normalization of endoscopic appearance of the mucosa was defined as a Mayo endoscopic subscore of 0 and was observed at Week 52 in 15% of patients in the XELJANZ 5 mg twice daily group and 17% of patients in the XELJANZ 10 mg twice daily group compared to 4% of placebo patients.

Open-label Extension Study (Study UC-IV [NCT01470612])

In Study UC-IV, 914 patients were treated of which 156 received 5 mg twice daily and 758 received 10 mg twice daily.

Of the 905 patients who were assigned to XELJANZ 10 mg twice daily in the 8-week induction studies (Study UC-I or Study UC-II), 322 patients completed the induction studies but did not achieve clinical response. Of these 322 patients, 291 continued to receive XELJANZ 10 mg twice daily (unblinded) and had available data after an additional 8 weeks in Study UC-IV. After 8 additional weeks (a total of 16 weeks treatment), 148 patients achieved clinical response, and 25 patients achieved remission (based on central endoscopy read). Among those 143 patients who achieved clinical response by 16 weeks and had available data at Week 52, 66 patients achieved remission (based on local endoscopy read) after continued treatment with XELJANZ 10 mg twice daily for 52 weeks.

16 HOW SUPPLIED/STORAGE AND HANDLING

	Bottle Size (number of tablets)	NDC Number
XELJANZ 5 mg tofacitinib tablets White, round, immediate-release film-coated tablets, debossed with “Pfizer” on one side, and “JKI 5” on the other side	28	NDC 0069-1001-03
	60	NDC 0069-1001-01
XELJANZ 10 mg tofacitinib tablets Blue, round, immediate-release film-coated tablets, debossed with “Pfizer” on one side, and “JKI 10” on the other side	28	NDC 0069-1002-03
	60	NDC 0069-1002-01
	180	NDC 0069-1002-02
XELJANZ XR 11 mg tofacitinib tablets Pink, oval, extended-release film-coated tablets with a drilled hole at one end of the tablet band and “JKI 11” printed on one side of the tablet	14	NDC 0069-0501-14
	30	NDC 0069-0501-30
XELJANZ XR 22 mg tofacitinib tablets Beige, oval, extended-release film-coated tablets with a drilled hole at one end of the tablet band and “JKI 22” printed on one side of the tablet	30	NDC 0069-0502-30

Store XELJANZ/XELJANZ XR at 20°C to 25°C (68°F to 77°F). [See USP Controlled Room Temperature].

XELJANZ/XELJANZ XR

Do not repackage.

17 PATIENT COUNSELING INFORMATION

Advise the patient to read the FDA-approved patient labeling (Medication Guide).

Serious Infections

Inform patients that XELJANZ/XELJANZ XR may lower the ability of their immune system to fight infections. Advise patients not to start taking XELJANZ/XELJANZ XR if they have an active infection. Instruct patients to contact their healthcare provider immediately during treatment if symptoms suggesting infection appear in order to ensure rapid evaluation and appropriate treatment [see *Warnings and Precautions (5.1)*].

Advise patients that the risk of herpes zoster, some cases of which can be serious, is increased in patients treated with XELJANZ/XELJANZ XR [see *Warnings and Precautions (5.1)*].

Malignancies and Lymphoproliferative Disorders

Inform patients that XELJANZ/XELJANZ XR may increase their risk of certain cancers, and that lymphoma and other cancers have been observed in patients taking XELJANZ. Instruct patients to inform their healthcare provider if they have ever had any type of cancer [see *Warnings and Precautions (5.3)*].

Thrombosis

Advise patients to stop taking XELJANZ/XELJANZ XR and to call their healthcare provider right away if they experience any symptoms of thrombosis (sudden shortness of breath, chest pain worsened with breathing, swelling of leg or arm, leg pain or tenderness, red or discolored skin in the affected leg or arm) [see *Warnings and Precautions (5.4)*].

Hypersensitivity

Advise patients to stop taking XELJANZ/XELJANZ XR and to call their healthcare provider right away if they experience any symptoms of allergic reactions while taking XELJANZ/XELJANZ XR [see *Warnings and Precautions (5.6)*].

Important Information on Laboratory Abnormalities

Inform patients that XELJANZ/XELJANZ XR may affect certain lab test results, and that blood tests are required before and during XELJANZ/XELJANZ XR treatment [see *Warnings and Precautions (5.7)*].

Pregnancy

Advise pregnant women and females of reproductive potential of the potential risk to a fetus. Advise females to inform their prescriber of a known or suspected pregnancy. Inform patients that Pfizer has a registry for pregnant women who have taken XELJANZ/XELJANZ XR during pregnancy. Advise patients to contact the registry at 1-877-311-8972 to enroll [see *Use in Specific Populations (8.1)*].

Lactation

Advise women not to breastfeed during treatment with XELJANZ/XELJANZ XR and for at least 18 hours after the last dose of XELJANZ or 36 hours after the last dose of XELJANZ XR [see *Use in Specific Populations (8.2)*].

Infertility

Advise females of reproductive potential that XELJANZ/XELJANZ XR may impair fertility [see *Use in Specific Populations (8.3), Nonclinical Toxicology (13.1)*]. It is not known if this effect is reversible.

Residual Tablet Shell

Patients receiving XELJANZ XR may notice an inert tablet shell passing in the stool or via colostomy. Patients should be informed that the active medication has already been absorbed by the time the patient sees the inert tablet shell.

This product's label may have been updated. For current full prescribing information, please visit www.pfizer.com.



LAB-0445-19.0

MEDICATION GUIDE

XELJANZ (ZEL' JANS')
(tofacitinib)
tablets, for oral use

XELJANZ XR (ZEL' JANS' EKS-AHR)
(tofacitinib)
extended-release tablets, for oral use

What is the most important information I should know about XELJANZ/XELJANZ XR?

XELJANZ/XELJANZ XR may cause serious side effects including:

1. Serious infections. XELJANZ/XELJANZ XR is a medicine that affects your immune system. XELJANZ/XELJANZ XR can lower the ability of your immune system to fight infections. Some people can have serious infections while taking XELJANZ/XELJANZ XR, including tuberculosis (TB), and infections caused by bacteria, fungi, or viruses that can spread throughout the body. Some people have died from these infections.

- Your healthcare provider should test you for TB before starting XELJANZ/XELJANZ XR and during treatment.
- Your healthcare provider should monitor you closely for signs and symptoms of TB infection during treatment with XELJANZ/XELJANZ XR.

You should not start taking XELJANZ/XELJANZ XR if you have any kind of infection unless your healthcare provider tells you it is okay. You may be at a higher risk of developing shingles (herpes zoster).

People taking the higher dose of XELJANZ (10 mg twice daily) or XELJANZ XR (22 mg one time each day) have a higher risk of serious infections and shingles.

Before starting XELJANZ/XELJANZ XR, tell your healthcare provider if you:

- think you have an infection or have symptoms of an infection such as:
 - fever, sweating, or chills
 - cough
 - blood in phlegm
 - warm, red, or painful skin or sores on your body
 - burning when you urinate or urinating more often than normal
 - muscle aches
 - shortness of breath
 - weight loss
 - diarrhea or stomach pain
 - feeling very tired
- are being treated for an infection.
- get a lot of infections or have infections that keep coming back.
- have diabetes, chronic lung disease, HIV, or a weak immune system. People with these conditions have a higher chance for infections.
- have TB, or have been in close contact with someone with TB.
- live or have lived, or have traveled to certain parts of the country (such as the Ohio and Mississippi River valleys and the Southwest) where there is an increased chance for getting certain kinds of fungal infections (histoplasmosis, coccidioidomycosis, or blastomycosis). These infections may happen or become more severe if you use XELJANZ/XELJANZ XR. Ask your healthcare provider if you do not know if you have lived in an area where these infections are common.
- have or have had hepatitis B or C.

After starting XELJANZ/XELJANZ XR, call your healthcare provider right away if you have any symptoms of an infection. XELJANZ/XELJANZ XR can make you more likely to get infections or make worse any infection that you have.

2. Increased risk of death in people 50 years of age and older with rheumatoid arthritis who have at least 1 heart disease (cardiovascular) risk factor and who are taking a higher than recommended dose of XELJANZ/XELJANZ XR. The recommended dose in patients with rheumatoid arthritis and psoriatic arthritis is XELJANZ 5 mg twice daily or XELJANZ XR 11 mg one time each day.

3. Cancer and immune system problems. XELJANZ/XELJANZ XR may increase your risk of certain cancers by changing the way your immune system works.

- Lymphoma and other cancers including skin cancers can happen in patients taking XELJANZ/XELJANZ XR. People taking the higher dose of XELJANZ (10 mg twice daily) or XELJANZ XR (22 mg one time each day) have a higher risk of skin cancers. Tell your healthcare provider if you have ever had any type of cancer.

- Some people who have taken XELJANZ with certain other medicines to prevent kidney transplant rejection have had a problem with certain white blood cells growing out of control (Epstein Barr Virus-associated post-transplant lymphoproliferative disorder).

4. Blood clots in the lungs, veins of the legs or arms, and arteries. Blood clots in the lungs (pulmonary embolism, PE), veins of the legs (deep vein thrombosis, DVT) and arteries (arterial thrombosis) have happened more often in patients with rheumatoid arthritis who are 50 years of age and older and with at least 1 heart disease (cardiovascular) risk factor taking a higher than recommended dose of XELJANZ/XELJANZ XR. The recommended dose in patients with rheumatoid arthritis and psoriatic arthritis is XELJANZ 5 mg twice daily or XELJANZ XR 11 mg one time each day. Blood clots in the lungs have also happened in patients with ulcerative colitis. Some people have died from these blood clots.

- Stop taking XELJANZ/XELJANZ XR and tell your healthcare provider right away if you develop signs and symptoms of a blood clot, such as sudden shortness of breath or difficulty breathing, chest pain, swelling of the leg or arm, leg pain or tenderness, or redness or discoloration in the leg or arm.

5. Tears (perforation) in the stomach or intestines.

- Tell your healthcare provider if you have had diverticulitis (inflammation in parts of the large intestine) or ulcers in your stomach or intestines. Some people taking XELJANZ/XELJANZ XR can get tears in their stomach or intestines. This happens most often in people who also take nonsteroidal anti-inflammatory drugs (NSAIDs), corticosteroids, or methotrexate. Tell your healthcare provider right away if you have fever and stomach-area pain that does not go away, and a change in your bowel habits.

6. Allergic reactions.

- Symptoms such as swelling of your lips, tongue, or throat, or hives (raised, red patches of skin that are often very itchy) that may mean you are having an allergic reaction have been seen in patients taking XELJANZ/XELJANZ XR. Some of these reactions were serious. If any of these symptoms occur while you are taking XELJANZ/XELJANZ XR, stop XELJANZ/XELJANZ XR and call your healthcare provider right away.

7. Changes in certain laboratory test results. Your healthcare provider should do blood tests before you start receiving XELJANZ/XELJANZ XR and while you take XELJANZ/XELJANZ XR to check for the following side effects:

- **changes in lymphocyte counts.** Lymphocytes are white blood cells that help the body fight off infections.
- **low neutrophil counts.** Neutrophils are white blood cells that help the body fight off infections.
- **low red blood cell count.** This may mean that you have anemia, which may make you feel weak and tired.

Your healthcare provider should routinely check certain liver tests.

You should not receive XELJANZ/XELJANZ XR if your lymphocyte count, neutrophil count, or red blood cell count is too low or your liver tests are too high.

Your healthcare provider may stop your XELJANZ/XELJANZ XR treatment for a period of time if needed because of changes in these blood test results.

You may also have changes in other laboratory tests, such as your blood cholesterol levels. Your healthcare provider should do blood tests to check your cholesterol levels 4 to 8 weeks after you start receiving XELJANZ/XELJANZ XR, and as needed after that. Normal cholesterol levels are important to good heart health.

See “What are the possible side effects of XELJANZ/XELJANZ XR?” for more information about side effects.

What is XELJANZ/XELJANZ XR?

XELJANZ/XELJANZ XR is a prescription medicine called a Janus kinase (JAK) inhibitor.

XELJANZ/XELJANZ XR is used to treat adults with moderately to severely active rheumatoid arthritis in whom methotrexate did not work well or cannot be tolerated.

XELJANZ/XELJANZ XR is used to treat adults with active psoriatic arthritis in which methotrexate or other similar medicines called nonbiologic disease-modifying antirheumatic drugs (DMARDs) did not work well or cannot be tolerated.

XELJANZ/XELJANZ XR is used to treat adults with moderately to severely active ulcerative colitis when medicines called tumor necrosis factor (TNF) blockers did not work well or cannot be tolerated. It is not known if XELJANZ/XELJANZ XR is safe and effective in people with Hepatitis B or C. XELJANZ/XELJANZ XR is not recommended for people with severe liver problems. It is not known if XELJANZ/XELJANZ XR is safe and effective in children.

What should I tell my healthcare provider before taking XELJANZ/XELJANZ XR?

Before taking XELJANZ/XELJANZ XR, tell your healthcare provider about all of your medical conditions, including if you:

- have an infection. See “What is the most important information I should know about XELJANZ/XELJANZ XR?”
- have had blood clots in the veins of your legs, arms, or lungs, or clots in the arteries in the past.
- have liver problems.
- have kidney problems.
- have any stomach area (abdominal) pain or been diagnosed with diverticulitis or ulcers in your stomach or intestines.
- have had a reaction to tofacitinib or any of the ingredients in XELJANZ/XELJANZ XR.
- have recently received or are scheduled to receive a vaccine. People who take XELJANZ/XELJANZ XR should not receive live vaccines. People taking XELJANZ/XELJANZ XR can receive non-live vaccines.
- plan to become pregnant or are pregnant. XELJANZ/XELJANZ XR may affect the ability of females to get pregnant. It is not known if this will change after stopping XELJANZ/XELJANZ XR. It is not known if XELJANZ/XELJANZ XR will harm an unborn baby.
 - **Pregnancy Registry:** Pfizer has a registry for pregnant women who take XELJANZ/XELJANZ XR. The purpose of this registry is to check the health of the pregnant mother and her baby. If you are pregnant or become pregnant while taking XELJANZ/XELJANZ XR, talk to your healthcare provider about how you can join this pregnancy registry or you may contact the registry at 1-877-311-8972 to enroll.
- plan to breastfeed or are breastfeeding. You and your healthcare provider should decide if you will take XELJANZ/XELJANZ XR or breastfeed. You should not do both. After you stop your treatment with XELJANZ/XELJANZ XR do not start breastfeeding again until:
 - 18 hours after your last dose of XELJANZ or
 - 36 hours after your last dose of XELJANZ XR

Tell your healthcare provider about all the medicines you take, including prescription and over-the-counter medicines, vitamins, and herbal supplements. XELJANZ/XELJANZ XR and other medicines may affect each other causing side effects.

Especially tell your healthcare provider if you take:

- any other medicines to treat your rheumatoid arthritis, psoriatic arthritis, or ulcerative colitis. You should not take tocilizumab (Actemra[®]), etanercept (Enbrel[®]), adalimumab (Humira[®]), infliximab (Remicade[®]), rituximab (Rituxan[®]), abatacept (Orencia[®]), anakinra (Kineret[®]), certolizumab (Cimzia[®]), golimumab (Simponi[®]), ustekinumab (Stelara[®]), secukinumab (Cosentyx[®]), vedolizumab (Entyvio[®]), azathioprine, cyclosporine, or other immunosuppressive drugs while you are taking XELJANZ or XELJANZ XR. Taking XELJANZ or XELJANZ XR with these medicines may increase your risk of infection.
- medicines that affect the way certain liver enzymes work. Ask your healthcare provider if you are not sure if your medicine is one of these.

Know the medicines you take. Keep a list of them to show your healthcare provider and pharmacist when you get a new medicine.

How should I take XELJANZ/XELJANZ XR? Take XELJANZ/XELJANZ XR exactly as your healthcare provider tells you to take it.

- Take XELJANZ 2 times a day with or without food.
- Take XELJANZ XR 1 time a day with or without food.
- Swallow XELJANZ XR tablets whole and intact. Do not crush, split, or chew.
- When you take XELJANZ XR, you may see something in your stool that looks like a tablet. This is the empty shell from the tablet after the medicine has been absorbed by your body.

- If you take too much XELJANZ/XELJANZ XR, call your healthcare provider or go to the nearest hospital emergency room right away.
- For the treatment of psoriatic arthritis, take XELJANZ/XELJANZ XR in combination with methotrexate, sulfasalazine or leflunomide as instructed by your healthcare provider.

What are possible side effects of XELJANZ/XELJANZ XR?

XELJANZ/XELJANZ XR may cause serious side effects, including:

- See “What is the most important information I should know about XELJANZ/XELJANZ XR?”
- **Hepatitis B or C activation infection** in people who carry the virus in their blood. If you are a carrier of the hepatitis B or C virus (viruses that affect the liver), the virus may become active while you use XELJANZ/XELJANZ XR. Your healthcare provider may do blood tests before you start treatment with XELJANZ/XELJANZ XR and while you are using XELJANZ/XELJANZ XR. Tell your healthcare provider if you have any of the following symptoms of a possible hepatitis B or C infection:
 - feel very tired
 - little or no appetite
 - clay-colored bowel movements
 - chills
 - muscle aches
 - skin rash
 - skin or eyes look yellow
 - vomiting
 - fevers
 - stomach discomfort
 - dark urine

Common side effects of XELJANZ/XELJANZ XR in rheumatoid arthritis patients and psoriatic arthritis patients include:

- upper respiratory tract infections (common cold, sinus infections)
- headache
- diarrhea
- nasal congestion, sore throat, and runny nose (nasopharyngitis)
- high blood pressure (hypertension)

Common side effects of XELJANZ/XELJANZ XR in ulcerative colitis patients include:

- nasal congestion, sore throat, and runny nose (nasopharyngitis)
- increased cholesterol levels
- headache
- upper respiratory tract infections (common cold, sinus infections)
- increased muscle enzyme levels
- rash
- diarrhea
- shingles (herpes zoster)

Tell your healthcare provider if you have any side effect that bothers you or that does not go away. These are not all the possible side effects of XELJANZ/XELJANZ XR. For more information, ask your healthcare provider or pharmacist.

Call your doctor for medical advice about side effects. You may report side effects to FDA at 1-800-FDA-1088.

You may also report side effects to Pfizer at 1-800-438-1985.

How should I store XELJANZ/XELJANZ XR?

- Store XELJANZ/XELJANZ XR at room temperature between 68°F to 77°F (20°C to 25°C).
- Safely throw away medicine that is out of date or no longer needed.

Keep XELJANZ/XELJANZ XR and all medicines out of the reach of children.

General information about the safe and effective use of XELJANZ/XELJANZ XR.

Medicines are sometimes prescribed for purposes other than those listed in a Medication Guide. Do not use XELJANZ/XELJANZ XR for a condition for which it was not prescribed. Do not give XELJANZ/XELJANZ XR to other people, even if they have the same symptoms you have. It may harm them.

This Medication Guide summarizes the most important information about XELJANZ/XELJANZ XR. If you would like more information, talk to your healthcare provider. You can ask your pharmacist or healthcare provider for information about XELJANZ/XELJANZ XR that is written for health professionals.

What are the ingredients in XELJANZ 5 mg?

Active ingredient: tofacitinib citrate

Inactive ingredients: croscarmellose sodium, HPMC 2910/Hypromellose 6cP, lactose monohydrate, macrogol/PEG3350, magnesium stearate, microcrystalline cellulose, titanium dioxide, and triacetin.

What are the ingredients in XELJANZ 10 mg?

Active ingredient: tofacitinib citrate

Inactive ingredients: croscarmellose sodium, FD&C Blue #1/Brilliant Blue FCF Aluminum Lake, FD&C Blue #2/Indigo Carmine Aluminum Lake, HPMC 2910/Hypromellose 6cP, lactose monohydrate, macrogol/PEG3350, magnesium stearate, microcrystalline cellulose, titanium dioxide, and triacetin.

What are the ingredients in XELJANZ XR 11 mg?

Active ingredient: tofacitinib citrate

Inactive ingredients: cellulose acetate, copovidone, hydroxyethyl cellulose, hydroxypropyl cellulose, HPMC 2910/Hypromellose, magnesium stearate, red iron oxide, sorbitol, titanium dioxide, and triacetin. Printing ink contains ammonium hydroxide, ferrosiferrous oxide/black iron, propylene glycol, and shellac glaze.

What are the ingredients in XELJANZ XR 22 mg?

Active ingredient: tofacitinib citrate

Inactive ingredients: cellulose acetate, copovidone, FD&C Blue #2 Aluminum Lake, hydroxyethyl cellulose, hydroxypropyl cellulose, HPMC 2910/Hypromellose, magnesium stearate, red iron oxide, sorbitol, titanium dioxide, triacetin, and yellow iron oxide. Printing ink contains ammonium hydroxide, ferrosiferrous oxide/black iron oxide, propylene glycol, and shellac glaze.



LAB-0535-10.0

This Medication Guide has been approved by the U.S. Food and Drug Administration.

Revised: Dec 2019

HIGHLIGHTS OF PRESCRIBING INFORMATION

These highlights do not include all the information needed to use XIFAXAN safely and effectively. See full prescribing information for XIFAXAN.

XIFAXAN® (rifaximin) Tablets
Initial U.S. Approval: 2004

To reduce the development of drug-resistant bacteria and maintain the effectiveness of XIFAXAN and other antibacterial drugs, XIFAXAN should be used only to treat or prevent infections that are proven or strongly suspected to be caused by bacteria.

RECENT MAJOR CHANGES

Indications and Usage, Hepatic Encephalopathy (1.3) xx/xxxx
Dosage and Administration, Hepatic Encephalopathy (2.2) xx/xxxx

INDICATIONS AND USAGE

XIFAXAN is a rifamycin antibacterial indicated for:

- The treatment of patients (≥ 12 years of age) with travelers' diarrhea caused by noninvasive strains of *Escherichia coli* (1.1)
- Reduction in risk of overt hepatic encephalopathy (HE) recurrence in patients ≥ 18 years of age (1.2)

Limitations of Use

- TD: Do not use in patients with diarrhea complicated by fever or blood in the stool or diarrhea due to pathogens other than *Escherichia coli* (1.1)

DOSAGE AND ADMINISTRATION

- Travelers' diarrhea: one 200 mg tablet taken orally three times a day for 3 days, with or without food (2.1)
- Hepatic encephalopathy: One 550 mg tablet taken orally two times a day, with or without food (2.2)

DOSAGE FORMS AND STRENGTHS

- 200 mg and 550 mg tablets (3)

CONTRAINDICATIONS

History of hypersensitivity to rifaximin, rifamycin antimicrobial agents, or any of the components of XIFAXAN (4.1)

WARNINGS AND PRECAUTIONS

- Travelers' Diarrhea Not Caused by *E. coli*: XIFAXAN was not effective in diarrhea complicated by fever and/or blood in the stool or diarrhea due to pathogens other than *E. coli*. If diarrhea symptoms get worse or persist for more than 24-48 hours, discontinue XIFAXAN and consider alternative antibiotics (5.1)
- *Clostridium difficile*-Associated Diarrhea: Evaluate if diarrhea occurs after therapy or does not improve or worsens during therapy (5.2)
- Hepatic Impairment: Use with caution in patients with severe (Child-Pugh C) hepatic impairment (5.4, 8.7)

ADVERSE REACTIONS

- Most common adverse reactions in travelers' diarrhea (≥ 5%): Flatulence, headache, abdominal pain, rectal tenesmus, defecation urgency and nausea (6.1)
- Most common adverse reactions in HE (≥ 10%): Peripheral edema, nausea, dizziness, fatigue, ascites, flatulence, and headache (6.1)

To report suspected adverse reactions, contact Salix Pharmaceuticals at 1-866-669-7597 and www.Salix.com or FDA at 1-800-FDA-1088 or www.fda.gov/medwatch

USE IN SPECIFIC POPULATIONS

- Pregnancy: Based on animal data, may cause fetal harm (8.1)
- Nursing Mothers: Discontinue nursing or drug, taking into account the importance of the drug to the mother (8.3)

See 17 for PATIENT COUNSELING INFORMATION

Revised: xxx/2010

1	FULL PRESCRIBING INFORMATION: CONTENTS*
2	
3	1 INDICATIONS AND USAGE
4	1.1 Travelers' Diarrhea
5	1.2 Hepatic Encephalopathy
6	2 DOSAGE AND ADMINISTRATION
7	2.1 Dosage for Travelers' Diarrhea
8	2.2 Dosage for Hepatic Encephalopathy
9	3 DOSAGE FORMS AND STRENGTHS
10	4 CONTRAINDICATIONS
11	4.1 Hypersensitivity
12	5 WARNINGS AND PRECAUTIONS
13	5.1 Travelers' Diarrhea Not Caused by <i>Escherichia coli</i>
14	5.2 <i>Clostridium difficile</i> -Associated Diarrhea
15	5.3 Development of Drug Resistant Bacteria
16	5.4 Severe (Child-Pugh C) Hepatic Impairment
17	6 ADVERSE REACTIONS
18	6.1 Clinical Studies Experience
19	6.2 Postmarketing Experience
20	7 DRUG INTERACTIONS
21	8 USE IN SPECIFIC POPULATIONS
22	8.1 Pregnancy
23	8.3 Nursing Mothers
24	8.4 Pediatric Use
25	8.5 Geriatric Use
26	8.6 Renal Impairment
27	8.7 Hepatic Impairment
28	10 OVERDOSAGE
29	11 DESCRIPTION
30	12 CLINICAL PHARMACOLOGY
31	12.1 Mechanism of Action
32	12.3 Pharmacokinetics
33	12.4 Microbiology
34	13 NONCLINICAL TOXICOLOGY
35	13.1 Carcinogenesis, Mutagenesis, Impairment of Fertility
36	13.2 Animal Toxicology and/or Pharmacology
37	14 CLINICAL STUDIES
38	14.1 Travelers' Diarrhea
39	14.2 Hepatic Encephalopathy

40	15 REFERENCES
41	16 HOW SUPPLIED/STORAGE AND HANDLING
42	17 PATIENT COUNSELING INFORMATION
43	17.1 Persistent Diarrhea
44	17.2 <i>Clostridium difficile</i> -Associated Diarrhea
45	17.3 Administration with Food
46	17.4 Antibacterial Resistance
47	17.5 Severe Hepatic Impairment
48	
49	
50	
51	

52 *Sections or subsections omitted from the full prescribing information are not listed

53
54
55
56
57
58
59
60
61
62
63
64
65
66
67
68
69
70
71

72 **FULL PRESCRIBING INFORMATION**

73
74

75 **1 INDICATIONS AND USAGE**

76
77
78
79
80
81
82
83

To reduce the development of drug-resistant bacteria and maintain the effectiveness of XIFAXAN and other antibacterial drugs, XIFAXAN when used to treat infection should be used only to treat or prevent infections that are proven or strongly suspected to be caused by susceptible bacteria. When culture and susceptibility information are available, they should be considered in selecting or modifying antibacterial therapy. In the absence of such data, local epidemiology and susceptibility patterns may contribute to the empiric selection of therapy.

84

1.1 Travelers' Diarrhea

85
86
87
88
89

XIFAXAN 200 mg is indicated for the treatment of patients (≥ 12 years of age) with travelers' diarrhea caused by noninvasive strains of *Escherichia coli* [see *Warnings and Precautions* (5), *Clinical Pharmacology* (12.4) and *Clinical Studies* (14.1)].

90

Limitations of Use

91
92

XIFAXAN should not be used in patients with diarrhea complicated by fever or blood in the stool or diarrhea due to pathogens other than *Escherichia coli*.

93

1.2 Hepatic Encephalopathy

94
95
96

XIFAXAN 550 mg is indicated for reduction in risk of overt hepatic encephalopathy (HE) recurrence in patients ≥ 18 years of age.

97 In the trials of XIFAXAN for HE, 91% of the patients were using lactulose
98 concomitantly. Differences in the treatment effect of those patients not using
99 lactulose concomitantly could not be assessed.

100 XIFAXAN has not been studied in patients with MELD (Model for End-
101 Stage Liver Disease) scores > 25, and only 8.6% of patients in the controlled trial
102 had MELD scores over 19. There is increased systemic exposure in patients with
103 more severe hepatic dysfunction [see *Warnings and Precautions (5.4), Use in*
104 *Specific Populations (8.7), Clinical Pharmacology (12.3)*].

105
106

107 **2 DOSAGE AND ADMINISTRATION**

109 **2.1 Dosage for Travelers' Diarrhea:**

110 The recommended dose of XIFAXAN is one 200 mg tablet taken orally three
111 times a day for 3 days. XIFAXAN can be administered orally, with or without
112 food [see *Clinical Pharmacology (12.3)*].

113
114

115 **2.2 Dosage for Hepatic Encephalopathy**

116 The recommended dose of XIFAXAN is one 550 mg tablet taken orally two
117 times a day, with or without food [see *Clinical Pharmacology (12.3)*].

118
119

120 **3 DOSAGE FORMS AND STRENGTHS**

121 XIFAXAN is pink-colored biconvex tablets and is available in the following
122 strengths:

- 123 • 200 mg – a round tablet debossed with “Sx” on one side.
- 124 • 550 mg – an oval tablet debossed with “rfx” on one side.

125
126

126 **4 CONTRAINDICATIONS**

127 **4.1 Hypersensitivity**

128 XIFAXAN is contraindicated in patients with a hypersensitivity to rifaximin,
129 any of the rifamycin antimicrobial agents, or any of the components in
130 XIFAXAN. Hypersensitivity reactions have included exfoliative dermatitis,
131 angioneurotic edema, and anaphylaxis [see *Adverse Reactions (6.2)*].

132
133

133 **5 WARNINGS AND PRECAUTIONS**

134 **5.1 Travelers' Diarrhea Not Caused by *Escherichia coli***

135 XIFAXAN was not found to be effective in patients with diarrhea complicated by fever
136 and/or blood in the stool or diarrhea due to pathogens other than *Escherichia coli*.

137 Discontinue XIFAXAN if diarrhea symptoms get worse or persist more than 24-48 hours
138 and alternative antibiotic therapy should be considered.

139 XIFAXAN is not effective in cases of travelers' diarrhea due to *Campylobacter jejuni*. The
140 effectiveness of XIFAXAN in travelers' diarrhea caused by *Shigella* spp. and *Salmonella* spp.
141 has not been proven. XIFAXAN should not be used in patients where *Campylobacter jejuni*,
142 *Shigella* spp., or *Salmonella* spp. may be suspected as causative pathogens.

143
144

144 **5.2 *Clostridium difficile*-Associated Diarrhea**

145

146 *Clostridium difficile*-associated diarrhea (CDAD) has been reported with use of nearly all
147 antibacterial agents, including XIFAXAN, and may range in severity from mild diarrhea to
148 fatal colitis. Treatment with antibacterial agents alters the normal flora of the colon which may
149 lead to overgrowth of *C. difficile*.

150 *C. difficile* produces toxins A and B which contribute to the development of CDAD.
151 Hypertoxin producing strains of *C. difficile* cause increased morbidity and mortality, as these
152 infections can be refractory to antimicrobial therapy and may require colectomy. CDAD must
153 be considered in all patients who present with diarrhea following antibiotic use. Careful
154 medical history is necessary since CDAD has been reported to occur over two months after the
155 administration of antibacterial agents.

156 If CDAD is suspected or confirmed, ongoing antibiotic use not directed against *C. difficile*
157 may need to be discontinued. Appropriate fluid and electrolyte management, protein
158 supplementation, antibiotic treatment of *C. difficile*, and surgical evaluation should be
159 instituted as clinically indicated.

160

161 **5.3 Development of Drug Resistant Bacteria**

162 Prescribing XIFAXAN for travelers' diarrhea in the absence of a proven or strongly
163 suspected bacterial infection or a prophylactic indication is unlikely to provide benefit to the
164 patient and increases the risk of the development of drug-resistant bacteria.

165

166 **5.4 Severe (Child-Pugh C) Hepatic Impairment**

167 There is increased systemic exposure in patients with severe hepatic impairment. Animal
168 toxicity studies did not achieve systemic exposures that were seen in patients with severe
169 hepatic impairment. The clinical trials were limited to patients with MELD scores <25.
170 Therefore, caution should be exercised when administering XIFAXAN to patients with severe
171 hepatic impairment (Child-Pugh C) [see *Use in Specific Populations (8.7), Nonclinical*
172 *Toxicology (13.2) and Clinical Studies (14.2)*].

173

174 **6 ADVERSE REACTIONS**

175 **6.1 Clinical Studies Experience**

176 Because clinical trials are conducted under widely varying conditions, adverse reaction
177 rates observed in the clinical trials of a drug cannot be directly compared to rates in the clinical
178 trials of another drug and may not reflect the rates observed in practice.

179

180 Travelers' Diarrhea

181 The safety of XIFAXAN 200 mg taken three times a day was evaluated in patients with
182 travelers' diarrhea consisting of 320 patients in two placebo-controlled clinical trials with 95%
183 of patients receiving three or four days of treatment with XIFAXAN. The population studied
184 had a mean age of 31.3 (18-79) years of which approximately 3% were \geq 65 years old, 53%
185 were male and 84% were White, 11% were Hispanic.

186 Discontinuations due to adverse reactions occurred in 0.4% of patients. The adverse
187 reactions leading to discontinuation were taste loss, dysentery, weight decrease, anorexia,
188 nausea and nasal passage irrigation.

189 All adverse reactions for XIFAXAN 200 mg three times daily that occurred at a frequency
190 \geq 2% in the two placebo-controlled trials combined are provided in Table 1. (These include
191 adverse reactions that may be attributable to the underlying disease.)

192

Table 1. All Adverse Reactions With an Incidence $\geq 2\%$ Among Patients Receiving XIFAXAN Tablets, 200 mg Three Times Daily, in Placebo-Controlled Studies

MedDRA Preferred Term	Number (%) of Patients	
	XIFAXAN Tablets, 600 mg/day N = 320	Placebo N = 228
Flatulence	36 (11%)	45 (20%)
Headache	31 (10%)	21 (9%)
Abdominal Pain NOS*	23 (7%)	23 (10%)
Rectal Tenesmus	23 (7%)	20 (9%)
Defecation Urgency	19 (6%)	21 (9%)
Nausea	17 (5%)	19 (8%)
Constipation	12 (4%)	8 (4%)
Pyrexia	10 (3%)	10 (4%)
Vomiting NOS	7 (2%)	4 (2%)

*NOS: Not otherwise specified

The following adverse reactions, presented by body system, have also been reported in $<2\%$ of patients taking XIFAXAN in the two placebo-controlled clinical trials where the 200 mg tablet was taken three times a day for travelers' diarrhea. The following includes adverse reactions regardless of causal relationship to drug exposure.

- Blood and Lymphatic System Disorders:* Lymphocytosis, monocytosis, neutropenia
- Ear and Labyrinth Disorders:* Ear pain, motion sickness, tinnitus
- Gastrointestinal Disorders:* Abdominal distension, diarrhea NOS, dry throat, fecal abnormality NOS, gingival disorder NOS, inguinal hernia NOS, dry lips, stomach discomfort
- General Disorders and Administration Site Conditions:* Chest pain, fatigue, malaise, pain NOS, weakness
- Infections and Infestations:* Dysentery NOS, respiratory tract infection NOS, upper respiratory tract infection NOS
- Injury and Poisoning:* Sunburn
- Investigations:* Aspartate aminotransferase increased, blood in stool, blood in urine, weight decreased
- Metabolic and Nutritional Disorders:* Anorexia, dehydration
- Musculoskeletal, Connective Tissue, and Bone Disorders:* Arthralgia, muscle spasms, myalgia, neck pain
- Nervous System Disorders:* Abnormal dreams, dizziness, migraine NOS, syncope, loss of taste
- Psychiatric Disorders:* Insomnia
- Renal and Urinary Disorders:* Choloria, dysuria, hematuria, polyuria, proteinuria, urinary frequency
- Respiratory, Thoracic, and Mediastinal Disorders:* Dyspnea NOS, nasal passage irritation, nasopharyngitis, pharyngitis, pharyngolaryngeal pain, rhinitis NOS, rhinorrhea
- Skin and Subcutaneous Tissue Disorders:* Clamminess, rash NOS, sweating increased
- Vascular Disorders:* Hot flashes NOS

Hepatic Encephalopathy

The data described below reflect exposure to XIFAXAN 550 mg in 348 patients, including 265 exposed for 6 months and 202 exposed for more than a year (mean exposure was 364 days). The safety of XIFAXAN 550 mg taken two times a day for reducing the risk of overt hepatic encephalopathy recurrence in adult patients was evaluated in a 6-month placebo-

229 controlled clinical trial (n = 140) and in a long term follow-up study (n = 280). The population
 230 studied had a mean age of 56.26 (range: 21-82) years; approximately 20% of the patients were
 231 \geq 65 years old, 61% were male, 86% were White, and 4% were Black. Ninety-one percent of
 232 patients in the trial were taking lactulose concomitantly. All adverse reactions that occurred at
 233 an incidence \geq 5% and at a higher incidence in XIFAXAN 550 mg-treated subjects than in the
 234 placebo group in the 6-month trial are provided in Table 2. (These include adverse events that
 235 may be attributable to the underlying disease).
 236

237 **Table 2: Adverse Reactions Occurring in \geq 5% of Patients Receiving XIFAXAN and**
 238 **at a Higher Incidence Than Placebo**

MedDRA Preferred Term	Number (%) of Patients	
	XIFAXAN Tablets 550 mg TWICE DAILY N = 140	Placebo N = 159
Edema peripheral	21 (15%)	13 (8%)
Nausea	20 (14%)	21 (13%)
Dizziness	18 (13%)	13 (8%)
Fatigue	17 (12%)	18 (11%)
Ascites	16 (11%)	15 (9%)
Muscle spasms	13 (9%)	11 (7%)
Pruritus	13 (9%)	10 (6%)
Abdominal pain	12 (9%)	13 (8%)
Abdominal distension	11 (8%)	12 (8%)
Anemia	11 (8%)	6 (4%)
Cough	10 (7%)	11 (7%)
Depression	10 (7%)	8 (5%)
Insomnia	10 (7%)	11 (7%)
Nasopharyngitis	10 (7%)	10 (6%)
Abdominal pain upper	9 (6%)	8 (5%)
Arthralgia	9 (6%)	4 (5%)
Back pain	9 (6%)	10 (6%)
Constipation	9 (6%)	10 (6%)
Dyspnea	9 (6%)	7 (4%)
Pyrexia	9 (6%)	5 (3%)
Rash	7 (5%)	6 (4%)

239
 240 The following adverse reactions, presented by body system, have also been reported in the
 241 placebo-controlled clinical trial in greater than 2% but less than 5% of patients taking
 242 XIFAXAN 550 mg taken orally two times a day for hepatic encephalopathy. The following
 243 includes adverse events occurring at a greater incidence than placebo, regardless of causal
 244 relationship to drug exposure.

245
 246 *Ear and Labyrinth Disorders:* Vertigo

247 *Gastrointestinal Disorders:* Abdominal pain lower, abdominal tenderness, dry mouth,
 248 esophageal variceal bleed, stomach discomfort

249 *General Disorders and Administration Site Conditions:* Chest pain, generalized edema,
 250 influenza like illness, pain NOS

251 *Infections and Infestations:* Cellulitis, pneumonia, rhinitis, upper respiratory tract infection
 252 NOS

253 *Injury, Poisoning and Procedural Complications:* Contusion, fall, procedural pain

254 *Investigations:* Weight increased

255 *Metabolic and Nutritional Disorders:* Anorexia, dehydration, hyperglycemia,
256 hyperkalemia, hypoglycemia, hyponatremia
257 *Musculoskeletal, Connective Tissue, and Bone Disorders:* Myalgia, pain in extremity
258 *Nervous System Disorders:* Amnesia, disturbance in attention, hypoesthesia, memory
259 impairment, tremor
260 *Psychiatric Disorders:* Confusional state
261 *Respiratory, Thoracic, and Mediastinal Disorders:* Epistaxis
262 *Vascular Disorders:* Hypotension
263
264

265 **6.2 Postmarketing Experience**

266 The following adverse reactions have been identified during post approval use of
267 XIFAXAN. Because these reactions are reported voluntarily from a population of unknown
268 size, estimates of frequency cannot be made. These reactions have been chosen for inclusion
269 due to either their seriousness, frequency of reporting or causal connection to XIFAXAN.

270 *Infections and Infestations*

271 Cases of *C. difficile*-associated colitis have been reported [*see Warnings and Precautions*
272 (5.2)].

273 *General*

274 Hypersensitivity reactions, including exfoliative dermatitis, rash, angioneurotic edema
275 (swelling of face and tongue and difficulty swallowing), urticaria, flushing, pruritus and
276 anaphylaxis have been reported. These events occurred as early as within 15 minutes of drug
277 administration.

278

279 **7 DRUG INTERACTIONS**

280

281 *In vitro* studies have shown that rifaximin did not inhibit cytochrome P450 isoenzymes
282 1A2, 2A6, 2B6, 2C9, 2C19, 2D6, 2E1 and CYP3A4 at concentrations ranging from 2 to 200
283 ng/mL [*see Clinical Pharmacology (12.3)*]. Rifaximin is not expected to inhibit these enzymes
284 in clinical use.

285

286 An *in vitro* study has suggested that rifaximin induces CYP3A4 [*see Clinical*
287 *Pharmacology (12.3)*]. However, in patients with normal liver function, rifaximin at the
288 recommended dosing regimen is not expected to induce CYP3A4. It is unknown whether
289 rifaximin can have a significant effect on the pharmacokinetics of concomitant CYP3A4
290 substrates in patients with reduced liver function who have elevated rifaximin concentrations.

291

292 An *in vitro* study suggested that rifaximin is a substrate of P-glycoprotein. It is unknown
293 whether concomitant drugs that inhibit P-glycoprotein can increase the systemic exposure of
294 rifaximin [*see Clinical Pharmacology (12.3)*].

295

296

297

298 **8 USE IN SPECIFIC POPULATIONS**

299

300 **8.1 Pregnancy**

301 *Pregnancy Category C*

302 There are no adequate and well controlled studies in pregnant women. XIFAXAN
303 should be used during pregnancy only if the potential benefit outweighs the potential risk
304 to the fetus.

305 Rifaximin was teratogenic in rats at doses of 150 to 300 mg/kg (approximately 2.5 to
306 5 times the clinical dose for travelers' diarrhea [600 mg/day], and approximately 1.3 to
307 2.6 times the clinical dose for hepatic encephalopathy [1100 mg/day], adjusted for body
308 surface area). Rifaximin was teratogenic in rabbits at doses of 62.5 to 1000 mg/kg
309 (approximately 2 to 33 times the clinical dose for travelers' diarrhea [600 mg/day], and
310 approximately 1.1 to 18 times the clinical dose for hepatic encephalopathy [1100
311 mg/day], adjusted for body surface area). These effects include cleft palate, agnatha, jaw
312 shortening, hemorrhage, eye partially open, small eyes, brachygnathia, incomplete
313 ossification, and increased thoracolumbar vertebrae.

314

315

316 **8.3 Nursing Mothers**

317 It is not known whether rifaximin is excreted in human milk. Because many drugs
318 are excreted in human milk and because of the potential for adverse reactions in nursing
319 infants from XIFAXAN, a decision should be made whether to discontinue nursing or to
320 discontinue the drug, taking into account the importance of the drug to the mother.

321

322 **8.4 Pediatric Use**

323 The safety and effectiveness of XIFAXAN 200 mg in pediatric patients with
324 travelers' diarrhea less than 12 years of age have not been established.

325 The safety and effectiveness of XIFAXAN 550 mg for HE have not been established
326 in patients < 18 years of age.

327

328 **8.5 Geriatric Use**

329 Clinical studies with rifaximin 200 mg for travelers' diarrhea did not include
330 sufficient numbers of patients aged 65 and over to determine whether they respond
331 differently than younger subjects.

332

333 In the controlled trial with XIFAXAN 550 mg for hepatic encephalopathy, 19.4%
334 were 65 and over, while 2.3% were 75 and over. No overall differences in safety or
335 effectiveness were observed between these subjects and younger subjects, and other
336 reported clinical experience has not identified differences in responses between the
337 elderly and younger patients, but greater sensitivity of some older individuals cannot be
338 ruled out.

339

340 **8.6 Renal Impairment**

341 The pharmacokinetics of rifaximin in patients with impaired renal function has
342 not been studied.

343

344 **8.7 Hepatic Impairment**

345 Following administration of XIFAXAN 550 mg twice daily to patients with a history of
346 hepatic encephalopathy, the systemic exposure (i.e., AUC_{τ}) of rifaximin was about 10-, 13-,
347 and 20-fold higher in those patients with mild (Child-Pugh A), moderate (Child-Pugh B) and
348 severe (Child-Pugh C) hepatic impairment, respectively, compared to that in healthy
349 volunteers. No dosage adjustment is recommended because rifaximin is presumably acting
350 locally. Nonetheless, caution should be exercised when XIFAXAN is administered to patients

351 with severe hepatic impairment [see *Warnings and Precautions (5.4), Clinical Pharmacology*
352 *(12.3), Nonclinical Toxicology (13.2), and Clinical Studies (14.2)*].

353

354 **10 OVERDOSAGE**

355 No specific information is available on the treatment of overdosage with XIFAXAN. In
356 clinical studies at doses higher than the recommended dose (> 600 mg/day for travelers'
357 diarrhea or > 1100 mg/day for hepatic encephalopathy), adverse reactions were similar in
358 subjects who received doses higher than the recommended dose and placebo. In the case of
359 overdosage, discontinue XIFAXAN, treat symptomatically, and institute supportive measures
360 as required.

361

362

363 **11 DESCRIPTION**

364 XIFAXAN tablets contain rifaximin, a non-aminoglycoside semi-synthetic, nonsystemic
365 antibiotic derived from rifamycin SV. Rifaximin is a structural analog of rifampin. The
366 chemical name for rifaximin is (2*S*,16*Z*,18*E*,20*S*,21*S*,22*R*,23*R*,24*R*,25*S*,26*S*,27*S*,28*E*)-
367 5,6,21,23,25-pentahydroxy-27-methoxy-2,4,11,16,20,22,24,26-octamethyl-2,7-
368 (epoxypentadeca-[1,11,13]trienimino)benzofuro[4,5-*e*]pyrido[1,2-*a*]-benzimidazole-1,15(2*H*)-
369 dione,25-acetate. The empirical formula is C₄₃H₅₁N₃O₁₁ and its molecular weight is 785.9. The
370 chemical structure is represented below:

371

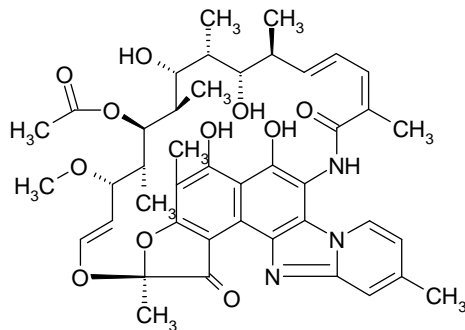

372

373

374

375 XIFAXAN tablets for oral administration are film-coated and contain 200 mg or 550 mg
376 of rifaximin.

377 Inactive ingredients: Each tablet contains colloidal silicon dioxide, disodium edetate,
378 glycerol palmitostearate, hypromellose, microcrystalline cellulose, propylene glycol, red iron
379 oxide, sodium starch glycolate, talc, and titanium dioxide.

380

381 **12 CLINICAL PHARMACOLOGY**

382

383 **12.1 Mechanism of Action**

384 Rifaximin is an antibacterial drug [see *Clinical Pharmacology (12.4)*].

385

386 **12.3 Pharmacokinetics**

387

388 Absorption

389 *Travelers' Diarrhea*

390 Systemic absorption of rifaximin (200 mg three times daily) was evaluated in 13
391 subjects challenged with shigellosis on Days 1 and 3 of a three-day course of treatment.

392 Rifaximin plasma concentrations and exposures were low and variable. There was no
 393 evidence of accumulation of rifaximin following repeated administration for 3 days (9
 394 doses). Peak plasma rifaximin concentrations after 3 and 9 consecutive doses ranged
 395 from 0.81 to 3.4 ng/mL on Day 1 and 0.68 to 2.26 ng/mL on Day 3. Similarly, AUC_{0-last}
 396 estimates were 6.95 ± 5.15 ng•h/mL on Day 1 and 7.83 ± 4.94 ng•h/mL on Day 3.
 397 XIFAXAN is not suitable for treating systemic bacterial infections because of limited
 398 systemic exposure after oral administration [see Warnings and Precautions (5.1)].
 399

400 *Hepatic Encephalopathy*

401 After a single dose and multiple doses of rifaximin 550 mg in healthy subjects, the
 402 mean time to reach peak plasma concentrations was about an hour. The pharmacokinetic
 403 (PK) parameters were highly variable and the accumulation ratio based on AUC was
 404 1.37.
 405

406 The PK of rifaximin in patients with a history of HE was evaluated after
 407 administration of XIFAXAN, 550 mg two times a day. The PK parameters were
 408 associated with a high variability and mean rifaximin exposure (AUC_τ) in patients with a
 409 history of HE (147 ng•h/mL) was approximately 12-fold higher than that observed in
 410 healthy subjects following the same dosing regimen (12.3 ng•h/mL). When PK
 411 parameters were analyzed based on Child-Pugh Class A, B, and C, the mean AUC_τ was
 412 10-, 13-, and 20-fold higher, respectively, compared to that in healthy subjects (Table 3).
 413

414 **Table 3. Mean (± SD) Pharmacokinetic Parameters of Rifaximin at Steady-State in**
 415 **Patients with a History of Hepatic Encephalopathy by Child-Pugh Class¹**

	Healthy Subjects (n = 14)	Child-Pugh Class		
		A (n = 18)	B (n = 7)	C (n = 4)
AUC _{tau} (ng•h/mL)	12.3 ± 4.8	118 ± 67.8	161 ± 101	246 ± 120
C _{max} (ng/mL)	3.4 ± 1.6	19.5 ± 11.4	25.1 ± 12.6	35.5 ± 12.5
T _{max} ² (h)	0.8 (0.5, 4.0)	1 (0.9, 10)	1 (0.97, 1)	1 (0, 2)

416 ¹ Cross-study comparison with PK parameters in healthy subjects

417 ² Median (range)

418

419 *Food Effect in Healthy Subjects*

420 A high-fat meal consumed 30 minutes prior to XIFAXAN dosing in healthy subjects
 421 delayed the mean time to peak plasma concentration from 0.75 to 1.5 hours and increased
 422 the systemic exposure (AUC) of rifaximin by 2-fold (Table 4).
 423

424 **Table 4. Mean (± SD) Pharmacokinetic Parameters After Single-Dose**
 425 **Administration of XIFAXAN Tablets 550 mg in Healthy Subjects**
 426 **Under Fasting and Fed Conditions (N = 12)**

Parameter	Fasting	Fed
C _{max} (ng/mL)	4.1 ± 1.5	4.8 ± 4.3
T _{max} ¹ (h)	0.8 (0.5, 2.1)	1.5 (0.5, 4.1)
Half-Life (h)	1.8 ± 1.4	4.8 ± 1.3
AUC (ng•h/mL)	11.1 ± 4.2	22.5 ± 12

427 ¹Median (range)

428

429 XIFAXAN can be administered with or without food [see Dosage and
 430 Administration (2.1 and 2.2)].

431

432 Distribution

433 Rifaximin is moderately bound to human plasma proteins. *In vivo*, the mean protein
434 binding ratio was 67.5% in healthy subjects and 62% in patients with hepatic impairment
435 when XIFAXAN 550 mg was administered.

436

437 Metabolism and Excretion

438 In a mass balance study, after administration of 400 mg ¹⁴C-rifaximin orally to
439 healthy volunteers, of the 96.94% total recovery, 96.62% of the administered
440 radioactivity was recovered in feces almost exclusively as the unchanged drug and 0.32%
441 was recovered in urine mostly as metabolites with 0.03% as the unchanged drug.
442 Rifaximin accounted for 18% of radioactivity in plasma. This suggests that the absorbed
443 rifaximin undergoes metabolism with minimal renal excretion of the unchanged drug.
444 The enzymes responsible for metabolizing rifaximin are unknown.

445

446 In a separate study, rifaximin was detected in the bile after cholecystectomy in
447 patients with intact gastrointestinal mucosa, suggesting biliary excretion of rifaximin.

448

449 Specific Populations

450

451 Hepatic Impairment

452 The systemic exposure of rifaximin was markedly elevated in patients with hepatic
453 impairment compared to healthy subjects. The mean AUC in patients with Child-Pugh
454 Class C hepatic impairment was 2-fold higher than in patients with Child-Pugh Class A
455 hepatic impairment (see Table 3), [see Warnings and Precautions (5.4) and Use in
456 Specific Populations (8.7)].

457

458 Renal Impairment

459 The pharmacokinetics of rifaximin in patients with impaired renal function has not
460 been studied.

461

462 Drug Interactions

463 *In vitro* drug interaction studies have shown that rifaximin, at concentrations ranging from
464 2 to 200 ng/mL, did not inhibit human hepatic cytochrome P450 isoenzymes 1A2, 2A6, 2B6,
465 2C9, 2C19, 2D6, 2E1, and 3A4.

466 In an *in vitro* study, rifaximin was shown to induce CYP3A4 at the concentration of 0.2
467 μM.

468 An *in vitro* study suggests that rifaximin is a substrate of P-glycoprotein. In the presence
469 of P-glycoprotein inhibitor verapamil, the efflux ratio of rifaximin was reduced greater than
470 50% *in vitro*. The effect of P-glycoprotein inhibition on rifaximin was not evaluated *in vivo*.

471 The inhibitory effect of rifaximin on P-gp transporter was observed in an *in vitro* study.
472 The effect of rifaximin on P-gp transporter was not evaluated *in vivo*.

473

474 Midazolam

475 The effect of rifaximin 200 mg administered orally every 8 hours for 3 days and for 7 days
476 on the pharmacokinetics of a single dose of either midazolam 2 mg intravenous or midazolam
477 6 mg orally was evaluated in healthy subjects. No significant difference was observed in the
478 metrics of systemic exposure or elimination of intravenous or oral midazolam or its major
479 metabolite, 1'-hydroxymidazolam, between midazolam alone or together with rifaximin.

480 Therefore, rifaximin was not shown to significantly affect intestinal or hepatic CYP3A4
481 activity for the 200 mg three times a day dosing regimen.

482

483 After XIFAXAN 550 mg was administered three times a day for 7 days and 14 days to
484 healthy subjects, the mean AUC of single midazolam 2 mg orally was 3.8% and 8.8% lower,
485 respectively, than when midazolam was administered alone. The mean C_{max} of midazolam was
486 also decreased by 4-5% when XIFAXAN was administered for 7-14 days prior to midazolam
487 administration. This degree of interaction is not considered clinically meaningful.

488

489 The effect of rifaximin on CYP3A4 in patients with impaired liver function who have
490 elevated systemic exposure is not known.

491

492 *Oral Contraceptives Containing 0.07 mg Ethinyl Estradiol and 0.5 mg Norgestimate*

493 The oral contraceptive study utilized an open-label, crossover design in 28 healthy female
494 subjects to determine if rifaximin 200 mg orally administered three times a day for 3 days (the
495 dosing regimen for travelers' diarrhea) altered the pharmacokinetics of a single dose of an oral
496 contraceptive containing 0.07 mg ethinyl estradiol and 0.5 mg norgestimate. Results showed
497 that the pharmacokinetics of single doses of ethinyl estradiol and norgestimate were not altered
498 by rifaximin [*see Drug Interactions (7)*].

499

500 Effect of rifaximin on oral contraceptives was not studied for XIFAXAN 550 mg
501 twice a day, the dosing regimen for hepatic encephalopathy.

502

503 **12.4 Microbiology**

504 Mechanism of Action

505 Rifaximin is a non-aminoglycoside semi-synthetic antibacterial derived from
506 rifamycin SV. Rifaximin acts by binding to the beta-subunit of bacterial DNA-dependent
507 RNA polymerase resulting in inhibition of bacterial RNA synthesis.

508

509 *Escherichia coli* has been shown to develop resistance to rifaximin *in vitro*.
510 However, the clinical significance of such an effect has not been studied.

511

512 Rifaximin is a structural analog of rifampin. Organisms with high rifaximin
513 minimum inhibitory concentration (MIC) values also have elevated MIC values against
514 rifampin. Cross-resistance between rifaximin and other classes of antimicrobials has not
515 been studied.

516

517 Rifaximin has been shown to be active against the following pathogen in clinical
518 studies of infectious diarrhea as described in the *Indications and Usage (1)* section:
519 *Escherichia coli* (enterotoxigenic and enteroaggregative strains).

520

521 For HE, rifaximin is thought to have an effect on the gastrointestinal flora.

522

523 Susceptibility Tests

524 *In vitro* susceptibility testing was performed according to the National Committee for
525 Clinical Laboratory Standards (NCCLS) agar dilution method M7-A6 [*see References*
526 (15)]. However, the correlation between susceptibility testing and clinical outcome has
527 not been determined.

528

529

530 13 NONCLINICAL TOXICOLOGY

531

532 13.1 Carcinogenesis, Mutagenesis, Impairment of Fertility

533 Malignant schwannomas in the heart were significantly increased in male Crl:CD®
534 (SD) rats that received rifaximin by oral gavage for two years at 150 to 250 mg/kg/day
535 (doses equivalent to 2.4 to 4 times the recommended dose of 200 mg three times daily for
536 travelers' diarrhea, and equivalent to 1.3 to 2.2 times the recommended dose of 550 mg
537 twice daily for hepatic encephalopathy, based on relative body surface area comparisons).
538 There was no increase in tumors in Tg.rasH2 mice dosed orally with rifaximin for 26
539 weeks at 150 to 2000 mg/kg/day (doses equivalent to 1.2 to 16 times the recommended
540 daily dose for travelers' diarrhea and equivalent to 0.7 to 9 times the recommended daily
541 dose for hepatic encephalopathy, based on relative body surface area comparisons).

542

543 Rifaximin was not genotoxic in the bacterial reverse mutation assay, chromosomal
544 aberration assay, rat bone marrow micronucleus assay, rat hepatocyte unscheduled DNA
545 synthesis assay, or the CHO/HGPRT mutation assay. There was no effect on fertility in
546 male or female rats following the administration of rifaximin at doses up to 300 mg/kg
547 (approximately 5 times the clinical dose of 600 mg/day, and approximately 2.6 times the
548 clinical dose of 1100 mg/day, adjusted for body surface area).

549

550 13.2 Animal Toxicology and/or Pharmacology

551 Oral administration of rifaximin for 3-6 months produced hepatic proliferation of
552 connective tissue in rats (50 mg/kg/day) and fatty degeneration of liver in dogs (100
553 mg/kg/day). However, plasma drug levels were not measured in these studies.
554 Subsequently, rifaximin was studied at doses as high as 300 mg/kg/day in rats for 6
555 months and 1000 mg/kg/day in dogs for 9 months, and no signs of hepatotoxicity were
556 observed. The maximum plasma AUC_{0-8 hr} values from the 6 month rat and 9 month dog
557 toxicity studies (range: 42-127 ng•h/mL) was lower than the maximum plasma AUC_{0-8 hr}
558 values in cirrhotic patients (range: 19-306 ng•h/mL).

559

560

561 14 CLINICAL STUDIES

562

563 14.1 Travelers' Diarrhea

564 The efficacy of XIFAXAN given as 200 mg orally taken three times a day for 3 days
565 was evaluated in 2 randomized, multi-center, double-blind, placebo-controlled studies in
566 adult subjects with travelers' diarrhea. One study was conducted at clinical sites in
567 Mexico, Guatemala, and Kenya (Study 1). The other study was conducted in Mexico,
568 Guatemala, Peru, and India (Study 2). Stool specimens were collected before treatment
569 and 1 to 3 days following the end of treatment to identify enteric pathogens. The
570 predominant pathogen in both studies was *Escherichia coli*.

571

572 The clinical efficacy of XIFAXAN was assessed by the time to return to normal,
573 formed stools and resolution of symptoms. The primary efficacy endpoint was time to
574 last unformed stool (TLUS) which was defined as the time to the last unformed stool
575 passed, after which clinical cure was declared. Table 5 displays the median TLUS and
576 the number of patients who achieved clinical cure for the intent to treat (ITT) population
577 of Study 1. The duration of diarrhea was significantly shorter in patients treated with

578 XIFAXAN than in the placebo group. More patients treated with XIFAXAN was
579 classified as clinical cures than were those in the placebo group.

580
581

Table 5. Clinical Response in Study 1 (ITT population)

	XIFAXAN (n=125)	Placebo (n=129)	Estimate (97.5% CI)	P-Value
Median TLUS (hours)	32.5	58.6	1.78 ^a (1.26, 2.50)	0.0002
Clinical cure, n (%)	99 (79.2)	78 (60.5)	18.7 ^b (5.3, 32.1)	0.001

^a Hazard Ratio

^b Difference in rates

582

583 Microbiological eradication (defined as the absence of a baseline pathogen in culture
584 of stool after 72 hours of therapy) rates for Study 1 are presented in Table 6 for patients
585 with any pathogen at baseline and for the subset of patients with *Escherichia coli* at
586 baseline. *Escherichia coli* was the only pathogen with sufficient numbers to allow
587 comparisons between treatment groups.

588

589 Even though XIFAXAN had microbiologic activity similar to placebo, it
590 demonstrated a clinically significant reduction in duration of diarrhea and a higher
591 clinical cure rate than placebo. Therefore, patients should be managed based on clinical
592 response to therapy rather than microbiologic response.

593

594 **Table 6. Microbiologic Eradication Rates in Study 1**
595 **Subjects with a Baseline Pathogen**

	XIFAXAN	Placebo
Overall	48/70 (68.6)	41/61 (67.2)
<i>E. coli</i>	38/53 (71.7)	40/54 (74.1)

596

597 The results of Study 2 supported the results presented for Study 1. In addition, this
598 study provided evidence that subjects treated with XIFAXAN with fever and/or blood in
599 the stool at baseline had prolonged TLUS. These subjects had lower clinical cure rates
600 than those without fever or blood in the stool at baseline. Many of the patients with fever
601 and/or blood in the stool (dysentery-like diarrheal syndromes) had invasive pathogens,
602 primarily *Campylobacter jejuni*, isolated in the baseline stool.

603

604 Also in this study, the majority of the subjects treated with XIFAXAN who had
605 *Campylobacter jejuni* isolated as a sole pathogen at baseline failed treatment and the
606 resulting clinical cure rate for these patients was 23.5% (4/17). In addition to not being
607 different from placebo, the microbiologic eradication rates for subjects with
608 *Campylobacter jejuni* isolated at baseline were much lower than the eradication rates
609 seen for *Escherichia coli*.

610

611 In an unrelated open-label, pharmacokinetic study of oral XIFAXAN 200 mg taken
612 every 8 hours for 3 days, 15 adult subjects were challenged with *Shigella flexneri* 2a, of
613 whom 13 developed diarrhea or dysentery and were treated with XIFAXAN. Although
614 this open-label challenge trial was not adequate to assess the effectiveness of XIFAXAN
615 in the treatment of shigellosis, the following observations were noted: eight subjects
616 received rescue treatment with ciprofloxacin either because of lack of response to
617 XIFAXAN treatment within 24 hours (2), or because they developed severe dysentery

618 (5), or because of recurrence of *Shigella flexneri* in the stool (1); five of the 13 subjects
619 received ciprofloxacin although they did not have evidence of severe disease or relapse.

620

621 **14.2 Hepatic Encephalopathy**

622 The efficacy of XIFAXAN 550 mg taken orally two times a day was evaluated in a
623 randomized, placebo-controlled, double-blind, multi-center 6-month trial of adult
624 subjects from the U.S., Canada and Russia who were defined as being in remission (Conn
625 score of 0 or 1) from hepatic encephalopathy (HE). Eligible subjects had ≥ 2 episodes of
626 HE associated with chronic liver disease in the previous 6 months.

627

628 A total of 299 subjects were randomized to receive either XIFAXAN (n=140) or
629 placebo (n=159) in this study. Patients had a mean age of 56 years (range, 21-82 years),
630 81% < 65 years of age, 61% were male and 86% White. At baseline, 67% of patients had
631 a Conn score of 0 and 68% had an asterixis grade of 0. Patients had MELD scores of
632 either ≤ 10 (27%) or 11 to 18 (64%) at baseline. No patients were enrolled with a MELD
633 score of > 25. Nine percent of the patients were Child-Pugh Class C. Lactulose was
634 concomitantly used by 91% of the patients in each treatment arm of the study. Per the
635 study protocol, patients were withdrawn from the study after experiencing a breakthrough
636 HE episode. Other reasons for early study discontinuation included: adverse reactions
637 (XIFAXAN 6%; placebo 4%), patient request to withdraw (XIFAXAN 4%; placebo 6%)
638 and other (XIFAXAN 7%; placebo 5%).

639

640 The primary endpoint was the time to first breakthrough overt HE episode. A
641 breakthrough overt HE episode was defined as a marked deterioration in neurological
642 function and an increase of Conn score to Grade ≥ 2 . In patients with a baseline Conn
643 score of 0, a breakthrough overt HE episode was defined as an increase in Conn score of
644 1 and asterixis grade of 1.

645

646 Breakthrough overt HE episodes were experienced by 31 of 140 subjects (22%) in
647 the XIFAXAN group and by 73 of 159 subjects (46%) in the placebo group during the 6-
648 month treatment period. Comparison of Kaplan-Meier estimates of event-free curves
649 showed XIFAXAN significantly reduced the risk of HE breakthrough by 58% during the
650 6-month treatment period. Presented below in Figure 1 is the Kaplan-Meier event-free
651 curve for all subjects (n = 299) in the study.

652
653
654

Figure 1: Kaplan-Meier Event-Free Curves¹ in HE Study (Time to First Breakthrough-HE Episode up to 6 Months of Treatment, Day 170) (ITT Population)

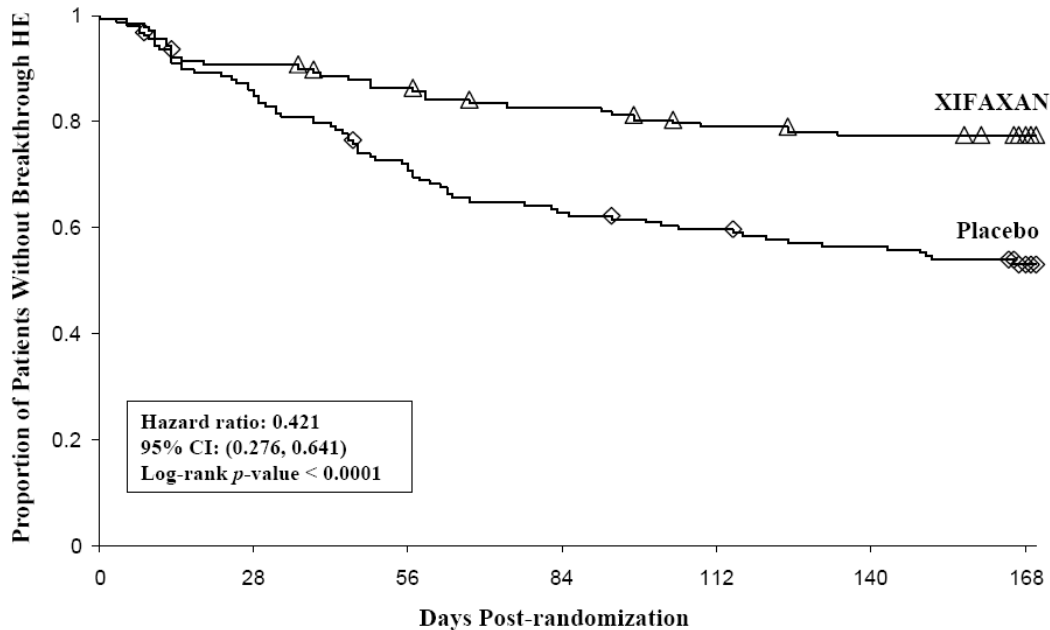

655
656
657
658
659

Note: Open diamonds and open triangles represent censored subjects.
¹ Event-free refers to non-occurrence of breakthrough HE.

660
661
662
663
664
665
666
667

When the results were evaluated by the following demographic and baseline characteristics, the treatment effect of XIFAXAN 550 mg in reducing the risk of breakthrough overt HE recurrence was consistent for: sex, baseline Conn score, duration of current remission and diabetes. The differences in treatment effect could not be assessed in the following subpopulations due to small sample size: non-White (n=42), baseline MELD > 19 (n=26), Child-Pugh C (n=31), and those without concomitant lactulose use (n=26).

668
669
670
671
672
673

HE-related hospitalizations (hospitalizations directly resulting from HE, or hospitalizations complicated by HE) were reported for 19 of 140 subjects (14%) and 36 of 159 subjects (23%) in the XIFAXAN and placebo groups respectively. Comparison of Kaplan-Meier estimates of event-free curves showed XIFAXAN significantly reduced the risk of HE-related hospitalizations by 50% during the 6-month treatment period. Comparison of Kaplan-Meier estimates of event-free curves is shown in Figure 2.

674
675
676

Figure 2: Kaplan-Meier Event-Free Curves¹ in Pivotal HE Study (Time to First HE-Related Hospitalization in HE Study up to 6 Months of Treatment, Day 170) (ITT Population)

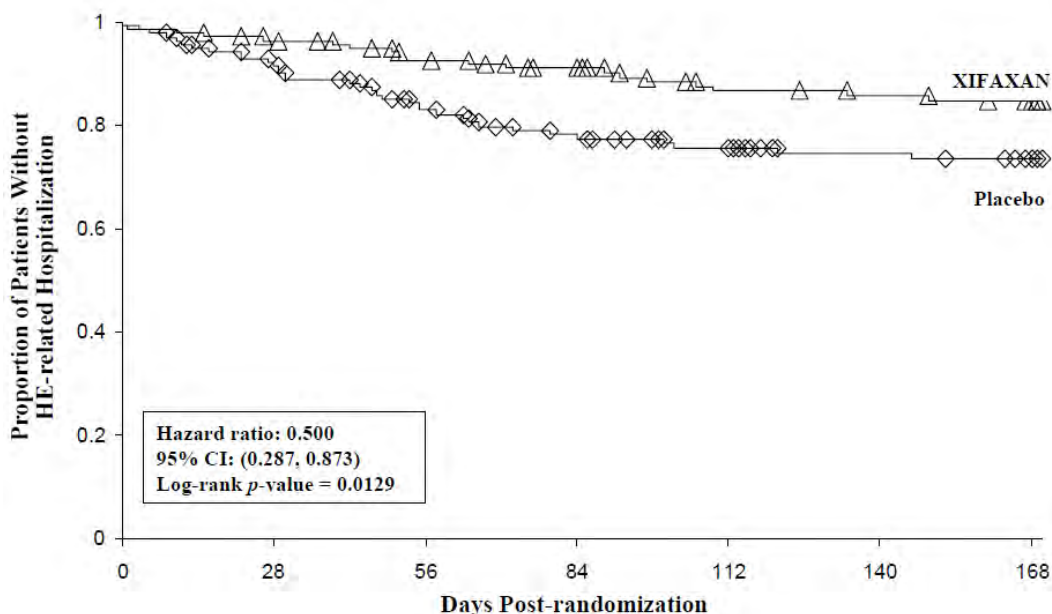

Note: Open diamonds and open triangles represent censored subjects.
¹ Event-free refers to non-occurrence of HE-related hospitalization.

677
678
679
680
681
682
683

15 REFERENCES

Methods for dilution antimicrobial susceptibility tests for bacteria that grow aerobically. National Committee for Clinical Laboratory Standards, Sixth Edition, Wayne PA. *Approved Standard NCCLS Document M7-A6* January 2003; 23 (2).

684
685

16 HOW SUPPLIED/STORAGE AND HANDLING

The 200 mg tablet is a pink-colored, round, biconvex tablet with “Sx” debossed on one side. It is available in the following presentations:

686
687
688

- NDC 65649-301-03, bottles of 30 tablets
- NDC 65649-301-41, bottles of 100 tablets
- NDC 65649-301-05, carton of 100 tablets, Unit Dose

694
695

The 550 mg tablet is a pink-colored, oval, biconvex tablet with “rfx” debossed on one side. It is available in the following presentations:

696
697

- NDC 65649-303-02, bottles of 60 tablets
- NDC 65649-303-03, carton of 60 tablets, Unit Dose

698
699

Storage

Store XIFAXAN Tablets at 20–25°C (68–77°F); excursions permitted to 15–30°C (59–86°F). See USP Controlled Room Temperature.

700
701
702

703
704
705

17 PATIENT COUNSELING INFORMATION

707
708
709
710
711
712
713
714
715
716
717
718
719
720
721
722
723
724
725
726
727
728
729
730
731
732
733
734
735
736
737
738
739
740
741
742
743
744
745
746
747
748
749
750
751
752
753
754
755
756
757

17.1 Persistent Diarrhea

For those patients being treated for travelers' diarrhea, discontinue XIFAXAN if diarrhea persists more than 24-48 hours or worsens. Advise the patient to seek medical care for fever and/or blood in the stool [see *Warnings and Precautions (5.1)*].

17.2 Clostridium difficile-Associated Diarrhea

Clostridium difficile-associated diarrhea (CDAD) has been reported with use of nearly all antibacterial agents, including XIFAXAN, and may range in severity from mild diarrhea to fatal colitis. Treatment with antibiotics alters the normal flora of the colon which may lead to *C. difficile*. Patients can develop watery and bloody stools (with or without stomach cramps and fever) even as late as two or more months after having taken the last dose of the antibiotic. If diarrhea occurs after therapy or does not improve or worsens during therapy, advise patients to contact a physician as soon as possible [see *Warnings and Precautions (5.4)*].

17.3 Administration with Food

Inform patients that XIFAXAN may be taken with or without food.

17.4 Antibacterial Resistance

Counsel patients that antibacterial drugs including XIFAXAN should only be used to treat bacterial infections. They do not treat viral infections (e.g., the common cold). When XIFAXAN is prescribed to treat a bacterial infection, patients should be told that although it is common to feel better early in the course of therapy, the medication should be taken exactly as directed. Skipping doses or not completing the full course of therapy may (1) decrease the effectiveness of the immediate treatment and (2) increase the likelihood that bacteria will develop resistance and will not be treatable by XIFAXAN or other antibacterial drugs in the future.

17.5 Severe Hepatic Impairment

Patients should be informed that in patients with severe hepatic impairment (Child-Pugh C) there is an increase in systemic exposure to XIFAXAN [see *Warnings and Precautions (5.4)*].

Manufactured for Salix Pharmaceuticals, Inc., Morrisville, NC 27560, under license from Alfa Wassermann S.p.A.

XIFAXAN® is a trademark of Salix Pharmaceuticals, Inc., under license from Alfa Wassermann S.p.A.

Copyright © Salix Pharmaceuticals, Inc.

VENART-xxx-0

mmm yyyy

Product protected by US Patent Nos. 7,045,620 and 7,612,199 and other pending applications.

758 Web site: www.Salix.com
759 E-mail: customer.service@salix.com
760 1700 Perimeter Park Drive, Morrisville, NC 27560
761 Tel.866-669-SLXP (7597) Salix Pharmaceuticals, Inc.
762
763 All rights reserved.

PRODUCT MONOGRAPH

PrXtandi®

Enzalutamide capsules

40 mg

Anti-androgen (L02BB04)

Astellas Pharma Canada, Inc.
Markham, ON
L3R 0B8

Date of Initial Approval: May 28, 2013

Date of Revision: June 1, 2020.

®Registered Trademark

Control Number: 233563

Table of Contents

PART I: HEALTH PROFESSIONAL INFORMATION	3
SUMMARY PRODUCT INFORMATION	3
INDICATIONS AND CLINICAL USE.....	3
CONTRAINDICATIONS	3
WARNINGS AND PRECAUTIONS	4
ADVERSE REACTIONS.....	9
DRUG INTERACTIONS	14
DOSAGE AND ADMINISTRATION.....	17
OVERDOSAGE	18
ACTION AND CLINICAL PHARMACOLOGY	18
STORAGE AND STABILITY	23
SPECIAL HANDLING INSTRUCTIONS	23
DOSAGE FORMS, COMPOSITION AND PACKAGING	23
PART II: SCIENTIFIC INFORMATION	24
PHARMACEUTICAL INFORMATION.....	24
CLINICAL TRIALS.....	25
DETAILED PHARMACOLOGY	47
TOXICOLOGY	51
REFERENCES.....	53
PART III: CONSUMER INFORMATION	54

Xtandi®

Enzalutamide capsules

PART I: HEALTH PROFESSIONAL INFORMATION

SUMMARY PRODUCT INFORMATION

Route of Administration	Dosage Form / Strength	Clinically Relevant Nonmedicinal Ingredients
oral	Soft gelatin capsules/ 40 mg	sorbitol <i>For a complete listing, see Dosage Forms, Composition and Packaging section.</i>

INDICATIONS AND CLINICAL USE

Xtandi® (enzalutamide capsules) is indicated for the treatment of patients with metastatic castration-sensitive prostate cancer (mCSPC).

Xtandi® (enzalutamide capsules) is indicated for the treatment of patients with non-metastatic castration-resistant prostate cancer (NM-CRPC).

Xtandi has not been studied in patients with NM-CRPC at low risk of developing metastatic disease (see **Clinical Trials**). The benefit and risk profile in these patients is unknown.

Xtandi® (enzalutamide capsules) is indicated in the setting of medical or surgical castration for the treatment of metastatic castration-resistant prostate cancer (CRPC) in patients who:

- are chemotherapy-naïve with asymptomatic or mildly symptomatic disease after failure of androgen deprivation therapy.
- have received docetaxel therapy.

Geriatrics (≥ 65 years of age): No overall differences in safety and effectiveness were observed between geriatric patients and younger patients in clinical studies (see **WARNINGS AND PRECAUTIONS, Special Populations**).

Pediatrics (< 18 years of age): The safety and efficacy of enzalutamide has not been established for patients less than 18 years of age.

CONTRAINDICATIONS

- Patients who are hypersensitive to enzalutamide or to any ingredient in the formulation or component of the container. For a complete listing, see the **DOSAGE FORMS, COMPOSITION and PACKAGING** section of the product monograph.
- Women who are or may become pregnant, or who are lactating.

WARNINGS AND PRECAUTIONS

Serious Warnings and Precautions

Xtandi (enzalutamide capsules) should only be prescribed by a qualified healthcare professional who is experienced with the treatment of prostate cancer and the use of antineoplastic endocrine therapies.

The following are clinically significant adverse events:

- Seizures (see **Neurologic** section, below),
- Posterior Reversible Encephalopathy Syndrome (see **Neurologic** section, below).

General

Xtandi contains sorbitol (see **DOSAGE FORMS, COMPOSITION AND PACKAGING**). Patients with rare hereditary problems of fructose intolerance should not take Xtandi.

Enzalutamide is a strong inducer of CYP3A4 and a moderate inducer of CYP2C9 and CYP2C19. Medicinal products with a narrow therapeutic range that are substrates of CYP3A4, CYP2C9, and CYP2C19 should be avoided, as co-administration of Xtandi may decrease their exposure. If co-administration cannot be avoided, dose adjustment may be required to maintain therapeutic plasma concentrations (see **DRUG INTERACTIONS**).

Enzalutamide is metabolized by CYP2C8. Co-administration of Xtandi with strong CYP2C8 inhibitors should be avoided. If patients must be co-administered a strong CYP2C8 inhibitor, the dose of Xtandi should be reduced to 80 mg once daily (see **DRUG INTERACTIONS**).

Carcinogenesis and Mutagenesis

Enzalutamide did not show carcinogenic potential (absence of neoplastic findings) in a 6-month study in transgenic rasH2 mice and was devoid of genotoxic potential in the standard panel of *in vitro* and *in vivo* genotoxicity tests. An inactive metabolite (M1) showed genotoxic potential in an *in vitro* mammalian genotoxicity assay, but only at concentrations that caused extensive cytotoxicity (see **TOXICOLOGY, Carcinogenesis and Genotoxicity**).

Cardiovascular

Ischemic Heart Disease: In randomized placebo-controlled phase 3 studies, higher incidences of ischemic heart disease were reported in patients treated with Xtandi (see **ADVERSE REACTIONS, Cardiovascular**). Ischemic events led to death in 0.4% of patients on the Xtandi arm compared to 0.1% on the placebo arm.

Monitor for signs and symptoms of ischemic heart disease. Optimize management of cardiovascular risk factors, such as hypertension, diabetes, or dyslipidemia. Discontinue Xtandi for Grade 3-4 ischemic heart disease.

Patients with clinically significant cardiovascular disease, including recent myocardial infarction (in the past 6 months) or unstable angina (in the past 3 months), New York Heart Association Class (NYHA) III or IV heart failure, except if Left Ventricular Ejection Fraction (LVEF) \geq 45%, bradycardia or uncontrolled hypertension (resting systolic blood pressure $>$ 170 mm Hg and/or diastolic blood pressure $>$ 105 mm Hg) were excluded from the Phase 3 clinical trials (see **CLINICAL TRIALS**). Therefore the safety of Xtandi in these patients has not been established.

QTc Prolongation: In the AFFIRM trial, Xtandi was associated with QTc prolongation of 3.0 to 6.5 msec (placebo-adjusted mean change from baseline) during weeks 5-25 of treatment when administered to metastatic CRPC patients with pre-dose ECG recordings (see **ACTION AND CLINICAL PHARMACOLOGY, Cardiac Electrophysiology**). In the PREVAIL trial, the largest placebo-adjusted mean increase from baseline was 3.4 msec observed at week 37. Consider these observations in clinical decisions to prescribe to patients with a known history of QT prolongation, risk factors for *Torsade de Pointes* (e.g. hypokalemia) or patients who are taking medications known to prolong the QT interval (see **DRUG-DRUG INTERACTIONS, Drugs that Cause QT/QTc Prolongation**).

Hypertension: Xtandi was associated with increases in systolic and diastolic blood pressure and an increased risk of hypertension or worsening of pre-existing hypertension when administered to patients in the Phase 3 clinical trials (see **ACTION AND CLINICAL PHARMACOLOGY, Blood Pressure**). In the Phase 3 trials, the overall incidence of any hypertension-related events was higher in the Xtandi group compared to the placebo group (12.0% vs. 5.0%). Hypertension rarely led to discontinuation or dose modification and, in general, was not associated with major cardiovascular adverse sequelae. However, approximately 75% of patients with this adverse event required initiation of new antihypertensive treatment or increase in dose of prior therapy.

Blood pressure should be measured at baseline and periodically during treatment. Treatment-emergent hypertension should be treated appropriately.

Immune

Hypersensitivity reactions manifested by symptoms including, but not limited to face, tongue, lip and pharyngeal oedema have been observed with enzalutamide (see **ADVERSE REACTIONS, Post-Market Adverse Drug Reactions**). Advise patients who experience any symptoms of hypersensitivity to temporarily discontinue Xtandi and promptly seek medical care. Permanently

discontinue Xtandi for serious hypersensitivity reactions.

Musculoskeletal

Bone Fractures: Xtandi is indicated for use in patients who are maintaining castration status through GnRH analogue therapy or surgical castration. In the Phase 3 clinical trials, a higher incidence of non-pathological bone fractures was reported in the Xtandi group compared to the placebo group (see **ADVERSE REACTIONS**); no assessments of bone mineral density were conducted in these trials (see **CLINICAL TRIALS**).

Falls and Fall-related Injuries: In Phase 3 clinical trials, adverse events of falls were reported in 10.0% Xtandi-treated patients and 3.8% placebo-treated patients. A fall of Grade 3 or greater was reported in 1.1% of patients in the Xtandi-treated group and in 0.4% of patients in the placebo group. Non-pathological fractures associated with falls were reported in 10.2% of patients treated with Xtandi and in 4.4% of patients in the placebo arms. Additionally, in AFFIRM and PREVAIL, fall-related injuries were reported at a greater frequency in the Xtandi arm than the placebo arm (2.4% vs. 1.0%) and included contusion, excoriation, head injury, joint injury, laceration, periorbital haematoma, and skeletal injury. Concomitant neurological symptoms, such as dizziness or syncope, were rarely reported as an adverse event with the falls.

Neurologic

Xtandi is associated with neuropsychiatric adverse events including seizure, memory impairment, and hallucination.

Seizures: In the Phase 3 clinical studies (AFFIRM, PREVAIL, PROSPER and ARCHES) (see **CLINICAL TRIALS**), seizure occurred in 0.9% (7/800), 0.1% (1/871) and 0.3% (3/930), 0.3% (2/572) respectively in patients treated with a daily dose of Xtandi 160 mg. Three patients treated with placebo in the Phase 3 clinical studies experienced a seizure 0.1% (3/2282). Patients experiencing a seizure were discontinued from therapy, and all seizures resolved.

In a single-arm Phase 4 trial to assess incidence of seizure in patients with predisposing factors for seizure, 8 of 366 (2.2%) patients treated with Xtandi (160 mg per day) experienced a seizure. The median duration of treatment was 9.3 months. Use of enzalutamide has been associated with seizure. Xtandi should be used with caution in patients with history of seizures or other predisposing risk factors for seizures. Permanently discontinue Xtandi in patients who develop a seizure during treatment.

Patients with a history of seizure or conditions that may pre-dispose them to seizure, including brain injury with loss of consciousness, transient ischemic attack within the past 12 months, cerebral vascular accident, brain metastases, and brain arteriovenous malformation, were generally excluded from the Phase 3 clinical trials. The AFFIRM trial excluded the use of concomitant medications that may lower the seizure threshold, whereas the PREVAIL and PROSPER trials permitted the use of these medications.

Data from *in vitro* studies show that enzalutamide and its active metabolite (M2) cross the blood brain barrier, bind to, and inhibit the activity of the GABA-gated chloride channel (see **DETAILED PHARMACOLOGY, Animal Pharmacology**).

The dose of Xtandi may be a predictor of seizure in humans, with a greater risk of seizure at daily doses higher than 160 mg. In a dose escalation study involving 140 patients, no seizures were reported at or below daily doses of 240 mg, whereas three seizures were reported, one each at 360, 480, and 600 mg per day.

Mental Impairment Disorders: In the Phase 3 clinical trials, the combined adverse events of amnesia, cognitive disorder, disturbance in attention, memory impairment, and the related term dementia were reported more frequently in Xtandi-treated patients than placebo-treated patients (5.1% vs. 1.7%).

Patients should be advised of the risk of engaging in any activity where mental impairment or sudden loss of consciousness could cause serious harm to themselves or others.

Posterior Reversible Encephalopathy Syndrome: There have been reports of posterior reversible encephalopathy syndrome (PRES) in patients receiving Xtandi. PRES is a rare, reversible neurological disorder which can present with rapidly evolving symptoms including seizure, headache, consciousness impairment (including confusion, somnolence, lethargy, encephalopathy or coma), blindness, and other visual and neurological disturbances, with or without associated hypertension. A diagnosis of PRES requires confirmation by brain imaging, preferably magnetic resonance imaging (MRI). Discontinuation of Xtandi in patients who develop PRES is recommended.

Sexual Function/Reproduction

It is not known whether enzalutamide or its metabolites are present in semen. A condom should be used if the patient engages in sexual activity with a pregnant woman. If the patient is engaged in sex with a woman of child-bearing potential, a condom is recommended along with another effective contraceptive method. These measures are recommended during and for three months after treatment with Xtandi.

Animal studies showed that enzalutamide affected the reproductive organs in rats and dogs (see **TOXICOLOGY**). Considering the pharmacological consequences of androgen receptor inhibition, an effect on male fertility cannot be excluded in humans.

Special Populations

Pregnant Women: Animal studies demonstrated that enzalutamide can cause fetal harm when administered during pregnancy (see **TOXICOLOGY**). Pregnant women who have taken Xtandi should be informed about the potential hazards to embryo-fetal developmental and the risk of pregnancy loss. There are no human data on the use of enzalutamide in pregnancy. Considering the pharmacological consequences of androgen receptor inhibition, maternal use of enzalutamide is expected to produce changes in hormone levels that could affect development of the fetus.

Xtandi is not indicated for use in women. Xtandi is contraindicated in women who are or may become pregnant (see **CONTRAINDICATIONS; TOXICOLOGY**). If this drug is used during pregnancy, or if the patient becomes pregnant while taking this drug, the patient should be apprised of the potential hazard to the fetus.

Nursing Women: Xtandi is not indicated for use in women, and is contraindicated in women who are lactating. It is unknown whether enzalutamide or its metabolites are present in human milk. Enzalutamide and/or its metabolites are secreted in rat milk (see **DETAILED PHARMACOLOGY, Nonclinical Pharmacokinetics**).

Geriatrics (≥ 65 years of age): Of the 3173 patients in Phase 3 trials who received Xtandi, 79% of patients were 65 years and over and 36% were 75 years and over. No overall differences in safety and effectiveness were observed between geriatric patients and younger patients in clinical studies. However, an increased frequency of dose interruption, dose reduction and treatment discontinuation was observed with higher age (≥ 65 years) and greater sensitivity of some older individuals cannot be ruled out.

Pediatrics (< 18 years of age): The safety and efficacy of Xtandi has not been established for patients less than 18 years of age.

Hepatic impairment: Mild, moderate or severe hepatic impairment (Child-Pugh Class A, B or C) had no significant effects on the pharmacokinetics of enzalutamide (see **ACTION AND CLINICAL PHARMACOLOGY, Special Populations and Conditions**). Patients with baseline severe hepatic impairment (Child-Pugh C) were excluded from both the AFFIRM and PREVAIL trials.

Renal impairment: Mild or moderate renal impairment (calculated creatinine clearance (CrCL) values ≥ 30 ml/min) had no significant effects on the pharmacokinetics of enzalutamide (based on population pharmacokinetic analysis). The effect of severe renal impairment on enzalutamide pharmacokinetics has not been studied. Caution is advised in patients with severe renal impairment or end-stage renal disease (see **ACTION AND CLINICAL PHARMACOLOGY, Special Populations and Conditions**).

Monitoring and Laboratory Tests

Monitoring for laboratory or clinical parameters should be conducted as per routine practice. Blood pressure should be measured at baseline and periodically during treatment.

Monitoring of ECG and serum electrolyte levels at baseline and during treatment should be considered for patients at risk for electrolyte abnormality and QTc prolongation.

Enzalutamide is a moderate inducer of CYP2C9. If Xtandi is co-administered with an anticoagulant metabolised by CYP2C9 (e.g. warfarin or acenocoumarol), additional International Normalised Ratio (INR) monitoring should be conducted.

Patients with cardiac history should be assessed for active cardiac disease before starting therapy with Xtandi.

Patients with NM-CRPC should be monitored for disease progression radiographically at the discretion of their treating physician in addition to serum Prostate Specific Antigen (PSA), as 104 out of 219 patients treated with Xtandi in the PROSPER trial reported radiographic progression without PSA progression.

ADVERSE REACTIONS

Adverse Drug Reaction Overview

Adverse reactions in this section were defined as treatment-emergent adverse events if the incidences in the Xtandi group were greater than those in the placebo group.

In the Phase 3 clinical trials, the most common adverse reactions ($\geq 10\%$) seen with Xtandi were arthralgia, back pain, constipation, decreased appetite, dizziness/vertigo, diarrhea, fatigue/asthenia, hot flush, and hypertension. The rate of serious adverse events was 32.3% for Xtandi and 25.7% for placebo. Patients treated with Xtandi also had a higher incidence of Grade 3 or higher serious adverse events (of any causality) than patients treated with placebo (28.2% vs 22.2%). Adverse events as the primary reason that led to treatment discontinuation were reported for 8.4% of Xtandi-treated patients and 6.2% of placebo-treated patients.

Clinical Trial Adverse Drug Reactions

Because clinical trials are conducted under very specific conditions, the adverse reaction rates observed in the clinical trials may not reflect the rates observed in practice and should not be compared to the rates in the clinical trials of another drug. Adverse drug reaction information from clinical trials is useful for identifying drug-related adverse events and for approximating rates.

ARCHES Study: Xtandi versus Placebo in Metastatic Castration-Sensitive Prostate Cancer Patients

The ARCHES trial enrolled 1150 patients with metastatic castration-sensitive prostate cancer (mCSPC). Patients received either Xtandi at a dose of 160 mg once daily (N=572) or placebo (N = 574). The median duration of treatment at the time of analysis was 12.8 months with Xtandi and 11.6 months with placebo.

Table 1 shows adverse reactions reported in ARCHES that occurred at a $\geq 2\%$ higher frequency in the Xtandi arm than the placebo arm.

Table 1: Adverse Reactions^a in ARCHES				
System Organ Class/ MedDRA Preferred Term, MedDRA v21.0	Xtandi N = 572		Placebo N = 574	
	All Grades (%)	Grade 3-4 (%)	All Grades (%)	Grade 3-4 (%)
General disorders and administration site conditions				
Asthenic Conditions ^b	138 (24.1%)	10 (1.7%)	112 (19.5%)	9 (1.6%)
Vascular disorders				
Hot Flush	155 (27.1%)	2 (0.3%)	128 (22.3%)	0
Hypertension	46 (8.0%)	19 (3.3%)	32 (5.6%)	10 (1.7%)
Musculoskeletal and connective tissue disorders				
Musculoskeletal Pain	36 (6.3%)	1 (0.2%)	23 (4.0%)	1 (0.2%)
Injury, Poisoning and Procedural Complications				
Fractures ^c	37 (6.5%)	6 (1.0%)	24 (4.2%)	6 (1.0%)

- a. Adverse Events (AEs) were considered Adverse Reactions if the incidences of AEs in the Xtandi group were greater than those in the placebo group, and if the treatment differences were maintained when the event rates were adjusted per 100 patient-years of exposure.
- b. Includes asthenia and fatigue.
- c. Fracture related preferred terms under high level terms: fractures NEC; fractures and dislocations NEC; limb fractures and dislocations; pelvic fractures and dislocations; skull and brain therapeutic procedures; skull fractures, facial bone fractures and dislocations; spinal fractures and dislocations; thoracic cage fractures and dislocations

PROSPER Study: Non-Metastatic Prostate Cancer that Progressed on Androgen Deprivation Therapy

The PROSPER trial enrolled 1401 patients with non-metastatic CRPC. Patients were randomized 2:1 and received either Xtandi at a dose of 160 mg once daily (N = 930) or placebo (N = 465). The median duration of treatment at the time of analysis was 18.4 months with Xtandi and 11.1 months with placebo. All patients continued on a GnRH analogue or had prior bilateral orchiectomy. Patients were allowed, but not required, to continue or initiate corticosteroids (e.g. prednisone).

Grade 3 or higher adverse reactions were reported among 31.4% of Xtandi-treated patients and 23.4% of placebo-treated patients. Discontinuations with an adverse event as the primary reason were reported for 9.4% of Xtandi-treated patients and 6.0% of placebo-treated patients. Of these, the most common adverse reaction leading to treatment discontinuation was fatigue, which occurred in 1.6% of the Xtandi-treated patients compared to none for the placebo-treated patients.

Overall, 32 patients (3.4%) receiving Xtandi died from adverse events. The reasons for death with ≥ 2 patients included coronary artery disorders (n = 7), sudden death (n = 2), cardiac arrhythmias (n = 2), general physical health deterioration (n = 2), stroke (n = 2), and secondary malignancy (n = 5; one each of acute myeloid leukemia, brain neoplasm, mesothelioma, small cell lung cancer, and malignant neoplasm of unknown primary site). Three patients (0.6%)

receiving placebo died from adverse events of cardiac arrest (n = 1), left ventricular failure (n = 1), and pancreatic carcinoma (n = 1).

Table 2 shows adverse reactions occurring at an incidence of $\geq 2\%$ in patients randomized to Xtandi in the PROSPER study.

Table 2: Adverse Reactions^a Occurring at an Incidence of $\geq 2\%$ in Patients Randomized to Xtandi in the PROSPER Study				
System Organ Class/ MedDRA Preferred Term, MedDRA v16.1	Xtandi N = 930		Placebo N = 465	
	All Grades (%)	Grade 3-4 (%)	All Grades (%)	Grade 3-4 (%)
General disorders and administration site conditions				
Asthenic Conditions ^b	372 (40.0%)	37 (4.0%)	91 (19.6%)	4 (0.9%)
Vascular disorders				
Hot Flush	121 (13.0%)	1 (0.1%)	36 (7.7%)	0 (0.0%)
Hypertension	111 (11.9%)	43 (4.6%)	24 (5.2%)	10 (2.2%)
Nervous system disorders				
Dizziness ^c	108 (11.6%)	5 (0.5%)	24 (5.2%)	0 (0.0%)
Headache	85 (9.1%)	2 (0.2%)	21 (4.5%)	0 (0.0%)
Mental Impairment Disorders ^d	43 (4.6%)	1 (0.1%)	7 (1.5%)	0 (0.0%)
Investigations				
Weight decreased	55 (5.9%)	2 (0.2%)	7 (1.5%)	0 (0.0%)
Injury, poisoning and procedural complications				
Fall	106 (11.4%)	12 (1.3%)	19 (4.1%)	3 (0.6%)
Metabolism and nutrition disorders				
Decreased appetite	89 (9.6%)	2 (0.2%)	18 (3.9%)	1 (0.2%)
Gastrointestinal disorders				
Constipation	85 (9.1%)	2 (0.2%)	32 (6.9%)	2 (0.4%)

a. Adverse Events (AEs) were considered Adverse Reactions if the incidences of AEs in the Xtandi group were greater than those in the placebo group, and if the treatment differences were maintained when the event rates were adjusted per 100 patient-years of exposure.

b. Includes asthenia and fatigue.

c. Includes dizziness and vertigo.

d. Includes amnesia, memory impairment, cognitive disorder, and disturbance in attention.

PREVAIL Study: Chemotherapy-naïve Metastatic Prostate Cancer that Progressed on Androgen Deprivation Therapy

In the PREVAIL trial of patients with metastatic prostate cancer that progressed on a GnRH analogue or after bilateral orchiectomy and had not received prior cytotoxic chemotherapy, Xtandi was administered at a dose of 160 mg daily (N = 871) versus placebo (N = 844). The median duration of treatment was 17.5 months with Xtandi and 4.6 months with placebo. All patients continued on a GnRH analogue or had prior bilateral orchiectomy. Patients were allowed, but not required, to continue or initiate corticosteroids (maximum daily dose allowed was 10 mg prednisone or equivalent).

Table 3 shows adverse reactions occurring at an incidence of $\geq 2\%$ in patients randomized to Xtandi in the PREVAIL study.

Table 3: Adverse Reactions^a Occurring at an Incidence of $\geq 2\%$ in Patients Randomized to Xtandi in the PREVAIL Study				
System Organ Class/ MedDRA Preferred Term, MedDRA v16.0	Xtandi N = 871		Placebo N = 844	
	All Grades (%)	Grade 3-4 (%)	All Grades (%)	Grade 3-4 (%)
General disorders and administration site conditions				
Asthenic Conditions ^b	409 (47.0%)	30 (3.4%)	280 (33.2%)	24 (2.8%)
Influenza-like illness	21 (2.4%)	0 (0.0%)	12 (1.4%)	0 (0.0%)
Vascular disorders				
Hot Flush	157 (18.0%)	1 (0.1%)	66 (7.8%)	0
Hypertension	124 (14.2%)	63 (7.2%)	35 (4.1%)	19 (2.3%)
Nervous system disorders				
Mental Impairment Disorders ^c	52 (6.0%)	0	13 (1.5%)	2 (0.2%)
Restless Legs Syndrome	18 (2.1%)	1 (0.1%)	3 (0.4%)	0
Somnolence	19 (2.2%)	0 (0.0%)	6 (0.7%)	0 (0.0%)
Injury, poisoning and procedural complications				
Contusion	26 (3.0%)	0 (0.0%)	10 (1.2%)	0 (0.0%)
Fall	111 (12.7%)	14 (1.6%)	45 (5.3%)	6 (0.7%)
Non-Pathological Fracture	68 (7.8%)	18 (2.1%)	25 (3.0%)	9 (1.1%)
Reproductive system and breast disorder				
Gynecomastia	30 (3.4%)	0	12 (1.4%)	0
Ear and labyrinth disorders				
Vertigo	24 (2.8%)	1 (0.1%)	7 (0.8%)	0 (0.0%)
Infections and infestations				
Herpes Zoster	19 (2.2%)	0 (0.0%)	3 (0.4%)	1 (0.1%)
Respiratory, thoracic and mediastinal disorders				
Epistaxis	24 (2.8%)	0 (0.0%)	11 (1.3%)	1 (0.1%)

- a. Adverse Events (AEs) were considered Adverse Reactions if the incidences of AEs in the Xtandi group were greater than those in the placebo group, and if the treatment differences were maintained when the event rates were adjusted per 100 patient-years of exposure.
- b. Includes asthenia and fatigue.
- c. Includes amnesia, memory impairment, cognitive disorder, and disturbance in attention.

AFFIRM Study: Metastatic Castration-Resistant Prostate Cancer Following Chemotherapy

In the AFFIRM trial of patients with metastatic castration-resistant prostate cancer who maintained treatment with a GnRH analogue or who had previously undergone surgical castration and had received docetaxel therapy, Xtandi was administered at a dose of 160 mg

daily (N = 800) versus placebo (N = 399). The median duration of treatment with Xtandi was 8.3 months, while with placebo it was 3.0 months. Patients were allowed, but not required, to continue or initiate corticosteroids (e.g. prednisone).

Table 4 shows adverse reactions occurring at an incidence of $\geq 2\%$ in patients randomized to Xtandi in the AFFIRM study.

Table 4: Adverse Reactions^a Occurring at an Incidence of $\geq 2\%$ in Patients Randomized to Xtandi in the AFFIRM Study				
	Xtandi N = 800		Placebo N = 399	
System Organ Class/ MedDRA Preferred Term, MedDRA v11.0	All Grades (%)	Grade 3^b (%)	All Grades (%)	Grade 3^b (%)
General disorders and administration site conditions				
Fatigue	269 (33.6%)	50 (6.3%)	116 (29.1%)	29 (7.3%)
Injury, poisoning and procedural complications				
Fall	32 (4.0%)	2 (0.3%)	5 (1.3%)	0
Nervous system disorders				
Headache	93 (11.6%)	6 (0.8%)	22 (5.5%)	0
Psychiatric disorders				
Anxiety	51 (6.4%)	2 (0.3%)	16 (4.0%)	0
Skin and subcutaneous tissue disorders				
Dry skin	28 (3.5%)	0	5 (1.3%)	0
Pruritus	29 (3.6%)	0	5 (1.3%)	0
Vascular disorders				
Hot flush	162 (20.3%)	0	41 (10.3%)	0
Hypertension	49 (6.1%)	16 (2.0%)	11 (2.8%)	5 (1.3%)

- Adverse Events (AEs) were considered Adverse Reactions if the incidences of AEs in the Xtandi group were greater than those in the placebo group, and if the treatment differences were maintained when the event rates were adjusted for patient-years of exposure.
- Grade 4 and 5 events were not observed.

Cardiovascular

In randomized placebo-controlled phase 3 studies (AFFIRM, PREVAIL, PROSPER and ARCHES), ischemic heart disease was observed in 2.9 % of patients treated with enzalutamide compared to 1.3% of patients treated with placebo. Grade 3-5 ischemic events occurred in 1.8% of patients on the Xtandi arm compared to 0.7% on the placebo arm. Cardiac failure was observed in 1.7% of patients treated with enzalutamide compared to 0.8% treated with placebo. The following preferred terms were observed in at least 2 patients: angina pectoris, coronary artery disease, myocardial infarctions, acute myocardial infarction, acute coronary syndrome, angina unstable, myocardial ischemia, and arteriosclerosis coronary artery.

Less Common Clinical Trial Adverse Drug Reactions (< 2%)

In the Phase 3 clinical trials, the following less common (< 2%) and clinically significant adverse reactions were reported with higher frequencies in patients treated with Xtandi.

Psychiatric Disorders: Hallucinations (including hallucination, hallucination tactile and hallucination visual)

Infections and Infestations: Infections and sepsis with fatal outcome

Nervous System Disorders: Seizure

Gastrointestinal Disorders: Gastrointestinal bleeding

Abnormal Hematologic and Clinical Chemistry Findings

Table 5 below shows laboratory values of interest from the Phase 3 placebo-controlled trials (AFFIRM, PREVAIL, PROSPER and ARCHES)

Parameter	Xtandi N = 3173		Placebo N = 2282	
	All Grades N (%)	Grade 3-4 N (%)	All Grades N (%)	Grade 3-4 N (%)
Hematologic Parameters				
Neutrophils (low)	13 (0.4%)	5 (0.2%)	6 (0.3%)	3 (0.1%)
Chemistry Parameters				
AST	32 (1.0%)	7 (0.2%)	30 (1.3%)	4 (0.2%)
ALT	31 (1.0%)	9 (0.3%)	33 (1.4%)	6 (0.3%)
Bilirubin	5 (0.2%)	2 (0.1%)	3 (0.1%)	0

ALT: alanine aminotransferase; AST: aspartate aminotransferase.

Post-Market Adverse Drug Reactions

The following adverse reactions have been identified during the post-approval use of Xtandi. Because post-market events are reported voluntarily from a population of uncertain size, it is not always possible to reliably estimate their frequency or establish a causal relationship to drug exposure.

Gastrointestinal disorders: diarrhea, nausea, vomiting

Immune disorders: face, tongue, lip, or pharyngeal oedema

Nervous system disorders: posterior reversible encephalopathy syndrome (PRES)

Skin and subcutaneous tissue disorders: rash

DRUG INTERACTIONS

Overview

Enzalutamide is a substrate of CYP2C8 and, to a lesser extent, CYP3A4, both of which play a role in the formation of the active metabolite, N-desmethyl enzalutamide (M2). Therefore, the metabolism of enzalutamide may be influenced by medicinal products that affect CYP2C8 and CYP3A4 (see **ACTION AND CLINICAL PHARMACOLOGY**).

Drug-Drug Interactions

Potential for other medicinal products to affect enzalutamide exposures

CYP2C8 inhibitors: Following oral administration of the strong CYP2C8 inhibitor gemfibrozil (600 mg twice daily) to healthy male volunteers, the composite area under the plasma

concentration-time curve (AUC) of enzalutamide plus M2 increased 2.17-fold. Therefore, co-administration of Xtandi with CYP2C8 inhibitors (e.g. gemfibrozil) may increase the plasma exposure of enzalutamide and should be avoided if possible. If patients must be co-administered a strong CYP2C8 inhibitor, a dose adjustment is recommended (see **DOSAGE AND ADMINISTRATION**).

CYP3A4 inhibitors: Following oral administration of the strong CYP3A4 inhibitor itraconazole (200 mg once daily) to healthy male volunteers, the AUC of enzalutamide plus M2 increased by 1.28-fold. No dose adjustment is necessary when Xtandi is co-administered with inhibitors of CYP3A4.

CYP2C8 and CYP3A4 inducers: In a drug-drug interaction trial in healthy volunteers, a single 160 mg oral dose of Xtandi was administered alone or after multiple oral doses of rifampin 600 mg once daily (moderate CYP2C8 and strong CYP3A4 inducer). Rifampin decreased the AUC_{0-inf} of enzalutamide plus M2 by 37% with no effect on C_{max}. No dose adjustment is necessary when Xtandi is co-administered with inducers of CYP2C8 or CYP3A4. However, the concomitant use of strong CYP3A4 inducers with enzalutamide is not recommended.

Potential for Xtandi to affect exposures to other medicinal products

Enzyme induction: Enzalutamide is a strong inducer of CYP3A4 and a moderate inducer of CYP2C9 and CYP2C19. Co-administration of Xtandi (160 mg once daily) with single oral doses of sensitive CYP substrates in prostate cancer patients resulted in an 86% decrease in the AUC of midazolam (CYP3A4 substrate), a 56% decrease in the AUC of S-warfarin (CYP2C9 substrate), and a 70% decrease in the AUC of omeprazole (CYP2C19 substrate). An *in vitro* study suggests that CYP2B6, and uridine 5'-diphospho-glucuronosyltransferases (UGT1A1 and UGT1A4) are also induced by enzalutamide. Medicinal products with a narrow therapeutic range that are substrates of CYP3A4, CYP2B6, CYP2C9, CYP2C19, UGT1A1 and UGT1A4 should be avoided, as enzalutamide may decrease their exposure. Such substrates include, but are not limited to:

- Analgesics (e.g. fentanyl, tramadol)
- Antibiotics (e.g. clarithromycin, doxycycline)
- Anti-epileptics (e.g. carbamazepine, clonazepam, phenobarbital, phenytoin, primidone, valproic acid)
- Antigout agents (e.g. colchicine)
- Antipsychotics (e.g. haloperidol)
- Antithrombotics (e.g. acenocoumarol, dabigatran etexilate, warfarin, clopidogrel)
- Benzodiazepines (e.g. diazepam, midazolam)
- Beta blockers (e.g. bisoprolol, propranolol)
- Calcium channel blockers (e.g. diltiazem, felodipine, nicardipine*, nifedipine, verapamil)
- Cardiac glycosides (e.g. digoxin)
- Corticosteroids (e.g. dexamethasone, prednisone)
- Certain anti-cancer agents (e.g. cabazitaxel, irinotecan, sunitinib)
- HIV antivirals (e.g. indinavir, ritonavir)
- Immune modulators (e.g. cyclosporine, tacrolimus)

- Proton pump inhibitors (e.g. omeprazole)
- Statins metabolized by CYP3A4 (e.g. atorvastatin, simvastatin)
- Thyroid agents (e.g. levothyroxine)

*not marketed in Canada

If co-administration cannot be avoided, dose adjustment may be required to maintain therapeutic plasma concentrations. If Xtandi is co-administered with an anticoagulant metabolised by CYP2C9 (such as warfarin or acenocoumarol), additional International Normalised Ratio (INR) monitoring should be conducted.

In a drug-drug interaction study in patients with prostate cancer (n = 14), a single oral dose of 100 mg caffeine (CYP1A2 substrate) and 30 mg dextromethorphan (CYP2D6 substrate) was administered before and concomitantly with enzalutamide (after at least 49 days of dosing at 160 mg daily). Xtandi did not cause clinically meaningful changes in exposure to the CYP1A2 or CYP2D6 substrates.

In consideration of the long half-life of enzalutamide (5.8 days), effects on enzymes may persist for one month or longer after stopping Xtandi.

CYP2C8 substrates: Xtandi (160 mg once daily) did not cause a clinically relevant change in the AUC of pioglitazone (CYP2C8 substrate) and no dose adjustment is indicated when a CYP2C8 substrate is co-administered with Xtandi.

P-gp substrates: *In vitro*, enzalutamide and N-desmethyl enzalutamide (M2) are inducers and inhibitors of the efflux transporter P-gp, while the inactive carboxylic acid metabolite (M1) does not affect this transporter. The effect of enzalutamide on P-gp substrates has not been evaluated *in vivo* and, under conditions of clinical use, its effect is unknown. Medicinal products with a narrow therapeutic range that are substrates for P-gp (e.g. colchicine, dabigatran etexilate, digoxin) should be used with caution when administered concomitantly with Xtandi and may require dose adjustment to maintain optimal plasma concentrations.

BCRP, MRP2, OAT1, OAT3, OCT1, OCT2, OATP1B1 and OATP1B3: *In vitro*, enzalutamide and its major metabolites are inhibitors of breast cancer resistant protein (BCRP) and multidrug resistance-associated protein 2 (MRP2). The effects of enzalutamide on BCRP and MRP2 substrates have not been evaluated *in vivo*. Xtandi may increase the plasma concentrations of co-administered medicinal products that are BCRP or MRP2 substrates. Thus, oral medicinal products with a narrow therapeutic range that are BCRP or MRP2 substrates (e.g. methotrexate) should be used with caution when administered concomitantly with Xtandi and may require dose adjustments to maintain optimal plasma concentrations.

In vitro data indicate that enzalutamide and its major metabolites do not inhibit organic anion transporter 1 (OAT1) or OCT2 at clinically relevant concentrations. Based on *in vitro* data, the possibility of *in vivo* inhibition of OAT3, organic anion transporting polypeptide 1B1 (OATP1B1), OATP1B3 and OCT1 cannot be excluded. Therefore, enzalutamide may alter the pharmacokinetics of drugs that are substrates of OATP1B1/3 (e.g. statins), OAT3 (e.g. furosemide, methotrexate), and OCT1 (e.g. metformin). The effects of enzalutamide on these transporters have not been evaluated *in vivo*.

Drugs That Cause QT/QTc Prolongation

Caution should be observed if Xtandi is administered with drugs that cause QTc prolongation, including, but not limited to, the following: Class IA, IC, and III antiarrhythmics; antipsychotics (e.g. chlorpromazine, pimozide, haloperidol, droperidol, ziprasidone); antidepressants (e.g. fluoxetine, citalopram, venlafaxine, tricyclic/tetracyclic antidepressants (e.g. amitriptyline, imipramine)); opioids (e.g. methadone); macrolide antibiotics and analogues (e.g. erythromycin, clarithromycin, telithromycin, tacrolimus); quinolone antibiotics (e.g. moxifloxacin, levofloxacin); antimalarials (e.g. quinine, chloroquine); azole antifungals; domperidone; 5-HT₃ receptor antagonists (e.g. dolasetron, ondansetron); tyrosine kinase inhibitors (e.g. vandetanib, sunitinib, nilotinib, lapatinib); histone deacetylase inhibitors (e.g. vorinostat); beta-2 adrenoceptor agonists. Chemical/pharmacological classes are listed if some, although not necessarily all, class members have been implicated in QTc prolongation and/or *Torsade de Pointes* (see **ACTION AND CLINICAL PHARMACOLOGY, Cardiac Electrophysiology**).

Drug-Food Interactions

Food has no clinically significant effect on the extent of exposure (AUC) to enzalutamide. However, the peak plasma enzalutamide concentration (C_{max}) was 30% higher when administered to subjects in the fasted state. In clinical trials, Xtandi was administered without regard to food.

Drug-Herb Interactions

Products that contain St. John's wort might induce CYP3A, which may lead to decreased plasma concentrations of enzalutamide.

Drug-Laboratory Interactions

Interactions with laboratory tests have not been established.

DOSAGE AND ADMINISTRATION

Dosing Considerations:

Xtandi is for use in patients who are maintaining treatment with a GnRH analogue or who have had previously undergone surgical castration. Patients started on Xtandi who are receiving a GnRH analogue should continue to receive a GnRH analogue.

Recommended Dose and Dosage Adjustment

The recommended dose of Xtandi is 160 mg (four 40 mg capsules) as a single oral daily dose. Xtandi can be taken with or without food.

Co-administration of Xtandi with CYP2C8 inhibitors may increase the plasma exposure of enzalutamide and should be avoided if possible. In patients who must be co-administered a strong CYP2C8 inhibitor, reduce the Xtandi dose to 80 mg once daily.

If a patient experiences \geq Grade 3 toxicity or an intolerable side effect, withhold dosing for one week or until symptoms improve to \leq Grade 2, then resume at the same or a reduced dose (120 mg or 80 mg), if warranted.

Elderly patients: No dose adjustment is necessary for elderly patients (see **ACTION AND CLINICAL PHARMACOLOGY, Special Populations and Conditions**).

Patients with hepatic impairment: No dose adjustment is necessary for patients with mild, moderate or severe hepatic impairment (Child-Pugh Class A, B or C. An increased drug half-life however, has been observed in patients with severe hepatic impairment; see **ACTION AND CLINICAL PHARMACOLOGY, Special Populations and Conditions**).

Patients with renal impairment: No dose adjustment is necessary for patients with mild or moderate renal impairment (calculated creatinine clearance (CrCL) values \geq 30 ml/min; see **ACTION AND CLINICAL PHARMACOLOGY, Special Populations and Conditions**). The effect of severe renal impairment on enzalutamide pharmacokinetics has not been studied. Caution is advised in patients with severe renal impairment or end-stage renal disease (see **ACTION AND CLINICAL PHARMACOLOGY, Special Populations and Conditions**).

Missed Dose

If a patient misses taking Xtandi at the usual time, the prescribed dose should be taken as close as possible to the usual time. If a patient misses a dose for a whole day, treatment should be resumed the following day with the usual daily dose.

Administration

Xtandi capsules should be swallowed whole with water, and can be taken with or without food. Do not chew, dissolve or open the capsules.

OVERDOSAGE

There is no antidote for Xtandi. In the event of an overdose, stop treatment with Xtandi and initiate general supportive measures taking into consideration the half-life of 5.8 days. It is unlikely that enzalutamide will be significantly removed by intermittent hemodialysis or continuous ambulatory peritoneal dialysis, owing to its large volume of distribution and low unbound free fraction.

Patients may be at increased risk of seizures following an overdose.

For management of a suspected drug overdose, contact your regional Poison Control Centre.

ACTION AND CLINICAL PHARMACOLOGY

Mechanism of Action

Enzalutamide is an androgen receptor inhibitor that acts on several steps in the androgen receptor signalling pathway. Enzalutamide competitively inhibits binding of androgens to androgen

receptors and, as a result, inhibits translocation of androgen receptors and association of androgen receptors with DNA. The active metabolite (M2) exhibited similar *in vitro* activity to enzalutamide. Enzalutamide treatment decreased proliferation and induced cell death of prostate cancer cells *in vitro*, and decreased tumour volume in a mouse prostate cancer xenograft model. In preclinical studies, enzalutamide lacked androgen receptor agonist activity in cell growth assays using LNCaP cells expressing clinically relevant mutant ARs (T877A and/or W741C).

Pharmacodynamic Effects

In the Phase 3 clinical study of patients who failed prior chemotherapy with docetaxel (AFFIRM), 54% of patients treated with Xtandi, versus 1.5% of patients who received placebo, had at least a 50% decline from baseline in PSA levels.

Cardiac Electrophysiology

A comprehensive ECG assessment was embedded in the placebo-controlled Phase 3 AFFIRM study. ECGs were collected at baseline and prior to dosing on weeks 2, 5, 9, 13, 17, 21, and 25 and every 12 weeks thereafter. Enzalutamide 160 mg QD was associated with statistically significant QTc prolongation. During steady-state treatment, the placebo-adjusted mean increase from baseline in the QTcF interval ranged from 3.0 to 6.5 milliseconds between weeks 5 and 25. The magnitude of QTc prolongation at maximal concentrations of enzalutamide was predicted to be 6.0 ms, with a one-sided upper 95% confidence interval bound of 7.0 ms, using pharmacokinetic/pharmacodynamic modeling.

Blood Pressure

Serial blood pressure assessments were performed in the placebo-controlled Phase 3 AFFIRM study. Statistically significant mean differences from placebo in systolic blood pressure were observed at most time points during steady-state treatment (weeks 5, 9, 17, 21, and 25), with point estimates in the range of 2-4 mm Hg and one-sided 95% CI upper bounds up to 7.4 mm Hg. Statistically significant mean differences from placebo in diastolic blood pressure were observed at weeks 5, 9, 13, 17, and 21, with point estimates ranging from approximately 1-4 mm Hg and one-sided 95% CI upper bounds as high as 5.2 mm Hg.

Pharmacokinetics

Table 6: Arithmetic Mean ± SD (CV%) Pharmacokinetic Parameters of Xtandi in Adult Subjects							
Study Number	Dosage Regimen	Subject Population	C _{max} (µg/mL)	AUC (µg•h/mL) ^a	t _{1/2} (h)	CL/F (L/h)	V/F (L)
MDV3100-05	160 mg ^b single dose (fasted)	Healthy volunteers (n = 27)	5.25 ± 1.06 (20%)	292 ± 88 (30%)	94.3 ± 30.0 (32%)	0.600 ± 0.193 (32%)	76.4 ± 21.9 (29%)
	160 mg ^b single dose (fed)	Healthy volunteers (n = 30)	3.74 ± 1.15 (31%)	285 ± 73 (26%)	87.4 ± 24.7 (28%)	0.599 ± 0.160 (27%)	71.9 ± 16.6 (23%)
S-3100-1-01	150 mg ^c single dose	CRPC patients (n = 3)	3.36 ± 0.78 (23%)	334 ± 50 (15%)	143.7 ± 34.8 (24%)	0.456 ± 0.064 (14%)	92.4 ± 11.8 (13%)
	150 mg ^c once daily (day 84)	CRPC patients (n = 23)	14.46 ± 3.29 (23%)	300 ± 68 (23%)	Not applicable	0.530 ± 0.149 (28%)	Not applicable
9785-CL-0009	160 mg ^b (fasted)	Subjects with MHI (n = 8)	3.68 ± 2.09 (57%)	303 ± 126 (41%)	196 ± 185 (94%)	0.604 ± 0.229 (38%)	142 ± 105 (74%)
	[matched subjects]	Subjects with NHF (n = 8)	3.83 ± 0.822 (22%)	225 ± 50.7 (23%)	108 ± 53.3 (49%)	0.753 ± 0.213 (28%)	109 ± 40.9 (38%)

a. AUC_{inf} and AUC_τ (steady-state) were calculated in single dose and multiple dose studies, respectively;

b. Administered as 4 x 40 mg soft gelatin capsules;

c. Administered as 5 x 30 mg hard gelatin capsules.

CRPC: Castration-resistant prostate cancer; MHI: moderate hepatic impairment; NHF: normal hepatic function.

The pharmacokinetics of enzalutamide have been evaluated in metastatic castration-resistant prostate cancer patients and in healthy male volunteers.

Absorption: Following oral administration of Xtandi 160 mg in patients with metastatic castration-resistant prostate cancer, the median time to reach maximum plasma enzalutamide (t_{max}) was 1.02 h (range 0.52 h to 3.02 h). With the daily dosing regimen, steady-state is achieved after approximately 28 days, and enzalutamide accumulates approximately 8.3-fold relative to a single dose. At steady-state, the active metabolite M2 circulates at approximately the same plasma concentration as enzalutamide; the mean C_{max} values for enzalutamide and M2 were 16.6 µg/mL (23% CV) and 12.7 µg/mL (30% CV), respectively. The steady-state C_{min} values of enzalutamide (11.4 µg/mL) and M2 (13.0 µg/mL) in individual patients remained constant during more than one year of chronic therapy, demonstrating time-linear pharmacokinetics once steady-state is achieved. The plasma concentration of the inactive metabolite M1 was approximately 75% that of enzalutamide at steady-state. Daily fluctuations in plasma concentrations are low (peak-to-trough ratio of 1.25). No major deviations from dose proportionality are observed over the dose range 30 to 360 mg.

Based on a mass balance study in healthy volunteers, oral absorption of enzalutamide is estimated to be at least 84.2%. Enzalutamide is not a substrate of the efflux transporters P-gp or BCRP.

Food has no clinically significant effect on the extent of absorption (Table 6). However, the peak plasma enzalutamide concentration (C_{max}) was 30% higher when administered to subjects in the fasted state. In clinical trials, Xtandi was administered without regard to food.

Distribution: The mean apparent volume of distribution (V/F) of enzalutamide in patients after a single oral dose is 110 L (29% CV). The volume of distribution of enzalutamide is greater than the volume of total body water, indicative of extensive extravascular distribution.

Studies in rodents indicate that enzalutamide and M2 can cross the blood brain barrier.

Enzalutamide is 97% to 98% bound to plasma proteins, primarily albumin. The active metabolite (M2) is 95% bound to plasma proteins. There is no protein binding displacement between enzalutamide and other highly bound drugs (warfarin, ibuprofen, and salicylic acid) *in vitro*.

Metabolism: Enzalutamide is extensively metabolized. There are two major metabolites in human plasma: N-desmethyl enzalutamide (M2, active) and a carboxylic acid derivative (M1, inactive).

In vitro studies show that enzalutamide is metabolized by CYP2C8 and, to a lesser extent, by CYP3A4/5, both of which play a role in the formation of the active metabolite (M2).

Enzalutamide is not metabolized *in vitro* by CYP1A1, CYP1A2, CYP2A6, CYP2B6, CYP2C9, CYP2C18, CYP2C19, CYP2D6, or CYP2E1.

In addition, *in vitro* data show that M2 is metabolized to M1 by carboxylesterase 1, which also plays a minor role in the metabolism of enzalutamide to the M1. Carboxylesterase 2 does not appear to play a role in the metabolism of either enzalutamide or M2.

Following a single oral dose of 160 mg ^{14}C -enzalutamide to healthy volunteers, a total of 7 Phase I metabolites were identified in plasma, urine, and feces. These metabolites were formed via demethylation, oxidation, and hydrolysis reactions. No Phase II conjugation products were observed. Enzalutamide, N-desmethyl enzalutamide (M2, active) and a carboxylic acid derivative (M1, inactive) accounted for 88% of the ^{14}C -radioactivity in plasma, representing 30%, 49%, and 10%, respectively, of the total ^{14}C -AUC_{0-inf}.

Excretion: Clearance of enzalutamide is primarily via renal excretion of hepatic metabolites. Following a single oral dose of 160 mg ^{14}C -enzalutamide to healthy volunteers, 84.6% of the radioactivity is recovered by 77 days post dose: 71.0% is recovered in urine (primarily as M1, with trace amounts of enzalutamide and M2), and 13.6% is recovered in feces (0.39% of dose as unchanged enzalutamide).

The mean apparent clearance (CL/F) of enzalutamide is between 0.520 and 0.564 L/h in patients and 0.596 to 0.753 L/h in healthy volunteers.

The mean $t_{1/2}$ of enzalutamide in patients is 5.8 days, while the mean $t_{1/2}$ of enzalutamide is shorter in healthy volunteers, averaging 2.9 to 4.8 days. The $t_{1/2}$ of M1 and M2 in patients has not been evaluated. The mean $t_{1/2}$ for M1 in healthy volunteers ranges from 7.8 to 9.3 days, and the mean $t_{1/2}$ for M2 in healthy volunteers ranges from 7.5 to 8.8 days, respectively. The $t_{1/2}$ does not appear to be affected by dose.

Special Populations and Conditions

Pediatrics (≤ 18 years of age): The pharmacokinetics of enzalutamide has not been evaluated in pediatric patients.

Geriatrics (≥ 65 years of age): Of the 2601 patients in the Phase 3 clinical trials who received Xtandi, 2070 patients (80%) were 65 years and over and 958 patients (37%) were 75 years and over. Based on the population pharmacokinetic analysis for age, no dose adjustment is necessary in the elderly.

Gender: The pharmacokinetics of enzalutamide has not been evaluated in women.

Race: The majority of patients in the randomized clinical trials were Caucasian ($\sim 74\%$). Based on pharmacokinetic data from a study in Japanese patients with prostate cancer, there were no clinically relevant differences in exposure between Japanese and Caucasians. There are insufficient data to evaluate potential differences in the pharmacokinetics of enzalutamide in other races.

Hepatic Insufficiency: The pharmacokinetics of enzalutamide were examined in subjects with baseline mild ($n = 6$) or moderate ($n = 8$) hepatic impairment (Child-Pugh Class A and B, respectively) and in 14 matched control subjects with normal hepatic function. Following a single oral 160 mg dose of Xtandi, the enzalutamide plus M2 AUC increased by 1.13-fold in subjects with mild hepatic impairment, and 1.18-fold in subjects with moderate hepatic impairment, compared to healthy control subjects.

In a separate study, subjects with severe hepatic impairment (Child-Pugh C; $n = 8$) and matched healthy control subjects with normal hepatic function ($n = 8$) were evaluated. Following a single oral 160 mg dose of enzalutamide, the AUC and C_{max} for enzalutamide plus M2 in subjects with severe hepatic impairment increased by 1.04-fold and decreased by 0.58-fold, respectively, compared to healthy control subjects. An increased drug half-life was observed in patients with severe hepatic impairment, possibly related to increased tissue distribution. The clinical relevance of this observation remains unknown. Patients with baseline severe hepatic impairment (Child-Pugh C) were excluded from both the AFFIRM and PREVAIL trials.

Overall, the results indicate that no dose adjustment is necessary for patients with baseline mild, moderate or severe hepatic impairment.

Renal Insufficiency: No formal renal impairment study for Xtandi has been completed. Patients with serum creatinine $> 177 \mu\text{mol/l}$ (2 mg/dl) were excluded from clinical trials. Based on a

population pharmacokinetic analysis, no dose adjustment is necessary for patients with calculated creatinine clearance (CrCL) values ≥ 30 ml/min (estimated by the Cockcroft and Gault formula). Xtandi has not been evaluated in patients with severe renal impairment (CrCL < 30 ml/min) or end-stage renal disease, and caution is advised when treating these patients. It is unlikely that enzalutamide will be significantly removed by intermittent hemodialysis or continuous ambulatory peritoneal dialysis.

Genetic Polymorphism: No formal study has been completed to assess the effect of genetic polymorphisms on exposure or response.

STORAGE AND STABILITY

Store Xtandi (enzalutamide capsules) at controlled room temperature 15°C - 30°C.

SPECIAL HANDLING INSTRUCTIONS

Xtandi should not be handled by persons other than the patient or his caregivers. Based on its mechanism of action and embryo-fetal toxicity observed in mice, enzalutamide may harm a developing fetus. Women who are or may become pregnant should not handle damaged or opened Xtandi capsules without protection (e.g. gloves). Do not dissolve or open the capsules.

DOSAGE FORMS, COMPOSITION AND PACKAGING

Xtandi (enzalutamide capsules) is supplied as a liquid-filled, white-to-off-white, oblong, soft gelatin capsule imprinted in black ink with “ENZ”. Each capsule contains 40 mg of enzalutamide and the inactive ingredients caprylocaproyl macrogolglycerides, butylhydroxyanisole and butylhydroxytoluene.

The ingredients of the capsule shell are gelatin, sorbitol sorbitan solution, glycerol, titanium dioxide (E171), and purified water.

The ingredients of the ink are: ethanol, ethyl acetate, propylene glycol, iron oxide black (E172), polyvinyl acetate phthalate, purified water, isopropyl alcohol, macrogol 400, and ammonia solution concentrated.

Xtandi capsules are available in the following package sizes:

- Bottles of 120 capsules
- Blister Cartons of 112 capsules (4 capsules per cavity, 28 capsules per wallet)

Do not use beyond expiration date indicated on the package.

PART II: SCIENTIFIC INFORMATION

PHARMACEUTICAL INFORMATION

Drug Substance

Proper name:	enzalutamide
Chemical names:	
IUPAC	4-{3-[4-Cyano-3-(trifluoromethyl)phenyl]-5,5-dimethyl-4-oxo-2-thioxoimidazolidin-1-yl}-2-fluoro- <i>N</i> -methylbenzamide
Alternate names	4-{3-[4-Cyano-3-(trifluoromethyl)phenyl]-5,5-dimethyl-4-oxo-2-sulfanylideneimidazolidin-1-yl}-2-fluoro- <i>N</i> -methylbenzamide 3-(4-Cyano-3-trifluoromethylphenyl)-1-[3-fluoro-4-(methylcarbamoyl)phenyl]-5,5-dimethyl-2-thioxoimidazolin-4-one Benzamide, 4-[3-[4-cyano-3-(trifluoromethyl)phenyl]-5,5-dimethyl-4-oxo-2-thioxo-1-imidazolidinyl]-2-fluoro- <i>N</i> -methyl
Molecular formula:	C ₂₁ H ₁₆ F ₄ N ₄ O ₂ S
Molecular mass:	464.44
Structural formula:	

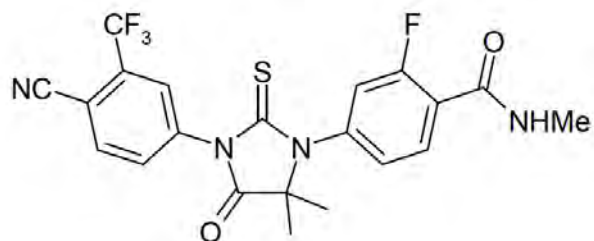

Physicochemical properties:	Enzalutamide is a white-to-off white solid that is insoluble in water. No salts are formed from pH 2 to 10. One crystalline form and four solvates have been observed.
-----------------------------	--

CLINICAL TRIALS

The efficacy of Xtandi (enzalutamide) was established in four randomized placebo-controlled multicentre Phase 3 clinical studies (PREVAIL, AFFIRM, PROSPER, ARCHES) of patients with progressive non-metastatic (PROSPER) or metastatic prostate cancer (AFFIRM, PREVAIL) who had failed androgen deprivation therapy [Gonadotropin-releasing hormone (GnRH) analogue or after bilateral orchiectomy] and patients with metastatic castration-sensitive prostate cancer (ARCHES). All patients continued on a GnRH analogue or had prior bilateral orchiectomy.

Metastatic Castration-Sensitive Prostate Cancer (ARCHES)

Study demographics and trial design

The ARCHES study enrolled 1150 patients with mCSPC randomized 1:1 to receive treatment orally once daily with Xtandi 160 mg (N=574) or placebo (N=576). All patients in the trial received a GnRH analog or had a prior bilateral orchiectomy. Patients were stratified by volume of disease (low vs high) and prior docetaxel therapy for prostate cancer (no prior docetaxel, 1-5 cycles, or 6 prior cycles). Treatment with concurrent docetaxel was not allowed. Patients were required to have confirmation of metastatic prostate cancer by positive bone scan or metastatic lesions on CT or MRI scan. Patients continued treatment until radiographic disease progression, initiation of new treatment, unacceptable toxicity, or withdrawal.

Radiographic progression-free survival (rPFS) was the primary endpoint defined as the time from randomization to the first objective evidence of radiographic disease progression or death (any cause from time of randomization through 24 weeks after study drug discontinuation), whichever occurred first. Key secondary efficacy endpoints assessed in the study were time to PSA progression, time to start of new antineoplastic therapy, PSA undetectable rate (decline to <0.2 µg/L), objective response rate (RECIST 1.1) based on independent review, time to deterioration of urinary symptoms, and overall survival.

The demographic and baseline disease characteristics were balanced between the two treatment arms (Table 7).

Baseline Characteristic	Xtandi (N = 574)	Placebo (N = 576)
Age category (years), n (%)		
< 65	148 (25.8)	152 (26.4)
65 to < 75	256 (44.6%)	255 (44.3%)
≥ 75	170 (29.6%)	169 (29.3%)
Age (years)		
Mean (SD)	69.5 (8.0%)	69.5 (5.4%)
Median (minimum, maximum)	70.0 (46, 92)	70.0 (42, 92)
Race, n (%)		
White	466 (81.2%)	460 (79.9%)
Black or African American	8 (1.4%)	8 (1.9%)

Table 7: ARCHES Key Demographics and Baseline Disease Characteristics (ITT Population)		
Baseline Characteristic	Xtandi (N = 574)	Placebo (N = 576)
Asian	75 (13.1%)	80 (13.9%)
Other	2 (0.3%)	3 (0.5%)
Missing	23 (4.0%)	25 (4.3%)
Ethnicity, n (%)		
Hispanic or Latino	46 (8.0%)	37 (6.4%)
Not Hispanic or Latino	504 (87.8%)	514 (89.2%)
Missing	24 (4.2%)	25 (4.3%)
Weight (kg)		
n	573	575
Mean (SD)	81.25 (16.17)	81.26 (16.22)
Median (minimum, maximum)	80.00 (42.7, 163.0)	80.00 (39.1, 157.5)
Body mass index (kg/m²)		
N	567	570
Mean (SD)	27.20 (4.44)	27.21 (4.61)
Median (minimum, maximum)	26.65 (16.7, 45.2)	26.91 (16.4, 48.8)
ECOG performance status at study entry, n (%)		
0	448 (78.0)	443 (76.9)
1	125 (21.8)	133 (23.1)
Baseline serum PSA^a (ng/mL)		
n	572	574
Mean (SD)	75.37 (356.36)	104.78 (834.48)
Median (minimum, maximum)	5.36 (0.0, 4823.5)	5.07 (0.0, 19000.0)
Total Gleason score at initial diagnosis, n (%)		
< 8	171 (29.8)	187 (32.5)
≥ 8	386 (67.2)	373 (64.8)
Volume of disease^b, n (%)		
Low	220 (38.3)	203 (35.2)
High	354 (61.7)	373 (64.8)
Prior docetaxel therapy^b, n (%)		
None	471 (82.1)	474 (82.3)
1 to 5 cycles	14 (2.4)	11 (1.9)
6 cycles	89 (15.5)	91 (15.8)
Previous use of ADT, n (%)		
None	39 (6.8)	61 (10.6)
≤ 3 months	414 (72.1)	394 (68.4)
> 3 months	121 (21.1)	120 (20.8)
Unknown ^c	0	1 (0.2)

All patients who were randomized in the study (ITT population).

The analysis data cutoff date was 14 Oct 2018.

ADT: androgen deprivation therapy; ECOG: Eastern Cooperative Oncology Group; ICR: independent central review; ITT: intent-to-treat; PSA: prostate-specific antigen

- a. PSA levels of 0 were observed, which could have been due to prior treatment with docetaxel and/or use of ADT within 3 months of study start. One patient receiving placebo plus ADT had a baseline PSA level of > 19000 ng/mL, which impacted the calculation of mean baseline PSA for this group.
- b. Volume of disease and prior docetaxel therapy were stratification factors at randomization. High volume of disease is defined as metastases involving the viscera or, in the absence of visceral lesions, there must be 4 or more bone lesions, at least 1 of which must be in a bony structure beyond the vertebral column and pelvic bone.
- c. The patient had ADT; however, the duration of ADT use was not known.

Study Results

Xtandi demonstrated a statistically significant 61% reduction in the risk of an rPFS event compared to placebo [HR = 0.39 (95% CI: 0.30, 0.50); $p < 0.0001$]. The median time to an rPFS event was not reached in the enzalutamide plus ADT arm and was 19.0 months (95% CI: 16.6, 22.2) in the placebo plus ADT arm (Table 8, Figure 1).

The rPFS results were further supported by clinically meaningful and statistically significant improvements in 4 key secondary endpoints. The OS data was considered to be immature at the time of analysis. The median follow-up for OS was 14.4 months. Additionally, assessments of Patient Reported Outcomes data showed that patients enrolled in ARCHES had a high baseline level of Quality of Life, which was maintained over time.

Table 8: Summary of efficacy results in the ARCHES study (intent-to-treat analysis)		
	Xtandi (N = 574)	Placebo (N = 576)
Primary Endpoint		
Radiographic Progression-free Survival		
Number of Events (%)	91 (15.9)	201 (34.9)
Median, months (95% CI) ^a	NR	19.0 (16.6, 22.2)
Hazard Ratio (95% CI) ^b	0.39 (0.30, 0.50)	
P-value ^b	$p < 0.0001$	
Key Secondary Efficacy Endpoints		
Time to PSA progression^c		
Number of Events (%)	45 (7.8)	189 (32.8)
Median, months (95% CI) ^a	NR	NR (16.6, NR)
Hazard Ratio (95% CI) ^b	0.19 (0.13, 0.26)	
P-value ^b	$p < 0.0001$	
Time to first use of new antineoplastic therapy		
Number of Events (%)	46 (8.0)	133 (23.1)
Median, months (95% CI) ^a	30.2 (NR, NR) ^d	NR (21.1, NR)
Hazard Ratio (95% CI) ^b	0.28 (0.20, 0.40)	
P-value ^b	$p < 0.0001$	
PSA Undetectable Rates		
Patients with PSA detectable at baseline	511	506
Patients with PSA undetectable at baseline	63	70
Undetectable PSA during treatment period	348/511 (68.1)	89/506 (17.6)
95% CI for rate	(63.9, 72.1)	(14.4, 21.2)
Difference in rate (95% CI) ^b	50.5% (45.3, 55.7)	
P-value	$p < 0.0001$	

Table 8: Summary of efficacy results in the ARCHES study (intent-to-treat analysis)		
	Xtandi (N = 574)	Placebo (N = 576)
Objective Response Rate		
Patients with PSA detectable at baseline	177	182
Number of events (%)	147 (83.1)	116 (63.7)
95% CI for rate	(76.7, 88.3)	(56.3, 70.7)
Difference in rate (95% CI) ^b	19.3% (10.4, 28.2)	
P-value	p < 0.0001	
Time to deterioration in urinary symptoms^e		
Events, n (%)	184 (32.06)	201 (34.90)
Kaplan-Meier median (95% CI) ^k (months)	NR (19.35, NR)	16.8 (14.06, NR)
Hazard Ratio (95% CI) ^b	0.88 (0.72, 1.08)	
P-value ^b	p = 0.2162	
Overall survival interim analysis^f		
Events, n (%)	39 (6.79)	45 (7.81)
Kaplan-Meier median (95% CI) ^k (months)	NR	NR
Hazard Ratio (95% CI) ^b	0.81 (0.53, 1.25)	
P-value ^b	p = 0.3361	
Other Secondary Efficacy Endpoints		
Time to first SSE (Symptomatic Skeletal Event)^g		
Patients with SSE events, n (%)	31 (5.40)	56 (9.72)
Median, months (95% CI) ^a	NR	NR
Hazard ratio (95% CI) ^b	0.52 (0.33, 0.80)	
P-value (nominal) ^b	p = 0.0026	
Time to castration resistance^h		
Events, n (%)	90 (15.68)	257 (44.62)
Kaplan-Meier median (95% CI) ^k (months)	NR	13.9 (11.40, 17.18)
Hazard ratio (95% CI) ^b	0.28 (0.22, 0.36)	
P-value (nominal) ^b	p < 0.0001	
Time to deterioration of quality of lifeⁱ		
Events, n (%)	280 (48.78)	274 (47.57)
Kaplan-Meier median (95% CI) ^k (months)	11.3 (11.04, 13.83)	11.1 (8.48, 13.83)
Hazard ratio (95% CI) ^b	0.96 (0.81, 1.14)	
P-value (nominal) ^b	p = 0.6548	
Time to pain progression^j		
Events, n (%)	324 (56.45)	329 (57.12)
Kaplan-Meier median (95% CI) ^k (months)	8.3 (8.25, 10.91)	8.3 (5.65, 8.38)
Hazard ratio (95% CI) ^b	0.92 (0.78, 1.07)	
P-value (nominal) ^b	0.2715	
NR = Not reached		
a. Calculated using Brookmeyer and Crowley method		
b. Stratified by volume of disease (low vs high) and prior docetaxel use (yes or no)		
c. PSA progression was defined as a $\geq 25\%$ increase and an absolute increase of ≥ 2 $\mu\text{g/L}$ above nadir		
d. While an estimate of the median time was provided for the enzalutamide plus ADT arm (30.2 months), this estimate was not reliable as it resulted from an event observed in the only remaining patient at risk at approximately 30 months, leading to a vertical drop at the end of the Kaplan-Meier curve.		
e. A deterioration in urinary symptoms was defined as an increase in the QLQ-PR25 modified urinary symptoms score by $\geq 50\%$ of the standard deviation observed in the QLQ-PR25 modified urinary symptoms score at baseline.		

Table 8: Summary of efficacy results in the ARCHES study (intent-to-treat analysis)

	Xtandi (N = 574)	Placebo (N = 576)
	In patients with a deterioration in urinary symptoms, the time to deterioration in urinary symptoms was defined as the time interval between randomization and the first deterioration in urinary symptoms. In patients without a deterioration in urinary symptoms the time to deterioration in urinary symptoms was censored on the date that the last urinary symptoms QLQ-PR25 score was calculable.	
f.	Time from randomization to death from any cause. For patients still alive at the date of the analysis cutoff point, overall survival was censored on the last date the patient was known to be alive. The analysis was performed at a level of significance of 0.0000054, based on an O'Brien-Fleming boundary with 84 events.	
g.	An SSE was defined as radiation or surgery to bone, clinically apparent pathological bone fracture or spinal cord compression whichever occurred first. Time to the first SSE was the time from randomization to the occurrence of the first SSE. In patients with no SSE, time to SSE was censored on the last visit date or the date of randomization, whichever occurred last.	
h.	A castration resistance event was defined as an occurrence of radiographic disease progression by ICR, PSA progression or an SSE with castration levels of testosterone (< 50 ng/mL), whichever occurred first. In patients with a castration resistance event, the time to castration resistance was the time from randomization to the first castration resistance event. In patients with no documented castration resistance event, the time to castration resistance was censored on the latest date from the following: the last radiologic assessment, the last PSA sample taken prior to the start of any new prostate cancer therapy and prior to 2 or more consecutive missed PSA assessments or the last visit date performed.	
i.	Deterioration of QoL was defined as a decrease from baseline of a least 10 points in the FACT-P total score. In patients with a deterioration in QoL, the time to deterioration in QoL was the time interval from the date of randomization to the first date a decline from baseline of 10 points or more in the FACT-P total score was recorded. In patients without FACT-P progression, the time to deterioration of QoL was censored on the date that the last FACT-P total score was calculable.	
j.	Pain progression was defined as an increase of $\geq 30\%$ from baseline in the average BPI-SF item scores. In patients with pain progression, time to pain progression was defined as the time from randomization to the first pain progression event. In patients with no pain progression event, time to pain progression was censored on the last visit date where BPI-SF data were collected.	
k.	Calculated by Brookmeyer and Crowley method.	

Figure 1 Kaplan-Meier Curve of rPFS in ARCHES study (Intent-to-Treat Analysis)

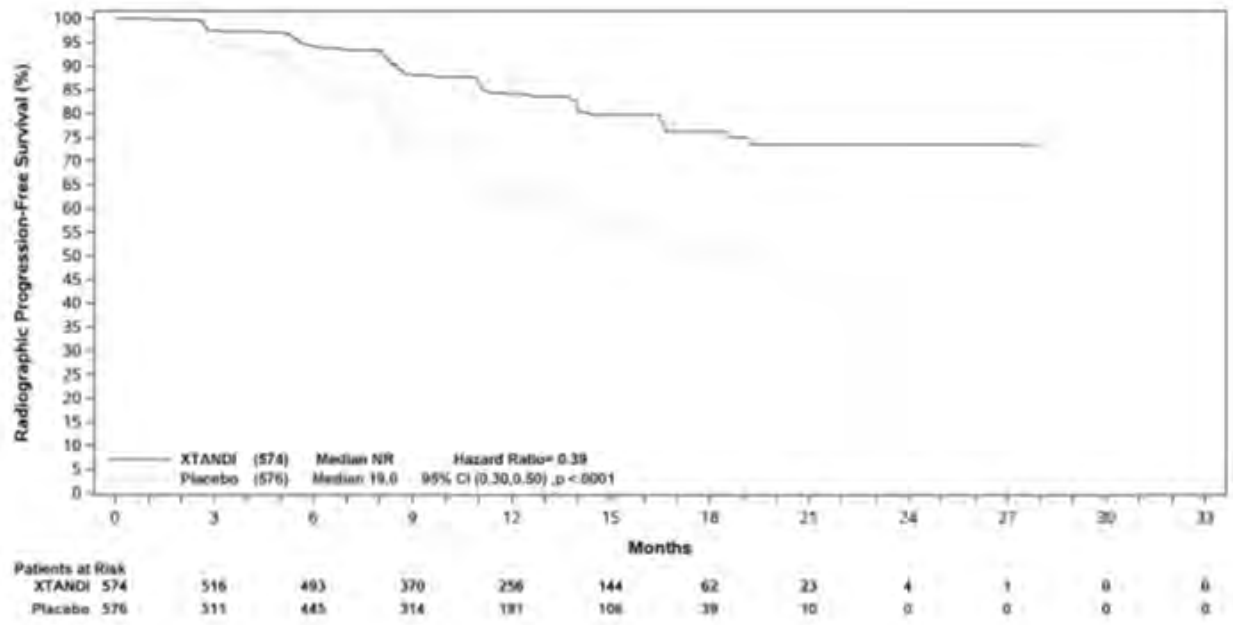
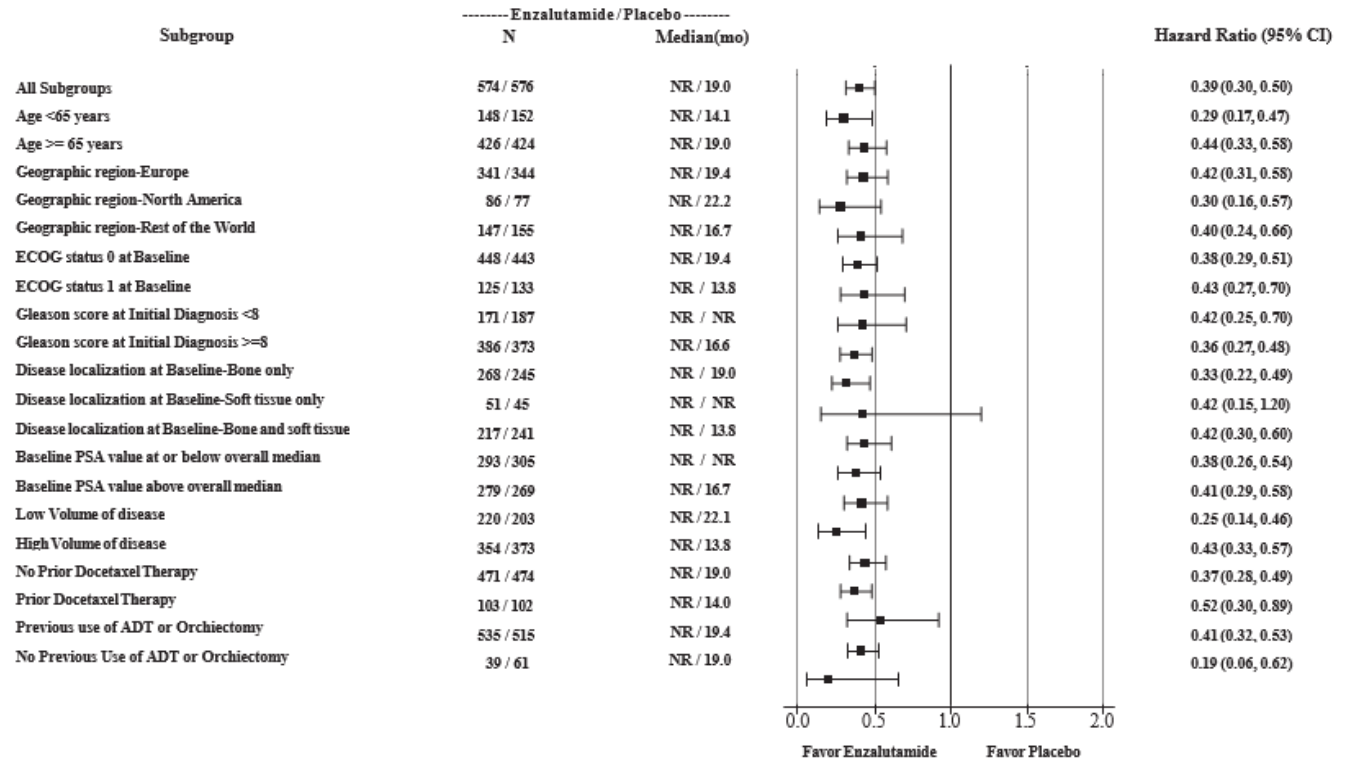

Figure 2 Forest Plot of rPFS by Prespecified Subgroup in ARCHES (Intent-to-Treat Analysis)



Non-Metastatic Prostate Cancer that Progressed on Androgen Deprivation Therapy (PROSPER)

Study demographics and trial design

The PROSPER study enrolled 1401 patients with non-metastatic CRPC who continued on androgen deprivation therapy (ADT; defined as GnRH analogue or prior bilateral orchiectomy). Patients were randomized 2:1 to receive either Xtandi at a dose of 160 mg once daily (N = 933) or placebo (N = 468).

Patients discontinued treatment for radiographic disease progression confirmed by blinded independent central review (BICR), unacceptable toxicity, initiation of new treatment, or withdrawal. PSA results were blinded and were not used for treatment discontinuation.

Patients were required to have a PSA doubling time ≤ 10 months (considered to be at high risk of developing metastatic disease), PSA ≥ 2 ng/mL, and confirmation of non-metastatic disease by (BICR) using conventional scans.

Metastasis-free survival (MFS) was the primary endpoint defined as the time from randomization to loco-regional and/or distant radiographic progression or death within 112 days of treatment discontinuation without evidence of radiographic progression, whichever occurred first. Radiographic progression for bone disease was defined as the appearance of 1 or more metastatic lesions on the bone assessed by whole-body radionuclide bone scan, while assessment of soft tissue disease was performed by CT or MRI performed every 16 weeks (earlier if progression was clinically suspected). Radiographic progression for soft tissue disease was defined by RECIST 1.1.

Key secondary endpoints assessed in the study were time to PSA progression time to first use of new antineoplastic therapy and overall survival. PSA progression was defined according to PCWG2 guidelines; time to PSA progression was defined as the time from randomization to the date of first PSA value demonstrating progression, which was subsequently confirmed.

The demographic and baseline characteristics were balanced between the two treatment arms (Table 9). The median age at randomization was 74 years in the Xtandi arm and 73 years in the placebo arm.

Fifty-four percent (54%) of patients received prior treatment for prostate cancer with either surgery or radiation. Sixty-three percent (63%) of patients received prior treatment with an anti-androgen; 56% of patients received bicalutamide and 11% of patients received flutamide.

Baseline Characteristic	Xtandi (N = 933)	Placebo (N = 468)
Age (years)		
Mean (SD)	73.8 (7.83)	72.9 (7.63)
Min, Max	50, 95	53, 92
Race		

Table 9: PROSPER Key Demographics and Baseline Disease Characteristics (ITT Population)		
Baseline Characteristic	Xtandi (N = 933)	Placebo (N = 468)
White	671 (71.9%)	320 (68.4%)
Other, multiple, or unknown	99 (10.6%)	50 (10.7%)
Asian	142 (15.2%)	88 (18.8%)
Black	21 (2.3%)	10 (2.1%)
Time from initial diagnosis to randomization, months		
Mean (SD)	99.1 (57.27)	94.1 (56.73)
Median (minimum, maximum)	90.4 (2.2, 381.8)	86.8 (2.2, 275.7)
Total Gleason Score at initial diagnosis, n (%)		
Low (2 to 4)	21 (2.3%)	12 (2.6%)
Medium (5 to 7)	491 (52.6%)	230 (49.1%)
High (8 to 10)	381 (40.8%)	207 (44.2%)
Unknown or missing	40 (4.3%)	19 (4.1%)
Baseline use of BTA		
No	828 (88.7%)	420 (89.7%)
Yes	105 (11.3%)	48 (10.3%)
1	103 (11.0%)	47 (10.0%)
2	2 (0.2%)	1 (0.2%)
PSA Doubling Time Category n (%)		
< 6 months	715 (76.6%)	361 (77.1%)
≥ 6 months	217 (23.3%)	107 (22.9%)
Missing	1 (0.1%)	0
Baseline serum PSA (ng/mL)		
N	933	468
Mean (SD)	22.2 (46.14)	22.1 (41.08)
Median	11.1	10.2
Min, max	0.8, 1071.1	0.2, 467.5
Baseline ECOG performance status		
0	747 (80.1%)	382 (81.6%)
1	185 (19.8%)	85 (18.2%)
>1	0 (0.0%)	0 (0.0%)
Missing	1 (0.1%)	1 (0.2%)
ITT: Intent to Treat; BTA: Bone targeting agents; PSA: Prostate Specific Antigen Patients with soft tissue pelvic disease were eligible if lesions do not qualify as target lesions (e.g., lymph nodes below aortic bifurcation are permissible if the short axis of the largest lymph node is <15 mm)		

Study results

Xtandi demonstrated a statistically significant 71% reduction in relative risk of radiographic progression or death as compared to placebo [HR = 0.29 (95% CI: 0.24, 0.35), $p < 0.0001$]. Median MFS was 36.6 months (95% CI: 33.1, NR) in the Xtandi arm versus 14.7 months (95% CI: 14.2, 15.0) in the placebo arm (Table 10, Figure 3). Consistent MFS results were observed across all pre-specified patient subgroups (Figure 4).

In addition to the primary efficacy endpoint, statistically significant improvements were shown for secondary endpoints time to PSA progression, and time to first use of new antineoplastic therapy (Table 10).

The median follow-up time for all patients based on reverse Kaplan-Meier estimation was 18.5 months in the enzalutamide group and 15.1 months in the placebo group. At the time of the analysis of MFS, overall survival (OS) results were not mature (28% of required number of events) and the p-value did not reach the prespecified statistical significance level.

Table 10: Summary of efficacy results in the PROSPER study (intent-to-treat analysis)		
	Xtandi (N = 933)	Placebo (N = 468)
Primary Endpoint		
Metastasis-free survival		
Number of Events (%)	219 (23.5)	228 (48.7)
Median, months (95% CI) ^a	36.6 (33.1, NR)	14.7 (14.2, 15.0)
Hazard Ratio (95% CI) ^b	0.29 (0.24, 0.35)	
P-value ^c	p < 0.0001	
Key Secondary Efficacy Endpoints		
Time to PSA progression		
Number of Events (%)	208 (22.3)	324 (69.2)
Median, months (95% CI) ^a	37.2 (33.1, NR)	3.9 (3.8, 4.0)
Hazard Ratio (95% CI) ^b	0.07 (0.05, 0.08)	
P-value ^c	p < 0.0001	
Time to first use of new antineoplastic therapy		
Number of Events (%)	142 (15.2)	226 (48.3)
Median, months (95% CI) ^a	39.6 (37.7, NR)	17.7 (16.2, 19.7)
Hazard Ratio (95% CI) ^b	0.21 (0.17, 0.26)	
P-value ^c	p < 0.0001	

NR = Not reached.

- a. Based on Kaplan-Meier estimates.
- b. HR is based on a Cox regression model (with treatment as the only covariate) stratified by PSA doubling time and prior or concurrent use of a bone-targeting agent. The HR is relative to placebo with < 1 favouring enzalutamide.
- c. P-value is based on a stratified log-rank test by PSA doubling time (< 6 months, ≥ 6 months) and prior or concurrent use of a bone targeting agent (yes, no).

Figure 3: Kaplan-Meier Curves of metastasis-free survival in the PROSPER study (intent-to-treat analysis)

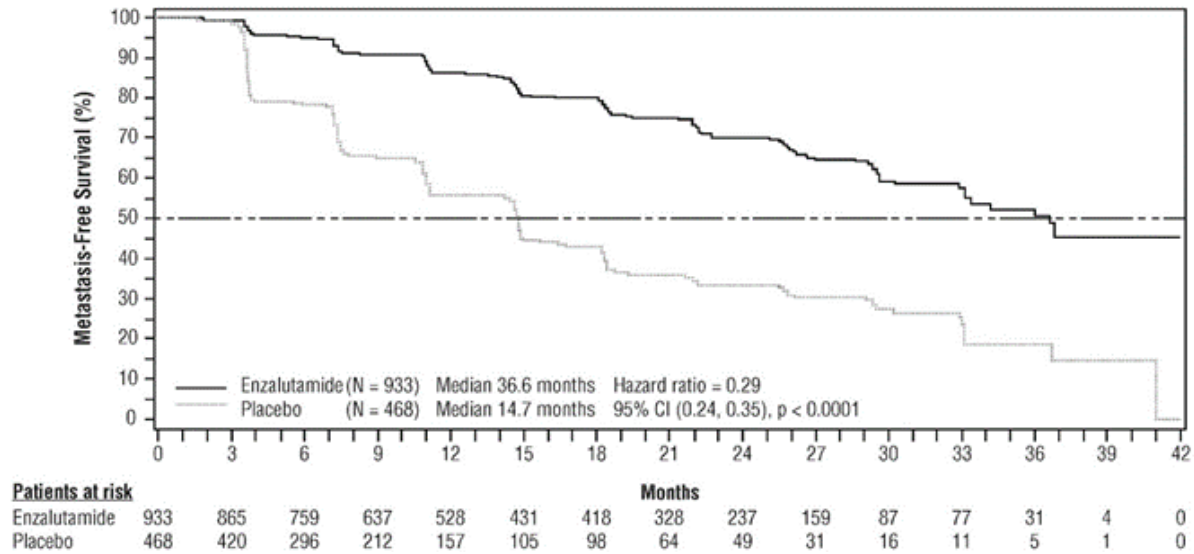
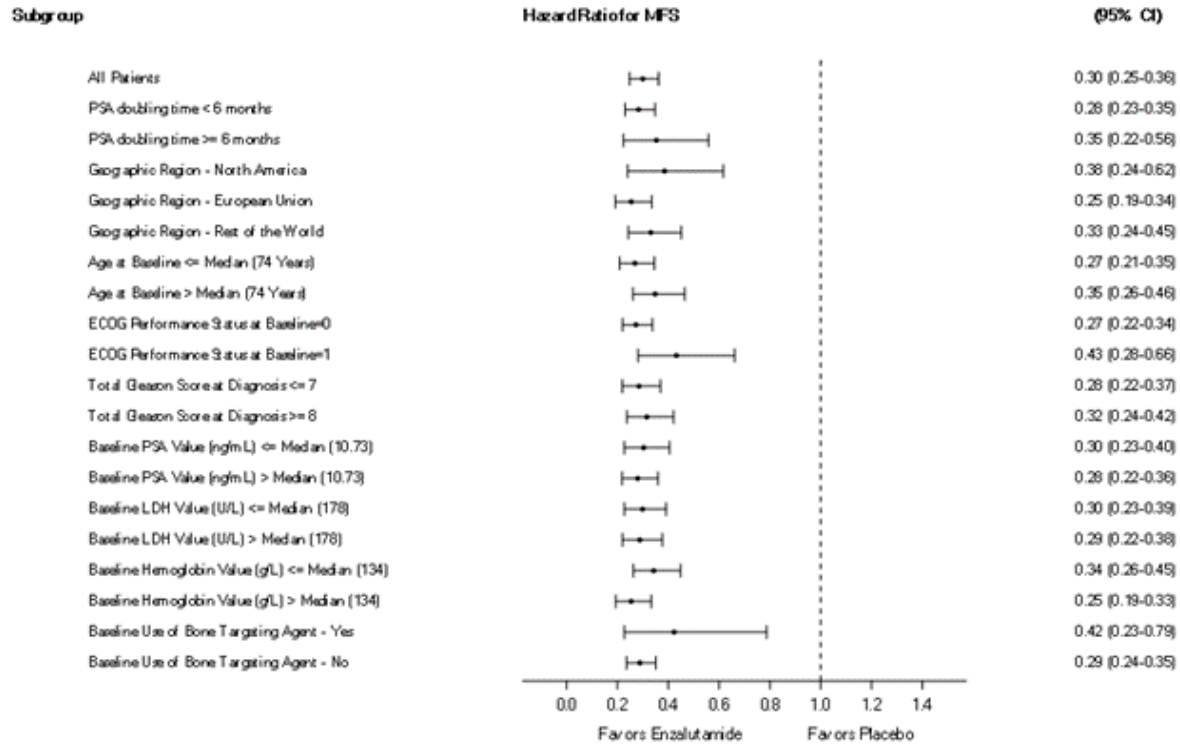

Figure 4: Forest Plot of MFS in Study MDV3100-14 - Subgroup Analysis (ITT Population)



All patients randomly assigned to study treatment and based on randomized treatment assignment regardless of whether or not treatment was administered (ITT Population).

Hazard ratios for all patients and for all other subgroups were based on an unstratified Cox regression model with treatment as the only covariate.

ECOG: Eastern Cooperative Oncology Group; ITT: intent-to-treat; LDH: lactate dehydrogenase; MFS: metastasis-free survival; PSA: prostate-specific antigen.

Chemotherapy-naïve mCRPC that Progressed on Androgen Deprivation Therapy (PREVAIL)

Study demographics and trial design

In the PREVAIL study, a total of 1717 patients with asymptomatic or mildly symptomatic metastatic castration-resistant prostate cancer who had not received prior chemotherapy were randomized 1:1 to receive either Xtandi orally at a dose of 160 mg once daily (N = 872) or placebo orally once daily (N = 845). Patients were allowed, but not required, to continue or initiate corticosteroids (maximum daily dose allowed was 10 mg prednisone or equivalent). Patients with visceral disease, patients with a history of mild to moderate heart failure (NYHA Class 1 or 2), and patients taking medications associated with lowering the seizure threshold were allowed. Patients with a previous history of seizure or a condition that might predispose to seizure and patients with moderate or severe pain from prostate cancer were excluded. Study treatment continued until disease progression (evidence of radiographic progression, a skeletal-related event, or clinical progression) and the initiation of either a cytotoxic chemotherapy or an investigational agent, or until unacceptable toxicity or withdrawal.

Changes in PSA serum concentration independently do not always predict clinical benefit. PSA rise without evidence of confirmed radiographic progression or a skeletal-related event was strongly discouraged as a criterion to start a new systemic antineoplastic therapy during the first 12 weeks of therapy and was discouraged as a criterion to start a new systemic antineoplastic therapy throughout the study.

Co-primary efficacy endpoints were overall survival and radiographic progression-free survival (rPFS). In addition to the co-primary endpoints, benefit was also assessed using secondary endpoints as follows: time to initiation of cytotoxic chemotherapy, best overall soft tissue response, time to first skeletal-related event, PSA response ($\geq 50\%$ decrease from baseline), and time to PSA progression.

Radiographic progression was assessed with the use of sequential imaging studies as defined by Prostate Cancer Clinical Trials Working Group 2 (PCWG2) criteria (for bone lesions) and/or Response Evaluation Criteria in Solid Tumors (RECIST v 1.1) criteria (for soft tissue lesions). Analysis of rPFS utilized centrally-reviewed radiographic assessment of progression.

Patient demographics and baseline disease characteristics were balanced between the treatment arms (see Table 11). Fifty-four percent of patients had radiographic evidence of disease progression and 43% had PSA-only progression. Approximately 45% of patients had measurable soft tissue disease at study entry, and 12% of patients had visceral (lung and/or liver) metastases.

Table 11: PREVAIL Key Demographics and Baseline Disease Characteristics		
Baseline Characteristic	Xtandi (N = 872)	Placebo (N = 845)
Age (years)		
Mean (SD)	71.3 (8.5%)	71.2 (8.42%)
Min, Max	43.0, 93.0	42.0, 93.0
Race		
White	669 (76.7%)	655 (77.5%)
Other, multiple, or unknown	95 (10.9%)	94 (11.1%)
Asian	85 (9.7%)	82 (9.7%)
Black	21 (2.4%)	13 (1.5%)
American Indian or Alaska Native	1 (0.1%)	0 (0.0%)
Native Hawaiian or other Pacific Islander	1 (0.1%)	1 (0.1%)
Time from initial diagnosis or first treatment of prostate cancer to randomization		
N	872	844
Median (months)	62.7	64.6
Baseline ECOG performance status (n [%])		
0	584 (67.0%)	585 (69.2%)
1	288 (33.0%)	260 (30.8%)
Distribution of disease at screening ^a		
Bone	741 (85.0%)	690 (81.7%)
Lymph node	437 (50.1%)	434 (51.4%)
Visceral disease (lung or liver)	98 (11.2%)	106 (12.5%)
Other soft tissue	113 (13.0%)	105 (12.4%)
Baseline mean pain score ^b		
N	859	840
0 to 1	569 (66.2%)	567 (67.5%)
2 to 3	275 (32.0%)	262 (31.2%)
> 3	15 (1.7%)	11 (1.3%)
Number of bone metastases at screening		
0	131 (15.0%)	155 (18.3%)
1	97 (11.1%)	85 (10.1%)
2 to 4	213 (24.4%)	186 (22.0%)
5 to 9	146 (16.7%)	147 (17.4%)
10 to 20	140 (16.1%)	122 (14.4%)
> 20	145 (16.6%)	150 (17.8%)
Baseline serum PSA (ng/mL)		
N	872	844
Mean (SD)	140.7 (284.22)	137.9 (298.61)
Min, max	0.1, 3182.0	0.3, 3637.0
Baseline use of corticosteroids (> 7 days) (n [%]) ^c		
	35 (4.0%)	36 (4.3%)
<p>a. Patients can be summarized for more than 1 category but are counted only once for each category.</p> <p>b. Protocol defined by a score of < 4 on question 3 on the Brief Pain Inventory Short Form (BPI) [worst prostate cancer-related pain over past 24 hours] assessed both at screening and again before randomization at baseline visit.</p> <p>c. Includes all oral steroid use on the date of first dose of study drug. Excludes steroids taken for indications not associated with prostate cancer and continuous steroids taken for less than 7 days. ECOG, Eastern Cooperative Oncology Group; PSA, prostate-specific antigen.</p>		

Study results

At the pre-specified interim analysis for overall survival, treatment with Xtandi demonstrated a statistically significant improvement in overall survival compared to treatment with placebo

with a 29.4% reduction in risk of death [HR=0.706, (95% CI: 0.596; 0.837), $p < 0.0001$]. At the interim analysis, 27.6% (241 of 872) of patients treated with Xtandi, compared with 35.4% (299 of 845) of patients treated with placebo, had died. Estimated median overall survival was

32.4 months (95% CI: 30.1, not reached) in the Xtandi-treated patients and was 30.2 months (95% CI: 28.0, not reached) in the placebo-treated patients (Table 12). In addition, 40.4% of Xtandi-treated patients and 70.5% of placebo-treated patients received subsequent therapies with a demonstrated survival benefit. Median follow-up time based on reverse Kaplan-Meier estimates were 22.2 months for Xtandi-treated patients and 22.4 months for placebo-treated patients.

An updated survival analysis (June 01, 2014) was conducted when 784 deaths were observed. The median follow-up time based on reverse Kaplan-Meier estimates was approximately 31 months. Results from this analysis were consistent with those from the pre-specified interim analysis (Table 12, Figure 5). At the updated analysis, 52.4% of Xtandi-treated and 81.1% of placebo-treated patients had received subsequent therapies with a demonstrated survival benefit.

Table 12: PREVAIL Duration of Overall Survival – Co-primary Analysis (ITT Population)		
Parameter	Xtandi (N = 872)	Placebo (N = 845)
Pre-Specified Interim Analysis^a		
Deaths	241 (27.6%)	299 (35.4%)
Median survival, months (95% CI)	32.4 (30.1, NYR)	30.2 (28.0, NYR)
P-value ^{6b}	< 0.0001	
Hazard ratio (95% CI) ^{6c}	0.706 (0.596, 0.837)	
Updated Survival Analysis^a		
Deaths	368 (42.2%)	416 (49.2%)
Median survival, months (95% CI)	35.3 (32.2, NYR)	31.3 (28.8, 34.2)
P-value (nominal)	0.0002	
Hazard ratio (95% CI) ^{6c}	0.767 (0.666, 0.882)	

- a. Cut-off dates: September 16, 2013 (interim analysis) and June 01, 2014 (updated analysis)
- b. P-value is derived from unstratified log-rank test.
- c. The hazard ratio is based on an unstratified Cox regression model (with treatment as the only covariate) and is relative to placebo with < 1 favouring Xtandi. ITT, intent-to-treat; NYR, not yet reached.

The treatment effect was apparent after the first three months of treatment and maintained through the follow-up period (Figure 5). Subgroup survival analysis showed a consistent survival benefit for treatment with Xtandi (Figure 6).

Figure 5: Kaplan-Meier Overall Survival Curves of Patients Treated with Either Xtandi or Placebo in the PREVAIL Study (Intent-to-Treat Analysis*)

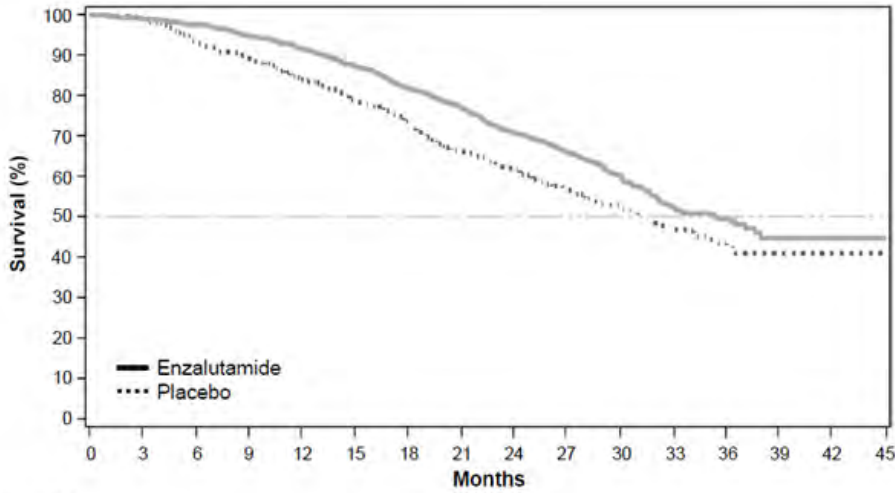

Patients at risk		0	3	6	9	12	15	18	21	24	27	30	33	36	39	42	45
Enzalutamide		872	863	850	824	798	758	710	665	597	441	289	174	86	21	2	0
Placebo		845	835	782	745	702	657	612	551	504	365	254	153	72	16	2	0

* updated analysis (June 01, 2014)

Figure 6: Overall Survival Analysis by Subgroup: Hazard Ratio and 95% Confidence Interval in the PREVAIL Study (Intent-to-Treat Analysis*)

Subgroup	Number of Patients Enzalutamide/Placebo	Hazard Ratio for Death (95% CI)
All Patients	872/845	0.77 (0.67, 0.88)
Age < 75	555/553	0.87 (0.72, 1.04)
Age ≥ 75	317/292	0.62 (0.50, 0.78)
ECOG Performance Status = 0	584/585	0.80 (0.67, 0.96)
ECOG Performance Status = 1	288/260	0.68 (0.54, 0.86)
Baseline PSA Value (ng/mL) ≤ Median (49.60)	420/440	0.86 (0.68, 1.09)
Baseline PSA Value (ng/mL) > Median (49.60)	452/404	0.65 (0.55, 0.77)
Baseline LDH Value (U/L) ≤ Median (185)	443/423	0.74 (0.60, 0.93)
Baseline LDH Value (U/L) > Median (185)	428/421	0.80 (0.67, 0.96)
Total Gleason Score at Diagnosis ≤ 7	414/385	0.75 (0.61, 0.93)
Total Gleason Score at Diagnosis ≥ 8	424/423	0.80 (0.66, 0.98)
Visceral Lung and/or Liver Disease at Screening – Yes	98/106	0.69 (0.48, 1.01)
Visceral Lung and/or Liver Disease at Screening – No	774/739	0.78 (0.67, 0.91)

0.0 0.5 1.0 1.5 2.0
Favors Enzalutamide Favors Placebo

* updated analysis (June 01, 2014))

At the pre-specified rPFS analysis, a statistically significant improvement was demonstrated between the treatment groups with an 81.4% reduction in risk of radiographic progression or

death [HR = 0.186 (95% CI: 0.149, 0.231), $p < 0.0001$]. One hundred and eighteen (14%) Xtandi-treated patients and 321 (40%) of placebo-treated patients had an event. The median rPFS was not reached (95% CI: 13.8, not reached) in the Xtandi-treated group and was 3.9 months (95% CI: 3.7, 5.4) in the placebo-treated group (Figure 7, Table 13). Consistent rPFS benefit was observed across all pre-specified patient subgroups (Figure 8). Median follow-up time based on reverse Kaplan-Meier estimates were 5.4 months for Xtandi-treated patients and 3.6 months for placebo-treated patients.

Table 13: PREVAIL, Duration of Radiographic Progression-Free Survival – Co-primary Analysis Based on Independent Central Review (ITT Population)

Radiographic Progression-Free Survival Follow-Up	Xtandi (N = 832)	Placebo (N = 801)
rPFS Events ^a	118 (14.2%)	321 (40.1%)
Duration of rPFS (months) ^{b,c}		
Median duration of rPFS (months) ^{b,c} (95% CI)	NYR (13.8, NYR)	3.9 (3.7, 5.4)
P-value (unstratified)	< 0.0001	
Hazard ratio (95% CI) ^d	0.186 (0.149, 0.231)	

- a. Based on the earliest contributing event (radiographic progression or death due to any cause within 168 days after treatment discontinuation).
- b. Patients who were not known to have had an rPFS event at the time of analysis data cutoff are censored at date of last assessment showing no objective evidence of radiographic progression prior to scan modality change, new antineoplastic treatment, initiation of radiation therapy for prostate cancer, skeletal-related event, treatment discontinuation, and 2 or more consecutive missed tumour assessments.
- c. Based on Kaplan-Meier estimates.
- d. The hazard ratio is based on a Cox regression model (with treatment as the only covariate) and is relative to placebo with < 1 favouring Xtandi. ITT, intent-to-treat; NYR, not yet reached; rPFS, radiographic progression-free survival.

Figure 7: Kaplan-Meier Curves of Radiographic Progression-Free Survival in Patients Treated with Either Xtandi or Placebo in the PREVAIL Study (Intent-to-Treat Analysis*)

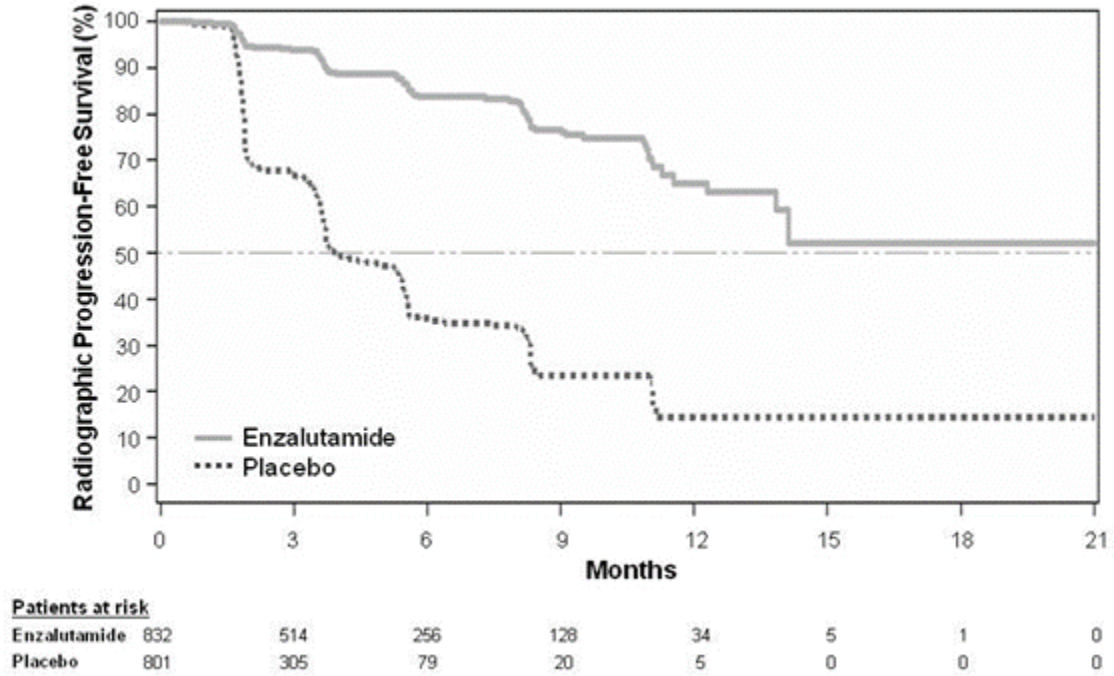

* At the time of the primary analysis there were 1633 patients randomized.

Figure 8: Radiographic Progression-Free Survival by Subgroup: Hazard Ratio and 95% Confidence Interval in the PREVAIL Study (Intent-to-Treat Analysis)

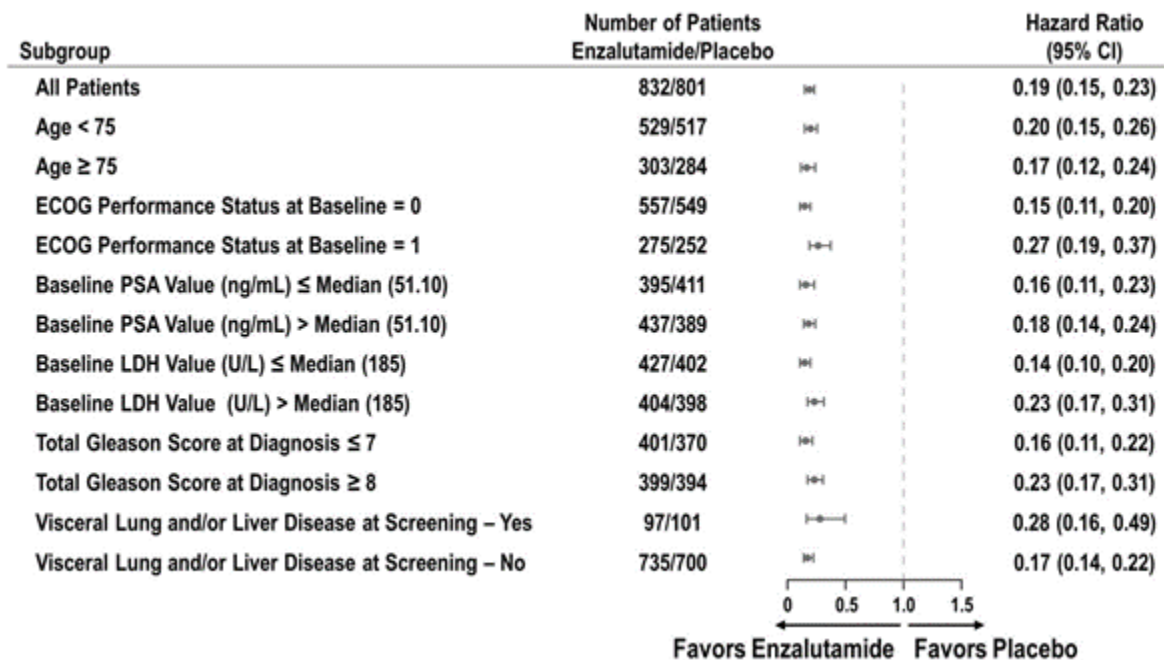

In addition to the co-primary efficacy endpoints, statistically significant improvements were also demonstrated in prospectively defined secondary endpoints, see Table 14.

Endpoint	Xtandi	Placebo	Hazard Ratio [95% CI]	P-Value
Secondary Efficacy Endpoints				
Time To Initiation Of Cytotoxic Chemotherapy ^a	28.0 months	10.8 months	0.349 (0.303, 0.403)	< 0.0001
Best Overall Soft Tissue Response	58.8%	5.0%	53.85% (48.53, 59.17%)	< 0.0001
Complete response	19.7%	1.0%		
Partial response	39.1%	3.9%		
Time to First Skeletal-Related Event (median) ^{a,b}	31.1 months	31.3 months	0.718 (0.610, 0.844)	< 0.0001
Time to PSA Progression ^{a,c}	11.2 months	2.8 months	0.169 (0.147, 0.195)	< 0.0001
PSA Response Rate ≥ 50% Decrease	78.0%	3.5%	N/A	< 0.0001

a. Based on Kaplan-Meier estimates.

b. Skeletal-related event was defined as radiation therapy or surgery to bone for prostate cancer, pathological bone fracture, spinal cord compression, or change of antineoplastic therapy to treat bone pain from prostate cancer.

c. Based on PSA progression compliant with Prostate Cancer Clinical Trials Working Group 2 criteria.

Best overall soft tissue response was analyzed for the ITT population with measurable soft tissue disease at baseline, defined by the presence of at least 1 target lesion according to RECIST v 1.1 as assessed by the investigator. Response categories are based on target, non-target, and new lesions. Confirmation of response was not required. The trial used the same modality of imaging (CT or MRI) throughout the trial for each institution.

PSA response $\geq 50\%$ decreased from baseline was evaluated in 854 patients (97.9%) in the Xtandi treatment group and 777 patients (92.0%) in the placebo treatment group who had both baseline and at least 1 post-baseline PSA assessment during the study (ITT evaluable population). Confirmation required a subsequent assessment that was consecutive and conducted at least 3 weeks later.

mCRPC Patients with Prior Docetaxel Treatment (AFFIRM)

Study demographics and trial design

In the AFFIRM study, a total of 1199 patients with metastatic castration-resistant prostate cancer who had previously received docetaxel were randomized 2:1 to receive either Xtandi orally at a dose of 160 mg once daily (N = 800) or placebo once daily (N = 399). Patients were allowed, but not required, to continue or initiate corticosteroids (47.8% vs. 45.6% were administered corticosteroids in Xtandi and placebo arms, respectively). In addition, 51.0% vs. 49.6% of patients in the Xtandi and placebo arms, respectively, were using bisphosphonates at baseline.

Patients were excluded if having a history of seizure, including any febrile seizure, loss of consciousness, or transient ischemic attack within 12 months of enrollment (Day 1 visit), or any condition that may pre-dispose to seizure (e.g. prior stroke, brain arteriovenous malformation, head trauma with loss of consciousness requiring hospitalization). Patients were also excluded if they had clinically significant cardiovascular disease, significant renal impairment, hepatic impairment, or histologically or cytologically confirmed adenocarcinoma of the prostate without neuroendocrine differentiation or small cell features were excluded from the study.

Patients randomized to either arm were to continue treatment until either:

1. Disease progression (defined as radiographic progression or the occurrence of a skeletal-related event) and initiation of a new systemic antineoplastic treatment
2. Death
3. Unacceptable toxicity
4. Withdrawal

Increases in PSA, especially during the first 12 weeks of therapy, were not considered disease progression.

The primary efficacy endpoint for the AFFIRM study was overall survival defined as time from randomization to death from any cause.

The following key secondary efficacy endpoints were evaluated:

- Radiographic progression-free survival, defined as the time to the earliest objective evidence of radiographic progression or death due to any cause. Radiographic disease progression is defined by RECIST v 1.1 for soft tissue disease, or the appearance of two or more new lesions on bone scan, as per PCWG2 criteria, with a confirmatory scan 6 or more weeks only after the first assessment (13 weeks after initial dose).
- Time to PSA progression, defined as the time from randomization to PSA progression. PSA progression was assessed for each patient in the study using the Prostate Cancer Clinical Trials Working Group 2 (PCWG2) criteria. PSA progression could only be declared on or after the Week 13 assessment and required a confirmation that was consecutive and conducted at least 3 weeks later.
- Time to first skeletal-related event, where skeletal-related event was defined as radiation therapy or surgery to bone, pathologic bone fracture, spinal cord compression, or change of antineoplastic therapy to treat bone pain.

Additional efficacy endpoints included PSA response rate ($\geq 50\%$ or $\geq 90\%$ reduction from baseline), and the response rate for quality of life as measured by Functional Assessment of Cancer Therapy – Prostate [FACT-P]. Patients were defined as having a positive quality of life response if they had a 10-point improvement in their global FACT-P score, compared with baseline, on 2 consecutive measurements obtained at least 3 weeks apart.

The patient demographics and baseline disease characteristics were balanced between the treatment arms (see Table 15).

	Xtandi (160 mg/day) N = 800	Placebo N = 399
Age (years)		
Mean (SD)	68.8 (7.96)	68.6 (8.39)
Min, Max	41.0, 92.0	49.0, 89.0
Race		
Asian	5 (0.6%)	8 (2.0%)
Black	27 (3.4%)	20 (5.0%)
White	745 (93.1%)	366 (91.7%)
Other	23 (2.9%)	5 (1.3%)
Baseline ECOG Performance Status		
0	298 (37.3%)	156 (39.1%)
1	432 (54.0%)	211 (52.9%)
2	70 (8.8%)	32 (8.0%)
Baseline PSA (ng/mL)		
Mean (SD)	415.6 (930.76)	389.4 (1105.72)

Median	107.7	128.3
Min, Max	0.2, 11794.1	0.0, 19000.0
Average Pain Score as Assessed by Brief Pain Inventory ^a		
< 4	574 (71.8%)	284 (71.2%)
≥ 4	226 (28.3%)	115 (28.8%)
Type of Disease Progression at Study Entry		
PSA progression only	326 (40.8%)	164 (41.2%)
Radiographic progression ^b	470 (58.8%)	234 (58.8%)
Missing	4	1
Distribution of Disease at Screening		
Bone	730 (92.2%)	364 (91.5%)
Lymph node	442 (55.8%)	219 (55.0%)
Visceral liver	92 (11.6%)	34 (8.5%)
Visceral lung	122 (15.4%)	59 (14.8%)
Other soft tissue	147 (18.6%)	70 (17.6%)
Missing	8	1

- a. Mean of patient's reported worst pain over the previous 24 hours calculated for seven days prior to randomization. Randomization was stratified by baseline ECOG performance status score (0–1 vs. 2) and mean Brief Pain Inventory – Short Form Question #3 score averaged over the 7 days prior to randomization;
- b. Bone and or soft tissue.

Study results

The pre-specified interim analysis was conducted after 520 deaths were observed. A statistically significant 4.8 month improvement in median overall survival was observed with treatment with Xtandi versus placebo (18.4 months and 13.6 months respectively), (Table 16 and Figure 9). The stratified hazard ratio for death for Xtandi-treated patients was 0.631 (95% CI: 0.529, 0.752; $p < 0.0001$), a 37% reduction in the risk of patient death.

At all evaluation time points after the initial few months of treatment, a higher proportion of patients treated with Xtandi remained alive, compared to those treated with placebo (Figure 9). The median duration of follow-up was 14.4 months.

Table 16: Overall Survival of Patients Treated with Either Xtandi or Placebo in the AFFIRM Study (Intent-to-Treat Analysis)		
Parameter	Xtandi (N = 800)	Placebo (N = 399)
Deaths (%)	308 (38.5%)	212 (53.1%)
Median survival (months) (95% CI)	18.4 (17.3, NR)	13.6 (11.3, 15.8)
P-value ^a	< 0.0001	
Hazard ratio (95% CI) ^b	0.631 (0.529, 0.752)	

- a. P-value is derived from a log-rank test stratified by ECOG performance status score (0-1 vs. 2) and mean pain score (< 4 vs. ≥ 4).
- b. Hazard Ratio is derived from a stratified proportional hazards model. Hazard ratio < 1 favours Xtandi. NR: not reached.

Figure 9: Kaplan-Meier Overall Survival Curves of Patients Treated with Either Xtandi or Placebo in the AFFIRM Study (Intent-to-Treat Analysis)

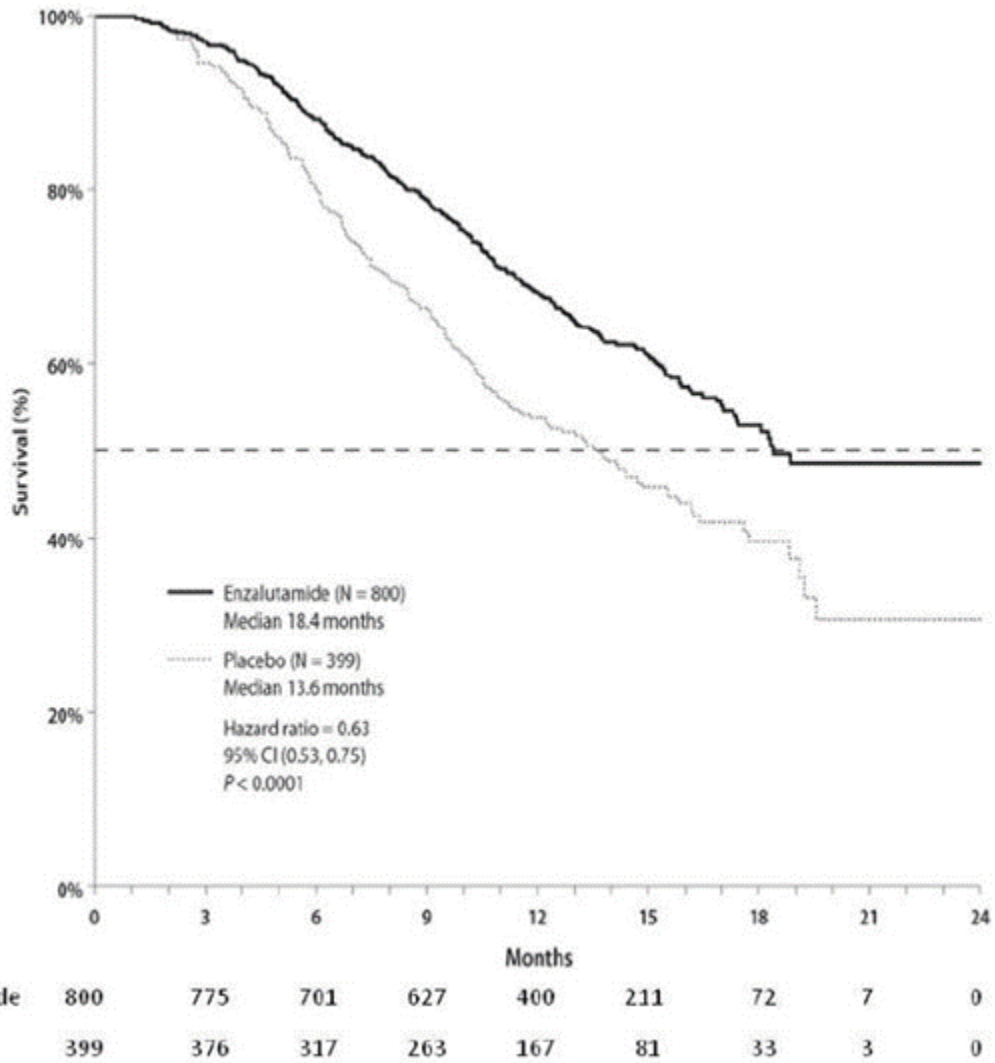

The median duration of therapy on Xtandi was 8.3 months vs. 3.0 months for placebo.

Subgroup survival analysis demonstrated a consistent favourable survival benefit for treatment with Xtandi (see Figure 10).

Figure 10: Overall Survival by Subgroup – Hazard Ratio and 95% Confidence Interval in the AFFIRM Study

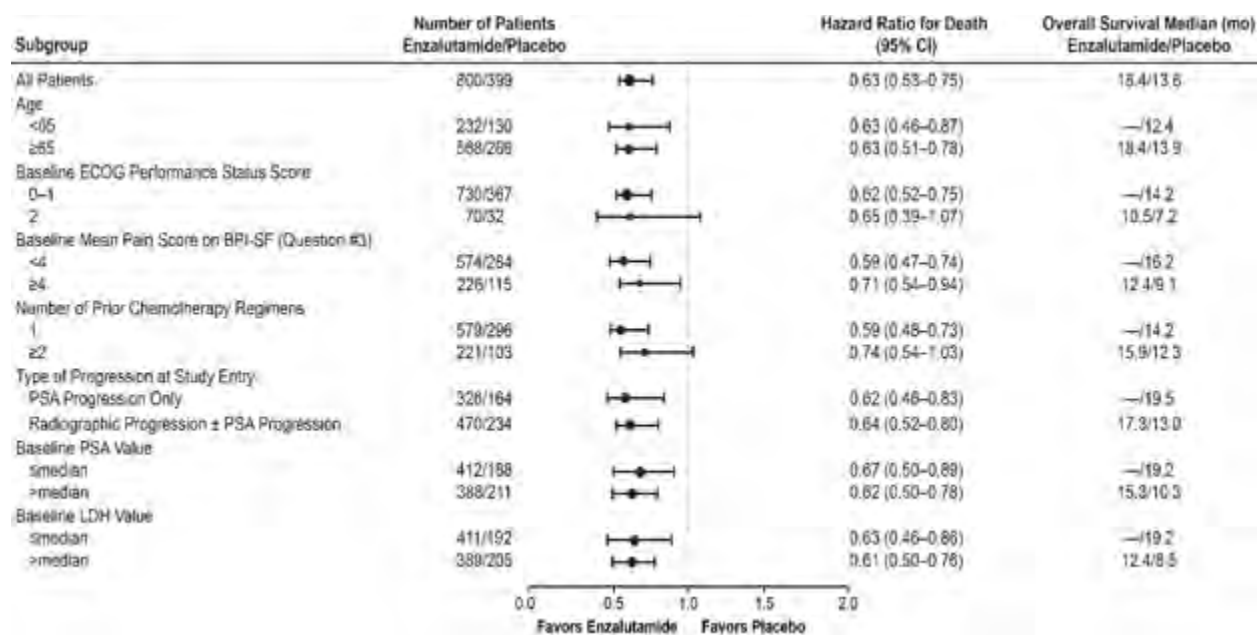

The benefit observed for Xtandi in overall survival was supported by significant improvements in all secondary endpoints (see Table 17).

Endpoint	Xtandi	Placebo	Hazard Ratio [95% CI]	P-Value
Key Secondary Efficacy Endpoints				
Time to PSA Progression (median)	8.3 months	3.0 months	0.248 [0.204, 0.303]	< 0.0001
Radiographic Progression-Free Survival (median)	8.3 months	2.9 months	0.404 [0.350, 0.466]	< 0.0001
Time to First Skeletal-Related Event (median)	16.7 months	13.3 months	0.688 [0.566, 0.835]	0.0001
Other Secondary Efficacy Endpoints^a				
FACT-P Response Rate ^b	43.2%	18.3%	NA	< 0.0001
PSA Response Rate			NA	
≥ 50% Decrease	54.0%	1.5%		< 0.0001
≥ 90% Decrease	24.8%	0.9%		< 0.0001

a. No corrections for multiplicity were made for these efficacy endpoints.

b. The evaluable population consists of 85.9% (651/758) of patients in the Xtandi group with a Global FACT-P score at baseline and 66.8% (257/385) of patients in the placebo group with a Global FACT-P score at baseline. The disparity in the evaluable population for FACT-P analysis was due to a higher number of placebo patients who discontinued study treatment early due to disease progression.

DETAILED PHARMACOLOGY

Animal Pharmacology

Decreased activity, tremor and/or convulsions were observed in mice following a single oral dose of enzalutamide ≥ 400 mg/kg. Enzalutamide treatment was also associated with convulsions in mice upon oral dosing of ≥ 200 mg/kg for 7 days. A low incidence of convulsions was observed in the pivotal repeat dose toxicity studies in rats and dogs (1 individual animal in the highest dose group per study). *In vitro*, enzalutamide and its metabolites bind and inhibit the GABA-gated chloride channel, an off-target mechanism associated with the onset of seizure in animals. Enzalutamide and M2 were also found to cross the blood-brain barrier in rodents.

	Studies	Observation
<i>In vitro</i>	Chloride channel binding	Enzalutamide binds to the GABA-gated chloride channel: IC ₅₀ = 2.6 μ M (1.2 μ g/mL) K _i = 2.1 μ M (1.0 μ g/mL)
		M2 binds to the GABA-gated chloride channel: IC ₅₀ = 7.1 μ M (3.2 μ g/mL) K _i = 5.9 μ M (2.7 μ g/mL)
	Inhibition of GABA-gated chloride channel activity in whole cells	Enzalutamide inhibits the GABA-gated chloride channel IC ₅₀ = 3.0 μ M (1.4 μ g/mL)
		M2 inhibits the GABA-gated chloride channel IC ₅₀ = 2.3 μ M (1.04 μ g/mL)
<i>In vivo</i>	Brain penetration studies in rodents	Enzalutamide and M2 crossed the blood-brain barrier in rats and mice. Based on the brain-to-plasma ratios in rats, enzalutamide and M2 concentrations in brain are approximately the same as those in the plasma.
	2-week oral gavage bridging toxicity study in rats	Enzalutamide treatment was associated with a convulsion in a single rat at a dose of 100 mg/kg.
	Single-dose study in mice	Enzalutamide treatment was associated with convulsions in mice at a dose ≥ 400 mg/kg
	Repeat-dose oral toxicity study in mice	Enzalutamide treatment was associated with a convulsion in a single female mouse (1/5 per group) at a dose of 300 mg/kg on Day 2
	Convulsion model in mice	Enzalutamide treatment was associated with a dose-dependent incidence of convulsions in mice at doses ≥ 200 mg/kg
	4-week dog toxicity study	Enzalutamide treatment in 28-day dog toxicity study was associated with a single convulsion on Day 28 in a dog receiving 60 mg/kg/day.
	39-week dog toxicity study	Enzalutamide treatment was associated with convulsions on Day 13 in one dog receiving 45 mg/kg/day. Dosing (45 mg/kg/day) in this animal was re-started at day 17; no convulsions occurred for the remainder of the study duration.

IC₅₀, concentration required for 50% inhibition; GABA, gamma aminobutyric acid.

Nonclinical Pharmacokinetics

The absorption, distribution, metabolism and excretion of [¹⁴C]-enzalutamide was studied in rats and dogs. Enzalutamide was extensively metabolized in these species via the same Phase I reactions observed in humans, mainly via demethylation, oxidation and hydrolysis. The two major metabolites in human plasma also circulate in rat and dog plasma; however, the exposure

(C_{max} and AUC_{24h}) of M2 in these species was ≤ 15% that of humans. In rodents, M2 is hydrolyzed to M1 by plasma esterases. Enzalutamide was eliminated mainly as metabolites in the feces of rats and in the urine of dogs. M1 was the major metabolite in excreta. Phase I metabolites were the precursors to Phase II products, such as glutathione, glucuronide, and taurine conjugates that were observed in animal bile. Acyl glucuronides and their rearrangement isomers have been detected in bile of both rats and dogs; whether enzalutamide is metabolized to form acyl glucuronides in humans is not known.

Tissue distribution studies in rodents have shown that enzalutamide and M2 readily cross the blood-brain barrier, whereas M1 poorly penetrates the brain.

Studies in lactating rats have shown that enzalutamide and/or its metabolites are secreted in rat milk. After oral administration of radiolabeled ¹⁴C-enzalutamide to lactating rats at a dose of 30 mg/kg, the maximum radioactivity in the milk was reached 4 hours after administration and was up to 3.54-fold higher than that in the maternal plasma. Study results also have shown that enzalutamide and/or its metabolites are transferred to infant rat tissues via milk and subsequently eliminated.

Studies in pregnant rats have shown that enzalutamide and/or its metabolites are transferred to fetuses. After oral administration of radiolabeled ¹⁴C-enzalutamide to rats on day 14 of pregnancy at a dose of 30 mg/kg, the maximum radioactivity in the fetus was reached 4 hours after administration and was lower than that in the maternal plasma with a tissue/plasma ratio of 0.27. The radioactivity in the fetus decreased to 0.08 times the maximum concentration at 72 hours after administration.

Human Pharmacology - In Vitro

A summary of the *in vitro* evaluations with human biomaterials and enzalutamide and major human metabolites M1 and M2 are presented in the table below, along with the primary study conclusions.

Table 19: Overview of <i>In Vitro</i> Evaluations of Enzalutamide and Metabolites	
Type of Study	Results and Conclusion
Caco-2 permeability	Mean permeability flux values for enzalutamide in the absorptive apical-to-basolateral (A→B) direction were ≥ 31 × 10 ⁻⁶ cm/s at all concentrations, more than twice the apparent permeability of propranolol. Bidirectional permeability indicated that transport is passive. Enzalutamide is a high permeability compound that crosses Caco-2 cell monolayers by passive diffusion
Protein binding in human plasma	Enzalutamide, M1, and M2 are highly protein bound in plasma. Enzalutamide: 97%–98%. M1: 98%, M2: 95%
Protein binding in solutions	Albumin is the main binding protein in human plasma. Albumin: 97%, High density lipoprotein: 75% to 77%, Low density lipoprotein: 70% to 75%, α ₁ -acid glycoprotein: 44% to 52% γ-globulin: 10% to 19%
Red blood cell distribution	Enzalutamide was preferentially retained in the plasma component of blood. Whole blood-to-plasma ¹⁴ C-AUC _{inf} ratio: 0.55

Table 19: Overview of <i>In Vitro</i> Evaluations of Enzalutamide and Metabolites	
Type of Study	Results and Conclusion
Metabolism with human recombinant CYP enzymes ^a	Mean recovery of enzalutamide after a 2 hour incubation with CYP2C8, CYP3A4, and CYP3A5 ranged from 67.0% to 81.8% suggesting slow metabolism. CYP2C8, CYP3A4, and CYP3A5 may play a role in the metabolism of enzalutamide.
Metabolism with human liver microsomes and human plasma	Incubation of enzalutamide (4.64 µg/mL) with microsomes produced metabolites M2 and a N-hydroxymethyl derivative of enzalutamide (M6); whereas, no metabolites were observed in enzalutamide incubations with human plasma or phosphate buffer. Incubation with M6 (10 µM) with microsomes, human plasma, or phosphate buffer resulted in M2 formation. Enzalutamide is metabolized to M2 and M6 in the presence of human microsomes, and M6 degrades to M2 in a reaction that does not require metabolic enzymes.
Induction of CYP enzymes in human primary hepatocytes	Enzalutamide or M2 increased mRNA expression and enzyme activity of CYP2B6, CYP2C8, CYP2C9, CYP2C19, and CYP3A4. M1 increased mRNA expression of CYP2C8 but did not increase enzyme activity. Enzalutamide, M1 or M2 increased mRNA expression of UGT1A1 and UGT1A4. Enzalutamide, M1 or M2 did not increase mRNA expression of CYP1A2. Enzalutamide has the potential to induce CYP2B6, CYP2C8, CYP2C9, CYP2C19, CYP3A4, UGT1A1 and UGT1A4 in the clinical setting.
Inhibition of CYP enzymes in human liver microsomes	Enzalutamide, M1, and/or M2 are inhibitors of CYP2C8 and CYP2C19 with lesser inhibitory effects on CYP2B6 and CYP2C9. Enzalutamide showed time-dependent inhibition of CYP1A2 with a pattern suggesting that a metabolite formed <i>in vitro</i> (other than M1 or M2) may be a more potent inhibitor of this enzyme than enzalutamide itself. M2 showed weak time-dependent inhibition of CYP3A4/5. Enzalutamide has the potential to inhibit CYP1A2, CYP2B6, CYP2C8, CYP2C9, CYP2C19, and CYP3A4/5 in the clinical setting.
P-glycoprotein (MDR1 transporter) interactions	Enzalutamide and M2 are inhibitors of P-gp at lower concentrations (IC ₅₀ : 0.775 µg/mL and 0.491 µg/mL, respectively), and inducers at higher concentrations (4.64 µg/mL and 4.50 µg/mL, respectively). Enzalutamide and M2 are not substrates of P-gp. M1 is not an inhibitor, inducer, nor substrate of P-gp. Enzalutamide has the potential to affect exposures to drugs that are substrates for the efflux transporter P-gp.
Breast Cancer Resistant Protein (BCRP) interactions	Enzalutamide, M1 and M2 are inhibitors of BCRP. Enzalutamide has the potential to affect exposures to drugs that are substrates of BCRP.
Organic anion transporters	M1 is a substrate of human organic anion transporters 3 (hOAT3) but not a substrate of hOAT1. Organic anion transporters 3 (OAT3) inhibitors have the potential to affect the exposure of M1.

- a. 12 human recombinant CYP isoforms: CYP1A1, CYP1A2, CYP2A6, CYP2B6, CYP2C8, CYP2C9, CYP2C18, CYP2C19, CYP2D6, CYP2E1, CYP3A4 and CYP3A5.
AUC, area under the curve; CYP, cytochrome P450; IC₅₀, concentration required for 50% inhibition; mRNA, messenger ribonucleic acid; P-gp, permeability-glycoprotein; µg/mL, micrograms per milliliter; µM, micromolar; cm/s, centimeters per second.

Human Pharmacology – *In Vivo*

See **DRUG INTERACTIONS** and **ACTION AND CLINICAL PHARMACOLOGY** sections.

The results of studies evaluating the Effect of Intrinsic/Extrinsic Factors on the PK of enzalutamide are shown in Figure 11.

Figure 11: Effect of Intrinsic/Extrinsic Factors on the PK of Enzalutamide

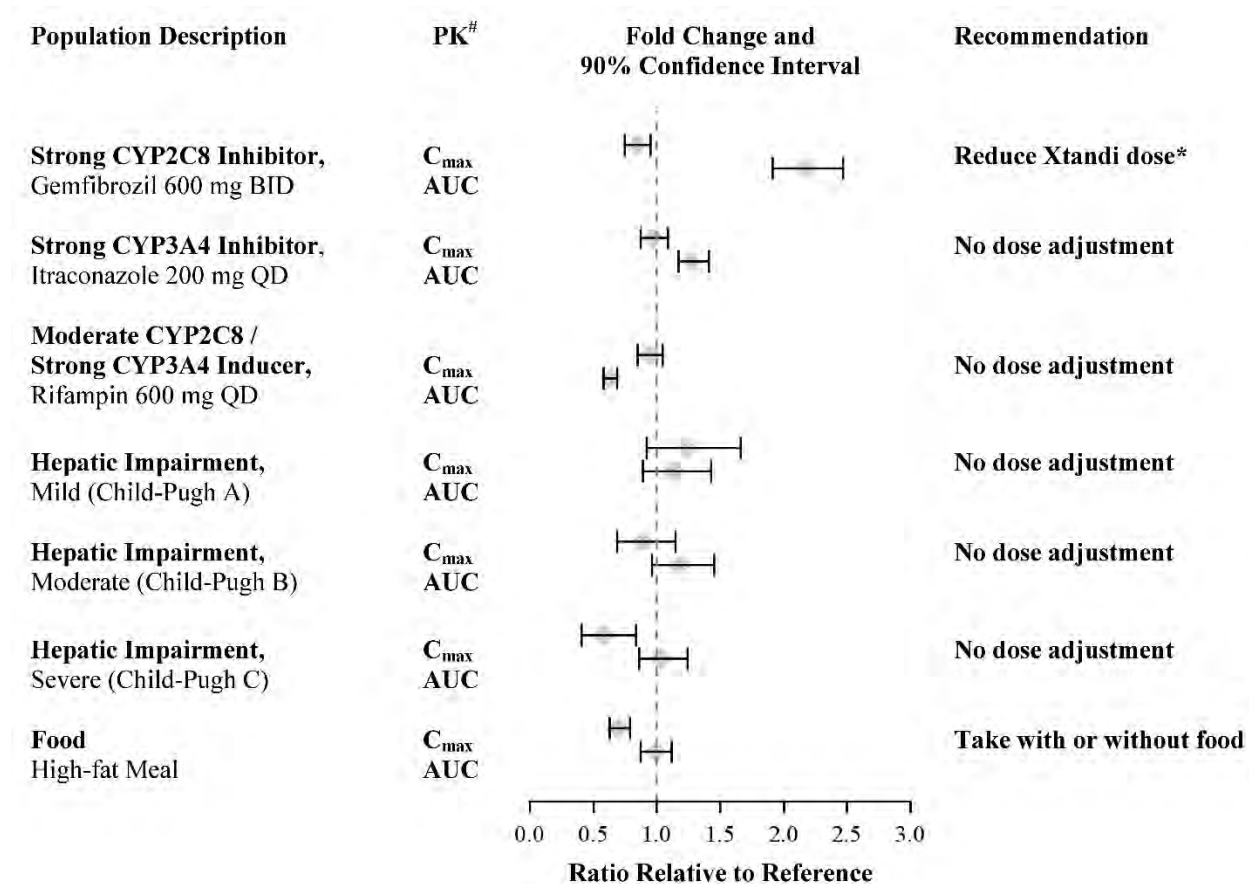

[#] PK parameters (C_{max} and AUC_{0-inf}) are for enzalutamide plus M2, except in the food-effect trial, where they are for enzalutamide alone.

* See Dosage and Administration.

See **Drug-Drug Interactions**.

In patients, the inter-subject variability, expressed as CV%, on the enzalutamide PK parameters AUC_τ, C_{min}, and C_{max} ranged from 23.0% to 29.3%. The inter-subject variability of the M2 PK parameters AUC_τ, C_{min} and C_{max} ranged from 29.7% to 30.9%. In a dose-escalation study, intra-subject variability on the enzalutamide PK parameter C_{min} ranged between 3% and 59% after once daily administration.

TOXICOLOGY

Safety pharmacology

In safety pharmacology studies, enzalutamide and its active metabolite M2, caused a concentration-dependent inhibition of hERG potassium currents in HEK293 cells with IC₅₀ values of 15.7 µM (7.3 µg/mL) and 18.6 µM (8.4 µg/mL), respectively. No treatment-related electrocardiographic effects were detected when enzalutamide was administered at single oral doses of 5, 15, or 30 mg/kg in a Latin square crossover conscious dog telemetry study (N = 4), but maximal plasma concentrations in the dogs were less than the human C_{max} at the therapeutic dose.

Repeated dose studies in mice

In mice dosed with 30 and 60 mg/kg/day enzalutamide for 4 weeks, changes related to the pharmacological activity included decreased weights of the epididymis, seminal vesicles and prostate. Decreased cytoplasmic vacuoles in the zona fasciculata were observed in all enzalutamide-dosed groups. Increased liver weight was observed in both sexes at 30 and 60 mg/kg/day and histopathology revealed hypertrophy of centrilobular hepatocytes. Thickening of mucosa in the forestomach was found in both sexes at 60 mg/kg/day, while ulcer and focal hyperplasia in the mucosa in the forestomach occurred only in the 60 mg/kg/day females. Two male animals dosed with 60 mg/kg/day died. All treatment-related changes observed at the end of the administration period were essentially reversible after a 4-week withdrawal of the test article. The doses used in mice (10, 30 and 60 mg/kg) resulted in systemic exposures (combined sex AUC) of 0.4, 1.0 and 1.4 times, respectively, the AUC in patients.

Repeated dose studies in rats

Morphological and/or histopathological changes were observed in the reproductive and hormone-sensitive organs of rats in all enzalutamide-dose groups in the 26-week repeated dose study. These changes included atrophy of the prostate and seminal vesicles, enlarged pituitary glands in females marked by hyperplasia on pars distalis, mammary gland atrophy in males and mammary gland hyperplasia in females. Effects on the pituitary and mammary glands persisted beyond the eight-week recovery period. Systemic exposure (combined sex AUC) at the doses used (10, 30 and 100 mg/kg/day) were 0.7, 1.4 and 1.8 times, respectively, the AUC in patients.

Repeated dose studies in dogs

In the 39-week study in dogs, atrophy of the prostate, epididymides and seminiferous tubules and hypertrophy and/or hyperplasia of the Leydig cells in the testes were observed in all enzalutamide-dose groups. In one male animal in the 45 mg/kg/day group, convulsions were observed before dosing on Day 13. Dosing in this animal was re-initiated on Day 17 and no recurrence of convulsions was observed in this animal or in any of the other animals up to the end of the study period. All changes to the reproductive organs were either partially or fully reversed after a thirteen-week recovery period. Systemic exposure (combined sex AUC) at the doses used (5, 15 and 45 mg/kg/day) were 0.4, 0.8 and 1.1 times, respectively, the AUC in patients.

Reproductive Toxicology

In a developmental toxicity study in mice, enzalutamide (10 and 30 mg/kg/day) caused embryo-fetal lethality (increased post-implantation loss and decreased number of live fetuses). Also at 10 and 30 mg/kg/day, there was a higher incidence of fetuses with external abnormalities (shortened anogenital distance). At 30 mg/kg/day, cleft palate and absent palatine bone were increased. The doses (1, 10, and 30 mg/kg/day) tested in mice resulted in systemic exposures (AUC) approximately 0.04, 0.4 and 1.1 times, respectively, the AUC in patients.

In the developmental toxicity study in rabbits, there were no treatment-related effects in any dam up to 10 mg/kg/day, although a preliminary study showed maternal and fetal toxicity at a dose of 30 mg/kg. No treatment-related effects were noted on the viability, growth, external, visceral, or skeletal morphology or the degree of ossification of embryos/fetuses up to 10 mg/kg/day. The No Observed Adverse Effect Level was considered to be 10 mg/kg/day for maternal general toxicity, maternal reproductive function and embryo-fetal development. At the tested doses (0.3, 3 and 10 mg/kg/day), the systemic exposures (AUC) were approximately 0.016, 0.1 and 0.36 times, respectively, the AUC in patients.

Overall, enzalutamide induced embryo-fetal deaths and/or external and skeletal abnormalities in mice and rabbits. These findings are consistent with the pharmacological activity of enzalutamide. For this reason, Xtandi is contraindicated in pregnancy.

Carcinogenesis and Genotoxicity

Enzalutamide was devoid of genotoxic potential in the standard panel of genotoxicity tests, including an *in vitro* bacterial reverse mutation (Ames) assay, *in vitro* mouse lymphoma thymidine kinase (Tk) gene mutation assay and in the *in vivo* mouse micronucleus assay. Metabolites M1 and M2 were not mutagenic in the bacterial Ames assay. M1 but not M2 showed mutagenic and clastogenic potential in the *in vitro* mouse lymphoma thymidine kinase assay at concentrations that also caused extensive cell death (≥ 50 $\mu\text{g/mL}$).

In a 6-month study in transgenic rasH2 mice, enzalutamide did not show carcinogenic potential (absence of neoplastic findings) at doses up to 20 mg/kg per day ($\text{AUC}_{24\text{h}} \sim 317$ $\mu\text{g}\cdot\text{h/mL}$), which resulted in plasma exposure levels similar to the clinical exposure ($\text{AUC}_{24\text{h}} 322$ $\mu\text{g}\cdot\text{h/mL}$) in metastatic CRPC patients receiving 160 mg daily.

Daily dosing of rats for two years with enzalutamide at 10–100 mg/kg/day produced an increased incidence of several, mostly benign, tumor types. The most prominent of these were benign Leydig cell tumours and urothelium papilloma and carcinoma of the urinary bladder in male rats. Benign Leydig cell tumours are expected based on the pharmacological properties of this antiandrogen drug and not considered relevant to humans. The observed urothelium papilloma and carcinoma of the urinary bladder may be due to continuous irritation caused by urinary bladder crystals/calculi which is more pronounced in rats because of anatomical differences and positioning of the rat urinary bladder (horizontal in rat versus upright in human). However, no obvious mechanistic rationale to explain specifically this malignancy can be established, and taking into account that exposure levels, based on AUC, achieved in the study, for enzalutamide plus its metabolites, were less than or similar to those in prostate cancer patients at the

recommended dose of 160 mg/day, urinary bladder carcinogenicity potential of enzalutamide in humans cannot be excluded. Other tumours include fibroadenoma of mammary glands and benign thymoma of thymus in males, benign granulosa cell tumours of ovaries in females and adenoma of pituitary pars distalis in both sexes. The exposure levels achieved in this study in male rats at week 26 at 100 mg/kg/day for enzalutamide plus its active metabolite M1 and M2 (AUC₂₄: enzalutamide ~457 µg•h/mL, M1 ~321 µg•h/mL, M2 ~35 µg•h/mL), were less than or similar to those in prostate cancer patients at the recommended dose (160 mg/day) of enzalutamide (AUC₂₄: enzalutamide ~322 µg•h/mL, M1 ~193 µg•h/mL, M2 ~278 µg•h/mL).

REFERENCES

1. Beer T.M., Armstrong A.J., Rathkopf D.E., *et al* Enzalutamide in Metastatic Prostate Cancer before Chemotherapy. *N Engl J Med* Jun 01, 2014: 1-10.
2. Chen Y., Clegg N.J., Scher H.I. Anti-androgens and androgen-depleting therapies in prostate cancer: new agents for an established target. *Lancet Oncol* 2009; 10:981-991.
3. Scher H.I., Beer T.M., Higano C.S *et al*. Antitumour activity of enzalutamide in castration-resistant prostate cancer: a phase 1–2 study. *Lancet* 2010; 375:1437-46.
4. Scher HI, Fizazi K, Saad F, *et al*. Increased survival with enzalutamide in Prostate Cancer after chemotherapy. *N Engl J Med* Aug 15, 2012: 1-11.
5. Tran C, Ouk S, Clegg NJ *et al*. Development of a second-generation antiandrogen for treatment of advanced prostate cancer. *Science* 2009; 324(5928):787-790.

PART III: CONSUMER INFORMATION

Pr**Xtandi**[®]
(enzalutamide capsules)

This leaflet is part III of a three-part "Product Monograph" published when Xtandi[®] was approved for sale in Canada and is designed specifically for Consumers. This leaflet is a summary and will not tell you everything about Xtandi. Contact your doctor or pharmacist if you have any questions about the drug.

ABOUT THIS MEDICATION**What the medication is used for:**

Xtandi is used to treat prostate cancer that has spread to other parts of the body in men who:

- are receiving but no longer responding to the medicine or surgery to lower testosterone. They may have also received a cancer treatment with a drug called docetaxel.
- still respond to a medicine or surgery that lowers testosterone.

Xtandi is used to treat men with prostate cancer that has not spread to other parts of the body but no longer responds to medicine or surgery that lowers testosterone. Xtandi has not been studied in patients with low risk of the cancer spreading to other parts of the body. Talk to your healthcare professional if you have questions about this.

What it does:

Xtandi blocks the activity of hormones called androgens (like testosterone), which can slow the growth of prostate cancer.

When it should not be used:

- If you are allergic to enzalutamide or to any of the ingredients in the medicine
- If you are or may become pregnant.
- If you are breast-feeding.

What the medicinal ingredient is:

enzalutamide

What the nonmedicinal ingredients are:

caprylocaproyl macrogolglycerides, butylhydroxyanisole (E320), butylhydroxytoluene (E321)

Capsule Shell: gelatin, sorbitol sorbitan solution, glycerol, titanium dioxide (E171), purified water

Printing ink: ethanol, ethyl acetate, propylene glycol, iron oxide black (E172), polyvinyl acetate phthalate, purified water, isopropyl alcohol, macrogol 400, ammonia solution concentrated

What dosage forms it comes in:

Xtandi is available as a 40 mg white to off-white, oblong, liquid-filled, soft capsule. The letters "ENZ" are printed in black on each capsule.

WARNINGS AND PRECAUTIONS**Serious Warnings and Precautions**

Xtandi should only be prescribed by a doctor experienced with the treatment of prostate cancer.

Clinically significant adverse events:

- Seizures
- Posterior Reversible Encephalopathy Syndrome

Be careful if you are engaging in activities that require mental concentration or where sudden loss of consciousness could cause serious harm to others (e.g. driving or operating tools or machines).

BEFORE you use Xtandi, talk to your doctor or pharmacist:

- If you have history of seizures or are at a high risk of seizures (see below paragraph on situations in which you may have a higher risk of seizures).
- If you have problems with your liver or kidneys.
- If you have any heart disorder, including an irregular heartbeat, an abnormal electrical signal called "prolongation of the QT interval" or a known history of QT interval prolongation.
- If you have high blood pressure. Xtandi can increase your blood pressure. Your doctor will measure your blood pressure before starting treatment with Xtandi and periodically during treatment.
- If you have a history of fainting spells.
- If you have a risk for falls or broken bones.
- If you have electrolyte disturbances (e.g. low blood potassium or magnesium levels) or conditions that could lead to electrolyte disturbances (e.g. vomiting, diarrhea, dehydration, eating disorder).
- If you have fructose intolerance, which is a rare hereditary problem. This is because Xtandi contains sorbitol.
- About all medicines (including natural health products) you have recently taken or are currently taking.

You should not start or stop Xtandi before you talk to your healthcare provider that prescribed you Xtandi.

Men who are sexually active with a pregnant woman must use a condom during and for three months after stopping treatment with Xtandi. If their sexual partner could become pregnant, a condom and another form of birth control must be used during and for three months after treatment.

Xtandi should not be given to patients less than 18 years of age.

Seizures

About 4 in every 1,000 people taking Xtandi are at risk of having a seizure.

Tell your doctor, pharmacist or nurse if you are taking any of the following medicines. When taken at the same time as Xtandi, these medicines may increase the risk of a seizure:

- Certain medicines used to treat asthma and other respiratory diseases (e.g. aminophylline, theophylline)
- Medicines used to treat certain psychiatric disorders such as depression and schizophrenia (e.g. clozapine, olanzapine, risperidone, ziprasidone, bupropion, lithium, chlorpromazine, mesoridazine, thioridazine, amitriptyline, desipramine, doxepin, imipramine, maprotiline, mirtazapine, venlafaxine)
- Certain medicines for the treatment of pain (e.g. meperidine)

Some situations in which you may have a higher risk of seizures include:

- If you had earlier episodes of seizures
- If you drink very large amounts of alcohol either regularly or from time to time
- If you have had a serious head injury or a history of head trauma
- If you have had certain kinds of stroke
- If you have had a brain tumour or metastases of cancer in the brain
- If you are taking a medicine that can cause seizures or that can increase the susceptibility for having seizures

If you have a seizure during treatment: Stop taking Xtandi and see your doctor, pharmacist or nurse as soon as possible.

Posterior Reversible Encephalopathy Syndrome (PRES)

Reversible swelling in the rear part of the brain that can be associated with high blood pressure and can lead to headache, loss of speech or vision, confusion and/or seizure. Contact your doctor right away if you experience any of these symptoms.

INTERACTIONS WITH THIS MEDICATION

Certain medicines may interact with Xtandi. These include drugs used to:

- Treat bacterial infections (e.g. clarithromycin, doxycycline)
- Treat certain psychiatric disorders such as severe anxiety or schizophrenia (e.g. diazepam, haloperidol, midazolam)
- Treat gout (colchicine)
- Lower cholesterol (e.g. atorvastatin, simvastatin)
- Treat heart conditions and lower blood pressure (e.g. bisoprolol, digoxin, diltiazem, felodipine, nifedipine, propranolol, verapamil)
- Treat serious disease related to inflammation (e.g. dexamethasone, prednisone)
- Prevent the rejection of organ transplants (e.g. cyclosporine, tacrolimus)
- Treat HIV infection (e.g. indinavir, ritonavir)

- Treat epilepsy (e.g. carbamazepine, clonazepam, phenobarbital, phenytoin, primidone, valproic acid)
- Prevent blood clots (e.g. acenocoumarol, dabigatran etexilate, warfarin, clopidogrel)
- Treat cancer (e.g. cabazitaxel, irinotecan, sunitinib)
- Treat pain (e.g. fentanyl, tramadol)
- Treat thyroid conditions (e.g. levothyroxine)
- Treat stomach disorders (e.g. omeprazole)

Tell your doctor, pharmacist or nurse if you are taking any of the medicines listed above. You should check with your doctor, pharmacist, or nurse before taking any other medications with Xtandi. The dose of any other medicines that you are taking may need to be changed.

PROPER USE OF THIS MEDICATION

Usual dose:

The usual dose is 160 mg (4 capsules) taken once a day. The dose should be taken at the same time each day. Swallow the capsules whole with water. Do not chew, dissolve or open the capsules. You can take this medicine with or without food.

Overdose:

If you take more drug than prescribed, stop taking Xtandi and contact your doctor. You may be at increased risk for seizure.

In case of drug overdose, contact a health care practitioner, hospital emergency department or regional Poison Control Centre immediately, even if there are no symptoms.

Missed Dose:

- If you forget to take Xtandi at the usual time, take your usual dose as soon as you remember.
- If you forget to take Xtandi for the whole day, take your usual dose the following day.
- If you forget to take Xtandi for more than one day, talk to your doctor without delay.

Do not take a double dose to make up for the dose you forgot.

Xtandi should not be handled by persons other than the patient or their caregivers. Women who are or may become pregnant should not handle damaged or opened Xtandi capsules without protection (e.g. gloves). Xtandi might harm your unborn baby.

SIDE EFFECTS AND WHAT TO DO ABOUT THEM

As with all medicines, Xtandi can cause side effects, although not everybody gets them. The following side effects may happen while taking this medicine.

Very Common side effects (affects more than 1 in 10 people):

- Feeling tired (fatigue)

- Back pain
- Hot flush
- Constipation
- Joint Pain
- Decreased appetite
- Diarrhea
- High blood pressure
- Dizziness/vertigo
- Headache

Common side effects (affects less than 1 in 10 people):

- Feeling anxious
- Forgetfulness
- Having trouble remembering and solving problems
- Reduced concentration
- Weight loss
- Disturbance in attention
- Dry skin, itching
- Nose bleed
- Shingles
- Flu-like symptoms
- Drowsiness
- Uncontrollable urge to move a part of the body, usually the leg (restless leg syndrome)

Uncommon side effects (affects less than 1 in 100 people):

- Hallucinations
- Bleeding in digestive tract
- Low white blood cell count
- Bruising
- Breast swelling in males

Unknown frequency:

- Vomiting
- Nausea
- Rash

If you experience any symptoms of a possible heart rhythm disturbance, such as dizziness, palpitations, or fainting, you should seek immediate medical attention.

About 4 in every 1,000 people taking Xtandi are at risk of having a seizure. Seizures are more likely if you take more than the recommended dose of this medicine, if you take some other medicines, or if you are at higher than usual risk of seizures.

Xtandi can cause abnormal blood test results. Your doctor will decide when to perform blood tests and will interpret the results.

Tell your doctor or pharmacist if you have any side effects while taking Xtandi. This includes any side effects not listed above.

SERIOUS SIDE EFFECTS, HOW OFTEN THEY HAPPEN AND WHAT TO DO ABOUT THEM

Symptom / effect	Talk with your doctor or pharmacist		Stop taking drug and get immediate medical help
	Only if severe	In all cases	
Common (may affect 1.0% to 10% of people)			
Cardiac Problems (including heart attack, angina, coronary artery disease or heart failure): pressure or pain in your chest or arms that may spread to your neck jaw or back, shortness of breath, changes in heartrate, dizziness or lightheadedness, nausea		✓	✓
Falls		✓	
Bone Fractures (broken bones)		✓	
Uncommon (may affect 0.1% to 1% of people)			
Seizure: muscle twitching, changes in emotions, loss of consciousness with uncontrollable shaking		✓	✓
Sepsis and septic shock (Infection of the blood): fever or dizziness, chills, high or very low body temperature, little or no urine, low blood pressure, palpitations, rapid breathing, rapid heartbeat.			✓
Reported from post-marketing (unknown frequency)			
Posterior Reversible Encephalopathy Syndrome (PRES swelling in the rear part of the brain that can resolve): high blood pressure, headache, loss of speech or vision, confusion, seizure		✓	✓
Allergic reaction: rash, hives, swelling of the face, tongue, lip or throat, difficulty swallowing or breathing		✓	✓

This is not a complete list of side effects. For any unexpected effects while taking Xtandi, contact your doctor or pharmacist.

HOW TO STORE IT

Store between 15°C - 30°C. Keep out of the reach and sight of children.

REPORTING SUSPECTED SIDE EFFECTS

You can report any suspected adverse reactions associated with the use of health products to the Canada Vigilance Program by one of the following 3 ways:

- Report online at <https://www.canada.ca/en/health-canada/services/drugs-health-products/medeffect-canada.html>
- Call toll-free at 1-866-234-2345
- Complete a Canada Vigilance Reporting Form and:
 - Fax toll-free to 1-866-678-6789, or
 - Mail to: Canada Vigilance Program
Health Canada
Postal Locator 1908C
Ottawa, Ontario K1A 0K9

Postage-paid labels, Canada Vigilance Reporting Form and the adverse reaction reporting guidelines are available on the MedEffect™ Canada Web site at <https://www.canada.ca/en/health-canada/services/drugs-health-products/medeffect-canada.html>.

NOTE: Should you require information related to the management of side effects, contact your health professional. The Canada Vigilance Program does not provide medical advice.

<http://www.astellas.ca>

or by contacting the sponsor, Astellas Pharma Canada, Inc., at:
1-888-338-1824

Xtandi® is a registered trademark of Astellas Pharma Inc.

This leaflet was prepared by Astellas Pharma Canada, Inc.

Last revised: June 1, 2020

251041-XTA-CAN

MORE INFORMATION

This document plus the full product monograph, prepared for health professionals can be found at:

HIGHLIGHTS OF PRESCRIBING INFORMATION

These highlights do not include all the information needed to use XTANDI® safely and effectively. See full prescribing information for XTANDI.

XTANDI® (enzalutamide) capsules, for oral use

XTANDI® (enzalutamide) tablets, for oral use

Initial U.S. Approval: 2012

RECENT MAJOR CHANGES

Indications and Usage (1)	12/2019
Dosage and Administration – Dosing Information (2.1)	10/2020
Warnings and Precautions, Seizure (5.1)	12/2019
Warnings and Precautions, Hypersensitivity (5.3)	12/2019
Warnings and Precautions, Ischemic Heart Disease (5.4)	12/2019
Warnings and Precautions, Falls and Fractures (5.5)	12/2019

INDICATIONS AND USAGE

XTANDI is an androgen receptor inhibitor indicated for the treatment of patients with:

- castration-resistant prostate cancer. (1)
- metastatic castration-sensitive prostate cancer. (1)

DOSAGE AND ADMINISTRATION

XTANDI 160 mg (two 80 mg tablets or four 40 mg tablets or four 40 mg capsules) administered orally once daily. Swallow capsules or tablets whole. (2.1)

Patients receiving XTANDI should also receive a gonadotropin-releasing hormone (GnRH) analog concurrently or should have had bilateral orchiectomy. (2.3)

DOSAGE FORMS AND STRENGTHS

Capsule 40 mg (3)
Tablet: 40 mg, 80 mg (3)

CONTRAINDICATIONS

None. (4)

WARNINGS AND PRECAUTIONS

- Seizure occurred in 0.5% of patients receiving XTANDI. In patients with predisposing factors, seizures were reported in 2.2%

of patients. Permanently discontinue XTANDI in patients who develop a seizure during treatment. (5.1)

- Posterior reversible encephalopathy syndrome (PRES): Discontinue XTANDI. (5.2)
- Hypersensitivity: Discontinue XTANDI. (5.3)
- Ischemic Heart Disease: Optimize management of cardiovascular risk factors. Discontinue XTANDI for Grade 3-4 events. (5.4)
- Falls and Fractures occurred in 11% and 10% of patients receiving XTANDI, respectively. Evaluate patients for fracture and fall risk, and treat patients with bone-targeted agents according to established guidelines. (5.5)
- Embryo-Fetal Toxicity: XTANDI can cause fetal harm and loss of pregnancy. Advise males with female partners of reproductive potential to use effective contraception. (5.6, 8.1, 8.3)

ADVERSE REACTIONS

The most common adverse reactions (≥ 10%) that occurred more frequently (≥ 2% over placebo) in the XTANDI-treated patients are asthenia/fatigue, back pain, hot flush, constipation, arthralgia, decreased appetite, diarrhea, and hypertension. (6.1)

To report SUSPECTED ADVERSE REACTIONS, contact Astellas Pharma US, Inc. at 1-800-727-7003 or FDA at 1-800-FDA-1088 or www.fda.gov/medwatch.

DRUG INTERACTIONS

- Avoid strong CYP2C8 inhibitors, as they can increase the plasma exposure to XTANDI. If co-administration is necessary, reduce the dose of XTANDI. (2.2, 7.1)
- Avoid strong CYP3A4 inducers as they can decrease the plasma exposure to XTANDI. If co-administration is necessary, increase the dose of XTANDI. (2.2, 7.2)
- Avoid CYP3A4, CYP2C9 and CYP2C19 substrates with a narrow therapeutic index, as XTANDI may decrease the plasma exposures of these drugs. If XTANDI is co-administered with warfarin (CYP2C9 substrate), conduct additional INR monitoring. (7.3)

See 17 for PATIENT COUNSELING INFORMATION and FDA-approved patient labeling

Revised: 10/2020

FULL PRESCRIBING INFORMATION: CONTENTS*

1 INDICATIONS AND USAGE

2 DOSAGE AND ADMINISTRATION

- Dosing Information
- Dose Modifications
- Important Administration Instructions

3 DOSAGE FORMS AND STRENGTHS

4 CONTRAINDICATIONS

5 WARNINGS AND PRECAUTIONS

- Seizure
- Posterior Reversible Encephalopathy Syndrome (PRES)
- Hypersensitivity
- Ischemic Heart Disease
- Falls and Fractures
- Embryo-Fetal Toxicity

6 ADVERSE REACTIONS

- Clinical Trial Experience
- Post-Marketing Experience

7 DRUG INTERACTIONS

- Drugs that Inhibit CYP2C8
- Drugs that Induce CYP3A4
- Effect of XTANDI on Drug Metabolizing Enzymes

8 USE IN SPECIFIC POPULATIONS

- Pregnancy
- Lactation
- Females and Males of Reproductive Potential
- Pediatric Use
- Geriatric Use
- Patients with Renal Impairment
- Patients with Hepatic Impairment

10 OVERDOSAGE

11 DESCRIPTION

12 CLINICAL PHARMACOLOGY

- Mechanism of Action
- Pharmacodynamics
- Pharmacokinetics

13 NONCLINICAL TOXICOLOGY

- Carcinogenesis, Mutagenesis, Impairment of Fertility

14 CLINICAL STUDIES

16 HOW SUPPLIED/STORAGE AND HANDLING

17 PATIENT COUNSELING INFORMATION

*Sections or subsections omitted from the full prescribing information are not listed.

FULL PRESCRIBING INFORMATION

1 INDICATIONS AND USAGE

XTANDI® is indicated for the treatment of patients with:

- castration-resistant prostate cancer (CRPC)
- metastatic castration-sensitive prostate cancer (mCSPC)

2 DOSAGE AND ADMINISTRATION

2.1 Dosing Information

The recommended dose of XTANDI is 160 mg (two 80 mg tablets or four 40 mg tablets or four 40 mg capsules) administered orally once daily. XTANDI can be taken with or without food [see [Clinical Pharmacology \(12.3\)](#)]. Swallow capsules or tablets whole. Do not chew, dissolve, or open the capsules. Do not cut, crush, or chew the tablets [see [How Supplied/Storage and Handling \(16\)](#)].

2.2 Dose Modifications

If a patient experiences a \geq Grade 3 toxicity or an intolerable side effect, withhold dosing for one week or until symptoms improve to \leq Grade 2, then resume at the same or a reduced dose (120 mg or 80 mg), if warranted [see [Warnings and Precautions \(5.1\), \(5.2\)](#)].

Concomitant Strong CYP2C8 Inhibitors

The concomitant use of strong CYP2C8 inhibitors should be avoided if possible. If patients must be co-administered a strong CYP2C8 inhibitor, reduce the XTANDI dose to 80 mg once daily. If co-administration of the strong inhibitor is discontinued, the XTANDI dose should be returned to the dose used prior to initiation of the strong CYP2C8 inhibitor [see [Drug Interactions \(7.1\)](#) and [Clinical Pharmacology \(12.3\)](#)].

Concomitant Strong CYP3A4 Inducers

The concomitant use of strong CYP3A4 inducers should be avoided if possible. If patients must be co-administered a strong CYP3A4 inducer, increase the XTANDI dose from 160 mg to 240 mg once daily. If co-administration of the strong CYP3A4 inducer is discontinued, the XTANDI dose should be returned to the dose used prior to initiation of the strong CYP3A4 inducer [see [Drug Interactions \(7.2\)](#) and [Clinical Pharmacology \(12.3\)](#)].

2.3 Important Administration Instructions

Patients receiving XTANDI should also receive a gonadotropin-releasing hormone (GnRH) analog concurrently or should have had bilateral orchiectomy.

3 DOSAGE FORMS AND STRENGTHS

XTANDI 40 mg capsules are white to off-white oblong soft gelatin capsules imprinted in black ink with ENZ.

XTANDI 40 mg tablets are yellow, round, film-coated and debossed with E 40.

XTANDI 80 mg tablets are yellow, oval, film-coated and debossed with E 80.

4 CONTRAINDICATIONS

None.

5 WARNINGS AND PRECAUTIONS

5.1 Seizure

Seizure occurred in 0.5% of patients receiving XTANDI in seven randomized clinical trials. In these trials, patients with predisposing factors for seizure were generally excluded. Seizure occurred from 13 to 1776 days after initiation of XTANDI. Patients experiencing seizure were permanently discontinued from therapy, and all seizure events resolved.

In a single-arm trial designed to assess the risk of seizure in patients with pre-disposing factors for seizure, 8 of 366 (2.2%) XTANDI-treated patients experienced a seizure. Three of the 8 patients experienced a second seizure during continued treatment with XTANDI after their first seizure resolved. It is unknown whether anti-epileptic medications will prevent seizures with XTANDI. Patients in the study had one or more of the following pre-disposing factors: the use of medications that may lower the seizure threshold (~ 54%), history of traumatic brain or head injury (~ 28%), history of cerebrovascular accident or transient ischemic attack (~ 24%), and Alzheimer's disease, meningioma, or leptomeningeal disease from prostate cancer, unexplained loss of consciousness within the last 12 months, past history of seizure, presence of a space occupying lesion of the brain, history of arteriovenous malformation, or history of brain infection (all < 5%). Approximately 17% of patients had more than one risk factor.

Advise patients of the risk of developing a seizure while receiving XTANDI and of engaging in any activity where sudden loss of consciousness could cause serious harm to themselves or others.

Permanently discontinue XTANDI in patients who develop a seizure during treatment.

5.2 Posterior Reversible Encephalopathy Syndrome (PRES)

There have been reports of posterior reversible encephalopathy syndrome (PRES) in patients receiving XTANDI [*see [Adverse Reactions \(6.2\)](#)*]. PRES is a neurological disorder which can present with rapidly evolving symptoms including seizure, headache, lethargy, confusion, blindness, and other visual and neurological disturbances, with or without associated hypertension. A diagnosis of PRES requires confirmation by brain imaging, preferably magnetic resonance imaging (MRI). Discontinue XTANDI in patients who develop PRES.

5.3 Hypersensitivity

Hypersensitivity reactions, including edema of the face (0.5%), tongue (0.1%), or lip (0.1%) have been observed with enzalutamide in seven randomized clinical trials. Pharyngeal edema has been reported in post-marketing cases. Advise patients who experience any symptoms of hypersensitivity to temporarily discontinue XTANDI and promptly seek medical care. Permanently discontinue XTANDI for serious hypersensitivity reactions.

5.4 Ischemic Heart Disease

In the combined data of four randomized, placebo-controlled clinical studies, ischemic heart disease occurred more commonly in patients on the XTANDI arm compared to patients on the placebo arm (2.9% vs 1.3%). Grade 3-4 ischemic events occurred in 1.4% of patients on the XTANDI arm compared to 0.7% on the placebo arm. Ischemic events led to death in 0.4% of patients on the XTANDI arm compared to 0.1% on the placebo arm.

Monitor for signs and symptoms of ischemic heart disease. Optimize management of cardiovascular risk factors, such as hypertension, diabetes, or dyslipidemia. Discontinue XTANDI for Grade 3-4 ischemic heart disease.

5.5 Falls and Fractures

Falls and fractures occurred in patients receiving XTANDI. Evaluate patients for fracture and fall risk. Monitor and manage patients at risk for fractures according to established treatment guidelines and consider use of bone-targeted agents.

In the combined data of four randomized, placebo-controlled clinical studies, falls occurred in 11% of patients treated with XTANDI compared to 4% of patients treated with placebo. Falls were not associated with loss of consciousness or seizure. Fractures occurred in 10% of patients treated with XTANDI and in 4% of patients treated with placebo. Grade 3-4 fractures occurred in 3% of patients treated with XTANDI and in 2% of patients treated with placebo. The median time to onset of fracture was 336 days (range: 2 to 1914 days) for patients treated with XTANDI. Routine bone density assessment and treatment of osteoporosis with bone-targeted agents were not performed in the studies.

5.6 Embryo-Fetal Toxicity

The safety and efficacy of XTANDI have not been established in females. Based on animal reproductive studies and mechanism of action, XTANDI can cause fetal harm and loss of pregnancy when administered to a pregnant female. Advise males with female partners of reproductive potential to use effective contraception during treatment with XTANDI and for 3 months after the last dose of XTANDI [see [Use in Specific Populations \(8.1, 8.3\)](#)].

6 ADVERSE REACTIONS

The following is discussed in more detail in other sections of the labeling:

- Seizure [see [Warnings and Precautions \(5.1\)](#)]
- Posterior Reversible Encephalopathy Syndrome (PRES) [see [Warnings and Precautions \(5.2\)](#)]
- Hypersensitivity [see [Warnings and Precautions \(5.3\)](#)]
- Ischemic Heart Disease [see [Warnings and Precautions \(5.4\)](#)]
- Falls and Fractures [see [Warnings and Precautions \(5.5\)](#)]

6.1 Clinical Trial Experience

Because clinical trials are conducted under widely varying conditions, adverse reaction rates observed in the clinical trials of a drug cannot be directly compared to rates in the clinical trials of another drug and may not reflect the rates observed in practice.

The data in WARNINGS and PRECAUTIONS reflect seven randomized, controlled trials [AFFIRM, PREVAIL, TERRAIN, PROSPER, ARCHES, Asian PREVAIL (NCT02294461), and STRIVE (NCT01664923)] that were pooled to conduct safety analyses in patients with CRPC (N=3509) or mCSPC (N= 572) treated with XTANDI. Patients received XTANDI 160 mg (N= 4081) or placebo orally once daily (N= 2472) or bicalutamide 50 mg orally once daily (N= 387). All patients continued androgen deprivation therapy (ADT). In these seven trials, the median duration of treatment was 13.8 months (range: <0.1 to 87.6) in the XTANDI group.

In four placebo-controlled trials (AFFIRM, PROSPER, PREVAIL, and ARCHES), the median duration of treatment was 14.3 months (range: <0.1 to 87.6) in the XTANDI group [see [Clinical Studies \(14\)](#)]. In these four trials, the most common adverse reactions ($\geq 10\%$) that occurred more frequently ($\geq 2\%$ over placebo) in the XTANDI-treated patients were asthenia/fatigue, back pain, hot flush, constipation, arthralgia, decreased appetite, diarrhea, and hypertension.

AFFIRM (NCT00974311): XTANDI versus Placebo in Metastatic CRPC Following Chemotherapy

AFFIRM enrolled 1199 patients with metastatic CRPC who had previously received docetaxel. The median duration of treatment was 8.3 months with XTANDI and 3.0 months with placebo. During the trial, 48% of patients on the XTANDI arm and 46% of patients on the placebo arm received glucocorticoids.

Grade 3 and higher adverse reactions were reported among 47% of XTANDI-treated patients. Discontinuations due to adverse events were reported for 16% of XTANDI-treated patients. The most common adverse reaction leading to treatment discontinuation was seizure, which occurred in 0.9% of the XTANDI-treated patients compared to none (0%) of the placebo-treated patients. [Table 1](#) shows adverse reactions reported in AFFIRM that occurred at a $\geq 2\%$ higher frequency in the XTANDI arm compared to the placebo arm.

Table 1. Adverse Reactions in AFFIRM

	XTANDI (N = 800)		Placebo (N = 399)	
	Grade 1-4' (%)	Grade 3-4 (%)	Grade 1-4 (%)	Grade 3-4 (%)
General Disorders				
Asthenic Conditions ²	51	9.0	44	9.3
Peripheral Edema	15	1.0	13	0.8
Musculoskeletal and Connective Tissue Disorders				
Back Pain	26	5.3	24	4.0
Arthralgia	21	2.5	17	1.8
Musculoskeletal Pain	15	1.3	12	0.3
Muscular Weakness	9.8	1.5	6.8	1.8
Musculoskeletal Stiffness	2.6	0.3	0.3	0.0
Gastrointestinal Disorders				
Diarrhea	22	1.1	18	0.3
Vascular Disorders				
Hot Flush	20	0.0	10	0.0
Hypertension	6.4	2.1	2.8	1.3
Nervous System Disorders				
Headache	12	0.9	5.5	0.0
Dizziness ³	9.5	0.5	7.5	0.5
Spinal Cord Compression and Cauda Equina Syndrome	7.4	6.6	4.5	3.8
Paresthesia	6.6	0.0	4.5	0.0
Mental Impairment Disorders ⁴	4.3	0.3	1.8	0.0
Hypoesthesia	4.0	0.3	1.8	0.0
Infections and Infestations				
Upper Respiratory Tract Infection ⁵	11	0.0	6.5	0.3
Lower Respiratory Tract And Lung Infection ⁶	8.5	2.4	4.8	1.3
Psychiatric Disorders				
Insomnia	8.8	0.0	6.0	0.5
Anxiety	6.5	0.3	4.0	0.0
Renal and Urinary Disorders				
Hematuria	6.9	1.8	4.5	1.0
Pollakiuria	4.8	0.0	2.5	0.0
Injury, Poisoning and Procedural Complications				
Fall	4.6	0.3	1.3	0.0
Non-pathologic Fractures	4.0	1.4	0.8	0.3
Skin and Subcutaneous Tissue Disorders				
Pruritus	3.8	0.0	1.3	0.0
Dry Skin	3.5	0.0	1.3	0.0
Respiratory Disorders				
Epistaxis	3.3	0.1	1.3	0.3

1. CTCAE v4

2. Includes asthenia and fatigue.

3. Includes dizziness and vertigo.

4. Includes amnesia, memory impairment, cognitive disorder, and disturbance in attention.

5. Includes nasopharyngitis, upper respiratory tract infection, sinusitis, rhinitis, pharyngitis, and laryngitis.

6. Includes pneumonia, lower respiratory tract infection, bronchitis, and lung infection.

PREVAIL (NCT01212991): XTANDI versus Placebo in Chemotherapy-naïve Metastatic CRPC

PREVAIL enrolled 1717 patients with metastatic CRPC who had not received prior cytotoxic chemotherapy, of whom 1715 received at least one dose of study drug. The median duration of treatment was 17.5 months with XTANDI and 4.6 months with placebo. Grade 3-4 adverse reactions were reported in 44% of XTANDI-treated patients and 37% of placebo-treated patients. Discontinuations due to adverse events were reported for 6% of XTANDI-treated patients. The most common adverse reaction leading to treatment discontinuation was fatigue/asthenia, which occurred in 1% of patients on each treatment arm. [Table 2](#) includes adverse reactions reported in PREVAIL that occurred at a $\geq 2\%$ higher frequency in the XTANDI arm compared to the placebo arm.

Table 2. Adverse Reactions in PREVAIL

	XTANDI (N = 871)		Placebo (N = 844)	
	Grade 1-4 ¹ (%)	Grade 3-4 (%)	Grade 1-4 (%)	Grade 3-4 (%)
General Disorders				
Asthenic Conditions ²	47	3.4	33	2.8
Peripheral Edema	12	0.2	8.2	0.4
Musculoskeletal and Connective Tissue Disorders				
Back Pain	29	2.5	22	3.0
Arthralgia	21	1.6	16	1.1
Gastrointestinal Disorders				
Constipation	23	0.7	17	0.4
Diarrhea	17	0.3	14	0.4
Vascular Disorders				
Hot Flush	18	0.1	7.8	0.0
Hypertension	14	7.2	4.1	2.3
Nervous System Disorders				
Dizziness ³	11	0.3	7.1	0.0
Headache	11	0.2	7.0	0.4
Dysgeusia	7.6	0.1	3.7	0.0
Mental Impairment Disorders ⁴	5.7	0.0	1.3	0.1
Restless Legs Syndrome	2.1	0.1	0.4	0.0
Respiratory Disorders				
Dyspnea ⁵	11	0.6	8.5	0.6
Infections and Infestations				
Upper Respiratory Tract Infection ⁶	16	0.0	11	0.0
Lower Respiratory Tract And Lung Infection ⁷	7.9	1.5	4.7	1.1
Psychiatric Disorders				
Insomnia	8.2	0.1	5.7	0.0
Renal and Urinary Disorders				
Hematuria	8.8	1.3	5.8	1.3
Injury, Poisoning and Procedural Complications				
Fall	13	1.6	5.3	0.7
Non-Pathological Fracture	8.8	2.1	3.0	1.1
Metabolism and Nutrition Disorders				
Decreased Appetite	19	0.3	16	0.7
Investigations				
Weight Decreased	12	0.8	8.5	0.2
Reproductive System and Breast Disorders				
Gynecomastia	3.4	0.0	1.4	0.0

1. CTCAE v4

2. Includes asthenia and fatigue.
3. Includes dizziness and vertigo.
4. Includes amnesia, memory impairment, cognitive disorder, and disturbance in attention.
5. Includes dyspnea, exertional dyspnea, and dyspnea at rest.
6. Includes nasopharyngitis, upper respiratory tract infection, sinusitis, rhinitis, pharyngitis, and laryngitis.
7. Includes pneumonia, lower respiratory tract infection, bronchitis, and lung infection.

TERRAIN (NCT01288911): XTANDI versus Bicalutamide in Chemotherapy-naïve Metastatic CRPC

TERRAIN enrolled 375 patients with metastatic CRPC who had not received prior cytotoxic chemotherapy, of whom 372 received at least one dose of study drug. The median duration of treatment was 11.6 months with XTANDI and 5.8 months with bicalutamide. Discontinuations with an adverse event as the primary reason were reported for 7.6% of XTANDI-treated patients and 6.3% of bicalutamide-treated patients. The most common adverse reactions leading to treatment discontinuation were back pain and pathological fracture, which occurred in 3.8% of XTANDI-treated patients for each event and in 2.1% and 1.6% of bicalutamide-treated patients, respectively. [Table 3](#) shows overall and common adverse reactions ($\geq 10\%$) in XTANDI-treated patients.

Table 3. Adverse Reactions in TERRAIN

	XTANDI (N = 183)		Bicalutamide (N = 189)	
	Grade 1-4 ¹ (%)	Grade 3-4 (%)	Grade 1-4 (%)	Grade 3-4 (%)
Overall	94	39	94	38
General Disorders				
Asthenic Conditions ²	32	1.6	23	1.1
Musculoskeletal and Connective Tissue Disorders				
Back Pain	19	2.7	18	1.6
Musculoskeletal Pain ³	16	1.1	14	0.5
Vascular Disorders				
Hot Flush	15	0	11	0
Hypertension	14	7.1	7.4	4.2
Gastrointestinal Disorders				
Nausea	14	0	18	0
Constipation	13	1.1	13	0.5
Diarrhea	12	0	9.0	1.1
Infections and Infestations				
Upper Respiratory Tract Infection ⁴	12	0	6.3	0.5
Investigational				
Weight Loss	11	0.5	7.9	0.5

1. CTCAE v 4
2. Including asthenia and fatigue.
3. Including musculoskeletal pain and pain in extremity.
4. Including nasopharyngitis, upper respiratory tract infection, sinusitis, rhinitis, pharyngitis, and laryngitis.

PROSPER (NCT02003924): XTANDI versus Placebo in Non-metastatic CRPC Patients

PROSPER enrolled 1401 patients with non-metastatic CRPC, of whom 1395 received at least one dose of study drug. Patients were randomized 2:1 and received either XTANDI at a dose of 160 mg once daily (N = 930) or placebo (N = 465). The median duration of treatment at the time of analysis was 18.4 months (range: 0.0 to 42 months) with XTANDI and 11.1 months (range: 0.0 to 43 months) with placebo.

Overall, 32 patients (3.4%) receiving XTANDI died from adverse events. The reasons for death with ≥ 2 patients included coronary artery disorders (n = 7), sudden death (n = 2), cardiac arrhythmias (n = 2), general physical health deterioration (n = 2), stroke (n = 2), and secondary malignancy (n = 5; one each of acute myeloid leukemia, brain neoplasm,

mesothelioma, small cell lung cancer, and malignant neoplasm of unknown primary site). Three patients (0.6%) receiving placebo died from adverse events of cardiac arrest (n = 1), left ventricular failure (n = 1), and pancreatic carcinoma (n = 1). Grade 3 or higher adverse reactions were reported among 31% of XTANDI-treated patients and 23% of placebo-treated patients. Discontinuations with an adverse event as the primary reason were reported for 9.4% of XTANDI-treated patients and 6.0% of placebo-treated patients. Of these, the most common adverse event leading to treatment discontinuation was fatigue, which occurred in 1.6% of the XTANDI-treated patients compared to none of the placebo-treated patients. [Table 4](#) shows adverse reactions reported in PROSPER that occurred at a $\geq 2\%$ higher frequency in the XTANDI arm than in the placebo arm.

Table 4. Adverse Reactions in PROSPER

	XTANDI (N = 930)		Placebo (N = 465)	
	Grade 1-4 ¹ (%)	Grade 3-4 (%)	Grade 1-4 (%)	Grade 3-4 (%)
Metabolism and Nutrition Disorders				
Decreased Appetite	9.6	0.2	3.9	0.2
Nervous System Disorders				
Dizziness ²	12	0.5	5.2	0
Headache	9.1	0.2	4.5	0
Cognitive and Attention Disorders ³	4.6	0.1	1.5	0
Vascular Disorders				
Hot Flush	13	0.1	7.7	0
Hypertension	12	4.6	5.2	2.2
Gastrointestinal Disorders				
Nausea	11	0.3	8.6	0
Constipation	9.1	0.2	6.9	0.4
General Disorders and Administration Site Conditions				
Asthenic Conditions ⁴	40	4.0	20	0.9
Investigations				
Weight Decreased	5.9	0.2	1.5	0
Injury, Poisoning and Procedural Complications				
Fall	11	1.3	4.1	0.6
Fractures ⁵	9.8	2.0	4.9	1.7
Psychiatric Disorders				
Anxiety	2.8	0.2	0.4	0

1. CTCAE v 4
2. Includes dizziness and vertigo.
3. Includes amnesia, memory impairment, cognitive disorder, and disturbance in attention.
4. Includes asthenia and fatigue.
5. Includes all osseous fractures from all sites.

ARCHES (NCT02677896): XTANDI versus Placebo in Metastatic CSPC Patients

ARCHES randomized 1150 patients with mCSPC, of whom 1146 received at least one dose of study drug. All patients received either a gonadotropin-releasing hormone (GnRH) analogue concurrently or had bilateral orchiectomy. Patients received either XTANDI at a dose of 160 mg once daily (N=572) or placebo (N=574). The median duration of treatment was 12.8 months (range: 0.2 to 26.6 months) with XTANDI and 11.6 months (range: 0.2 to 24.6 months) with placebo.

Overall, 10 patients (1.7%) receiving XTANDI died from adverse events. The reasons for death in ≥ 2 patients included heart disease (n=3), sepsis (n=2) and pulmonary embolism (n=2). Eight patients (1.4%) receiving placebo died from adverse events. The reasons for death in ≥ 2 patients included heart disease (n=2) and sudden death (n=2). Grade 3 or higher adverse events were reported in 24% of patients treated with XTANDI. Permanent discontinuation due to adverse

events as the primary reason was reported in 4.9% of XTANDI-treated patients and 3.7% of placebo-treated patients. The most common adverse events resulting in permanent discontinuation in XTANDI-treated patients were alanine aminotransferase increased, aspartate aminotransferase elevation, and seizure, each in 0.3%. The most common adverse events leading to permanent discontinuation in placebo-treated patients were arthralgia, and fatigue, each in 0.3%.

Dose reductions due to an adverse reaction occurred in 4.4% of patients who received XTANDI. Fatigue/asthenia was the most frequent adverse reaction requiring dose reduction in 2.1% of XTANDI-treated patients and 0.7% of placebo-treated patients.

[Table 5](#) shows adverse reactions reported in ARCHES that occurred at a $\geq 2\%$ higher frequency in the XTANDI arm than in the placebo arm.

Table 5. Adverse Reactions in ARCHES

	XTANDI (N = 572)		Placebo (N = 574)	
	Grade 1-4 ¹ (%)	Grade 3-4 (%)	Grade 1-4 (%)	Grade 3-4 (%)
Metabolism and Nutrition Disorders				
Decreased Appetite	4.9	0.2	2.6	0
Nervous System Disorders				
Cognitive and Memory Impairment ²	4.5	0.7	2.1	0
Restless Legs Syndrome	2.4	0	0.3	0
Vascular Disorders				
Hot Flush	27	0.3	22	0
Hypertension	8.0	3.3	5.6	1.7
General Disorders and Administration Site Conditions				
Asthenic conditions ³	24	1.7	20	1.6
Musculoskeletal and Connective Tissue Disorders				
Musculoskeletal Pain	6.3	0.2	4.0	0.2
Injury, Poisoning and Procedural Complications				
Fractures ⁴	6.5	1.0	4.2	1.0

1. CTCAE v 4.03.

2. Includes memory impairment, amnesia, cognitive disorder, dementia, disturbance in attention, transient global amnesia, dementia alzheimer's type, mental impairment, senile dementia and vascular dementia.

3. Includes asthenia and fatigue.

4. Includes Fracture related preferred terms under high level terms: fractures NEC; fractures and dislocations NEC; limb fractures and dislocations; pelvic fractures and dislocations; skull and brain therapeutic procedures; skull fractures, facial bone fractures and dislocations; spinal fractures and dislocations; thoracic cage fractures and dislocations.

Laboratory Abnormalities

[Table 6](#) shows laboratory abnormalities that occurred in $\geq 5\%$ of patients, and more frequently ($> 2\%$) in the XTANDI arm compared to placebo in the pooled, randomized, placebo-controlled studies.

Table 6. Laboratory Abnormalities

	XTANDI (N = 3173)		Placebo (N = 2282)	
	Grade 1-4 (%)	Grade 3-4 (%)	Grade 1-4 (%)	Grade 3-4 (%)
Hematology				
Neutrophil count decreased	20	0.9	17	0.4
White blood cell decreased	17	0.4	9.8	0.2
Chemistry				

	XTANDI (N = 3173)		Placebo (N = 2282)	
	Grade 1-4 (%)	Grade 3-4 (%)	Grade 1-4 (%)	Grade 3-4 (%)
Hyperglycemia	83	3.2	75	3.1
Hypermagnesemia	16	0.1	13	0
Hyponatremia	13	1.4	8.6	1.5
Hypercalcemia	6.8	0.1	4.5	0

Hypertension

In the combined data from four randomized placebo-controlled clinical trials, hypertension was reported in 12% of patients receiving XTANDI and 5% of patients receiving placebo. Medical history of hypertension was balanced between arms. Hypertension led to study discontinuation in < 1% of patients in each arm.

6.2 Post-Marketing Experience

The following additional adverse reactions have been identified during post-approval use of XTANDI. Because these reactions are reported voluntarily from a population of uncertain size, it is not always possible to reliably estimate the frequency or establish a causal relationship to drug exposure.

Gastrointestinal Disorders: vomiting

Immune System Disorders: hypersensitivity (edema of the face, tongue, lip, or pharynx)

Neurological Disorders: posterior reversible encephalopathy syndrome (PRES)

Skin and Subcutaneous Tissue Disorders: rash, severe cutaneous adverse reactions (including Stevens-Johnson syndrome (SJS), erythema multiforme, toxic epidermal necrolysis (TEN), drug reaction with eosinophilia and systemic symptoms (DRESS) and acute generalized exanthematous pustulosis (AGEP))

7 DRUG INTERACTIONS

7.1 Drugs that Inhibit CYP2C8

Co-administration of a strong CYP2C8 inhibitor (gemfibrozil) increased the composite area under the plasma concentration-time curve (AUC) of enzalutamide plus N-desmethyl enzalutamide by 2.2-fold. Co-administration of XTANDI with strong CYP2C8 inhibitors should be avoided if possible. If co-administration of XTANDI with a strong CYP2C8 inhibitor cannot be avoided, reduce the dose of XTANDI [see [Dosage and Administration \(2.2\)](#) and [Clinical Pharmacology \(12.3\)](#)].

7.2 Drugs that Induce CYP3A4

Co-administration of rifampin (strong CYP3A4 inducer and moderate CYP2C8 inducer) decreased the composite AUC of enzalutamide plus N-desmethyl enzalutamide by 37%. Co-administration of strong CYP3A4 inducers (e.g., carbamazepine, phenobarbital, phenytoin, rifabutin, rifampin, rifapentine) with XTANDI should be avoided if possible. St John's wort may decrease enzalutamide exposure and should be avoided. If co-administration of a strong CYP3A4 inducer with XTANDI cannot be avoided, increase the dose of XTANDI [see [Dosage and Administration \(2.2\)](#) and [Clinical Pharmacology \(12.3\)](#)].

7.3 Effect of XTANDI on Drug Metabolizing Enzymes

Enzalutamide is a strong CYP3A4 inducer and a moderate CYP2C9 and CYP2C19 inducer in humans. At steady-state, XTANDI reduced the plasma exposure to midazolam (CYP3A4 substrate), warfarin (CYP2C9 substrate), and omeprazole

(CYP2C19 substrate). Concomitant use of XTANDI with narrow therapeutic index drugs that are metabolized by CYP3A4 (e.g., alfentanil, cyclosporine, dihydroergotamine, ergotamine, fentanyl, pimozide, quinidine, sirolimus and tacrolimus), CYP2C9 (e.g., phenytoin, warfarin) and CYP2C19 (e.g., S-mephenytoin, clopidogrel) should be avoided, as enzalutamide may decrease their exposure. If co-administration with warfarin cannot be avoided, conduct additional INR monitoring [see [Clinical Pharmacology \(12.3\)](#)].

8 USE IN SPECIFIC POPULATIONS

8.1 Pregnancy

Risk Summary

The safety and efficacy of XTANDI have not been established in females. Based on animal reproductive studies and mechanism of action, XTANDI can cause fetal harm and loss of pregnancy. There are no human data on the use of XTANDI in pregnant females. In animal reproduction studies, oral administration of enzalutamide in pregnant mice during organogenesis caused adverse developmental effects at doses lower than the maximum recommended human dose (*see Data*).

Data

Animal Data

In an embryo-fetal developmental toxicity study in mice, enzalutamide caused developmental toxicity when administered at oral doses of 10 or 30 mg/kg/day throughout the period of organogenesis (gestational days 6-15). Findings included embryo-fetal lethality (increased post-implantation loss and resorptions) and decreased anogenital distance at ≥ 10 mg/kg/day, and cleft palate and absent palatine bone at 30 mg/kg/day. Doses of 30 mg/kg/day caused maternal toxicity. The doses tested in mice (1, 10 and 30 mg/kg/day) resulted in systemic exposures (AUC) approximately 0.04, 0.4 and 1.1 times, respectively, the exposures in patients. Enzalutamide did not cause developmental toxicity in rabbits when administered throughout the period of organogenesis (gestational days 6-18) at dose levels up to 10 mg/kg/day (approximately 0.4 times the exposures in patients based on AUC).

In a pharmacokinetic study in pregnant rats with a single oral 30 mg/kg enzalutamide administration on gestation day 14, enzalutamide and/or its metabolites were present in the fetus at a C_{\max} that was approximately 0.3 times the concentration found in maternal plasma and occurred 4 hours after administration.

8.2 Lactation

Risk Summary

The safety and efficacy of XTANDI have not been established in females. There is no information available on the presence of XTANDI in human milk, the effects of the drug on the breastfed infant, or the effects of the drug on milk production. Enzalutamide and/or its metabolites were present in milk of lactating rats (*see Data*).

Data

Following a single oral administration in lactating rats on postnatal day 14, enzalutamide and/or its metabolites were present in milk at a C_{\max} that was 4 times higher than concentrations in the plasma and occurred 4 hours after administration.

8.3 Females and Males of Reproductive Potential

Contraception

Males

Based on findings in animal reproduction studies, advise male patients with female partners of reproductive potential to use effective contraception during treatment and for 3 months after the last dose of XTANDI [see [Use in Specific Populations \(8.1\)](#)].

Infertility

Males

Based on animal studies, XTANDI may impair fertility in males of reproductive potential [see [Nonclinical Toxicology \(13.1\)](#)].

8.4 Pediatric Use

Safety and effectiveness of XTANDI in pediatric patients have not been established.

8.5 Geriatric Use

Of 4081 patients who received XTANDI in seven randomized, controlled clinical trials, 78% were 65 and over, while 35% were 75 and over. No overall differences in safety or effectiveness were observed between these patients and younger patients. Other reported clinical experience has not identified differences in responses between the elderly and younger patients, but greater sensitivity of some older individuals cannot be ruled out.

8.6 Patients with Renal Impairment

A dedicated renal impairment trial for XTANDI has not been conducted. Based on the population pharmacokinetic analysis using data from clinical trials in patients with metastatic CRPC and healthy volunteers, no significant difference in enzalutamide clearance was observed in patients with pre-existing mild to moderate renal impairment (30 mL/min \leq creatinine clearance [CrCL] \leq 89 mL/min) compared to patients and volunteers with baseline normal renal function (CrCL \geq 90 mL/min). No initial dosage adjustment is necessary for patients with mild to moderate renal impairment. Severe renal impairment (CrCL < 30 mL/min) and end-stage renal disease have not been assessed [see [Clinical Pharmacology \(12.3\)](#)].

8.7 Patients with Hepatic Impairment

Dedicated hepatic impairment trials compared the composite systemic exposure of enzalutamide plus N-desmethyl enzalutamide in volunteers with baseline mild, moderate, or severe hepatic impairment (Child-Pugh Class A, B, or C, respectively) versus healthy controls with normal hepatic function. The composite AUC of enzalutamide plus N-desmethyl enzalutamide was similar in volunteers with mild, moderate, or severe baseline hepatic impairment compared to volunteers with normal hepatic function. No initial dosage adjustment is necessary for patients with baseline mild, moderate, or severe hepatic impairment [see [Clinical Pharmacology \(12.3\)](#)].

10 OVERDOSAGE

In the event of an overdose, stop treatment with XTANDI and initiate general supportive measures taking into consideration the half-life of 5.8 days. In a dose escalation study, no seizures were reported at \leq 240 mg daily, whereas 3 seizures were reported, 1 each at 360 mg, 480 mg, and 600 mg daily. Patients may be at increased risk of seizure following an overdose.

11 DESCRIPTION

Enzalutamide is an androgen receptor inhibitor. The chemical name is 4-{3-[4-cyano-3-(trifluoromethyl)phenyl]-5,5-dimethyl-4-oxo-2-sulfanylideneimidazolidin-1-yl}-2-fluoro-N-methylbenzamide.

The molecular weight is 464.44 and molecular formula is C₂₁H₁₆F₄N₄O₂S. The structural formula is:

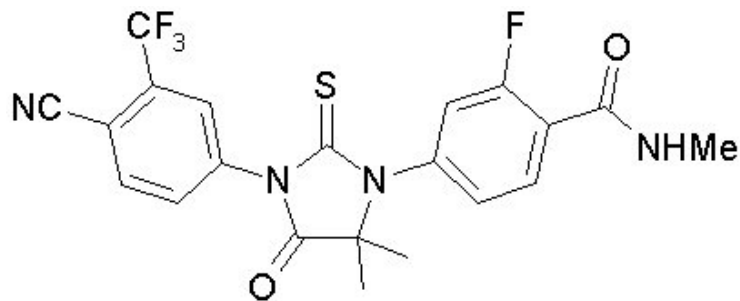

Enzalutamide is a white crystalline non-hygroscopic solid. It is practically insoluble in water.

XTANDI is available as liquid-filled soft gelatin capsules for oral administration. Each capsule contains 40 mg of enzalutamide as a solution in caprylocaproyl polyoxylglycerides. The inactive ingredients are caprylocaproyl polyoxylglycerides, butylated hydroxyanisole, butylated hydroxytoluene, gelatin, sorbitol sorbitan solution, glycerin, purified water, titanium dioxide, and black iron oxide.

XTANDI is also available as film-coated tablets for oral administration. Each tablet contains 40 mg or 80 mg of enzalutamide. The inactive ingredients are hypromellose acetate succinate, microcrystalline cellulose, colloidal silicon dioxide, croscarmellose sodium, and magnesium stearate. The tablet film-coat contains hypromellose, talc, polyethylene glycol, titanium dioxide, and ferric oxide.

12 CLINICAL PHARMACOLOGY

12.1 Mechanism of Action

Enzalutamide is an androgen receptor inhibitor that acts on different steps in the androgen receptor signaling pathway. Enzalutamide has been shown to competitively inhibit androgen binding to androgen receptors; and consequently, inhibits nuclear translocation of androgen receptors and their interaction with DNA. A major metabolite, N-desmethyl enzalutamide, exhibited similar *in vitro* activity to enzalutamide. Enzalutamide decreased proliferation and induced cell death of prostate cancer cells *in vitro*, and decreased tumor volume in a mouse prostate cancer xenograft model.

12.2 Pharmacodynamics

Cardiac Electrophysiology

The effect of enzalutamide 160 mg/day at steady-state on the QTc interval was evaluated in 796 patients with metastatic CRPC. No large difference (i.e., greater than 20 ms) was observed between the mean QT interval change from baseline in patients treated with XTANDI and that in patients treated with placebo, based on the Fridericia correction method. However, small increases in the mean QTc interval (i.e., less than 10 ms) due to enzalutamide cannot be excluded due to limitations of the study design.

12.3 Pharmacokinetics

The pharmacokinetics of enzalutamide and its major active metabolite (N-desmethyl enzalutamide) were evaluated in patients with metastatic CRPC and healthy male volunteers. The plasma enzalutamide pharmacokinetics are adequately described by a linear two-compartment model with first-order absorption.

Absorption

Following oral administration of XTANDI capsules (160 mg daily) in patients with metastatic CRPC, the median time to reach maximum plasma enzalutamide concentrations (C_{max}) is 1 hour (range 0.5 to 3 hours). At steady-state, the plasma mean C_{max} values for enzalutamide and N-desmethyl enzalutamide are 16.6 $\mu\text{g/mL}$ (23% CV) and 12.7 $\mu\text{g/mL}$ (30% CV), respectively, and the plasma mean predose trough values are 11.4 $\mu\text{g/mL}$ (26% CV) and 13.0 $\mu\text{g/mL}$ (30% CV),

respectively. Following a single dose administration of 160 mg enzalutamide in healthy male volunteers, enzalutamide extent of absorption (AUC) was comparable between XTANDI tablet and XTANDI capsule, but the mean C_{max} was 10%-28% lower than that of XTANDI capsules. The steady-state pharmacokinetic profiles (AUC and C_{max}) of enzalutamide and N-desmethyl enzalutamide are similar for XTANDI tablet and XTANDI capsule.

With the daily dosing regimen, enzalutamide steady-state is achieved by Day 28, and enzalutamide accumulates approximately 8.3-fold relative to a single dose. Daily fluctuations in enzalutamide plasma concentrations are low (mean peak-to-trough ratio of 1.25). At steady-state, enzalutamide showed approximately dose proportional pharmacokinetics over the daily dose range of 30 to 360 mg.

A single 160 mg oral dose of XTANDI was administered to healthy volunteers with a high-fat meal or in the fasted condition. A high-fat meal did not alter the AUC to enzalutamide or N-desmethyl enzalutamide. The results are summarized in [Figure 1](#).

Distribution and Protein Binding

The mean apparent volume of distribution (V/F) of enzalutamide in patients after a single oral dose is 110 L (29% CV).

Enzalutamide is 97% to 98% bound to plasma proteins, primarily albumin. N-desmethyl enzalutamide is 95% bound to plasma proteins. *In vitro*, there was no protein binding displacement between enzalutamide and other highly protein bound drugs (warfarin, ibuprofen, and salicylic acid) at clinically relevant concentrations.

Metabolism

Following single oral administration of ^{14}C -enzalutamide 160 mg, plasma samples were analyzed for enzalutamide and its metabolites up to 77 days post dose. Enzalutamide, N-desmethyl enzalutamide, and a major inactive carboxylic acid metabolite accounted for 88% of the ^{14}C -radioactivity in plasma, representing 30%, 49%, and 10%, respectively, of the total ^{14}C -AUC_{0-inf}.

In vitro, human CYP2C8 and CYP3A4 are responsible for the metabolism of enzalutamide. Based on *in vivo* and *in vitro* data, CYP2C8 is primarily responsible for the formation of the active metabolite (N-desmethyl enzalutamide). *In vitro* data suggest that carboxylesterase 1 metabolizes N-desmethyl enzalutamide and enzalutamide to the inactive carboxylic acid metabolite.

In vitro, N-desmethyl enzalutamide is not a substrate of human CYP1A1, CYP1A2, CYP2A6, CYP2B6, CYP2C8, CYP2C9, CYP2C18, CYP2C19, CYP2D6, CYP2E1 and CYP3A4/5.

Elimination

Enzalutamide is primarily eliminated by hepatic metabolism. Following single oral administration of ^{14}C -enzalutamide 160 mg, 85% of the radioactivity is recovered by 77 days post dose: 71% is recovered in urine (including only trace amounts of enzalutamide and N-desmethyl enzalutamide), and 14% is recovered in feces (0.4% of dose as unchanged enzalutamide and 1% as N-desmethyl enzalutamide).

The mean apparent clearance (CL/F) of enzalutamide in patients after a single oral dose is 0.56 L/h (range 0.33 to 1.02 L/h).

The mean terminal half-life ($t_{1/2}$) for enzalutamide in patients after a single oral dose is 5.8 days (range 2.8 to 10.2 days). Following a single 160 mg oral dose of enzalutamide in healthy volunteers, the mean terminal $t_{1/2}$ for N-desmethyl enzalutamide is approximately 7.8 to 8.6 days.

Pharmacokinetics in Special Populations

Renal Impairment:

A population pharmacokinetic analysis (based on pre-existing renal function) was carried out with data from 59 healthy male volunteers and 926 patients with metastatic CRPC enrolled in clinical trials, including 512 with normal renal function ($\text{CrCL} \geq 90 \text{ mL/min}$), 332 with mild renal impairment ($\text{CrCL} 60 \text{ to } < 90 \text{ mL/min}$), 88 with moderate renal impairment ($\text{CrCL} 30 \text{ to } < 60 \text{ mL/min}$), and 1 with severe renal impairment ($\text{CrCL} < 30 \text{ mL/min}$). The apparent clearance of enzalutamide was similar in patients with pre-existing mild and moderate renal impairment ($\text{CrCL} 30 \text{ to } < 90 \text{ mL/min}$) compared to patients and volunteers with normal renal function. The potential effect of severe renal impairment or end-stage renal disease on enzalutamide pharmacokinetics cannot be determined as clinical and pharmacokinetic data are available from only one patient [see [Use in Specific Populations \(8.6\)](#)].

Hepatic Impairment:

The plasma pharmacokinetics of enzalutamide and N-desmethyl enzalutamide were examined in volunteers with normal hepatic function ($N = 22$) and with pre-existing mild ($N = 8$, Child-Pugh Class A) moderate ($N = 8$, Child-Pugh Class B), or severe ($N = 8$, Child-Pugh Class C) hepatic impairment. XTANDI was administered as a single 160 mg dose. The composite AUC of enzalutamide plus N-desmethyl enzalutamide was similar in volunteers with mild, moderate, or severe baseline hepatic impairment compared to volunteers with normal hepatic function. The results are summarized in [Figure 1](#) [see [Use in Specific Populations \(8.7\)](#)].

Body Weight and Age:

Population pharmacokinetic analyses showed that weight (range: 46 to 163 kg) and age (range: 41 to 92 yr) do not have a clinically meaningful influence on the exposure to enzalutamide.

Gender:

The effect of gender on the pharmacokinetics of enzalutamide has not been evaluated.

Race:

The majority of XTANDI-treated patients in the randomized clinical trials were Caucasian (81%). Based on pharmacokinetic data from studies in Japanese and Chinese patients with prostate cancer, there were no clinically relevant differences in exposure among the populations. There are insufficient data to evaluate potential differences in the pharmacokinetics of enzalutamide in other races.

Drug Interactions

Effect of Other Drugs on XTANDI:

In a drug-drug interaction trial in healthy volunteers, a single 160 mg oral dose of XTANDI was administered alone or after multiple oral doses of gemfibrozil (strong CYP2C8 inhibitor). Gemfibrozil increased the $\text{AUC}_{0-\text{inf}}$ of enzalutamide plus N-desmethyl enzalutamide by 2.2-fold with minimal effect on C_{max} . The results are summarized in [Figure 1](#) [see [Dosage and Administration \(2.2\)](#) and [Drug Interactions \(7.1\)](#)].

In a drug-drug interaction trial in healthy volunteers, a single 160 mg oral dose of XTANDI was administered alone or after multiple oral doses of rifampin (strong CYP3A4 and moderate CYP2C8 inducer). Rifampin decreased the $\text{AUC}_{0-\text{inf}}$ of enzalutamide plus N-desmethyl enzalutamide by 37% with no effect on C_{max} . The results are summarized in [Figure 1](#) [see [Dosage and Administration \(2.2\)](#) and [Drug Interactions \(7.2\)](#)].

In a drug-drug interaction trial in healthy volunteers, a single 160 mg oral dose of XTANDI was administered alone or after multiple oral doses of itraconazole (strong CYP3A4 inhibitor). Itraconazole increased the $\text{AUC}_{0-\text{inf}}$ of enzalutamide plus N-desmethyl enzalutamide by 1.3-fold with no effect on C_{max} . The results are summarized in [Figure 1](#).

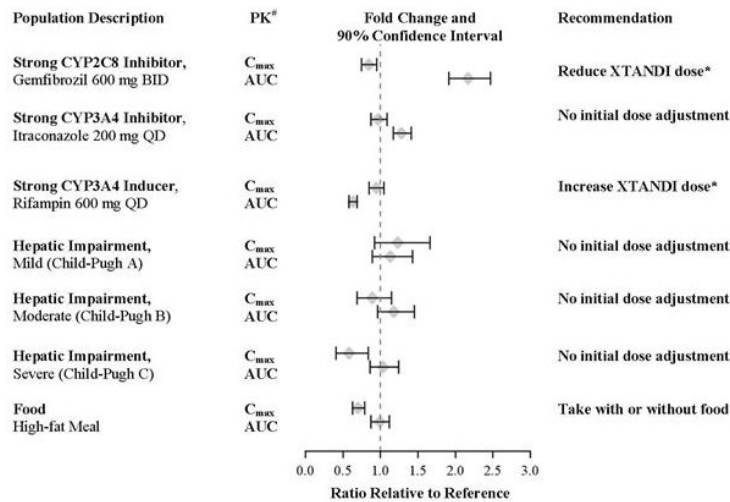

[#] PK parameters (C_{max} and AUC_{0-inf}) are for enzalutamide plus N-desmethyl enzalutamide, except in the food-effect trial, where they are for enzalutamide alone.

* See [Dosage and Administration \(2.2\)](#).

Figure 1. Effects of Other Drugs and Intrinsic/Extrinsic Factors on XTANDI

Effect of XTANDI on Other Drugs:

In an *in vivo* phenotypic cocktail drug-drug interaction trial in patients with metastatic CRPC, a single oral dose of the CYP probe substrate cocktail (for CYP2C8, CYP2C9, CYP2C19, and CYP3A4) was administered before and concomitantly with XTANDI (following at least 55 days of dosing at 160 mg daily). The results are summarized in [Figure 2](#). Results showed that *in vivo*, at steady-state, XTANDI is a strong CYP3A4 inducer and a moderate CYP2C9 and CYP2C19 inducer [see [Drug Interactions \(7.3\)](#)]. XTANDI did not cause clinically meaningful changes in exposure to the CYP2C8 substrate.

In an *in vivo* phenotypic cocktail drug-drug interaction trial in patients with CRPC, a single oral dose of the CYP probe substrate cocktail for CYP1A2 and CYP2D6 was administered before and concomitantly with XTANDI (following at least 49 days of dosing at 160 mg daily). The results are summarized in [Figure 2](#). Results showed that *in vivo*, at steady-state, XTANDI did not cause clinically meaningful changes in exposure to the CYP1A2 or CYP2D6 substrates.

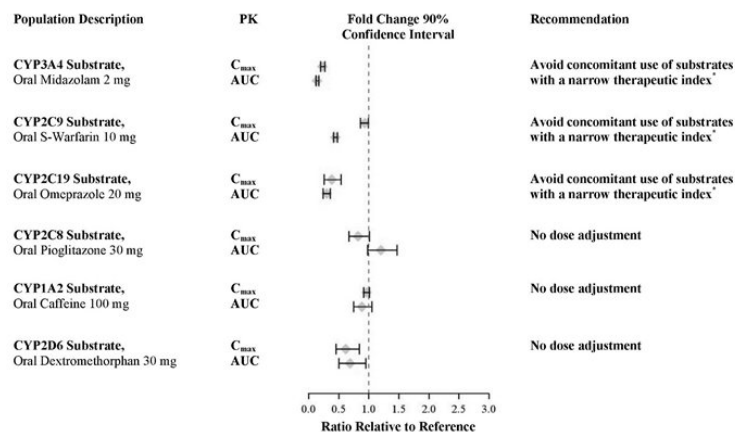

*See [Drug Interactions \(7.3\)](#).

Figure 2. Effect of XTANDI on Other Drugs

In vitro, enzalutamide, N-desmethyl enzalutamide, and the major inactive carboxylic acid metabolite caused direct inhibition of multiple CYP enzymes including CYP2B6, CYP2C8, CYP2C9, CYP2C19, CYP2D6, and CYP3A4/5; however, subsequent clinical data showed that XTANDI is an inducer of CYP2C9, CYP2C19, and CYP3A4 and had no clinically meaningful effect on CYP2C8 (see [Figure 2](#)). *In vitro*, enzalutamide caused time-dependent inhibition of CYP1A2.

In vitro studies showed that enzalutamide induces CYP2B6 and CYP3A4 and does not induce CYP1A2 at therapeutically relevant concentrations.

In vitro, enzalutamide, N-desmethyl enzalutamide, and the major inactive carboxylic acid metabolite are not substrates for human P-glycoprotein. *In vitro*, enzalutamide and N-desmethyl enzalutamide are inhibitors of human P-glycoprotein, while the major inactive carboxylic acid metabolite is not.

In vitro, enzalutamide and N-desmethyl enzalutamide do not appear to be substrates of human breast cancer resistance protein (BCRP); however, enzalutamide and N-desmethyl enzalutamide are inhibitors of human BCRP at clinically relevant concentrations.

13 NONCLINICAL TOXICOLOGY

13.1 Carcinogenesis, Mutagenesis, Impairment of Fertility

A two-year carcinogenicity study was conducted in male and female rats at oral enzalutamide doses of 10, 30, and 100 mg/kg/day. Enzalutamide increased the incidence of benign Leydig cell tumors in the testes at all dose levels tested (≥ 0.3 times the human exposure based on AUC) and combined incidence of urothelial papilloma and carcinoma in the urinary bladder in male rats at 100 mg/kg/day (1.4 times the human exposure based on AUC). The findings in the testes are considered to be related to the pharmacological activity of enzalutamide. Rats are regarded as more sensitive than humans to developing interstitial cell tumors in the testes. Administration of enzalutamide to male and female rasH2 transgenic mice by oral gavage daily for 26 weeks did not result in increased incidence of neoplasms at doses up to 20 mg/kg/day.

Enzalutamide did not induce mutations in the bacterial reverse mutation (Ames) assay and was not genotoxic in either the *in vitro* mouse lymphoma thymidine kinase (Tk) gene mutation assay or the *in vivo* mouse micronucleus assay.

Based on nonclinical findings in repeat-dose toxicology studies, which were consistent with the pharmacological activity of enzalutamide, male fertility may be impaired by treatment with XTANDI. In a 26-week study in rats, atrophy of the prostate and seminal vesicles was observed at ≥ 30 mg/kg/day (equal to the human exposure based on AUC). In 4-, 13-, and 39-week studies in dogs, hypospermatogenesis and atrophy of the prostate and epididymides were observed at ≥ 4 mg/kg/day (0.3 times the human exposure based on AUC).

14 CLINICAL STUDIES

The efficacy of XTANDI in patients with CRPC (N = 4692) or mCSPC (N = 1150) was demonstrated in five randomized, multicenter clinical trials. All patients received concomitant GnRH therapy or had prior bilateral orchiectomy. Patients were allowed, but not required, to continue or initiate glucocorticoids.

AFFIRM (NCT00974311): XTANDI versus Placebo in Metastatic CRPC Following Chemotherapy

In AFFIRM, a total of 1199 patients who had received prior docetaxel-based chemotherapy were randomized 2:1 to receive either XTANDI orally at a dose of 160 mg once daily (N = 800) or placebo orally once daily (N = 399). Study treatment continued until disease progression (evidence of radiographic progression, a skeletal-related event, or clinical progression), initiation of new systemic antineoplastic treatment, unacceptable toxicity, or withdrawal. Patients with a previous history of seizure, taking medicines known to decrease the seizure threshold, or with other risk factors for seizure were not eligible [see [Warnings and Precautions \(5.1\)](#)].

The following patient demographics and baseline disease characteristics were balanced between the treatment arms. The median age was 69 years (range 41-92) and the racial distribution was 92.7% Caucasian, 3.9% Black, 1.1% Asian, and 2.1% Other. Ninety-two percent of patients had an ECOG performance status score of 0-1 and 28% had a mean Brief Pain Inventory score of ≥ 4 . Ninety-one percent of patients had metastases in bone and 23% had visceral involvement in the lung and/or liver. Fifty-nine percent of patients had radiographic evidence of disease progression and 41% had PSA-only progression on study entry. All patients had received prior docetaxel-based therapy and 24% had received two cytotoxic chemotherapy regimens. During the trial, 48% of patients on the XTANDI arm and 46% of patients on the placebo arm received glucocorticoids.

A statistically significant improvement in overall survival was demonstrated at the pre-specified interim analysis at the time of 520 deaths in patients on the XTANDI arm compared to patients on the placebo arm (Table 7 and Figure 3).

Table 7. Overall Survival of Patients Treated with Either XTANDI or Placebo in AFFIRM

	XTANDI (N = 800)	Placebo (N = 399)
Number of Deaths (%)	308 (38.5)	212 (53.1)
Median Survival, months (95% CI)	18.4 (17.3, NR)	13.6 (11.3, 15.8)
P-value ¹	p < 0.0001	
Hazard Ratio (95% CI) ²	0.63 (0.53, 0.75)	

NR = Not reached.

1. P-value is derived from a log-rank test stratified by baseline ECOG performance status score (0-1 vs. 2) and mean baseline pain score (BPI-SF score < 4 vs. ≥ 4).
2. Hazard Ratio is derived from a stratified proportional hazards model. Hazard Ratio < 1 favors XTANDI.

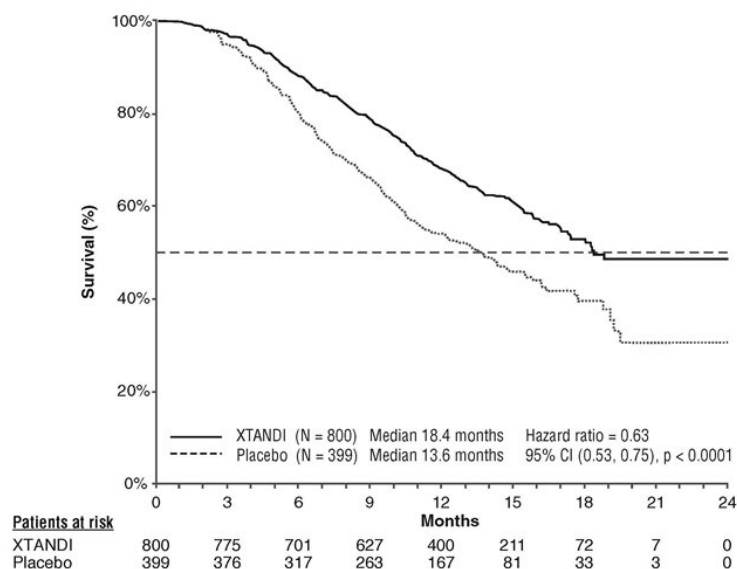

Figure 3. Kaplan-Meier Curves of Overall Survival in AFFIRM

PREVAIL (NCT01212991): XTANDI versus Placebo in Chemotherapy-naïve Metastatic CRPC

In PREVAIL, 1717 chemotherapy-naïve patients were randomized 1:1 to receive either XTANDI orally at a dose of 160 mg once daily (N = 872) or placebo orally once daily (N = 845). Patients with visceral metastases, patients with a history of mild to moderate heart failure (NYHA class I or II), and patients taking medications associated with lowering the seizure threshold were allowed. Patients with a previous history of seizure or a condition that might predispose to seizure and patients with moderate or severe pain from prostate cancer were excluded. Study treatment continued until disease progression (evidence of radiographic progression, a skeletal-related event, or clinical progression) and the initiation of a cytotoxic chemotherapy or an investigational agent, unacceptable toxicity, or withdrawal. Overall survival and radiographic progression-free survival (rPFS) were assessed. Radiographic progression was assessed with the use of

sequential imaging and was defined by bone scan identification of 2 or more new bone lesions with confirmation (Prostate Cancer Clinical Trials Working Group 2 criteria) and/or Response Evaluation Criteria in Solid Tumors (RECIST v 1.1) criteria for progression of soft tissue lesions. The primary analysis of rPFS utilized centrally reviewed radiographic assessment of progression.

Patient demographics and baseline disease characteristics were balanced between the treatment arms at entry. The median age was 71 years (range 42-93) and the racial distribution was 77% Caucasian, 10% Asian, 2% Black and 11% Other. The ECOG performance status score was 0 for 68% of patients, and 1 for 32% of patients. Baseline pain assessment was 0-1 (asymptomatic) in 67% of patients, and 2-3 (mildly symptomatic) in 32% of patients as defined by the Brief Pain Inventory Short Form (worst pain over past 24 hours at study entry). Fifty-four percent of patients had radiographic evidence of disease progression and 43% had PSA-only progression. Twelve percent of patients had visceral (lung and/or liver) disease involvement. During the study, 27% of patients on the XTANDI arm and 30% of patients on the placebo arm received glucocorticoids for varying reasons.

A statistically significant improvement in overall survival was demonstrated at the pre-specified interim analysis, conducted after 540 deaths, in patients treated with XTANDI compared to those treated with placebo (Table 8). Forty percent of XTANDI-treated and 70% of placebo-treated patients received subsequent therapies for metastatic CRPC that may prolong overall survival. An updated survival analysis was conducted when 784 deaths were observed. The median follow-up time was 31 months. Results from this analysis were consistent with those from the pre-specified interim analysis (Table 8, Figure 4). At the updated analysis, 52% of XTANDI-treated and 81% of placebo-treated patients had received subsequent therapies that may prolong overall survival in metastatic CRPC. XTANDI was used as a subsequent therapy in 2% of XTANDI-treated patients and 29% of placebo-treated patients.

Table 8. Overall Survival of Patients Treated with Either XTANDI or Placebo in PREVAIL

	XTANDI (N = 872)	Placebo (N = 845)
Pre-specified Interim Analysis¹		
Number of Deaths (%)	241 (28)	299 (35)
Median Survival, months (95% CI)	32.4 (30.1, NR)	30.2 (28.0, NR)
P-value ²	$p < 0.0001$	
Hazard Ratio (95% CI) ³	0.71 (0.60, 0.84)	
Updated Survival Analysis⁴		
Number of Deaths (%)	368 (42)	416 (49)
Median Survival, months (95% CI)	35.3 (32.2, NR)	31.3 (28.8, 34.2)
Hazard Ratio (95% CI) ³	0.77 (0.67, 0.88)	

NR = Not reached.

1. The data cutoff date is 16 Sep 2013.
2. P-value is derived from an unstratified log-rank test.
3. Hazard Ratio is derived from an unstratified proportional hazards model. Hazard Ratio < 1 favors XTANDI.
4. The data cutoff date is 1 Jun 2014. The planned number of deaths for the final overall survival analysis was ≥ 765 .

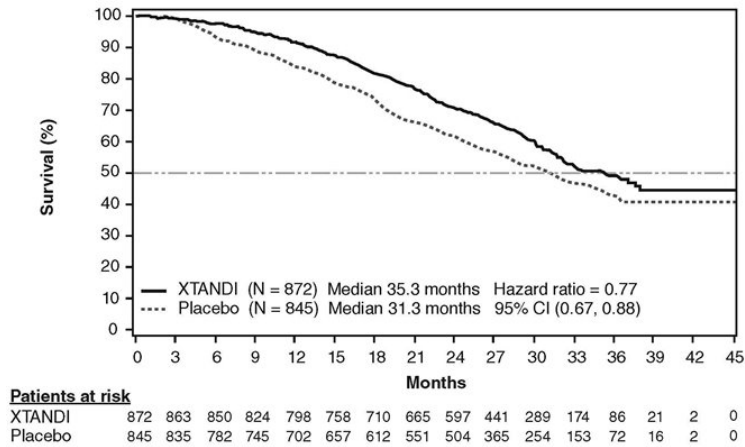

Figure 4. Kaplan-Meier Curves of Overall Survival in PREVAIL

A statistically significant improvement in rPFS was demonstrated in patients treated with XTANDI compared to patients treated with placebo (Table 9, Figure 5).

Table 9. Radiographic Progression-free Survival of Patients Treated with Either XTANDI or Placebo in PREVAIL

	XTANDI (N = 832)	Placebo (N = 801)
Number of Progression or Deaths (%)	118 (14)	320 (40)
Median rPFS (months) (95% CI)	NR (13.8, NR)	3.7 (3.6, 4.6)
P-value ¹	p < 0.0001	
Hazard Ratio (95% CI) ²	0.17 (0.14, 0.21)	

NR = Not reached.

Note: As of the cutoff date for the rPFS analysis, 1633 patients had been randomized.

1. P-value is derived from an unstratified log-rank test.
2. Hazard Ratio is derived from an unstratified proportional hazards model. Hazard Ratio < 1 favors XTANDI.

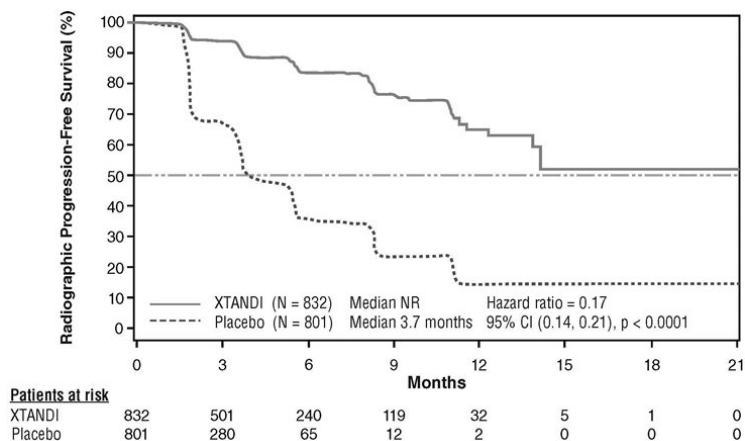

Figure 5. Kaplan-Meier Curves of Radiographic Progression-free Survival in PREVAIL

Time to initiation of cytotoxic chemotherapy was prolonged after XTANDI treatment, with a median of 28.0 months for patients on the XTANDI arm versus a median of 10.8 months for patients on the placebo arm [HR = 0.35 (95% CI: 0.30, 0.40), p < 0.0001].

The median time to first skeletal-related event was 31.1 months for patients on the XTANDI arm versus 31.3 months for patients on the placebo arm [HR = 0.72 (95% CI: 0.61, 0.84), p < 0.0001]. A skeletal-related event was defined as

radiation therapy or surgery to bone for prostate cancer, pathologic bone fracture, spinal cord compression, or change of antineoplastic therapy to treat bone pain.

TERRAIN (NCT01288911): XTANDI versus Bicalutamide in Chemotherapy-naïve Metastatic CRPC

TERRAIN was conducted in 375 chemotherapy-naïve patients who were randomized 1:1 to receive either XTANDI orally at a dose of 160 mg once daily (N = 184) or bicalutamide orally at a dose of 50 mg once daily (N = 191). Patients with a previous history of seizure or a condition that might predispose to seizure and patients with moderate to severe pain from prostate cancer were excluded. Patients could have received prior bicalutamide, but those whose disease had progressed on prior antiandrogen therapy (e.g., bicalutamide) were excluded. Study treatment continued until disease progression (evidence of radiographic progression, a skeletal-related event), the initiation of subsequent antineoplastic agent, unacceptable toxicity, or withdrawal. Radiographic disease progression was assessed by Independent Central Review (ICR) using the Prostate Cancer Clinical Trials Working Group 2 criteria and/or Response Evaluation Criteria in Solid Tumors (RECIST v 1.1) criteria for progression of soft tissue lesions. Radiographic progression-free survival (rPFS) was defined as the time from randomization to the first objective evidence of radiographic progression as assessed by ICR or death, whichever occurred first.

Patient demographics and baseline disease characteristics were balanced between the treatment arms at entry. The median age was 71 years (range 48-96) and the racial distribution was 93% Caucasian, 5% Black, 1% Asian and 1% Other. The ECOG performance status score was 0 for 74% of patients and 1 for 26% of patients. Baseline pain assessment was 0-1 (asymptomatic) in 58% of patients, and 2-3 (mildly symptomatic) in 36% of patients as defined by the Brief Pain Inventory Short Form Question 3 (worst pain over past 24 hours at study entry). Ninety-eight percent of patients had objective evidence of disease progression at study entry. Forty-six percent of patients had received prior treatment with bicalutamide while no patients received prior treatment with XTANDI.

An improvement in rPFS was demonstrated in patients treated with XTANDI compared to patients treated with bicalutamide (Table 10, Figure 6).

Table 10. Radiographic Progression-free Survival of Patients in TERRAIN

	XTANDI (N = 184)	Bicalutamide (N = 191)
Number of Progression or Deaths (%)	72 (39)	74 (39)
Median rPFS (months) (95% CI)	19.5 (11.8, NR)	13.4 (8.2, 16.4)
Hazard Ratio (95% CI) ¹	0.60 (0.43, 0.83)	

NR = Not reached.

1. Hazard Ratio is derived from an unstratified proportional hazards model. Hazard Ratio < 1 favors XTANDI

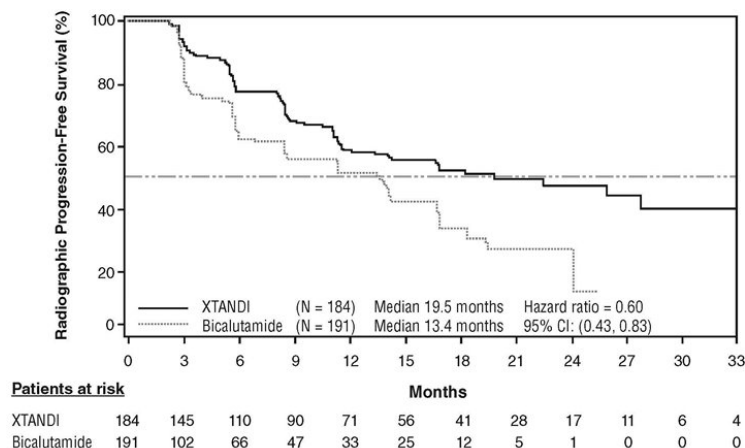

Figure 6. Kaplan-Meier Curves of Radiographic Progression-free Survival in TERRAIN

PROSPER (NCT02003924): XTANDI versus Placebo in Non-metastatic CRPC

PROSPER enrolled 1401 patients with non-metastatic CRPC who were randomized 2:1 to receive either XTANDI orally at a dose of 160 mg once daily (N = 933) or placebo orally once daily (N = 468). All patients in the PROSPER trial received a gonadotropin-releasing hormone (GnRH) analog or had a prior bilateral orchiectomy. Patients were stratified by Prostate Specific Antigen (PSA) Doubling Time (PSADT) and the use of bone-targeting agents. Patients were required to have a PSA doubling time ≤ 10 months, PSA ≥ 2 ng/mL, and confirmation of non-metastatic disease by blinded independent central review (BICR). PSA results were blinded and were not used for treatment discontinuation. Patients randomized to either arm discontinued treatment for radiographic disease progression confirmed by BICR, initiation of new treatment, unacceptable toxicity, or withdrawal.

The following patient demographics and baseline characteristics were balanced between the two treatment arms. The median age at randomization was 74 years (range 50-95) and 23% were 80 years of age or older. The racial distribution was 71% Caucasian, 16% Asian, and 2% Black. A majority of patients had a Gleason score of 7 or higher (77%). The median PSADT was 3.7 months. Fifty-four percent (54%) of patients received prior treatment for prostate cancer with either surgery or radiation. Sixty-three percent (63%) of patients received prior treatment with an anti-androgen; 56% of patients received bicalutamide and 11% of patients received flutamide. All patients had an Eastern Cooperative Oncology Group Performance Status (ECOG PS) score of 0 or 1 at study entry.

The major efficacy outcome of the study was metastasis-free survival (MFS), defined as the time from randomization to whichever of the following occurred first 1) loco-regional and/or distant radiographic progression per BICR or 2) death up to 112 days after treatment discontinuation without evidence of radiographic progression. A statistically significant improvement in MFS and OS was demonstrated in patients randomized to receive XTANDI compared with patients randomized to receive placebo. Consistent MFS results were observed when considering only distant radiographic progression events or deaths regardless of the cut-off date. Consistent MFS results were also observed in pre-specified and stratified patient sub-groups of PSADT (< 6 months or ≥ 6 months) and use of a prior bone-targeting agent (yes or no). The efficacy results from PROSPER are summarized in [Table 11](#), [Figure 7](#) and [Figure 8](#).

Table 11. Summary of Efficacy Results in PROSPER (Intent-to-treat Population)

	XTANDI (N = 933)	Placebo (N = 468)
Metastasis-free survival		
Number of Events (%)	219 (23.5)	228 (48.7)
Median, months (95% CI) ¹	36.6 (33.1, NR)	14.7 (14.2, 15.0)
Hazard Ratio (95% CI) ²	0.29 (0.24, 0.35)	
P-value ²	p < 0.0001	
Overall survival³		
Number of Events (%)	288 (30.9)	178 (38.0)
Median, months (95% CI) ¹	67.0 (64.0, NR)	56.3 (54.4, 63.0)
Hazard Ratio (95% CI) ²	0.73 (0.61, 0.88)	
P-value ²	p = 0.0011	

NR = Not reached.

1. Based on Kaplan-Meier estimates.
2. Hazard ratio from a Cox regression model (with treatment as the only covariate) and p-value from a log-rank test are stratified by PSA doubling time and prior or concurrent use of a bone targeting agent.
3. The pre-specified final analysis of OS occurred 27 months after the MFS analysis.

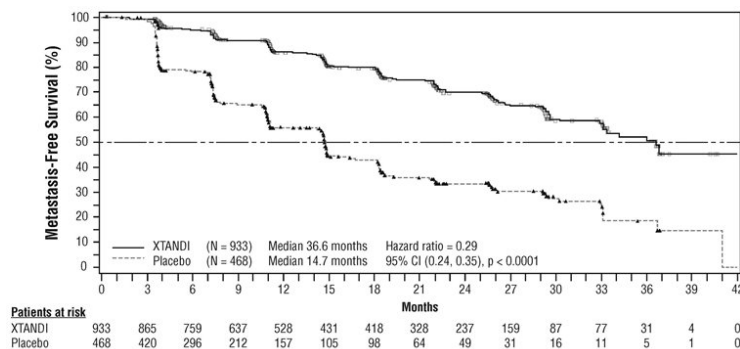

Figure 7. Kaplan-Meier Curves of Metastasis-free Survival in PROSPER

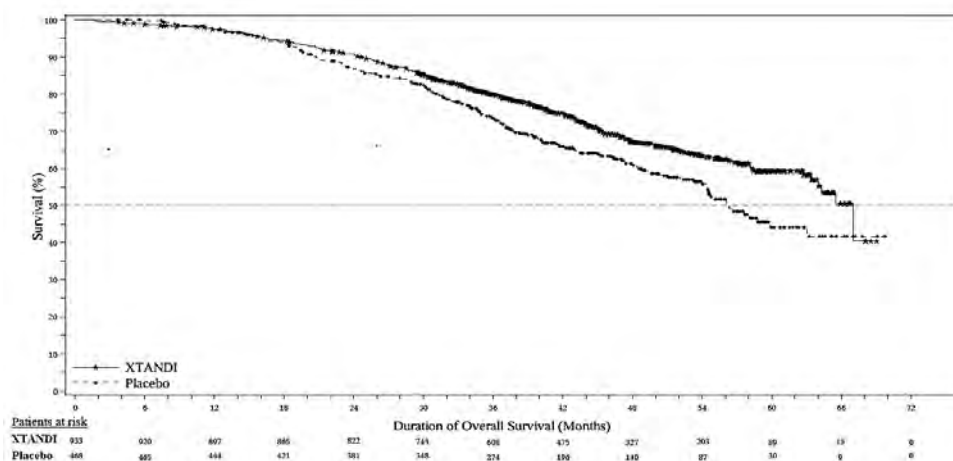

Figure 8. Kaplan-Meier Curves of Overall Survival in PROSPER

The primary efficacy outcome was also supported by a statistically significant delay in time to first use of new antineoplastic therapy (TTA) for patients in the XTANDI arm compared to those in the placebo arm. The median TTA was 39.6 months for patients on XTANDI and was 17.7 months for patients on placebo (HR = 0.21; 95% CI: [0.17, 0.26], $p < 0.0001$).

ARCHES (NCT02677896): XTANDI versus Placebo in Metastatic CSPC

ARCHES enrolled 1150 patients with mCSPC who were randomized 1:1 to receive XTANDI orally at a dose of 160 mg once daily (N=574) or placebo orally once daily (N=576). All patients in the trial received a GnRH analog or had a prior bilateral orchiectomy. Patients were stratified by volume of disease (low vs high) and prior docetaxel therapy for prostate cancer (no prior docetaxel, 1-5 cycles, or 6 prior cycles). High volume of disease is defined as metastases involving the viscera or, in the absence of visceral lesions, there must be 4 or more bone lesions, at least 1 of which must be in a bony structure beyond the vertebral column and pelvic bone. Treatment with concurrent docetaxel was not allowed. Patients continued treatment until radiographic disease progression, initiation of new treatment, unacceptable toxicity, or withdrawal.

The following patient demographics and baseline characteristics were balanced between the two treatment arms. The median age at randomization was 70 years (range: 42-92) and 30% were 75 years of age or older. The racial distribution was 81% Caucasian, 14% Asian, and 1% Black. Sixty-six percent (66%) of patients had a Gleason score of ≥ 8 . Thirty-seven percent (37%) of patients had a low volume of disease and 63% of patients had a high volume of disease. Eighty-

two percent (82%) of patients had no prior docetaxel treatment; 2% of patients had 1 to 5 cycles of docetaxel and 16% of patients had 6 prior cycles of docetaxel treatment. Twelve percent (12%) of patients received concomitant bone-targeted agents (bisphosphonates or RANKL inhibitors) which included both prostate and non-prostate cancer indications. The Eastern Cooperative Oncology Group Performance Status (ECOG PS) score was 0 for 78% of patients and 1 for 22% of patients at study entry.

The major efficacy outcome measure was radiographic progression-free survival (rPFS) based on blinded independent central review (BICR). Radiographic progression-free survival was defined as the time from randomization to radiographic disease progression at any time or death within 24 weeks after study drug discontinuation. Radiographic disease progression was defined by identification of 2 or more new bone lesions on a bone scan with confirmation (Prostate Cancer Working Group 2 criteria) and/or progression in soft tissue disease. Time to new antineoplastic therapy was an additional efficacy endpoint.

XTANDI demonstrated a statistically significant improvement in rPFS compared to placebo. Consistent rPFS results were observed in patients with high or low volume of disease and patients with and without prior docetaxel therapy. Overall survival (OS) data were not mature at the time of rPFS analysis (7.3% deaths in the ITT population had been reported). Efficacy results for rPFS from ARCHES are summarized in [Table 12](#) and [Figure 9](#).

Table 12. Efficacy Results in ARCHES based on BICR (Intent-to-Treat Analysis)

	XTANDI (N = 574)	Placebo (N=576)
Radiographic Progression-free Survival		
Number of events (%)	89 (15.5)	198 (34.4)
Radiographic disease progression	77 (13.4)	185 (32.1)
Death within 24 weeks after treatment discontinuation	12 (2.1)	13 (2.3)
Median, months (95% CI) ¹	NR	19.4 (16.6, NR)
Hazard ratio (95% CI) ²	0.39 (0.30, 0.50)	
P-value ³	p < 0.0001	

NR = Not reached

1. Based on Kaplan-Meier estimates.
2. Hazard Ratio is based on a Cox regression model stratified by volume of disease (low vs high) and prior docetaxel use (yes vs no).
3. P-value is based on a stratified log-rank test by volume of disease (low vs high) and prior docetaxel use (yes or no).

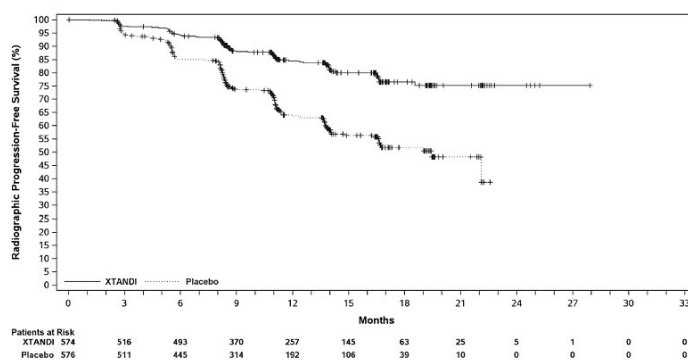

Figure 9. Kaplan-Meier Curves of rPFS in ARCHES (Intent-to-Treat Analysis)

A statistically significant improvement was also reported on the XTANDI arm compared to placebo in time to initiation of a new antineoplastic therapy (HR = 0.28 [95% CI: 0.20, 0.40]; p < 0.0001).

16 HOW SUPPLIED/STORAGE AND HANDLING

XTANDI (enzalutamide) 40 mg capsules are supplied as white to off-white oblong soft gelatin capsules imprinted in black ink with ENZ and are available in the following package size:

- Bottles of 120 capsules with child resistant closures (NDC 0469-0125-99)

XTANDI (enzalutamide) 40 mg tablets are supplied as yellow, round, film-coated tablets debossed with E 40, and are available in the following package size:

- Bottles of 120 tablets with child resistant closures (NDC 0469-0625-99)

XTANDI (enzalutamide) 80 mg tablets are supplied as yellow, oval, film-coated tablets debossed with E 80, and are available in the following package size:

- Bottles of 60 tablets with child resistant closures (NDC 0469-0725-60)

Recommended storage: Store XTANDI capsules and tablets at 20°C to 25°C (68°F to 77°F) in a dry place and keep the container tightly closed. Excursions permitted from 15°C to 30°C (59°F to 86°F).

Swallow capsules or tablets whole. Do not chew, dissolve or open the capsules. Do not cut, crush, or chew the tablets.

17 PATIENT COUNSELING INFORMATION

Advise the patient to read the FDA-approved patient labeling (Patient Information).

Seizure

- Inform patients that XTANDI has been associated with an increased risk of seizure. Discuss conditions that may predispose to seizures and medications that may lower the seizure threshold. Advise patients of the risk of engaging in any activity where sudden loss of consciousness could cause serious harm to themselves or others. Inform patients to contact their healthcare provider right away if they have loss of consciousness or seizure [*see [Warnings and Precautions \(5.1\)](#)*].

Posterior Reversible Encephalopathy Syndrome (PRES)

- Inform patients to contact their healthcare provider right away if they experience rapidly worsening symptoms possibly indicative of PRES such as seizure, headache, decreased alertness, confusion, reduced eyesight, or blurred vision [*see [Warnings and Precautions \(5.2\)](#)*].

Hypersensitivity

- Inform patients that XTANDI may be associated with hypersensitivity reactions that include swelling of the face, lip, tongue, or throat [*see [Warnings and Precautions \(5.3\)](#)*]. Advise patients who experience these types of symptoms of hypersensitivity to discontinue XTANDI and promptly contact their healthcare provider.

Ischemic Heart Disease

- Inform patients that XTANDI has been associated with an increased risk of ischemic heart disease. Advise patients to seek immediate medical attention if any symptoms suggestive of a cardiovascular event occur [*see [Warnings and Precautions \(5.4\)](#)*].

Falls and Fractures

- Inform patients that XTANDI is associated with an increased incidence of dizziness/vertigo, falls, and fractures. Advise patients to report these adverse reactions to their healthcare provider [*see [Warnings and Precautions \(5.5\)](#)*].

Hypertension

- Inform patients that XTANDI is associated with an increased incidence of hypertension [*see [Adverse Reactions \(6.1\)](#)*].

Dosing and Administration

- Inform patients who have not undergone bilateral orchiectomy and are receiving GnRH therapy that they need to maintain this treatment during the course of treatment with XTANDI.
- Instruct patients to take their dose at the same time each day (once daily). XTANDI can be taken with or without food. Each capsule or tablet should be swallowed whole. Do not chew, dissolve, or open the capsules. Do not cut, crush, or chew the tablets.
- Inform patients that they should not interrupt, modify the dose, or stop XTANDI without first consulting their healthcare provider.
- Inform patients that if they miss a dose, then they should take it as soon as they remember. If they forget to take the dose for the whole day, then they should take their normal dose the next day. They should not take more than their prescribed dose per day [*see [Dosage and Administration \(2.1\)](#)*].

Embryo-Fetal Toxicity

- Inform patients that XTANDI can be harmful to a developing fetus and can cause loss of pregnancy.
- Advise male patients with female partners of reproductive potential to use effective contraception during treatment and for 3 months after the last dose of XTANDI. Advise male patients to use a condom if having sex with a pregnant woman [*see [Warnings and Precautions \(5.6\)](#)*].

Infertility

- Inform male patients that XTANDI may impair fertility [*see [Use in Specific Populations \(8.3\)](#)*].

Manufactured for and Distributed by: Astellas Pharma US, Inc., Northbrook, IL 60062

Marketed by:

Astellas Pharma US, Inc., Northbrook, IL 60062 Pfizer Inc., New York, NY 10017
280168-XTA-USA

Rx Only

© 2020 Astellas Pharma US, Inc.

XTANDI® is a registered trademark of Astellas Pharma Inc.

PATIENT INFORMATION
XTANDI® (ex TAN dee)
(enzalutamide)
capsules and tablets

What is XTANDI®?

XTANDI is a prescription medicine used to treat men with prostate cancer that:

- no longer responds to a hormone therapy or surgical treatment to lower testosterone
OR
- has spread to other parts of the body and responds to a hormone therapy or surgical treatment to lower testosterone.

It is not known if XTANDI is safe and effective in females.

It is not known if XTANDI is safe and effective in children.

Before taking XTANDI, tell your healthcare provider about all your medical conditions, including if you:

- have a history of seizures, brain injury, stroke, or brain tumors.
- have a history of heart disease.
- have high blood pressure.
- have abnormal amounts of fat or cholesterol in your blood (dyslipidemia).
- are pregnant or plan to become pregnant. XTANDI can cause harm to your unborn baby and loss of pregnancy (miscarriage).
- have a partner who is pregnant or may become pregnant.
 - Males who have female partners who are able to become pregnant should use effective birth control (contraception) during treatment with XTANDI and for 3 months after the last dose of XTANDI.
 - Males must use a condom during sex with a pregnant female.
- are breastfeeding or plan to breastfeed. It is not known if XTANDI passes into your breast milk.

Tell your healthcare provider about all the medicines you take, including prescription and over-the-counter medicines, vitamins, and herbal supplements. XTANDI may affect the way other medicines work, and other medicines may affect how XTANDI works.

You should not start or stop any medicine before you talk with the healthcare provider that prescribed XTANDI.

Know the medicines you take. Keep a list of them with you to show your healthcare provider and pharmacist when you get a new medicine.

How should I take XTANDI?

- Take XTANDI exactly as your healthcare provider tells you.
- Take your prescribed dose of XTANDI 1 time a day, at the same time each day.
- Your healthcare provider may change your dose if needed.
- Do not change or stop taking your prescribed dose of XTANDI without talking with your healthcare provider first.
- XTANDI can be taken with or without food.
- Swallow XTANDI capsules or tablets whole. Do not chew, dissolve, or open the capsules. Do not cut, crush, or chew the tablets.
- If you are receiving gonadotropin-releasing hormone (GnRH) therapy, you should continue with this treatment during your treatment with XTANDI unless you have had a surgery to lower the amount of testosterone in your body (surgical castration).
- If you miss a dose of XTANDI, take your prescribed dose as soon as you remember that day. If you miss your daily dose, take your prescribed dose at your regular time the next day. Do not take more than your prescribed dose of XTANDI each day.

If you take too much XTANDI, call your healthcare provider or go to the nearest emergency room right away. You may have an increased risk of seizure if you take too much XTANDI.

What are the possible side effects of XTANDI?

XTANDI may cause serious side effects including:

- **Seizure.** If you take XTANDI you may be at risk of having a seizure. You should avoid activities where a sudden loss of consciousness could cause serious harm to yourself or others. Tell your healthcare provider right away if you have loss of consciousness or seizure.
- **Posterior Reversible Encephalopathy Syndrome (PRES).** If you take XTANDI you may be at risk of developing a condition involving the brain called PRES. Tell your healthcare provider right away if you have a seizure or quickly worsening symptoms such as headache, decreased alertness, confusion, reduced eyesight, blurred vision or other visual problems. Your healthcare provider will do a test to check for PRES.
- **Allergic Reactions.** Allergic reactions have happened in people who take XTANDI. Stop taking XTANDI and get medical help right away if you develop swelling of the face, tongue, lip or throat.
- **Heart disease.** Blockage of the arteries in the heart (ischemic heart disease) that can lead to death has happened in some people during treatment with XTANDI. Your healthcare provider will monitor you for signs and symptoms of heart problems during your treatment with XTANDI. Call your healthcare provider or go to the nearest emergency room right away if you get chest pain or discomfort at rest or with activity or shortness of breath during your treatment with XTANDI.
- **Falls and fractures.** XTANDI treatment may increase your risk for falls and fractures. Falls were not caused by loss of consciousness (fainting) or seizures. Your healthcare provider will monitor your risks for falls and fractures during treatment with XTANDI.

Your healthcare provider will stop treatment with XTANDI if you have serious side effects.

The most common side effects of XTANDI include:

- weakness or feeling more tired than usual
- back pain
- hot flashes
- constipation
- joint pain
- decreased appetite
- diarrhea
- high blood pressure

XTANDI may cause fertility problems in males, which may affect the ability to father children. Talk to your healthcare provider if you have concerns about fertility.

These are not all the possible side effects of XTANDI. Call your doctor for medical advice about side effects. You may report side effects to FDA at 1-800-FDA-1088.

How should I store XTANDI?

- XTANDI capsules and tablets come in a child-resistant bottle.
- Store XTANDI capsules and tablets between 68°F to 77°F (20°C to 25°C).
- Keep XTANDI capsules and tablets dry and in a tightly closed container.

Keep XTANDI and all medicines out of the reach of children.

General information about the safe and effective use of XTANDI.

Medicines are sometimes prescribed for purposes other than those listed in a Patient Information leaflet. Do not use XTANDI for a condition for which it was not prescribed. Do not give XTANDI to other people, even if they have the same symptoms that you have. It may harm them. You can ask your healthcare provider or pharmacist for information about XTANDI that is written for health professionals.

What are the ingredients in XTANDI?

XTANDI capsules

Active ingredient: enzalutamide

Inactive ingredients: caprylocaproyl polyoxyglycerides, butylated hydroxyanisole, butylated hydroxytoluene, gelatin, sorbitol sorbitan solution, glycerin, purified water, titanium dioxide, black iron oxide.

XTANDI tablets

Active ingredient: enzalutamide

Inactive ingredients: hypromellose acetate succinate, microcrystalline cellulose, colloidal silicon dioxide, croscarmellose sodium, and magnesium stearate.

The tablet film-coat contains hypromellose, talc, polyethylene glycol, titanium dioxide, and ferric oxide.

Manufactured for and Distributed by: Astellas Pharma US, Inc., Northbrook, IL 60062
Marketed by: Astellas Pharma US, Inc., Northbrook, IL 60062 Pfizer Inc., New York, NY 10017
280168-XTA-USA
© 2020 Astellas Pharma US, Inc.
XTANDI® is a registered trademark of Astellas Pharma Inc.
For more information go to www.Xtandi.com or call 1-800-727-7003.

This Patient Information has been approved by the U.S. Food and Drug Administration.

Revised: Oct 2020

PRODUCT MONOGRAPH

PrZAXINE

Rifaximin

550 mg tablets

Antibacterial agent

WHO ATC A07AA11

Manufactured by:

Salix Pharmaceuticals, Inc.
400 Somerset Corporate Boulevard
Bridgewater, NJ 08807 USA

Date of Preparation:

August 7, 2013

Date of Revision:

February 11, 2019

Distributed by:

Lupin Pharma Canada Ltd.
1001 Boul. Maisonneuve Est
Suite 304,
Montreal, Quebec H2L 4P9
Canada

Submission Control No: 216973

Table of Contents

PART I: HEALTH PROFESSIONAL INFORMATION.....	3
SUMMARY PRODUCT INFORMATION	3
INDICATIONS AND CLINICAL USE.....	3
CONTRAINDICATIONS	4
WARNINGS AND PRECAUTIONS.....	4
ADVERSE REACTIONS.....	6
DRUG INTERACTIONS	13
DOSAGE AND ADMINISTRATION.....	15
OVERDOSAGE	16
ACTION AND CLINICAL PHARMACOLOGY	16
STORAGE AND STABILITY.....	19
DOSAGE FORMS, COMPOSITION AND PACKAGING	19
PART II: SCIENTIFIC INFORMATION	20
PHARMACEUTICAL INFORMATION.....	20
CLINICAL TRIALS.....	21
DETAILED PHARMACOLOGY	28
MICROBIOLOGY	29
TOXICOLOGY	29
REFERENCES	31
PART III: CONSUMER INFORMATION.....	36

PrZAXINE

Rifaximin

PART I: HEALTH PROFESSIONAL INFORMATION

SUMMARY PRODUCT INFORMATION

Route of Administration	Dosage Form / Strength	Clinically Relevant Nonmedicinal Ingredients
Oral	550 mg tablet	None <i>For a complete listing see Dosage Forms, Composition and Packaging section.</i>

INDICATIONS AND CLINICAL USE

Hepatic Encephalopathy

ZAXINE[®] (rifaximin) is indicated for the reduction in risk of overt hepatic encephalopathy (HE) recurrence in patients \geq 18 years of age.

In the trials of ZAXINE for HE, 91% of the patients were treated with lactulose concomitantly or were on lactulose treatment concomitantly. Differences in the treatment effect on those patients not using lactulose concomitantly could not be assessed.

ZAXINE has not been studied in patients with MELD (Model for End-Stage Liver Disease) scores $>$ 25, and only 8.6% of patients in the controlled trial had MELD scores over 19. There is increased systemic exposure to rifaximin in patients with hepatic dysfunction.

To reduce the development of drug-resistant bacteria and maintain the effectiveness of rifaximin, ZAXINE should only be used for the authorized indication and clinical use.

Irritable Bowel Syndrome with Diarrhea

ZAXINE is indicated for the treatment of irritable bowel syndrome with diarrhea (IBS-D) in adults.

In the trials of ZAXINE for IBS-D, patients who experienced a recurrence of symptoms and who responded to a first treatment were safely and effectively retreated for up to 2 times. Current clinical trials have not evaluated the safety and efficacy of three or more repeat treatments for IBS-D. **Geriatrics ($>$ 65 years of age):**

Studies specifically designed to determine the dose in elderly patients have not been performed. In the controlled trial with ZAXINE, 19.4% were aged 65 years and over, while 2.3% were 75 and over. No overall differences in safety or effectiveness were observed between these

subjects and younger subjects, and other reported clinical experience has not identified differences in responses between the elderly and younger patients, but greater sensitivity of some older individuals cannot be ruled out.

Pediatrics (< 18 years of age):

The safety and effectiveness of ZAXINE in the prevention of overt hepatic encephalopathy (HE) recurrence or treatment of irritable bowel syndrome with diarrhea (IBS-D) has not been investigated in children and adolescents under 18 years of age.

CONTRAINDICATIONS

ZAXINE (rifaximin) is contraindicated in patients with a hypersensitivity to rifaximin, any of the rifamycin antimicrobial agents, or any of the ingredients in ZAXINE (See **DOSAGE FORMS, COMPOSITION AND PACKAGING** for a complete listing. See also **WARNINGS AND PRECAUTIONS – Immune**, and **ADVERSE REACTIONS**).

WARNINGS AND PRECAUTIONS

General

Not for Systemic Infections

ZAXINE (rifaximin) acts locally on the microflora of the gut and should not be used for the treatment of systemic bacterial infections.

Low systemic absorption of rifaximin has been noted in healthy individuals, but absorption is increased in subjects with impaired hepatic function. (See **WARNINGS AND PRECAUTIONS, Hepatic/Biliary/Pancreatic**). There is the potential for increased systemic exposure to rifaximin in disease states in which intestinal barrier function or gut motility is altered. Rifaximin exposure is slightly higher in patients with inflammatory bowel disease (2.3- and 4.3-fold increases in C_{max} and AUC, respectively) or irritable bowel syndrome (1.8- and 1.7-fold increases in C_{max} and AUC, respectively) than in healthy subjects receiving the same doses.

The effect on the gut flora following long-term use of rifaximin is not known.

Susceptibility/Resistance

Development of Drug Resistant Bacteria

Prescribing ZAXINE in the absence of the authorized indications is unlikely to provide benefit to the patient and risks the development of drug-resistant bacteria.

Carcinogenicity

A possible relationship between Zaxine treatment and carcinogenicity cannot be ruled out. A 2-year rat study with administration of rifaximin alfa- at doses of 150 to 250 mg/kg/day (doses equivalent to 1.3 to 2.2 times the recommended human dose, based on relative body surface area

comparisons) showed an increased trend in malignant schwannomas of the heart in male rats, but not female rats. (See **TOXICOLOGY, Carcinogenicity**).

Gastrointestinal

Clostridium difficile-Associated Disease

Clostridium difficile-associated disease (CDAD) has been reported with use of nearly all antibacterial agents, including ZAXINE (see **ADVERSE REACTIONS**), and may range in severity from mild diarrhea to fatal colitis. Treatment with antibacterial agents alters the normal flora of the colon which may lead to overgrowth of *C. difficile*.

C. difficile produces toxins A and B which contribute to the development of CDAD. Hypertoxin producing strains of *C. difficile* cause increased morbidity and mortality, as these infections can be refractory to antimicrobial therapy and may require colectomy. CDAD must be considered in all patients who present with diarrhea following antibiotic use. Careful medical history is necessary since CDAD has been reported to occur over two months after the administration of antibacterial agents.

If CDAD is suspected or confirmed, ongoing antibiotic use not directed against *C. difficile* may need to be discontinued. Appropriate fluid and electrolyte management, protein supplementation, antibiotic treatment of *C. difficile*, and surgical evaluation should be instituted as clinically indicated.

Intestinal Obstruction

Zaxine has not been studied for use in prevention of hepatic encephalopathy or treatment of IBS-D in patients with intestinal obstruction; use in patients with an intestinal obstruction is not recommended.

Hepatic/Biliary/Pancreatic

Following administration of ZAXINE 550 mg twice daily to patients with a history of hepatic encephalopathy, the systemic exposure to rifaximin was increased with increasing hepatic impairment. The AUC_{tau} was about 10-, 13-, and 20-fold higher in those patients with mild (Child-Pugh A), moderate (Child-Pugh B) and severe (Child-Pugh C) hepatic impairment, respectively, compared to that in healthy subjects (see **ACTION AND CLINICAL PHARMACOLOGY, Pharmacokinetics**). The highest systemic exposure to rifaximin was seen in patients with severe hepatic impairment. Additionally, the clinical trials were limited to patients with MELD scores <25. Therefore, caution should be exercised when administering ZAXINE to patients with severe (Child-Pugh C) hepatic impairment.

Immune

Hypersensitivity Reactions

Acute hypersensitivity reactions, including dyspnea, rash, pruritus, angioedema and anaphylaxis, have been reported with rifaximin (see **ADVERSE REACTIONS**). If a severe hypersensitivity reaction occurs, ZAXINE should be discontinued and appropriate therapy should be instituted.

Renal

The pharmacokinetics of rifaximin in patients with impaired renal function have not been studied.

Special Populations

Pregnant Women:

There are no adequate and well controlled studies in pregnant women. ZAXINE tablets should not be used during pregnancy unless the potential benefit to the mother outweighs the potential risk to the fetus.

Fetal rat malformations were observed in a study of pregnant rats administered a high dose of rifaximin that is equivalent to the therapeutic dose in patients with hepatic encephalopathy (based upon plasma AUC comparisons). Fetal rabbit malformations were observed from pregnant rabbits administered mid and high rifaximin doses that resulted in less than 0.1 times the dose in patients with hepatic encephalopathy, based upon plasma AUC comparisons. (See **TOXICOLOGY**).

Nursing Women:

It is not known whether ZAXINE is excreted in human milk. Because many drugs are excreted in human milk and because of the potential for adverse reactions from ZAXINE in nursing infants, a decision should be made whether to discontinue nursing or to discontinue the drug, taking into account the importance of the drug to the mother.

Pediatrics (< 18 years of age):

The safety and effectiveness of ZAXINE have not been established in patients < 18 years of age.

Geriatrics (> 65 years of age):

In the controlled trial with ZAXINE for hepatic encephalopathy, 19.4% were 65 and over, while 2.3% were 75 and over. In the controlled trial with ZAXINE for irritable bowel syndrome 11% were 65 and over, while 2% were 75 and over. No overall differences in safety or effectiveness were observed between these subjects and younger subjects, and other reported clinical experience has not identified differences in responses between the elderly and younger patients, but greater sensitivity of some older individuals cannot be ruled out.

ADVERSE REACTIONS

Adverse Drug Reaction Overview

The most common adverse reactions in the clinical and post-marketing setting are GI-related (e.g. diarrhea, nausea), the most serious of which is *C. difficile*-associated diarrhea. Rash, pruritus, pyrexia, anemia, dyspnea, arthralgia, muscle spasms and peripheral edema were also commonly reported with rifaximin use (1-15 %) and were seen at a higher frequency than in the placebo group.

Clinical Trial Adverse Drug Reactions

Because clinical trials are conducted under very specific conditions the adverse reaction rates observed in the clinical trials may not reflect the rates observed in practice and should not be compared to the rates in the clinical trials of another drug. Adverse drug reaction information from clinical trials is useful for identifying drug-related adverse events and for approximating rates.

Hepatic Encephalopathy

The safety of rifaximin in patients in remission from hepatic encephalopathy (HE) was evaluated in two studies, a randomized, double-blind, placebo-controlled Phase 3 study, RFHE3001, and a long-term, open-label study, RFHE3002.

Study RFHE3001 compared 140 patients treated with rifaximin (dose 550 mg twice daily for 6 months) to 159 patients treated with placebo, while study RFHE3002 treated 322 patients, of whom 152 were from the RFHE3001 study, with rifaximin 550 mg twice daily for 12 months (66% of patients) and for 24 months (39% of patients), for a median exposure of 512.5 days.

All adverse reactions that occurred in patients treated with rifaximin at an incidence $\geq 5\%$ and at a higher incidence ($\geq 1\%$) than placebo patients in RFHE3001 are reported in [Table 1](#).

Table 1: Adverse Events Occurring in $\geq 5\%$ of Patients Receiving Rifaximin and at a Higher Incidence than Placebo in Study RFHE3001

MedDRA System Organ Class	Event	Placebo N = 159 n (%)	Rifaximin (550 mg BID) N = 140 n (%)
Blood and lymphatic system disorders	Anaemia	6 (3.8)	11 (7.9)
Gastrointestinal disorders	Ascites	15 (9.4)	16 (11.4)
	Nausea	21 (13.2)	20 (14.3)
	Abdominal pain upper	8 (5.0)	9 (6.4)
General disorders and administration site conditions	Oedema peripheral	13 (8.2)	21 (15.0)
	Pyrexia	5 (3.1)	9 (6.4)
Musculoskeletal and connective tissue disorders	Muscle spasms	11 (6.9)	13 (9.3)
	Arthralgia	4 (2.5)	9 (6.4)
Nervous system disorders	Dizziness	13 (8.2)	18 (12.9)
Psychiatric disorders	Depression	8 (5.0)	10 (7.1)
Respiratory, thoracic and mediastinal	Dyspnoea	7 (4.4)	9 (6.4)

MedDRA System Organ Class	Event	Placebo N = 159 n (%)	Rifaximin (550 mg BID) N = 140 n (%)
disorders			
Skin and subcutaneous tissue disorders	Pruritus	10 (6.3)	13 (9.3)
	Rash	6 (3.8)	7 (5.0)

Table 2 includes rifaximin adverse drug reactions (considered drug-related by the investigator) observed in the placebo-controlled study RFHE3001 and the long term study RFHE3002 at an incidence $\geq 1\%$.

Table 2: Drug-Related TEAEs in $\geq 1\%$ of Rifaximin- or Placebo-Treated Subjects – (Study RFHE3001 and All Rifaximin Subjects from RFHE3001 and RFHE3002)

MedDRA System Organ Class Preferred Term	Event	RFHE3001		RFHE3001 and RFHE3002
		Placebo (N = 159) n (%)	Rifaximin 550 mg BID (N = 140) n (%)	All Rifaximin 550 mg BID (N = 392) n (%)
Gastrointestinal disorders	Diarrhea	11 (6.9)	5 (3.6)	9 (2.3)
	Nausea	12 (7.5)	4 (2.9)	10 (2.6)
	Abdominal distension	2 (1.3)	3 (2.1)	4 (1.0)
	Abdominal pain upper	3 (1.9)	2 (1.4)	4 (1.0)
	Abdominal pain	3 (1.9)	1 (0.7)	6 (1.5)
	Flatulence	3 (1.9)	1 (0.7)	5 (1.3)
	Vomiting	5 (3.1)	1 (0.7)	5 (1.3)
	Constipation	2 (1.3)	0	2 (0.5)
General disorders and administration site conditions	Fatigue	4 (2.5)	1 (0.7)	3 (0.8)
Infections and infestations	Clostridium colitis	0	2 (1.4)	2 (0.5)
Metabolism and nutrition disorders	Decreased appetite	2 (1.3)	0	0
Musculoskeletal and connective tissue disorders	Muscle spasms	2 (1.3)	5 (3.6)	6 (1.5)
Nervous system disorders	Dizziness	2 (1.3)	3 (2.1)	8 (2.0)
	Balance disorder	0	2 (1.4)	2 (0.5)
	Headache	5 (3.1)	2 (1.4)	2 (0.5)
	Hepatic encephalopathy	3 (1.9)	2 (1.4)	2 (0.5)
Psychiatric disorders	Insomnia	2 (1.3)	0	1 (0.3)
Skin and subcutaneous tissue disorders	Pruritus	3 (1.9)	2 (1.4)	2 (0.5)

MedDRA System Organ Class Preferred Term	Event	RFHE3001		RFHE3001 and RFHE3002
		Placebo (N = 159)	Rifaximin 550 mg BID (N = 140)	All Rifaximin 550 mg BID (N = 392)
		n (%)	n (%)	n (%)
	Rash	2 (1.3)	1 (0.7)	2 (0.5)

TEAE = treatment-emergent adverse event

Less Common Clinical Trial Adverse Drug Reactions (<1%)

The following adverse reactions, presented by body system, have also been reported (from the placebo-controlled clinical trial RFHE3001 and the long term study RFHE3002) in <1% of patients taking ZAXINE 550 mg taken orally two times a day for hepatic encephalopathy. The following includes adverse events, considered by the investigator to be drug-related:

Blood and lymphatic system disorders: Anaemia, coagulopathy

Ear and labyrinth disorders: Hypoacusis, tinnitus

Eye disorders: Conjunctivitis, visual acuity reduced

Gastrointestinal disorders: Abdominal pain, ascites, constipation, dyspepsia, dry mouth, faeces discoloured, stomach discomfort

General disorders and Administration Site Conditions: Asthenia, fatigue, oedema peripheral, pyrexia

Infections and Infestations: Infectious mononucleosis, Klebsiella bacteraemia, peritonitis bacterial

Injury, Poisoning and Procedural Complications: Fall

Metabolism and nutrition disorders: Anorexia, hypokalemia

Musculoskeletal, Connective Tissue, and Bone disorders: Back pain

Nervous System disorders: Amnesia, balance disorder, headache, hypogeusia, hyposmia

Psychiatric disorders: Anxiety, confusional state, disorientation, insomnia, mental status changes

Renal and urinary disorders: Dysuria

Skin and Subcutaneous Tissue disorders: Pruritus, rash, rash erythematous, swelling face, urticaria

Vascular disorders: Hot flush

Irritable Bowel Syndrome with Diarrhea

The safety of ZAXINE for the treatment of IBS-D was evaluated in 3 placebo-controlled studies in which 952 patients were randomized to ZAXINE 550 mg three times a day for 14 days.

Across the 3 studies, 96% of patients received at least 14 days of treatment with ZAXINE. In Trials 1 and 2, 624 patients received only one 14-day treatment. Trial 3 evaluated the safety of ZAXINE in 328 patients who received 1 open-label treatment and 2 double-blind repeat treatments of 14 days each over a period of up to 46 weeks. The combined population studied had a mean age of 47 (range: 18 to 88) years of whom approximately 11% of the patients were > 65 years old, 72% were female, 88% were White, 9% were Black and 12% were Hispanic.

The adverse reaction that occurred at a frequency $\geq 2\%$ in ZAXINE-treated patients at a higher rate than placebo in Trials 1 and 2 for IBS-D was:

- nausea (ZAXINE 3%, placebo 2%)

The adverse reactions that occurred at a frequency $> 2\%$ in ZAXINE-treated patients (n=328) at a higher rate than placebo (n=308) in Trial 3 for IBS-D during the double-blind treatment phase were:

- ALT increased (ZAXINE 2%, placebo 1%)
- nausea (ZAXINE 2%, placebo 1%)

Table 3 includes the TEAEs occurring in at least 1% of Rifaximin-treated subjects in the Phase 3 studies TARGET 3 and TARGET 1/TARGET 2; Safety Populations.

Table 3: Phase 3 Studies - TEAEs Occurring in at Least 1% of Rifaximin-Treated Subjects (TARGET 3 and TARGET 1/TARGET 2; Safety Populations)

Preferred Term	TARGET 3 Open-Label [1]				TARGET 3 Double-Blind [1]		TARGET 1/TARGET 2	
	OL (Only) Rifaximin 500 mg TID (N=1943) n (%)	DB Rifaximin 500 mg TID (N=328) n (%) [2]	DB Placebo (N=308) n (%) [2]	Total OL Rifaximin 500 mg TID (N=2579) n (%)	Rifaximin 500 mg TID (N=328) n (%)	Placebo (N=308) n (%)	Rifaximin 500 mg TID (N=624) n (%)	Placebo (N=634) n (%)
Treatment Period (During Treatment with Study Drug)								
Headache	21 (1.1)	3 (0.9)	5 (1.6)	29 (1.1)	2 (0.6)	5 (1.6)	25 (4.0)	28 (4.4)
Abdominal pain	12 (0.6)	2 (0.6)	3 (1.0)	17 (0.7)	1 (0.3)	2 (0.6)	17 (2.7)	17 (2.7)
Nausea	27 (1.4)	5 (1.5)	6 (1.9)	38 (1.5)	6 (1.8)	4 (1.3)	16 (2.6)	12 (1.9)
Diarrhoea	7 (0.4)	0	0	7 (0.3)	4 (1.2)	2 (0.6)	9 (1.4)	8 (1.3)
Flatulence	8 (0.4)	2 (0.6)	2 (0.6)	12 (0.5)	1 (0.3)	0	9 (1.4)	10 (1.6)
Abdominal distension	3 (0.2)	1 (0.3)	1 (0.3)	5 (0.2)	1 (0.3)	0	7 (1.1)	3 (0.5)
Nasopharyngitis	9 (0.5)	0	3 (1.0)	12 (0.5)	4 (1.2)	4 (1.3)	4 (0.6)	18 (2.8)
Alanine aminotransferase increased	14 (0.7)	2 (0.6)	1 (0.3)	17 (0.7)	7 (2.1)	3 (1.0)	0	4 (0.6)
Aspartate aminotransferase increased	15 (0.8)	2 (0.6)	0	17 (0.7)	5 (1.5)	2 (0.6)	0	2 (0.3)

Preferred Term	TARGET 3 Open-Label [1]				TARGET 3 Double-Blind [1]		TARGET 1/ TARGET 2	
	OL (Only) Rifaximin 500 mg TID (N=1943) n (%)	DB Rifaximin 500 mg TID (N=328) n (%) [2]	DB Placebo (N=308) n (%) [2]	Total OL Rifaximin 550 mg TID (N=2579) n (%)	Rifaximin 500 mg TID (N=328) n (%)	Placebo (N=308) n (%)	Rifaximin 500 mg TID (N=624) n (%)	Placebo (N=634) n (%)
Blood creatine phosphokinase increased	17 (0.9)	3 (0.9)	2 (0.6)	22 (0.9)	4 (1.2)	2 (0.6)	0	0
Clostridium test positive	25 (1.3)	0	0	25 (1.0)	0	0	0	0
Overall Evaluation Period (During Treatment with Study Drug + Off-Treatment Intervals [Follow-Up + Maintenance])								
Headache	28 (1.4)	7 (2.1)	7 (2.3)	42 (1.6)	4 (1.2)	9 (2.9)	38 (6.1)	42 (6.6)
Upper respiratory tract infection	29 (1.5)	8 (2.4)	4 (1.3)	41 (1.6)	12 (3.7)	8 (2.6)	35 (5.6)	39 (6.2)
Abdominal pain	26 (1.3)	2 (0.6)	4 (1.3)	32 (1.2)	3 (0.9)	2 (0.6)	29 (4.6)	35 (5.5)
Diarrhoea	20 (1.0)	0	0	20 (0.8)	7 (2.1)	3 (1.0)	27 (4.3)	22 (3.5)
Nausea	35 (1.8)	8 (2.4)	9 (2.9)	52 (2.0)	12 (3.7)	7 (2.3)	27 (4.3)	24 (3.8)
Nasopharyngitis	29 (1.5)	3 (0.9)	4 (1.3)	36 (1.4)	10 (3.0)	9 (2.9)	19 (3.0)	34 (5.4)
Sinusitis	21 (1.1)	5 (1.5)	8 (2.6)	34 (1.3)	7 (2.1)	7 (2.3)	17 (2.7)	16 (2.5)
Vomiting	13 (0.7)	4 (1.2)	7 (2.3)	24 (0.9)	2 (0.6)	5 (1.6)	15 (2.4)	9 (1.4)
Bronchitis	12 (0.6)	1 (0.3)	2 (0.6)	15 (0.6)	9 (2.7)	5 (1.6)	13 (2.1)	17 (2.7)
Cough	7 (0.4)	4 (1.2)	2 (0.6)	13 (0.5)	3 (0.9)	5 (1.6)	13 (2.1)	9 (1.4)
Urinary tract infection	25 (1.3)	4 (1.2)	6 (1.9)	35 (1.4)	11 (3.4)	15 (4.9)	12 (1.9)	11 (1.7)
Abdominal distension	5 (0.3)	1 (0.3)	1 (0.3)	7 (0.3)	2 (0.6)	0	11 (1.8)	10 (1.6)
Back pain	11 (0.6)	1 (0.3)	2 (0.6)	14 (0.5)	5 (1.5)	5 (1.6)	10 (1.6)	15 (2.4)
Flatulence	8 (0.4)	2 (0.6)	2 (0.6)	12 (0.5)	1 (0.3)	0	10 (1.6)	14 (2.2)
Dyspepsia	6 (0.3)	3 (0.9)	2 (0.6)	11 (0.4)	1 (0.3)	1 (0.3)	9 (1.4)	8 (1.3)
Influenza	17 (0.9)	12 (3.7)	4 (1.3)	33 (1.3)	7 (2.1)	2 (0.6)	9 (1.4)	9 (1.4)
Pharyngolaryngeal pain	0	0	0	0	0	0	9 (1.4)	15 (2.4)
Vulvovaginal mycotic infection	7 (0.4)	2 (0.6)	4 (1.3)	13 (0.5)	1 (0.3)	0	8 (1.3)	7 (1.1)

Preferred Term	TARGET 3 Open-Label [1]				TARGET 3 Double-Blind [1]		TARGET 1/TARGET 2	
	OL (Only) Rifaximin 500 mg TID (N=1943) n (%)	DB Rifaximin 500 mg TID (N=328) n (%) [2]	DB Placebo (N=308) n (%) [2]	Total OL Rifaximin 550 mg TID (N=2579) n (%)	Rifaximin 500 mg TID (N=328) n (%)	Placebo (N=308) n (%)	Rifaximin 500 mg TID (N=624) n (%)	Placebo (N=634) n (%)
Abdominal tenderness	6 (0.3)	1 (0.3)	0	7 (0.3)	1 (0.3)	0	7 (1.1)	7 (1.1)
Dizziness	12 (0.6)	3 (0.9)	2 (0.6)	17 (0.7)	3 (0.9)	2 (0.6)	7 (1.1)	8 (1.3)
Gastroenteritis viral	11 (0.6)	2 (0.6)	1 (0.3)	14 (0.5)	4 (1.2)	3 (1.0)	7 (1.1)	8 (1.3)
Migraine	2 (0.1)	0	3 (1.0)	5 (0.2)	0	1 (0.3)	7 (1.1)	3 (0.5)
Nasal congestion	2 (0.1)	0	3 (1.0)	5 (0.2)	0	3 (1.0)	7 (1.1)	3 (0.5)
Tooth abscess	0	0	0	0	1 (0.3)	1 (0.3)	7 (1.1)	3 (0.5)
Alanine aminotransferase increased	20 (1.0)	3 (0.9)	1 (0.3)	24 (0.9)	9 (2.7)	4 (1.3)	6 (1.0)	7 (1.1)
Aspartate aminotransferase increased	22 (1.1)	2 (0.6)	0	24 (0.9)	7 (2.1)	4 (1.3)	5 (0.8)	5 (0.8)
Arthralgia	10 (0.5)	5 (1.5)	2 (0.6)	17 (0.7)	3 (0.9)	8 (2.6)	4 (0.6)	4 (0.6)
Gamma-glutamyltransferase increased	14 (0.7)	2 (0.6)	0	16 (0.6)	5 (1.5)	1 (0.3)	4 (0.6)	3 (0.5)
Hypertension	9 (0.5)	2 (0.6)	1 (0.3)	12 (0.5)	5 (1.5)	4 (1.3)	4 (0.6)	3 (0.5)
Muscle strain	6 (0.3)	4 (1.2)	1 (0.3)	11 (0.4)	1 (0.3)	1 (0.3)	3 (0.5)	1 (0.2)

^a All 2579 subjects in the open-label Treatment Phase 2 of TARGET 3 received rifaximin: 1943 of these subjects participated only in the Treatment Phase 2, while 636 subjects went on to be randomized in DBR Treatment Phase 3 and subsequently to participate in the repeat-treatment phases, that is, DBR Treatment Phase 3 and SRT Treatment Phase 4. Open label includes Treatment Phase 2 and Maintenance Phase 1. Double-blind includes Treatment Phases 3 (DBR) and 4 (SRT) including follow-up periods, Maintenance Phase 2, and the final 4-week follow up. Treatment Period includes only the 14-day treatment period, whereas Overall Evaluation Period includes all treatment, follow up, and maintenance periods.

^b These columns provide TEAEs during the OL experienced by subjects eventually randomized to the DB period.

Abnormal Hematologic and Clinical Chemistry Findings

In TARGET 1, TARGET 2, and TARGET 3, abnormal clinical laboratory test results that were considered by the investigator to be clinically significant were to be recorded as adverse events. ALT, AST, and CPK increases were reported as adverse events with similar frequency during the treatment period for ZAXINE and placebo in TARGET 1 and TARGET 2. For the double-blind

treatment period of TARGET 3, frequencies of ALT, AST, and CPK increase adverse events for ZAXINE and placebo were 2.1% versus 1.0%, 1.5% versus 0.6%, and 1.2% versus 0.6%, respectively. Thrombocytopenia was not reported in TARGET 1, TARGET 2, or in the double-blind phase of TARGET 3. Thrombocytopenia was reported in 2 subjects in the open-label phase of TARGET 3; both resolved on continued treatment with ZAXINE. Anemia was reported in 2 placebo subjects in TARGET 2, and in no subject in TARGET 1 or in the double-blind phase of TARGET 3. In the open-label phase of TARGET 3, anemia was reported in 3 subjects and macrocytic anemia was reported in 1 subject treated with ZAXINE; none of the adverse events were considered related to treatment.

Post-Market Adverse Drug Reactions

The following adverse reactions have been identified during post approval use of ZAXINE. Because these reactions are reported voluntarily from a population of unknown size, estimates of frequency cannot be made. These reactions have been chosen for inclusion due to either their seriousness, frequency of reporting or causal connection to ZAXINE.

Infections and Infestation: *C. difficile*-associated colitis

General: Hypersensitivity reactions, including exfoliative dermatitis, rash, angioneurotic edema (swelling of face and tongue and difficulty swallowing), urticaria, flushing, pruritus and anaphylaxis have been reported. These events occurred as early as within 15 minutes of drug administration.

DRUG INTERACTIONS

Overview

Rifaximin is a structural analog of rifampin, a rifamycin derivative. ZAXINE contains rifaximin- α , one of the polymorphic forms of rifaximin. Low systemic absorption of this alfa form has been noted in healthy individuals, but absorption is increased in subjects with impaired hepatic function, and to a lesser extent, in patients with inflammatory bowel disease and irritable bowel syndrome.

In Vitro Data

In vitro studies in human hepatocytes have demonstrated:

- Rifaximin is metabolized by CYP3A4.
- Rifaximin is a weak inducer of CYP3A4 (at a concentration of 0.2 μ M [157 ng/ml]).
- Rifaximin did not inhibit cytochrome P450 isoenzymes 1A2, 2A6, 2B6, 2C9, 2C19, 2D6, 2E1 and CYP3A4 at concentrations ranging up from 2 to 200 ng/mL.

An *in vitro* study suggested that rifaximin is a substrate of, and a weak inhibitor of P-glycoprotein (P-gp) (See **DETAILED PHARMACOLOGY**).

Drug-Drug Interactions

Error! Reference source not found. summarizes the potential for drug-drug interactions with rifaximin.

Table 4: Established or Potential Drug-Drug Interactions for Rifaximin

Proper name	Reference	Effect	Clinical comment
CYP3A4 substrates (e.g. Midazolam)	CT	Rifaximin 550 mg bid x 7 or 14 days reduced oral midazolam AUC by 4 – 9%, and C _{max} by 4-5% in healthy subjects	Rifaximin is a substrate and a weak inducer of CYP3A4 <i>in vitro</i> . No clinically significant effects on the pharmacokinetics of CYP3A4 substrates were found in healthy subjects; however, the effect of rifaximin on CYP3A4 substrates in subjects with hepatic impairment has not been evaluated. The drug could have an effect on the pharmacokinetics of concomitant CYP3A4 substrates (eg. warfarin, antiepileptics, antiarrhythmics) in hepatically impaired subjects who have elevated systemic levels of rifaximin.
P-gp inhibitors (e.g. Cyclosporine)	CT	Cyclosporine 600 mg increased C _{max} of rifaximin 83-fold and increased AUC 124-fold in healthy subjects	Concomitant drugs that inhibit P-gp could significantly increase the systemic exposure of rifaximin in hepatically impaired subjects, in particular in patients with severe hepatic impairment
P-gp substrates (e.g. Digoxin)	T	Rifaximin showed weak inhibition of digoxin transport <i>in vitro</i> at concentrations 100 times clinical C _{max} in healthy subjects	Clinical relevance in hepatically impaired subjects is unknown
Oral Contraceptives - CYP3A4 substrate and potential for rifaximin-induced altered gut flora effect (e.g. ethinyl estradiol and norgestimate)	CT	After rifaximin 550 mg TID x 7 days in healthy volunteers, C _{max} of OC minimally lowered, but no change in AUC of OC.	OC C _{max} within clinically reported values. Clinical relevance of minimal C _{max} reduction in healthy volunteers and effects on contraception are unknown.
Warfarin	Case Study	A patient on rifaximin 400 mg TID x 10 days for small intestinal bacterial overgrowth, also on a stable warfarin dose, had elevated INR while on rifaximin.	Patient was on stable warfarin therapy, and when given rifaximin treatment for small intestinal bacterial overgrowth, anticoagulation was attenuated. This potential interaction has not been studied in a controlled clinical trial.

CT = Clinical Trial; T = Theoretical

Drug-Food Interactions

In healthy volunteers, administration of rifaximin within 30 minutes of a standardized high-fat breakfast increased C_{max} and AUC by approximately 1.2- and 2-fold, respectively.

Drug-Herb Interactions

Interactions with herbal products have not been established.

Drug-Laboratory Interactions

Interactions with laboratory tests have not been established.

DOSAGE AND ADMINISTRATION

Dosing Considerations

Due to the limited systemic absorption of ZAXINE (rifaximin), no specific dosing adjustment is recommended for patients with mild to moderate hepatic insufficiency.

Although no dosage adjustment is recommended at this time, caution should be exercised when ZAXINE is administered to patients with severe (Child-Pugh C) hepatic impairment and in patients with MELD score ≥ 25 (see **ACTION AND CLINICAL PHARMACOLOGY, Pharmacokinetics**). While taking ZAXINE with food has resulted in small increases in systemic exposure in healthy subjects, the effects of food on ZAXINE exposure in hepatic impairment patients have not been studied. However, since the absolute systemic bioavailability of rifaximin is still relatively low and the drug works locally in the gastrointestinal tract, rifaximin can be given with or without food.

Treatment duration beyond 6 months should take into consideration the individual balance between benefits and risks, including those associated with the progression of hepatic dysfunction and increasing systemic exposure to rifaximin.

Recommended Dose and Dosage Adjustment

Hepatic Encephalopathy

The recommended dose of ZAXINE is one 550 mg tablet taken orally two times a day. No more than two doses of ZAXINE (1 tablet twice a day) should be taken in a 24-hour period.

Irritable Bowel Syndrome with Diarrhea

The recommended dose of ZAXINE is one 550 mg tablet taken orally three times a day for 14 days.

In the trials of ZAXINE for IBS-D, patients who experienced a recurrence of symptoms and who responded to a first treatment were safely and effectively retreated for up to 2 times. Current clinical trials have not evaluated the safety and efficacy of three or more repeat treatments for IBS-D.

No more than three doses of ZAXINE (1 tablet three times a day) should be taken in a 24-hour period.

ZAXINE can be taken with or without food (see **ACTION AND CLINICAL PHARMACOLOGY, Pharmacokinetics, Table 7**). Tablets should be swallowed whole.

Missed Dose

If a dose is missed, it should be taken as soon as possible. However, if it is almost time for the next dose, no additional dose should be taken and the regular dosing schedule should be resumed.

OVERDOSAGE

No specific information is available on the treatment of overdose with ZAXINE (rifaximin). In clinical studies at doses higher than the recommended dose (i.e., > 1100 mg/day for HE and 1650 mg/day for IBS-D [up to a daily maximum of 2400 mg rifaximin]), adverse reactions were similar in subjects receiving ZAXINE or placebo. In the case of overdose, discontinue ZAXINE, treat symptomatically, and institute supportive measures as required.

For management of a suspected drug overdose, contact your regional Poison Control Centre.

ACTION AND CLINICAL PHARMACOLOGY

Mechanism of Action

Rifaximin is a non-aminoglycoside semi-synthetic antibacterial derived from rifamycin SV. Rifaximin acts by binding to the beta-subunit of bacterial DNA-dependent RNA polymerase resulting in inhibition of bacterial RNA synthesis. Rifaximin has a broad antimicrobial spectrum against many Gram-positive, Gram-negative, aerobic and anaerobic bacteria, including ammonia-producing species. Rifaximin may also be effective against enteric protozoal infections, including *Cryptosporidium* and *Blastocystis*. Rifaximin may also modulate the local gut inflammatory host response through the select activation of the human pregnane X receptor (PXR).

Due to the generally low absorption from the gastro-intestinal tract, rifaximin is locally-acting in the intestinal lumen and clinically not effective against invasive pathogens.

In Hepatic Encephalopathy:

Rifaximin is believed to reduce recurrence of overt hepatic encephalopathy (HE) by decreasing the bacterial toxin load on the liver of cirrhotic. As a result, decreasing the neuroinflammation response to toxins and other bacterial products experienced in the central nervous system that can precipitate HE episodes.

Irritable Bowel Syndrome with Diarrhea:

Microbiota in the GI track are believed to play an important role in the development of these symptoms especially those associated with IBS-D. It has been shown that an acute gastrointestinal infection can increase the odds by six-fold of developing IBS. It is suggested

that a dysbiosis in the microbiome can lead to increased bloating by way of increased fermentation/gas, small intestinal bacterial overgrowth, mucosal irritation and minimal chronic localized inflammation in the gut.

A sustained effect in IBS-D has been observed following a 2-week treatment course with rifaximin. This suggests that rifaximin may affect the underlying causes of IBS-D mediated by bacterial dysbiosis. Rifaximin's primary mode of action reduces the bacterial load and bacterial products that can negatively affect the host, alleviating the most common symptoms of IBS-D including bloating, abdominal pain and diarrhea. Furthermore, rifaximin's effect on gut microbiota may reduce the local immune responses and by suppressing the effect of bacterial endotoxins helping to prevent dysbiosis, maintain homeostasis and mucosal integrity. Rifaximin may also modulate the patient's local immune responses directly via the PXR pathway; it has been shown to reduce and reverse local mucosal inflammation.

Pharmacokinetics

Absorption:

Hepatic Encephalopathy

After a single dose and multiple doses of ZAXINE (rifaximin) 550 mg in healthy subjects, the mean time to reach peak plasma concentrations was about an hour. The pharmacokinetic (PK) parameters were highly variable and the accumulation ratio based on AUC was 1.37. The dosing interval was BID or every 12 hours (Table 5).

The PK of ZAXINE in patients with a history of HE was evaluated after administration of ZAXINE, 550 mg two times a day. The PK parameters were associated with a high variability and mean ZAXINE exposure (AUC_{τ}) in patients with a history of HE (147 ng•h/mL) was approximately 12-fold higher than that observed in healthy subjects following the same dosing regimen (12.3 ng•h/mL). When PK parameters were analyzed based on Child-Pugh Class A, B, and C, the mean AUC_{τ} was 10-, 13-, and 20-fold higher, respectively, compared to that in healthy subjects (Table 5).

Table 6: Mean (\pm SD) Pharmacokinetic Parameters of ZAXINE at Steady-State in Patients with a History of Hepatic Encephalopathy by Child-Pugh Class¹

Pharmacokinetic Parameter	Healthy Subjects (n=14)	Child-Pugh Class		
		A (n=18)	B (n=15)	C (n=6)
AUC_{τ} (ng•h/mL)	12.3 \pm 4.8	118 \pm 67.8	169 \pm 55.7	257 \pm 100
C_{\max} (ng/mL)	3.4 \pm 1.6	19.5 \pm 11.4	25.4 \pm 11.9	39.7 \pm 13.5
T_{\max}^b (h), range	0.8 (0.5, 4.0)	1 (0.9, 10)	1 (0.97, 4.2)	1 (0, 2)
$T_{1/2}$ (h)	4.2 \pm 3.3	8.1 \pm 3.6	8.0 \pm 2.5	6.4 \pm 1.1

¹ Cross-study comparison with PK parameters in healthy subjects

² Median

Irritable Bowel Syndrome with Diarrhea

In patients with irritable bowel syndrome with diarrhea (IBS-D) treated with ZAXINE 550 mg three times a day for 14 days, the median T_{max} was 1 hour and mean C_{max} and AUC were generally comparable with those in healthy subjects. After multiple doses, AUC was 1.65-fold higher than that on Day 1 in IBS-D patients (Table 7).

Table 8: Mean (\pm SD) Pharmacokinetic Parameters of Rifaximin Following ZAXINE 550 mg Three Times a Day in IBS-D Patients and Healthy Subjects

Pharmacokinetic Parameter	Healthy Subjects		IBS-D Patients	
	Single-Dose (Day 1) n=12	Multiple-Dose (Day 14) n=14	Single-Dose (Day 1) n=24	Multiple-Dose (Day 14) n=24
AUC _{tau} (ng•h/mL)	10.4 (3.47)	9.30 (2.7)	9.69 (4.16)	16.0 (9.59)
C_{max} (ng/mL)	4.04 (1.51)	2.39 (1.28)	3.49 (1.36)	4.22 (2.66)
T_{max} (h)*, range	0.75 (0.5-2.1)	1.00 (0.5-2.0)	0.78 (0-2)	1.00 (0.5-2)
$T_{1/2}$ (h)	1.83 (1.38)	5.63 (5.27)	3.14 (1.71)	6.08(1.68)

*Median

Food Effect in Healthy Subjects

A high-fat meal consumed 30 minutes prior to ZAXINE dosing in healthy subjects delayed the mean time to peak plasma concentration from 0.8 to 1.5 hours and increased the systemic exposure (AUC) of ZAXINE by 2-fold (Table 9 **Error! Reference source not found.**).

However, since the absolute systemic bioavailability of rifaximin is still relatively low and the drug works locally in the gastrointestinal tract, rifaximin can be given with or without food.

Table 10: Mean (\pm SD) Pharmacokinetic Parameters after Single-Dose Administration of Rifaximin 550 mg in Healthy Subjects under Fasting and Fed Conditions (N=12)

Rifaximin Parameters	Fasting	Fed
C_{max} (ng/mL)	4.0 \pm 1.5	4.8 \pm 4.3
T_{max} (h) ^a	0.8 (0.5, 2.1)	1.5 (0.5, 4.1)
$t_{1/2}$ (h)	1.8 \pm 1.4	4.8 \pm 1.3
AUC _{0-∞} (ng•h/mL)	11.1 \pm 4.2	22.5 \pm 12

^aMedian and range

Distribution:

Rifaximin is moderately bound to human plasma proteins. *In vivo*, the mean protein binding ratio was 67.5% in healthy subjects and 62% in patients with hepatic impairment when ZAXINE 550 mg was administered.

Metabolism and Excretion:

In vitro studies in human liver cell lines suggested that rifaximin is metabolized by CYP3A4. (See **DETAILED PHARMACOLOGY, HUMAN PHARMACOLOGY.**)

Rifaximin is almost exclusively excreted in faeces. In a mass balance study, after administration of 400 mg ¹⁴C-rifaximin orally to healthy subjects, of the 96.94% total recovery, 96.62% of the

administered radioactivity was recovered in faeces almost exclusively as the unchanged drug and 0.32% was recovered in urine mostly as metabolites with 0.03% as the unchanged drug. This suggests that the absorbed rifaximin undergoes metabolism with minimal renal excretion of the unchanged drug. Rifaximin was detected in the bile after cholecystectomy in patients with intact gastrointestinal mucosa, indicating some biliary excretion of systemically absorbed rifaximin.

Special Populations and Conditions

Hepatic Insufficiency: The systemic exposure of rifaximin was elevated in patients with hepatic impairment compared to healthy subjects. When PK parameters were analyzed based on Child-Pugh Class A, B, and C, the mean AUC_τ was 10-, 13-, and 20-fold higher, respectively, compared to that in healthy subjects. (See **ACTION AND CLINICAL PHARMACOLOGY, Pharmacokinetics, Table 5.**)

Renal Insufficiency: The pharmacokinetics of rifaximin in patients with impaired renal function have not been studied.

STORAGE AND STABILITY

Store ZAXINE (rifaximin) tablets at 20–25°C (68–77°F); excursions permitted to 15–30°C (59–86°F). Store in a tightly closed container away from heat and direct light.

DOSAGE FORMS, COMPOSITION AND PACKAGING

ZAXINE (rifaximin) 550 mg is a pink, oval, biconvex tablet with “rfx” debossed on one side. It is available in bottles of 60 tablets.

Non-medicinal ingredients: colloidal silicon dioxide, glyceryl distearate, microcrystalline cellulose, polyethylene glycol, polyvinyl alcohol, red iron oxide, gluten-free sodium starch glycolate, talc, and titanium dioxide.

PART II: SCIENTIFIC INFORMATION

PHARMACEUTICAL INFORMATION

Drug Substance

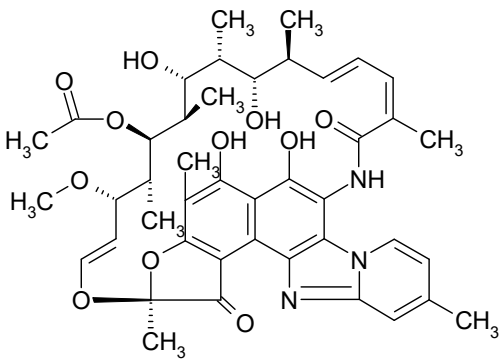
Proper name:	Rifaximin
Chemical name:	(2 <i>S</i> ,16 <i>Z</i> ,18 <i>E</i> ,20 <i>S</i> ,21 <i>S</i> ,22 <i>R</i> ,23 <i>R</i> ,24 <i>R</i> ,25 <i>S</i> ,26 <i>S</i> ,27 <i>S</i> ,28 <i>E</i>)-5,6,21,23,25-pentahydroxy-27-methoxy-2,4,11,16,20,22,24,26-octamethyl-2,7-(epoxypentadeca-[1,11,13]trienimino)benzofuro[4,5- <i>e</i>]pyrido[1,2- α]-benzimidazole-1,15(2 <i>H</i>)-dione,25-acetate
Molecular formula and molecular mass:	C ₄₃ H ₅₁ N ₃ O ₁₁ MW=785.9
Structural formula:	

Physicochemical properties: Rifaximin is red/orange microcrystalline powder, soluble in methanol, chloroform, acetone and ethyl acetate. It is practically insoluble in water. It has a pK_a of 6.77. The partition co-efficient (*n*-octanol-water) is 2.76.

CLINICAL TRIALS

Hepatic Encephalopathy

The safety and efficacy of ZAXINE (rifaximin) 550 mg twice daily in adult patients in remission from overt HE was assessed in one randomized double-blind, parallel group, controlled multicentre six-month trial, and in one multicentre, open-label, long term study. Study demographics and trial design are summarized in [Table 8](#).

Table 11: Summary of Patient Demographics for Clinical Trials in Prevention of Overt HE Recurrence in Patients ≥18 Years of Age

Study #	Trial design	Dosage, route of administration and duration	Study subjects (N = number)	Mean age (Range)	Gender
RFHE3001 (Pivotal - Safety and Efficacy)	Randomized placebo controlled, double-blind, multicentre (US, Canada, Russia)	550 mg BID, oral, up to 6 months Placebo BID, up to 6 months	N = 299 Rifaximin = 140 Placebo = 159	56 years (21-82 years)	61% male
RFHE3002 (Safety)	Open-label, multicentre (US, Canada, Russia), treatment extension study	550 mg BID, oral at least 24 months	N = 322 rifaximin subjects (152 from study 3001 [70 rifaximin and 82 placebo] and 170 new subjects)	57 years (21-82 years)	61 % male

More than 90% of the subjects in both studies received concomitant lactulose. No patients were enrolled with a MELD score >25.

Study Results RFHE3001:

The primary efficacy endpoint was the time to first breakthrough overt HE episode. Patients were withdrawn after a breakthrough overt HE episode.

Breakthrough overt HE episodes were experienced by 31 of 140 subjects (22%) in the ZAXINE group and by 73 of 159 subjects (46%) in the placebo group during the 6-month treatment period. ZAXINE significantly reduced the risk of overt HE breakthrough by 58% ($p < 0.0001$) during the 6-month treatment period.

A key secondary endpoint included time to first HE-related hospitalization. HE-related hospitalizations (hospitalizations directly resulting from HE, or hospitalizations complicated by HE) were reported for 19 of 140 subjects (14%) and 36 of 159 subjects (23%) in the ZAXINE and placebo groups, respectively. ZAXINE significantly reduced the risk of overt HE-related hospitalizations by 50% ($p < 0.0129$) during the 6-month treatment period (see [Table 9](#)).

Study Results RFHE3002:

In this open-label, uncontrolled study, treatment with ZAXINE for periods up to 24 months did not result in any loss of effect regarding protection from breakthrough overt HE episodes and the reduction in the burden of hospitalization. The time to first breakthrough overt HE episode profiles demonstrated long-term maintenance of remission in new ZAXINE subjects in RFHE3002 (including placebo crossover subjects from RFHE3001) and continuing ZAXINE subjects in RFHE3002 (i.e., ZAXINE rollover subjects from RFHE3001) (see Table 11).

Table 12: Rates of HE-Related and All-Cause Hospitalizations

Hospitalization Rates	Historical Placebo (RFHE3001) n=159	Historical Rifaximin (RFHE3001) n=140	New Rifaximin (RFHE3002) n=252	All Rifaximin (RFHE3001 + RFHE3002) n=392
HE related Hospitalization rates (events/PYE)	0.72	0.30*	0.23	0.21
All – Cause Hospitalization rates (events/PYE)	1.30	0.92	0.44	0.45

Rates of HE-related and all-cause hospitalizations for the all-rifaximin and new-rifaximin populations in the OLM compared with patients receiving historical placebo or rifaximin in the 6-month RCT (RFHE3001). *p < 0.0001 vs placebo. The integrated all-rifaximin population includes 70 from the treatment group in RFHE3001, 70 from treatment group in RFHE3001 that transitioned to RFHE3002, 82 from the placebo group that transitioned to receive rifaximin in RFHE3002 and 170 new patients enrolled in RFHE3002.

Irritable Bowel Syndrome with Diarrhea

The efficacy of ZAXINE (rifaximin) 550 mg for the treatment of IBS-D was established in 3 randomized, multicenter, double-blind, placebo-controlled trials in adult patients.

TARGET 1 and TARGET 2 Design

The first two trials, TARGET 1 and TARGET 2 were of identical design. In these trials, a total of 1258 patients meeting Rome II criteria for IBS* were randomized to receive ZAXINE 550 mg three times a day (n=624) or placebo (n=634) for 14 days and then followed for a 10-week treatment-free period. The Rome II criteria further categorizes IBS patients into 3 subtypes: diarrhea-predominant IBS (IBS-D), constipation-predominant IBS (IBS-C), or alternating IBS (bowel habits alternating between diarrhea and constipation). Patients with both IBS-D and alternating IBS were included in TARGET 1 and TARGET 2. ZAXINE is recommended for use in patients with IBS-D.

*Rome II Criteria: At least 12 weeks, which need not be consecutive, in the preceding 12 months of abdominal discomfort or pain that has two out of three features: 1. Relieved with defecation; and/or 2. Onset associated with a change in frequency of stool; and/or 3. Onset associated with a change in form (appearance) of stool.

Symptoms that Cumulatively Support the Diagnosis of Irritable Bowel Syndrome

Abnormal stool frequency (for research purposes “abnormal” may be defined as greater than 3 bowel movements per day and less than 3 bowel movements per week); Abnormal stool form (lumpy/hard or loose/watery stool); Abnormal stool passage (straining, urgency, or feeling of incomplete evacuation); Passage of mucus; Bloating or feeling of abdominal distension.

Study Results TARGET 1 and TARGET 2:

TARGET 1 and TARGET 2 included 1,258 IBS-D patients (309 ZAXINE, 314 placebo) and (315 ZAXINE, 320 placebo). The primary endpoint for both trials was the proportion of patients who achieved adequate relief of IBS signs and symptoms for at least 2 of 4 weeks during the month following 14 days of treatment. Adequate relief was defined as a response of “yes” to the following weekly Subject Global Assessment (SGA) question: “In regards to your IBS symptoms, compared to the way you felt before you started study medication, have you, in the past 7 days, had adequate relief of your IBS symptoms? [Yes/No].”

Adequate relief of IBS symptoms was experienced by more patients receiving ZAXINE than those receiving placebo during the month following 2 weeks of treatment (SGA-IBS Weekly Results: 41% vs. 31%, p=0.0125; 41% vs. 32%, p=0.0263 (See [Table 10](#)).

Table 13: Adequate Relief of IBS Symptoms during the Month Following Two Weeks of Treatment

Endpoint	TARGET 1			TARGET 2		
	ZAXINE n=309 n (%)	Placebo n=314 n (%)	Treatment Difference (95% CI ^a)	ZAXINE n=315 n (%)	Placebo n=320 n (%)	Treatment Difference (95% CI ^a)
Adequate Relief of IBS Symptoms ^b	126 (41)	98 (31)	10% (2.1%, 17.1%)	128 (41)	103 (32)	8% (1.0%, 15.9%)

^a Confidence Interval

^b The p-value for the primary endpoint for TARGET 1 and for TARGET 2 was < 0.05

The trials examined a composite endpoint which defined responders by IBS-related abdominal pain *and* stool consistency measures. Patients were monthly responders if they met both of the following criteria:

- experienced a $\geq 30\%$ decrease from baseline in abdominal pain for ≥ 2 weeks during the month following 2 weeks of treatment
- had a weekly mean stool consistency score < 4 (loose stool) for ≥ 2 weeks during the month following 2 weeks of treatment

More patients receiving ZAXINE were monthly responders for abdominal pain *and* stool consistency in TARGET 1 and 2 (see [Table 11](#)).

Table 14: Efficacy Responder Rates in TARGET 1 and 2 during the Month Following Two Weeks of Treatment

Endpoint	TARGET 1			TARGET 2		
	ZAXINE n=309 n (%)	Placebo n=314 n (%)	Treatment Difference (95% CI ^a)	ZAXINE n=315 n (%)	Placebo n=320 n (%)	Treatment Difference (95% CI ^a)
Abdominal Pain and Stool Consistency Responders ^b	144 (47)	121 (39)	8% (0.3%, 15.9%)	147 (47)	116 (36)	11% (2.7%, 18.0%)
Abdominal Pain Responders ^c	159 (51)	132 (42)	9% (1.8%, 17.5%)	165 (52)	138 (43)	9% (1.5%, 17.0%)
Stool Consistency Responders ^d	244 (79)	212 (68)	11% (4.4%, 18.2%)	233 (74)	206 (64)	10% (2.3%, 16.7%)

^a Confidence Interval

^b The p-value for the composite endpoint for TARGET 1 and for TARGET 2 was < 0.05 and < 0.01, respectively

^c The p-value for TARGET 1 and for TARGET 2 was < 0.02

^d The p-value for TARGET 1 and for TARGET 2 was < 0.01

The safety profile during and after treatment with rifaximin 550 mg TID for 14 days was comparable to that observed with placebo in both studies. A similar proportion of rifaximin-treated subjects and placebo-treated subjects (55% vs 55% in TARGET 1 and 54 vs 52% in TARGET 2, respectively) experienced TEAEs (Treatment-emergent adverse event) during this study.

TARGET 3 – Study Design

TARGET 3 evaluated repeat treatment in adults with IBS-D meeting Rome III criteria** for up to 46 weeks. A total of 2579 were enrolled to receive open-label ZAXINE for 14 days. Of the 2438 evaluable patients, 1074 (44%) responded to initial treatment and were evaluated over 22 weeks for continued response or recurrence of IBS-symptoms. A total of 636 patients had symptom recurrence and were randomized into the double-blind phase of the study. These patients were scheduled to receive ZAXINE 550 mg three times a day (n=328) or placebo (n=308) for two additional 14-day repeat treatment courses separated by 10 weeks, see [Error! Reference source not found.](#)

Figure 1: Target 3 Study Design

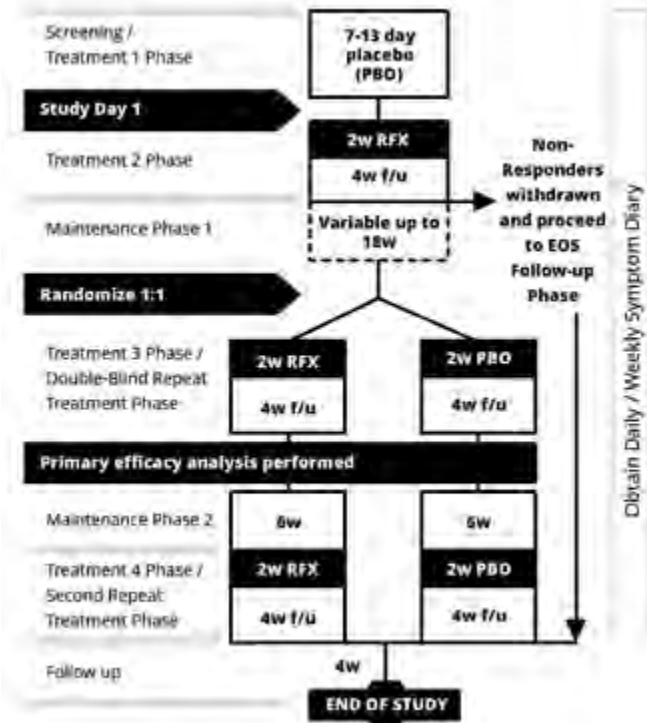

****Rome III Criteria:** Recurrent abdominal pain or discomfort (uncomfortable sensation not described as pain) at least 3 days/month in last 3 months associated with two or more of the following: 1) improvement with defecation; 2) onset associated with a change in frequency of stool; 3) onset associated with a change in form (appearance) of stool.

Demographics:

The IBS-D population from the three studies (TARGET 1, 2 and 3) had mean age of 47 (range: 18 to 88) years of which approximately 11% of patients were ≥ 65 years old, 72% were female and 88% were white.

Study Results TARGET 3:

In TARGET 3, 2,579 patients were scheduled to receive an initial 14-day course of open-label ZAXINE followed by 4 weeks of treatment-free follow-up. At the end of the follow-up period, patients were assessed for response to treatment. Patients were considered responders if they simultaneously met the weekly response criteria during ≥ 2 of the 4 weeks after treatment for the following:

- $\geq 30\%$ improvement from baseline in the weekly average abdominal pain score based on the daily question: *“In regards to your specific IBS symptoms of abdominal pain, on a scale of 0-10, what was your worst IBS-related abdominal pain over the last 24 hours? ‘Zero’ means you have no pain at all; ‘Ten’ means the worst possible pain you can imagine”.*

- at least a 50% reduction in the number of days in a week with a daily stool consistency of Bristol Stool Scale Type 6 or 7 compared with baseline where 6=fluffy pieces with ragged edges, a mushy stool; 7=watery stool, no solid pieces; entirely liquid.

Responders were then followed for recurrence of their IBS-related symptoms of abdominal pain *or* mushy/watery stool consistency for up to 20 treatment-free weeks.

When patients experienced recurrence of their symptoms of abdominal pain *or* mushy/watery stool consistency for 3 weeks of a rolling 4-week period, they were randomized into the double-blind, placebo-controlled repeat treatment phase. Of the 1,074 patients who responded to open-label ZAXINE, 382 experienced a period of symptom inactivity or decrease that did not require repeat treatment by the time they discontinued, including patients who completed the 22 weeks after initial treatment with ZAXINE (see **Error! Reference source not found.**).

Overall, 1,257 of 2,579 patients (49%) were non-responders in the open-label phase and per the study protocol were withdrawn from the study. Other reasons for discontinuation include: patient request (5%), patient lost to follow-up (4%), adverse reaction (3%), and other (0.8%).

There were 1,074 (44%) of 2,438 evaluable patients who responded to initial treatment with improvement in abdominal pain *and* stool consistency. The response rate during the open-label phase for TARGET 3 assessed as a 30% improvement in abdominal pain and an improvement in stool consistency is found to be similar to the rates seen in earlier studies (TARGET 1 and 2) even though a slight difference in responder definitions exists between the studies (see [Table 11](#)).

A total of 636 patients subsequently had sign and symptom recurrence and were randomized to the repeat treatment phase. The median time to recurrence for patients who experienced initial response during the open-label phase with ZAXINE was 10 weeks (range 6 to 24 weeks).

The ZAXINE and placebo treatment groups had similar baseline IBS symptom scores at the time of recurrence and randomization to the double-blind phase, but symptom scores were less severe than at study entry into the open-label phase.

Patients were deemed to have recurrent signs and symptoms by the following criteria: a return of abdominal pain or lack of stool consistency for at least 3 weeks during a 4-week follow-up period. The primary endpoint in the double-blind, placebo-controlled portion of the trial was the proportion of patients who were responders to repeat treatment in both IBS-related abdominal pain *and* stool consistency as defined above during the 4 weeks following the first repeat treatment with ZAXINE. The primary analysis was performed using the worst case analysis method where patients with < 4 days of diary entries in a given week are considered as non-responders for that week.

More patients receiving ZAXINE were monthly responders for abdominal pain *and* stool consistency in the primary analysis in TARGET 3 (see [Table 12](#)).

Table 15: Efficacy Responder Rates in TARGET 3 in a Given Week for at Least 2 Weeks during Weeks 3 to 6 of the Double Blind, First Repeat Treatment Phase (Worst Case Analysis)

Type of Responder	Placebo (n=308) n (%)	ZAXINE (n=328) n (%)	Treatment Difference (95% CI ^a)
Combined Responder ^b : Abdominal Pain and Stool Consistency Responders	77 (25)	107 (33)	8% (0.6%, 14.6%)
Abdominal Pain Responders ^d (≥ 30% reduction in abdominal pain)	130 (42)	166 (51)	8% (0.7%, 16.1%)
Stool Consistency Responders (≥ 50% reduction from baseline in days/week with loose or watery stools)	111 (36)	138 (42)	6% (-1.5%, 13.6%)

^a Confidence Intervals were derived based on CMH test adjusting for center and patients' time to recurrence during maintenance phase.

^b Primary endpoint

^c Subjects were IBS-related abdominal pain and stool consistency responders if they were both weekly IBS-related abdominal pain responders and weekly stool consistency responders in a given week for at least 2 weeks during Weeks 3 to 6 in the double-blind first repeat treatment phase. Weekly responder in IBS-related abdominal pain was defined as a 30% or greater improvement from baseline in the weekly average abdominal pain score. Weekly responder in stool consistency was defined as a 50% or greater reduction in the number of days in a week with stool consistency of type 6 or 7 compared with baseline. The p-value for this composite endpoint was < 0.05.

^d The p-value for responders was < 0.05.

Thirty-six of 308 (11.7%) of placebo patients and 56 of 328 (17.1%) of ZAXINE-treated patients responded to the first repeat treatment and did not have recurrence of signs and symptoms through the treatment-free follow-up period (10 weeks after first repeat treatment, p-value < 0.05). The response rate difference was 5.4% with 95% confidence interval (1.2% to 11.6%).

The overall safety profile during and following treatment and repeat treatment with rifaximin 550 mg TID in subjects with IBS-D was consistent with the population under study, was comparable to that observed with placebo in the double-blind repeat treatment phase, and was comparable to that observed after one 14-day rifaximin treatment course in the open-label phase and with previous Phase 3 studies (TARGET 1 and 2).

Results of the culture and susceptibility testing demonstrate no evidence of development of clinically significant bacterial resistance. There was also no rifaximin-mediated cross-resistance to non-rifamycin antibiotics in response to rifaximin treatment in isolates grown from either stool or skin swab cultures. Importantly, repeat treatment courses of rifaximin do not appear to predispose patients to the emergence of potentially pathogenic bacteria (e.g., *C. difficile*, *Enterococcus*, or *Staphylococcus*) in the stool or on the skin. A very small number of *C. difficile* isolates were identified in stool samples at a rate consistent with literature reports of asymptomatic carriers in the general population, and none of these isolates demonstrated rifaximin resistance.

DETAILED PHARMACOLOGY

ZAXINE (rifaximin) contains rifaximin- α , one of the polymorphic forms of rifaximin.

Mechanism of Action

See ACTION AND CLINICAL PHARMACOLOGY.

ANIMAL PHARMACOLOGY

Pharmacodynamics

The safety pharmacology, neurobehavioral, gastrointestinal, renal, cardiovascular, and neurological effects, were evaluated in mice, rats, cats, and dogs following single oral or intraduodenal doses ranging from 100 to 1000 mg/kg. In mice, rifaximin did not show significant pharmacologic effects on neurobehavior, locomotion, motor coordination, gastrointestinal motility, proconvulsant activity, hexobarbital-induced sleep time, and diazepam-inhibited seizure activity. No significant effects were seen on gastric acid secretion, gastric mucosa, or urinary volume and electrolyte excretion in rats. Rifaximin did not demonstrate significant effects on hemodynamics and respiration in dogs, rats or guinea pigs, or autonomic function in cats. Thus, from the safety pharmacology studies, the no effect level was 1000 mg/kg, equivalent to about 42.4 times greater than the daily therapeutic dose anticipated to be used in IBS-D. When factoring individual animal models this dose level is also about 4-fold (in mouse) to 23-fold (in dog) greater than the human IBS-D therapeutic dose, given that the daily maximum clinical dose is anticipated to be 1650 mg/d which is equivalent to 23.6 mg/kg or 944 mg/m² for a 70 kg subject with 1.7 m² total body surface area.

Pharmacokinetics

Following oral administration of ¹⁴C-rifaximin, the drug is poorly absorbed. Most of the radioactivity was demonstrated in the gastrointestinal tract. Systemic availability of orally administered ¹⁴C-rifaximin (24 mg/kg) was not more than 2-5% of the oral dose in rats or 0.5% of the oral dose in dogs. In rats, the majority of drug activity >96% was demonstrated in faeces, 0.6% in the liver and 0.01% in the kidney. Biliary excretion approximates 0.5% to 1.7% of the oral dose, suggesting that there is a significant first pass removal of rifaximin by the liver, for the small proportion of the oral dose absorbed. In dogs administered with 2.4 mg/kg IV ¹⁴C-rifaximin, the majority of the dose was recovered from faeces (83-93 %) while 0.45% from urine suggesting the faecal radioactivity from IV dose is probably initially excreted in bile. Effect of rifaximin on hepatic and intestinal drug metabolizing enzymes was evaluated *ex vivo* in CD rats. Following 50-300 mg/kg/day administration of rifaximin orally for 26 weeks in rats, rifaximin did not demonstrate significant induction potential in liver/GI tract.

In Vitro Study

In vitro interspecies comparison of metabolism of rifaximin in rat, rabbit, dog and human hepatocytes demonstrated that the rate of metabolism varied and was greatest for rabbit, followed by dog, rat and human. Large interspecies differences were reported in major metabolites formed. Different major metabolites were observed for each species. The major human

metabolite (25-desacetyl rifaximin) was not detected in rat and was demonstrated as a minor metabolite in rabbits and dogs.

HUMAN PHARMACOLOGY

In Vitro Studies

QT/QTc Prolongation

In vitro rifaximin concentrations of $\geq 30 \mu\text{M}$ (23,577 ng/mL) demonstrated a statistically significant increase in inhibition of the hERG channel; the IC_{50} was estimated to be $> 100 \mu\text{M}$ (78590 ng/mL).

Pharmacokinetics

Rifaximin is metabolized by CYP3A4. Multiple rifaximin metabolism pathways were identified, including deacetylation, demethylation, mono-oxidation, and desaturation. The major metabolite observed was 25-desacetyl rifaximin. Rifaximin has low potential to induce CYP3A4 enzyme activity [at a concentration of $0.2 \mu\text{M}$ (157 ng/ml)]. Rifaximin did not inhibit cytochrome P450 isozymes 1A2, 2A6, 2B6, 2C9, 2C19, 2D6, 2E1 and CYP3A4 at concentrations up to 200 ng/ml. However, at higher concentrations rifaximin inhibited CYP 3 A4 [$\text{IC}_{50} = 25 \mu\text{M}$, (19,648 ng/ml) equivalent to 900x the clinical unbound C_{max} in hepatically impaired patients]. Rifaximin is a substrate and a weak inhibitor of P-glycoprotein (P-gp). Rifaximin partly inhibited digoxin transport at $50 \mu\text{M}$ (39,316 ng/ml) through Caco-2 monolayers.

MICROBIOLOGY

Spectrum of Activity

Rifaximin has a broad antimicrobial spectrum.

Development of Resistance

Rifaximin is a structural analog of rifampin. Organisms with high rifaximin minimum inhibitory concentration (MIC) values also have elevated MIC values against rifampin. Cross-resistance between rifaximin and other classes of antimicrobials has not been studied.

Escherichia coli has been shown to develop resistance to rifaximin *in vitro*. However, the clinical significance of such an effect has not been studied.

TOXICOLOGY

Following single-dose toxicity, repeat-dose toxicity, genotoxicity, carcinogenicity and reproductive toxicity studies were conducted to investigate the toxicity of rifaximin.

Single-dose

Single oral doses of up to 2000 mg/kg rifaximin were nontoxic to mice and rats.

Repeat Dose

Oral administration of rifaximin for 3-6 months produced hepatic proliferation of connective tissue in rats (50 mg/kg/day) and fatty degeneration of liver in dogs (100 mg/kg/day). However, plasma drug levels were not measured in these studies. Rifaximin was studied at doses as high as 300 mg/kg/day in rats for 6 months and 1000 mg/kg/day in dogs for 9 months, and no signs of hepatotoxicity were observed. The maximum plasma AUC_{0-8 hr} values from the 6-month rat and 9-month dog toxicity studies (range: 42-127 ng•h/mL) was lower than the maximum plasma AUC_{0-8hr} values in cirrhotic patients (range: 19-306 ng•h/mL).

Repeat oral administration of rifaximin at 1000 mg/kg/d for 39 weeks was nontoxic to the dog. To achieve higher exposures to rifaximin, dogs were given 1000 mg/kg/d of the amorphous form of rifaximin by the oral route. The rate and extent of systemic exposure to rifaximin amorphous form was approximately 90-fold higher than for those administered rifaximin alpha. At week 26, except for orange-colored feces/fur and non-specific stress-induced thymic atrophy/involution, no consistent clinical pathologic or histopathologic changes attributable to rifaximin amorphous were observed in these dogs.

Genotoxicity

Rifaximin did not show evidence of mutagenic activity in a standard battery that included bacterial and yeast gene mutation assays, mammalian CHO/HGPRT gene mutation assay, chromosomal aberration assay with human lymphocytes, and *in vivo* tests e.g., rat bone marrow micronucleus assay. Rifaximin does not induce unscheduled DNA synthesis in primary rat hepatocytes and unscheduled DNA synthesis in rat hepatocytes after *in vivo* treatment.

Carcinogenicity

Malignant schwannomas in the heart were significantly increased in male Crl: CD rats that received rifaximin by oral gavage for two years at 150 to 250 mg/kg/day (doses equivalent to 1.3 to 2.2 times the recommended dose, based on relative body surface area comparisons). There was no increase in tumors in Tg.rasH2 mice dosed orally with rifaximin for 26 weeks at 150 to 2000 mg/kg/day (doses equivalent to 0.7 to 9 times the recommended daily dose based on relative body surface area comparisons).

Reproductive Toxicity and Fertility

In a rat embryofetal development study, a slight and transient delay in ossification that did not affect the normal development of the offspring, was observed at 300 mg/kg/day (equivalent to 2.6 times the clinical dose for hepatic encephalopathy, and approximately 1.8 times the recommended dose for IBS-D (1650 mg per day), adjusted for body surface area). In the rabbit, following oral administration of rifaximin during gestation, an increase in the incidence of skeletal variations was observed (at doses similar to clinical dose). The clinical relevance of these findings is not known. In another study in pregnant rabbits from Gestation Day 6 - 19 following administration of rifaximin 62.5- 1000 mg/kg/d orally for 14 days, rifaximin tissue concentrations were evaluated in the fetal and adult brain and liver, and in the placenta. In pregnant rabbits treated with rifaximin 250 and 1000 mg/kg/d, minimal rifaximin exposure to fetus was demonstrated.

REFERENCES

- Amenta M, Dalle Nogare ER, Colomba C, Prestileo TS, Di Lorenzo F, Fundaro S, Colomba A, Ferrieri A. Intestinal protozoa in HIV-infected patients: Effect of rifaximin in *Cryptosporidium parvum* and *Blastocystis hominis* infections. *J Chemother.* 1999 Oct; 11(5):391-395.
- Arguedas MR, DeLawrence TG and McGuire BM. Influence of hepatic encephalopathy on health-related quality of life in patients with cirrhosis. *Dig Dis Sci* 2003;48:1622.
- Bajaj JS, Schubert CM, Heuman DM, Wade JB, Gibson DP, Topaz A, Saeian K, Hafeezullah M, Bell DE, Sterling RK, Stravitz RT, Luketic V, White MB, Sanyal AJ. Gastroenterology. Persistence of cognitive impairment after resolution of overt hepatic encephalopathy. 2010 Jun;138(7):2332-2340.
- Bajaj JS, Riggio O, Allampati S, Prakash R, Gioia S, Onori E, Piazza N, Noble NA, White MB, Mullen KD. Cognitive dysfunction is associated with poor socioeconomic status in patients with cirrhosis: an international multicenter study. *Clin Gastroenterol Hepatol.* 2013 Nov;11(11):1511-1516.
- Bajaj JS, Wade JB, Gibson DP, Heuman DM, Thacker LR, Sterling RK, Stravitz RT, Luketic V, Fuchs M, White MB, Bell DE, Gilles H, Morton K, Noble N, Puri P, Sanyal AJ. The multi-dimensional burden of cirrhosis and hepatic encephalopathy on patients and caregivers. *Am J Gastroenterol.* 2011 Sep;106(9):1646-1653.
- Barbara G, DeGiorgio R, Stanghellini V, et al. A role for inflammation in irritable bowel syndrome. *Gut* 2002;51(Suppl.1):141-144.
- Bass NM, Mullen KD, Sanyal A et al. Rifaximin Treatment in Hepatic Encephalopathy. *N Eng J Med.* 2010;362:1071-81.
- Bustamante J, Rimola A, Ventura PJ, Navasa M, Cirera I, Reggiardo V, Rodés J. Prognostic significance of hepatic encephalopathy in patients with cirrhosis. *J Hepatol.* 1999 May;30(5):890-895.
- Collins SM. A role for the gut microbiota in IBS. *Nat Rev Gastroenterol Hepatol.* 2014 Aug;11(8):497-505.
- de Melo RT, Charneski L, Hilas O. Rifaximin for the treatment of hepatic encephalopathy. *Am J Health Syst Pharm.* 2008;65(9):818-22.
- Descombe JJ, Dubourg D, Picard M, Palazzini E. Pharmacokinetic Study of Rifaximin after Oral Administration in Healthy Volunteers. *Int J Clin Pharm Res.* 1994;2:51-56.

- D'Amico G, Morabito A, Pagliaro L, Marubini E. Survival and prognostic indicators in compensated and decompensated cirrhosis. *Dig Dis Sci*. 1986 May;31(5):468-475.
- Drossman DA, Li Z, Andruzzi RD, et al. U.S. householder survey of functional gastrointestinal disorders. Prevalence, sociodemography, and health impact. *Dig Dis Sci* 1993;38:1569-1580.
- Farndale R, Roberts L. Long-term impact of irritable bowel syndrome: a qualitative study. *Prim Health Care Res Dev*. 2011;12(1):52-67.
- Fedorak RN, Vanner SJ, Paterson WG, et al. Canadian Digestive Health Foundation Public Impact Series 3: Irritable bowel syndrome in Canada. Incidence, prevalence, and direct and indirect economic impact. *Can J Gastroenterol*. 2012 May;26(5):252-256.
- Fera G, Francesco A, Michele N, Oronzo S, Antonella F. Rifaximin for the treatment of hepatic encephalopathy. *Eur J Clinical Res*. 1993;4:57-66.
- Festi D, Mazzella G, Orsini M, et al. Rifaximin in the treatment of chronic hepatic encephalopathy: Results of a multicenter study of efficacy and safety. *Curr Ther Res*. 1993;54:598-609.
- Gao J1, Gilliland MG 3rd1, Owyang C1. Rifaximin, gut microbes and mucosal inflammation: unraveling a complex relationship. *Gut Microbes* 2014 Jul 1;5(4):571-575.
- Hoffman JT, Hartig C, Sonbol E, Lang M. Probable interaction between warfarin and rifaximin in a patient treated for small intestine bacterial overgrowth. *Annals Pharmacother*. 2011;45: e25.
- Keohane J, O'Mahony C, O'Mahony L, et al. Irritable bowel syndrome-type symptoms in patients with inflammatory bowel disease: A real association or reflection of occult inflammation? *Am J Gastroenterol* 2010;105:1788-1794.
- Lawrence KR, Klee JA. Rifaximin for the treatment of hepatic encephalopathy. *Pharmacotherapy*. 2008;28(8):1019-32.
- Loguercio C, Federico A, De Girolamo V, Ferrieri A, Del Vecchio Blanco C. Cyclic treatment of chronic hepatic encephalopathy with rifaximin. Results of a double-blind clinical study. *Minerva Gastroenterol Dietol*. 2003;49:53-62.
- Longstreth GF, Thompson WG, Chey WD et al. Functional bowel disorders. *Gastroenterology* 2006;130:1480-1491.
- Ma X, Shah YM, Guo GL, Wang T, Krausz KW, Idle JR, Gonzalez FJ. Rifaximin is a gut-specific human pregnane X receptor activator. *J Pharmacol Exp Ther*. 2007 Jul;322(1):391-8.
- McCrea M, Cordoba J, Vessey G, Blei AT, Randolph C. Neuropsychological characterization and detection of subclinical hepatic encephalopathy. *Arch Neurol*. 1996;53:758-763.

Mencarelli A, Renga B, Palladino G, Claudio D, Ricci P, Distrutti E, Barbanti M, Baldelli F, Fiorucci S. Inhibition of NF- κ B by a PXR-dependent pathway mediates counter-regulatory activities of rifaximin on innate immunity in intestinal epithelial cells. *Eur J Pharmacol.* 2011 Oct 1; 668(1-2):317-324.

Methods for Dilution Antimicrobial Susceptibility Tests for Bacteria that Grow Aerobically; Approved Standard Ninth Edition. CLSI document M07-A9. Wayne, PA: Clinical and Laboratory Standards Institute, 2012.

Methods for Antimicrobial Susceptibility Testing of Anaerobic Bacteria; Approved Standard Eighth Edition. CLSI document M11-A8. Wayne, PA: Clinical and Laboratory Standards Institute, 2012.

Miglio F, Valpiani D, Rossellini SR, Ferrieri A. Rifaximin, a non-absorbable rifamycin, for treatment of hepatic encephalopathy. A double-blind, randomized trial. *Curr Med Res Opin.* 1997;13:593-601.

Mullen KD, Sanyal AJ, Bass NM, Poordad FF, Sheikh MY, Frederick RT, Bortey E, Forbes WP. Rifaximin is safe and well tolerated for long-term maintenance of remission from overt hepatic encephalopathy. *Clin Gastroenterol Hepatol.* 2014 Aug;12(8):1390-1397.e2.

Muscattello MR, Bruno A, Pandolfo G, Mico U, Stilo S, Scaffidi M, et al. Depression, anxiety and anger in subtypes of irritable bowel syndrome patients. *J Clin Psychol Med Settings.* 2010;17(1):64-70.

Ong JP, Aggarwal A, Krieger D, Easley KA, Karafa MT, and Van Lente F, et al. Correlation between ammonia levels and the severity of hepatic encephalopathy. *Am J Med.* 2003;114:188-93.

Pace F, Molteni P, Bollani S, Sarzi-Puttini P, Stockbrugger R, Bianchi Porro G, et al. Inflammatory bowel disease versus irritable bowel syndrome: a hospital-based, case-control study of disease impact on quality of life. *Scand J Gastroenterol.* 2003;38(10):1031-1038.

Performance Standards for Antimicrobial Susceptibility Testing; Twenty-Fourth Informational Supplement. CLSI document M100-S2. Wayne, PA: Clinical and Laboratory Standards Institute, 2014.

Pimentel M, Chow EJ, Lin HC. Eradication of small intestinal bacterial overgrowth reduces symptoms of irritable bowel syndrome. *Am J Gastroenterol* 2000;95:3503-3506.

Posserud I, Stotzer PO, Bjornsson ES, et al. Small intestinal bacterial overgrowth in patients with irritable bowel syndrome. *Gut* 2007;56:802-808.

Pylaris E, Giamarellos-Bourboulis EJ, Tzivras D, et al. The prevalence of overgrowth by aerobic bacteria in the small intestine by small bowel culture: relationship with irritable bowel syndrome. *Dig Dis Sci* 2012;57:1321-1329.

Quigley EM1, Fried M, Gwee KA, Khalif I, Hungin AP, Lindberg G, Abbas Z, Fernandez LB, Bhatia SJ, Schmulson M, Olano C, LeMair A; World Gastroenterology Organisation Global Guidelines Irritable Bowel Syndrome: A Global Perspective Update September 2015. *J Clin Gastroenterol*. 2016 Oct;50(9):704-713.

Romero-Gómez M1, Boza F, García-Valdecasas MS, García E, Aguilar-Reina J. Subclinical hepatic encephalopathy predicts the development of overt hepatic encephalopathy. *Am J Gastroenterol*. 2001 Sep;96(9):2718-2723.

Sanyal A, Younossi ZM, Bass NM, et al. Randomised clinical trial: rifaximin improves health-related quality of life in cirrhotic patients with hepatic encephalopathy - a double-blind placebo-controlled study. *Aliment Pharmacol Ther*. 2011;34(8):853-61.

Scarpignato C, Pelosini I. Rifaximin, a poorly absorbed antibiotic: pharmacology and clinical potential. *Chemotherapy*. 2005; 51 Suppl 1():36-66.

Talley NJ, Zinsmeister AR, Van Dyke C, Melton LJ 3rd. Epidemiology of colonic symptoms and the irritable bowel syndrome. *Gastroenterology*. 1991 Oct;101(4):927-934.

Thompson WG, Irvine EJ, Pare P, et al. Functional gastrointestinal disorders in Canada: first population-based survey using Rome II criteria with suggestions for improving the questionnaire. *Dig Dis Sci*. 2002 Jan;47(1):225-235.

Umezawa H, Mizuno S, Yamazaki H, Nitta K. Inhibition of DNA-dependent RNA synthesis by rifamycins. *J Antibiot (Tokyo)*. 1968 Mar; 21(3):234-236.

Verardi S, Verardi V. Bile rifaximin concentration after oral administration in patients undergoing cholecystectomy. *Farmaco*. 1990;45(1):131-135.

Vilstrup H, Amodio P, Bajaj J, Cordoba J, Ferenci P, Mullen KD, Weissenborn K, Wong P. Hepatic encephalopathy in chronic liver disease: 2014 practice guideline by the European Association for the Study of the Liver and the American Association for the Study of Liver Diseases. *J Hepatol*. 2014 Sep;61(3):642-659.

Whitehead WE, Burnett CK, Cook E3, Taub E. Impact of irritable bowel syndrome on quality of life. *Dig Dis Sci*.1996;41(11):2248-2253.

Williams R, Bass N. Rifaximin, a nonabsorbed oral antibiotic, in the treatment of hepatic encephalopathy: Antimicrobial activity, efficacy, and safety. *Rev Gastroenterol Disord* 2005;5(suppl 1):S10-S18.

Xu D1, Gao J1, Gilliland M 3rd1, Wu X1, Song I1, Kao JY1, Owyang C2. Rifaximin alters intestinal bacteria and prevents stress-induced gut inflammation and visceral hyperalgesia in rats. *Gastroenterology* 2014 Feb;146(2):484-496.e4.

Zeneroli ML, Avallone R, Corsi L, Venturini I, Baraldi C, Baraldi M. Management of hepatic encephalopathy: role of rifaximin. *Chemotherapy*. 2005;51 Suppl 1:90-5.

PART III: CONSUMER INFORMATION**PrZAXINE
rifaximin tablets**

This leaflet is part III of a three-part "Product Monograph" published when ZAXINE was approved for sale in Canada and is designed specifically for Consumers. This leaflet is a summary and will not tell you everything about ZAXINE. Contact your doctor or pharmacist if you have any questions about the drug.

ABOUT THIS MEDICATION**What the medication is used for:**

ZAXINE is an antibiotic that acts on the bacteria in the gut.

Hepatic Encephalopathy

ZAXINE is used to help prevent recurring episodes of a condition called **hepatic encephalopathy (HE)**. It may be used in conjunction with lactulose, as directed by your doctor. HE occurs when the liver is not working properly and cannot remove toxins from the blood which affect brain function.

ZAXINE is intended to be used for preventing HE only in those adult patients where HE is likely to occur again.

Antibacterial drugs like ZAXINE treat only bacterial infections. They do not treat viral infections.

Irritable Bowel Syndrome with Diarrhea

ZAXINE is used to treat **irritable bowel syndrome with diarrhea (IBS-D)** in adults.

What it does:**Hepatic Encephalopathy**

ZAXINE is thought to work by reducing the production of toxins released into the blood by bacteria in the gut.

Irritable Bowel Syndrome with Diarrhea

ZAXINE is thought to work by reducing the amount of bacteria and bacterial products in the gut. This can help with the most common symptoms of IBS-D which include bloating, abdominal pain and diarrhea.

When it should not be used:

If you are allergic (hypersensitive) to the active substance rifaximin, rifamycin antibacterial agents, or any of the other ingredients of ZAXINE (see **What the nonmedicinal ingredients are**).

What the medicinal ingredient is:

The active substance is rifaximin.

What the nonmedicinal ingredients are:

colloidal silicon dioxide, glyceryl distearate, microcrystalline cellulose, polyethylene glycol, polyvinyl alcohol, red iron oxide, gluten-free sodium starch glycolate, talc, and titanium dioxide.

What dosage forms it comes in:

Tablets: 550 mg

WARNINGS AND PRECAUTIONS

BEFORE you use ZAXINE talk to your doctor or pharmacist if:

- You have severe liver problems – there is an increase in systemic (blood) exposure to rifaximin in subjects with severe liver disease.
- You have any allergies to this drug or its ingredients.
- You are pregnant or think you may be pregnant, ask your doctor or pharmacist for advice before taking this medicine. Your doctor can discuss with you the risks and benefits involved.
- You are breastfeeding ask your doctor or pharmacist for advice before taking this medicine. It is not known whether rifaximin passes into breast milk.
- ZAXINE should not be used in children or adolescents less than 18 years of age, as there is no information on the use in that population.

INTERACTIONS WITH THIS MEDICATION

Tell your doctor or pharmacist if you are using, have recently used, or might use any other medicines, including non-prescription or herbal medicines. Tell your doctor if you are taking warfarin or oral contraceptives.

PROPER USE OF THIS MEDICATION

ZAXINE can be taken with or without food.

ZAXINE tablets should be swallowed whole with plenty of water. Do not crush tablets.

Although you may feel better early in treatment, ZAXINE should be used exactly as directed.

Do not misuse or overuse ZAXINE.

Do not share your medicine.

Usual adult dose:**Hepatic Encephalopathy**

The recommended dosage is one tablet twice daily.

Irritable Bowel Syndrome with Diarrhea

The recommended dosage is one tablet three times a day for 14 days. If your symptoms come back, your doctor may consider retreatment when needed.

Overdose:

In case of drug overdose, contact a health professional, hospital emergency department or regional Poison Control Centre immediately, even if there are no symptoms.

Missed Dose:

If you forget to take a dose, it should be taken as soon as possible. However, if it is almost time for the next dose, no additional dose should be taken and the regular dosing schedule should be resumed.

If you are taking ZAXINE for Hepatic Encephalopathy:
No more than two doses of ZAXINE (1 tablet twice a day) should be taken in a 24-hour period.

If you are taking ZAXINE for Irritable Bowel Syndrome with Diarrhea:

No more than three doses of ZAXINE (1 tablet three times a day) should be taken in a 24-hour period.

If you have trouble remembering to take your medicine, ask your pharmacist for some hints.

SIDE EFFECTS AND WHAT TO DO ABOUT THEM

Like all medicines, this medicine can cause side effects, although not everybody gets them. The most common side effects reported with ZAXINE are:

- Diarrhea
- Nausea
- Vomiting
- Abdominal pain or bloating
- Muscle spasms
- Dizziness or unsteadiness
- Headache
- Itchiness

ZAXINE may cause a reddish discolouration of the urine, tears and sweat.

ZAXINE can cause abnormal blood test results. Your doctor will decide when to perform blood tests and will interpret the results.

If you get any side effects, talk to your doctor or pharmacist. This includes any possible side effects not listed in this leaflet.

SERIOUS SIDE EFFECTS, HOW OFTEN THEY HAPPEN AND WHAT TO DO ABOUT THEM

Symptom / effect		Talk with your doctor or pharmacist		Stop taking drug and get immediate medical help
		Only if severe	In all cases	
Unknown	Allergic Reaction: rash, hives, swelling of the face, lips, tongue or throat, difficulty swallowing or breathing			√
Rare	Clostridium difficile colitis (gut inflammation): severe diarrhea (bloody or watery) with or without fever, abdominal pain, or tenderness		√	

This is not a complete list of side effects. For any unexpected effects while taking ZAXINE, contact your doctor or pharmacist.

HOW TO STORE IT

Keep this medicine out of the sight and reach of children.

Do not use this medicine after the expiry date which is stated on the bottle, after “EXP:”. The expiry date refers to the last day of that month.

ZAXINE should be stored at room temperature (15°C to 30°C) in a tightly closed container away from heat and direct light.

Medicines should not be disposed of via wastewater or household waste. Ask your pharmacist how to throw away medicines you no longer use. These measures will help to protect the environment.

Reporting Side Effects

You can report any suspected side effects associated with the use of health products to Health Canada by:

- Visiting the Web page on Adverse Reaction Reporting (<https://www.canada.ca/en/health-canada/services/drugs-health-products/medeffect-canada/adverse-reaction-reporting.html>) for information on how to report online, by mail or by fax; or
- Calling toll-free at 1-866-234-2345.

NOTE: Contact your healthcare professional if you need information about how to manage your side effects. The Canada Vigilance Program does not provide medical advice.

MORE INFORMATION

This document plus the full product monograph, prepared for health professionals can be found at the Health Canada website www.canada.ca/en/health-canada.html; the manufacturer's website www.bauschhealth.com, the importer website www.lupinpharma.ca or by calling 1-844-587-4623.

This leaflet was prepared by Salix Pharmaceuticals, Inc., a division of Valeant Pharmaceuticals North America LLC.

Licensed from: Alfasigma S.p.A.

Distributed by:
Lupin Pharma Canada Limited
Montreal, QC, H2L 4P9

Manufactured for:
Salix Pharmaceuticals, Inc.
Bridgewater, NJ 08807 USA

Last revised: February 11, 2019

PRODUCT MONOGRAPH

Pr **ZYTIGA**[®]

Abiraterone acetate tablets, Mfr. Std.

250 mg uncoated tablets, 500 mg film-coated tablets

Androgen Biosynthesis Inhibitor

Janssen Inc.
19 Green Belt Drive
Toronto, Ontario
M3C 1L9
www.janssen.com/canada

Date of Preparation:
July 26, 2011

Date of Revision:
September 22, 2020

Submission Control No.: 236834

All trademarks used under license.

© 2020 Janssen Inc.

Table of Contents

PART I: HEALTH PROFESSIONAL INFORMATION..... 3

SUMMARY PRODUCT INFORMATION 3

INDICATIONS AND CLINICAL USE..... 3

CONTRAINDICATIONS 3

WARNINGS AND PRECAUTIONS..... 4

ADVERSE REACTIONS..... 7

DRUG INTERACTIONS 16

DOSAGE AND ADMINISTRATION 18

OVERDOSAGE 19

ACTION AND CLINICAL PHARMACOLOGY 19

STORAGE AND STABILITY..... 22

SPECIAL HANDLING INSTRUCTIONS 22

DOSAGE FORMS, COMPOSITION AND PACKAGING 22

PART II: SCIENTIFIC INFORMATION 23

PHARMACEUTICAL INFORMATION..... 23

CLINICAL TRIALS..... 23

DETAILED PHARMACOLOGY 41

TOXICOLOGY 42

REFERENCES 44

PART III: CONSUMER INFORMATION..... 45

Pr ZYTIGA®

Abiraterone acetate tablets, Mfr. Std.

250 mg uncoated tablets, 500 mg film-coated tablets

Androgen Biosynthesis Inhibitor

PART I: HEALTH PROFESSIONAL INFORMATION

SUMMARY PRODUCT INFORMATION

Route of Administration	Dosage Form / Strength	Clinically Relevant Nonmedicinal Ingredients
Oral	Tablet 250 mg uncoated, 500 mg film-coated	Lactose monohydrate <i>For a complete listing see DOSAGE FORMS, COMPOSITION AND PACKAGING section.</i>

INDICATIONS AND CLINICAL USE

ZYTIGA® is indicated in combination with prednisone for the treatment of metastatic prostate cancer (castration-resistant prostate cancer, mCRPC) in patients who:

- are asymptomatic or mildly symptomatic after failure of androgen deprivation therapy
- have received prior chemotherapy containing docetaxel after failure of androgen deprivation therapy

ZYTIGA® is also indicated in combination with prednisone and androgen deprivation therapy (ADT) for the treatment of patients with newly diagnosed hormone-sensitive high-risk metastatic prostate cancer who may have received up to 3 months of prior ADT.

Geriatrics (≥ 65 years of age):

In the Phase 3 studies of ZYTIGA®, 70% of patients were 65 years and over, and 27% of patients were 75 years and over. No overall differences in safety or effectiveness were observed between these elderly patients and younger patients (see **WARNINGS AND PRECAUTIONS, Special Populations, Geriatrics**).

Pediatrics:

ZYTIGA® has not been studied in children.

CONTRAINDICATIONS

- Patients who are hypersensitive to this drug or to any ingredient in the formulation or component of the container. For a complete listing, see the **DOSAGE FORMS, COMPOSITION AND PACKAGING** section of the Product Monograph.
- Women who are or may potentially be pregnant.

WARNINGS AND PRECAUTIONS

Serious Warnings and Precautions

- ZYTIGA[®] may cause hypertension, hypokalemia and fluid retention due to mineralocorticoid excess (see **WARNINGS AND PRECAUTIONS, Cardiovascular**)
- ZYTIGA[®] should be used with caution in patients with a history of cardiovascular disease (for specific conditions see **WARNINGS AND PRECAUTIONS, Cardiovascular**)
- Patients with severe and moderate hepatic impairment should not receive ZYTIGA[®] (see **WARNINGS AND PRECAUTIONS, Special Populations, Patients with Hepatic Impairment**)
- Hepatotoxicity, including fatal cases has been observed (see **WARNINGS AND PRECAUTIONS, Hepatic**)

General

Gonadotropin releasing hormone (GnRH) agonists must be taken during treatment with ZYTIGA[®] or patients must have been previously treated with orchiectomy.

ZYTIGA[®] must be taken on an empty stomach. No solid or liquid food should be consumed for at least two hours before the dose of ZYTIGA[®] is taken and for at least one hour after the dose of ZYTIGA[®] is taken. Abiraterone C_{max} and AUC_{0-∞} (exposure) were increased up to 17- and 10-fold higher, respectively, when a single dose of abiraterone acetate was administered with a meal compared to a fasted state. The safety of these increased exposures when multiple doses of abiraterone acetate are taken with food has not been assessed (see **DRUG INTERACTIONS Drug-Food Interactions, DOSAGE AND ADMINISTRATION, and ACTION AND CLINICAL PHARMACOLOGY**).

Reproductive Toxicology

In fertility studies in both male and female rats, abiraterone acetate reduced fertility, which was completely reversible in 4 to 16 weeks after abiraterone acetate was stopped. In a developmental toxicity study in the rat, abiraterone acetate affected pregnancy including reduced fetal weight and survival. Effects on the external genitalia were observed though abiraterone acetate was not teratogenic. In these fertility and developmental toxicity studies performed in the rat, all effects were related to the pharmacological activity of abiraterone (see **TOXICOLOGY, Reproductive Toxicology**).

Carcinogenesis and Mutagenesis

Abiraterone acetate was not carcinogenic in a 6-month study in the transgenic (Tg.rasH2) mouse. In a 24-month carcinogenicity study in the rat, abiraterone acetate increased the incidence of interstitial cell neoplasms in the testes. This finding is considered related to the pharmacological action of abiraterone. The clinical relevance of this finding is not known. Abiraterone acetate was not carcinogenic in female rats (see **TOXICOLOGY, Carcinogenesis and Genotoxicity**).

Abiraterone acetate and abiraterone were devoid of genotoxic potential in the standard panel of *in vitro* and *in vivo* genotoxicity tests (see **TOXICOLOGY, Carcinogenesis and Genotoxicity**).

Cardiovascular

ZYTIGA[®] should be used with caution in patients with a history of cardiovascular disease. The safety of ZYTIGA[®] in patients with myocardial infarction, or arterial thrombotic events in the past 6 months, severe or unstable angina, or left ventricular ejection fraction (LVEF) <50% or New York Heart Association Class III or IV heart failure (in patients with mCRPC with prior treatment with docetaxel) or NYHA Class II to IV heart failure (in patients with asymptomatic or mildly symptomatic mCRPC, or newly diagnosed high-risk metastatic prostate cancer) has not been established because these patients were excluded from the pivotal studies.

Hypertension, Hypokalemia and Fluid Retention Due to Mineralocorticoid Excess

Before treatment with ZYTIGA[®], hypertension must be controlled, and hypokalemia must be corrected.

ZYTIGA[®] may cause hypertension, hypokalemia and fluid retention (see **ADVERSE REACTIONS**) as a consequence of increased mineralocorticoid levels resulting from CYP17 inhibition (see **ACTION AND CLINICAL PHARMACOLOGY, Mechanism of Action**). Co-administration of a corticosteroid suppresses adrenocorticotropic hormone (ACTH) drive, resulting in a reduction in the incidence and severity of these adverse reactions. Caution is required in treating patients whose underlying medical conditions might be compromised by potential increases in blood pressure, hypokalemia or fluid retention, e.g., those with heart failure, recent myocardial infarction or ventricular arrhythmia. In post marketing experience, QT prolongation and Torsades de Pointes have been observed in patients who develop hypokalemia or have underlying cardiovascular conditions while taking ZYTIGA[®]. Blood pressure, serum potassium and fluid retention should be monitored at least monthly (see **Monitoring and Laboratory Tests**).

Corticosteroid Withdrawal and Coverage of Stress Situations

Caution is advised if patients need to be withdrawn from prednisone. Monitoring for adrenocortical insufficiency should occur. If ZYTIGA[®] is continued after corticosteroids are withdrawn, patients should be monitored for symptoms of mineralocorticoid excess.

In patients on prednisone who are subjected to unusual stress (e.g., surgery, trauma or severe infections), increased dosage of a corticosteroid may be indicated before, during and after the stressful situation.

Hepatic

Hepatic impairment

ZYTIGA[®] should not be used in patients with pre-existing moderate or severe hepatic impairment (see **WARNINGS AND PRECAUTIONS, Special Populations**, and **Monitoring and Laboratory Tests**, and **ACTION AND CLINICAL PHARMACOLOGY**).

Hepatotoxicity

Cases of acute liver failure and hepatitis fulminant (including fatal outcomes) have been reported during post-marketing experience (see **WARNINGS AND PRECAUTIONS, Serious Warnings and Precautions**, and **ADVERSE REACTIONS, Post-Market Adverse Drug Reactions**).

Marked increases in liver enzymes leading to drug discontinuation or dosage modification occurred in controlled clinical studies (see **ADVERSE REACTIONS**). Serum transaminases (ALT and AST) and bilirubin levels should be measured prior to starting treatment with ZYTIGA[®], every two weeks for the first three months of treatment, and monthly thereafter. Promptly measure serum total bilirubin and serum transaminases (ALT and AST), if clinical symptoms or signs suggestive of hepatotoxicity develop. If at any time the serum transaminases (ALT or AST) rise above 5 times the upper limit of normal or the bilirubin rises above 3 times the upper limit of normal, treatment with ZYTIGA[®] should be interrupted immediately and liver function closely monitored.

Re-treatment with ZYTIGA[®] may only take place after the return of liver function tests to the patient's baseline and at a reduced dose level (see **DOSAGE AND ADMINISTRATION**).

Permanently discontinue ZYTIGA[®] for patients who develop a concurrent elevation of ALT greater than 3 times the upper limit of normal **and** total bilirubin greater than 2 times the upper limit of normal in the absence of biliary obstruction or other causes responsible for the concurrent elevation (see **DOSAGE AND ADMINISTRATION**).

If patients develop severe hepatotoxicity (ALT or AST 20 times the upper limit of normal) anytime while on therapy, ZYTIGA[®] should be discontinued and patients should not be re-treated with ZYTIGA[®].

Use with Chemotherapy

The safety and efficacy of concomitant use of ZYTIGA[®] with cytotoxic chemotherapy has not been established.

Use in Combination with radium 223 dichloride

In a randomized clinical trial in patients with asymptomatic or mildly symptomatic bone-predominant metastatic castration resistant prostate cancer with bone metastases, the addition of radium 223 dichloride to ZYTIGA[®] plus prednisone/prednisolone showed an increase in mortality and an increased rate of fracture. Radium 223 dichloride is not recommended for use in combination with ZYTIGA[®] plus prednisone/prednisolone outside of clinical trials.

Skeletal Muscle Effects

Cases of myopathy have been reported in patients treated with ZYTIGA[®]. Some patients had rhabdomyolysis with renal failure. Most cases developed within the first month of treatment and recovered after ZYTIGA[®] withdrawal. Caution is recommended in patients concomitantly treated with drugs known to be associated with myopathy/rhabdomyolysis.

Special Populations

Pregnant Women: ZYTIGA[®] is contraindicated in women who are or may potentially be pregnant (see **CONTRAINDICATIONS** and **TOXICOLOGY, Reproductive Toxicology**).

There are no human data on the use of ZYTIGA[®] in pregnancy and ZYTIGA[®] is not for use in women of child-bearing potential. Maternal use of a CYP17 inhibitor is expected to produce changes in hormone levels that could affect development of the fetus (see **CONTRAINDICATIONS**). Based on animal studies, there is potential of fetal harm (see **TOXICOLOGY, Reproductive Toxicology**).

It is not known if abiraterone or its metabolites are present in semen. A condom is required if the

patient is engaged in sexual activity with a pregnant woman. If the patient is engaged in sex with a woman of child-bearing potential, a condom is required along with another effective contraceptive method. These measures are required during and for one week after treatment with ZYTIGA[®].

To avoid inadvertent exposure, women who are pregnant or women who may be pregnant should not handle ZYTIGA[®] 250 mg uncoated tablets without protection, e.g., gloves.

Nursing Women: ZYTIGA[®] is not for use in women. It is not known if either abiraterone acetate or its metabolites are excreted in human breast milk.

Pediatrics (< 18 years of age): ZYTIGA[®] has not been studied in children.

Geriatrics (> 65 years of age): In the Phase 3 studies of ZYTIGA[®], 70% of patients were 65 years and over, and 27% of patients were 75 years and over. No overall differences in safety or effectiveness were observed between these elderly patients and younger patients.

Patients with Hepatic Impairment: Patients with pre-existing moderate or severe hepatic impairment should not receive ZYTIGA[®]. ZYTIGA[®] has not been studied in mCRPC patients with moderate or severe (Child-Pugh Class B or C) hepatic impairment at baseline. For patients who develop hepatotoxicity during treatment, suspension of treatment and dosage adjustment may be required (see **WARNINGS AND PRECAUTIONS, DOSAGE AND ADMINISTRATION** and **ACTION AND CLINICAL PHARMACOLOGY, Special Populations and Conditions**).

Patients with Renal Impairment: No dosage adjustment is necessary for patients with renal impairment (see **DOSAGE AND ADMINISTRATION**).

Monitoring and Laboratory Tests

Serum transaminases and bilirubin should be measured prior to starting treatment with ZYTIGA[®], every two weeks for the first three months of treatment and monthly thereafter.

Blood pressure, serum potassium and fluid retention should be monitored monthly (see **WARNINGS AND PRECAUTIONS**). For patients taking 5 mg/day of prednisone, if hypokalemia persists despite optimal potassium supplementation and adequate oral intake, or if any of the other mineralocorticoid effects persist, the dose of prednisone may be increased to 10 mg/day.

Caution is advised if patients need to be withdrawn from prednisone. Monitoring for adrenocortical insufficiency should occur. If ZYTIGA[®] is continued after corticosteroids are withdrawn, patients should be monitored for symptoms of mineralocorticoid excess (see **WARNINGS AND PRECAUTIONS, Corticosteroid Withdrawal and Coverage of Stress Situations**).

ADVERSE REACTIONS

Adverse Drug Reaction Overview

In combined data from Phase 3 trials, the adverse reactions seen with ZYTIGA[®] in ≥10% of patients were hypertension (21%), peripheral edema (19%), hypokalemia (18%), and alanine aminotransferase (ALT) increased and/or aspartate aminotransferase (AST) increased (13%).

The most common adverse reactions leading to dose interruption, reduction, or other modification in patients treated with ZYTIGA[®] versus placebo were hypokalemia (3% vs. 1%), hypertension (3% vs. 1%), AST elevation (2% vs. 1%), and ALT elevation (2% vs. 1%), and hepatic functional abnormal (2% vs. <1%). The most common adverse drug reactions that resulted in drug discontinuation in patients treated with ZYTIGA[®] were ALT increased, AST increased and hypokalemia (<1% each).

The most common serious adverse reactions ($\geq 1\%$) observed with ZYTIGA[®] compared to placebo were pneumonia (2% vs. 1%) and urinary tract infection (2% vs. 1%).

ZYTIGA[®] may cause hypertension, hypokalemia and fluid retention as a pharmacodynamic consequence of its mechanism of action. In Phase 3 studies, anticipated mineralocorticoid effects were seen more commonly in patients treated with ZYTIGA[®] versus patients treated with placebo: hypokalemia (18% vs. 8%), hypertension (22% vs. 16%) and fluid retention (peripheral edema) (23% vs. 17%), respectively. In patients treated with ZYTIGA[®] versus patients treated with placebo, Grades 3 and 4 hypokalemia were observed in 6% versus 1% of patients, Grades 3 and 4 hypertension were observed in 7% versus 5%, and Grades 3 and 4 fluid retention edema were observed in 1% versus 1% of patients, respectively. A higher incidence of hypertension and hypokalemia was observed in Study 3011 (see Study Tables 1-6 below). Generally, these effects due to mineralocorticoid excess were successfully managed medically. Concomitant use of a corticosteroid reduces the incidence and severity of these adverse drug reactions (see **WARNINGS AND PRECAUTIONS**).

Clinical Trial Adverse Drug Reactions

Because clinical trials are conducted under very specific conditions the adverse reaction rates observed in the clinical trials may not reflect the rates observed in practice and should not be compared to the rates in the clinical trials of another drug. Adverse drug reaction information from clinical trials is useful for identifying drug-related adverse events and for approximating rates.

Placebo-controlled Phase 3 Study in Asymptomatic or Mildly Symptomatic mCRPC Patients (Study 302)

In a placebo-controlled, multicentre Phase 3 clinical study of asymptomatic or mildly symptomatic patients with mCRPC who were using a GnRH agonist or were previously treated with orchiectomy, ZYTIGA[®] was administered at a dose of 1 g daily in combination with low dose prednisone (10 mg daily) in the active treatment arm. Placebo plus low dose prednisone (10 mg daily) was given to control patients. The median duration of treatment with ZYTIGA[®] was 18.8 months and 11.3 months for placebo.

The most common all grade adverse reactions observed with ZYTIGA[®] compared to placebo were joint pain or discomfort (32% vs. 27%), peripheral edema (25% vs. 20%), hot flush (22% vs. 18%), diarrhea (22% vs. 18%), hypertension (22% vs. 13%), cough (17% vs. 14%), hypokalemia (17% vs. 13%), upper respiratory tract infection (13% vs. 8%), dyspepsia (11% vs. 5%), hematuria (10% vs. 6%), nasopharyngitis (11% vs. 8%), vomiting (13% vs. 11%), fatigue (39% vs. 34%), constipation (23% vs. 19%), contusion (13% vs. 9%), insomnia (14% vs. 11%), anemia (11% vs. 9%) and dyspnea (12% vs. 10%).

The most common serious adverse drug reactions observed with ZYTIGA[®] compared to placebo was urinary tract infection (1.5% vs. 0.6%), hypokalemia (0.4% vs. 0.2%) and hematuria (1.8% vs. 0.7%).

The most common adverse reactions leading to clinical intervention with ZYTIGA[®] compared to placebo were AST elevation (4.2% vs. 0.6%), and ALT elevation (5.2% vs. 0.7%). Anticipated mineralocorticoid effects were seen more commonly in patients treated with ZYTIGA[®] versus patients treated with placebo: hypokalemia (17% vs. 13%), hypertension (22% vs. 13%) and fluid retention (peripheral edema) (25% vs. 20%), respectively. In patients treated with ZYTIGA[®], Grades 3 and 4 hypokalemia and Grades 3 and 4 hypertension were observed in 2% and 4% of patients, respectively.

Table 1: Adverse Drug Reactions that Occurred in the Phase 3 Study with Asymptomatic or Mildly Symptomatic mCRPC Patients (Study 302) in $\geq 2\%$ (all Grades) of Patients in the ZYTIGA[®] Group

System Organ Class / MedDRA Preferred Term (PT)	ZYTIGA [®] 1 g with Prednisone 10 mg Daily N=542			Placebo with Prednisone 10 mg Daily N=540		
	All Grades (%)	Grade 3 (%)	Grade 4 (%)	All Grades (%)	Grade 3 (%)	Grade 4 (%)
Cardiac Disorders						
Cardiac failure ^a	10 (1.9%)	4 (0.8%)	1 (0.2%)	1 (0.2%)	0	0
Angina pectoris ^b	14 (2.6%)	2 (0.4%)	0	6 (1.1%)	2 (0.4%)	0
General Disorders and Administrative Site Conditions						
Edema peripheral	134 (24.7%)	2(0.4%)	0	108 (20.0%)	5 (0.9%)	0
Fatigue	212 (39.1%)	12 (2.2%)	0	185 (34.3%)	9 (1.7%)	0
Gastrointestinal Disorders						
Diarrhea	117 (21.6%)	5 (0.9%)	0	96 (17.8%)	5 (0.9%)	0
Dyspepsia	60 (11.1%)	0	0	27 (5.0%)	1 (0.2%)	0
Constipation	125 (23.1%)	2 (0.2%)	0	103 (19.1%)	3 (0.6%)	0
Vomiting	69 (12.7%)	4 (0.7%)	0	58 (10.7%)	0	0
Infections and Infestations						
Upper respiratory tract infection	69 (12.7%)	0	0	43 (8.0%)	0	0
Nasopharyngitis	58 (10.7%)	0	0	44 (8.1%)	0	0
Injury, Poisoning and Procedural Complications						
Contusion	72 (13.3%)	0	0	49 (9.1%)	0	0
Fall	32 (5.9%)	0	0	18 (3.3%)	0	0
Musculoskeletal and Connective Tissue Disorders						
Joint pain or discomfort ^c	172 (31.7%)	11 (2.0%)	0	144 (26.7%)	11 (2.0%)	0
Metabolism and Nutrition Disorders						
Hypokalemia	91 (16.8%)	12 (2.2%)	1 (0.2%)	68 (12.6%)	10 (1.9%)	0
Skin and Subcutaneous Tissue Disorders						
Rash	44 (8.1%)	0	0	20 (3.7%)	0	0
Skin lesion	19 (3.5%)	0	0	5 (0.9%)	0	0
Psychiatric Disorders						

	ZYTIGA [®] 1 g with Prednisone 10 mg Daily N=542			Placebo with Prednisone 10 mg Daily N=540		
System Organ Class / MedDRA Preferred Term (PT)	All Grades (%)	Grade 3 (%)	Grade 4 (%)	All Grades (%)	Grade 3 (%)	Grade 4 (%)
Insomnia	73 (13.5%)	1 (0.2%)	0	61 (11.3%)	0	0
Respiratory, Thoracic and Mediastinal Disorders						
Cough	94 (17.3%)	0	0	73 (13.5%)	1 (0.2%)	0
Dyspnea	64 (11.8%)	11 (2.0%)	2 (0.4%)	52 (9.6%)	4 (0.7%)	1 (0.2%)
Renal and Urinary Disorders						
Hematuria	56 (10.3%)	7 (1.3%)	0	30 (5.6%)	3 (0.6%)	0
Vascular Disorders						
Hot flush	121 (22.3%)	1 (0.2%)	0	98 (18.1%)	0	0
Hypertension	117 (21.6%)	21 (3.9%)	0	71 (13.1%)	16 (3.0%)	0
Hematoma	19 (3.5%)	0	0	6 (1.1%)	0	0

^a Cardiac failure also included cardiac failure congestive, ejection fraction decreased, and left ventricular dysfunction.

^b Angina pectoris included due to its clinical relevance.

^c Joint pain or discomfort included: arthralgia, arthritis, bursitis, joint swelling, joint stiffness, joint range of motion decreased, joint effusion, osteoarthritis, spinal osteoarthritis, tendonitis, rheumatoid arthritis

Placebo-controlled Phase 3 Study in mCRPC Patients with Prior Treatment with Docetaxel (Study 301)

In a placebo-controlled, multicentre Phase 3 clinical study of patients with mCRPC who were using a gonadotropin releasing hormone (GnRH) agonist or were previously treated with orchiectomy, and previously treated with docetaxel, ZYTIGA[®] was administered at a dose of 1 g daily in combination with low dose prednisone (10 mg daily) in the active treatment arm; placebo plus low dose prednisone (10 mg daily) was given to control patients. Patients enrolled were intolerant to or had failed up to two prior chemotherapy regimens, one of which contained docetaxel. The average duration of treatment with ZYTIGA[®] was 32 weeks and the duration of treatment for placebo was 16 weeks.

The most common all grade adverse reactions observed with ZYTIGA[®] compared to placebo were myopathy (36.3% vs. 30.9%), joint pain or discomfort (30.7% vs. 24.1%), peripheral edema (24.9% vs. 17.3%), hot flush (19.0% vs. 16.8%), diarrhea (17.6% vs. 13.5%), hypokalemia (17.1% vs. 8.4%), urinary tract infection (11.5% vs. 7.1%), and cough 10.6% vs. 7.6%).

The most common serious adverse reactions observed with ZYTIGA[®] compared to placebo were urinary tract infection (1.8% vs. 0.8%), bone fracture (1.6% vs. 0.6%), and hypokalemia (0.8% vs. 0%).

The most common adverse reactions leading to clinical intervention with ZYTIGA[®] compared to placebo were AST elevation (1.4% vs. 0.5%), ALT elevation (1.1% vs. 0%), hypokalemia (1.1% vs. 0.5%), urinary tract infection (0.9% vs. 0.3%), hypertension (0.9% vs. 0.3%), congestive heart failure (0.5% vs. 0%), and angina pectoris (0.3% vs. 0%).

Anticipated mineralocorticoid effects were seen more commonly in patients treated with ZYTIGA[®] versus patients treated with placebo: hypokalemia (17% vs. 8%), hypertension (9% vs. 7%) and fluid retention (peripheral edema) (25% vs. 17%), respectively. In patients treated with ZYTIGA[®], Grades

3 and 4 hypokalemia and Grades 3 and 4 hypertension were observed in 4% and 1% of patients, respectively.

Table 2: Adverse Drug Reactions that Occurred in a Phase 3 Study with mCRPC Patients with Prior Treatment with Docetaxel (Study 301) in $\geq 2\%$ (all Grades) of Patients in the ZYTIGA® Group

	ZYTIGA® 1 g with Prednisone 10 mg Daily N=791			Placebo with Prednisone 10 mg Daily N=394		
System Organ Class / MedDRA Preferred Term (PT)	All Grades (%)	Grade 3 (%)	Grade 4 (%)	All Grades (%)	Grade 3 (%)	Grade 4 (%)
Cardiac Disorders						
Arrhythmia ^a	56 (7.0%)	7 (0.9%)	2 (0.2%)	15 (4.0%)	2 (0.5%)	1 (0.3%)
Cardiac failure ^b	16 (2.0%)	12 (1.5%)	1 (0.1%)	4 (1.0%)	0	1 (0.3%)
Angina pectoris ^c	10 (1.3%)	2 (0.3%)	0	2 (0.5%)	0	0
General Disorders and Administrative Site Conditions						
Edema peripheral	197 (24.9%)	11 (1.4%)	1 (0.1%)	68 (17.3%)	3 (0.8%)	0
Gastrointestinal Disorders						
Diarrhea	139 (17.6%)	5 (0.6%)	0	53 (13.5%)	5 (1.3%)	0
Dyspepsia	48 (6.1%)	0	0	13 (3.3%)	0	0
Injury, Poisoning and Procedural Complications						
Fractures ^d	47 (5.9%)	8 (1.0%)	3 (0.4%)	9 (2.3%)	0	0
Infections and Infestations						
Urinary tract infection	91 (11.5%)	17 (2.1%)	0	28 (7.1%)	2 (0.5%)	0
Upper respiratory tract infection	43 (5.4%)	0	0	10 (2.5%)	0	0
Musculoskeletal and Connective Tissue Disorders						
Joint pain or discomfort ^e	243 (30.7%)	37 (4.7%)	0	95 (24.1%)	17 (4.3%)	0
Myopathy ^f	287 (36.3%)	43 (5.4%)	2 (0.2%)	122 (30.9%)	14 (4.6%)	1 (0.3%)
Metabolism and Nutrition Disorders						
Hypokalemia	135 (17.1%)	27 (3.4%)	3 (0.4%)	33 (8.4%)	3 (0.8%)	0
Respiratory, Thoracic and Mediastinal Disorders						
Cough	84 (10.6%)	0	0	30 (7.6%)	0	0
Renal and Urinary Disorders						
Urinary frequency	57 (7.2%)	2 (0.3%)	0	20 (5.1%)	1 (0.3%)	0
Nocturia	49 (6.2%)	0	0	16 (4.1%)	0	0
Vascular Disorders						
Hot flush	150 (19.0%)	2 (0.3%)	0	66 (16.8%)	1 (0.3%)	0
Hypertension	67 (8.5%)	10 (1.3%)	0	27 (6.9%)	1 (0.3%)	0

	ZYTIGA [®] 1 g with Prednisone 10 mg Daily N=791			Placebo with Prednisone 10 mg Daily N=394		
System Organ Class / MedDRA Preferred Term (PT)	All Grades (%)	Grade 3 (%)	Grade 4 (%)	All Grades (%)	Grade 3 (%)	Grade 4 (%)

^a Arrhythmia included: tachycardia, atrial fibrillation, arrhythmia, bradycardia, supraventricular tachycardia, atrial tachycardia, atrioventricular block complete, conduction disorder, ventricular tachycardia, atrial flutter, bradyarrhythmia.

^b Cardiac failure also included cardiac failure congestive, ejection fraction decreased, and left ventricular dysfunction.

^c Angina pectoris included due to its clinical relevance.

^d Fractures included all fractures with the exception of pathological fracture.

^e Joint pain or discomfort included: arthralgia, arthritis, arthropathy, bursitis, joint swelling, joint stiffness, joint range of motion decreased, joint effusion, joint ankylosis, osteoarthritis, rheumatoid arthritis, spinal osteoarthritis, spondylolisthesis, tendonitis.

^f Myopathy included: musculoskeletal pain, musculoskeletal stiffness, musculoskeletal chest pain, myalgia, muscular weakness, musculoskeletal discomfort, myopathy, limb discomfort, blood creatine phosphokinase increased, muscle atrophy, muscle fatigue, muscle twitching, myopathy steroid.

Placebo-controlled Phase 3 Study in Patients with Newly Diagnosed High-Risk Metastatic Prostate Cancer (Study 3011 – LATITUDE)

In a Phase 3 study of patients with newly diagnosed high-risk metastatic hormone-sensitive prostate cancer who may have received up to 3 months of prior ADT, ZYTIGA[®] was administered at a dose of 1 g daily in combination with low-dose prednisone (5 mg daily) and ADT (a GnRH agonist or orchiectomy) in the active treatment arm; ADT and placebo were given to control patients. The median duration of treatment was 26 months with ZYTIGA[®] and 14 months with placebo. For patients who had crossed over from the placebo arm to ZYTIGA[®], the median total treatment duration on ZYTIGA was 12 months.

The results from the final analysis of safety were consistent with those presented in the first interim analysis. With an additional 22 months of data collection since the time of the first interim analysis, there were no clinically relevant changes in the safety profile of ZYTIGA[®] profile.

The most common all grade adverse reactions observed with ZYTIGA[®] compared to placebo were hypertension (38.4% versus 22.1%), hypokalemia (24.0% versus 3.8%), and hot flushes (15.4% versus 12.6%).

The most common serious adverse reactions observed with ZYTIGA[®] compared to placebo were pneumonia (2.0% versus 0.3%), urinary tract infection (1.3% versus 0.8%), and hematuria (1.3% versus 0.5%).

The most common adverse reactions leading to clinical intervention with ZYTIGA[®] compared to placebo were hypokalemia (9.5% versus 0.8%), hypertension (7.2% versus 2.7%), AST increased (5.7% versus 1.7%), and ALT increased (5.5% versus 1.8%).

Anticipated mineralocorticoid effects were seen more commonly in study 3011 in patients treated with ZYTIGA[®] versus patients treated with placebo: hypertension (40.7% versus 23.9%), hypokalemia (24.0% versus 3.8%) and fluid retention/edema (13.6% versus 11.8%). In patients treated with ZYTIGA[®], Grade 3 and 4 hypokalemia was reported in 10.9% and 0.8% patients respectively. Grade 3 and 4 hypertension was 21.8% and 0.2% respectively.

Table 3: Adverse Drug Reactions that Occurred in the Phase 3 Study of Newly Diagnosed High-Risk Metastatic Hormone-sensitive Prostate Cancer Patients (Study 3011) with $\geq 2\%$ increase in frequency (all Grades) in the ZYTIGA[®] Group compared to Placebo.

System Organ Class / MedDRA Preferred Term (PT)	ZYTIGA [®] 1 g with Prednisone 5 mg and ADT ^a Daily N=597 ^b			Placebo and ADT ^a Daily N=602 ^b		
	All Grades (%)	Grade 3 (%)	Grade 4 (%)	All Grades (%)	Grade 3 (%)	Grade 4 (%)
Cardiac Disorders						
Cardiac Failure	9 (1.5%)	2 (0.3%)	1 (0.2%)	2 (0.3%)	0	0
Angina pectoris	10 (1.7%)	3 (0.5%)	1 (0.2%)	5 (0.8%)	0	0
Atrial fibrillation	10 (1.7%)	2 (0.3%)	0	2 (0.3%)	1 (0.2%)	0
Infections and Infestations						
Urinary tract infection	44 (7.4%)	6 (1%)	0	23 (3.8%)	5 (0.8%)	0
Upper respiratory tract infection	42 (7.0%)	1 (0.2%)	0	29 (4.8%)	1 (0.2%)	0
Influenza	42 (7.0%)	0	0	20 (3.3%)	0	0
Bronchitis	24 (4.0%)	2 (0.3%)	0	8 (1.3%)	0	0
Injury, Poisoning and Procedural Complications						
Rib fracture	15 (2.5%)	0	0	2 (0.3%)	0	0
Metabolism and Nutrition Disorders						
Hypokalemia [†]	143 (24.0%)	65 (10.9%)	5 (0.8%)	23 (3.8%)	9 (1.5%)	1 (0.2%)
Nervous System Disorders						
Headache	46 (7.7%)	2 (0.3%)	0	31 (5.1%)	1 (0.2%)	0
Psychiatric Disorders						
Depression	17 (2.8%)	0	0	5 (0.8%)	0	0
Respiratory, Thoracic and Mediastinal Disorders						
Cough	41 (6.9%)	0	0	18 (3.0%)	0	0
Vascular Disorders						
Hypertension	229 (38.4%)	125 (20.9%)	0	133 (22.1%)	59 (9.8%)	1(0.2%)
Hot flush	92 (15.4%)	0	0	76 (12.6%)	1 (0.2%)	0

^a All patients were receiving a GnRH agonist or had undergone orchiectomy.

^b n=patients assessed for safety.

[†]investigator assessed AE based on reported symptoms

Cardiovascular Effects: The Phase 3 studies excluded patients with uncontrolled hypertension, clinically significant heart disease as evidenced by myocardial infarction, arterial thrombotic events in the past 6 months, severe or unstable angina, or LVEF <50% or New York Heart Association (NYHA) Class III or IV heart disease (Study 301), or NYHA Class II to IV heart disease (Studies 302 and 3011). All patients enrolled (both active and placebo-treated patients) were concomitantly treated with androgen deprivation therapy (ADT), predominantly with the use of GnRH agonists, which has been associated with diabetes, myocardial infarction, cerebrovascular accident and sudden cardiac death.

In combined data from Phase 3 trials, the incidence of cardiovascular adverse reactions in patients taking ZYTIGA[®] versus patients taking placebo were as follows: atrial fibrillation, 2.6% vs. 2.0%; tachycardia, 1.9% vs. 1.0%; angina pectoris, 1.7% vs. 0.8%; cardiac failure, 0.7% vs. 0.2%; and arrhythmia, 0.7% vs. 0.5%.

Hepatotoxicity: Drug-associated hepatotoxicity with elevated serum transaminases (ALT and AST) and total bilirubin has been reported in patients treated with ZYTIGA[®]. Across Phase 3 clinical studies, hepatotoxicity Grades 3 and 4 (e.g., ALT or AST increases of >5X ULN or bilirubin increases >1.5X ULN) were reported in approximately 6% of patients who received ZYTIGA[®], typically during the first 3 months after starting treatment.

In the Phase 3 clinical study in mCRPC patients with prior treatment with docetaxel (Study 301), patients whose baseline ALT or AST were elevated were more likely to experience liver function test elevations than those beginning with normal values. When elevations of either ALT or AST >5X ULN, or elevations in bilirubin >3X ULN were observed, ZYTIGA[®] was withheld or discontinued. In two instances marked increases in liver function tests occurred (see **WARNINGS AND PRECAUTIONS**). These two patients with normal baseline hepatic function experienced ALT or AST elevations 15X to 40X ULN and bilirubin elevations 2X to 6X ULN. Upon interruption of ZYTIGA[®], both patients had normalization of their liver function tests. One patient was re-treated with ZYTIGA[®]. Recurrence of the elevations was not observed in this patient.

In the Phase 3 clinical study of asymptomatic or mildly symptomatic mCRPC patients (Study 302), Grade 3 or 4 ALT or AST elevations were observed in 35 (6.5%) patients treated with ZYTIGA[®]. Aminotransferase elevations resolved in all but three patients (two with new multiple liver metastases, and one with AST elevation approximately three weeks after the last dose of ZYTIGA[®]).

In the Phase 3 clinical study of newly diagnosed high-risk metastatic prostate cancer (Study 3011), Grade 3 and Grade 4 hepatotoxicity was observed in 8.2% and 0.7% of patients treated with ZYTIGA[®]. Ten patients (1.7%) who received ZYTIGA[®] were discontinued because of hepatotoxicity; two had Grade 2 hepatotoxicity, six had Grade 3 hepatotoxicity, and two had Grade 4 hepatotoxicity. No patient died of hepatotoxicity in Study 3011.

In Phase 3 clinical studies, treatment discontinuations due to ALT and AST increases or abnormal hepatic function were reported in 1.1% of patients treated with ZYTIGA[®] and 0.6% of patients treated with placebo, respectively; no deaths were reported due to hepatotoxicity events.

In clinical trials, the risk for hepatotoxicity was mitigated by exclusion of patients with active hepatitis or baseline hepatitis or significant abnormalities of liver function tests. In the trial with mCRPC patients who had received prior treatment with docetaxel (Study 301), patients with baseline ALT and AST $\geq 2.5X$ ULN in the absence of liver metastases and >5X ULN in the presence of liver metastases were excluded. In the trial with asymptomatic or mildly symptomatic mCRPC patients (Study 302), those with liver metastases were not eligible and patients with baseline ALT and AST $\geq 2.5X$ ULN were excluded. In the trial of newly diagnosed high-risk metastatic hormone-sensitive prostate cancer (Study 3011), patients with baseline ALT and AST >2.5X ULN, bilirubin >1.5X ULN or those with active or symptomatic viral hepatitis or chronic liver disease, ascites or bleeding disorders secondary to hepatic dysfunction were excluded. Abnormal liver function tests developing in patients participating in clinical trials were managed by treatment interruption and by permitting re-treatment only after return of liver function tests to the patient's baseline (see **DOSAGE AND ADMINISTRATION**). Patients with elevations of ALT or AST >20X ULN were not re-treated. The safety of re-treatment in such patients is unknown.

Less Common Clinical Trial Adverse Drug Reactions (< 2%)

General Disorders and Administrative Site Conditions: Influenza-like illness

Investigations: Blood creatinine increased, weight increased

Infections and Infestations: Lower respiratory tract infection

Metabolism and Nutrition Disorders: Hypertriglyceridemia

Endocrine Disorders: Adrenal insufficiency

Abnormal Hematologic and Clinical Chemistry Findings:

Table 4, Table 5 and Table 6 show laboratory values of interest from the placebo-controlled Phase 3 trials.

Table 4: Selected Laboratory Abnormalities in mCRPC Asymptomatic or Mildly Symptomatic Patients who Received ZYTIGA® (Study 302)

	ZYTIGA® 1 g with Prednisone 10 mg Daily N=542		Placebo with Prednisone 10 mg Daily N=540	
	All Grades %	Grade 3/4 %	All Grades %	Grade 3/4 %
ALT increased	41	6	28	1
AST increased	36	3	27	1
Bilirubin increased	11	<1	4	<1
Hypokalemia	14	2	8	1
Hypophosphatemia	26	5	14	2
Hypertriglyceridemia	22	0	17	0
Hypernatremia	30	<1	24	<1
Hypercalcemia	10	0	4	0
Lymphopenia	36	7	30	0

Table 5: Selected Laboratory Abnormalities in mCRPC Patients with Prior Treatment with Docetaxel who Received ZYTIGA® (Study 301)

	ZYTIGA® 1 g with Prednisone 10 mg Daily N=791		Placebo with Prednisone 10 mg Daily N=394	
	All Grades %	Grade 3/4 %	All Grades %	Grade 3/4 %
ALT increased	11	1	10	<1
AST increased	30	2	34	1
Bilirubin increased	6	<1	3	0
Hypokalemia	19	3	10	<1
Hypercholesterolemia	55	<1	48	<1
Low phosphorus	23	7	15	5
Hypertriglyceridemia	62	<1	53	0

Table 6: Selected Laboratory Abnormalities in Patients with Newly Diagnosed High-Risk Metastatic Hormone-sensitive Prostate Cancer who Received ZYTIGA® (Study 3011)

	ZYTIGA® 1 g with Prednisone 5 mg Daily N=597		Placebo N=602	
	All Grades %	Grade 3/4 %	All Grades %	Grade 3/4 %
ALT increased	45	6	45	1
AST increased	46	5	46	2
Bilirubin increased	16	<1	6	<1
Hypokalemia	30	10	7	1
Lymphopenia	20	5	13	2

Post-Market Adverse Drug Reactions

The following adverse reactions have been identified during post approval use of ZYTIGA®. Because these reactions are reported voluntarily from a population of uncertain size, it is not always possible to reliably estimate their frequency or establish a causal relationship to drug exposure.

Respiratory, thoracic and mediastinal disorders: allergic alveolitis

Musculoskeletal and connective tissue disorders: rhabdomyolysis, myopathy

Hepatobiliary disorders: hepatitis fulminant, acute hepatic failure with fatalities (see **Serious WARNINGS AND PRECAUTIONS Box**, and **WARNINGS AND PRECAUTIONS, Hepatic**)

Cardiac disorders: QT prolongation and Torsades de Pointes (observed in patients who developed hypokalemia or had underlying cardiovascular conditions, see **WARNINGS AND PRECAUTIONS, Cardiovascular**).

DRUG INTERACTIONS

Overview

In vitro studies indicated that CYP3A4 and SULT2A1 are the major isoenzymes involved in the metabolism of abiraterone (see **DETAILED PHARMACOLOGY, Non-clinical Pharmacokinetics**). Abiraterone is an inhibitor of the hepatic drug-metabolizing enzymes CYP2C8 and CYP2D6 (see **Drug-Drug Interactions**).

Drug-Drug Interactions

Potential for other medicinal ingredients to affect ZYTIGA®

CYP3A4 inducers: Based on *in vitro* data, the active metabolite abiraterone is a substrate of CYP3A4. In a clinical pharmacokinetic interaction study of healthy subjects pretreated with a strong CYP3A4 inducer (rifampicin, 600 mg daily for 6 days) followed by a single dose of abiraterone acetate 1000 mg, the mean plasma AUC_∞ of abiraterone was decreased by 55%. Strong inducers of CYP3A4 (e.g., phenytoin, carbamazepine, rifampicin, rifabutin, phenobarbital) during treatment with ZYTIGA® are to be avoided. If patients must be co-administered a strong CYP3A4 inducer, careful evaluation of clinical efficacy must be undertaken as there are no clinical data recommending an appropriate dose adjustment.

CYP3A4 inhibitors: In a clinical pharmacokinetic interaction study, healthy subjects were administered ketoconazole, a strong CYP3A4 inhibitor, 400 mg daily for 6 days. No clinically

meaningful effect on the pharmacokinetics of abiraterone was demonstrated following co-administration of a single dose of abiraterone acetate, 1000 mg at day 4.

Potential for ZYTIGA[®] to affect other drugs

CYP1A2: In a clinical study to determine the effects of abiraterone acetate (plus prednisone) on a single dose of the CYP1A2 substrate theophylline, no increase in systemic exposure of theophylline was observed.

CYP2D6: In the same study to determine the effects of abiraterone acetate (plus prednisone) on a single dose of the CYP2D6 substrate dextromethorphan, the systemic exposure (AUC) of dextromethorphan was increased by approximately 200%. The AUC₂₄ for dextromethorphan, the active metabolite of dextromethorphan, increased by approximately 33%.

ZYTIGA[®] is an inhibitor of the hepatic drug-metabolizing enzyme CYP2D6. Caution is advised when ZYTIGA[®] is administered with drugs activated by or metabolized by CYP2D6, particularly with drugs that have a narrow therapeutic index. Dose reduction of narrow therapeutic index drugs metabolized by CYP2D6 should be considered.

CYP2C8: In a CYP2C8 drug-drug interaction trial in healthy subjects, the AUC of pioglitazone was increased by 46% and the AUCs for M-III and M-IV, the active metabolites of the CYP2C8 substrate pioglitazone, each decreased by 10%, when a single dose of pioglitazone was given together with a single dose of 1000 mg abiraterone acetate. Although ZYTIGA[®] is an inhibitor of CYP2C8, these results indicate that no clinically meaningful increases in exposure are expected when ZYTIGA[®] is combined with drugs that are predominantly eliminated by CYP2C8. Patients should be monitored for signs of toxicity related to a CYP2C8 substrate with a narrow therapeutic index if used concomitantly with ZYTIGA[®].

CYP2C9, CYP2C19 and CYP3A4/5: *In vitro* studies with human hepatic microsomes demonstrated that abiraterone was a moderate inhibitor of CYP2C9, CYP2C19 and CYP3A4/5. No clinical DDI studies have been performed to confirm these *in vitro* findings (see **DETAILED PHARMACOLOGY, Non-clinical Pharmacokinetics**).

OATP1B1: *In vitro*, abiraterone and its major metabolites were shown to inhibit the hepatic uptake transporter OATP1B1 and as a consequence it may increase the concentrations of drugs that are eliminated by OATP1B1. There are no clinical data available to confirm transporter-based interaction.

Drug-Food Interactions

Administration of ZYTIGA[®] with food significantly increases the absorption of abiraterone acetate. The efficacy and safety of ZYTIGA[®] given with food has not been established. **ZYTIGA[®] must not be taken with solid or liquid food (see DOSAGE AND ADMINISTRATION and ACTION AND CLINICAL PHARMACOLOGY, Pharmacokinetics)**.

Drug-Herb Interactions

Co-administration of ZYTIGA[®] with St. John's wort (*Hypericum perforatum*) may potentially reduce the plasma concentrations of ZYTIGA[®]. Concomitant use with St. John's wort or products containing St. John's wort is to be avoided.

Drug-Lifestyle Interactions

No studies on the effects of ZYTIGA[®] on the ability to drive or use machines have been performed. It is not anticipated that ZYTIGA[®] will affect the ability to drive and use machines.

DOSAGE AND ADMINISTRATION

Recommended Dose

The recommended dosage of ZYTIGA[®] is 1 g (two 500 mg tablets or four 250 mg tablets) as a single daily dose that **must be taken on an empty stomach**. No solid or liquid food should be consumed for at least two hours before the dose of ZYTIGA[®] is taken and for at least one hour after the dose of ZYTIGA[®] is taken. The tablets should be swallowed whole with water.

Recommended Dose of Prednisone

For metastatic castration-resistant prostate cancer (mCRPC), ZYTIGA[®] is used with 10 mg prednisone daily. For newly diagnosed high-risk metastatic prostate cancer, ZYTIGA[®] is used with 5 mg prednisone daily.

Administration

Patients started on ZYTIGA[®] who were receiving a GnRH agonist should continue to receive a GnRH agonist.

Serum transaminases and bilirubin should be measured prior to starting treatment with ZYTIGA[®], every two weeks for the first three months of treatment and monthly thereafter.

Blood pressure, serum potassium and fluid retention should be monitored monthly (see **WARNINGS AND PRECAUTIONS, Cardiovascular, *Hypertension, Hypokalemia and Fluid Retention Due to Mineralocorticoid Excess***).

Missed Dose

In the event of a missed daily dose of either ZYTIGA[®] or prednisone, treatment should be resumed the following day with the usual daily dose.

Dose Adjustment in Patients with Hepatic Impairment

ZYTIGA[®] should not be used in patients with pre-existing moderate or severe hepatic impairment (see **ACTION AND CLINICAL PHARMACOLOGY**).

No dosage adjustment is necessary for patients with pre-existing mild hepatic impairment.

For patients who develop hepatotoxicity during treatment with ZYTIGA[®] (serum transaminases, ALT or AST rise above 5 times the upper limit of normal or bilirubin rises above 3 times the upper limit of normal) treatment should be withheld immediately until liver function tests normalize (see **WARNINGS AND PRECAUTIONS, Hepatic**).

Re-treatment following return of liver function tests to the patient's baseline may be given at a reduced dose of 500 mg (one 500 mg tablet or two 250 mg tablets) once daily. For patients being re-treated, serum transaminases and bilirubin should be monitored at a minimum of every two weeks for three months and monthly thereafter. If hepatotoxicity recurs at the reduced dose of 500 mg

daily, discontinue treatment with ZYTIGA[®]. Reduced doses should not be taken with food (see **DOSAGE AND ADMINISTRATION, Recommended Dose and Dosage Adjustment**).

If patients develop severe hepatotoxicity (ALT 20 times the upper limit of normal) anytime while on therapy, ZYTIGA[®] should be discontinued and patients should not be re-treated with ZYTIGA[®].

Permanently discontinue ZYTIGA[®] for patients who develop a concurrent elevation of ALT greater than 3 times the upper limit of normal **and** total bilirubin greater than 2 times the upper limit of normal in the absence of biliary obstruction or other causes responsible for the concurrent elevation.

Dose Adjustment in Patients with Renal Impairment

No dosage adjustment is necessary for patients with renal impairment.

OVERDOSAGE

Human experience of overdose with ZYTIGA[®] is limited.

There is no specific antidote. In the event of an overdose, administration of ZYTIGA[®] should be stopped and general supportive measures undertaken, including monitoring for arrhythmias. Liver function also should be assessed.

For management of a suspected drug overdose, contact your regional Poison Control Centre.

ACTION AND CLINICAL PHARMACOLOGY

Mechanism of Action

Abiraterone acetate (ZYTIGA[®]) is converted *in vivo* to abiraterone, an androgen biosynthesis inhibitor. Specifically, abiraterone selectively inhibits the enzyme 17 α -hydroxylase/C17,20-lyase (CYP17). This enzyme is expressed in and is required for androgen biosynthesis in testicular, adrenal and prostatic tumor tissues. It catalyzes the conversion of pregnenolone and progesterone into testosterone precursors, DHEA and androstenedione, respectively, by 17- α hydroxylation and cleavage of the C17,20 bond. CYP17 inhibition also results in increased mineralocorticoid production by the adrenals (see **WARNINGS AND PRECAUTIONS, *Hypertension, Hypokalemia and Fluid Retention Due to Mineralocorticoid Excess***).

Androgen-sensitive prostatic carcinoma responds to treatment that decreases androgen levels. Androgen deprivation therapies, such as treatment with GnRH agonists or orchiectomy, decrease androgen production in the testes but do not affect androgen production by the adrenals or in the tumor. ZYTIGA[®] decreases serum testosterone and other androgens in patients to levels lower than those achieved by the use of GnRH agonists alone or by orchiectomy. Commercial testosterone assays have inadequate sensitivity to detect the effect of ZYTIGA[®] on serum testosterone levels, therefore, it is not necessary to monitor the effect of ZYTIGA[®] on serum testosterone levels.

Changes in serum prostate specific antigen (PSA) levels may be observed but have not been shown to correlate with clinical benefit in individual patients.

Pharmacodynamics

Cardiac Electrophysiology: A multicentre, open-label, uncontrolled, single arm ECG assessment study was performed in 33 patients with metastatic castration-resistant prostate cancer who were medically (N=28) or surgically castrated (N=5). Patients had serial ECG recordings at baseline and on day 1 of the first and second 28-day cycles of treatment with abiraterone acetate 1g/day plus prednisone 5 mg twice daily. At steady-state on day 1 of cycle 2, the QTc interval was significantly shortened at most time points, with a maximum decrease from baseline of mean -10.7 (90% CI -14.8, -6.5) ms at 24 h post-dosing.

Androgen deprivation is associated with QTc prolongation. In this study the QTc interval averaged 435–440 ms at baseline and 57.6% of subjects had baseline QTc values > 450 ms prior to initiation of abiraterone acetate. Because the subjects in this trial were already androgen-deprived, the results of this study cannot be extrapolated to non-castrated populations.

Mineralocorticoid receptor antagonists: Patients in the pivotal clinical trials (COU-AA-302 and COU-AA-301) were not allowed to use the mineralocorticoid receptor antagonist spironolactone with ZYTIGA[®] since spironolactone has the ability to bind and activate the wild type androgen receptor, which could stimulate disease progression. The use of spironolactone with ZYTIGA[®] should be avoided.

Prior use of ketoconazole: Based on experience in an early abiraterone acetate trial, lower rates of response might be expected in patients previously treated with ketoconazole for prostate cancer.

Pharmacokinetics

Following administration of abiraterone acetate, the pharmacokinetics of abiraterone and abiraterone acetate have been studied in healthy subjects, patients with metastatic prostate cancer and subjects without cancer with hepatic or renal impairment. Abiraterone acetate is rapidly converted *in vivo* to abiraterone, an androgen biosynthesis inhibitor. In clinical studies, abiraterone acetate plasma concentrations were below detectable levels (< 0.2 ng/mL) in > 99% of the analyzed samples.

Absorption: The AUC and C_{max} values in patients with castration-resistant prostate cancer were 979 ng•h/mL and 216.5 ng/mL respectively. In addition, there was large inter-patient variability observed for healthy subjects and patients with castration-resistant prostate cancer.

There was an observed reduction in the clearance of patients with castration-resistant prostate cancer (33%) compared to healthy subjects. This reduction could translate to a 40% mean increase of mean population predicted exposure in patients relative to healthy subjects, but this increase may be confounded with effects of concomitant medications and food intake conditions. This difference is not considered to be clinically relevant.

Following oral administration of abiraterone acetate in the fasting state, the time to reach maximum plasma abiraterone concentration is approximately 2 hours in patients with castration-resistant prostate cancer.

Systemic exposure of abiraterone is increased when abiraterone acetate is administered with food. Abiraterone C_{max} and AUC were approximately 7- and 5-fold higher, respectively, when abiraterone acetate was administered with a low-fat meal (7% fat, 300 calories) and approximately 17- and 10-

fold higher, respectively when abiraterone acetate was administered with a high-fat meal (57% fat, 825 calories).

Given the normal variation in the content and composition of meals, taking ZYTIGA[®] with meals has the potential to result in highly variable exposures. Therefore, ZYTIGA[®] **must be taken on an empty stomach**. No solid or liquid food should be consumed at least two hours before taking ZYTIGA[®] and for at least one hour after taking ZYTIGA[®]. The tablets should be swallowed whole with water (see **DOSAGE AND ADMINISTRATION**).

Distribution: The plasma protein binding of ¹⁴C-abiraterone in human plasma is 99.8%. The apparent volume of distribution is approximately 5630 L, suggesting that abiraterone extensively distributes to peripheral tissues. *In vitro* studies show that at clinically relevant concentrations, abiraterone acetate and abiraterone are not substrates of P-glycoprotein (P-gp). *In vitro* studies show that abiraterone acetate is an inhibitor of P-gp. No studies have been conducted with other transporter proteins.

Metabolism: Following oral administration of ¹⁴C-abiraterone acetate as capsules, abiraterone acetate is rapidly hydrolyzed to the active metabolite abiraterone. This reaction is not CYP mediated but hypothesized to occur via an unidentified esterase(s). Abiraterone then undergoes metabolism including sulphation, hydroxylation and oxidation primarily in the liver. This results in the formation of two main plasma circulating inactive metabolites, abiraterone sulphate and N-oxide abiraterone sulphate, each accounting for approximately 43% of total radioactivity. The formation of N-oxide abiraterone sulphate is predominantly catalyzed by CYP3A4 and SULT2A1 while the formation of abiraterone sulphate is catalyzed by SULT2A1.

Excretion: The mean half-life of abiraterone in plasma is approximately 15 hours based on data from healthy subjects and approximately 12 hours based on data from patients with metastatic castration-resistant prostate cancer. Following oral administration of ¹⁴C-abiraterone acetate, approximately 88% of the radioactive dose is recovered in feces and approximately 5% in urine. The major compounds present in feces are unchanged abiraterone acetate and abiraterone (approximately 55% and 22% of the administered dose, respectively).

Special Populations and Conditions

The effect of intrinsic factors such as age and body weight has been evaluated using population pharmacokinetic approaches and no statistically significant effect was evident for any of these covariates.

Pediatrics: Abiraterone acetate has not been investigated in pediatric subjects.

Gender: All clinical study information thus far is derived from male subjects.

Hepatic Insufficiency: The pharmacokinetics of abiraterone was examined in non-mCRPC subjects with pre-existing mild (N=8) or moderate (N=8) hepatic impairment (Child-Pugh class A and B, respectively) and in healthy control subjects (N=8). Systemic exposure (AUC) to abiraterone after a single oral 1 g dose increased by approximately 1.1-fold and 3.6-fold in subjects with mild and moderate pre-existing hepatic impairment, respectively. The mean half-life of abiraterone was prolonged from approximately 13 hours in healthy subjects to approximately 18 hours in subjects with mild hepatic impairment and to approximately 19 hours in subjects with moderate hepatic

impairment. No dosage adjustment is necessary for mCRPC patients with pre-existing mild hepatic impairment. ZYTIGA[®] should not be used in patients with pre-existing moderate or severe hepatic impairment. The safety of ZYTIGA[®] has not been studied in mCRPC patients with moderate or severe (Child-Pugh Class B or C) hepatic impairment at baseline.

For patients who develop hepatotoxicity during treatment with ZYTIGA[®] suspension of treatment and dosage adjustment may be required (see **DOSAGE AND ADMINISTRATION** and **WARNINGS AND PRECAUTIONS**).

Renal Insufficiency: The pharmacokinetics of abiraterone following the administration of a single oral 1 g dose of abiraterone acetate was compared in patients with end-stage renal disease on a stable hemodialysis schedule (N=8), versus matched control subjects with normal renal function (N=8). Systemic exposure to abiraterone after a single oral 1 g dose did not increase in patients with end-stage renal disease on dialysis.

Administration of ZYTIGA[®] in patients with renal impairment including severe renal impairment does not require dose adjustment (see **DOSAGE AND ADMINISTRATION**).

Genetic Polymorphism: The effect of genetic differences on the pharmacokinetics of abiraterone has not been evaluated.

STORAGE AND STABILITY

Store at 15–30°C.

SPECIAL HANDLING INSTRUCTIONS

Based on its mechanism of action, ZYTIGA[®] may harm a developing fetus; therefore, women who are pregnant or women who may be pregnant should not handle ZYTIGA[®] 250 mg uncoated tablets without protection, e.g., gloves (see section **WARNINGS AND PRECAUTIONS, Special Populations**).

Any unused product or waste material should be disposed of in accordance with local requirements.

DOSAGE FORMS, COMPOSITION AND PACKAGING

ZYTIGA[®] 250 mg uncoated tablets are white to off-white, oval tablets debossed with “AA250” on one side. Inactive ingredients in the tablets are colloidal silicon dioxide, croscarmellose sodium, lactose monohydrate, magnesium stearate, microcrystalline cellulose, povidone, and sodium lauryl sulfate.

ZYTIGA[®] 500 mg film-coated tablets are purple, oval tablets debossed with “AA” on one side and “500” on the other. Inactive ingredients in the tablet core are colloidal silicon dioxide, croscarmellose sodium, hypromellose, lactose monohydrate, magnesium stearate, silicified microcrystalline cellulose, and sodium lauryl sulfate. The tablet film coating contains iron oxide black, iron oxide red, macrogol 3350, polyvinyl alcohol, talc, and titanium dioxide.

ZYTIGA[®] 250 mg uncoated tablets and 500 mg film-coated tablets are available in high-density polyethylene bottles fitted with a polypropylene cap. Package sizes are 60 tablets for 500 mg and 120 tablets for 250 mg.

PART II: SCIENTIFIC INFORMATION

PHARMACEUTICAL INFORMATION

Drug Substance

Proper name: abiraterone acetate

Chemical name: (3 β)-17-(3-pyridinyl)androsta-5,16-dien-3-yl acetate

Molecular formula and molecular mass: C₂₆H₃₃NO₂ and 391.55

Structural formula:

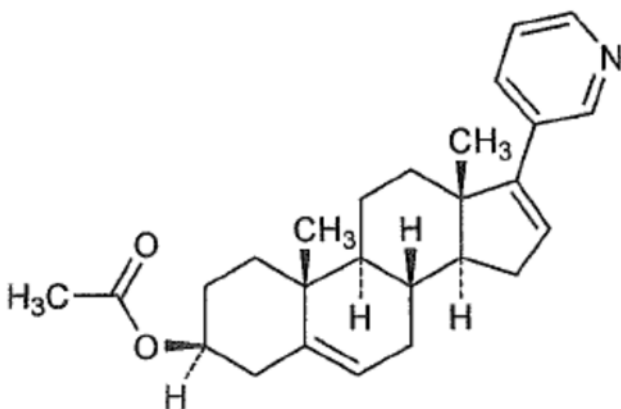

Physicochemical properties: Abiraterone acetate is a white to off-white crystalline powder. Abiraterone acetate is practically insoluble in aqueous media over a wide range of pH values (pH=2.0 to 12.9). The melting point is between 147°C and 148°C. The pKa is 5.19.

CLINICAL TRIALS

The efficacy of ZYTIGA[®] has been established in three randomized, placebo-controlled multicentre Phase 3 clinical studies, including two studies of patients with metastatic prostate cancer (castration-resistant prostate cancer (mCRPC) and one study of patients with newly diagnosed high-risk metastatic prostate cancer.

Placebo-controlled Phase 3 Study in Asymptomatic or Mildly Symptomatic mCRPC Patients (Study 302)

Study design and patient demographics

In this study, the efficacy of ZYTIGA[®] was established in patients with mCRPC (documented by positive bone scans and/or metastatic lesions on CT, MRI other than visceral metastasis) who were asymptomatic (as defined by a score of 0-1 on BPI-SF (Brief Pain Inventory Short Form), worst pain over the last 24 hours) or mildly symptomatic (as defined by a score of 2-3 on BPI-SF, worst pain

over the last 24 hours) after failure of ADT, who were using a GnRH agonist during study treatment or were previously treated with orchiectomy (N=1088). Patients were randomized 1:1 to receive either ZYTIGA[®] or placebo. In the active treatment arm, ZYTIGA[®] was administered orally at a dose of 1 g daily in combination with low dose prednisone 5 mg twice daily (N=546). Control patients received placebo and low dose prednisone 5 mg twice daily (N=542).

Patients were not included in the study if they had moderate or severe pain, opiate use for severe pain, liver or visceral organ metastases, known brain metastasis, clinically significant heart disease, (as evidenced by myocardial infarction, or arterial thrombotic events in the past 6 months, severe or unstable angina, or LVEF <50% or New York Heart Association Class II to IV heart failure), prior ketoconazole for the treatment of prostate cancer, a history of adrenal gland or pituitary disorders or prostate tumor showing extensive small cell (neuroendocrine) histology. Spironolactone was a restricted concomitant therapy due to its potential to stimulate disease progression. Patients who had received prior chemotherapy or biologic therapy were excluded from the study.

The co-primary efficacy endpoints for this study were overall survival (OS) and radiographic progression free survival (rPFS). In addition to the co-primary endpoint measures, benefit was also assessed using time to opiate use for cancer pain, time to initiation of cytotoxic chemotherapy, time to deterioration in ECOG performance score by ≥ 1 point and time to PSA progression based on Prostate Cancer Working Group-2 (PCWG2) criteria. Study treatments were discontinued at the time of unequivocal clinical progression. Unequivocal clinical progression was characterized as cancer pain requiring initiation of chronic administration of opiate analgesia (oral opiate use for ≥ 3 weeks; parenteral opiate use for ≥ 7 days), or immediate need to initiate cytotoxic chemotherapy or the immediate need to have either radiation therapy or surgical intervention for complications due to tumor progression, or deterioration in ECOG performance status to Grade 3 or higher. Treatments could also be discontinued at the time of confirmed radiographic progression at the discretion of the investigator.

Radiographic progression free survival was assessed with the use of sequential imaging studies as defined by Prostate Cancer Working Group-2 (PCWG2) criteria (for bone lesions) with confirmatory bone scans and modified Response Evaluation Criteria In Solid Tumors (RECIST) criteria (for soft tissue lesions). Analysis of rPFS utilized centrally-reviewed radiographic assessment of progression.

Because changes in PSA serum concentration do not always predict clinical benefit, patients were maintained on ZYTIGA[®] until discontinuation criteria were met as specified for the study.

Table 7 summarizes key demographics and baseline disease characteristics. Demographics and baseline disease characteristics were balanced between the two groups.

Table 7: Key Demographics and Baseline Disease Characteristics (Phase 3 Study in Asymptomatic or Mildly Symptomatic mCRPC Patients: ITT Population)

	ZYTIGA® + Prednisone (N=546)	Placebo + Prednisone (N=542)	Total (N=1088)
Age (years)			
N	546	542	1088
Mean (SD)	70.5 (8.80)	70.1 (8.72)	70.3 (8.76)
Median	71.0	70.0	70.0
Range	(44, 95)	(44, 90)	(44, 95)
Sex			
n	546	542	1088
Male	546 (100.0%)	542 (100.0%)	1088 (100.0%)
Race			
n	545	540	1085
White	520 (95.4%)	510 (94.4%)	1030 (94.9%)
Black	15 (2.8%)	13 (2.4%)	28 (2.6%)
Asian	4 (0.7%)	9 (1.7%)	13 (1.2%)
Other	6 (1.1%)	6 (1.1%)	12 (1.1%)
Time From Initial Diagnosis to First Dose (years)			
n	542	540	1082
Mean (SD)	6.7 (4.85)	6.5 (4.77)	6.6 (4.81)
Median	5.5	5.1	5.3
Range	(0, 28)	(0, 28)	(0, 28)
Extent of Disease			
n	544	542	1086
Bone	452 (83.1%)	432 (79.7%)	884 (81.4%)
Bone Only	274 (50.4%)	267 (49.3%)	541 (49.8%)
Soft Tissue or Node	267 (49.1%)	271 (50.0%)	538 (49.5%)
ECOG Performance Status Score			
n	546	542	1088
0	416 (76.2%)	414 (76.4%)	830 (76.3%)
1	130 (23.8%)	128 (23.6%)	258 (23.7%)
Baseline PSA (ng/mL)			
n	546	539	1085
Mean (SD)	133.38 (323.639)	127.63 (387.878)	130.52 (356.846)
Median	42.01	37.74	39.51
Range	(0.0, 3927.4)	(0.7, 6606.4)	(0.0, 6606.4)
Baseline Hemoglobin (g/dL)			
n	545	538	1083
Mean (SD)	12.97 (1.22)	12.99 (1.22)	12.98 (1.22)
Median	13.0	13.1	13.1
Range	(7.2, 16.6)	(7.0, 15.7)	(7.0, 16.6)
Baseline Alkaline Phosphatase (IU/L)			
n	546	539	1085
Mean (SD)	137.4 (166.88)	148.1 (248.11.)	142.8 (211.15)
Median	93.0	90.0	91.0
Range	(32, 1927)	(21, 3056)	(21, 3056)
Baseline Lactate Dehydrogenase (IU/L)			
n	543	536	1079
Mean (SD)	199.9 (78.57)	196.8 (59.20)	198.3 (69.61)
Median	187.0	184.0	185.0
Range	(60, 871)	(87, 781)	(60, 871)

Study results

A median of 15 cycles (60 weeks) were administered in the ZYTIGA[®] group compared with 9 cycles (36 weeks) in the placebo group. The mean duration of treatment with ZYTIGA[®] was 18.8 months and 11.3 months for placebo.

At the planned rPFS analysis there were 401 radiographic progression events; 150 (28%) of patients treated with ZYTIGA[®] and 251 (46%) of patients treated with placebo had radiographic evidence of progression or had died. A significant difference in rPFS between treatment groups was observed, see Table 8 and Figure 1. rPFS analyses by subgroup are presented in Figure 2.

Table 8: rPFS of Patients Treated with Either ZYTIGA[®] or Placebo in Combination with Prednisone Plus GnRH Agonists or Prior Orchiectomy (ITT Population)

	ZYTIGA [®] N=546	Placebo N=542
Progression or death	150 (28%)	251 (46%)
Median rPFS (months) (95% CI)	Not reached (11.66, NE)	8.3 (8.12, 8.54)
Hazard ratio** (95% CI)	0.425 (0.347, 0.522)	
p-value*	<0.0001	

NE=Not Estimated* From a log-rank test of the equality of two survival curves over the time interval, and stratified by baseline ECOG score (0 or 1)

** Hazard Ratio is derived from a stratified proportional hazards model. Hazard ratio <1 favors ZYTIGA[®]

Figure 1: Kaplan Meier Curves of rPFS in Patients Treated with Either ZYTIGA[®] or Placebo in Combination with Prednisone plus GnRH Agonists or Prior Orchiectomy

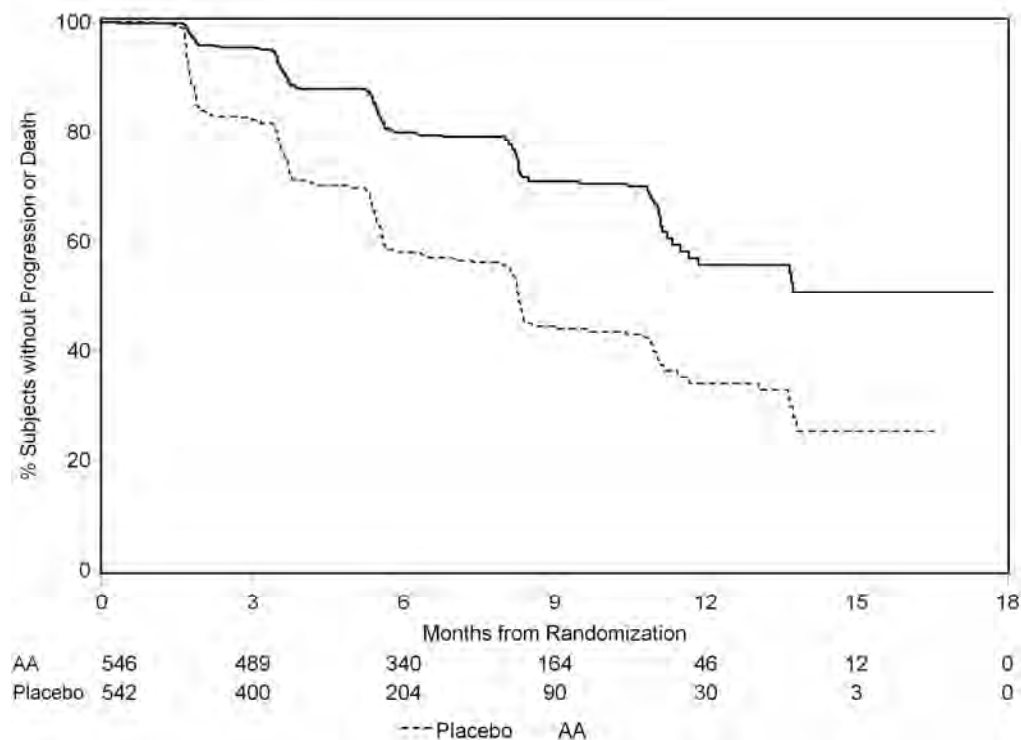
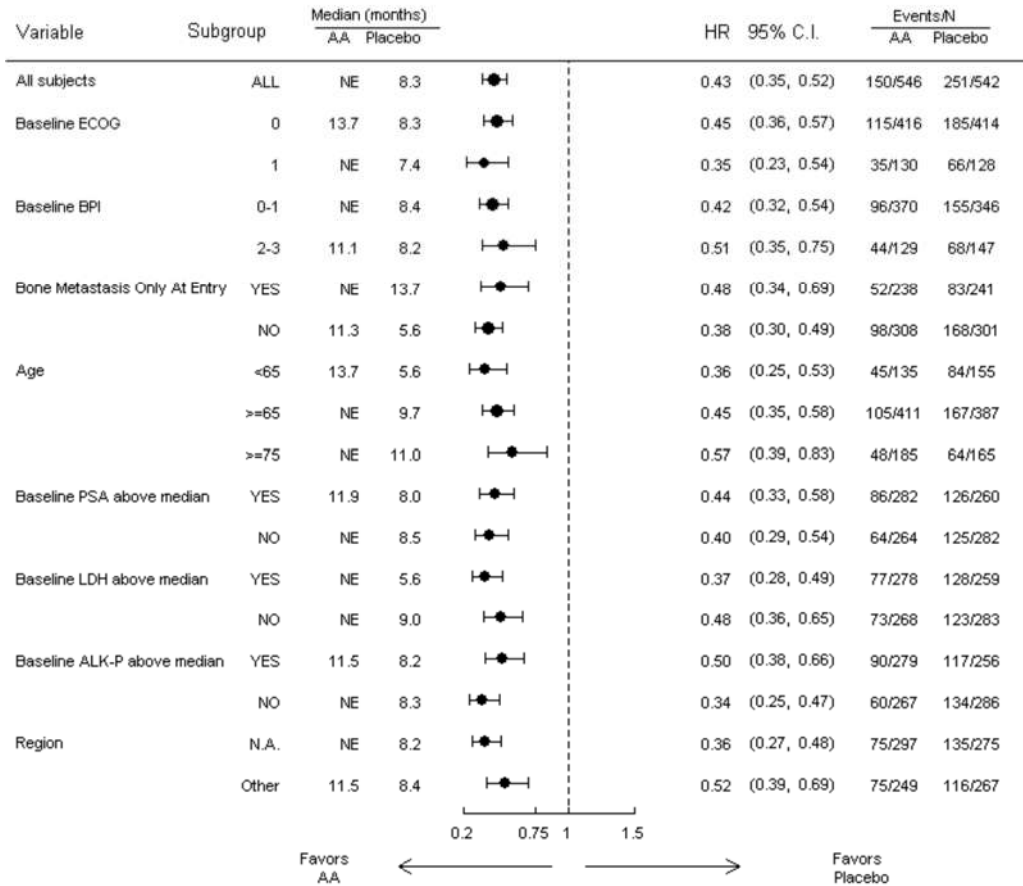

Figure 2: rPFS by Subgroup (ITT Population)



The HR within each subgroup was estimated using a nonstratified Cox proportional hazard model. AA=abiraterone acetate; ALP=alkaline phosphatase; BPI=Brief Pain Inventory; C.I.=confidence interval; ECOG=Eastern Cooperative Oncology Group; HR=hazard ratio; LDH=lactic dehydrogenase; N.A.=North America; NE=not estimable; No.=number; PSA=prostate-specific antigen

A planned interim analysis for OS was conducted after 333 deaths were observed. At this time, the IDMC determined that equipoise no longer existed between the study arms and recommended the trial be unblinded based on the statistically and clinically significant improvements in rPFS, together with improvements in other clinically important secondary endpoints and a positive trend towards improved overall survival. As a result, patients in the placebo group were offered treatment with ZYTIGA[®]. Overall survival at the IA was longer for ZYTIGA[®] than placebo with a 25% reduction in risk of death (HR = 0.752; 95 % CI: 0.606 - 0.934, p=0.0097) but OS was not mature and the results did not meet the pre-specified value for statistical significance of 0.0008 (Table 9). Overall survival continued to be followed after this interim analysis.

The planned final analysis for OS was conducted after 741 deaths were observed (median follow-up of 49 months). Sixty five percent (354 of 546) of patients treated with ZYTIGA[®], compared with 71% (387 of 542) of patients treated with placebo, had died. A statistically significant OS benefit in favor of the ZYTIGA[®]-treated group was demonstrated with a 19.4% reduction in risk of death (HR=0.806; 95% CI: [0.697, 0.931], p = 0.0033) and an improvement in median OS of 4.4 months (ZYTIGA[®] 34.7 months, placebo 30.3 months) (see Table 9 and Figure 3). Sixty seven percent of patients treated with abiraterone acetate and 80% of patients treated with placebo received

subsequent therapies that had the potential to prolong OS for this patient population. Subsequent therapies included abiraterone acetate, 69 (13%) and 238 (44%); docetaxel, 311 (57%) and 331 (61%); cabazitaxel, 100 (18%) and 105 (19%); and enzalutamide 87 (16%) and 54 (10%) for patients receiving abiraterone acetate or placebo, respectively. Survival analyses by subgroup are presented in Figure 4.

Table 9: Overall Survival of Asymptomatic or mildly symptomatic mCRPC Patients Treated with Either ZYTIGA® or Placebo in Combination with Prednisone Plus GnRH Agonists or Prior Orchiectomy (ITT Population)

	ZYTIGA® N=546	Placebo N=542
Interim Analysis		
Deaths	147 (27%)	186 (34%)
Median OS (months) (95% CI)	Not reached (NE, NE)	27.2 (25.95, NE)
Hazard ratio** (95% CI)	0.752 (0.606, 0.934)	
p-value*	0.0097	
Final Survival Analysis		
Deaths	354 (65%)	387 (71%)
Median OS (months) (95% CI)	34.7 (32.7, 36.8)	30.3 (28.7, 33.3)
Hazard ratio** (95% CI)	0.806 (0.697, 0.931)	
p-value*	0.0033	

NE=Not Estimated

* From a log-rank test of the equality of two survival curves over the time interval, and stratified by baseline ECOG score (0 or 1)

** Hazard Ratio is derived from a stratified proportional hazards model. Hazard ratio <1 favors ZYTIGA®

Figure 3: Kaplan Meier Survival Curves of Patients Treated with Either ZYTIGA® or Placebo in Combination with Prednisone plus GnRH Agonists or Prior Orchiectomy (Final analysis; ITT Population)

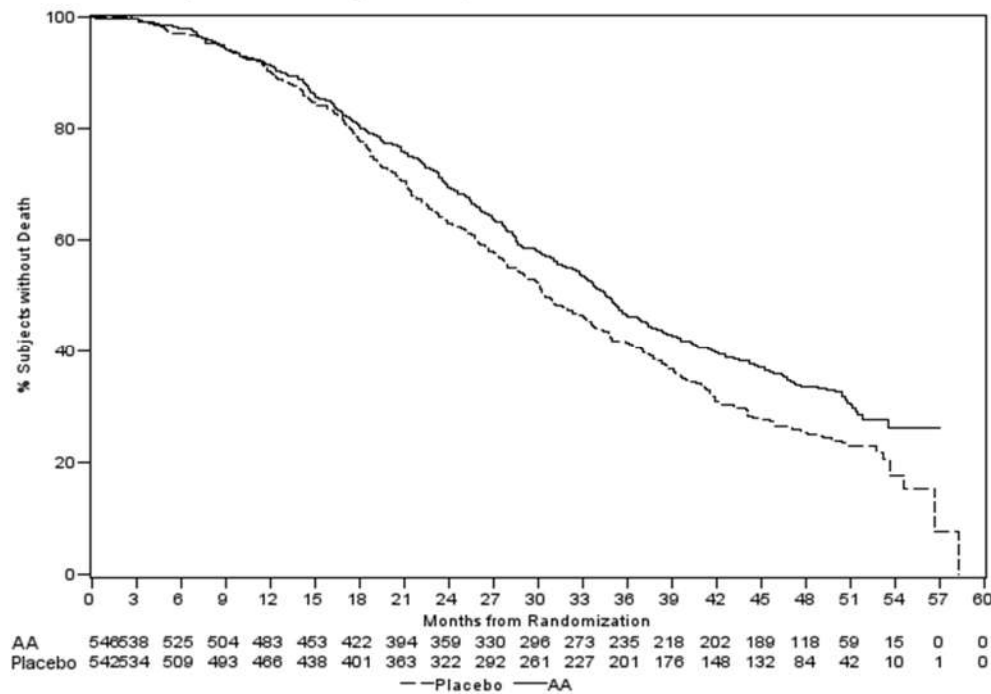
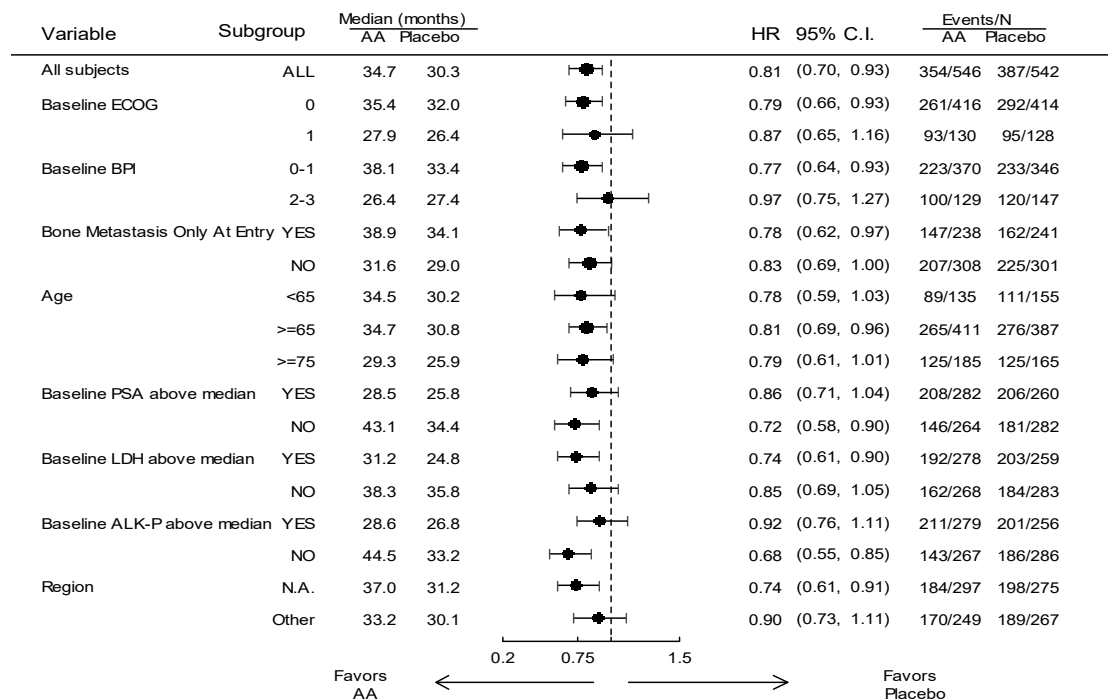

Figure 4: Overall Survival by Subgroup (Final Analysis) (ITT Population)



AA=ZYTIGA®; ALK-P=alkaline phosphatase; BPI=Brief Pain Inventory; C.I.=confidence interval; ECOG=Eastern Cooperative Oncology Group performance score; HR=hazard ratio; LDH=lactic dehydrogenase; N.A.=North America; NE=not evaluable

Subgroup analyses showed a consistent but significant rPFS effect and a consistent trend in overall survival effect favoring treatment with ZYTIGA[®].

The observed improvements in the co-primary efficacy endpoints of OS and rPFS were supported by clinical benefit favoring ZYTIGA[®] vs. placebo treatment in the following prospectively assessed secondary endpoints as follows:

Time to opiate use for cancer pain: The median time to opiate use for prostate cancer pain was 33.4 months for patients receiving ZYTIGA[®] and was 23.4 months for patients receiving placebo (HR=0.721; 95% CI: [0.614, 0.846], p=0.0001).

Time to initiation of cytotoxic chemotherapy: The median time to initiation of cytotoxic chemotherapy was 25.2 months for patients receiving ZYTIGA[®] and 16.8 months for patients receiving placebo (HR=0.580; 95% CI: [0.487, 0.691], p<0.0001).

Time to deterioration in ECOG performance score: The median time to deterioration in ECOG performance score by ≥ 1 point was 12.3 months for patients receiving ZYTIGA[®] and 10.9 months for patients receiving placebo (HR=0.821; 95% CI: [0.714, 0.943], p=0.0053).

PSA Based Endpoints: PSA-based endpoints are not validated surrogate endpoints of clinical benefit in this patient population. Nevertheless, patients receiving ZYTIGA[®] demonstrated a significantly higher total PSA response rate (defined as a $\geq 50\%$ reduction from baseline), compared with patients receiving placebo: 62% versus 24%, p<0.0001. The median time to PSA progression (time interval from randomization to PSA progression, according to PSAWG criteria) was 11.1 months for patients treated with ZYTIGA[®] and 5.6 months for patients treated with placebo (HR=0.488; 95% CI: [0.420, 0.568], p<0.0001).

Placebo-controlled Phase 3 Study in mCRPC Patients with Prior Docetaxel Treatment (Study 301)

Study design and patient demographics

In this study, the efficacy of ZYTIGA[®] was established in patients with mCRPC who had received prior chemotherapy containing docetaxel. Patients continued to be treated with a GnRH agonist during study treatment or were previously treated with orchiectomy (N=1195). Patients were randomized 2:1 to receive either ZYTIGA[®] or placebo. In the active treatment arm, ZYTIGA[®] was administered orally at a dose of 1 g daily in combination with low dose prednisone 5 mg twice daily (N=797). Control patients received placebo and low dose prednisone 5 mg twice daily (N=398).

Patients were not included in the study if they had clinically significant heart disease, (as evidenced by myocardial infarction, or arterial thrombotic events in the past 6 months, severe or unstable angina, or LVEF <50% or New York Heart Association Class III or IV heart failure), prior ketoconazole for the treatment of prostate cancer, a history of adrenal gland or pituitary disorders or prostate tumor showing extensive small cell (neuroendocrine) histology. Spironolactone was a restricted concomitant therapy due to its potential to stimulate disease progression.

The primary efficacy endpoint was OS.

PSA serum concentration independently does not always predict clinical benefit. In this study it was also recommended that patients be maintained on their study drugs until there was PSA progression (confirmed 25% increase over the patient's baseline/nadir) together with protocol-defined radiographic progression and symptomatic or clinical progression.

Table 10 summarizes key demographics and baseline disease characteristics. Demographics and baseline disease characteristics were balanced between the two groups.

Table 10: Key Demographics and Baseline Disease Characteristics Phase 3 Study in mCRPC patients with prior Docetaxel treatment: ITT Population

	ZYTIGA®+ Prednisone (N=797)	Placebo + Prednisone (N=398)	Total (N=1195)
Age (years)			
N	797	397	1194
Mean (SD)	69.1 (8.40)	68.9 (8.61)	69.0 (8.46)
Median	69.0	69.0	69.0
Range	(42, 95)	(39, 90)	(39, 95)
Sex			
N	797	398	1195
Male	797 (100.0%)	398 (100.0%)	1195 (100.0%)
Race			
N	796	397	1193
White	743 (93.3%)	368 (92.7%)	1111 (93.1%)
Black	28 (3.5%)	15 (3.8%)	43 (3.6%)
Asian	11 (1.4%)	9 (2.3%)	20 (1.7%)
Other	14 (1.8%)	5 (1.3%)	19 (1.6%)
Time since initial diagnosis to first dose(days)			
N	791	394	1185
Mean (SD)	2610.9 (1630.21)	2510.1 (1712.36)	2577.4 (1657.93)
Median	2303.0	1928.0	2198.0
Range	(175, 9129)	(61, 8996)	(61, 9129)
Evidence of disease progression			
N	797	398	1195
PSA only	238 (29.9%)	125 (31.4%)	363 (30.4%)
Radiographic progression with or without PSA progression	559 (70.1%)	273 (68.6%)	832 (69.6%)
Extent of disease			
Bone	709 (89.2%)	357 (90.4%)	1066 (89.6%)
Soft tissue, not otherwise specified	0	0	0
Node	361 (45.4%)	164 (41.5%)	525 (44.1%)
Viscera, not otherwise specified	1 (0.1%)	0 (0.0%)	1 (0.1%)
Liver	90 (11.3%)	30 (7.6%)	120 (10.1%)
Lungs	103 (13.0%)	45 (11.4%)	148 (12.4%)
Prostate mass	60 (7.5%)	23 (5.8%)	83 (7.0%)
Other viscera	46 (5.8%)	21 (5.3%)	67 (5.6%)
Other tissue	40 (5.0%)	20 (5.1%)	60 (5.0%)
ECOG performance status			
N	797	398	1195
0 or 1	715 (89.7%)	353 (88.7%)	1068 (89.4%)
2	82 (10.3%)	45 (11.3%)	127 (10.6%)
Pain			
N	797	398	1195
Present	357 (44.8%)	179 (45.0%)	536 (44.9%)
Absent	440 (55.2%)	219 (55.0%)	659 (55.1%)

	ZYTIGA [®] + Prednisone (N=797)	Placebo + Prednisone (N=398)	Total (N=1195)
Baseline PSA (ng/mL)			
N	788	393	1181
Mean (SD)	439.18 (888.476)	400.58 (810.549)	426.33 (863.173)
Median	128.80	137.70	131.40
Range	(0.4, 9253.0)	(0.6, 10114.0)	(0.4, 10114.0)

Eleven percent of patients enrolled had an ECOG performance score of 2; 70% had radiographic evidence of disease progression with or without PSA progression; 70% had received one prior cytotoxic chemotherapy and 30% received two. As required in the protocol, 100% of patients had received docetaxel therapy prior to treatment with ZYTIGA[®]. All docetaxel containing regimens were considered as one line of therapy. Liver metastasis was present in 11% of patients treated with ZYTIGA[®].

Study results

A median of 8 cycles (32 weeks) were administered in the abiraterone acetate group compared with 4 cycles (16 weeks) in the placebo group. The proportion of patients who required dose reductions was low; 4% in the abiraterone acetate group and 1% in the placebo group had dose reductions and 17% and 16%, respectively, required dose interruptions.

In a planned interim analysis conducted after 552 deaths were observed, 42% (333 of 797) of patients treated with ZYTIGA[®], compared with 55% (219 of 398) of patients treated with placebo, had died. A statistically significant improvement in median overall survival was seen in patients treated with ZYTIGA[®] (see Table 11 and Figure 5).

An updated survival analysis was conducted when 775 deaths (97% of the planned number of deaths for final analysis) were observed. Results from this analysis were consistent with those from the interim analysis (Table 11).

Table 11: Overall Survival of Patients Treated with Either ZYTIGA[®] or Placebo in Combination with Prednisone Plus GnRH Agonists or Prior Orchiectomy

	ZYTIGA [®] (N=797)	Placebo (N=398)
Primary Survival Analysis		
Deaths (%)	333 (42%)	219 (55%)
Median survival (months) (95% CI)	14.8 (14.1, 15.4)	10.9 (10.2, 12.0)
p-value ^a	<0.0001	
Hazard ratio (95% CI) ^b	0.646 (0.543, 0.768)	
Updated Survival Analysis		
Deaths (%)	501 (63%)	274 (69%)
Median survival (months) (95% CI)	15.8 (14.8, 17.0)	11.2 (10.4, 13.1)
Hazard ratio (95% CI) ^b	0.740 (0.638, 0.859)	

^a P-value is derived from a log-rank test stratified by ECOG performance status score (0–1 vs. 2), pain score (absent vs. present), number of prior chemotherapy regimens (1 vs. 2), and type of disease progression (PSA only vs. radiographic).

^b Hazard ratio is derived from a stratified proportional hazards model. Hazard ratio < 1 favors ZYTIGA[®].

At all evaluation time points after the initial few months of treatment, a higher proportion of patients treated with ZYTIGA[®] remained alive, compared with the proportion of patients treated with placebo (see Figure 5).

Figure 5: Kaplan Meier Survival Curves of Patients Treated with either ZYTIGA[®] or Placebo in Combination with Prednisone plus GnRH Agonists or Prior Orchiectomy (planned interim analysis)

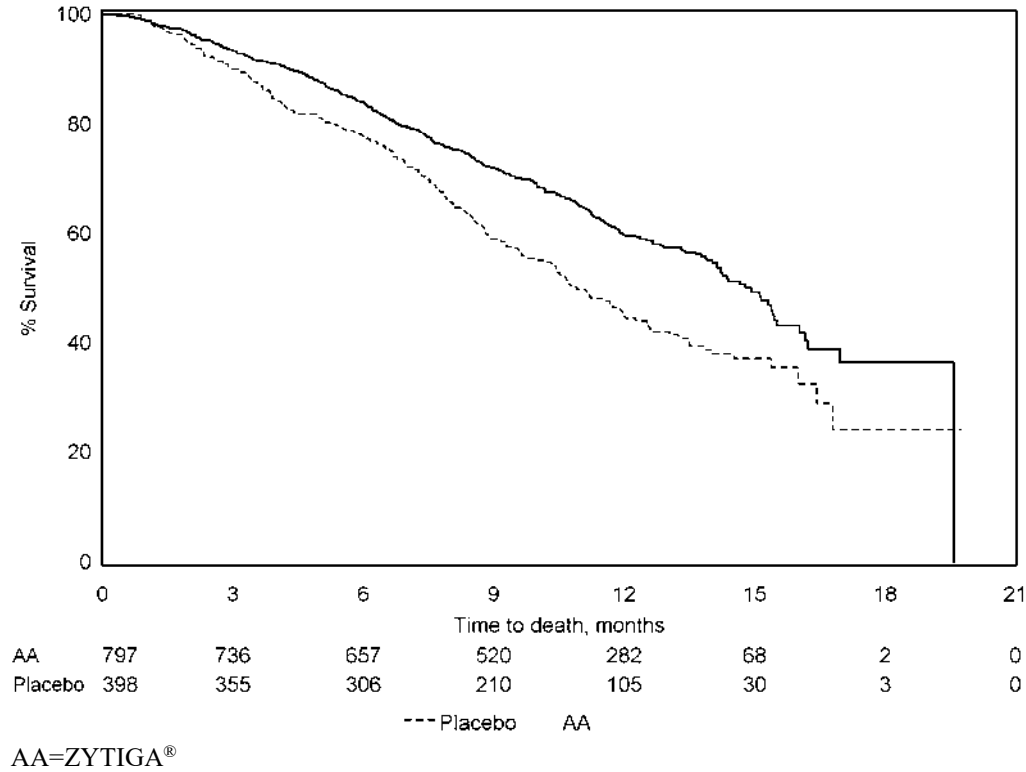

Survival analyses by subgroup are presented in Figure 6.

Figure 6: Overall Survival by Subgroup

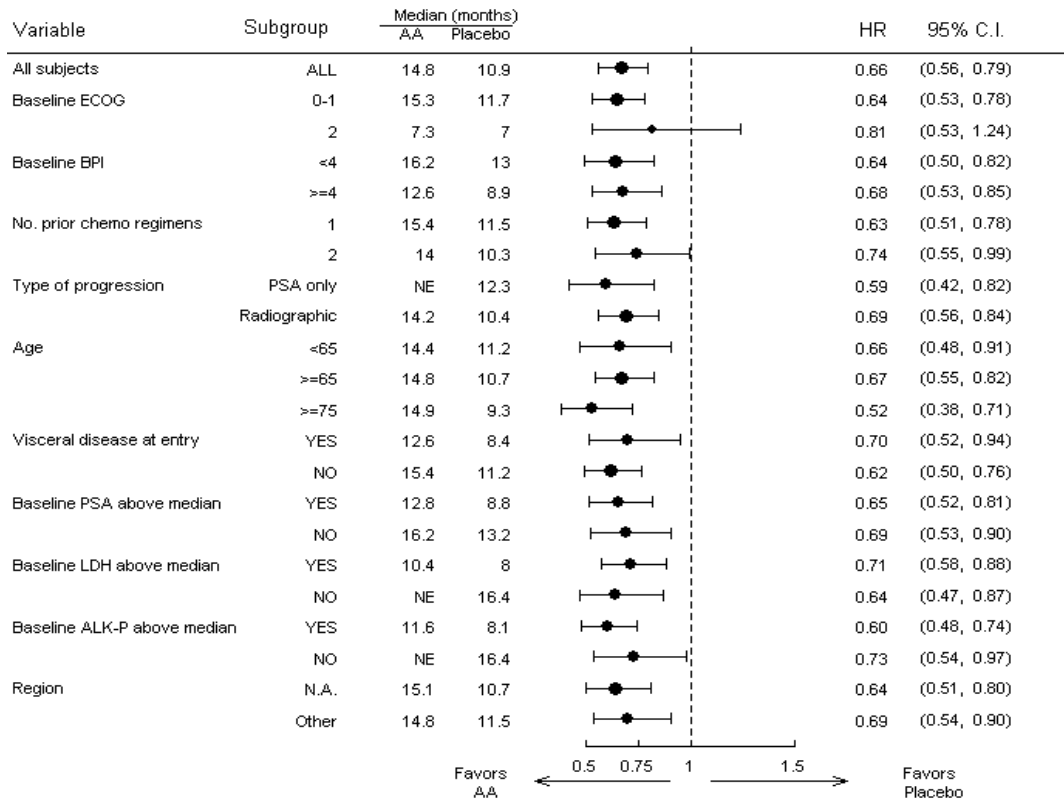

AA=ZYTIGA[®]; ALK-P=alkaline phosphatase; BPI=Brief Pain Inventory; C.I.=confidence interval; ECOG=Eastern Cooperative Oncology Group performance score; HR=hazard ratio; LDH=lactic dehydrogenase; N.A.=North America; NE=not evaluable

Subgroup analyses showed a consistent favorable survival effect for treatment with ZYTIGA[®] by presence of pain at baseline, 1 or 2 prior chemotherapy regimens, type of progression, baseline PSA score above median and presence of visceral disease at entry.

In addition to the observed improvement in overall survival, all secondary study endpoints favored ZYTIGA[®] and were statistically significant after adjusting for multiple testing. PSA-based endpoints are not validated surrogate endpoints of clinical benefit in this patient population. Nevertheless, patients receiving ZYTIGA[®] demonstrated a significantly higher total PSA response rate (defined as a $\geq 50\%$ reduction from baseline), compared with patients receiving placebo: 38% versus 10%, $p < 0.0001$. The median time to PSA progression (time interval from randomization to PSA progression, according to PSAWG criteria) was 10.2 months for patients treated with ZYTIGA[®] and 6.6 months for patients treated with placebo (HR=0.580; 95% CI: [0.462, 0.728], $p < 0.0001$).

The rPFS was the time from randomization to the occurrence of either tumor progression in soft tissue according to modified RECIST criteria (with CT or MRI, until an increase above baseline of at least 20% in the longest diameter of target lesions or the appearance of new lesions), or by bone scan (≥ 2 new lesions). A confirmatory bone scan was not mandatory. The median rPFS was 5.6

months for patients treated with ZYTIGA[®] and 3.6 months for patients who received placebo (HR=0.673; 95% CI: [0.585, 0.776], p<0.0001).

Pain

The proportion of patients with pain palliation was statistically significantly higher in the ZYTIGA[®] group than in the placebo group (44% versus 27%, p=0.0002). A responder for pain palliation was defined as a patient who experienced at least a 30% reduction from baseline in the Brief Pain Inventory – Short Form (BPI-SF) worst pain intensity score over the last 24 hours without any increase in analgesic usage score observed at two consecutive evaluations four weeks apart. Only patients with a baseline pain score of ≥ 4 and at least one post-baseline pain score were analyzed (N=512) for pain palliation.

Pain progression was defined as an increase from baseline of $\geq 30\%$ in the BPI-SF worst pain intensity score over the previous 24 hours without a decrease in analgesic usage score observed at two consecutive visits, or an increase of $\geq 30\%$ in analgesic usage score observed at two consecutive visits. The time to pain progression at the 25th percentile was 7.4 months in the ZYTIGA[®] group, versus 4.7 months in the placebo group.

Skeletal-Related Events

The time to first skeletal-related event at the 25th percentile in the ZYTIGA[®] group was twice that of the control group at 9.9 months vs. 4.9 months. A skeletal-related event was defined as a pathological fracture, spinal cord compression, palliative radiation to bone, or surgery to bone.

Placebo-controlled Phase 3 Study in Newly Diagnosed High-Risk Metastatic Prostate Cancer Patients (Study 3011 – LATITUDE)

Study design and patient demographics

The study enrolled patients who were diagnosed with metastatic prostate cancer within 3 months of randomization and had high-risk prognostic factors. Patients could have received up to 3 months of prior ADT treatment. High-risk prognosis was defined as having at least 2 of the following 3 risk factors: (1) Gleason score of ≥ 8 ; (2) presence of 3 or more lesions on bone scan; (3) presence of measurable visceral (excluding lymph node disease) metastasis. In the active arm, ZYTIGA[®] was administered at a dose of 1 g daily in combination with low dose prednisone or prednisolone 5 mg once daily in addition to ADT (GnRH agonist or orchiectomy), which was the standard of care treatment. Patients in the control arm received ADT and placebos for both ZYTIGA[®] and prednisone. Patients with uncontrolled hypertension, significant heart disease, or NYHA Class II or worse heart failure were excluded.

Co-primary efficacy endpoints were OS and rPFS. Radiographic progression-free survival was defined as the time from randomization to the occurrence of radiographic progression or death from any cause. Radiographic progression included progression by bone scan (according to modified PCWG2) or progression of soft tissue lesions by CT or MRI (according to RECIST 1.1). Secondary endpoints included time to skeletal-related event (SRE), time to subsequent therapy for prostate cancer, time to initiation of chemotherapy, time to pain progression and time to PSA progression. Treatment continued until disease progression, withdrawal of consent, the occurrence of unacceptable toxicity, or death.

The key demographics and baseline characteristics are shown in Table 12 below.

Table 12: Key Demographics and Baseline Disease Characteristics (Phase 3 Study in Newly Diagnosed High-Risk Metastatic Prostate Cancer Patients: ITT Population)

	ZYTIGA® + Prednisone + ADT (N=597)	Placebo + ADT (N=602)	Total (N=1199)
Age (years)			
N	597	602	1199
Mean (SD)	67.3 (8.48)	66.8 (8.72)	67.1 (8.60)
Median	68.0	67.0	67.0
Range	(38; 89)	(33; 92)	(33; 92)
Sex			
N	597	602	1199
Male	597 (100.0%)	602 (100.0%)	1199 (100.0%)
Race			
N	597	602	1199
White	409 (68.5%)	423 (70.3%)	832 (69.4%)
Black or African American	15 (2.5%)	10 (1.7%)	25 (2.1%)
Asian	125 (20.9%)	121 (20.1%)	246 (20.5%)
Other	43 (7.2%)	37 (6.1%)	80 (6.7%)
Time from initial diagnosis to first dose (months)			
N	597	602	1199
Mean (SD)	1.8 (0.73)	1.9 (0.75)	1.9 (0.74)
Median	1.8	2.0	1.8
Range	(0; 3)	(0; 4)	(0; 4)
Current Extent of Disease			
N	596	600	1196
Bone	580 (97.3%)	585 (97.5%)	1165 (97.4%)
Liver	32 (5.4%)	30 (5.0%)	62 (5.2%)
Lungs	73 (12.2%)	72 (12.0%)	145 (12.1%)
Node	283 (47.5%)	287 (47.8%)	570 (47.7%)
Prostate mass	151 (25.3%)	154 (25.7%)	305 (25.5%)
Viscera	18 (3.0%)	13 (2.2%)	31 (2.6%)
Soft tissue	9 (1.5%)	15 (2.5%)	24 (2.0%)
Other	2 (0.3%)	0	2 (0.2%)
Subjects with high risk at Screening (IWRS)			
GS \geq 8 + \geq 3 bone lesions	597 (100.0%)	601 (99.8%)	1198 (99.9%)
GS \geq 8 + Measurable visceral	573 (96.0%)	569 (94.7%)	1142 (95.3%)
\geq 3 bone lesions + Measurable visceral	82 (13.7%)	87 (14.5%)	169 (14.1%)
GS \geq 8 + \geq 3 bone lesions + Measurable visceral	84 (14.1%)	85 (14.1%)	169 (14.1%)
GS \geq 8 + \geq 3 bone lesions + Measurable visceral	71 (11.9%)	70 (11.6%)	141 (11.8%)
Baseline Pain score (BPI-SF Item3)			
N	570	579	1149
Mean (SD)	2.2 (2.45)	2.2 (2.40)	2.2 (2.42)
ECOG performance status at baseline			
N	597	602	1199
0	326 (54.6%)	331 (55.0%)	657 (54.8%)
1	245 (41.0%)	255 (42.4%)	500 (41.7%)
2	26 (4.4%)	16 (2.7%)	42 (3.5%)
Baseline PSA (ng/mL)			
N	595	600	1195
Mean (SD)	263.24 (791.440)	201.67 (647.807)	232.33 (723.252)
Median	25.43	23.05	23.85
Range	(0.0; 8775.9)	(0.1; 8889.6)	(0.0; 8889.6)
Baseline Hemoglobin (g/L)			
N	597	602	1199
Mean (SD)	130.52 (16.959)	131.57 (17.430)	131.05 (17.198)

	ZYTIGA [®] + Prednisone + ADT (N=597)	Placebo + ADT (N=602)	Total (N=1199)
Median	132.00	133.00	132.00
Range	(90.0; 175.0)	(89.0; 174.0)	(89.0; 175.0)
Baseline Lactate Dehydrogenase (U/L)			
N	591	595	1186
Mean (SD)	199.3 (133.11)	193.6 (104.22)	196.4 (119.47)
Median	177.0	176.0	177.0
Range	(73; 2634)	(67; 1444)	(67; 2634)

Study results

A median of 28 cycles (112 weeks) were administered in the ZYTIGA[®] group compared with 15 cycles (62 weeks) in the placebo group. The median total treatment duration was 26 months in the ZYTIGA[®] group and 14 months in the placebo group.

At the planned rPFS analysis there were 593 events; 239 (40.0%) of patients treated with ZYTIGA[®] and 354 (58.8%) of patients treated with placebo had radiographic evidence of progression or had died. A statistically significant difference in rPFS between treatment groups was observed (see Table 13 and Figure 7). rPFS analyses by subgroup are presented in Figure 8.

Table 13: Radiographic Progression-Free Survival - Stratified Analysis; ITT Population (Study 3011)

	ZYTIGA [®] + Prednisone N=597	Placebo N=602
Event	239 (40.0%)	354 (58.8%)
Median rPFS (95% CI)	33.02 (29.57, NE)	14.78 (14.69, 18.27)
Hazard ratio (95% CI) ^b	0.466 (0.394, 0.550)	
p value ^a	<0.0001	

+ = censored observation, NE = not estimable. The radiographic progression and death are considered in defining the rPFS event.

^a p value is from a log-rank test stratified by ECOG PS score (0/1 or 2) and visceral (absent or present).

^b Hazard ratio is from stratified proportional hazards model. Hazard ratio <1 favors ZYTIGA[®].

Figure 7: Kaplan-Meier Plot of rPFS; ITT Population (Study PCR3011)

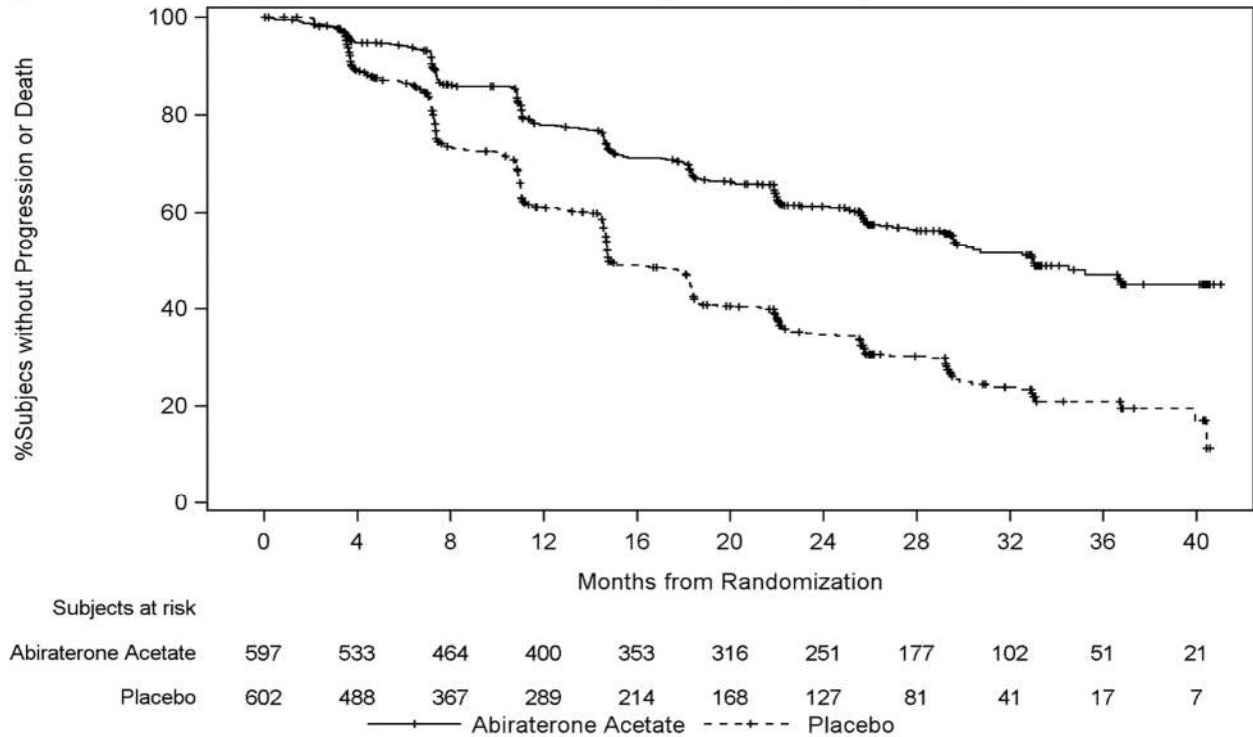

Figure 8: rPFS by Subgroup; ITT population (Study PCR3011)

Variable	Subgroup	Median (month)		HR 95% C.I.	Events/N	
		AA-P	Placebo		AA-P	Placebo
All Subjects	All	33	14.8	0.47 (0.40, 0.55)	239/597	354/602
Age	<65	30.7	14.6	0.44 (0.34, 0.58)	96/221	141/233
	>=65	34.5	18.2	0.49 (0.39, 0.60)	143/376	213/369
	>=75	30.1	22	0.64 (0.44, 0.95)	45/123	59/120
ECOG	0/1	34.5	14.8	0.44 (0.37, 0.52)	223/573	347/586
	2	11.3	31	2.43 (0.98, 6.02)	16/24	7/16
Visceral Disease	Yes	30.7	18.3	0.53 (0.37, 0.76)	51/114	70/114
	No	34.5	14.8	0.45 (0.38, 0.55)	188/483	284/488
Gleason Score	<8	NE	19.4	0.47 (0.15, 1.46)	5/13	9/16
	>=8	33	14.8	0.47 (0.40, 0.55)	234/584	345/586
Bone Lesions	<=10	NE	21.9	0.44 (0.32, 0.59)	68/211	124/221
	>10	29.6	14.7	0.47 (0.38, 0.57)	171/386	230/381
Above Median PSA	Yes	30.7	18.1	0.52 (0.41, 0.66)	122/304	157/293
	No	33.1	14.8	0.43 (0.34, 0.55)	117/293	195/307
Above Median LDH	Yes	29.6	15	0.58 (0.46, 0.73)	138/294	161/284
	No	NE	14.9	0.36 (0.28, 0.47)	98/297	189/311
Region	Asia	NE	22.1	0.32 (0.20, 0.50)	29/124	60/121
	East Europe	29.2	12.9	0.43 (0.33, 0.56)	99/214	155/217
	West Europe	27	14.6	0.49 (0.36, 0.68)	65/155	87/162
	Rest of World	27.9	21.9	0.73 (0.49, 1.08)	46/104	52/102

0.1 1 10
 Favoring AA-P Favoring Placebo
 Hazard Ratio (AA-P vs. Placebo) & 95% C.I. (Log Scale)

AA-P = ZYTIGA®+Prednisone

At the planned first interim analysis (IA-1) for overall survival, four hundred and six deaths had occurred. A statistically significant improvement in OS in favor of ZYTIGA[®] plus ADT was observed (Table 14). The study was unblinded based on the results of the interim OS analysis and patients in the placebo group were offered treatment with ZYTIGA[®]. Survival continued to be followed after this IA.

As of the clinical cut-off for the final analysis, 618 deaths were reported: 275 (46%) in the ZYTIGA[®] plus ADT group and 343 (57%) in the placebo group. The median follow-up time for all patients was 51.8 months. Significant improvement in OS was demonstrated in the ZYTIGA[®]-treated group compared with the placebo group, showing a consistent and robust treatment effect in favor of ZYTIGA[®] treatment (Table 14, Figure 9). OS analysis by subgroups is shown in Figure 10.

Table 14: Overall Survival, Stratified Analysis; ITT Population (Study PCR3011)

	ZYTIGA [®] + Prednisone N=597	Placebo N=602
Interim Analysis		
Event	169 (28.3%)	237 (39.4%)
Median Survival (months) (95% CI)	NE (NE, NE)	34.73 (33.05, NE)
Hazard ratio (95% CI) ^b	0.621 (0.509, 0.756)	
p value ^a	<0.0001	
Final Analysis		
Event	275 (46.1%)	343 (57.0%)
Median Survival (months) (95% CI)	53.32 (48.23, NE)	36.53 (33.54, 39.95)
Hazard ratio (95% CI) ^b	0.661 (0.564, 0.775)	
p value ^a	<0.0001	

+ = censored observation, NE = not estimable.

^a p value is from log-rank test stratified by ECOG PS score (0/1 or 2) and visceral (absent or present).

^b Hazard ratio is from stratified proportional hazards model. Hazard ratio <1 favors ZYTIGA[®].

Figure 9:Kaplan-Meier Plot of Overall Survival; ITT Population (Study PCR3011)

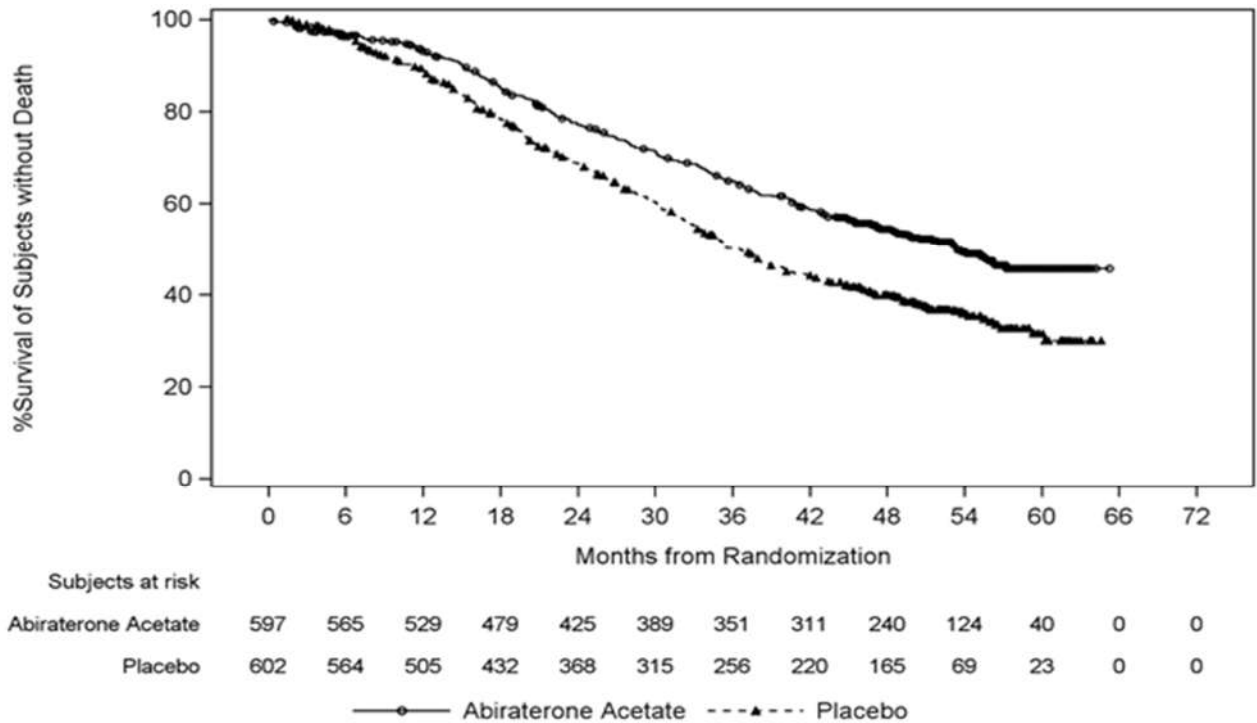
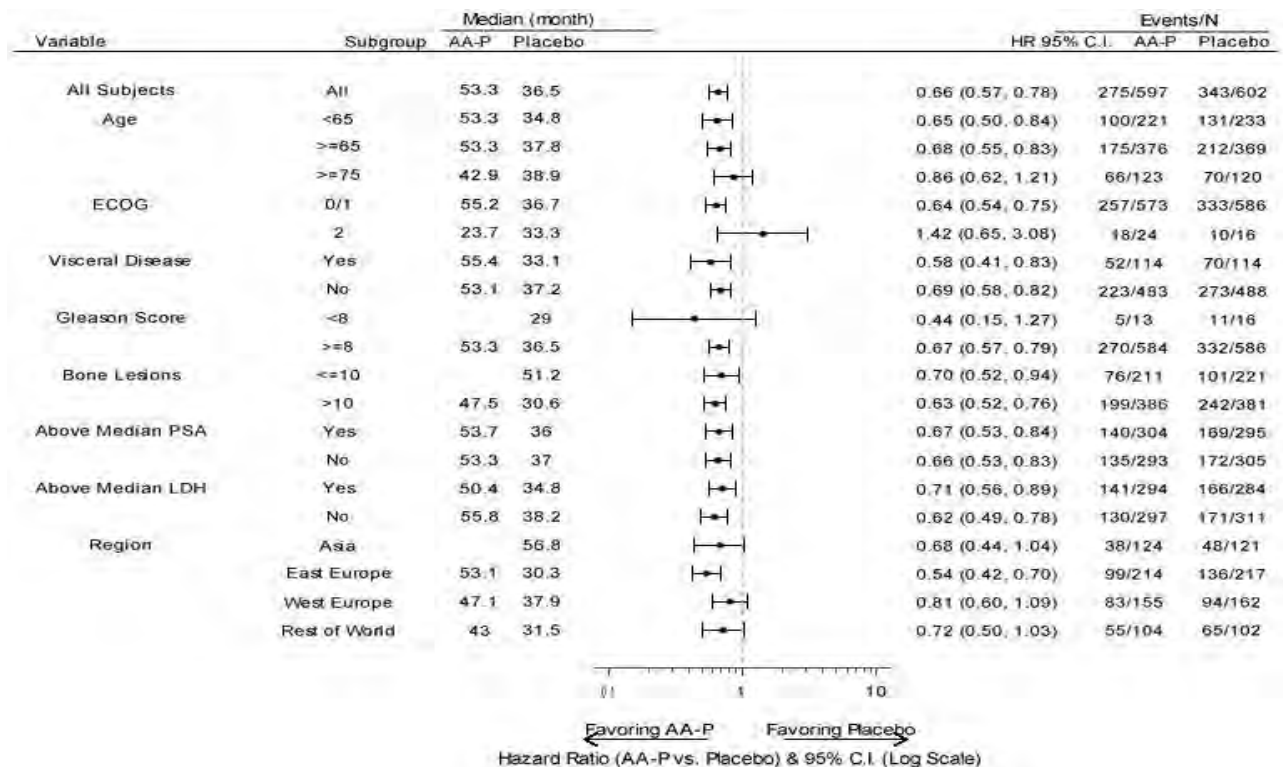

Figure 10: Overall Survival by Subgroup; ITT population (Study PCR3011)



AA-P = ZYTIGA®+Prednisone

The Secondary endpoint measures at the time of the final analysis were as follows:

Time to skeletal-related event (SRE): Time to skeletal-related event was defined as the earliest of the following: clinical or pathological fracture, spinal cord compression, palliative radiation to bone, or surgery to bone. Skeletal-related events were reported for 22% of patients on ZYTIGA[®] and 25% on placebo. There was a 24% reduction in the risk of skeletal-related events (HR=0.759; 95% CI: [0.601, 0.960]; p<0.0208). The median time to SRE has not been reached for the ZYTIGA[®] or placebo study arm.

Time to PSA progression based on PCWG2 criteria: Time to PSA progression was defined as the time interval from the date of randomization to the date of PSA progression, according to Prostate Cancer Working Group 2 (PCWG2) criteria. The median time to PSA progression based on PCWG2 criteria was 33.3 months for patients receiving ZYTIGA[®] and 7.4 months for patients receiving placebo (HR=0.310; 95% CI: [0.266, 0.363]; p<0.0001).

Time to subsequent therapy for prostate cancer: Forty one percent of patients treated with ZYTIGA[®] and 59% of patients treated with placebo, received subsequent therapies that had the potential to prolong OS for this patient population. The median time to subsequent therapy was 54.9 months in the ZYTIGA[®] plus ADT group and was 21.2 months in the placebo group (HR=0.448; 95% CI: 0.380, 0.528; p<0.0001). Subsequent therapies included docetaxel (24% and 35% of patients treated with ZYTIGA[®] and placebo, respectively), enzalutamide (9% and 16%), cabazitaxel (4% and 8%), radium-223 dichloride (4% and 7%), and abiraterone acetate (3% and 14%).

Time to initiation of chemotherapy: Time to initiation of chemotherapy was defined as the time interval from the date of randomization to the date of initiation of chemotherapy for prostate cancer. The median time to initiation of chemotherapy was not reached for patients receiving ZYTIGA[®] and was 57.6 months for patients receiving placebo (HR=0.508; 95% CI: [0.412, 0.627]; p<0.0001).

Time to pain progression: Time to pain progression was defined as the time interval from randomization to the first date a subject experienced a $\geq 30\%$ increase from baseline in the Brief Pain Inventory – Short Form (BPI-SF) worst pain intensity (Item 3) observed at 2 consecutive evaluations ≥ 4 weeks apart. Pain progression was reported in 41% of patients on ZYTIGA[®] and 49% of patients on placebo. The median time to pain progression was 47.4 months for patients receiving ZYTIGA[®] and 16.6 months for patients receiving placebo (HR=0.721; 95% CI: [0.607, 0.857], p<0.0002).

DETAILED PHARMACOLOGY

Non-clinical pharmacokinetics

Several isoenzymes (CYP, UGT and SULT) are responsible for the metabolism of abiraterone into 15 detectable metabolites, accounting for approximately 92% of circulating radioactivity. CYP3A4 and SULT2A1 are the major single isoenzymes involved in metabolite formation with a minor contribution from UGT1A4, SULT1E1 and UGT1A3.

In vitro studies with human hepatic microsomes demonstrated that abiraterone was not an inhibitor for human CYP2A6 and CYP2E1. In these same studies, abiraterone was a moderate inhibitor of CYP2C9, CYP2C19 and CYP3A4/5. However, the concentrations of abiraterone in patients were lower than the concentration required for clinically meaningful inhibition of these enzymes.

Abiraterone was also determined *in vitro* to be a potent inhibitor of CYP1A2, CYP2D6 and CYP2C8 (see **Drug-Drug Interactions**).

The pharmacokinetics of abiraterone in the presence of strong inducers or inhibitors of the above enzymes have not been evaluated *in vitro* or *in vivo* with the exception of CYP3A4 (see **Drug-Drug Interactions**, *CYP3A4 inducers* and *CYP3A4 inhibitors*).

TOXICOLOGY

In 13- and 26-week repeated dose studies in rats and 13- and 39-week repeated dose studies in monkeys, a reduction in circulating testosterone levels occurred with abiraterone at approximately one half the human clinical exposure based on AUC. As a result, morphological and/or histopathological changes were observed in the reproductive organs. These included aspermia/hypospermia, atrophy/weight reductions in the male genital tract organs and testes. In addition, adrenal gland hypertrophy, Leydig cell hyperplasia, pituitary gland hyperplasia and mammary gland hyperplasia were observed. The changes in the reproductive organs and androgen-sensitive organs are consistent with the pharmacology of abiraterone. All treatment-related changes were partially or fully reversed after a four-week recovery period.

After chronic treatment from 13 weeks onward, hepatocellular hypertrophy was observed in rats only at exposure levels of abiraterone 0.72-fold the human clinical exposure based on AUC. Bile duct/oval cell hyperplasia, associated with increased serum alkaline phosphatase and/or total bilirubin levels, was seen in the liver of rats (at exposure levels of abiraterone 3.2-fold the human clinical exposure based on AUC) and monkeys (at exposure levels of abiraterone 1.2-fold the human clinical exposure based on AUC). After a four-week recovery period, serum parameters reversed, whereas bile duct/oval cell hyperplasia persisted.

A dose dependent increase in cataracts was observed after 26 weeks of treatment in rats at exposure levels of abiraterone 1.1 times the human clinical exposure based on AUC. These changes were irreversible after a four-week recovery period. Cataracts were not observed in monkeys after 13 or 39 weeks of treatment at exposure levels 2-fold greater than the clinical exposure based on AUC.

Reproductive Toxicology

In fertility studies in rats, reduced organ weights of the reproductive system, sperm counts, sperm motility, altered sperm morphology and decreased fertility were observed in males dosed for 4 weeks at ≥ 30 mg/kg/day. Mating of untreated females with males that received 30 mg/kg/day abiraterone acetate resulted in a reduced number of corpora lutea, implantations and live embryos and an increased incidence of pre-implantation loss. Effects on male rats were reversible after 16 weeks from the last abiraterone acetate administration. Female rats dosed for 2 weeks until day 7 of pregnancy at ≥ 30 mg/kg/day had an increased incidence of irregular or extended estrous cycles and pre-implantation loss (300 mg/kg/day). There were no differences in mating, fertility, and litter parameters in female rats that received abiraterone acetate. Effects on female rats were reversible after 4 weeks from the last abiraterone acetate administration. The dose of 30 mg/kg/day in rats is approximately 0.3 times the recommended dose of 1000 mg/day based on body surface area.

In developmental toxicity study in rats, although abiraterone acetate did not have teratogenic potential, abiraterone acetate caused developmental toxicity when administered at doses of 10, 30 or

100 mg/kg/day throughout the period of organogenesis (gestational days 6-17). Findings included embryo-fetal lethality (increased post-implantation loss and resorptions and decreased number of live fetuses), fetal developmental delay (skeletal effects) and urogenital effects (bilateral ureter dilation) at doses ≥ 10 mg/kg/day, decreased fetal ano-genital distance at ≥ 30 mg/kg/day, and decreased fetal body weight at 100 mg/kg/day. Doses ≥ 10 mg/kg/day caused maternal toxicity. The doses (10, 30, or 100 mg/kg) tested in rats resulted in systemic exposures (AUC) approximately 0.03, 0.1 and 0.3 times, respectively, the AUC in patients.

ZYTIGA[®] is contraindicated in pregnancy (see **CONTRAINDICATIONS** and **WARNINGS AND PRECAUTIONS, Special Populations**).

Carcinogenesis and Genotoxicity

Abiraterone acetate was not carcinogenic in a 6-month study in the transgenic (Tg.rasH2) mouse. In a 24-month carcinogenicity study in the rat, abiraterone acetate increased the incidence of interstitial cell neoplasms in the testes. This finding is considered related to the pharmacological action of abiraterone. The clinical relevance of this finding is not known. Abiraterone acetate was not carcinogenic in female rats.

Abiraterone acetate and abiraterone were devoid of genotoxic potential in the standard panel of genotoxicity tests, including an *in vitro* bacterial reverse mutation assay (the Ames test), an *in vitro* mammalian chromosome aberration test (using human lymphocytes) and an *in vivo* rat micronucleus assay.

REFERENCES

1. Attard G, Reid AHM and de Bono JS. Abiraterone acetate is well tolerated without concomitant use of corticosteroids. *J Clin Oncol* 2010;29:5170–1.
2. Attard G, Reid AHM, Yap TA, et al. Phase I clinical trial of a selective inhibitor of CYP17, abiraterone acetate, confirms that castration-resistant prostate cancer commonly remains hormone driven. *J Clin Oncol* 2008;26:4563–71.
3. Attard G, Reid AHM, A'Hern R, et al. Selective inhibition of CYP17 with abiraterone acetate is highly active in the treatment of castration-resistant prostate cancer. *J Clin Oncol* 2009;27:3742–8.
4. Danila DC, Morris MJ, de Bono JS, et al. Phase II multicenter study of abiraterone acetate plus prednisone therapy in patients with docetaxel-treated, castration-resistant prostate cancer. *J Clin Oncol* 2010;28:1496–1501.
5. de Bono JS, Logothetis CJ, Molina A, et al. Abiraterone and increased survival in metastatic prostate cancer. *N Engl J Med* 2011;364(21):1995–2005.
6. James ND, de Bono JS, Spears MR, et al. Abiraterone for Prostate Cancer Not Previously Treated with Hormone Therapy. *N Engl J Med*. 2017 Jun 3 [epub ahead of print].
7. Luthy A, Begin DJ and Labrie F. Androgenic activity of synthetic progestins and spironolactone in androgen-sensitive mouse mammary carcinoma (Shionogi) cells in culture. *J Steroid Biochem* 1988;31(5):845–52.
8. Ryan CJ, Smith MR, Fong L, et al. Phase I clinical trial of the CYP17 inhibitor abiraterone acetate demonstrating clinical activity in patients with castration-resistant prostate cancer who received prior ketoconazole therapy. *J Clin Oncol* 2010;28(9):1481–8.
9. Ryan CJ, Smith MR, de Bono JR, et al. Abiraterone in metastatic prostate cancer without previous chemotherapy. *N Engl J Med* 2013;368:138–48.

PART III: CONSUMER INFORMATION

Pr ZYTIGA®

Abiraterone acetate tablets, Mfr. Std.

This leaflet is Part III of a three-part "Product Monograph" published when ZYTIGA® was approved for sale in Canada and is designed specifically for Consumers. This leaflet is a summary and will not tell you everything about ZYTIGA®. Contact your doctor or pharmacist if you have any questions about the drug.

ABOUT THIS MEDICATION

What the medication is used for:

ZYTIGA®, in combination with prednisone, is used to treat prostate cancer that has spread to other parts of the body in:

- adult patients who are asymptomatic or mildly symptomatic after failure of androgen deprivation therapy (ADT).
or
- adult patients who have had prior cancer treatment with docetaxel after failure of ADT.
or
- adult patients with newly diagnosed hormone-sensitive high-risk prostate cancer who may have received up to 3 months of prior ADT.

Asymptomatic patients are defined as patients who may have no noticeable changes to health. Mildly symptomatic patients may show symptoms or changes in health such as bone pain or fatigue.

What it does:

ZYTIGA® works to stop your body from making androgens. This can slow the growth of prostate cancer. ZYTIGA® may help delay the decline in your daily activity levels and may help delay the need for drugs to treat your cancer pain.

When your prostate cancer spreads beyond the prostate to other parts of the body, this is known as metastatic prostate cancer or advanced cancer.

Androgens are a group of hormones, and testosterone belongs to this group. Testosterone is the main type of androgen. Androgens promote cancer cell growth. That is why it's so important to keep these hormones at "castrate levels" (extremely low levels), to stop the growth of cancer.

ZYTIGA® helps to block the production of even small amounts of androgens in the three places they are produced: in the testes, the adrenal glands and the prostate cancer tumor itself.

When it should not be used:

- If you are allergic (hypersensitive) to abiraterone acetate or any of the other ingredients of ZYTIGA®.
- ZYTIGA® should not be taken by women who are pregnant or might be pregnant.

- ZYTIGA® should not be taken by women who are nursing.

What the medicinal ingredient is:

Abiraterone acetate

What the nonmedicinal ingredients are:

ZYTIGA® 250 mg uncoated tablets: Colloidal silicon dioxide, croscarmellose sodium, lactose monohydrate, magnesium stearate, microcrystalline cellulose, povidone, and sodium lauryl sulfate.

ZYTIGA® 500 mg film-coated tablets: Colloidal silicon dioxide, croscarmellose sodium, hypromellose, lactose monohydrate, magnesium stearate, silicified microcrystalline cellulose, and sodium lauryl sulfate. Tablet film coating: iron oxide black, iron oxide red, macrogol 3350, polyvinyl alcohol, talc, and titanium dioxide.

What dosage forms it comes in:

250 mg uncoated tablets and 500 mg film-coated tablets.

WARNINGS AND PRECAUTIONS

Serious Warnings and Precautions

- ZYTIGA® may cause high blood pressure, low blood potassium and swelling (fluid retention).
- ZYTIGA® should be used with caution in patients with a history of heart failure, heart attack, or other heart problems.
- Patients with severe and moderate liver problems should not take ZYTIGA®.
- Cases of liver failure, some leading to death have been reported. (see below for more information).

ZYTIGA® must be taken on an empty stomach since food can increase the blood level of ZYTIGA® and this may be harmful. Do not eat any solid or liquid food two hours before taking ZYTIGA® and at least one hour after taking ZYTIGA®.

BEFORE you use ZYTIGA® talk to your doctor or pharmacist if:

- you have or have had high blood pressure, low blood potassium and irregular heartbeats
- you have or have had heart failure, heart attack, or other heart problems
- you have liver problems
- you have or have had adrenal problems

ZYTIGA® may affect your liver. Rarely, failure of the liver to function (called acute liver failure) may occur, which can lead to death. Talk to your doctor if you develop yellowing of the skin or eyes, darkening of the urine, or severe nausea or vomiting, as these could be signs or symptoms of liver problems. When you are taking ZYTIGA® your doctor will check your blood to look for any effects of ZYTIGA® on your liver.

ZYTIGA® may harm an unborn baby. While taking

ZYTIGA[®] and for one week after the last dose of ZYTIGA[®], male patients must use a condom and another effective birth control method when having sexual activity with a woman who is pregnant or can become pregnant.

Women who are pregnant or may become pregnant should not handle ZYTIGA[®] 250 mg uncoated tablets without protective gloves.

ZYTIGA[®] should not be used in patients under 18 years of age.

INTERACTIONS WITH THIS MEDICATION

Please tell your doctor or pharmacist if you are taking or have recently taken any other medicines. This includes medicines obtained without a prescription, including herbal medicines.

Tell your physician if you are taking phenytoin, carbamazepine, rifampicin, rifabutin, phenobarbital, or St. John's wort because these medications may decrease the effect of ZYTIGA[®]. This may lead to ZYTIGA[®] not working as well as it should.

PROPER USE OF THIS MEDICATION

Always take ZYTIGA[®] exactly as your doctor has told you. You should check with your doctor or pharmacist if you are not sure.

Usual dose:

The usual dose is two 500 mg tablet or four 250 mg tablets (1g) by mouth once a day.

ZYTIGA[®] must be taken on an empty stomach

- Do not eat any solid or liquid food two hours before taking ZYTIGA[®] and at least one hour after taking ZYTIGA[®]. Taking ZYTIGA[®] with food causes more of this medicine to be absorbed by the body than is needed and this may be harmful.
- Swallow the tablets whole with a glass of water.
- Do not break the tablets.
- ZYTIGA[®] is taken with a medicine called prednisone to help manage potential side effects such as fluid in your legs or feet and muscle weakness, muscle twitches or a pounding heart beat (palpitations) which may be signs of low blood potassium (see Side Effects section below). Take the prednisone exactly as your doctor has told you.

Overdose

In case of drug overdose, contact a health care practitioner, hospital emergency department or regional Poison Control Centre immediately, even if there are no symptoms.

Missed dose:

If you forget to take ZYTIGA[®] or prednisone, take your normal dose the following day.

If you forget to take ZYTIGA[®] or prednisone for more than one day, talk to your doctor without delay.

SIDE EFFECTS AND WHAT TO DO ABOUT THEM

Like all medicines, ZYTIGA[®] can cause side effects, although not everybody gets them. The following side effects may happen with this medicine:

Very Common (affects more than 1 in 10 people):

- Joint swelling or pain, muscle pain
- Hot flushes
- Cough
- Diarrhea
- Fatigue
- Constipation
- Vomiting
- Insomnia
- Anemia
- High blood pressure

Common (affects less than 1 in 10 people):

- High fat levels in your blood
- Liver function test increases
- Heart failure
- Rapid or irregular heart rate associated with feeling faint or lightheaded
- Upper and lower respiratory infection
- Stomach upset / Indigestion
- Flu-like symptoms
- Weight increase
- Urinary frequency
- Bone break (fracture)
- Presence of blood in your urine
- Rash and skin lesions
- Falls
- Bruising
- Headache
- Depression

Uncommon (affects less than 1 in 100 people):

- Adrenal gland problems

Reported from post-marketing with unknown frequency

- Lung irritation - Symptoms may include shortness of breath, cough and fatigue.

If any of the side effects gets serious, or if you notice any side effects not listed in this leaflet, please tell your doctor or pharmacist.

Your blood pressure, serum potassium, signs and symptoms of fluid retention will be monitored clinically by your doctor.

SERIOUS SIDE EFFECTS, HOW OFTEN THEY HAPPEN AND WHAT TO DO ABOUT THEM

Symptom / effect	Talk with your doctor or pharmacist		Stop taking drug and call your doctor or pharmacist
	Only if severe	In all cases	
Very Common			
Muscle weakness, muscle twitches or a pounding heart beat (palpitations). These may be signs of low level of potassium in your blood.			✓
Swollen hands, legs, ankles or feet			✓
Burning on urination or cloudy urine (Urinary tract infection)		✓	
Common			
Chest pain		✓	
Irregular heartbeat (heart beat disorder) that can be associated with feeling faint, lightheaded, chest pain, a racing heartbeat, a slow heartbeat, shortness of breath, sweating, or a fluttering in your chest.		✓	
Rapid heart rate		✓	
Unknown			
Shortness of breath		✓	
Breakdown of muscle tissue and muscle weakness and/or muscle pain		✓	
Yellowing of the skin or eyes, darkening of the urine, or severe nausea or vomiting (Failure of the liver to function/ acute liver failure)		✓	

This is not a complete list of side effects. For any unexpected effects while taking ZYTIGA[®], contact your doctor or pharmacist.

HOW TO STORE IT

ZYTIGA[®] tablets should be stored at 15–30°C. Keep out of the reach and sight of children.

Do not use ZYTIGA[®] after the expiry date which is stated on the label. The expiry date refers to the last day of the month.

Medicines should not be thrown away via wastewater or household waste. Throw away any unused product or waste material in accordance with local requirements. If you are not sure, ask your pharmacist how to throw away medicines

no longer required. These measures will help to protect the environment.

REPORTING SIDE EFFECTS

You can report any suspected side effects associated with the use of health products to Health Canada by:

- Visiting the Web page on Adverse Reaction Reporting (www.canada.ca/en/health-canada/services/drugs-health-products/medeffect-canada/adverse-reaction-reporting) for more information on how to report online, by mail or by fax: or
- Calling toll-free at 1-866-234-2345

NOTE: Contact your health professional if you need information about how to manage your side effects. The Canada Vigilance Program does not provide medical advice.

MORE INFORMATION

For questions, concerns, or the full Product Monograph go to: www.janssen.com/canada or contact the manufacturer, Janssen Inc., at: 1-800-567-3331 or 1-800-387-8781.

This leaflet was prepared by Janssen Inc., Toronto, Ontario M3C 1L9

Last revised: September 22, 2020
All trademarks used under license.

HIGHLIGHTS OF PRESCRIBING INFORMATION

These highlights do not include all the information needed to use ZYTIGA safely and effectively. See full prescribing information for ZYTIGA.

ZYTIGA® (abiraterone acetate) tablets, for oral use
Initial U.S. Approval: 2011

RECENT MAJOR CHANGES

Warnings and Precautions (5.6) 10/2020

INDICATIONS AND USAGE

ZYTIGA is a CYP17 inhibitor indicated in combination with prednisone for the treatment of patients with

- metastatic castration-resistant prostate cancer (CRPC). (1)
- metastatic high-risk castration-sensitive prostate cancer (CSPC). (1)

DOSAGE AND ADMINISTRATION

Metastatic castration-resistant prostate cancer:

- ZYTIGA 1,000 mg orally once daily with prednisone 5 mg orally **twice** daily. (2.1)

Metastatic castration-sensitive prostate cancer:

- ZYTIGA 1,000 mg orally once daily with prednisone 5 mg orally **once** daily. (2.2)

Patients receiving ZYTIGA should also receive a gonadotropin-releasing hormone (GnRH) analog concurrently or should have had bilateral orchiectomy. ZYTIGA must be taken on an empty stomach with water at least 1 hour before or 2 hours after a meal. Do not crush or chew tablets. (2.3)

Dose Modification:

- For patients with baseline moderate hepatic impairment (Child-Pugh Class B), reduce the ZYTIGA starting dose to 250 mg once daily. (2.4)
- For patients who develop hepatotoxicity during treatment, hold ZYTIGA until recovery. Retreatment may be initiated at a reduced dose. ZYTIGA should be discontinued if patients develop severe hepatotoxicity. (2.4)

DOSAGE FORMS AND STRENGTHS

- Film-Coated Tablet 500 mg (3)
- Uncoated Tablet 250 mg (3)

CONTRAINDICATIONS

None

WARNINGS AND PRECAUTIONS

- Mineralocorticoid excess: Closely monitor patients with cardiovascular disease. Control hypertension and correct hypokalemia before treatment. Monitor blood pressure, serum potassium and symptoms of fluid retention at least monthly. (5.1)

- Adrenocortical insufficiency: Monitor for symptoms and signs of adrenocortical insufficiency. Increased dosage of corticosteroids may be indicated before, during and after stressful situations. (5.2)
- Hepatotoxicity: Can be severe and fatal. Monitor liver function and modify, interrupt, or discontinue ZYTIGA dosing as recommended. (5.3)
- Increased fractures and mortality in combination with radium Ra 223 dichloride: Use of ZYTIGA plus prednisone/prednisolone in combination with radium Ra 223 dichloride is not recommended. (5.4)
- Embryo-Fetal Toxicity: ZYTIGA can cause fetal harm. Advise males with female partners of reproductive potential to use effective contraception. (5.5, 8.1, 8.3)
- Hypoglycemia: Severe hypoglycemia has been reported in patients with pre-existing diabetes who are taking medications containing thiazolidinediones (including pioglitazone) or repaglinide. Monitor blood glucose in patients with diabetes and assess if antidiabetic agent dose modifications are required. (5.6)

ADVERSE REACTIONS

The most common adverse reactions (≥10%) are fatigue, arthralgia, hypertension, nausea, edema, hypokalemia, hot flush, diarrhea, vomiting, upper respiratory infection, cough, and headache. (6.1)

The most common laboratory abnormalities (>20%) are anemia, elevated alkaline phosphatase, hypertriglyceridemia, lymphopenia, hypercholesterolemia, hyperglycemia, and hypokalemia. (6.1)

To report SUSPECTED ADVERSE REACTIONS, contact Janssen Biotech, Inc. at 1-800-526-7736 (1-800-JANSSEN) or FDA at 1-800-FDA-1088 or www.fda.gov/medwatch.

DRUG INTERACTIONS

- CYP3A4 Inducers: Avoid concomitant strong CYP3A4 inducers during ZYTIGA treatment. If a strong CYP3A4 inducer must be co-administered, increase the ZYTIGA dosing frequency. (2.5, 7.1)
- CYP2D6 Substrates: Avoid co-administration of ZYTIGA with CYP2D6 substrates that have a narrow therapeutic index. If an alternative treatment cannot be used, exercise caution and consider a dose reduction of the concomitant CYP2D6 substrate. (7.2)

USE IN SPECIFIC POPULATIONS

- Do not use ZYTIGA in patients with baseline severe hepatic impairment (Child-Pugh Class C). (8.6)

See 17 for PATIENT COUNSELING INFORMATION and FDA-approved patient labeling.

Revised: 10/2020

FULL PRESCRIBING INFORMATION: CONTENTS*

1 INDICATIONS AND USAGE

2 DOSAGE AND ADMINISTRATION

- 2.1 Recommended Dose for Metastatic CRPC
- 2.2 Recommended Dose for Metastatic High-risk CSPC
- 2.3 Important Administration Instructions
- 2.4 Dose Modification Guidelines in Hepatic Impairment and Hepatotoxicity
- 2.5 Dose Modification Guidelines for Strong CYP3A4 Inducers

3 DOSAGE FORMS AND STRENGTHS

4 CONTRAINDICATIONS

5 WARNINGS AND PRECAUTIONS

- 5.1 Hypokalemia, Fluid Retention, and Cardiovascular Adverse Reactions due to Mineralocorticoid Excess
- 5.2 Adrenocortical Insufficiency
- 5.3 Hepatotoxicity
- 5.4 Increased Fractures and Mortality in Combination with Radium Ra 223 Dichloride
- 5.5 Embryo-Fetal Toxicity
- 5.6 Hypoglycemia

6 ADVERSE REACTIONS

- 6.1 Clinical Trial Experience
- 6.2 Postmarketing Experience

7 DRUG INTERACTIONS

- 7.1 Drugs that Inhibit or Induce CYP3A4 Enzymes

- 7.2 Effects of Abiraterone on Drug Metabolizing Enzymes

8 USE IN SPECIFIC POPULATIONS

- 8.1 Pregnancy
- 8.2 Lactation
- 8.3 Females and Males of Reproductive Potential
- 8.4 Pediatric Use
- 8.5 Geriatric Use
- 8.6 Patients with Hepatic Impairment
- 8.7 Patients with Renal Impairment

10 OVERDOSAGE

11 DESCRIPTION

12 CLINICAL PHARMACOLOGY

- 12.1 Mechanism of Action
- 12.2 Pharmacodynamics
- 12.3 Pharmacokinetics

13 NONCLINICAL TOXICOLOGY

- 13.1 Carcinogenesis, Mutagenesis, and Impairment of Fertility
- 13.2 Animal Toxicology and/or Pharmacology

14 CLINICAL STUDIES

16 HOW SUPPLIED/STORAGE AND HANDLING

17 PATIENT COUNSELING INFORMATION

*Sections or subsections omitted from the full prescribing information are not listed.

FULL PRESCRIBING INFORMATION

1 INDICATIONS AND USAGE

ZYTIGA is indicated in combination with prednisone for the treatment of patients with

- Metastatic castration-resistant prostate cancer (CRPC)
- Metastatic high-risk castration-sensitive prostate cancer (CSPC)

2 DOSAGE AND ADMINISTRATION

2.1 Recommended Dose for Metastatic CRPC

The recommended dose of ZYTIGA is 1,000 mg (two 500 mg tablets or four 250 mg tablets) orally once daily with prednisone 5 mg orally **twice** daily.

2.2 Recommended Dose for Metastatic High-risk CSPC

The recommended dose of ZYTIGA is 1,000 mg (two 500 mg tablets or four 250 mg tablets) orally once daily with prednisone 5 mg administered orally **once** daily.

2.3 Important Administration Instructions

Patients receiving ZYTIGA should also receive a gonadotropin-releasing hormone (GnRH) analog concurrently or should have had bilateral orchiectomy. ZYTIGA must be taken on an empty stomach, at least one hour before or at least two hours after a meal [*see Clinical Pharmacology (12.3)*]. The tablets should be swallowed whole with water. Do not crush or chew tablets.

2.4 Dose Modification Guidelines in Hepatic Impairment and Hepatotoxicity

Hepatic Impairment

In patients with baseline moderate hepatic impairment (Child-Pugh Class B), reduce the recommended dose of ZYTIGA to 250 mg once daily. In patients with moderate hepatic impairment monitor ALT, AST, and bilirubin prior to the start of treatment, every week for the first month, every two weeks for the following two months of treatment and monthly thereafter. If elevations in ALT and/or AST greater than 5X upper limit of normal (ULN) or total bilirubin greater than 3X ULN occur in patients with baseline moderate hepatic impairment, discontinue ZYTIGA and do not re-treat patients with ZYTIGA [*see Use in Specific Populations (8.6)* and *Clinical Pharmacology (12.3)*].

Do not use ZYTIGA in patients with baseline severe hepatic impairment (Child-Pugh Class C).

Hepatotoxicity

For patients who develop hepatotoxicity during treatment with ZYTIGA (ALT and/or AST greater than 5X ULN or total bilirubin greater than 3X ULN), interrupt treatment with ZYTIGA

[see *Warnings and Precautions (5.3)*]. Treatment may be restarted at a reduced dose of 750 mg once daily following return of liver function tests to the patient's baseline or to AST and ALT less than or equal to 2.5X ULN and total bilirubin less than or equal to 1.5X ULN. For patients who resume treatment, monitor serum transaminases and bilirubin at a minimum of every two weeks for three months and monthly thereafter.

If hepatotoxicity recurs at the dose of 750 mg once daily, re-treatment may be restarted at a reduced dose of 500 mg once daily following return of liver function tests to the patient's baseline or to AST and ALT less than or equal to 2.5X ULN and total bilirubin less than or equal to 1.5X ULN.

If hepatotoxicity recurs at the reduced dose of 500 mg once daily, discontinue treatment with ZYTIGA.

Permanently discontinue ZYTIGA for patients who develop a concurrent elevation of ALT greater than 3 x ULN and total bilirubin greater than 2 x ULN in the absence of biliary obstruction or other causes responsible for the concurrent elevation [see *Warnings and Precautions (5.3)*].

2.5 Dose Modification Guidelines for Strong CYP3A4 Inducers

Avoid concomitant strong CYP3A4 inducers (e.g., phenytoin, carbamazepine, rifampin, rifabutin, rifapentine, phenobarbital) during ZYTIGA treatment.

If a strong CYP3A4 inducer must be co-administered, increase the ZYTIGA dosing frequency to twice a day only during the co-administration period (e.g., from 1,000 mg once daily to 1,000 mg twice a day). Reduce the dose back to the previous dose and frequency, if the concomitant strong CYP3A4 inducer is discontinued [see *Drug Interactions (7.1)* and *Clinical Pharmacology (12.3)*].

3 DOSAGE FORMS AND STRENGTHS

Tablets (500 mg): purple, oval-shaped, film-coated tablets debossed with "AA" one side and "500" on the other side.

Tablets (250 mg): white to off-white, oval-shaped tablets debossed with "AA250" on one side.

4 CONTRAINDICATIONS

None.

5 WARNINGS AND PRECAUTIONS

5.1 Hypokalemia, Fluid Retention, and Cardiovascular Adverse Reactions due to Mineralocorticoid Excess

ZYTIGA may cause hypertension, hypokalemia, and fluid retention as a consequence of increased mineralocorticoid levels resulting from CYP17 inhibition [see *Clinical Pharmacology (12.1)*]. Monitor patients for hypertension, hypokalemia, and fluid retention at least once a month. Control hypertension and correct hypokalemia before and during treatment with ZYTIGA.

In the combined data from 4 placebo-controlled trials using prednisone 5 mg twice daily in combination with 1000 mg abiraterone acetate daily, grades 3-4 hypokalemia were detected in 4% of patients on the ZYTIGA arm and 2% of patients on the placebo arm. Grades 3-4 hypertension were observed in 2% of patients each arm and grades 3-4 fluid retention in 1% of patients each arm.

In LATITUDE (a randomized placebo-controlled, multicenter clinical trial), which used prednisone 5 mg daily in combination with 1000 mg abiraterone acetate daily, grades 3-4 hypokalemia were detected in 10% of patients on the ZYTIGA arm and 1% of patients on the placebo arm, grades 3-4 hypertension were observed in 20% of patients on the ZYTIGA arm and 10% of patients on the placebo arm. Grades 3-4 fluid retention occurred in 1% of patients each arm [see *Adverse Reactions (6)*].

Closely monitor patients whose underlying medical conditions might be compromised by increases in blood pressure, hypokalemia or fluid retention, such as those with heart failure, recent myocardial infarction, cardiovascular disease, or ventricular arrhythmia. In postmarketing experience, QT prolongation and Torsades de Pointes have been observed in patients who develop hypokalemia while taking ZYTIGA.

The safety of ZYTIGA in patients with left ventricular ejection fraction <50% or New York Heart Association (NYHA) Class III or IV heart failure (in COU-AA-301) or NYHA Class II to IV heart failure (in COU-AA-302 and LATITUDE) has not been established because these patients were excluded from these randomized clinical trials [see *Clinical Studies (14)*].

5.2 Adrenocortical Insufficiency

Adrenal insufficiency occurred in 0.3% of 2230 patients taking ZYTIGA and in 0.1% of 1763 patients taking placebo in the combined data of the 5 randomized, placebo-controlled clinical studies. Adrenocortical insufficiency was reported in patients receiving ZYTIGA in combination with prednisone, following interruption of daily steroids and/or with concurrent infection or stress.

Monitor patients for symptoms and signs of adrenocortical insufficiency, particularly if patients are withdrawn from prednisone, have prednisone dose reductions, or experience unusual stress. Symptoms and signs of adrenocortical insufficiency may be masked by adverse reactions associated with mineralocorticoid excess seen in patients treated with ZYTIGA. If clinically indicated, perform appropriate tests to confirm the diagnosis of adrenocortical insufficiency. Increased dosage of corticosteroids may be indicated before, during and after stressful situations [*see Warnings and Precautions (5.1)*].

5.3 Hepatotoxicity

In postmarketing experience, there have been ZYTIGA-associated severe hepatic toxicity, including fulminant hepatitis, acute liver failure and deaths [*see Adverse Reactions (6.2)*].

In the combined data of 5 randomized clinical trials, grade 3-4 ALT or AST increases (at least 5X ULN) were reported in 6% of 2230 patients who received ZYTIGA, typically during the first 3 months after starting treatment. Patients whose baseline ALT or AST were elevated were more likely to experience liver test elevation than those beginning with normal values. Treatment discontinuation due to ALT and AST increases or abnormal hepatic function occurred in 1.1% of 2230 patients taking ZYTIGA. In these clinical trials, no deaths clearly related to ZYTIGA were reported due to hepatotoxicity events.

Measure serum transaminases (ALT and AST) and bilirubin levels prior to starting treatment with ZYTIGA, every two weeks for the first three months of treatment and monthly thereafter. In patients with baseline moderate hepatic impairment receiving a reduced ZYTIGA dose of 250 mg, measure ALT, AST, and bilirubin prior to the start of treatment, every week for the first month, every two weeks for the following two months of treatment and monthly thereafter. Promptly measure serum total bilirubin, AST, and ALT if clinical symptoms or signs suggestive of hepatotoxicity develop. Elevations of AST, ALT, or bilirubin from the patient's baseline should prompt more frequent monitoring. If at any time AST or ALT rise above five times the ULN, or the bilirubin rises above three times the ULN, interrupt ZYTIGA treatment and closely monitor liver function.

Re-treatment with ZYTIGA at a reduced dose level may take place only after return of liver function tests to the patient's baseline or to AST and ALT less than or equal to 2.5X ULN and total bilirubin less than or equal to 1.5X ULN [*see Dosage and Administration (2.4)*].

Permanently discontinue ZYTIGA for patients who develop a concurrent elevation of ALT greater than 3 x ULN and total bilirubin greater than 2 x ULN in the absence of biliary obstruction or other causes responsible for the concurrent elevation [*see Dosage and Administration (2.4)*].

The safety of ZYTIGA re-treatment of patients who develop AST or ALT greater than or equal to 20X ULN and/or bilirubin greater than or equal to 10X ULN is unknown.

5.4 Increased Fractures and Mortality in Combination with Radium Ra 223 Dichloride

ZYTIGA plus prednisone/prednisolone is not recommended for use in combination with radium Ra 223 dichloride outside of clinical trials.

The clinical efficacy and safety of concurrent initiation of ZYTIGA plus prednisone/prednisolone and radium Ra 223 dichloride was assessed in a randomized, placebo-controlled multicenter study (ERA-223 trial) in 806 patients with asymptomatic or mildly symptomatic castration-resistant prostate cancer with bone metastases. The study was unblinded early based on an Independent Data Monitoring Committee recommendation.

At the primary analysis, increased incidences of fractures (28.6% vs 11.4%) and deaths (38.5% vs 35.5%) have been observed in patients who received ZYTIGA plus prednisone/prednisolone in combination with radium Ra 223 dichloride compared to patients who received placebo in combination with ZYTIGA plus prednisone/prednisolone.

5.5 Embryo-Fetal Toxicity

The safety and efficacy of ZYTIGA have not been established in females. Based on animal reproductive studies and mechanism of action, ZYTIGA can cause fetal harm and loss of pregnancy when administered to a pregnant female. In animal reproduction studies, oral administration of abiraterone acetate to pregnant rats during organogenesis caused adverse developmental effects at maternal exposures approximately ≥ 0.03 times the human exposure (AUC) at the recommended dose. Advise males with female partners of reproductive potential to use effective contraception during treatment with ZYTIGA and for 3 weeks after the last dose of ZYTIGA [see *Use in Specific Populations (8.1, 8.3)*]. ZYTIGA should not be handled by females who are or may become pregnant [see *How Supplied/Storage and Handling (16)*].

5.6 Hypoglycemia

Severe hypoglycemia has been reported when ZYTIGA was administered to patients with pre-existing diabetes receiving medications containing thiazolidinediones (including pioglitazone) or repaglinide [see *Drug Interactions (7.2)*]. Monitor blood glucose in patients with diabetes during and after discontinuation of treatment with ZYTIGA. Assess if antidiabetic drug dosage needs to be adjusted to minimize the risk of hypoglycemia.

6 ADVERSE REACTIONS

The following are discussed in more detail in other sections of the labeling:

- Hypokalemia, Fluid Retention, and Cardiovascular Adverse Reactions due to Mineralocorticoid Excess [*see Warnings and Precautions (5.1)*].
- Adrenocortical Insufficiency [*see Warnings and Precautions (5.2)*].
- Hepatotoxicity [*see Warnings and Precautions (5.3)*].
- Increased Fractures and Mortality in Combination with Radium Ra 223 Dichloride [*see Warnings and Precautions (5.4)*].

6.1 Clinical Trial Experience

Because clinical trials are conducted under widely varying conditions, adverse reaction rates observed in the clinical trials of a drug cannot be directly compared to rates in the clinical trials of another drug and may not reflect the rates observed in clinical practice.

Two randomized placebo-controlled, multicenter clinical trials (COU-AA-301 and COU-AA-302) enrolled patients who had metastatic CRPC in which ZYTIGA was administered orally at a dose of 1,000 mg daily in combination with prednisone 5 mg twice daily in the active treatment arms. Placebo plus prednisone 5 mg twice daily was given to patients on the control arm. A third randomized placebo-controlled, multicenter clinical trial (LATITUDE) enrolled patients who had metastatic high-risk CSPC in which ZYTIGA was administered at a dose of 1,000 mg daily in combination with prednisone 5 mg once daily. Placebos were administered to patients in the control arm. Additionally, two other randomized, placebo-controlled trials were conducted in patients with metastatic CRPC. The safety data pooled from 2230 patients in the 5 randomized controlled trials constitute the basis for the data presented in the Warnings and Precautions, Grade 1-4 adverse reactions, and Grade 1-4 laboratory abnormalities. In all trials, a gonadotropin-releasing hormone (GnRH) analog or prior orchiectomy was required in both arms.

In the pooled data, median treatment duration was 11 months (0.1, 43) for ZYTIGA-treated patients and 7.2 months (0.1, 43) for placebo-treated patients. The most common adverse reactions ($\geq 10\%$) that occurred more commonly ($>2\%$) in the ZYTIGA arm were fatigue, arthralgia, hypertension, nausea, edema, hypokalemia, hot flush, diarrhea, vomiting, upper respiratory infection, cough, and headache. The most common laboratory abnormalities ($>20\%$) that occurred more commonly ($\geq 2\%$) in the ZYTIGA arm were anemia, elevated alkaline phosphatase, hypertriglyceridemia, lymphopenia, hypercholesterolemia, hyperglycemia, and hypokalemia. Grades 3-4 adverse events were reported for 53% of patients in the ZYTIGA arm and 46% of patients in the placebo arm. Treatment discontinuation was reported in 14% of patients in the ZYTIGA arm and 13% of patients in the placebo arm. The common adverse

events ($\geq 1\%$) resulting in discontinuation of ZYTIGA and prednisone were hepatotoxicity and cardiac disorders.

Deaths associated with treatment-emergent adverse events were reported for 7.5% of patients in the ZYTIGA arm and 6.6% of patients in the placebo arm. Of the patients in the ZYTIGA arm, the most common cause of death was disease progression (3.3%). Other reported causes of death in ≥ 5 patients included pneumonia, cardio-respiratory arrest, death (no additional information), and general physical health deterioration.

COU-AA-301: Metastatic CRPC Following Chemotherapy

COU-AA-301 enrolled 1195 patients with metastatic CRPC who had received prior docetaxel chemotherapy. Patients were not eligible if AST and/or ALT ≥ 2.5 X ULN in the absence of liver metastases. Patients with liver metastases were excluded if AST and/or ALT >5 X ULN.

Table 1 shows adverse reactions on the ZYTIGA arm in COU-AA-301 that occurred with a $\geq 2\%$ absolute increase in frequency compared to placebo or were events of special interest. The median duration of treatment with ZYTIGA with prednisone was 8 months.

Table 1: Adverse Reactions due to ZYTIGA in COU-AA-301

System/Organ Class Adverse reaction	ZYTIGA with Prednisone (N=791)		Placebo with Prednisone (N=394)	
	All Grades ¹ %	Grade 3-4 %	All Grades %	Grade 3-4 %
Musculoskeletal and connective tissue disorders				
Joint swelling/discomfort ²	30	4.2	23	4.1
Muscle discomfort ³	26	3.0	23	2.3
General disorders				
Edema ⁴	27	1.9	18	0.8
Vascular disorders				
Hot flush	19	0.3	17	0.3
Hypertension	8.5	1.3	6.9	0.3
Gastrointestinal disorders				
Diarrhea	18	0.6	14	1.3
Dyspepsia	6.1	0	3.3	0
Infections and infestations				
Urinary tract infection	12	2.1	7.1	0.5
Upper respiratory tract infection	5.4	0	2.5	0
Respiratory, thoracic and mediastinal disorders				
Cough	11	0	7.6	0
Renal and urinary disorders				
Urinary frequency	7.2	0.3	5.1	0.3
Nocturia	6.2	0	4.1	0
Injury, poisoning and procedural complications				
Fractures ⁵	5.9	1.4	2.3	0

Cardiac disorders

Arrhythmia ⁶	7.2	1.1	4.6	1.0
Chest pain or chest discomfort ⁷	3.8	0.5	2.8	0
Cardiac failure ⁸	2.3	1.9	1.0	0.3

¹ Adverse events graded according to CTCAE version 3.0.

² Includes terms Arthritis, Arthralgia, Joint swelling, and Joint stiffness.

³ Includes terms Muscle spasms, Musculoskeletal pain, Myalgia, Musculoskeletal discomfort, and Musculoskeletal stiffness.

⁴ Includes terms Edema, Edema peripheral, Pitting edema, and Generalized edema.

⁵ Includes all fractures with the exception of pathological fracture.

⁶ Includes terms Arrhythmia, Tachycardia, Atrial fibrillation, Supraventricular tachycardia, Atrial tachycardia, Ventricular tachycardia, Atrial flutter, Bradycardia, Atrioventricular block complete, Conduction disorder, and Bradyarrhythmia.

⁷ Includes terms Angina pectoris, Chest pain, and Angina unstable. Myocardial infarction or ischemia occurred more commonly in the placebo arm than in the ZYTIGA arm (1.3% vs. 1.1% respectively).

⁸ Includes terms Cardiac failure, Cardiac failure congestive, Left ventricular dysfunction, Cardiogenic shock, Cardiomegaly, Cardiomyopathy, and Ejection fraction decreased.

Table 2 shows laboratory abnormalities of interest from COU-AA-301.

Table 2: Laboratory Abnormalities of Interest in COU-AA-301

Laboratory Abnormality	ZYTIGA with Prednisone (N=791)		Placebo with Prednisone (N=394)	
	All Grades (%)	Grade 3-4 (%)	All Grades (%)	Grade 3-4 (%)
Hypertriglyceridemia	63	0.4	53	0
High AST	31	2.1	36	1.5
Hypokalemia	28	5.3	20	1.0
Hypophosphatemia	24	7.2	16	5.8
High ALT	11	1.4	10	0.8
High Total Bilirubin	6.6	0.1	4.6	0

COU-AA-302: Metastatic CRPC Prior to Chemotherapy

COU-AA-302 enrolled 1088 patients with metastatic CRPC who had not received prior cytotoxic chemotherapy. Patients were ineligible if AST and/or ALT $\geq 2.5X$ ULN and patients were excluded if they had liver metastases.

Table 3 shows adverse reactions on the ZYTIGA arm in COU-AA-302 that occurred in $\geq 5\%$ of patients with a $\geq 2\%$ absolute increase in frequency compared to placebo. The median duration of treatment with ZYTIGA with prednisone was 13.8 months.

Table 3: Adverse Reactions in $\geq 5\%$ of Patients on the ZYTIGA Arm in COU-AA-302

System/Organ Class Adverse reaction	ZYTIGA with Prednisone (N=542)		Placebo with Prednisone (N=540)	
	All Grades ¹ %	Grade 3-4 %	All Grades %	Grade 3-4 %
General disorders				
Fatigue	39	2.2	34	1.7
Edema ²	25	0.4	21	1.1
Pyrexia	8.7	0.6	5.9	0.2
Musculoskeletal and connective tissue disorders				
Joint swelling/discomfort ³	30	2.0	25	2.0
Groin pain	6.6	0.4	4.1	0.7
Gastrointestinal disorders				
Constipation	23	0.4	19	0.6
Diarrhea	22	0.9	18	0.9
Dyspepsia	11	0.0	5.0	0.2
Vascular disorders				
Hot flush	22	0.2	18	0.0
Hypertension	22	3.9	13	3.0
Respiratory, thoracic and mediastinal disorders				
Cough	17	0.0	14	0.2
Dyspnea	12	2.4	9.6	0.9
Psychiatric disorders				
Insomnia	14	0.2	11	0.0
Injury, poisoning and procedural complications				
Contusion	13	0.0	9.1	0.0
Falls	5.9	0.0	3.3	0.0
Infections and infestations				
Upper respiratory tract infection	13	0.0	8.0	0.0
Nasopharyngitis	11	0.0	8.1	0.0
Renal and urinary disorders				
Hematuria	10	1.3	5.6	0.6
Skin and subcutaneous tissue disorders				
Rash	8.1	0.0	3.7	0.0

¹ Adverse events graded according to CTCAE version 3.0.

² Includes terms Edema peripheral, Pitting edema, and Generalized edema.

³ Includes terms Arthritis, Arthralgia, Joint swelling, and Joint stiffness.

Table 4 shows laboratory abnormalities that occurred in greater than 15% of patients, and more frequently ($>5\%$) in the ZYTIGA arm compared to placebo in COU-AA-302.

Table 4: Laboratory Abnormalities in $>15\%$ of Patients in the ZYTIGA Arm of COU-AA-302

Laboratory Abnormality	ZYTIGA with Prednisone (N=542)		Placebo with Prednisone (N=540)	
	Grade 1-4 %	Grade 3-4 %	Grade 1-4 %	Grade 3-4 %
Hematology				
Lymphopenia	38	8.7	32	7.4

Chemistry				
Hyperglycemia ¹	57	6.5	51	5.2
High ALT	42	6.1	29	0.7
High AST	37	3.1	29	1.1
Hypnatremia	33	0.4	25	0.2
Hypokalemia	17	2.8	10	1.7

¹ Based on non-fasting blood draws

LATITUDE: Patients with Metastatic High-risk CSPC

LATITUDE enrolled 1199 patients with newly-diagnosed metastatic, high-risk CSPC who had not received prior cytotoxic chemotherapy. Patients were ineligible if AST and/or ALT $\geq 2.5X$ ULN or if they had liver metastases. All the patients received GnRH analogs or had prior bilateral orchiectomy during the trial. The median duration of treatment with ZYTIGA and prednisone was 24 months.

Table 5 shows adverse reactions on the ZYTIGA arm that occurred in $\geq 5\%$ of patients with a $\geq 2\%$ absolute increase in frequency compared to those on the placebos arm.

Table 5: Adverse Reactions in $\geq 5\%$ of Patients on the ZYTIGA Arm in LATITUDE¹

System/Organ Class Adverse reaction	ZYTIGA with Prednisone (N=597)		Placebos (N=602)	
	All Grades ² %	Grade 3-4 %	All Grades %	Grade 3-4 %
Vascular disorders				
Hypertension	37	20	13	10
Hot flush	15	0.0	13	0.2
Metabolism and nutrition disorders				
Hypokalemia	20	10	3.7	1.3
Investigations				
Alanine aminotransferase increased ³	16	5.5	13	1.3
Aspartate aminotransferase increased ³	15	4.4	11	1.5
Infections and infestations				
Urinary tract infection	7.0	1.0	3.7	0.8
Upper respiratory tract infection	6.7	0.2	4.7	0.2
Nervous system disorders				
Headache	7.5	0.3	5.0	0.2
Respiratory, Thoracic and Mediastinal Disorders				
Cough ⁴	6.5	0.0	3.2	0

¹ All patients were receiving an GnRH agonist or had undergone orchiectomy.

² Adverse events graded according to CTCAE version 4.0

³ Reported as an adverse event or reaction

⁴ Including cough, productive cough, upper airway cough syndrome

Table 6 shows laboratory abnormalities that occurred in >15% of patients, and more frequently (>5%) in the ZYTIGA arm compared to placebos.

Table 6: Laboratory Abnormalities in >15% of Patients in the ZYTIGA Arm of LATITUDE

Laboratory Abnormality	ZYTIGA with Prednisone (N=597)		Placebos (N=602)	
	Grade 1-4 %	Grade 3-4 %	Grade 1-4 %	Grade 3-4 %
Hematology				
Lymphopenia	20	4.1	14	1.8
Chemistry				
Hypokalemia	30	9.6	6.7	1.3
Elevated ALT	46	6.4	45	1.3
Elevated total bilirubin	16	0.2	6.2	0.2

Cardiovascular Adverse Reactions

In the combined data of 5 randomized, placebo-controlled clinical studies, cardiac failure occurred more commonly in patients on the ZYTIGA arm compared to patients on the placebo arm (2.6% versus 0.9%). Grade 3-4 cardiac failure occurred in 1.3% of patients taking ZYTIGA and led to 5 treatment discontinuations and 4 deaths. Grade 3-4 cardiac failure occurred in 0.2% of patients taking placebo. There were no treatment discontinuations and two deaths due to cardiac failure in the placebo group.

In the same combined data, the majority of arrhythmias were grade 1 or 2. There was one death associated with arrhythmia and three patients with sudden death in the ZYTIGA arms and five deaths in the placebo arms. There were 7 (0.3%) deaths due to cardiorespiratory arrest in the ZYTIGA arms and 2 (0.1%) deaths in the placebo arms. Myocardial ischemia or myocardial infarction led to death in 3 patients in the placebo arms and 3 deaths in the ZYTIGA arms.

6.2 Postmarketing Experience

The following additional adverse reactions have been identified during post approval use of ZYTIGA with prednisone. Because these reactions are reported voluntarily from a population of uncertain size, it is not always possible to reliably estimate their frequency or establish a causal relationship to drug exposure.

Respiratory, Thoracic and Mediastinal Disorders: non-infectious pneumonitis.

Musculoskeletal and Connective Tissue Disorders: myopathy, including rhabdomyolysis.

Hepatobiliary Disorders: fulminant hepatitis, including acute hepatic failure and death.

Cardiac Disorders: QT prolongation and Torsades de Pointes (observed in patients who developed hypokalemia or had underlying cardiovascular conditions).

Immune System Disorders – Hypersensitivity: anaphylactic reactions (severe allergic reactions that include, but are not limited to difficulty swallowing or breathing, swollen face, lips, tongue or throat, or an itchy rash (urticaria)).

7 DRUG INTERACTIONS

7.1 Drugs that Inhibit or Induce CYP3A4 Enzymes

Based on *in vitro* data, ZYTIGA is a substrate of CYP3A4.

In a dedicated drug interaction trial, co-administration of rifampin, a strong CYP3A4 inducer, decreased exposure of abiraterone by 55%. Avoid concomitant strong CYP3A4 inducers during ZYTIGA treatment. If a strong CYP3A4 inducer must be co-administered, increase the ZYTIGA dosing frequency [see *Dosage and Administration (2.5)* and *Clinical Pharmacology (12.3)*].

In a dedicated drug interaction trial, co-administration of ketoconazole, a strong inhibitor of CYP3A4, had no clinically meaningful effect on the pharmacokinetics of abiraterone [see *Clinical Pharmacology (12.3)*].

7.2 Effects of Abiraterone on Drug Metabolizing Enzymes

ZYTIGA is an inhibitor of the hepatic drug-metabolizing enzymes CYP2D6 and CYP2C8. In a CYP2D6 drug-drug interaction trial, the C_{max} and AUC of dextromethorphan (CYP2D6 substrate) were increased 2.8- and 2.9-fold, respectively, when dextromethorphan was given with abiraterone acetate 1,000 mg daily and prednisone 5 mg twice daily. Avoid co-administration of abiraterone acetate with substrates of CYP2D6 with a narrow therapeutic index (e.g., thioridazine). If alternative treatments cannot be used, consider a dose reduction of the concomitant CYP2D6 substrate drug [see *Clinical Pharmacology (12.3)*].

In a CYP2C8 drug-drug interaction trial in healthy subjects, the AUC of pioglitazone (CYP2C8 substrate) was increased by 46% when pioglitazone was given together with a single dose of 1,000 mg abiraterone acetate. Therefore, patients should be monitored closely for signs of toxicity related to a CYP2C8 substrate with a narrow therapeutic index if used concomitantly with ZYTIGA [see *Clinical Pharmacology (12.3)* and *Warnings and Precautions (5.6)*].

8 USE IN SPECIFIC POPULATIONS

8.1 Pregnancy

Risk Summary

The safety and efficacy of ZYTIGA have not been established in females. Based on findings from animal studies and the mechanism of action, ZYTIGA can cause fetal harm and potential loss of pregnancy.

There are no human data on the use of ZYTIGA in pregnant women. In animal reproduction studies, oral administration of abiraterone acetate to pregnant rats during organogenesis caused adverse developmental effects at maternal exposures approximately ≥ 0.03 times the human exposure (AUC) at the recommended dose (*see Data*).

Data

Animal Data

In an embryo-fetal developmental toxicity study in rats, abiraterone acetate caused developmental toxicity when administered at oral doses of 10, 30 or 100 mg/kg/day throughout the period of organogenesis (gestational days 6-17). Findings included embryo-fetal lethality (increased post implantation loss and resorptions and decreased number of live fetuses), fetal developmental delay (skeletal effects) and urogenital effects (bilateral ureter dilation) at doses ≥ 10 mg/kg/day, decreased fetal ano-genital distance at ≥ 30 mg/kg/day, and decreased fetal body weight at 100 mg/kg/day. Doses ≥ 10 mg/kg/day caused maternal toxicity. The doses tested in rats resulted in systemic exposures (AUC) approximately 0.03, 0.1 and 0.3 times, respectively, the AUC in patients.

8.2 Lactation

Risk Summary

The safety and efficacy of ZYTIGA have not been established in females. There is no information available on the presence of abiraterone acetate in human milk, or on the effects on the breastfed child or milk production.

8.3 Females and Males of Reproductive Potential

Contraception

Males

Based on findings in animal reproduction studies and its mechanism of action, advise males with female partners of reproductive potential to use effective contraception during treatment and for 3 weeks after the final dose of ZYTIGA [*see Use in Specific Populations (8.1)*].

Infertility

Based on animal studies, ZYTIGA may impair reproductive function and fertility in males of reproductive potential [*see Nonclinical Toxicology (13.1)*].

8.4 Pediatric Use

Safety and effectiveness of ZYTIGA in pediatric patients have not been established.

8.5 Geriatric Use

Of the total number of patients receiving ZYTIGA in randomized clinical trials, 70% of patients were 65 years and over and 27% were 75 years and over. No overall differences in safety or effectiveness were observed between these elderly patients and younger patients. Other reported clinical experience has not identified differences in responses between the elderly and younger patients, but greater sensitivity of some older individuals cannot be ruled out.

8.6 Patients with Hepatic Impairment

The pharmacokinetics of abiraterone were examined in subjects with baseline mild (N=8) or moderate (N=8) hepatic impairment (Child-Pugh Class A and B, respectively) and in 8 healthy control subjects with normal hepatic function. The systemic exposure (AUC) of abiraterone after a single oral 1,000 mg dose of ZYTIGA increased by approximately 1.1-fold and 3.6-fold in subjects with mild and moderate baseline hepatic impairment, respectively compared to subjects with normal hepatic function.

In another trial, the pharmacokinetics of abiraterone were examined in subjects with baseline severe (N=8) hepatic impairment (Child-Pugh Class C) and in 8 healthy control subjects with normal hepatic function. The systemic exposure (AUC) of abiraterone increased by approximately 7-fold and the fraction of free drug increased 2-fold in subjects with severe baseline hepatic impairment compared to subjects with normal hepatic function.

No dosage adjustment is necessary for patients with baseline mild hepatic impairment. In patients with baseline moderate hepatic impairment (Child-Pugh Class B), reduce the recommended dose of ZYTIGA to 250 mg once daily. Do not use ZYTIGA in patients with baseline severe hepatic impairment (Child-Pugh Class C). If elevations in ALT or AST >5X ULN or total bilirubin >3X ULN occur in patients with baseline moderate hepatic impairment, discontinue ZYTIGA treatment [*see Dosage and Administration (2.4) and Clinical Pharmacology (12.3)*].

For patients who develop hepatotoxicity during treatment, interruption of treatment and dosage adjustment may be required [*see Dosage and Administration (2.4), Warnings and Precautions (5.3), and Clinical Pharmacology (12.3)*].

8.7 Patients with Renal Impairment

No dosage adjustment is necessary for patients with renal impairment [*see Clinical Pharmacology (12.3)*].

10 OVERDOSAGE

Human experience of overdose with ZYTIGA is limited.

There is no specific antidote. In the event of an overdose, stop ZYTIGA, undertake general supportive measures, including monitoring for arrhythmias and cardiac failure and assess liver function.

11 DESCRIPTION

Abiraterone acetate, the active ingredient of ZYTIGA is the acetyl ester of abiraterone. Abiraterone is an inhibitor of CYP17 (17 α -hydroxylase/C17,20-lyase). Each ZYTIGA tablet contains either 250 mg or 500 mg of abiraterone acetate. Abiraterone acetate is designated chemically as (3 β)-17-(3-pyridinyl) androsta-5,16-dien-3-yl acetate and its structure is:

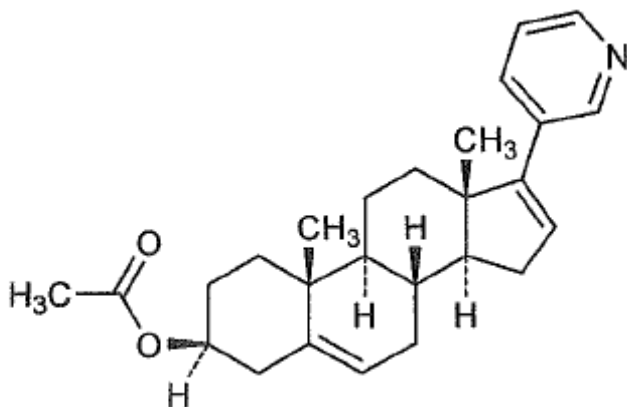

Abiraterone acetate is a white to off-white, non-hygroscopic, crystalline powder. Its molecular formula is C₂₆H₃₃NO₂ and it has a molecular weight of 391.55. Abiraterone acetate is a lipophilic compound with an octanol-water partition coefficient of 5.12 (Log P) and is practically insoluble in water. The pK_a of the aromatic nitrogen is 5.19.

ZYTIGA tablets are available in 500 mg film-coated tablets and 250 mg uncoated tablets with the following inactive ingredients:

- 500 mg film-coated tablets: colloidal silicon dioxide, croscarmellose sodium, hypromellose, lactose monohydrate, magnesium stearate, silicified microcrystalline cellulose, and sodium lauryl sulfate. The coating, Opadry[®] II Purple, contains iron oxide black, iron oxide red, polyethylene glycol, polyvinyl alcohol, talc, and titanium dioxide.
- 250 mg uncoated tablets: colloidal silicon dioxide, croscarmellose sodium, lactose monohydrate, magnesium stearate, microcrystalline cellulose, povidone, and sodium lauryl sulfate.

12 CLINICAL PHARMACOLOGY

12.1 Mechanism of Action

Abiraterone acetate (ZYTIGA) is converted *in vivo* to abiraterone, an androgen biosynthesis inhibitor, that inhibits 17 α -hydroxylase/C17,20-lyase (CYP17). This enzyme is expressed in testicular, adrenal, and prostatic tumor tissues and is required for androgen biosynthesis.

CYP17 catalyzes two sequential reactions: 1) the conversion of pregnenolone and progesterone to their 17 α -hydroxy derivatives by 17 α -hydroxylase activity and 2) the subsequent formation of dehydroepiandrosterone (DHEA) and androstenedione, respectively, by C17, 20-lyase activity. DHEA and androstenedione are androgens and are precursors of testosterone. Inhibition of CYP17 by abiraterone can also result in increased mineralocorticoid production by the adrenals [*see Warnings and Precautions (5.1)*].

Androgen sensitive prostatic carcinoma responds to treatment that decreases androgen levels. Androgen deprivation therapies, such as treatment with GnRH agonists or orchiectomy, decrease androgen production in the testes but do not affect androgen production by the adrenals or in the tumor.

ZYTIGA decreased serum testosterone and other androgens in patients in the placebo-controlled clinical trial. It is not necessary to monitor the effect of ZYTIGA on serum testosterone levels.

Changes in serum prostate specific antigen (PSA) levels may be observed but have not been shown to correlate with clinical benefit in individual patients.

12.2 Pharmacodynamics

Cardiac Electrophysiology

In a multi-center, open-label, single-arm trial, 33 patients with metastatic CRPC received ZYTIGA orally at a dose of 1,000 mg once daily at least 1 hour before or 2 hours after a meal in combination with prednisone 5 mg orally twice daily. Assessments up to Cycle 2 Day 2 showed no large changes in the QTc interval (i.e., >20 ms) from baseline. However, small increases in the QTc interval (i.e., <10 ms) due to abiraterone acetate cannot be excluded due to study design limitations.

12.3 Pharmacokinetics

Following administration of abiraterone acetate, the pharmacokinetics of abiraterone and abiraterone acetate have been studied in healthy subjects and in patients with metastatic CRPC. *In vivo*, abiraterone acetate is converted to abiraterone. In clinical studies, abiraterone acetate plasma concentrations were below detectable levels (<0.2 ng/mL) in >99% of the analyzed samples.

Absorption

Following oral administration of abiraterone acetate to patients with metastatic CRPC, the median time to reach maximum plasma abiraterone concentrations is 2 hours. Abiraterone accumulation is observed at steady-state, with a 2-fold higher exposure (steady-state AUC) compared to a single 1,000 mg dose of abiraterone acetate.

At the dose of 1,000 mg daily in patients with metastatic CRPC, steady-state values (mean \pm SD) of C_{\max} were 226 ± 178 ng/mL and of AUC were 993 ± 639 ng.hr/mL. No major deviation from dose proportionality was observed in the dose range of 250 mg to 1,000 mg. However, the exposure was not significantly increased when the dose was doubled from 1,000 to 2,000 mg (8% increase in the mean AUC).

Systemic exposure of abiraterone is increased when abiraterone acetate is administered with food. In healthy subjects abiraterone C_{\max} and $AUC_{0-\infty}$ were approximately 7- and 5-fold higher, respectively, when a single dose of abiraterone acetate was administered with a low-fat meal (7% fat, 300 calories) and approximately 17- and 10-fold higher, respectively, when a single dose of abiraterone acetate was administered with a high-fat (57% fat, 825 calories) meal compared to overnight fasting. Abiraterone $AUC_{0-\infty}$ was approximately 7-fold or 1.6-fold higher, respectively, when a single dose of abiraterone acetate was administered 2 hours after or 1 hour before a medium fat meal (25% fat, 491 calories) compared to overnight fasting.

Systemic exposures of abiraterone in patients with metastatic CRPC, after repeated dosing of abiraterone acetate were similar when abiraterone acetate was taken with low-fat meals for 7 days and increased approximately 2-fold when taken with high-fat meals for 7 days compared to when taken at least 2 hours after a meal and at least 1 hour before a meal for 7 days.

Given the normal variation in the content and composition of meals, taking ZYTIGA with meals has the potential to result in increased and highly variable exposures. Therefore, ZYTIGA must be taken on an empty stomach, at least one hour before or at least two hours after a meal. The tablets should be swallowed whole with water [*see Dosage and Administration (2.3)*].

Distribution and Protein Binding

Abiraterone is highly bound (>99%) to the human plasma proteins, albumin and alpha-1 acid glycoprotein. The apparent steady-state volume of distribution (mean \pm SD) is $19,669 \pm 13,358$ L. *In vitro* studies show that at clinically relevant concentrations, abiraterone acetate and abiraterone are not substrates of P-glycoprotein (P-gp) and that abiraterone acetate is an inhibitor of P-gp.

Metabolism

Following oral administration of ¹⁴C-abiraterone acetate as capsules, abiraterone acetate is hydrolyzed to abiraterone (active metabolite). The conversion is likely through esterase activity (the esterases have not been identified) and is not CYP mediated. The two main circulating metabolites of abiraterone in human plasma are abiraterone sulphate (inactive) and N-oxide abiraterone sulphate (inactive), which account for about 43% of exposure each. CYP3A4 and SULT2A1 are the enzymes involved in the formation of N-oxide abiraterone sulphate and SULT2A1 is involved in the formation of abiraterone sulphate.

Excretion

In patients with metastatic CRPC, the mean terminal half-life of abiraterone in plasma (mean ± SD) is 12 ± 5 hours. Following oral administration of ¹⁴C-abiraterone acetate, approximately 88% of the radioactive dose is recovered in feces and approximately 5% in urine. The major compounds present in feces are unchanged abiraterone acetate and abiraterone (approximately 55% and 22% of the administered dose, respectively).

Patients with Hepatic Impairment

The pharmacokinetics of abiraterone was examined in subjects with baseline mild (N=8) or moderate (N=8) hepatic impairment (Child-Pugh Class A and B, respectively) and in 8 healthy control subjects with normal hepatic function. Systemic exposure to abiraterone after a single oral 1,000 mg dose given under fasting conditions increased approximately 1.1-fold and 3.6-fold in subjects with mild and moderate baseline hepatic impairment, respectively. The mean half-life of abiraterone is prolonged to approximately 18 hours in subjects with mild hepatic impairment and to approximately 19 hours in subjects with moderate hepatic impairment.

In another trial, the pharmacokinetics of abiraterone were examined in subjects with baseline severe (N=8) hepatic impairment (Child-Pugh Class C) and in 8 healthy control subjects with normal hepatic function. The systemic exposure (AUC) of abiraterone increased by approximately 7-fold in subjects with severe baseline hepatic impairment compared to subjects with normal hepatic function. In addition, the mean protein binding was found to be lower in the severe hepatic impairment group compared to the normal hepatic function group, which resulted in a two-fold increase in the fraction of free drug in patients with severe hepatic impairment [*see Dosage and Administration (2.4) and Use in Specific Populations (8.6)*].

Patients with Renal Impairment

The pharmacokinetics of abiraterone were examined in patients with end-stage renal disease (ESRD) on a stable hemodialysis schedule (N=8) and in matched control subjects with normal renal function (N=8). In the ESRD cohort of the trial, a single 1,000 mg ZYTIGA dose was given under fasting conditions 1 hour after dialysis, and samples for pharmacokinetic analysis

were collected up to 96 hours post dose. Systemic exposure to abiraterone after a single oral 1,000 mg dose did not increase in subjects with end-stage renal disease on dialysis, compared to subjects with normal renal function [see *Use in Specific Populations* (8.7)].

Drug Interactions

In vitro studies with human hepatic microsomes showed that abiraterone has the potential to inhibit CYP1A2, CYP2D6, CYP2C8 and to a lesser extent CYP2C9, CYP2C19 and CYP3A4/5.

In an *in vivo* drug-drug interaction trial, the C_{max} and AUC of dextromethorphan (CYP2D6 substrate) were increased 2.8- and 2.9-fold, respectively when dextromethorphan 30 mg was given with abiraterone acetate 1,000 mg daily (plus prednisone 5 mg twice daily). The AUC for dextromethorphan, the active metabolite of dextromethorphan, increased approximately 1.3 fold [see *Drug Interactions* (7.2)].

In a clinical study to determine the effects of abiraterone acetate 1,000 mg daily (plus prednisone 5 mg twice daily) on a single 100 mg dose of the CYP1A2 substrate theophylline, no increase in systemic exposure of theophylline was observed.

Abiraterone is a substrate of CYP3A4, *in vitro*. In a clinical pharmacokinetic interaction study of healthy subjects pretreated with a strong CYP3A4 inducer (rifampin, 600 mg daily for 6 days) followed by a single dose of abiraterone acetate 1,000 mg, the mean plasma AUC_{∞} of abiraterone was decreased by 55% [see *Drug Interactions* (7.1)].

In a separate clinical pharmacokinetic interaction study of healthy subjects, co-administration of ketoconazole, a strong inhibitor of CYP3A4, had no clinically meaningful effect on the pharmacokinetics of abiraterone [see *Drug Interactions* (7.1)].

In a CYP2C8 drug-drug interaction trial in healthy subjects, the AUC of pioglitazone was increased by 46% when pioglitazone was given together with a single dose of 1,000 mg abiraterone acetate [see *Drug Interactions* (7.2)].

In vitro, abiraterone and its major metabolites were shown to inhibit the hepatic uptake transporter OATP1B1. There are no clinical data available to confirm transporter based interaction.

13 NONCLINICAL TOXICOLOGY

13.1 Carcinogenesis, Mutagenesis, and Impairment of Fertility

A two-year carcinogenicity study was conducted in rats at oral abiraterone acetate doses of 5, 15, and 50 mg/kg/day for males and 15, 50, and 150 mg/kg/day for females. Abiraterone acetate increased the combined incidence of interstitial cell adenomas and carcinomas in the testes at all

dose levels tested. This finding is considered to be related to the pharmacological activity of abiraterone. Rats are regarded as more sensitive than humans to developing interstitial cell tumors in the testes. Abiraterone acetate was not carcinogenic in female rats at exposure levels up to 0.8 times the human clinical exposure based on AUC. Abiraterone acetate was not carcinogenic in a 6-month study in the transgenic (Tg.rasH2) mouse.

Abiraterone acetate and abiraterone was not mutagenic in an *in vitro* microbial mutagenesis (Ames) assay or clastogenic in an *in vitro* cytogenetic assay using primary human lymphocytes or an *in vivo* rat micronucleus assay.

In repeat-dose toxicity studies in male rats (13- and 26-weeks) and monkeys (39-weeks), atrophy, aspermia/hypospermia, and hyperplasia in the reproductive system were observed at ≥ 50 mg/kg/day in rats and ≥ 250 mg/kg/day in monkeys and were consistent with the antiandrogenic pharmacological activity of abiraterone. These effects were observed in rats at systemic exposures similar to humans and in monkeys at exposures approximately 0.6 times the AUC in humans.

In a fertility study in male rats, reduced organ weights of the reproductive system, sperm counts, sperm motility, altered sperm morphology and decreased fertility were observed in animals dosed for 4 weeks at ≥ 30 mg/kg/day orally. Mating of untreated females with males that received 30 mg/kg/day oral abiraterone acetate resulted in a reduced number of corpora lutea, implantations and live embryos and an increased incidence of pre-implantation loss. Effects on male rats were reversible after 16 weeks from the last abiraterone acetate administration.

In a fertility study in female rats, animals dosed orally for 2 weeks until day 7 of pregnancy at ≥ 30 mg/kg/day had an increased incidence of irregular or extended estrous cycles and pre-implantation loss (300 mg/kg/day). There were no differences in mating, fertility, and litter parameters in female rats that received abiraterone acetate. Effects on female rats were reversible after 4 weeks from the last abiraterone acetate administration.

The dose of 30 mg/kg/day in rats is approximately 0.3 times the recommended dose of 1,000 mg/day based on body surface area.

In 13- and 26-week studies in rats and 13- and 39-week studies in monkeys, a reduction in circulating testosterone levels occurred with abiraterone acetate at approximately one half the human clinical exposure based on AUC. As a result, decreases in organ weights and toxicities were observed in the male and female reproductive system, adrenal glands, liver, pituitary (rats only), and male mammary glands. The changes in the reproductive organs are consistent with the antiandrogenic pharmacological activity of abiraterone acetate.

13.2 Animal Toxicology and/or Pharmacology

A dose-dependent increase in cataracts was observed in rats after daily oral abiraterone acetate administration for 26 weeks starting at ≥ 50 mg/kg/day (similar to the human clinical exposure based on AUC). In a 39-week monkey study with daily oral abiraterone acetate administration, no cataracts were observed at higher doses (2 times greater than the clinical exposure based on AUC).

14 CLINICAL STUDIES

The efficacy and safety of ZYTIGA with prednisone was established in three randomized placebo-controlled international clinical studies. All patients in these studies received a GnRH analog or had prior bilateral orchiectomy. Patients with prior ketoconazole treatment for prostate cancer and a history of adrenal gland or pituitary disorders were excluded from these trials. Concurrent use of spironolactone was not allowed during the study period.

COU-AA-301: Patients with metastatic CRPC who had received prior docetaxel chemotherapy

In COU-AA-301 (NCT00638690), a total of 1195 patients were randomized 2:1 to receive either ZYTIGA orally at a dose of 1,000 mg once daily in combination with prednisone 5 mg orally twice daily (N=797) or placebo once daily plus prednisone 5 mg orally twice daily (N=398). Patients randomized to either arm were to continue treatment until disease progression (defined as a 25% increase in PSA over the patient's baseline/nadir together with protocol-defined radiographic progression and symptomatic or clinical progression), initiation of new treatment, unacceptable toxicity or withdrawal.

The following patient demographics and baseline disease characteristics were balanced between the treatment arms. The median age was 69 years (range 39-95) and the racial distribution was 93% Caucasian, 3.6% Black, 1.7% Asian, and 1.6% Other. Eighty-nine percent of patients enrolled had an ECOG performance status score of 0-1 and 45% had a Brief Pain Inventory-Short Form score of ≥ 4 (patient's reported worst pain over the previous 24 hours). Ninety percent of patients had metastases in bone and 30% had visceral involvement. Seventy percent of patients had radiographic evidence of disease progression and 30% had PSA-only progression. Seventy percent of patients had previously received one cytotoxic chemotherapy regimen and 30% received two regimens.

The protocol pre-specified interim analysis was conducted after 552 deaths and showed a statistically significant improvement in overall survival (OS) in patients treated with ZYTIGA with prednisone compared to patients in the placebo with prednisone arm (Table 9 and Figure 1). An updated survival analysis was conducted when 775 deaths (97% of the planned number of

deaths for final analysis) were observed. Results from this analysis were consistent with those from the interim analysis (Table 7).

Table 7: Overall Survival of Patients Treated with Either ZYTIGA or Placebo in Combination with Prednisone in COU-AA-301 (Intent-to-Treat Analysis)

	ZYTIGA with Prednisone (N=797)	Placebo with Prednisone (N=398)
Primary Survival Analysis		
Deaths (%)	333 (42%)	219 (55%)
Median survival (months) (95% CI)	14.8 (14.1, 15.4)	10.9 (10.2, 12.0)
p-value ¹	<0.0001	
Hazard ratio (95% CI) ²	0.646 (0.543, 0.768)	
Updated Survival Analysis		
Deaths (%)	501 (63%)	274 (69%)
Median survival (months) (95% CI)	15.8 (14.8, 17.0)	11.2 (10.4, 13.1)
Hazard ratio (95% CI) ²	0.740 (0.638, 0.859)	

¹ p-value is derived from a log-rank test stratified by ECOG performance status score (0-1 vs. 2), pain score (absent vs. present), number of prior chemotherapy regimens (1 vs. 2), and type of disease progression (PSA only vs. radiographic).

² Hazard Ratio is derived from a stratified proportional hazards model. Hazard ratio <1 favors ZYTIGA with prednisone.

Figure 1: Kaplan-Meier Overall Survival Curves in COU-AA-301 (Intent-to-Treat Analysis)

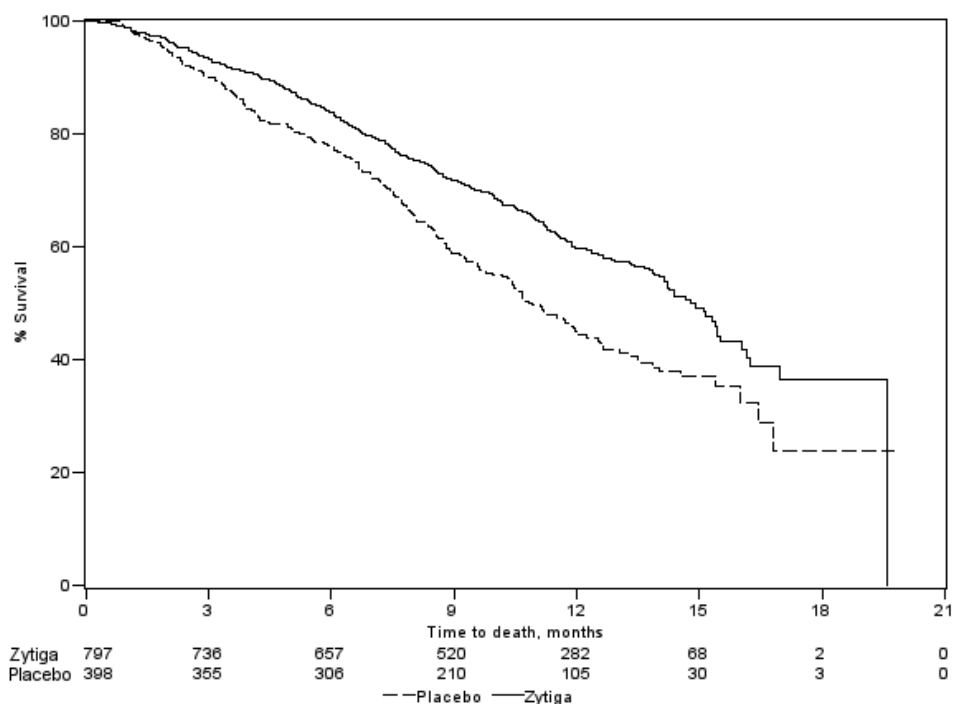

COU-AA-302: Patients with metastatic CRPC who had not received prior cytotoxic chemotherapy

In COU-AA-302 (NCT00887198), 1088 patients were randomized 1:1 to receive either ZYTIGA orally at a dose of 1,000 mg once daily (N=546) or Placebo orally once daily (N=542). Both arms were given concomitant prednisone 5 mg twice daily. Patients continued treatment until radiographic or clinical (cytotoxic chemotherapy, radiation or surgical treatment for cancer, pain requiring chronic opioids, or ECOG performance status decline to 3 or more) disease progression, unacceptable toxicity or withdrawal. Patients with moderate or severe pain, opiate use for cancer pain, or visceral organ metastases were excluded.

Patient demographics were balanced between the treatment arms. The median age was 70 years. The racial distribution of patients treated with ZYTIGA was 95% Caucasian, 2.8% Black, 0.7% Asian and 1.1% Other. The ECOG performance status was 0 for 76% of patients, and 1 for 24% of patients. Co-primary efficacy endpoints were overall survival and radiographic progression-free survival (rPFS). Baseline pain assessment was 0-1 (asymptomatic) in 66% of patients and 2-3 (mildly symptomatic) in 26% of patients as defined by the Brief Pain Inventory-Short Form (worst pain over the last 24 hours).

Radiographic progression-free survival was assessed with the use of sequential imaging studies and was defined by bone scan identification of 2 or more new bone lesions with confirmation (Prostate Cancer Working Group 2 criteria) and/or modified Response Evaluation Criteria In Solid Tumors (RECIST) criteria for progression of soft tissue lesions. Analysis of rPFS utilized centrally-reviewed radiographic assessment of progression.

The planned final analysis for OS, conducted after 741 deaths (median follow up of 49 months) demonstrated a statistically significant OS improvement in patients treated with ZYTIGA with prednisone compared to those treated with placebo with prednisone (Table 8 and Figure 2). Sixty-five percent of patients on the ZYTIGA arm and 78% of patients on the placebo arm used subsequent therapies that may prolong OS in metastatic CRPC. ZYTIGA was used as a subsequent therapy in 13% of patients on the ZYTIGA arm and 44% of patients on the placebo arm.

Table 8: Overall Survival of Patients Treated with Either ZYTIGA or Placebo in Combination with Prednisone in COU-AA-302 (Intent-to-Treat Analysis)

	ZYTIGA with Prednisone (N=546)	Placebo with Prednisone (N=542)
Overall Survival		
Deaths	354 (65%)	387 (71%)
Median survival (months) (95% CI)	34.7 (32.7, 36.8)	30.3 (28.7, 33.3)
p-value ¹	0.0033	
Hazard ratio ² (95% CI)	0.81 (0.70, 0.93)	

¹ p-value is derived from a log-rank test stratified by ECOG performance status score (0 vs. 1).

² Hazard Ratio is derived from a stratified proportional hazards model. Hazard ratio <1 favors ZYTIGA with prednisone.

Figure 2: Kaplan Meier Overall Survival Curves in COU-AA-302

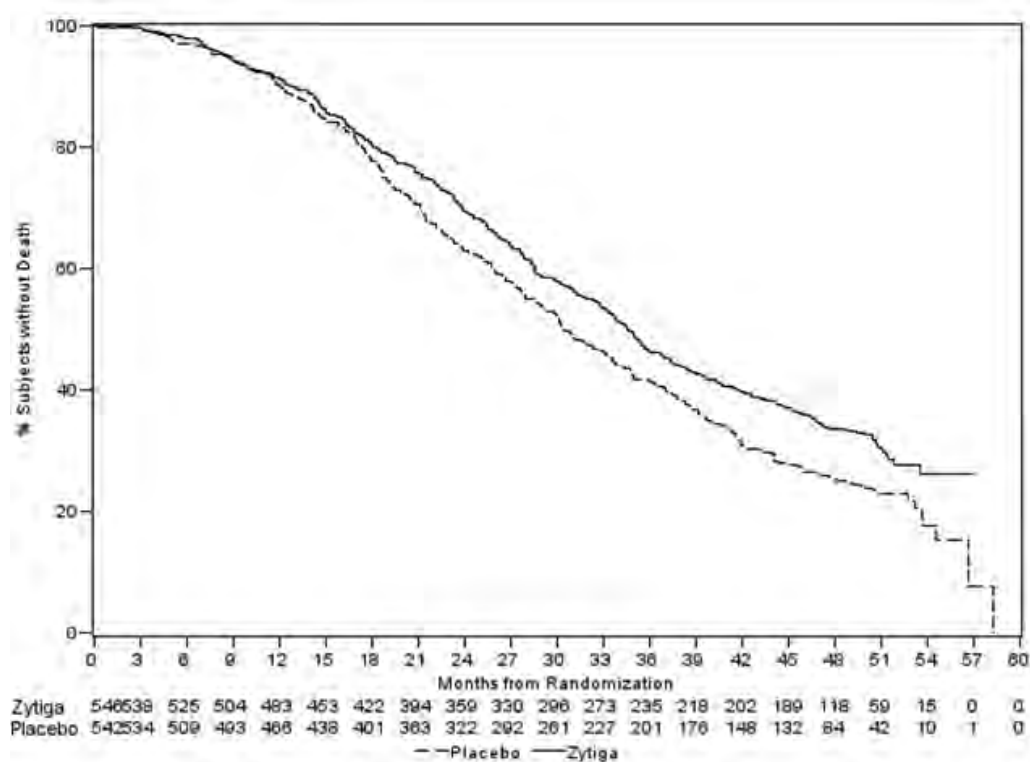

At the pre-specified rPFS analysis, 150 (28%) patients treated with ZYTIGA with prednisone and 251 (46%) patients treated with placebo with prednisone had radiographic progression. A significant difference in rPFS between treatment groups was observed (Table 9 and Figure 3).

Table 9: Radiographic Progression-free Survival of Patients Treated with Either ZYTIGA or Placebo in Combination with Prednisone in COU-AA-302 (Intent-to-Treat Analysis)

	ZYTIGA with Prednisone (N=546)	Placebo with Prednisone (N=542)
Radiographic Progression-free Survival		
Progression or death	150 (28%)	251 (46%)
Median rPFS (months)	NR	8.28
(95% CI)	(11.66, NR)	(8.12, 8.54)
p-value ¹		<0.0001
Hazard ratio ² (95% CI)		0.425 (0.347, 0.522)

NR=Not reached.

¹ p-value is derived from a log-rank test stratified by ECOG performance status score (0 vs. 1).

² Hazard Ratio is derived from a stratified proportional hazards model. Hazard ratio <1 favors ZYTIGA with prednisone.

Figure 3: Kaplan Meier Curves of Radiographic Progression-free Survival in COU-AA-302 (Intent-to-Treat Analysis)

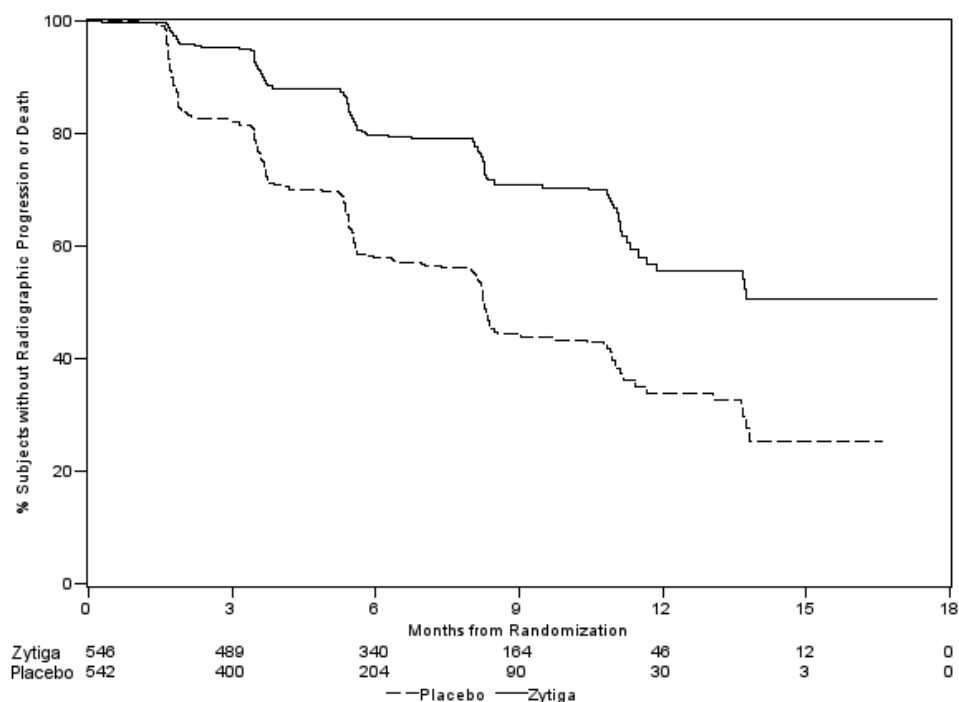

The primary efficacy analyses are supported by the following prospectively defined endpoints. The median time to initiation of cytotoxic chemotherapy was 25.2 months for patients in the ZYTIGA arm and 16.8 months for patients in the placebo arm (HR=0.580; 95% CI: [0.487, 0.691], p < 0.0001).

The median time to opiate use for prostate cancer pain was not reached for patients receiving ZYTIGA and was 23.7 months for patients receiving placebo (HR=0.686; 95% CI: [0.566, 0.833], p=0.0001). The time to opiate use result was supported by a delay in patient reported pain progression favoring the ZYTIGA arm.

LATITUDE: Patients with metastatic high-risk CSPC

In LATITUDE (NCT01715285), 1199 patients with metastatic high-risk CSPC were randomized 1:1 to receive either ZYTIGA orally at a dose of 1,000 mg once daily with prednisone 5 mg once daily (N=597) or placebos orally once daily (N=602). High-risk disease was defined as having at least two of three risk factors at baseline: a total Gleason score of ≥ 8 , presence of ≥ 3 lesions on bone scan, and evidence of measurable visceral metastases. Patients with significant cardiac, adrenal, or hepatic dysfunction were excluded. Patients continued treatment until radiographic or clinical disease progression, unacceptable toxicity, withdrawal or death. Clinical progression was defined as the need for cytotoxic chemotherapy, radiation or surgical treatment for cancer, pain requiring chronic opioids, or ECOG performance status decline to ≥ 3 .

Patient demographics were balanced between the treatment arms. The median age was 67 years among all randomized subjects. The racial distribution of patients treated with ZYTIGA was 69% Caucasian, 2.5% Black, 21% Asian, and 8.1% Other. The ECOG performance status was 0 for 55%, 1 for 42%, and 2 for 3.5% of patients. Baseline pain assessment was 0-1 (asymptomatic) in 50% of patients, 2-3 (mildly symptomatic) in 23% of patients, and ≥ 4 in 28% of patients as defined by the Brief Pain Inventory-Short Form (worst pain over the last 24 hours).

A major efficacy outcome was overall survival. The pre-specified interim analysis after 406 deaths showed a statistically significant improvement in OS in patients on ZYTIGA with prednisone compared to those on placebos. Twenty-one percent of patients on the ZYTIGA arm and 41% of patients on the placebos arm received subsequent therapies that may prolong OS in metastatic CRPC. An updated survival analysis was conducted when 618 deaths were observed. The median follow-up time was 52 months. Results from this analysis were consistent with those from the pre-specified interim analysis (Table 10 and Figure 4). At the updated analysis, 29% of patients on the ZYTIGA arm and 45% of patients on the placebos arm received subsequent therapies that may prolong OS in metastatic CRPC.

Table 10: Overall Survival of Patients Treated with Either ZYTIGA or Placebos in LATITUDE (Intent-to-Treat Analysis)

	ZYTIGA with Prednisone (N=597)	Placebos (N=602)
Overall Survival¹		
Deaths (%)	169 (28%)	237 (39%)
Median survival (months) (95% CI)	NE (NE, NE)	34.7 (33.1, NE)
p-value ²	<0.0001	
Hazard ratio (95% CI) ³	0.62 (0.51, 0.76)	
Updated Overall Survival		
Deaths (%)	275 (46%)	343 (57%)
Median survival (months) (95% CI)	53.3 (48.2, NE)	36.5 (33.5, 40.0)
Hazard ratio (95% CI) ³	0.66 (0.56, 0.78)	

NE=Not estimable

¹ This is based on the pre-specified interim analysis

² p value is from log-rank test stratified by ECOG PS score (0/1 or 2) and visceral (absent or present).

³ Hazard Ratio is derived from a stratified proportional hazards model. Hazard ratio <1 favors ZYTIGA with prednisone.

Figure 4: Kaplan-Meier Plot of Overall Survival; Intent-to-treat Population in LATITUDE Updated Analysis

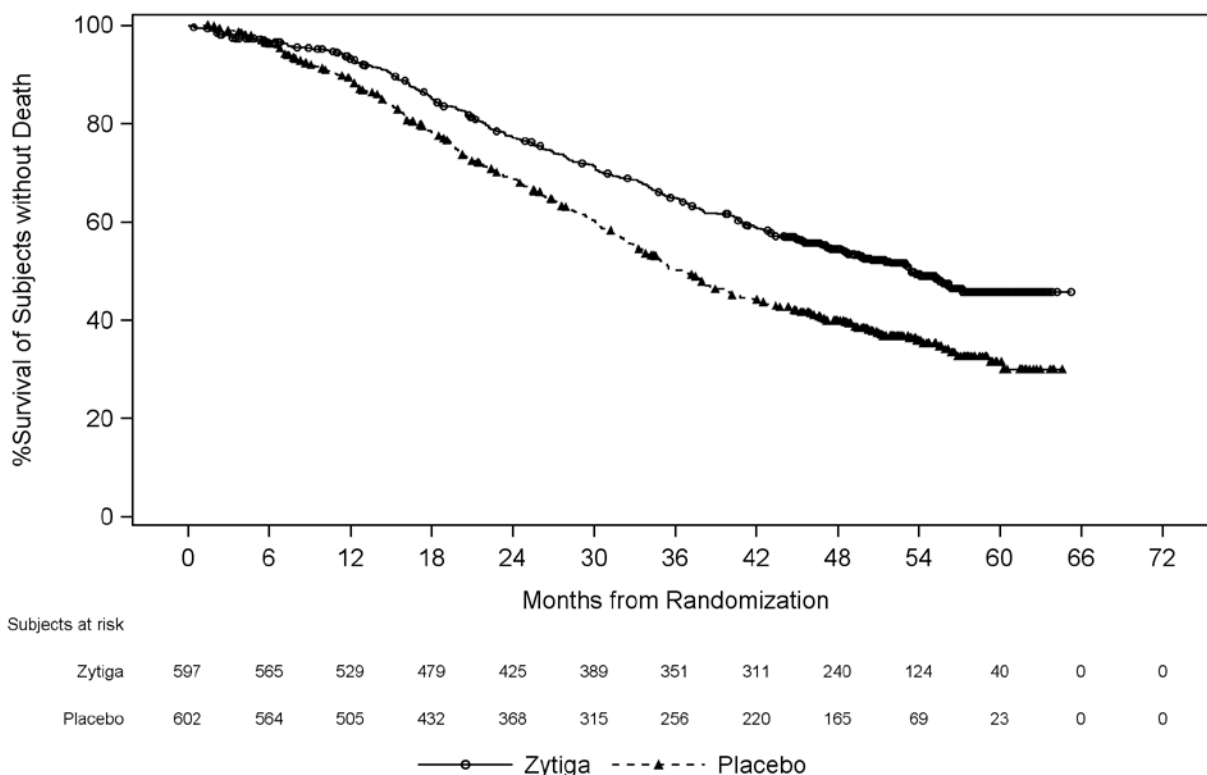

The major efficacy outcome was supported by a statistically significant delay in time to initiation of chemotherapy for patients in the ZYTIGA arm compared to those in the

placebos arm. The median time to initiation of chemotherapy was not reached for patients on ZYTIGA with prednisone and was 38.9 months for patients on placebos (HR = 0.44; 95% CI: [0.35, 0.56], $p < 0.0001$).

16 HOW SUPPLIED/STORAGE AND HANDLING

ZYTIGA[®] (abiraterone acetate) Tablets are available in the strengths and packages listed below:

- **ZYTIGA[®] 500 mg film-coated Tablets**

Purple, oval-shaped tablets debossed with “AA” one side and “500” on the other side.

NDC 57894-195-06 60 tablets available in high-density polyethylene bottles

- **ZYTIGA[®] 250 mg uncoated Tablets**

White to off-white, oval-shaped tablets debossed with “AA250” on one side.

NDC 57894-150-12 120 tablets available in high-density polyethylene bottles

Storage and Handling

Store at 20°C to 25°C (68°F to 77°F); excursions permitted in the range from 15°C to 30°C (59°F to 86°F) [*see USP Controlled Room Temperature*].

Keep out of reach of children.

Based on its mechanism of action, ZYTIGA may harm a developing fetus. Women who are pregnant or women who may be pregnant should not handle ZYTIGA 250 mg uncoated tablets or other ZYTIGA tablets if broken, crushed, or damaged without protection, e.g., gloves [*see Use in Specific Populations (8.1)*].

17 PATIENT COUNSELING INFORMATION

Advise the patient to read the FDA-approved patient labeling (Patient Information)

Hypokalemia, Fluid Retention, and Cardiovascular Adverse Reactions

- Inform patients that ZYTIGA is associated with hypertension, hypokalemia, and peripheral edema that may lead to QT prolongation and Torsades de Pointes in patients who develop hypokalemia while taking ZYTIGA. Advise patients that their blood pressure, serum potassium and signs and symptoms of fluid retention will be monitored clinically at least monthly. Advise patients to adhere to corticosteroids and to report symptoms of hypertension, hypokalemia, or edema to their healthcare provider [*see Warnings and Precautions (5.1)*].

Adrenocortical Insufficiency

- Inform patients that ZYTIGA with prednisone is associated with adrenal insufficiency. Advise patients to report symptoms of adrenocortical insufficiency to their healthcare provider [*see Warnings and Precautions (5.2)*].

Hepatotoxicity

- Inform patients that ZYTIGA is associated with severe hepatotoxicity. Inform patients that their liver function will be monitored using blood tests. Advise patients to immediately report symptoms of hepatotoxicity to their healthcare provider [*see Warnings and Precautions (5.3)*].

Hypoglycemia

- Inform patients that severe hypoglycemia has been reported when ZYTIGA was administered to patients with pre-existing diabetes who were receiving medications containing thiazolidinediones (including pioglitazone) or repaglinide – antidiabetic drugs. Advise patients with diabetes to monitor glucose levels during and after treatment with ZYTIGA [*see Warnings and Precautions (5.6) and Drug Interactions (7.2)*].

Use in Combination with Radium Ra 223 Dichloride

- Advise patients that radium Ra 223 dichloride showed an increase in mortality and an increased rate of fracture when used in combination with ZYTIGA plus prednisone/prednisolone. Inform patients to speak with their healthcare provider about any other medications or treatment they are currently taking for prostate cancer [*see Warnings and Precautions (5.4)*].

Dosing and Administration

- Inform patients that ZYTIGA is taken once daily with prednisone (once or twice daily according to their healthcare provider's instructions) and to not interrupt or stop either of these medications without consulting their healthcare provider.
- Inform patients receiving GnRH therapy that they need to maintain this treatment during the course of treatment with ZYTIGA.
- Instruct patients to take ZYTIGA on an empty stomach, at least one hour before or at least two hours after a meal. ZYTIGA taken with food causes increased exposure and may result in adverse reactions. Instruct patients to swallow tablets whole with water and not to crush or chew the tablets [*see Dosage and Administration (2.3)*].
- Inform patients that if they miss a dose of ZYTIGA or prednisone, they should take their normal dose the following day. If more than one daily dose is skipped, inform patients to contact their healthcare provider [*see Dosage and Administration (2.3)*].

Embryo-Fetal Toxicity

- Inform patients that ZYTIGA may harm a developing fetus and can cause loss of pregnancy.
- Advise males with female partners of reproductive potential to use effective contraception during treatment and for 3 weeks after the final dose of ZYTIGA [*see Use in Specific Populations (8.1)*].
- Advise females who are pregnant or women who may be pregnant not to handle ZYTIGA 250 mg uncoated tablets or other ZYTIGA tablets if broken, crushed, or damaged without protection, e.g., gloves [*see Use in Specific Populations (8.1)* and *How Supplied/Storage and Handling (16)*].

Infertility

- Advise male patients that ZYTIGA may impair fertility [*see Use in Specific Populations (8.3)*].

Product of Belgium

500 mg Tablets

Manufactured by:

Patheon France S.A.S.

Bourgoin Jallieu, France

250 mg Tablets

Manufactured by:

Patheon Inc.

Mississauga, Canada

Manufactured for:

Janssen Biotech, Inc.

Horsham, PA 19044

© 2011, 2017 Janssen Pharmaceutical Companies

Revised: 10/2020

PATIENT INFORMATION
ZYTIGA® (Zye-tee-ga)
(abiraterone acetate)
tablets

What is ZYTIGA?

ZYTIGA is a prescription medicine that is used along with prednisone. ZYTIGA is used to treat men with prostate cancer that has spread to other parts of the body.

It is not known if ZYTIGA is safe and effective in females or children.

Before taking ZYTIGA, tell your healthcare provider about all of your medical conditions, including if you:

- have heart problems
- have liver problems
- have diabetes
- have a history of adrenal problems
- have a history of pituitary problems
- are receiving any other treatment for prostate cancer
- are pregnant or plan to become pregnant. ZYTIGA can cause harm to your unborn baby and loss of pregnancy (miscarriage). Females who are or may become pregnant should not handle ZYTIGA uncoated tablets or other ZYTIGA tablets if broken, crushed, or damaged without protection, such as gloves.
- have a partner who is pregnant or may become pregnant.
 - Males who have female partners who are able to become pregnant should use effective birth control (contraception) during treatment with ZYTIGA and for 3 weeks after the last dose of ZYTIGA.
- are breastfeeding or plan to breastfeed. It is not known if ZYTIGA passes into your breastmilk.

Tell your healthcare provider about all the medicines you take or treatments you receive, including prescription and over-the-counter medicines, vitamins, and herbal supplements. ZYTIGA can interact with many other medicines.

You should not start or stop any medicine before you talk with the healthcare provider that prescribed ZYTIGA.

Know the medicines you take. Keep a list of them with you to show to your healthcare provider and pharmacist when you get a new medicine.

How should I take ZYTIGA?

- Take ZYTIGA and prednisone exactly as your healthcare provider tells you.
- Take your prescribed dose of ZYTIGA 1 time a day.
- Your healthcare provider may change your dose if needed.
- **Do not change or stop taking your prescribed dose of ZYTIGA or prednisone without talking with your healthcare provider first.**
- Take ZYTIGA on an empty stomach, at least one hour before or at least two hours after a meal. **Do not take ZYTIGA with food.** Taking ZYTIGA with food may cause more of the medicine to be absorbed by the body than is needed and this may cause side effects.
- Swallow ZYTIGA tablets whole. Do not crush or chew tablets.
- Take ZYTIGA tablets with water.
- If you miss a dose of ZYTIGA or prednisone, take your prescribed dose the following day. If you miss more than 1 dose, tell your healthcare provider right away.
- Your healthcare provider will do blood tests to check for side effects.

What are the possible side effects of ZYTIGA?

ZYTIGA may cause serious side effects including:

- **High blood pressure (hypertension), low blood potassium levels (hypokalemia), fluid retention (edema), and irregular heartbeats can happen during treatment with ZYTIGA.** This can be life threatening. To decrease the chance of this happening, you must take prednisone with ZYTIGA exactly as your healthcare provider tells you. Your healthcare provider will check your blood pressure, do blood tests to check your potassium levels, and check for any signs and symptoms of fluid retention every month during treatment with ZYTIGA.

Tell your healthcare provider if you get any of the following symptoms:

- dizziness
 - fast or irregular heartbeats
 - feel faint or lightheaded
 - headache
 - confusion
 - muscle weakness
 - pain in your legs
 - swelling in your legs or feet
- **Adrenal problems** may happen if you stop taking prednisone, get an infection, or are under stress.
 - **Severe liver problems.** You may develop changes in liver function blood test. Your healthcare provider will do blood tests to check your liver before treatment with ZYTIGA and during treatment with ZYTIGA. Liver failure may occur, which can lead to death. Tell your healthcare provider right away if you notice any of the following changes:
 - yellowing of the skin or eyes
 - darkening of the urine
 - severe nausea or vomiting
 - **Increased risk of bone fracture and death** when ZYTIGA and prednisone or prednisolone, is used in combination with a type of radiation called radium Ra 223 dichloride. Tell your healthcare provider about any other treatments you are taking for prostate cancer.
 - **Severe low blood sugar (hypoglycemia).** Severe low blood sugar with ZYTIGA can happen in people who have diabetes and take certain antidiabetic medicines. You and/or your healthcare provider should check your blood sugar levels regularly during treatment with ZYTIGA and after you stop treatment. Your healthcare provider may also need to change the dose of your antidiabetic medicines. Signs and symptoms of low blood sugar may include:
 - headache
 - drowsiness
 - weakness
 - dizziness
 - confusion
 - irritability
 - hunger
 - fast heart beat
 - sweating
 - feeling jittery

The most common side effects of ZYTIGA include:

- feeling very tired
- joint pain
- high blood pressure
- nausea
- swelling in your legs or feet
- low blood potassium levels
- hot flushes
- diarrhea
- vomiting
- infected nose, sinuses, or throat (cold)
- cough
- headache
- low red blood cells (anemia)
- high blood cholesterol and triglycerides
- high blood sugar levels
- certain other abnormal blood tests

ZYTIGA may cause fertility problems in males, which may affect the ability to father children. Talk to your healthcare provider if you have concerns about fertility.

These are not all the possible side effects of ZYTIGA. Call your healthcare provider for medical advice about side effects. You may report side effects to FDA at 1-800-FDA-1088.

How should I store ZYTIGA?

- Store ZYTIGA at room temperature between 68°F to 77°F (20°C to 25°C).

Keep ZYTIGA and all medicines out of the reach of children.

General information about the safe and effective use of ZYTIGA.

Medicines are sometimes prescribed for purposes other than those listed in a Patient Information leaflet. Do not use ZYTIGA for a condition for which it was not prescribed. Do not give ZYTIGA to other people, even if they have the same symptoms that you have. It may harm them.

You can ask your healthcare provider or pharmacist for information about ZYTIGA that is written for health professionals.

What are the ingredients of ZYTIGA?

Active ingredient: abiraterone acetate

Inactive ingredients:

500 mg film-coated tablets: colloidal silicon dioxide, croscarmellose sodium, hypromellose, lactose monohydrate, magnesium stearate, silicified microcrystalline cellulose, and sodium lauryl sulfate. The film-coating contains iron oxide black, iron oxide red, polyethylene glycol, polyvinyl alcohol, talc, and titanium dioxide.

250 mg uncoated tablets: colloidal silicon dioxide, croscarmellose sodium, lactose monohydrate, magnesium stearate, microcrystalline cellulose, povidone, and sodium lauryl sulfate.

Product of Belgium

500 mg Tablets

Manufactured by: Patheon France S.A.S., Bourgoin Jallieu, France

250 mg Tablets

Manufactured by: Patheon Inc., Mississauga, Canada

Manufactured for: Janssen Biotech, Inc., Horsham, PA 19044

For more information, call Janssen Biotech, Inc. at 1-800-526-7736 (1-800-JANSSEN) or go to www.Zytiga.com.

© 2011, 2017 Janssen Pharmaceutical Companies

This Patient Information has been approved by the U.S. Food and Drug Administration.

Revised: Oct 2020